

AD-A175 265

IMPROVING THE PERFORMANCE OF A MILLIMETER-WAVE SCALAR
NETWORK ANALYZER(U) NAVAL POSTGRADUATE SCHOOL MONTEREY
CA D E FALKNER SEP 86

1/2

UNCLASSIFIED

F/G 14/2

NL

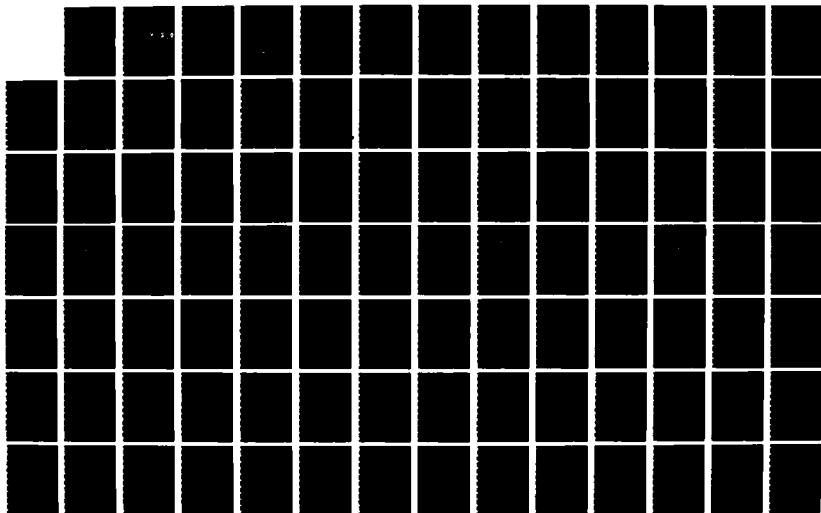

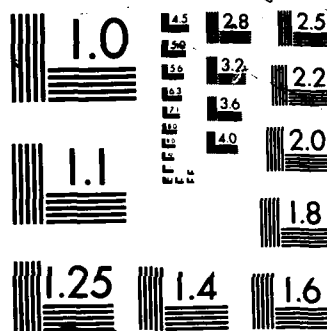

XEROCOPY RESOLUTION TEST CHART

AD-A175 265

(2)

NAVAL POSTGRADUATE SCHOOL

Monterey, California



DTIC
ELECTE
DEC 24 1986
S D

THESIS

DTIC FILE COPY

IMPROVING THE PERFORMANCE OF A
MILLIMETER-WAVE SCALAR NETWORK ANALYZER

by

David E. Falkner

September 1986

Thesis Advisor:

Jeffrey B. Knorr

Approved for public release; distribution is unlimited.

86 12 22 058

ADA 175265

SECURITY CLASSIFICATION OF THIS PAGE

REPORT DOCUMENTATION PAGE

1a REPORT SECURITY CLASSIFICATION UNCLASSIFIED		1b. RESTRICTIVE MARKINGS	
2a SECURITY CLASSIFICATION AUTHORITY		3 DISTRIBUTION / AVAILABILITY OF REPORT Approved for public release; distribution is unlimited	
2b. DECLASSIFICATION / DOWNGRADING SCHEDULE			
4 PERFORMING ORGANIZATION REPORT NUMBER(S)		5. MONITORING ORGANIZATION REPORT NUMBER(S)	
6a. NAME OF PERFORMING ORGANIZATION Naval Postgraduate School	6b OFFICE SYMBOL (If applicable) 62	7a. NAME OF MONITORING ORGANIZATION Naval Postgraduate School	
6c. ADDRESS (City, State, and ZIP Code) Monterey, California 93943-5000		7b. ADDRESS (City, State, and ZIP Code) Monterey, California 93943-5000	
8a NAME OF FUNDING / SPONSORING ORGANIZATION	8b. OFFICE SYMBOL (If applicable)	9. PROCUREMENT INSTRUMENT IDENTIFICATION NUMBER	
8c ADDRESS (City, State, and ZIP Code)		10 SOURCE OF FUNDING NUMBERS	
		PROGRAM ELEMENT NO	PROJECT NO
		TASK NO	WORK UNIT ACCESSION NO
11 TITLE (Include Security Classification) IMPROVING THE PERFORMANCE OF A MILLIMETER-WAVE SCALAR NETWORK ANALYZER			
12 PERSONAL AUTHOR(S) Falkner, David E.			
13a TYPE OF REPORT Master's Thesis	13b TIME COVERED FROM _____ TO _____	14 DATE OF REPORT (Year, Month, Day) 1986 September	15 PAGE COUNT 158
16 SUPPLEMENTARY NOTATION			
17 COSATI CODES		18 SUBJECT TERMS (Continue on reverse if necessary and identify by block number)	
FIELD	GROUP	SUB-GROUP	
		Measurement Techniques, Millimeter-Wave, Scalar Network Analyzer, Automated Scalar Network Analyzer	
19 ABSTRACT (Continue on reverse if necessary and identify by block number)			
<p>This thesis describes improvements made to an existing Millimeter-Wave Scalar Network Analyzer. The system is automated and can be used to make return and/or insertion loss measurements from 60 to 90 GHz. Measurement data can be printed or plotted on a CRT or thermal printer. Additionally, a high resolution plot with up to 4 colors can be made on an external plotter.</p> <p>Other topics which are discussed include software modification, improved performance in measurement taking, dynamic range of the system, component influence on measurements and comparison of device measurements with those obtained from previous theses and manufacturer specifications.</p>			
20 DISTRIBUTION / AVAILABILITY OF ABSTRACT <input checked="" type="checkbox"/> UNCLASSIFIED/UNLIMITED <input type="checkbox"/> SAME AS RPT <input type="checkbox"/> DTIC USERS		21. ABSTRACT SECURITY CLASSIFICATION UNCLASSIFIED	
22a NAME OF RESPONSIBLE INDIVIDUAL Jeffrey B. Knorr		22b TELEPHONE (Include Area Code) (408) 646-2815	22c OFFICE SYMBOL 62K0

Approved for public release; distribution is unlimited.

Improving the Performance of a
Millimeter-Wave Scalar Network Analyzer

by

David E. Falkner
Lieutenant, United States Navy
B.S., Purdue University, 1980

Submitted in partial fulfillment of the
requirements for the degree of

MASTER OF SCIENCE IN ELECTRICAL ENGINEERING

from the

NAVAL POSTGRADUATE SCHOOL
September 1986

Author:



David E. Falkner

Approved by:



Jeffrey E. Knorr, Thesis Advisor

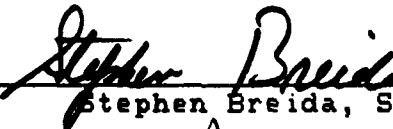

Stephen Breida, Second Reader

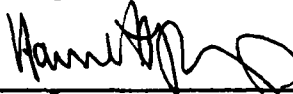

Harriet Rigas, Chairman, Department of
Electrical and Computer Engineering



John N. Dyer
Dean of Science and Engineering

ABSTRACT

This thesis describes improvements made to an existing Millimeter-Wave Scalar Network Analyzer. The system is automated and can be used to make return and/or insertion loss measurements from 60 to 90 GHz. Measurement data can be printed or plotted on a CRT or thermal printer. Additionally, a high resolution plot with up to 4 colors can be made on an external plotter.

Other topics which are discussed include software modification, improved performance in measurement taking, dynamic range of the system, component influence on measurements and comparison of device measurements with those obtained from previous theses and manufacturer specifications.



Accession For	
NTIS CRA&I	<input checked="" type="checkbox"/>
DTIC TAB	<input type="checkbox"/>
Unannounced	<input type="checkbox"/>
Justification	
By	
Distribution/	
Availability Codes	
Dist	Avail and/or Special
A-1	

TABLE OF CONTENTS

I.	INTRODUCTION.....	12
A.	BACKGROUND.....	12
B.	PURPOSE.....	14
C.	RELATED WORK.....	14
	1. Return Loss Measurement Analysis.....	18
	2. Insertion Loss Measurement Analysis.....	23
II.	SYSTEM DESCRIPTION.....	27
A.	HARDWARE.....	27
	1. Computer.....	27
	2. Sweeper Controller.....	29
	3. Millimeter-Wave 60-90 GHz Full Band Plug-In.....	29
	4. Scalar Network Analyzer.....	30
	5. Plotter.....	31
B.	SYSTEM CONNECTION.....	31
C.	SOFTWARE.....	33
III.	RESULTS.....	38
A.	RETURN LOSS MEASUREMENTS.....	38
	1. Calibration.....	39
	a. Minimum Uncertainty Computation Problem.....	44
	2. Return Loss Accuracy.....	46
	3. Dynamic Range.....	47
	a. Diode Detector Comparison.....	47
	4. Comparisons With Previous Theses Results.	56

a.	Fixed Short from 60-70 GHz and 70-80 GHz.....	58
b.	Tunable Load from 70-80 GHz.....	58
c.	Detector Mount from 70-80 GHz.....	58
5.	Comparison With Manufactured Device.....	63
B.	INSERTION LOSS MEASUREMENTS.....	63
1.	Calibration.....	65
2.	Insertion Loss Accuracy.....	65
3.	Dynamic Range.....	77
4.	Comparisons with Previous Theses Results.	77
a.	10 dB Attenuator from 70-80 GHz.....	77
b.	20 dB Attenuator from 70-80 GHz.....	80
c.	30 dB Attenuator from 70-80 GHz.....	80
d.	40 dB Attenuator from 70-80 GHz.....	80
e.	10 dB Directional Coupler from 70-80 GHz.....	80
f.	Through Section from 70-80 GHz.....	80
g.	Baytron Variable Attenuator from 60-90 GHz.....	86
C.	PLOTTER PERFORMANCE.....	86
IV.	CONCLUSIONS AND RECOMMENDATIONS.....	89
A.	CONCLUSIONS.....	89
B.	RECOMMENDATIONS.....	89
1.	Schottky Barrier Diode Detector.....	89
2.	Measurement Accuracy.....	90
3.	Band Switch Jumps.....	90
4.	Maximum Uncertainty Calibration.....	90

5. Plotter Parameters.....	91
APPENDIX A: USER'S GUIDE.....	92
A. SYSTEM CONNECTIONS.....	92
B. SYSTEM START-UP.....	92
C. SYSTEM INITIALIZATION.....	92
D. RETURN LOSS MEASUREMENTS.....	94
E. INSERTION LOSS MEASUREMENTS.....	95
F. OUTPUT.....	96
APPENDIX B: PROGRAM LISTING AND VARIABLES.....	100
A. PROGRAM LISTING.....	100
B. LIST OF VARIABLES.....	100
APPENDIX C: TABULAR DATA OF MEASUREMENTS USING SCHOTTKY BARRIER DIODE DETECTOR.....	119
LIST OF REFERENCES.....	156
INITIAL DISTRIBUTION.....	157

LIST OF TABLES

I.	SPECIFIC REFLECTOMETER COMPONENTS USED FOR THE AUTOMATED MILLIMETER-WAVE SCALAR NETWORK ANALYZER.....	32
II.	PRINTED OUTPUT OF FIXED SHORT RETURN LOSS USING SCHOTTKY DIODE DETECTOR.....	120
III.	PRINTED OUTPUT OF MATCHED LOAD RETURN LOSS USING SCHOTTKY DIODE DETECTOR.....	124
IV.	PRINTED OUTPUT OF RETURN LOSS FOR 5 dB ATTENUATOR WITH SHORTED OUTPUT USING SCHOTTKY DIODE DETECTOR.....	128
V.	PRINTED OUTPUT OF RETURN LOSS FOR 10 dB ATTENUATOR WITH SHORTED OUTPUT USING SCHOTTKY DIODE DETECTOR.....	132
VI.	PRINTED OUTPUT OF RETURN LOSS FOR 15 dB ATTENUATOR WITH SHORTED OUTPUT USING SCHOTTKY DIODE DETECTOR.....	136
VII.	PRINTED OUTPUT OF RETURN LOSS FOR 18 dB ATTENUATOR WITH SHORTED OUTPUT USING SCHOTTKY DIODE DETECTOR.....	140
VIII.	DIODE DETECTOR VOLTAGE LEVELS.....	56
IX.	PRINTED OUTPUT OF INSERTION LOSS FOR 0 dB ATTENUATOR USING SCHOTTKY DIODE DETECTOR.....	144
X.	PRINTED OUTPUT OF INSERTION LOSS FOR 10 dB ATTENUATOR USING SCHOTTKY DIODE DETECTOR.....	146
XI.	PRINTED OUTPUT OF INSERTION LOSS FOR 20 dB ATTENUATOR USING SCHOTTKY DIODE DETECTOR.....	148
XII.	PRINTED OUTPUT OF INSERTION LOSS FOR 30 dB ATTENUATOR USING SCHOTTKY DIODE DETECTOR.....	150
XIII.	PRINTED OUTPUT OF INSERTION LOSS FOR 40 dB ATTENUATOR USING SCHOTTKY DIODE DETECTOR.....	152
XIV.	PRINTED OUTPUT OF INSERTION LOSS FOR 45 dB ATTENUATOR USING SCHOTTKY DIODE DETECTOR.....	154

LIST OF FIGURES

1.	Scattering Parameter Signal Flow Diagram for a Two Port Network.....	16
2.	Basic Diagrams For Return and Insertion Loss Measurements.....	16
3.	Phasor Diagrams for Establishing 0 dB Return-Loss Signal Level In Scalar Network Analyzers.....	19
4.	Diagram of Automated Millimeter-Wave Scalar Network Analyzer System.....	28
5.	Measurement Flow Chart For "MMWSNA" Program.....	37
6.	Fixed Short Return Loss Using Whisker Diode Detector.....	40
7.	Matched Load Return Loss Using Whisker Diode Detector.....	41
8.	Fixed Short Return Loss Using Schottky Diode Detector.....	42
9.	Matched Load Return Loss Using Schottky Diode Detector.....	43
10.	Calibrated Return Loss Setup.....	46
11.	Return Loss for 5 dB Attenuator With Shorted Output Using Whisker Diode Detector.....	48
12.	Return Loss for 10 dB Attenuator With Shorted Output Using Whisker Diode Detector.....	49
13.	Return Loss for 12.5 dB Attenuator With Shorted Output Using Whisker Diode Detector.....	50
14.	Return Loss for 5 dB Attenuator With Shorted Output Using Schottky Diode Detector.....	51
15.	Return Loss for 10 dB Attenuator With Shorted Output Using Schottky Diode Detector.....	52
16.	Return Loss for 15 dB Attenuator With Shorted Output Using Schottky Diode Detector.....	53
17.	Return Loss for 18 dB Attenuator With Shorted Output Using Schottky Diode Detector.....	54

18.	Dynamic Range for Return Loss.....	55
19.	Diode Detector Output Voltage Comparison.....	57
20.	Fixed Short Return Loss Comparison from 60-70 GHz.	59
21.	Fixed Short Return Loss Comparison from 70-80 GHz.	60
22.	Tunable Load Return Loss Comparison from 70-80 GHz.....	61
23.	Detector Mount Return Loss Comparison from 70-80 GHz.....	62
24.	Return Loss for Horn Antenna from 70-80 GHz.....	64
25.	Insertion Loss for 0 dB Attenuator Using Whisker Diode Detector.....	66
26.	Insertion Loss for 10 dB Attenuator Using Whisker Diode Detector.....	67
27.	Insertion Loss for 20 dB Attenuator Using Whisker Diode Detector.....	68
28.	Insertion Loss for 25 dB Attenuator Using Whisker Diode Detector.....	69
29.	Insertion Loss for 0 dB Attenuator Using Schottky Diode Detector.....	71
30.	Insertion Loss for 10 dB Attenuator Using Schottky Diode Detector.....	72
31.	Insertion Loss for 20 dB Attenuator Using Schottky Diode Detector.....	73
32.	Insertion Loss for 30 dB Attenuator Using Schottky Diode Detector.....	74
33.	Insertion Loss for 40 dB Attenuator Using Schottky Diode Detector.....	75
34.	Insertion Loss for 45 dB Attenuator Using Schottky Diode Detector.....	76
35.	Dynamic Range for Insertion Loss.....	78
36.	10 dB Attenuator Insertion Loss Comparison from 70-80 GHz.....	79

37.	20 dB Attenuator Insertion Loss Comparison from 70-80 GHz.....	81
38.	30 dB Attenuator Insertion Loss Comparison from 70-80 GHz.....	82
39.	40 dB Attenuator Insertion Loss Comparison from 70-80 GHz.....	83
40.	Directional Coupler Insertion Loss Comparison from 70-80 GHz.....	84
41.	Through Section Insertion Loss Comparison from 60-90 GHz.....	85
42.	Baytron Variable Attenuator Insertion Loss Comparison at 10 dB from 60-90 GHz.....	87

ACKNOWLEDGEMENT

I would sincerely like to thank my thesis advisor, Professor Jeffrey B. Knorr, for his guidance and assistance throughout this thesis.

I would also like to thank my wife, Kathy, and our children for their patience and support during my tour as a student at the Naval Postgraduate School.

This thesis is dedicated to my mother and father.

I. INTRODUCTION

A. BACKGROUND

In the past few years the popularity of millimeter-wave systems has been steadily increasing. Small physical dimensions, low power requirements and large bandwidths have allowed the advent of millimeter-wave systems in many areas of electronics including communications, computer links, medicine, radar and radio astronomy.

With increased system demand comes the need to test components of millimeter-wave systems quickly and accurately. In the past computer control of a Scalar Network Analyzer was possible through the use of an Analog to Digital (A/D) converter. Such a system was developed at the Naval Postgraduate School in 1982 using the HP-9845B computer, HP-47310A A/D converter, HP-8755 Scalar Network Analyzer, HP-8620C Sweep Controller with the Hughes 47225H Full Band Sweep Plug-in and a Reflectometer Set-up using Hughes and Baytron components. (Ref. 1) This system provided a means for automated millimeter band measurements from 60 to 90 GHz. The analog main frames required extensive computer control to provide computational data and this large amount of peripheral control resulted in slower measurement times than would have been expected with an automated system.

Late model analyzer and sweeper main frames now enable direct computer control of all analyzer and sweeper

functions. Sweep data can also be internally digitized to allow full control and data passing without the need for an A/D converter. This ability to allow main frame control of functions which were originally computer controlled simplifies software commands and speeds up the measurement process. Hughes Aircraft Company now offers such a system utilizing the HP-85 computer, HP-8756 or HP-8757 Scalar Network Analyzer, HP-8350 Sweep Controller with a Hughes Full Band Millimeter-Wave Plug In and a Reflectometer Set-up using Hughes components (Ref. 2:pp. 24-25). The software is customized to the Reflectometer components selected and the desired application.

Improvements in the Naval Postgraduate School

Millimeter-Wave Scalar Network Analyzer system now offer the following features:

1. MENU DRIVEN computer control of system calibration and Device Under Test (DUT) measurements.
2. The ability to perform several DUT measurements of return and/or insertion loss from a single calibration.
3. Control of the number of data points used for the calibration/measurement from a menu choice of seven possibilities ranging from 10 data points to 401 data points.
4. All of the calibration data is taken before the lengthy calculations are started thus minimizing operator interface time.
5. DISPLAY of measurement results either in tabular or graphical form.
6. PRINTER output of measurement results in tabular or graphical form.
7. PLOTTER output using the HP-9872 series high resolution multicolor plotter.

Software modifications have also made insertion loss measurements with the "A" coupler installed faster and easier.

B. PURPOSE

This thesis investigates the performance of an automated Millimeter-Wave Scalar Network Analyzer using the following components:

1. HP-9845B Computer.
2. HP-8350B Mainframe Sweeper with the Hughes Full Band Millimeter-Wave Plug-in.
3. HP-8756 Mainframe Scalar Network Analyzer.
4. Reflectometer Setup using Hughes components.
5. HP-9872 Plotter.

The system performance will be compared with known components with attributes and deficiencies noted. Additionally the measurements obtained will also be compared with measurements obtained in previous theses and with manufacturers component specifications. The systems dynamic range will be determined and compared with the Hughes Automated Millimeter-Wave Scalar Network Analyzer.

C. RELATED WORK

Under the direction of Professor Jeffrey B. Knorr, U. S. Naval Postgraduate School, G. S. Leoussis and E. D. Gatsos developed the NPS Automated Millimeter-Wave Scalar Network Analyzer (Refs. 1,4). Professor Knorr's development of the measurement theory and mathematical models used in the software can be found in Reference 3.

The Millimeter-Wave Scalar Network Analyzer is a waveguide based system. The system must be able to measure the incident and scattered RF power of a device under test (DUT). Performance is given in terms of the scattering parameter amplitudes which can then be used to compute the return loss and/or the insertion loss of the DUT.

In general, scattering parameters can be defined in the form:

$$S_{mn} = \frac{b_m}{a_n} \Big|_{a_i=0} \quad (i \neq n) \quad (1)$$

where S_{mn} is the complex ratio of the variable b_m of a signal (wave) emerging from port m relative to the variable a_n of a signal (wave) incident at port n . The Network Analyzer is designed to measure parameters proportional to $|b_m|$ and $|a_n|$ so that their amplitude ratio can be computed. Since this type of measurement lends itself easily to computer control and computations, typically modern systems are automated. The objective is to use the measurement system to determine the insertion loss, IL, and return loss, RL, of a DUT. For illustrative purposes, with the generic two-port device in Figure 1 placed in the forward direction (Port A driven), the return loss at Port A and the insertion loss from Port A to Port B are related to the scattering coefficients of the DUT by:

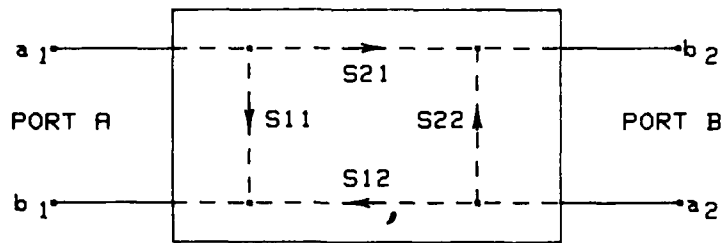

Figure 1. Scattering Parameter Signal Flow Diagram for a Two Port Network.

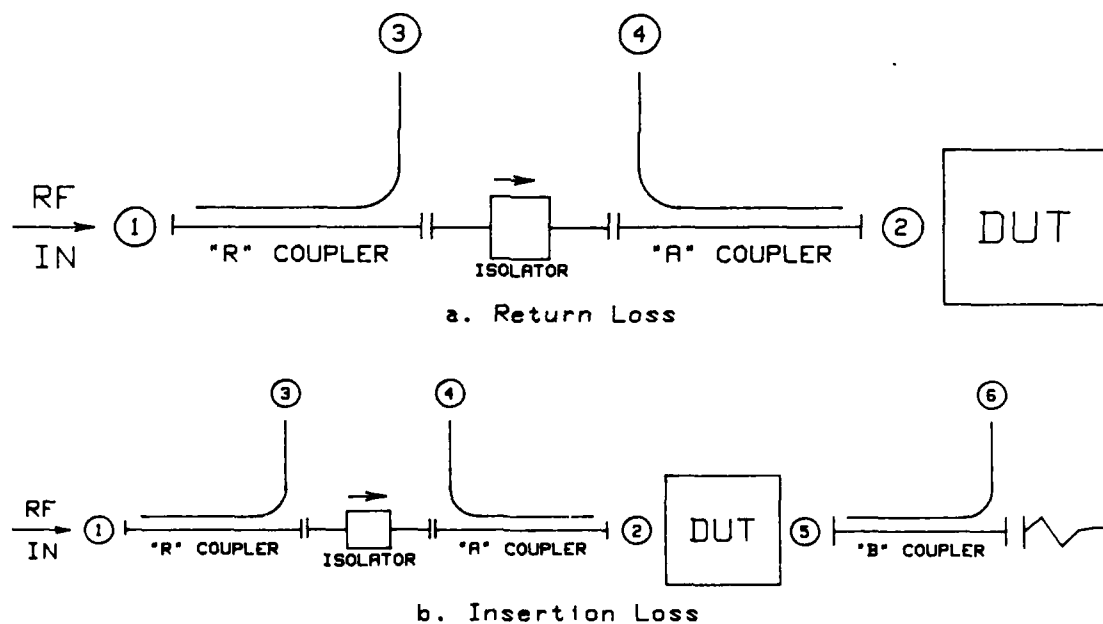

Figure 2. Basic Diagrams for Return and Insertion Loss Measurements.

$$RL_A = -10 \log_{10} |S_{11}|^2 \quad (2)$$

$$IL_{AB} = -10 \log_{10} |S_{21}|^2 \quad (3)$$

If the DUT is reversed, then the return loss at Port B and the insertion loss from Port B to Port A can be determined as follows:

$$RL_B = -10 \log_{10} |S_{22}|^2 \quad (4)$$

$$IL_{BA} = -10 \log_{10} |S_{12}|^2 \quad (5)$$

The scalar measurement system is designed to obtain the parameters which can be used to determine the magnitude of the scattering coefficients and finally the desired return and insertion losses.

Simplified diagrams of the reflectometers used for return loss measurements and insertion loss measurements are illustrated in Figures 2a and 2b respectively. The three couplers are referred to as the R, A, and B couplers since they provide samples of the incident (reference) signal, the signal scattered from Port A of the DUT, and the signal scattered from Port B of the DUT. Square-law detectors located at 3, 4, and 6 provide output voltages proportional to the RF-signal power scattered to these three ports. The return loss is determined from the ratio V_A/V_R , and the insertion loss is determined from the ratio V_B/V_R . In an ideal system, RL and IL could be determined directly from these quantities. In practice, however, these values are

corrupted by component differences and imperfections. It is necessary, therefore, to first calibrate the system and then accept some uncertainty when the measurement is taken. If the measurement uncertainties can be quantified, then some bounds of measurement uncertainty can be determined so that meaningful interpretation of the results can be made.

1. Return Loss Measurement Analysis

In general, the return loss from a DUT port, k, is given by:

$$RL_k = -10 \log_{10}(P_k^-/P_k^+) \quad (6)$$

where P_k^- is the power scattered from port k, and P_k^+ is the power incident on port k. The incident and reflected powers are detected at ports R and A respectively and the detector output voltages are sent to the scalar analyzer. Referring to Figure 2a, the ratio of detector voltages may be expressed in terms of the scattering coefficients of the reflectometer bridge as:

$$(V_A/V_R) = a^2 \left| \frac{S_{41}}{S_{42}} + S_{21}(1+S_{22}\Gamma_{in})\Gamma_{in} \right|^2 \quad (7)$$

where a^2 is a constant, and Γ_{in} is the input reflection coefficient of the DUT and where it has been assumed that $|S_{22}\Gamma_{in}| \ll 1$. It should be recognized that $|S_{21}| \approx 1$ and that $|S_{41}/S_{42}| \ll 1$ will be approximately equal to the directivity

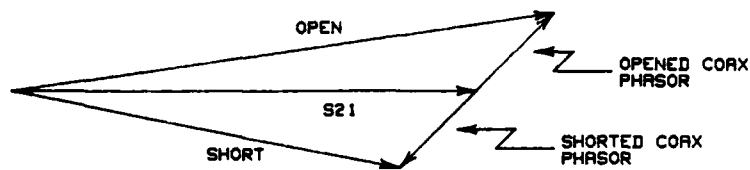

a. Coaxial Scalar Network Analyzer.

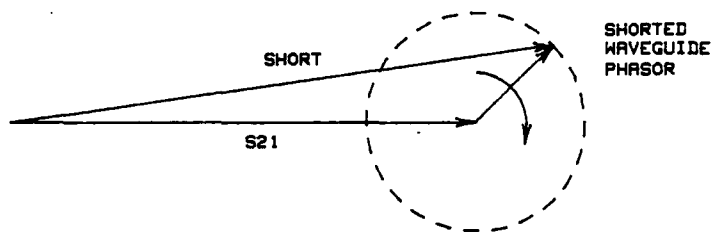

b. Waveguide Scalar Network Analyzer.

Figure 3. Phasor Diagrams for Establishing 0 dB Return-Loss Signal Level in Scalar Network Analyzers.

of the A coupler. However, the coupler directivity will always be an upper bound for $|S_{41}/S_{42}|$.

Before making a measurement, the 0 dB return loss reference level must be determined. In a coaxial scalar network system the reference value could be determined by substituting the DUT by a coaxial short followed by a coaxial open and measuring the respective return loss values. In this way the two extreme phasor components of the signal magnitude could be determined. As illustrated in Figure 3a, the 0 dB reference value could then be determined by the linear average of the shorted and open measurements.

Establishing the 0 dB return-loss reference level for a waveguide system is somewhat more involved, however,

since there is no waveguide equivalent to the open coaxial port. Equation (7) indicates that this level could be established through the use of a sliding waveguide short. In this case, $\Gamma_{in} = e^{j\theta}$ and, as the position of the short is varied, one obtains maximum and minimum readings for each measurement frequency (see Figure 3b)

$$\left(\frac{V_A}{V_R}\right)_{\text{cal max}}^{1/2} = a |S_{21}| (1 + |S_{22}|) + \delta \quad (8)$$

$$\left(\frac{V_A}{V_R}\right)_{\text{cal min}}^{1/2} = a |S_{21}| (1 - |S_{22}|) - \delta \quad (9)$$

where

$$\delta = C |S_{41}/S_{42}| \quad (-1 \leq C \leq +1). \quad (10)$$

If these readings are averaged as follows:

$$\begin{aligned} \left(\frac{V_A}{V_R}\right)_{\text{cal avg}}^{1/2} &= 1/2 \left[\left(\frac{V_A}{V_R}\right)_{\text{cal max}}^{1/2} + \left(\frac{V_A}{V_R}\right)_{\text{cal min}}^{1/2} \right] \quad (11) \\ &= a |S_{21}| \end{aligned}$$

the 0 dB return-loss reference level and Γ_{in} can be established for future measurements. Once this calculation has been made then the following can be determined:

$$\frac{\left(\frac{V_A}{V_R}\right)_{\text{cal max}}^{1/2} - \left(\frac{V_A}{V_R}\right)_{\text{cal min}}^{1/2}}{2 \left(\frac{V_A}{V_R}\right)_{\text{cal avg}}^{1/2}} = |S_{22}| + \delta \quad (12)$$

which will be useful in determining the measurement residual uncertainty. $|S_{22}|$ is the equivalent of the source mismatch, and is determined from (12) with uncertainty no greater than the A coupler directivity, S .

If the DUT is connected to port 2 of the A coupler, a measurement of the reflected power from the input port of the DUT can be made. There is no control over the phase of the reflected power. It can be shown, therefore [Ref. 3:p. 185],

$$\frac{(V_A/V_R)_{DUT}^{1/2}}{(V_A/V_R)_{cal}^{1/2}} = |\Gamma_{in}| + C_1 \left| \frac{S_{41}}{S_{42}S_{21}} \right| + C_2 |S_{22}| |\Gamma_{in}|^2. \quad (13)$$

The constants C_1 and C_2 lie in the interval $[-1,1]$ and depend upon the phases of the directivity and equivalent source mismatch error signal components relative to the signal reflected from the input of the DUT. $|S_{22}|$ was found during the calibration and it is assumed that $|S_{21}| \approx 1$. $|S_{41}/S_{42}|$ is not generally known as a function of frequency but it is bound from above by the coupler directivity, D , as specified by the manufacturer. The detector voltage ratios may now be determined by

$$\frac{(V_A/V_R)_{DUT}^{1/2}}{(V_A/V_R)_{cal}^{1/2}} = |\Gamma_{in}| \pm \Delta\Gamma_{in} \quad (14)$$

where the worst case uncertainty $\Delta\Gamma_{in}$ is given by

$$\Delta\Gamma_{in} = D + |S_{22}| |\Gamma_{in}|^2 \quad (15)$$

In order for the proper 0 dB return-loss reference level to be determined for all phases of the input signal, the sliding short must be moved through a distance of at least one half of the guide wavelength, λ' . This will ensure that the signal passes through a full 360° of phase as illustrated in Figure 3b. The calibration algorithm can then determine the maximum and minimum values of (V_A/V_R) at each desired frequency as the sliding short is moved through a distance of $\lambda'/2$ at the lowest frequency in a specified number of steps, in this case 10. These values can also be used to compute the range of error for each measurement.

Interaction between the DUT, the source and the R coupler can be minimized through the use of a waveguide isolator between the R and A couplers. This will also minimize the equivalent source mismatch, $|S_{22}|$.

As a final note, the measured DUT input reflection coefficient is given by

$$\Gamma_{in} = S_{11}^{DUT} + \frac{S_{12}^{DUT} S_{21}^{DUT} \Gamma_L}{1 - S_{22}^{DUT} \Gamma_L} \quad (16)$$

where Γ_L is the reflection coefficient of the load terminating the DUT (Ref. 3:p. 185) Since $|\Gamma_{in}| = |S_{11}|$ for

the DUT only if $|\Gamma_L| = 0$, the best possible load should be placed on port B of the DUT when measuring $|\Gamma_{in}|$ at port A, and vice versa. To achieve the lowest uncertainty for return-loss and insertion-loss data, the unexcited port of the DUT should be terminated in a waveguide matched load. If a sliding load is used then the error due to load reflection may be averaged out in the same manner as the equivalent source mismatch error is averaged out during the return-loss calibration procedure. This will cause the process to be less automated, however, and some compromise may be necessary if a computer driven measurement system is desired.

2. Insertion Loss Measurement Analysis

Determining the insertion loss requires satisfying the equation

$$IL_{kq} = -10 \log_{10}(P_q^-/P_k^+) \quad (17)$$

where P_q^- is the power scattered from port q of the DUT and P_k^+ is the power incident on port k of the DUT. Looking at the basic setup in Figure 2b, this measurement is taken by terminating the network in the B-coupler and samples of the incident and scattered waves are coupled to ports R and B respectively. The square-law detectors at 3 and 6 produce the output voltages V_B and V_R . It can be shown that the ratio of these detector voltages in terms of the scattering coefficients of the DUT is given by

$$(V_B/V_R)^{1/2} = d \frac{|S_{21}^{DUT}|}{|(1-S_{11}^{DUT}\Gamma_s')(1-S_{22}^{DUT}\Gamma_L')-S_{12}^{DUT}S_{21}^{DUT}\Gamma_s'\Gamma_L'|} \quad (18)$$

where d is a constant, Γ_s' is the reflection coefficient seen looking into port 2 of the A coupler, and Γ_L' is the reflection coefficient seen looking into port 5 of the B coupler (Ref. 3:p. 185). Calibration of the reflectometer for this measurement is done by placing the A and B couplers directly together. This results in the following relationships:

$$S_{11} = S_{22} = 0 \quad (19)$$

$$S_{12} = S_{21} = 1. \quad (20)$$

As a result

$$(V_B/V_R)^{1/2} = \frac{d}{|1 - \Gamma_s'\Gamma_L'|} \quad (21)$$

and the correct reference level (0 dB insertion loss) is located with an uncertainty equal to $d|\Gamma_s'\Gamma_L'| \ll d$. The uncertainty can be reduced by making either Γ_s' or Γ_L' smaller which can be accomplished by removing the A-coupler during calibration and measurement for insertion loss. When this is done, $|\Gamma_s'|$ is determined solely by the isolator VSWR.

The location of the insertion loss reference level will have a worst case uncertainty determined by the system

component specifications. With the A-coupler in the system, the reflection coefficients Γ_s' and Γ_L' seen looking into the A and B couplers respectively are given by

$$\Gamma_s' = S_{22} + \frac{S_{24}S_{42}\Gamma_{D4}}{1 - S_{22}\Gamma_{D4}} \quad (22)$$

$$\Gamma_L' = S_{55} + \frac{S_{65}S_{56}\Gamma_{D6}}{1 - S_{66}\Gamma_{D6}} \quad (23)$$

In each case the coupler port is effectively terminated (A-coupler by the isolator, B-coupler by the load). This makes each coupler appear as a 2-port network terminated in loads Γ_{D4} and Γ_{D6} respectively. As a result, the best possible results will occur when the detectors exhibit the lowest possible VSWR. Unfortunately millimeter-wave detectors generally have high VSWR's so an isolator with a lower VSWR preceding the detector may be necessary. Keep in mind that the secondary arm of the coupler will reduce the coupling factor by about 10 dB typically. The values of $|\Gamma_s'|$ and $|\Gamma_L'|$ for the reflectometer setup used in this paper are given in Chapter II, page 24.

The 0 dB reference uncertainty can be bounded more tightly by measuring the return loss of the B coupler during calibration. This will establish $|\Gamma_L|$. $|\Gamma_s|$ can be determined from the value of $|S_{22}|$, which was found during the return loss calibration (Equation 12) and Γ_{D4} from

manufacturer specifications. It can be shown that the calibration uncertainty is

$$20 \log_{10}(1 + |\Gamma_s' \Gamma_L'|) \quad (24)$$

which is reduced since $|\Gamma_L'|$ is known from direct measurement at each frequency of interest (Ref. 3:p. 187).

With the DUT inserted between couplers A and B the insertion loss is determined by

$$\frac{(V_A/V_R)_{DUT}^{1/2}}{(V_B/V_R)_{DUT}^{1/2}} = \left[\frac{|1 - \Gamma_s' \Gamma_L'|}{|1 - S_{11}^{DUT} \Gamma_s'| (1 - S_{22}^{DUT} \Gamma_L') - S_{12}^{DUT} S_{21}^{DUT} \Gamma_s' \Gamma_L'|} \right] |S_{21}|. \quad (25)$$

Since there is no control over the DUT scattering coefficients, the measurement error depends upon Γ_s' and Γ_L' . Accurate measurements require the minimization of these two values.

In an automated system the value of the measurement along with the computed maximum and minimum measurement uncertainty can be easily graphed. This provides an easy graphical picture of the DUT response which can provide an immediate evaluation of the device performance.

II. SYSTEM DESCRIPTION

The Millimeter-Wave Scalar Network Analyzer system used for this thesis is illustrated in Figure 4. Specific Reflectometer components are listed in Table I. The full band sweeper and reflectometer are essentially the same as before but a new Schottky barrier detector diode was used in the A-coupler. The Reflectometer components yield a $|\Gamma_S| \leq 0.30$ and a $|\Gamma_L| \leq 0.12$ (Refs. 2,3). The other major components are described below.

The new mainframes required software modification for proper computer interfacing. Conspicuous by its absence is the analog-to-digital converter which was eliminated by using the new mainframes. Although software modifications were required to communicate properly between mainframes, the computations used for determining the return loss and insertion loss remained essentially the same. Details on specific software modification are contained in the third section of this chapter.

A. Hardware

The five major components used for the Automated Millimeter-Wave Scalar Network Analyzer are as follows.

1. Computer: The HP-9845B microcomputer was used for this setup. Its 186K memory was sufficiently large for all storage and computational requirements. It was the

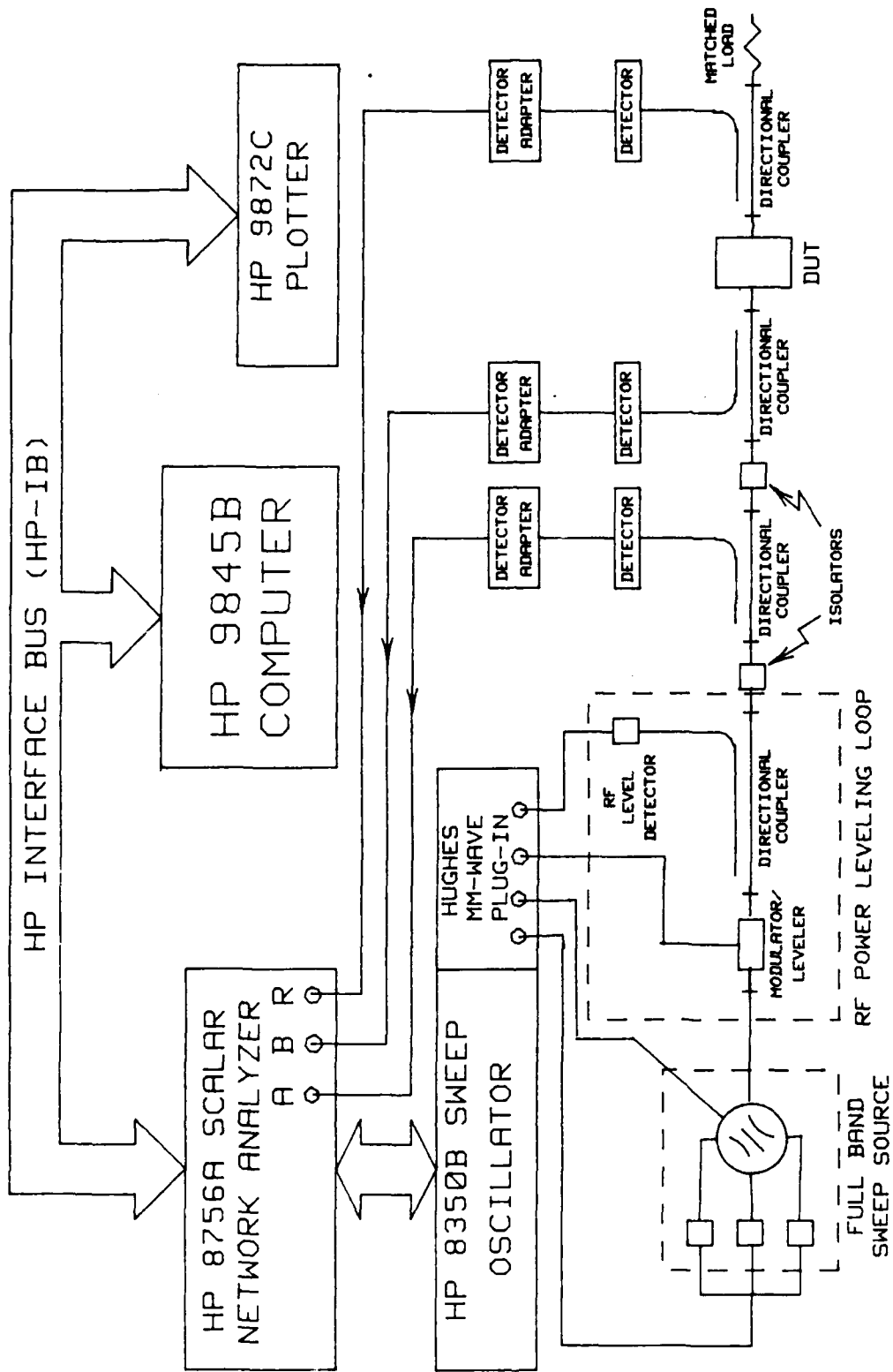

Figure 4. Diagram of an Automated Millimeter-Wave Scalar Network Analyzer System.

computer used for the original setup and software modifications were minimal and easily incorporated. The internal thermal printer was used for text output and could also be used for graphical output if desired.

2. Sweeper Controller: One of the new mainframes used for this setup, the HP-8350B, was interfaced with the HP-9845B computer through the HP-8756A Scalar Network Analyzer. The HP-8350B could be controlled either locally or remotely through the entire 60-90 GHz band by using the Hughes 47610H Millimeter-Wave Plug-In. One major advantage of the HP-8350B was the ability to switch the RF head on the Full Band Sweeper automatically through proper frequency selection. No separate band selection commands were required from the software. The primary disadvantage was that the entire millimeter band from 60-90 GHz could not be swept with a single command. In order to execute a full band sweep, the computer had to command a sweep from 60-70 GHz, then from 70-80 GHz, and finally from 80-90 GHz. This was necessary to activate the proper RF head in the Full Band Sweeper.

3. Millimeter Wave 60-90 GHz Full Band Plug-In: The Hughes 47610H Full Band Plug-in which was used in the original setup was used again for this setup. An adapter piece along with a ROM chip from Hughes Aircraft Company was required for proper interfacing with the HP-8350B Sweeper

Controller. The conversion was easily accomplished and no subsequent problems have occurred.

4. Scalar Network Analyzer: The HP-8756A Scalar Network Analyzer was the most important improvement to the system. Although the analyzer could be operated independently, its connection with the computer through the interface bus (HP-IB) allowed for complete computer control of all analyzer functions. The HP-8756A also had the ability to digitize the display sweep and transfer the values to the HP-9845B for storage and computations. The results using this analyzer were very good although there was one drawback. The display sweep is digitized to 401 points regardless of the START/STOP frequencies. This meant that great care had to be used for measurements taken nonsymmetrically around a band switch point. For example, to sweep from 65-72 GHz first requires the sweep from 65-70 GHz, then the sweep from 70-72 GHz since 70 GHz is the band switching point. The HP-8756A, therefore, will digitize the first sweep of 5 GHz (65-70 GHz) into 401 points and send that to the computer. It will then digitize the remaining 2 GHz (70-72 GHz) into 401 points and send that to the computer. As one can see, the result is that for the same frequency range in each band there are going to be a different number of samples taken resulting in accuracy differences. The easiest way to avoid this problem is to insure that the frequency width taken in each band is the

same, i.e., insure that the START/STOP frequencies are symmetrical about the band switch frequency.

5. Plotter: The HP-9872 series Plotter was a totally new addition to the system. In the previous system, the graphical output was only available from the HP-9845B internal thermal printer. This method was very quick, but all too often produced a copy which obscured the actual measured value and the bounds of uncertainty.

With only a few lines of code the user now has the capability of producing a larger, high resolution, multi-color output of the graphical data. By utilizing the fine tip pens and multi-color capability of HP-9872 plotter, even the tightest bounds to the actual reading came out dramatically clearer than with the thermal printer.

All of the graphical results in this paper were done on the HP-9872C Plotter. Although the plotter image takes longer to produce, this feature was a major improvement over the old system.

The Reflectometer components used for the measurements as well as the variable attenuator, sliding short and matched load used as DUTs are listed in Table I.

B. SYSTEM CONNECTION

Figure 4 shows the measurement system interconnections. The HP-IB connects the HP-8756A Scalar Network Analyzer mainframe and the HP-9872C Plotter with the HP-9845B

TABLE I

SPECIFIC REFLECTOMETER COMPONENTS USED FOR THE
AUTOMATED MILLIMETER-WAVE SCALAR NETWORK ANALYZER

Component	QTY	Manufacturer	Part number
Full Band RF Source	1	Hughes	47125H-1100
Modulator/Leveler	1	Hughes	45215H-1100
Directional Coupler	4	Hughes	45325H-1010
Diode Detector	3	Hughes	47325H-1100
Diode Detector	1	Hughes	47325H-1111
Detector Adapter	3	H/P	11664C
Isolators	2	Hughes	45115H-1000
Variable Attenuator	1	Hughes	45725H-1000
Sliding Short	1	Baytron	3E-95
Matched Load	1	Hughes	45615H-1000

computer. The HP-8350B Sweeper Controller is connected via external bus to the HP-8756A. All computer commands for the sweeper pass through the analyzer.

The Hughes 47610H Millimeter-Wave Plug-in is internally connected to the Sweeper Controller with external connections to the Full Band RF Head for band selection and RF power control. Detector voltage outputs are fed through an adapter where the signal is amplified and impedance matched to the HP-8756A input. Power ratio measurements are displayed on the analyzer scope. The scope sweep is then digitized into 401 points and sent to the computer via the HP-IB. All computations for return and/or insertion loss are performed by the computer and the results outputted to

either the CRT, internal thermal printer or externally through the HP-IB to the HP-9872C plotter.

C. SOFTWARE

The old Millimeter-Wave Scalar Network Analyzer used a program entitled "AEK" which was developed by Lieutenant Elia Gatsos, Hellenic Navy (Ref. 4:pp. 78-94). The analog nature of the HP-8755B Scalar Network Analyzer precluded sweeping the band of interest continuously since the analyzer output could not provide a digitized sweep output to the HP-9845B computer. The band had to be divided into individual frequencies spaced across the desired band in steps which were selected by the user; 100 MHz for example. With the HP-8620C Sweeper Controller in the CW mode (vice FREQUENCY SWEEP mode), the computer would send the individual frequencies to the Sweeper Controller. At each step the output from the HP-8755B would be routed through the A/D converter to the computer where it would be stored in an array.

In the new system, the HP-8756A Scalar Network Analyzer has the capability of digitizing a sweep and outputting the measured values directly to the HP-9845B computer as a serial string of values which can be read directly into an array. The sweep is always digitized into 401 points. The program had to be modified to provide for this increased

capability. The commands were much simpler and arrays could be initiated with a maximum number of 401 points.

The HP-8350B Sweeper Controller required a few extra commands to ensure only one band was swept at a time. The only way to position the RF head on the Reflectometer to the proper position was to have the START/STOP frequencies fall within a particular band. This meant that to sweep across the entire band from 60-90 GHz required three series of commands from the computer; 60-70 GHz, 70-80 GHz and 80-90 GHz.

To provide consistency in the measurements, 401 points were always used. For a sweep in one band this was no problem. When sweeps across two or three bands were required, some data manipulation was required to ensure equally spaced data points between the start and stop frequencies. Additional computer commands were required, therefore, for processing the HP-8756A data.

Handling 401 data points provided excellent results but required lengthy computations for calibration and measurement (due to a number of looping operations). To allow for faster computation times at the expense of resolution, a selection of 7 choices for total number of data points used was provided for the user. The lowest number, 10, was used for trouble shooting the program. Computations were very fast but the results were not of much use for actual measurements. The remaining numbers, up to

401, give increasing degrees of resolution and longer computation times. The user must determine the number of points versus computation time required for a particular measurement.

The final major program modification involves adding a feature which was not previously available. The internal thermal printer will produce a graphic representation of the measurement (return loss or insertion loss). At times the measurement and the boundaries for the range of error become so close that it is difficult to distinguish between them. It would be helpful to have a larger, clearer graphic image.

With this in mind, the capability of plotting the graphic image on the HP-9872 plotter was incorporated into the program. The image can be as large as the plotting surface (11" x 17") and can have up to 4 colors for greater clarity. This feature proved very successful and greatly enhanced the output capabilities of the system.

Other minor program modifications were added to provide for more user friendliness. During the sliding short calibration all data is taken before the 0 dB return loss reference level is computed. This reduces the user interfaced time required to move the position of the sliding short.

The measurement sequence for insertion loss in the old program was the same with or without the A-coupler in the system. With the A-coupler in the system, the sequence was

rearranged to provide fewer user interfaces resulting in a faster measurement process.

The number and magnitude of program modifications justified renaming the program from "AEK" to "MMWSNA". A flow chart of the program is shown in Figure 5.

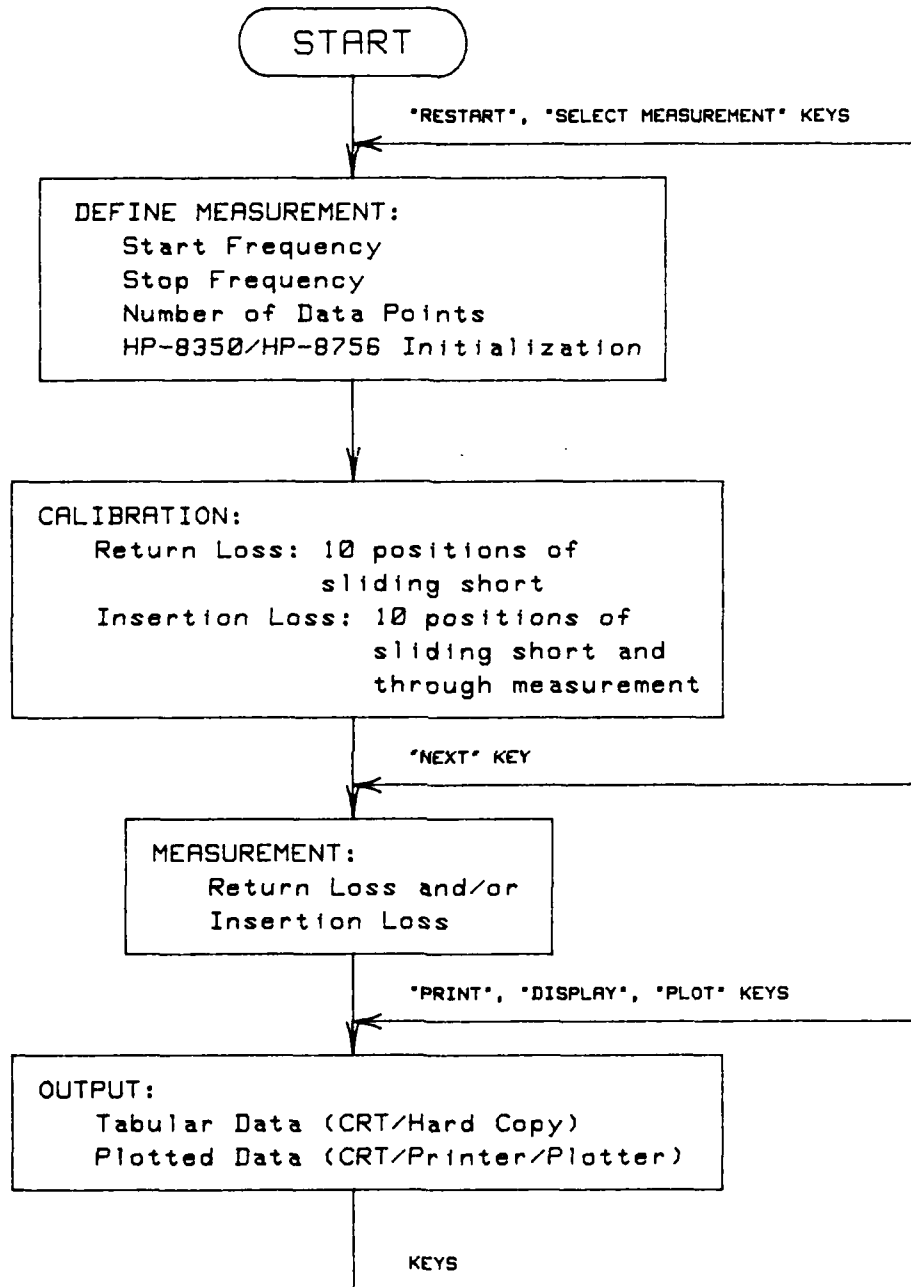

Figure 5. Measurement Flow Chart for "MMWSNA" Program.

III. RESULTS

The number of tests which were used to verify the performance of the improved Millimeter-Wave Scalar Network Analyzer precludes reviewing all of them in this paper. A representative sample have been chosen to illustrate the return loss and insertion loss capabilities and many more were used to determine certain system parameters such as dynamic range. This chapter reviews the measurements and provides illustrations to characterize them. Accuracy measurements with the improved analyzer also include tabular data. Some comparisons will also be made so that the improved system data can be compared with data gathered in previous theses, known systems, and manufacturers' components. The MMWSNA User Guide (Appendix A) may be helpful as a reference.

A. RETURN LOSS MEASUREMENTS

As mentioned in the Chapter 1, Section C, the analyzer must be calibrated prior to performing measurements for return loss. The system was calibrated using a sliding short. The short was moved to ten different positions ensuring that the short was positioned over a length greater than 2.5 millimeters which is equal to $\lambda/2$ at 60 GHz. Sufficient accuracy is attained using 100 to 200 data points for the measurements thus reducing the calculation times. Aside from user inputs to the program and moving the sliding

short, the computer performs all the setup, data gathering, and calculations for establishing the 0 dB return loss reference point.

1. Calibration

To ensure that the system was properly calibrated, measurements of a short and a matched load were performed. Expected return loss values of 0 dB and some maximum value in excess of 30 dB were expected for the short and load respectively. The first measurements were performed with the existing whisker diode detectors and yielded the return losses shown in Figures 6 and 7. In the measurement plots, the middle curve is the actual device measurement and the upper and lower curves bound the measurement uncertainty. The fixed short return loss looked good but the matched load return loss was a disappointing 20 dB. Subsequent system checks and measurements made with a calibrated attenuator verified that the system was working properly but the maximum measurable return loss was about 20 dB.

Defective detector diodes were believed to be the cause of the poor system performance. A newer Schottky barrier diode detector was purchased from Hughes Aircraft Company (Serial no. 030). The performance of this detector was much improved. Figures 8 and 9 show the return loss for the short and matched load return losses respectively.

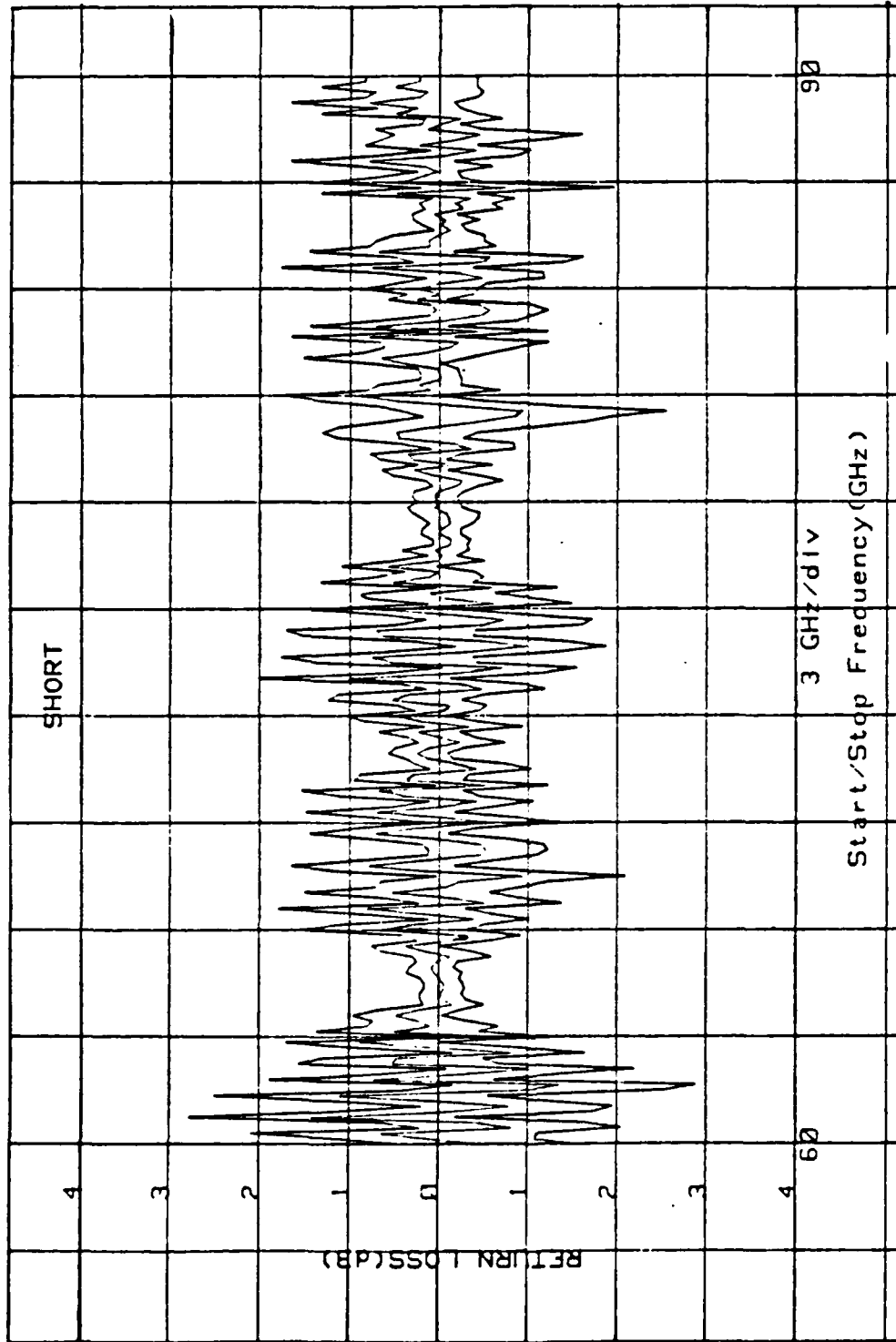

Figure 6. Fixed Short Return Loss Using Whisker Diode Detector.

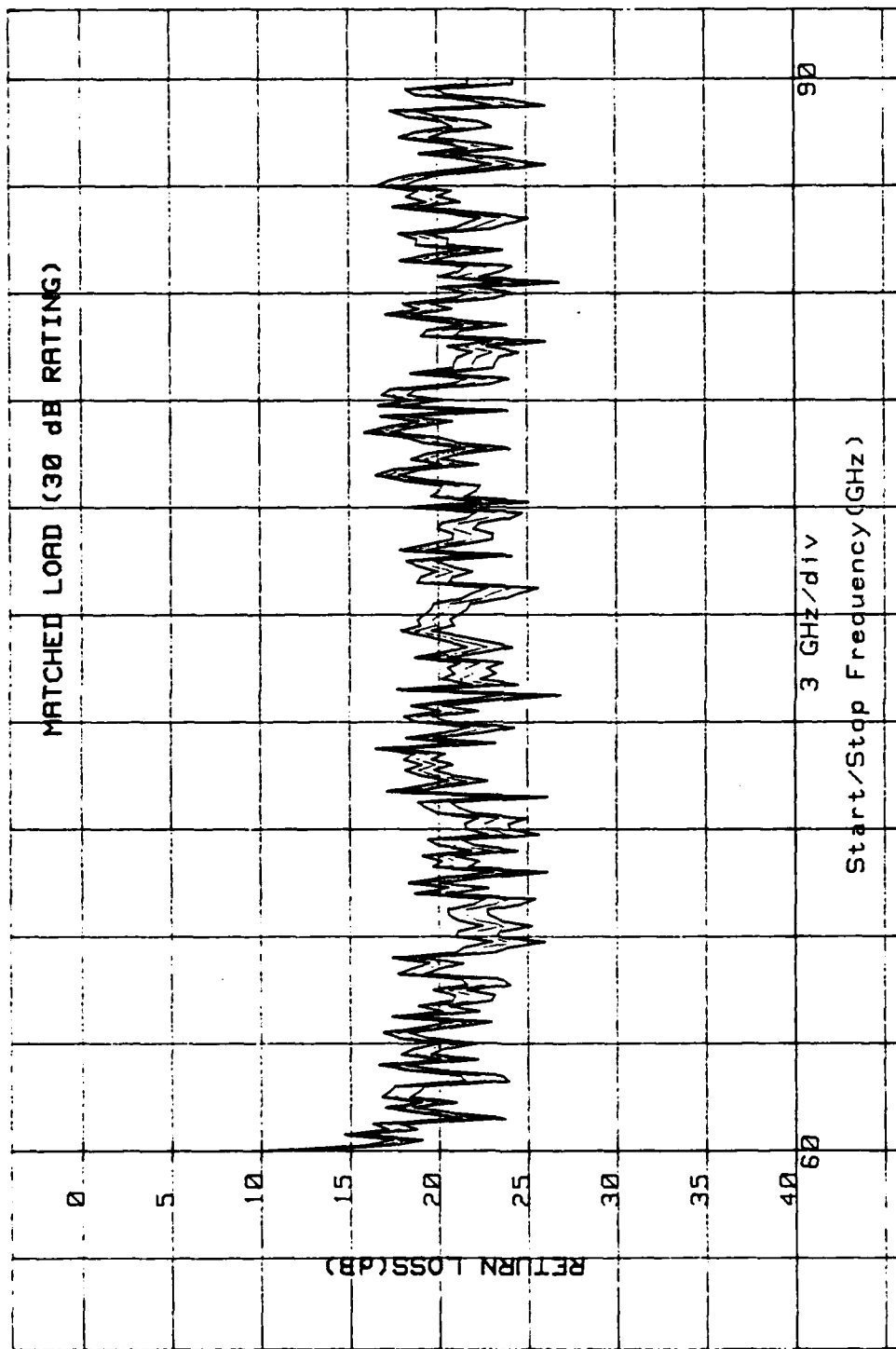

Figure 7. Matched Load Return Loss Using Whisker Diode Detector.

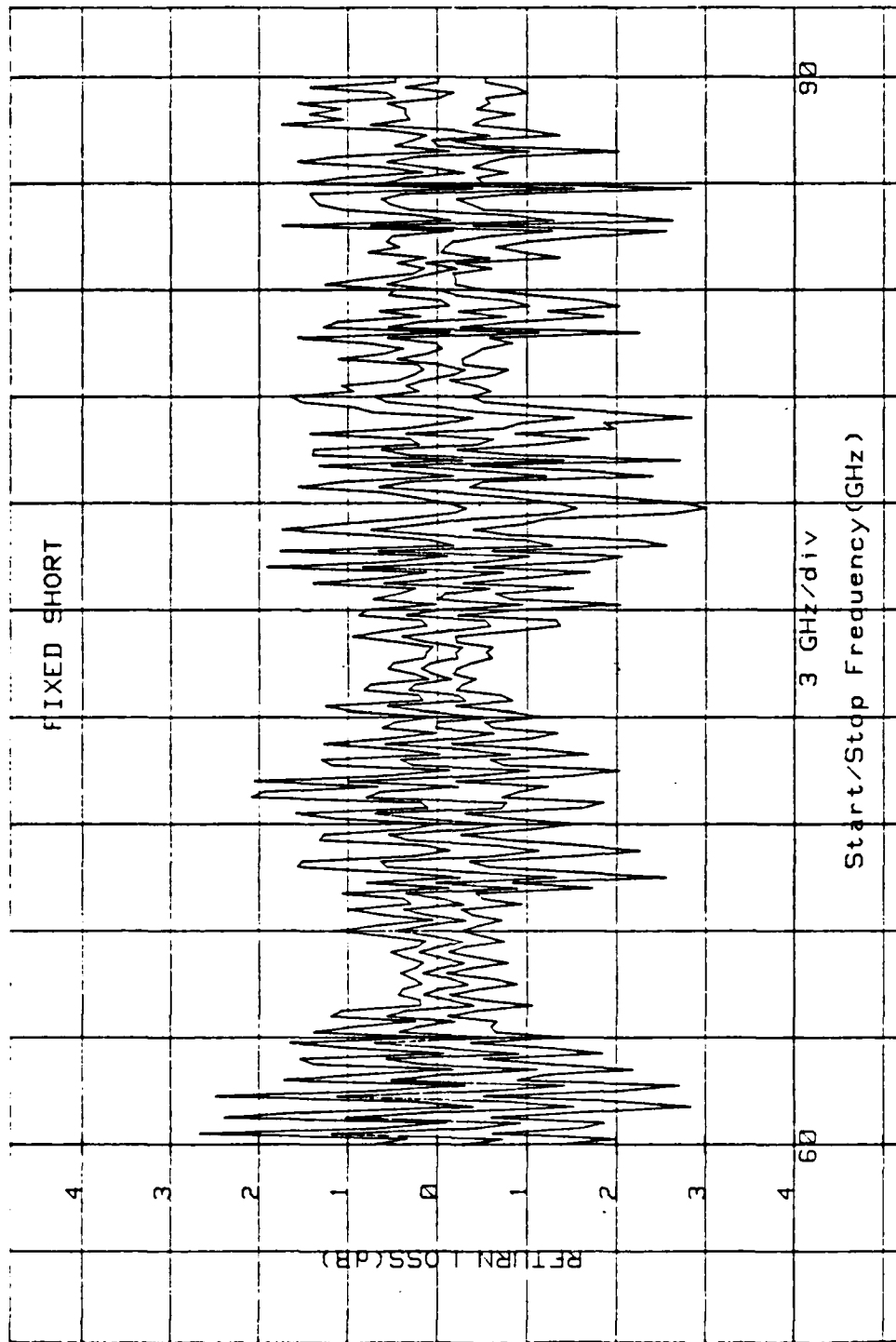

Figure 8. Fixed Short Return Loss Using Schottky Diode Detector.

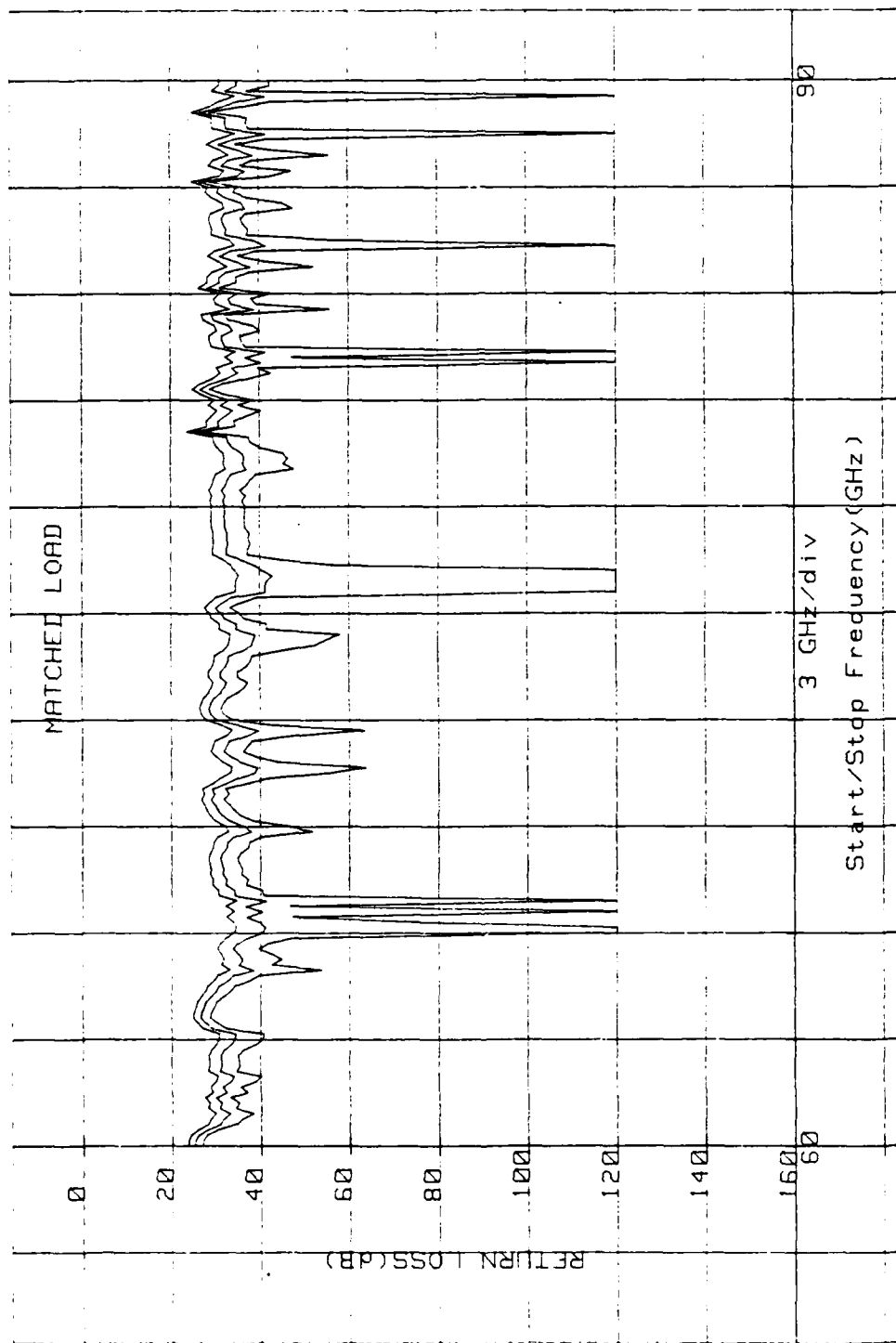

Figure 9. Matched Load Return Loss Using Schottky Diode Detector.

The printed tabular data can be found in Appendix C, Tables II and III. The Schottky barrier diode detector appeared to have a much better dynamic range.

a. Minimum Uncertainty Computation Problem

Graphical results from the Matched Load return loss (Figure 9) showed discontinuities at various points associated with the Minimum Uncertainty plot. A more detailed study shows that the discontinuity occurs when the return loss exceeds 40 dB. Analysis of the equations used to determine return loss uncertainty reveals the problem.

In Chapter I Section A, the return loss worst case uncertainty, $\Delta\Gamma_{in}$, was given by Equation (15). This calculation is performed at line 4170 of the "MMWSNA" program. The variable cross reference between Equation (15) and "MMWSNA" is as follows:

$$\Delta\Gamma_{in} = R3(X)$$

$$S_{22} = R6(X)$$

$$\Gamma_{in} = R19(X)$$

$$D = 0.01 \text{ (Manufacturer specification [Ref. 2:p. 104])}$$

Equation (15) and line 4170 compute the worst case uncertainty, $\Delta\Gamma_{in}$ and $R3(X)$ respectively, by using the worst case value of D , that being the Manufacturer's specification. When a high return loss occurs, the computed value of the worst case uncertainty, $R3(X)$, can exceed the value of the input reflection coefficient, $R19(X)$. In this

case the computation for the minimum uncertainty, R5(X), results in the logarithm argument being negative and, therefore, meaningless resulting in a discontinuity ("MMWSNA" line 4240).

As an example, in Table III the values of the variables for the matched load return loss at 66.00 GHz are as follows:

$$\begin{aligned}\Gamma_{in} &= -40.25 \text{ dB or } 9.71628 \times 10^{-3} \\ S_{22} &= -23.57 \text{ dB or } 66.298 \times 10^{-3} \\ D &= 0.01\end{aligned}$$

Using these values the worst case uncertainty is:

$$\begin{aligned}\Delta\Gamma_{in} &= (9.71628 \times 10^{-3})^2(66.298 \times 10^{-3}) + 0.01 \\ &= 10.00626 \times 10^{-3}\end{aligned}$$

The minimum uncertainty (R5(X)) = $20 \log_{10}(\Gamma_{in} - \Delta\Gamma_{in}) = 20 \log_{10}(-289.98 \times 10^{-6})$ which is, of course, meaningless. To bypass this problem a default value of 120 dB was given to R5(X) for these cases ("MMWSNA" lines 4240 and 4250). The interpretation of this result is that there is a minimum value of uncertainty but it cannot be evaluated using the worst case coupler directivity. The value of the directivity for the coupler at that frequency would have to be known. For return losses of this magnitude, however, the parameter of greatest interest is normally the maximum

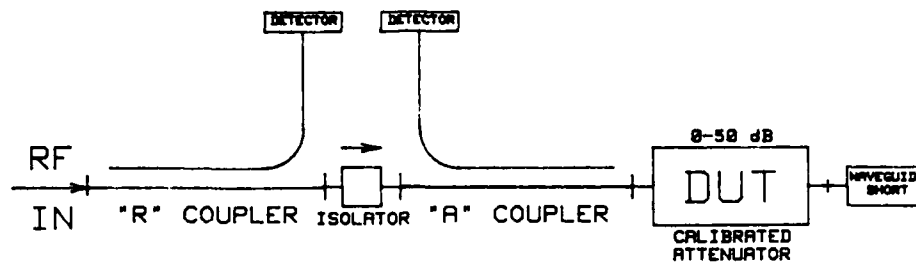

Figure 10. Calibrated Return Loss Setup.

return loss uncertainty and not knowing the minimum uncertainty is usually inconsequential.

2. Return Loss Accuracy

To gather data concerning the accuracy of the system for return losses throughout the dynamic range, a DUT consisting of a calibrated attenuator with a short at the output was used. The attenuator was a Hughes 4572xH series Millimeter-Wave Direct Reading Attenuator which has a specified accuracy of 0.1 dB or 0.2 percent, whichever is greater [Ref 2:pp. 34-35]. The setup is illustrated in Figure 10. The RF signal is attenuated twice; once as it passes through the attenuator to the short and again by an equal amount (the attenuator is a reciprocal device) as it returns from the short through the attenuator and into the A-coupler where it is detected. The return loss should be twice the attenuator setting. The return loss using the whisker diode for attenuator settings of 5 dB, 10 dB, and

12.5 dB are illustrated in Figures 11, 12, and 13 respectively.

The Schottky detector return losses for attenuator settings of 5 dB, 10 dB, 15 dB and 18 dB are shown in Figures 14, 15, 16 and 17. Printed outputs can be found in Appendix C, Tables IV, V, VI and VII. From this data the Schottky detector appears to have a much better dynamic range although in both cases the Return Loss did not stay within the specified accuracy of the attenuator.

3. Dynamic Range

To show the improved performance of the Schottky diode, values of return loss for 65 GHz, 75 GHz and 85 GHz were obtained and plotted to determine and compare dynamic ranges. The results are shown in Figure 18. It is not difficult to see from these graphs the superior performance of the Schottky barrier diode detector. Moreover the dynamic range for the Schottky diode is about 35-40 dB which is easily as good as that of commercially available systems.

a. Diode Detector Comparison

The reason for the superior performance of the Schottky diode detector is not immediately evident. An analysis of the output voltage was conducted and some clues as to the reason were revealed.

In a series of separate measurements, an oscilloscope was connected to two different whisker diode detector outputs and the Schottky barrier diode detector

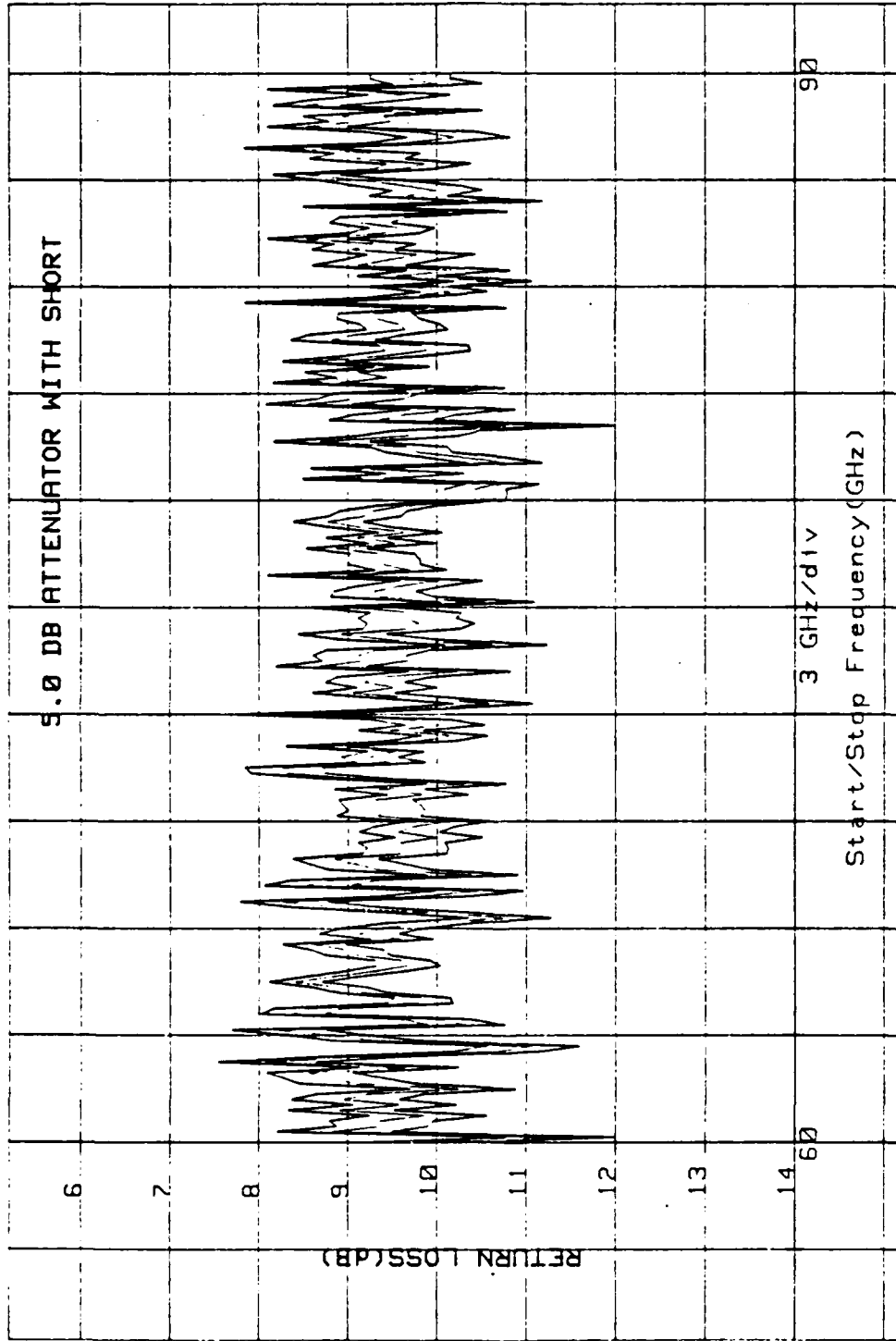

Figure 11. Return Loss for 5 dB Attenuator With Shorted Output Using Whisker Diode Detector.

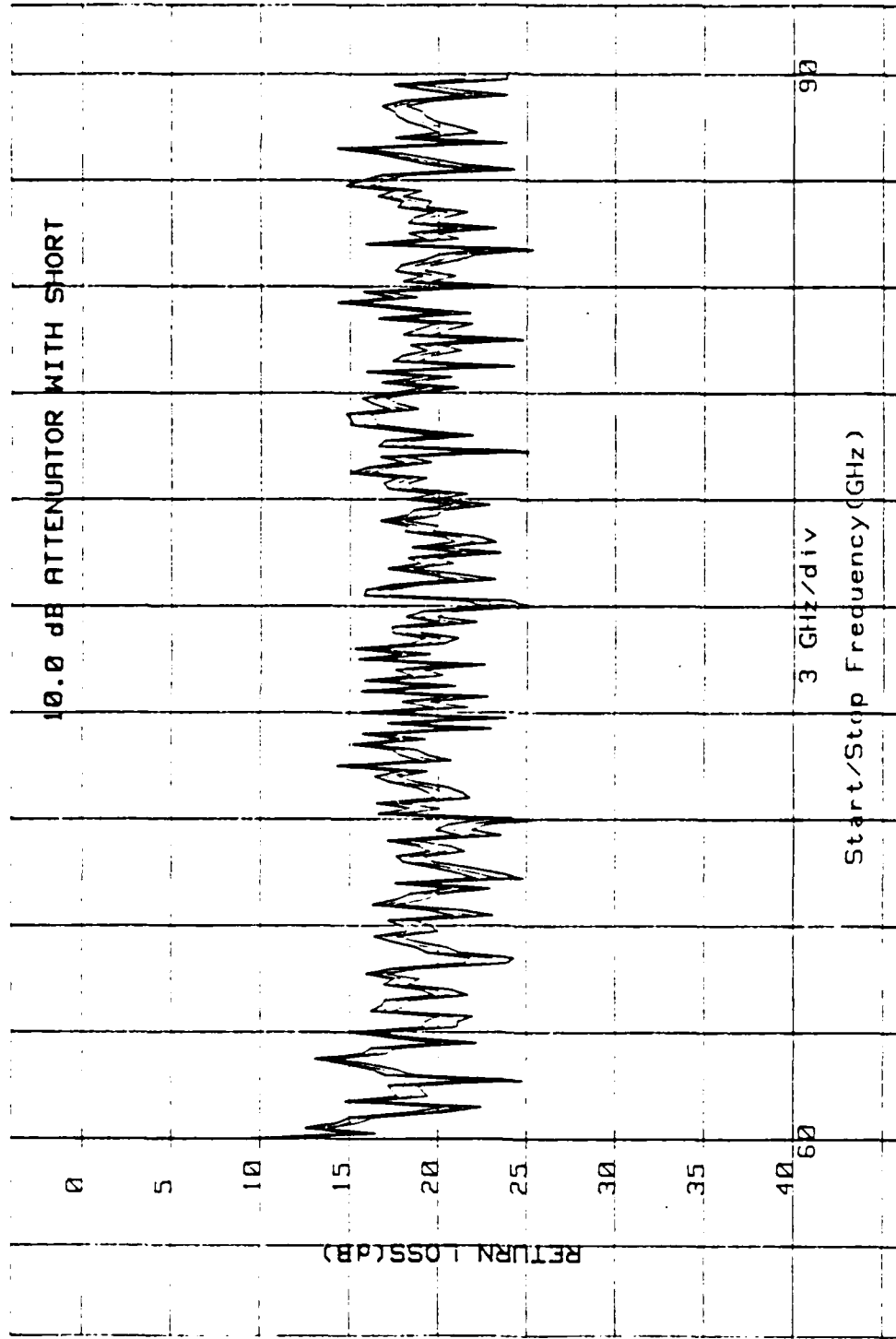

Figure 12. Return Loss for 10 dB Attenuator With Shorted Output Using Whisker Diode Detector.

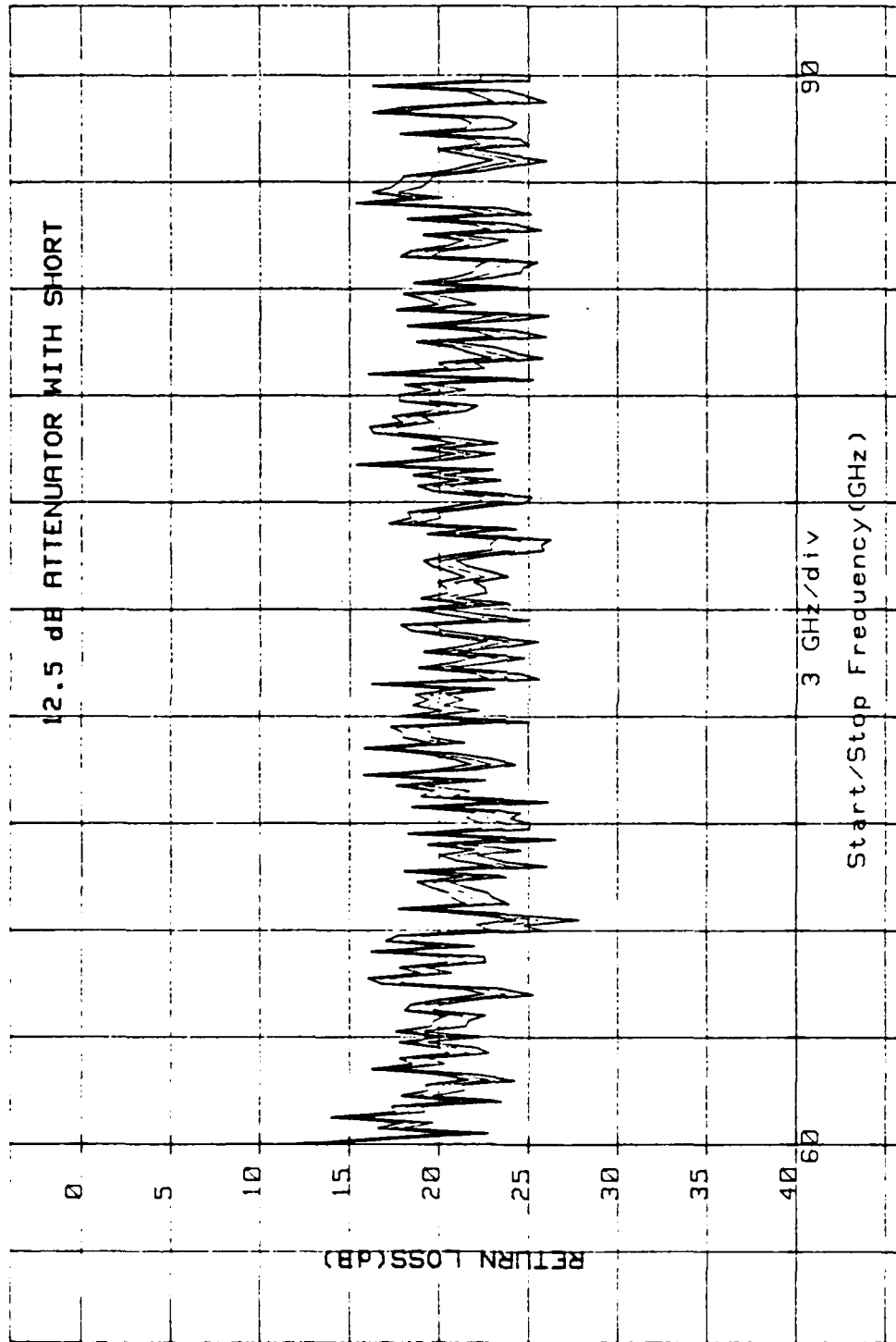

Figure 13. Return Loss for 12.5 dB Attenuator With Shorted Output Using Whisker Diode Detector.

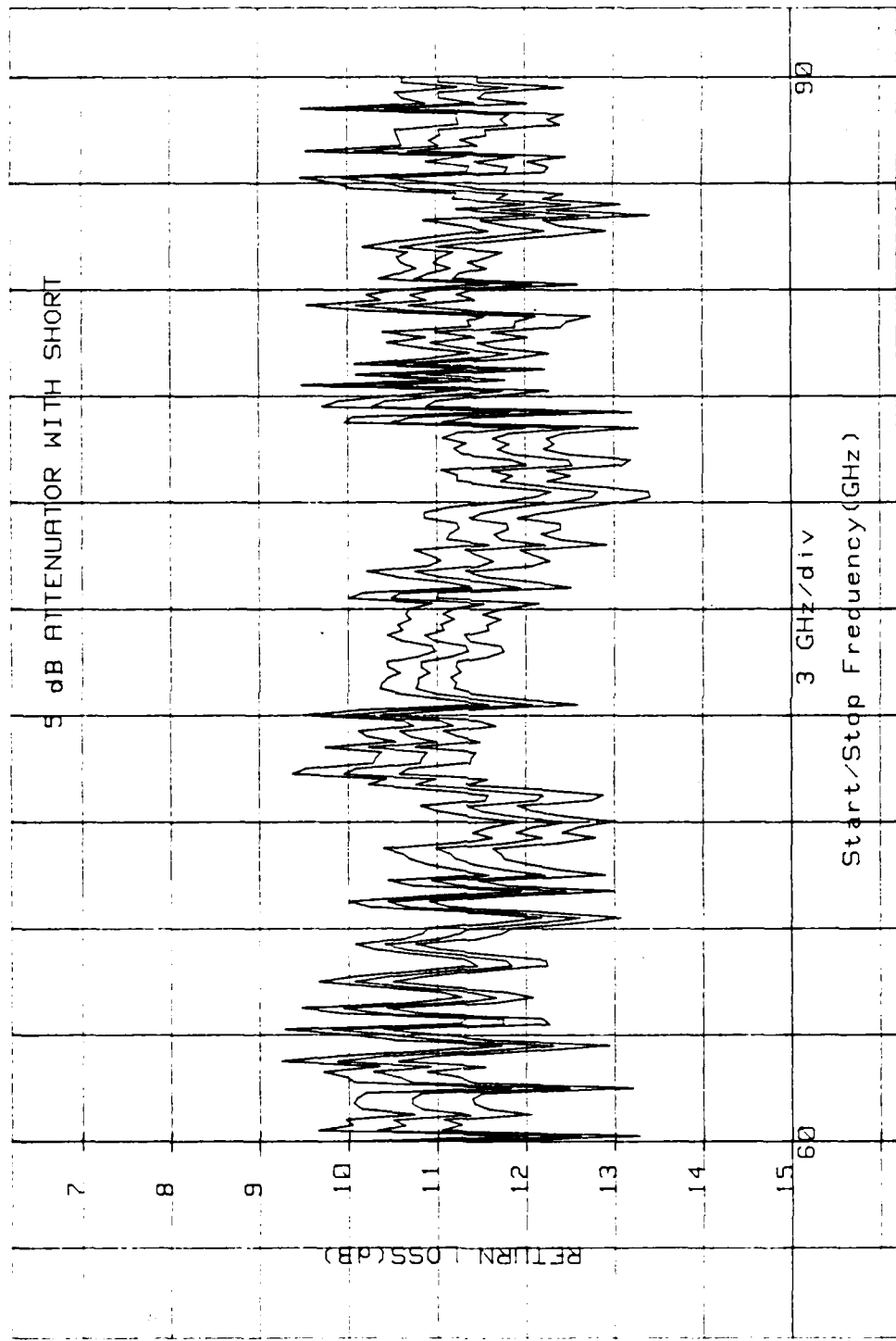

Figure 14. Return Loss for 5 dB Attenuator With Shorted Output Using Schottky Diode Detector.

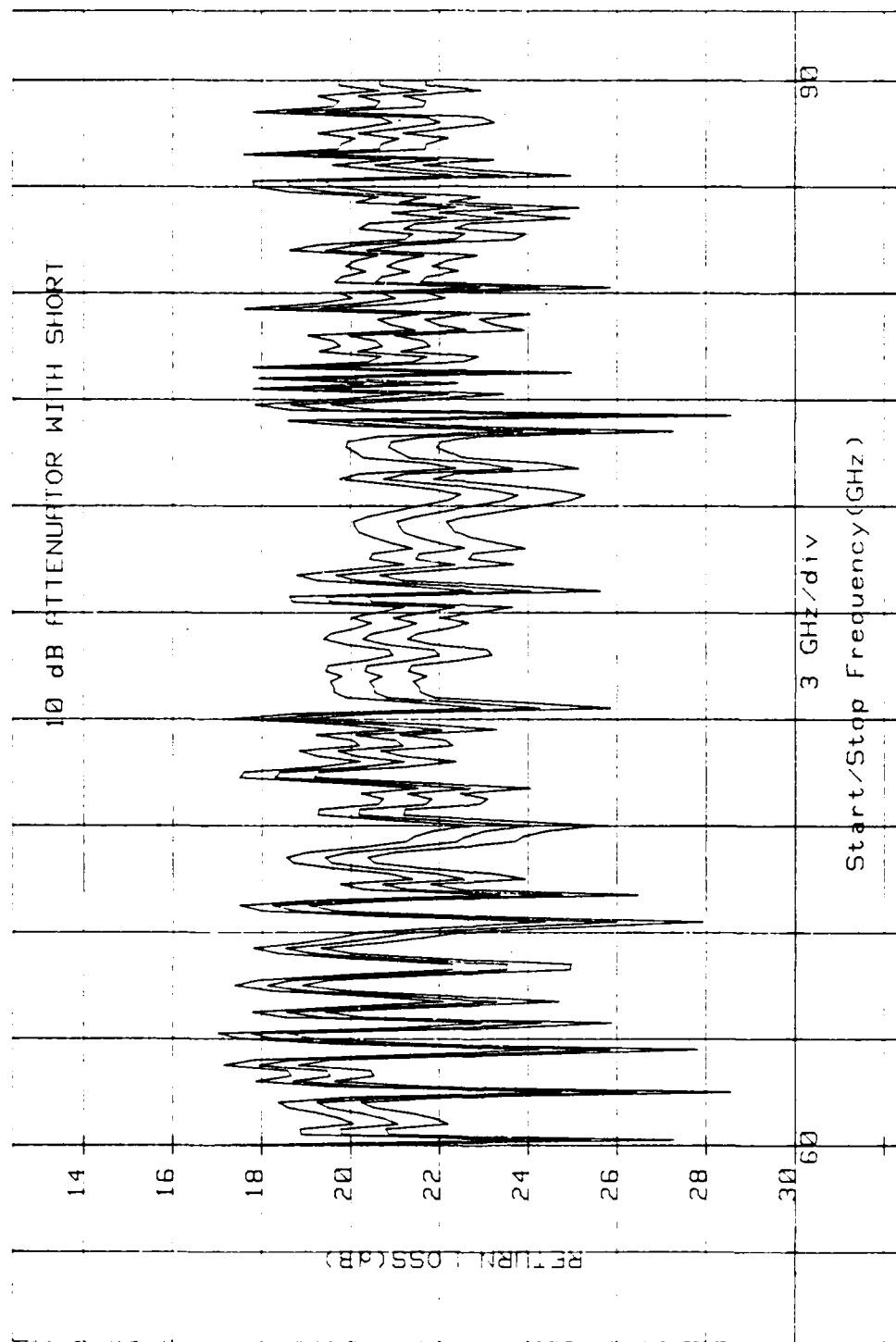

Figure 15. Return Loss for 10 dB Attenuator With Shorted Output Using Schottky Diode Detector.

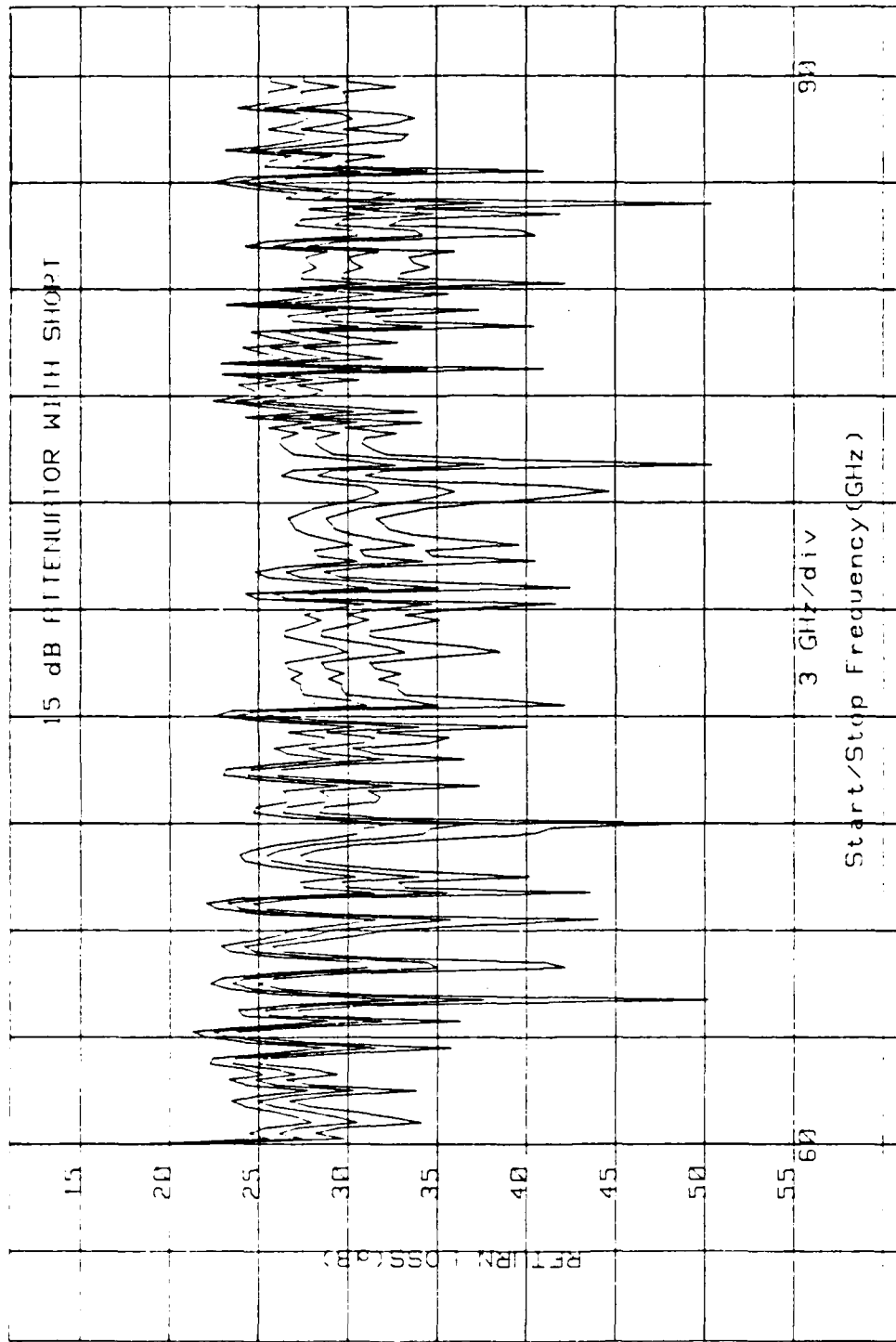

Figure 16. Return Loss for 15 dB Attenuator With Shorted Output Using Schottky Diode Detector.

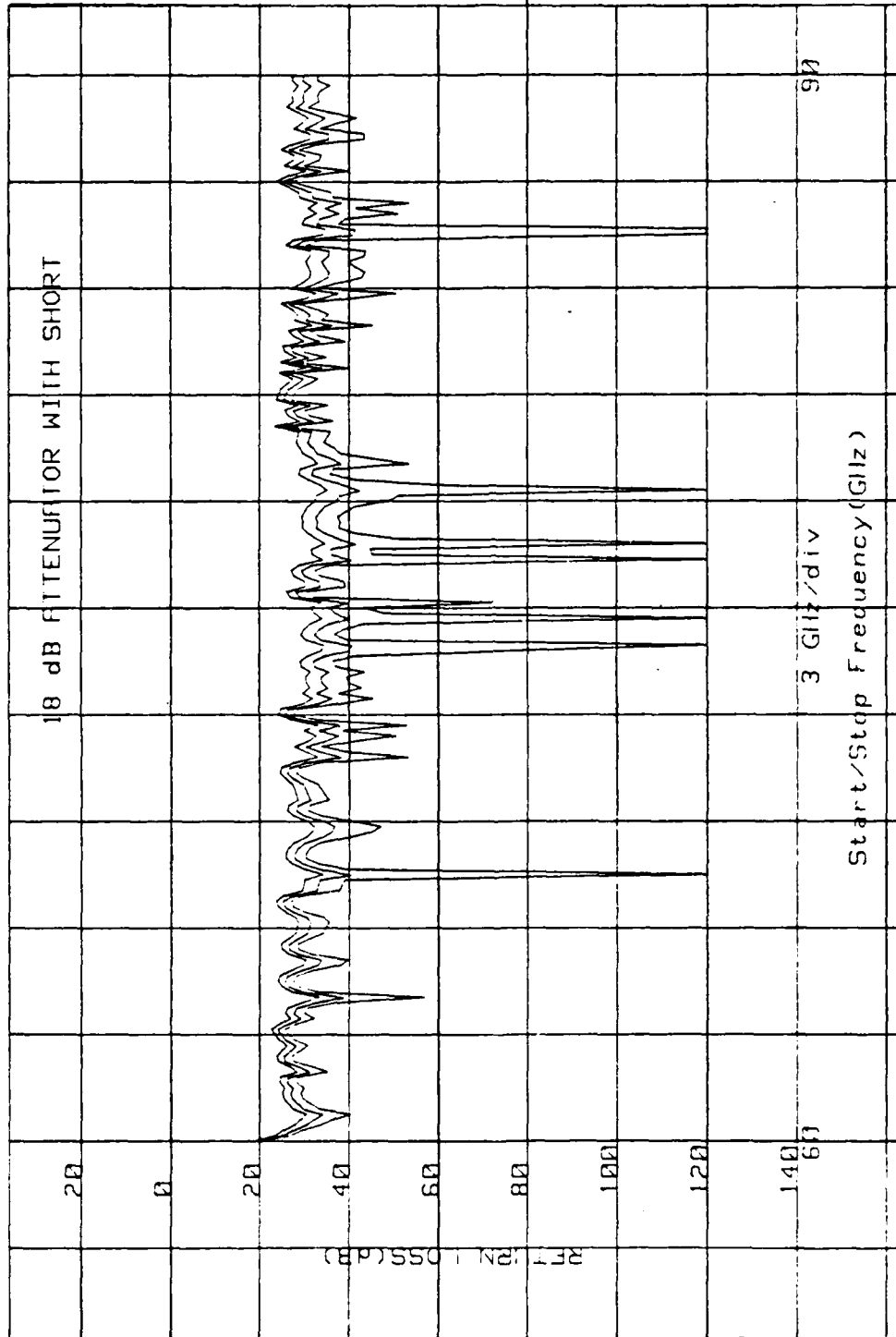

Figure 17. Return Loss for 18 dB Attenuator With Shorted Output Using Schottky Diode Detector.

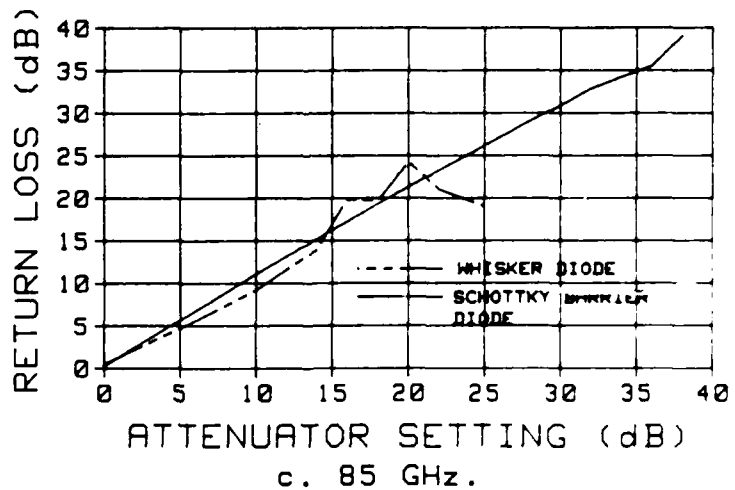
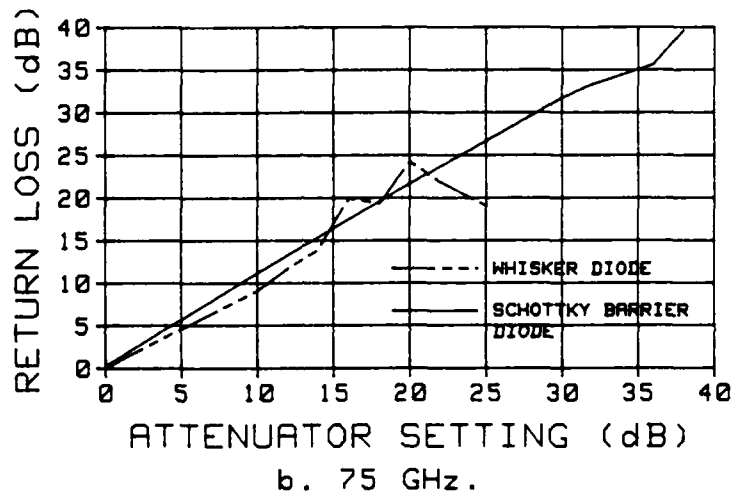
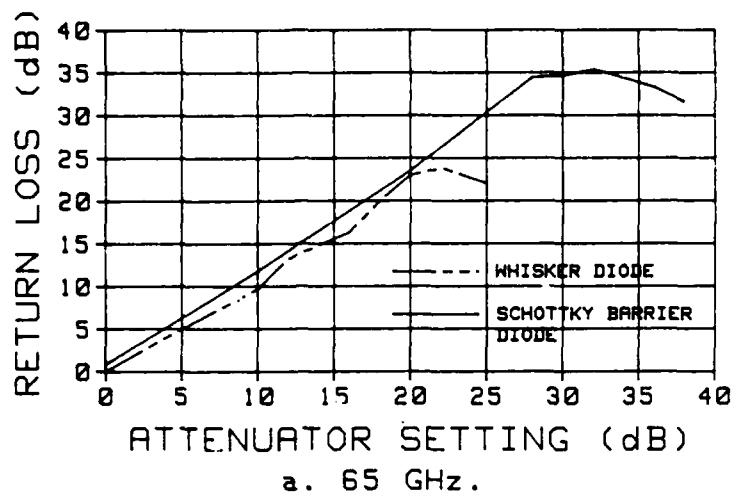

Figure 18. Dynamic Range for Return Loss.

output. Readings on the waveform peak-to-peak voltage and the DC level were taken at 60 GHz, 75 GHz and 90 GHz. The results are contained in Table VIII. Additionally, graphs of the RMS output voltage vs. input power are illustrated in Figure 19.

TABLE VIII

DIODE DETECTOR VOLTAGE LEVELS

Diode Detector	Peak-to-Peak Voltage			DC Level		
	60 GHz	75 GHz	90 GHz	60 GHz	75 GHz	90 GHz
Whisker No. 1	2.0mV	2.5mV	1.5mV	3.0mV	2.8mV	2.0mV
Whisker No. 2	2.0mV	3.0mV	2.5mV	-2.0mV	-1.0mV	-0.5mV
Schottky	1.2mV	1.8mV	2.0mV	55.0mV	42.0mV	32.0mV

The peak-to-peak voltage of the waveforms did not vary a great deal but the DC level was substantially higher for the Schottky barrier diode. As a result, the output voltages for the Schottky diode detector in Figure 19 were consistently higher across the band. This may be one reason the Schottky detector had a greater dynamic range.

4. Comparisons With Previous Theses Results

This improved system could only be considered as viable if devices which were measured in previous theses as well as devices offered by manufacturers were measured by the new system and the results compared. In previous Naval Postgraduate School theses a number of devices were tested

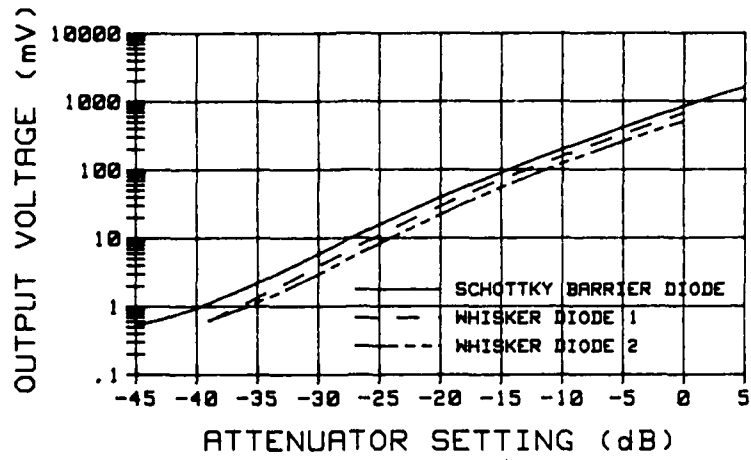

a. 65 GHz.

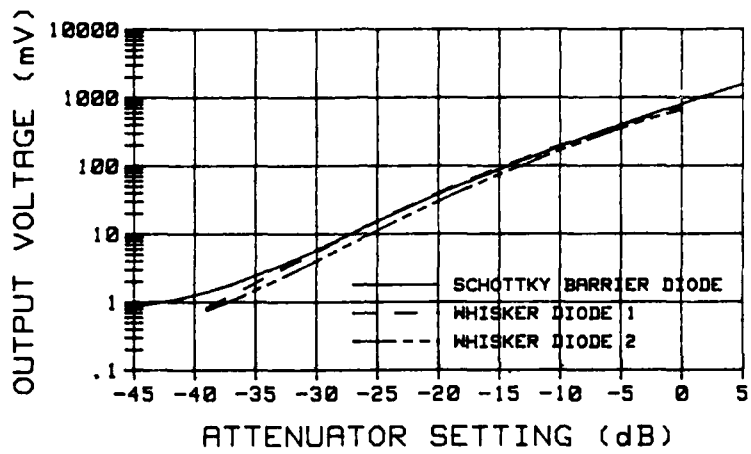

b. 75 GHz.

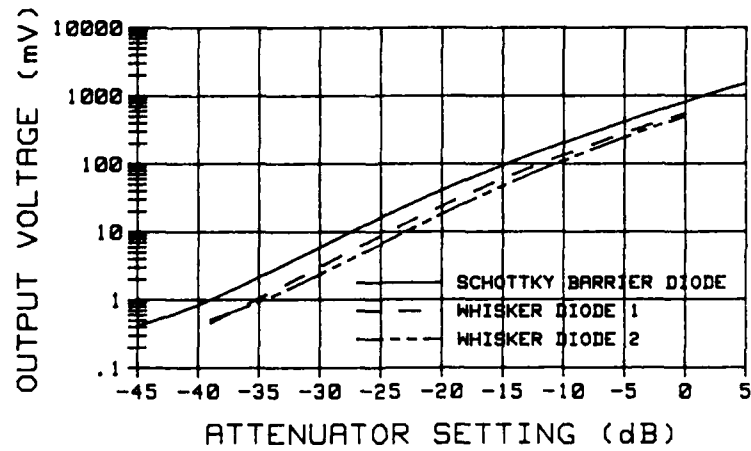

c. 85 GHz.

Figure 19. Diode Detector Output Voltage Comparison.

for return loss to determine the performance of the old system (Refs. 1,4). The same devices were tested with the new system and the graphical results compared.

a. Fixed Short From 60-70 GHz and 70-80 GHz

In Figures 20 and 21 a comparison of fixed short return losses from 60-70 GHz and 70-80 GHz respectively are shown. Aside from a pattern difference caused by a phase difference between the two measurements, the average value and variation of both the measurement (center line) and the uncertainties (outer line) are virtually the same. Both systems appear to perform equally for this device.

b. Tunable Load from 70-80 GHz

The return losses for a tunable load at mid-band are compared in Figure 22. Although the original thesis did not specify the setting of the load (Ref. 1:pp. 37-38), the tunable load for the improved system was a Hughes 45665 Tunable Load set at 2.00 (maximum setting was 5.00). Hughes specification for the tunable load VSWR is 1.05:1 nominal or 32 dB of return loss (Ref. 2:p. 112).

c. Detector Mount from 70-80 GHz

A comparison of the return loss for a detector mount from 70-80 GHz is contained in Figure 23. The previous test (Figure 23a) indicates an increase of return loss at about 75.5 GHz while the recent test (Figure 23b) indicates a relatively flat response from 70-80 GHz. One would hope that a detector mount would offer a uniform

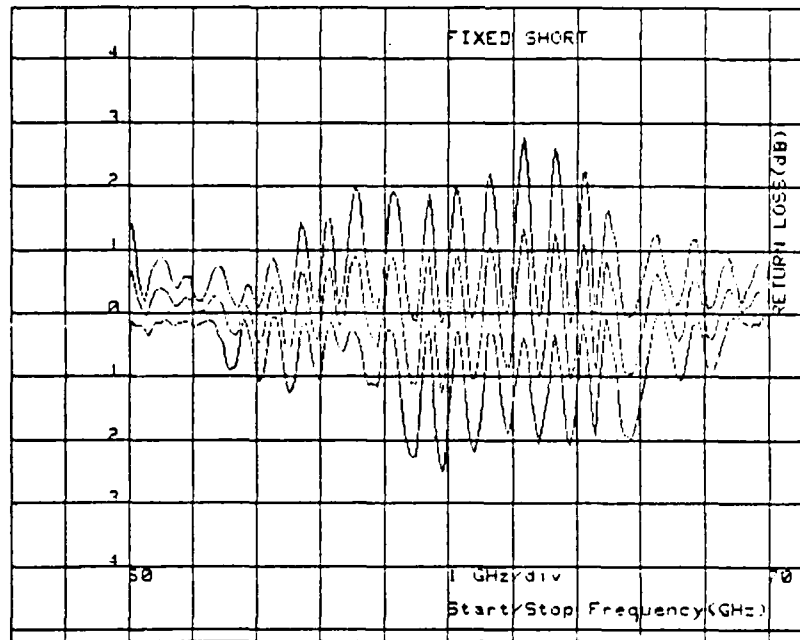

a. Old System.

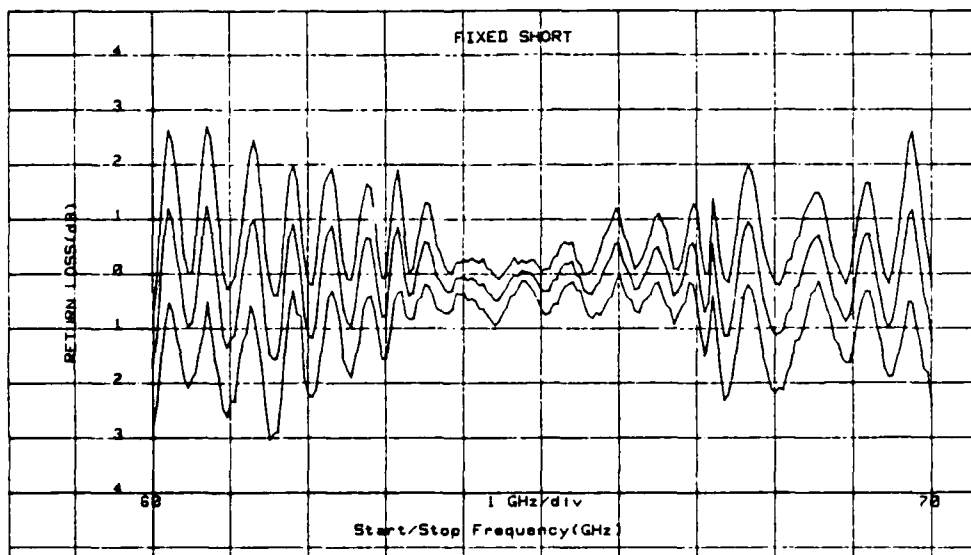

b. Improved System.

Figure 20. Fixed Short Return Loss Comparison from 60-70 GHz.

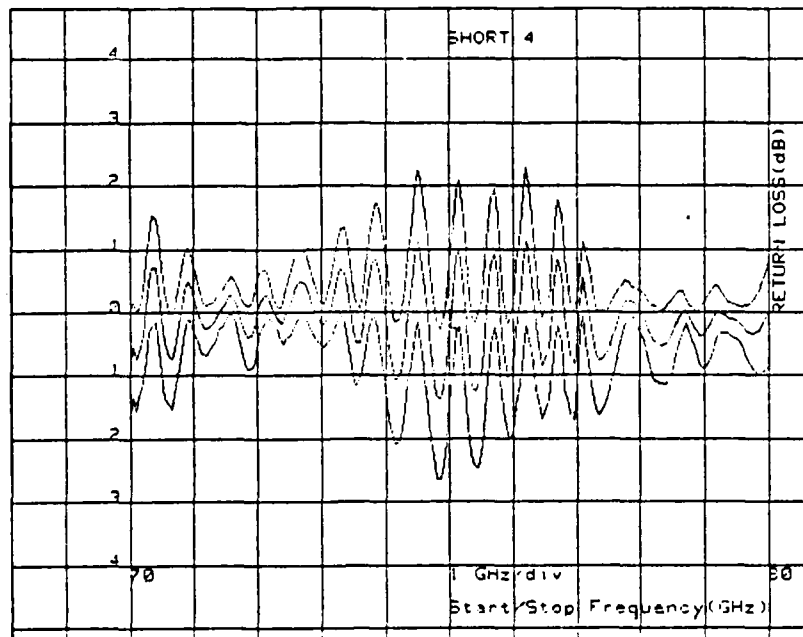

a. Old System.

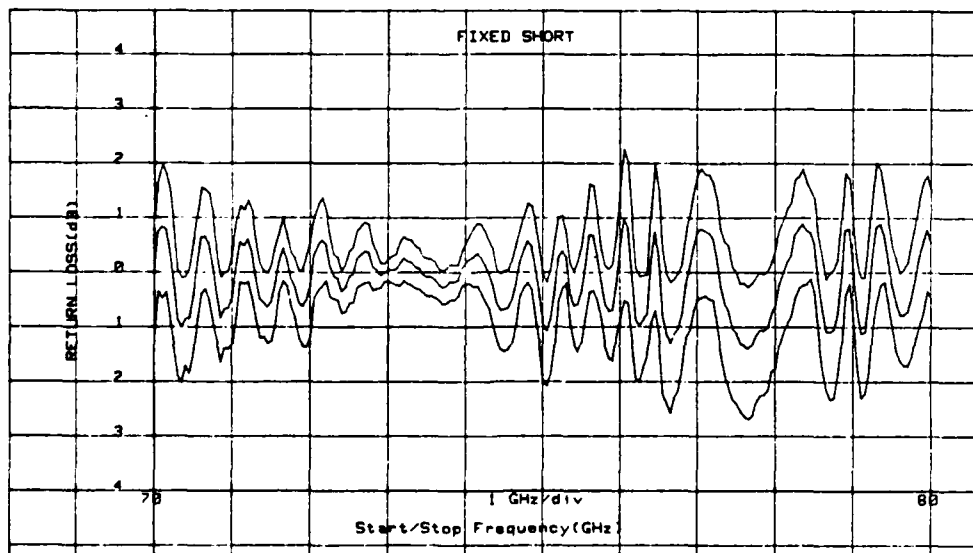

b. Improved System.

Figure 21. Fixed Short Return Loss Comparison from 70-80 GHz.

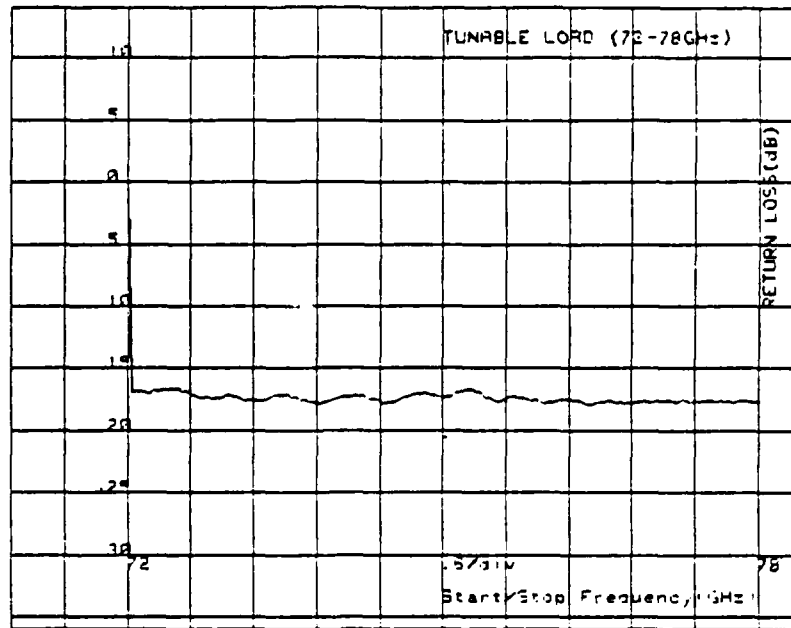

a. Old System.

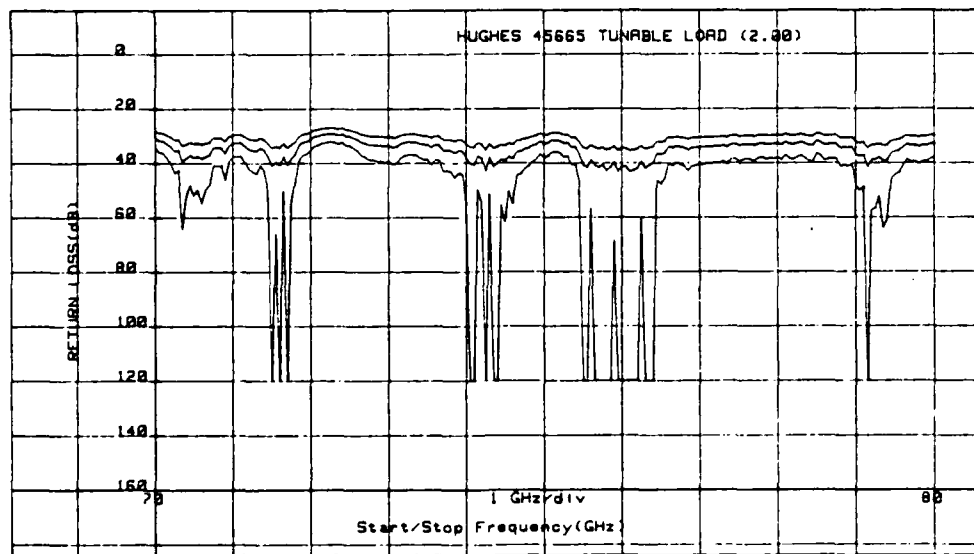

b. Improved System.

Figure 22. Tunable Load Return Loss Comparison from 70-80 GHz.

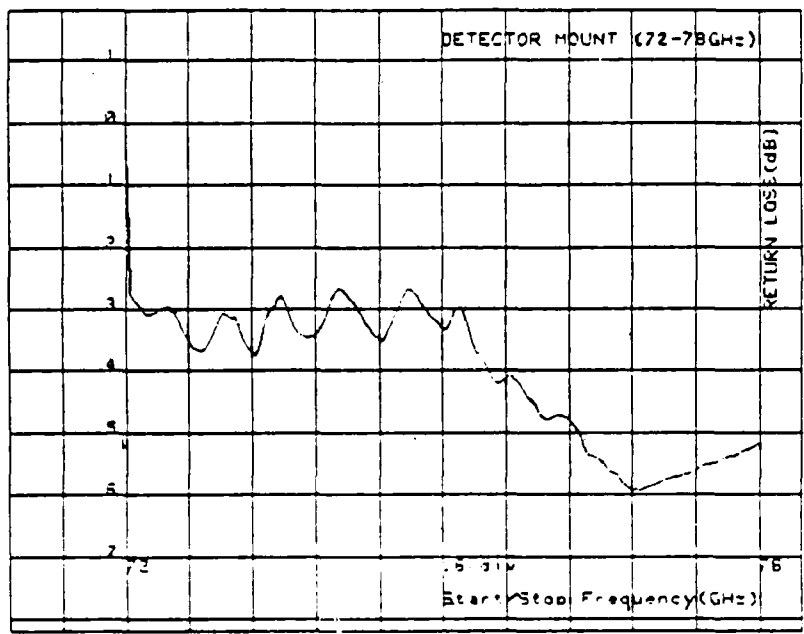

a. Old System.

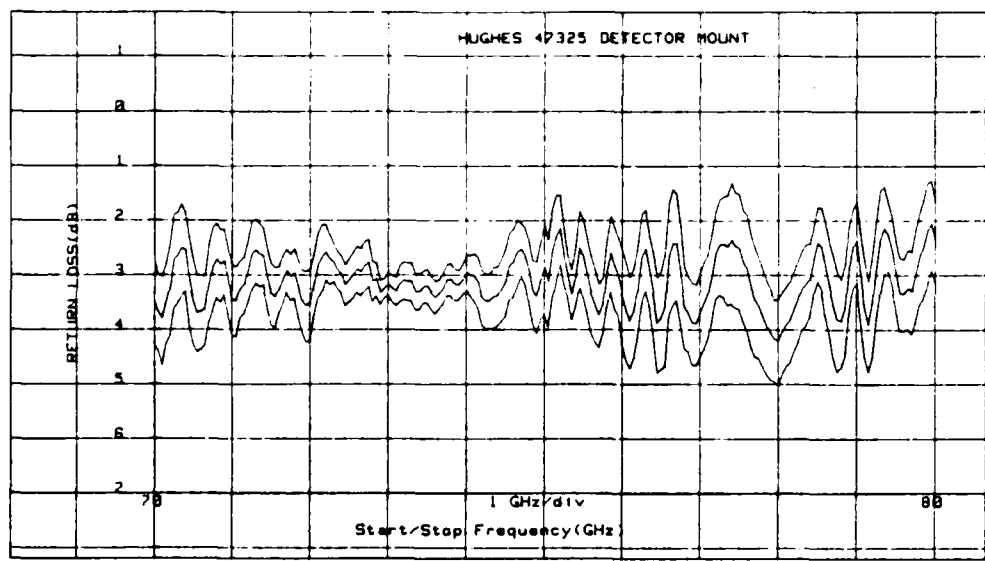

b. Improved System.

Figure 23. Detector Mount Return Loss Comparison from 78-80 GHz.

response to an input especially at mid-band. This detector, the Hughes 4732xH series, did not have a specified VSWR but flatness was specified as ± 1.5 dB max (Ref. 2:p. 90). The comparison in Figure 23 is not conclusive but the improved system is showing a response which seems to be more reasonable for this type of device.

5. Comparison With Manufactured Device

The final comparison of return loss was made using a Baytron Horn Antenna (Part No. 7E-67/25). The rated return loss for this antenna is advertised at 1.2 VSWR or 20.7 dB (Ref. 5:p. 14). Figure 24 shows the return loss for the antenna at mid-band, 70-80 GHz. The return loss is well above the 20.7 dB rating which indicates that both the antenna and the Millimeter-Wave Scalar Network Analyzer work as advertised.

B. INSERTION LOSS MEASUREMENTS

The insertion loss measurements made with the Millimeter-Wave Scalar Network Analyzer followed much the same pattern as the return loss measurements. This section first discusses the calibration of the system for insertion loss. The results using the calibrated variable attenuator to determine the accuracy and range of the insertion losses are then discussed with graphical and tabular results given. A comparison of performance between the whisker and Schottky diodes is also given. The section finishes up with a

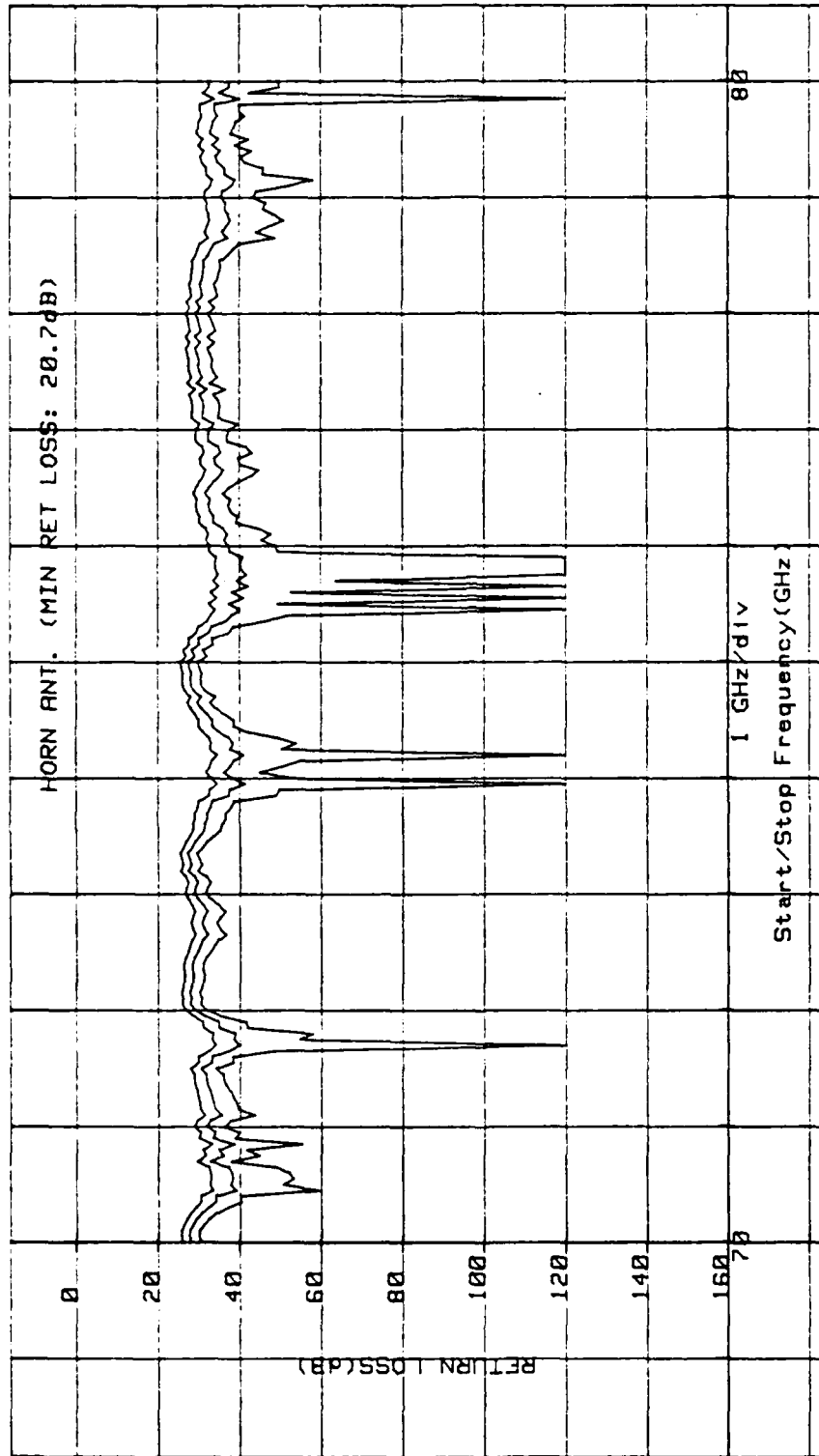

Figure 24. Return Loss for Horn Antenna from 70-80 GHz.

comparison of several devices which were tested in previous theses. Only graphical results are given for these comparisons.

1. Calibration

As discussed in the Background Information, the system must be calibrated with no DUT to determine a baseline for measurements. First, the return loss calibration is performed to determine $|S_{22}|$. Next, the system must be calibrated with the B-coupler installed. Referring to Figure 4, if the A-coupler is used, then the A and B couplers are placed together to form a through section of zero length. If the A-coupler is removed, then the B-coupler is placed directly on the isolator at the output of the R-coupler for this measurement. Once this is performed, DUT measurement can begin.

2. Insertion Loss Accuracy

The whisker diode detectors were used first to allow the A-coupler to remain installed for the measurement as illustrated in Figure 2b. Insertion losses for 0 dB, 10 dB, 20 dB and 25 dB settings on a variable attenuator are shown in Figures 25, 26, 27 and 28 respectively. Once again the maximum measured insertion loss was only about 20 dB.

As with the return loss, the whisker diode detectors were thought to be the problem with the range. Only one Schottky diode was available and replacement of either the A detector or the B detector did not improve the performance

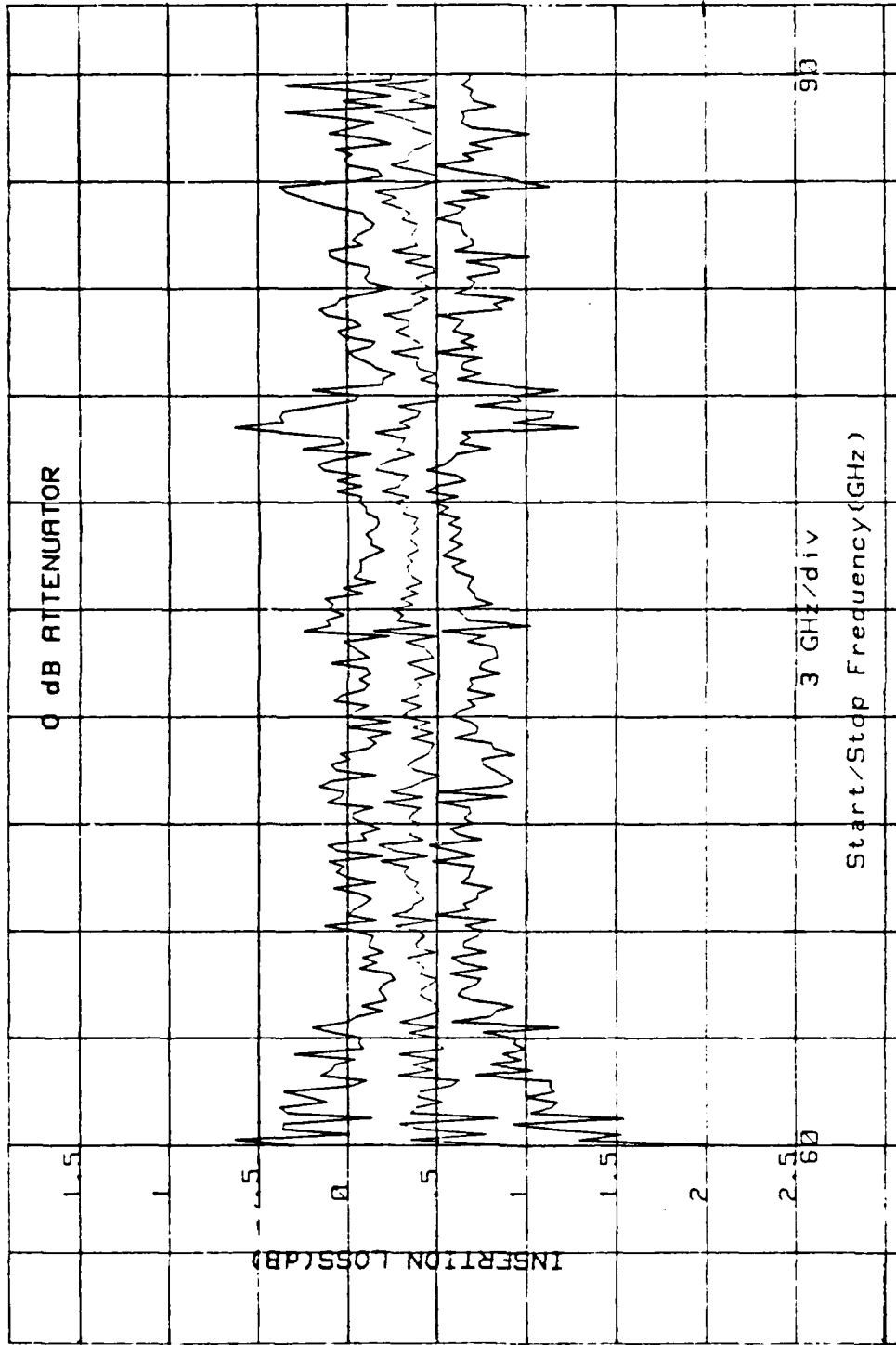

Figure 25. Insertion Loss for 0 dB Attenuator Using Whisker Diode Detector.

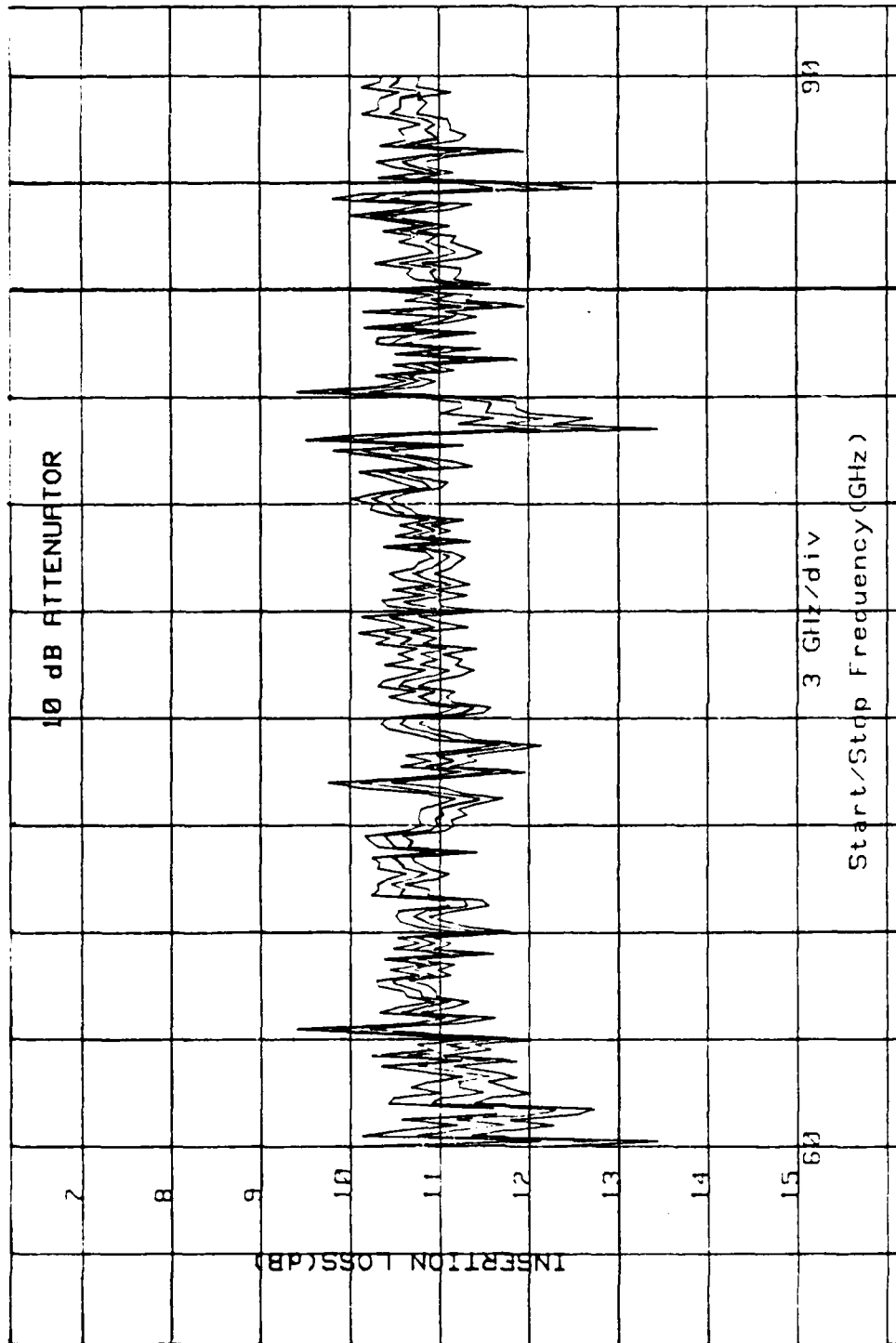

Figure 26. Insertion Loss for 10 dB Attenuator Using Whisker Diode Detector.

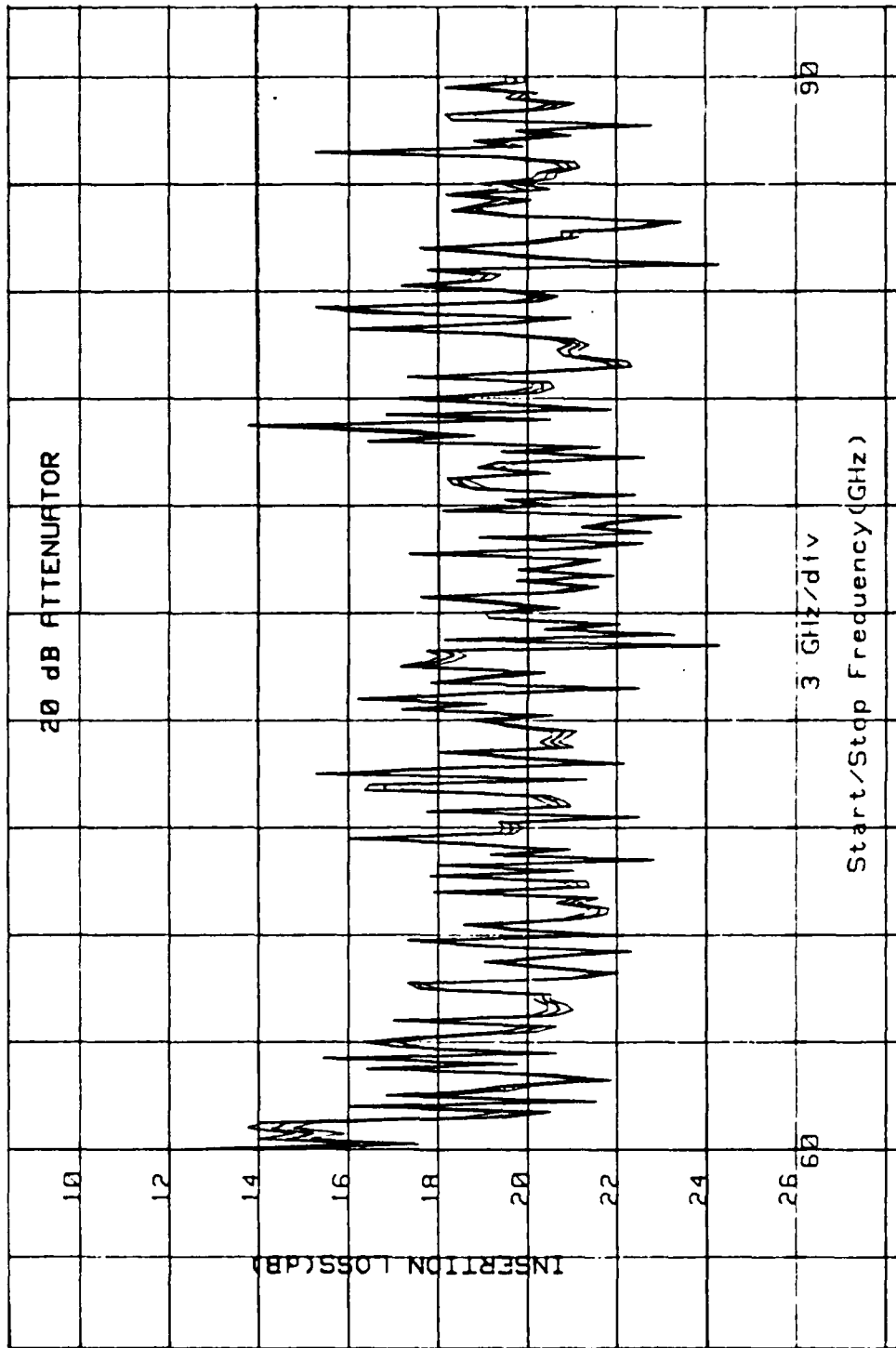

Figure 27. Insertion Loss for 20 dB Attenuator Using Whisker Diode Detector.

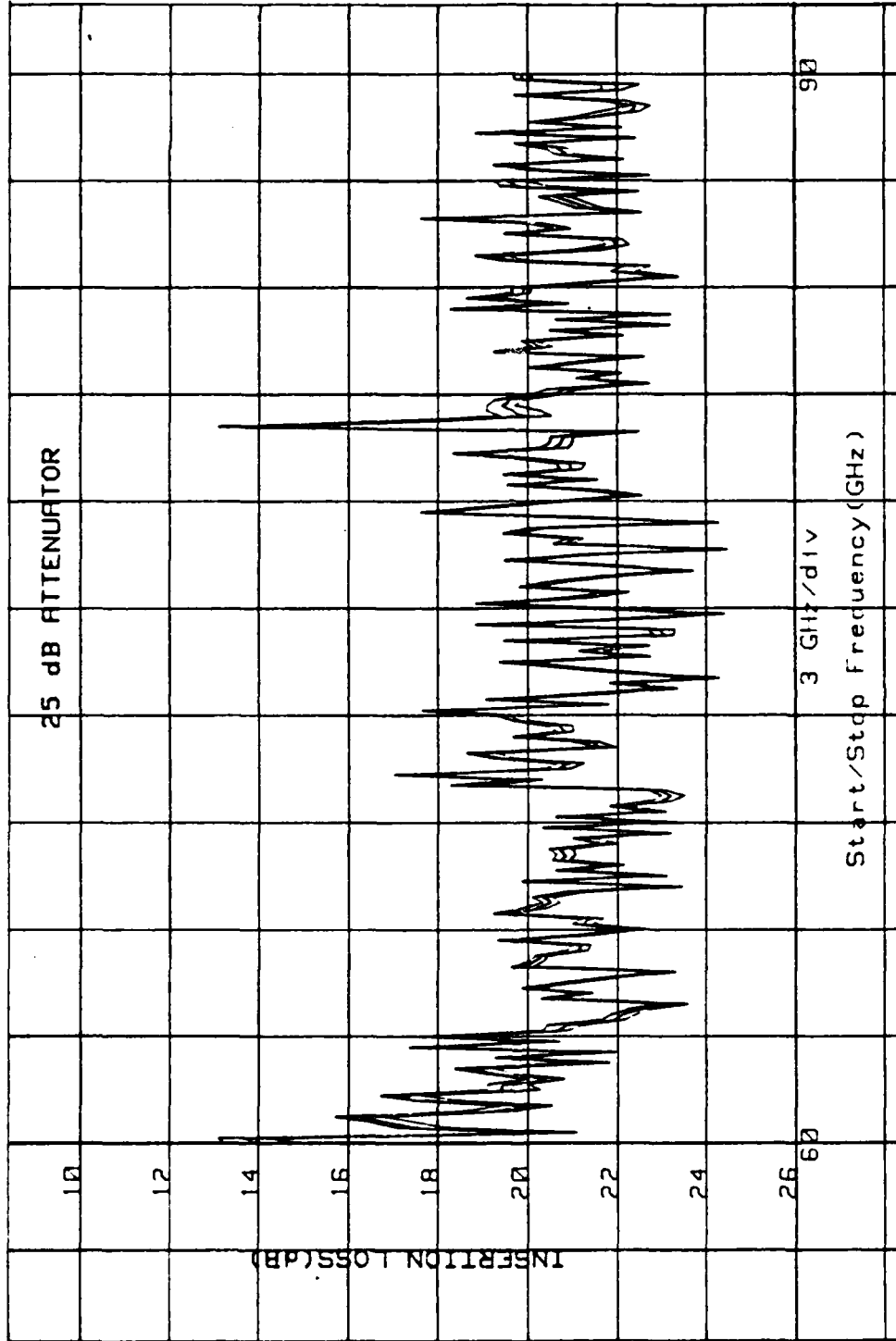

Figure 28. Insertion Loss for 25 dB Attenuator Using Whisker Diode Detector.

of the system. The solution, therefore, consisted of replacing the B detector and performing the insertion loss measurements without the A-coupler in the system.

Using this method insertion loss measurements for 0db, 10 dB, 20 dB, 30 dB, 40 dB and 45 dB were performed with the Schottky diode detector and the results given in Figures 29, 30, 31, 32, 33 and 34 respectively. Tabular results are found in Appendix C, Tables IX, X, XI, XII, XIII, and XIV. Once again the superior performance of the Schottky diode detector substantially increased the dynamic range although the accuracy did not seem as good. Figures 33 and 34 show a noise floor of about 40 dB which is double that of the whisker diode detector.

A phenomenon which appeared in the insertion loss measurements with the Schottky diode detector was a jump in insertion loss at the band-switch frequencies, 70 GHz and 80 GHz. At the band-switch frequencies the Sweep Oscillator Millimeter-Wave Plug-in commands the Full Band Sweep Source to select the next band rf source (See Figure 4). The Schottky diode detector would seem the likely candidate as the source of this discontinuity since the other detectors did not have this problem. Aside from the higher DC level of its output, however, the Schottky detector exhibits a square-law behavior with no indication that it changes

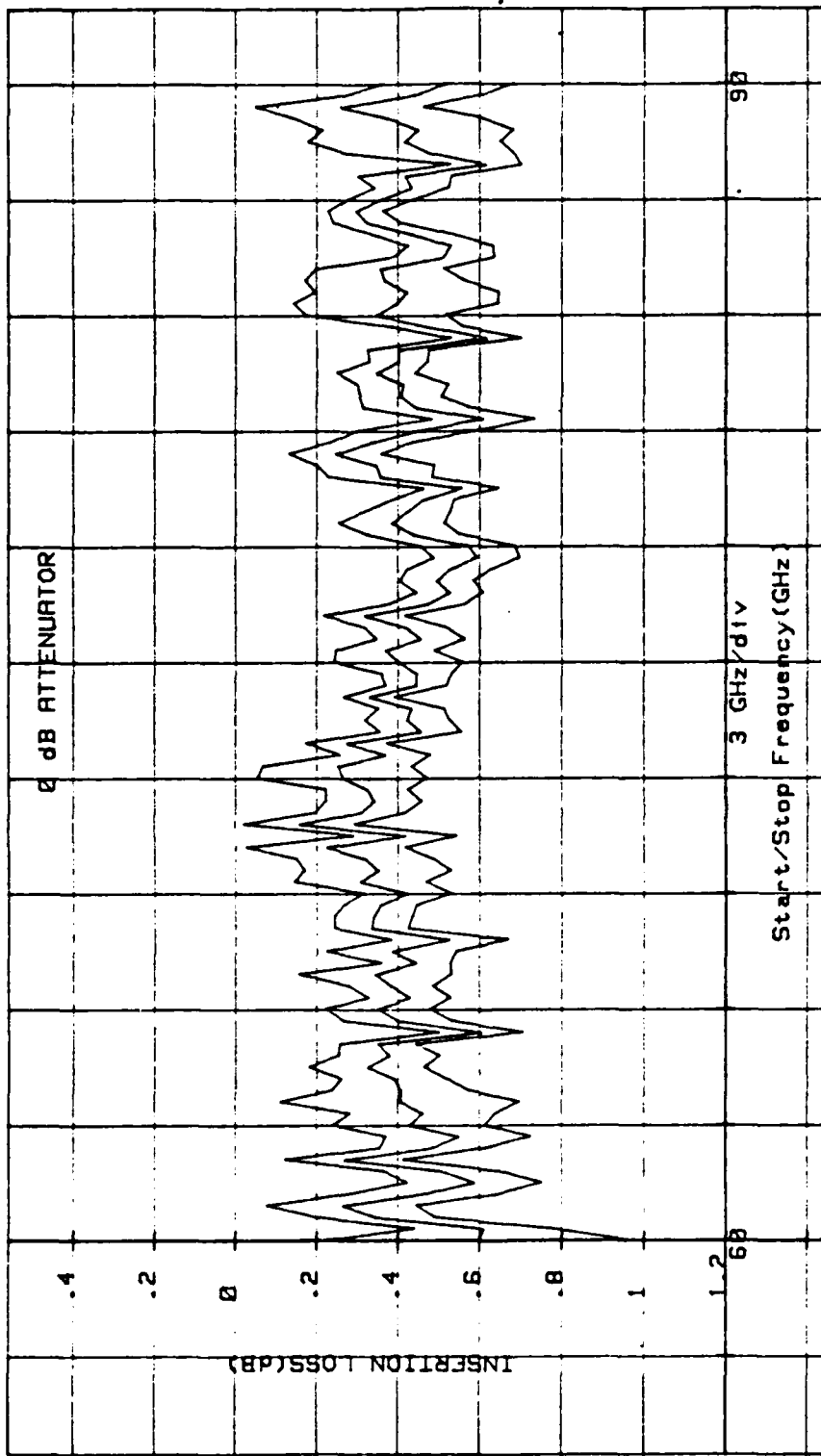

Figure 29. Insertion Loss for 0 dB Attenuator Using Schottky Diode Detector.

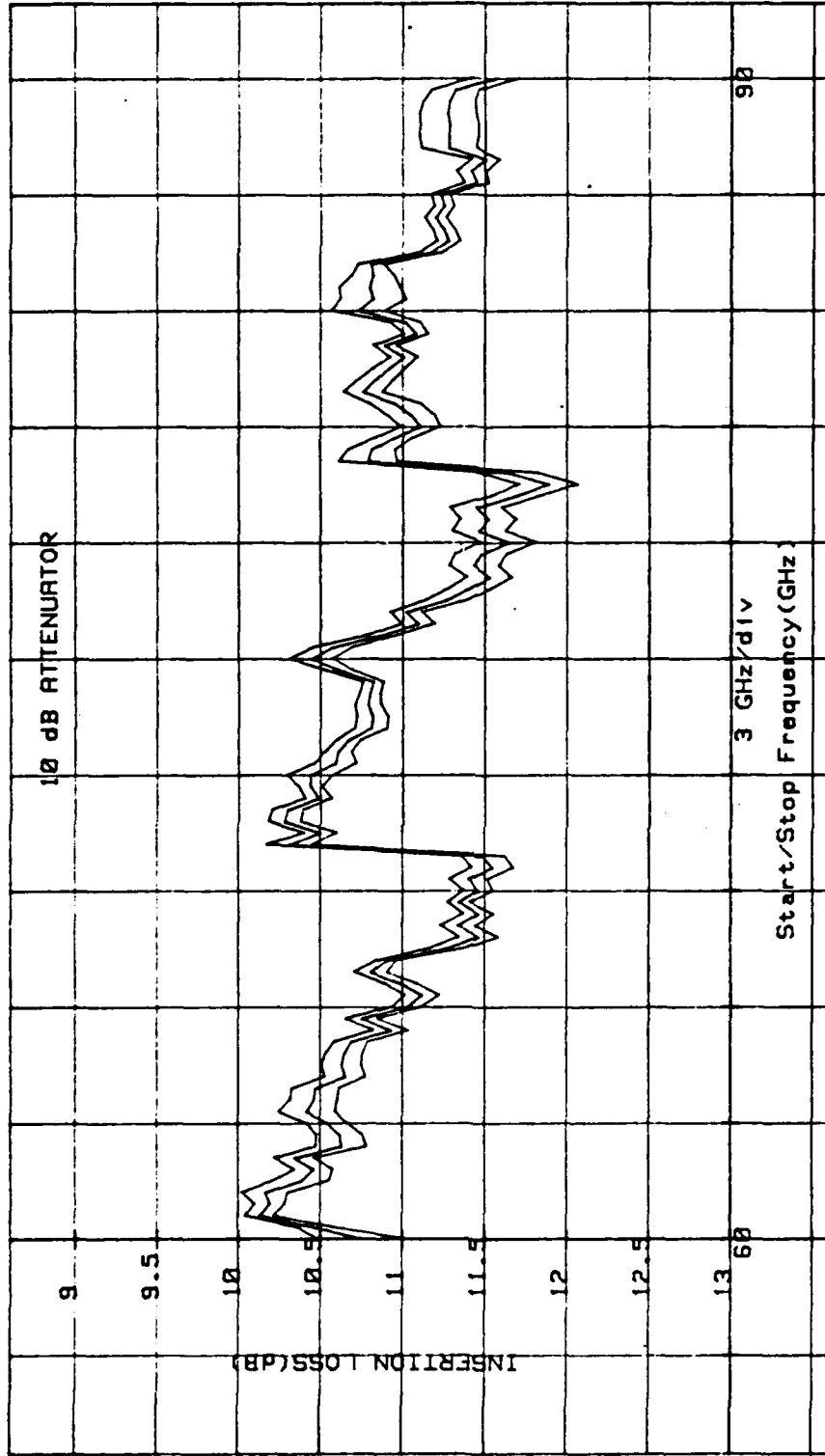

Figure 30. Insertion Loss for 10 dB Attenuator Using Schottky Diode Detector.

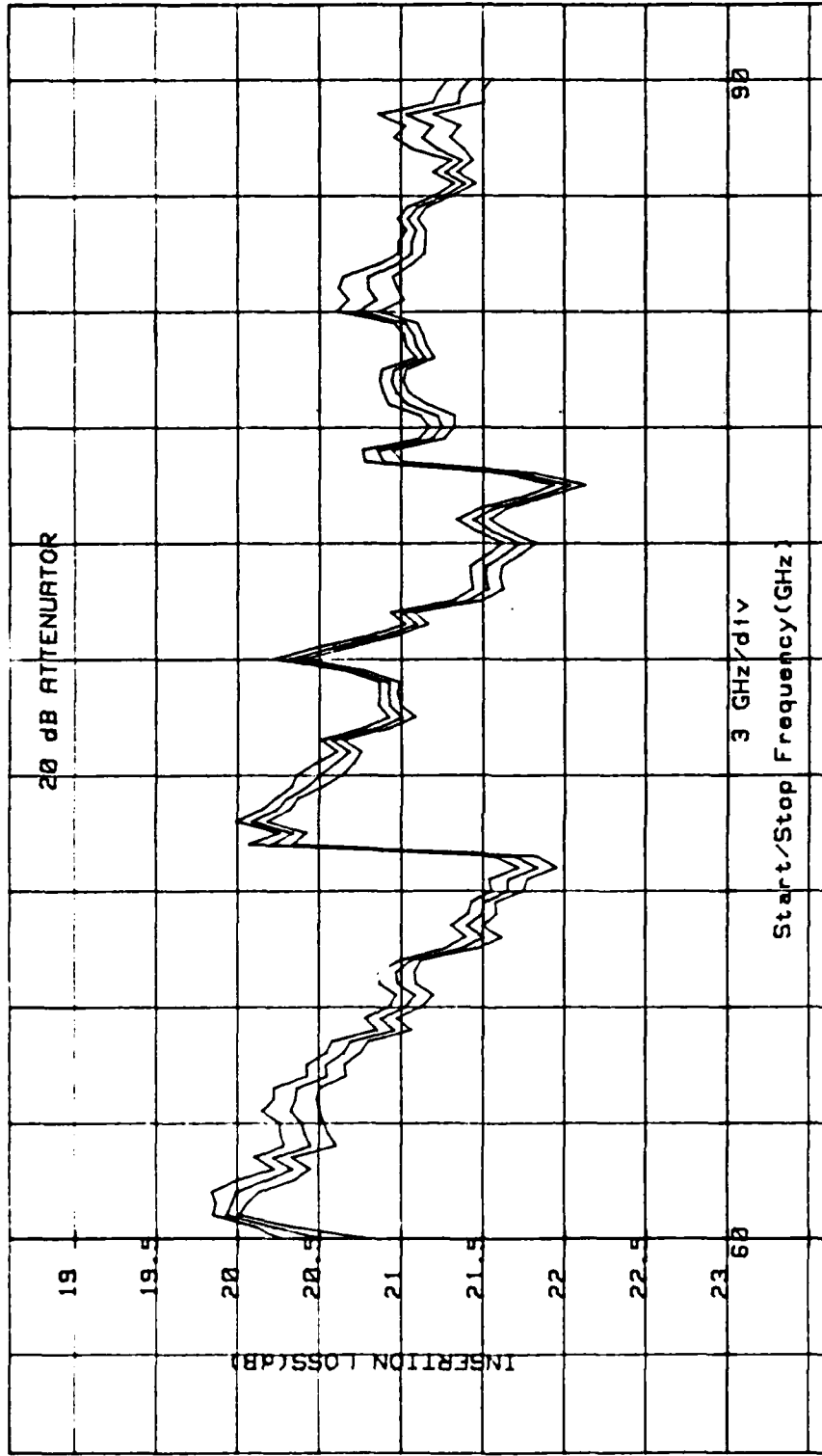

Figure 31. Insertion Loss for 20 dB Attenuator Using Schottky Diode Detector.

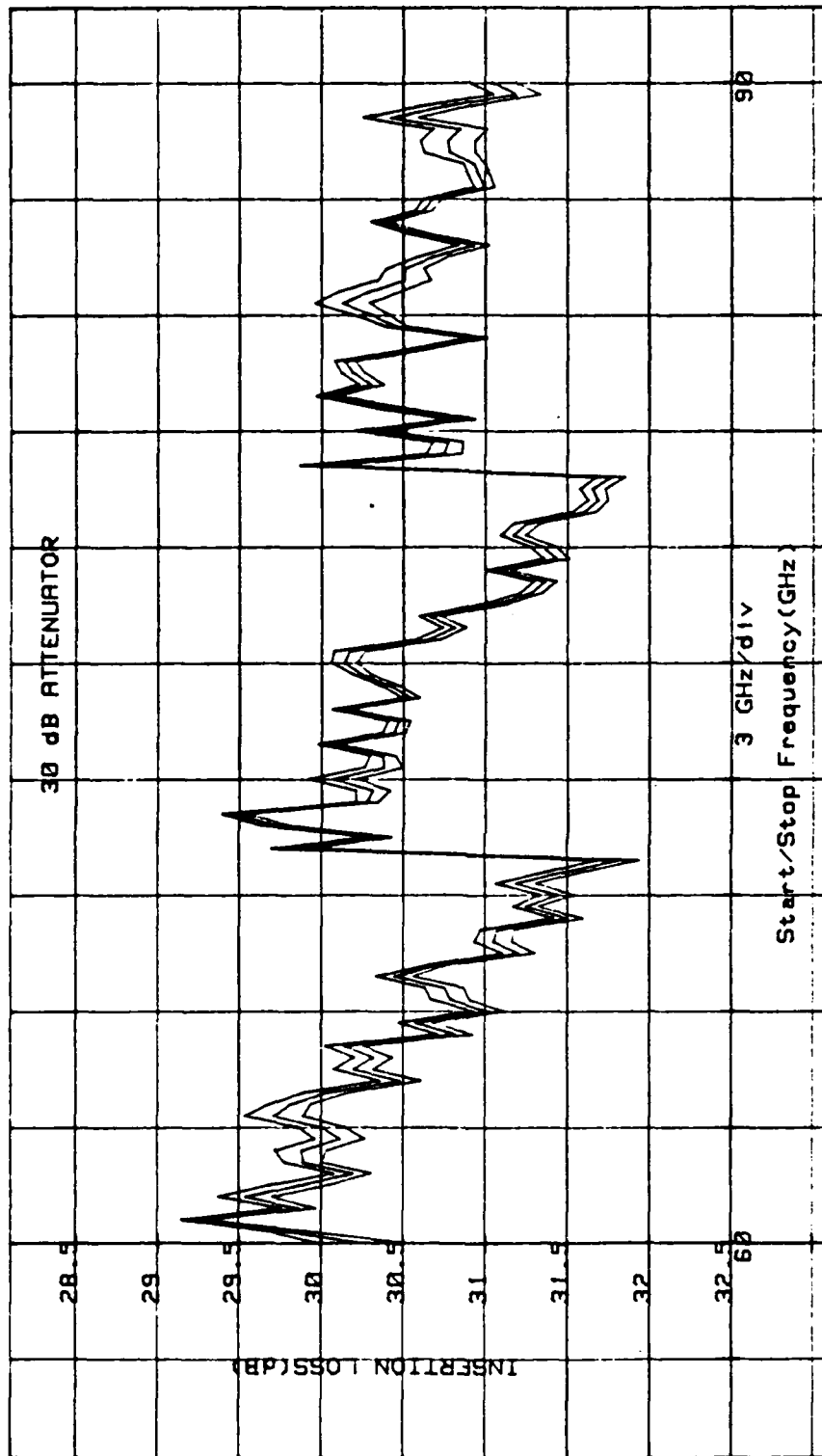

Figure 32. Insertion Loss for 30 dB Attenuator Using Schottky Diode Detector.

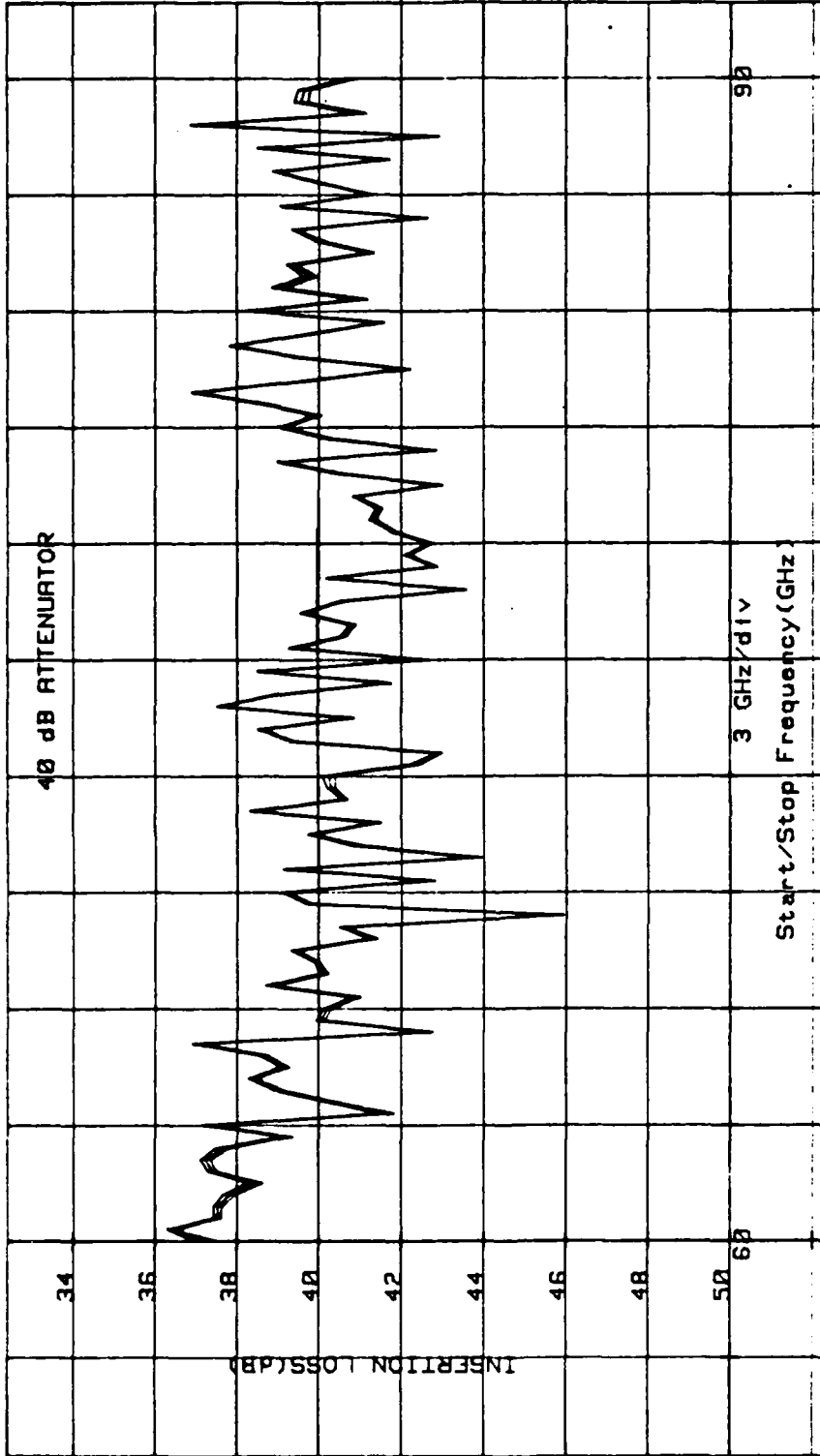

Figure 33. Insertion Loss for 40 dB Attenuator Using Schottky Diode Detector.

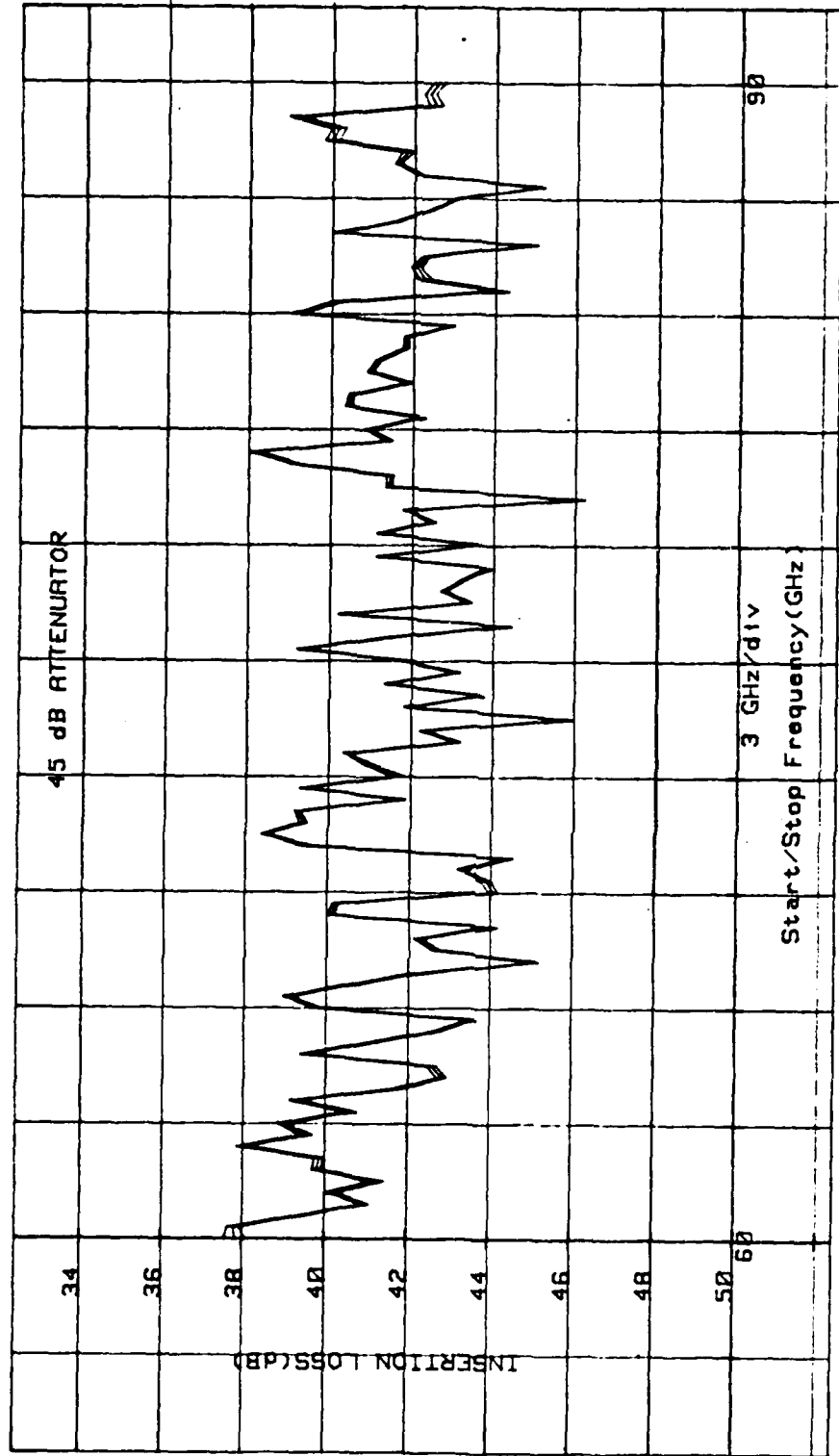

Figure 34. Insertion Loss for 45 dB Attenuator Using Schottky Diode Detector.

markedly at the band-switch points. It is unclear, therefore, what is causing the jumps in insertion loss at these points.

3. Dynamic Range

A graphical comparison of the dynamic range between the whisker diode detectors and the Schottky diode detectors is given in Figure 35. The performance of the Schottky diode detector is clearly better than that of the whisker diode and the system performance is comparable with that advertised by Hughes Aircraft Company [Ref. 2:pp. 24-25].

4. Comparison With Previous Theses Results

Previous theses measured a variety of devices and comparison of the old and improved systems provided excellent results. The first set of comparisons are from a thesis by George S. Leoussis, LT, Greek Navy [Ref. 1:pp. 37-38, 47-51]. It should be noted that the manufacturer of the devices measured by Leoussis were not specifically identified.

a. 10 dB Attenuator from 70 to 80 GHz

The comparison of insertion loss measurement for the old and improved systems are illustrated in Figure 36. Considering the expanded scale for the improved system measurement, the two measurements agree very well. It is interesting to note that in neither case was the measurement within the ± 0.1 dB tolerance given by the manufacturer for the calibrated variable attenuator [Ref. 2:p. 35].

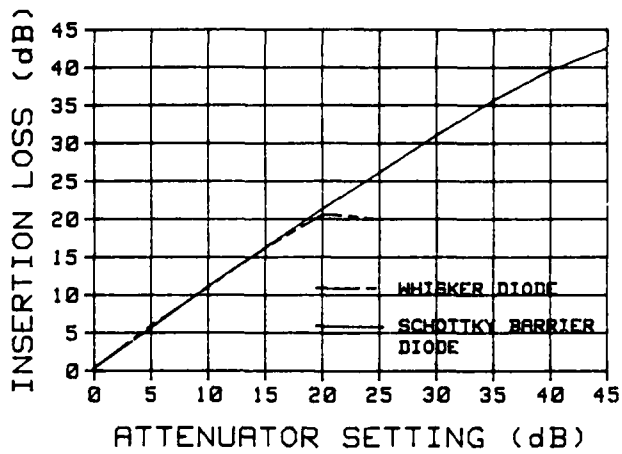

a. 65 GHz.

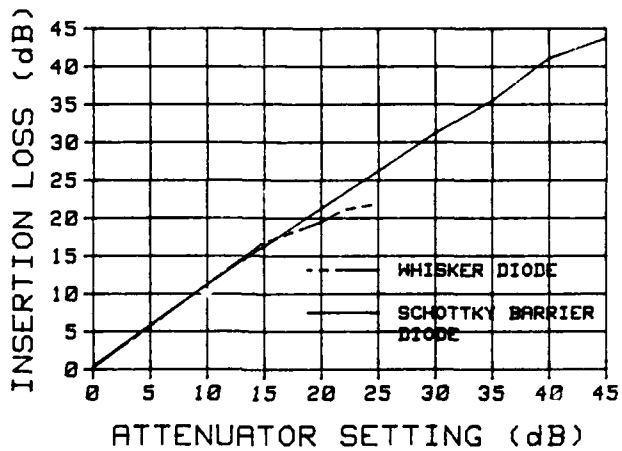

b. 75 GHz.

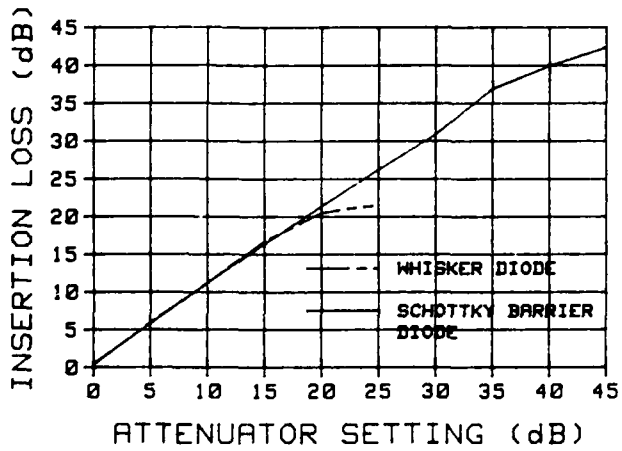

c. 85 GHz.

Figure 35. Dynamic Range for Insertion Loss.

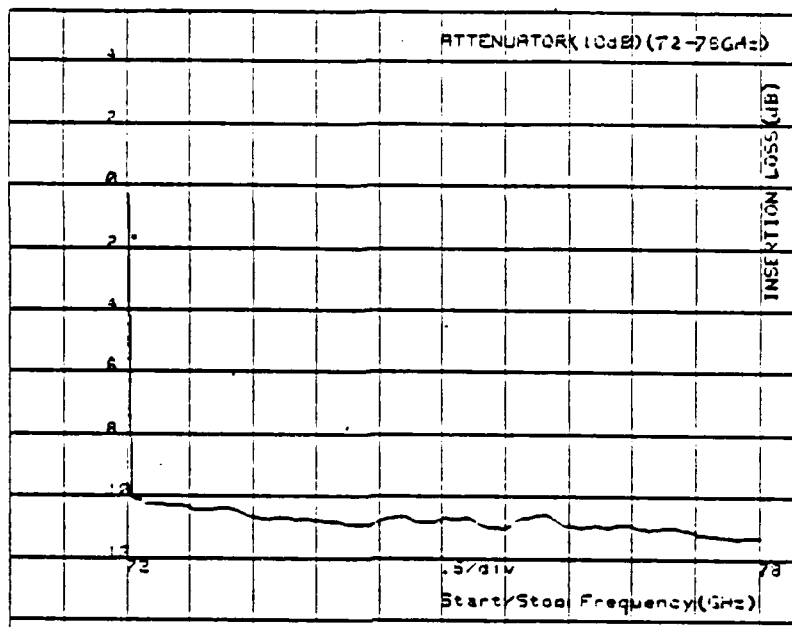

a. Old System.

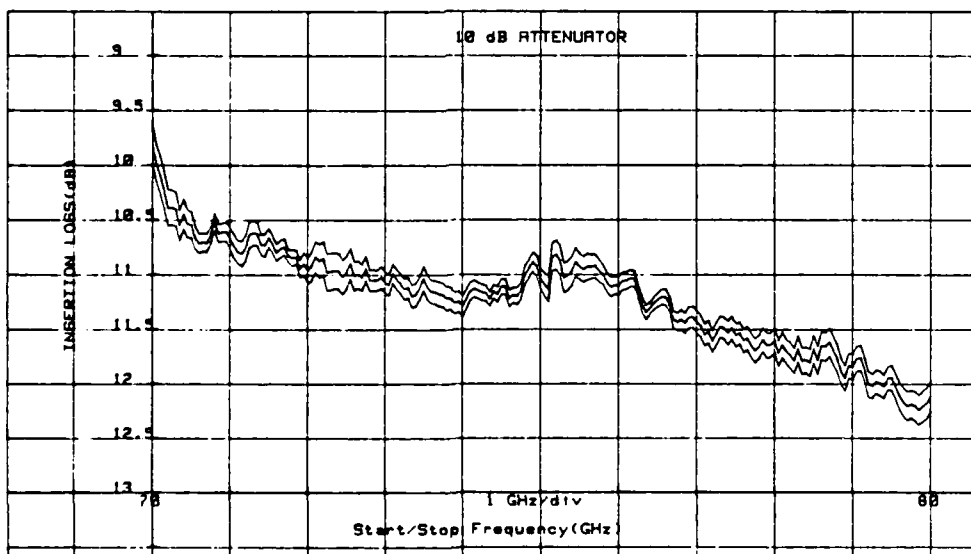

b. Improved System.

Figure 36. 10 dB Attenuator Insertion Loss Comparison from 70-80 GHz.

b. 20 dB Attenuator from 70 to 80 GHz

From Figure 37 one can see that the two systems are in close agreement again. Although the improved system appears to be a little closer to the set attenuation, once again neither measurement falls within the tolerance.

c. 30 dB Attenuator from 70 to 80 GHz

Comparison of the two systems remains consistent in Figure 38. The improved system appears closer to the attenuator tolerance but is still outside the range.

d. 40 dB Attenuator from 70 to 80 GHz

In Figure 39a the old system has encountered the maximum limit of its dynamic range at about 36 dB while the improved system is hovering around the set attenuation of 40 dB. The size of the excursions in Figure 39b indicate that the system was approaching its limit but there is no doubt that the improved system has a better performance at this level.

e. 10 dB Directional Coupler from 70 to 80 GHz

The correlation between the two systems in Figure 40 appears very close indicating that the two systems obtained the same insertion loss for this device.

The next set of comparisons is from a thesis by Elia Demetrios Gatsos, LT, Greek Navy [Ref. 4:pp. 34, 53-60].

f. Through Section from 60 to 90 GHz

It was unclear from the thesis by Gatsos what the through section consisted of. From Figure 41a it would

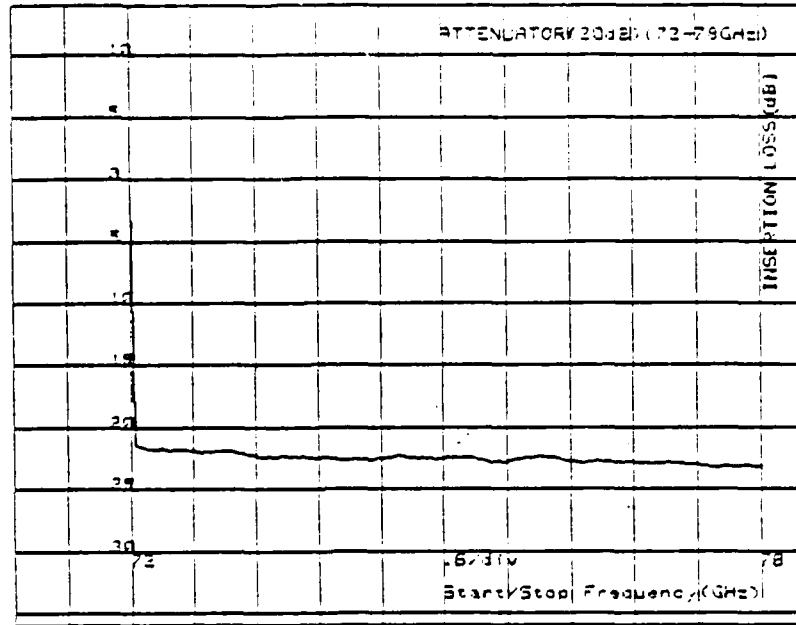

a. Old System.

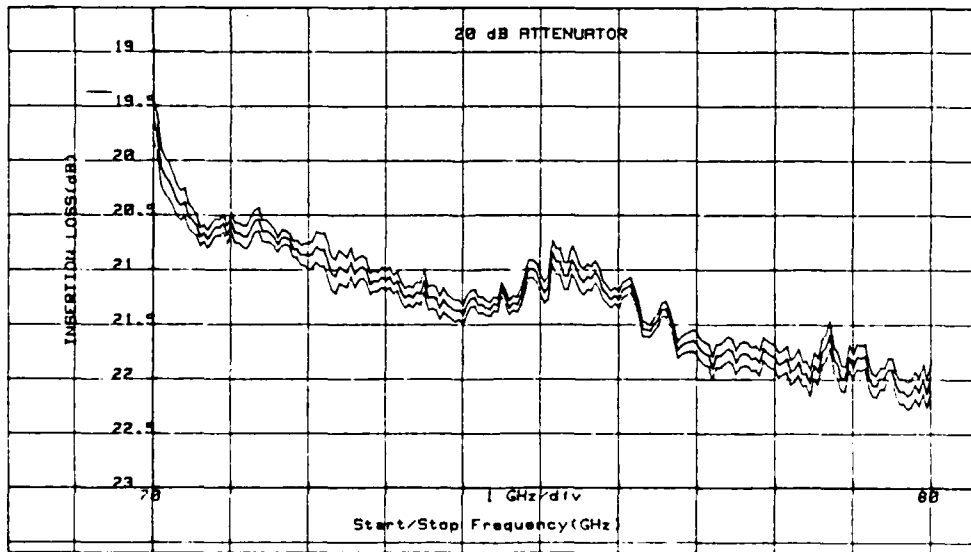

b. Improved System.

Figure 37. 20 dB Attenuator Insertion Loss Comparison from 70-80 GHz.

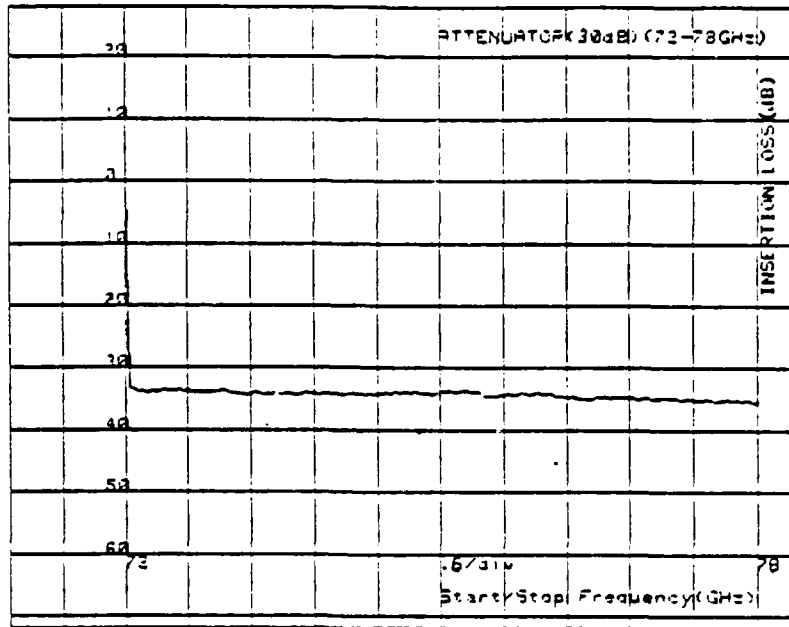

a. Old System.

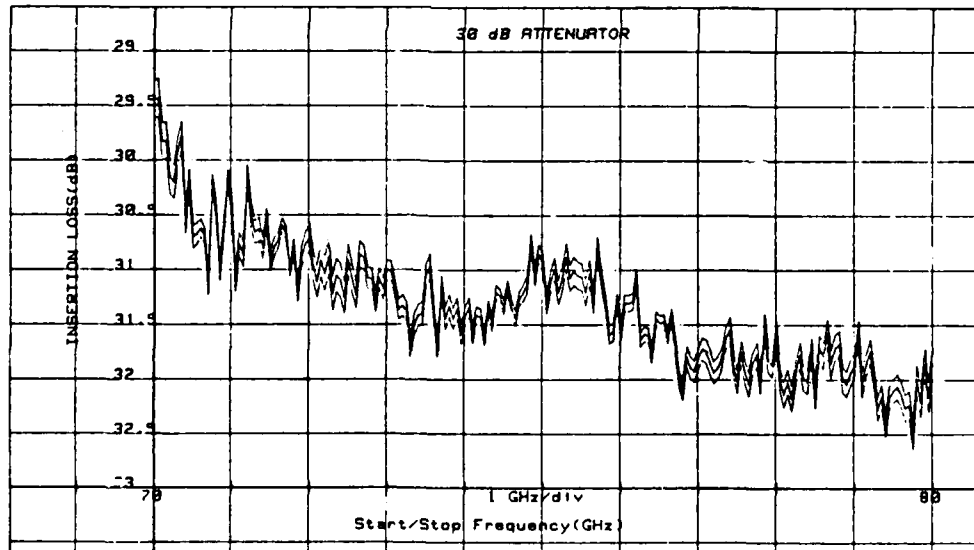

b. Improved System.

Figure 38. 30 dB Attenuator Insertion Loss Comparison from 70-80 GHz.

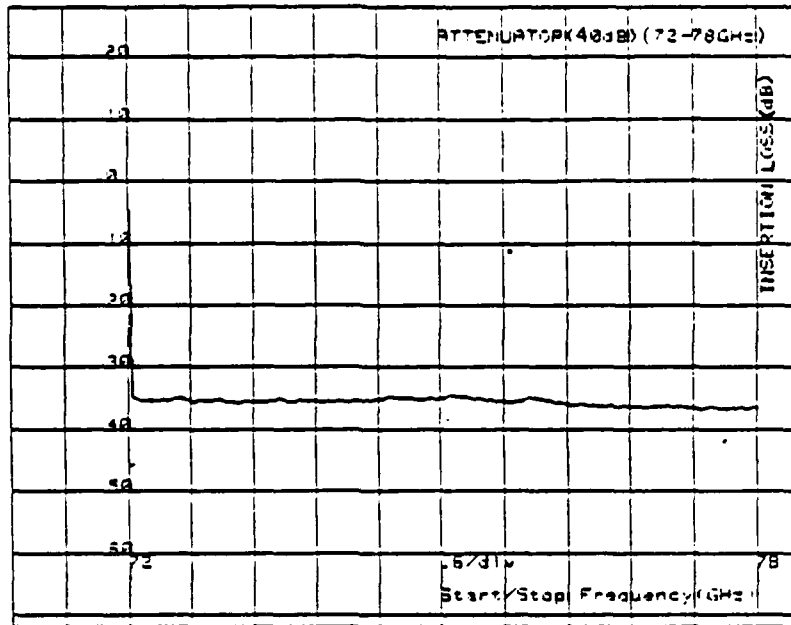

a. Old System.

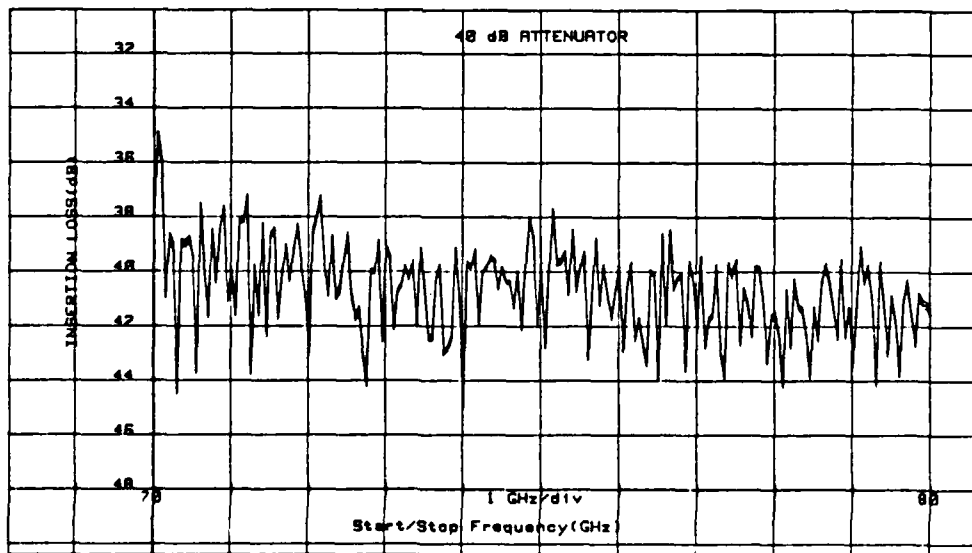

b. Improved System.

Figure 39. 40 dB Attenuator Insertion Loss Comparison from 70-80 GHz.

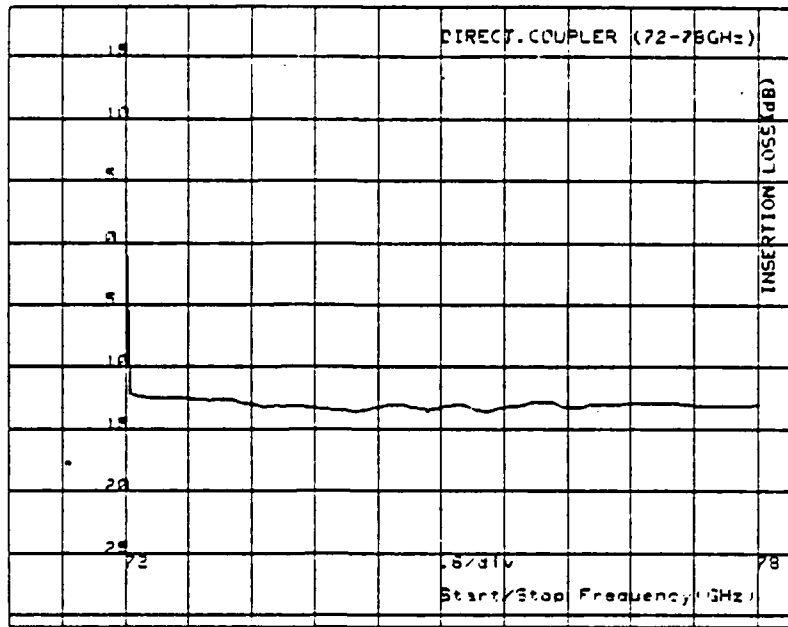

a. Old System.

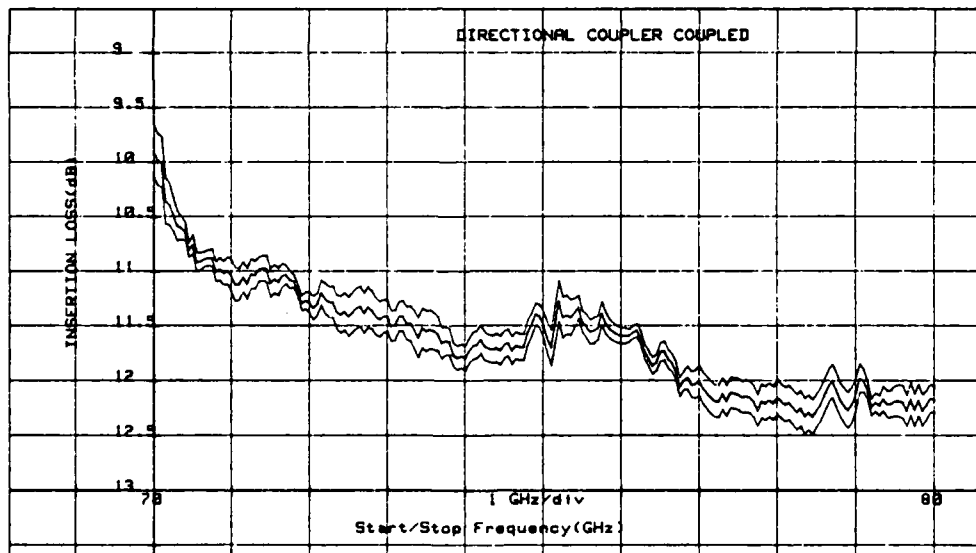

b. Improved System.

Figure 40. Directional Coupler Insertion Loss Comparison from 70-80 GHz.

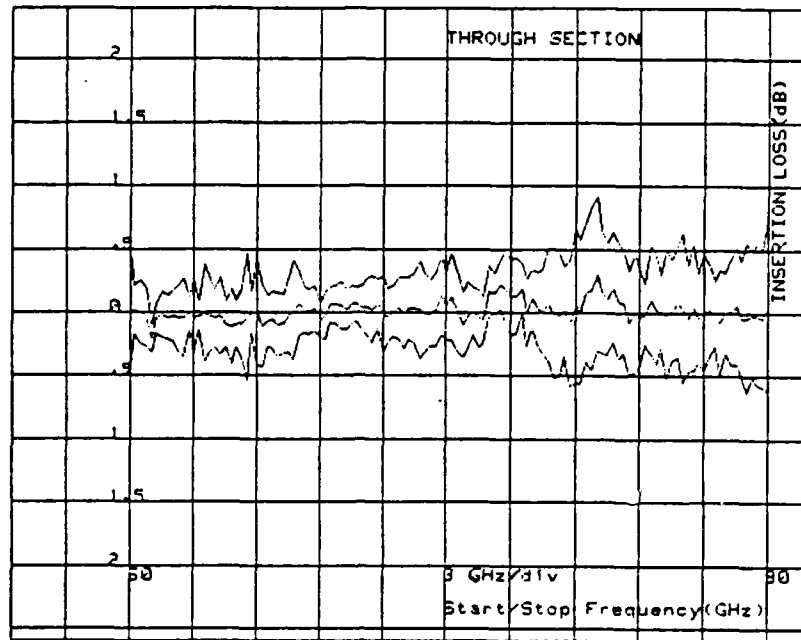

a. Old System.

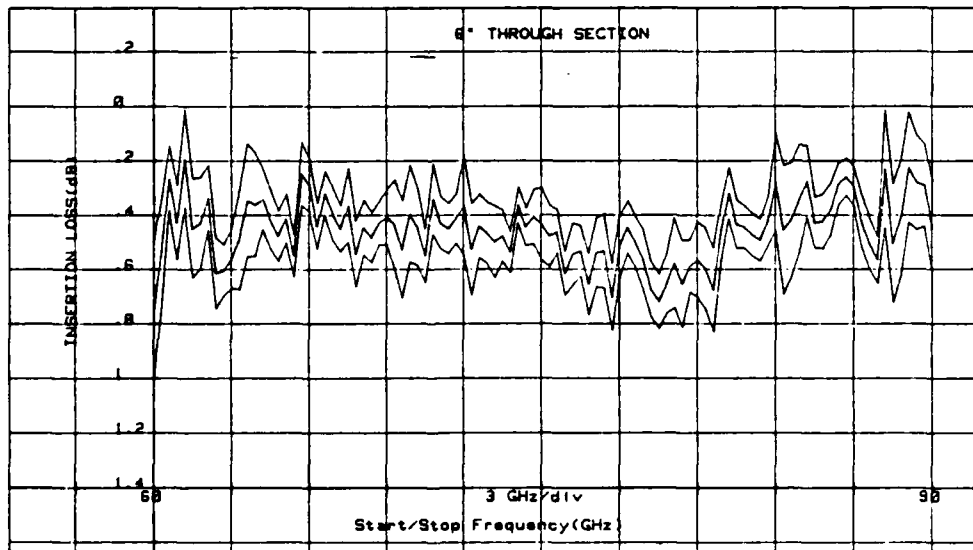

b. Improved System.

Figure 41. Through Section Insertion Loss Comparison from 60-90 GHz.

appear that the through section was of zero length since the insertion loss was approximately 0 dB. For the improved system, a 6 inch through section was used. The typical loss of E-band waveguide is about 1 dB/ft. As one can see from Figure 41b, the insertion loss measurement hovers around 0.5 dB, the expected value of the insertion loss.

g. Baytron Variable Attenuator from 60 to 90 GHz.

The full band comparison of the Baytron 3E-3 Variable Attenuator set at 10 dB can be seen in Figure 42. Despite the rather poor performance of the attenuator, the range of insertion loss values from 60 to 90 GHz between the two systems agree very well. The attenuator is calibrated for a correct reading at 75 GHz. Both systems came very close to this reading although the improved system appeared closer and the uncertainty range was much tighter.

C. PLOTTER PERFORMANCE

One of the major improvements to the Millimeter-Wave Scalar Network Analyzer system was the ability to produce a graphical output on the HP-9872 Plotter. In the previous comparisons the old outputs were produced from the HP-9845B Computer internal thermal printer while the new outputs were produced on the HP-9872C Plotter. The plotter outputs are significantly clearer with excellent resolution and contrast. By using the plotter the user can also vary the size of the output and use different colored pens to enhance

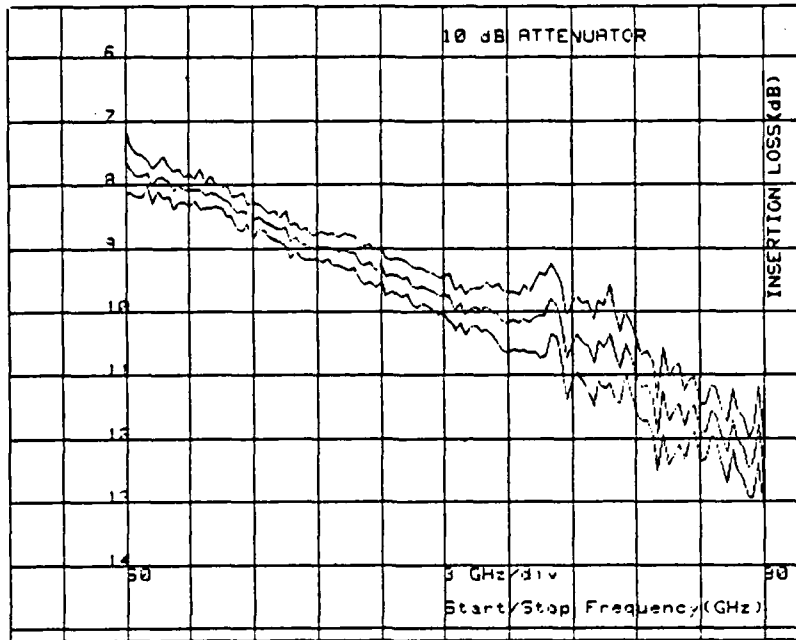

a. Old System.

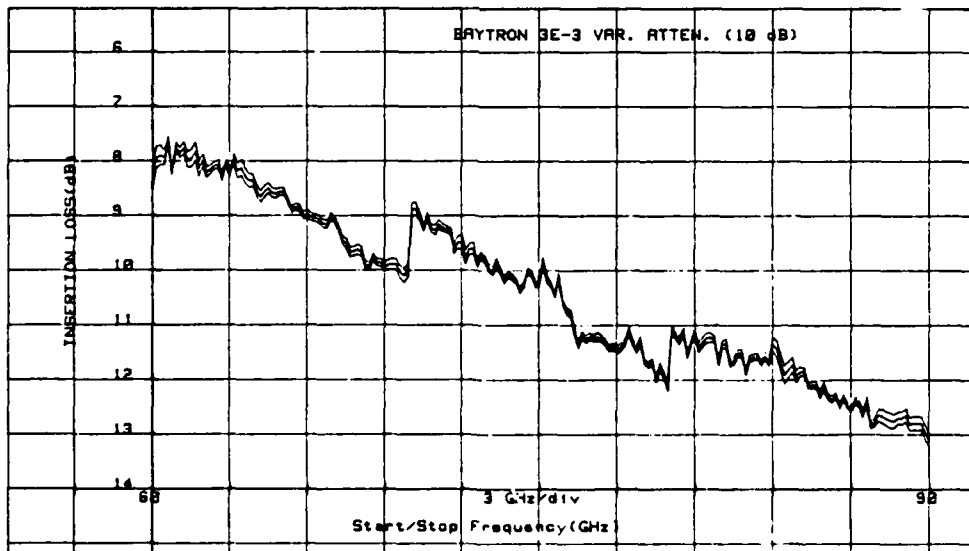

b. Improved System.

Figure 42. Baytron Variable Attenuator Insertion Loss Comparison at 10 dB from 60-90 GHz.

the graphical output. Neither of these features were available with the internal thermal printer. Some programming knowledge would be necessary to change the existing parameters in the "MMWSNA" program.

IV. CONCLUSIONS AND RECOMMENDATIONS

A. CONCLUSIONS

The Improved Millimeter-Wave Scalar Network Analyzer exhibits better overall performance than its predecessor. The addition of the Schottky barrier diode detector and the HP-8756A Scalar Network Analyzer provides a dynamic range which rivals industry standards. Software modification and computer control of the HP-8350B Sweeper Controller and the HP-8756A Scalar Network Analyzer has reduced user interface and speeded up the measurement process. By providing all of the previous output capabilities as well as the HP-9872C Plotter output, the system is able to give the user a maximum amount of clear data for analysis. The system is composed of off-the-shelf components so anyone desiring such a system is able to obtain the necessary equipment.

B. RECOMMENDATIONS

Despite this system's improved performance over any previous system, some system improvements can still be made and some anomalies looked into.

1. Schottky Barrier Diode Detectors

The performance of this diode detector is excellent and it is recommended that the A, B and R couplers be fitted with these detectors. This will ensure peak performance and maximum user friendliness for insertion loss measurements.

2. Measurement Accuracy

Both the return loss and insertion loss measurement accuracies were 1-2 dB above the maximum rated tolerance of the calibrated variable attenuator which was used. Some of the device measurements, however were exactly where one would expect them to be (Baytron Attenuator and the Through Section). It is not obvious where the source of this anomaly is and further investigation is in order.

3. Band Switch Jumps

In the insertion loss measurements, significant jumps in dB level occur at the band switch frequencies of 70 and 80 GHz. It is unclear why these discontinuities occur and further investigation into the problem and its solution should be pursued.

4. Maximum Uncertainty Calculation

As was discussed in Chapter III, the maximum uncertainty of high return loss devices sometimes becomes uncalculable because the computation only takes into consideration the worst case coupler directivity. The plot may be more meaningful if the actual coupler directivity could be determined for each of the test frequencies and this value entered into the maximum uncertainty calculation. Another approach might be to investigate an equivalent expression for computing the uncertainty which would prevent forbidden function arguments from occurring.

5. Plotter Parameters

Currently the only plotter in the program is the HP-9872 series. The parameters as to graph size and pen number has been entered into the computer code and can only be changed by altering the code. The program could be enhanced by prompting the user with a number of possible plotter selections as well as providing the user with the ability to determine the graph size and orientation and allowing the user to select which pen is to be used for the grid, labels, measurement plot, uncertainty plots, etc.

APPENDIX A
USER'S GUIDE

A. SYSTEM CONNECTIONS

1. HP-IB should connect the HP-9845B Computer, HP-9872C Plotter and HP-8756A Scalar Network Analyzer.
2. The system bus should connect the HP-8756A Scalar Network Analyzer and the HP-8350B Sweeper Controller.
3. Ensure that the Hughes Millimeter-Wave Plug-In is properly seated in the HP-8350B adapter and the ROM modification installed, and that the unit is seated in the Sweeper Controller. Make Reflectometer connections to the front of the Plug-In.

B. SYSTEM START-UP

Once all connections are made turn on the units. Default selections will be initiated on the Sweeper Controller and the Scalar Network Analyzer. These values need not be changed as the program will take care of this later.

C. SYSTEM INITIALIZATION

1. Load the program from either disk or tape.
2. Press RUN.
3. The computer will display the scft key menu for output and the operator has the following options:

- a. Using the key number six (K6), the operator can read previously obtained and stored data from the disk or tape. By pressing K6 the computer asks the operator if he wants data from the Disk (D) or Tape (C) and he can select either one and press CONT. Wrong choices will result in a continued prompt for an acceptable choice. The computer will then prompt for the name of the data file. Enter the name and press CONT. The computer reads the data from the file and then returns to the soft key menu. The operator may now either DISPLAY (K2) or PRINT (K3) the data.
- b. Using the key K0, SELECT TYPE OF MEASUREMENT, the operator can select any particular measurement he wants by pressing:
- K1 Insertion Loss
 - K2 Return Loss
 - K3 Both.
- c. Once the selection of measurement is made the operator then enters the "DATA ENTRY" routine. The computer will ask the following:
- (1) START frequency (GHz)
 - (2) STOP frequency (GHz)
- A WARNING may come up at this point which is addressed in Chapter II, Section 4. The program

will allow the operator to reenter the START/
STOP frequencies or the operator may continue.

(3) A menu of the number of data points desired for the measurement is then presented and the operator enters the appropriate letter. The number of data points may not be changed without RESTARTING the program.

At this point the system is initialized and the program goes to the measurement subroutine selected.

D. RETURN LOSS MEASUREMENTS

1. The calibration routine is executed first. The operator is prompted to connect the adjustable short and press CONT. Refer to Figure 2a for the connection with the sliding short as the DUT. As the program is executed the operator is prompted to move the sliding short to 10 different positions. It is recommended that the operator move the sliding short from its minimum position to its maximum position in 10 equal steps ensuring that the length of travel exceeds 2.5 mm to allow proper computation of the maximum and minimum calibration averages.
2. The program now executes the Device measurement subroutine, the operator connects the DUT and labels it (up to 32 characters).

3. Once the measurement is made the soft key main menu comes up and the operator may now select an appropriate output (See OUTPUT section).

E. INSERTION LOSS MEASUREMENTS

1. The operator is first asked if the A-coupler will be removed during the Insertion Loss calibration or measurement which he must answer "Y" for yes or "N" for no.
2. The program first executes the Return Loss Calibration if it has not done so already (Refer to Section D1).
3. The program will ask the operator to connect the B-coupler and the reflection coefficient of the B-coupler will be measured, $|\Gamma_L|$.
4. The software will ask the operator to connect the DUT and its input reflection coefficient will be measured (S_{11}^{DUT}) followed by the output reflection coefficient measurement (S_{22}^{DUT}). In both cases the maximum reflection coefficient will be evaluated using the value of $|S_{22}|$ from the calibration data.
5. Based on whether or not the A-coupler is present, the program will now compute the value of $|\Gamma_s|$. The program then executes the Insertion Loss Calibration Average subroutine and the value of the calibration

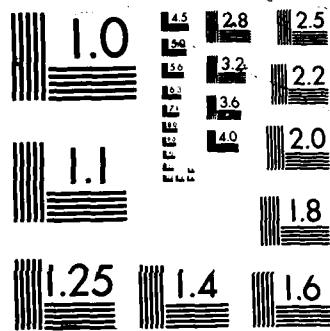

XEROCOPY RESOLUTION TEST CHART

average (Through) is measured. No operator input is needed for this step.

6. The device under test is now inserted and the $|S_{12}^{DUT}|$ is measured followed by the measurement of the $|S_{21}^{DUT}|$ which is in fact the Device Measurement.
7. The operator will now label the device and upon pressing CONT the program will return to the soft key main menu for output selection.

F. OUTPUT

1. The following options are available from the soft key menu for the output:
 - a. K1 PLOT DATA. The computer executes successively the subroutines Initialize, Compute scale, Label scale, Label frequency, Label device, Label loss and Plot data. At this point the operator may choose to output the graph to the internal thermal printer (Press "P"), to the HP-9872 Plotter (after placing paper in the "landscape" position and pressing "Q") or returning to the soft key menu by pressing CONT.
 - b. K2 DISPLAY DATA. The computer executes the display data subroutine. Eleven lines are

displayed each time the operator presses the CONT key.

c. K3 PRINT DATA. The computer executes the print data subroutine, data are printed and the program resumes the soft key main menu.

d. K7 PRINT INTERMEDIATE VALUES - INSERTION. The operator has two options:

(1) DISPLAY DATA (K7, CONT)

(2) PRINT DATA (K7, Y, CONT)

Note that since these values are the same and independent of the DUT one copy of them is needed. The values which are presented are:

(1) $|S_{21}|^{DUT}$

(2) $|S_{12}|^{DUT}$

(3) $|S_{11}|^{DUT} MAX$

(4) $|S_{22}|^{DUT} MAX$

(5) $|\Gamma_s|$

(6) $|\Gamma_L|$

(7) Avg. = Insertion loss Calibration Average (Through).

e. K9 PRINT INTERMEDIATE VALUES - RETURN LOSS.

The operator has two options:

(1) DISPLAY DATA (K9, CONT)

(2) PRINT DATA (K9, Y, CONT)

Note that since these values are the same and independent of the DUT one copy of them

is needed. The values which are presented are:

- (1) R1(X) = Maximum Calibration Average
- (2) R2(X) = Minimum Calibration Average
- (3) R(X) = Calibration Average
- (4) R6(X) = S_{22} of Calibration Data.

f. K5 STORE DATA TO A DISK OR CASSETTE. The program executes the disk storage subroutine. The operator has two options:

- (1) Store data into a disk (K5, D, CONT, FILE NAME, CONT), here mass storage is ":Fn".
- (2) Store data into a cassette (K5, C, CONT, FILE NAME, CONT), mass storage is ":Tn (default is T15).

Disk storage is preferred since access time is less on disk. The operator can use up to six (6) characters to name the file and care must be taken here to avoid duplicate file names. Regardless of the file name, the original DUT label will remain the same. After data storage the program returns to the soft key main menu.

g. K4 NEXT MEASUREMENT. The program executes the Device measurement subroutine. The same calibration data will be used for any DUT at the same frequency range. The operator

should insert the new DUT and then press the CONT key. The Return Loss and/or Insertion Loss subroutines will be followed minus the calibration portions (D1 and E2,3).

- h. K8 RESTART. The program resumes the TYPE OF MEASUREMENT menu for a completely new measurement beginning at C3b of the Users Guide.

APPENDIX B
PROGRAM LISTING AND VARIABLES

A. PROGRAM LISTING

The program used for the improved Millimeter-Wave Scalar Network Analyzer is "MMWSNA". This program is available on Hewlett Packard 8-1/2" single sided floppy disk or on HP tape and a listing is provided at the end of this Appendix.

B. LIST OF VARIABLES

The variables used for the "MMWSNA" program along with their definition are as follows:

- A - Start frequency (GHz)
- A0 - HP-8756A Scalar Network Analyzer address
- A\$ - Temporary string variable
- B - Stop frequency (GHz)
- B\$ - Data storage device type
- C - Band sweep time (msec)
- D(X) - Data points for loss computation
- D1(X) - Temporary variable for low-band data points
- D2(X) - Temporary variable for mid-band data points
- D3(X) - Temporary variable for high-band data points
- D10(X,Y) - Return loss calibration data points
- F - Data point frequency for printout
- F1 - Mid-band measurement flag

F2 - High-band measurement flag
 F5 - Frequency START/STOP warning flag
 F\$ - Data file name
 H - Insertion Loss Calibration Flag
 H1 - Return Loss Calibration Flag
 I - Loop variable
 I\$ - Temporary string variable
 J - Loop variable
 K - Maximum calibration average in dB for printout
 L - Minimum calibration average in dB for printout
 M3 - Total plot range (dB)
 M4 - Maximum plot value (dB)
 M5 - Intermediate plot markings
 M6 - Linear Average of the Maximum and Minimum Loss (dB)
 M7 - Temporary variable for computing maximum value of plotting scale
 M8 - Maximum Loss (dB)
 M9 - Minimum Loss (dB)
 N - Mode (1=Insertion, 2=Return, 3=Both)
 N1 - Plotting flag for Insertion Loss
 N\$ - Label for DUT
 P - Step counter based on number of data points
 P0 - HP-9872 Plotter address
 P1 - Maximum value for plotting loop

P#	- Label for type of loss
R(X)	- Linear average of the calibration maximum and minimum
R1(X)	- Maximum calibration average
R2(X)	- Minimum calibration average
R3(X)	- Uncertainty of Return Loss
R4(X)	- Maximum value of Return Loss
R5(X)	- Minimum value of Return Loss
R6(X)	- S_{22} of calibration data
R7(X)	- Uncertainty of S_{22}^{DUT} measurement
R8(X)	- Uncertainty of S_{22}^{DUT} measurement
R9(X)	- DUT input reflection coefficient
R10(X)	- S_{12}^{DUT}
R11(X)	- S_{21}^{DUT} and Insertion Loss
R12(X)	- Maximum value of Insertion Loss
R13(X)	- Γ_L'
R14(X)	- Γ_s'
R15(X)	- Insertion Loss Calibration Average
R16(X)	- Minimum value of Insertion Loss
R17(X)	- Maximum value of S_{11}^{DUT}
R18(X)	- Maximum value of S_{22}^{DUT}
R19(X)	- Return Loss
S0	- HP-8350B Sweeper Controller address
S1	- Band start frequency
S2	- Band stop frequency
W	- Loop variable

X - Loop variable
X1 - Loop variable
X2 - Loop variable
Y - Data point index counter
Z - S_{21}^{DUT} in dB for printout

PROGRAM LISTING

```

10 |
20 | ***** M M W S N A *****
30 |
40 |
50 | This program was developed by David E. Falkner, LT, USN.
60 | It is a modification of the "AEK" PROGRAM developed by
70 | ELIA GATSOS (LT) HELLENIC NAVY
80 | The features of this PROGRAM are :
90 | RETURN and/or INSERTION LOSS MEASUREMENTS,
100 | COMPUTATION of RETURN and INSERTION LOSS UNCERTAINTIES,
110 | DISPLAY , PRINT , STORE , READ of all parameters involved,
120 | PLOTTING of results on either the HP-9845 thermal printer
130 | or the HP-9872 plotter.
140 | This set up uses:
150 | (a)HP-8350B SWEEP OSCILLATOR with HUGHES 60-90 GHz Plug-in,
160 | (b)HP-8756A SCALAR NETWORK ANALYZER,
170 | (c)HP-9845B COMPUTER,
180 | (d)HP-9872C PLOTTER.
190 |
200 | ***** MAIN PROGRAM *****
210 |
220 | GOTO 340
230 | GOSUB 720 ! INITIALIZE
240 | GOSUB 910 ! PLUG-IN
250 | GOSUB 990 ! START/STOP
260 | H1=0
270 | IF N<>1 THEN GOSUB 1810! RETURN LOSS CALIBRATION
280 | IF N<>1 THEN GOSUB 3970! MEASURE RETURN LOSS
290 | IF N<>2 THEN GOSUB 2250! INSERTION LOSS MEASUREMENT
300 | IF N=1 THEN GOSUB 4020
310 |
320 | Soft-key menu for output
330 |
340 | BEEP
350 | DISP
360 | GCLEAR
370 | PRINT PAGE
380 | PRINT LIN(16),CHR$(131);"SELECT FUNCTION:";CHR$(128)
390 | PRINT
400 | PRINT
410 | PRINT "k0:Select type of Measurement(INSERTION,REFLECTION,BOTH)"
420 | PRINT
430 | PRINT "k1:PLOT data k2:DISPLAY data k3:PRINT data k4:NEXT meas k8:RESTART"
440 | PRINT
450 | PRINT "k5:STORE data to DISK or TAPE k6:READ data from DISK or TAPE "
460 | PRINT
470 | PRINT "K7:Display intermediate values for INSERTION "
480 | PRINT
490 | PRINT "k9:Display intermediate values for REFLECTION "
500 | PRINT
510 | ON KEY #0 GOTO 230
520 | ON KEY #1 GOTO 4360
530 | ON KEY #2 GOTO 5850
540 | ON KEY #3 GOTO 6190
550 | ON KEY #4 GOTO 280
560 | ON KEY #5 GOTO 7620
570 | ON KEY #6 GOTO 7850
580 | ON KEY #7 GOTO 8040
590 | ON KEY #8 GOTO 620
600 | ON KEY #9 GOTO 8510
610 | GOTO 610
620 | OFF KEY #4
630 | OFF KEY #8
640 | GOTO 230
650 |
660 |

```

```

670 ! SUBROUTINES
680 !
690 !
700 ! INITIALIZE
710 !
720 OPTION BASE 1
730 COM S#[32],P#[24],SHORT D(401),N#[32]
740 SHORT R(401),R1(401),R2(401),R3(401),R4(401),R5(401),R6(401),R7(401),R8(401)
750 SHORT R9(401),R10(401),R11(401),R12(401),R13(401),R14(401),R15(401),R16(401)
760 SHORT R17(401),R18(401),R19(401)
770 SET TIMEOUT 7;5000
780 ABORTIO 7
790 CLEAR 7
800 LOCAL 7
810 REMOTE 7
820 S0=717 !8350B SWEEPER select
830 A0=716 !8756A NETWORK ANALYZER select
840 P0=705 !9872C PLOTTER select
850 PRINTER IS 16
860 H=0
870 RETURN
880 !
890 ! <PLUG-IN BAND LIMITS>
900 !
910 RESTORE 940
920 READ L
930 READ U
940 DATA 60,90
950 RETURN
960 !
970 ! <DATA ENTRY>
980 !
990 PRINT PAGE
1000 PRINT LIN(10),CHR$(131);" SELECT MEASUREMENT :";CHR$(128)
1010 DISP "k1: Insertion loss      k2: Return loss      k3: Both      "
1020 F=0
1030 ON KEY #1 GOTO 1070
1040 ON KEY #2 GOTO 1090
1050 ON KEY #3 GOTO 1110
1060 GOTO 1060
1070 N=1
1080 GOTO 1120
1090 N=2
1100 GOTO 1120
1110 N=3
1120 F5=0
1130 PRINT PAGE
1140 PRINT LIN(10),CHR$(131);" DATA ENTRY: ";CHR$(128)
1150 PRINT "All frequencies are entered in GHz.Both channels of 8756 same sensi
t."
1160 DISP "START Frequency (GHz) ";
1170 INPUT A
1180 IF (A<=U) AND (A>=L) THEN GOTO 1210
1190 BEEP
1200 GOTO 1160
1210 DISP "STOP Frequency (GHz)";
1220 INPUT B
1230 IF (B<=U) AND (B>=L) THEN GOTO 1260
1240 BEEP
1250 GOTO 1210
1260 IF A<B THEN GOTO 1290
1270 BEEP
1280 GOTO 1120
1290 IF F5=1 THEN GOTO 1450
1300 IF (F5=0) AND ((A<>60) AND (A<>70) AND (A<>80)) THEN GOTO 1330
1310 IF (F5=0) AND ((B<>70) AND (B<>80) AND (B<>90)) THEN GOTO 1330

```

```

1320 GOTO 1450
1330 PRINT PAGE
1340 PRINT LIN(10),TAB(25),CHR$(131);" >>> WARNING <<< ";CHR$(128)
1350 PRINT LIN(2);"Measurements taken with endpoints other than 60, 70, 80, or"
1360 PRINT "90 GHz may result in misleading data. In these cases separate band
"
1370 PRINT "measurements should be made."
1380 PRINT LIN(10)
1390 DISP
1400 DISP "Do you want to continue with the present START/STOP frequencies (Y/N
)?";
1410 INPUT T$
1420 IF T$="Y" THEN GOTO 1450
1430 F5=1
1440 GOTO 1130
1450 C=100
1460 PRINT PAGE
1470 PRINT LIN(16);"SELECT LETTER CORRESPONDING TO THE DESIRED NUMBER OF DATA P
OINTS:"
1480 PRINT
1490 PRINT TAB(10);"A: 10 DATA POINTS"
1500 PRINT TAB(10);"B: 25 DATA POINTS"
1510 PRINT TAB(10);"C: 50 DATA POINTS"
1520 PRINT TAB(10);"D: 80 DATA POINTS"
1530 PRINT TAB(10);"E: 100 DATA POINTS"
1540 PRINT TAB(10);"F: 200 DATA POINTS"
1550 PRINT TAB(10);"G: 400 DATA POINTS"
1560 P=0
1570 INPUT I$
1580 IF I$="A" THEN P=40
1590 IF I$="B" THEN P=15
1600 IF I$="C" THEN P=8
1610 IF I$="D" THEN P=5
1620 IF I$="E" THEN P=4
1630 IF I$="F" THEN P=2
1640 IF I$="G" THEN P=1
1650 IF P<>0 THEN GOTO 1680
1660 BEEP
1670 GOTO 1460
1680 PRINT PAGE
1690 PRINT LIN(12),TAB(15),CHR$(131);" INITIALIZING...PLEASE WAIT ";CHR$(128)
1700 OUTPUT A0;"PT19"
1710 OUTPUT S0;"IP"
1720 OUTPUT A0;"IP"
1730 WAIT 4000
1740 OUTPUT A0;"C2"
1750 OUTPUT A0;"C0"
1760 OUTPUT A0;"RP6"
1770 RETURN
1780 !
1790 ! <RETURN LOSS CAL.>
1800 !
1810 PRINT PAGE
1820 SHORT D10(10,401)
1830 PRINT LIN(10),TAB(20),CHR$(131);" RETURN LOSS CALIBRATION ";CHR$(128)
1840 H1=1
1850 DISP "Connect the adjustable short and press CONT."
1860 BEEP
1870 PAUSE
1880 DISP " "
1890 FOR J=1 TO 10
1900 IF J=1 THEN GOTO 1950
1910 PRINT PAGE
1920 DISP "Change position of adjustable short and press CONT after BEEP."
1930 PAUSE
1940 DISP " "

```

```

1950 OUTPUT A0;"AR" ! *** SELECT A/R MEASUREMENT ***
1960 GOSUB 7310 ! *** 8350 SETUP ***
1970 GOSUB 6620 ! *** READ 8756 ***
1980 FOR X=1 TO 401 STEP P
1990 D10(J,X)=D(X)
2000 NEXT X
2010 BEEP
2020 NEXT J
2030 PRINT PAGE
2040 PRINT LIN(12),TAB(10),CHR$(131);" COMPUTING CALIBRATION AVERAGE...PLEASE W
AIT ";CHR$(128)
2050 MAT R1=(0)
2060 MAT R2=(0)
2070 ! R1(X)<Maximum calibration average>=SQR(Va/Vr)
2080 ! R2(X)<Minimum calibration average>=SQR(Va/Vr)
2090 FOR X=1 TO 401 STEP P
2100 R1(X)=D10(1,X)
2110 R2(X)=D10(1,X)
2120 NEXT X
2130 FOR X=1 TO 401 STEP P
2140 FOR J=2 TO 10
2150 IF D10(J,X)>R1(X) THEN R1(X)=D10(J,X)
2160 IF D10(J,X)<R2(X) THEN R2(X)=D10(J,X)
2170 ! R(X)<Linear average of the max and min>
2180 R(X)=(10^(R1(X)/20)+10^(R2(X)/20))/2
2190 NEXT J
2200 NEXT X
2210 RETURN
2220 !
2230 ! <INSERTION LOSS CAL. FOR S11 AND S22>
2240 !
2250 PRINT PAGE
2260 INPUT "Will A-coupler be removed during Insertion Loss calibration or meas
urement (Y/N)",A$
2270 IF (A$="Y") OR (A$="N") THEN GOTO 2300
2280 PRINT "Select either 'Y' OR 'N'"
2290 GOTO 2260
2300 IF H=1 THEN GOTO 2520
2310 PRINT LIN(8),TAB(20),CHR$(131);" INSERTION LOSS CALIBRATION ";CHR$(128);LI
N(1)
2320 PRINT
2330 IF H1=1 THEN GOTO 2350
2340 GOSUB 1850
2350 PRINT PAGE
2360 PRINT "GAMMA-L' computation "
2370 PRINT "-----"
2380 PRINT "A/R, Connect the B coupler to the Test Port and press CONT."
2390 BEEP
2400 PAUSE
2410 DISP "...taking data."
2420 GOSUB 7310 ! *** SETUP 8350 ***
2430 GOSUB 6620 ! *** Read 8756 ***
2440 FOR X=1 TO 401 STEP P
2450 ! R13(X)=GAMMA-L'
2460 R13(X)=10^(D(X)/20)/R(X)
2470 NEXT X
2480 IF A$="N" THEN GOTO 3030
2490 !
2500 ! <INSERTION LOSS S11 AND S22 MEASUREMENT>
2510 !
2520 PRINT PAGE
2530 DISP
2540 M8=-9.999999999999999E99
2550 M9=9.999999999999999E99
2560 PRINT "S11-DUT|Max computation "
2570 PRINT "-----"

```



```

2580 PRINT "A/R,Connect the device under test in the forward direction "
2590 PRINT " and press CONT "
2600 BEEP
2610 PAUSE
2620 DISP "....taking data."
2630 GOSUB 7310 ! *** SETUP 8350 ***
2640 OUTPUT A0;"AR"
2650 GOSUB 6620 ! *** Read 8756 ***
2660 FOR X=1 TO 401 STEP P
2670 ! R6=(S22 of calibration data)
2680 ! R9=(Reflection coefficient)
2690 ! R7(X)=(Uncertainty of the measurement)
2700 ! R17(X)=(Max value of S11-DUT)
2710 R6=ABS(10^(R1(X)/20)-10^(R2(X)/20))/(10^(R1(X)/20)+10^(R2(X)/20))
2720 R9=10^(D(X)/20)/R(X)
2730 R7(X)=R9*R9*R6+.01
2740 R17(X)=R7(X)+R9
2750 NEXT X
2760 IF A$="N" THEN GOTO 3500
2770 PRINT PAGE
2780 DISP
2790 PRINT "S22-DUT|Max computation "
2800 PRINT "-----"
2810 PRINT "A/R,Connect the device under test in the reverse direction "
2820 PRINT "and press CONT"
2830 BEEP
2840 PAUSE
2850 DISP "....taking data."
2860 GOSUB 7310 ! *** SETUP 8350 ***
2870 OUTPUT A0;"AR"
2880 GOSUB 6620 ! *** READ 8756 ***
2890 FOR X=1 TO 401 STEP P
2900 ! R6=(S22 of calibration data)
2910 ! R9=(Reflection coefficient)
2920 ! R8(X)=(Uncertainty of measurements)
2930 ! R18(X)=(Max value of S22-DUT)
2940 R6=ABS(10^(R1(X)/20)-10^(R2(X)/20))/(10^(R1(X)/20)+10^(R2(X)/20))
2950 R9=10^(D(X)/20)/R(X)
2960 R8(X)=R9*R9*R6+.01
2970 R18(X)=R8(X)+R9
2980 NEXT X
2990 IF A$="N" THEN GOTO 3330
3000 !
3010 ! < INSERTION LOSS CAL. FOR S12 AND S21 >
3020 !
3030 PRINT PAGE
3040 IF A$="Y" THEN GOTO 3080
3050 PRINT "GAMMA-S' computation and INSERTION LOSS CALIBRATION "
3060 PRINT "-----"
3070 IF A$="N" THEN GOTO 3160
3080 PRINT "GAMMA-S' computation and INSERTION LOSS CALIBRATION "
3090 PRINT "-----"
3100 PRINT "Change A/R to B/R THEN Remove A-coupler,Insert the B coupler and"
3110 IF H=1 THEN GOTO 3370
3120 PRINT "press CONT"
3130 H=1
3140 BEEP
3150 PAUSE
3160 DISP "....taking data."
3170 GOSUB 7310 ! *** SETUP 8350 ***
3180 OUTPUT A0;"BR"
3190 GOSUB 6620 ! *** READ 8756 ***
3200 FOR X=1 TO 401 STEP P
3210 ! R14(X)=(GAMMA-S'=.2 if A-coupler is removed)
3220 IF A$="Y" THEN R14(X)=.2
3230 R6=ABS(10^(R1(X)/20)-10^(R2(X)/20))/(10^(R1(X)/20)+10^(R2(X)/20))

```

```

3240 ! R14(X)=(GAMMA-S'/S22<from calibration data>+.05 if A-coupler is in)
3250 IF A$="N" THEN R14(X)=R6+.05
3260 ! R15(X)=(Insertion Loss Calibration Average)
3270 R15(X)=10^(D(X)/20)
3280 NEXT X
3290 IF A$="N" THEN GOTO 2520
3300 !
3310 ! <INSERTION LOSS S12 AND S21 MEASUREMENT>
3320 !
3330 PRINT PAGE
3340 PRINT "S12-DUT computation "
3350 PRINT "-----"
3360 IF A$="N" THEN GOTO 3410
3370 PRINT "Connect the device under test (in the reverse direction)"
3380 PRINT " and press CONT"
3390 BEEP
3400 PAUSE
3410 DISP "....taking data."
3420 GOSUB 7310 ! *** SETUP 8350 ***
3430 OUTPUT A0;"BR"
3440 GOSUB 6630 ! *** READ 8756 ***
3450 FOR X=1 TO 401 STEP P
3460 ! R10(X)=(S12-DUT)
3470 R10(X)=10^(D(X)/20)/R15(X)
3480 NEXT X
3490 IF A$="N" THEN GOTO 3700
3500 PRINT PAGE
3510 PRINT "S21-DUT computation "
3520 PRINT "-----"
3530 IF A$="N" THEN GOTO 3580
3540 PRINT "Connect the device under test (in the forward direction)"
3550 PRINT " and press CONT"
3560 BEEP
3570 PAUSE
3580 DISP "Taking data ...."
3590 M8=-9.999999999999999E99
3600 M9=9.999999999999999E99
3610 GOSUB 7310 ! *** SETUP 8350 ***
3620 OUTPUT A0;"BR"
3630 GOSUB 6620 ! *** READ 8756 ***
3640 FOR X=1 TO 401 STEP P
3650 ! R11(X)=(S21-DUT)
3660 R11(X)=10^(D(X)/20)/R15(X)
3670 NEXT X
3680 IF A$="N" THEN GOTO 2770
3690 !
3700 ! <INSERTION LOSS COMPUTATION>
3710 !
3720 PRINT PAGE
3730 DISP
3740 PRINT LIN(12),TAB(15),CHR$(131);" COMPUTING INSERTION LOSS ";CHR$(128)
3750 FOR X=1 TO 401 STEP P
3760 ! R12(X)=(1+(Gamma-S')*(Gamma-L'))*(S21-DUT)
3770 R12(X)=(1+R14(X)*R13(X))*ABS(R11(X))
3780 ! R9=(1-(Gamma-S')*(S11-DUT))*(1-(Gamma-L'))*(S22-DUT)-(S12-DUT)*(S21-DUT)
3790 * (Gamma-S')*(Gamma-L')
3790 R9=(1-R17(X)*R14(X))*(1-R18(X)*R13(X))-R10(X)*R11(X)*R13(X)*R14(X)
3800 ! R12(X)=(Maximum value of INSERTION LOSS)
3810 R12(X)=20*LGTR12(X)/ABS(R9))
3820 ! R16(X)=(1-(Gamma-S')*(Gamma-L'))*(S21-DUT)
3830 R16(X)=(1-R14(X)*R13(X))*ABS(R11(X))
3840 ! R9=(1+(Gamma-S')*(S11-DUT))*(1+(Gamma-L'))*(S22-DUT)+(S12-DUT)*(S21-DUT)*
3850 (Gamma-L')*(Gamma-S')
3850 R9=(1+R17(X)*R14(X))*(1+R18(X)*R13(X))+R10(X)*R11(X)*R13(X)*R14(X)
3860 ! R16(X)=(Minimum value of INSERTION LOSS)
3870 ! R11(X)=(INSERTION LOSS)

```

```

3880 R16(X)=20*LGT(R16(X)/ABS(R9))
3890 R11(X)=20*LGT(R11(X))
3900 M8=MAX(M8,R12(X))
3910 M9=MIN(M9,R16(X))
3920 NEXT X
3930 RETURN
3940 !
3950 ! <DEVICE MEASUREMENT - RETURN LOSS>
3960 !
3970 PRINT PAGE
3980 PRINT LIN(8),CHR$(131);"      DEVICE MEASUREMENT      ";CHR$(128);LIN(1)
3990 PRINT " Connect the Test Device to the Test Port and press CONT."
4000 BEEP
4010 PAUSE
4020 DISP
4030 BEEP
4040 LINPUT "Enter the Device label (up to 32 characters) and press the CONTINU
E key.",N$
4050 IF N=1 THEN RETURN
4060 DISP "Taking data..."
4070 M8=-9.999999999999999E99
4080 M9=9.999999999999999E99
4090 GOSUB 7310 ! *** SETUP 8350 ***
4100 OUTPUT A0;"AR"
4110 GOSUB 6620 ! *** READ 8756 ***
4120 FOR X=1 TO 401 STEP P
4130 ! R19(X)=(Return loss -linear)
4140 ! R6(X)=(S22 from calibration data)
4150 R19(X)=10^(D(X)/20)/R(X)
4160 R6(X)=ABS(10^(R1(X)/20)-10^(R2(X)/20))/(10^(R1(X)/20)+10^(R2(X)/20))
4170 ! R3(X)=(Uncertainty of RETURN LOSS MEASUREMENTS)
4180 R3(X)=R19(X)*R19(X)*R6(X)+.01
4190 ! R4(X)=(Maximum value of RETURN LOSS )
4200 R4(X)=20*LGT(R19(X)+R3(X))
4210 ! R5(X)=(Minimum value of RETURN LOSS )
4220 !
4230 ! If the uncertainty exceeds measurement then default
4240 !
4250 IF R3(X)<R19(X) THEN R5(X)=20*LGT(R19(X)-R3(X))
4260 IF R3(X)>R19(X) THEN R5(X)=20*LGT(10^(-6))
4270 R3(X)=20*LGT(R3(X))
4280 R19(X)=20*LGT(R19(X))
4290 IF R6(X)=0 THEN GOTO 4310
4300 R6(X)=20*LGT(R6(X))
4310 !
4320 M8=MAX(M8,R4(X))
4330 M9=MIN(M9,R5(X))
4340 NEXT X
4350 RETURN
4360 !
4370 ! <PLOT DATA>
4380 !
4390 N1=0
4400 IF N=1 THEN N1=1
4410 A$="N"
4420 ! SUBROUTINES FOR <PLOT DATA>
4430 GOSUB 4540 !Initialize
4440 GOSUB 4690 !Compute scale
4450 GOSUB 4830 !Label scale
4460 GOSUB 4940 !Label freq
4470 GOSUB 5080 !Label dev
4480 GOSUB 5140 !Label loss
4490 IF A$="Q" THEN RETURN
4500 GOSUB 5230 !Plot data
4510 GOTO 320 ! Return
4520 !

```

```

4530 ! Initialize
4540 PLOTTER IS 13,"GRAPHICS"
4550 GRAPHICS
4560 GCLEAR
4570 SCALE -185,1065,-1150,100
4580 PEN 1
4590 AXES 100,125,0,-1000
4600 IF A$="0" THEN PEN 2
4610 GRID 100,125,0,-1000
4620 IF A$="0" THEN PEN 1
4630 FRAME
4640 FRAME
4650 RETURN
4660 !
4670 ! Compute scale
4680 !
4690 FOR I=1 TO 8
4700 READ M3
4710 IF M3>=M8-M9+M3/8 THEN GOTO 4730
4720 NEXT I
4730 RESTORE 4740
4740 DATA .8,1.6,4,8,16,40,80,160
4750 M6=(M8+M9)/2
4760 M7=M6 MOD (M3/8)
4770 IF M7<=M3/16 THEN M4=M6-M7+M3/2
4780 IF M7>M3/16 THEN M4=M6-M7+M3/2+M3/8
4790 RETURN
4800 !
4810 ! Label scale
4820 !
4830 M5=M4
4840 LDIR 0
4850 FOR I=0 TO -1000 STEP -125
4860 MOVE -50,I
4870 LABEL VAL$(ABS(M5))
4880 M5=M5-M3/8
4890 NEXT I
4900 RETURN
4910 !
4920 ! Label frequency
4930 !
4940 LDIR 0
4950 MOVE -15,-1030
4960 LABEL VAL$(A)
4970 MOVE 985,-1030
4980 LABEL VAL$(B)
4990 T$=VAL$((B-A)/10)&" GHz/div"
5000 MOVE 430,-1030
5010 LABEL T$
5020 MOVE 260,-1095
5030 LABEL "Start/Stop Frequency(GHz)"
5040 RETURN
5050 !
5060 ! Label device
5070 !
5080 MOVE 390,30
5090 LABEL N$
5100 RETURN
5110 !
5120 ! Label loss
5130 !
5140 LDIR PI/2
5150 IF N1=1 THEN P$=" INSERTION LOSS<dB>"
5160 IF N1=0 THEN P$="RETURN LOSS<dB>"
5170 MOVE -100,-700
5180 LABEL P$

```

```

5190 RETURN
5200 !
5210 !       Plot data for RETURN LOSS
5220 !
5230 P1=401 ! *** NUMBER OF FREQUENCY POINTS ***
5240 IF N1=1 THEN GOTO 5370
5250 FOR X=0 TO P1-1 STEP P
5260 PLOT X*1000/(P1-1),-((M4-R19(X+1))*1000/M3)
5270 NEXT X
5280 PENUP
5290 IF A$="Q" THEN RETURN
5300 FOR X=0 TO P1-1 STEP P
5310 PLOT X*1000/(P1-1),-((M4-R4(X+1))*1000/M3)
5320 NEXT X
5330 PENUP
5340 IF A$="Q" THEN RETURN
5350 FOR X=0 TO P1-1 STEP P
5360 PLOT X*1000/(P1-1),-((M4-R5(X+1))*1000/M3)
5370 NEXT X
5380 PENUP
5390 IF A$="Q" THEN RETURN
5400 WAIT 3000
5410 PRINT PAGE
5420 A$="X"
5430 PRINT "Press P to output graph to 9845B printer,"
5440 PRINT "Press Q to output graph to 9872C plotter,"
5450 INPUT "otherwise just CONT",A$
5460 IF A$="P" THEN DUMP GRAPHICS
5470 IF A$="Q" THEN GOSUB 8960
5480 A$="X"
5490 IF N=2 THEN EXIT GRAPHICS
5500 IF N=2 THEN RETURN
5510 N1=1
5520 !
5530 ! Plot data for INSERTION LOSS
5540 !
5550 PRINT PAGE
5560 GOSUB 4410
5570 -FOR X=0 TO P1-1 STEP P
5580 PLOT X*1000/(P1-1),-((M4-R11(X+1))*1000/M3)
5590 NEXT X
5600 PENUP
5610 IF A$="Q" THEN RETURN
5620 FOR X=0 TO P1-1 STEP P
5630 PLOT X*1000/(P1-1),-((M4-R12(X+1))*1000/M3)
5640 NEXT X
5650 PENUP
5660 IF A$="Q" THEN RETURN
5670 FOR X=0 TO P1-1 STEP P
5680 PLOT X*1000/(P1-1),-((M4-R16(X+1))*1000/M3)
5690 NEXT X
5700 PENUP
5710 IF A$="Q" THEN RETURN
5720 WAIT 3000
5730 PRINT PAGE
5740 A$="X"
5750 PRINT "Press P to output graph to 9845B printer,"
5760 PRINT "Press Q to output graph to 9872C plotter,"
5770 INPUT "otherwise just CONT",A$
5780 IF A$="P" THEN DUMP GRAPHICS
5790 IF A$="Q" THEN GOSUB 9130
5800 EXIT GRAPHICS
5810 RETURN
5820 !
5830 ! <DISPLAY DATA>
5840 !

```

```

5850 P1=401! *** NUMBER OF FREQUENCY POINTS ***
5860 FOR X1=0 TO P1 STEP 11
5870 PRINT PAGE
5880 PRINT "DEVICE UNDER TEST : ",N$
5890 PRINT
5900 ON N GOSUB 6410,6450,6410
5910 FOR X2=1 TO 11*P STEP P
5920 X=X1+X2
5930 IF X>P1 THEN GOTO 5970
5940 F=(B-A)*(X-1)/(P1-1)+A
5950 ON N GOSUB 6520,6490,6520
5960 NEXT X2
5970 DISP "Press CONT..."
5980 PAUSE
5990 NEXT X1
6000 IF N<>3 THEN GOTO 320! RETURN
6010 FOR X1=0 TO P1 STEP 11
6020 PRINT PAGE
6030 PRINT "DEVICE UNDER TEST : ",N$
6040 PRINT
6050 GOSUB 6450
6060 FOR X2=1 TO 11*P STEP P
6070 X=X1+X2
6080 IF X>P1 THEN GOTO 6120
6090 F=(B-A)*(X-1)/(P1-1)+A
6100 GOSUB 6490
6110 NEXT X2
6120 DISP "Press CONT..."
6130 PAUSE
6140 NEXT X1
6150 GOTO 320 ! RETURN
6160 !
6170 ! <PRINT DATA>
6180 !
6190 P1=401 ! *** NUMBER OF FREQUENCY POINTS ***
6200 PRINTER IS 0
6210 PRINT "DEVICE UNDER TEST : ";N$
6220 PRINT
6230 ON N GOSUB 6410,6450,6410
6240 FOR X=1 TO P1 STEP P
6250 F=(B-A)*(X-1)/(P1-1)+A
6260 ON N GOSUB 6520,6490,6520
6270 NEXT X
6280 IF N<>3 THEN GOTO 6360
6290 PRINT "DEVICE UNDER TEST : ";N$
6300 PRINT
6310 GOSUB 6450
6320 FOR X=1 TO P1 STEP P
6330 F=(B-A)*(X-1)/(P1-1)+A
6340 GOSUB 6490
6350 NEXT X
6360 PRINTER IS 16
6370 GOTO 320 ! RETURN
6380 !
6390 ! Formatting
6400 !
6410 PRINT " Frequency Insertion Max Ins Min Ins Max Unc Min
Unc"
6420 PRINT " (GHz) (dB) (dB) (dB) (dB) (d
B)"
6430 PRINT "
"
6440 RETURN
6450 PRINT " Frequency Return Max Ret Min Ret Uncer S22
"
6460 PRINT " (GHz) (dB) (dB) (dB) (dB) dB

```

```

>"
6470 PRINT " _____
"
6480 RETURN
6490 IMAGE 6X, DD, DD, 5X, 4D, DD, 5X, 4D, DD, 4X, 4D, DD, 4X, 4D, DD, 4X, 4D, DD
6500 PRINT USING 6490; F, R19(X), R4(X), R5(X), R3(X), R6(X)
6510 RETURN
6520 PRINT USING 6490; F, R11(X), R12(X), R16(X), R12(X)-R11(X), R16(X)-R11(X)
6530 RETURN
6540 !
6550 ! -----
6560 !         DEVICE DEPENDENT
6570 !         SUBROUTINES
6580 ! -----
6590 !
6600 !         <8756 READ ROUTINE>
6610 !
6620 SHORT D1(401), D2(401), D3(401)
6630 F1=0
6640 F2=0
6650 OUTPUT A0; "C1"
6660 OUTPUT A0; "SD5"
6670 OUTPUT A0; "RL0"
6680 IF (F1=1) OR (F2=1) THEN GOTO 6700
6690 WAIT 2000
6700 WAIT 1000
6710 OUTPUT A0; "SM"
6720 OUTPUT A0; "FD0"
6730 OUTPUT A0; "OM"
6740 IF F1=1 THEN RETURN
6750 IF F2=1 THEN RETURN
6760 ENTER A0 USING "F"; D1(*)
6770 !
6780 ! *** UPPER TEST FREQUENCY REACHED? ***
6790 !
6800 IF S2=B THEN GOTO 7130
6810 !
6820 ! *** IF NOT THEN GOTO NEXT BAND ***
6830 !
6840 GOSUB 7460
6850 F1=1
6860 GOSUB 6650
6870 ENTER A0 USING "F"; D2(*)
6880 F1=0
6890 !
6900 ! *** UPPER FREQUENCY REACHED? ***
6910 !
6920 IF S2=B THEN GOTO 7170
6930 !
6940 ! *** IF NOT THEN NEXT BAND ***
6950 !
6960 GOSUB 7460
6970 F2=1
6980 GOSUB 6650
6990 ENTER A0 USING "F"; D3(*)
7000 F2=0
7010 Y=1
7020 FOR X=1 TO 401
7030 IF Y>802 THEN GOTO 7090
7040 IF Y>401 THEN GOTO 7070
7050 D(X)=D1(Y)
7060 GOTO 7100
7070 D(X)=D2(Y-401)
7080 GOTO 7100
7090 D(X)=D3(Y-802)
7100 Y=Y+3

```

```

7110 NEXT X
7120 RETURN
7130 FOR X=1 TO 401
7140 D(X)=D1(X)
7150 NEXT X
7160 RETURN
7170 Y=1
7180 FOR X=1 TO 401
7190 IF Y>401 THEN GOTO 7220
7200 D(X)=D1(Y)
7210 GOTO 7230
7220 D(X)=D2(Y-401)
7230 Y=Y+2
7240 NEXT X
7250 RETURN
7260 !
7270 ! <8350 SETUP ROUTINE>
7280 !
7290 ! *** SET UP INITIAL FREQUENCY BAND ***
7300 !
7310 S1=A
7320 IF (A<70) AND (B>=70) THEN GOTO 7390
7330 IF (A>=70) AND (A<80) AND (B>=80) THEN GOTO 7410
7340 !
7350 ! *** SWEEP FIRST SET OF FREQUENCIES ***
7360 !
7370 S2=B
7380 GOTO 7520
7390 S2=70
7400 GOTO 7520
7410 S2=80
7420 GOTO 7520
7430 !
7440 ! *** SET UP NEXT SWEEP ***
7450 !
7460 S1=S2
7470 IF S2+10>B THEN GOTO 7370
7480 S2=S2+10
7490 !
7500 ! <SET FREQUENCY>
7510 !
7520 IMAGE "FA",DD.DDD,"G2FB",DD.DDD,"G2"
7530 IMAGE "ST",DDDDD,"MS"
7540 OUTPUT S0;"IPMD1"
7550 OUTPUT S0 USING 7520;S1,S2
7560 OUTPUT S0 USING 7530;C
7570 RETURN
7580 !
7590 ! -----
7590 ! DISK DRIVER OR CASSETE IN THE SYSTEM
7600 !
7610 ! DISK OR CASSETTE STORAGE SUBROUTINE
7620 PRINT PAGE
7630 DISP "ENTER C FOR CASSETTE STORAGE, D FOR DISK STORAGE";
7640 INPUT B$
7650 IF (B$<>"C") AND (B$<>"D") THEN GOTO 7630
7660 IF B$="C" THEN B$=":T15"
7670 IF B$="D" THEN B$=":F"
7680 DISP "ENTER FILE NAME";
7690 INPUT F$
7700 PRINT PAGE
7710 F$=F$&B$
7720 CREATE F$,1010,120
7730 ASSIGN #1 TO F$
7740 PRINT #1;N$,A,B,P,M3,M6,M7,M8,M9
7750 FOR X=1 TO 401 STEP P
7760 F=(B-A)*(X-1)/(P1-1)+A

```



```

7770 R6(X)=ABS(10^(R1(X)/20)-10^(R2(X)/20))/(10^(R1(X)/20)+10^(R2(X)/20)
7780 IF R6(X)=0 THEN GOTO 7800
7790 R6(X)=20*LGT(R6(X))
7800 !
7810 PRINT #1;F,R(X),R4(X),R5(X),R3(X),R11(X),R12(X),R16(X),R10(X),R13(X),R14(X)
,R17(X),R6(X)
7820 NEXT X
7830 GOTO 320
7840 ! DISK OR CASSETTE DATA RETRIEVAL SUBROUTINE
7850 PRINT PAGE
7860 DISP "ENTER C FOR CASSETTE READ , D FOR DISK READ";
7870 INPUT B$
7880 IF (B$<>"C") AND (B$<>"D") THEN GOTO 7860
7890 IF B$="D" THEN B$=":F"
7900 IF B$="C" THEN B$=":T15"
7910 DISP "ENTER FILE NAME ";
7920 INPUT F$
7930 F$=F$&B$
7940 ASSIGN #1 TO F$
7950 READ #1;N$,A,B,P,M3,M6,M7,M8,M9
7960 FOR X=1 TO 401 STEP P
7970 READ #1;F,R(X),R4(X),R5(X),R3(X),R11(X),R12(X),R16(X),R10(X),R13(X),R14(X)
,R17(X),R6(X)
7980 NEXT X
7990 GOTO 320
8000 ! -----
8010 ! DISPLAY or PRINT the INTERMEDIATE VALUES
8020 ! -----
8030 ! <Intermediate values for INSERTION>
8040 PRINT PAGE
8050 A$="X"
8060 INPUT "Do you want results printed ? (enter 'Y' for printout)",A$
8070 IF A$="Y" THEN GOTO 8360
8080 !
8090 ! PRINT TO DISPLAY
8100 !
8110 FOR Y=0 TO P1-1 STEP 11*P
8120 PRINT PAGE
8130 PRINT "DEVICE UNDER TEST : ",N$
8140 PRINT
8150 PRINT
8160 PRINT
8170 PRINT " F S21 S12 S11 S22 GAMMA-S GAMMA-L
Avg "
8180 PRINT "
"
8190 PRINT
8200 FOR W=1 TO 11*P STEP P
8210 X=Y+W
8220 IF X>P1 THEN GOTO 8270
8230 F=(B-A)*(X-1)/(P1-1)+A
8240 Z=10^(R11(X)/20)
8250 PRINT USING 8310;F,Z,R10(X),R17(X),R6(X),R14(X),R13(X),R15(X)
8260 NEXT W
8270 DISP "Press CONT . . ."
8280 PAUSE
8290 DISP
8300 NEXT Y
8310 IMAGE X,DD.DD,4X,DD.DD,4X,DD.DD,4X,DD.DD,4X,DD.DD,5X,DD.DD,5X,DD.DD,5X,DD.
DD
8320 GOTO 320
8330 !
8340 ! PRINT TO PRINTER
8350 !
8360 PRINTER IS 0
8370 PRINT

```

```

9390 PRINT "Device under test : ";N$
9390 PRINT
9400 PRINT
9410 PRINT " F          S21          S12          S11          S22          GAMMA-S'  GAMMA-L'
Aug
8420 PRINT "
-----
8430 FOR X=1 TO P1 STEP P
8440 F=(B-A)*(X-1)/(P1-1)+A
8450 Z=10^(R11(X)/20)
8460 PRINT USING 9310;F,Z,R10(X),R17(X),R6(X),R14(X),R13(X),R15(X)
8470 NEXT X
8480 PRINTER IS 16
8490 GOTO 320
8500 | <Intermediate values for RETURN>
8510 PRINT PAGE
8520 A$="X"
8530 INPUT "Do you want results printed ?(enter 'Y' for printout)",A$
8540 IF A$="Y" THEN GOTO 8790
8550 FOR Y=0 TO P1-1 STEP 11*P
8560 PRINT PAGE
8570 PRINT "DEVICE UNDER TEST : ",N$
8580 PRINT
8590 PRINT
8600 PRINT
8610 PRINT " F          R1(X)          R2(X)          R(X)          R6(X) "
8620 PRINT "-----"
8630 PRINT
8640 FOR W=1 TO 11*P STEP P
8650 X=Y+W
8660 IF X>P1 THEN GOTO 8740
8670 F=(B-A)*(X-1)/(P1-1)+A
8680 K=10^(R1(X)/20)
8690 L=10^(R2(X)/20)
8700 R(X)=(K+L)/2
8710 R6(X)=(K-L)/(K+L)
8720 PRINT USING 8770;F,K,L,R(X),R6(X)
8730 NEXT W
8740 DISP "Press CONT . . . . ."
8750 PAUSE
8760 NEXT Y
8770 IMAGE X,DD,DD,4X,DD,DD,4X,DD,DD,4X,DD,DD,4X,DD,DD
8780 GOTO 320
8790 PRINTER IS 0
8800 PRINT
8810 PRINT "Device under test : ";N$
8820 PRINT
8830 PRINT
8840 PRINT " F          R1(X)          R2(X)          R(X)          R6(X) "
8850 PRINT "-----"
8860 FOR X=1 TO P1 STEP P
8870 F=(B-A)*(X-1)/(P1-1)+A
8880 K=10^(R1(X)/20)
8890 L=10^(R2(X)/20)
8900 R(X)=(K+L)/2
8910 R6(X)=(K-L)/(K+L)
8920 PRINT USING 8770;F,K,L,R(X),R6(X)
8930 NEXT X
8940 PRINTER IS 16
8950 GOTO 320
8960 |
8970 | *** PLOT RETURN LOSS ON 9872C PLOTTER ***
8980 |
8990 PLOTTER IS 7,5,"9872A"
9000 LIMIT 37,240,57,171
9010 GOSUB 4560

```

```
9020 GOSUB 4440
9030 GOSUB 5230
9040 PEN 3
9050 GOSUB 5300
9060 GOSUB 5350
9070 PEN 0
9080 EXIT GRAPHICS
9090 RETURN
9100 |
9110 | *** PLOT INSERTION LOSS ON 9872C ***
9120 |
9130 PLOTTER IS 7,5,"9872A"
9140 LIMIT 37,240,57,171
9150 GOSUB 4560
9160 GOSUB 4440
9170 GOSUB 5570
9180 PEN 3
9190 GOSUB 5620
9200 GOSUB 5670
9210 PEN 0
9220 EXIT GRAPHICS
9230 RETURN
9240 END
```

APPENDIX C

TABULAR DATA OF MEASUREMENTS USING SCHOTTKY BARRIER DIODE DETECTOR

Tabular data for the calibration and system accuracy of the Automated Millimeter-Wave Scalar Network Analyzer using the Schottky Barrier Diode Detector are contained in this Appendix. An explanation of this data can be found in Chapter III.

TABLE II
 PRINTED OUTPUT OF FIXED SHORT RETURN LOSS USING SCHOTTKY
 DIODE DETECTOR

DEVICE UNDER TEST : FIXED SHORT

Frequency (GHz)	Return (dB)	Max Ret (dB)	Min Ret (dB)	Uncer (dB)	S22 (dB)
60.00	-.31	.69	-1.44	-18.55	-18.70
60.15	-.74	.34	-1.98	-18.31	-17.57
60.30	1.18	2.67	-.61	-13.40	-16.18
60.45	-.41	.66	-1.62	-18.11	-18.03
60.60	-.94	-.10	-1.87	-20.84	-19.98
60.75	1.02	2.39	-.60	-14.35	-16.86
60.90	.04	1.45	-1.64	-15.04	-15.63
61.05	-1.54	-.40	-2.84	-18.65	-16.35
61.20	-.79	.32	-2.07	-18.07	-17.20
61.35	1.12	2.49	-.52	-14.21	-16.90
61.50	-.56	.71	-2.04	-16.65	-16.14
61.65	-1.43	-.31	-2.72	-18.67	-16.59
61.80	.51	1.71	-.89	-16.04	-17.62
61.95	-.07	.93	-1.20	-18.34	-18.96
62.10	-1.13	-.18	-2.20	-19.87	-18.51
62.25	.16	1.37	-1.25	-16.34	-17.25
62.40	.57	1.53	-.52	-18.04	-19.90
62.55	-.92	-.09	-1.85	-20.82	-19.98
62.70	-.12	.92	-1.29	-18.07	-18.56
62.85	.70	1.65	-.37	-18.02	-20.14
63.00	-.66	.05	-1.43	-22.06	-21.92
63.15	.42	1.38	-.66	-18.26	-19.84
63.30	.20	.93	-.60	-20.91	-22.34
63.45	-.20	.24	-.67	-25.88	-27.28
63.60	.55	1.19	-.13	-21.91	-24.17
63.75	.35	1.07	-.44	-20.88	-22.59
63.90	-.42	.18	-1.06	-23.32	-23.86
64.05	-.15	.20	-.51	-27.92	-30.18
64.20	.15	.44	-.14	-29.39	-32.74
64.35	-.02	.39	-.44	-26.42	-28.12
64.50	-.35	.17	-.89	-24.67	-25.61
64.65	-.17	.27	-.63	-25.8	-27.45
64.80	.16	.41	-.10	-30.3	-34.14
64.95	-.06	.25	-.37	-29.05	-31.55
65.10	-.31	.15	-.79	-25.6	-26.84
65.25	-.04	.36	-.46	-26.51	-28.43
65.40	.20	.52	-.13	-28.29	-31.38
65.55	-.02	.23	-.29	-30.60	-34.14
65.70	-.30	.13	-.75	-26.21	-27.60
65.85	.05	.59	-.51	-23.96	-25.56
66.00	.44	1.10	-.27	-21.58	-23.57
66.15	.12	.68	-.47	-23.45	-25.10
66.30	-.33	.05	-.72	-27.37	-29.02
66.45	.11	.60	-.40	-24.69	-26.55
66.60	.37	.97	-.27	-22.57	-24.57
66.75	-.31	.29	-.95	-23.28	-24.84
66.90	-.06	.37	-.52	-25.88	-27.67
67.05	.34	1.05	-.43	-21.02	-22.74
67.20	-.90	-.14	-1.73	-21.70	-21.02
67.35	.01	.78	-.84	-20.59	-21.59
67.50	-1.34	-.27	-2.56	-18.96	-17.89
67.65	-.43	.55	-1.54	-18.88	-18.82
67.80	.55	1.56	-.58	-17.68	-19.48
67.95	.63	1.51	-.35	-18.79	-20.84
68.10	-.61	.25	-1.56	-20.26	-19.98
68.25	-1.14	-.15	-2.26	-19.47	-18.05
68.40	-.69	.15	-1.62	-20.56	-20.17
68.55	.33	1.32	-.79	-18.05	-19.43
68.70	.54	1.27	-.26	-20.60	-22.67
68.85	-.34	.32	-1.06	-22.35	-22.89
69.00	-.74	-.01	-1.53	-21.88	-21.56

REPRODUCED BY GOVERNMENT EXPENSE

TABLE II (cont.)

69.15	.20	1.12	-.83	-18.85	-20.04
69.30	.69	1.59	-.31	-18.60	-20.75
69.45	-.72	.10	-1.63	-20.78	-20.34
69.60	-.78	.18	-1.86	-19.42	-18.72
69.75	.79	2.08	-.72	-15.11	-17.20
69.90	.63	1.94	-.91	-15.16	-16.94
70.05	-.24	.65	-1.24	-19.57	-19.96
70.20	.99	2.05	-.21	-16.79	-19.40
70.35	-.38	.62	-1.52	-18.60	-18.61
70.50	-1.04	-.14	-2.03	-20.35	-19.22
70.65	.27	1.18	-.75	-18.87	-20.20
70.80	.40	1.29	-.59	-18.94	-20.54
70.95	-.82	-.04	-1.69	-21.32	-20.75
71.10	-.30	.46	-1.13	-21.10	-21.55
71.25	.58	1.27	-.17	-21.12	-23.33
71.40	-.22	.54	-1.05	-20.99	-21.59
71.55	-.64	.01	-1.34	-22.05	-22.86
71.70	.01	.61	-.63	-22.93	-24.26
71.85	-.02	.47	-.53	-24.81	-26.43
72.00	-.56	.03	-1.18	-23.74	-24.08
72.15	.11	.93	-.79	-19.97	-21.11
72.30	.56	1.25	-.20	-21.02	-23.16
72.45	-.32	.17	-.84	-25.12	-26.21
72.60	-.23	.22	-.71	-25.69	-27.08
72.75	.32	.82	-.21	-24.23	-26.42
72.90	.25	.74	-.28	-24.36	-26.42
73.05	-.16	.10	-.43	-30.51	-33.74
73.20	-.05	.27	-.18	-31.70	-36.01
73.35	.17	.55	-.22	-26.89	-29.41
73.50	.07	.49	-.38	-26.00	-28.06
73.65	-.23	.14	-.61	-27.51	-29.41
73.80	-.20	.12	-.54	-28.53	-30.82
73.95	-.28	.05	-.62	-28.58	-30.73
74.10	.12	.44	-.21	-28.34	-31.21
74.25	.39	.94	-.20	-23.26	-25.48
74.40	-.11	.58	-.85	-21.85	-22.78
74.55	-.60	.11	-1.37	-21.99	-21.96
74.70	-.54	.18	-1.33	-21.83	-21.89
74.85	.34	.87	-.23	-23.60	-25.71
75.00	-.05	.77	-.96	-20.08	-20.90
75.15	-.96	.01	-2.05	-19.54	-18.49
75.30	-.02	.71	-.83	-21.10	-22.09
75.45	-.10	.42	-.65	-24.26	-25.61
75.60	-.59	.24	-1.52	-20.50	-20.29
75.75	.59	1.39	-.29	-19.75	-21.82
75.90	-.18	.57	-1.01	-21.05	-21.72
76.05	-.75	.12	-1.70	-20.38	-19.85
76.20	.83	1.90	-.40	-16.76	-19.03
76.35	-.55	.50	-1.74	-18.39	-18.05
76.50	-1.03	-.12	-2.06	-20.10	-18.96
76.65	.66	1.76	-.61	-16.70	-18.63
76.80	-1.29	-.18	-2.56	-18.61	-16.81
76.95	-1.01	.07	-2.25	-18.55	-17.29
77.10	.02	.78	-.80	-20.83	-21.89
77.25	.74	1.74	-.40	-17.49	-19.64
77.40	.16	1.15	-.96	-18.19	-19.25
77.55	-.38	.40	-1.22	-21.02	-21.30
77.70	-1.31	-.16	-2.64	-18.28	-16.41
77.85	-1.56	-.32	-3.01	-17.84	-15.42
78.00	-1.32	-.10	-2.73	-17.77	-15.84
78.15	-.82	.25	-2.05	-18.44	-17.55
78.30	-.15	.62	-1.00	-20.78	-21.49
78.45	.65	1.55	-.36	-18.54	-20.60
78.60	.30	1.04	-.52	-20.65	-22.23
78.75	-1.22	-.18	-2.41	-19.11	-17.48
78.90	-.55	.44	-1.66	-18.95	-15.65

TABLE II (cont.)

79.05	.51	1.32	-.38	-19.71	-21.62
79.20	-1.42	-.29	-2.72	-18.56	-16.49
79.35	.32	1.39	-.91	-17.27	-18.56
79.50	.62	1.38	-.22	-20.13	-22.30
79.65	-.45	.20	-1.15	-22.64	-23.01
79.80	-.63	.31	-1.69	-19.45	-19.03
79.95	.35	1.42	-.87	-17.29	-18.65
80.10	-.74	.34	-1.98	-18.31	-17.57
80.25	-.94	-.10	-1.87	-20.84	-19.98
80.40	-1.54	-.40	-2.84	-18.65	-16.35
80.55	-.56	.71	-2.04	-16.65	-16.14
80.70	-.07	.93	-1.20	-18.34	-18.96
80.85	.57	1.53	-.52	-18.04	-19.90
81.00	.70	1.65	-.37	-18.02	-20.14
81.15	.20	.93	-.60	-20.91	-22.34
81.30	.35	1.07	-.44	-20.88	-22.59
81.45	.15	.44	-.14	-29.39	-32.74
81.60	-.17	.27	-.63	-25.89	-27.46
81.75	-.31	.15	-.79	-25.61	-26.84
81.90	-.02	.23	-.29	-30.60	-34.14
82.05	.44	1.10	-.27	-21.58	-23.57
82.20	.11	.60	-.40	-24.69	-26.55
82.35	-.06	.37	-.52	-25.88	-27.67
82.50	.01	.78	-.84	-20.59	-21.59
82.65	.55	1.56	-.58	-17.68	-19.48
82.80	-1.14	-.15	-2.26	-19.47	-18.05
82.95	.54	1.27	-.26	-20.60	-22.67
83.10	.20	1.12	-.83	-18.85	-20.04
83.25	-.78	.18	-1.86	-19.42	-18.72
83.40	-.24	.65	-1.24	-19.57	-19.96
83.55	-1.04	-.14	-2.03	-20.35	-19.22
83.70	-.82	-.04	-1.69	-21.32	-20.75
83.85	-.22	.54	-1.05	-20.99	-21.59
84.00	-.02	.47	-.53	-24.81	-26.43
84.15	.56	1.25	-.20	-21.02	-23.16
84.30	.32	.82	-.21	-24.23	-26.42
84.45	.05	.27	-.18	-31.70	-36.01
84.60	-.23	.14	-.61	-27.51	-29.41
84.75	.12	.44	-.21	-28.34	-31.21
84.90	-.60	.11	-1.37	-21.99	-21.96
85.05	-.05	.77	-.96	-20.08	-20.90
85.20	-.10	.42	-.65	-24.26	-25.61
85.35	-.18	.57	-1.01	-21.05	-21.72
85.50	-.55	.50	-1.74	-18.39	-18.05
85.65	-1.29	-.18	-2.56	-18.61	-16.91
85.80	.74	1.74	-.40	-17.49	-19.64
85.95	-1.31	-.16	-2.64	-18.28	-16.41
86.10	-.82	.25	-2.05	-18.44	-17.55
86.25	.30	1.04	-.52	-20.65	-22.23
86.40	.51	1.32	-.38	-19.71	-21.62
86.55	.62	1.38	-.22	-20.13	-22.30
86.70	.35	1.42	-.87	-17.29	-18.65
86.85	-1.54	-.40	-2.84	-18.65	-16.35
87.00	.57	1.53	-.52	-18.04	-19.90
87.15	.35	1.07	-.44	-20.88	-22.59
87.30	-.31	.15	-.79	-25.61	-26.84
87.45	.11	.60	-.40	-24.69	-26.55
87.60	.55	1.56	-.58	-17.68	-19.48
87.75	.20	1.12	-.83	-18.85	-20.04
87.90	-1.04	-.14	-2.03	-20.35	-19.22
88.05	-.02	.47	-.53	-24.81	-26.43
88.20	.05	.27	-.18	-31.70	-36.01
88.35	-.60	.11	-1.37	-21.99	-21.96
88.50	-.18	.57	-1.01	-21.05	-21.72
88.65	.74	1.74	-.40	-17.49	-19.64
88.80	.30	1.04	-.52	-20.65	-22.23

TABLE II (cont.)

88.95	.35	1.42	-.87	-17.29	-18.65
89.10	.35	1.07	-.44	-20.88	-22.59
89.25	.55	1.56	-.58	-17.68	-19.48
89.40	-.02	.47	-.53	-24.81	-26.43
89.55	-.18	.57	-1.01	-21.05	-21.72
89.70	.35	1.42	-.87	-17.29	-18.65
89.85	-.02	.47	-.53	-24.81	-26.43
90.00	-.02	.47	-.53	-24.81	-26.43

REPRODUCED AT GOVERNMENT EXPENSE

TABLE III
 PRINTED OUTPUT OF MATCHED LOAD RETURN LOSS USING SCHOTTKY
 DIODE DETECTOR
 DEVICE UNDER TEST : MATCHED LOAD

Frequency (GHz)	Return (dB)	Max Ret (dB)	Min Ret (dB)	Uncer (dB)	S22 (dB)
60.00	-25.13	-23.64	-26.93	-39.70	-18.70
60.15	-25.22	-23.71	-27.05	-39.66	-17.57
60.30	-25.91	-24.29	-27.91	-39.66	-16.18
60.45	-27.95	-25.98	-30.51	-39.83	-18.03
60.60	-30.79	-28.19	-34.52	-39.93	-19.98
60.75	-31.62	-28.00	-35.85	-39.91	-16.86
60.90	-33.02	-29.78	-38.24	-39.93	-15.63
61.05	-30.63	-28.06	-34.30	-39.89	-16.35
61.20	-31.15	-28.45	-35.09	-39.91	-17.20
61.35	-29.78	-27.41	-33.04	-39.87	-16.90
61.50	-32.38	-29.33	-37.10	-39.92	-16.14
61.65	-31.44	-28.66	-35.55	-39.91	-16.59
61.80	-33.32	-29.99	-38.77	-39.95	-17.62
61.95	-34.07	-30.50	-40.21	-39.96	-18.96
62.10	-30.88	-28.25	-34.67	-39.92	-18.51
62.25	-31.30	-28.56	-35.33	-39.91	-17.25
62.40	-31.22	-28.50	-35.18	-39.93	-19.90
62.55	-31.05	-28.38	-34.93	-39.93	-19.98
62.70	-31.72	-28.87	-36.00	-39.93	-18.56
62.85	-33.30	-29.99	-38.73	-39.96	-20.14
63.00	-34.19	-30.59	-40.46	-39.97	-21.92
63.15	-34.34	-30.69	-40.78	-39.97	-19.84
63.30	-29.25	-27.02	-32.26	-39.92	-22.34
63.45	-27.81	-25.89	-30.28	-39.94	-27.28
63.60	-26.55	-24.85	-28.66	-39.88	-24.17
63.75	-26.74	-25.01	-28.91	-39.86	-22.59
63.90	-27.32	-25.48	-29.64	-39.90	-23.86
64.05	-27.69	-25.80	-30.12	-39.95	-30.10
64.20	-28.86	-26.73	-31.69	-39.97	-32.74
64.35	-29.88	-27.51	-33.14	-39.97	-28.42
64.50	-30.51	-27.99	-34.08	-39.96	-25.61
64.65	-32.53	-29.46	-37.33	-39.98	-27.46
64.80	-33.79	-30.33	-39.63	-39.99	-34.14
64.95	-38.36	-33.12	-53.66	-40.00	-31.83
65.10	-35.13	-31.20	-42.49	-39.99	-26.84
65.25	-36.02	-31.76	-44.72	-39.99	-28.49
65.40	-35.11	-31.19	-42.44	-39.99	-31.30
65.55	-33.77	-30.31	-39.59	-39.99	-34.14
65.70	-34.84	-31.02	-41.83	-39.99	-27.60
65.85	-36.91	-32.30	-47.42	-39.99	-25.56
66.00	-40.25	-34.10	-120.00	-39.99	-23.57
66.15	-41.02	-34.47	-120.00	-40.00	-25.10
66.30	-39.84	-33.90	-74.68	-40.00	-29.02
66.45	-36.84	-32.26	-47.19	-39.99	-26.55
66.60	-40.34	-34.14	-120.00	-40.00	-24.57
66.75	-36.65	-32.14	-46.57	-39.99	-24.04
66.90	-41.34	-34.62	-120.00	-40.00	-27.67
67.05	-34.28	-30.65	-40.64	-39.98	-22.74
67.20	-34.16	-30.57	-40.39	-39.97	-21.02
67.35	-32.23	-29.24	-36.83	-39.96	-21.59
67.50	-32.52	-29.44	-37.34	-39.93	-17.09
67.65	-31.64	-28.81	-35.86	-39.93	-18.82
67.80	-31.70	-28.86	-35.95	-39.94	-19.48
67.95	-31.28	-28.55	-35.27	-39.94	-20.84
68.10	-31.02	-28.36	-34.87	-39.93	-19.98
68.25	-31.49	-28.70	-35.63	-39.92	-18.05
68.40	-32.52	-29.44	-37.32	-39.95	-20.17
68.55	-32.68	-29.55	-37.60	-39.95	-19.43
68.70	-34.04	-30.49	-40.14	-39.97	-22.67
68.85	-37.98	-32.91	-51.67	-39.99	-22.89
69.00	-36.49	-32.04	-46.09	-39.98	-21.56

TABLE III (cont.)

69.15	-33.17	-29.90	-38.49	-39.96	-20.04
69.30	-31.53	-28.74	-35.68	-39.94	-20.75
69.45	-30.45	-27.93	-34.00	-39.93	-20.34
69.60	-29.75	-27.40	-32.99	-39.89	-18.72
69.75	-28.83	-26.67	-31.70	-39.84	-17.20
69.90	-29.71	-27.36	-32.93	-39.87	-16.94
70.05	-29.11	-26.91	-32.07	-39.89	-19.96
70.20	-32.20	-29.22	-36.79	-39.94	-19.40
70.35	-34.76	-30.96	-41.68	-39.97	-18.61
70.50	-30.66	-33.28	-55.65	-39.99	-19.22
70.65	-39.44	-33.69	-63.60	-39.99	-20.20
70.80	-35.79	-31.61	-44.13	-39.98	-20.54
70.95	-33.54	-30.15	-39.17	-39.96	-20.75
71.10	-31.87	-28.98	-36.22	-39.95	-21.55
71.25	-32.33	-29.32	-36.99	-39.97	-23.33
71.40	-32.96	-29.76	-38.10	-39.96	-21.59
71.55	-36.98	-32.33	-47.66	-39.99	-22.86
71.70	-39.42	-33.68	-63.30	-39.99	-24.26
71.85	-35.12	-31.20	-42.47	-39.99	-25.43
72.00	-30.20	-27.75	-33.63	-39.95	-24.08
72.15	-28.90	-26.74	-31.77	-39.90	-21.11
72.30	-28.44	-26.39	-31.14	-39.91	-23.16
72.45	-28.90	-26.75	-31.75	-39.95	-26.21
72.60	-29.54	-27.25	-32.66	-39.96	-27.08
72.75	-31.12	-28.44	-35.01	-39.97	-26.42
72.90	-31.98	-29.07	-36.40	-39.97	-26.42
73.05	-32.49	-29.43	-37.24	-39.99	-33.74
73.20	-31.04	-28.39	-34.88	-39.99	-36.01
73.35	-31.11	-28.44	-34.99	-39.98	-29.41
73.50	-32.25	-29.26	-36.84	-39.98	-28.06
73.65	-32.84	-29.67	-37.86	-39.98	-29.41
73.80	-33.03	-29.81	-38.21	-39.99	-30.82
73.95	-36.10	-31.81	-44.93	-39.99	-30.73
74.10	-38.11	-32.98	-52.29	-40.00	-31.21
74.25	-38.57	-33.23	-54.95	-39.99	-25.40
74.40	-38.94	-33.43	-57.83	-39.99	-22.78
74.55	-34.69	-30.92	-41.51	-39.98	-21.96
74.70	-34.61	-30.87	-41.34	-39.98	-21.89
74.85	-32.08	-29.14	-36.57	-39.97	-25.71
75.00	-31.25	-28.53	-35.23	-39.94	-20.90
75.15	-29.95	-27.55	-33.28	-39.90	-18.49
75.30	-31.64	-28.82	-35.85	-39.95	-22.09
75.45	-33.66	-30.24	-39.40	-39.98	-25.61
75.60	-41.22	-34.56	-120.00	-39.99	-20.29
75.75	-41.19	-34.55	-120.00	-39.99	-21.82
75.90	-41.39	-34.65	-120.00	-39.99	-21.72
76.05	-42.80	-35.26	-120.00	-40.00	-19.85
76.20	-40.70	-34.32	-120.00	-39.99	-19.03
76.35	-38.74	-33.32	-56.20	-39.99	-18.05
76.50	-35.89	-31.67	-44.40	-39.97	-18.96
76.65	-32.42	-29.37	-37.15	-39.94	-18.63
76.80	-32.47	-29.40	-37.26	-39.93	-16.81
76.95	-32.80	-29.64	-37.84	-39.94	-17.29
77.10	-32.53	-29.45	-37.34	-39.96	-21.89
77.25	-32.71	-29.58	-37.67	-39.95	-19.64
77.40	-32.13	-29.17	-36.67	-39.94	-19.25
77.55	-32.07	-29.13	-36.56	-39.95	-21.30
77.70	-32.06	-29.11	-36.56	-39.92	-16.41
77.85	-32.17	-29.18	-36.75	-39.91	-15.42
78.00	-32.17	-29.19	-36.75	-39.92	-15.84
78.15	-31.69	-28.84	-35.94	-39.92	-17.55
78.30	-32.21	-29.23	-36.79	-39.96	-21.49
78.45	-31.41	-28.65	-35.49	-39.94	-20.60
78.60	-32.37	-29.34	-37.07	-39.96	-22.23
78.75	-32.83	-29.65	-37.88	-39.94	-17.48
78.90	-33.52	-30.14	-39.15	-39.96	-18.65

TABLE III (cont.)

79.05	-36.98	-32.33	-47.64	-39.99	-21.62
79.20	-36.21	-31.87	-45.31	-39.97	-16.49
79.35	-36.56	-32.08	-46.32	-39.98	-18.56
79.50	-36.17	-31.85	-45.15	-39.98	-22.30
79.65	-34.14	-30.56	-40.35	-39.98	-23.01
79.80	-32.87	-29.69	-37.95	-39.95	-19.03
79.95	-32.54	-29.46	-37.37	-39.94	-18.65
80.10	-25.22	-23.71	-27.05	-39.66	-17.57
80.25	-30.79	-28.19	-34.52	-39.93	-19.98
80.40	-30.63	-28.06	-34.30	-39.89	-16.35
80.55	-32.38	-29.33	-37.10	-39.92	-16.14
80.70	-34.07	-30.50	-40.21	-39.96	-19.96
80.85	-31.22	-28.50	-35.18	-39.93	-19.90
81.00	-33.30	-29.99	-38.73	-39.96	-20.14
81.15	-29.25	-27.02	-32.26	-39.92	-22.34
81.30	-26.74	-25.01	-28.91	-39.86	-22.59
81.45	-28.86	-26.73	-31.69	-39.97	-32.74
81.60	-32.53	-29.46	-37.33	-39.98	-27.46
81.75	-35.13	-31.20	-42.49	-39.99	-26.84
81.90	-33.77	-30.31	-39.59	-39.99	-34.14
82.05	-40.25	-34.10	-120.00	-39.99	-23.57
82.20	-36.84	-32.26	-47.19	-39.99	-26.55
82.35	-41.34	-34.62	-120.00	-40.00	-27.67
82.50	-32.23	-29.24	-36.83	-39.96	-21.59
82.65	-31.70	-28.86	-35.95	-39.94	-19.48
82.80	-31.49	-28.70	-35.63	-39.92	-18.05
82.95	-34.04	-30.49	-40.14	-39.97	-22.67
83.10	-33.17	-29.90	-38.49	-39.96	-20.04
83.25	-29.75	-27.40	-32.99	-39.89	-18.72
83.40	-29.11	-26.91	-32.07	-39.89	-19.96
83.55	-38.66	-33.28	-55.65	-39.99	-19.22
83.70	-33.54	-30.15	-39.17	-39.96	-20.75
83.85	-32.96	-29.76	-38.10	-39.96	-21.59
84.00	-35.12	-31.20	-42.47	-39.99	-26.43
84.15	-28.44	-26.39	-31.14	-39.91	-23.16
84.30	-31.12	-28.44	-35.01	-39.97	-26.42
84.45	-31.04	-28.39	-34.88	-39.99	-36.01
84.60	-32.84	-29.67	-37.86	-39.98	-29.41
84.75	-38.11	-32.98	-52.29	-40.00	-31.21
84.90	-34.69	-30.92	-41.51	-39.98	-21.96
85.05	-31.25	-28.53	-35.23	-39.94	-20.90
85.20	-33.66	-30.24	-39.40	-39.98	-25.61
85.35	-41.39	-34.65	-120.00	-39.99	-21.72
85.50	-38.74	-33.32	-56.20	-39.99	-18.05
85.65	-32.47	-29.40	-37.26	-39.93	-16.31
85.80	-32.71	-29.58	-37.67	-39.95	-19.64
85.95	-32.06	-29.11	-36.56	-39.92	-16.41
86.10	-31.69	-28.84	-35.94	-39.92	-17.55
86.25	-32.37	-29.34	-37.07	-39.96	-22.23
86.40	-36.98	-32.33	-47.64	-39.99	-21.62
86.55	-36.17	-31.85	-45.15	-39.98	-22.30
86.70	-32.54	-29.46	-37.37	-39.94	-18.65
86.85	-30.63	-28.06	-34.30	-39.89	-16.35
87.00	-31.22	-28.50	-35.18	-39.93	-19.90
87.15	-26.74	-25.01	-28.91	-39.86	-22.59
87.30	-35.13	-31.20	-42.49	-39.99	-26.84
87.45	-36.84	-32.26	-47.19	-39.99	-26.55
87.60	-31.70	-28.86	-35.95	-39.94	-19.48
87.75	-33.17	-29.90	-38.49	-39.96	-20.04
87.90	-38.66	-33.28	-55.65	-39.99	-19.22
88.05	-35.12	-31.20	-42.47	-39.99	-26.43
88.20	-31.04	-28.39	-34.88	-39.99	-36.01
88.35	-34.69	-30.92	-41.51	-39.98	-21.96
88.50	-41.39	-34.65	-120.00	-39.99	-21.72
88.65	-32.71	-29.58	-37.67	-39.95	-19.64
88.80	-32.37	-29.34	-37.07	-39.96	-22.23

TABLE III (cont.)

88.95	-32.54	-29.46	-37.37	-39.94	-18.65
89.10	-26.74	-25.01	-28.91	-39.86	-22.59
89.25	-31.70	-28.86	-35.95	-39.94	-19.48
89.40	-35.12	-31.20	-42.47	-39.99	-26.43
89.55	-41.39	-34.65	-128.00	-39.99	-21.72
89.70	-32.54	-29.46	-37.37	-39.94	-18.65
89.85	-35.12	-31.20	-42.47	-39.99	-26.43
90.00	-35.12	-31.20	-42.47	-39.99	-26.43

REPRODUCED AT GOVERNMENT EXPENSE

TABLE IV
PRINTED OUTPUT OF RETURN LOSS FOR 5 dB ATTENUATOR WITH
SHORTED OUTPUT USING SCHOTTKY DIODE DETECTOR

DEVICE UNDER TEST : 5 dB ATTENUATOR WITH SHORT

Frequency (GHz)	Return (dB)	Max Ret (dB)	Min Ret (dB)	Uncer (dB)	S22 (dB)
60.00	-10.86	-10.28	-11.47	-34.18	-18.70
60.15	-12.61	-11.99	-13.27	-35.26	-17.57
60.30	-10.32	-9.65	-11.05	-32.24	-16.18
60.45	-10.64	-10.04	-11.27	-33.62	-18.03
60.60	-10.50	-9.96	-11.07	-34.45	-19.98
60.75	-11.38	-10.74	-12.06	-33.79	-16.86
60.90	-10.83	-10.14	-11.58	-32.52	-15.63
61.05	-10.71	-10.05	-11.42	-32.80	-16.35
61.20	-10.72	-10.09	-11.39	-33.27	-17.20
61.35	-10.83	-10.19	-11.51	-33.23	-16.90
61.50	-12.49	-11.83	-13.21	-34.52	-16.14
61.65	-10.72	-10.07	-11.42	-32.94	-16.59
61.80	-10.58	-9.97	-11.23	-33.35	-17.62
61.95	-10.28	-9.71	-10.88	-33.73	-18.96
62.10	-10.93	-10.35	-11.55	-34.16	-18.51
62.25	-9.87	-9.24	-10.55	-32.34	-17.25
62.40	-10.42	-9.89	-11.00	-34.35	-19.90
62.55	-11.48	-10.94	-12.06	-35.33	-19.98
62.70	-12.31	-11.72	-12.94	-35.42	-18.56
62.85	-11.05	-10.51	-11.61	-35.03	-20.14
63.00	-10.45	-9.97	-10.97	-35.28	-21.92
63.15	-9.82	-9.28	-10.39	-33.71	-19.84
63.30	-11.74	-11.25	-12.27	-36.41	-22.34
63.45	-11.74	-11.32	-12.19	-37.79	-27.28
63.60	-10.36	-9.92	-10.82	-36.09	-24.17
63.75	-9.94	-9.48	-10.43	-35.13	-22.59
63.90	-11.16	-10.70	-11.64	-36.53	-23.36
64.05	-11.67	-11.28	-12.08	-38.32	-30.10
64.20	-11.39	-11.02	-11.78	-38.66	-32.74
64.35	-10.66	-10.27	-11.06	-37.55	-28.42
64.50	-10.07	-9.66	-10.50	-36.38	-25.61
64.65	-10.48	-10.09	-10.89	-37.21	-27.46
64.80	-11.14	-10.79	-11.51	-38.78	-34.14
64.95	-11.84	-11.45	-12.24	-38.65	-31.83
65.10	-11.77	-11.34	-12.22	-37.70	-26.84
65.25	-11.23	-10.83	-11.64	-37.83	-28.49
65.40	-10.65	-10.30	-11.03	-38.17	-31.30
65.55	-10.41	-10.07	-10.75	-38.57	-34.14
65.70	-11.02	-10.62	-11.44	-37.52	-27.60
65.85	-11.26	-10.83	-11.72	-37.11	-25.56
66.00	-11.36	-10.90	-11.85	-36.57	-23.57
66.15	-12.09	-11.63	-12.57	-37.43	-25.10
66.30	-12.61	-12.18	-13.07	-38.46	-29.02
66.45	-11.81	-11.38	-12.27	-37.65	-26.55
66.60	-10.68	-10.24	-11.13	-36.44	-24.57
66.75	-10.44	-10.00	-10.91	-36.09	-24.04
66.90	-11.25	-10.85	-11.68	-37.66	-27.67
67.05	-12.45	-11.95	-12.98	-36.99	-22.74
67.20	-11.24	-10.73	-11.79	-35.55	-21.02
67.35	-10.94	-10.44	-11.47	-35.54	-21.59
67.50	-12.22	-11.59	-12.90	-34.71	-17.09
67.65	-11.77	-11.19	-12.38	-35.08	-18.82
67.80	-11.44	-10.89	-12.03	-35.08	-19.48
67.95	-11.22	-10.70	-11.76	-35.46	-20.84
68.10	-11.15	-10.61	-11.72	-35.04	-19.98
68.25	-10.99	-10.40	-11.63	-33.99	-18.05
68.40	-11.77	-11.23	-12.34	-35.64	-20.17
68.55	-12.18	-11.62	-12.78	-35.67	-19.43
68.70	-11.39	-11.40	-12.41	-36.62	-22.67
68.85	-12.08	-11.59	-12.60	-36.91	-22.89
69.00	-12.43	-11.91	-12.99	-36.61	-21.56

TABLE IV (cont.)

69.15	-11.89	-11.34	-12.47	-35.68	-20.04
69.30	-11.51	-10.99	-12.07	-35.67	-20.75
69.45	-11.34	-10.81	-11.90	-35.36	-20.34
69.60	-12.12	-11.54	-12.74	-35.33	-18.72
69.75	-12.20	-11.57	-12.87	-34.74	-17.20
69.90	-11.53	-10.90	-12.22	-33.98	-16.94
70.05	-10.76	-10.22	-11.33	-34.69	-19.96
70.20	-10.98	-10.43	-11.57	-34.64	-19.40
70.35	-9.95	-9.37	-10.57	-33.20	-18.61
70.50	-10.09	-9.53	-10.69	-33.68	-19.22
70.65	-10.81	-10.28	-11.37	-34.84	-20.20
70.80	-10.83	-10.31	-11.38	-35.01	-20.54
70.95	-10.89	-10.37	-11.44	-35.15	-20.75
71.10	-10.23	-9.74	-10.75	-34.93	-21.55
71.25	-11.00	-10.53	-11.48	-36.24	-23.33
71.40	-10.70	-10.21	-11.23	-35.35	-21.59
71.55	-10.58	-10.11	-11.07	-35.76	-22.86
71.70	-11.19	-10.74	-11.66	-36.68	-24.26
71.85	-11.03	-10.61	-11.46	-37.23	-26.43
72.00	-9.93	-9.50	-10.39	-35.73	-24.08
72.15	-10.63	-10.13	-11.17	-35.09	-21.11
72.30	-12.08	-11.59	-12.59	-36.89	-23.16
72.45	-11.48	-11.05	-11.93	-37.41	-26.21
72.60	-11.00	-10.59	-11.42	-37.38	-27.08
72.75	-10.76	-10.35	-11.19	-37.07	-26.42
72.90	-10.78	-10.37	-11.22	-37.09	-26.42
73.05	-10.79	-10.44	-11.15	-38.63	-33.74
73.20	-10.92	-10.58	-11.27	-38.95	-36.01
73.35	-10.82	-10.44	-11.21	-37.85	-29.41
73.50	-10.82	-10.43	-11.23	-37.54	-28.06
73.65	-11.17	-10.78	-11.57	-38.00	-29.41
73.80	-11.36	-10.98	-11.75	-38.34	-30.82
73.95	-11.32	-10.94	-11.72	-38.31	-30.73
74.10	-10.98	-10.61	-11.36	-38.27	-31.21
74.25	-10.86	-10.44	-11.31	-36.83	-25.40
74.40	-11.09	-10.61	-11.59	-36.11	-22.78
74.55	-11.04	-10.55	-11.56	-35.77	-21.96
74.70	-11.19	-10.70	-11.72	-35.86	-21.89
74.85	-11.06	-10.64	-11.51	-37.04	-25.71
75.00	-11.20	-10.68	-11.75	-35.47	-20.90
75.15	-11.53	-10.95	-12.15	-34.72	-18.49
75.30	-10.48	-10.00	-10.99	-35.37	-22.09
75.45	-10.59	-10.17	-11.03	-36.73	-25.61
75.60	-11.94	-11.40	-12.51	-35.81	-20.29
75.75	-11.58	-11.08	-12.11	-36.12	-21.82
75.90	-11.03	-10.53	-11.55	-35.66	-21.72
76.05	-10.75	-10.21	-11.32	-34.63	-19.85
76.20	-11.47	-10.90	-12.07	-34.91	-19.03
76.35	-11.64	-11.04	-12.28	-34.62	-18.05
76.50	-11.49	-10.92	-12.09	-34.89	-18.96
76.65	-11.32	-10.75	-11.94	-34.59	-18.63
76.80	-12.23	-11.59	-12.91	-34.59	-16.81
76.95	-11.73	-11.11	-12.39	-34.34	-17.29
77.10	-11.64	-11.14	-12.17	-36.19	-21.89
77.25	-11.81	-11.25	-12.40	-35.45	-19.64
77.40	-11.79	-11.22	-12.39	-35.20	-19.25
77.55	-11.37	-10.86	-11.91	-35.77	-21.30
77.70	-11.50	-10.85	-12.21	-33.68	-16.41
77.85	-11.84	-11.15	-12.58	-33.51	-15.42
78.00	-12.37	-11.70	-13.10	-34.27	-15.84
78.15	-12.74	-12.12	-13.41	-35.36	-17.55
78.30	-12.82	-12.29	-13.39	-36.83	-21.49
78.45	-12.20	-11.66	-12.77	-36.12	-20.60
78.60	-11.72	-11.23	-12.25	-36.36	-22.23
78.75	-11.85	-11.24	-12.51	-34.55	-17.48
78.90	-11.62	-11.04	-12.24	-34.87	-18.65

REPRODUCED AT GOVERNMENT EXPENSE

TABLE IV (cont.)

79.05	-12.53	-12.01	-13.09	-36.69	-21.62
79.20	-12.48	-11.83	-13.19	-34.68	-16.49
79.35	-11.87	-11.29	-12.49	-35.05	-18.56
79.50	-11.69	-11.19	-12.21	-36.36	-22.30
79.65	-11.82	-11.33	-12.33	-36.68	-23.01
79.80	-11.63	-11.06	-12.24	-35.05	-19.03
79.95	-11.82	-11.24	-12.44	-35.05	-18.65
80.10	-12.61	-11.99	-13.27	-35.26	-17.57
80.25	-10.50	-9.96	-11.07	-34.45	-19.98
80.40	-10.71	-10.05	-11.42	-32.80	-16.35
80.55	-12.49	-11.83	-13.21	-34.52	-16.14
80.70	-10.20	-9.71	-10.88	-33.73	-18.96
80.85	-10.42	-9.89	-11.00	-34.35	-19.90
81.00	-11.05	-10.51	-11.61	-35.03	-20.14
81.15	-11.74	-11.25	-12.27	-36.41	-22.34
81.30	-9.94	-9.48	-10.43	-35.13	-22.59
81.45	-11.39	-11.02	-11.78	-38.66	-32.74
81.60	-10.48	-10.09	-10.89	-37.21	-27.46
81.75	-11.77	-11.34	-12.22	-37.70	-26.84
81.90	-10.41	-10.07	-10.75	-38.57	-34.14
82.05	-11.36	-10.98	-11.85	-36.57	-23.57
82.20	-11.81	-11.38	-12.27	-37.65	-26.55
82.35	-11.25	-10.85	-11.68	-37.66	-27.67
82.50	-10.94	-10.44	-11.47	-35.54	-21.59
82.65	-11.44	-10.89	-12.03	-35.08	-19.48
82.80	-10.99	-10.40	-11.63	-33.99	-18.05
82.95	-11.89	-11.40	-12.41	-36.62	-22.67
83.10	-11.89	-11.34	-12.47	-35.68	-20.84
83.25	-12.12	-11.54	-12.74	-35.33	-18.72
83.40	-10.76	-10.22	-11.33	-34.69	-19.96
83.55	-10.89	-9.53	-10.69	-33.68	-19.22
83.70	-10.89	-10.37	-11.44	-35.15	-20.75
83.85	-10.70	-10.21	-11.23	-35.35	-21.59
84.00	-11.03	-10.61	-11.46	-37.23	-26.43
84.15	-12.08	-11.59	-12.59	-36.89	-23.16
84.30	-10.76	-10.35	-11.19	-37.07	-26.42
84.45	-10.92	-10.58	-11.27	-38.95	-36.81
84.60	-11.17	-10.78	-11.57	-38.00	-29.41
84.75	-10.98	-10.61	-11.36	-38.27	-31.21
84.90	-11.04	-10.55	-11.56	-35.77	-21.96
85.05	-11.20	-10.68	-11.75	-35.47	-20.90
85.20	-10.59	-10.17	-11.03	-36.73	-25.61
85.35	-11.03	-10.53	-11.55	-35.66	-21.72
85.50	-11.64	-11.04	-12.28	-34.62	-18.05
85.65	-12.23	-11.59	-12.91	-34.59	-16.81
85.80	-11.81	-11.25	-12.40	-35.45	-19.64
85.95	-11.50	-10.85	-12.21	-33.68	-16.41
86.10	-12.74	-12.12	-13.41	-35.36	-17.55
86.25	-11.72	-11.23	-12.25	-36.36	-22.23
86.40	-12.53	-12.01	-13.09	-36.69	-21.62
86.55	-11.69	-11.19	-12.21	-36.36	-22.30
86.70	-11.82	-11.24	-12.44	-35.05	-18.65
86.85	-10.71	-10.05	-11.42	-32.80	-16.35
87.00	-10.42	-9.89	-11.08	-34.35	-19.90
87.15	-9.94	-9.48	-10.43	-35.13	-22.59
87.30	-11.77	-11.34	-12.22	-37.70	-26.84
87.45	-11.81	-11.38	-12.27	-37.65	-26.55
87.60	-11.44	-10.89	-12.03	-35.08	-19.48
87.75	-11.89	-11.34	-12.47	-35.68	-20.84
87.90	-10.09	-9.53	-10.69	-33.68	-19.22
88.05	-11.03	-10.61	-11.46	-37.23	-26.43
88.20	-10.92	-10.58	-11.27	-38.95	-36.81
88.35	-11.04	-10.55	-11.56	-35.77	-21.96
88.50	-11.03	-10.53	-11.55	-35.66	-21.72
88.65	-11.81	-11.25	-12.40	-35.45	-19.64
88.80	-11.72	-11.23	-12.25	-36.36	-22.23

REPRODUCED BY GOVERNMENT EXPENSE

TABLE IV (cont.)

88.95	-11.82	-11.24	-12.44	-35.05	-18.65
89.10	-9.94	-9.48	-10.43	-35.13	-22.59
89.25	-11.44	-10.89	-12.03	-35.08	-19.48
89.40	-11.03	-10.61	-11.46	-37.23	-26.43
89.55	-11.03	-10.53	-11.55	-35.66	-21.72
89.70	-11.82	-11.24	-12.44	-35.05	-18.65
89.85	-11.03	-10.61	-11.46	-37.23	-26.43
90.00	-11.03	-10.61	-11.46	-37.23	-26.43

REPRODUCED AT GOVERNMENT EXPENSE

TABLE V

PRINTED OUTPUT OF RETURN LOSS FOR 10 dB ATTENUATOR WITH
SHORTED OUTPUT USING SCHOTTKY DIODE DETECTOR
DEVICE UNDER TEST : 10 dB ATTENUATOR WITH SHORT

Frequency (GHz)	Return (dB)	Max Ret (dB)	Min Ret (dB)	Uncer (dB)	S22 (dB)
60.00	-18.11	-17.32	-18.97	-38.57	-18.70
60.15	-25.41	-23.88	-27.28	-39.68	-17.57
60.30	-19.82	-18.88	-20.87	-38.70	-16.18
60.45	-19.77	-18.86	-20.79	-38.92	-18.03
60.60	-21.07	-20.07	-22.20	-39.35	-19.98
60.75	-20.77	-19.77	-21.90	-39.01	-16.86
60.90	-20.27	-19.29	-21.37	-38.74	-15.63
61.05	-19.51	-18.60	-20.53	-38.63	-16.35
61.20	-19.25	-18.37	-20.23	-38.69	-17.20
61.35	-21.07	-20.04	-22.24	-39.08	-16.90
61.50	-26.43	-24.73	-28.56	-39.70	-16.14
61.65	-20.60	-19.61	-21.72	-38.95	-16.59
61.80	-18.71	-17.87	-19.64	-38.58	-17.62
61.95	-19.55	-18.67	-20.53	-38.98	-18.96
62.10	-19.47	-18.59	-20.45	-38.91	-18.51
62.25	-17.95	-17.15	-18.83	-38.27	-17.25
62.40	-18.66	-17.85	-19.55	-38.88	-19.90
62.55	-22.47	-21.33	-23.78	-39.52	-19.98
62.70	-25.85	-24.25	-27.81	-39.74	-18.56
62.85	-20.64	-19.68	-21.72	-39.29	-20.14
63.00	-18.28	-17.52	-19.12	-39.02	-21.92
63.15	-17.78	-17.03	-18.61	-38.64	-19.84
63.30	-22.19	-21.09	-23.45	-39.61	-22.34
63.45	-24.30	-22.96	-25.89	-39.86	-27.28
63.60	-19.34	-18.52	-20.25	-39.40	-24.17
63.75	-18.58	-17.80	-19.43	-39.15	-22.59
63.90	-20.92	-19.96	-22.00	-39.56	-23.86
64.05	-23.31	-22.11	-24.71	-39.87	-30.10
64.20	-21.32	-20.35	-22.42	-39.85	-32.74
64.35	-19.01	-18.23	-19.86	-39.60	-28.42
64.50	-18.13	-17.40	-18.92	-39.33	-25.61
64.65	-18.69	-17.93	-19.52	-39.52	-27.46
64.80	-20.92	-19.99	-21.96	-39.86	-34.14
64.95	-23.53	-22.30	-24.96	-39.90	-31.83
65.10	-23.53	-22.29	-24.98	-39.83	-26.84
65.25	-21.04	-20.08	-22.11	-39.75	-28.49
65.40	-19.16	-18.38	-20.01	-39.72	-31.30
65.55	-18.53	-17.80	-19.31	-39.76	-34.14
65.70	-19.73	-18.89	-20.66	-39.62	-27.60
65.85	-20.62	-19.70	-21.66	-39.61	-25.56
66.00	-21.39	-20.38	-22.53	-39.59	-23.57
66.15	-23.63	-22.37	-25.10	-39.79	-25.10
66.30	-25.98	-24.39	-27.92	-39.92	-29.02
66.45	-21.71	-20.68	-22.88	-39.73	-26.55
66.60	-18.79	-18.01	-19.64	-39.35	-24.57
66.75	-18.24	-17.50	-19.05	-39.22	-24.04
66.90	-20.16	-19.29	-21.13	-39.66	-27.67
67.05	-24.77	-23.35	-26.47	-39.79	-22.74
67.20	-21.33	-20.31	-22.48	-39.45	-21.02
67.35	-20.72	-19.76	-21.79	-39.41	-21.59
67.50	-22.57	-21.40	-23.93	-39.35	-17.09
67.65	-21.94	-20.95	-23.19	-39.39	-18.82
67.80	-20.56	-19.60	-21.64	-39.22	-19.48
67.95	-19.58	-18.72	-20.54	-39.17	-20.84
68.10	-19.42	-18.56	-20.37	-39.06	-19.98
68.25	-19.96	-19.04	-20.99	-38.97	-18.05
68.40	-21.31	-20.29	-22.47	-39.39	-20.17
68.55	-22.39	-21.25	-23.70	-39.48	-19.43
68.70	-22.60	-21.46	-23.91	-39.66	-22.67
68.85	-23.06	-21.97	-24.44	-39.70	-22.89
69.00	-24.02	-22.70	-25.57	-39.72	-21.56

REPRODUCED AT GOVERNMENT EXPENSE

TABLE V (cont.)

69.15	-21.99	-20.90	-23.23	-39.47	-20.04
69.30	-20.17	-19.25	-21.19	-39.27	-20.75
69.45	-20.20	-19.28	-21.23	-39.24	-20.34
69.60	-21.68	-20.61	-22.90	-39.34	-18.72
69.75	-21.83	-20.74	-23.09	-39.25	-17.20
69.90	-21.27	-20.23	-22.46	-39.12	-16.94
70.05	-22.70	-21.53	-24.05	-39.54	-19.96
70.20	-20.62	-19.65	-21.70	-39.23	-19.40
70.35	-18.30	-17.50	-19.18	-38.61	-18.61
70.50	-18.41	-17.61	-19.29	-38.73	-19.22
70.65	-20.21	-19.29	-21.24	-39.23	-20.20
70.80	-21.23	-20.22	-22.38	-39.41	-20.54
70.95	-20.15	-19.24	-21.17	-39.26	-20.75
71.10	-19.70	-18.83	-20.67	-39.26	-21.55
71.25	-21.19	-20.20	-22.30	-39.56	-23.33
71.40	-21.02	-20.84	-22.13	-39.45	-21.59
71.55	-20.11	-19.21	-21.10	-39.41	-22.86
71.70	-22.07	-20.99	-23.29	-39.68	-24.26
71.85	-20.66	-19.73	-21.69	-39.65	-26.43
72.00	-18.09	-17.36	-18.89	-39.20	-24.08
72.15	-19.57	-18.71	-20.53	-39.19	-21.11
72.30	-24.26	-22.92	-25.86	-39.78	-23.16
72.45	-22.73	-21.59	-24.04	-39.78	-26.21
72.60	-20.84	-19.90	-21.89	-39.69	-27.08
72.75	-20.55	-19.64	-21.58	-39.64	-26.42
72.90	-20.52	-19.61	-21.54	-39.64	-26.42
73.05	-20.42	-19.54	-21.41	-39.84	-33.74
73.20	-20.71	-19.80	-21.72	-39.88	-36.01
73.35	-20.32	-19.43	-21.30	-39.73	-29.41
73.50	-20.38	-19.49	-21.37	-39.69	-28.06
73.65	-21.33	-20.35	-22.43	-39.79	-29.41
73.80	-22.00	-20.95	-23.19	-39.84	-30.82
73.95	-21.89	-20.85	-23.07	-39.84	-30.73
74.10	-20.81	-19.89	-21.84	-39.80	-31.21
74.25	-20.28	-19.38	-21.27	-39.57	-25.40
74.40	-20.47	-19.55	-21.51	-39.45	-22.78
74.55	-21.09	-20.10	-22.20	-39.48	-21.96
74.70	-21.50	-20.47	-22.67	-39.52	-21.89
74.85	-20.96	-20.00	-22.03	-39.65	-25.71
75.00	-21.66	-20.61	-22.86	-39.48	-20.90
75.15	-22.34	-21.20	-23.65	-39.42	-18.49
75.30	-19.54	-18.68	-20.48	-39.27	-22.09
75.45	-19.45	-18.62	-20.36	-39.50	-25.61
75.60	-24.07	-22.74	-25.65	-39.68	-20.29
75.75	-22.34	-21.22	-23.62	-39.60	-21.82
75.90	-20.16	-19.26	-21.17	-39.34	-21.72
76.05	-19.66	-18.78	-20.65	-39.09	-19.85
76.20	-20.96	-19.96	-22.09	-39.25	-19.03
76.35	-22.36	-21.22	-23.68	-39.39	-18.05
76.50	-21.47	-20.42	-22.66	-39.33	-18.96
76.65	-21.56	-20.50	-22.76	-39.32	-18.63
76.80	-22.58	-21.40	-23.95	-39.33	-16.81
76.95	-22.03	-20.91	-23.31	-39.29	-17.29
77.10	-21.56	-20.53	-22.73	-39.53	-21.89
77.25	-21.20	-20.19	-22.35	-39.34	-19.64
77.40	-21.11	-20.10	-22.26	-39.30	-19.25
77.55	-21.05	-20.06	-22.16	-39.43	-21.30
77.70	-21.48	-20.41	-22.70	-39.11	-16.41
77.85	-22.14	-20.99	-23.46	-39.14	-15.42
78.00	-22.79	-21.58	-24.20	-39.29	-15.84
78.15	-23.46	-22.18	-24.95	-39.50	-17.55
78.30	-23.78	-22.49	-25.29	-39.70	-21.49
78.45	-23.16	-21.94	-24.58	-39.62	-20.60
78.60	-22.01	-20.93	-23.24	-39.59	-22.23
78.75	-20.75	-19.75	-21.87	-39.87	-17.48
78.90	-21.25	-20.22	-22.41	-39.27	-18.65

REPRODUCED AT GOVERNMENT EXPENSE

TABLE V (cont.)

79.05	-23.66	-22.39	-25.15	-39.70	-21.62
79.20	-22.98	-21.76	-24.41	-39.37	-16.49
79.35	-21.33	-20.30	-22.51	-39.28	-18.56
79.50	-21.11	-20.12	-22.23	-39.50	-22.30
79.65	-20.86	-19.90	-21.94	-39.51	-23.01
79.80	-20.93	-19.94	-22.06	-39.25	-19.03
79.95	-21.71	-20.64	-22.94	-39.34	-18.65
80.10	-25.41	-23.80	-27.28	-39.68	-17.57
80.25	-21.07	-20.07	-22.20	-39.35	-19.98
80.40	-19.51	-18.60	-20.53	-38.63	-16.35
80.55	-26.43	-24.73	-28.56	-39.70	-16.14
80.70	-19.55	-18.67	-20.53	-38.98	-18.96
80.85	-18.66	-17.85	-19.55	-38.88	-19.90
81.00	-20.64	-19.68	-21.72	-39.29	-20.14
81.15	-22.19	-21.09	-23.45	-39.61	-22.34
81.30	-18.58	-17.80	-19.43	-39.15	-22.59
81.45	-21.32	-20.35	-22.42	-39.85	-32.74
81.60	-18.69	-17.93	-19.52	-39.52	-27.46
81.75	-23.53	-22.29	-24.98	-39.83	-26.84
81.90	-18.53	-17.80	-19.31	-39.76	-34.14
82.05	-21.39	-20.38	-22.53	-39.59	-23.57
82.20	-21.71	-20.68	-22.88	-39.73	-26.55
82.35	-20.16	-19.29	-21.13	-39.66	-27.67
82.50	-20.72	-19.76	-21.79	-39.41	-21.59
82.65	-20.56	-19.60	-21.64	-39.22	-19.48
82.80	-19.96	-19.04	-20.99	-38.97	-18.05
82.95	-22.60	-21.46	-23.91	-39.66	-22.67
83.10	-21.99	-20.90	-23.23	-39.47	-20.04
83.25	-21.68	-20.61	-22.90	-39.34	-18.72
83.40	-22.70	-21.53	-24.05	-39.54	-19.96
83.55	-18.41	-17.61	-19.29	-38.73	-19.22
83.70	-20.15	-19.24	-21.17	-39.26	-20.75
83.85	-21.02	-20.04	-22.13	-39.45	-21.59
84.00	-20.66	-19.73	-21.69	-39.65	-26.43
84.15	-24.26	-22.92	-25.86	-39.78	-23.16
84.30	-20.55	-19.64	-21.58	-39.64	-26.42
84.45	-20.71	-19.80	-21.72	-39.88	-36.01
84.60	-21.33	-20.35	-22.43	-39.79	-29.41
84.75	-20.81	-19.89	-21.84	-39.80	-31.21
84.90	-21.09	-20.10	-22.20	-39.48	-21.96
85.05	-21.66	-20.61	-22.86	-39.48	-20.90
85.20	-19.45	-18.62	-20.36	-39.50	-25.61
85.35	-20.16	-19.26	-21.17	-39.34	-21.72
85.50	-22.36	-21.22	-23.68	-39.39	-18.05
85.65	-22.58	-21.40	-23.95	-39.33	-16.81
85.80	-21.20	-20.19	-22.35	-39.34	-19.64
85.95	-21.48	-20.41	-22.70	-39.11	-16.41
86.10	-23.46	-22.18	-24.95	-39.50	-17.55
86.25	-22.01	-20.93	-23.24	-39.59	-22.23
86.40	-23.66	-22.39	-25.15	-39.70	-21.62
86.55	-21.11	-20.12	-22.23	-39.50	-22.30
86.70	-21.71	-20.64	-22.94	-39.34	-18.65
86.85	-19.51	-18.60	-20.53	-38.63	-16.35
87.00	-18.66	-17.85	-19.55	-38.88	-19.90
87.15	-18.58	-17.80	-19.43	-39.15	-22.59
87.30	-23.53	-22.29	-24.98	-39.83	-26.84
87.45	-21.71	-20.68	-22.88	-39.73	-26.55
87.60	-20.56	-19.60	-21.64	-39.22	-19.48
87.75	-21.99	-20.90	-23.23	-39.47	-20.04
87.90	-18.41	-17.61	-19.29	-38.73	-19.22
88.05	-20.66	-19.73	-21.69	-39.65	-26.43
88.20	-20.71	-19.80	-21.72	-39.88	-36.01
88.35	-21.09	-20.10	-22.20	-39.48	-21.96
88.50	-20.16	-19.26	-21.17	-39.34	-21.72
88.65	-21.20	-20.19	-22.35	-39.34	-19.64
88.80	-22.01	-20.93	-23.24	-39.59	-22.23

REPRODUCED AT GOVERNMENT EXPENSE

TABLE V (cont.)

88.95	-21.71	-20.64	-22.94	-39.34	-18.65
89.10	-18.58	-17.80	-19.43	-39.15	-22.59
89.25	-20.56	-19.60	-21.64	-39.22	-19.48
89.40	-20.66	-19.73	-21.69	-39.65	-26.43
89.55	-20.16	-19.26	-21.17	-39.34	-21.72
89.70	-21.71	-20.64	-22.94	-39.34	-18.65
89.85	-20.66	-19.73	-21.69	-39.65	-26.43
90.00	-20.66	-19.73	-21.69	-39.65	-26.43

REPRODUCED AT GOVERNMENT EXPENSE

TABLE VI
 PRINTED OUTPUT OF RETURN LOSS FOR 15 dB ATTENUATOR WITH
 SHORTED OUTPUT USING SCHOTTKY DIODE DETECTOR
 DEVICE UNDER TEST : 15 dB ATTENUATOR WITH SHORT

Frequency (GHz)	Return (dB)	Max Ret (dB)	Min Ret (dB)	Uncer (dB)	S22 (dB)
60.00	-19.89	-18.98	-20.98	-39.82	-18.70
60.15	-27.41	-25.54	-29.80	-39.79	-17.57
60.30	-26.13	-24.47	-28.17	-39.68	-16.18
60.45	-27.21	-25.38	-29.53	-39.80	-18.03
60.60	-30.54	-28.00	-34.14	-39.92	-19.98
60.75	-29.43	-27.14	-32.54	-39.86	-16.86
60.90	-27.86	-25.89	-30.40	-39.77	-15.63
61.05	-25.85	-24.24	-27.83	-39.66	-16.35
61.20	-24.95	-23.48	-26.72	-39.62	-17.20
61.35	-26.72	-24.97	-28.92	-39.74	-16.90
61.50	-30.36	-27.86	-33.90	-39.88	-16.14
61.65	-26.00	-24.37	-28.02	-39.68	-16.59
61.80	-24.82	-23.37	-26.56	-39.63	-17.62
61.95	-27.15	-25.33	-29.45	-39.81	-13.96
62.10	-25.97	-24.35	-27.95	-39.74	-18.51
62.25	-23.54	-22.25	-25.04	-39.49	-17.25
62.40	-23.72	-22.43	-25.23	-39.63	-19.90
62.55	-27.59	-25.69	-30.81	-39.85	-19.98
62.70	-31.59	-28.78	-35.79	-39.93	-18.56
62.85	-25.92	-24.32	-27.89	-39.78	-20.14
63.00	-23.23	-22.01	-24.64	-39.68	-21.92
63.15	-22.46	-21.32	-23.78	-39.51	-19.84
63.30	-26.53	-24.83	-28.63	-39.85	-22.34
63.45	-31.94	-29.04	-36.33	-39.98	-27.28
63.60	-25.67	-24.12	-27.56	-39.86	-24.17
63.75	-25.35	-23.84	-27.17	-39.81	-22.59
63.90	-28.61	-26.52	-31.37	-39.92	-23.86
64.05	-37.66	-32.73	-50.21	-40.00	-30.10
64.20	-28.11	-26.13	-30.67	-39.97	-32.74
64.35	-24.69	-23.38	-26.35	-39.89	-28.42
64.50	-23.53	-22.29	-24.98	-39.80	-25.61
64.65	-24.38	-22.97	-25.89	-39.86	-27.46
64.80	-27.85	-25.93	-30.32	-39.97	-34.14
64.95	-35.81	-31.13	-42.21	-39.99	-31.83
65.10	-34.45	-30.77	-40.99	-39.99	-26.84
65.25	-27.92	-25.98	-30.42	-39.95	-28.49
65.40	-24.81	-23.41	-26.49	-39.92	-31.30
65.55	-24.21	-22.90	-25.76	-39.94	-34.14
65.70	-26.13	-24.52	-28.12	-39.91	-27.60
65.85	-28.03	-26.06	-30.57	-39.93	-25.56
66.00	-29.07	-26.88	-32.00	-39.93	-23.57
66.15	-32.52	-29.45	-37.31	-39.97	-25.10
66.30	-35.76	-31.60	-44.03	-39.99	-29.02
66.45	-27.11	-25.32	-29.37	-39.92	-26.55
66.60	-23.96	-22.66	-25.49	-39.88	-24.57
66.75	-23.26	-22.05	-24.67	-39.75	-24.04
66.90	-25.66	-24.12	-27.54	-39.90	-27.67
67.05	-35.57	-31.48	-43.57	-39.98	-22.74
67.20	-29.93	-27.54	-33.24	-39.92	-21.02
67.35	-29.64	-27.32	-32.82	-39.92	-21.59
67.50	-34.84	-30.48	-40.17	-39.95	-17.09
67.65	-38.48	-27.95	-34.06	-39.91	-18.82
67.80	-27.52	-25.64	-29.93	-39.84	-19.48
67.95	-25.77	-24.19	-27.69	-39.79	-20.84
68.10	-25.44	-23.92	-27.38	-39.76	-19.98
68.25	-26.24	-24.58	-28.31	-39.75	-18.05
68.40	-28.04	-26.06	-30.61	-39.87	-20.17
68.55	-31.28	-28.55	-35.28	-39.93	-19.43
68.70	-34.20	-30.60	-40.47	-39.98	-22.67
68.85	-34.66	-30.90	-41.45	-39.98	-22.89
69.00	-37.26	-32.50	-48.66	-39.99	-21.56

REPRODUCED AT GOVERNMENT EXPENSE

TABLE VI (cont.)

69.15	-29.14	-26.93	-32.11	-39.90	-20.04
69.38	-26.31	-24.64	-28.37	-39.82	-20.75
69.45	-26.55	-24.84	-28.67	-39.82	-20.34
69.60	-28.72	-26.60	-31.54	-39.87	-18.72
69.75	-28.91	-26.74	-31.81	-39.85	-17.20
69.90	-28.39	-26.32	-31.10	-39.82	-16.94
70.05	-32.53	-29.45	-37.35	-39.95	-19.96
70.20	-27.46	-25.58	-29.85	-39.83	-19.40
70.35	-24.35	-22.97	-26.00	-39.63	-18.61
70.50	-24.56	-23.15	-26.23	-39.67	-19.22
70.65	-27.52	-25.64	-29.92	-39.85	-20.20
70.80	-32.04	-29.10	-36.51	-39.95	-20.54
70.95	-28.72	-26.60	-31.53	-39.89	-20.75
71.10	-27.77	-25.85	-30.25	-39.88	-21.55
71.25	-30.81	-28.21	-34.54	-39.95	-23.33
71.40	-31.53	-28.74	-35.67	-39.95	-21.59
71.55	-28.77	-26.65	-31.59	-39.92	-22.86
71.70	-34.00	-30.47	-40.07	-39.98	-24.26
71.85	-27.55	-25.68	-29.94	-39.93	-26.43
72.00	-23.81	-22.53	-25.31	-39.78	-24.08
72.15	-24.99	-23.54	-26.75	-39.76	-21.11
72.30	-34.99	-31.11	-42.18	-39.98	-23.16
72.45	-33.37	-30.04	-38.84	-39.98	-26.21
72.60	-29.93	-27.55	-33.22	-39.96	-27.08
72.75	-29.63	-27.32	-32.79	-39.96	-26.42
72.90	-29.65	-27.34	-32.82	-39.96	-26.42
73.05	-28.89	-26.76	-31.74	-39.98	-33.74
73.20	-29.78	-27.44	-32.98	-39.99	-36.01
73.35	-28.75	-26.64	-31.54	-39.96	-29.41
73.50	-28.50	-26.44	-31.21	-39.95	-28.06
73.65	-30.84	-28.24	-34.58	-39.98	-29.41
73.80	-33.20	-29.93	-38.52	-39.99	-30.82
73.95	-32.26	-29.27	-36.85	-39.99	-30.73
74.10	-30.25	-27.80	-33.68	-39.98	-31.21
74.25	-28.50	-26.43	-31.20	-39.93	-25.40
74.40	-28.56	-26.48	-31.29	-39.91	-22.78
74.55	-30.05	-27.64	-33.41	-39.93	-21.96
74.70	-31.23	-28.52	-35.20	-39.95	-21.89
74.85	-29.94	-27.56	-33.24	-39.95	-25.71
75.00	-31.72	-28.87	-35.98	-39.95	-28.90
75.15	-34.78	-30.97	-41.72	-39.97	-18.49
75.30	-26.62	-24.90	-28.75	-39.85	-22.09
75.45	-25.84	-24.26	-27.76	-39.88	-25.61
75.60	-35.12	-31.19	-42.50	-39.97	-20.29
75.75	-31.45	-28.68	-35.55	-39.95	-21.82
75.90	-27.38	-25.53	-29.73	-39.87	-21.72
76.05	-26.54	-24.84	-28.67	-39.81	-19.85
76.20	-28.62	-26.52	-31.40	-39.87	-19.03
76.35	-34.22	-30.60	-40.52	-39.96	-18.05
76.50	-30.92	-28.28	-34.72	-39.92	-18.96
76.65	-30.67	-28.10	-34.34	-39.91	-18.63
76.80	-33.77	-30.30	-39.63	-39.95	-16.81
76.95	-31.94	-29.02	-36.35	-39.92	-17.29
77.10	-30.19	-27.74	-33.62	-39.93	-21.89
77.25	-29.28	-27.04	-32.31	-39.89	-19.64
77.40	-29.06	-26.86	-32.00	-39.88	-19.25
77.55	-28.75	-26.63	-31.57	-39.90	-21.30
77.70	-29.79	-27.42	-33.06	-39.86	-16.41
77.85	-30.85	-28.22	-34.64	-39.88	-15.42
78.00	-33.18	-29.90	-38.53	-39.93	-15.84
78.15	-34.87	-31.03	-41.93	-39.96	-17.55
78.30	-35.99	-31.74	-44.67	-39.98	-21.49
78.45	-34.86	-31.03	-41.89	-39.97	-20.60
78.60	-30.29	-27.82	-33.76	-39.94	-22.23
78.75	-28.30	-26.26	-30.98	-39.83	-17.48
78.90	-29.17	-26.95	-32.16	-39.88	-18.65

TABLE VI (cont.)

79.05	-37.71	-32.75	-50.44	-39.99	-21.62
79.20	-33.29	-29.97	-38.73	-39.94	-16.49
79.35	-29.22	-26.98	-32.23	-39.88	-18.56
79.50	-28.63	-26.53	-31.39	-39.91	-22.30
79.65	-28.19	-26.19	-30.80	-39.91	-23.01
79.80	-28.29	-26.25	-30.95	-39.86	-19.03
79.95	-29.56	-27.25	-32.72	-39.89	-18.65
80.10	-27.41	-25.54	-29.88	-39.79	-17.57
80.25	-30.54	-28.88	-34.14	-39.92	-19.98
80.40	-25.85	-24.24	-27.83	-39.66	-16.35
80.55	-30.36	-27.86	-33.90	-39.88	-16.14
80.70	-27.15	-25.33	-29.45	-39.81	-18.96
80.85	-23.72	-22.43	-25.23	-39.63	-19.90
81.00	-25.92	-24.32	-27.89	-39.78	-20.14
81.15	-26.53	-24.83	-28.63	-39.85	-22.34
81.30	-25.35	-23.84	-27.17	-39.81	-22.59
81.45	-28.11	-26.13	-30.67	-39.97	-32.74
81.60	-24.30	-22.97	-25.89	-39.86	-27.46
81.75	-34.45	-30.77	-40.99	-39.99	-26.84
81.90	-24.21	-22.90	-25.76	-39.94	-34.14
82.05	-29.07	-26.88	-32.80	-39.93	-23.57
82.20	-27.11	-25.32	-29.37	-39.92	-26.55
82.35	-25.66	-24.12	-27.54	-39.90	-27.67
82.50	-29.64	-27.32	-32.82	-39.92	-21.59
82.65	-27.52	-25.64	-29.93	-39.84	-19.48
82.80	-26.24	-24.58	-28.31	-39.75	-18.05
82.95	-34.20	-30.60	-40.47	-39.98	-22.67
83.10	-29.14	-26.93	-32.11	-39.90	-20.04
83.25	-28.72	-26.60	-31.54	-39.87	-18.72
83.40	-32.53	-29.45	-37.35	-39.95	-19.96
83.55	-24.56	-23.15	-26.23	-39.67	-19.22
83.70	-28.72	-26.60	-31.53	-39.89	-20.75
83.85	-31.53	-28.74	-35.67	-39.95	-21.59
84.00	-27.55	-25.68	-29.94	-39.93	-26.43
84.15	-34.99	-31.11	-42.18	-39.98	-23.16
84.30	-29.63	-27.32	-32.79	-39.96	-26.42
84.45	-29.78	-27.44	-32.98	-39.99	-36.01
84.60	-30.84	-28.24	-34.58	-39.98	-29.41
84.75	-30.25	-27.80	-33.68	-39.98	-31.21
84.90	-30.05	-27.64	-33.41	-39.93	-21.96
85.05	-31.72	-28.87	-35.98	-39.95	-20.90
85.20	-25.84	-24.26	-27.76	-39.88	-25.61
85.35	-27.38	-25.53	-29.73	-39.87	-21.72
85.50	-34.22	-30.60	-40.52	-39.96	-18.05
85.65	-33.77	-30.30	-39.63	-39.95	-16.81
85.80	-29.28	-27.84	-32.31	-39.89	-19.64
85.95	-29.79	-27.42	-33.86	-39.86	-16.41
86.10	-34.87	-31.03	-41.93	-39.96	-17.55
86.25	-30.29	-27.82	-33.76	-39.94	-22.23
86.40	-37.71	-32.75	-50.44	-39.99	-21.62
86.55	-28.63	-26.53	-31.39	-39.91	-22.30
86.70	-29.56	-27.25	-32.72	-39.89	-18.65
86.85	-25.85	-24.24	-27.83	-39.66	-16.35
87.00	-23.72	-22.43	-25.23	-39.63	-19.90
87.15	-25.35	-23.84	-27.17	-39.81	-22.59
87.30	-34.45	-30.77	-40.99	-39.99	-26.84
87.45	-27.11	-25.32	-29.37	-39.92	-26.55
87.60	-27.52	-25.64	-29.93	-39.84	-19.48
87.75	-29.14	-26.93	-32.11	-39.90	-20.04
87.90	-24.56	-23.15	-26.23	-39.67	-19.22
88.05	-27.55	-25.68	-29.94	-39.93	-26.43
88.20	-29.78	-27.44	-32.98	-39.99	-36.01
88.35	-30.05	-27.64	-33.41	-39.93	-21.96
88.50	-27.38	-25.53	-29.73	-39.87	-21.72
88.65	-29.28	-27.84	-32.31	-39.89	-19.64
88.80	-30.29	-27.82	-33.76	-39.94	-22.23

TABLE VI (cont.)

88.95	-29.56	-27.25	-32.72	-39.89	-18.65
89.10	-25.35	-23.84	-27.17	-39.81	-22.59
89.25	-27.52	-25.64	-29.93	-39.84	-19.48
89.40	-27.55	-25.68	-29.94	-39.93	-26.43
89.55	-27.38	-25.53	-29.73	-39.87	-21.72
89.70	-29.56	-27.25	-32.72	-39.89	-18.65
89.85	-27.55	-25.68	-29.94	-39.93	-26.43
90.00	-27.55	-25.68	-29.94	-39.93	-26.43

REPRODUCED AT GOVERNMENT EXPENSE

TABLE VII
 PRINTED OUTPUT OF RETURN LOSS FOR 18 dB ATTENUATOR WITH
 SHORTED OUTPUT USING SCHOTTKY DIODE DETECTOR

DEVICE UNDER TEST : 18 dB ATTENUATOR WITH SHORT

Frequency (GHz)	Return (dB)	Max Ret (dB)	Min Ret (dB)	Uncer (dB)	S22 (dB)
60.00	-20.28	-19.34	-21.34	-39.10	-18.70
60.15	-25.04	-23.56	-26.83	-39.65	-17.57
60.30	-27.32	-25.46	-29.70	-39.75	-16.18
60.45	-30.32	-27.83	-33.83	-39.90	-18.03
60.60	-32.01	-29.08	-36.47	-39.95	-19.98
60.75	-34.00	-30.51	-40.25	-39.95	-16.86
60.90	-30.07	-27.63	-33.46	-39.86	-15.63
61.05	-28.61	-26.50	-31.41	-39.82	-16.35
61.20	-27.34	-25.48	-29.72	-39.78	-17.20
61.35	-27.04	-25.23	-29.32	-39.76	-16.90
61.50	-27.61	-25.69	-30.07	-39.77	-16.14
61.65	-26.32	-24.64	-28.42	-39.70	-16.59
61.80	-26.50	-24.79	-28.64	-39.75	-17.62
61.95	-31.31	-28.57	-35.33	-39.93	-18.96
62.10	-28.94	-26.77	-31.84	-39.87	-18.51
62.25	-25.81	-24.21	-27.77	-39.69	-17.25
62.40	-25.46	-23.93	-27.32	-39.75	-19.90
62.55	-26.93	-25.16	-29.17	-39.83	-19.98
62.70	-28.24	-26.21	-30.89	-39.85	-18.56
62.85	-26.05	-24.42	-28.05	-39.79	-20.14
63.00	-24.86	-23.42	-26.58	-39.78	-21.92
63.15	-24.16	-22.81	-25.75	-39.67	-19.84
63.30	-26.41	-24.73	-28.49	-39.85	-22.34
63.45	-29.30	-27.06	-32.31	-39.96	-27.28
63.60	-27.64	-25.75	-30.07	-39.91	-24.17
63.75	-28.32	-26.29	-30.97	-39.91	-22.59
63.90	-32.61	-29.51	-37.48	-39.97	-23.86
64.05	-38.83	-33.37	-56.84	-40.00	-30.10
64.20	-29.88	-27.52	-33.13	-39.98	-32.74
64.35	-26.81	-25.08	-28.98	-39.93	-28.42
64.50	-25.72	-24.16	-27.61	-39.88	-25.61
64.65	-26.33	-24.68	-28.37	-39.91	-27.46
64.80	-29.22	-27.01	-32.18	-39.98	-34.14
64.95	-32.94	-29.75	-38.05	-39.99	-31.83
65.10	-33.88	-30.38	-39.81	-39.98	-26.84
65.25	-29.09	-26.90	-32.02	-39.96	-28.49
65.40	-26.63	-24.93	-28.74	-39.95	-31.30
65.55	-26.56	-24.88	-28.65	-39.96	-34.14
65.70	-28.60	-26.52	-31.34	-39.95	-27.60
65.85	-30.76	-28.17	-34.45	-39.96	-25.56
66.00	-31.07	-28.40	-34.94	-39.96	-23.57
66.15	-31.53	-28.74	-35.66	-39.97	-25.10
66.30	-30.72	-28.15	-34.39	-39.97	-29.02
66.45	-27.68	-25.78	-30.11	-39.93	-26.55
66.60	-25.67	-24.12	-27.55	-39.86	-24.57
66.75	-25.23	-23.75	-27.02	-39.84	-24.04
66.90	-27.21	-25.40	-29.49	-39.93	-27.67
67.05	-32.00	-29.65	-37.82	-39.97	-22.74
67.20	-33.18	-29.90	-38.49	-39.96	-21.02
67.35	-33.54	-30.15	-39.17	-39.97	-21.59
67.50	-40.59	-34.26	-120.00	-39.99	-17.09
67.65	-33.79	-30.32	-39.66	-39.96	-18.82
67.80	-38.07	-27.64	-33.44	-39.91	-19.48
67.95	-27.89	-25.94	-30.41	-39.87	-20.84
68.10	-27.89	-25.94	-30.42	-39.86	-19.98
68.25	-28.62	-26.51	-31.40	-39.85	-18.05
68.40	-30.29	-27.81	-33.77	-39.92	-20.17
68.55	-34.03	-30.48	-40.14	-39.96	-19.43
68.70	-36.19	-31.86	-45.21	-39.98	-22.67
68.85	-36.86	-32.26	-47.24	-39.99	-22.89
69.00	-34.48	-30.78	-41.07	-39.97	-21.56

TABLE VII (cont.)

69.15	-30.38	-27.88	-33.91	-39.92	-20.04
69.30	-28.32	-26.29	-30.99	-39.88	-20.75
69.45	-28.54	-26.46	-31.29	-39.88	-20.34
69.60	-31.44	-28.66	-35.54	-39.93	-18.72
69.75	-30.82	-28.20	-34.58	-39.90	-17.20
69.90	-30.37	-27.86	-33.90	-39.89	-16.94
70.05	-29.72	-27.38	-32.94	-39.91	-19.96
70.20	-27.74	-25.82	-30.22	-39.84	-19.40
70.35	-26.23	-24.57	-28.29	-39.76	-18.61
70.50	-26.00	-25.05	-29.00	-39.80	-19.22
70.65	-30.37	-27.87	-33.88	-39.92	-20.20
70.80	-38.28	-33.07	-53.26	-39.99	-20.54
70.95	-33.77	-30.31	-39.62	-39.97	-20.75
71.10	-30.33	-27.85	-33.82	-39.93	-21.55
71.25	-34.61	-30.87	-41.34	-39.98	-23.33
71.40	-37.75	-32.77	-50.61	-39.99	-21.59
71.55	-33.30	-29.99	-38.71	-39.97	-22.86
71.70	-38.22	-33.04	-52.91	-39.99	-24.26
71.85	-29.83	-27.47	-33.07	-39.96	-26.43
72.00	-25.71	-24.15	-27.61	-39.86	-24.08
72.15	-26.62	-24.90	-28.76	-39.84	-21.11
72.30	-32.90	-29.72	-37.99	-39.97	-23.16
72.45	-36.25	-31.90	-45.36	-39.99	-26.21
72.60	-32.83	-29.67	-37.84	-39.98	-27.08
72.75	-35.30	-31.31	-42.89	-39.99	-26.42
72.90	-33.97	-30.44	-39.99	-39.98	-26.42
73.05	-33.75	-30.30	-39.55	-39.99	-33.74
73.20	-35.58	-31.49	-43.57	-40.00	-36.01
73.35	-32.45	-29.40	-37.18	-39.98	-29.41
73.50	-32.08	-29.14	-36.56	-39.98	-28.06
73.65	-34.67	-30.91	-41.44	-39.99	-29.41
73.80	-39.90	-33.93	-78.82	-40.00	-30.82
73.95	-40.79	-34.36	-120.00	-40.00	-30.73
74.10	-33.91	-30.41	-39.86	-39.99	-31.21
74.25	-32.26	-29.27	-36.87	-39.97	-25.40
74.40	-33.41	-30.06	-38.91	-39.97	-22.78
74.55	-35.53	-31.46	-43.48	-39.98	-21.96
74.70	-40.14	-34.05	-120.00	-39.99	-21.89
74.85	-37.10	-32.41	-48.07	-39.99	-25.71
75.00	-35.64	-31.52	-43.74	-39.98	-20.90
75.15	-39.78	-33.87	-72.42	-39.99	-18.49
75.30	-29.27	-27.04	-32.29	-39.92	-22.09
75.45	-28.06	-26.08	-30.61	-39.93	-25.61
75.60	-33.55	-30.16	-39.20	-39.96	-20.29
75.75	-33.39	-30.05	-38.89	-39.97	-21.82
75.90	-30.22	-27.76	-33.66	-39.93	-21.72
76.05	-29.41	-27.14	-32.49	-39.90	-19.85
76.20	-31.83	-28.95	-36.16	-39.94	-19.03
76.35	-40.68	-34.31	-120.00	-39.99	-18.05
76.50	-36.25	-31.89	-45.39	-39.98	-18.96
76.65	-36.03	-31.76	-44.77	-39.97	-18.63
76.80	-41.49	-34.69	-120.00	-39.99	-16.81
76.95	-37.61	-32.69	-50.05	-39.98	-17.29
77.10	-34.66	-30.90	-41.45	-39.98	-21.89
77.25	-32.78	-29.63	-37.78	-39.95	-19.64
77.40	-32.95	-29.74	-38.08	-39.95	-19.25
77.55	-32.63	-29.52	-37.51	-39.96	-21.30
77.70	-33.58	-30.17	-39.26	-39.94	-16.41
77.85	-34.69	-30.91	-41.54	-39.95	-15.42
78.00	-37.39	-32.57	-49.18	-39.97	-15.94
78.15	-37.84	-32.83	-51.07	-39.98	-17.55
78.30	-42.43	-35.11	-120.00	-40.00	-21.49
78.45	-39.15	-33.54	-59.87	-39.99	-20.60
78.60	-34.78	-30.97	-41.71	-39.98	-22.23
78.75	-31.62	-28.79	-35.83	-39.92	-17.48
78.90	-32.16	-29.19	-36.72	-39.94	-18.65

REPRODUCED AT GOVERNMENT EXPENSE

TABLE VII (cont.)

79.05	-38.32	-33.09	-53.47	-39.99	-21.62
79.20	-36.18	-31.85	-45.21	-39.97	-16.49
79.35	-32.92	-29.72	-38.84	-39.95	-18.56
79.50	-32.14	-29.18	-36.67	-39.96	-22.30
79.65	-30.71	-28.13	-34.38	-39.95	-23.01
79.80	-31.20	-28.49	-35.16	-39.93	-19.03
79.95	-31.65	-28.82	-35.88	-39.93	-18.65
80.10	-25.84	-23.56	-26.83	-39.65	-17.57
80.25	-32.01	-29.08	-36.47	-39.95	-19.98
80.40	-28.61	-26.50	-31.41	-39.82	-16.35
80.55	-27.61	-25.69	-30.07	-39.77	-16.14
80.70	-31.31	-28.57	-35.33	-39.93	-18.96
80.85	-25.46	-23.93	-27.32	-39.75	-19.90
81.00	-26.05	-24.42	-28.05	-39.79	-20.14
81.15	-26.41	-24.73	-28.49	-39.85	-22.34
81.30	-28.32	-26.29	-30.97	-39.91	-22.59
81.45	-29.88	-27.52	-33.13	-39.98	-32.74
81.60	-26.33	-24.68	-28.37	-39.91	-27.46
81.75	-33.88	-30.38	-39.81	-39.98	-26.84
81.90	-26.56	-24.88	-28.65	-39.96	-34.14
82.05	-31.07	-28.40	-34.94	-39.96	-23.57
82.20	-27.68	-25.78	-30.11	-39.93	-26.55
82.35	-27.21	-25.40	-29.49	-39.93	-27.67
82.50	-33.54	-30.15	-39.17	-39.97	-21.59
82.65	-30.07	-27.64	-33.44	-39.91	-19.48
82.80	-28.62	-26.51	-31.40	-39.85	-18.05
82.95	-36.19	-31.86	-45.21	-39.98	-22.67
83.10	-30.38	-27.88	-33.91	-39.92	-20.84
83.25	-31.44	-28.66	-35.54	-39.93	-18.72
83.40	-29.72	-27.38	-32.94	-39.91	-19.96
83.55	-26.80	-25.05	-29.00	-39.80	-19.22
83.70	-33.77	-30.31	-39.62	-39.97	-20.75
83.85	-37.75	-32.77	-50.61	-39.99	-21.59
84.00	-29.83	-27.47	-33.07	-39.96	-26.43
84.15	-32.90	-29.72	-37.99	-39.97	-23.16
84.30	-35.30	-31.31	-42.89	-39.99	-26.42
84.45	-35.58	-31.49	-43.57	-40.00	-36.01
84.60	-34.67	-30.91	-41.44	-39.99	-29.41
84.75	-33.91	-30.41	-39.86	-39.99	-31.21
84.90	-35.53	-31.46	-43.48	-39.98	-21.96
85.05	-35.64	-31.52	-43.74	-39.98	-20.90
85.20	-28.06	-26.08	-30.61	-39.93	-25.61
85.35	-30.22	-27.76	-33.66	-39.93	-21.72
85.50	-40.68	-34.31	-120.00	-39.99	-18.05
85.65	-41.49	-34.69	-120.00	-39.99	-16.81
85.80	-32.78	-29.63	-37.78	-39.95	-19.64
85.95	-33.58	-30.17	-39.26	-39.94	-16.41
86.10	-37.84	-32.83	-51.07	-39.98	-17.55
86.25	-34.78	-30.97	-41.71	-39.98	-22.23
86.40	-38.32	-33.09	-53.47	-39.99	-21.62
86.55	-32.14	-29.18	-36.67	-39.96	-22.30
86.70	-31.65	-28.82	-35.88	-39.93	-18.65
86.85	-28.61	-26.50	-31.41	-39.82	-16.35
87.00	-25.46	-23.93	-27.32	-39.75	-19.90
87.15	-28.32	-26.29	-30.97	-39.91	-22.59
87.30	-33.88	-30.38	-39.81	-39.98	-26.34
87.45	-27.68	-25.78	-30.11	-39.93	-26.55
87.60	-30.07	-27.64	-33.44	-39.91	-19.48
87.75	-30.38	-27.88	-33.91	-39.92	-20.84
87.90	-26.80	-25.05	-29.00	-39.80	-19.22
88.05	-29.83	-27.47	-33.07	-39.96	-26.43
88.20	-35.58	-31.49	-43.57	-40.00	-36.01
88.35	-35.53	-31.46	-43.48	-39.98	-21.96
88.50	-30.22	-27.76	-33.66	-39.93	-21.72
88.65	-32.78	-29.63	-37.78	-39.95	-19.64
88.80	-34.78	-30.97	-41.71	-39.98	-22.23

TABLE VII (cont.)

88.95	-31.65	-28.82	-35.88	-39.93	-18.65
89.10	-28.32	-26.29	-30.97	-39.91	-22.59
89.25	-30.07	-27.64	-33.44	-39.91	-19.48
89.40	-29.83	-27.47	-33.07	-39.96	-26.43
89.55	-30.22	-27.76	-33.66	-39.93	-21.72
89.70	-31.65	-28.82	-35.88	-39.93	-18.65
89.85	-29.83	-27.47	-33.07	-39.96	-26.43
90.00	-29.83	-27.47	-33.07	-39.96	-26.43

REPRODUCED AT GOVERNMENT EXPENSE

TABLE IX
PRINTED OUTPUT OF INSERTION LOSS FOR 0 dB ATTENUATOR USING
SCHOTTKY DIODE DETECTOR

DEVICE UNDER TEST : 0 dB ATTENUATOR

Frequency (GHz)	Insertion (dB)	Max Ins (dB)	Min Ins (dB)	Max Unc (dB)	Min Unc (dB)
60.00	-.60	-.23	-.96	.37	-.37
60.30	-.61	-.44	-.78	.17	-.17
60.60	-.35	-.20	-.49	.15	-.15
60.90	-.26	-.08	-.45	.18	-.18
61.20	-.46	-.28	-.64	.18	-.18
61.50	-.59	-.42	-.75	.16	-.16
61.80	-.51	-.36	-.65	.14	-.14
62.10	-.27	-.12	-.41	.15	-.14
62.40	-.48	-.36	-.61	.13	-.13
62.70	-.55	-.37	-.72	.18	-.18
63.00	-.43	-.24	-.61	.19	-.18
63.30	-.46	-.28	-.64	.18	-.18
63.60	-.41	-.11	-.70	.30	-.29
63.90	-.41	-.24	-.57	.17	-.17
64.20	-.39	-.26	-.52	.13	-.13
64.50	-.32	-.18	-.46	.14	-.14
64.80	-.38	-.25	-.58	.12	-.12
65.10	-.35	-.26	-.44	.09	-.09
65.40	-.60	-.50	-.71	.10	-.10
65.70	-.40	-.27	-.53	.13	-.13
66.00	-.35	-.22	-.48	.13	-.13
66.30	-.43	-.33	-.53	.10	-.10
66.60	-.38	-.28	-.49	.10	-.10
66.90	-.35	-.16	-.53	.19	-.19
67.20	-.45	-.36	-.53	.08	-.08
67.50	-.39	-.23	-.54	.16	-.16
67.80	-.53	-.38	-.67	.14	-.14
68.10	-.33	-.24	-.43	.09	-.09
68.40	-.34	-.24	-.44	.10	-.10
68.70	-.36	-.27	-.45	.09	-.09
69.00	-.42	-.32	-.53	.11	-.11
69.30	-.31	-.15	-.47	.16	-.16
69.60	-.35	-.17	-.53	.18	-.18
69.90	-.32	-.15	-.49	.17	-.17
70.20	-.23	-.03	-.42	.20	-.19
70.50	-.42	-.29	-.54	.13	-.13
70.80	-.16	-.02	-.29	.14	-.13
71.10	-.31	-.20	-.42	.11	-.11
71.40	-.34	-.22	-.46	.12	-.12
71.70	-.32	-.22	-.42	.10	-.10
72.00	-.26	-.05	-.47	.21	-.21
72.30	-.25	-.07	-.43	.18	-.18
72.60	-.37	-.26	-.48	.11	-.11
72.90	-.27	-.17	-.37	.10	-.10
73.20	-.46	-.36	-.56	.10	-.10
73.50	-.42	-.32	-.53	.10	-.10
73.80	-.43	-.35	-.51	.08	-.08
74.10	-.33	-.27	-.39	.06	-.06
74.40	-.44	-.37	-.52	.08	-.08
74.70	-.44	-.36	-.53	.09	-.09
75.00	-.40	-.24	-.56	.16	-.16
75.30	-.37	-.25	-.49	.12	-.12
75.60	-.46	-.35	-.56	.11	-.11
75.90	-.42	-.32	-.52	.10	-.10
76.20	-.32	-.22	-.42	.10	-.10
76.50	-.47	-.38	-.57	.09	-.09
76.80	-.53	-.45	-.61	.08	-.08
77.10	-.49	-.40	-.58	.09	-.09
77.40	-.53	-.42	-.63	.10	-.10
77.70	-.59	-.49	-.70	.10	-.10
78.00	-.57	-.46	-.69	.12	-.12

TABLE IX (cont.)

78.30	-.44	-.33	-.55	.11	-.11
78.60	-.38	-.25	-.51	.13	-.13
78.90	-.42	-.32	-.53	.11	-.11
79.20	-.46	-.38	-.54	.08	-.08
79.50	-.55	-.46	-.65	.09	-.09
79.80	-.36	-.23	-.48	.13	-.13
80.10	-.35	-.20	-.49	.15	-.14
80.40	-.25	-.13	-.36	.11	-.11
80.70	-.34	-.23	-.44	.10	-.10
81.00	-.45	-.30	-.60	.15	-.15
81.30	-.61	-.48	-.73	.13	-.12
81.60	-.45	-.31	-.57	.13	-.13
81.90	-.41	-.31	-.51	.10	-.10
82.20	-.41	-.30	-.52	.11	-.11
82.50	-.35	-.25	-.44	.10	-.10
82.80	-.40	-.33	-.47	.07	-.07
83.10	-.40	-.33	-.48	.08	-.08
83.40	-.61	-.53	-.70	.09	-.09
83.70	-.47	-.38	-.56	.09	-.09
84.00	-.35	-.17	-.52	.17	-.17
84.30	-.40	-.14	-.65	.25	-.25
84.60	-.42	-.20	-.65	.23	-.22
84.90	-.37	-.17	-.56	.20	-.19
85.20	-.36	-.20	-.51	.16	-.16
85.50	-.51	-.39	-.63	.12	-.12
85.80	-.53	-.42	-.63	.10	-.10
86.10	-.43	-.34	-.53	.10	-.10
86.40	-.32	-.24	-.41	.08	-.08
86.70	-.30	-.23	-.36	.07	-.07
87.00	-.36	-.29	-.44	.08	-.08
87.30	-.43	-.34	-.52	.09	-.09
87.60	-.42	-.30	-.53	.12	-.11
87.90	-.61	-.53	-.70	.09	-.09
88.20	-.48	-.27	-.68	.21	-.20
88.50	-.42	-.18	-.65	.24	-.23
88.80	-.45	-.22	-.68	.23	-.23
89.10	-.38	-.15	-.61	.23	-.23
89.40	-.26	-.05	-.46	.21	-.21
89.70	-.44	-.27	-.61	.17	-.17
90.00	-.52	-.36	-.68	.16	-.16

REPRODUCED AT GOVERNMENT EXPENSE

TABLE X
PRINTED OUTPUT OF INSERTION LOSS FOR 10 dB ATTENUATOR USING
SCHOTTKY DIODE DETECTOR

DEVICE UNDER TEST : 10 DB ATTENUATOR

Frequency (GHz)	Insertion Loss (dB)	Attenuator Loss (dB)	Detector Loss (dB)	Reflection Coefficient (dB)	Return Loss (dB)
60.00	-10.75	-10.75			
60.30	-10.47	-10.75			
60.60	-10.13	-10.75			
60.90	-10.19	-10.75			
61.20	-10.16	-10.75			
61.50	-10.38	-10.75			
61.80	-10.46	-10.75			
62.10	-10.34	-10.75			
62.40	-10.63	-10.75			
62.70	-10.62	-10.75			
63.00	-10.54	-10.75			
63.30	-10.42	-10.75			
63.60	-10.46	-10.75			
63.90	-10.47	-10.75			
64.20	-10.65	-10.75			
64.50	-10.63	-10.75			
64.80	-10.65	-10.75			
65.10	-10.69	-10.75			
65.40	-10.93	-10.93	-11.04		
65.70	-10.75	-10.65	-10.85		
66.00	-11.03	-10.94	-11.01	.09	-.09
66.30	-11.12	-11.01	-11.22	.10	-.10
66.60	-10.99	-10.90	-11.09	.10	-.10
66.90	-10.81	-10.71	-10.90	.10	-.10
67.20	-10.91	-10.85	-10.97	.06	-.06
67.50	-11.26	-11.16	-11.37	.11	-.11
67.80	-11.46	-11.34	-11.58	.12	-.12
68.10	-11.34	-11.23	-11.44	.11	-.10
68.40	-11.46	-11.37	-11.55	.09	-.09
68.70	-11.34	-11.27	-11.41	.07	-.07
69.00	-11.46	-11.37	-11.55	.09	-.09
69.30	-11.40	-11.28	-11.51	.12	-.12
69.60	-11.55	-11.42	-11.67	.13	-.13
69.90	-11.49	-11.35	-11.62	.13	-.13
70.20	-10.31	-10.17	-10.45	.14	-.14
70.50	-10.50	-10.41	-10.50	.10	-.10
70.80	-10.28	-10.18	-10.38	.10	-.10
71.10	-10.30	-10.21	-10.39	.09	-.09
71.40	-10.49	-10.41	-10.57	.08	-.08
71.70	-10.44	-10.37	-10.51	.07	-.07
72.00	-10.44	-10.30	-10.58	.14	-.14
72.30	-10.59	-10.46	-10.72	.13	-.13
72.60	-10.61	-10.53	-10.69	.08	-.08
72.90	-10.67	-10.60	-10.75	.07	-.07
73.20	-10.81	-10.71	-10.90	.10	-.10
73.50	-10.82	-10.72	-10.91	.09	-.09
73.80	-10.79	-10.71	-10.87	.08	-.08
74.10	-10.80	-10.74	-10.86	.06	-.06
74.40	-10.82	-10.76	-10.98	.06	-.06
74.70	-10.61	-10.53	-10.70	.08	-.08
75.00	-10.44	-10.31	-10.57	.13	-.13
75.30	-10.58	-10.46	-10.70	.12	-.12
75.60	-10.87	-10.78	-10.96	.09	-.09
75.90	-11.09	-10.99	-11.19	.10	-.10
76.20	-11.02	-10.92	-11.12	.10	-.10
76.50	-11.26	-11.14	-11.39	.13	-.12
76.80	-11.40	-11.27	-11.53	.13	-.13
77.10	-11.53	-11.39	-11.66	.14	-.14
77.40	-11.43	-11.28	-11.58	.15	-.15
77.70	-11.48	-11.32	-11.63	.16	-.16
78.00	-11.65	-11.48	-11.81	.17	-.17

TABLE X (cont.)

78.30	-11.46	-11.30	-11.62	.16	-.16
78.60	-11.52	-11.35	-11.69	.17	-.17
78.90	-11.44	-11.29	-11.60	.16	-.16
79.20	-11.68	-11.53	-11.83	.15	-.15
79.50	-11.89	-11.71	-12.07	.18	-.18
79.80	-11.65	-11.47	-11.82	.17	-.17
80.10	-10.79	-10.61	-10.96	.18	-.17
80.40	-10.81	-10.67	-10.95	.14	-.14
80.70	-10.94	-10.83	-11.06	.12	-.11
81.00	-11.11	-10.99	-11.23	.12	-.12
81.30	-11.05	-10.90	-11.19	.14	-.14
81.60	-10.95	-10.79	-11.10	.16	-.16
81.90	-10.76	-10.64	-10.87	.12	-.12
82.20	-10.83	-10.73	-10.94	.11	-.11
82.50	-10.92	-10.82	-11.01	.10	-.09
82.80	-11.01	-10.92	-11.09	.08	-.08
83.10	-10.99	-10.82	-10.96	.07	-.07
83.40	-11.00	-11.01	-11.15	.07	-.07
83.70	-11.01	-10.92	-11.10	.09	-.09
84.00	-10.73	-10.56	-10.89	.16	-.16
84.30	-10.82	-10.62	-11.02	.20	-.20
84.60	-10.80	-10.61	-10.99	.19	-.19
84.90	-10.82	-10.69	-10.95	.13	-.13
85.20	-10.81	-10.73	-10.89	.08	-.08
85.50	-11.17	-11.10	-11.24	.07	-.07
85.80	-11.27	-11.20	-11.34	.07	-.07
86.10	-11.25	-11.18	-11.31	.07	-.07
86.40	-11.20	-11.13	-11.26	.06	-.06
86.70	-11.25	-11.19	-11.31	.06	-.06
87.00	-11.23	-11.17	-11.29	.06	-.06
87.30	-11.45	-11.37	-11.52	.07	-.07
87.60	-11.42	-11.33	-11.50	.09	-.09
87.90	-11.50	-11.42	-11.59	.08	-.08
88.20	-11.28	-11.11	-11.44	.17	-.17
88.50	-11.28	-11.10	-11.46	.18	-.18
88.80	-11.28	-11.11	-11.46	.18	-.18
89.10	-11.27	-11.10	-11.44	.17	-.17
89.40	-11.29	-11.13	-11.44	.16	-.16
89.70	-11.32	-11.18	-11.46	.14	-.14
90.00	-11.56	-11.42	-11.71	.14	-.14

REPRODUCED BY GOVERNMENT EXPENSE

TABLE XI
 PRINTED OUTPUT OF INSERTION LOSS FOR 20 dB ATTENUATOR USING
 SCHOTTKY DIODE DETECTOR

DEVICE UNDER TEST : 20 DB ATTENUATOR

Frequency (GHz)	Insertion (dB)	Max Ins (dB)	Min Ins (dB)	Max Unc (dB)	Min Unc (dB)
60.00	-20.52	-20.26	-20.78	.26	-.26
60.30	-20.22	-20.10	-20.33	.12	-.12
60.60	-19.93	-19.85	-20.01	.08	-.08
60.90	-19.96	-19.87	-20.06	.10	-.10
61.20	-19.99	-19.84	-20.14	.15	-.15
61.50	-20.17	-20.00	-20.34	.17	-.17
61.80	-20.34	-20.23	-20.45	.11	-.11
62.10	-20.22	-20.11	-20.33	.11	-.11
62.40	-20.45	-20.29	-20.60	.16	-.16
62.70	-20.41	-20.26	-20.55	.15	-.15
63.00	-20.39	-20.26	-20.53	.14	-.13
63.30	-20.33	-20.15	-20.50	.18	-.17
63.60	-20.35	-20.22	-20.48	.13	-.13
63.90	-20.36	-20.22	-20.50	.14	-.14
64.20	-20.55	-20.43	-20.66	.12	-.12
64.50	-20.54	-20.42	-20.65	.12	-.11
64.80	-20.55	-20.54	-20.75	.11	-.10
65.10	-20.69	-20.58	-20.80	.11	-.11
65.40	-20.96	-20.85	-21.06	.10	-.10
65.70	-20.88	-20.78	-20.97	.10	-.10
66.00	-21.02	-20.92	-21.12	.10	-.10
66.30	-21.08	-20.97	-21.20	.11	-.11
66.60	-20.98	-20.87	-21.09	.11	-.11
66.90	-20.97	-20.86	-21.08	.11	-.11
67.20	-21.06	-21.00	-21.12	.06	-.06
67.50	-21.36	-21.27	-21.46	.10	-.10
67.80	-21.51	-21.40	-21.62	.11	-.11
68.10	-21.40	-21.31	-21.50	.10	-.10
68.40	-21.50	-21.41	-21.58	.09	-.09
68.70	-21.50	-21.43	-21.57	.07	-.07
69.00	-21.65	-21.55	-21.75	.10	-.10
69.30	-21.66	-21.54	-21.77	.12	-.12
69.60	-21.84	-21.72	-21.95	.12	-.12
69.90	-21.70	-21.57	-21.83	.13	-.13
70.20	-20.20	-20.07	-20.34	.13	-.13
70.50	-20.34	-20.26	-20.42	.08	-.08
70.80	-20.09	-20.00	-20.18	.09	-.09
71.10	-20.24	-20.15	-20.32	.08	-.08
71.40	-20.30	-20.24	-20.37	.07	-.07
71.70	-20.42	-20.33	-20.52	.09	-.09
72.00	-20.50	-20.36	-20.64	.14	-.14
72.30	-20.59	-20.48	-20.71	.12	-.12
72.60	-20.68	-20.61	-20.76	.07	-.07
72.90	-20.58	-20.51	-20.65	.07	-.07
73.20	-20.84	-20.77	-20.92	.08	-.08
73.50	-21.01	-20.93	-21.09	.08	-.08
73.80	-20.93	-20.86	-21.00	.07	-.07
74.10	-20.92	-20.86	-20.97	.05	-.05
74.40	-20.93	-20.86	-20.99	.06	-.06
74.70	-20.72	-20.66	-20.77	.06	-.06
75.00	-20.32	-20.22	-20.41	.09	-.09
75.30	-20.59	-20.48	-20.69	.11	-.11
75.60	-20.89	-20.81	-20.96	.08	-.08
75.90	-21.09	-21.02	-21.16	.07	-.07
76.20	-21.01	-20.94	-21.08	.07	-.07
76.50	-21.41	-21.32	-21.50	.09	-.09
76.80	-21.53	-21.44	-21.62	.09	-.09
77.10	-21.51	-21.42	-21.60	.09	-.09
77.40	-21.52	-21.42	-21.61	.10	-.10
77.70	-21.63	-21.53	-21.72	.10	-.10
78.00	-21.72	-21.62	-21.82	.10	-.10

TABLE XI (cont.)

78.30	-21.56	-21.46	-21.65	.10	-.10
79.60	-21.44	-21.34	-21.54	.10	-.10
78.90	-21.57	-21.49	-21.65	.08	-.08
79.20	-21.82	-21.75	-21.89	.07	-.07
79.50	-22.03	-21.94	-22.13	.10	-.10
79.80	-21.72	-21.62	-21.82	.10	-.10
80.10	-20.89	-20.78	-21.01	.11	-.11
80.40	-20.85	-20.76	-20.94	.09	-.09
80.70	-21.18	-21.11	-21.26	.08	-.08
81.00	-21.25	-21.17	-21.32	.08	-.08
81.30	-21.22	-21.11	-21.33	.11	-.11
81.60	-21.04	-20.92	-21.15	.12	-.12
81.90	-20.97	-20.89	-21.05	.08	-.08
82.20	-20.94	-20.87	-21.01	.07	-.07
82.50	-20.96	-20.88	-21.03	.07	-.07
82.80	-21.14	-21.09	-21.20	.06	-.06
83.10	-21.09	-21.03	-21.15	.06	-.06
83.40	-21.07	-21.02	-21.13	.06	-.06
83.70	-21.02	-20.95	-21.09	.07	-.07
84.00	-20.74	-20.61	-20.97	.13	-.13
84.30	-20.85	-20.68	-21.02	.17	-.17
84.60	-20.80	-20.62	-20.98	.18	-.18
84.90	-20.80	-20.65	-20.95	.15	-.15
85.20	-20.96	-20.85	-21.06	.10	-.10
85.50	-21.06	-20.98	-21.14	.08	-.08
85.80	-21.06	-20.98	-21.14	.08	-.08
86.10	-21.09	-21.03	-21.15	.06	-.06
86.40	-21.04	-20.98	-21.10	.06	-.06
86.70	-21.10	-21.04	-21.16	.06	-.06
87.00	-21.26	-21.21	-21.32	.05	-.05
87.30	-21.39	-21.32	-21.46	.07	-.07
87.60	-21.27	-21.20	-21.34	.07	-.07
87.90	-21.37	-21.31	-21.44	.07	-.07
88.20	-21.23	-21.07	-21.38	.16	-.16
88.50	-21.13	-20.96	-21.30	.17	-.17
88.80	-21.19	-21.02	-21.36	.17	-.17
89.10	-21.03	-20.86	-21.20	.17	-.17
89.40	-21.35	-21.19	-21.51	.16	-.16
89.70	-21.36	-21.23	-21.50	.13	-.13
90.00	-21.42	-21.29	-21.56	.14	-.13

REPRODUCED AT GOVERNMENT EXPENSE

TABLE XII
 PRINTED OUTPUT OF INSERTION LOSS FOR 30 dB ATTENUATOR USING
 SCHOTTKY DIODE DETECTOR
 DEVICE UNDER TEST : 30 dB ATTENUATOR

Frequency (GHz)	Insertion (dB)	Max Ins (dB)	Min Ins (dB)	Max Unc (dB)	Min Unc (dB)
60.00	-30.24	-29.98	-30.50	.27	-.26
60.30	-29.80	-29.68	-29.92	.12	-.12
60.60	-29.23	-29.15	-29.31	.08	-.08
60.90	-29.86	-29.75	-29.97	.11	-.11
61.20	-29.54	-29.37	-29.70	.16	-.16
61.50	-29.87	-29.68	-30.05	.18	-.18
61.80	-30.19	-30.08	-30.31	.11	-.11
62.10	-29.89	-29.77	-30.00	.11	-.11
62.40	-29.88	-29.72	-30.04	.16	-.16
62.70	-30.12	-29.96	-30.27	.15	-.15
63.00	-30.00	-29.86	-30.14	.14	-.14
63.30	-29.71	-29.54	-29.89	.18	-.18
63.60	-29.81	-29.69	-29.94	.13	-.13
63.90	-30.04	-29.90	-30.18	.14	-.14
64.20	-30.48	-30.36	-30.61	.13	-.13
64.50	-30.20	-30.08	-30.32	.12	-.12
64.80	-30.32	-30.20	-30.43	.12	-.12
65.10	-30.14	-30.03	-30.26	.12	-.11
65.40	-30.82	-30.71	-30.93	.11	-.11
65.70	-30.58	-30.47	-30.68	.10	-.10
66.00	-31.02	-30.92	-31.11	.10	-.10
66.30	-30.79	-30.67	-30.90	.12	-.12
66.60	-30.75	-30.63	-30.86	.12	-.12
66.90	-30.45	-30.34	-30.56	.11	-.11
67.20	-30.72	-30.67	-30.78	.06	-.06
67.50	-31.20	-31.11	-31.30	.10	-.10
67.80	-31.05	-30.93	-31.16	.11	-.11
68.10	-31.08	-30.97	-31.18	.10	-.10
68.40	-31.50	-31.41	-31.59	.09	-.09
68.70	-31.25	-31.17	-31.32	.08	-.08
69.00	-31.44	-31.33	-31.54	.11	-.11
69.30	-31.19	-31.06	-31.31	.12	-.12
69.60	-31.48	-31.37	-31.60	.11	-.11
69.90	-31.81	-31.68	-31.94	.13	-.13
70.20	-29.83	-29.70	-29.96	.13	-.13
70.50	-30.35	-30.27	-30.43	.03	-.08
70.80	-29.72	-29.63	-29.80	.09	-.09
71.10	-29.47	-29.39	-29.54	.08	-.08
71.40	-20.27	-30.21	-30.34	.06	-.06
71.70	-30.31	-30.21	-30.41	.10	-.10
72.00	-30.07	-29.92	-30.22	.15	-.15
72.30	-30.38	-30.26	-30.49	.12	-.12
72.60	-30.37	-30.30	-30.45	.07	-.07
72.90	-30.05	-29.98	-30.11	.07	-.06
73.20	-30.44	-30.37	-30.51	.07	-.07
73.50	-30.47	-30.40	-30.54	.07	-.07
73.80	-30.12	-30.06	-30.18	.06	-.06
74.10	-30.54	-30.49	-30.60	.05	-.05
74.40	-30.42	-30.37	-30.43	.05	-.05
74.70	-30.25	-30.19	-30.30	.05	-.05
75.00	-30.14	-30.06	-30.21	.08	-.08
75.30	-30.18	-30.08	-30.27	.10	-.10
75.60	-30.65	-30.57	-30.73	.08	-.08
75.90	-30.31	-30.74	-30.89	.07	-.07
76.20	-30.66	-30.59	-30.72	.06	-.06
76.50	-31.04	-30.96	-31.11	.08	-.08
76.80	-31.27	-31.21	-31.34	.07	-.07
77.10	-31.36	-31.29	-31.43	.07	-.07
77.40	-31.08	-31.01	-31.16	.08	-.08
77.70	-31.43	-31.36	-31.51	.08	-.08
78.00	-31.35	-31.27	-31.42	.08	-.08

TABLE XII (cont.)

78.30	-31.16	-31.09	-31.24	.08	-.03
78.60	-31.25	-31.17	-31.33	.06	-.08
78.90	-31.60	-31.53	-31.67	.07	-.07
79.20	-31.69	-31.62	-31.75	.06	-.06
79.50	-31.65	-31.57	-31.73	.08	-.08
79.80	-31.76	-31.68	-31.85	.09	-.09
80.10	-29.97	-29.87	-30.07	.10	-.10
80.40	-30.75	-30.64	-30.86	.11	-.11
80.70	-30.77	-30.68	-30.86	.09	-.09
81.00	-30.31	-30.21	-30.41	.10	-.10
81.30	-30.85	-30.77	-30.93	.08	-.08
81.60	-30.40	-30.31	-30.49	.09	-.09
81.90	-30.04	-29.97	-30.10	.07	-.07
82.20	-30.30	-30.23	-30.38	.08	-.08
82.50	-30.19	-30.12	-30.26	.07	-.07
82.80	-30.14	-30.08	-30.20	.06	-.06
83.10	-30.57	-30.51	-30.62	.06	-.06
83.40	-30.95	-30.89	-31.01	.06	-.06
83.70	-30.46	-30.39	-30.52	.06	-.06
84.00	-30.30	-30.19	-30.41	.11	-.11
84.30	-30.13	-29.96	-30.29	.17	-.17
84.60	-30.29	-30.11	-30.48	.19	-.19
84.90	-30.51	-30.34	-30.67	.16	-.16
85.20	-30.51	-30.40	-30.62	.11	-.11
85.50	-30.68	-30.58	-30.77	.09	-.09
85.80	-30.92	-30.83	-31.02	.09	-.09
86.10	-30.59	-30.53	-30.65	.06	-.06
86.40	-30.36	-30.30	-30.42	.06	-.06
86.70	-30.62	-30.57	-30.67	.05	-.05
87.00	-30.68	-30.62	-30.74	.06	-.06
87.30	-30.99	-30.93	-31.05	.06	-.06
87.60	-30.96	-30.89	-31.03	.07	-.07
87.90	-30.93	-30.86	-30.99	.07	-.07
88.20	-30.78	-30.62	-30.93	.15	-.15
88.50	-30.77	-30.60	-30.94	.17	-.17
88.80	-30.85	-30.68	-31.01	.16	-.16
89.10	-30.42	-30.25	-30.59	.17	-.17
89.40	-30.76	-30.60	-30.91	.16	-.15
89.70	-31.19	-31.05	-31.33	.14	-.14
90.00	-31.04	-30.90	-31.19	.14	-.14

REPRODUCED AT GOVERNMENT EXPENSE

TABLE XIII
 PRINTED OUTPUT OF INSERTION LOSS FOR 40 dB ATTENUATOR USING
 SCHOTTKY DIODE DETECTOR

DEVICE UNDER TEST : 40 dB ATTENUATOR

Frequency (GHz)	Insertion (dB)	Max Ins (dB)	Min Ins (dB)	Max Unc (dB)	Min Unc (dB)
60.00	-37.22	-36.96	-37.49	.27	-.27
60.30	-36.43	-36.31	-36.56	.13	-.13
60.60	-37.54	-37.45	-37.62	.09	-.09
60.90	-37.54	-37.44	-37.64	.10	-.10
61.20	-37.94	-37.68	-38.00	.16	-.16
61.50	-38.46	-38.27	-38.64	.19	-.18
61.80	-37.42	-37.32	-37.53	.11	-.11
62.10	-37.24	-37.13	-37.36	.12	-.12
62.40	-37.66	-37.50	-37.81	.16	-.16
62.70	-39.22	-39.07	-39.38	.16	-.15
63.00	-37.31	-37.16	-37.45	.14	-.14
63.30	-41.66	-41.48	-41.84	.18	-.18
63.60	-40.32	-40.19	-40.44	.12	-.12
63.90	-39.04	-38.91	-39.17	.13	-.13
64.20	-38.42	-38.30	-38.53	.12	-.12
64.50	-39.18	-39.07	-39.30	.11	-.11
64.80	-38.65	-38.54	-38.76	.11	-.11
65.10	-37.05	-36.93	-37.16	.11	-.11
65.40	-42.67	-42.56	-42.78	.11	-.11
65.70	-40.04	-39.94	-40.14	.10	-.10
66.00	-40.23	-40.13	-40.32	.10	-.10
66.30	-40.90	-40.78	-41.02	.12	-.12
66.60	-38.93	-38.71	-38.95	.12	-.12
66.90	-40.13	-40.02	-40.25	.11	-.11
67.20	-39.97	-39.91	-40.03	.06	-.06
67.50	-39.45	-39.35	-39.56	.10	-.10
67.80	-41.33	-41.22	-41.44	.11	-.11
68.10	-40.62	-40.52	-40.72	.10	-.10
68.40	-45.85	-45.77	-45.94	.09	-.09
68.70	-39.79	-39.72	-39.87	.07	-.07
69.00	-39.19	-39.09	-39.29	.10	-.10
69.30	-42.70	-42.58	-42.82	.12	-.12
69.60	-39.27	-39.15	-39.39	.12	-.12
69.90	-43.82	-43.69	-43.95	.13	-.13
70.20	-40.97	-40.84	-41.10	.13	-.13
70.50	-39.84	-39.75	-39.93	.09	-.09
70.80	-41.43	-41.35	-41.51	.08	-.08
71.10	-38.42	-38.33	-38.50	.08	-.08
71.40	-40.64	-40.58	-40.70	.06	-.06
71.70	-40.31	-40.21	-40.41	.10	-.10
72.00	-40.26	-40.10	-40.41	.15	-.15
72.30	-42.34	-42.23	-42.46	.12	-.12
72.60	-42.92	-42.85	-42.99	.07	-.07
72.90	-39.39	-39.33	-39.46	.07	-.07
73.20	-38.60	-38.52	-38.67	.07	-.07
73.50	-40.80	-40.73	-40.87	.07	-.07
73.80	-37.59	-37.53	-37.65	.06	-.06
74.10	-38.97	-38.91	-39.03	.06	-.06
74.40	-41.71	-41.65	-41.76	.06	-.06
74.70	-38.56	-38.50	-38.62	.06	-.06
75.00	-42.59	-42.51	-42.66	.07	-.07
75.30	-39.39	-39.28	-39.49	.10	-.10
75.60	-40.61	-40.53	-40.69	.08	-.08
75.90	-40.83	-40.75	-40.90	.07	-.07
76.20	-39.63	-39.57	-39.70	.07	-.07
76.50	-40.57	-40.50	-40.63	.07	-.07
76.80	-43.51	-43.44	-43.57	.07	-.07
77.10	-40.24	-40.18	-40.31	.06	-.06
77.40	-42.82	-42.75	-42.88	.07	-.07
77.70	-42.15	-42.09	-42.21	.06	-.06
78.00	-42.71	-42.63	-42.78	.08	-.08

TABLE XIII (cont.)

78.30	-41.83	-41.76	-41.90	.07	-.07
78.60	-41.32	-41.24	-41.40	.08	-.08
78.90	-41.47	-41.39	-41.55	.08	-.08
79.20	-40.91	-40.85	-40.97	.06	-.06
79.50	-42.93	-42.85	-43.01	.08	-.08
79.80	-40.51	-40.42	-40.60	.09	-.09
80.10	-39.11	-39.01	-39.22	.11	-.11
80.40	-42.76	-42.64	-42.87	.11	-.11
80.70	-40.29	-40.19	-40.39	.10	-.10
81.00	-39.11	-39.03	-39.19	.08	-.08
81.30	-39.98	-39.89	-40.07	.09	-.09
81.60	-38.68	-38.60	-38.77	.09	-.09
81.90	-36.97	-36.90	-37.04	.07	-.07
82.20	-39.74	-39.66	-39.81	.08	-.08
82.50	-42.13	-42.05	-42.22	.08	-.08
82.80	-39.53	-39.47	-39.59	.06	-.06
83.10	-37.89	-37.82	-37.96	.07	-.07
83.40	-39.73	-39.67	-39.80	.07	-.07
83.70	-41.54	-41.47	-41.60	.07	-.07
84.00	-38.34	-38.23	-38.45	.11	-.11
84.30	-41.02	-40.85	-41.19	.17	-.17
84.60	-39.06	-38.88	-39.25	.19	-.19
84.90	-39.80	-39.63	-39.96	.17	-.17
85.20	-39.35	-39.23	-39.47	.12	-.12
85.50	-41.24	-41.15	-41.34	.10	-.09
85.80	-40.05	-39.95	-40.15	.10	-.10
86.10	-39.43	-39.37	-39.49	.06	-.06
86.40	-42.59	-42.53	-42.65	.06	-.06
86.70	-39.13	-39.08	-39.19	.05	-.05
87.00	-41.26	-41.20	-41.32	.06	-.06
87.30	-40.09	-40.03	-40.15	.06	-.06
87.60	-38.97	-38.90	-39.04	.07	-.07
87.90	-41.66	-41.59	-41.72	.06	-.06
88.20	-38.67	-38.51	-38.83	.16	-.16
88.50	-42.76	-42.58	-42.93	.17	-.17
88.80	-37.05	-36.88	-37.22	.17	-.17
89.10	-41.00	-40.82	-41.17	.17	-.17
89.40	-39.58	-39.42	-39.74	.16	-.16
89.70	-39.67	-39.52	-39.81	.15	-.15
90.00	-40.91	-40.66	-40.95	.15	-.15

REPRODUCED AT GOVERNMENT EXPENSE

TABLE XIV
 PRINTED OUTPUT OF INSERTION LOSS FOR 45 dB ATTENUATOR USING
 SCHOTTKY DIODE DETECTOR

DEVICE UNDER TEST : 45 dB ATTENUATOR

Frequency (GHz)	Insertion (dB)	Max Ins (dB)	Min Ins (dB)	Max Unc (dB)	Min Unc (dB)
60.00	-37.83	-37.56	-38.09	.27	-.26
60.30	-37.79	-37.65	-37.92	.13	-.13
60.60	-39.42	-39.33	-39.51	.09	-.09
60.90	-41.00	-40.91	-41.09	.09	-.09
61.20	-40.20	-40.04	-40.36	.16	-.16
61.50	-41.27	-41.09	-41.45	.18	-.18
61.80	-39.82	-39.71	-39.92	.11	-.11
62.10	-39.88	-39.77	-39.99	.11	-.11
62.40	-38.03	-37.87	-38.18	.16	-.16
62.70	-39.57	-39.42	-39.72	.15	-.15
63.00	-39.00	-38.86	-39.14	.14	-.14
63.30	-40.61	-40.43	-40.79	.18	-.18
63.60	-39.29	-39.16	-39.42	.13	-.13
63.90	-41.77	-41.64	-41.91	.14	-.13
64.20	-42.84	-42.72	-42.96	.12	-.12
64.50	-42.59	-42.48	-42.70	.11	-.11
64.80	-39.51	-39.40	-39.62	.11	-.11
65.10	-41.11	-41.00	-41.23	.12	-.11
65.40	-42.73	-42.62	-42.84	.11	-.11
65.70	-43.59	-43.49	-43.69	.10	-.10
66.00	-39.76	-39.66	-39.86	.10	-.10
66.30	-39.08	-38.96	-39.20	.12	-.12
66.60	-40.64	-40.52	-40.76	.12	-.12
66.90	-42.27	-42.15	-42.38	.12	-.12
67.20	-45.16	-45.10	-45.21	.06	-.06
67.50	-42.68	-42.59	-42.78	.10	-.10
67.80	-42.27	-42.16	-42.37	.11	-.11
68.10	-44.10	-44.00	-44.19	.10	-.10
68.40	-40.12	-40.03	-40.20	.09	-.09
68.70	-40.24	-40.17	-40.31	.07	-.07
69.00	-44.08	-43.98	-44.19	.11	-.11
69.30	-43.90	-43.78	-44.03	.13	-.13
69.60	-43.33	-43.21	-43.44	.12	-.12
69.90	-44.42	-44.29	-44.55	.13	-.13
70.20	-39.53	-39.40	-39.66	.13	-.13
70.50	-38.50	-38.42	-38.59	.08	-.08
70.80	-39.40	-39.31	-39.49	.09	-.09
71.10	-39.27	-39.20	-39.33	.07	-.07
71.40	-41.83	-41.76	-41.89	.06	-.06
71.70	-39.43	-39.33	-39.53	.10	-.10
72.00	-41.71	-41.56	-41.86	.15	-.15
72.30	-41.03	-40.91	-41.15	.12	-.12
72.60	-40.44	-40.37	-40.51	.07	-.07
72.90	-43.16	-43.09	-43.23	.07	-.07
73.20	-42.30	-42.23	-42.38	.07	-.07
73.50	-45.95	-45.88	-46.01	.07	-.07
73.80	-41.92	-41.86	-41.98	.06	-.06
74.10	-43.73	-43.67	-43.78	.05	-.05
74.40	-41.41	-41.36	-41.46	.05	-.05
74.70	-43.15	-43.09	-43.21	.06	-.06
75.00	-41.82	-41.75	-41.90	.08	-.08
75.30	-39.32	-39.22	-39.43	.10	-.10
75.60	-41.46	-41.37	-41.54	.09	-.09
75.90	-44.40	-44.33	-44.46	.07	-.07
76.20	-40.29	-40.22	-40.35	.06	-.06
76.50	-43.42	-43.35	-43.49	.07	-.07
76.80	-42.80	-42.73	-42.86	.07	-.07
77.10	-43.29	-43.22	-43.35	.06	-.06
77.40	-43.88	-43.80	-43.95	.07	-.07
77.70	-41.21	-41.14	-41.27	.07	-.07
78.00	-43.67	-43.60	-43.75	.07	-.07

REPRODUCED AT GOVERNMENT EXPENSE

TABLE XIV (cont.)

79.30	-41.23	-41.16	-41.31	.07	-.07
78.60	-42.53	-42.45	-42.61	.08	-.08
79.90	-41.87	-41.79	-41.94	.07	-.07
79.20	-46.19	-46.13	-46.24	.06	-.06
79.50	-41.43	-41.36	-41.50	.07	-.07
79.80	-41.46	-41.37	-41.55	.09	-.09
80.10	-39.11	-39.01	-39.22	.10	-.10
80.40	-38.16	-38.05	-38.27	.11	-.11
80.70	-41.42	-41.33	-41.51	.09	-.09
81.00	-40.92	-40.83	-41.01	.09	-.09
81.30	-42.23	-42.13	-42.33	.10	-.10
81.60	-40.43	-40.34	-40.52	.09	-.09
81.90	-40.50	-40.44	-40.57	.06	-.06
82.20	-41.92	-41.84	-42.00	.08	-.08
82.50	-40.95	-40.87	-41.03	.08	-.08
82.80	-41.16	-41.09	-41.23	.07	-.07
83.10	-41.82	-41.74	-41.89	.07	-.07
83.40	-41.84	-41.78	-41.90	.06	-.06
83.70	-42.96	-42.90	-43.02	.06	-.06
84.00	-39.16	-39.05	-39.26	.11	-.11
84.30	-40.14	-39.97	-40.30	.17	-.16
84.60	-44.16	-43.97	-44.35	.19	-.19
84.90	-42.29	-42.12	-42.45	.16	-.16
85.20	-42.06	-41.95	-42.18	.12	-.12
85.50	-42.33	-42.24	-42.43	.10	-.09
85.80	-44.96	-44.86	-45.06	.10	-.10
86.10	-40.13	-40.07	-40.19	.06	-.06
86.40	-41.60	-41.54	-41.65	.06	-.06
86.70	-42.41	-42.36	-42.47	.06	-.06
87.00	-43.08	-43.03	-43.14	.06	-.06
87.30	-45.15	-45.08	-45.22	.07	-.07
87.60	-42.12	-42.04	-42.20	.08	-.08
87.90	-41.58	-41.52	-41.65	.06	-.06
88.20	-41.85	-41.70	-42.00	.15	-.15
88.50	-40.00	-39.83	-40.17	.17	-.17
88.80	-40.18	-40.01	-40.35	.17	-.17
89.10	-39.14	-38.97	-39.31	.17	-.17
89.40	-42.52	-42.36	-42.68	.16	-.16
89.70	-42.38	-42.23	-42.52	.14	-.14
90.00	-42.61	-42.47	-42.75	.14	-.14

REPRODUCED AT GOVERNMENT EXPENSE

LIST OF REFERENCES

1. Leoussis, G. S., Implementation of an Automated Millimeter-Wave Scalar Network Analyzer, Master's Thesis, Naval Postgraduate School, Monterey, California, December 1982.
2. Hughes Aircraft Company, Microwave Products Division, Millimeter-Wave Products 1985 Catalog, Hughes Aircraft Company, Microwave Products Division, Torrance, California, 1985.
3. Knorr, J. B., "Scattering Analysis of a Millimeter-Wave Scalar Network Analyzer," IEEE Transactions On Microwave Theory and Techniques, v. MTT-32, no. 2, pp. 183-190, February 1984.
4. Gatsos, E. D., Reflection and Insertion Loss Software Developments for an Automated Scalar Network Measurement System, Master's Thesis, Naval Postgraduate School, Monterey, California, June 1983.
5. M/A-COM Millimeter Products, Inc., Millimeter Wave Products, M/C-COM Baytron, Inc., Burlington, Massachusetts, 1985.

INITIAL DISTRIBUTION LIST

	No. Copies
1. Defense Technical Information Center Cameron Station Alexandria, Virginia 22304-6145	2
2. Library, Code 0142 Naval Postgraduate School Monterey, California 93943-5002	2
3. Department Chairman, Code 62 Department of Electrical Engineering Naval Postgraduate School Monterey, California 93943	1
4. Professor Jeffrey B. Knorr, Code 62K0 Department of Electrical Engineering Naval Postgraduate School Monterey, California 93943	2
5. Lieutenant David E. Falkner, USN 4012 Arthington Boulevard Indianapolis, Indiana 46226	2

END

2-87

DTIC