

AD-A174 875

USAFOEHL REPORT

86-072EH0021HGA



**AIR FORCE ASBESTOS GUIDANCE FOR RATING AND  
ASSESSING DAMAGE AND EXPOSURE (GRADE)  
SYSTEM**

**LAURENCE P. PAZYRA, MAJOR, USAF, BSC**

**August 1986**

**Final Report**

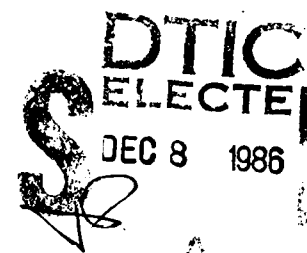

**Distribution unlimited: approved for public release**

DTIC FILE COPY

**USAF Occupational and Environmental Health Laboratory  
Aerospace Medical Division (AFSC)  
Brooks Air Force Base, Texas 78235-5501**

86 12 08 014

**BLANK PAGES  
IN THIS  
DOCUMENT  
WERE NOT  
FILMED**

NOTICES

When Government drawings, specifications, or other data are used for any purpose other than a definitely related Government procurement operation, the Government thereby incurs no responsibility nor any obligation whatsoever. The fact that the Government may have formulated, or in any way supplied the said drawing, specifications, or other data, is not to be regarded by implication, or other-wise, as in any manner licensing the holder or any other person or corporation; or conveying any rights or permission to manufacture, use, or sell any patented invention that may in any way be related thereto.

The mention of trade names or commercial products in this publication is for illustration purposes and does not constitute endorsement or recommendation for use by the United States Air Force.

Do not return this copy. Retain or destroy.

Air Force installations may direct requests for copies of this report to: USAF Occupational and Environmental Health Laboratory (USAFOEHL) Library, Brooks AFB, TX 78235-5501.

Other Government agencies and their contractors registered with the DTIC should direct requests for copies of this report to: Defense Technical Information Center (DTIC), Cameron Station, Alexandria VA 22314.

Non-Government agencies may purchase copies of this report from: National Technical Information Service (NTIS), 5285 Port Royal Road, Springfield VA 22161

The Public Affairs Office has reviewed this report, and it is releasable to the National Technical Information Service, where it will be available to the general public, including foreign nations.

This report has been reviewed and is approved for publication.

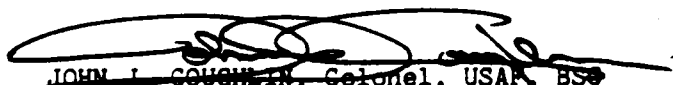
  
JOHN I. COUGHLIN, Colonel, USAF, BSC  
Commander

Reviewed By:

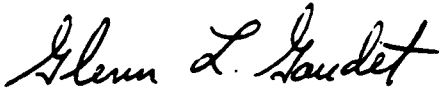
  
GLENN L. GAUDET, Lt Col, USAF, BSC  
Chief, Industrial Hygiene Branch

Prepared By:

  
LAURENCE PAZYRA, Major, USAF, BSC  
Consultant, Industrial Hygiene Engineer

  
KAREN A. MEIER, Colonel, USAF, NC  
Chief, Environmental Health Branch

**REPORT DOCUMENTATION PAGE**

1a. REPORT SECURITY CLASSIFICATION Unclassified			1b. RESTRICTIVE MARKINGS			
2a. SECURITY CLASSIFICATION AUTHORITY N/A			3. DISTRIBUTION / AVAILABILITY OF REPORT Distribution is unlimited; approved for public release			
2b. DECLASSIFICATION / DOWNGRADING SCHEDULE N/A			5. MONITORING ORGANIZATION REPORT NUMBER(S)			
4. PERFORMING ORGANIZATION REPORT NUMBER(S) USAF O EHL Report 86-072EH0021HGA			7a. NAME OF MONITORING ORGANIZATION			
6a. NAME OF PERFORMING ORGANIZATION USAF Occupational and Environmental Health Laboratory		6b. OFFICE SYMBOL (if applicable) ECH	7b. ADDRESS (City, State, and ZIP Code)			
6c. ADDRESS (City, State, and ZIP Code) Same as 6a			9. PROCUREMENT INSTRUMENT IDENTIFICATION NUMBER			
8a. NAME OF FUNDING / SPONSORING ORGANIZATION		8b. OFFICE SYMBOL (if applicable)	10. SOURCE OF FUNDING NUMBERS			
8c. ADDRESS (City, State, and ZIP Code)			PROGRAM ELEMENT NO.	PROJECT NO.	TASK NO.	WORK UNIT ACCESSION NO.
11. TITLE (Include Security Classification) Air Force Asbestos Guidance for Rating and Assessing Damage and Exposure (GRADE) System (U)						
12. PERSONAL AUTHOR(S) Laurence P. Pazyra, Major, USAF, BSC						
13a. TYPE OF REPORT Final		13b. TIME COVERED FROM TO		14. DATE OF REPORT (Year, Month, Day) August 1986		15. PAGE COUNT 79
16. SUPPLEMENTARY NOTATION						
17. COSATI CODES			18. SUBJECT TERMS (Continue on reverse if necessary and identify by block number)			
FIELD	GROUP	SUB-GROUP	Asbestos	Risk Assessment	Asbestos Rating	
			Asbestos Abatement	Hazard Assessment		
			Versar, Inc.	Abatement Priority		
19. ABSTRACT (Continue on reverse if necessary and identify by block number) This report was written in response to a request from HQ USAF/SGPA for a method by which asbestos abatement could be prioritized AF wide. The Asbestos GRADE system is based upon the asbestos risk assessment and abatement prioritization system developed by Versar, Inc. of Springfield VA. Our method provides a means by which the Air Force, Command, or base officials may prioritize asbestos abatement for sprayed-on, trowelled-on, or damaged friable asbestos-containing material (ACM). Also, included are recommended survey and bulk sampling procedures, a rating and scoring checklist with individual factor definitions, recommended Rating vs Priority follow-up actions, and 15 examples on the use of the rating and scoring checklist.						
20. DISTRIBUTION / AVAILABILITY OF ABSTRACT <input type="checkbox"/> UNCLASSIFIED/UNLIMITED <input checked="" type="checkbox"/> SAME AS RPT. <input type="checkbox"/> DTIC USERS				21. ABSTRACT SECURITY CLASSIFICATION Unclassified		
22a. NAME OF RESPONSIBLE INDIVIDUAL Laurence P. Pazyra, Maj, USAF, BSC			22b. TELEPHONE (Include Area Code) (512) 536-3214		22c. OFFICE SYMBOL USAF O EHL/ECH	

## ACKNOWLEDGMENT

Col (Dr) Bruce Poitrast and Capt Robert Elves were instrumental in the review of methodologies and the completion of the final GRADE product. The GRADE checklist and the multiple regression model are modified versions of those developed by Versar, Inc. of Springfield, Virginia. We wish to thank Dr Ouellette, one of the authors of the methodology and Vice President of Corporate Development, for granting us permission to modify and use Versar's asbestos assessment and prioritization system. His cooperation and that of the Versar Corporation in this matter is appreciated.

Contents

	Page
DD Form 1473	i
Acknowledgement	iii
I. INTRODUCTION	1
II. DISCUSSION	1
III. CONCLUSIONS AND RECOMMENDATIONS	3
REFERENCES	5
APPENDIX	
A Excerpts from the Dec 85 Versar, Inc. Paper	7
B Survey, Bulk Sampling, Asbestos GRADE and Priority Procedures	13
1. Survey Procedures	15
2. Bulk Sampling Recommendations	21
3. Asbestos GRADE Checklist	27
4. Rating Interval vs Priority	37
C Evaluation Examples	41
Distribution List	75

DTIC  
COPY  
INSPECTED  
1

Handwritten notes and a large handwritten 'A' are present in the lower-left quadrant of the page.

## I. INTRODUCTION

A. Purpose: To provide a scoring and rating checklist and procedure for assessing damage and potential for damage and resultant potential exposure conditions associated with the presence of sprayed-on, trowelled-on, or damaged friable asbestos-containing material (ACM), and to recommend abatement priorities based on relative rating (R) results. Also included are examples of how the checklist is used to score and rate "assessment cells".

B. Problem: In September 1985, HQ USAF/SGPA requested USAFOEHL conduct a study to review the currently known risk analysis methodologies such as the Ferris Index, the Navy Method, etc., and to recommend adopting one of the existing systems or developing a new one to suit Air Force needs. They wanted the methodology to be clear, reproducible and representative of the potentially hazardous conditions created by the presence of friable ACM so that it could be used to prioritize asbestos abatement activities Air Force-wide. In January 1986, we recommended to HQ USAF/SGPA (Air Staff) the adoption of the risk analysis method developed by Versar, Inc. In our 10 February 1986 letter, at the request of the Air Staff, we modified the Versar, Inc. method by further defining the damage (risk) and exposure factors, and by slightly modifying their multiple regression equation. Although these changes were made, the mechanics and the intent of the model remained the same.

C. Scope: This report includes: (1) a recommended survey procedure, (2) a damage and exposure scoring and rating checklist for sprayed-on, trowelled-on, or damaged friable ACM, and (3) examples on the use of the checklist. In regard to undamaged friable (e.g., intact pipe insulation) and nonfriable ACM, the checklist may be used to document area conditions and bulk and air sample collection locations and results. This information would be useful as historical records and could be used for project programming and cost estimation.

## II. DISCUSSION

Currently, there are six methodologies for rating the potential health hazard associated with the presence of friable ACM. They are the Ferris,<sup>1</sup> the Canadian Ministry,<sup>1</sup> the Navy,<sup>2</sup> the Environmental Protection Agency (EPA) Region VII,<sup>3</sup> the Versar, Inc.,<sup>4</sup> and the EPA "Purple Book"<sup>5</sup> methods. All but the "Purple Book" and Canadian methods numerically rate the hazard and recommend management actions. The Versar, Inc. method was published after the EPA's "Purple Book." For the Navy, Canadian, and the Region VII methods, the EPA "Purple Book" states "Assigning numerical ratings to assessment factors and combining them into a single score cannot be recommended".

All the above mentioned methodologies address two basic sets of factors: (1) current condition of ACM (type of material, degree of damage, etc.) and (2) potential for fiber release and exposure (air movement in area, activity, accessibility, etc.). As stated above, the latest EPA publication, the "Purple Book," did not recommend the use of a numerical rating system. But, we surmised that to prioritize asbestos abatement activities Air Force-wide, we had to adopt or develop a numerical rating system. After examining the six methods, we decided to adopt the one developed by Versar, Inc. It was chosen because (1) it included all the factors from the other methods and more,

(2) the method was developed through field testing, and (3) it included a regression equation that could be used to numerically rate both the apparent and the potential for damage and potential exposure conditions.

To develop the regression equation, Versar, Inc. first defined hazard in terms of damage (D) and exposure (E). Then they subdivided these two factors even further and finally weighted each (D has six factors and E has nine factors). A rating sheet was made and used in a field test. This field test involved scoring and rating damage and exposure for each of 166 areas in a school system's buildings and plotting the D and E summed values on a "hazard" graph (E on the X axis and D on the Y axis). Then Versar, Inc. asbestos experts arbitrarily divided the scatter plot into six areas and assigned hazard ranks; 1 for high hazard to 6 for low hazard. The experts "empirically determined that parabolic substitution curves provided the greatest discriminatory power for classifying each hazard into one of six meaningful zones," i.e., 1 = 6. Lastly, Versar, Inc. used their rating form and graph model in another field test involving 84 areas to see if their method was consistent with the opinion of their experts. According to their statistics, the results of the ratings correlated well with their experts' opinion and thus supported their contention that the damage and exposure numerical indicators allow defining of a hazard into one of six management action categories (see Appendix A). We decided to adopt part of the Versar, Inc. system by using their multiple regression model and by adding damage and exposure factor definitions or explanations to their original scoring checklist. These explanations or definitions would help ensure continuity of assessment ratings which would be needed for Air Force utilization.

The hazard values (H) from Versar's original multiple regression model ranged from -4 to +7 ( i.e.,  $-4 < H < +7$  ) (see equation 1 below).

$$H = 8.0324 - (0.1683 * D) + (0.1693 * E) \quad (\text{Eqn 1})$$

where

H = Hazard

D = Sum of the damage factors (numerical range is  $1 \leq D \leq 28$ ).

E = Sum of the exposure factors (numerical range is  $5 \leq E \leq 43$ ).

These calculated H values can be grouped into intervals to correspond with the management action categories that Versar, Inc. used to develop their prioritization methodology (see Appendix A). For example, H values less than 2 may be considered in management action category 1 (i.e.  $H < 2$  is category 1,  $2 \leq H < 3$  is category 2, etc.). A simplified plot of this is shown in Figure 1.

The Air Force Engineering Service Center suggested we modify the H range to make all possible values positive numbers. We changed the range by adding the number four to each side of the expression.

$$\begin{array}{l} -4 < H < +7 \quad (\text{original H range}) \\ -4 + 4 < H + 4 < +7 + 4 \quad (\text{add 4 to the expression}) \end{array}$$

$$\text{Let } R = H + 4$$

$$0 < R < 11 \quad (\text{revised range})$$



The revised range contains all positive numbers and also changes the mathematical model to look like equation 2.

$$R = 12.0324 - (0.1683 * D) - (0.1693 * E) \quad (\text{Eqn 2})$$

Figure 1 compares the new R to Versar's original H interval values.

As mentioned above, in developing their model Versar defined six hazard zones based upon their expertise in asbestos assessment. Since the multiple regression model for calculating H correlated well with their empirically determined parabolic curves which separated each of their six hazard zones, we decided to forego the use of the graph and curves and to use a modified version of Versar's statistical model as our numerical prioritizing methodology. We decided against using the recommended management action guidance as an indication for asbestos abatement action. Instead, we opted to categorize action by recommending priority be given to those "assessment cells" or areas falling within a certain R range. Thus, we made the rating system a means for prioritizing asbestos abatement as opposed to a means for requiring abatement. According to the present Air Force, EPA, and Occupational Safety and Health Act (OSHA) regulations, air sampling results are the only basis upon which one is required to institute engineering or abatement activities to reduce asbestos exposure or hazard.

Appendix B contains the survey procedure (Section 1), bulk sampling recommendations (Section 2), the modified Versar, Inc. Air Force Asbestos GRADE checklist including both the one and five page versions (Section 3), and a table comparing R intervals to priority (Section 4).

The survey procedure is based upon the guidance in the EPA "Purple Book." The EPA procedure was slightly modified to take into account building population or use, material friability, and material condition. Portions of the bulk sampling recommendations are from the USAFOEHL Sampling Guide. To acquaint the user with our modified Asbestos GRADE checklist, 15 example evaluations are included in Appendix C. These examples cannot take the place of actual field conditions, but they highlight the information required to accomplish a building survey and an asbestos GRADE evaluation.

### III. CONCLUSIONS and RECOMMENDATIONS

1. The Versar Inc. methodology was found to be the most appropriate asbestos rating system upon which the Air Force could model its asbestos prioritization system.
2. A reassessment of all areas with sprayed-on, trowelled-on, or damaged friable asbestos-containing material should be accomplished every six months per the EPA "Purple Book." Air samples should be collected according to the R ratings listed in Section 4 of Appendix B.
3. Section 1 of Appendix B contains our recommended survey procedure.
4. The Asbestos GRADE system is limited to friable ACM and is intended for use as an Air Force-wide asbestos abatement prioritization tool. It does not replace air sampling as the primary means of assessing asbestos exposure.

VERSAR REGRESS.  $H = 8.0324 - (0.1683 * D) - (0.1693 * E)$   
 $-3.9599 \leq H \leq 7.0176$

AF GRADE  $R = 12.0324 - (0.1683 * D) - (0.1693 * E)$   
 $0.0401 \leq R \leq 11.0176$

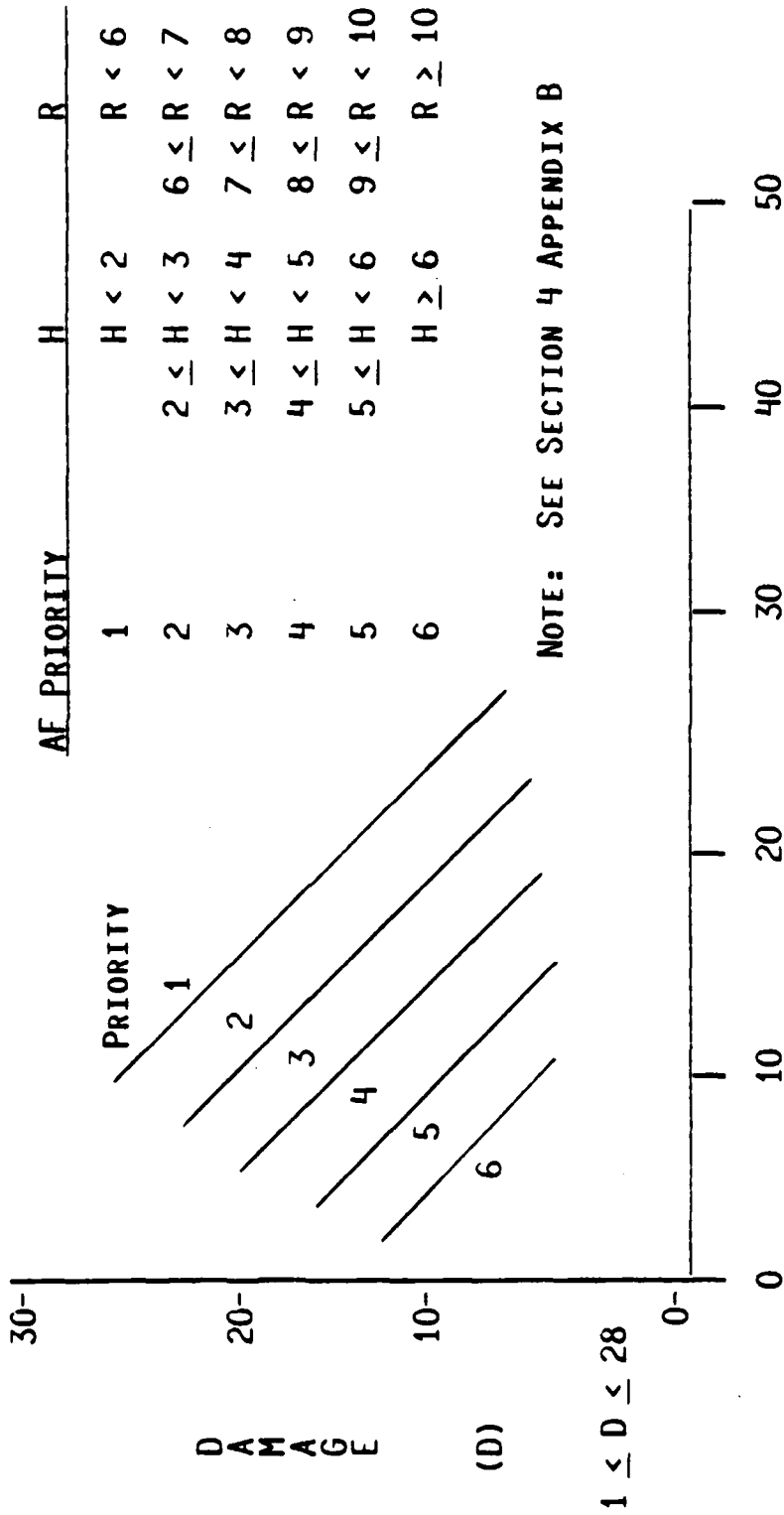

EXPOSURE FACTORS (E)  $5 \leq E \leq 43$

FIGURE 1. AF PRIORITY VS VERSAR H VS AF GRADE R

## References

1. Lecture, Topic: Risk Assessment of Asbestos in Public Buildings. Delivered by Dorothy L. Stensel, at the American Industrial Hygiene Conference, Las Vegas NV (22 May 1985) (includes the Ferris and Canadian Ministry methods).
2. Lory E. E., D. C. Coin, Management Procedure for Assessment of Friable Asbestos Insulating Material. Civil Engineering Laboratory Naval Construction Battalion Center, Port Hueneme CA, February 1981.
3. EPA Region VII, October 1982, Asbestos Exposure Assessment in Buildings, Inspection Manual (Revised)
4. Ouellette, R. P., A. Garte, and W. C. Thompson, Jr., "Asbestos Risk/Exposure Assessment and Hazard Prioritization System," Occupational Health and Safety, Vol 55, No. 11, November 1985. (Note: This article is an abridged version of the one submitted by Versar, Inc. Dr Ouellette was contacted in Dec 85 to obtain the full text including changes made since the article was submitted.)
5. EPA 560/5-85-024, June 1985, Guidance for Controlling Asbestos-Containing Materials in Buildings. "Purple Book"
6. Interview, Topic: Asbestos Risk Assessment with Dr Ouellette, Versar, Inc., Springfield VA (12 December 1985 and 26 March 1986).

APPENDIX A

Excerpts from the Versar, Inc. Abatement  
Prioritization System

**TABLE 1**

**Exposure Risk Assessment/Evaluation**

Client: \_\_\_\_\_ Date: \_\_\_\_\_ Project No. \_\_\_\_\_  
 Site: \_\_\_\_\_ Inspector \_\_\_\_\_ Evaluator: \_\_\_\_\_  
 \_\_\_\_\_ Area Identification No.: \_\_\_\_\_  
 \_\_\_\_\_ Field Sample No.: \_\_\_\_\_

**DAMAGE**

**Physical**  
 H \_\_\_\_\_ (5)  
 M \_\_\_\_\_ (4)  
 L \_\_\_\_\_ (2)  
 N \_\_\_\_\_ (0)

**Water**  
 Y \_\_\_\_\_ (3)  
 N \_\_\_\_\_ (0)

**Proximity to Items Repair**  
 <1 ft \_\_\_\_\_ (3)  
 >1-5 ft \_\_\_\_\_ (2)  
 >5 ft \_\_\_\_\_ (0)

**Type of Material**  
 Pipe \_\_\_\_\_ (0)  
 Boiler \_\_\_\_\_ (1)  
 HVAC \_\_\_\_\_ (3)  
 Ceilings/Walls \_\_\_\_\_ (4)  
 Other \_\_\_\_\_ (0-4)

**Potential for Contact**  
 <10 ft >10 ft  
 H \_\_\_\_\_ (8) H \_\_\_\_\_ (5)  
 M \_\_\_\_\_ (5) M \_\_\_\_\_ (3)  
 L \_\_\_\_\_ (2) L \_\_\_\_\_ (0)

**Asbestos Content**  
 >1-30% \_\_\_\_\_ (1)  
 >30-50% \_\_\_\_\_ (3)  
 >50% \_\_\_\_\_ (5)

TOTAL \_\_\_\_\_  
 [max 28 min 1]

Comments: \_\_\_\_\_  
 \_\_\_\_\_  
 \_\_\_\_\_  
 \_\_\_\_\_  
 \_\_\_\_\_  
 \_\_\_\_\_  
 \_\_\_\_\_  
 \_\_\_\_\_

**EXPOSURE FACTORS**

**Friable**  
 H \_\_\_\_\_ (6)  
 M \_\_\_\_\_ (3)  
 L \_\_\_\_\_ (1)  
 N \_\_\_\_\_ (0)

**ACM Area**  
 <10 ft<sup>2</sup> \_\_\_\_\_ (0)  
 10-100 ft<sup>2</sup> \_\_\_\_\_ (1)  
 >100-1000 ft<sup>2</sup> \_\_\_\_\_ (2)  
 >1000 ft<sup>2</sup> \_\_\_\_\_ (3)

**Walls**  
 Rough \_\_\_\_\_ (4)  
 Pitted \_\_\_\_\_ (3)  
 Mod. Texture \_\_\_\_\_ (2)  
 Smooth \_\_\_\_\_ (1)

**Ventilation - Vent near friable material**  
 Y \_\_\_\_\_ (1)  
 N \_\_\_\_\_ (0)  
 Intake \_\_\_\_\_ (4)  
 Outflow \_\_\_\_\_ (2)

**Air Movement**  
 H \_\_\_\_\_ (5)  
 M \_\_\_\_\_ (2)  
 L \_\_\_\_\_ (0)

**Activity**  
 H \_\_\_\_\_ (5)  
 M \_\_\_\_\_ (2)  
 L \_\_\_\_\_ (0)

**Floor**  
 Carpet \_\_\_\_\_ (4)  
 Tile \_\_\_\_\_ (2)  
 Concrete \_\_\_\_\_ (1)  
 Other \_\_\_\_\_ (1-4)

**Barriers**  
 Suspended Ceiling \_\_\_\_\_ (1)  
 Encapsulation \_\_\_\_\_ (2)  
 Railing \_\_\_\_\_ (3)  
 None \_\_\_\_\_ (4)  
 Other \_\_\_\_\_ (1-4)

**Population**  
 1-9 \_\_\_\_\_ (1)  
 10-200 \_\_\_\_\_ (2)  
 >200-500 \_\_\_\_\_ (3)  
 >500-1000 \_\_\_\_\_ (4)  
 >1000 \_\_\_\_\_ (5)  
 TOTAL \_\_\_\_\_

[max 43 min 5]

TABLE 3

STATISTICAL ANALYSIS

Multiple Regression

Model:  $H = 0.1683D + 0.1693E + 8.0324$

Where

H = hazard, D = Damage, E = Exposure

N = 84 points

$R^2 = 0.749$

F = 122.4707

ANOVA

<u>Source</u>	<u>SS</u>	<u>DF</u>	<u>MS</u>
Regression	103.97	2	51.985
Error	34.8065	82	0.4245
Total SS	138.7765	83	

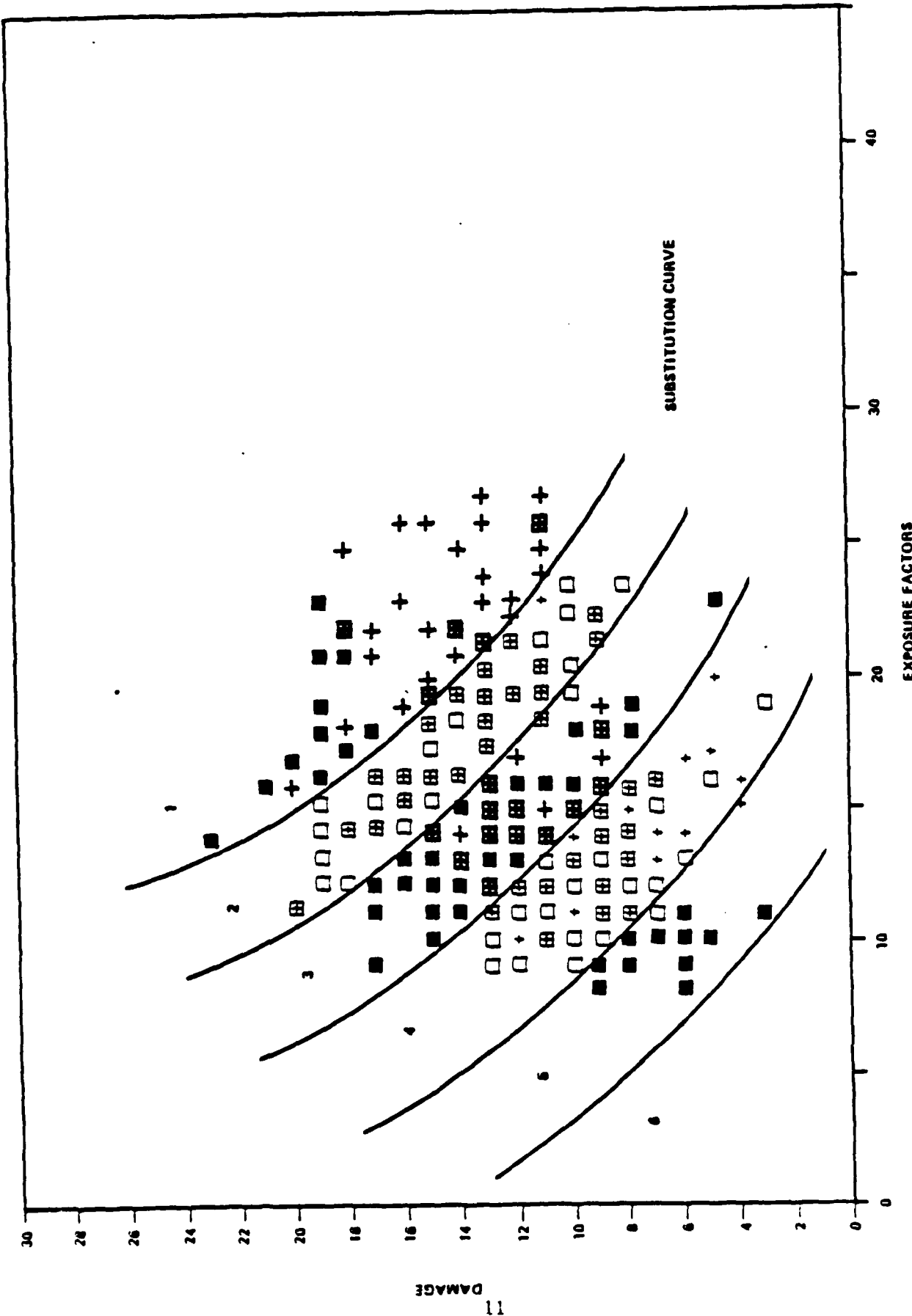

+ STUDENT AREAS

TABLE 4  
VERSAR HAZARD GRAPH

1) NON STUDENT AREAS

... ..

A mechanical and mathematical scoring, ranking, and prioritization scheme is not the full answer. Many external factors and conditions ranging from political considerations to socio-economic issues, to physical arrangements, to existing programs all contribute to shape a realistic program. The methods described in this article are a powerful adjunct to the normal decision-making process. They are not the only nor the full answer to the difficult problems of long-range planning. Still the hazard graph can be divided into six regions, defining levels of increasing concern (from 6 to 1) and possibly the sets of management actions that could be undertaken. In the example presented, the management actions corresponding to hazard ranks 1 to 6 are as follows (Table 4):

1. Immediate Removal. This area of the graph represents the major concern. The situation is such in terms of both damage and exposure potential to warrant immediate removal in spite of the large potential for fiber release during abatement.
2. Removal as Soon as Possible. Like the area above, this is a guide to management that the asbestos containing material should be removed as soon as possible, not waiting for the normal repair and maintenance cycle. In a school, for instance, removal should be accomplished during the summer or during recess periods. In a commercial building, it can be accomplished at night over a period of days. Prior to actual removal, it may be wise to limit access to that part of the building.
3. Planned Removal. The hazard involved in these areas is such that removal should take place as part of the normal maintenance and repair cycle of a facility. This approach minimizes cost and disturbance.
4. Repair. The most damaged areas should be repaired by proper covering, encapsulation or replacement.
5. Monitoring. Periodic monitoring of these areas should be planned to insure that no further damage takes place.
6. No Immediate Action. These cases show little damage to structure and little exposure. In most cases the material is well protected so that fiber release is very unlikely. No current action should be undertaken.

In using management actions two through six, a monitoring program should be installed to keep maintenance and management personnel advised of any changes that may increase the area hazard potential. It should be noted that an area is not rated by this system if no asbestos is present. Removal is the ultimate solution in a complete asbestos abatement program. Often the final step cannot be applied to all facilities simultaneously or immediately. As mentioned earlier, the set of management actions attendant to each region of the prioritization hazard graph is only suggestive of the levels of concern and is a guide to decisions under uncertainty due to external pressures and specific considerations.



## APPENDIX B

### Section

1. Survey Procedures (see Figure B-1)
2. Bulk Sampling Recommendations
3. Asbestos GRADE Checklist
  - a. One Page Checklist
  - b. Five Page Checklist
4. Rating Interval versus Priority

APPENDIX B

Section 1

Survey Procedures

A. Survey Procedures (Refer to Figure B-1)

1. Set Priority. Identify: (a) residential quarters which may be used to house young children (e.g., family housing and transient family quarters), (b) child care facilities, (c) other facilities populated or used by children or young adults (e.g., youth centers, schools, theaters, etc.), (d) base quarters, (e) medical facilities that provide patient care, and (f) other base facilities. The priority, a-f, is based on the age of the personnel and the occupancy time. Review building records, drawings, and specifications by priority.
2. Locate asbestos-containing materials (ACM) specified in building records, drawings, and specifications and document the presence or absence of ACM. Inspect and assess buildings according to the priority listing above.
3. Do the buildings contain friable materials? If not, go to paragraph 4. If yes, is the friable material sprayed-on, trowelled-on, or damaged (i.e., damaged and exposed friable material)? If no, go to paragraph 5. If yes, divide each floor of the building(s) into assessment cells. To do this, mark the location of all sprayed-on, trowelled-on, or damaged friable material on each floor plan. Examine the GRADE checklist (Section 3 of this appendix). Determine the locations where the factors of the checklist describe common areas. Specifically note common areas of material condition, material friability, and population. These areas are assessment cells. Mark the floor plans with the cell boundaries. (Note: An assessment cell's boundaries may be determined by ACM condition, building architecture, population distribution, or type of ACM. An assessment cell may be as small as a room or as large as an entire floor. Refer to the examples in Appendix C.) Collect representative bulk samples from damaged pipe, boiler, or duct insulated area. Collect at least three bulk samples from each homogeneous (same color and texture) sprayed-on or trowelled-on area. There may be more than one assessment cell within a homogeneous area. Therefore, there is no requirement to collect three bulk samples per cell. If the core sample hole increases the friability of the material being sampled, repair it with a bridging or penetrating encapsulant, spray adhesive, latex paint, or cover with tape. Mark the location of the bulk samples with labels. The labels must have unique sample numbers, the date collected, the sampler's name, and state "CAUTION - Possible Asbestos - Do Not Remove or Deface". The adhesive backing on the label must be strong enough so it may not be easily removed. See Section 2 of this appendix for bulk sampling guidance. Also mark the floor plan(s) with the same information. For those bulk sample results which are positive for asbestos, mark those locations on the floor plans and the bulk sample location labels with a large "red A". Perform the Asbestos GRADE rating and assessment based on the ACM present. Complete the GRADE checklist for each assessment cell. Be sure to include the bulk sample numbers and identify the assessment cell with a unique number which must be marked on each page (Form No.) of the checklist and the floor plan. Note: To save time, the GRADE checklist can be partially completed before the bulk sample results are obtained. Just add the results to finish the GRADEing.

4. If there are no friable materials, there are two options. Option 1 is to discontinue the cell assessment (i.e., no further action). Option 2 asks if there are any nonfriable materials suspected of containing asbestos. See Table B-1 of this section for a list of suspected ACMs. If no, document your conclusions on the floor plans. If yes to option 2, go to paragraph 5.

5. If you decide to continue the assessment and suspect there are asbestos-containing materials (paragraph 4) or if you answer no to the question of whether the friable material is sprayed-on, trowelled-on, or damaged (paragraph 3), there are two options:

Option 1: Assume the suspect material(s) contain asbestos and establish a special Operation and Maintenance (O&M) Program to control potential asbestos hazards (refer to Chapter 3 of the EPA's "Purple Book" for special O&M guidance).

Option 2: Collect bulk samples from the suspected materials. The EPA does not provide guidance for collecting bulk samples from intact pipe, boiler, and duct insulation. The number of bulk samples collected may be determined by population at risk, building renovation or demolition plans, the emotional and political climate, or funding.

**\*\*SURVEY PROCEDURE\*\***

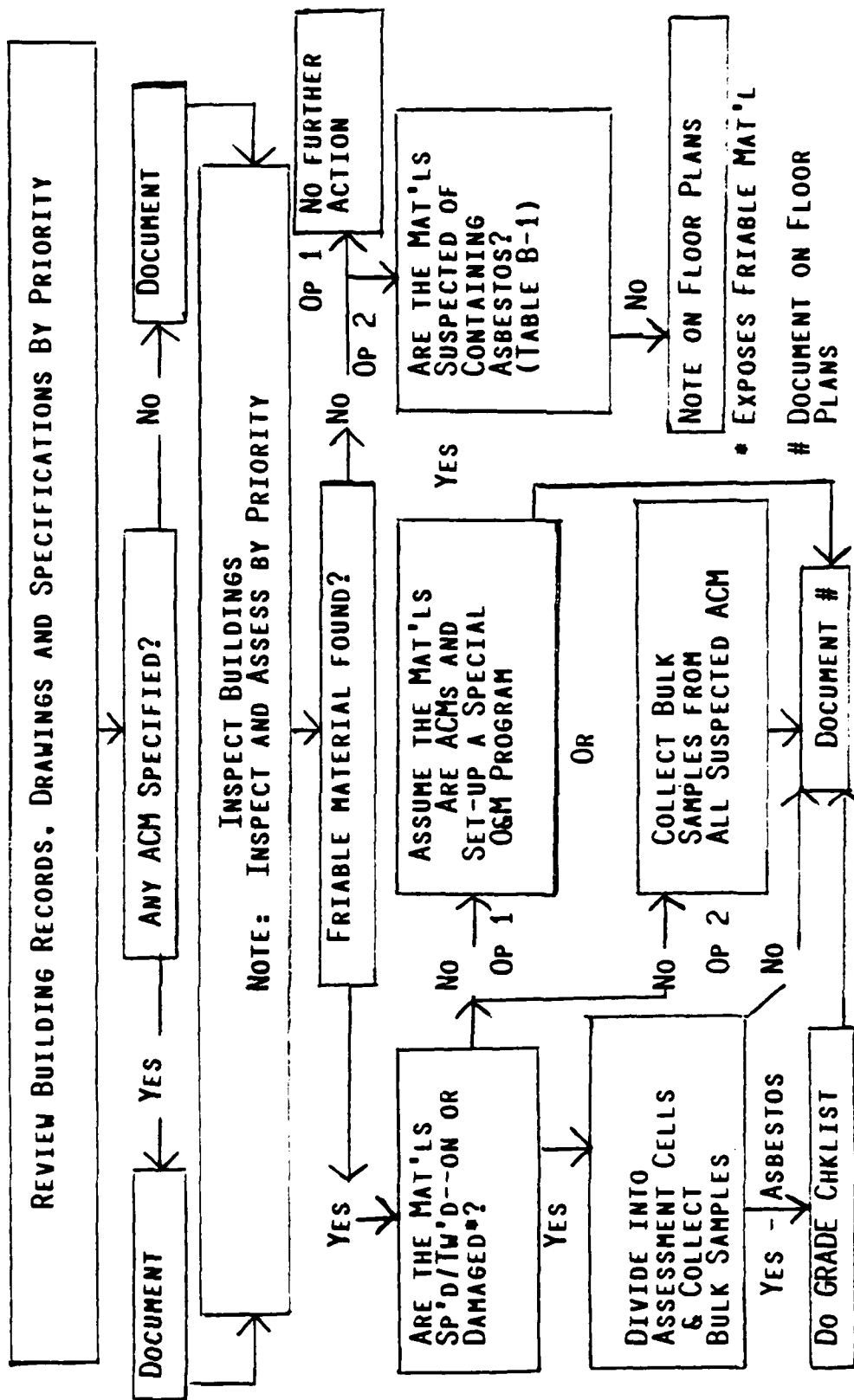

FIGURE B-1. SURVEY PROCEDURE

Table B-1: Asbestos-Containing Materials Found in Buildings\*

Subdivision	Generic name	Asbestos(\$)	Dates of use	Binder/sizing
Surfacing material	sprayed- or troweled-on	1-95	1935-1970	sodium silicate, portland cement, organic binders.
Preformed thermal insulating products	batts, blocks, and pipe covering 85% magnesia calcium silicate	15 6-8	1926-1949 1949-1971	magnesium carbonate calcium silicate
Textiles	cloth <sup>a</sup> blankets (fire) <sup>a</sup> felts: blue stripe red stripe green stripe sheets: cord/rope/yarn <sup>a</sup> tubing tape/strip curtains <sup>a</sup> (theatre, welding)	100 90-95 80 90 95 50-95 80-100 80-85 90 60-65	1910-present 1920-present 1920-present 1920-present 1920-present 1920-present 1920-present 1920-present 1945-present	none cotton/wool cotton cotton cotton cotton/wool cotton/wool cotton/wool cotton/wool
Cementitious concrete-like products	extrusion panels: corrugated flat flexible flexible perforated laminated (outer surface) roof tiles clapboard and shingles: clapboard siding shingles roofing shingles pipe	8 20-45 40-50 30-50 30-50 35-50 20-30 12-15 12-18 20-32 20-15	1965-1977 1930-present 1930-present 1930-present 1930-present 1930-present 1930-present 1944-1945 unknown-present unknown-present 1935-present	portland cement portland cement portland cement portland cement portland cement portland cement portland cement portland cement portland cement portland cement
Paper products	corrugated: high temperature moderate temperature indented millboard	90 35-70 98 80-85	1935-present 1910-present 1935-present 1925-present	sodium silicate starch cotton and organic-binder starch, lime, clay
Roofing felts	smooth surface mineral surface shingles pipeline	10-15 10-15 1 10	1910-present 1910-present 1971-1974 1920-present	asphalt asphalt asphalt asphalt
Asbestos-containing compounds	caulking putties adhesive (cold applied) joint compound roofing asphalt mastics asphalt tile cement roof putty plaster/stucco speckles  sealants fire/water  cement, insulation cement, finishing cement, magnesia	30 5-25  5 5-25 13-25 10-25 2-10 3-5  50-55  20-100 55 15 50	1930-present 1945-present 1945-1975 unknown-present 1920-present 1959-present unknown-present unknown-present 1930-1975  1935-present  1900-1973 1920-1973 1926-1950 1930-present	linseed oil asphalt asphalt asphalt asphalt asphalt asphalt portland cement starch, casein, synthetic resins castor oil or polyisobutylene clay clay magnesium carbonate portland cement
Asbestos ebony products				
Flooring tile and Sheet Goods	vinyl/asbestos tile asphalt/asbestos tile sheet goods/resilient	21 26-33 30	1950-present 1920-present 1950-present	poly(vinyl)chloride asphalt dry oils
Wallcovering	vinyl wallpaper	6-8	unknown-present	--
Paints and coatings	roof coating air tight	4-7 15	1900-present 1940-present	asphalt asphalt

\* The information in this Appendix is taken, with modification, from: Lory EE, Coin D.C. February 1981. Management Procedure for Assessment of Friable Asbestos Insulating Material, Port Hueneue, CA: Civil Engineering Laboratory Naval Construction Battalion Center. The U. S. Navy prohibits the use of asbestos-containing materials when acceptable nonasbestos substitutes have been identified.

<sup>a</sup> Laboratory aprons, glove, cord, rope, fire blankets, and curtains may be common in schools.

APPENDIX B

Section 2

Bulk Sampling Recommendations

## BULK SAMPLING PROCEDURES

### Asbestos-Containing Materials (ACM)

#### 1. Suspected ACM Sampling

a. Purposefully identify areas and materials to be sampled based on building specifications and visual observations.

- (1) Friable material (able to crumble with hand pressure).
- (2) Exposed and deteriorating nonfriable material.
- (3) Damaged and exposed pipe and boiler insulation.

b. EPA recommends collecting three bulk samples from each homogeneous area. "A homogeneous area contains friable material that seems by texture and color to be uniform." Sample collection should be evenly distributed throughout the area or chosen at random (see reference b)

#### 2. How to sample

a. Be careful

b. Use a containment device: Since the material should not be sent wet, use a containment device such as a plastic bag around the sampler.

c. Avoid inhaling any fibers regardless of the anticipated concentration. Minimum protection is afforded by a cartridge type respirator with high efficiency filters.

d. Obtain a core sample: This is a complete cross-sectional sample of the material from the surface it is covering to its outer layer. Forceps, a coring device, or even one's fingers can be used to collect the sample (disposable gloves must be worn if using your fingers). Twenty cubic centimeters of the material will be enough for analysis. Clean the sampler and the gloves with a damp paper towel after each use.

e. Place the material in a clear glass container: With a single use sampler, only wet-wipe the exterior before capping. With a reusable coring device, eject the sample into the glass container and wet-wipe the device.

f. Label the sample and the sample location: Clearly identify the sample with location, date collected, etc. Mark the location with tape and note the sample number and date. Also, identify the location on the building floor plan.

g. Clean debris: Use a wet towel or a high efficiency particulate absolute (HEPA) vacuum cleaner to cleanup debris. Discard as asbestos waste.

3. Repair the damage caused by sampling: Latex paint or spray adhesive may be used to repair small (20 cc sample) damaged areas. Tape also works well.



Recommended publications:

a. Guidance for Controlling Asbestos-Containing Materials in Buildings, EPA 560/5-85-024, June 1985. ("Purple Book")

b. Asbestos-Containing Materials in School Buildings - Guidance for Asbestos Analytical Programs. EPA 560/13-80-017A, December 1980. (This document applies a statistical approach to bulk sampling)

c. EPA Office of Pesticides and Toxic Substances hotline: 800-424-9065. (Source of EPA publications on Asbestos)

## ASBESTOS BULK SAMPLING KIT

1. Wide mouth, clear, glass sampling containers.
2. Tweezers or wooden tongue depressors for taking sample.
3. Labels for marking and identifying the samples.
4. Paper towels for wiping the sample containers.
5. Tape for sealing the sample container.
6. Disposable plastic gloves for hand protection. Surgeon's gloves are okay.
7. Plastic bags for disposal of excess debris and used protective equipment.
8. Protective eyewear for overhead sampling.
9. Disposable coveralls, as necessary.
10. Disposable drop cloth, as necessary.
11. Respiratory protection.
12. A judgment has to be made by the individual taking the sample(s) on the type and amount of protection required. The process of taking bulk samples can arouse a great deal of interest. Be discrete. Taking samples after duty hours may be the best approach, especially if it requires donning of full protective equipment.

## SAMPLING FOR BULK ASBESTOS

### SAMPLING

Use a clear 2 oz wide mouth glass jar. Collect a representative sample of the material to be analyzed and place it in the jar. Screen out gross particles, (i.e., extremely large pieces, unless the material is of block type) collect approximately 20 cc of sample. If this poses any problems, contact the Laboratory (Mr Ken Roberson, AV 240-3626) for information before proceeding with the sampling. Label the sample jar with a label and tape the cap down so that it does not come loose during shipment to the laboratory.

### SHIPPING

Enclose the sample jars in a plastic bag and then place the bag in a box with sufficient packing material so that the jars do not break in transit. Include the appropriate sampling forms with the samples. If the analysis is required on a priority basis, contact the Laboratory (AV 240-3626) to report the problem and the number of samples to expect. On all priority analysis requests, include a letter requesting priority analysis, the reason for the priority, and the name of the person contacted about the request. Please mark the sample forms "PRIORITY" in red.

Below is a list of sources and catalog numbers for suitable jars:

Fisher Scientific  
50 FADEM Road  
Springfield ND 07081

Straight-Sided Round Bottles  
Catalog No. 03-320-3B  
Cap 2 oz price: \$27.00 per case of 24

VWR Scientific  
P.O. Box 7900  
San Francisco CA 94120

Squat Form Bottles  
Catalog No. 16195-044  
Cap 2 oz price: \$26.52 per case

Wheaton Scientific  
1000 North Tenth Street  
Millville NJ 08332

Wide Mouth Bottle  
Catalog No. 221174  
Cap 60 mL Price: \$42.33 per case of 48

American Scientific Products  
Division of American Hospital  
Supply Corp.  
McGaw Park IL 60085  
1-312-689-8140

Wide Mouth Bottles  
Catalog No. B7454-4

APPENDIX B

Section 3

Asbestos GRADE Checklist

AIR FORCE ASBESTOS GRADE CHECKLIST for SPRAYED-ON TROWELLED-ON, or DAMAGED FRIABLE MATERIAL

BASE: \_\_\_\_\_ BLDG/RM NOS. \_\_\_\_\_ FACILITY/OFFICE: \_\_\_\_\_ INSPECTOR (DATE) \_\_\_\_\_

\*\*\*\*\* Part I: DAMAGE/RISK \*\*\*\*\*

- Physical Damage, Visible evidence: \_\_\_(5) High; \_\_\_(4) Moderate; \_\_\_(2) Low; \_\_\_(1) Minimal; \_\_\_(0) None
- Water Damage: \_\_\_(3) Yes; \_\_\_(0) No
- Proximity to Items for Repair. If both a. and b. apply, score the one with the highest rating. (Max 3 pts). How far? :  
 "a". Sprayed or Trowelled-on: \_\_\_(3) <1 ft or ceiling panel contam.; \_\_\_(2) 1<7<5 ft; \_\_\_(1) >5 ft; \_\_\_(0) >5 ft No rout. maint.
- "b". Pipe, Boiler, or Duct Insulation, Damage by routine maint. ? : \_\_\_(3) ceiling panel contam.; \_\_\_(1) Yes; \_\_\_(0) No
- Type of Mat'l: \_\_\_(0-4) Other friable mat'l; \_\_\_(1) Boiler and/or pipe; \_\_\_(3) HVAC; \_\_\_(4) Ceilings or walls
- Potential for Contact: "<10 ft" \_\_\_(8) High; \_\_\_(5) Medium; \_\_\_(2) Low; \_\_\_(1) High; \_\_\_(3) Medium; \_\_\_(0) Low
- Asbestos Content, % with highest prob: \_\_\_(1) 1%<30; \_\_\_(3) 30%<50; \_\_\_(5) >50%; NO HAZARD all samples no asbestos

Damage (D) Total \_\_\_\_\_

\*\*\*\*\* Part II: EXPOSURE \*\*\*\*\*

- Friable: \_\_\_(6) High; \_\_\_(3) Moderate; \_\_\_(1) Low
- Area of Visible Mat'l: \_\_\_(0) <10 ft<sup>2</sup>; \_\_\_(1) 10<ft<sup>2</sup><100; \_\_\_(2) 100<ft<sup>2</sup><1000; \_\_\_(3) >1000 ft<sup>2</sup>
- Walls: \_\_\_(4) Rough; \_\_\_(3) Pitted; \_\_\_(2) Moderate; \_\_\_(1) Smooth
- Ventilation (max 7 pts): \_\_\_(5) Interior supply; \_\_\_(2) Interior return; \_\_\_(1) Air supply-fiber potential; \_\_\_(0) None
- Air Movement Affecting Mat'l: \_\_\_(5) Routine turbulent or abrupt air mvmt; \_\_\_(2) Exposed to percept air; \_\_\_(0) No percept air
- Activity: \_\_\_(5) High-constant vibs; \_\_\_(2) Medium-occasional vibs; \_\_\_(0) Low-admin office, classroom, waiting room, etc.
- Floor: \_\_\_(4) Carpet; \_\_\_(2) Seamed or rough surface; \_\_\_(1) Smooth continuous surface; \_\_\_(0-4) Unique situations
- Barriers. If both a. and b. apply, score the one with the highest rating. Check all that apply (Max of 4 pts):  
 "a". Sprayed or trowelled-on on ceiling or walls: \_\_\_(1) Suspend ceiling; \_\_\_(2) Encapsulation; \_\_\_(3) Railing or wire; \_\_\_(4) None
- "b". Pipe, Boiler, Duct, or Other Mat'l: \_\_\_(1) >25%; \_\_\_(2) 25%<50; \_\_\_(3) 50%<75; \_\_\_(4) 75%<100
- Population: \_\_\_(1) <9 or for corridors; \_\_\_(2) 10<Pop<200; \_\_\_(3) 201<Pop<500; \_\_\_(4) 501<Pop<1000; \_\_\_(5) >1001 or med or youth

Exposure (E) Total \_\_\_\_\_

Rating: R = 12.0324 - 0.1683 + D - 0.1693 + L

Sample Numbers (Air & Bulk): \_\_\_\_\_

AIR FORCE  
ASBESTOS GRADE CHECKLIST  
for  
SPRAYED-ON, TROWELLED-ON, or DAMAGED FRIABLE MATERIAL

Form # \_\_\_\_\_

Base: \_\_\_\_\_ Bldg/Rm Nos.: \_\_\_\_\_  
Facility/Office: \_\_\_\_\_ Inspector (date): \_\_\_\_\_  
Sample Numbers (Air and Bulk): \_\_\_\_\_

PART I: DAMAGE or RISK

>Physical. Assess damage based on visible evidence of work surface accumulation or the condition of the sprayed-on or trowelled-on surface materials.

- (5) High > Dislodged pieces are evident on work surfaces.
- (4) Moderate > There is evidence of visible material fallout.
- (2) Low > There is some evidence of material fallout.
- (1) Minimal > There are isolated and very small areas of material damage or fallout.
- (0) None > No damage or evidence of any material fallout.

>Water

- (3) Yes > Visible water damage.
- (0) No > No water damage.

>Proximity to items for repair. If both A and B apply, score the one with the highest rating. (Check all that apply. Maximum of 3 points.) How far is the material from routine maintenance areas?

A. Sprayed-on or Trowelled-on: Could the material be damaged by routine maintenance?

- (3) < 1 ft or a ceiling panel contaminated with ACM must be removed.
- (2)  $1 \leq ? < 5$  ft
- (1)  $\geq 5$  ft
- (0)  $\geq 5$  ft and no routine maintenance.

B. Pipe, Boiler, or Duct Insulation: Could damage occur as a result of routine maintenance.

- (3) A ceiling panel contaminated with ACM must be removed.
- (1) Yes
- (0) No

PREVIOUS PAGE  
IS BLANK



>Type of Material. If area or room contains numerous categories of material, score the friable material with the largest area. Check all other categories that are found.

- (0-4) Other material, i.e., wallboard, ceiling tile, or floor tile with exposed friable ends, abrasions, etc.
- (1) Boiler and/or pipe
- (3) HVAC > Suspected ACM on exterior of ducts
- (4) Ceilings or Walls

>Potential for Contact by Occupants. How far is the friable sprayed-on, trowelled-on, or damaged material from the heads of the room or area occupants? Regardless of whether there is a barrier. High, medium, and low refer to the chance of the room or area personnel actually disturbing the ACM.

- |                                     |                                     |
|-------------------------------------|-------------------------------------|
| <u>&lt;</u> 10 ft                   | <u>&gt;</u> 10 ft                   |
| <input type="checkbox"/> (8) High   | <input type="checkbox"/> (5) High   |
| <input type="checkbox"/> (5) Medium | <input type="checkbox"/> (3) Medium |
| <input type="checkbox"/> (2) Low    | <input type="checkbox"/> (0) Low    |

>Asbestos Content. Use the percentage for the material that has the highest probability of becoming airborne.

- (1)  $1 < \% < 30$
- (3)  $30 < \% < 50$
- (5)  $> 50 \%$
- All bulk samples from the friable surface or damaged material(s) indicate asbestos. If so, NO HAZARD.

Bulk sample results

Sample No.	Type Asbestos	%	Source
------------	---------------	---	--------

DAMAGE (D) TOTAL \_\_\_\_\_ (Max 28, Min 1)      Evaluator (date) \_\_\_\_\_

AIR FORCE  
ASBESTOS GRADE CHECKLIST  
for  
SPRAYED-ON, TROWELLED-ON, or DAMAGED FRIABLE MATERIALS

PART II: EXPOSURE

>Friable. Defined by EPA: "hand pressure can crumble, pulverize, or reduce to powder when dry". Score the friability of the surface or damaged material.

- \_\_\_ (6) High > Material is fluffy and/or the slightest hand pressure can dislodge it. A slight breeze may disperse the material.
- \_\_\_ (3) Moderate > Material can be dislodged or scraped or crumbled by hand.
- \_\_\_ (1) Low > Material is firmly bound, difficult to scrape off by hand.

>Area of visible surface or damaged friable material.

- \_\_\_ (0) < 10 ft<sup>2</sup>                      These small areas should be repaired ASAP.
- \_\_\_ (1) 10 ≤ ft<sup>2</sup> < 100
- \_\_\_ (2) 100 ≤ ft<sup>2</sup> < 1000
- \_\_\_ (3) > 1000 ft<sup>2</sup>

>Walls. Refers to the ability of the walls to hold fibers for reentrainment. If more than one type, score the roughest. If the wall material is exposed friable asbestos, score as rough.

- \_\_\_ (4) Rough. Difficult to clean with a HEPA vacuum.
- \_\_\_ (3) Pitted. Difficult to clean with a damp cloth but cleanable with a HEPA vacuum.
- \_\_\_ (2) Moderate. Can be cleaned with a damp cloth.
- \_\_\_ (1) Smooth. Easily cleaned with a damp cloth.

>Ventilation. Check all categories that apply. (Maximum 7 points)

- \_\_\_ (5) The interior of the supply duct or plenum is coated or littered with friable material or is within 5 feet of a supply diffuser or fan and the condition of the material may result in fibers being entrained into the airflow.
- \_\_\_ (2) The interior of the return air duct or plenum is coated or littered with friable material and is part of a recirculating system.
- \_\_\_ (1) Air being supplied to the room or cell is: (1) drawn from an area where the potential for asbestos fiber release is possible, or (2) part of a recirculating system where fibers may be drawn into the system.
- \_\_\_ (0) None of the above applies.



→Air Movement. This refers to the general air movement in the room or area that may affect the friable surface or damaged material.

- (5) Material is subjected to routine turbulent or abrupt air movement.
- (2) Material is exposed to perceptible or occasional air streams.
- (0) No perceptible air flow in the room or area.

→Activity. Refers to forces acting on the surface covered, i.e., vibrational, water or steam, etc.

- (5) High → Friable surface or damaged material is subject to constant vibration (mechanical rooms).
- (2) Medium → Occasional vibration. (a warehouse where forklifts are used, next to an active runway, kitchen)
- (0) Low → Administrative office, library, classroom, storage room, stairway or corridor, waiting room, etc.

→Floor.

- (4) Carpet or an extremely rough surface difficult to clean by HEPA vacuum or by a damp cloth.
- (2) Seamed or rough surface (e.g., uncoated concrete).
- (1) Smooth continuous surface (e.g., finished or coated concrete, smoothly joined tile, etc.).
- (0→4) Unique situations (wood or dirt floors with varying degrees of smoothness).

→Barriers. If both A and B apply, score the one with the highest rating. Check all that apply. (Maximum of 4 points)

A. Refers to sprayed-on or trowelled-on material on ceiling or walls.

- (1) Suspended ceiling or accessible secondary wall.
- (2) Encapsulation or covered with nonasbestos material.
- (3) Railing or chicken wire.
- (4) None

B. Pipe, Boiler, Duct, or Other surface or damaged materials. Percent of total exposed and visible to the occupants.

- (1) < 25%
- (2) 25 < % < 50
- (3) 50 < % < 75
- (4) 75 < % < 100

Population. This involves defining the average occupancy and outside visitor traffic (do not count visitors from within the building) of a room or area based on an 8 hour per day exposure. For example, a waiting area at Finance normally has 15 individuals assigned to the office. They see approximately 240 customers from outside the building over an 8 hour day. Each customer is serviced and gone within 30 minutes.

$$([240 \text{ persons} \times 0.5 \text{ hours}] / 8 \text{ hours}) + 15 \text{ occupants} = 30$$

.....Score as 2

- (1) < 9 or for corridors
- (2) 10 < Pop < 200
- (3) 201 < Pop < 500
- (4) 501 < Pop < 1000
- (5) > 1001 for medical facilities, youth centers, child care facilities or residential buildings irregardless of the population.

EXPOSURE (E) TOTAL \_\_\_\_\_ (Max 43, Min 5)      Evaluator (date) \_\_\_\_\_

$$R = 12.0324 \times 0.1683 * D \times 0.1693 * E$$

APPENDIX B

Section 4

Rating Interval versus Priority

Section 4

$$R = 12.0324 > (0.1683 * D) > (0.1693 * E)$$

where: R = Rating  $0.0401 \leq R \leq 11.0176$   
 D = Sum of D  $1 \leq D \leq 28$   
 E = Sum of E  $5 \leq E \leq 43$

Time, money, manpower, and the local political and emotional climate may determine the frequency and extent of the actions undertaken by the base. The below listed recommended actions only refer to exposed or damaged friable ACM.

Recommended Actions

AF Priority	Semiannual visual Inspection <sup>^</sup>	Air Sampling*			Re GRADE+ (Checklist: Sect 3 App B)	R Interval
		BG	1/2	1		
1	yes	yes	yes			
2	yes	yes	yes	1/2	$6 \leq R < 7$	
3	yes	BEE	BEE	BEE	$7 \leq R < 8$	
4	yes	BEE			$8 \leq R < 9$	
5	yes	BEE			$9 \leq R < 10$	
6	yes	BEE			$R \leq 10$	

- <sup>^</sup> The BEE should include inspections of all ACM as part of the annual facility surveys.
- \* BG = background, 1/2 = semiannual, 1 = annual  
The BEE makes a local decision whether to air sample.
- + Re>GRADE of a priority 1 assessment cell is not necessary unless it is needed to decide priority within the group or the cell has had the asbestos abated or disturbed. Re>GRADEing of priority 4>6 cells should be accomplished at the discretion of the BEE based on damage and/or exposure factor changes. Note: the action level for asbestos exposure is 0.1 fibers per cubic centimeter (f/cc) as an 8>hour time weighted average (TWA). Occupational physicals and routine air sampling do not have to be accomplished if the representative samples do not exceed 0.1 f/cc as an 8>hr TWA.

## APPENDIX C

### Evaluation Examples

Note: In all the succeeding examples, the results of the bulk samples are known. In all cases except those where historical data exists or where the building records specify asbestos type and percent, the building inspector will evaluate the assessment cells with sprayed-on, trowelled-on, or damaged friable material not knowing if asbestos is involved.

SUMMARY OF EXAMPLE EVALUATION RESULTS

Example #	R Value	Damage (D)	Exposure (E)	AF Priority
12	4.6032	20	24	1
15	5.6200	21	17	1
4	6.4585	13	20	2
7	6.6228	8	24	2
11	6.7991	15	16	2
10	6.9634	10	20	2
11	7.1297	7	22	3
6	7.8109	11	14	3
3	7.9772	8	16	3
8	8.4901	13	8	4
9	8.6514	5	15	4
5	8.6554	9	11	4
2	8.8207	5	14	4
13	9.3296	5	10	5
14	10.8523*	2	5	6

\* No damage to friable ACM. Rating not necessary. The "Exposure: Friable, Area, and Barriers" ratings were given a 1, 0, and 1, respectively, just to complete the rating exercise.

EXAMPLE No. 1, Mobility Processing Hangar

Assessment cell: an entire building

The structure is 200 feet (ft) long, 75 ft wide, with a gabled roof 30 ft high at the walls and 45 ft high at the peak. The walls, hangar doors, and the ceiling are all insulated with the same uniformly colored or textured, sprayed-on highly friable asbestos-containing material (ACM), 5-30% chrysotile. The insulation is held in place by chicken wire. To protect it from damage, a five foot high corrugated metal barrier was constructed along the base of the three walls. The floor of the hangar is a finished concrete. Inspection of the floor, desks, processing equipment, etc., did not reveal any ACM fallout; however, there was a layer of dust. Mobility exercises are conducted quarterly; approximately 400 people being processed in two days. It is estimated that each processee spends only 30 minutes actually in the hangar.

The facility is located adjacent to the runway. Takeoffs by C-5, C-141, and other large cargo and personnel carriers appear to shake the structure. Generally, the doors are left open during processing and in the summer pedestal fans supplement the outdoor breezes. Winter heating though not often required is provided by radiant fixtures. Therefore, there are no insulated pipes or boilers in the hangar. There is no water damage, no evidence of any damage to the insulation, and no routine maintenance history or requirements involving insulation contact or removal.

AIR FORCE ASBESTOS GRADE CHECKLIST for SPRAYED-ON TROWELLED-ON, or DAMAGED FRIABLE MATERIAL

BASE: ANYWHERE AFB BLDG/RM NOS. 1425 FACILITY/OFFICE: MAINTENANCE PROCESSING INSPECTOR (DATE) J. D. S. 1 AUG 86

\*\*\*\*\* Part I: DAMAGE/RISK \*\*\*\*\*

- Physical Damage, Visible evidence: (5) High; (4) Moderate; (2) Low; (1) Minimal; (U) None
- Water Damage: (3) Yes; (0) No
- Proximity to Items for Repair. If both a. and b. apply, score the one with the highest rating. (Max 3 pts). How far? :
  - "a". Sprayed or Trowelled-on: (3) <1 ft or ceiling panel contam.; (2) 1-7<5 ft; (1) >5 ft; (U) >5 ft No rout. maint.
  - "b". Pipe, Boiler, or Duct Insulation, Damage b, routine maint. ? : (3) ceiling panel contam.; (1) Yes; (0) No
- Type of Mat'l: (0-4) Other friable mat'l; (1) Boiler and/or pipe; (3) HVAC; (4) Ceilings or walls
- Potential for Contact: "<10 ft" (8) High; (5) Medium; (2) Low; ">10 ft" (5) High; (3) Medium; (0) Low
- Asbestos Content, % with highest prob: (1) 1-<30; (3) 30-<50; (5) >50%; NO HAZARD all samples no asbestos

Damage (D) Total 7

\*\*\*\*\* Part II: EXPOSURE \*\*\*\*\*

- Friable: (6) High; (3) Moderate; (1) Low
- Area of Visible Mat'l: (0) <10 ft<sup>2</sup>; (1) 10<ft<sup>2</sup><100; (2) 100<ft<sup>2</sup><1000; (3) >1000 ft<sup>2</sup> TOTAL 32,500 ft<sup>2</sup>
- Walls: (4) Rough; (3) Pitted; (2) Moderate; (1) Smooth
- Ventilation (max 7 pts): (5) Interior supply; (2) Interior return; (1) Air supply-Fiber potential; (U) None
- Air Movement Affecting Mat'l: (5) Routine turbulent or abrupt air mvmt; (2) Exposed to percept air; (U) No percept air
- Activity: (5) High-constant vibs; (2) Medium-occasional vibs; (0) Low-admin office, classroom, waiting room, etc. AK VIBS
- Floor: (4) Carpet; (2) Seamed or rough surface; (1) Smooth continuous surface; (0-4) Unique situations
- Barriers. If both a. and b. apply, score the one with the highest rating. Check all that apply (Max of 4 pts):
  - "a". Sprayed or trowelled-on on ceiling or walls: (1) Suspend ceiling; (2) Encapsulation; (3) Railing or wire; (4) None
  - "b". Pipe, Boiler, Duct, or Other Mat'l: (1) <25%; (2) 25-<50; (3) 50-<75; (4) 75-<100
- Population: (1) <9 or for corridors; (2) 10<Pop<200; (3) 201<Pop<500; (4) 501<Pop<1000; (5) >1001 or med or youth
- Exposure (E) Total 22 Rating: R = 12.0324 - 0.1683 \* D - 0.1693 \* E R = 7.1297

Sample Numbers (Air & Bulk): GM 86 0001-3 (AULK) SAMPLET 193- WALK - CHRYSOLE 15-107, 3 CEILING " 5-15%

POPULATION 400 per 1/2 hr ea / 16 hrs = 12.5 pers. per day  
AVG is 12.5 / 5 = 2.5 is 59



EXAMPLE No. 2, Clinic Hallway and Waiting Room

Assessment cell: a corridor on the basement floor

The area in question is the ground floor corridor of a clinic. This same corridor also serves as the waiting area for the laboratory and x-ray. Normal waiting time is 10 minutes for both sections and each sees on the average of 30 patients per day. The corridor is 100 ft long, eight ft wide, and eight and one-half ft high. There are no ventilation grills or duct openings through any of the painted concrete block walls. Eight insulated pipes run the entire length of the corridor and they are approximately seven and one-half ft above the carpeted floor. There is no evidence of any water damage to the insulation. The painted lagging material over the insulation is slightly damaged in three areas for a total of one-half a square foot of exposed, moderately friable ACM. The insulation contains 5-15% chrysotile. The lagging material is 85% chrysotile woven with cotton.

Note: The damage should be quickly repaired or encapsulated. After abatement, this area may be removed from the semiannual visual inspection scheme (see Section 4 Appendix B). Remember, the checklist only refers to sprayed-on, trowelled-on, or damaged friable ACM. The ACM should be checked during the BEE's annual walk-through. Future repair or renovation work in this area should be assessed for damage potential or ACM involvement.

IR FORCE ASBESTOS GRADE CHECKLIST FOR SPRAYED-ON TROWELLED ON, or DAMAGED FRIABLE MATERIAL

BASE: ANYWHERE AFB BLDG/WM NOS. 675 FACILITY/OFFICE: CLINIC COMPOUND INSPECTOR (DATE): I DUE / AUG 86

..... Part I: DAMAGE/RISK .....  
Physical Damage, Visible evidence: (5) High; (4) Moderate; (2) Low;  (1) Minimal; (0) None

Water Damage: (3) Yes;  (0) No

Proximity to Items for Repair. If both a. and b. apply, score the one with the highest rating. (Max 3 pts). How far? :

a. Sprayed or Trowelled-on: (3) <1 ft or ceiling panel contam.; (2) 1-7-5 ft; (1) >5 ft; (0) >5 ft No rout. maint.

b. Pipe, Boiler, or Duct Insulation, Damage by routine maint. ? : (3) ceiling panel contam.; (1) Yes;  (0) No

Type of Mat'l: (0-4) Other friable mat'l;  (1) Boiler and/or pipe; (3) HVAC; (4) Ceilings or walls

Potential for Contact: >10 ft (b) High; (2) Medium;  (2) Low; >10 ft (5) High; (3) Medium; (0) Low

Asbestos Content, % with highest prob:  (1) 1-50; (3) 30-50; (b) >50%; NO HAZARD all samples no asbestos

Damage (D) Total 5 ..... Part II: EXPOSURE .....

Friable: (6) High;  (3) Moderate; (1) Low

Area of Visible Mat'l:  (0) <10 ft<sup>2</sup>; (1) 10-100; (2) 100-1000; (3) >1000 ft<sup>2</sup> 1/2 ft<sup>2</sup>

Walls: (4) Rough; (3) Pitted; (2) Moderate;  (1) Smooth

Ventilation (max 7 pts): (5) Interior supply; (2) Interior return; (1) Air supply-Fiber potential;  (0) None

Air Movement Affecting Mat'l: (5) Routine turbulent or abrupt air mvmt; (2) Exposed to percept air;  (0) No percept air

Activity: (5) High-constant vibs; (2) Medium-occasional vibs;  (0) Low-admin office, classroom, waiting room, etc.

Floor:  (4) Carpet; (2) Seamed or rough surface; (1) Smooth continuous surface; (0-4) Unique situations

Barriers. If both a. and b. apply, score the one with the highest rating. Check all that apply (Max of 4 pts):

a. Sprayed or trowelled-on on ceiling or walls: (1) Suspend ceiling; (2) Encapsulation; (3) Railing or wire; (4) None

b. Pipe, Boiler, Duct, or Other Mat'l:  (1) >25%; (2) 25-50; (3) 50-75; (4) 75-100

Population: (1) <9 or for corridors; (2) 10-200; (3) 201-500; (4) 501-1000;  (5) >1001 or med or youth

Exposure (E) Total 14 Rating: R - 12.0324 - 0.1683 \* D - 0.1693 \* L R = 8.8207

Sample Numbers (Air & Bulk): GM 86004-7 (BUCK) SAMPLE 4 CHRYSTLE 5-15 PIPE

7X2 LAGGING  
6x7 " 5-15 PIPE

REPAIR SMALL AREA DAMAGE

### EXAMPLE No. 3, Boiler and Heating Plant

Assessment cell: an entire building. The office is considered within the cell.

This 30 year old boiler and heating plant has five boilers, two surge tanks, two de-aerators, and hundreds of feet of insulated, lagged pipes. The structure is 200 ft long, 60 ft wide, and 40 ft high. Most of the insulation is in good shape; however, there are spots where the insulation is exposed such as manhole entries, places where workers have stood on the pipes, and where the ACM mud has deteriorated around valves due to age. In all, 18 exposed or damaged areas were found which makeup an area of approximately 20 square feet. Eighteen bulk samples were taken from these highly friable areas and the results indicated the insulation and mud are 5-75% chrysotile asbestos.

The plant is monitored by three shifts of three men each. Each shift is eight hours. Most of the men's time is spent in the enclosed, air-conditioned office. But, they periodically walk the floor to inspect the equipment and check the gages.

The floor is finished concrete and the ceiling and walls are fiberglass insulated. The backing on the fiberglass insulation is smooth and appears to be plastic. Less than 1% of the backing is damaged.

Lastly, the plant is usually very warm even in the middle of the winter. Therefore, all the doors are kept open to let the air move through the building and keep the temperatures bearable.

AIR FORCE ASBESTOS GRADE CHECKLIST FOR SPRAYED-ON TROWELLED-ON, OR DAMAGED FRIABLE MATERIAL

BASE: ANYWHERE AFB BLDG/RM NOS. 376 FACILITY/OFFICE: BULKER OPERATING INSPECTOR (DATE): J. DOE / AUG 86

\*\*\*\*\* Part I: DAMAGE/RISK \*\*\*\*\*

• Physical Damage, Visible evidence:  (5) High;  (4) Moderate;  (2) Low;  (1) Minimal;  (0) None  
• Water Damage:  (3) Yes;  (0) No

• Proximity to Items for Repair. If both a. and b. apply, score the one with the highest rating. (Max 3 pts). How far? :

"a". Sprayed or Trowelled-on:  (3) <1 ft or ceiling panel contam.;  (2) 1-7-5 ft;  (1) >5 ft;  (0) >5 ft No rout. maint.

"b". Pipe, Boiler, or Duct Insulation, Damage by routine maint. ? :  (3) ceiling panel contam.;  (1) Yes;  (0) No

• Type of Mat'l:  (0-4) Other friable mat'l;  (1) Boiler and/or pipe;  (3) HVAC;  (4) Ceilings or walls

• Potential for Contact: "<10 ft"  (8) High;  (5) Medium;  (2) Low; ">10 ft"  (5) High;  (3) Medium;  (0) Low

• Asbestos Content, % with highest prob:  (1) 1-%-30;  (3) 30-%-50;  (5) >50%; NO HAZARD all samples no asbestos

Damage (D) Total 8

\*\*\*\*\* Part II: EXPOSURE \*\*\*\*\*

• Friable:  (6) High;  (3) Moderate;  (1) Low

• Area of Visible Mat'l:  (0) <10 ft<sup>2</sup>;  (1) 10-ft<sup>2</sup>-100;  (2) 100-ft<sup>2</sup><1000;  (3) >1000 ft<sup>2</sup> 20 ft<sup>2</sup>

• Walls:  (4) Rough;  (3) Pitted;  (2) Moderate;  (1) Smooth

• Ventilation (max 7 pts):  (5) Interior supply;  (2) Interior return;  (1) Air supply-fiber potential;  (0) None

• Air Movement Affecting Mat'l:  (5) Routine turbulent or abrupt air mvmt;  (2) Exposed to percept air;  (0) No percept air

• Activity:  (5) High-constant vibs;  (2) Medium-occasional vibs;  (0) Low-admin office, classroom, waiting room, etc.

• Floor:  (4) Carpet;  (2) Seamed or rough surface;  (1) Smooth continuous surface;  (0-4) Unique situations

• Barriers. If both a. and b. apply, score the one with the highest rating. Check all that apply (Max of 4 pts):

"a". Sprayed or trowelled-on on ceiling or walls:  (1) Suspend ceiling;  (2) Encapsulation;  (3) Railing or wire;  (4) None

"b". Pipe, Boiler, Duct, or Other Mat'l:  (1) <25%;  (2) 25-%-50;  (3) 50-%-75;  (4) 75-%-100

• Population:  (1) <9 or for corridors;  (2) 10-Pop-200;  (3) 201-Pop-500;  (4) 501-Pop-1000;  (5) >1001 or med or youth

Exposure (E) Total 16 Rating: R = 12.0324 - 0.1683 \* D = 0.1693 \* L R = 7.9772

Sample Numbers (Air & Bulk): GM 860008-25 BULK. SAMPLED 8-12 CHRYSOLE 5-10, BULKERY 15

QC 860026 (SPLIT OF #20)

Pop: 3 MEN x 8 Hrs x 35 MFPS / 8 Hrs = 9

13-14 " SURFACE TWS 10L  
15-16 " " DE-ASBESTOS 10L  
17-20 " " PIPE  
21-25 " " 50-75 VALVE CEMENT

OPEN DOORS, HEAT, VIB. AIR

TIME MAINT SPENT IN CENTRAL AFB

5-5% MENEFF PHOS.

EXAMPLE No. 4, Foundry

Assessment cell: the main floor and the storage area. See Example 5 for the assessment of the offices.

This gabled structure is 150 ft long, 100 ft wide, has 15 foot high walls and a peak height of 30 feet. The entire ceiling area has sprayed-on asbestos insulation. Three bulk samples taken from the homogeneous material indicate the asbestos is 50-75% chrysotile and is considered moderately friable. The ACM was painted white five years ago but the coating is beginning to peel and flake. The only area where the workers can contact the ACM is the elevated storage area. Storage was constructed on a platform within the main structure along one quarter of the east facing long wall. The ACM is only six feet above the storage floor. Supplies are retrieved from storage about 10 times per day.

The walls of the foundry are corrugated sheetmetal and the floors are unfinished concrete. The storage area floor is a metal grate.

Overall the insulation is in excellent shape with no water damage. However, there is physical damage to the ACM in the storage area where there is evidence of material damage and fallout. Small pieces of insulation can be seen on the tops of boxes in the storage area and below the storage platform.

Since foundry work is hot work, the doors are usually left open. The 20 men working in the facility may move throughout the facility to accomplish their tasks. Some castings are very large and require a forklift to move.

All the building floor space is not used for foundry work. There are offices at one end. Foundry floor space takes up approximately 13,000 ft<sup>2</sup> and the offices the rest. See Example 5 for the office evaluation.

AIR FORCE ASBESTOS GRADE CHECKLIST FOR SPRAYED-ON TROWELLED-ON, or DAMAGED FRIABLE MATERIAL

BASE: ~~ANF-HZ-26~~ AFB BLDG/RM NOS. 1000 FACILITY/OFFICE: ~~Foundry~~ ~~AMEA~~ ~~AMEA~~ INSPECTOR (DATE) J. DOW 1 AUG 86

\*\*\*\*\* Part I: DAMAGE/RISK \*\*\*\*\*

- Physical Damage, Visible evidence: (5) High; (4) Moderate; (2) Low;  (1) Minimal; (U) None
- Water Damage: (3) Yes;  (0) No
- Proximity to Items for Repair. If both a. and b. apply, score the one with the highest rating. (Max 3 pts). How far? :  
 -a. Sprayed or Trowelled-on: (3) <1 ft or ceiling panel contam.; (2) 1-7<5 ft; (1) >5 ft;  (0) >5 ft No rout. maint.
- b. Pipe, Boiler, or Duct Insulation, Damage by routine maint. 7 : (3) ceiling panel contam.; (1) Yes; (0) No
- Type of Mat'l: (0-4) Other friable mat'l; (1) Boiler and/or pipe; (3) HVAC;  (4) Ceilings or walls
- Potential for Contact: <10 ft" (8) High; (5) Medium; (2) Low; >10 ft" (5) High;  (3) Medium; (0) Low
- Asbestos Content, % with highest prob: (1) 1%<30; (3) 30%<50;  (5) >50% NO HAZARD all samples no asbestos

Damage (D) Total 13 \*\*\*\*\* Part II: EXPOSURE \*\*\*\*\*

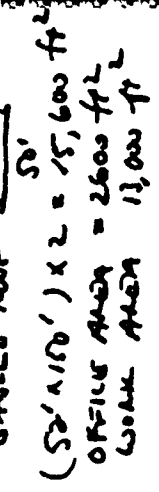

- Friable: (6) High;  (3) Moderate; (1) Low
- Area of Visible Mat'l: (0) <10 ft2; (1) 10-12<100; (2) 100-12<1000;  (3) >1000 ft2
- Walls: (4) Rough; (3) Pitted;  (2) Moderate; (1) Smooth
- Ventilation (max 7 pts): (5) Interior supply; (2) Interior return; (1) Air supply fiber potential;  (0) None
- Air Movement Affecting Mat'l: (5) Routine turbulent or abrupt air movmt;  (2) Exposed to percept air; (0) No percept air
- Activity: (5) High-constant vibs;  (2) Medium-occasional vibs; (0) Low-admin office, classroom, waiting room, etc.
- Floor: (4) Carpet;  (2) Seamed or rough surface; (1) Smooth continuous surface; (0-4) Unique situations
- Barriers. If both a. and b. apply, score the one with the highest rating. Check all that apply (Max of 4 pts):  
 -a. Sprayed or trowelled-on on ceiling or walls: (1) Suspend ceiling; (2) Encapsulation; (3) Railing or wires;  (4) None
- b. Pipe, Boiler, Duct, or Other Mat'l: (1) <25%; (2) 25%<50; (3) 50%<75; (4) 75%<100
- Population: (1) <9 or for corridors;  (2) 10<Pop<200; (3) 201<Pop<500; (4) 501<Pop<1000; (5) >1001 or med or youth
- Exposure (E) Total 20 Rating: R = 12.0324 - 0.1683 \* D - 0.1693 \* E R = 6.4585

Sample Numbers (Air & Bulk): 6A 860927-29 (AULK) AN CHRYSTLE 50-7526 CELENH

EXAMPLE No. 5, Foundry Offices

Assessment cell: the offices. This is one of two assessment cells for the entire building.

See Example 4 for the description of the building. These offices were built at the north end within the main structure. The offices cover approximately 2600 ft<sup>2</sup>. The interior ceiling height is only eight feet. The offices have wall to wall carpeting with painted sheetrock walls and a suspended ceiling made up of 2 ft X 4 ft panels. There is no evidence of any material fallout on top of the ceiling panels. Window air conditioning units provide cooling. Forced air heating from an electric furnace is ducted above the sheetrock ceiling through grills into each office. Air is supplied to the furnace from the interior of the foundry building. The warm air ducts are insulated with fiberglass. There are no ACMs in the offices. The only ACM to consider is the insulation on the ceiling above the office structure. Lastly, five personnel work in the offices full time.

AIR FORCE ASBESTOS GRADE CHECKLIST FOR SPRAYED-ON TROWELLED-ON, or DAMAGED FRIABLE MATERIAL

BASE: AYWHTS AB BLDG/RM NOS. 1090 FACILITY/OFFICE: Boundary Office INSPECTOR (DATE) J. DOE 1 AUG 86

..... Part I: DAMAGE/RISK .....

- Physical Damage, Visible evidence: (5) High; (4) Moderate; (2) Low; (1) Minimal;  (U) None
- Water Damage: (3) Yes;  (0) No
- Proximity to Items for Repair. If both a. and b. apply, score the one with the highest rating. (Max 3 pts). How far? : NO ACUM ON CEILING OR CORRIDORS
- "a". Sprayed or Trowelled-on: (3) <1 ft or ceiling panel contam.; (2) 1-7 <5 ft; (1) ≥5 ft;  (U) ≥5 ft No rout. maint. MAINT.
- "b". Pipe, Boiler, or Duct Insulation. Damage by routine maint. ? : (3) ceiling panel contam.; (1) Yes; (0) No
- Type of Mat'l: (0-4) Other friable mat'l; (1) Boiler and/or pipe; (3) HVAC;  (4) Cellings or walls
- Potential for Contact: "<10 ft" (8) High; (5) Medium; (2) Low; "≥10 ft" (5) High; (3) Medium;  (0) Low
- Asbestos Content, % with highest prob: (1) 1% <30; (3) 30% <50;  (5) >50% NO HAZARD all samples no asbestos

9 NO-789, on Boundary ceiling - emys/soflee

..... Part II: EXPOSURE .....

- Friable: (6) High;  (3) Moderate; (1) Low
- Area of Visible Mat'l:  (0) <10 ft<sup>2</sup>; (1) 10-100 ft<sup>2</sup>; (2) 100-1000 ft<sup>2</sup>; (3) ≥1000 ft<sup>2</sup>
- Walls: (4) Rough; (3) Pitted; (2) Moderate;  (1) Smooth
- Ventilation (max 7 pts): (5) Interior supply; (2) Interior return;  (1) All supply-fiber potential; (0) None
- Air Movement Affecting Mat'l: (5) Routine turbulent or abrupt air movt.; (2) Exposed to percept air;  (0) No percept air
- Activity: (5) High-constant vibs; (2) Medium occasional vibs;  (0) Low admin office, classroom, waiting room, etc.
- Floor:  (4) Carpet; (2) Seamed or rough surface; (1) Smooth continuous surface; (0-4) Unique situations
- Barriers. If both a. and b. apply, score the one with the highest rating. Check all that apply (Max of 4 pts):
- "a". Sprayed or trowelled-on on ceiling or walls:  (1) Suspend ceiling; (2) Encapsulation; (3) Rattling or wire; (4) None
- "b". Pipe, Boiler, Duct, or Other Mat'l: (1) ≥25%; (2) 25% <50; (3) 50% <75; (4) 75% <100
- Population:  (1) ≥9 or for corridors; (2) 10% Pop >200; (3) 20% Pop >500; (4) 50% Pop >1000; (5) ≥1001 or med or youth

Exposure (E) Total 11 Rating: R = 8.6554 K - 12.0324 - 0.1683 \* D - 0.1693 \* E

Sample Numbers (Air & Bulk): SEE EXAMPLE 4



EXAMPLE No. 6, Administrative Offices

Assessment cell: only one of many assessment cells in the entire office building.

This office is 20 ft X 20 ft with a curved ceiling, 15 feet at the center and 10 feet at the walls and is one of 15 of similar architectural design. Five people work full time. The floors are carpeted and the walls are painted plaster. The ACM is on the ceiling. According to the facility folder, work was done in this office many years ago and they scraped some of the ACM off. Now the ACM is 1/4 to 1/2 inch thick, 15-30% chrysotile, and painted white. The material is firmly bound to the ceiling but is friable. It has been damaged by water caused by a difficult to trace leak in the roof. Approximately 5 ft<sup>2</sup> of ACM is beginning to flake off and personnel in the office have reported finding these flakes on the floor and their desks. Two rows of fluorescent lights hang from the ceiling. The lights are suspended by 10 hangers. Supply air is provided to the room by an 18 inch diameter ceiling diffuser. The return air grills for the recirculating ventilation system are located in the corridor. A cloth strip attached to the diffuser indicates a strong inflow of air, but there is no evidence that this air stream is deteriorating the ACM.

AIR FORCE ASBESTOS GRADE CHECKLIST FOR SPRAYED-ON TROWELLED-ON, or DAMAGED FRIABLE MATERIAL

BASE: ANYWHERE AFB BLDG/RM NOS. 905 RM 22 FACILITY/OFFICE: PUBLIC AFFAIRS INSPECTOR (DATE) J. DOLE / AUG 86

THERE ARE NO SIMILAR OFFICES. THIS IS AN EXCEPTION BECAUSE OF THE WATER DAMAGE.

\*\*\*\*\* Part I: DAMAGE/RISK \*\*\*\*\*

- Physical Damage, Visible evidence: (5) High; (4) Moderate; (2) Low; (1) Minimal; (U) None
- Water Damage: (3) Yes; (0) No
- Proximity to Items for Repair. If both a. and b. apply, score the one with the highest rating. (Max 3 pts). How far? :  
 "a". Sprayed or Trowelled-on: (3) <1 ft or ceiling panel contam.; (2) 1-7<5 ft; (1) >5 ft; (0) >5 ft No rout. maint.  
 "b". Pipe, Boiler, or Duct Insulation, Damage by routine maint. ? : (3) ceiling panel contam.; (1) Yes; (0) No
- Type of Mat'l: (0-4) Other friable mat'l; (1) Boiler and/or pipe; (3) HVAC; (4) Ceilings or walls
- Potential for Contact: "<10 ft" (4) High; (5) Medium; (2) Low; ">10 ft" (5) High; (3) Medium; (0) Low
- Asbestos Content, % with highest prob: (1) 1%<30; (3) 30%<50; (5) >50%; NO HAZARD all samples no asbestos

Damage (D) Total 11

\*\*\*\*\* Part II: EXPOSURE \*\*\*\*\*

- Friable: (6) High; (3) Moderate; (1) Low
- Area of Visible Mat'l: (0) <10 ft<sup>2</sup>; (1) 10<ft<sup>2</sup><100; (2) 100<ft<sup>2</sup><1000; (3) >1000 ft<sup>2</sup> 20'x20' = 400 ft<sup>2</sup> ceiling.
- Walls: (4) Rough; (3) Pitted; (2) Moderate; (1) Smooth
- Ventilation (max 7 pts): (5) Interior supply; (2) Interior return; (1) Air supply-Fiber potential; (0) None
- Air Movement Affecting Mat'l: (5) Routine turbulent or abrupt air mvmt; (2) Exposed to percept air; (0) No percept air
- Activity: (5) High-constant vibs; (2) Medium-occasional vibs; (0) Low-admin office, classroom, waiting room, etc.
- Floor: (4) Carpet; (2) Seamed or rough surface; (1) Smooth continuous surface; (0-4) Unique situations
- Barriers. If both a. and b. apply, score the one with the highest rating. Check all that apply (Max of 4 pts):  
 "a". Sprayed or trowelled-on on ceiling or walls: (1) Suspend ceiling; (2) Encapsulation; (3) Railing or wire; (4) None  
 "b". Pipe, Boiler, Duct, or Other Mat'l: (1) <25%; (2) 25%<50; (3) 50%<75; (4) 75%<100
- Population: (1) <9 or for corridors; (2) 10<Pop<200; (3) 201<Pop<500; (4) 501<Pop<1000; (5) >1001 or med or youth

Exposure (E) Total 14

Rating: R = 14.0324 - 0.1683 \* 0 = 0.1693 \* E

Sample Numbers (Air & Bulk): 9M 86003a (GULK) CITY/STATE 15-30-20 CELLING R = 7.8109

EXAMPLE No. 7, Penthouse Mechanical Room

Assessment cell: there is sprayed-on ACM on the supply ducts throughout the building (see Example 10). The assessment cells for the building were determined by the condition of the ACM in the area and by the architecture (offices, corridors, patient care areas, etc.).

The penthouse is 30 ft X 30 ft X 10 ft high and sits on top of a five story building. Highly friable ACM, 5-15% chrysotile, covers three of the four sheetmetal walls. The fourth wall is made of concrete blocks and separates the room from the elevator shaft and penthouse. The room is crowded with pumps, small air handlers, and compressors. The closest piece of equipment is three feet from an ACM insulated wall. Being on the top of the building, the penthouse is subject to constant wind that can shake the walls. Also, the vibration from the machinery affects the walls. There is no damage to the ACM but the dust on the equipment appears to contain fibers. Results of recent air sampling indicate fiber concentrations as high as 0.1 f/cc. The ceiling is sheetmetal and the floor is unfinished concrete. Once per week, two maintenance men visit the penthouse to inspect the equipment and the adjacent penthouse's elevator motor and pulleys. The inspection usually takes one hour to complete. The door to the penthouse and the metal joints are well sealed to keep out rain, therefore, there are no perceptible air streams in the mechanical room penthouse.

AIR FORCE ASBESTOS GRADE CHECKLIST FOR SPRAYED-ON TROWELLED-ON, OR DAMAGED FRIABLE MATERIAL

BASE: BAF WHEEL AFB BLDG/RM NOS. 2001 FACILITY/OFFICE: HQ. W. PENTHOUSE INSPECTOR (DATE): V. DOE / AUG 86

\*\*\*\*\* Part I: DAMAGE/RISK \*\*\*\*\*

- Physical Damage, Visible evidence: (5) High; (4) Moderate; (2) Low; (1) Minimal; (0) None
- Water Damage: (3) Yes; (0) No
- Proximity to Items for Repair. If both a. and b. apply, score the one with the highest rating. (Max 3 pts). How far? :  
 "a". Sprayed or Trowelled-on: (3) <1 ft or ceiling panel contam.; (2) 1-7 < 5 ft; (1) > 5 ft; (0) > 5 ft No rout. maint.  
 "b". Pipe, Boiler, or Duct Insulation, Damage by routine maint. ? : (3) ceiling panel contam.; (1) Yes; (0) No
- Type of Mat'l: (0-4) Other friable mat'l; (1) Boiler and/or pipe; (3) HVAC; (4) Ceilings or walls
- Potential for Contact: "<10 ft" (8) High; (5) Medium; (2) Low; ">10 ft" (5) High; (3) Medium; (0) Low
- Asbestos Content, % with highest prob: (1) 1% < 30; (3) 30% < 50; (5) > 50%; NO HAZARD all samples no asbestos

Damage (0) Total 8

\*\*\*\*\* Part II: EXPOSURE \*\*\*\*\*

- Friable: (6) High; (3) Moderate; (1) Low
- Area of Visible Mat'l: (0) <10 ft<sup>2</sup>; (1) 10 < ft<sup>2</sup> < 100; (2) 100 < ft<sup>2</sup> < 1000; (3) > 1000 ft<sup>2</sup>  
(30' x 30') x 3 walls = 900 ft<sup>2</sup>
- Walls: (4) Rough; (3) Pitted; (2) Moderate; (1) Smooth
- Ventilation (max 7 pts): (5) Interior supply; (2) Interior return; (1) Air supply-Fiber potential; (0) None
- Air Movement Affecting Mat'l: (5) Routine turbulent or abrupt air mvmt; (2) Exposed to percept air; (0) No percept air
- Activity: (5) High-constant vibs; (2) Medium-occasional vibs; (0) Low-admin office, classroom, waiting room, etc.
- Floor: (4) Carpet; (2) Seamed or rough surface; (1) Smooth continuous surface; (0 4) Unique situations
- Barriers. If both a. and b. apply, score the one with the highest rating. Check all that apply (Max of 4 pts):  
 "a". Sprayed or trowelled-on on ceiling or walls: (1) Suspend ceiling; (2) Encapsulation; (3) Railing or wire; (4) None

"b". Pipe, Boiler, Duct, or Other Mat'l: (1) < 25%; (2) 25% < 50; (3) 50% < 75; (4) 75% < 100

• Population: (1) > 9 or fur corridors; (2) 10 < Pop < 200; (3) 201 < Pop < 500; (4) 501 < Pop < 1000; (5) > 1001 or med or youth

Exposure (E) Total 24 Rating: R = 12.0324 - 0.1683 \* D - 0.1693 \* L R = 6.6228

Sample Numbers (Air & Bulk): 6M 860031-33 (64 LK) CANYSOZZLE 5-15% WALLS

Pop: 2 PER WK / 5 DAY WK = 0.4 MEN/DAY ⇒ NOT A PATIENT CARE AREA.

EXAMPLE No. 8, Laboratory

Assessment cell: includes a corridor and three offices. The offices open into the corridor and the doors usually stay open.

The laboratory is a large building 150 ft long X 100 ft wide. It was constructed in the 1960s and asbestos fireproofing was sprayed on the concrete underside of the roof. This friable ACM is 30-50% chrysotile and is rather firmly bound to the substrate which is concrete. There are approximately 25 office or administrative areas, 10 corridor areas, one large open lab area, two latrines, and three storage or janitor rooms. Ten of the offices have plastered ceilings, but all the other areas have perforated ceilings. Each perforated panel is 12 in X 24 in. Resting on top of the panels is fiberglass batting which was found to cover approximately 95% of the panels. The ACM above the plastered and perforated ceilings is deteriorating with age and in some areas has been disturbed. The deterioration is not noticeable where the batting is in place, but it is noticeable when the batting is removed or where the batting is not in place. In two areas of the building, ACM could be seen coming through the panel perforations.

The assessment cell is comprised of a corridor 25 ft long, 8 ft wide, and 8 ft high to the false ceiling and three offices 20 ft X 20 ft each which have the same ceiling and open into the corridor. Three people work in each office full time. There are two panels in the corridor where the batting has been removed and ACM can be seen coming through the perforations. Examination above the ceiling revealed large chunks of ACM lying on top of the panels. There is no water damage. The walls are painted plaster and the floor covering is vinyl asbestos tile. ACM has fallen through the ceiling perforations and was found on the floor of only the corridor. There is no perceptible air flow in the corridor or the offices. The air supply grills are in the offices and the return air grills for recirculating the air are in the corridor.

AIR FORCE ASBESTOS GRADE CHECKLIST FOR SPRAYED-ON TROWELLED-ON, or DAMAGED FRIABLE MATERIAL

BASE: ANYWHERE AB BLDG/RM NOS. 1500 RM 1-3 FACILITY/OFFICE: RESEARCH LAB INSPECTOR (DATE): J. DOE / AUG 86

\*\*\*\*\* Part I: DAMAGE/RISK \*\*\*\*\*

- Physical Damage, Visible evidence: (5) High; (4) Moderate; (2) Low; (1) Minimal; (0) None
- Water Damage: (3) Yes; (0) No
- Proximity to Items for Repair. If both a. and b. apply, score the one with the highest rating. (Max 3 pts). How far? :  
 "a". Sprayed or Trowelled-on: (3) <1 ft or ceiling panel contam.; (2) 1-7.5 ft; (1) >5 ft; (0) >5 ft No rout. maint.  
 "b". Pipe, Boiler, or Duct Insulation, Damage by routine maint. : (3) ceiling panel contam.; (1) Yes; (0) No
- Type of Mat'l: (0-4) Other friable mat'l; (1) Boiler and/or pipe; (3) HVAC; (4) Ceilings or walls
- Potential for Contact: "<10 ft" (8) High; (5) Medium; (2) Low; ">10 ft" (5) High; (3) Medium; (0) Low
- Asbestos Content, % with highest prob: (1) 1%<30; (3) 30%<50; (5) >50%; NO HAZARD all samples no asbestos

Damage (D) Total 13

\*\*\*\*\* Part II: EXPOSURE \*\*\*\*\*

- Friable: (6) High; (3) Moderate; (1) Low
- Area of Viable Mat'l: (0) <10 ft<sup>2</sup>; (1) 10<ft<sup>2</sup><100; (2) 100<ft<sup>2</sup><1000; (3) >1000 ft<sup>2</sup>
- Walls: (4) Rough; (3) Pitted; (2) Moderate; (1) Smooth
- Ventilation (max 7 pts): (5) Interior supply; (2) Interior return; (1) Air supply-Fiber potential; (0) None
- Air Movement Affecting Mat'l: (5) Routine turbulent or abrupt air mvmt; (2) Exposed to percept air; (0) No percept air
- Activity: (5) High-constant vibs; (2) Medium-occasional vibs; (0) Low-admin office, classroom, waiting room, etc.
- Floor: (4) Carpet; (2) Seamed or rough surface; (1) Smooth continuous surface; (0-4) Unique situations
- Barriers. If both a. and b. apply, score the one with the highest rating. Check all that apply (Max of 4 pts):  
 "a". Sprayed or trowelled-on on ceiling or walls: (1) Suspend ceiling; (2) Encapsulation; (3) Railing or wire; (4) None

2 PANELS (1'x2') x 2 = 4 ft<sup>2</sup>

- "b". Pipe, Boiler, Duct, or Other Mat'l: (1) <25%; (2) 25%<50; (3) 50%<75; (4) 75%<100

• Population: (1) <9 or for corridors; (2) 10>Pop<200; (3) 201>Pop<500; (4) 501>Pop<1000; (5) >1001 or med or youth  
 Exposure (E) Total 8

Sample Numbers (Air & Bulk): GM 860034 (BULK) CHAY5074E 30-50 93 CELE 19  
 Rating: K - 12.0324 - 0.1683 + 0 = 0.1693 + 1 R = 8.4901

Pop: 3 PERSONNEL PER OFFICE = 9

EXAMPLE No. 9, Accessory Repair Building

Assessment cell: an entire building.

This building was constructed 40 years ago. It is 200 ft X 250 ft with a 20 ft ceiling. There are 150 full time employees spread out through the facility working at many different work stations. The work environment is open bay and involves desk top, hand tool repair. Heavy equipment is not required to move items. The floor is painted concrete, the walls are painted brick, and the ceiling is comprised of metal beams and wood. The ACM in question insulates the hundreds of feet of pipes suspended 15 to 20 ft above the work areas. The ACM is 30-50% chrysotile asbestos. The pipe lagging is in generally good shape and there is no evidence of material fallout. The three damaged pipes expose only about 10 ft<sup>2</sup> of ACM. What is exposed is very friable. Hot water space heaters provide warmth during the winter. The doors and the windows are usually left open from spring to fall for ventilation and cooling. Pedestal fans supplement indoor air movement.

Note: As noted in Example 2, once the damaged ACM is repaired, the area may be dropped from the semiannual inspection scheme. A local decision would have to be made concerning the priority of abatement associated with these small damaged areas.

AIR FORCE ASBESTOS GRADE CHECKLIST for SPRAYED-ON TROWELLED-ON, or DAMAGED FRIABLE MATERIAL

BASE: BYNTERE AB BLDG/RM NOS. 329 FACILITY/OFFICE: ACCESSORY KEVAK INSPECTOR (DATE): J. DOE 1 AUG 86

\*\*\*\*\* Part I: DAMAGE/RISK \*\*\*\*\*

- Physical Damage, Visible evidence: (5) High; (4) Moderate; (2) Low; (1) Minimal; (u) None
- Water Damage: (3) Yes; (0) No
- Proximity to Items for Repair. If both a. and b. apply, score the one with the highest rating. (Max 3 pts). How far? :  
 -a-. Sprayed or Trowelled-on: (3) <1 ft or ceiling panel contam.; (2) 1-2<5 ft; (1) >5 ft; (0) >5 ft No rout. maint.
- b-. Pipe, Boiler, or Duct Insulation, Damage by routine maint. ? : (3) ceiling panel contam.; (1) Yes; (0) No
- Type of Mat'l: (0-4) Other friable mat'l; (1) Boiler and/or pipe; (3) HVAC; (4) Ceilings or walls
- Potential for Contact: "<10 ft" (8) High; (5) Medium; (2) Low; ">10 ft" (5) High; (3) Medium; (0) Low
- Asbestos Content, % with highest prob: (1) 1%<30; (3) 30%<50; (5) >50%; NO HAZARD all samples no asbestos

Damage (D) Total 5

\*\*\*\*\* Part II: EXPOSURE \*\*\*\*\*

- Friable: (6) High; (3) Moderate; (1) Low
- Area of Visible Mat'l: (0) <10 ft<sup>2</sup>; (1) 10<ft<sup>2</sup><100; (2) 100<ft<sup>2</sup><1000; (3) >1000 ft<sup>2</sup> 2 ft<sup>2</sup>
- Walls: (4) Rough; (3) Pitted; (2) Moderate; (1) Smooth
- Ventilation (max 7 pts): (5) Interior supply; (2) Interior return; (1) Air supply-Fiber potential; (0) None
- Air Movement Affecting Mat'l: (5) Routine turbulent or abrupt air mvmt; (2) Exposed to percept air; (0) No percept air
- Activity: (5) High-constant vibs; (2) Medium-occasional vibs; (0) Low-admin office, classroom, waiting room, etc.
- Floor: (4) Carpet; (2) Seamed or rough surface; (1) Smooth continuous surface; (0-4) Unique situations
- Barriers. If both a. and b. apply, score the one with the highest rating. Check all that apply (Max of 4 pts):  
 -a-. Sprayed or trowelled-on on ceiling or walls: (1) Suspend ceiling; (2) Encapsulation; (3) Railing or wire; (4) None
- b-. Pipe, Boiler, Duct, or Other Mat'l: (1) <25%; (2) 25%<50; (3) 50%<75; (4) 75%>100
- Population: (1) <9 or for corridors; (2) 10<Pop<200; (3) 201<Pop<500; (4) 501<Pop<1000; (5) >1001 or med or youth

Exposure (E) Total 15 Rating: R = 12.0324 - 0.1683 \* D - 0.1693 \* E R = 8.6514

Sample Numbers (Air & Bulk): 6M 860035-37 (BULK) CHRYSO715E 30-50% PIPE

OPEN DOWNS FANS



EXAMPLE No. 10. Hospital

Assessment cell: corridor of a five story building (see example 7).

The 8 in X 12 in supply air ducts in the old part of this 5 story hospital are covered with sprayed-on, very friable ACM, 5-15% chrysotile. The area being inspected is a first floor carpeted corridor. The elevator is in this hallway and hospital personnel, patients, and visitors use it to access other floors. The walls are painted plaster, and the ceiling is made up entirely of perforated ceiling panels. When initially installed, the panels had fiberglass batting resting on top of them, but over the years 50% of the batting in the hallway has been removed. Inspection above the panels reveals extensive material damage and fallout. Although the ACM can be seen through the perforations, there is no visible evidence of any material fallout in the corridor. There is no evidence of any water damage. The utilities for the second floor are located in the three foot space above the paneled ceiling, and due to the age of the facility require frequent attention. This space is not used as a return air plenum, but there are return air grills for the recirculating system in the 30 ft long X 12 ft wide and 9 ft high corridor.

AIR FORCE ASBESTOS GRADE CHECKLIST FOR SPRAYED-ON TROWELLED-ON, or DAMAGED FRIABLE MATERIAL

BASE: W/INTERS AFB BLDG/RM NOS. 200 FACILITY/OFFICE: HON CONDON #12 INSPECTOR (DATE): J. DOE 1 AUG 86

\*\*\*\*\* Part I: DAMAGE/RISK \*\*\*\*\*

- Physical Damage, Visible evidence: (5) High; (4) Moderate; (2) Low; (1) Minimal; (0) None
- Water Damage: (3) Yes; (0) No
- Proximity to Items for Repair. If both a. and b. apply, score the one with the highest rating. (Max 3 pts). How far? :  
 "a". Sprayed or Trowelled-on: (3) <1 ft or ceiling panel contam.; (2) 1-7-5 ft; (1) >5 ft; (0) >5 ft No rout. maint.
- "b". Pipe, Boiler, or Duct Insulation, Damage by routine maint. ? : (3) ceiling panel contam.; (1) Yes; (0) No
- Type of Mat'l: (0-4) Other friable mat'l; (1) Boiler and/or pipe; (3) HVAC; (4) Ceilings or walls
- Potential for Contact: "<10 ft" (8) High; (5) Medium; (2) Low; ">10 ft" (5) High; (3) Medium; (0) Low
- Asbestos Content, % with highest prob: (1) 1% <= 30; (3) 30% <= 50; (5) >50%; NO HAZARD all samples no asbestos

Damage (0) Total 10

\*\*\*\*\* Part II: EXPOSURE \*\*\*\*\*

- Friable: (6) High; (3) Moderate; (1) Low
- Area of Visible Mat'l: (0) <10 ft<sup>2</sup>; (1) 10 <= ft<sup>2</sup> < 100; (2) 100 <= ft<sup>2</sup> < 1000; (3) >1000 ft<sup>2</sup>
- Walls: (4) Rough; (3) Pitted; (2) Moderate; (1) Smooth
- Ventilation (max 7 pts): (5) Interior supply; (2) Interior return; (1) Air supply-Fiber potential; (0) None
- Air Movement Affecting Mat'l: (5) Routine turbulent or abrupt air mvmt; (2) Exposed to percept air; (0) No percept air
- Activity: (5) High-constant vibs; (2) Medium-occasional vibs; (0) Low-admin office, classroom, waiting room, etc.
- Floor: (4) Carpet; (2) Seamed or rough surface; (1) Smooth continuous surface; (0-4) Unique situations
- Barriers. If both a. and b. apply, score the one with the highest rating. Check all that apply (Max of 4 pts):  
 "a". Sprayed or trowelled-on on ceiling or walls: (1) Suspend ceiling; (2) Encapsulation; (3) Railing or wire; (4) None

"b". Pipe, Boiler, Duct, or Other Mat'l: (1) <25%; (2) 25% <= 50; (3) 50% <= 75; (4) 75% <= 100

• Population: (1) <9 or for corridors; (2) 10 <= Pop < 200; (3) 201 <= Pop < 500; (4) 501 <= Pop < 1000; (5) >1001 or med or youth

Exposure (E) Total 20 Rating: R = 12.0324 - 0.1683 \* U - 0.1693 \* E R = 6.9634

Sample Numbers (Air & Bulk): 6A B60038 (BULK) CHY/SO7LE 5-15-86 DUST INSULATION

HALLWAY IS 30'x12' = 360 ft<sup>2</sup>  
MAT'L IS SEEN THRU 50%  
OF THE CEILING ANSWERS  
1/2 x 360 ft<sup>2</sup> = 180 ft<sup>2</sup> EXPOS

EXAMPLE No. 11, Kitchen

Assessment cell: this is the only area within the building that has exposed ACM, therefore, the only assessment cell.

The assessment area is a large kitchen which has a floor area of 4800 ft<sup>2</sup> (80 ft long X 60 ft wide X 10 ft high to the suspended ceiling). There are 30 workers assigned. The entire ceiling above the suspended 2 ft X 4 ft panels is covered with a fluffy sprayed-on ACM, 15-30% chrysotile. There is little evidence of material fallout on the top of the panels except by the exhaust ducts where there are small pieces resting on top of the panels. ACM is exposed because eight panels are missing. Four panels alone are missing from the area above the soup steam kettle. This kettle is used daily and is cleaned daily with a steam hose. The exposed ACM above the kettle appears damaged when compared to the other ACM condition. Workers have said they've seen insulation on the floor in the kettle area which indicates the ACM is deteriorating. There are three large wall exhaust fans and multiple exhaust hoods to remove the heat and food odors. The walls are tiled and the floor is covered with a special nonskid easy-to-clean tile. There are no utilities above the ceiling except for the exhaust ducts. The exhaust system including the fans on the roof are inspected and checked routinely.

AIR FORCE ASBESTOS GRADE CHECKLIST FOR SPRAYED-ON TROWELLED-ON, OR DAMAGED FRIABLE MATERIAL

BASE: RAJAWHERE AFB BLDG/RM NOS. 400 FACILITY/OFFICE: KITCHEN INSPECTOR (DATE): JD DOE / AUG 86

\*\*\*\*\* Part I: DAMAGE/RISK \*\*\*\*\*

- Physical Damage, Visible evidence: (5) High; (4) Moderate; (2) Low; (1) Minimal; (0) None **KETTLE AREA**
- Water Damage: (3) Yes; (0) No
- Proximity to Items for Repair. If both a. and b. apply, score the one with the highest rating. (Max 3 pts). How far? : **EXHAUST DUCT LOCATION**
- "a". Sprayed or Trowelled-on: (3) <1 ft or ceiling panel contam.; (2) 1-7<5 ft; (1) >5 ft; (0) >5 ft No rout. maint.
- "b". Pipe, Boiler, or Duct Insulation, Damage by routine maint. ? : (3) ceiling panel contam.; (1) Yes; (0) No
- Type of Mat'l: (0-4) Other friable mat'l; (1) Boiler and/or pipe; (3) HVAC; (4) Ceilings or walls
- Potential for Contact: "<10 ft" (8) High; (5) Medium; (2) Low; ">10 ft" (5) High; (3) Medium; (0) Low
- Asbestos Content, % with highest prob: (1) 1<%<30; (3) 30<%<50; (b) >50%; NO HAZARDOUS samples no asbestos

Damage (0) Total 15

\*\*\*\*\* Part II: EXPOSURE \*\*\*\*\*

- Friable: (6) High; (3) Moderate; (1) Low
- Area of Visible Mat'l: (0) <10 ft<sup>2</sup>; (1) 10<ft<sup>2</sup><100; (2) 100<ft<sup>2</sup><1000; (3) >1000 ft<sup>2</sup>
- Walls: (4) Rough; (3) Pitted; (2) Moderate; (1) Smooth
- Ventilation (max 7 pts): (5) Interior supply; (2) Interior return; (1) Air supply-Fiber potential; (0) None
- Air Movement Affecting Mat'l: (5) Routine turbulent or abrupt air mvmt; (2) Exposed to percept air; (0) No percept air **HEAT DUCT VIBE**
- Activity: (5) High-constant vibs; (2) Medium-occasional vibs; (0) Low-admin office, classroom, waiting room, etc.
- Floor: (4) Carpet; (2) Seamed or rough surface; (1) Smooth continuous surface; (0-4) Unique situations
- Barriers. If both a. and b. apply, score the one with the highest rating. Check all that apply (Max of 4 pts):
- "a". Sprayed or trowelled-on on ceiling or walls: (1) Suspend ceiling; (2) Encapsulation; (3) Rattling or wire; (4) None
- "b". Pipe, Boiler, Duct, or Other Mat'l: (1) <25%; (2) 25<%<50; (3) 50<%<75; (4) 75<%<100
- Population: (1) <9 or for corridors; (2) 10<Pop<200; (3) 201<Pop<500; (4) 501<Pop<1000; (5) >1001 or med or youth

Exposure (E) Total 16

Rating: R = 12.0324 - 0.1683 \* D - 0.1693 \* E **R = 6.7991**  
Sample Numbers (Air & Bulk): 6M 860039-41 (Bulk) SAMPLES 39-41 515-20 CHRYSTLE CELL **PC SALT**  
QC 6M 860042 (SPLT OF #40) 42 **"**

EXAMPLE No. 12, Junior High School Gymnasium

Assessment cell: includes a basketball court and banked track and a set of bleachers for spectators or class instruction.

The court, track, and bleacher area is approximately 150 ft X 80 ft X 35 ft high. The entire ceiling area was insulated with a highly friable ACM which is 15-30% chrysotile asbestos. This building is old and has been abused by the weather and the children. There are numerous areas of water damage caused by the leaky roof and occasionally morning classes will be delayed while the janitors clean-up the ACM that has fallen from the ceiling. One of the favorite diversions of the students waiting for class to begin is basketball tossing, not at the basket but at the ceiling. The point of this exercise is to dislodge the biggest ACM piece without breaking the incandescent metal dome style lights. Of course, the students do hit the lights which must be fixed on almost a daily basis. While replacing the lights and fixtures, the maintenance crews make direct contact with the ACM resting on top of the dome.

The walls of the structure are painted concrete block and the floor is varnished hardwood. To conserve energy, a recirculating ventilation system is employed. The heating system is supplemented by ceiling mounted space heaters which blow down. When working, the air flow from these units is perceptible.

The gym is used five days per week and during the winter it is used by a local basketball league.

AIR FORCE ASBESTOS GRADE CHECKLIST FOR SPRAYED-ON TROWELLED-ON, or DAMAGED FRIABLE MATERIAL

BASE: ADJUTANT GENERAL BLDG/WM NOS. 326 FACILITY/OFFICE: TR. HIGH SYD INSPECTOR (DATE): J. DOE 1 AUG 86

\*\*\*\*\* Part I: DAMAGE/RISK \*\*\*\*\*

- Physical Damage, Visible evidence: (5) High; (4) Moderate; (2) Low; (1) Minimal; (0) None
- Water Damage: (3) Yes; (0) No
- Proximity to Items for Repair. If both a. and b. apply, score the one with the highest rating. (Max 3 pts). How far? :  
 "a". Sprayed or Trowelled-on: (3) <1 ft or ceiling panel contam.; (2) 1-7 < 5 ft; (1) > 5 ft; (0) > 5 ft No rout. maint.
- "b". Pipe, Boiler, or Duct Insulation, Damage by routine maint. ? : (3) ceiling panel contam.; (1) Yes; (0) No
- Type of Mat'l: (0-4) Other friable mat'l; (1) Boiler and/or pipe; (3) HVAC; (4) Ceilings or walls
- Potential for Contact: "<10 ft" (8) High; (5) Medium; (2) Low; >10 ft" (5) High; (3) Medium; (0) Low
- Asbestos Content, % with highest prob: (1) 1-30; (3) 30-50; (5) >50; NO HAZARD all samples no asbestos

Damage (D) Total 20

\*\*\*\*\* Part II: EXPOSURE \*\*\*\*\*

- Friable: (6) High; (3) Moderate; (1) Low
- Area of Visible Mat'l: (0) <10 ft<sup>2</sup>; (1) 10-100; (2) 100-1000; (3) >1000 ft<sup>2</sup> 150' x 80' = 12,000 ft<sup>2</sup>
- Walls: (4) Rough; (3) Pitted; (2) Moderate; (1) Smooth
- Ventilation (max 7 pts): (5) Interior supply; (2) Interior return; (1) Air supply-fiber potential; (0) None
- Air Movement Affecting Mat'l: (5) Routine turbulent or abrupt air mvmt; (2) Exposed to percept air; (0) No percept air
- Activity: (5) High-constant vibs; (2) Medium-occasional vibs; (0) Low-admin office, classroom, waiting room, etc.
- Floor: (4) Carpet; (2) Seamed or rough surface; (1) Smooth continuous surface; (0-4) Unique situations
- Barriers. If both a. and b. apply, score the one with the highest rating. Check all that apply (Max of 4 pts):  
 "a". Sprayed or trowelled-on on ceiling or walls: (1) Suspend ceiling; (2) Encapsulation; (3) Rattling or wire; (4) None
- "b". Pipe, Boiler, Duct, or Other Mat'l: (1) <25%; (2) 25-50; (3) 50-75; (4) 75-100
- Population: (1) <50 or for corridors; (2) 50-200; (3) 200-500; (4) 500-1000; (5) >1000 or med or youth
- Exposure (E) Total 24 Rating: R = 12.0324 - 0.1683 \* D - 0.1683 \* E R = 4.6032
- Sample Numbers (Air & Bulk): GM 860043-45 CAMPUS/OTIS 15-30 20 CEILING

EXAMPLE No. 13, Office

Assessment cell: Office

This 20 ft X 30 ft X 10 ft high office sits alone. There are ten ACM insulated pipes in the area which come down from the ceiling and bend into five wall heating units. The only visible damage is on one of the bends. The 5-15% amosite-containing ACM elbow insulation was inadvertently damaged by one of the eight assigned personnel. This resulted in a "one-dollar-bill" sized frayed surface of moderately friable ACM. The remaining length of insulated pipe are covered with painted lagging which has a bridged hard surface. Maintenance men rarely are required to fix the elbow areas. The workers whose desks are close to the window units are careful not to damage the ACM. There is no water damage to any of the covering or pipes.

The walls are painted sheetrock and the floor is carpeted. Air movement in the office is minimal and the ventilation is usually imperceptible unless the windows are opened.

Note: Another small damaged area similar to Examples 2 and 9.

AIR FORCE ASBESTOS GRADE CHECKLIST FOR SPRAYED-ON TROWELLED-ON, OR DAMAGED FRIABLE MATERIAL

BASE: ANYWHERE AFB BLDG/RM NOS. 2002 FACILITY/OFFICE: OFFICE BLDG INSPECTOR (DATE): J. DOE 1 AUG 86

\*\*\*\*\* Part I: DAMAGE/RISK \*\*\*\*\*

- Physical Damage, Visible evidence: (5) High; (4) Moderate; (2) Low; (1) Minimal; (U) None
- Water Damage: (3) Yes; (0) No
- Proximity to Items for Repair. If both a. and b. apply, score the one with the highest rating. (Max 3 pts). How far? :  
 "a". Sprayed or Trowelled-on: (3) <1 ft or ceiling panel contam.; (2) 1-7-5 ft; (1) >5 ft; (0) >5 ft No rout. maint.  
 "b". Pipe, Boiler, or Duct Insulation, Damage by routine maint. ? : (3) ceiling panel contam.; (1) Yes; (0) No
- Type of Mat'l: (0-4) Other friable mat'l; (1) Boiler and/or pipe; (3) HVAC; (4) Ceilings or walls
- Potential for Contact: "<10 ft" (8) High; (5) Medium; (2) Low; ">10 ft" (5) High; (3) Medium; (0) Low
- Asbestos Content, % with highest prob: (1) 1%<30; (3) 30%<50; (5) >50%; NO HAZARD all samples no asbestos

Damage (0) Total 5

\*\*\*\*\* Part II: EXPOSURE \*\*\*\*\*

- Friable: (6) High; (3) Moderate; (1) Low
- Area of Visible Mat'l: (0) <10 ft<sup>2</sup>; (1) 10<ft<sup>2</sup><100; (2) 100<ft<sup>2</sup><1000; (3) >1000 ft<sup>2</sup> **"ONE DOLLAR BILL" SIZE**
- Walls: (4) Rough; (3) Pitted; (2) Moderate; (1) Smooth
- Ventilation (max 7 pts): (5) Interior supply; (2) Interior return; (1) Air supply-fiber potential; (0) None
- Air Movement Affecting Mat'l: (5) Routine turbulent or abrupt air mvmt; (2) Exposed to percept air; (0) No percept air
- Activity: (5) High-constant vibs; (2) Medium-occasional vibs; (0) Low-admin office, classroom, waiting room, etc.
- Floor: (4) Carpet; (2) Seamed or rough surface; (1) Smooth continuous surface; (0-4) Unique situations
- Barriers. If both a. and b. apply, score the one with the highest rating. Check all that apply (Max of 4 pts):  
 "a". Sprayed or trowelled-on on ceiling or walls: (1) Suspend ceiling; (2) Encapsulation; (3) Railing or wire; (4) None  
 "b". Pipe, Boiler, Duct, or Other Mat'l: (1) <25%; (2) 25%<50; (3) 50%<75; (4) 75%<100
- Population: (1) <9 or for corridors: (2) 10<Pop<200; (3) 201<Pop<500; (4) 501<Pop<1000; (5) >1001 or med or youth

Exposure (E) Total 10

Rating: R = 12.0324 - 0.1683 \* D - 0.1693 \* E **R = 9.4979**  
Sample Numbers (Air & Bulk): 501 800 46 (BULK) AMOSITE 5-15% E-BAW INSULATION



EXAMPLE No. 14, Offices

Assessment cell: Group of five offices in the building.

This 50 ft X 50 ft X 20 ft high structure contains five offices - four offices each occupied by one civilian personnel supervisor, and, in the fifth office, two secretaries. The offices were recently constructed in the space which was used previously as a storage area. The facility is not completed and one of the items missing because of lack of funds is carpeting. Presently, the floor is covered with tile which the workers say is not as acceptable as carpeting. The ACM of concern is located above the false ceiling. The old steam and water pipes were not removed during the renovation. The pipe insulation is in excellent shape because they were sealed with a bridging encapsulant as part of the project. The false ceiling was put in place after the encapsulation was done. Under the encapsulant the ACM is moderately friable and is composed of 5-15% amosite asbestos. The false ceiling hiding the pipes is 8 feet above the floor. The pipes are located about 18-20 feet above the floor.

Since the facility has been completed there have not been any visits made by maintenance crews. The painted sheetrock walls and the recessed lighting have been working fine; however, the secretaries have been complaining about the lack of ventilation in the building. The hot water system feeds the window units in the offices and the only flow of air is via natural convection. The secretaries complain that their room is stuffy, but the other personnel have no complaints. The local BEE thinks this Tight Building Syndrome complaint may be a result of the secretaries not having windows in their room.

Note: The ACM is undamaged. This area did not have to be rated.

AIR FORCE ASBESTOS GRADE CHECKLIST FOR SPRAYED-ON TROWELLED-ON, or DAMAGED FRIABLE MATERIAL

BASE: ANYWHERE ABF BLOG/RM NOS. 1800 FACILITY/OFFICE: OFFICE CIV PER. INSPECTOR (DATE) J. DOE 1 AUG 16

\*\*\*\*\* Part I: DAMAGE/RISK \*\*\*\*\*

- Physical Damage, Visible evidence: \_\_\_ (5) High; \_\_\_ (4) Moderate; \_\_\_ (2) Low; \_\_\_ (1) Minimal;  (0) None
- Water Damage: \_\_\_ (3) Yes;  (0) No
- Proximity to Items for Repair. If both a. and b. apply, score the one with the highest rating. (Max 3 pts). How far? :  
 "a". Sprayed or Trowelled-on: \_\_\_ (3) <1 ft or ceiling panel contam.; \_\_\_ (2) 1-2<5 ft; \_\_\_ (1) >5 ft; \_\_\_ (0) >5 ft No rout. maint.
- "b". Pipe, Boiler, or Duct Insulation, Damage by routine maint. : \_\_\_ (3) ceiling panel contam.; \_\_\_ (1) Yes;  (0) No
- Type of Mat'l: \_\_\_ (0-4) Other friable mat'l;  (1) Boiler and/or pipe; \_\_\_ (3) HVAC; \_\_\_ (4) Ceilings or walls
- Potential for Contact: "<10 ft" \_\_\_ (8) High; \_\_\_ (5) Medium; \_\_\_ (2) Low; ">10 ft" \_\_\_ (5) High; \_\_\_ (3) Medium;  (0) Low
- Asbestos Content, % with highest prob:  (1) 1%<30; \_\_\_ (3) 30%<50; \_\_\_ (5) >50%; NO HAZARD all samples no asbestos

Damage (D) Total 2

\*\*\*\*\* Part II: EXPOSURE \*\*\*\*\*

- Friable: \_\_\_ (6) High; \_\_\_ (3) Moderate;  (1) Low ENCAPSULATED (GIVEN A 1 FOR EXERCISE PURPOSES).
- Area of Visible Mat'l:  (0) <10 ft<sup>2</sup>; \_\_\_ (1) 10<ft<sup>2</sup><100; \_\_\_ (2) 100<ft<sup>2</sup><1000; \_\_\_ (3) >1000 ft<sup>2</sup> NO DAMAGED OR EXPOSED AREA
- Walls: \_\_\_ (4) Rough; \_\_\_ (3) Pitted; \_\_\_ (2) Moderate;  (1) Smooth
- Ventilation (max 7 pts): \_\_\_ (5) Interior supply; \_\_\_ (2) Interior return; \_\_\_ (1) Air supply-Fiber potential;  (0) None
- Air Movement Affecting Mat'l: \_\_\_ (5) Routine turbulent or abrupt air mvmt; \_\_\_ (2) Exposed to percept air;  (0) No percept air
- Activity: \_\_\_ (5) High-constant vibs; \_\_\_ (2) Medium-occasional vibs; \_\_\_ (0) Low-admin office, classroom, waiting room, etc.
- Floor: \_\_\_ (4) Carpet; \_\_\_ (2) Seamed or rough surface;  (1) Smooth continuous surface; \_\_\_ (0-4) Unique situations
- Barriers. If both a. and b. apply, score the one with the highest rating. Check all that apply (Max of 4 pts):

"a". Sprayed or trowelled-on on ceiling or walls: \_\_\_ (1) Suspend ceiling; \_\_\_ (2) Encapsulation; \_\_\_ (3) Railing or wire; \_\_\_ (4) None

"b". Pipe, Boiler, Duct, or Other Mat'l:  (1) <25%; \_\_\_ (2) 25%<50; \_\_\_ (3) 50%<75; \_\_\_ (4) 75%<100 NO DAMAGE

• Population:  (1) <9 or for corridors; \_\_\_ (2) 10<Pop<200; \_\_\_ (3) 201<Pop<500; \_\_\_ (4) 501<Pop<1000; \_\_\_ (5) >1001 or med or youth; Exposure (E) Total 5

Rating: R = 12.0324 - 0.1683 \* D - 0.1693 \* E

R = 10.8523

Sample Numbers (Air & Bulk): ALDS RECORDS INDICATE INSULATION IS 5-15-20 ANALYZE

EXAMPLE No. 15, Mechanical Room

Assessment cell: the entire mechanical room.

This is a big boiler room. It is 100 ft X 90 ft X 25 ft high. There are two large boilers, five air handlers (AHUs), and hundreds of feet of ACM insulated pipe. Each boiler has approximately 600 ft<sup>2</sup> of ACM covering it. The AHUs each have about 100 ft<sup>2</sup> of ACM. There is approximately 100 ft<sup>2</sup> of highly damaged ACM on the AHUs and boilers and about 30 ft<sup>2</sup> on the pipes. Much of this is a result of boiler and pipe water damage. Since the systems in the mechanical room are old, routine maintenance must be accomplished. In the past, the workers were not careful about removing asbestos from the pipes, boilers, AHUs or the finished concrete floor. The moderately friable 30-50% amosite ACM covering the pipes and boilers and the 60% chrysotile covering the AHUs can be seen in the chinks of the pitted walls.

There are normally five men in the mechanical room who do frequent maintenance on the ACM covered boilers and perform daily inspections. The room is usually hot and this hot air is exhausted through five large propeller fans. The make-up air flowing into the room comes from the first floor of the hospital above. The heat from the boilers, the vibration and noise from the AHUs and clanging pipes and boilers make the area a terrible working environment. The asbestos just adds to the misery of the area.

AIR FORCE ASBESTOS GRADE CHECKLIST FOR SPRAYED OR TROWELLED ON, or DAMAGED FRIABLE MATERIAL

BASE: ANYWHERE AB BLDG/RM NOS. 1600 FACILITY/OFFICE: MECH RM - Hall INSPECTOR (DATE): J. DOE 1 AUG 86

\*\*\*\*\* Part I: DAMAGE/RISK \*\*\*\*\*

- Physical Damage, Visible evidence:  (5) High;  (4) Moderate;  (2) Low;  (1) Minimal;  (0) None
- Water Damage:  (3) Yes;  (0) No
- Proximity to Items for Repair. If both a. and b. apply, score the one with the highest rating. (Max 3 pts). How far? :
  - "a". Sprayed or Trowelled-on:  (3) <1 ft or ceiling panel contam.;  (2) 1-7.5 ft;  (1) >5 ft;  (0) >5 ft No rout. maint.
  - "b". Pipe, Boiler, or Duct Insulation, Damage by routine maint. ? :  (3) ceiling panel contam.;  (1) Yes;  (0) No
- Type of Mat'l:  (0-4) Other friable mat'l;  (1) Boiler and/or pipe;  (3) HVAC;  (4) Ceilings or walls
- Potential for Contact: "<10 ft"  (8) High;  (5) Medium;  (2) Low; ">10 ft"  (5) High;  (3) Medium;  (0) Low
- Asbestos Content, % with highest prob:  (1) 1%<30;  (3) 30%<50;  (5) >50%; NO HAZARD all samples no asbestos

Damage (D) Total 21 \*\*\*\*\* Part II: EXPOSURE \*\*\*\*\*

- Friable:  (6) High;  (3) Moderate;  (1) Low
- Area of Visible Mat'l:  (0) <10 ft<sup>2</sup>;  (1) 10<ft<sup>2</sup><100;  (2) 100<ft<sup>2</sup><1000;  (3) >1000 ft<sup>2</sup> 600 ft<sup>2</sup> x 2 = 1200 ft<sup>2</sup>  
100 ft<sup>2</sup> x 5 = 500 ft<sup>2</sup>  
1700 ft<sup>2</sup> + Pipes
- Walls:  (4) Rough;  (3) Pitted;  (2) Moderate;  (1) Smooth
- Ventilation (max 7 pts):  (5) Interior supply;  (2) Interior return;  (1) Air supply-Fiber potential;  (0) None
- Air Movement Affecting Mat'l:  (5) Routine turbulent or abrupt air mvmt;  (2) Exposed to percept air;  (0) No percept air
- Activity:  (5) High-constant vibs;  (2) Medium-occasional vibs;  (0) Low-admin office, classroom, waiting room, etc.
- Floor:  (4) Carpet;  (2) Seamed or rough surface;  (1) Smooth continuous surface;  (0-4) Unique situations
- Barriers. If both a. and b. apply, score the one with the highest rating. Check all that apply (Max of 4 pts):
  - "a". Sprayed or trowelled-on on ceiling or walls:  (1) Suspend ceiling;  (2) Encapsulation;  (3) Rattling or wire;  (4) Nails
  - "b". Pipe, Boiler, Duct, or Other Mat'l:  (1) >25%;  (2) 25%<50;  (3) 50%<75;  (4) 75%<100 430 ft<sup>2</sup> / 1700 ft<sup>2</sup> = 25%  
worst case
- Population:  (1) <9 or for corridors;  (2) 10<Pop<200;  (3) 201<Pop<500;  (4) 501<Pop<1000;  (5) >1001 or med or youth

Exposure (E) Total 17 Rating: R = 12.0324 - 0.1683 \* D - 0.1693 \* E R = 5.6200

Sample Numbers (Air & Bulk): 6m 860047-58 SAMPLES 47-53 PIPE & BOILER 30-50'S AMAS-77  
54-58 AHU'S 60% emey/so/77

Distribution List

	No. of copies
HQ AFSC/SGPB Andrews AFB DC 20334-5001	9
HQ USAF/SGPA Bolling AFB DC 20332-6188	1
AAMRL/TH Wright-Patterson AFB OH 45433-6573	1
USAF Regional Medical Center Wiesbaden/SGB APO New York 09220-5300	1
OL AD, USAFOEHL APO San Francisco 96274-5000	1
USAFSAM/TSK/EDH Brooks AFB TX 78235-5301	2
Defense Technical Information Center (DTIC) Cameron Station Alexandria VA 22314	2
HQ USAFE/SGPA APO New York 09012-5001	27
HQ PACAF/SGPA APO San Francisco 96853-5001	10
HQ AAC/SGPB Elmendorf AFB AK 99506-5300	4
HQ AFLC/SGPB Wright-Patterson AFB OH 45433-5001	7
HQ MAC/SGPB Scott AFB IL 62221-5001	15
HQ SAC/SGPB Offutt AFB NE 68113-5001	26
HQ ANGSC/SG Andrews AFB DC 20331-6008	70
HQ AFRes/SGPB Robins AFB GA 31098-6001	7
USAF Academy Hospital/SGPB Air Force Academy CO 80840-5470	2

Distribution List (cont'd)

	No. of copies
USAF Regional Hospital Maxwell/SGPB Maxwell AFB AL 36112-5304	2
HQ TAC/SGPB Langley AFB VA 23665-5001	44
HQ SPACECOM/SGPB Peterson AFB CO 80914-5001	3
HQ ATC/SGPB Randolph AFB TX 78150-5001	13
HQ AFESC/DEM Tyndall AFB FL 32403-5000	1
SD/SGX P.O. Box 92960 Worldway Postal Center Los Angeles CA 90009-2960	1