

DD-A172 342

DIRECT DIGITAL CONTROL OF HVAC (HEATING VENTILATING
AIR CONDITIONING) (U) NAVAL CIVIL ENGINEERING LAB PORT
HUENEME CA R E KIRTS JAN 85

UNCLASSIFIED

F/G 13/1

NE

END
DATE
FILMED
1186
DTIC

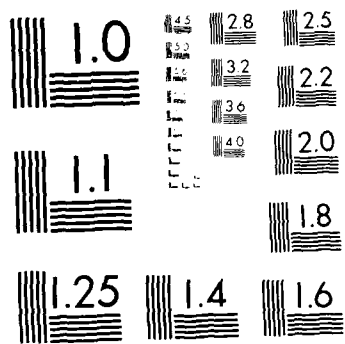

XEROCOPY RESOLUTION TEST CHART
NATIONAL BUREAU OF STANDARDS 1963-A

UG - 0004

S **D**
D T I C
E L E C T E
S E P 2 3 1 9 8 6
D

January 1985



D
USER'S GUIDE TO

DIRECT **D**IGITAL **C**ONTROL

AD-A172 342 OF HVAC EQUIPMENT

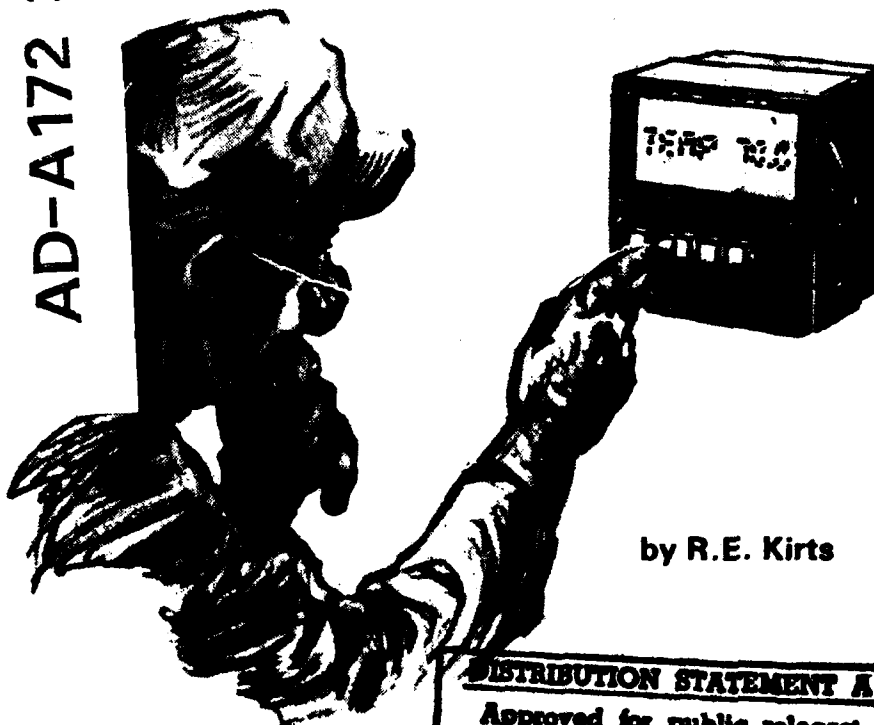

by R.E. Kirts

DISTRIBUTION STATEMENT A
Approved for public release
Distribution Unlimited

DTIC FILE COPY

Sponsored by the Naval Facilities Engineering Command

86 9 23 007

Naval Civil Engineering Laboratory
Port Hueneme, California 93043

Approved for public release; distribution unlimited

CONTENTS

	Page
I. INTRODUCTION	1
II. BACKGROUND	1
III. FUNDAMENTALS	2
IV. APPLICATIONS	35
V. SUMMARY	65
REFERENCES	67

APPENDIXES

- A - Proportional-Integral-Derivative Control A-1
- B - Control System Tuning B-1



Accession For	
NTIS CRA&I	<input checked="" type="checkbox"/>
DTIC TAB	<input type="checkbox"/>
Unannounced	<input type="checkbox"/>
Justification	
By <i>perform 50</i>	
Distribution/	
Availability Codes	
Dist	Avail and/or Special
<i>A-1</i>	

I. INTRODUCTION

Heating, ventilating, and air conditioning (HVAC) systems are now under going the most significant change in control technology in the past 100 years. This change is the introduction of direct digital control (DDC) to HVAC systems. Computer control has been introduced to many things over the past few years, from automobile engines to home appliances to most industrial processes, but only recently have small computer control systems been introduced into the space conditioning industry. To understand the implications of this new HVAC control technology, it is necessary to consider several questions:

What is DDC and what are its capabilities?

Under what conditions is DDC a cost effective alternative to conventional control?

What constitutes good system design and installation practice?

This report addresses these questions by presenting information which describes DDC, presents its advantages and disadvantages, and gives applications guidance.

II. BACKGROUND

Direct digital control is becoming an important factor in the new construction and retrofit market for HVAC controls for several reasons: energy savings through improved control, improved control system reliability, and easier maintenance.

As applied to HVAC systems, direct digital control is direct computer control of a device such as a valve or damper actuator. In a DDC system, the computer accepts data from sensors measuring variables such as temperature, humidity, and pressure, performs calculations on these data to determine the correct output response, then sends a control signal directly to the controlled device.

DDC has been expanding into the chemical, food, and metals process industries steadily for about the past 10 years until today it has virtually supplanted conventional pneumatic controllers. In the process, DDC has proven itself to be reliable, flexible, easy to use and maintain, and cost effective. Where and when a DDC control system should be installed in an HVAC system is, at the present time, a function of the complexity of the system to be controlled. At the present time, DDC is most cost effective in larger, complex HVAC systems, but the HVAC system size for cost effective DDC application is rapidly decreasing.

III. FUNDAMENTALS

What is DDC?

Direct digital control uses a programmable digital computer to process information for the purpose of determining the correct control action. The input information for the computer comes from analog sensors (such as temperature sensors) and digital sensors (such as switches). This information is used as variable data in a predetermined set of instructions called the control program. The control program calculates different values for control parameters and takes different paths in the logic of the program depending upon the values of the input variables.

After the computer completes its calculations, the appropriate value of control signal is output either in analog form (such as a voltage between 0 and 10 volts) or in digital form (such as a switch closure). The complete input-calculation-output sequence is usually repeated several times every minute. Because of this repetitive rather than continuous processing of input data, a DDC control system is called a "sampled data system." These concepts are illustrated in Figure 1.

The word "direct" in direct digital control implies that the controller has immediate control over the final control element. This is in contrast to a conventional energy monitoring and control system (EMCS) in which a computer acts only through a conventional pneumatic or analog electronic control system to actuate the final control element.

The word "digital" in direct digital control means that input data are converted into digital form, i.e., a discrete number, so that they may be operated on by a sequence of instructions called a computer program. The output from the program is also a number, which may be displayed on an output device for information purposes or converted to a continuous (or analog) output such as a voltage.

Direct digital control should not be confused with analog electronic control (Figure 2). An analog electronic controller is the electronic equivalent of a conventional pneumatic controller. As a consequence, each analog electronic controller is designed to perform only one specific function. Thus, an HVAC control system which uses analog devices must be built up from a number of interconnected special purpose devices to obtain the desired system performance. Analog electronic devices use operational amplifiers, voltage dividers, and other analog components to

produce an output signal which has a fixed relationship to the input signal. For example, the output might be the difference between two input signals multiplied by a constant. The output is also a continuous function of the input. This is to be contrasted with a DDC controller in which a computer "takes a look" at the inputs, follows one of several different logical paths depending upon the values of the inputs, and generates an output (or outputs) accordingly. Figures 1 and 2 illustrate these differences.

What's the difference between DDC
and an EMCS System?

A conventional energy monitoring and control system is used when centralized monitoring and a supervisory level of remote control are desired in an HVAC control system. A central computer communicates with a remotely located electronic device (usually called FID, for field interface device) which provides the computer with data on local conditions, such as temperature or motor status, and which can relay signals from the central computer to the local HVAC control system to do things such as change the set point of a pneumatic two-input controller. An EMCS system is usually designed to provide detailed status and alarm reports and log system data for trend analyses and energy savings calculations. The key distinction to be made is that in an EMCS system, control of the individual devices (such as valves, dampers, or fan speed) remains with a local, more or less independent, control system. These local control systems are often called "local loop controllers." The local loop controllers may be either pneumatic, electric, analog or digital electronic. Thus, a DDC local loop controller may or may not be connected to an EMCS system. The relationship between DDC and EMCS is illustrated in Figure 3.

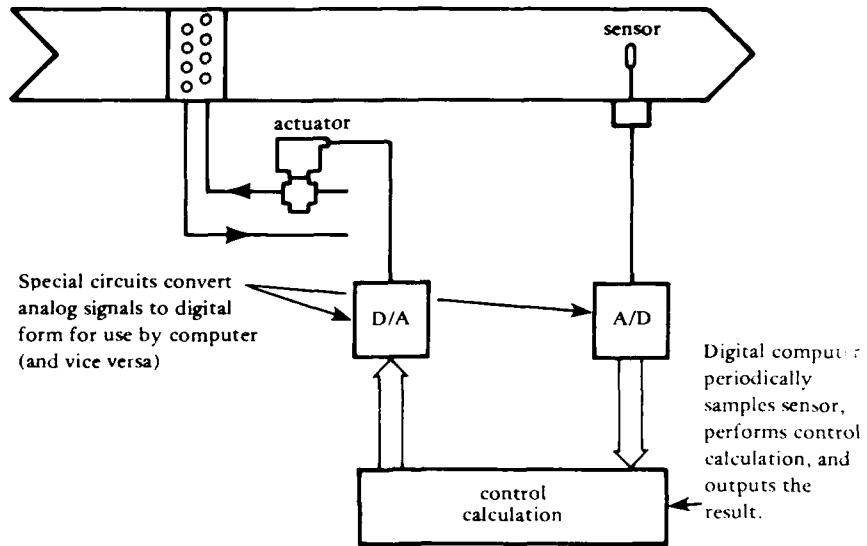

Figure 1. A digital control system.

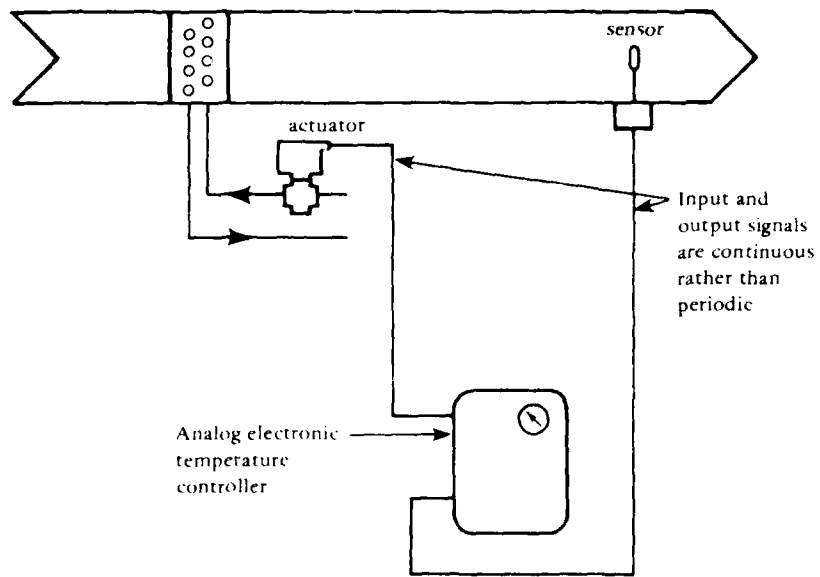
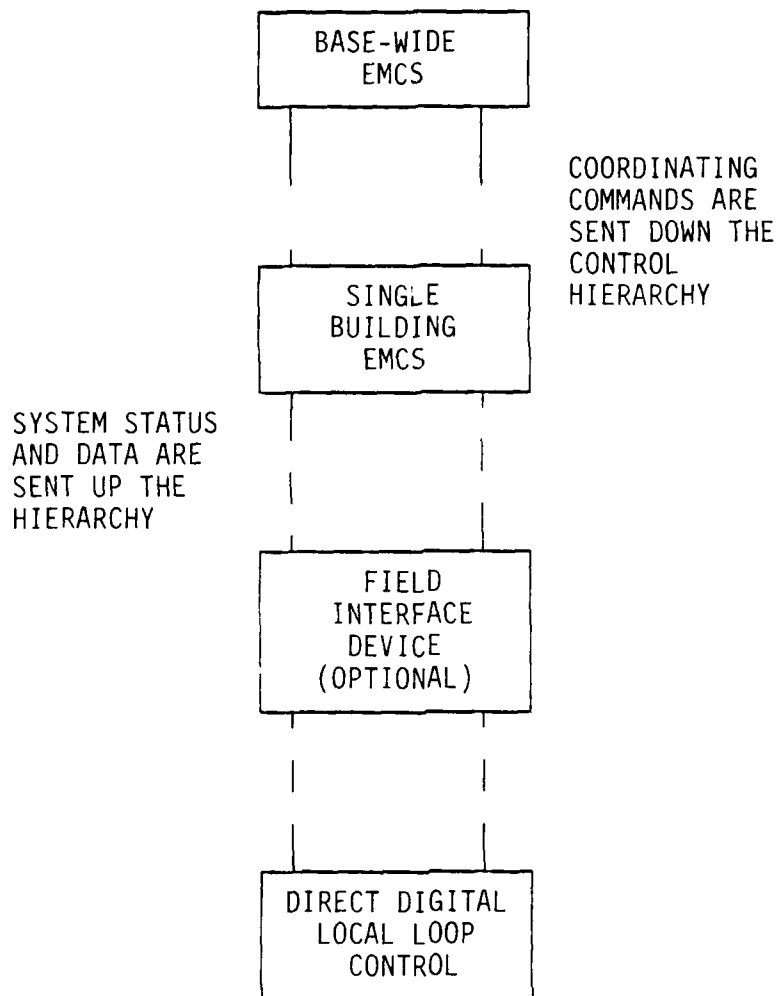

Figure 2. An analog control system.



IF FUNCTIONING OF LOCAL CONTROL IS INDEPENDENT
OF OTHER DEVICES, CONTROL IS SAID TO BE
DISTRIBUTED CONTROL

Figure 3. Relationship between DDC and EMCS.

What are the Advantages and Disadvantages of DDC?

The major advantage of direct digital control is that one programmable unit can be made to perform almost an infinite variety of control functions. If, at some later date, the control system needs to be modified, changing a DDC system is mostly a matter of changing the computer program, whereas changing a pneumatic or analog electronic control system could require major replacement and rewiring of components. This is illustrated in Figures 4 and 5 where pneumatic and DDC control systems are compared in the same application.

Another point illustrated by the information presented in Figures 6 and 7 is that of access to control system documentation. In actual practice, it is often difficult to find current and accurate drawings for a conventional, built-up control system such as that illustrated in Figure 4. Data on setpoints, reset schedules, and event timing, such as that presented in Figure 6, are often even more difficult to find. In contrast, the "as-built" drawings for a DDC control system are always available in the form of the computer program code (Figure 7). In addition to the control logic, setpoint and other data are readily available. Program logic, setpoint and schedule data, and other information stored in a DDC unit can be displayed on a video terminal or printed when the control documentation needs to be examined or recorded.

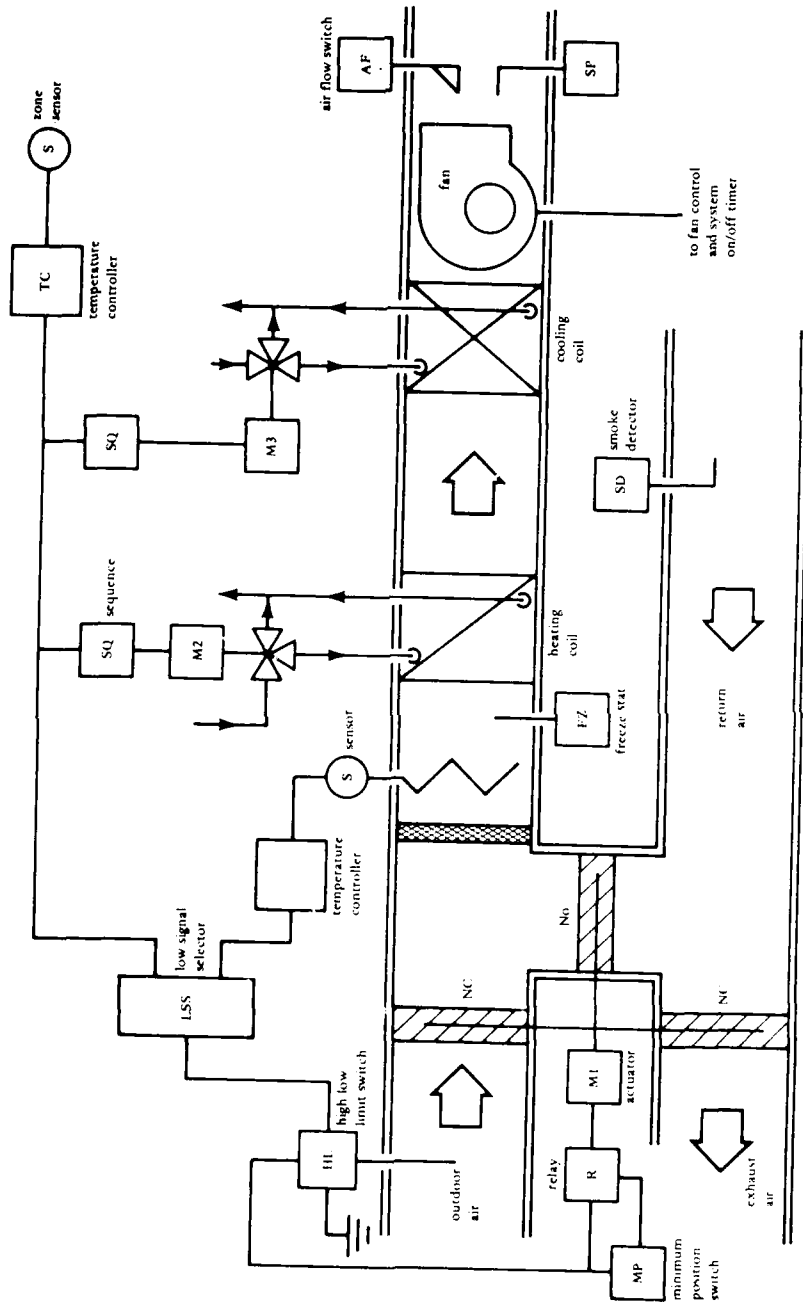

Figure 4 Single zone air handler with analog electronic controls

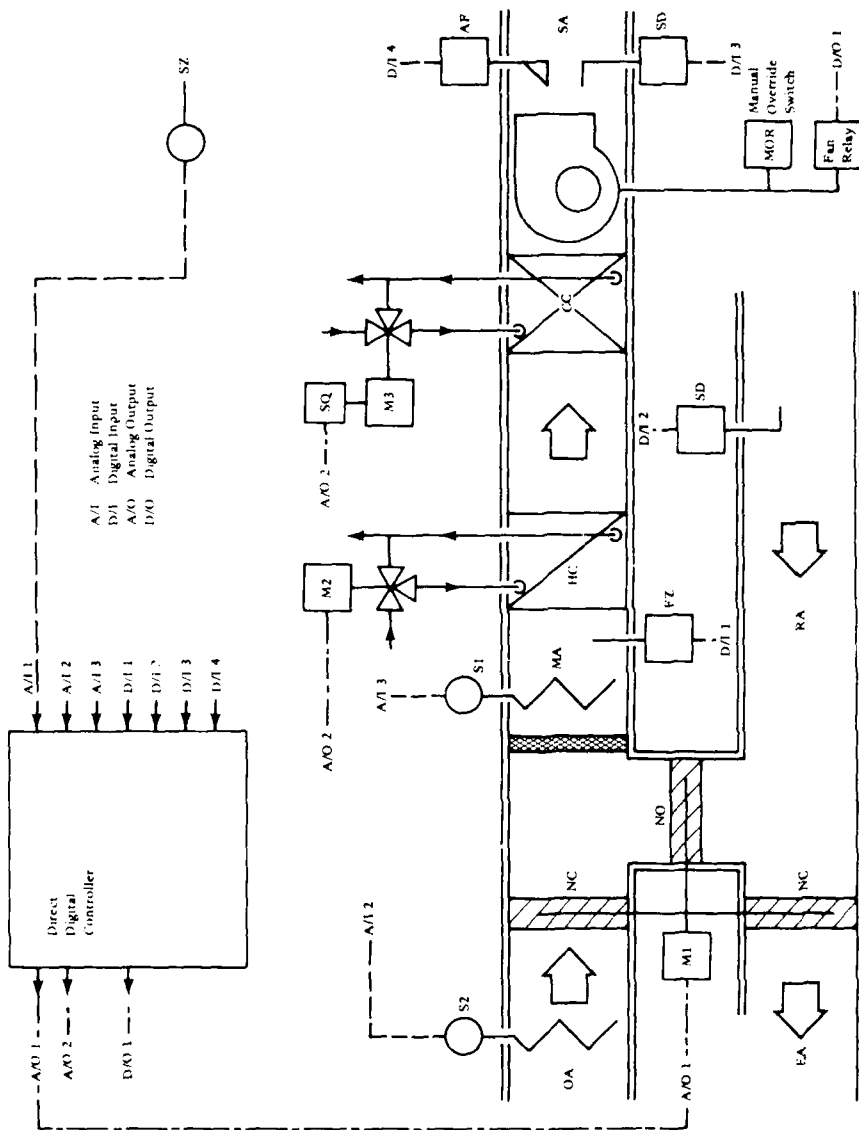

Figure 5 Single zone air handler with DDC

FAN CONTROL

The fan control circuit shall include safety controls, a hand-off-auto switch, timer energized controls, and a manual override switch.

Safety controls shall consist of an emergency disconnect switch mounted in the mechanical room, a manual reset freeze-stat, a supply air smoke detector, and a return air smoke detector.

With all safety controls closed and the hand-off-auto switch in the auto position, the fan shall be controlled by a seven day timer.

With the fan off, should the space temperature fall below 55°F, night thermostat shall restart the fan.

A manual override switch, located in the occupied space, shall, when activated, restart the fan for a timed period of 1 hour.

AC CONTROL AND TEMPERATURE CONTROL INTERLOCK

AC power and DC power to each component in the system shall be interrupted whenever the fan circuit is de-energized or there is no air flow as sensed by air flow switch, AF.

MIXED AIR SECTION

Mixed air sensor, SM, through controller, TCM, shall modulate the outside air and return air dampers to maintain a mixed air temperature of 60°F ±3°F.

With the system in the occupied mode, the minimum position switch, MP, shall insure the quantity of outside air is not less than 10% of the total CFM. When the system is in an operating but unoccupied mode, the minimum position switch shall be removed from the circuit.

High limit switch, HL, shall return the system to minimum outside air (occupied) or zero outside air (unoccupied) whenever the outside air rises above 70°F.

Figure 6. Sequence of control for pneumatic system.
(See Figure 4 for nomenclature.)

Whenever the zone requires less cooling than the mixed air section is providing, the discriminator, LSS, shall pass control of the OA/RA dampers to the zone controller.

HEATING COIL

Zone sensor, SZ, through controller, TCZ, and sequencer, SQ1, shall modulate the hot water valve from full heat to no heat over a zone temperature range of 66°F to 70°F.

COOLING COIL

Zone sensor, SZ, through controller, TCZ, and sequencer, SQ2, shall modulate the chilled water valve from no cooling to full cooling over a zone temperature range of 76°F to 80°F.

Figure 6. Continued.

Copy available to DTIC does not
 permit fully legible reproduction

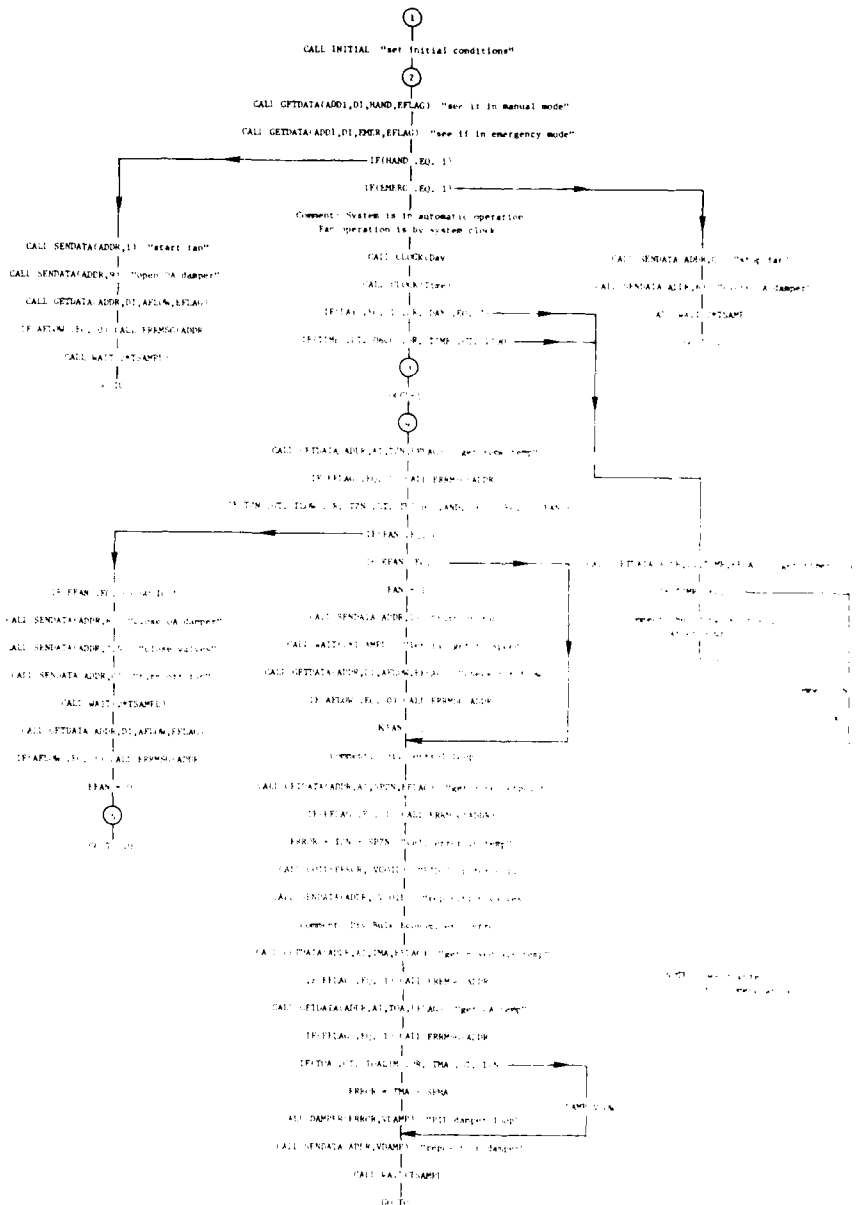

Figure 7. Control program flowchart for DDC System

Control system changes are much easier to implement with DDC than with conventional control systems. Changes to a DDC control system are made by changing the computer program and, perhaps, changing a sensor or actuator. Changes to a pneumatic or analog electronic control system usually require extensive rework of the control panel, including component replacement and re-wiring or repiping. This is because the control logic of a built-up control system, such as a pneumatic system, is composed of many discrete, special purpose devices with the logic "hard-wired in" by means of the interconnecting wire or pipes. This makes changing the system difficult and expensive. Figure 8 presents a typical control schematic for a small pneumatic system. Even this small system consists of more than 80 discrete components. It is often difficult to determine the control logic and operating sequence from control diagrams such as Figure 8. Also, the original "as-built" control schematic may no longer be very representative of the actual control system installation.

A significant advantage of direct digital control systems is the energy savings achievable through improved control of HVAC systems. Improved control is achieved in two ways: better feedback control algorithms, and more sophisticated control strategies.

A major advantage of DDC is the ease with which proportional-integral-derivative (PID) and other advanced control algorithms can be implemented. Most pneumatic and analog electronic controllers offer only proportional control. In proportional control, the output of the controller is made proportional to the difference between two inputs: one is the setpoint and the other is the measured variable. The problem with proportional control is that corrective action (i.e., an output from the controller) occurs only after

a measurable error occurs between the input and the setpoint. This results in loose control and a steady state offset error, or control droop. See Figure 9. Addition of integral control eliminates the offset error and improves control response. Integral control eliminates the steady state error by generating an output signal proportional to the accumulated error. In some control applications, it is important to consider not only the accumulated error, but also the rate at which the error signal is changing, or the derivative of the error. The addition of derivative control to the control program causes corrections to be made based on the rate to change of the error. Derivative control gives a controller a kind of "look ahead" or "feedforward" capability that is especially valuable when there are significant time delays between when an action takes place and when its effect is felt, for example when a temperature sensor controlling a damper is located in the ductwork many feet downstream from the damper. For most HVAC applications, PI control is an adequate control technique. A more detailed description of PID control is presented in Appendix A.

Figure 10 illustrates the performance of a system controller using PID control. Note the reduced settling time and the elimination of the offset error. PID control saves energy over proportional control because the offset error represents an unnecessary energy consumption (e.g. the cooling coil discharge temperature is lower than it would need to be with PID control). The faster settling time of PID control also results in reduced energy consumption and may result in improved occupant comfort.

Copy available to DTIC does not permit fully legible reproduction

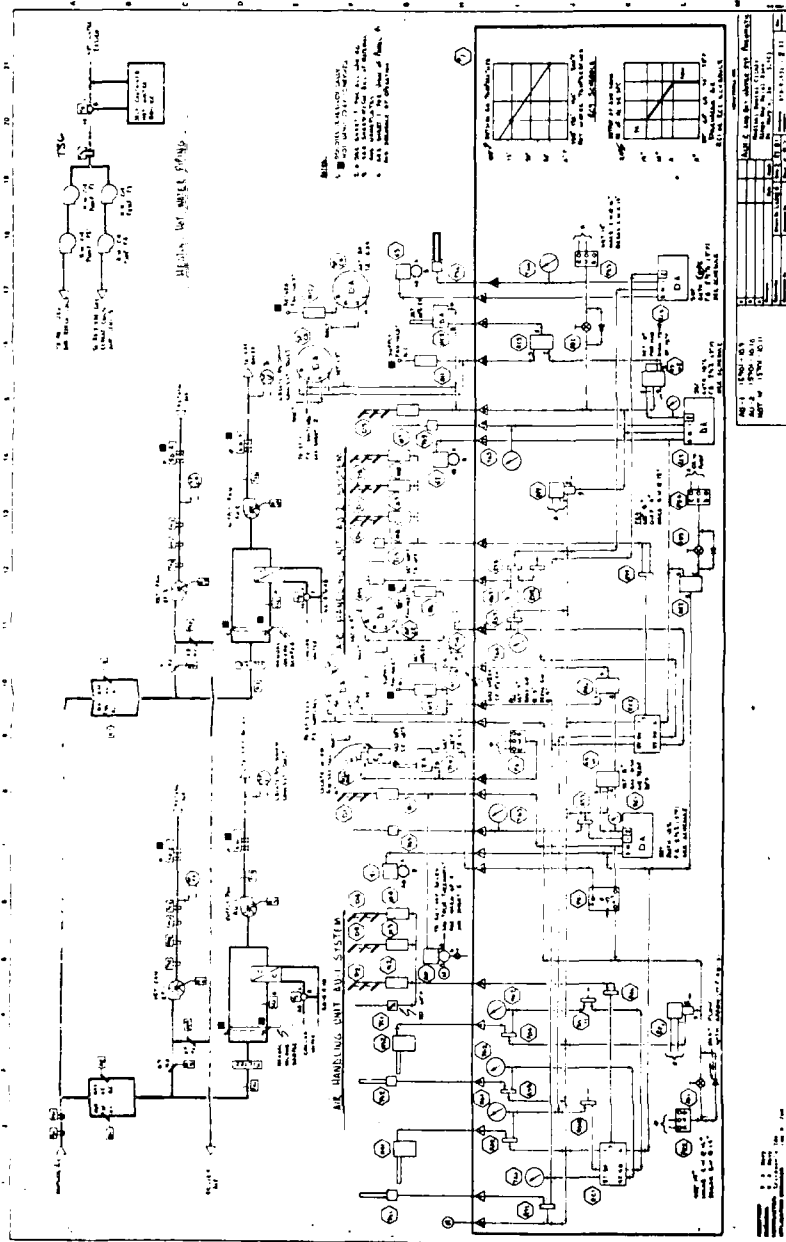

Figure 8 Schematic of a small VAV System with pneumatic controls

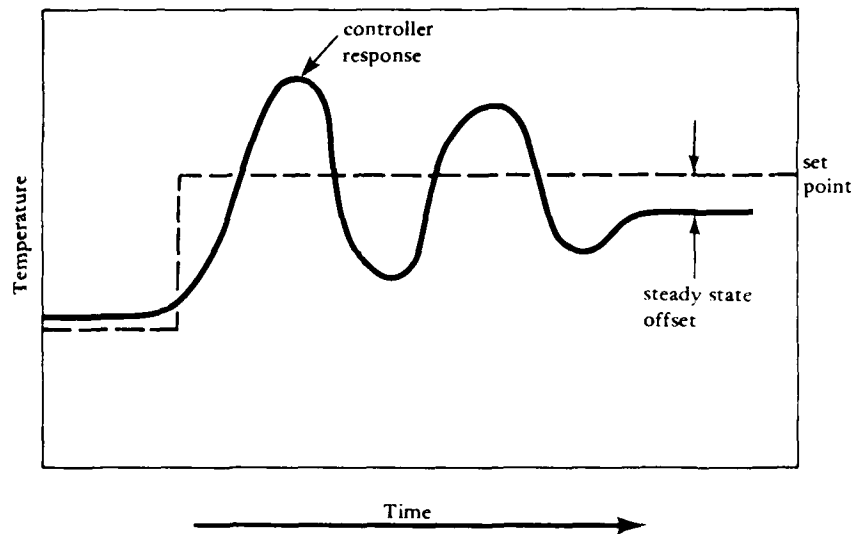

Figure 9. Proportional control.

PRECEDING PAGE BLANK-NOT FILMED

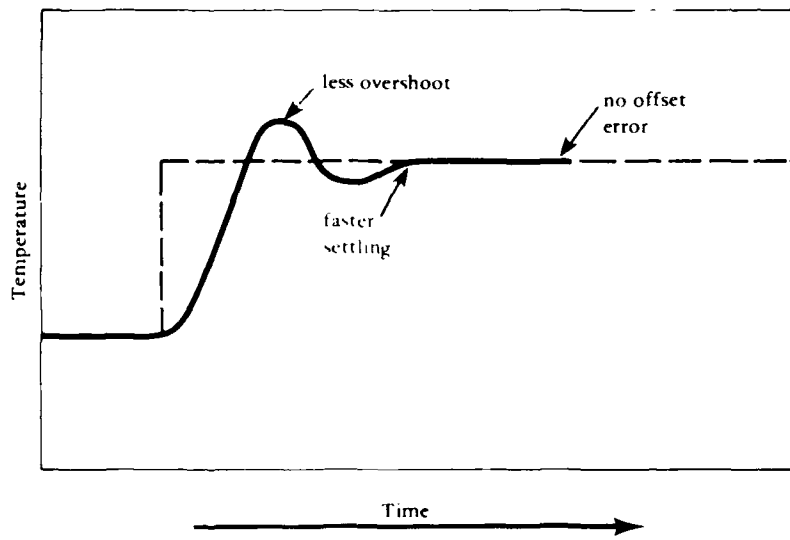

Figure 10. Proportional/integral/derivative control.

Figures 11 and 12 present data on measured control system response for a pneumatic and a direct digital control system operating under the same conditions. Note the improved performance achieved with DDC. Figure 13 presents the results of computer simulations which compare the energy costs for two types of HVAC systems, each with conventional proportional control and a DDC controller with a PID algorithm. Note that good control can save 10 to 15% of the energy cost associated with an HVAC system.

A very important feature of DDC is the ability to implement sophisticated energy management strategies, such as chiller or boiler optimization, enthalpy economizer cycles, load shedding, and optimum start-stop, with comparative ease. Many energy conservation strategies are difficult or impossible to implement with traditional control components or require purchase of specialized components.

Ease of operation is one of the major advantages of DDC control systems. Most control system manufacturers have tried to make their products "user friendly." Information on controller inputs, outputs, and setpoints is readily available by means of built-in or plug-in alphanumeric display terminals. With the proper access codes, setpoints and other controller parameters can be readily changed by engineering or maintenance personnel. Other access codes permit changes to be made in the computer program.

DDC control has been used in industry, especially the chemical, food, and other process industries for about the past 10 years. It has been proven to be very reliable, even in very harsh environments. As a consequence, it has virtually supplanted pneumatic control in these industries. When there is a problem with a microcomputer-based system such as DDC, the controller can often assist in problem diagnosis.

The operating system and support programs for a DDC controller can be written to perform many self-test and self-diagnosis functions. Controllers are available which can alert the user to bad sensors, faulty peripheral functions, and inoperative output devices.

Direct digital control devices further simplify the task of system maintenance by the fact that the parts count of the system is much lower than that of a comparable pneumatic or analog electronic control system. So the problems are easier to repair and the required inventory of spare parts is small.

Finally, DDC control systems facilitate the display of system data and alarm conditions, and are readily tied into EMCS systems if supervisory control or enhanced data acquisition and analysis capabilities are desired.

Direct digital control systems are not without disadvantages, however. One of the present disadvantages is the higher cost when compared to pneumatic and analog electronic systems. This is especially true for smaller size systems. The relationship between system cost and system size is illustrated in Figure 14. Because traditional control systems are assembled from a collection of discrete components, system cost tends to rise linearly with increasing system size. With a DDC system, however, a substantial investment is required for the components necessary to make even a single loop system work, but after that investment is made, the system can be inexpensively expanded to control many loops and provide other capabilities as well. Of course, the addition of accessories such as a color CRT operator console, remote communications capability, or data logging and trend analysis capability will add significantly to the cost. It is a fact, however, that the minimum competitive system size for DDC has been getting smaller as the

prices for these systems decline. A recent (1984) study of a demonstration installation of a DDC unit on a small (20,000 CFM) single zone air handler at the Pacific Missile Test Center, Point Mugu, CA., concluded that the hardware costs of a DDC system and a comparable pneumatic control system were \$4,300 and \$1,200, respectively. These estimates do not include the costs of pneumatic actuators and other components common to both systems. The cost of installing and maintaining the DDC system is expected to be lower than that of a pneumatic system, but no data on these costs are available at this time.

Another factor which has been acting as a restraint to the implementation of DDC is acceptance by building owners and operators. Most building operators are familiar primarily with conventional controls, usually pneumatic control as pneumatics comprise about 90% of all installed control systems. There is a natural reluctance to abandon a technology that is basically simple, mechanical in nature, easy to understand, and (in theory at least) easy to operate and maintain. This is especially true if the replacement technology appears to be complex or mysterious (as computer technology appears to be to many people) or if it seems that a great amount of training will be required to understand and operate the system. Training in the operation of DDC systems is offered primarily by the manufacturers of the equipment, as many features of a DDC system (including the programming language and problem diagnostic features) are unique to the manufacturer's product. However, more general courses on DDC and on HVAC system operation and maintenance are offered by a variety of organizations including trade organizations, vocational schools, and the extension services of universities. A high school education is adequate for basic understanding and operation of DDC systems for HVAC applications.

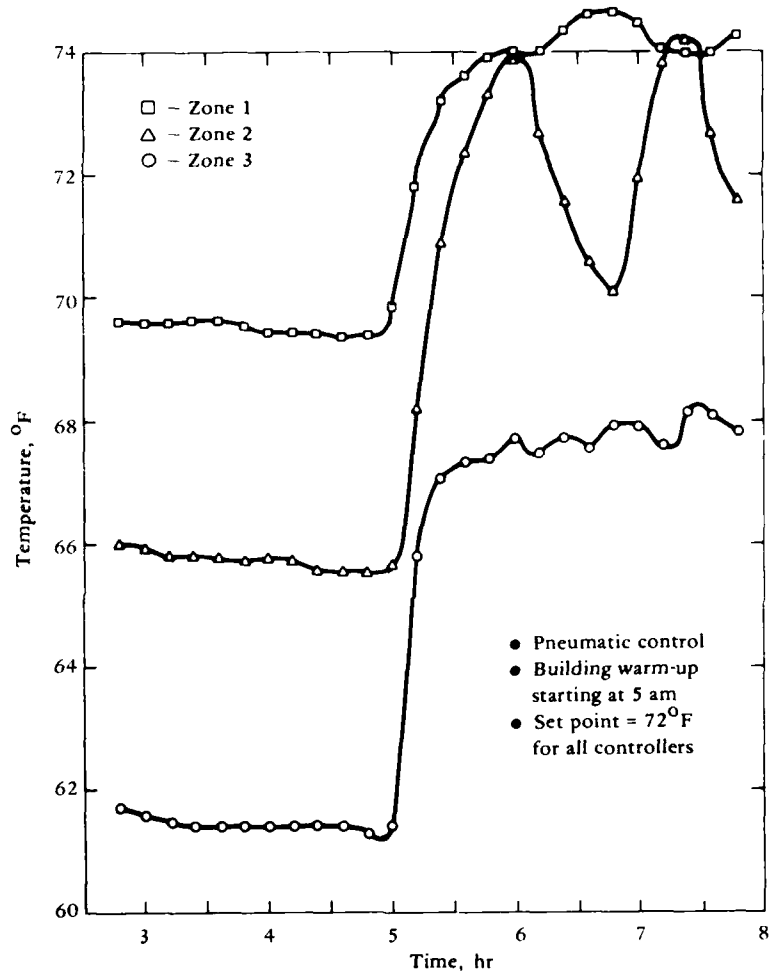

Figure 11. Measured system performance with pneumatic control. (Ref 1)

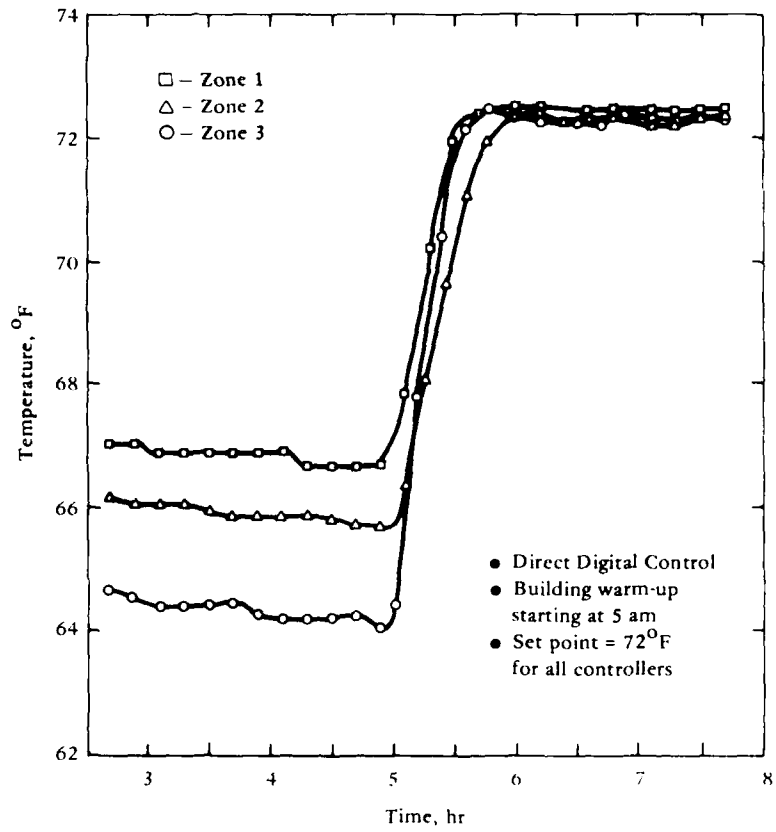

Figure 12. Measured system performance with Direct Digital Control. (Ref 1)

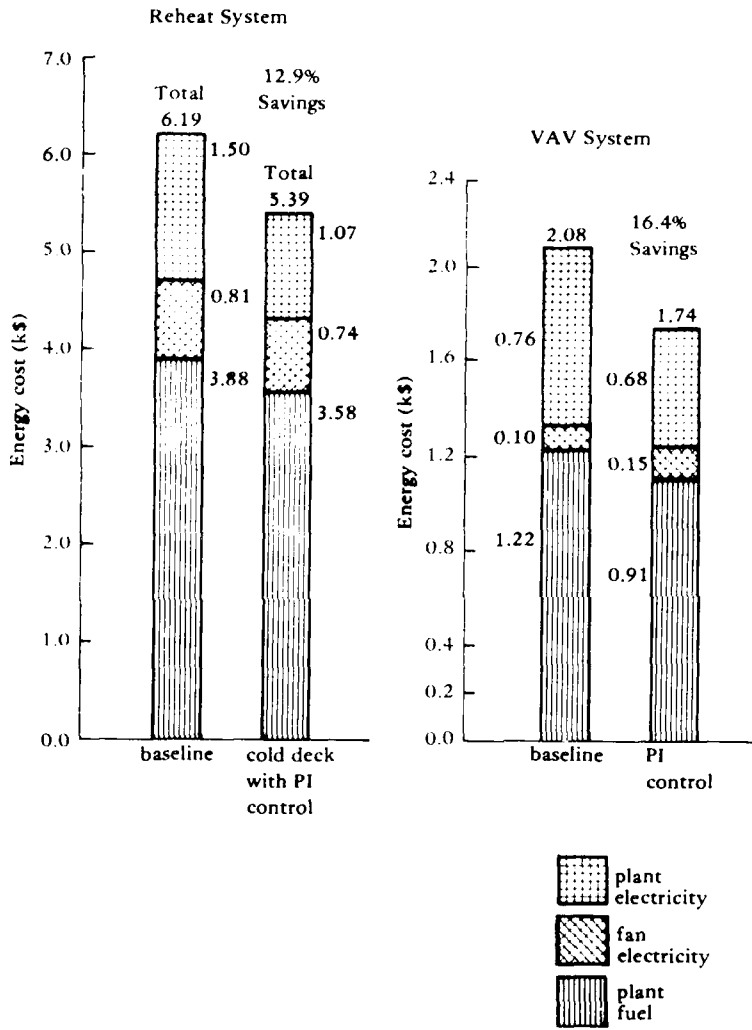

Figure 13. Comparison of energy consumption of two HVAC Systems with PI Control. (Ref 2)

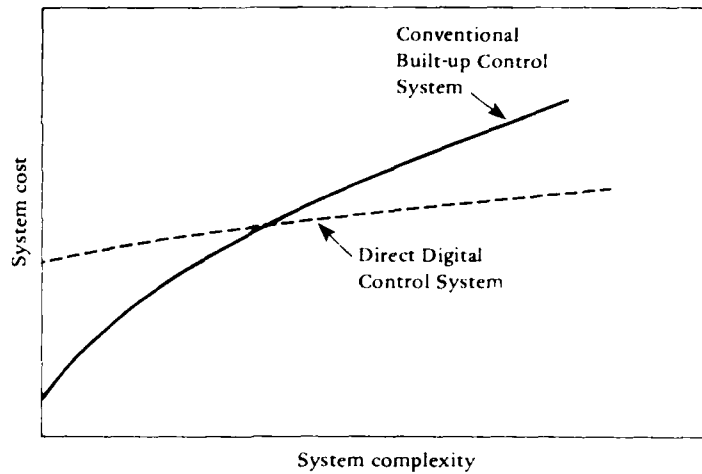

Figure 14. Relationships between control system size and cost.

What are the components of a DDC control system?

The microcomputer

The heart (or perhaps brain is a better term) of a DDC control device is a small digital computer, often referred to as the central processing unit or CPU. The CPU is usually contained on a single micro-circuit chip. The CPU performs arithmetic and logical operations on data (numbers) it reads from memory or input devices, then writes the result back to memory or to an output device. All computer-based devices must have memory, or data storage, capability. This memory is usually in two forms: read only memory (or ROM), and random access memory (or RAM). ROM is called inviolate memory because it not easily changed or lost, while RAM is the the part of the system memory which is constantly being modified. Data in RAM will be lost if power is removed from the circuit (unless it is provided with a backup battery power supply), while data in ROM will

not be affected. The type of ROM used in most controllers is called an electrically erasable programmable read only memory (or EEPROM). This type of memory permits the read only memory to be altered in the field by means of a controller programming device. Program instructions and data which will not be changed are stored in ROM, while input data, the intermediate results of calculations, and other variables are stored in RAM. Two special purpose integrated circuits are used to change analog data from sensors into a form the computer can use and to convert the results of the computer operations into analog, or continuous, form. An analog-to-digital converter (ADC) converts an input voltage into a digital form (usually an 8 or 12 bit binary number) that is compatible with the requirements of the CPU. A digital-to-analog converter performs just the opposite function, i.e., it converts a binary number into a voltage level, which can be used to operate an actuator, transducer, or other device.

In addition to the basic components listed above, a DDC controller usually contains other components such as an electronic clock to provide time-of-day and calendar functions, and a communications device so that the controller can "talk" to other controllers, computers, or data terminals.

The components of a typical DDC system are illustrated in Figure 15.

Sensors

The following types of sensors are commonly used in DDC systems for HVAC applications: temperature, humidity, pressure, flow, status, and position. All of the preferred types of sensors used in DDC control systems have an electrical output. The temperature sensors are usually one

of three types: thermistor, resistance-temperature devices (RTDs), or integrated-circuit temperature sensors. The preferred humidity sensor is the modern thin-film solid state device. Pressure sensors are usually based on a strain gage loaded by a diaphragm. There are many types of flow measuring devices on the market. Some flow sensors have an analog output (such as those which depend on measuring a pressure drop through the measuring device), while others have an output that is essentially digital in nature and consists of a series of pulses. Examples of flow meters having an analog output are an orifice and a venturi flow meter; flow meters having a digital output are turbine and vortex shedding meters. Status sensors are basically switches, and are used to signal the controller whether or not a device is on or off, open or closed, and so forth. It is sometimes valuable to have an independent measure of the position of final control elements, such as valves and dampers. This position feedback information can be provided to the DDC computer by a number of methods, one of the more reliable being to connect the valve stem or damper shaft to a linearly variable differential transformer (LVDT). An LVDT is a special purpose transformer which outputs a voltage proportional to the distance a metal plunger is moved within the core windings.

A detailed description of sensor technology for DDC and EMCS is presented in Reference 3.

In general, it is worthwhile to pay extra for accurate, calibrated, interchangeable sensors. The investment in an accurate control system will not pay off if it can not perform to its designed capabilities, and it cannot provide accurate, dependable control based on poor input data. Some specific recommendations on sensor selection are presented in Section IV - Applications. The question of sensor accuracy (and

cost) versus controller performance (and energy savings) is the subject of several current research projects, and quantified answers to this question should be available in the near future.

Actuators

Two types of actuator power are commonly used with DDC systems: pneumatic and electric. Because of their relatively low cost, actuating power, and high reliability, pneumatic actuators appear to be the preferred technology at the present time. Since the output signal from a DDC device is either an analog voltage level or a switch closure, some method is required to convert the electrical output to a branch line air pressure signal to operate the pneumatic actuator. The device which converts an analog voltage to a pressure level is called an electrical to pneumatic transducer or E/P transducer. Some DDC units have built-in E/P transducers, but on most units it is a separate hardware item. A pair of digital outputs can also be converted into a pressure level signal by using the output signals to activate an arrangement of solenoid valves. These interfacing techniques are discussed in detail in a later section of this document.

Electronically controlled electric actuators, such as those which have a shaft that rotates from rest to a certain position on the application of a signal from 3 to 9 volts (DC), can usually be connected directly to the analog output terminals (or ports) of the DDC controller.

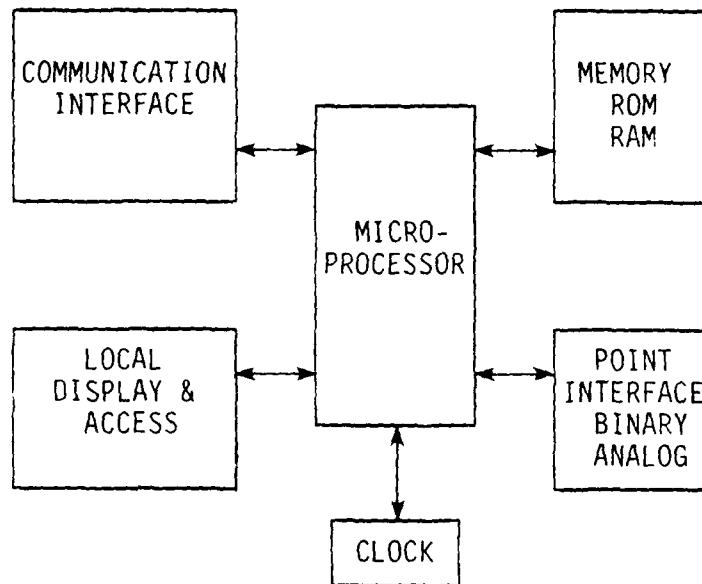

Figure 15. Digital controller hardware components.

Stepper motors are also used in some actuator applications, especially those in which a small motor can be used, such as control of a variable-air-volume (VAV) terminal. A stepper motor is a special purpose motor which rotates a fixed amount (often 7.5 degrees), either clockwise or counterclockwise, on each application of an electrical pulse. As a consequence, the amount and direction of rotation of the motor, and hence the position of the actuator, can be readily achieved through a series of program commands.

Connecting the parts together

Usually the sensors are connected to the controller by means of a simple shielded, twisted 2-wire pair. The input impedance of modern circuits is usually so high that current loop transmitters are not required for long distance signal transmission. Actuators are connected to the DDC unit by low voltage wiring or pneumatic tubing. In some parts of the country where lightning strikes are a problem, or in very noisy electrical environments, fiber optic technology may be used to connect sensors to the controller or connect the controller to other controllers or a central computer. In fiber optic "wiring," information is carried by light transmitted through a slender glass fiber rather than electricity. A third method of connecting sensors and actuators to the controller is by means of power line carrier (PLC) technology. PLC uses the same wiring which distributes electrical power through the building to carry coded messages between components of the system.

All of these communication systems will be discussed in detail later in this document.

IV. APPLICATIONS

Selection and Design Guidance

HVAC System Complexity and Appropriate Technology. As a general rule, DDC control system technology is cost effective only for relatively large and/or complex HVAC systems. The reason for this was discussed earlier and was illustrated in Figure 14. Traditional control systems are composed of whatever number of discrete components are required to do the job. Thus, the small control systems have a only a few parts and relatively low cost, and large control systems have many components and a higher cost. Because the traditional control system is assembled from discrete components, the cost tends to increase linearly with system size.

With DDC control systems, a certain minimum number of components must be included in even the controller regardless of the size or complexity of the HVAC system it controls. For example, a microcomputer, memory, A/D, D/A, power supply, and other components are required in a DDC device whether the device controls one actuator or ten. In fact, it costs little more to build a DDC system to control many devices as to control one or two. Thus, DDC controllers costs are characterized by a relatively high minimum cost and a comparatively small rate of change of cost with system size. The minimum size of HVAC system for which DDC is the most cost effective control technology is not a matter of component costs alone; differences in operating and maintenance costs, energy savings potential, and other factors also need to be considered. The minimum size HVAC system for cost effective application of DDC has been decreasing every year since the introduction of

DDC due to the decline in the cost of the electronic components, increased competition in the market, and the recovery of investment by manufacturers.

The cost effectiveness of a DDC system can sometime be improved by using DDC as part of a "hybrid" control system that mixes DDC and conventional control technology. For example, instead of applying DDC throughout a VAV or reheat HVAC system, it may be both technically acceptable and economically sound to use DDC to control major HVAC functions such as the mixed air sections, hot and cold deck temperature, fans, and chiller, and use pneumatic controllers for local applications such as VAV terminal or reheat coil control, where precise control has no significant benefits.

Direct digital control will probably never entirely replace pneumatic or self-powered control devices. For certain applications, such as firestats, freezestats, and other alarms, the independence and reliability of traditional control components will assure their continued use, at least as a backup to the DDC system.

Features to Look for in DDC

There are several features of DDC systems which should be evaluated by those considering installing DDC.

Programs. A DDC system should contain as standard equipment a selection of prewritten computer programs for standard controller functions such as time-of-day, economizer cycles, reset, load shedding, chiller optimization, VAV fan synchronization, and optimum start/stop. The prospective buyer of a DDC system should investigate the issue of prewritten programs carefully to determine exactly what is available

and how it works. It is helpful to obtain flowcharts or detailed narrative descriptions of the programs to aid in assessing whether or not they can do the anticipated job. Some HVAC control programs have been developed by the Government as standards against which vendor programs can be compared for performance. If a vendor has demonstrated that the performance of their HVAC control programs meets or exceeds that of the Government bench mark, the code is assured to be capable of acceptable performance. The existence of a large selection of prewritten control algorithms means that less custom programming will be required and, as a consequence, acquisition cost will be reduced. Special purpose programs can often be developed by connecting separate prewritten programs (or parts of programs, called subroutines) with custom programming. This technique substantially reduces program development costs.

Ease of Programming. It is always necessary to do some custom program development because every HVAC installation is unique. Most DDC vendors offer a programming service which will do the program development work based on the customer's system schematics and a narrative description of the control system operation. If the customer is interested in doing its own program development, it should investigate the programming language used by the vendor for ease and flexibility in programming. The class of programming languages termed "high level" languages, such as BASIC and FORTRAN, are the easiest to learn and to use because the commands are written in English language-like statements. At the other end of the language spectrum are the assembly languages, machine codes, and other device specific languages by which the electronic components actually communicate with each other.

Programming in these fundamental languages requires substantially more training and is much more time consuming. Most controller programming languages offered by manufacturers of DDC equipment fall somewhere between a true "high level" language and a machine level language, although the trend is toward use of a high level language such as BASIC or PASCAL.

Diagnostics and Data Display. An important feature to look for in a DDC system is a large number of self diagnostic features. Self diagnostics help take some of the mystery out of "computerized" control systems and aid in revealing and correcting problems with both the system hardware and software. For example, a DDC system can be easily programmed to detect open circuit or short circuit sensor or actuator wiring, sensors which are giving suspicious readings, or actuators that fail to respond to controller output. The self diagnostic feature can also be used to identify possible problems in the control program, or software. A data search procedure that fails to find the required value, an iterative calculation that does not converge to a solution, calculated values which are outside the range of expected values are all examples of possible problems with the program code that can be identified with the aid of adequate diagnostic messages. The ability to display current and historical values of temperature, humidity, pressure or other properties of the HVAC system will aid in understanding how the HVAC system is performing and can lead to increased energy conservation, lower operating costs, and improved maintenance.

Reliability. The reliability of DDC controllers should, in theory, exceed that of traditional built-up control systems because of the

smaller number of components in the control system. If the circuit boards and other components of a DDC system are selected by the manufacturer with care and assembled with a high level of quality control, very high reliability rates can be achieved. Also, the working parts of the controller cannot be made inoperative by dirt, oil, or water in the working medium as can pneumatic devices. Care must be taken, however, to protect the DDC system from excessive voltages and spurious signals. Adequate lightning protection and shielding of signal lines are required in many DDC installations.

Overall system reliability is also improved by constructing the control system from many independently operating controllers rather than one central controller. This system design is called distributed control or distributed processing.

Data on the reliability of the DDC systems offered by different manufacturers are not available at this time, so it is suggested that the prospective purchaser of a DDC control system obtain the names of previous customers from the vendor and contact them to obtain first hand information on the performance of the DDC unit being considered.

Maintenance and Service Support. The maintenance requirements of a DDC control unit will be less than those of conventional control systems for several reasons. First, there are fewer parts to break. When something does need repair, the problem should be easier to isolate. (This is particularly true if the computer portion of the controller has remained operative, as the computer can often be used to help find the problem.) Repair is generally by replacement of the defective circuit board, relay, sensor, or other component. Because of the comparatively

small number of parts in a DDC system, the inventory of spare parts will be much smaller than that required for a conventional control system. Also, because of the digital nature of controller operation, the control system will not "drift" over a period of time as do both pneumatic and analog electronic systems. Once initial set-up and calibration have been performed on a DDC system, the output will remain consistent with the input.

Digital devices such as a DDC controller tend either to work as designed or to not work at all. Digital circuits, if correctly designed, are more immune to noisy or unpredictable operation than are most analog circuits. If control action appears to be changing in an unexplainable manner, check the inputs - the problem is often a bad sensor or wiring.

The quality of support you receive from the local DDC supplier and the manufacturer is an important factor in determining the ease with which DDC can be implemented at your facility and the degree of satisfaction you will have with it. Check the history and qualifications of the manufacturer in detail and visit local installations of their products. A great deal can be learned by spending an hour talking with past customers.

Interfacing with DDC. A DDC system must interface (or "talk") to at least three external entities: the input devices, the output devices, and the operator. Sometimes a fourth device, another computer, is added to the above list.

Interfacing sensors

Temperature sensors. The two types of temperature sensors most commonly used in DDC systems are resistance temperature devices, or RTDs

and thermistors. The electrical resistance of a metal at some temperature T may be related to its resistance at some reference temperature R by the equation:

$$R_T \cong R_0 (1 + \alpha T), \text{ ohms}$$

If the coefficient of resistance (α) is high, this property can be used to accurately measure temperature. One of the metals most widely used in the manufacture of resistance thermometers is Platinum, which is formed into a very thin wire arranged in a serpentine pattern similar to a resistance strain gage and housed in a protective sheath. Balco alloy is another metal which is often used in the manufacture of RTD temperature sensors. RTDs have a positive temperature coefficient, which means that resistance increases with increasing temperature (see Figure 16).

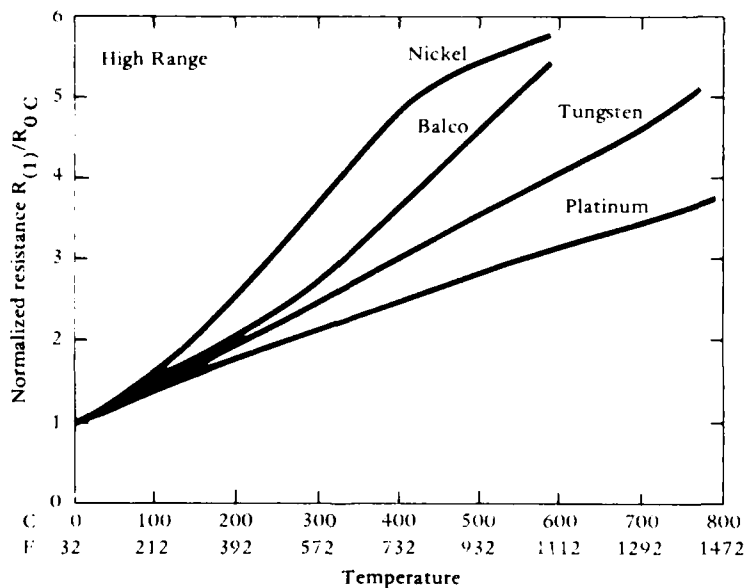

Figure 16. Resistance/temperature relationship for several metals. (Ref 4)

Another commonly used kind of electrical resistance temperature measuring device is the thermistor. A thermistor is made by sintering oxides of metals, such as manganese, nickel and cobalt, into a very small bead, then coating the bead with resin or glass for protection. The small size of thermistors makes them very sensitive and rapid in response. The resistance of thermistors decreases with increasing temperature and is exponential in form as opposed to the almost linear characteristic of RTDs. This characteristic of thermistors makes signal conditioning somewhat more difficult than it is for a linear device. Another disadvantage of thermistors is that they are not readily interchangeable and tend to drift with age. Thus, a thermistor temperature sensor needs to be periodically recalibrated to assure accurate measurement.

The characteristics of commonly used temperature sensors are presented in Table 1. The preferred temperature sensor is the 1000-ohm Platinum RTD.

A Wheatstone bridge resistance network (Figure 17) is usually used to measure the unknown resistance of the sensor and, hence, the temperature. The main factor affecting the accuracy of the measurement is the the unknown changes that take place in the resistance of the sensor leads. This is particularly true when the sensor is located some distance from the bridge network. To compensate for lead wire resistance, the preferred RTD design has two built-in compensating resistors which are an integral part of the RTD unit. This compensating RTD is called a four-wire resistance temperature device (Figure 18). When a four-wire RTD is used as the sensor, any changes in lead resistance also take place in the "dummy" leads, and, since each set of leads is in opposing legs of the bridge network, these changes are

completely balanced out. The analog input terminals of most DDC controllers are connected to Wheatstone bridge circuits built into the controller circuit.

An alternative approach is to use a two-wire RTD bridge located very close to the sensor to minimize the influence of lead length, and then convert the resulting voltage difference into a current signal for transmission to the controller. The device which converts a potential difference (or voltage) into an electrical current is called a current loop transmitter. The standard current loop transmitter provides an output which ranges from 4 to 20 milliamperes, full scale. By connecting a resistor across the output of the transmitter at the "receiver" end, the current signal is converted back into a voltage. A precision 250-ohm resistor converts a 4-20 mA signal into a 1 to 5 volt potential difference (see Figure 19). The reason current loop transmitters are used is that although the voltage difference will vary between a pair of wires along their length, the current flowing in the wires will not; thus electrical current is an unambiguous carrier of information.

A third way to transmit the sensed information to the DDC controller is digitally, i.e., as a series of 1's and 0's or, equivalently, as a series of high and low voltage pulses. To transmit information digitally, the analog-to-digital convertor must be located at the sensor (vice at the DDC unit) and digital information converted from parallel format into serial format. Additional circuitry controls the timing of the data transmission from the sensor unit. The data wires are connected to a digital input port of the DDC controller rather than an analog port. The digital transmitter unit may also contain an additional micro-circuit which functions as an addressable send/receive unit. This permits all

of the sensors to be connected in a single loop of field wiring as illustrated in Figure 20. This loop, or network, also carries the electrical current which powers the individual sensor/transmitter units. In operation, the DDC controller is programmed to send a series of binary digits (or bits) over the loop. This series of bits contains information on which sensor the controller wants to communicate with (i.e. a device address) and an instruction to the sensor unit. For example, the DDC controller might address a particular temperature sensor and request that the data from that sensor be transmitted back to the DDC controller. The sensor would then respond by sending a digitally coded value of temperature to the controller. In this manner, all of the sensing devices can be "polled," or accessed. Because the data are transmitted as digits, the data are less susceptible to electrical noise. Also, error check codes can be used in the DDC program to estimate the accuracy of transmission of the data.

A control computer can also communicate with remotely located sensors or actuators over the same wires used to distribute electrical power throughout the building by means of a method commonly called power line carrier or PLC. The PLC method is much like the method described in the preceding paragraph except that the 120 VAC power wiring is used to interconnect the system components. Instead of turning the current on and off to encode a message as the dedicated line method does, the PLC method modulates a special carrier frequency placed on the power circuit. The carrier frequency is selected such that it will not interfere with the operation of other devices on the circuit, such as motors or clocks. Obviously, to use the PLC method, the controller sensors and actuators must be connected to the same electrical power circuit.

Table 1. Temperature Sensor Characteristics (Reference 4)

Evaluation Criteria	Platinum RTD 100% Wire Wound and Thin Film	Platinum RTD 1,000% Thin Film	Nickel RTD 1,000% Wire Wound	Balco RTD 2,000% Wire Wound	Thermistor	Thermocouple	Semiconductor Devices
Cost	High	Low	Medium	Medium	Low	Low	Low
Temperature Range	Wide -400 to +1,200°F	Wide -320 to +1,000°F	Medium -350 to +600°F	Short -100 to +400°F	Short to Medium -100 to +500°F	Very Wide -450 to -4,200°F	Short -57 to -257°F
Interchangeability	Excellent	Excellent	Fair	Fair	Poor to Fair	Good	Fair
Long Term Stability	Good	Good	Fair	Fair	Poor to Fair	Poor to Fair	Good to Fair
Accuracy	High	High	Medium	Low	Medium	Medium	Medium
Repeatability	Excellent	Excellent	Good	Fair	Fair to Good	Poor to Fair	Good
Output Voltage	Medium	High	High	Very High	Very High	Low	High
Response Time	Medium	Medium to Fast	Medium	Medium	Medium to Fast	Medium to Fast	Medium to Fast
Linearity	Good	Good	Fair	Fair	Poor	Fair	Good
Lead Length Effect	Medium	Low	Low	Low	Very Low	High	Low
Physical Size	Medium to Small	Small to Large	Large	Large	Small to Medium	Small to Large	Small to Medium

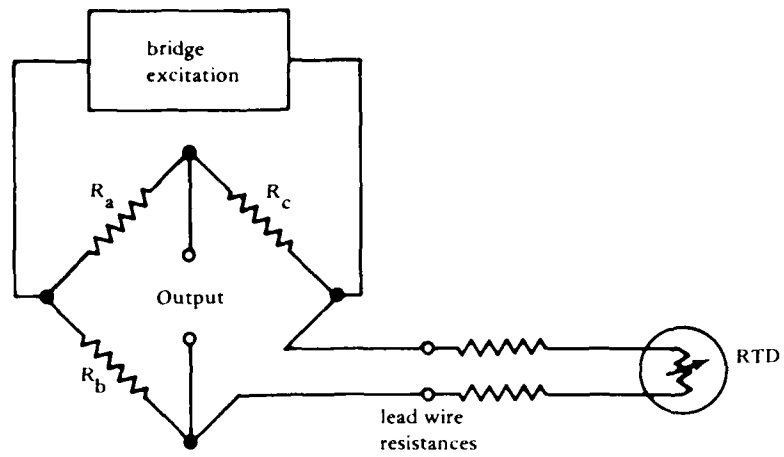

Figure 17. Two wire RTD sensor and bridge circuit.

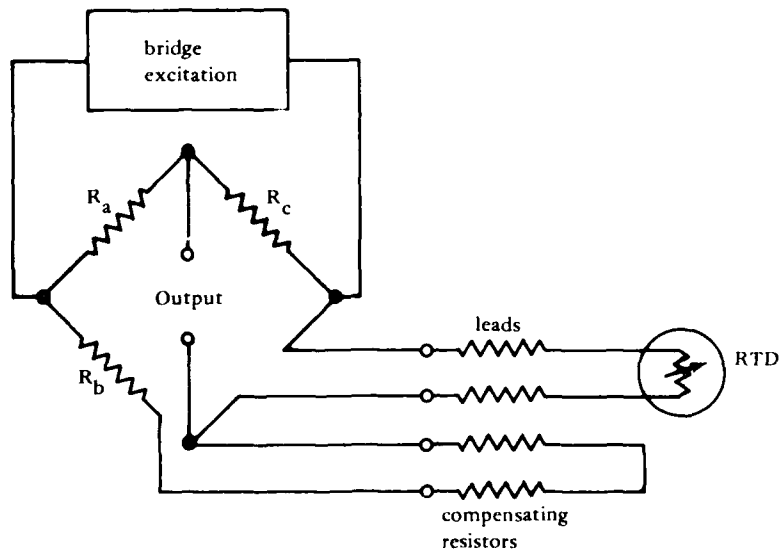

Figure 18. Four wire RTD sensor and bridge circuit.

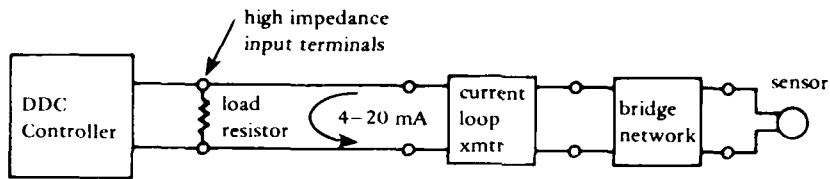

Figure 19. Current loop transmitter.

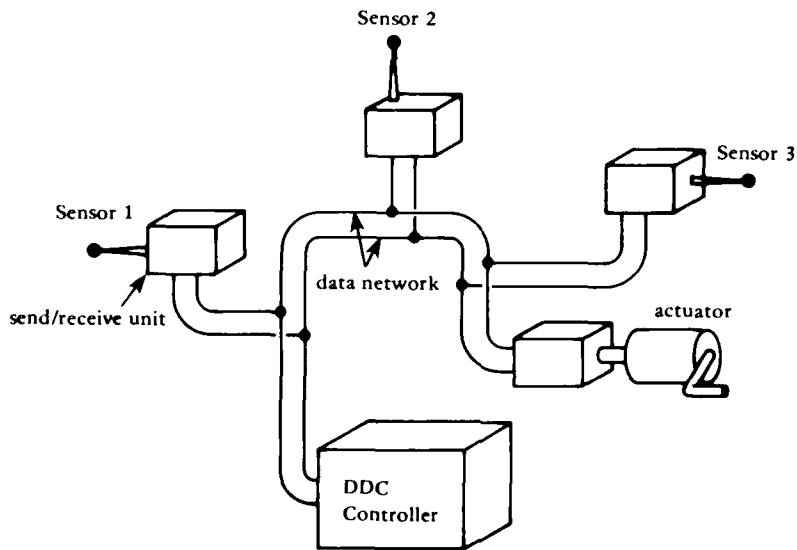

Figure 20. Digital data network.

Humidity sensors. There are many methods in use to measure the moisture content of air (see Table 2). One of the most modern and accurate methods is based on the change in capacitance in a thin film polymer capacitor as it absorbs water vapor. This type of sensor is reported to permit measurement of high humidity over long periods of time with high accuracy. The device is also claimed to be stable and linear throughout the range of 0 to 100 percent relative humidity. Changes in capacitance can be measured by an alternating current bridge circuit called a Schering bridge which is similar in principle to the DC Wheatstone bridge, or by a single ratio transformer bridge. The necessary detection and bridge circuitry for humidity sensors are usually packaged as part of a "humidity transmitter" which has as output a 4-20 mA signal proportional to relative humidity.

A second popular type of humidity sensing device uses a sulfonated polystyrene ion exchange membrane which changes electrical resistance with changes in relative humidity. Changes in resistance can be measured with a conventional DC bridge circuit.

Perhaps the most commonly used humidity sensor in HVAC applications is the lithium chloride dew point indicator, commonly called a dewcell. A dewcell works as follows: A solution of lithium chloride is heated by a small electric element until the water vapor pressure above the surface of the solution is in equilibrium with the water vapor pressure in the ambient air. It can be determined when equilibrium conditions are obtained because under equilibrium conditions, the current supplied to the heating element will be constant or the electrical resistance of the solution will not change with time. The equilibrium vapor pressure above a saturated solution

of lithium chloride is a known function of temperature. Thus, when the salt solution is in equilibrium with the air, the vapor pressure of the air becomes a known function of temperature. By measuring the temperature of the salt solution, the vapor pressure of the water in the air can be determined. Dew point temperature can be determined once the partial pressure of the water vapor is known. If the temperature of the ambient air is also measured, the relative humidity can be determined. Dew point sensors are often used in economizer systems to control condensation of water vapor inside of a building.

In general, relative humidity and dew point sensors consist of two parts: a replaceable sensor element and a transmitter unit. The transmitters usually have an output of 0 to +5 VDC, 0 to +10 VDC, or 4 to 20 mA.

The recommended humidity sensor is the thin-film capacitive type.

Pressure sensors. Pressure sensors are used in HVAC systems in several applications, the most common being the control of duct pressure in variable air volume (VAV) systems. The common design of pressure sensor is based on a strain gage loaded by a diaphragm. The pressure to be measured is applied to one side of a diaphragm, and the reference pressure is applied to the other side. The deflection of the diaphragm is measured by a resistance strain gage. Solid state piezoresistive devices are also used measure the deflection of the diaphragm. The change in resistance of the strain gage is measured by a bridge circuit similar to those used with RTDs. The output of the bridge circuit is often converted to a 0 to 10 VDC or a 4 to 20 mA signal for compatibility with other sensors.

In general, it is desirable to select pressure sensors having a comparatively large diaphragm (for increased sensitivity) and built-in protection against overloading the diaphragm and strain gage. Filters should be placed in the fluid lines connected to the sensor input ports to prevent dirt and other contaminants from entering the sensor.

Flow sensors. Although flow sensors are widely used in energy monitoring and control systems, they are not usually required for control of an HVAC system and will not be addressed in detail. Detailed information can be found in Reference 6.

The types of flow sensors usually found in an HVAC system seem to be divided into two basic categories: those based on a change in pressure through the measuring device (such as an orifice or venturi) and those based on counting some quantity which varies with flow rate (such as revolutions of a turbine wheel or the number of vortices shed per unit of time). Flow sensors based on measuring pressure change usually use the same pressure measurement techniques described above. If the flow sensor output consists of a series of pulses, those pulses can be counted by the computer and the flow rate determined.

Status sensors. A status sensor is simply a switch used to input on-off type information into the DDC computer. For example, a paddle switch might be used to provide a positive indication of flow, a smoke alarm to indicate the presence of smoke in the ducts, and a freezestat to indicate low outdoor air temperature. Usually, the only signal conditioning required for switch closures is that they be "debounced," which means filtering out the noise and other extraneous signals that occur at the instant of switch closure so as to provide the computer with an unambiguous signal.

Table 2. Sensor Properties (Reference 5)

Type	Method of Operation	Approximate Range	Approximate ^a Uncertainty	Response Time	Primary Output Parameter
Psychrometer, sling or aspirated	Measurement of water temperature due to evaporation	10-100% RH	3% RH	Medium	Temperature
Dew and frost point (chilled mirror)	Measure temperature at which dew or frost forms	-100 to +200°F (dew or frost point temperature)	4 to 0.4°F (dew or frost point temperature)	Medium-Fast	Temperature
Dewcell (LiCl sensor)	Measurement of equilibrium temperature of saturated salt solution	-20 to +160°F (dew or frost point temperature) (depends on ambient temperature)	3°F (dew or frost point temperature)	Medium	Temperature
Dummore	Measurement of resistance of aqueous LiCl in binder	7-98% RH	1.5% RH	Fast	Resistance
Jason	Measurement of reactance of Al_2O_3	25-85% RH	5% RH (increasing slowly to 10% RH from 32 to -40°F)	Fast	Resistance
Ion Exchange	Measurement of resistance of ion exchange resin	10-100% RH	Same as Jason	Fast	Resistance
Carbon	Measurement of resistance of a dimensionally-variable carbon impregnated film	10-100% RH	Same as Jason	Fast	Resistance
Dielectric crystal	Measurement of frequency change of quartz crystal covered with moisture film	-108 to 77°F (dew or frost point temperature)	5% of range (for frost points from -67 to -4°F)	Medium	Frequency
Color change	Color change of salts amount of dissolved moisture	10-80% RH	10-20% RH	Slow-Medium	Color
Mechanical	Dimensional changes of natural and synthetic fibers	10-90% RH	±5% at best	Slow-Medium	Dial reading
Thin film polymer	Measurement of frequency change of multivibrator as polymer absorbs and releases water vapor (change in dielectric constant or C)	0-80% RH 80-100% RH	2% RH 3% RH	Medium-Fast	Frequency

^a Assumes instruments have been calibrated to remove most systematic errors. Values listed are for state-of-art measurement.

Interfacing Actuators

Pneumatic actuators. Because of their relatively low cost, high power output, and proven reliability, pneumatic actuators are often the preferred controller device in an HVAC system. There are two basic methods of interfacing a pneumatic actuator with a DDC system: an analog electric to pneumatic transducer (or E/P for voltage to pressure transducer), or modulation of the branch line air pressure by means of digital signals.

The most widely used method of connecting a DDC output to a pneumatic device is the voltage-to-pressure transducer. In general, an E/P transducer consists of a small, flapper type bleed valve which is positioned by a solenoid (Figure 21). As the voltage across the solenoid is increased, the bleed port is closed and the pressure in the branch line to the actuator is increased. Thus, for example, a 0 to 5 VDC output from the controller is transformed to a 3 to 13 psi branch line pressure. Features to look for in E/P transducers include linearity between input and output, repeatability (output consistently follows the input), low hysteresis (output is the same on decreasing input signal as it is on an increasing signal), immunity to vibrations, and low power consumption.

The branch line pressure can also be controlled by using several digital methods. The branch line pressure can be controlled by means of a pressure regulating valve driven by a bi-directional motor or a stepper motor. This method is comparatively expensive, however, and offers no distinct advantage over other methods.

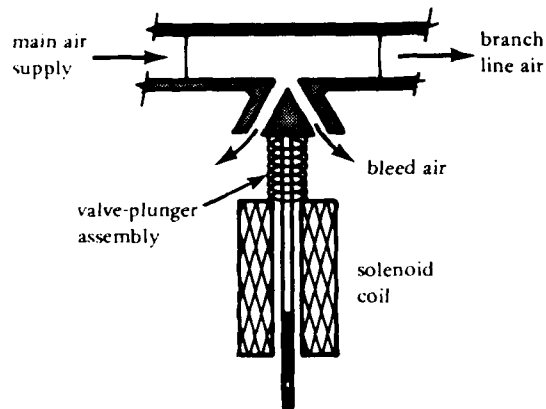

Figure 21. Schematic of electric to pneumatic transducer.

A digital control method which is mechanically simple and low in cost is illustrated in Figure 22. With this method, the branch line pressure is regulated by connecting it to the main air supply or to the atmosphere via simple solenoid valves as required to change the branch line pressure to the desired value. This method requires only two digital output ports for implementation: one to raise the branch line pressure and one to lower it. By varying the sequence and duration of supply and bleed valve actuation, the desired branch line pressure can be obtained. The restriction keeps the air flow through the control circuit to a low value, while the small tank provides the "capacitance" necessary for smooth operation and provides a way to accommodate small air leaks in the actuator circuit. The ratio relay is a standard pneumatic device used as a "volume amplifier" to increase the air flow to the pneumatic actuators. This interface technique is susceptible to errors from several sources, however, and the computer coding to make it work correctly can be extensive. See Reference 7 for additional details.

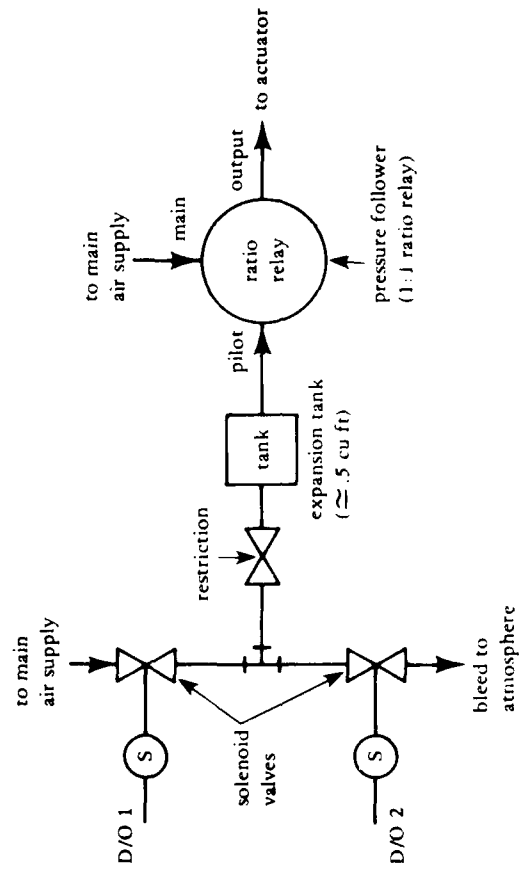

Figure 22. Schematic of digital to pneumatic transducer.

Figure 23 illustrates the supply air temperature coming off a chilled water coil controlled with the digital-to-pneumatic method shown in Figure 22. The computer program, or algorithm, used for this experiment was the PI version of the incremental PID algorithm described in Appendix A. Figure 24 presents experimental results for a different value of proportional gain. Figure 24 is presented to illustrate the sensitivity of system response to the choice of values for controller gains, i.e., the importance of good control system tuning.

At the present time, there is no true digital to pneumatic (D/P) convertor on the market, although several manufacturers are studying the design and market for such a device. The major problems are a lack of agreement on a standard for digital transmission of data with the HVAC controls industry, comparatively high cost, and a weak market for such a device.

The recommended approach is to use an analog output from the DDC device as input to an electric-to-pneumatic convertor.

Electric actuators. Most modern electric actuators used in HVAC systems have a control signal level that is compatible with the analog output of a DDC system. For example, a 24 volt motor may have a control circuit which puts the motor shaft in full counterclockwise position for a control input of 3 VDC, and which puts the shaft in full clockwise position for an input of 9 VDC. The actuator control terminals can usually be connected directly to an analog output terminal of the DDC unit. Actuator positioning is done by simply setting the analog output voltage to the desired value, e.g., 6 volts for a half open actuator. The major disadvantage of electric actuators is their comparatively higher cost.

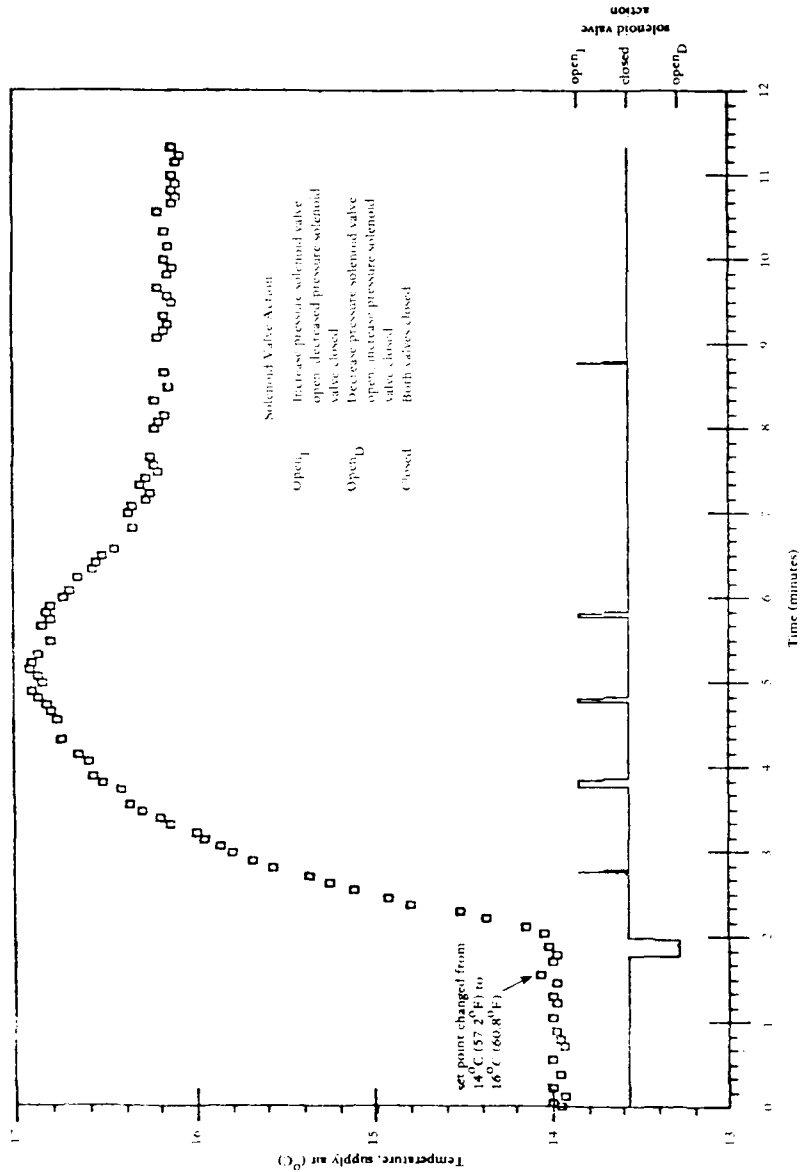

Figure 23 Plot of supply air temperature versus time using solenoid air valves controlled by PI algorithm with $K_p = 0.05$ and $t_i = 60$ seconds. (From Ref 7)

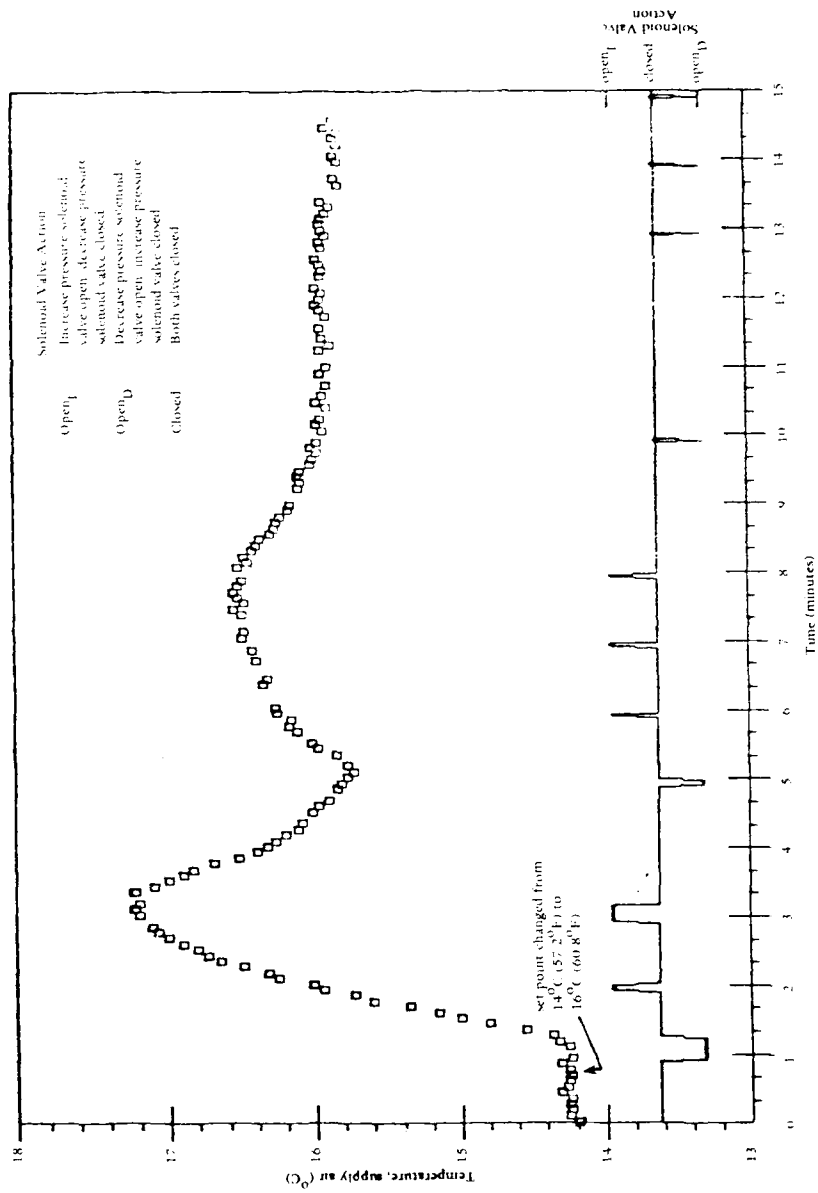

Figure 24 Plot of supply air temperature versus time using solenoid air valves controlled by PI algorithm with $K_p = 0.10$ and $T_I = 60$ seconds (from Ref 7)

Note: The analog output device should be capable of sourcing at least 100 mA so that it can drive distant actuators. Some digital-to-analog convertors may need to be followed by a small power amplifier circuit to drive the actuators of choice.

Contact Closures

Certain low voltage, low power devices such as annunciator lamps, can be powered from a digital output of the DDC unit, but in most cases a digital output is used to activate an electromagnetic or solid-state relay to permit the unit to control higher power devices such as a fan motor. Digital outputs (and inputs) of the controller should be electrically isolated from the rest of the control system. This is usually accomplished with a solid-state device called an "opto-isolator" which consists of a light emitting diode located very close to a light sensitive transistor and packaged as a single device. Isolation helps protect the DDC unit from inputs which would damage the controller circuitry.

Interfacing with Another Computer

Two decisions must be made before the DDC unit can communicate with another computer: what language will be spoken and in what form will the information be transmitted. There are several communication codes in use for information exchange, but the most widely used is the American Standard Code for Information Interchange (or ASCII). In this code, every eight-bit sequence of binary digits has been assigned a meaning, such as a letter of the alphabet, a decimal digit, or a punctuation mark. Thus, any message can be transmitted by sending the correct sequence of 8-bit groupings. The second question is whether

to send all 8 bits at one time over 8 separate wires or to send the digits out serially, one bit at a time, over a single wire and reassemble the word at the receiving end. The first method is called parallel data transmission and the second method is called serial data transmission. Although parallel transmission is very fast, it requires multiconductor cable and is not amenable to use over very long distances. Serial data transmission is the method most commonly used to interconnect computers. Specially designed circuits make the task of parallel-to-serial conversion and required conversion back to the parallel form easy to accomplish. These circuits are part of the computer interface card if you purchase that option. For communication of long distances, a device called a modem (for modulator-demodulator) is used. A modem converts the serial bit stream from the communications board of a DDC unit into a series of audible tones for transmission over telephone lines. A second modem at the receiving end converts the sequence of tones back into a serial bit stream for processing by the second computer.

Installation Guidance

As with any other type of control system, the sensors should be located where they will provide a true measure of the quantity being sensed. Temperature sensors for liquids should be mounted in an oil bath in a thermowell for accurate readings and ease of replacement. Air temperature sensors should also be located with care. Often it is appropriate to use a long sensor probe or an array of sensors arranged in a serpentine pattern across a duct to measure the average air temperature. Outdoor air temperature sensors should be shielded from the sun and located away from exhaust air vents or other objects which might affect the temperature reading.

The same precautions presented above also apply to humidity sensors. Because humidity sensors require more maintenance than most other types of sensors, it is desirable to locate them where they can be readily accessed.

All field wiring should be in accordance with the applicable local or Navy codes. It is recommended that the DDC unit, termination devices, and other components be housed in a suitably ventilated, lockable cabinet. Critical operating instructions should be posted on the inside of the cabinet door.

Commissioning

Commissioning is the process of putting a newly installed DDC system into proper working order. The commissioning process can be thought to consist of three parts: program verification, system tuning, and acceptance testing.

It is first necessary to determine if the control program is correct as written. Two types of programming errors are possible: errors in coding and errors in logic. Coding errors are errors in the way the control logic has been translated into computer language. Coding errors cause the program to work incorrectly, which is usually manifest by the control system doing something unexpected. Severe coding errors usually result in the program not working at all. Logic errors fall into two categories: those which are errors in the decision making process embodied in the existing coding, and those which are the result of omission of necessary logic. Checking a computer program for coding errors is usually a straightforward process, but detecting logic errors can be very difficult. Sometimes logic errors are found only after the DDC system has been in operation for a period of time and encounters conditions

not anticipated by the programmer. For this reason, it is recommended that the control program be kept as simple as possible. Problem diagnosis and correction is also facilitated if the computer program is written in modules, each of which has a specific purpose such as reading all the input data or controlling the chiller coil.

The control logic of a DDC system can be easily bench-tested in most units by varying the inputs and recording the outputs. For example, variable resistors, current sources, and switches can be used to simulate different input conditions. The sensor calibration curves are required to translate the input resistance (for example) into the simulated temperature, humidity, or pressure. The outputs from the DDC unit are then monitored to determine if the controller response is correct for the specific input conditions.

Tuning

Once the known problems (or bugs) in the control program have been corrected, the next step in system installation is to optimize the performance of the control system in relation to the specific HVAC system being controlled. This process is known as tuning and it basically involves determining the values for the proportional, integral gain, throttling range and other factors in the control algorithms such that smooth, stable system response will be achieved. System tuning is very important, for without correct tuning, a DDC system may perform no better than the poorest pneumatic control system. A method of tuning a simple (i.e., linear response) control loop is presented in Appendix B. Often, fine adjustments to the control system parameters are made after the system has been in use for a period of time and its performance using different values of control constants can be compared.

One area of current controls research is the development of an adaptive or self-tuning controller for HVAC systems. Because of the memory and computational capabilities of microcomputer-based control devices, it is theoretically possible to design a controller with sufficient artificial intelligence to be able to determine and set the values of control parameters which will produce optimum system performance. A well designed self-tuning controller could accommodate not only changes in load and setpoint, but also season changeover (heating to cooling, for example) and changes in equipment performance (e.g., coil fouling). A primary benefit would be the elimination of the need to hire the skilled personnel necessary to tune the controller for optimum performance. An excellent review of the status of adaptive controls research as applied to HVAC is presented in Reference 8. Reference 9 presents the results of an analytical and experimental study of adaptive control of an air handling unit.

The final task in the process of commissioning a DDC system is performing the acceptance test. The acceptance test is a planned test program to demonstrate that the DDC system will perform as specified. It is recommended that a test plan be developed that will lead the control program through all of the possible logic branches of the program. It is sometimes difficult to implement a full test program in the field environment in a brief period of time because of the lack of control the operator has over factors such as building load and outdoor air conditions. Usually a field acceptance test can be fully accomplished in a reasonable period of time only by substituting manually variable resistors for sensors and manually actuating switches as was described above in the discussion of bench testing.

Maintenance and Repair

Maintenance. A fundamental rule of any control system, DDC or otherwise, is that control effectiveness is limited by the performance of the equipment it is controlling. A DDC control system cannot make poorly designed or poorly maintained HVAC systems perform well. HVAC system problems, such as leaking pneumatic lines, dirty coils, and sticking valves, must be corrected before the DDC system is commissioned.

The routine maintenance required on a DDC control system is minimal. Routine calibration of the control system is not required. Also, because of the digital nature of the control system, it tends either to work or not to work. There is no degradation of performance over time as is commonly the case with analog control systems. Also, the self-diagnostic, data display, and alarm features of most DDC systems make trouble shooting of both control and HVAC system problems much easier.

Repair. The control system should be supported with an inventory of critical spare parts. A controls contractor can assist with generating a spare parts list. Usually the required spare parts inventory is very small. Key spares usually include controller circuit boards, sensors, and transmitters. System problems are usually corrected by replacement of the defective item. Repair of most components (circuit boards, sensors, etc.) requires skills and equipment which are generally not available to most Navy facilities managers.

Training

The maintenance people responsible for the DDC system will need a significant amount of training. Facilities managers should work with the control system vendor to develop a training program to educate maintenance personnel on the fundamentals of digital control, system operation, and trouble shooting. Refresher courses should also be scheduled on a regular basis. The importance of proper training of maintenance personnel and facilities managers cannot be overemphasized. Many aspects of DDC systems will be new to most personnel, so training must be designed to take some of the mystery out of "computer control," and emphasize how DDC can be more reliable and easier to maintain than conventional systems. Also, a review of the relevant HVAC system designs and operation and how a DDC system can be used in trouble shooting system problems is also a good training investment.

Many of the topics discussed in this section will be the subject of NAVFAC Guide Specifications to be published in the future.

V. SUMMARY

Direct digital control is finding increased application to heating, ventilation, and air conditioning systems for many reasons. A summary comparison of DDC and pneumatic control systems is presented in Table 3. Many different types of sensors can be used with a DDC controller. It is recommended that the extra investment be made in accurate, stable sensors as a DDC system cannot perform to full capability given poor input data.

Table 3. Summary Comparison of DDC and Conventional Control

Comparison Category	Conventional Pneumatic Controls	Direct Digital Control
Performance	<ul style="list-style-type: none"> • Proportional control only • Single loop controllers • Complex control is difficult or costly • Adequate control 	<ul style="list-style-type: none"> • Full PID control and more • Multi-loop controller • Easy to define complex sequences
Initial Cost	<ul style="list-style-type: none"> • Cost rises with number of control loops 	<ul style="list-style-type: none"> • Closer control • Once cost of DDC controller is absorbed, cost rises with number of sensors and actuators
Reliability	<ul style="list-style-type: none"> • Complex control is very expensive • Proven reliability over many years, however, control system must be well maintained and recalibrated regularly • Relies on air supply 	<ul style="list-style-type: none"> • Capable of most complex control • Proven reliability in process industry and many commercial HVAC applications
Maintainability	<ul style="list-style-type: none"> • Relatively easy to maintain • Require regular recalibration due to drift 	<ul style="list-style-type: none"> • Each DDC controller can stand alone • Automatic as-built • Built-in diagnostics • Fewer components • No drift • Service by board replacement
Flexibility	<ul style="list-style-type: none"> • Changes or additions require new or different controllers re-piping and often wiring, and then recalibration 	<ul style="list-style-type: none"> • Programmable controller • New control strategies defined at central • New control easily added
Ease of Use	<ul style="list-style-type: none"> • All operator interaction at local control panels • Can read temperatures and change set-point 	<ul style="list-style-type: none"> • Full English language reports • Color Graphic Displays • Automatic Records of all control strategies
Life Cycle Cost	<ul style="list-style-type: none"> • Requires regular recalibration • Modification and expansion require additional controllers 	<ul style="list-style-type: none"> • Easy to maintain • Easy to modify • Easy to expand

There are two basic methods of controlling proportional actuators: converting the digital value of the control signal produced by the DDC unit into an analog (i.e., continuous) voltage or air line pressure or using the digital signal directly to modulate an actuator. Both methods have proponents among manufacturers and control system designers. More experience with DDC is required before a preferred DDC-actuator interfacing method is identified. Thorough operator training prior to control system commissioning is required if the benefits of DDC are to be realized.

REFERENCES

1. "STORE CASE STUDY," by Mr. R. K. Rooney, ECC Controls Corp., Milwaukee, WI. A presentation to DIRECT DIGITAL CONTROL, a University of Wisconsin Engineering Extension Course, 12 May 1983.
2. "PERFORMANCE COMPARISONS," by Dr. D. C. Hittle, U.S. Army Construction Engineering Research Laboratory (CERL), Champaign, IL. A presentation to Direct Digital Control, a University of Wisconsin Engineering Extension Course, 11 May 1983.
3. "User's Guide to Sensors for Energy Monitoring and Control Systems," (draft) by G. A. Nowakowski, Naval Civil Engineering Laboratory, Port Hueneme, CA, Dec 1983.
4. Catalog, HY-CAL Engineering, Inc., Santa Fe Springs, CA, 1980.

5. "General Guidelines for the On-Site Calibration of Humidity and Moisture Control Systems in Buildings," by R. W. Hyland and C. W. Hurley, National Bureau of Standards (NBS) Science Series report 157, NBS, Washington, DC, Sep 1983.
6. "On-Site Calibration of Flow Metering Systems Installed in Buildings," by D. W. Baker and C. W. Hurley, NBS Science Series Report 159, NBS, Washington, DC, Jan 1984.
7. "Direct Digital Control of a Pneumatically Actuated Air-Handling Unit," by W. B. May, B. A. Bonesen, Ph.D., and C. W. Hurley. American Society of Heating, Refrigeration, and Air Conditioning Engineers (ASHRAE) paper TO-82-6, Aug 1982.
8. "Adaptive Control Strategies for Process Control: A Survey," by D. E. Seborg et al. A paper presented to American Institute of Chemical Engineers Annual Meeting, Washington, DC, Nov 1983.
9. "An Adaptive Controller for Heating and Cooling Systems: Modeling, Implementation, and Testing," by C. Park, NBS, and A. J. David, Bell Laboratories, Holmdel, NJ. American Society of Mechanical Engineers (ASME) paper 82-WA/DSC-22 or NBS report 82-2591, Oct 1982.
10. "Microprocessors in Instrumentation and Control," by R. J. Bibbero, John Wiley and Sons, New York, 1977.
11. "Optimum Settings for Automatic Controllers," by J. G. Ziegler and N. B. Nichols, ASME TRANSACTIONS, Nov 1942.
12. "Automatic Process Control," by D. P. Eckman, John Wiley and Sons, New York, 1958.

Appendix A

PROPORTIONAL-INTEGRAL-DERIVATIVE CONTROL

Let the desired value of the controlled variable be called the setpoint, V_{sp} . For example, it may be desired to control the temperature in a space to maintain a nominal value of 70°F. In this case, the setpoint equals 70. Let the actual measured value of the controlled variable be designated V_m , for measured variable. Any difference between V_{sp} and V_m is an error which the control system must try to eliminate. The output signal from a controller is dependent on the magnitude and algebraic sign of this error.

In a proportional controller, the output of the controller is simply a constant multiplied by the error. If

$$E = V_{sp} - V_m$$

then

$$G = K_p * E$$

where: G = controller output

K_p = proportional gain = a constant

In an integral controller, the output of the controller is a constant multiplied times the accumulated (or integral) error. Thus,

$$G = K_I * \int_{t_1}^{t_2} E dt$$

where: K_I = integral gain = a constant

dt = differential of time [time]

In a derivative controller, the output is a constant multiplied by the rate of change (or derivative) of the error signal.

$$G = K_D * dE/dt$$

where: K_D = derivative gain

dE/dt = rate of change of error

Usually, the integral and derivative gain factors are redefined in terms of the proportional gain:

$$K_I = K_p / T_I$$

where T_I = reset time [time]

and

$$K_D = K_p * T_D$$

where T_D = rate constant [time]

Thus, a PID controller has the form

$$G = K_p * E + K_I \int_{t_1}^{t_2} E * dt + K_D dE/dt$$

or

$$G = K_p * E + \frac{K_p}{T_I} \int_{t_1}^{t_2} E * dt + K_p * T_D * \frac{dE}{dt}$$

In the form of a finite difference equation,

$$G = K_p \left[E_N + \frac{T_s}{T_I} \sum_{i=1}^{i=N} E_i + \frac{T_D}{T_s} * (E_N - E_{N-1}) \right] \\ + \text{constant}$$

where: E_N = error signal at sample
n = setpoint - measured value
at time n

T_s = sample period [time]

T_I = reset time

T_D = rate constant

constant = mid-point position of
actuator = G_{mp}

A PID controller is presented in block diagram form in Figure A-1. A schematic of how the PID control method might be implemented is presented in Figure A-2.

The PID controller equations presented above are called the position forms or whole value forms of the control algorithm because they compute the absolute value of the position of the actuator continuously. Thus, in the event of a temporary loss of communication between the controller and the actuator, or loss of computing capability, the correct signal to restore the actuator to the proper position will be transmitted upon restoration of control.

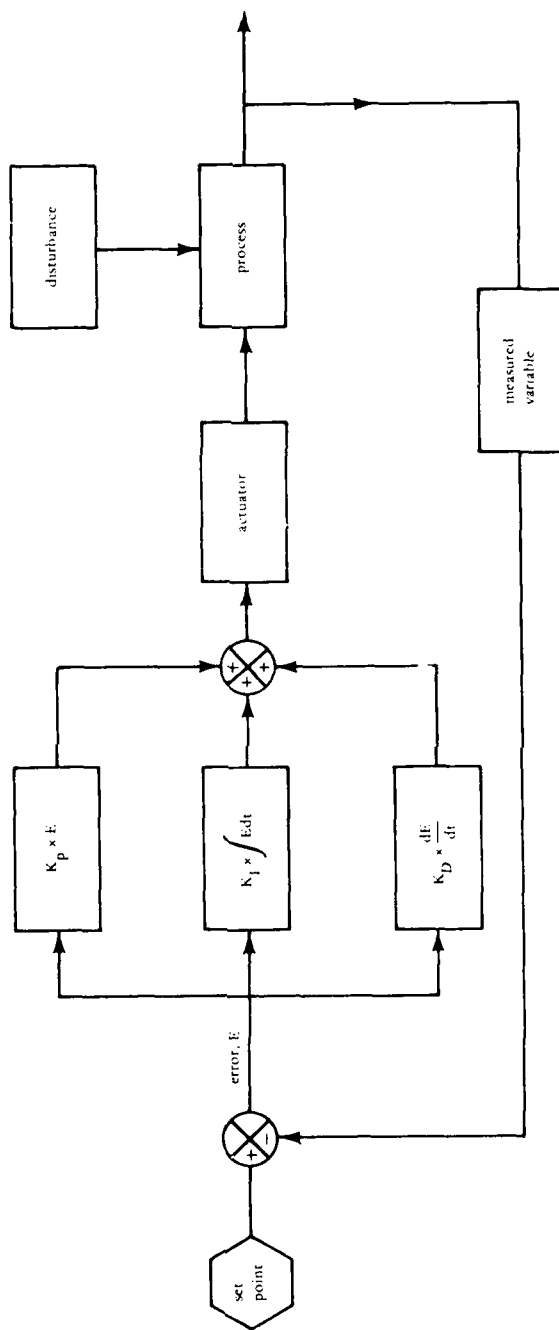

Figure A-1. Block diagram of PID Control Algorithm

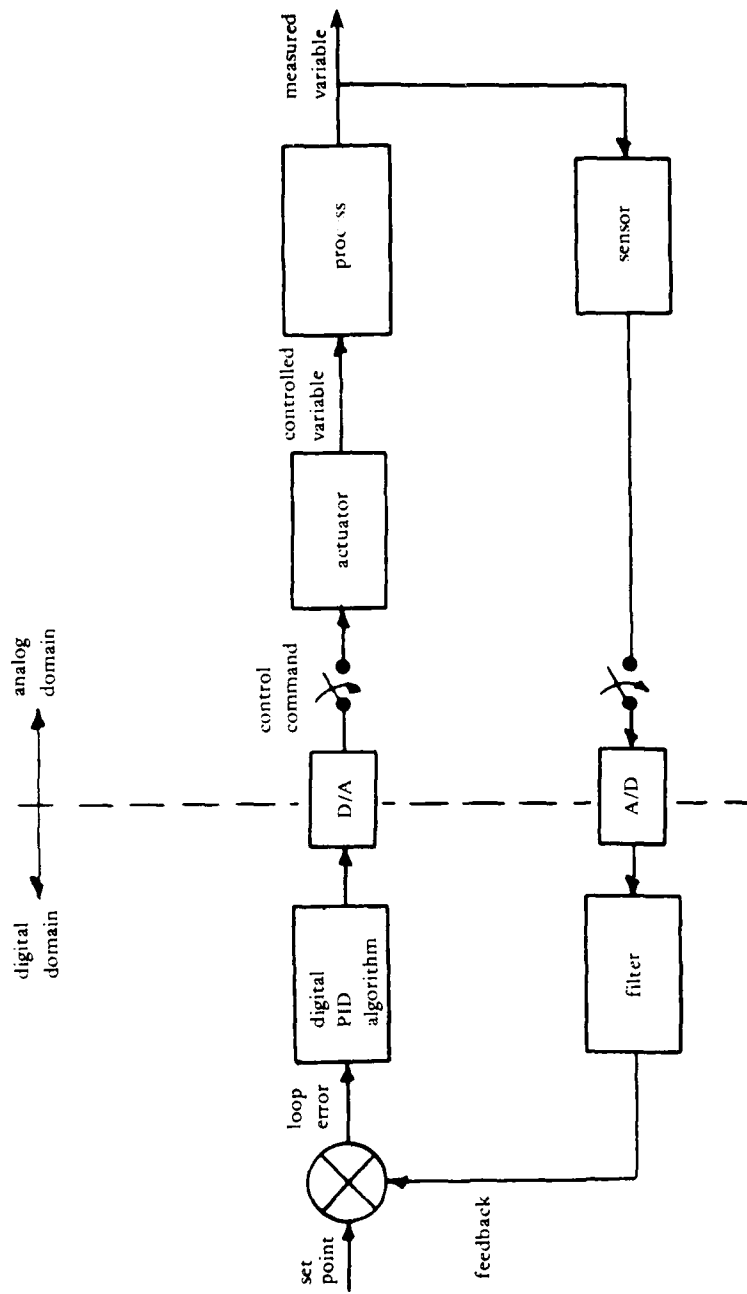

Figure A-2. Schematic of digital feedback control system.

Another form of the PID algorithm is the incremental value form or the velocity form. The incremental form of the PID algorithm is obtained by subtracting two successive values of position. Because only the difference between the currently computed whole value and the whole value from the previous calculation is transmitted to the actuator, only the change in position is transmitted to the actuator.

$$\begin{aligned}
 G_N - G_{N-1} &= \Delta G_N \\
 &= K_P * (E_N - E_{N-1}) + K_I * E_N * T_S \\
 &\quad + (K_D/T_S)(E_N - 2E_{N-1} + E_{N-2})
 \end{aligned}$$

The incremental form of the PID algorithm is better suited to many digital control systems where sampling is done at regular time intervals. An additional advantage is freedom from "windup," the condition in which the integral term of the controller reaches an upper limit value due to the persistence of an error signal.

If the positional form of the PID controller is used, the process will undergo a disturbance, or "bump," when control is switched between manual and automatic control unless the output of the controller is adjusted so as to coincide with the present position of the actuator. The incremental form of the algorithm however is "bumpless" because the average value setting, G , disappears when successive values of absolute position are subtracted.

If the final control element is a device which moves at a constant velocity, such as an electric motor which rotates at a constant speed, the distance the actuator moves will be directly proportional to the duration of the control signal applied to the actuator terminals. If the incremental form of the PID control algorithm is used

for control, then the change in actuator position is directly related to the duration and polarity of the output "pulse" from the controller. This method of control is widely used when gearmotors are employed as actuator drives. The method is called pulse-width-modulation or PWM control.

The equations presented above are for an ideal controller. In actual practice, the controller algorithm usually includes noise filters, error and limit detectors, and compensation for lead, lag and dead time. A good source of further information on control methods and digital control techniques is Reference 10.

Appendix B

CONTROL SYSTEM TUNING

The operator of a new DDC system is often faced with an immediate problem: for each local control loop the DDC system controls, at least one, and perhaps three or more numbers, must be entered into the controller as part of the instructions on how to operate. These three numbers are usually the proportional gain (K_P), the integral gain (K_I), and the derivative gain (K_D). The effects of these variables are illustrated in Figures B-1 through B-8.

Too large a value of K_P , however, results in unstable, or oscillatory, system behavior (Figures B-1 and B-2). A small value of K_P results in stable operation but a large residual, or offset, error (Figure B-3). An optimum value of K_P results in stable performance and an acceptable residual error (Figure B-4).

The residual error, however, can be eliminated by the addition of integral, or reset, control action. Integral control action is described by the factor K_I . The effect of integral action is illustrated in Figures B-5 through B-7. Too large a value for K_I results in an extended period of oscillation about the control point (Figure B-6). The effect of derivative control is to reduce peak excursions and dampen oscillations (Figure B-8).

B-1

PRECEDING PAGE BLANK-NOT FILMED

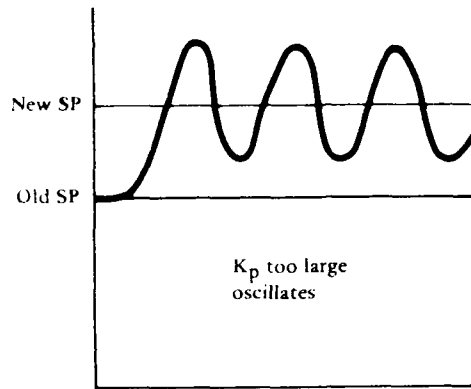

Figure B-1

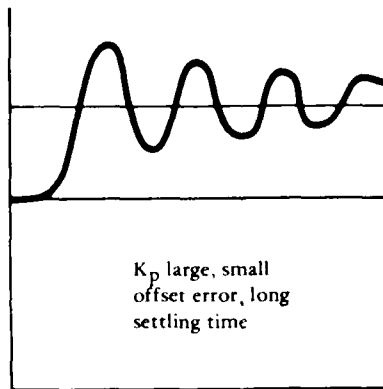

Figure B-2

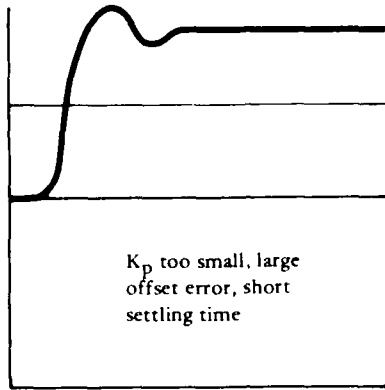

Figure B-3

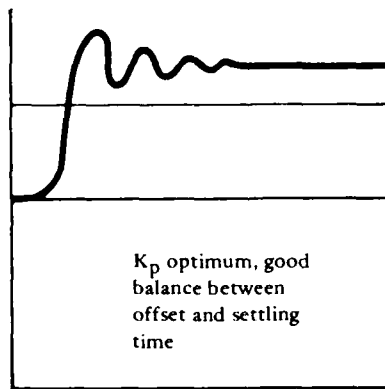

Figure B-4

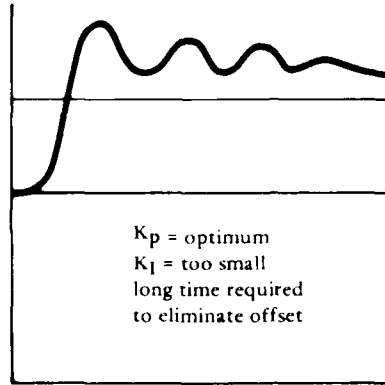

Figure B-5

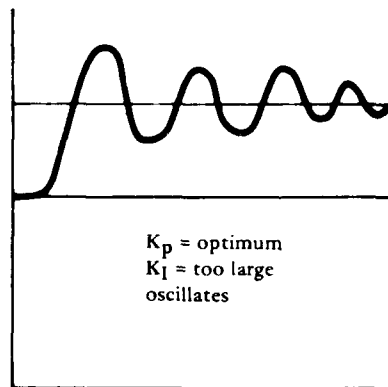

Figure B-6

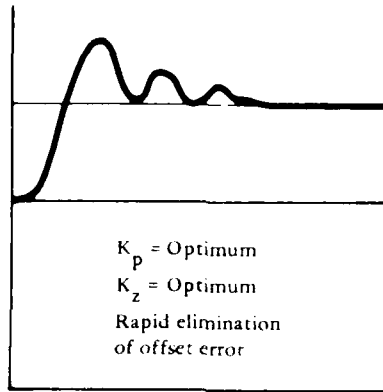

Figure B-7

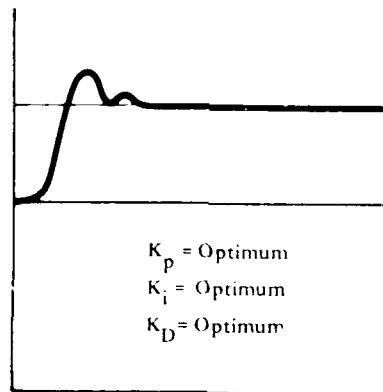

Figure B-8

How, then, does the operator determine what values of K_P , K_I , and K_D are correct for the control loops in the HVAC system?

One method of determining the response of an HVAC system to different control techniques is to develop a detailed mathematical model of the system and use any of several classical methods of analysis, such as Nyquist, root-locus, or Bode analysis to estimate system performance under various conditions. Unfortunately, developing a realistic mathematical model of even the simplest of HVAC control loops is usually a formidable task and performing the necessary analysis on the model requires specialized engineering training.

An experimental method, called the Ziegler-Nichols method after its developers (Reference 11), offers a systematic way of determining the controller settings for optimum performance of the controlled system and also provides a simple quantitative view of the behavior of the control system. The Ziegler-Nichols method is based on an approximation of a process composed of a single dead-time element and a single time constant element. The apparent dead time and the apparent time constant are used to estimate system performance. To a first approximation, the process simulates that of a linear valve-coil combination (time constant element) and a temperature sensor located downstream of the coil (dead-time element).

An open-loop transient test is used to determine the magnitudes of the dead time and time constant. Figure B-9 illustrates a general closed-loop control system. The system is made open loop by opening the connection between the controller and the actuator. A small step increase in controller output is then manually applied to the controlled device (Figure B-10).

The following precautions should be observed when conducting the open-loop transient response test:

(a) The input step change (M) should be as small in magnitude as possible that yields results that can be recorded and interpreted.

(b) If possible, the step change should be about the nominal setpoint, i.e., it should begin with the controlled variable just below the setpoint and end with the controlled variable just above the setpoint.

(c) No variable should be permitted to attain a maximum or minimum value, i.e., the test should be performed near the actuator mid-position.

(d) Actuators should be in good working condition so there is no significant hysteresis or dead zone in any element of the system.

After some dead time, the process will respond in a manner similar to that illustrated in Figure B-10. The process response is measured by the feedback loop sensor, for example, the temperature sensor used to control a coil. The system response should be measured and recorded. A strip chart recorder or similar device is very useful for recording system performance.

The open-loop response is approximated from the recorded response using the measured values illustrated in Figure B-11. The measured values are:

K = magnitude of the change in the controlled variable in units of the measured variable, e.g., °F

N = rate of change of controlled variable
in units of measured variable per
units of time, e.g., °F/min.

L = apparent dead time in units of time,
e.g., minutes

M = magnitude of step change in units of
controller output, e.g., volts or psi

As a check on applicability of the Zeigler-Nichols method, a horizontal line drawn at 63.2% of the total change, K, should give a value of time constant T which is approximately equal to the value of K/N. If the values of T and K/N are not within about 15 percent of each other, the system is appreciably nonlinear and the Zeigler-Nichols should be used only with caution. If it is suspected that the controlled system is nonlinear, the open-loop transient test should be performed in the other direction, i.e., a small step decrease in controller output is applied to the controlled device. If the measured values of T and L (taken in both directions) differ by more than 10 percent, the system is nonlinear.

The Cohen-Coon equations (Reference 12) are used to calculate the optimum controller variables

Proportional-Integral Control

$$K_p = \frac{M}{NL} \left(\frac{9}{10} + \frac{R}{12} \right), \frac{\text{units of M}}{\text{units of K}}$$

$$T_I = L \left(\frac{30 + 3R}{9 + 20R} \right), \text{ Time}$$

where

$$R = \frac{NL}{K} = \frac{L}{T}, \text{ dimensionless}$$

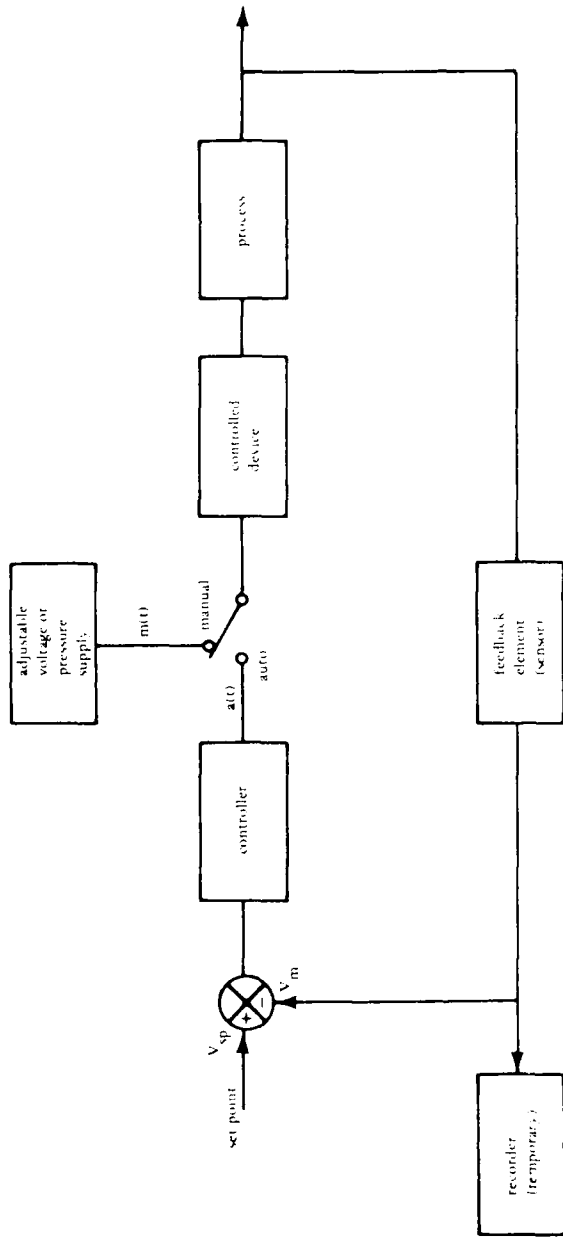

Figure B-9. General closed-loop control system equipped for open-loop test.

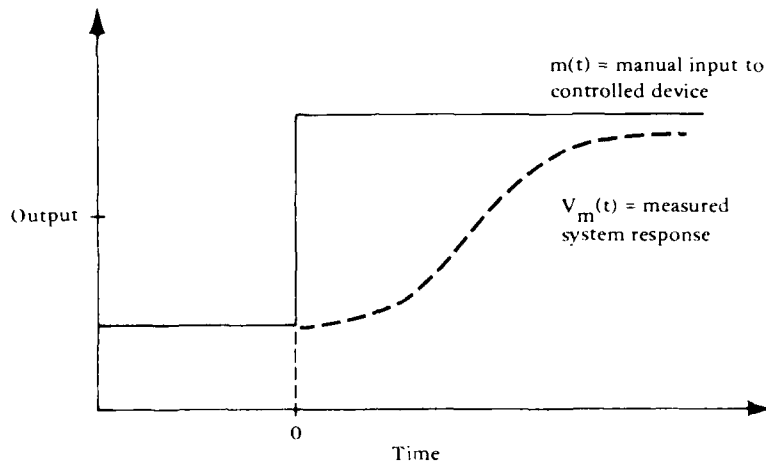

Figure B-10. Open-loop transient input and response.

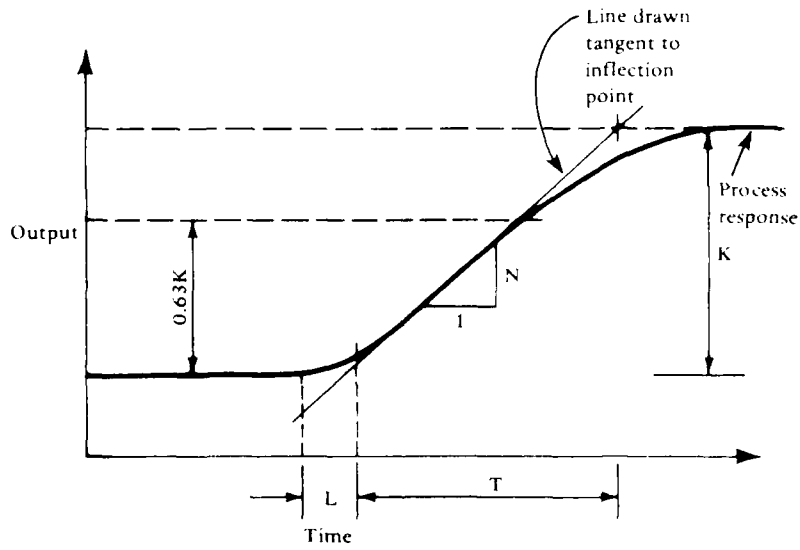

Figure B-11. Nomenclature for open-loop transient test calculations.

B-11

PRECEDING PAGE BLANK-NOT FILMED

If K_I is the controller adjustment rather than the reset rate, input

$$K_I = \frac{K_P}{T_I}$$

Proportional-Integral-Derivative Control

If the controller adjustments are expressed as K_p , T_I , and T_D , then

$$K_p = \frac{M}{NL} \left(\frac{4}{3} + \frac{R}{4} \right)$$

$$T_I = L \left(\frac{4}{11 + 2R} \right)$$

$$T_D = L \left(\frac{32 + 6R}{13 + 8R} \right)$$

R is defined above.

If the controller adjustments are input as K_p , K_I , and K_D , then

$$K_p = \frac{M}{NL} \left(\frac{4}{3} + \frac{R}{4} \right)$$

$$K_I = \left(\frac{3 + 2R}{6NL^2} \right)$$

$$K_D = \frac{M}{2N}$$

R is defined above.

After the optimum values for the controller gains have been calculated and input to the controller, a closed-loop transient response test can be performed by inputting a small change in

setpoint and measuring how the system responds. The equations presented above should result in a system response similar to that depicted in Figure B-8. The ratio of the amplitudes of successive oscillations should be about 4:1 and the area enclosed by the oscillations will be approximately a theoretical minimum. Settling time will also be minimized.

The Zeigler-Nichols tuning process can be automated with a microcomputer-based control system.

