

2

DOT/FAA/PM-86/28

Program Engineering  
and Maintenance Service  
Washington, D.C. 20591

# Investigation of Hazards of Helicopter Operations and Root Causes of Helicopter Accidents

AD-A171 994

Franklin R. Taylor  
Rich Adams

Systems Control Technology, Inc.  
2326 S. Congress Ave., Suite 2A  
West Palm Beach, Florida 33406

July 1986  
Final Report

DTIC  
SELECTED  
SEP 16 1986  
S D

This document is available to the public  
through the National Technical Information  
Service, Springfield, Virginia 22161

DTIC FILE COPY

**DISTRIBUTION STATEMENT A**  
Approved for public release  
Distribution Unlimited



U.S. Department of Transportation  
Federal Aviation Administration

80 9 16 048

A171 994

## Technical Report Documentation Page

1. Report No. DOT/FAA/PM-86/28	2. Government Accession No.	3. Recipient's Catalog No.	
4. Title and Subtitle INVESTIGATION OF HAZARDS OF HELICOPTER OPERATIONS AND ROOT CAUSES OF HELICOPTER ACCIDENTS		5. Report Date July 1986	
		6. Performing Organization Code	
7. Author(s) Franklin R. Taylor and Richard J. Adams		8. Performing Organization Report No.	
9. Performing Organization Name and Address Systems Control Technology, Inc. 1611 N. Kent Street Suite 905 Arlington, VA 22209		10. Work Unit No. (TRAIS)	
		11. Contract or Grant No. DTFA01-80-C-10080/Mod. 0034	
12. Sponsoring Agency Name and Address Federal Aviation Administration Navigation and Landing Division Helicopter Program Branch, APM-450 800 Independence Ave., Washington, D.C. 20591		13. Type of Report and Period Covered FINAL REPORT October 83 - September 85	
		14. Sponsoring Agency Code APM-450	
15. Supplementary Notes			
16. Abstract During 1983 and 1984, Systems Control Technology, Inc. conducted a survey of civil helicopter pilot organizations from throughout the United States who were involved in a wide range of helicopter operations for the purpose of determining the hazards of helicopter operations and the root causes of the high rate of helicopter accidents. The survey was administered through personal interviews, meetings, and questionnaires. The derived questionnaire data included census data, profiles of the pilots work environment and procedures and their own perspectives on the hazards of helicopter operations and root causes of helicopter accidents. These data were compared with historical National Transportation Safety Board accident reports and accident briefs to determine more specifically the root causes of helicopter accidents. The results of the analysis include a list of hazards and probable root causes of accidents, as well as technological, training and standardization remedies to the causes.			
17. Key Words Helicopter, accidents, autorotation, hazards, pilot error		18. Distribution Statement Document is available to the U.S. public through the National Technical Information Service, Springfield, Virginia 22161.	
19. Security Classif. (of this report) Unclassified	20. Security Classif. (of this page) Unclassified	21. No. of Pages 170	22. Price

## TABLE OF CONTENTS

Table of Contents	i
Figures	iii
Tables	iv

<u>SECTION</u>	<u>PAGE</u>
1.0 EXECUTIVE SUMMARY	1
1.1 OVERVIEW OF THE KEY ISSUES	1
1.2 INTRODUCTION	2
1.2.1 Scope	2
1.2.2 Program Objectives	3
1.2.3 Method of Approach	4
1.3 SUMMARY OF RESULTS AND CONCLUSIONS	5
1.3.1 Significant Survey Findings	5
1.3.2 Summary of Root and Contributing Causes	6
1.3.3 Other Significant Findings	6
1.3.4 Summary of Pilot Perspectives of Root Causes of Helicopter Accidents	7
2.0 METHOD OF APPROACH	8
2.1 TASK E-4(a) -- HELICOPTER HAZARDS DEFINITION	9
2.2 TASK E-4(b) -- OPERATIONAL DATA COLLECTION	9
3.0 ROTORCRAFT HAZARDS ANALYSIS - GENERAL	11
3.1 PILOT SURVEY	15
3.1.1 Surveyed Pilot Census	16
3.1.2 Types of Helicopters Operated by Surveyed Pilots	21
3.1.3 Survey Pilots' Operating Environment	24
3.2 ANALYSIS OF HAZARDS OF HELICOPTER OPERATIONS AND ACCIDENT CAUSES	30
3.2.1 Pilot-Inadequate Preflight Preparation and/or Planning	35
3.2.2 Powerplant-Misc-Failure for Undetermined Reasons	48
3.2.3 Pilot-Failed to Maintain Adequate Rotor RPM	73
3.2.4 Pilot-Failed to See and Avoid Objects or Obstructions	79
3.2.5 Other Accident Causes	84
3.3 PILOT PERCEPTIONS OF ROOT CAUSES OF HELICOPTER ACCIDENTS	89
3.3.1 Comparison of Pilot Perspectives to NTSB Data	90
3.3.2 Fatigue	92
3.3.3 Safety R&D Requirements	94
3.3.4 Anecdotal Operator Comments	102
4.0 CONCLUSIONS AND RECOMMENDATIONS	106
4.1 SIGNIFICANT SURVEY FINDINGS	106
4.2 SUMMARY OF ROOT CAUSES OF HELICOPTER ACCIDENTS	109

TABLE OF CONTENTS

(Continued)

<u>SECTION</u>	<u>PAGE</u>
4.3 OTHER SIGNIFICANT FINDINGS	113
4.4 SUMMARY OF PILOT PERSPECTIVES OF ROOT CAUSES OF HELICOPTER ACCIDENTS	115
4.5 SUMMARY OF RESEARCH RECOMMENDATIONS	116
REFERENCES	118
Appendix A - Detailed Methodology for Both Phase One and Phase Two of the Operator's Survey	A-1
Appendix B - Interview Information Package	B-1
Appendix C - Sample Surveys	C-1
Safety R&D Survey	C-1
Phase One Helicopter Operations Survey	C-5
Phase Two Hazards Survey Questionnaire	C-13



List of Figures

<u>Figure</u>	<u>Page</u>
3.1 Comparison of Sample Population to Distribution of U.S. Civil Helicopter Operators	15
3.2 Pilot Ranking of Restrictions to Approach Directions (Assuming Favorable Wind Direction)	28
3.3 Autorotative Glide Distances, Bell 205	58
3.4 Height Velocity/Diagram - Typical Turbine Helicopter	63



Accession For	
NTIS CRA&I	<input checked="" type="checkbox"/>
DTIC TAB	<input type="checkbox"/>
Unannounced	<input type="checkbox"/>
Justification	
By	
Distribution/	
Availability Codes	
Dist	Avail and/or Special
A-1	

List of Tables

<u>Table</u>	<u>Page</u>
1.1 Program Scope - Phases One and Two	3
2.1 Sources of Phase Two Survey Data	8
2.2 Initial Phase Two Operational Interview Participants	10
2.3 Additional Phase Two Operational Interview Participants (Group Meetings)	11
3.1 Surveyed Pilot Qualification Summary	17
3.2 Percent of Civil Helicopter Pilot Certificates Awarded to Military Pilots	17
3.3 Pilot Experience Summary (Surveyed Pilots)	20
3.4 Summary of Helicopters Flown by the Survey Group	23
3.5 IFR Equipage of the Survey Sample by Operator Group	24
3.6 Typical Avionics Expenditures Per Aircraft By Operator Group	24
3.7 Survey Sample Flight Mission Duration and Landing Frequency	25
3.8 Survey Sample Helicopter Operating Altitudes	29
3.9 Mean Operating Altitudes by Operator Group	29
3.10 Helicopter Accident Rates, 1975-1980	30
3.11 Most Prevalent Detailed Accident Causes - 1980	31
3.12 Comparison of Detailed Causes, FW-RW	33
3.13 Pilot Qualification Summary - 1980 "Pilot-Inadequate Preflight Accidents	36
3.14 Survey Results: Available Flight Preparation Time (by Operator Group)	37
3.15 Survey Results: Time Allocation During Performance of Preflight Tasks (by Operator Group)	38
3.16 Detailed Cause - Pilot-Inadequate Preflight Accidents, 1980	41
3.17 Summary of Root Causes "Pilot Inadequate Preflight Preparation and/or Planning" Accidents	46
3.18 Comparison of Powerplant Failure-Undetermined Cause Accidents Rates - FW/RW (1980)	48
3.19 Comparison of Degree of Injury of Engine Failure Accidents - FW/RW (1980)	49
3.20 Survey Results: Perception of Relative Risk of Engine Failure (by Phase of Flight)	51
3.21 Summary of Causes - Powerplant Fuel Starvation (NTSB - 1980)	53
3.22 Sources of Engine Failures Resulting in an Accident (1980)	55
3.23 Relative Risk of Unsuccessful Autorotation by Phase of Flight	63
3.24 Most Frequently Flown Descent Angles and Approach Airspeeds	64
3.25 Pilot Approach Profiles	64
3.26 Accident and Incident Autorotation Ratio by Helicopter Type	66
3.27 Ratings Held by Pilots in 1980 Autorotation Accidents/Incident	68
3.28 Comparison of Civil & Military Pilot Autorotation Experience, 1980	69

List of Tables  
(Continued)

<u>Table</u>	<u>Page</u>
3.29 Survey Results: Annual Number of Practice Emergency Procedures (by Operator Group)	71
3.30 Summary of Root Causes of Powerplant Failure Accidents (2 pages)	74
3.31 Type of Flying for "Pilot-Failed to Maintain Rotor RPM" Accidents, 1980	76
3.32 Summary of Root Causes of "Pilot-Failed to Maintain Rotor RPM" Accidents (2 pages)	80
3.33 Types Helicopters Involved in Wire Strike (Sole Cause) Accidents (1980)	82
3.34 Root Cause of Pilot-Failed to See and Avoid Objects or Obstructions Accidents	85
3.35 Main Rotor System Failure Modes, 1980	86
3.36 Tail Rotor Failure Modes/Causes, 1980	88
3.37 Pilot Ranked Accident Categories	91
3.38 Summary Operator Defined Research Requirements for Current Aircraft	96
3.39 Summary of Operator Defined Research Requirements for Future Aircraft (2 pages)	97
3.40 Operator Opinions (2 pages)	104
4.1 Summary of Hazards of Helicopter Operations and Root Causes of Helicopter Accidents (2 pages)	111

In 1980, the most recent year for which detailed National Transportation Safety Board (NTSB) rotorcraft accident statistics are available, helicopter pilots compiled an accident rate of 13.91 accidents per 100,000 aircraft hours flown. During that same period, general aviation fixed-wing accidents occurred at a rate of 9.47 accidents per 100,000 aircraft hours flown. The disparity between the accident rates for the two types of aircraft is even more revealing when one considers that almost 30 percent of all fixed-wing aircraft hours flown are accumulated by private pilots with considerably less flight experience than rotary wing pilots. By comparison, less than five percent of all rotorcraft hours flown are by private rotorcraft pilots. The rotorcraft accident rate exceeds the general aviation fixed-wing rate by more than 46 percent. However, a recent study of flight estimates for rotorcraft indicate that this difference is inflated. (Reference, "Rotorbreeze," published by Bell Helicopter Textron, April, May 1985, Vol 34, No 3)

In order to understand this disparity, it is necessary as a first step to understand the nature of helicopter operations and the environment in which they operate. This study of the hazards of helicopter operations was designed to collect data from helicopter pilots to provide insight regarding hazards, to identify root causes of helicopter accidents and, where possible, to suggest corrective measures or necessary fixes to alleviate the hazard problem.

#### 1.1 OVERVIEW OF THE KEY ISSUES

In order to determine the hazards of helicopter operations and to calibrate the pilot survey results, an examination of the "most prevalent" detailed accident causes for rotary wing (RW) and fixed-wing (FW) aircraft was performed. These NTSB defined causes were compared to pilot perspectives and quantitative data obtained from a hazard survey questionnaire. A comparison was made of the contribution of each of the causes (in which appropriate FW-RW comparison can be made) to their corresponding accident rates. Correlation coefficients were computed for combined pilot and material caused accidents, and for pilot error only accidents. For the combined statistics, no correlation was found. However, when accidents already attributable to material failure were removed, a high degree of correlation existed between FW and RW pilot error accidents. In addition, the FW and RW pilot error accident rates were identical at 8.6/100,000 hours. Several hypotheses are explored to explain this correlation in the analysis section. However, the discovery of this rather unexpected correlation resulted in the formulation of several key questions and issues that comprise the major portion of the analysis of both questionnaire responses and accident statistics. These key issues are:

- o The pilot error accident rate for helicopter and general aviation are identical, although 75 percent of the helicopter pilots are FAA commercially rated.
- o Accident investigation training should be expanded to include the helicopter environment.
- o Engine reliability in the helicopter environment should be improved.
- o The rate of unsuccessful autorotations for low inertia rotors is 2.5 to 3.0 times greater than high inertia systems.
- o Establishment of details delineating (root) causes of pilot error helicopter accidents.
- o Alleviation or elimination of recurring or most prevalent detailed causes of helicopter accidents/incidents through prudent application on modern technology, delineating corrective measures and/or suggestions.
- o Delineating the difference in single engine versus multiengine helicopter accident rates.

## 1.2 INTRODUCTION

This analytical effort is aimed at defining the helicopter pilot's exposure to various hazards during execution of normal operations. In order to accomplish this goal, a helicopter hazard survey was used to poll the sample pilots concerning environmental and operational factors which could influence their operations. Areas of particular interest regarding the respondent's operations were:

- 1) Length of mission
- 2) Number of takeoffs/landings per mission
- 3) Percent of flight time per phase of flight
- 4) Percent of flight time at various airspeeds
- 5) Operating altitudes
- 6) Types of landing areas
- 7) Percent VFR versus percent IFR flight time
- 8) Percent day versus percent night flight time

### 1.2.1 Scope

This study examined and analyzed the hazards of helicopter operations for various mission types. Table 1.1 presents a summary of the tasks and period of performance of this effort.

### 1.2.2 Program Objectives

During Phase One of this study (1980-82), it was concluded that a major discrepancy existed between the pilot's perception of the underlying causes of accidents and the data gathered and analyzed by the National Transportation Safety Board. Basically pilots at that time felt that equipment failures were the major causes while NTSB data pointed the finger at the pilot. This is not surprising, since pilot training stresses a considerable amount of learning about the intricacies and failure modes of the machine, the vagaries of meteorology, emergency procedures, etc. Little time is devoted to studying the human element the pilot which is probably the most vulnerable part of the total system, composed of man, machine, and the environment. Conversely, the NTSB in finding of the "cause" of an accident to be "pilot error" does not arrive at the true root cause.

Table 1.1 Program Scope - Phases One and Two

<u>PHASE</u>		<u>TASKS</u>	<u>PERIOD OF PERFORMANCE</u>
ONE	PART 1	o STUDY PLAN	20 NOV. 1980
		o DATA ACQUISITION PLAN	TO
		o QUESTIONNAIRE FORMAT	20 SEPT. 1981
-----			
ONE	PART 2	o PRELIMINARY INTERVIEWS	20 SEPT. 1980
		o PRELIMINARY RESULTS & ANALYSIS	TO 20 JUNE 1982
-----			
TWO		o DATA COLLECTION AND HAZARD DEFINITION	12 SEPT. 1983 to 24 MAY 1984
		o DRAFT REPORT	12 SEPT. 1984
		o SAFETY WORKSHOP	19 SEPT. 1984
		o ADDITION DATA ANALYSIS AND REPORT PREPARATION	15 JAN. 1985 to 9 SEPT. 1985

As a result, Phase Two of this study was initiated (1983-84) with three primary objectives:

- o Determination of the pilot perception of the operational hazards and underlying causes involved in various helicopter missions through a survey of helicopter operator/pilot groups.

- o Correlation of the hazards of helicopter operations through an analysis of historical accident reports and statistics in conjunction with survey results and a literature search.
- o Definition of the underlying or root causes of those helicopter accidents/incidents attributable to pilot error.

### 1.2.3 Method of Approach

The basic method of approach used to evaluate the hazards of helicopter flight and determine the possible root causes of pilot error accidents included:

- o A historical literature survey.
- o Field interviews of a sample of helicopter operators.
- o Detailed analysis of accident/incident statistics.
- o An assessment of most prevalent detailed accident causes for comparison with field interviews and evaluation of potential solutions.

The significance of this analysis lies in the fact that pilot error or human factor accidents are a major problem in national and international civil and military helicopter operations. The majority of these accidents are related to errors in operational technique, judgement (or decisionmaking) and errors in perception. However, underlying and contributing to these errors are fatigue, excessive pilot workload, stress, nutrition, discomfort, misinformation and other factors. Most of the accidents involve wire-strikes, rotor strikes, snagged skids, overloading, fuel starvation, problems caused by wind gusts and landing on uneven or soft terrain or obstacles. It is commonly accepted that despite all reasonable efforts, accidents will occur. However, the frequency of occurrence of pilot error accidents is excessive. Therefore, by investigating the relationship between the accident (i.e., rotor strikes), the contributing factors (fatigue, workload, etc.) and the broad accident category (i.e., operational technique) it is hoped that sufficient understanding of the root causes will be gained to determine corrective measures and technological fixes. To accomplish this decomposition of pilot error into root causes the statistical accident data from various sources were examined and related to quantitative and qualitative data from a pilot survey. The survey was designed to poll nine official respondents through a series of telephone interviews, meeting and distribution of the Hazard Survey Questionnaire (Appendix B). Using procedures developed during Phase One (Appendix A) data were obtained on the subjects perspective on rotorcraft hazards and the pilot

workloads associated with various mission types both IFR and VFR. These data were used to determine the perception of root-causes which are often masked and not obvious during post-accident/incident investigations and statistical analyses. The nine official respondents provided an unexpected additional source of data. Upon participating in this task, they frequently requested additional questionnaires to be distributed to their peers. In this manner, although the distribution was somewhat uncontrolled, a total of 108 questionnaires were received. Since these were all voluntary respondents, not all questions were responded to by all participants and not all respondents answered to the same depth. However, interesting and pertinent data was obtained on many of the most prevalent accident types. Detailed analysis of these data were performed in Section 3.0. The following discussion presents the highlights of the primary results.

### 1.3 SUMMARY OF RESULTS AND CONCLUSIONS

The primary findings of this study are presented in detail in Section 4.0. They will be briefly summarized in this section and categorized into the same four groups discussed in Section 4.0. The categories include:

- o Significant Survey Findings
- o Summary of Root Causes of Helicopter Accidents
- o Other Significant Findings
- o Summary of Pilot Perspectives of Root Causes of Helicopter Accidents

#### 1.3.1 Significant Survey Findings

The results of the survey were used to provide answers to several pertinent questions regarding the hazards of helicopter operations. These answers are summarized in the following text as conclusions. The data and rationale for those conclusions are presented in detail in Sections 3.0 and 4.0, respectively.

- o The single factor which has the highest impact on the high helicopter accident rate is pilot training. For example, accidents which result from failed autorotations following engine failure are largely due to inadequate pilot training and proficiency.
- o Instructional flying demonstrates a high rate of helicopter accidents due to the prevalence of piston powered helicopters in flight training, the control sensitivity, workload and reliability associated with those models.



- o Aerial applications (agricultural) accident rates for piston helicopters are slightly less than fixed-wing rates and less than the overall piston helicopter rate.
- o The high piston accident rate is a function of powerplant reliability, aircraft controllability and rotor system design.
- o Two aspects of the helicopter's mission profile seem to affect the accident rate. The first element is the length of the average mission; the second element is the amount of time spent in takeoff/landing and hovering phases of flight.

### 1.3.2 Summary of Root and Contributing Causes

Section 4.2 presents a detailed table of the causes of helicopter accidents. This table lists the system failure, how it failed (contributing cause), why it failed (root cause) and corrective measures or remedies. In total, 22 failure types are presented and 42 root causes identified. Many of these root causes occur repeatedly for similar failures. Also, many of the failures have multiple root causes. Table 4.1 should be referred to for the specific correlation of all failures, root causes and proposed remedies. Highlights of the data from Table 4.1 are as follows:

- o Pilot Caused Accidents -- Root causes consisted of fatigue, impaired judgement, overconfidence, complacency, operating with inadequate weather information, and inadequate training.
- o Control System Accidents -- Root causes consisted of nonstandard throttle configuration between aircraft, uncoordinated throttle, collective and pedal control operation.
- o Powerplant Failures -- Root causes included inappropriate design for mission and accelerated wear due to mission requirements.
- o Environment Caused Accidents -- Root causes included terrain, meteorological restrictions and obstacles.

### 1.3.3 Other Significant Findings

These findings relate to insufficiencies or deficiencies in the data needed to accurately determine and correlate root causes for each type of accident. They include:

- o An unquantifiable bias exists in the FAA Airmen Certification Registry due to the significant number of active and inactive military pilots included in the commercial/instrument category who do not engage in civil helicopter flights. (See Section 3.1.1.)
- o NTSB characterization and categorization of helicopter accidents is insufficient for the purpose of establishing root causes of helicopter accidents, and for developing corrective actions to preclude further accidents.
- o Historically accident investigation training has been directed towards fixed-wing operations. This training has proven satisfactorily for fixed-wing general aviation accident investigation; however, the complexity of the helicopter environment, operations and flight capability, has dictated that the training be revisited. This lack of specialized training could be a contributing factor in unexplained accidents being attributed to pilot error.

#### 1.3.4 Summary of Pilot Perspectives of Root Causes of Helicopter Accidents

This section summarizes the conclusions and recommendations presented in Section 4.4. Basically two types of pilot perspectives were derived from the survey. These were the pilot's perspective of accident causes and the pilot's recommended future action (Section 4.4). In summary,

- o Pilots are largely aware of their contribution to the high helicopter accident rate. They rated pilot error as a cause in 38 percent of the accidents. This compares to the official NTSB figure of 60 percent where the pilot was either the cause of, or contributed to, the accident (See Section 3.3.1).
- o Pilots believe equipment failures account for a relatively small (22 percent) portion of the accidents.
- o Pilots tend to over estimate the importance of instrument meteorological conditions (31 percent) as a factor in aircraft accidents. NTSB data showed only 12.5 percent of all accidents were either caused by, or contributed to by, weather (See Section 3.3.1).
- o Pilots recommend future R&D be focused on safety (automated systems, standardized controls and switches, etc.), human factors (cockpit comfort, safety awareness, training, proficiency, etc.) and vehicle design (icing certification,

crashworthiness, handling qualities) as the three most important areas for both current and future rotorcraft.

2.0

METHOD OF APPROACH

The material presented in this section provides a general understanding of the methodology used in Phase One and Phase Two of this study of civil helicopter operations. The detailed overall methodology for both Phase One and Phase Two is presented in Appendix A. The following discussion provides the highlights, of the issues involved, the inputs required and the outputs expected.

The primary elements of Phase Two were the identification of hazards of helicopter operations, the operational data collection, data analysis and preparation of the final report. A preliminary analysis of helicopter hazards had been performed in Phase One, and very little data were collected from the operator groups in Phase One, therefore, the early emphasis in Phase Two was focused on operational data collection. Table 2.1 lists the sources of survey data. Eight of the fourteen groups were interviewed during the first six months of the period of performance. This early emphasis on operator/pilot perspectives accomplished two objectives. First, it facilitated and expedited the development of a data base from notes taken during the interviews, questionnaire data collected, and perspectives gained during the discussions. Second, it provided a complementary operator/pilot data base to be used as a sounding board in discussions with manufacturers, analysis of NTSB statistics, etc.

Table 2.1 Sources of Phase Two Survey Data

---

1) *	Professional Helicopter Pilots Association of California	-	PHPA
2) *	Helicopter Safety Advisory Conference	-	HSAC
3) *	Appalachian Helicopter Pilots Association	-	AHPA
4) *	Helicopter Association International	-	HAI
5) *	American Helicopter Society	-	AHS
6) *	Commercial Helicopter Operators Council	-	CHOC
7) *	Northwest Helicopter Association	-	NHA
8) *	Bell Helicopter Textron	-	BHT
9) *	Sikorsky Aircraft	-	S IK
10) **	Helicopter Association of Florida	-	HAF
11) **	Airborne Law Enforcement Association	-	ALEA
12) **	Helicopter Operators of Texas	-	HOT
13) **	Eastern Region Helicopter Council	-	ERHC
14) **	Michigan Helicopter Association	-	MHA

---

NOTE: \* Initial operator survey subject groups  
\*\* Additional volunteer responses

The second task involved reexamination of NTSB historical accident data for the years 1977-1980 (References 1 and 2). Special attention was paid to accident data for the year 1980, since for that year, accident briefs for the 263 helicopter accidents reported and categorized in the "Annual Review of Accident Data, 1980" were available. These data were supplemented by the survey data acquired through onsite interviews and hazard survey questionnaires in order to postulate the helicopter operational hazards and root causes of helicopter accidents. These hazards are thoroughly discussed in Section 3.2. The following discussion provides more detail on the form and substance of the data collection/data analysis performed during Phase Two on a task by task basis.

#### 2.1 TASK E-4(a) -- HELICOPTER HAZARDS DEFINITION

This task developed and finalized the definition of the hazards of helicopter operations through the analysis of historical rotorcraft accident/incident reports and statistics. In addition to the four primary data sources previously discussed, References 3, 4, 5, 6, 7, and 8 were extremely helpful in understanding the statistics and substantiating conclusions based on survey data.

These reports provided depth and guidance in performing the historical accident data analysis. Data from them were used to cross reference survey results throughout the analysis. Specifically, the knowledge and experience available from these references was used to identify and substantiate the recognized safety hazards and to determine the primary environment, human factor or aircraft design solutions.

#### 2.2 TASK E-4(b) -- OPERATIONAL DATA COLLECTION

Using the data and information from Phase One, Tasks E-1(a), (b), (c) and (d), (See Appendix A) operator interview/meetings were conducted as a primary data source for this task. The purpose of these interviews/meetings was to determine the current operational safety environment. The primary subjects for these interviews and their affiliation are listed in Table 2.2.

The initial contacts and the interviews were conducted in the identical manner previously used in Phase One (see Tasks E-1(b) and E-1(c) Appendix A). Telephone contacts, follow-up mailings, personal interviews and data collection were successfully accomplished with all nine subjects. However, the consistency and quantity of data gathered did vary in the following manner:

1. Subjects 3, 4, 7 (HSAC, PHPA and AHPA) in Table 2.2 were successfully run through the entire set of planned interview, data collection follow-up, revised data process including participation of other group members.

2. Subjects 1, 2, 8, 9 were interviewed by telephone and met with personally in a one-on-one situation.
3. Subjects 5 and 6 were unavailable for personal interviews or meetings and therefore were only interviewed by telephone.

Table 2.2 Initial Phase Two Operational Interview Participants

NAME and TITLE	AFFILIATION
1. William D.C. Jones Director of Safety	Helicopter Association International
2. John F. Zugschwert Executive Director	American Helicopter Society
3. Lynn Clough Chairman	Helicopter Safety Advisory Council
4. Robert McDaniels President	Professional Helicopter Pilots Assoc.
5. Wanda Rogers President	Commercial Helicopter Operators Council
6. Al Scott President	Northwest Helicopter Association
7. Dee Young President	Appalachian Helicopter Pilots Assoc.
8. Roy Fox, Chief, Safety Engineer	Bell Helicopter Textron
9. Chris Fuller Chief of Systems Safety	Sikorsky Aircraft

Since the operational perspective was such a critical element of this effort, it was formatted to encourage additional volunteer data and thereby enhance both the quality and quantity of the interview data. Table 2.3 lists the additional operator groups participating in the entire interview process described in Task E-1(c). Substantive data were obtained from each of these groups. The procedures used to collect data are described in Appendix A. These procedures allowed the determination of the operators'/pilots' perspective on helicopter safety hazards, for VFR, SVFR and IFR operations and for various levels of pilot workload associated with flying different helicopter types. The net result of this interview process was a delineation and definition of the operators/pilots perception of the root-causes of helicopter pilot error accidents. These causes are often masked and not obvious during post accident/incident investigations and frequently not sufficiently explained in statistical accident analyses. The root causes are presented and thoroughly analyzed in Section 3.3. A safety R&D workshop was held to document these results and present them with the results of the literature review from Phase One.

Table 2.3 Additional Phase Two Operational Interview Participants  
(Group Meetings)

---

1. Helicopter Association of Florida	- HAF
2. Airborne Law Enforcement Association	- ALEA
3. Helicopter Operators of Texas	- HOT
4. Eastern Region Helicopter Council	- ERHC
5. Michigan Helicopter Association	- MHA

---

### 3.0

#### ROTORCRAFT HAZARDS ANALYSIS - GENERAL

In the following section the results of the hazards survey analysis are presented. The analysis begins with a presentation of the census of survey respondents, in which the age, flight experience, qualifications, type aircraft, and mission profiles of the sample will be compared with the civil helicopter pilot population as a whole. Section 3.1 will also provide a discussion of the questionnaire data relating to the pilot perceptions of root causes of helicopter accidents. Section 3.2 provides a detailed analysis of 1980 NTSB accident data, and compares that data to selected pertinent information provided by pilots through the survey.

From this analysis, a list of root causes is presented, as well as recommendations to minimize their effects. Section 3.3 compares surveyed pilot perceptions of the causes of helicopter accidents with accepted NTSB cause assignments, as derived from questionnaire data and onsite interviews.

#### SURVEY LIMITATIONS

The survey sample, upon whose responses many of the conclusions presented in later sections of this document rely, was not intended to be, nor is it presented to be, a statistically valid slice of the civil helicopter population. Several factors force this situation.

The primary factor affecting the statistical significance of the sample was that rather than being a purely random sampling of the population, as may have been possible through the random selection of pilots from a master list or registry, the survey was directed to a preselected list of pilots, manufacturers, and other persons interested in the promotion of helicopter operations. Moreover, the sample was limited contractually to only nine representative operator groups in order to avoid burdening helicopter pilots with what may have been perceived to have been an unwarranted FAA intrusion into their operations. Despite the limitation of only nine preselected target groups, it was possible to obtain questionnaire data from 108 pilots. This was due to the interest and voluntary participation offered by members of the targeted groups. One hundred and eight (108) responses are only sufficient to provide a moderate degree of confidence that our sample is representative of the population. In fact in order to insure a 95 percent confidence that the sample mean will not deviate greater than five percent (5 percent) from the population mean on a given question, a sample size in excess of three hundred and eighty four (384) pilots is required. The sample size of 108 will yield a confidence level of approximately 84 percent, while the sample mean deviates less than  $\pm 5$  percent from the population mean. Additionally since not all questions were answered by all respondents, an operative sample for each question is normally less than 108. The mean number of responses for the questions which are adaptable to statistical representation is 94. Thus, if a maximum five percent deviation from the population mean is desired, the greatest confidence that the sample can yield is approximately 80 percent.

Sample size alone is probably the least detractor to the statistical relevance of the survey data, since confidence intervals in excess of 80

percent can provide a valid description of the general population. This assumes that the sample is selected at random, and as discussed previously in Section 2, the selection process was not random. Reliance on volunteers, and the a priori selection of survey candidates may have biased the survey to a degree, which unfortunately cannot be measured.

The unmeasured bias introduced by the survey selection process, coupled with the relatively small sample size, makes it difficult to assign exact statistical relevance to the survey data presented in this section. To the extent possible, survey data will be compared with what is known of the civil helicopter population. Where large discrepancies between the sample data and known population data (such as pilot/aircraft census) are apparent, and biases which account for all or some of these discrepancies are known or suspected, a probable explanation is offered, as well as the authors' judgment of the impact of the bias on the validity of the survey data. It will be left to the reader to judge the impact of those biases on the conclusions presented in Section 4.

#### FLIGHT HOUR/ACCIDENT RATE LIMITATIONS (Reference 9)

In addition to the survey data limitations, there is a significant suspected limitation in the accident rate data reported by the NTSB. This limitation is due to how operators respond to FAA surveys and the resulting inaccuracies in flight hours. Accident rates are based on the number of accidents per flight hour or per 100,000 flight hours.

Before 1977 the FAA required aircraft owners to annually revalidate aircraft registrations and requested the owner to provide certain information at that time. The FAA used that data to estimate active aircraft and flight hours; and a good estimate resulted. However, in 1977, a decision was made to sample only a small percentage of the fleet through a confidential "mail-in" questionnaire. This was intended to reduce paperwork burden on operators...but the burden only shifted. The result was insufficient and inaccurate flight hour estimates.

For instance, out of the Bell Model 212 fleet in 1980 and 1981, of 141 and 144 aircraft, respectively, questionnaires were sent on only 16 and 18 aircraft for the two years, and the FAA received responses on only nine and six aircraft those years, respectively! (Since individual responses are confidential, it is unknown what type of operations responded.)

When the FAA estimates the number of active aircraft from the responses, it then uses that base to determine active aircraft fleet flight hours. Small errors in either category can compound each other, or even cancel each other out, due to the small sample size. And, the smaller the sample size, the more likely to result in larger significant errors. The accident rate can fluctuate 100 percent if sampled operations are not typical. For example, corporate aircraft will not accumulate



nearly as many flight hours as those used for offshore personnel transportation that regularly log twice the hours of operation. Accidents per flight hours can appear to be DOUBLED, just due to this one factor!

A study was conducted on each United States registered Bell Model 212 type helicopter to determine actual flight hours for each year since delivery. The FAA estimates appeared to be higher than actuals through the 1970s, and the NTSB/FAA flight hours closely followed the actual flight hours from 1976 through 1980.

However, in 1981, the FAA's flight hour estimate was only 29,309 flight hours; compared with actual flight hours of 106,937. The estimate of flight hours was 73 percent too low and the resulting rate of 6.82 accidents per 100,000 flying hours was 364 percent higher than actual experience!

After this discovery, the Bell Model 206 series was checked; the helicopter that accounts for 44 percent of all rotorcraft flight hours. (Per NTSB-AAS-81, Review of Rotorcraft Accidents 1977-1979). Since Allison Gas Turbines maintains excellent flight hour records on the engines in the 206 series, Bell was able to compare them to the published FAA statistics. The FAA flight hour estimates were 22.7 percent too low for 1981, resulting in an assumed accident rate that was 29.3 percent higher than actual. The Bell Model 222 flight hour estimate by the FAA was found to be 35 percent too low.

The FAA estimating problem is not due to poor mathematical technique. The problem is due to the assumptions caused by the selection method of sampled aircraft and significant numbers of "non-responses" to its survey.

In summary, it appears that flight hour inaccuracies caused by insufficient reporting could result in accident rates 29 percent (or more) higher than actual based on the Bell models studied. The magnitude of potential flight hour and accident rate errors on helicopters of other manufacturers is unknown. However, it is expected that the same types of errors are present for other manufacturers. Similarly the representativeness and accuracy of fixed-wing flight hours/accident rates are not known. This data limitation could not be resolved as a part of this study. However, it is important to recognize and keep it in mind while reviewing those sections of this report (primarily 3.2, 3.3) which discuss and compare accident rates. As with the survey data limitations, it will be left to the reader to judge and/or disregard the validity of the accident rate comparisons discussed.

### 3.1 PILOT SURVEY

This section will discuss helicopter pilot profiles and perspectives related to rotorcraft hazards as constructed from data collected by the helicopter operations hazard survey. The "Helicopter Operations Survey" was distributed to several National and Regional Helicopter Associations and Councils as described Section 2.0, and in Appendix A. Of the 300 questionnaires distributed, 108 were completed and returned. The Data compiled from the surveys were analyzed and, where possible, normalized to the population for easier comparison to other statistical measures. The survey objective was to solicit candid responses from professional pilots operating in the National Airspace System (NAS). This was necessary for two reasons: First, to profile these helicopter pilots and analyze the issues these pilots perceive to be hazardous to helicopter operations. Second, to define "Root Causes" and underlying reasons for helicopter accidents.

Before attempting to profile the surveyed pilots in terms of age, experience, equipment flown, etc., it is useful to compare the sample to the helicopter population as a whole with respect to distribution of operator types. This provides a rough measure of confidence that the sample is representative of the general population. Reference 10, "The 1984 Helicopter Annual," (HAI) characterize, the active U.S. civil helicopter fleet as being comprised of three (3) major operator groups. They are:

- A. Corporate/Executive
- B. Commercial
- C. Civil Government (Public Service)

Of 108 questionnaires received and analyzed in the survey, it was determined that the pilots were employed by 50 different helicopter operators. The 50 operator groups were compared to the distribution of U.S. civil helicopter operators, as described by Reference 10. The results of this comparison are shown in Figure 3.1. As can be seen, the sample is in close accordance with the U.S. civil fleet, with respect to composition by the three groups.

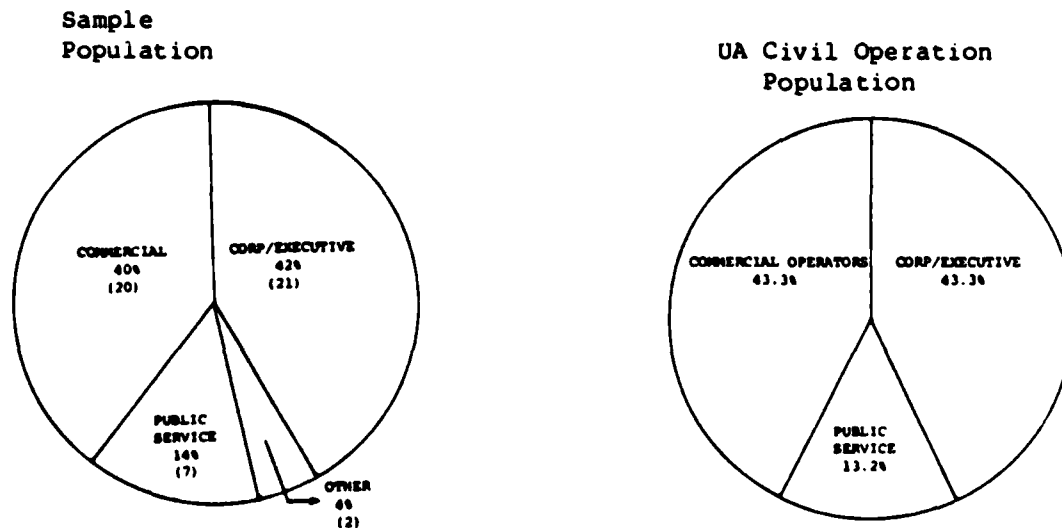

Figure 3.1 Comparison of Sample Population to Distribution of U.S. Civil Helicopter Operators

The sample was further examined to determine whether the surveyed pilots were broadly representative of the active pilot population with respect to employment in the various operator groups (corporate/executive commercial and civil government). A direct measure of the distribution of pilots within those three categories was not available since pilot certification does not place pilots in those categories, nor do insurance records indicate in what type operation a pilot is involved. Moreover, pilots, unlike the aircraft they fly and the operators who hire them, are far less static with respect to movement between operator groups. However; it is possible to estimate the distribution of U.S. civil helicopter pilots within the operator groups as a function of the quantities of aircraft employed by each group. Assuming a crew factor of 1.2 pilots per helicopter (Reference 4) for a particular operator, one would expect to find 66.2 percent of the surveyed pilots to be involved in commercial operations; 19.5 percent involved in corporate/executive operations and the remaining 14.4 percent involved in civil government/public service. In fact, the sample consisted of 58.4 percent commercial pilots, 25 percent corporate/executive, 14.8 percent civil government pilots and the remaining 1.8 percent involved in personal flying or scheduled airlines.

The preceding measures provide a degree of confidence that the respondents were representative of the population. In the following sections the individual respondents shall be analyzed to determine the degree to which they may be considered representative of the population at large.

### 3.1.1 Surveyed Pilot Census

As a barometer for its validity, the census data provided by respondents to the survey were compared initially to what was known of the pilot population. That comparison is shown in Table 3.1.

It is clear from Table 3.1 that the sample is not representative of the population as a whole, as that population is reported in References 11 & 12. However, it must be noted that discrepancies exist in the methodologies employed in compiling the airmen certification data which are presented in Reference 12. The primary source of airmen data discrepancies can be attributed to overlap between U.S. military airmen data and data for civil only helicopter pilots. For many years, the military services and the U.S. Army in particular, have been the primary training ground for civilian helicopter pilots. Shortly after completion of their initial entry rotary wing training, significant numbers of these pilots apply for and receive FAA airmen certificates. Their only requirement being that they provide proof of their military experience and pass a minimum competency written exam consisting of 40 multiple choice questions. The certificate awarded in the vast majority of cases is a commercial-instrument-rotorcraft certificate. The impact that civilian certification of military pilots has on "civil" rotorcraft airmen statistics is dramatically shown in Table 3.2.

Table 3.1 Surveyed Pilot Qualification Summary

	Sample Mean	Confidence Interval*	Population Mean
ATP Certificate	60.4%	51.1-69.6%	24%
Commercial Certificate	39.6%	30.4-48.9%	70%
Instrument Rated	68.7%	59.6-77.8%	76.3%
Class I Medical	64.4%	54.9-73.4%	unknown
Age (yrs old average)	38.2	36.8-39.6	33.5

NOTE: \*Depending on the type of distribution function, the value of other parameters of the distribution the number of items involved etc., the value of the sample mean may fall near the value of the population mean. However, the chances of finding a sample exactly equal to the population mean are very small. Therefore, the confidence interval is defined which is predicted to contain the population mean.

Table 3.2 Percent of Civil Helicopter Pilot Certificates Awarded to Military Pilots

Year	Total Rotorcraft Certificates Issued	% of Certificates to Active Military Pilots
1969	unknown	91.2
1970	unknown	95.7
1971	unknown	95.9
1972	unknown	92.4
1973	unknown	not available
1974	unknown	75.4
1975	unknown	64.6
1976	unknown	61.4
1977	1272	55.7
1978	1409	57.0
1979	1583	64.0
1980	1993	67.1
1981	2297	66.7
1982	2586	59.0

As can be clearly seen, even in recent years when Vietnam era military pilot training was curtailed, a very significant percentage of civilian helicopter pilot licenses have been awarded to active military helicopter pilots. During the period from 1977 to 1982, over 6,900 certificates were awarded to active military pilots, from a total of slightly over 11,000 total civil helicopter tickets issued during the period. During the Vietnam war, when U.S. Army helicopter pilot training was at its peak, training over 7,000 pilots per year, over 90 percent of all civil helicopter licenses were issued to military pilots. During the entire period, 1969 to 1982, the average annual percentage of certificates issued to military pilots was nearly 75 percent.

If military pilots immediately departed active military service to join the civilian helicopter industry, the impact of their civilian ratings would not unduely bias the composition and airmen characteristics of the fleet. However, they do not immediately leave service, since they must all (barring administrative or medical removal) fulfill a three year service obligation commencing upon completion of their initial rotary wing training. Another factor has the effect of delaying entry of these military pilots into the civil fleet. That factor is flight hour requirements placed upon applicants by operators who desire to keep their insurance (and maintenance) costs in check. The normal minimum crew requirement for the offshore operators, who are the greatest single employment source for all helicopter pilots, is 750 hours as pilot. Since a military pilot will receive a total of 250 hours of helicopter flight time during qualification training, and an additional 110 hours (on average) per year flight time, a military pilot must normally fly a total of five years in the military to attain the 750 hour goal, and be, in effect, employable.

It should not be inferred from the preceding discussion that the only military pilots who apply for civil helicopter certificates are those with intentions of using them at some point in the future. For many pilots with the sole desire to remain in the military service, the FAA certificate provides a backup in the event the dream of a 20 year retirement begins to fade. These pilots may or may not be current in helicopters but are maintained in the FAA records as current since they have a current flight physical, that flight physical being performed annually by a military flight surgeon who is also authorized to perform FAA medical exams.

To quantify the impact that military pilots bearing civilian licenses have on civil helicopter airmen statistics is beyond the scope of the investigation at hand, although it should be considered a fertile field for further study. It is possible, however, to surmise the impact on the civil helicopter pilot population with respect to rough measures of that population such as size of the population, age, qualifications, experience, and so forth. In the following paragraphs those effects are briefly outlined, albeit without empirical justification.

Pilot Age - according to recent statistics compiled by the Insured Aircraft Title Service, the average age of this civil helicopter pilot is 33.5 years. Since military pilots normally enter flight training between the ages of 18 and 24 years and must fly a total of six years, (including rotary wing initial training), those same pilots cannot enter the civil fleet prior to ages 24-30. If 60 percent (from the Table 3.2) of the pilots between the age of 18-24 are removed from the rolls, and assumed to enter the civil fleet six years later, the action will have the effect of aging the airmen by approximately one year, to about 34.4 years. This indicates that although the actual average age of civil helicopter pilots may not be as old as the 38.2 years of the survey sample, neither is it as young as the 33.5 years reported in Reference 12.

Qualification:

It was mentioned earlier that military pilots normally receive a commercial-rotorcraft and instrument-rotorcraft certificate upon successful completion of the military competency exam. This may account for the extremely high percentage (70 percent) of pilots in the population with the commercial certificate vis-a-vis airline transport pilot certificate. While an ATP certificate does not materially improve a military pilots employability while he is in the service, for a civil pilot it is a door to increased earnings in the fashion of advanced degrees in other professional fields. An active civil pilot is far more likely to incur the expenses for that rating than is a military pilot. If all active military, and military only pilots (such as reservists and national guardsmen) were removed from the FAA records, those records would necessarily show an increase, perhaps a very large one, in the percentage of ATP pilots, at the expense of the percentage of commercial certificate holders.

Conversely, such an action would have very negative affects on the percentage of instrument rated helicopter pilots, as currently profiled using FAA airmen records. Since all military pilots must maintain instrument proficiency, the number of instrument rated civil pilots would be reduced on nearly a one-to-one ratio to the number of military pilots on record. This is potentially the most disturbing impact that inclusion of the military pilots has, since it perturbs the data to indicate a higher degree of instrument flight experience than can actually be mustered by the civil operators. During a period when the helicopter community is taking rightful pride in the fact that both pilots and manufacturers are meeting the instrument challenge, it would cause some consternation were it found that increases in instrument qualification among airmen was due primarily to the bias of military aviation statistics.

### Flight Experience:

Where military pilots tend to increase the apparent qualifications of the civil airmen, their inclusion in the civil airmen data base should have the effect of reducing flight experience averages of the civil pilots. As discussed previously, active military aviators, because of costs and other job demands, rarely fly more than 200 hours per year (wartime combat experience excepted). In fact the minimum annual flying requirement for a FAC-1 (Flight Activity Code-1), ARL1 (Aviator Readiness Level-1) pilot in the U.S. Army is only 96 hours per year, of which up to 24 hours may be performed in a synthetic flight training simulator. FAC-2 aviators need only fly a total of 60 hours annually in aircraft and simulators to maintain minimum proficiency. Compared to civil operators engaged in commerce with their helicopters, these totals are paltry. Table 3.3 summarizes the experience levels indicated by the Hazard Survey sample, and the population at large. As can be seen, the Hazard Survey Sample exhibits far greater "recent time" averages than the population at large, by nearly a five-to-one ratio (based upon 1981 data - 2.68M hrs/29.2K active pilots). A better means exists, however, to determine recent (annual) flight time for active civil pilots. Using a crew factor of 1.2 pilots per helicopter (from Reference 4) it can be shown that a more reasonable figure of 351 hours per pilot is obtained. This value for the population mean falls within the confidence interval of the survey sample with a confidence level of 95 percent.

Table 3.3 Pilot Experience Summary (Surveyed Pilots)

Experience	Corporate/ Executive	Commercial	Civil Government
ATP Certificate	50%	66%	35%
Commercial Certificate	50%	33%	65%
Instrument Rating	55%	77%	35%
Class I Medical	61%	66%	50%
Average Age	38 yrs	38 yrs	42 yrs
Average Total Flight Time	6103 hrs	6536 hrs	6362 hrs
Average Annual Flight Time	389 hrs	487 hrs	498 hrs
Average Time in Type	1350 hrs	900 hrs	959 hrs
Average Hours Last 90 Days	93 hrs	108 hrs	66 hrs

Since data were not immediately available regarding time in type, total time, and flight hours during the previous 90 days for the civil helicopter population at large, no immediate comparison between the population and sample was made. If flying time in the last year is used as a barometer, then it can be assumed that those times in question (total time, last 90 days, and time in type) for the population would be consistent with a pilot flying about 350 hours per year.

Based upon the interpretations of data discussed previously, it is our conclusion that the sample polled, despite limitations in the selection methodology, is a reasonable representation of the body of pilots engaged in civil helicopter operations, as opposed to a representation of all pilots holding a current rotorcraft airmen certificate. It is that former group of pilots in whom the survey is interested since they contribute to civil helicopter accidents. These pilots may be characterized as having sufficient training to perform their day to day missions, and having sufficient helicopter experience to warrant a conclusion that they are familiar with the helicopters in which they fly.

### 3.1.2 Types of Helicopters Operated by Surveyed Pilots

While the survey sample is representative in terms of pilot qualifications, it is unrepresentative in terms of the types of helicopters they operate. The U.S. civil fleet in 1983 was comprised of nearly 7400 active helicopters, of which 55 percent are powered by reciprocating engines (Reference 10). Of the sample, only six of the pilots surveyed indicated that they primarily flew a reciprocating engine powered helicopter. Furthermore, none of the pilots surveyed indicated that they flew the Bell-47, the model which represents more than half of the piston engined fleet.

The cause of the discrepancy can be explained. The majority of piston powered helicopters are used in either public service, private operations, instructional training or aerial applications. As stated previously, the sample is well correlated with the population with respect to the type of operator they represent, and that like the population, approximately 40 percent of the sample was comprised of commercial operators. However within that gross categorization it is obvious that pilots engaged in offshore operations are dominant, at the expense of representation from aerial application, charter, sightseeing and other "for hire" operations. Over 73 percent of the commercial pilots surveyed were engaged in offshore operations. It is readily acknowledged that offshore operations require powerplant reliability standards beyond those that can be met by piston engines. Thus the over-representation of offshore operators within the commercial operator group, is primarily responsible for the inadequate representation of piston helicopters in the sample and biases the results toward turbine helicopter hazards and problems.



This deficiency does not necessarily undermine the conclusions and findings of this investigation because NTSB accident and incident data sources were used to supplement the survey in the area of piston helicopter accidents. Root causes are not, by definition, specific to any aircraft type, but rather to all equipment, which in this case, are rotorcraft. Root causes, if they are correctly defined, must apply to all helicopter types, albeit in varying degrees for each. (It should be noted that aerial application operations were excluded from this survey due to the uniqueness of the mission demands and the many previous studies which have treated the associated problems and hazards.)

The survey sample was representative of the turbine helicopter fleet, which represents 45 percent of the current active fleet. This group deserves particular attention since it is comprised of both 2nd and 3rd generation helicopters, which are rapidly replacing the 1st generation piston powered helicopters. In fact, during the period 1977 to 1982 the size of the turbine fleet doubled. During this same five year period, the piston fleet was shrinking at the rate of 1.8 percent annually (Reference 13). According to the February 1985 FAA forecasts, piston helicopters will comprise just 19 percent of the fleet by 1996 and could be reduced to 0 percent by 2006.

As would be expected, the Bell 206 accounts for the majority of helicopters flown by the sample pilots. 40 of the 108 pilots who responded indicated that the helicopter which they primarily flew is either a Bell 206B, 206L1 or 206L3. The model 206 represents over 37 percent of the civil turbine helicopters manufactured in the United States, and over 47 percent of the total active turbine helicopters operated in the United States.

Table 3.4 provides a summary of the fleet characteristics of the aircraft flown by the survey group, and what is known of the entire civil fleet. Table 3.4 shows that with respect to composition of the turbine fleet, the sample is somewhat representative of the population.

#### Avionics Equipage

The survey group indicated an extremely high percentage of turbine helicopters equipped and certified for Instrument Flight Rules (IFR) flight. Of 108 responses, nearly half, 49 percent stated that the helicopter they primarily flew was so equipped. In a survey performed for NASA (Reference 14), Bell Textron reported that of 200 operators surveyed, 46 percent reported that their helicopters were equipped, certified and presently operate in Instrument Meteorological Conditions (IMC) (Reference 14). It should be noted that the Bell survey did include operators who are located outside the United States, particularly in Canada and the North Sea. North Sea operations are characterized by frequent IFR flight and high percentage of IFR equipped helicopters. The Bell data is therefore probably somewhat high in their estimate of the percentage of IFR equipped rotorcraft. Likewise, in this survey the disproportionate sample of offshore pilots, (37 percent of the total sample) has the tendency of inflating projections of IFR equipage vis-a-vis the population at large.

Table 3.4 Summary of Helicopters Flown by the Survey Group

AIRCRAFT MAKE & MODEL	PERCENT of SAMPLE	% OF U.S. CIVIL HELICOPTERS
<b>PISTON**</b>		
Hughes 269	5%	9.0%
Sikorsky S-58	*	1.5%
Enstrom 280C	*	1.6%
Robinson R-22	*	2.7%
<b>TURBINE</b>		
Bell 206 (All models)	40%	25%
Sikorsky S-76	25%	2%
Bell 212	10%	2%
Bell 222	6%	*
Aerospatiale AS 355	4%	2%
Hughes 500	3%	*
BO 105	2%	*
Bell 205	2%	3%
Bell 412	*	*
BK 117	*	*
AS 350	*	3%
SA 341G	*	*

\*Less than one percent.

\*\*The absence of Bell-47's should be noted. This was due to the nine primary subjects specified in the contract and the volunteer nature of the data collection.

Significant differences exist between each of the surveyed operator groups' avionics equipage, even though nearly all of the aircraft are turbine powered. Table 3.5 shows the percentage of IFR certified aircraft for each of the three operator groups and offshore helicopters. It is readily seen that corporate executive aircraft demonstrate a markedly increased rate of IFR certified aircraft over any other segment of the rotorcraft fleet, followed by offshore aircraft, commercial and civil government. The TCAS operator survey (Reference 15) performed by SCT showed that the tendency to purchase a particular model of aircraft or avionics suite could be predicted based upon mission requirements, and that with the exception of corporate-executive operators, the operators purchased the minimum equipment necessary to perform a specified mission. Table 3.6 shows the relationship of equipment purchases to the capabilities those purchases presented, from the TCAS survey. The table clearly shows that corporate operators spent nearly twice as much money as was necessary to outfit their helicopters for IFR flight. Offshore pilots, on the other hand, spent only slightly more than was deemed necessary to perform the offshore mission. At the opposite end of the scale, civil government operators spent an amount nearly identical to that required to purchase the basic day-night VFR capability.

Table 3.5 IFR Equipage of the Survey Sample by Operator Group

<u>OPERATOR GROUP</u>	<u>% IFR EQUIPPED &amp; CERTIFIED</u>
Corporate/Executive	83%
Offshore	63%
Commercial	25%
Civil Government	0%

Table 3.6 Typical Avionics Expenditures per Aircraft  
By Operator Group

	<u>Minimum</u>	<u>Mean</u>	<u>Maximum</u>	<u>VFR</u> <u>(Day)</u> \$5256	<u>VFR</u> <u>(Night)</u> \$11,095	<u>IFR</u> \$19,052	<u>Offshore</u> \$31,092
Public Service	\$2,640	\$11,094	\$20,158	X	X		
Commercial	\$5,256	\$16,979	\$34,584	X	X		
Corporate	\$10,573	\$38,760	\$145,212	X	X	X	X
Offshore	\$10,790	\$34,466	\$56,973	X	X	X	X

These data indicate that for corporate operators, equipment purchases are not necessarily a function of mission requirements. In fact several corporate-executive pilots mentioned, in onsite discussions, that although they flew IFR helicopters, company policy discouraged IFR flight. The primary reason cited in each case was not wanting to expose high paid key personnel to the discomfort and potential hazards of IMC flight.

### 3.1.3 Survey Pilots' Operating Environment

In 1980, the most recent year for which detailed NTSB rotorcraft accident statistics are available, helicopter pilots compiled an accident rate of 13.91 accidents per 100,000 aircraft hours flown (Reference 2). During that same period, general aviation fixed-wing accidents occurred at a rate of 9.47 accidents per 100,000 aircraft hours flown. The difference between the accident rates for the two types of aircraft are even more significant when one considers that almost 30 percent of all fixed-wing aircraft hours flown are accumulated by private pilots, with

considerably less flight experience than rotary wing pilots. By comparison, less than five percent of all rotorcraft hours flown are by private rotorcraft pilots. Yet the rotorcraft accident rate exceeds the general aviation fixed-wing rate by more than 46 percent.

In order to understand this disparity, it is necessary as a first step to understand the nature of helicopter operations and the environment in which they operate. The hazard survey polled the sample pilots concerning environmental and operational factors which affect their operations. Areas of particular interest regarding the respondent's operations were:

- 1) Length of average mission
- 2) Number of takeoffs/landings per mission
- 3) Percent of flight time per phase of flight
- 4) Operating altitudes
- 5) Types of landing areas

Responses to these questions provide general descriptors of the conditions under which helicopter operations occur. In the following paragraphs, these operating and environmental conditions are discussed with respect to the hazards which they impose on helicopter operations.

#### Duration and Number of Landings per Mission

It is well known that a typical helicopter flight entails a greater number of takeoffs and landings per flight hour than a corresponding general aviation fixed-wing flight hour. In order to quantify that difference, the survey polled helicopter pilots to determine the duration of a typical helicopter mission that they fly, and the number of takeoff and landings performed in that typical mission. Table 3.7 presents the responses to those questions.

Table 3.7 Survey Sample Flight Mission Duration and Landing Frequency

	Mission Duration # Landings* (Mins)		Landing/ Flight Hours	Flight Duration (Min)
Civil Government	97.8	2.83	1.74	34
Commercial	117.70	5.06	2.61	23
Corp/Exec	69.50	3.71	3.21	19
All Helicopter	102.3	4.5	2.69	22
-----				
Fixed-wing General Aviation	90.0	1.0	.667	90

\*Note: Each landing does not necessarily constitute an engine shutdown.

It is readily apparent from these data that helicopter operations manifest significantly higher numbers of landings and takeoffs per flight hour than their fixed-wing counterparts. In fact, it can be determined that the average sortie length (the period of time between takeoff and touchdown) is just slightly less than 23 minutes for a typical helicopter flight, compared to a sortie length of approximately 90 minutes for general aviation fixed-wing aircraft. It has been reported that over 84 percent of all pilot error helicopter accidents (Part 135 helicopter operators) occur during the takeoff, approach and landing phases of flight (Reference 16). Thus, the takeoff, approach and landing phases of flight, and the conditions which characterize them are of vital importance to understanding the root causes of a significant portion of helicopter accidents.

#### Percent of Flight Time Per Phase of Flight

The survey sample was polled to determine the percent of flight time that they normally spend in each of four phases of flight. As might be expected, the vast majority (83 percent) of operations are conducted in the cruise phase, with the hover mode representing approximately five percent of all flight time. The remaining 13 percent of flight time is split nearly evenly between the takeoff and landing phases of flight time. It should be noted that very little difference was reported by pilots from each of the various operating groups, although offshore pilots indicated a greater percent of flight time in the cruise phase.

The NTSB reported that the majority of all (fixed and rotor wing) accidents (58.2 percent) occurred in the cruise phase of flight, with over 36 percent in the takeoff and landing phase. The exposure data (phase of flight) reported above, coupled with the NTSB accident statistics shows that the takeoff and landing phase have associated with them a significantly higher accident rate than other phases of flight. Several diverse factors impact the high accident rate and pilot error accident rates associated with the takeoff, approach and landing phases of helicopter flight. A summary of the most significant factors are provided below:

- 1) Obstacles/terrain
- 2) Visibility
- 3) Powerplant requirements (mostly takeoff)
- 4) Meteorology

The helicopter's utility is derived from its ability to takeoff and land from either a prepared landing surface, or an unprepared remote site, with little more surface area than is necessary to contain its length and rotor diameter. In order to maximize its utility, operators must be prepared to operate the craft in areas and locales inaccessible to fixed-wing aircraft. Helicopters are therefore exposed to hazards, such as trees, wires, blowing rocks, dust, buildings and other obstacles not normally concomitant with fixed-wing landings. Once on the ground at such a landing site, the helicopter remains exposed to other hazards such as natural debris and vegetation, F.O.D. and swampy or sloping landing

surfaces. Because no statistics are readily available from which the distribution of landings (improved and unimproved or remote landing sites) may be determined, it is virtually impossible to determine the impact that landings at remote sites have on helicopter accident statistics. However, during the year 1980, nine takeoff and landing accidents were recorded in which collisions with terrain or obstacles were a factor. An additional six accidents were recorded in which pilot vision was restricted because rotorwash induced blowing snow. Finally, 16 accidents were recorded in which unsuitable landing surfaces (muddy, sloped) caused the helicopter to roll. It is safe to assume that without the environmental conditions described, the accidents would not have occurred. The accidents described account for 12 percent of all helicopter accidents in 1980.

The extent to which pilots themselves perceive that obstacles are a hindrance to takeoffs, approaches and landings was measured by the survey. Pilots were asked to rank order a list of restrictions to their desired (hypothetical) approach direction. Figure 3.2 illustrates their ordering of the available choices. It can be clearly seen that obstacles present the most prevalent restriction to landing direction, being cited first by the 56 of 105 pilots. That response was twice as frequent as the next most prevalent restriction to the pilots preferred landing direction, noise abatement procedures.

Obstacles do not by themselves represent "root causes" of helicopter accidents. Similarly, remote sites are not a "root cause" of helicopter accidents. Rather, obstacles and remote sites provide a venue in which the capabilities of both the pilot and his aircraft are tested. The NTSB posts the results of those tests in the Annual Review of Aircraft Accident Data. In Section 3.2, the findings of the NTSB review shall be discussed. Those findings report how the aircraft or pilot failed. The discussion shall focus on the root causes of those accidents - "why" the aircraft/pilot failed.

#### Helicopter Operating Altitudes

It is generally accepted that helicopters operate at lower altitudes than fixed-wing aircraft. The survey sought to determine both what those altitudes were, and why they operated there. Table 3.8 presents the summary of pilot responses to the question "indicate the percent of time that you operate at each of the following altitudes".

Figure 3.2 Pilot Ranking of Restrictions to Approach Directions  
(Assuming Favorable Wind Direction)

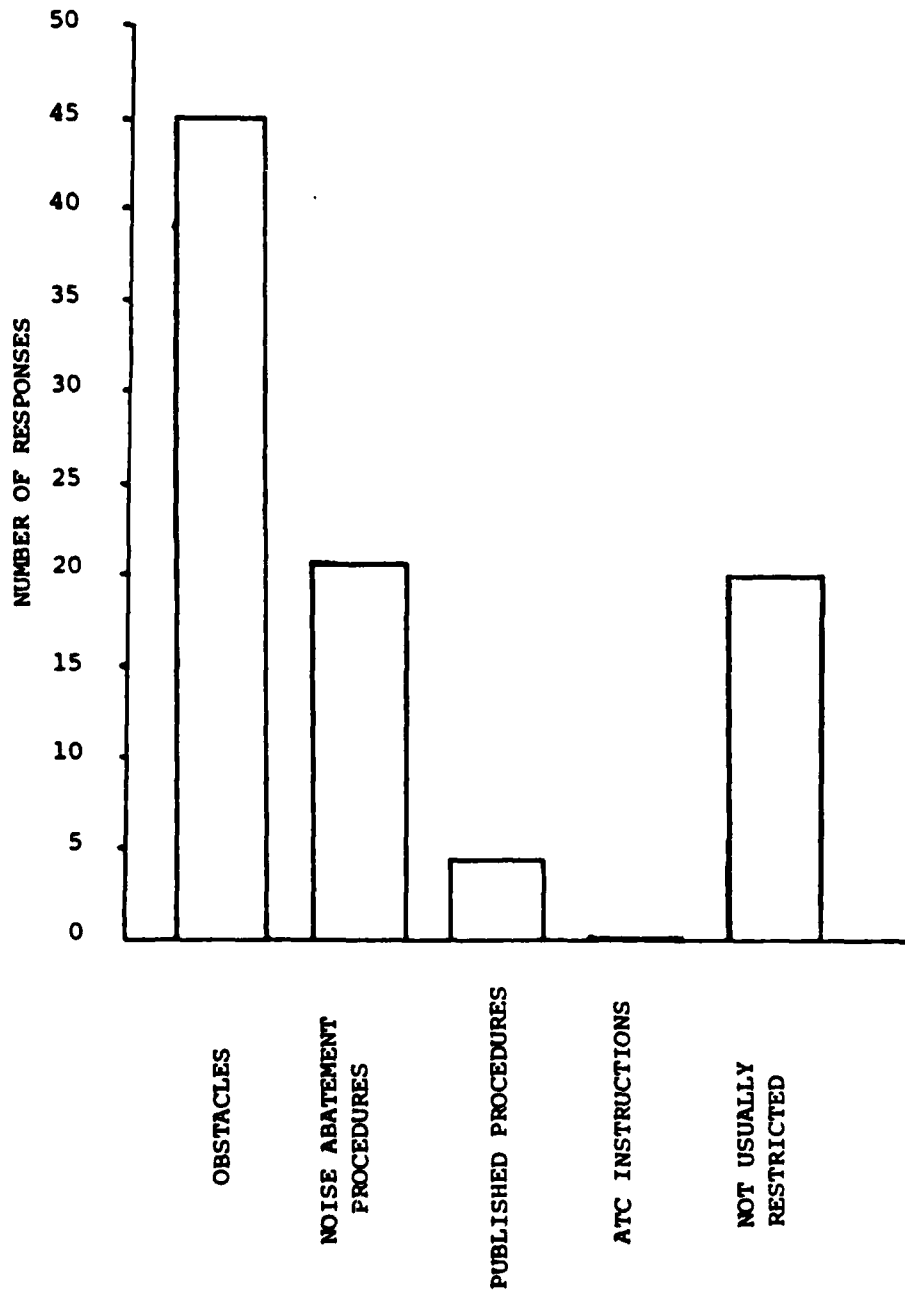

Table 3.8 Survey Sample Helicopter Operating Altitudes

Altitude (AGL)	Percent of Time at Altitude
0-100 ft	5.2%
100-500 ft	11.3%
500-1000 ft	37.8%
1000-1500 ft	18.8%
1500-2000 ft	9.0%
2000-3000 ft	8.4%
> 3000 ft	9.4%

As can be seen, the pilots indicated that over half (54 percent) of their operations are conducted at altitudes of less than 1000 feet, with only 17 percent at altitudes (above 2000 ft) which might be considered to be part of the low altitude enroute structure. These findings are in concert with those of the TCAS operator survey (Reference 15), in which mean operating altitudes for each of the operator groups were determined. Those findings are shown in Table 3.9.

Table 3.9 Mean Operating Altitudes by Operator Group (Reference 15)

Operator Group	Operating Altitude (AGL)
Civil Government	785 ft
Commercial	863 ft
Corporate	1203 ft
Offshore	1553 ft

As discussed previously, the survey sample did not include aerial application operators. Had they been included, the mean operating altitude of commercial operators would be reduced, since they normally operate at extremely low level. Similarly, the absence of this segment of operators limits the analysis and conclusions to only the nonaerial applications type of flying.

Obviously some of the pilots fly at low level because their mission requires that they do. Such missions as surveillance (civil government), and construction, aerial application and geological survey (commercial) can best be performed at lower altitudes. However, there do not appear to be compelling mission requirements that force offshore and corporate operators to the lower altitudes. In discussions with the various operator groups, the following reasons were repeatedly offered:



- o Pilots desire to use traffic free airspace as much as possible to minimize possibilities of mid-air-collisions.
- o Pilots do not want to be controlled by ATC since the system does not facilitate the unique capability of the helicopter.
- o Pilots desire to stay close to the ground in the event of a catastrophic transmission failure. (This is a subjective opinion not substantiated by accident data).
- o Non-IFR helicopters take advantage of low altitudes to perform special VFR penetrations of control zones.
- o Average sortie length is approximately 20 miles and/or 22 minutes which would preclude going to normal cruise altitude.
- o Pilots desire to fly VFR to minimize delays encountered with the National Airspace System.

Surprisingly few pilots stated that they only flew low when forced to by low ceilings. In fact, a large number of pilots stated that they continued to fly low, despite increased ceilings and visibility. The impact of pilot's selection of low altitudes for their operations is discussed in Section 3.2.

### 3.2 ANALYSIS OF HAZARDS OF HELICOPTER OPERATIONS AND ACCIDENT CAUSES

The National Transportation Safety Board, in the Annual Review of Aircraft Accident Data - U.S. General Aviation - Calendar Year 1980, (Reference 2) reported that during 1980, helicopters and helicopter pilots were involved in a total of 263 aircraft accidents, for an all cause accident rate of 13.91 accidents per 100,000 aircraft hours flown. This rate represents the continuation of the downward trend in helicopter accident rates since 1975, as shown in Table 3.10.

Table 3.10 Helicopter Accident Rates, 1975-1980 (Reference 2)

Year	Hours Flown	Accident Rates Per 100,000 Hrs Flown	
		Total Rate	Fatal Rate
1975	974,000	27.31	1.85
1976	1,103,000	22.57	2.36
1977	1,170,000	21.11	1.88
1978	1,397,000	20.40	2.93
1979	1,522,000	17.54	2.30
1980	1,891,000	13.91	2.12

In addition to providing the annual accident rate data for both piston and turbine powered helicopters, the NTSB report also lists, in order of frequency of occurrence, the "most prevalent detailed accident causes" for the two classes of rotorcraft. Table 3.11 provides a synopsis of those detailed causes.

Table 3.11 Most Prevalent Detailed Helicopter Accident Causes - 1980

DETAILED CAUSE	TURBINE ACCIDENTS		PISTON ACCIDENTS		ALL ACCIDENTS	
	Number	Percent	Number	Percent	Number	Percent
Misc Acts, Conditions- Material Failure	8	10.0	22	12.0	30	11.4
Pilot-Inadequate Preflight Prep and/or Planning	10	12.5	19	10.4	29	11.0
Powerplant-Misc-Failure for Undetermined Reasons	8	10.0	20	10.9	28	10.6
Pilot-Failed to Maintain Rotor RPM	3	3.8	16	8.7	19	7.2
Pilot-Failed to See and Avoid Objects or Obstructions	5	6.3	12	6.6	17	6.5
Pilot-Misjudged Clearance	5	6.3	11	6.0	16	6.1
Personnel-Inadequate Maint and Inspection	4	5.0	12	6.6	16	6.1
Pilot-Improper Operation of Flight Controls	2	2.5	12	6.6	14	5.3
Pilot-Mismanagement of Fuel	5	6.3	9	4.9	14	5.3
Misc Acts, Conditions- Fuel Exhaustion	5	6.3	9	4.9	14	5.3

It is interesting to note the degree to which each of the detailed causes contributes to the accident rate of each of the classes of rotorcraft. The percent contribution of each of the detailed causes for both turbine and piston helicopters is the same order of magnitude, although all of the causes occurred with greater frequency in piston helicopters. That is, a like percentage of the overall accident rates for piston and turbine helicopters is attributed to the same causes, but the accident rate for each of the causes is still much higher for piston helicopters than for turbines.

The equivalence in the percentage contribution of the most prevalent detailed causes of turbine and piston helicopter accidents was not anticipated. One would expect that because of the major differences in powerplant, drive train, airframe and instrumentation of the two classes, differences in pilot characteristics and mission profiles, some causes would emerge as predominant for each of the two types. This was not the case. To further investigate the apparent correlation, a comparison was made of the most detailed accident causes which were attributed to most general aviation fixed-wing accidents. Obviously, some causes of fixed-wing accidents, are by their nature appropos only to that class of aircraft and cannot be compared to rotorcraft causes. Conversely, some causes which appear to be fixed-wing specific, have a rotary wing corollary. An example of this detailed cause is "Pilot-Failed to Obtain/Maintain Flying Speed" which has a rotary wing corollary of "Pilot-Failed to Maintain Adequate Rotor RPM". Table 3.12 presents a comparison of the contribution of each of the causes (in which an appropriate FW-RW comparison can be made) to their corresponding accident rates.

Correlation coefficients were computed (Correlation coefficients were calculated as the covariance between the two variables divided by the square root of the product of the variances (covariance (x,y) /  $s_x s_y$ ) for combined pilot and material caused accidents, and for pilot error only accidents. For the combined statistics, a correlation factor of +.23 was computed, indicating that very little correlation between causes of fixed-wing and rotary wing accidents. However, when accidents clearly attributable to material failure were removed from the data base, the correlation coefficient improved to +.81. This would seem to indicate that a high degree of correlation exists between causes of airplane and helicopter pilot error accidents. This would also indicate that the commonality is a result of a human problem rather than a material or manufacture problem. There is no intuitive rationale which would explain why such a correlation might exist, since aircraft and pilot, mission profiles and operating environments are significantly different for both classes of aircraft. It would appear, therefore, that some factor has an influence on either the pilots, or on the accident data itself, which forces the correlation.

Table 3.12 Comparison of Detailed Causes, FW-RW

FIXED-WING DETAILED CAUSE	FW PERCENT OF ACCIDENTS	RW PERCENT OF ACCIDENTS
Pilot-Inadequate Preflight Prep/Plan	11.6	11.0
Pilot-Failed to Maintain/Obtain Flying Speed*	10.4	7.2
Pilot-Mismanagement of Fuel	7.4	5.3
Misc Act. Conditions-Fuel Exhaustion	6.5	5.3
Powerplant-Misc-Failure, Undetermined	6.0	10.6
Misc Acts, Conditions, Material Failure	4.9	11.4
Pilot-Misjudged Distance & Speed**	4.8	6.1
Pilot-Failed to Maintain Directional Control***	4.1	5.3

\* "Pilot-Failed to Maintain Rotor RPM"

\*\* "Pilot-Misjudged Clearance"

\*\*\* "Pilot-Improper Operation of Flight Controls"

One hypothesis for this correlation is that given a random sampling of pilots (both fixed-wing and helicopter) a like percentage of fixed-wing and helicopter pilots will demonstrate a proclivity to be involved in pilot error accidents. Furthermore, those airplane and helicopter pilots would be each as likely to react to various situations in manners which would produce similar types of accidents. However, if this hypothesis was true, one would expect that the rate of pilot error accidents for each type of aircraft would be nearly the same (for similar most prevalent detailed causes). This is not the case, since only the percent contribution of pilot error (most prevalent detailed causes) to the total accident rate is similar for the two types. (38 percent of fixed-wing rate versus 34 percent of rotary wing rate.)

A more probable (but yet untested) hypothesis is that the unifying factor which causes the apparent correlation between airplane and helicopter pilot error accidents is that the classification of accidents by cause is performed by a single agency, whose expertise in accident investigation has been largely gained through investigations of fixed-wing accidents. It is possible that when a helicopter accident is investigated, the investigator brings with him a framework of assumptions, training and experience which is biased from fixed-wing investigations. The effect of this circumstance would be an inherent forcing of the investigator's conclusions to fit his experience in fixed-wing accidents. If this is the case and it does occur, it may hamper efforts to explore, beyond the most basic cause and effect relationships, the causes of helicopter accidents.

Neither of the two hypotheses will be tested within the scope of this study. The latter hypothesis should be examined and tested, since it is from NTSB accident data that operators, instructors, and in some cases manufacturers develop their safety awareness and design programs. If the data they use in developing the programs is influenced by a fixed-wing perspective or is unrealistically inflated, real causes may be masked and therefore not targeted for remedial action.

A cursory examination of the list of "most prevalent detailed causes" of helicopter accidents tells the reader very little about the chain of events which culminated in the accident. Since one must know why an accident occurred in order to identify its root causes, the detailed causes are examined in the following section. For the purposes of this investigation, four of the most prevalent detailed accident cause categories will be studied in depth, with special emphasis placed on engine failure accidents. These four accident causes are:

- o Pilot-Inadequate Preflight Preparation and/or Planning
- o Powerplant-Misc-Failure for Undetermined Reasons
- o Pilot-Failed to Maintain Adequate Rotor RPM
- o Pilot-Failed to See and Avoid Objects or Obstructions

In addition to these four "detailed accident causes", 79 accidents which are classified by the NTSB as engine failure malfunctions are examined. Emphasis is placed on the analysis of the 79 engine failure/malfunction accidents reported in 1980, since it allows discussion of the hazards associated with autorotation, and also includes the discussion of three other related "most prevalent accident causes" - Pilot-mismanagement of fuel; Miscellaneous Acts, Conditions - Material Failure; and Miscellaneous Acts, Conditions - Fuel Exhaustion. Root causes for these three accident cause categories are presented with those of "Powerplant - Miscellaneous Failure for Undetermined Reasons".

Likewise, two of the remaining accident cause categories are inextricably related to other categories which will be discussed in detail. These two are "Pilot-Improper Operation of the Flight Controls" (discussed with causes of autorotation accidents), and "Pilot-Misjudged Clearance" which shares several of the same root causes as "Failed to See and Avoid Objects or Obstructions".

In the following sections, an analysis of the four major accident cause categories is presented. The analysis focuses on the root causes for these, and other accident cause categories, and provides suggestions for remedial action to those causes.

### 3.2.1 Pilot-Inadequate Preflight Preparation and/or Planning (Reference 2)

This detailed cause of helicopter accidents accounted for 29 separate accidents, or 11 percent of the total accidents during 1980. Of these 29 accidents, only six occurred in turbine rotorcraft. The type of aircraft and frequency of occurrence for the 29 accidents are presented below:

<u>Aircraft Type</u>	<u>Frequency of Occurrence</u>
Bell 47 Series	9
Hiller H-12	6
Hughes 369	4
SA 315	3
SA 318*	
Bell H-13	2
Bell 206 Series*	2
Bell UH-1B*	1
Boeing Vertol H-21	1
Fairchild	1
Total	<u>29</u>

\*indicates turbine powered helicopter

Since turbine powered aircraft account for over 36 percent of the fleet, and a greater percentage of helicopter hours flown, the low percentage (20 percent) of accidents in turbines is of interest. This is particularly true since of all the detailed causes, the "pilot-inadequate preflight..." cause is most indicative of a human, rather than an equipment failure. To determine whether or not pilot experience or certification could account for the discrepancy, a comparison was made between the qualifications and experience of the piston and turbine pilots. There were no significant differences in the basic qualifications of the pilots of either class of helicopter. Table 3.13 presents a summary of the pilots' qualifications.

Table 3.13 Pilot Qualification Summary - 1980 "Pilot-Inadequate Preflight Accidents" (Reference 2)

	<u>Turbine</u>	<u>Piston</u>
Pilot Certification	Commercial - 5	Commercial - 12
	Commercial-CFI - 1	Commercial-CFI - 6
		Air Transport-CFI - 2
		Private - 3
	<u>6</u>	<u>23</u>
Total Time Type	358	423.6
Total Time Type (last 90 days)	160.9	98.85
Total Time	3611	3253
Total Time (last 90 days)	162.1	152.9

One significant difference did exist in the pilot experience of the pilots of the two types of helicopters. That difference is in the ratio of hours flown in type (last 90 days) versus the total hours flown in the previous 90 days. Whereas, the turbine pilots exhibited a ratio of near 1:1 (.99), the piston pilots had a ratio of 1:1.54, (.65), indicating that nearly one-third of their flying was performed in an aircraft other than the aircraft in which they had the accident. This routine crossover between aircraft types facilitates the accident causes of regression and habit transfer. For example, the piston helicopter pilot will undoubtedly be much more familiar with the "weak links" and typical preflight problem areas for the aircraft he flies 65 percent of the time. The typical problems and even the preflight procedures for other piston helicopters will be different.

Since inadequate flight planning is a major contributor to the high helicopter accident rate, the responses of the survey pilots to questions pertaining to preflight planning are of great interest. The pilots were asked several questions regarding their procedures and preferences

regarding this pilot task. The first question was "How many actual working hours are available between first notice of, and the scheduled departure time for your primary mission?". The pilots were provided a range of six possible responses to the question. The average time available for pilots in each of the three major operator groups is provided in Table 3.14.

Table 3.14 Survey Results: Available Flight Preparation Time  
(by Operator Group)

<u>Operator Group</u>	PERCENT < 1/2 hr	PERCENT < 1 hr
Commercial	39	72
Corp/Exec	11	19
Civil Government	46	77

It is clear that for the majority of pilots, little advanced warning is given for a particular mission, although the corporate/executive pilots would appear to have far more planning time than their counterparts in the other two operator groups since 81 percent indicated they had more than one hour planning time. That same group, (corporate executive pilots) also committed the fewest inadequate planning/preflight errors which resulted in accidents. Of the 29 accidents in 1980, only two involved aircraft engaged in executive transportation. The rate of accidents due to inadequate planning for corp/exec operations is also the lowest of all groups, at 0.21 accidents/100,000 operations, compared to a rate of 1.53/100,000 operations for all rotorcraft. In addition, the analysis showed that corporate/executive turbine and piston accident rates were nearly identical (0.85 and 0.82 accidents/100,000 hours, respectively.) Since corporate pilots can achieve comparable accident rates with piston and turbine helicopters, it would appear that flight planning/preparation could reduce piston accident rates overall.

Obviously some factor other than the type of mission, pilot qualifications or aircraft type accounts for the low incidence of corp/exec inadequate planning accidents. It is quite possible that element is the increased planning time available to corporate executive pilots.



Another factor which might influence the low incidence of such accidents is the manner in which the available planning and/or preparation time is utilized. Two questions were asked of the surveyed pilots which gauge their utilization of the available time. The first question presented a hypothetical situation in which the pilots were given one hours notice to depart on a 200 mile VFR flight. The pilots were given a list of 10 planning/preparation tasks. Each task had associated with it a fixed completion time, sum for all tasks being one hour and 47 minutes. From this task list, the pilots were to indicate and prioritize the tasks which they would perform in the one hour available to them. The pilot responses to this question are shown in Table 3.15.

Table 3.15 Survey Results: Time Allocation During Performance of Preflight Tasks (by Operator Group)

TASK	TIME (mins)	OPERATOR GROUP			
		CORP/EXEC	CIVIL/ GOVT	COMMERCIAL	
Check Weather	5	100%	100%	85%	} Percent of pilots in each group who would perform each task
Check Notams	5	96%	100%	58%	
Plan Route	20	89%	86%	77%	
Prepare Weight & Balance	20	93%	86%	60%	
Performance Planning*	15	89%	79%	47%	
Prepare/File Flight Plan	5	89%	86%	60%	
Preflight Inspection	25	100%	100%	79%	
Ground Runup Checks	5	93%	100%	83%	
IGE Hover Checks	2	82%	79%	52%	
OGE Hover Check	5	100%	93%	40%	

\*Planning speeds, fuel consumption, altitudes, etc. compatible with density altitude and climb/descent profiles.

The results shown in Table 3.15 are startling, indicating that the commercial pilots, as a group, are far less diligent in their performance of preflight planning and preparation tasks. This result is especially surprising since a substantial number of the commercial pilots are engaged in offshore operations, as employees of major helicopter operators. It is generally considered that these operators have standardized operational procedures which are strictly adhered to by the pilot. The pilot supplied data and the accident data do not support this assumption.

A surprising omission on the part of the commercial operators is seen in the low incidence of selection of two flight planning tasks: 1) performance planning, 2) in ground effects (IGE) hover checks and performance planning for out of ground effects (OGE) hover performance. This is surprising since the commercial pilots reported the greatest percentage of flight missions in which their aircraft was operated in excess of 90 percent of maximum gross weight.

Commercial pilots reported that they flew in excess of 88 percent of all their flight missions in aircraft loaded to more than 90 percent of maximum gross weight, while 42 percent of corporate executive and 48 percent of civil government pilots operate under the same condition. Since the weight of the helicopter, particularly at high gross weights, is a significant contributor to the performance of the craft, and is a contributing factor to loss of tail rotor control, settling with power, loss of rpm and retreating blade stall, and numerous other adverse conditions, one would expect that such indicators of performance as are afforded by those two checks would be of some interest to pilots operating in high gross weight conditions. Again, this is not substantiated by the survey data. Furthermore, the survey data tend to predict a high incidence of gross weight related inadequate planning accidents which are discussed in Section 3.2.1.1 Root Causes -- Pilot Inadequate Preflight and/or Planning.

In addition to asking the survey pilots which flight planning tasks they would perform for the hypothetical 200 mile flight, they were asked to indicate their probable course of action if they determined that the time available was insufficient to perform all of the preflight tasks. The pilots were given two options: 1) Perform the most necessary tasks and make the scheduled departure, and 2) Inform the dispatcher that you cannot make the scheduled departure, and perform all of the preflight tasks. The group response for this question was approximately four-to-one in favor of the first option; to make the scheduled departure. No comparisons may be made to corporate/exec, civil government operators, or piston operator responses, since an insufficient number of them responded to the question to place any degree of statistical significance on the response.

Pilots were allowed to make comments regarding their selections and prioritization of their preflight preparation tasks. The commercial pilots took full advantage of the opportunity to provide rationale for their choices. In light of the abbreviated flight planning task lists they created, those comments appear almost to be alibis. A few of the most frequently repeated comments are:

"Flights are repeated day after day ... pilot is able to compute almost instantly fuel required ..."

"Weight and balance takes one-to-two minutes to figure"

"All tasks may be performed in much less than one hour.."

"Can meet all demands..."

"Preflight completed before sunrise"

"Aircraft is always ready"

"What is OGE?"

In fairness to the survey group, (which is comprised of a significant proportion of offshore pilots) many of the tasks could have been performed prior to the receipt of the flight mission. In fact for many types of operations, such as offshore and E.M.S., some preflight tasks must be performed before a mission is assigned. If this is the case, then all of the tasks could have been performed within the one hour allotted to do so. The pilots, however, did not take advantage of that available time, but relied instead on past experience and company procedures to insure that the flight was adequately prepared. Over reliance on canned flight plans, weight and balance, and performance planning may in fact be a cause/factor of several of the "pilot-inadequate planning/preflight inspection" accidents. A pilot who routinely operates in the Gulf of Mexico with gross weight conditions at about 95 percent of maximum gross weight, and in temperature ranging from 85F to 95F could very quickly find himself out of left anti-torque pedal in a slightly fast or steep approach, with an outside air temperature of 102. Full input of the anti-torque peddle may not provide adequate compensation for the torque resulting from the excessive power required at the bottom of the steep or fast approach profile. The important point is that even in operations where the mission is fairly constant in nature, conditions arise in which the aircraft's performance limits are tested. To be best prepared for that inevitable eventuality, pilots must take advantage of all available time to perform complete and accurate preflight inspections and planning. At the very least, a concentrated effort could be made to streamline and expedite the flight planning process before each days mission. This thought is well summarized by a pilot respondent, a maintenance pilot for a major offshore operator. He too commented regarding his selection of the preflight tasks he would perform for the same hypothetical mission. His comment was:

"(I would) plan an additional 40 mins for the preflight procedures. Safety in the air starts on the ground with proper preflight procedures. A pilot cannot fly ahead of his aircraft safely when he takes off ill prepared and already behind the aircraft. Coupled with the environment, a pilot cannot make up the lost preflight ground (time) and still expect a safe flight on a regular basis."

The "pilot-inadequate preflight" accident is most often the result of fuel exhaustion. Nearly half (45 percent) of the 29 accidents in this category occurred because the pilot ran out of fuel. The next most common cause was misloading the aircraft. Seven of twenty-nine accidents were the result of this cause. A complete cause summary of the "pilot-inadequate preflight" accidents is presented in Table 3.16.

Table 3.16 Detailed Cause - Pilot-Inadequate Preflight Accidents, 1980

Cause	Number of Occurrences
Fuel Exhaustion	13
Density Altitude	3
Overgross	4
Unsecured external equipment	6
Icing	2
Insufficient Information	1

There is no single factor which can explain why properly certified and experienced pilots run out of fuel. It is improbable that these pilots were unaware of the fuel requirements/limitations of the helicopters in which they were flying, or uncaring of the consequences which must follow from fuel exhaustion. Therefore one must assume that the pilots failed to use good judgement in planning the mission in question for causes external to his training. These causes, are by their nature, the root causes of the subject accidents since they are descriptive of the basic behavioral influences which resulted in the accidents.

It is not possible to assign a frequency or even a specific root cause to any of the accidents in question since the complete records of the accident investigation, including pilot interviews, were not available at the time of writing. However, based on the narrative provided in the accident briefs, it is possible to hypothesize the root causes of this family of accidents.

### 3.2.1.1 Root Causes - Pilot Inadequate Preflight Preparation and/or Planning

#### Fuel Management

Five of the 13 fuel exhaustion accidents were attributed to pilots engaged in aerial application flying. That mission is particularly demanding, inasmuch as the pilot must simultaneously perform several flight tasks: maintenance of altitude within tolerance of  $\pm$  one foot, maintenance of airspeed, monitoring of dispensing/spraying equipment, and preparation for, and performance of, his procedure turnaround. In some instances, it is possible that over attention to these flight tasks results in lack of attention to another - fuel management. Also, they make spray runs and refill fuel and spray at the same time. Sometimes they don't fill up. A point to consider is the extreme aircraft roll change at the end of each run. This could cause fuel sloshing and the uncovering of the fuel inlet in low fuel cases.

- o Pilot ran out of fuel due to impaired judgement.

Another possible cause for the fuel exhaustion accidents is impaired judgement. That judgement may be impaired by a number of diverse factors, as follows:

- o workload too high
- o fatigue
- o overconfidence in self
- o overconfidence in equipment
- o pressure of perceived economic necessity
- o get-home-itis

All of these factors have a similar result when applied to the flight planning and preflight inspection tasks associated with helicopter flight. That result is the omission of critical tasks, or the cursory completion of those tasks. When these pressures are brought to bear on the pilot performing the tasks, a pilot will frequently draw on previous experience to fill in the gaps left by his omissions. An example of this is seen when a pilot says "I usually have enough fuel after spraying 200 acres to return to the refuel point, so I have enough fuel to spray 200 acres this time...". Substitution of experience for an actual check of fuel requirements and available fuel will eventually result in fuel exhaustion.

Next to fuel exhaustion, the most common subcategory of "pilot-inadequate planning/preflight preparation" accidents involves pilots who attempted to lift off without removing tiedowns, or with unsecured external equipment.

### Inadequate Preflight Inspection

In 1980, five accidents resulted from these failures, all of which might have been easily avoided had the pilots performed more adequate inspections. In one case, a pilot attempted to takeoff with towbars attached to the skid tubes. In another, a pilot failed to untie his rear skid from a landing platform. In both cases, had the pilot even looked, he would have noted the problem and could have corrected it before taking off. Such accidents are, unfortunately, bound to continue so long as helicopter pilots remain human. There is little that manufacturers can do to prevent such failures, short of placing sensors throughout the helicopter, monitoring their status, and if conditions so dictate, providing the means to prevent the pilot from taking off (or starting the engine, or engaging the clutch...).

The incidence of such accidents is low by comparison to the overall rate, and as such, should not be the focus of any intensive safety enhancement effort. The elimination of these pilot error accidents will only occur when pilots use greater care in performing their preflight planning and inspections, and when the conditions which reduce the care with which these tasks are conducted, are eliminated.

### Inadequate Monitoring of External Loads

Three accidents were caused as a result of entanglement of unstowed and/or unprepared external loading equipment. In one case, a pilot took off with an external load, a fertilizer bucket, which became caught on the loading system, and pulled the helicopter to the ground. In another case, the external load sling became misrouted over the top-of-the helicopter skid. The shift in the lateral center of gravity when the pilot tried to takeoff caused the helicopter to roll to its side and crash. The last accident in this group occurred when a pilot took off dragging an unsecured external load strap. The strap became caught on a ground cable, causing a rapid deceleration and crash of the helicopter.

Each of the preceding three accidents could have been avoided had the pilot visually checked to insure that the external equipment had been properly secured. However, in many cases, it is impractical for the pilot to check the equipment, if this requires that he get out of the aircraft to do so. It is true that during most external load operations, a ground crew will hook up the equipment, and provide signals to the pilot to indicate whether the load is ready to be lifted. Unfortunately, ground crews are susceptible to the same factors which decrease pilot performance, and as such cannot be 100 percent reliable 100 percent of the time. The pilot should therefore have a means to monitor the external load, independent of the ground crews observation and judgement. Some, although not all, helicopters engaged in external load operations are

equipped with mirrors mounted so that the pilot may observe the load. In those aircraft not equipped, the pilot has no means to insure that he can make a safe takeoff. Thus, a root cause of some accidents may be stated:

- o Pilot could not visually monitor an external load.

This particular root cause can be mitigated fairly simply, through the employment of wide angle viewing mirrors. These kits have been available for many years, and have served pilots using them well. The distortion caused by the wide viewing angle is cited by several pilots as a reason for not using them. Other monitoring schemes employing fiber optics or television cameras could provide the pilot with a means to observe the external load without the distortion of wide angle mirrors. In any event, providing the means to observe the load is no guarantee that pilots will use the information. This is especially true if the attachment cable is hooked over the top of the skid.

#### Inadequate Performance Planning

The next most common subcategory of "pilot-inadequate planning/preflight inspection" accidents concerned pilots overloading or misloading their helicopters. Seven accidents are attributed to this shortcoming, according to the 1980 NTSB accident review. In one case, pilot attempted to takeoff with his aircraft weight in excess of the maximum allowable takeoff weight, and with the center of gravity forward of the most forward CG limit. The accident resulted because insufficient aft cyclic input could be made to raise the nose of the helicopter to decelerate. A more common manifestation of the overload condition occurred when coupled with a high density altitude condition. In this situation the density altitude exceeded the hover "service ceiling" of the helicopter and the power required to sustain lift and safely operate the helicopter exceeded the output of both the rotors and engine.

As discussed earlier, performance planning, hover checks, and weight and balance planning are the most frequently ignored preflight planning tasks (Table 3.14). It is not surprising, therefore, that so many gross weight/density altitude accidents occur. The human error elements of these accidents remains the same as the root causes described earlier. However, other root causes are evidenced by this type of accident. Probably the most prevalent cause is that some helicopters are inadequate for the job in which they are used. Commercial operators in particular must squeeze the maximum economic value out of their aircraft, which may force the employment of the helicopters in missions for which they are only marginally suited. The high cost involved in stepping up to more capable class of helicopters must be born by either increased utilization

rates or higher price for the services. Since most customers are not willing to pay the differential to have the same job performed by a more modern helicopter, operators, particularly those on tight budgets, are forced by economic necessity to continue providing services with less capable equipment.

Another root cause associated with density altitude accidents is insufficient power, and insufficient tail rotor thrust. These two root causes, while contributing to "pilot-inadequate planning..." accidents are more properly classified as causes of powerplant, RPM, and loss of control accidents. As such, these root causes will be discussed in more detail in Sections 3.2.2 and 3.2.3.

#### Encounters With Icing Conditions

The final group of accidents which was distilled from the list of "pilot-inadequate planning/preflight inspection" accidents involved encounters with icing conditions. Two accidents fall into this category. In one case a pilot was forced down while flying in rain (during VFR conditions) due to airframe and rotor icing. The second accident occurred when a pilot took off in VFR conditions in a helicopter with snow and ice accumulations on both the fuselage and rotors. The pilot was unable to adjust the throttle and made a crash landing as a result. The throttle linkage was found to be completely frozen.

In both accidents, it can be said that a prudent pilot would not have taken off under the conditions the accident pilot did (raining, mountain flying, mid spring season). This combination of conditions should have been a warning signal to the pilot, whether or not weather reports were available, with adequate icing information, at the time of the flight. As such, a finding of pilot error is probably a legitimate conclusion in this case. However, in the first accident, a contributing cause might have been the unavailability of weather reports, or the lack within the weather reports of icing information.

#### 3.2.1.2 Summary of Root Causes of "Pilot-Inadequate Planning/Preflight Inspection Accidents.

As noted, this cause category of helicopter accidents accounts for more than 11 percent of all helicopter accidents, making it a potentially lucrative target for efforts designed to reduce the overall helicopter accident rate. Initial efforts should be focused on standardizing and streamlining the preflight/planning process so that it can be done easier and more quickly without sacrificing effectiveness. However, since most of the root causes which influence this type of accidents are related to basic pilot behavior, they may be among the most difficult accident types to eliminate. Table 3.17 presents a summary of root causes for these accidents, as well as means by which these accidents may be mitigated.



Table 3.17 Summary of Root Causes "Pilot Inadequate Preflight Preparation and/or Planning" Accidents

System Failure	How Failed	Why Failed (Root Causes)	Remedies
Pilot	Failed to insure sufficient fuel	Impaired judgement Fatigue Overconfidence in self Overconfidence in aircraft Pressure of perceived economic necessity Get-home-itis Complacency	Incorporate of decision making Training into required student pilot curriculum Develop company crew rest policy which accommodate the varying nature of helicopter operations/enforce policies Improved pilot training Improved pilot training "By the Book" operations "By the Book" operations More frequent recurrency training in-house pilot evaluations/decision making training
Pilot	Ignored Low Fuel Warning Light	get-home-itis Pilot Mistrust of Fuel Gauges Overconfidence in self Overconfidence in aircraft	"By the Book" operations Improve Fuel gauge design/fuel low warning systems Improved pilot training Improved pilot training
Pilot	Did not conduct preflight inspection	Impaired judgement Fatigue Overconfidence in self Overconfidence in aircraft Pressure of Perceived economic necessity Get-home-itis Complacency	Introduce decision making training to pilot training curriculum Develop & enforce crew rest policies Improved pilot training Improved pilot training "By the Book" operations "By the Book" operations More frequent recurrency training in house pilot evaluations

Table 3.17 Summary of Root Causes "Pilot Inadequate Preflight Preparation and/or Planning" Accidents (Continued)

System Failure	How Failed	Why Failed (Root Causes)	Remedies
Pilot	Inadequate monitoring of external loads	Pilot could not visually monitor external load Pilot did not monitor external load	Develop improved optical and/or electronic load monitoring equipment for external load operations "By the Book" operations
Pilot	Inadequate Performance Planning (Icing encounters/high density altitude	Impaired judgement WX information not available Icing Density Altitude	As discussed previously Provide weather dissemination through Data links, or other means to remote sites Improve aircraft icing predicaction capabilities Expand density altitude reporting to airfields/heliports below 2000 ft. MSL Include density altitude reports/warnings in all pilot/tower initial contacts, ATIS instructions, etc.

### 3.2.2 Powerplant-Misc-Failure for Undetermined Reasons

Next to pilot-inadequate planning/preflight inspection accidents, powerplant failure for undetermined reasons is the most common cause for helicopter accidents which occurred in 1980. Twenty-nine (29) accidents are cited by the NTSB as being attributed to that most prevalent detailed cause. This represents an accident rate of 1.53 accidents per 100,000 flying hours, and as such represents a significant part of the civil helicopter accident rate problem. Table 3.18 shows a comparison of piston and turbine accident rates, as well as the rates for general aviation fixed-wing.

Table 3.18 Comparison of Powerplant Failure-Undetermined Cause  
Accident Rates - FW/RW (1980)

	Rotary Wing	Fixed-Wing
Turbine	.683/100,000	.072/100,000
Piston	2.78/100,000	.633/100,000
All	1.53/100,000	.568/100,000

It is evident that helicopters of both powerplant types suffer higher failure rates than fixed-wing aircraft with similar engines. It is axiomatic, but not necessarily true, that the helicopters suffer significantly higher powerplant failure rates than do corresponding fixed-wing aircraft because helicopters operate in a far more hostile flight environment than do the airplanes. A review the accident briefs of all 79 accidents in which the cause was known or undetermined, revealed that only two engine failures were the result of Foreign Object Damage (FOD), and an additional three accidents in which FOD is suspected to have contributed to the engine failure. Even supposing that the three accidents were in fact FOD induced, this still represents less than seven percent of all rotorcraft engine failure accidents and is insufficient to explain the large disparity between powerplant failure rates of the two classes of aircraft. However, a different type of "hostile environment" is caused by routinely operating helicopter engines at or near maximum power for a large percentage of the time. Also, helicopter engines have many power fluctuations per flight hour whereas fixed-wing engines do not.

It is difficult to make comparisons of the true engine failure rate of the two classes of aircraft since, engine failures which culminate in a successful dead-stick (fixed-wing) or autorotational (helicopter) landing are almost never reported, even as incidents to the FAA. A comparison can be made of the severity of the accidents resulting from engine failures of both aircraft types, by comparing the degree of injury of occupants in the accident aircraft, Table 3.19 shows that comparison.

Table 3.19 Comparison of Degree of Injury of Engine Failure Accidents - FW/RW (1980)

	% Fatal	% Serious	% Minor	% None
Fixed-Wing (Engine Failure)	9.2	16.1	20.2	54.4
Rotary Wing (Engine Failure)	4.0	13.9	20.2	62.0
All Fixed-Wing	17.7	10.3	13.7	58.3
All Rotary Wing	15.2	12.9	20.5	51.4

If it were true that fixed-wing engine failures were less catastrophic in their consequences than rotary wing engine failures, one would expect to find fewer serious injuries associated with those accidents. This is not the case, in fact, just the opposite is true. For engine failures there were less fatalities in rotary winged aircraft. This appears to be related to the low speed terminations of a rotorcraft autorotation. Other factors have a bearing on the degree of injury sustained by occupants of the accident aircraft, such as crashworthiness of the aircraft, cabin design, restraint systems, etc. If degree of injury is an indication of crashworthiness, it would seem that airplanes are as a group no more crashworthy than helicopters. Of 3236 total airplane accidents in 1980, 28 percent resulted in fatal or serious injury to crew/passengers, while 72 percent of the accidents had only minor or no injuries. An identical percentage (28 percent) of helicopter accidents during the period resulted in fatalities or serious injuries.

The more probable cause of the high rate of helicopter powerplant failures is that the helicopter engine experiences an accelerated "life cycle" compared to a similar engine placed in a fixed-wing aircraft. Remember that the typical helicopter mission profile involves a takeoff and landing every 22 minutes an average, compared to every 1 1/2 hours for a general aviation fixed-wing mission (see Table 3.7). During each 22 minutes phase, the pilot must make a minimum of six power changes to the engine (idle to hover, hover-takeoff, takeoff-cruise, cruise-descent, descent-hover, hover-idle). Also, in order to arrest a descent rate during hovering maneuvers will cause a very high power demand. If the power is not available, rotor rpm will bleed off. An engine is least likely to fail when it is in a steady state condition. The sheer number of changes made in helicopter power settings during a typical flight hour increases the risk of failure, since failure is a function of changing the demand on the powerplant. Furthermore wear of engine parts is also affected by the temperature and lubrication changes resulting from engine power changes.

This fact has been long recognized by engine manufacturers, who frequently state reliability (for military fighter engines as an example) as a function of mission cycles rather than flight hours. As an example, the U.S. Air Force assigns different engine cycles for differing fighter missions such as intercept and air superiority missions. If the same type of aircraft is assigned both combat roles, the engines' reliability will undergo accelerated testing against both mission cycles. The result will normally be differing Mean Time Between Failures (MTBF) and consequent TBO's for each of the two roles.

In the case of fixed-wing/rotary wing comparison, the actual cycles are essentially the same, however, helicopters complete 4.5 times as many cycles/hour as airplanes. Based upon this alone, one would expect a nominal 4.5 times greater rate of powerplant failures among helicopters than fixed-wing. A comparison of the rates of the two shows that all helicopters experience an engine failure rate of nearly three times the rate of fixed-wing. When the failure rate of piston engine failures for the two classes of aircraft are compared, the results are more revealing. Piston helicopters exhibit a rate 4.4 times as great as for similarly equipped fixed-wing aircraft. This is particularly important since the piston engines employed on helicopters are nearly identical in configuration to those employed on airplanes.

In order to further investigate the phenomenon, a comparison was made between the time spent in each phase of flight and the percentage of engine failures (of undetermined cause) which occurred during those phases of flight. The data concerning the amount of time spent in each phase was derived from the Hazard Survey Questionnaire, and as described earlier is not known to be representative of the entire fleet. It is useful as a baseline for comparison, since no other sources are easily available. Table 3.20 shows the comparison.

Table 3.20 Survey Results: Perception of Relative Risk of Engine Failure (by Phase of Flight)

Phase	% of Time Spent In Flight Phase	% Engine Failures Causing Accidents	Relative Risk (Baseline = Cruise)
Hover	10	12	2.34X
Takeoff	5	24	9.36X
Cruise	78	40	1.0X*
Approach/Land	7	24	6.69X

\*Cruise is a low power requirement phase for the engine.

By normalizing the accident data with respect to the amount of time spent in each phase of flight, it is possible to determine the relative risk of an engine failure for each phase. As is seen, the cruise phase of flight, although it has the greatest exposure (78 percent of all flight time) to the engine failure risk, evidences only 40 percent of all engine failures. It is therefore the least likely phase for an engine failure to occur that will result in an accident. This shows the effectiveness of an autorotation from the cruise phase of flight which also provides the most time available to the pilot. Conversely, the takeoff and landing phases require higher power and have the least time available. Used as a baseline to compare the risk of engine failure for the other phases of flight, it is shown that the takeoff phase is the most critical with respect to likelihood of an engine failure. A pilot might expect nine times as many engine failures during takeoff than in a similar (chronological) period of cruise flight.

These data demonstrate fairly well the relationship between power changes and engine failures, and accounts for the wide disparity in helicopter and fixed-wing powerplant failure rates. Thus a root cause of a significant number of helicopter accidents (those relating to powerplant failure) is:

- o The helicopters operational environment accelerates wear of the engine and increases the likelihood of engine failure.

The solution to this aspect of helicopter accident rates is related to technology and maintenance. Helicopter engine's must be developed with the increased durability and ruggedization requirements of helicopter operations in mind, and tested in an environment which more closely duplicates phase of helicopter flight. An interim solution while helicopter specific engines are being developed may be to adjust the TBO's and inspection cycles of helicopter engines to more closely reflect the accelerated life cycle of those engines. TBO's more closely correlated with "on-condition" maintenance could reduce engine failure rates. Obviously, this solution must be weighed against the economic impact on operators, which may be positive or negative. It is true, also, that this particular accident mode will continue to decrease with respect to impact on the overall rotorcraft accident rate as older piston helicopters are replaced by the more reliable single and multiengine turbine helicopters. Finally, whether piston or turbine, proper maintenance and operation is essential to reducing engine failures. The importance of prompt replacement of worn out parts, paying attention to chip detector lights and proper engine cool down cannot be over stressed.

The previous discussion focused on why the helicopter engines fail in the first place. The answer, accelerated life cycles imposed by their mission, largely explains that hazard. It does not explain why the accident occurred. An engine failure need not always result in an accident, since it is a fairly benign failure, leaving a pilot with complete attitudinal and directional control of the aircraft. Since this is so, a more precise question than why did the accident occur is, therefore, "Why was the pilot unable to execute a successful autorotative descent and landing?". If one accepts the premise that an engine failure does not necessitate a helicopter accident, and that the autorotative capability of the helicopter provides sufficient safe egress from that situation (except when adequate clear areas are not available), then the answer to the question must provide more "root causes" of helicopter accidents. Before answering the "why", a discussion of how the engines failed is necessary.

#### 3.2.2.1 Failure Modes - Powerplant Failure/Malfunction

Powerplant failures for undetermined reasons represented the largest group of engine failure modes, as determined by the NTSB for the flying year 1980. The next most common cause of the powerplant failures was attributed to fuel starvation. Twenty-seven (27) of 79 engine failure accidents occurred as a result of this condition. Fuel starvation is not monolithic in character, inasmuch as it can result from a multitude of failures. Table 3.21 presents a summary of the system failures which resulted in powerplant fuel starvation and a subsequent accident.

Table 3.21 Summary of Causes - Powerplant Fuel Starvation (NTSB 1980)

Cause	Frequency	Percent
Planning/Fuel Quantity	15	55.6
Fuel Contamination	6	22.2
Fuel Line Disconnected/loose	2	7.4
Fuel System	2	6.9
Fuel Dump Failure	2	7.4
Governor Failure	1	3.7
Carburetor Failure	1	3.7
Fuel Control	1	3.7
Improper Fuel Line	<u>1</u>	<u>3.7</u>
Total	27	100%

The data show rather plainly that the majority of fuel starvation accidents are the result of improper fuel planning on the part of the pilots themselves, rather than in any basic flaw in aircraft or its powerplant. In fact, this single cause is responsible for nearly 20 percent of all powerplant failure/malfunction accidents. The root causes of these types of accidents have been previously discussed in Section 3.2.1.1.

Fuel contamination is also a significant contributor to fuel starvation accidents, accounting for 22 percent of all such accidents. Of the six accidents in which fuel contamination was a cause, one accident was caused by air in the fuel line, two by dirt in the tank and closing the fuel filter and three by water in the fuel. There is a lot that pilots can do to detect fuel contamination prior to it becoming an in-flight emergency. First and foremost he should drain a sufficient quantity from the sumps and filters prior to flight such that he can visually detect the contamination. In fact in three of these instances, the pilot was cited as contributing to the accident since he did not check, or ignored the evidence of the check. However, the root cause of these accidents was the result of improper fueling equipment or procedures which produced the contamination. To reduce this hazard, manufacturers, NASA or the FAA should focus on developing technological solutions such as centrifugal fuel pumps with particle separators, contamination detection systems or other aircraft fixes.



The remaining causes of fuel starvation are attributed to installation and/or maintenance defects in the fuel system, although no obvious trend is apparent from a review of the specific defects. Two accidents were the result of loose fuel lines, one from improper fuel line installation. One instance of a loose/leaking fuel pump and one loose fuel control were also reported. Finally, one carburetor failure was also reported. If a unifying condition exists which relates the majority of these failures to one another, it is vibration encountered during helicopter flight, which are sufficient to work loose otherwise properly fastened engine accessories. Vibration is an important contributor to engine and other material failures.

Two primary causes of helicopter powerplant failures have been determined thus far: 1) pilot-planning/preflight and 2) fuel starvation. These two causes alone have resulted in 27 accidents, or 34 percent of all in-flight engine failures and 54 percent of all engine failures for which a cause has been determined (50 accidents). The remaining powerplant failures have been attributed to an assortment of various causes, with insufficient number of repeated causes from which to determine any particular trend. Table 3.22 shows a detailed listing of all sources of engine failures for which a cause has been determined.

#### 3.2.2.2 Root Causes of Powerplant Failure Accidents

As discussed previously, the occurrence of an engine or powerplant failure does not necessitate an accident. In this section, the reasons why the failure culminated in an accident will be discussed, and the root causes defined. The evaluation of engine failure accidents will include consideration of all 79 powerplant failures, rather than only the 29 whose engine failure was for an undetermined cause. This allows a significantly larger data base from which root causes can be derived, than would otherwise be afforded.

It is generally conceded that the only appropriate pilot action for a complete powerplant failure in a single engine helicopter is the establishment of an autorotative descent and preparation for a power off landing. However, not all engine failures are complete, nor is a successful (no aircraft damage) autorotation always possible. Of the 79 accidents attributed to engine malfunctions, it has been determined that in 26 of the cases, an autorotation was not the appropriate pilot action, or the probability that the pilot would have been able to successfully accomplish an autorotative landing was severely limited by other factors external to the pilot or the aircraft. This section will address those 26 accident cases. Section 3.2.2.3 will discuss the root causes of pilot

Table 3.22 Sources of Engine Failures Resulting in an Accident (1980)

Cause	Source	# of Occurrences	% of All Accidents
<u>Undetermined</u>		29	37
<u>Pilot</u>		<u>22</u>	<u>28</u>
	Pilot-Fuel Exhaustion	15	19
	Fuel Contamination	3	4
	Failed to Use Carburetor Heat	2	3
	Continued VFR in IMC (inlet icing)	1	1
	FOD (sleeping bag)	1	1
<u>Fuel System</u>		<u>16</u>	<u>21</u>
	Fuel Contamination	3	4
	Governor	2	3
	Loose/Disconnected Fuel line	2	3
	Fuel System (unspecified)	2	3
	Loose PC Airline Nut*	3	4
	Leaking Fuel Pump	1	1
	Loose Fuel Control	1	1
	Improper Fuel Line	1	1
	Stuck Carburetor Float	1	1
<u>Engine</u>		<u>8</u>	<u>10</u>
	FOD - Compressor	2	3
	Broken Connecting Rods	2	3
	Third Turbine Vane	1	1
	Turbine Blade	1	1
	Cylinder Wall	1	1
	Turbine Engine Explosion	1	1
<u>Other</u>		3	4
	Lubrication System	2	3
	Accessory Gearbox	1	1
	Unknown	<u>1</u>	<u>1</u>
		79	100

\*Two of the three failures were the result of a non-complied A.D.

error autorotation accidents which account for the remaining 53 accidents. The factors which most frequently prevented a successful autorotation in 1980 are listed as follows:

<u>Factor</u>	<u># Of Occurrences</u>
Terrain (trees, uneven ground)	6
Sling Loading Operations	7
Terrain (open water)	2
Visibility (IFR-snow)	3
(IFR-fog)	1
Banner Towing	1
Airframe Breakup	1
Autorotation not appropriate	5
Total	<u>26</u>

It is interesting that sling load operations were associated with such a high engine failure rate, nearly 9 percent of engine malfunction accidents. When compared to all 263 helicopter accidents in 1980, the twenty (20) accidents during sling loading operations, the percentage rate is nearly the same, at 7.6 percent. It is unknown exactly what percentage of total annual helicopter hours are flown in external load operations, however, it seems reasonable to believe that eight percent is excessive. If so, sling loading operations can be described as a particularly hazardous mission. This suggests that the mission itself influences the engine failure rate of the helicopters, rather than the helicopters influencing the accident rate for the particular mission. This intuitive hypothesis is born out if one accepts that accelerated engine throttle cycles, and high power demands shorten the mean time between failures (MTBF) of the engines. External load operations demonstrate both of these characteristics to a greater extent than other helicopter missions. Thus, an increased rate of powerplant failure for that mission could be expected. This condition is one element of the double hazard involved in external load operations. The second element is the high pilot workload over long periods of time coupled with operation at (or outside of) the helicopter performance limits. In some cases, the high workload may prevent pilots from observing overspeeds, over torques and over temps.

The next element compounds the problems created by the increased engine failure rate. The problem is that a helicopter engaged in external load operations which sustains an engine failure, will find its autorotational capability markedly reduced. The combination of low speed, low altitude and high angle of attack of main rotor blades make it extremely difficult to complete a successful landing in the event of an engine failure. The high angle of attack of the rotor blades, which are necessary to generate sufficient lift during a sling load operations, will cause the rotors to rapidly decelerate when the drive of the engine is lost. Even an immediate reduction of angle of attack (collective lever) is not always sufficient to bring the rotor back within acceptable autorotative RPM limits. This is especially true at low altitudes, such as a hover, where there is insufficient altitude to perform turning and decelerative maneuvers which could increase rotor speed.

Pilots engaged in sling load operations have two strikes against them thus far - increased probability of an engine failure and a reduced autorotational capability. The third strike is the load itself. The external load must be jettisoned if there is to be any probability of a successful autorotation. Unless this is accomplished immediately, it acts alternately as a pendulum, obstacle and an anchor. In any one of those roles the load can change an otherwise promising autorotation into a catastrophe. Unfortunately, it is not always possible to jettison an external load. Switch location, switch failures, emergency releases, failures and pilot/crew coordination are only a few of the reasons that the sling load is not jettisoned in time. The crew must also be mindful of ground rigging crews and avoid releasing the load when there is danger of injury to them.

Several "root causes" are discernable from an evaluation of sling load/engine failure accidents. Probably the most important concerns the basic design of the helicopter powerplants. If this mission causes an increased rate of engine failures, then the

- o Powerplant is inadequate for the task in which it is employed

A second root cause of some accidents, (at least six in 1980) is that

- o Standard emergency procedures are ineffective for some mission types/profiles

That is, a pilot may in some cases have no recourse in preventing an accident when he encounters a complete engine failure while engaging in sling load operations.

### Terrain

The ability to complete the final landing phase of a power-off landing is seriously degraded when the terrain is inhospitable. During 1980, a total of nine accidents might have been averted had the pilots had more suitable terrain on which to land. In two cases, the only landing sites available were hillsides. The approach was made uneventfully, but the landing was ruined when the helicopter rolled down the hill. Two other cases involved successful water landings in the Gulf of Mexico and the Gulf of Alaska. Both helicopters were swamped in rough seas after the landing. Five of the accidents occurred when the pilots attempted forced landings into densely wooded remote sites.

None of the above accidents were avoidable given the conditions in which the landings were forced to terminate. Unfortunately, pilots are often forced to operate in areas in which no suitable forced landing sites were available. From the first day of flight school, most pilots are taught to constantly monitor the terrain over which they are flying and to note available forced landing sites. If none are available, it is prudent

for the pilot to adjust his course so as to make them available. Some regions are not conducive to these pilots' actions, such as offshore, and in remote areas such as Appalachia, Alaska and others. So long as helicopter engines are vulnerable to failure and pilots must operate in those remote regions, terrain will remain a significant inhibitor to successful autorotations. Thus, another contributing cause of helicopter accidents is:

o Terrain inhibits successful completion of forced landings

The effects of terrain may in some circumstances be minimized if the pilot takes one simple step. He must fly at a higher altitude. Figure 3.3 shows typical autorotative glide distances for the Bell 205. As is evident, maximum glide distance increases linearly as altitude increases, and is not nearly as vertical as most non-helicopter pilots believe. For example flying at an altitude of 3,000 ft AGL a pilot who experiences an engine failure can reach a landing site up to 2.67 miles from his position, if he chooses the maximum glide airspeed distance of 98 knots. This represents a total surface area in excess of 22.4 square miles. Even using the minimum descent rate airspeed, the pilot can reach a forced landing site within a radius of 2.2 miles, which allows a surface area of 15.4 square miles in which to find a forced landing area. Contrasted with the most frequently flown altitude of the pilots who responded to the survey, the reason that terrain is an important inhibiting factor to forced landings becomes clearer. At an altitude of 500 ft AGL, the maximum glide distance is reduced to less than .45 miles, with surface area of only .62 square miles.

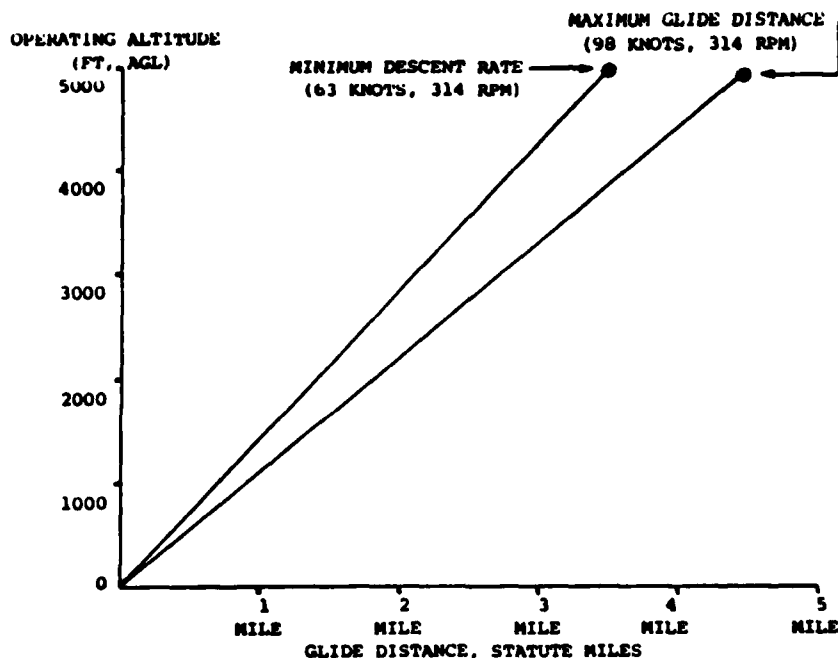

Figure 3.3 Autorotative Glide Distances, Bell 205

An increase in the operating altitude has the added advantage of enabling the pilot to plan forced landing areas farther in advance, since his slant range vision is less restricted by trees, hills and other natural and man made obstructions to vision.

Considering the added safety afforded by a higher operating altitude, a valid question is why pilots, if given the choice, select the lower one. In discussions with the surveyed pilots during the on site interviews, and with other pilots and flight instructors with an interest in the subject, several valid reasons were presented. One common rationale was that they preferred to fly at the low altitude so as to avoid mixing with general aviation pilots, who they believed represented a significant mid-air collision risk. The pilot's responses also indicated an undercurrent of mistrust of the Air Traffic Control system. That mistrust was not in the system's ability to provide separation services for their flight, but rather a product of the inefficiency in which helicopter flights were handled by the system. When asked what those inefficiencies were, the pilots cited fixed-wing traffic patterns, marginal visibility operations and holding patterns. In short, they would rather fly low and avoid the system to the greatest extent possible.

The most common and forceful response to the question of why they choose to fly at low altitude was, surprisingly, related directly to avenues of escape for in-flight emergencies. Pilots consciously choose to fly at low altitude, fully aware that that choice limits his ability to complete an autorotative landing. Low altitudes provide him with an improved margin of safety in the event of a more dangerous in-flight emergency. That emergency is failure of the transmission. Unlike an engine failure, if the transmission seizes, the pilot can do virtually nothing to prevent an accident. Moreover, a transmission failure during cruise is nearly always fatal. Pilots faced with this choice stay at low altitude since it means they can get on the ground more quickly at the first indication of incipient failure (transmission oil pressure, temperature, transmission chip detector lights, low rotor rpm). Pilots view this failure mode with far more fatalism than they do an engine failure. All helicopter pilots have had some experience with practice autorotations, and are not unduly concerned with the prospects of an engine failure. On the other hand, very few pilots experience an in-flight transmission seizure. They, therefore, elect a low altitude to decrease the possibility that the signs of an impending failure will fully develop to a transmission seizure.

It is certainly true that that particular failure mode is uncommon. During the year in question, 1980, only two were reported, and both of those at low altitudes. Despite this fact, it is a failure mode which by virtue only of its possibility, influences pilots' day to day actions.

#### Visibility Restrictions

The next major factor which inhibits the pilot's ability to complete a safe autorotation is reduced visibility. In 1980, four engine failures

occurred in conditions of reduced visibility other than night. Specifically those instances occurred two times in snowstorms, once in fog, and once in a rotorwash-induced white-out. In fact, in one case, the engine failure itself was the result of inlet icing which the pilot could have avoided had he not elected to proceed VFR in instrument meteorological conditions (IMC). It could not be determined from the accident brief whether that pilot had a clear choice or whether other factors caused him to proceed. The extent to which the meteorological conditions restricted the pilot's vision in each of the three cases was not determined. It is assumed, for the purposes of this analysis, that conditions preclude sufficient time for the pilot to see the ground and prepare his landing before he impacted. While this may not represent the true circumstances in each of the accidents, it does provide a realistic scenario in which external, meteorological conditions could prevent, or seriously degrade, the probability of a successful power off landing.

Approximately five percent (4 of 79) of all engine failure accidents occurred in limited visibility conditions. This is approximately the same ratio as the percentage of IFR flight hours to total flight hours. As more IFR equipped and certified helicopters join the fleet, and more IMC flight hours are flown, the problem will increase. Surveyed pilots are aware of this fact. When asked what their most difficult mission was, and what made the mission difficult, seven pilots stated that single engine IFR operations in the New York metropolitan area was the most difficult, and further cited a need for more multiengine turbine helicopters with improved one engine inoperative (OEI) capability.

The New York Area, although not a remote site demonstrates one major hazard similar to offshore or mountainous regions. That is, lack of suitable forced landing sites for aborted takeoffs or missed approaches. During IFR operations, an OEI capability to return or continue to a instrumented helipad is the single, best means to prevent a powerplant failure accident.

It should be noted during 1980, multiengine turbine helicopters were involved in three accidents when only one engine failed. This would seem to indicate that the level of OEI performance can be improved.

Without the development of higher reliability powerplants, and pilot visual aids which might allow him to see through meteorological restrictions to the ground, engine failures in IMC will continue to result in accidents. As IFR operations increase as a percentage of all operations, the impact of those accidents on the overall helicopter accident rates will also increase. A contributing cause of a potentially growing number of helicopter accidents is therefore

- o Meteorological restrictions to vision prevent successful execution of power-off autorotative landings.

### 3.2.2.3 Root Causes of Pilot Error Autorotation Accidents

This analysis is an attempt to determine the impact of automation on accident rates using all available and reported data. Historically, incident reporting could lead to inconsistencies which would impact the results.

During 1979, 53 accidents due to improper autorotations occurred. These 53 were not affected by any of the inhibiting factors previously described such as terrain, sling load operations, visibility, or airframe breakup. In each of these, the failure was primarily the result of an improperly executed emergency procedure-autorotation.

In order to understand the high incidence of unsuccessful autorotations evidenced by the accident records for 1980, a necessary first step is the analysis of the available pilot and aircraft data for each of the accidents. It is also beneficial to compare those data to similar data for pilots who successfully completed autorotations. Fortunately, such information is available in the form of aircraft incident reports for the same period. An incident is similar to an accident except that the degree of injury and/or aircraft damage is substantially less than for an accident. An autorotation resulting in only minor or no injuries and less than \$20,000 dollars damage to the aircraft is classified by the NTSB as an incident (Reference 2). Incident reports provide a useful foil to compare accident data. They enable the researcher to focus his study on the differences between two populations exposed to the same test, in order to determine if any fundamental differences between the two groups exist which would explain why one group failed and the other passed the test.

There are those who will disagree that comparing accident and incident data is a valid methodology, that calling an autorotation which culminates in an aircraft incident successful may overstate the result. It is certainly true that \$20,000 is no small sum, and that even minor injuries are unacceptable when none are necessary. However, in light of the large number of emergency autorotations which are unquestionably a result of engine failures, an incident is a vast improvement, if not successful, by comparison. The term successful is therefore relative only, inasmuch as those autorotations are at least not reflected in accident statistics.

During 1980, a total of 28 engine failures resulted in an autorotation and aviation incident. At least eight of those resulted in no additional damage (other than that which may have caused the engine failure initially) to the aircraft. If these 28 failures and the 79 powerplant failures which ended in accidents discussed previously were the the only powerplant failures which occurred in 1980 it would mean that an engine failure is three times more likely to result in an accident than in an incident, an alarming trend. It is difficult to accept this conclusion. An explanation for the discrepancy is that the NTSB only requires that a powerplant related incident be reported if it involves an in-flight fire



or the failure of a major turbine component, excluding compressor vanes and blades. Within those guidelines, successful emergency autorotations involving piston helicopters might not be reported. Similarly, successful emergency autorotations involving turbine helicopters, resulting from blade and vane failures or other non major turbine components might not be reported.

It is possible, however, that the twenty-eight incident autorotations do comprise a significant and representative percentage of all additional powerplant failures. If true, the incident rates provide interesting insights into the root causes of engine failure accidents. As discussed previously, piston helicopters exhibit a significantly higher engine failure rate than do turbine helicopters. These data indicate piston helicopters are also more susceptible to accidents because of those failures than are their turbine powered counterparts. That susceptibility is not entirely attributable to mechanical and aerodynamic differences between the two, but also significant differences in the experiences of the pilots who performed the autorotations. Those differences are discussed in subsequent sections of this report.

The next comparison shown in Table 3.23 focuses on the phase of flight in which the helicopter was engaged at the time of the powerplant failure. The most common phase of flight in which engine failures resulting in both accidents and incidents occurred was the cruise phase. However, whereas 25 percent of all powerplant failure accidents were initiated in the low level cruise phase, no incident engine failures were initiated in that phase. These data seem to show that each phase of flight has associated with it a relative autorotation hazard risk which is independent of either the percent of time spent in that phase or the probability of engine failure while in that phase. Table 3.23 presents the relative risk for each phase of flight, normalized to the phase of flight in which an autorotation is most likely to successfully be accomplished.

The data in Table 3.23 show dramatically that low level cruise is by far the most dangerous phase of flight with respect to unsuccessful autorotation. This is true primarily for the aerial application operations which contributed 90 percent of the data and who routinely cruise at and below 50 feet. This should come as no great surprise since low altitude cruise flight is by definition, outside the autorotational envelope of most current helicopters. For operations other than aerial applications, Table 3.23 correlates the relative risk of unsuccessful autorotations in the same order as Table 3.20 did for relative risk of engine failure. That is, takeoff has the highest risk with approach second and hover third. It is possible to predict which phases of flight would be the most hazardous with respect to engine failure by studying a height/velocity diagram for a particular aircraft. Figure 3.4 depicts a H/V diagram for a typical piston helicopter.

Table 3.23 Relative Risk of Unsuccessful Autorotation by Phase of Flight

Phase of Flight	Risk Factor
Low Level Cruise*	X
Takeoff	7.4X
Approach	3.6X
Hover	3.1X
Cruise (at altitude)	1.0

\*Over 90 percent occurred during aerial application operations at much less than 50 ft AGL.

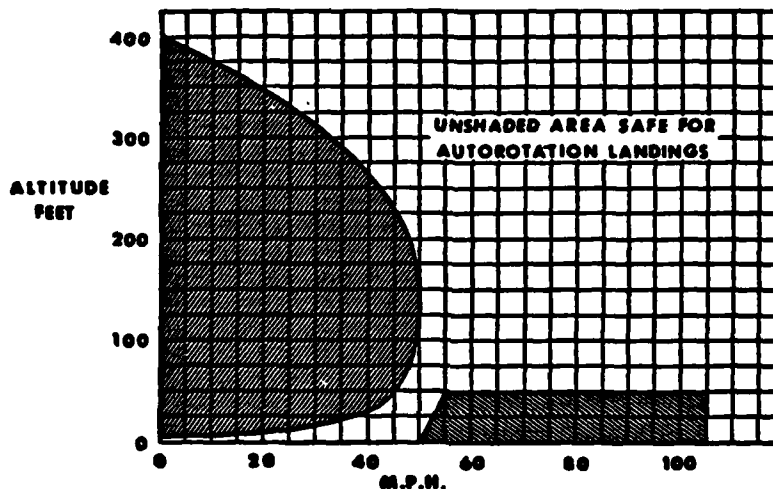

Figure 3.4 Height Velocity/Diagram - Typical Piston Helicopter

(Shaded region indicates reduced autorotational capability in the event of engine failure).

From the H/V diagram, it is shown that in the cruise phase of flight with airspeeds in excess of 50-60 knots, and an altitude of greater than 50 feet, autorotational capability is not impaired. During the low level cruise phase, with airspeeds greater than fifty knots and altitudes less than 50 feet, a successful autorotation is highly improbable since it is within the shaded "no fly" region of the chart.

The points to which the shaded regions of the height velocity diagram converge is that region where all hover, takeoff and landing phases are conducted, initiated or concluded. When operating within that region of the chart, the pilots have little margin for error if a successful autorotational landing is to be accomplished. The problems of completing an autorotation successfully are compounded when the pilots depart from normal procedure and perform nonstandard approaches and takeoffs. In many cases, such as takeoffs and landings at offshore oil platforms; some point in space approaches; and takeoffs and landings at confined areas, pilots place their aircraft within the impaired autorotational capability regions of the height velocity diagram. The hazard survey queried pilots to determine the approach profiles they most frequently fly. They were asked to select from five descent angle and airspeed options. The results of the survey are shown in Table 3.24.

Table 3.24 Most Frequently Flown Descent Angles and Approach Airspeeds

<u>Descent Angle</u>	<u>%</u>	<u>Approach Speed</u>	<u>%</u>
Very shallow	1%	Slow	6%
Shallow	11%	Moderately slow	39%
Normal	58%	Per operators manual	40%
Steep	25%	Moderately fast	15%
Very steep	5%	Fast	0%

The most frequent response to the questions was that pilots flew normal descent angles with airspeeds per the aircraft operators manual. A significant number of pilots; however, selected other than standard approach angles and airspeeds. This fact poses no particular cause for concern since the height/velocity diagram allows for safe variations from the normal approach profile. A brief look at the diagram shows that to maintain an acceptable autorotational capability, steeper approach angles may be used if higher airspeeds are flown. Conversely if "shallow" approach angle is used, slower airspeeds are required if the helicopter is to remain within the autorotational envelope. So long as these basic rules are applied, autorotational capability in the landing phase is not severely impaired by the selection of a nonstandard approach profile. Table 3.25 shows how well pilots who indicated that they fly nonstandard approach profiles comply with these rules.

Table 3.25 Pilot Approach Profiles

<u>Airspeed/ Angles</u>	<u>Slow</u>	<u>Moderately Slow</u>	<u>Operators Manual</u>	<u>Moderately Fast</u>	<u>Fast</u>
Very Shallow	-	-	-	-	-
Shallow	-	-	1%	2%	-
Normal	4%	22%	30%	12%	-
Steep	2%	7%	7%	4%	-
Very Steep	1%	2%	-	-	-

Only 30 percent of the respondents indicated that they fly a normal approach angle at the airspeed prescribed by their operators' manual. An additional 34 percent indicated that they fly a normal angle but with moderate (fast and slow) variations of airspeed. These pilots, if subjected to an engine failure during the approach, would be in an airspeed/glide angle configuration which is conducive to a successful autorotation.

70 percent of the surveyed pilots indicated that they fly an approach in a nonstandard configuration. Of these, 41 percent fly their approaches in a fashion which is both nonstandard and reduces the probability that they could successfully complete an autorotation if their engine failed (See Table 3.24). (It has been determined previously that the risk of engine failure is increased during the approach phase of flight (from Table 3.23)).

The pilot responses are, of course, subjective, and there is no quantitative data to empirically determine their true approach profiles. Discussions with local flight instructors lend credence to the pilot responses. They cite the difficulty student and experienced pilots alike have in determining the proper descent attitude, and maintaining a constant descent rate and deceleration. One need only observe several helicopters on approach to see the wide approach variations performed by active pilots. They range from relatively fast and shallow "gun run" approaches, to nearly vertical and slow approaches under the same conditions. Helicopter pilots, like their fixed-wing counterparts, take some pleasure in observing and critiquing the inadequacies of other pilot's approaches. What is of concern is that a pilot on the ground can easily spot the mistake, but they are largely unnoticed by the pilot performing the approach. This indicates that pilot training, which teaches pilots the correct approach angles, should be improved.

#### Type of Operation

The next operational comparison between engine failure accidents and incidents is the type of operation in which the helicopter was involved at the time of the engine failure. The most significant aspect of this comparison is that helicopters engaged in agricultural operations (specifically, aerial application), were involved in over 23 percent of all engine failure accidents.

Whereas agricultural and external load operations show a low rate of successful autorotations, air taxi operators show a very high rate, five-to-one. In order to determine if that rate is attributable to the mission profile (high percent of time in the cruise phase of flight), the hazard survey was checked to see if any large variations in percent of cruise phase were reported by the respondents. The average percent of time spent in cruise flight by pilots in each of the operator groups was 83 percent. For air taxi operators, the percentage was only slightly greater, at 84.1 percent. The differences in the amount of time spent in the least critical cruise phase is negligible, and does not provide a rationale for the high ratio of successful to unsuccessful autorotations experienced by air taxi operators.

In order to determine whether the type of aircraft flown at the time of the engine failure was responsible for the good success ratio a comparison of accident and incident helicopter types has been made. Table 3.26 presents the results that comparison.

Table 3.26 Accident and Incident Autorotation Ratio by Helicopter Type

Type Helicopter	Number of Accidents	Number of Incidents	Accident/Incident Ratio (excluding agricultural operations)
Enstrom F28	2	2	1:1
AS 350	1	1	1:1
Scorpion	-	1	--
Hiller H-12	7	2	3.5:1
Bell 205	-	1	--
Bell 206	14	15	1:1
Hughes 269*	6	2	3:1
Hughes 369*	4	2	2:1
Bell 47*	4	2	2:1
AS 315	1	-	--
Sikorsky S-55	1	-	--

\*Number of accidents does not include aerial application accidents, in order to normalize data for comparison.

That piston helicopters exhibit a higher rate of engine failure per 100,000 flying hours is well established. As such, helicopter manufacturers reduce weight to increase the useful load of their helicopters. One component which in the past has been the object of weight reduction programs is the main rotor. During cruise flight, when the main rotor is driven by the engine, light weight rotors pose no problems, so long as they don't fail. However, during autorotation or other maneuvers when the rotor is not driven by the engine, a new situation occurs. During those situations, the rotation of the blades is impacted by aerodynamic forces on the autorotative drive portions of the blades and by inertia. When collective pitch is applied to arrest the descent rate, and drag exceeds the thrust normally supplied by the drive region. With a low inertia blade, the inertia of the blade is rapidly overcome by the drag from the increased pitch, and rotor rpm rapidly decreases. If the loss of rotor rpm occurs at too high an altitude and rpm cannot be recovered, an accident or incident is the result. This type of accident is normally referred to in NTSB statistics as being caused by "pilot-loss of rotor rpm".

An autorotation, up until the final inches before touchdown, is primarily an energy management problem to the pilot. During the descent, he stores kinetic energy in the rotating blades. Prior to touchdown, the pilot must expend that energy in order to slow his descent rate. A higher weight rotor blade can store more energy and therefore provides the pilot a greater margin for error than that afforded by light weight rotors blades.

The data in Table 3.26 show that the type of aircraft flown is an important contributor to the high autorotation success rate that air taxi operators have, but that alone is not enough to account for the better ratio. Pilot experience and training is the most likely remaining contributor to success, and those elements will be explored in the following section.

### Pilot Experience and Training

Autorotation is a maneuver which, while fairly straightforward in theory, is somewhat more complicated in practice. A successful autorotation requires that the pilot analyze the emergency, initiate the autorotation, select a landing site, direct his aircraft towards it, decelerate and cushion his landing. At a nominal flight altitude of 500 feet AGL, the whole process from engine failure to contact with ground will take usually less than 25 seconds. The best preparation for an engine failure is therefore repeated and continuous practice of the maneuver so that certain reactions, such as immediate reduction of the collective and the establishment of an autorotative glide, are automatic. Training and experience provides some indication of the extent to which those procedures have been ingrained in the pilot.

Table 3.27 provides a comparison of the ratings held by the pilots in 80 emergency autorotation accidents which occurred in 1980.

Table 3.27 Ratings Held by Pilots in 1980 Autorotation Accidents

---

ACCIDENTS		
Pilot Rating	Turbine	Piston
	(17)	(35)
Private	--	11%
Commercial	59%	52%
Commercial/Flight Instructor	18%	17%
Airline Transport Pilot	11%	6%
ATP/Flight Instructor	6%	11%
Student	--	3%
Unknown	6%	--
	<u>100%</u>	<u>100%</u>

---

Furthermore, it appears that holding a commercial rating is not a guarantee that the holder is capable of performing a successful autorotations.

The airline transport pilot rating is the only rating for which the applicant must demonstrate proficiency in touchdown autorotation. All holders of helicopter ratings are exposed to autorotations from the beginning of their training. Unfortunately, touchdown autorotations are the exception rather than the rule, since most autorotation training culminates with a power recovery. The power recovery, while a difficult coordination maneuver, does not allow the simulation of the deceleration, cushioning, and touchdown phases of a true autorotation, where energy/rpm management is the most critical and makes the difference between a successful and failed landing.

The value of a touchdown autorotation over one terminating in a power recovery is amply demonstrated by the experience of the U.S. Army. The Army, the initial training site for most civil helicopter pilots, has long had the policy of performing touchdown autorotations from the beginning of initial helicopter training, with continuing training in all emergency procedures when the pilot is assigned to an operational flying position. This policy was changed in November of 1983. At that time, autorotations, simulated hydraulics failures, and tail rotor emergency training was limited to the initial phases of the maneuver, with actual touchdown completions prohibited. This policy was instituted because in the preceding years, practice emergency procedures resulted in more accidents than did the actual emergency the practice was to prepare for. Table 3.28 compares the autorotation history of civil helicopter pilots and U.S. Army helicopter pilots for the year 1980.

Table 3.28 Comparison of Civil & Military Pilot Autorotation Experience, 1980

	Civil Pilots	Army Pilots**
Total Autorotation Chances*	80	7
Total Accidents	52	7***
Total Training Accidents	14	10
Training/Emergency Accident Ratio	1:5.7	1:0.7
All Cause Emergency Autorotation Accident Rate	1.94/100,000 hrs	.33/100,000 hrs

\* Total chances includes all in-flight engine failures for which a successful autorotation was possible.

\*\* For comparability, Class A, B, C mishaps are termed "accidents in this report.

\*\*\* Two of seven Army emergency autorotations resulted in no additional damage to the helicopter, but are classed as accidents due to the dollar value of the damage/failure which forced the autorotation.



These data are even more startling, inasmuch as it has been previously shown that Army Pilots, for the most part have significantly less aeronautical experience than do civil pilots. One measure of that experience is awards presented to Army pilots for longevity in the aviation field. Less than 10 percent of all Army aviators are awarded the master aviator designation. The primary requirement for that award is 3,000 hours of flight time. The other award is the Senior Aviator designation. This is awarded when the pilot accumulates both 1,500 flight hours and five years of aviation service.

Army pilots have been successful at their autorotations largely because of repetition of the procedures. In the past, they have been required to perform a minimum of 2-day and 2-night autorotations per semi-annual period. In reality, most aviators performed far more than this number.

The recent change in the policy affords an excellent opportunity to compare accident rates of a large helicopter population under two significantly different training philosophies. However, to date, no statistics have been published concerning Army accident data for Fiscal Year 1984, the first year of the "no touchdown" policy. The effect of eliminating touchdown termination training will become known in time. The analysis should be directly applicable to civil helicopter training since the new policy reflects the civil philosophy on the subject.

Some lessons are already being learned. In the first year, while the overall accident rate is remaining essentially unchanged, the degree of damage to aircraft has shown a significant increase due in part to more expensive (UH-60) aircraft. It is not known at present whether this phenomenon is attributable only to an increase in emergency autorotation failures, or if it represents only a bubble in the data which would be unnoticeable if a longer history was analyzed. One fact relating to autorotations has been noted. That is, that individual pilots ability to perform precision autorotations to a particular point has been degraded in the past year. In 1983, prior to the institution of the "no touchdown" policy, instructor pilots from the U.S. Army Aviation School, Ft. Rucker, AL, evaluated several dozen active Army pilots, with differing experience levels, in their ability to perform a precision autorotation. A precision autorotation is one where the pilot lands to a particular point with a minimum of ground run, in the year following institution of the policy, those same pilots were retested. It was found that they were still able to perform a safe autorotation to the ground, but had lost some of their ability to land at a prescribed point with no ground run.

The Army enjoys a considerable advantage over the civil community with respect to pilot training. Since aviator training is recognized as a significant and valid Army mission, it is easy by comparison to adjust training/service hours as deficiencies are noted. Furthermore,

standardization of the training program facilitates training of the pilots and the recognition of individual and unit training shortcomings. Finally, a unified command structure, which emphasizes safety, insures that appropriate remedial actions are instituted when shortcomings are noted, and before a problem becomes endemic. These advantages resulted in a Class A mishap rate of 2.41/100,000 hrs and an overall accident rate of just 5.4/100,000 in fiscal year 1980, despite a less experienced (definitionally) pilot population flying equally rigorous mission profiles.

The civil community enjoys no such advantages. With the exception of flight schools, pilot training is a detractor from each operator's primary service mission. And with over 1500 helicopter operators in the United States there is neither training standardization or a unified command structure which can insure that necessary (as opposed to regulated) training is accomplished.

Yet some operators, notably some airtaxi operators, have managed to maintain a substantially higher level of autorotation proficiency than operators involved in other helicopter applications. An examination of the accident briefs for these accidents revealed an interesting trend. It clearly showed that airtaxi operators whose flights originated from several cities in Louisiana (Houma, Intracoastal City, Grand Chenier and others) demonstrated a similar low accident rate. A logical supposition is that the pilots were employees of one of the major offshore petroleum operators who are the principle operators in the region and who often require specific practice autorotations annually.

One question from the hazard survey asked pilots to state the frequency with which they performed various practice emergency procedures, other than during the annual or biennial flight reviews. The results for each of the operator groups, and for offshore operators are shown in Table 3.29.

Table 3.29 Survey Results: Annual Number of Practice Emergency Procedures (by Operator Group)\*\*

	Hovering* Auto	Standard* Auto	Lo Level* Auto	Percent of Trust	Emergency Governor***
Corporate/Executive	10.7	9.0	5.5	5.6	4.6
Commercial	12.9	12.7	10.3	8.3	7.6
Civil Government	10.6	16.8	7.4	3.5	.5
Offshore	11.5	11.8	7.6	6.7	5.0

\*Touchdown Termination

\*\*Excludes annual or biennial flight reviews

\*\*\*For those aircraft so equipped

The survey results were inconclusive with respect to apparent differences in the quantity of emergency procedures performed annually. Follow-up phone calls were made to several offshore operators in order to clarify the questionnaire data and provide insight into the training and operational environment experienced by offshore pilots. Those conversations shed a great deal of light on the high success rate of offshore pilots.

New pilot orientation for offshore pilots begins immediately upon being hired, and takes approximately two weeks. In addition to familiarizing new pilots with company procedures and flight routes, a great deal of time is spent perfecting autorotational technique. During that period, new pilots are subjects to over 100 touchdown autorotations, and an additional 25 unannounced hovering autorotations. The majority of the standard autorotations are from an altitude of 300 feet with a 180° turn and are terminated with a water landing with floats deployed. Repeated exposure to the autorotation maneuver was cited by the instructor as the primary reason for the offshore operators good success rate during in-flight engine failure.

In addition to initial training, offshore pilots undergo annual training in which the pilots ability to perform autorotations and other emergency procedures is evaluated. Pilots who do not perform the maneuvers satisfactorily are given additional training to insure that they can be safely accomplish the required maneuvers in an emergency.

As an example of the level of proficiency that these policies afford the pilots, the instructor cited the results of 31 engine failures which his company experienced over a several-year period in the early 1980's. Of the 31 failures, 27 were successfully autorotated with no damage to his aircraft or crew. Two aircraft were damaged when the floats did not inflate, and only two sustained damage as a result of the autorotation. When one contrasts this success rate to that experienced by all other operator groups, the value of repeated practice of autorotations, with power off terminations to the ground, is readily apparent.

As discussed earlier, autorotations are essentially an energy management maneuver. An important aspect of energy management is the pilots ability to accurately estimate his height above ground level, since his actions are dictated by this factor. Repetition of the maneuver facilitates pilot recognition of visual cues which help him to determine his altitude, and reinforces his ability to complete the maneuver. However, when an actual failure occurs at a location other than his training site, he may experience difficulty in determining his altitude, since many of his visual cues are specific to his training site. This inability to accurately estimate his altitude is a great contributor to autorotation accidents.

The ability to estimate altitude is facilitated when the pilot has cues other than visual, and altitude information supplied by barometric altimeters. Perhaps the best cue is provided by radar altimeter. These devices supply the pilot with absolute altitude above the surface, rather than sea level, and as such provide far more accurate altitude information than could be acquired through visual and barometric altimeter clues. At night, or during IMC operations, radar altimetry is the only altitude information which the pilot could use with confidence. It should be noted that offshore operators employ far more radar altimeters on a per aircraft basis than any other single operator group.

Inasmuch as inadequacies in the pilots ability to perceive his relative altitude during a high-speed autorotative descent is a major contributor to his inability to perform autorotations, this aspect of autorotation accidents is the most amenable to a technological solution. Incorporation of radar altimeters offers the best means currently available to substitute pilot altitude estimates with accurate altitude information. However, radar altimeters measure distance along the mast axis and would not give accurate distance to the ground at high bank angles. A bank angle corrected radar altimetry system may be the ultimate solution. The advantages of radar altimeters data could be further enhanced by incorporating that data in advanced displays, such as heads up displays, which would free the pilot from in-cockpit scans for the data necessary to successfully accomplish an autorotation.

#### 3.2.2.3 Summary of Root Causes of Powerplant Failure Accidents

Powerplant failures were either the direct or indirect causes of 30 percent of the helicopter accidents which occurred during 1980. Of these 79 accidents, fully 51 percent were the result of pilot action or inaction which caused the engine failure, or pilot action which resulted in the failure of the resultant autorotation. As such, the powerplant failure accident is of special interest since it is the result of several varied "root causes". These root causes are in many cases, not peculiar to powerplant failure accidents, but are evidenced by all types of helicopter accidents. A summary of root causes of powerplant related accidents, and possible solutions to those problems are presented in Table 3.30.

#### 3.2.3 Pilot-Failed to Maintain Adequate Rotor RPM

The detailed accident cause "Pilot-Failed to Maintain Adequate Rotor RPM" was cited as the proximate cause of helicopter accidents 19 times in 1980. This is over seven percent of all helicopter accidents, making it the fourth most prevalent cause of helicopter accidents. This class of helicopter accidents is generally characterized as being caused by pilot mismanagement of power or energy which allows a decrease in main rotor RPM and a subsequent loss of lift.

Table 3.30 Summary of Root Causes of Powerplant Failure Accidents

System Failure	How Failed	Why Failed (Root Causes)	Remedies
Aircraft	Insufficient power availability	Powerplant is insufficient for task in which it is employed	Develop low cost, simple power available vs power required indicators. Improve powerplant reliability
Operator	Auterotation Accident	Standard emergency procedures are inadequate for some mission types/profiles	Adjust mission profiles to minimize operations within the no fly region of the aircrafts height velocity-diagram. Develop and increase training of nonstandard autorotation techniques. Improve powerplant reliability.
Environ-ment	Auterotation accident	Terrain inhibits successful completion of forced landings	Increase flight altitudes to expand autorotation radius. Plan route of flight to take advantage of available forced landing areas.
Environ-ment	Auterotation accident	Meteorological restrictions to vision inhibit successful completion of forced landings	Develop multisensor (FLIR, LLTV, Laser, etc.) systems for flying in reduced visibility conditions. Include radar altimeter as required equipment for IFR flight to permit autorotations in limited visibility conditions
Pilot	Failed to maintain Rotor RPM (autorotation)	Low inertia rotor blades promote easier power off decay in autorotation and are not as forgiving	Develop auxiliary power technologies for application during autorotation. Examine applications of high inertia rotor. Improve aerodynamics of the rotor to provide a large autorotational drive region on the rotor blades. Heads up display with airspeed/altitude/& rotor RPM data. Improve training.

Table 3.30 Summary of Root Causes of Powerplant Failure Accidents  
(Continued)

System Failure	How Failed	Why Failed (Root Causes)	Remedies
Power-plant	Engine Failure-miscellaneous	Helicopter mission profiles promote accelerated wear of helicopter engines	Develop improved engine life cycle procedures which simulate helicopter operations. Adjust TBO's for engines based upon missions to which they are applied. Improve vibration isolation for engine accessories and fuel/air lines. Develop low cost, automated engine cycle and condition monitoring system.
Pilot	Autorotation accident	Mission profiles of some helicopter missions lay within the no-fly region of height velocity envelope	Adjust mission profiles/procedures to minimize operations within the no-fly regions of the height/velocity envelope. Develop high inertia rotor system to reduce/eliminate no fly regions of H.V. diagram. Improve powerplant reliability.
FAA	Autorotation accident	Inadequate training (touchdown autorotations not required)	Mandate touchdown auto training for initial and recurrency helicopter training.
Pilot	Autorotation accident	Pilot could not estimate height above touchdown	Mandate touchdown autorotation training initial and recurrency helicopter training. Provide radar altimeter data to preclude inaccurate estimation of height above touchdown.

The most notable similarity between accidents of this type is the disproportionate percentage of piston helicopters which comprise the 19 accidents. The NTSB states that 16 of the 19 accidents involved piston helicopters, whereas they (piston helicopters) accounted for only about 45 percent of all helicopter hours flown in 1980. (Note - A review of the accident briefs by SCT produced somewhat different data; i.e., 14 of 19 accident helicopters were piston powered. A possible explanation is that the NTSB aggregation may have included a Hiller H1100 as a piston accident, rather than turbine. No explanation is offered for the remaining difference). The explanation for this disparity is shown in Table 3.31. As can be seen, nearly half of the accidents of this class occurred during pilot training. It has already been shown that initial pilot training is conducted primarily in piston powered helicopters. When instructional accidents are removed from the list, the percentage of turbine and piston "RPM" accidents are approximately normal to their representation in the fleet, at 50 percent each.

Table 3.31 Type of Flying for "Pilot-Failed to Maintain Rotor RPM" Accidents, 1980

Type Flying	Instances	Percent
Instructional	9	47%
Agrigultural	2	11%
Air Taxi	2	11%
Personal	2	11%
Industrial	1	5%
Business	1	5%
Executive	1	5%
Other	1	5%
Total	19	100%

### 3.2.3.1 Pilot/Instructor Training

Since pilot training accounts for such an inordinate share of "RPM" accidents, it deserves special attention in the discussion. Of the nine training accidents (all in piston helicopters) four occurred during practice hovering and five occurred during practice autorotation. In Section 3.2.2, in the discussion of engine failures, inadequate management of rotor RPM (energy management) was highlighted as a cause of engine failure accidents. Furthermore, low inertia rotor blades and the pilots inability to accurately judge relative altitude (the most important element in managing rotor rpm) were cited as root causes for engine failure accidents. That these factors are manifested in training supports

those conclusions. However several additional root causes of engine failure accidents can be raised as a result of the analysis. These causes relate to the training and qualifications of the instructor pilots themselves. For example, of eight instructors to whom the accident were attributed, five instructors had less than 76 hours in the accident aircraft type during the previous 90 days. Four of those instructors had received a type rating in the accident aircraft; and flown all of their time in type, in the previous ninety days. Furthermore, these instructors had less than half of the total flight experience than that of the operator survey sample. The significance of these data is that these instructors are relative newcomers to the particular aircraft, and are substantially less experienced than other professional pilots. The root cause of these accidents might therefore be:

- o Instructor pilot did not correct a hazardous flight condition because of unfamiliarity with the aircraft.
- o Instructor pilot failed to correct a hazardous flight condition because of overconfidence in his student.

and finally, a corollary cause:

- o Instructor pilot failed to initiate early corrective actions because of overconfidence in his own abilities.

It is difficult, if not impossible, to assess the impact of these three possible root causes on all helicopter accidents, although they are certainly arguable causes for the nine accidents in question. Likewise, it is improbable that the nine accidents pilots represent the sum total of inexperienced helicopter instructor pilots. The fact is, it is legally possible to obtain a helicopter instructor rating with only 50 hours of total helicopter time, if the applicant already holds a fixed-wing instructor rating. As an example, one pilot interviewed recently obtained his commercial helicopter rating with the minimum of 50 hours flight experience and has already been offered work as an instructor by the same flying school from which he received his training.

This scenario is repeated on a daily basis, and is, in fact, the way a large number of helicopter pilots accumulate sufficient flight hours to move on to more stable and better paying helicopter flying positions. The situation is aggravated somewhat by the shortage of FAA helicopter examiners. During discussions with members of the California Professional Helicopter Pilots Association instances were cited in which fixed-wing FAA examiners certified private and commercial helicopter pilots. In some cases, when a demonstration of autorotation (with a power recovery) was required, the examiner stayed on the ground and evaluated the maneuver from that location.

The discussion above is based on both anecdotal data supplied by the survey group and the authors' own experience and observations. It is not intended to be a portrait of the helicopter flight instruction system as a whole, but only to highlight some of its inadequacies. For the most part,



civil helicopter training is conducted by fully qualified and experienced instructors. However, given the volume of helicopter pilot training conducted, and the number of separate operators providing the service, it must be expected that deficiencies in pilot/instructor training do exist. Therefore, a root cause of some helicopter accidents is likely to be

- o Inadequate pilot and instructor pilot training and certification.

The extent to which inadequate instructor training and certification affects the accident rate is not known, nor are such statistics collected or maintained. However, this cause would underlie a variety of pilot error accidents attributed to pilots trained by unqualified pilots.

#### Turbine vs Piston "RPM" Accidents

Piston helicopters, unlike those powered by turbines, have their engine power manually controlled by the throttle, with no correlation of throttle, collective and anti-torque input. As such, piston helicopters require substantially greater pilot workload and coordination to keep engine and rotor RPM in the operating range than does a turbine helicopter in which the governor automatically maintains engine (and rotor) RPM within the green arc. This characteristic, coupled with the responsiveness to power demands of piston helicopters make piston helicopter operations such as hover, takeoffs and landings significantly more demanding than is experienced with turbine powered helicopters. For pilots undergoing initial training in helicopters, mastery of throttle, collective and anti-torque pedal coordination is the single most difficult training task, according to several of the surveyed pilots. Thus, the four "RPM" accidents which occurred during initial training are to a degree predictable.

#### 3.2.3.2 RPM Control

The next major category of "Pilot-Failed to Maintain Rotor RPM" accidents involved helicopters, both turbine and piston powered, which encountered strong and gusty winds or adverse winds at low altitude. A maneuver requiring high power can result in a loss of rotor RPM. Helicopters are much like airplanes in that they are most efficient when operating into the wind. When a sudden wind shift occurs, a pilot must immediately increase power and raise the collective to compensate for the loss of lift due to the wind shift. If the helicopter is near maximum gross weight, the engine may not have sufficient power to maintain the downwind hover, rotor RPM will decay, and a hard landing will occur. In at least two of the accidents of this type, high density altitude may have contributed to the loss of rotor RPM. The root cause for this type of accident is:

- o Operation of the helicopter at or near maximum power

### 3.2.3.3 Summary of "Pilot-Failed to Maintain Rotor RPM"

Inadequate pilot and instructor training, operations at or near maximum gross weight, and coordination requirements in piston helicopter all contributed to this class of accidents. Each of these root causes are also contributors to accidents of different classes. One of the causes, inadequate instructor training, has repercussions far beyond the nine accidents to which it is directly attributable. A summary of the root causes of this class of accidents is presented in Table 3.32.

### 3.2.4 Pilot-Failed to See and Avoid Objects or Obstructions

The NTSB classified 16 accidents in 1980 under this cause. The vast majority of these accidents (88 percent) occurred as a result of pilots flying into wires. There appears to be no correlation between pilot experience or type of helicopter flown. However, a significant and disproportionate number of accidents occurred during agricultural spray operations. This suggests the obvious conclusion that low level operations present a greater wire-strike risk than higher altitude operations.

The case may be made for various causes of wire-strike accidents. However, the root cause of this class of accidents may be stated very simply.

- o Pilot could not see the object.
- o Pilot could not avoid the object.

Within each of these basic causes, other factors can be attributed. In the following sections, the contributors to these two causes are discussed.

#### 3.2.4.1 Pilot Could Not See the Object (Wire)

The NTSB accident briefs for 1980 do not specify the reasons that the pilots could not see the objects in question. However, through discussions with the surveyed pilots, it is possible to surmise some of the reasons. Some of the reasons presented by the pilots are:

- o Distortion of vision by windshield.
- o Windshield glare restricted pilots vision.
- o Low level operations in marginal visibility.
- o Wires not marked.
- o Pilot preoccupation with other tasks.

Table 3.3.2 Summary Root Causes of "Pilot-Failed to Maintain Rotor RPM 4 Accidents

System Failure	How Failed	Why Failed (Root Causes)	Remedies
Pilot	Student pilot lost control of helicopter	Instructor pilot did not recognize a hazardous flight condition because of unfamiliarity with the helicopter  Instructor pilot failed to correct a hazardous flight condition because of overconfidence in his student Instructor failed to initiate early corrective actions because of overconfidence in his own abilities	Increase Flight experience requirements in type for potential instructor pilots Increase standardization (particularly throttle control) in instruction helicopters. Develop a more forgiving instruction helicopter (high inertia rotor).  as above
Pilot	Lost RPM & Directional control of	Inadequate pilot/instructor pilot training and certification	Increase helicopter flight experience requirements for pilots Include decision making training in instructor curriculum.
Tail Rotor System	Loss of Tail rotor effectiveness	Operation of the helicopter at or near maximum gross weight/power  Winds, inadvertent high power demands, pilot inattention, maneuvering downwind	Power available vs power required instrumentation combined with antitorque requirements. Improved pilot training and proficiency.  Develop high performance tail rotor which minimize power consumption Provide training on wind effects, low RPM, inadvertent high power required and maneuvering in winds.

Table 3.32 Summary of Root Causes of "Pilot-Failed to Maintain Rotor RPM" Accidents  
(Continued)

System Failure	How Failed	Why Failed (Root Causes)	Remedies
NWS/FSS	Pilot lost directional control of helicopter	Density altitude information not available at most sites Wind direction/velocity information not available at remote sites	Wider dissemination of density altitude information Wider dissemination of wind direction/velocity information
Flight Controls	Pilot lost directional control of helicopter	Nonstandard throttle control between different aircraft types No correlation between throttle, collective and pedal controls	Standardize throttle advance/retard direction on collective control Incorporate governor with collective, throttle, and anti-torque correlation for piston helicopters

Table 3.33 Type of Helicopters Involved in Wire Strike (Sole Cause) Accidents (1980)

Type	No. of Accidents
Hiller H-12	2
Bell 47	4
Bell 206	6
Hughes 369	<u>2</u>
	14

Table 3.33 indicates that the Bell 206 was involved in the largest number of wire strike accidents.

During conversations with pilots on the subject of cockpit visibility, several pilots cited distortion from Bell 206 wind shields as a visibility restriction. The pilot and co-pilot windshield, particularly around the windshield frame, causes the greatest amount of distortion. The cause of the distortion is the curvature of the plexiglass which causes refraction of light passing through it, and in some cases, apparent magnification of objects viewed through it.

Elimination of distortion by the windshield was a primary design goal of the U.S. Army when they announced the upgrade of several thousand OH58A (Bell 206 equivalent) helicopters and AH-1 helicopters with flat, glass windshields. Because of the large amount of low level N.O.E. (Nap-of-the-Earth) flying performed in these helicopters, and the high incident of wire-strikes they encountered, particular emphasis was placed on improving cockpit visibility. The incorporation of flat planed windshields, and replacement of plexiglass with high impact glass was evaluated.

As mentioned, plexiglass, while lighter and more economical than glass, has several significant drawbacks. In addition to being more prone to distortion than glass, it is also far more easily scratched. A scratched windshield is both a distraction to the pilot, and a hazard since it prevents full visibility and contributes to the effects of glare. Moreover, in order to prevent scratching of the surface, pilots wash the windshield less often than is necessary, and thereby aggravates

the visibility problem. Similarly, on aircraft such as the Bell which are equipped with windshield wipers, pilots will refrain from using them in the rain to prevent scratching of the windshields.

Another reason that pilots are unable to see wires is that the wires themselves are not marked. Wires are obviously small targets, and are often difficult to distinguish against the varying backgrounds in which helicopters operate. Pilots are taught the methods to predict the presence of wires even when they are unseen or difficult to see, and for the most part pilots are successful in avoiding them. However, the techniques such as looking for cuts in vegetation, utility poles, etc., and inferring the presence of wires can never eliminate all wire-strike accidents since not all wires can be detected and avoided with that technique. Furthermore, in several cases, marked wires were the subject of the wire-strike.

In five cases, reduced visibility was cited as a contributing factor to the wire-strike accident. All five occurred during VFR, with two at night, and three with haze, fog and rain as contributors. In each of these instances, the case may be made that the pilot exercised poor judgement in flying at low level without adjusting his airspeed to accommodate the reduced visibility conditions. Pilot error was not cited as a factor in any of the five accidents, however. It is clear that as long as wires are present in the operating environment, and pilot's only means of avoiding them is to either to detect all wires or exercise sufficient judgement to avoid those he doesn't see, wire-strikes will continue to occur. It remains for manufacturers, therefore, to develop automatic wire detection equipment and/or provide equipment to minimize the damage resulting from wire-strike, that is wire cutting equipment.

Again, the U.S. Army has recognized this need and is currently retrofitting all UH-1H, OH58, and OH6 helicopters with wire-strike protection equipment. The long term effect of this program will only be known when all the fleet is so equipped, although early indications are that the equipment minimizes the damage to the aircraft and is increasing the survivability of wire-strike accidents.

It was once said that the best way to avoid getting eaten by sharks is to stay out of the water. Likewise, if pilots are to avoid wire-strikes they should consider flying at higher altitude avoiding the possibility of wire-strikes.

#### 3.2.4.2 Summary of Root Causes of "Pilot-Failed to See and Avoid Objects or Obstructions" Accidents

Table 3.34 summarizes several of the root causes of wire-strike accidents, and other accidents in which the pilot failed to see and avoid an object. Some of the causes which relate to a pilot's ability to see or react quickly are discussed in greater detail in Section 3.4.

### 3.2.5 Other Accident Causes

In Table 3.11, the ten most prevalent detailed accident causes, as established by the NTSB, were presented. To this point, four of those detailed causes have been investigated, as well as an in depth discussion of engine failure accidents. These discussions have focused on 144, or 55 percent, of all helicopter accidents reported to the NTSB during 1980. It was previously stated, that an important indicator of a root cause, in fact, a requirement for that categorization, is that when the root cause conditions exist, they will continue to manifest themselves in an accident. In the previous sections, a list of root causes of helicopter accidents has been developed and presented. These same root causes are manifested in accidents in the remaining six "most prevalent detailed accident cause" categories. However, two types of accidents, both of which are repeated, and of serious consequences, have been omitted from the discussion. These accidents are:

- o Tail Rotor Failure Accidents
- o Main Rotor Failure Accidents

During 1980, these two accident types account for 11 percent of all accidents. While they are categorized by the NTSB as "Miscellaneous Acts, Conditions-Material Failure", they are treated in this investigation as separate accident types.

#### Main Rotor Failure

In 1980, a total of 17 "main rotor failure" accidents were reported. Unlike most other accidents types, main rotor failure accidents increased both in number and in rate over the previous three reporting years. The increase was quite large, nearly 200 percent, although the numbers remain fairly small and the increase may not be statistically significant. This conclusion is supported by the fact that the increase was reported for

Table 3.34 Root Cause of Pilot-Failed to See and Avoid Objects or Obstructions Accidents

System Failure	How Failed	Why Failed (Root Causes)	Remedies
Pilot	Pilot could not see object	Curved plexiglass canopies/windshields distort pilots view	Develop non-distorting pilot windshields/canopies
		Windshield glare restricts pilots vision	Develop non-glare pilot windshield
		Low level operation in marginal visibility	Avoid low level/low visibility flight airspeed commensurate w/visibility Increase altitude commensurate w/visibility
		Wires not marked	Develop wire and wire like object detection system (laser, multisensor, etc.)
		Pilot preoccupation with other tasks	Cockpit/flight control design to reduce pilot workload
Pilot		Pilot did not use ground flagmen during agricultural operations	Safety evaluation of mission requirements Operator must institute and monitor procedures, and provide resources, which will assist pilots in wire detection
Pilot		Pilot did not perform reconnaissance of survey of T/O or landing	Make decision making training part of basic and recurrent training.
Pilot	Pilot could not avoid object	Pilot's performance was impaired by fatigue	Adjustment of crew rest policies in accordance with the workload and hazards of various missions. Operator supervision of crew rest policies.
		Late recognition of the hazard	Develop and retrofit helicopters with light weight wire-strike protection devices



both piston and turbine helicopters, and is not specific to a particular class or model of helicopter.

When discussing accidents classed as main rotor failure accidents (or tail rotor accidents) it is important to realize that the NTSB does not imply failure of the rotor blades alone. Rather, the failure of any element of the rotor drive system from the engine to and including the rotor assembly is considered to be a failure of that particular assembly. In actual fact, none of the 17 accidents attributed to this type failure actually involved the main rotor blades itself. Likewise, only four of 13 tail rotor failures were actually failures of the tail rotor blades.

As with all accidents discussed thus far, piston helicopters experience an inordinate number of main rotor failures, relative to their exposure in the fleet. 11 of the failures reported in 1980 were in piston helicopters, while only six occurred in turbine helicopters. And again, aircraft involved in aerial application (pistons) were most frequently involved in this type of accident. Surprisingly, a trend noted in the discussion of engine failure accidents was evidenced also in this category. That trend is that sling load operations have both a high main rotor system failure rate, and a low failure recovery rate. Nearly 18 percent of all such accidents occurred during this helicopter mission. Two of the four slingload accidents occurred in turbine powered helicopters.

The various modes in which the main rotor systems failed are shown in Table 3.35.

Table 3.35 Main Rotor System Failure Modes, 1980

Type Helicopter	Failure Mode	No. of Occurrences
Piston	Sprague Clutch Failure	4
	Transmission Bearing	3
	Transmission Drive Shaft	2
	Sun Gear	1
	Rotor Hub	<u>1</u>
	Subtotal	11
Turbine	Transmission Drive Shaft	2
	Sprague Clutch Turbine	2
	Mast Failure	1
	Loose Bolt (Cyclic Control Rod)	<u>1</u>
	Subtotal	6
	Total	17

As can be seen, three of the failure modes are "repeat offenders," and are therefore the focus of the remainder of the discussion.

Sprague clutch failure is the most common form of main rotor system failure. It manifests itself in two ways: engaged failure or disengaged failure. In the cases cited, the failure was in the disengaged mode. This failure results in the main rotor freewheeling from the transmission, that is, engine power is no longer transmitted to the rotor system. In the engaged failure mode, the main rotor cannot be disengaged from the rotor drive, and any decay of engine RPM will drag the main rotor also. This is the most serious form of clutch failure, since it precludes autorotation. Although it is the most serious form of failure, it rarely results in an accident, since a normal, (if hurried) landing can be made once it is detected. It will usually not result in an accident unless it is coupled with a complete or partial powerplant failure.

The cause of clutch failures is normal wear and tear of operation. The wear and tear is hastened in piston helicopters since the clutch also acts as a shock absorber. Recall that with ungoverned piston engines, power demand is far more rapidly met than in turbines, which have an inherent spool up lag. In addition, since piston engines normally do not have collective and throttle correlation, they require far more direct throttle control by pilots. In certain phases of flight, such as hovering, takeoff and landing, the piston pilot must constantly regulate engine RPM with the throttle control. In helicopters, the clutch will only disengage (under normal conditions) when engine driving RPM is less than what it is driving.

A root cause, applicable primarily to piston helicopters, is:

- o Clutch failures are the result of frequent engagement/disengagement cycles.

One solution to this cause is using a governor control. A second solution to clutch failures is better monitoring and maintenance procedures to detect the problem before the clutch fails.

The same root cause and solution is applicable to transmission drive shaft, or short shaft, failure accidents. The short shaft, like the clutch, transmits the torque supplied by the engine. Short shaft failure is normally manifested by a shearing of the shaft at the coupling, due to lack of lubrication. It results in a loss of engine drive to the main rotor system, and necessitates an immediate autorotation.

Failure of internal bearings of the transmission is the next most common cause of main rotor system failures. In 1980 all of the failures were the result of a crack, and subsequent loss of transmission lubricant. This type of failure is potentially the most serious form (short of loss of the rotor head or blades themselves) of failure since it may result in a seizure of the transmission and stop the rotation of the blade. Some helicopters have a 30-minute performance capability after loss of lubrication. However, transmission overhaul is required when this occurs.

Bearing failure is the product of vibration, heat and its fatigue effects on the bearings and bushings. Elimination of this failure mode is dependent upon the development of improved methods of vibration isolation and reducing transmission lubricant heat. Planar gears currently in development will produce these results, with the added benefit of providing more torque to the rotor system with reduced weight and part counts.

Tail Rotor Failure

During 1980, 13 tail rotor accidents were recorded by the NTSB, of which ten involved turbines. This represents both a reduction in number of accidents and accident rate for both types of helicopters from the preceding three years. Table 3.36 lists the causes/failure modes of tail rotor failure.

Table 3.36 Tail Rotor Failure Modes/Causes. 1980

Type Helicopter	Mode/Cause	No. of Occurrences
Piston	Tail Rotor Gearbox (90°) failed	2
	Foreign Object Damage (FOD)	2
	Inadequate Maintenance	2
	Drive Shaft	2
	Lost Grease Fitting	1
	Tail Rotor Yoke	<u>1</u>
	Subtotal	10
Turbine	Inadequate Maintenance	1
	FOD	1
	T/R Drive Shaft Coupling	<u>1</u>
	Subtotal	3
Total		13

Two causes accounted for nearly half (46 percent) of tail rotor failures. Foreign object damage (FOD) was responsible for three failures, as was inadequate maintenance. The root causes of these two failure modes

have been described previously (FOD - Failure to See - and Avoid Objects, and (Maintenance - Inadequate Preflight Inspection), and as such, shall not be belabored here. A possible solution to both causes may be available for future generations of helicopters, in the form of NOTAR (no tail rotor technology). This technology employs a total rotor mounted internal to the test boom with a control nozzle at the aft end to provide anti-torque thrust. This technology eliminates the need for extended drive trains and the tail rotor and may result in reduced maintenance costs. Additionally, since the tail rotor drive train is the source of much of the damaging fuselage and cockpit vibration in existing helicopters, this hazard of helicopter flight can also be eliminated.

NOTAR technology is not applicable to piston helicopters. Thus, reducing tail rotor accidents must take a multiple direction approach. Tail rotor FOD can be prevented by providing tail rotor fairings which preclude tail rotor strikes. Similar fairings are currently incorporated in the design of the SA 365 Dauphine and the Bell 400. Incorporation of the fairings would have the added benefit of preventing rotor accidents to persons on the ground, or at least, minimizing their consequences. In 1980, for example, four such fatal accidents were recorded.

The remaining tail rotor failure modes are similar in their causes to Main Rotor failures. For example 23 percent of the failures were the result of failure of the driveshaft. The cause of this mode is similar to the cause of short shaft failure. That is, the drive shaft must transmit all of the torque of the engine and is therefore susceptible to the shear forces that result. Similarly, tail rotor gearbox failures are quite similar in their causes to main rotor transmission failures. Loss of oil is the primary cause of the failures.

Vibration and the harmonic effect of those vibrations along the tail rotor drive shaft and tail boom, are also largely responsible for failures of individual components and fittings of the tail rotor, such as those remaining in Table 3.36. These seemingly random failure modes cannot be prevented by any single component fix. Nor is it likely that a single, or several fixes will force pilots and maintenance personnel to perform the maintenance and inspection functions for the tail rotor assembly flawlessly. The best solution to the root cause accidents induced by tail rotor vibration lies in better monitoring, inspection and maintenance. Vibration levels could be monitored along the drive train so that impending failures may be predicted, and adequate warning relayed to the pilot so that he can take immediate action as necessary to land the helicopter.

### 3.3 PILOT PERCEPTIONS OF ROOT CAUSES OF HELICOPTER ACCIDENTS

In the previous sections of Chapter 3, accident data for the year 1980 was analyzed and compared with the operational profile data supplied by

the survey respondents in order to determine the root causes of helicopter accidents. In this section, the surveyed pilots own perception of root causes of helicopter accidents are presented, along with their assessment of possible solutions to those root causes. In addition, anecdotal operator comments relating to the root causes and solutions to helicopter accidents are presented in order to better illustrate the pilots' point of view, since they offer certain valuable insight not always available from a perusal of raw accident data.

### 3.3.1 Comparison of Pilots' Perspectives to NTSB Data

The survey group was asked to assign a frequency of accidents types to each of four categories of accidents:

- o Equipment Malfunction
- o Weather
- o Pilot
- o Training Accidents

Within each of the broad categories, they were further asked to indicate the percentage of those accidents which they believed were the result of specific failures or conditions. The aggregated responses to that question are detailed in Table 3.37. The exact percentage assignment to each of the four broad categories of accidents is of less importance than what it says of the pilot's accident perspective. The pilots themselves admitted to being the greatest cause of helicopter accidents, although not to the same extent that the NTSB has attributed them. Whereas pilots stated that other pilots were responsible for nearly 38 percent of all accidents, the NTSB has determined that they were either the cause of, or contributed to 60 percent of the helicopter accidents in 1980. It could be reasonably assumed that the pilots would transfer responsibility/cause of an accident from themselves to their aircraft or aircraft system, resulting in an increased causal assignment for equipment malfunction which corresponds with their reduced assignment of pilot error as a cause. Surprisingly, the survey pilots did just the reverse. While the NTSB reported that equipment malfunction was the cause of nearly 45 percent of all accidents, the pilots perceived that equipment malfunction was responsible for only 19 percent of all accidents. (NTSB all-cause statistics include some double bookkeeping, inasmuch as a single accident may have both pilot and equipment rated causes. Thus NTSB all-cause totals do not total 100 percent). This anomaly provides some insight into the causes of several helicopter accidents which are characterized as "Pilot-Inadequate Preflight Inspection and/or Planning". As powerplant, electrical and drive systems are improved with succeeding generations of helicopters, the pilots' healthy mistrust of things mechanical seems also to be on the decline. These findings seem to validate "overconfidence in his aircraft" as a root cause of some helicopter accidents. Furthermore, to the extent that overconfidence in his equipment decreases a pilot's motivation to practice emergency procedures in his aircraft, he will be less prepared to handle an emergency should one occur.

Table 3.37 Pilot Ranked Accident Categories

<b>Pilot</b>		
	Loss of Aircraft Control	10.7%
	Failure to See and Avoid Aircraft	4.0%
	Failure to See and Avoid Obstacles	8.2%
	Fuel Starvation	6.3%
	Loss of Tail Rotor Thrust	2.1%
	Pilot Fatigue	6.2%
<b>Total Pilot</b>		<b>37.5%</b>
<b>Weather</b>		
	Inadvertant IMC Penetration	15.5%
	Icing	1.7%
	Limited Visibility	10.3%
	Other	<1%
<b>Total Weather</b>		<b>27.5+%</b>
<b>Equipment Malfunctions</b>		
	Powerplant	14.1%
	Tail Rotor	3.4%
	Main Rotor	1.3%
	Flight Controls	<1%
	Electrical Failure	<1%
	Loss of Hydraulic Pressures	<1%
	Airframe Failures	<1%
<b>Total Equipment</b>		<b>18.8+%</b>
<b>Training Accidents</b>		
	Practice Emergency Procedures	7.5%
	Mission Training	2.0%
	Other	1.3%
<b>Total Training</b>		<b>10.8%</b>

Whereas pilots underrated the impact of pilot error and equipment malfunction as causes of helicopter accidents, they vastly overrated the impact of weather as an overall accident cause. Pilots attributed nearly 28 percent of all accidents to weather, (principally IMC conditions) while NTSB records show that only 12.5 percent of all accidents in 1980 were either caused by weather or contributed to by weather. Moreover, the majority of weather related accidents cited by the NTSB had nothing to do with icing or restrictions to visibility as the pilots thought, but rather to shifting gusting winds and density altitude. The pilots significantly overstated the hazard of inadvertant IMC penetration, since they perceived that nearly 16 percent of all accidents were in that category. In fact, in 1980 less than two percent of the accidents were

related to this accident cause, a reduction from the previous three years. The pilot's perception of weather as a significant accident cause reflects their concern over flying in instrument conditions in the noninstrument helicopters. It can be argued that pilots healthy respect for the weather hazard plays an important role in minimizing the contribution of weather to the overall accident rate.

### 3.3.2 Fatigue

In previous sections, pilot error, in its various forms, has been cited as a cause/factor in helicopter accidents. However, no specific discussion of one of the most important contributors to pilot error, fatigue, has been presented. In the following section specific elements of pilot fatigue are discussed, with emphasis upon those appropos to pilots in particular.

Fatigue is primarily the product of stress, and as such can be induced by a variety of stressful conditions. These conditions range from mild illness, to familial arguments; excessive consumption of alcohol and tobacco products, or problems on the job. Every person undergoes these or other stressful conditions, and has their mental and physical abilities impaired by the resulting fatigue. Pilots, because of the nature of their work, which requires both attention to detail and physical and mental acuity, need to be aware of the cause of fatigue, its affects on his abilities, and means of reducing its effects.

Pilots are well aware of the effects of fatigue, and perceived that over five percent of all accidents were the result of that condition. Furthermore, they are among the most aware of what actions need to be taken to reduce pilot related fatigue factors. Research requirements recommended by the survey pilots themselves focus on several means of reducing pilot fatigue:

- o Lower noise/vibration levels
- o Fully automated flight (block to block)
- o Cockpit redesign for crew comfort
- o Improved climate control in the cockpit
- o Heads up IFR displays
- o Improved radio frequency switching

All of these research recommendations will serve to reduce pilot workload and improve the work environment of the pilot's, and would reduce the incidence of pilot fatigue as an accident cause. Unfortunately, pilots have little control over their employer's equipment purchase practices, or his crew rest duty cycle, and as such, the above research recommendations will only result in improvements in future helicopters.

An example of the lack of influence that pilots can exercise over their employers was related to the author during interviews with a

particular operator group. In 1983, a large municipality in the Southeast United States, made a large monetary commitment to upgrade the equipment of their airborne law enforcement officers. Prior to that time, the city operated a fleet of four Bell Model 47 helicopters and two fixed-wing aircraft, used primarily for surveillance and drug enforcement. The city intended to replace two of the Bell 47's with Bell 206 Long Rangers, and asked the pilots of the aviation section to recommend avionics and accessories which would assist them in performing their mission. To a man, the six pilots recommended a minimum avionics package consisting of basic VFR radios, a VOR and Loran-C. This was consistent with their surveillance requirements, and the very low number of IMC days during a typical year. Additionally, the pilots requested that environmental control equipment, (air conditioning) be installed in the helicopters. Their request was refused, since the municipal government did not want to justify the cost of the air-conditioners to the local taxpayers. They instead ordered full, dual King Silver Crown Avionics, with Loran-C and weather radar, at an expense nearly twice what was necessary had they purchased what the pilots had requested.

Another factor over which pilots have little control is company crew rest policy. The FAA has long recognized the need for well rested aircrews and has mandated a minimum crew rest/duty cycle policy for all part 135 and part 122 operators. The surveyed pilots were asked whether or not their company had an established crew rest policy. Eighty percent of the pilots who responded to the question indicated that they did have a crew rest policy. They were further asked to indicate the extent to which they abided by the policy. Their aggregated responses are presented below:

Crew Rest Policy:

Never exceeded	-	33%
Seldom exceeded	-	44.8%
Sometimes exceeded	-	17.7%
Often exceeded	-	1%
Always exceeded when mission requires	-	3.1%

The data indicate that while most operators adhere to the policy fairly strictly, over 21 percent of the operators violate the policy with regularity. During the onsite interviews with the pilots, many indicated that the crew rest policy was only minimally adhered to, and that only pilots who were not in need of work would refuse a mission solely because it would cause him to violate crew rest guidelines. To do so would have a negative effect on that pilot's future employability with the company.

It is true that most operators that have the requirement, do have crew rest policies, and that for the most part the policies are adhered to. However, it was mentioned that the FAA's Part 135 crew rest guidelines represent minimum requirements. They do not take into account the varying workloads and resulting fatigue which result from different helicopter missions such as single pilot IFR, aerial application, pipeline patrol, and others. Nor does the FAA's crew rest policy



accommodate the cumulative effect of fatigue which results from a series of long duty days. The minimum requirement is a maximum of 14 working hours (not including commute time) of which a maximum of eight hours may be at the controls of the helicopter. Of 41 respondents, only two pilots indicated that their company's crew rest policy was stricter than the minimum requirement specified by the FAR's. The remaining 39 pilots stated that their policy was in accordance with the FAR, and that weekly, monthly and quarterly crew rest limits are determined by multiplying the number of days in question by the FAA's daily flight hour and work hour limits. This would allow a maximum of 1260 work hours in a given calendar quarter, of which 720 hours (30 days) could be spent in the cockpit.

Fortunately, common sense and helicopter maintenance requirements prevail to prevent such abuse of crew rest limits. The relevant point is however, that whether or not the limits can be practicably reached over an extended period, they are allowed, and over a short period of a week, are certainly attained. In this case, the established crew rest limits may actually contribute to both acute and chronic fatigue.

### 3.3.3 Safety R&D Requirements

This section presents the results of the sample survey of the civil helicopter operators. The main focus of the discussion is, "Safety R&D Requirements". The information was collected to represent the current and future needs of helicopter operators as determined in Phase I.

In addition to the survey data, this section will include results from a poll that was conducted on May 9, 1983, by the FAA Rotorcraft Certification Directorate.

#### Operator Survey Results: Research Requirements

The research needs perceived by the operators were collected in six basic categories. These were:

- o Vehicle Design
- o Human Factors
- o Safety
- o Avionics and Flight Controls
- o Propulsion and Drive Train
- o Auxiliary Equipment

The operators were asked to define the current research, development and engineering projects as well as future needs in each of the six categories. Their responses were based on operational facets of their employing agency, not upon any a priori knowledge of ongoing FAA or NASA research. In specifying future needs, the operators were instructed to think of helicopter operating hazards and possible technological solutions

assuming they were not constrained by cost, staffing, availability of existing technology or any such practical considerations. Aircraft design considerations were developed for both near and far term future requirements. Finally, the operators were asked their opinion as to who should provide the needed R&D -- the manufacturers or the Federal Aviation Administration.

Table 3.38 presents a summary of the operator defined R&D requirements for current helicopters. A total of 32 research areas were identified. The two categories of basic research which contained the largest numbers of operator defined needs were Human Factors and Safety. The smallest basic research area was Auxiliary Equipment. The research needs identified ranged from "Murphy" proof cockpits to full Category A OEI operational capability from restricted areas and heliports. Some of the research needs represented easy to satisfy problems with off-the-shelf technology. These include improved baggage space and access, improved headsets, better water-tight doors, digital readout gauges, a drive train monitoring system and more strobe lights for improved recognition. Several of the other operator defined current research needs were representative of longer term, more difficult and more expensive programs. A sample of these include:

- o Higher Gross Weight with Improved Fuel Efficiency
- o Reduced Interior Noise Levels
- o Improved OEI Performance
- o A Helicopter-Unique Avionics Design
- o An Engine/Drive Train Failure Prediction and Monitoring System
- o Anti-icing Systems to Include Both the Main and the Tail Rotorblades

In contrast to these near term research needs, Table 3.39 lists the future R&D requirements specified by the sample operator group. Once again, these requirements are sub-divided by the same six basic categories. The breakdown by category was:

- o Safety
- o Vehicle Design
- o Human Factors
- o Avionics and Flight Control
- o Propulsion and Drive Train
- o Auxiliary Equipment

Table 3.38 Summary Operator Defined Research Requirements  
for Current Aircraft

**A. VEHICLE DESIGN**

- 1) Greater enroute speed and range to be more flexible
- 2) Higher gross weight and increased fuel efficiency
- 3)\* Twin engine aircraft - better single engine performance
- 4) Improved visibility for see and avoid
- 5) Increased baggage space and improved access

**B. HUMAN FACTORS**

- 1) Improved ECU (cooling & heating)
- 2) Reduced interior noise levels
- 3)\* More Comfortable and crashworthy seats
- 4) Improved headsets
- 5) Fully coupled auto pilot to lessen fatigue on long IFR flights
- 6) "Murphy" proof cockpits - simplify and standardize switches, valves, etc.
- 7) Better water tight doors
- 8) Improved door handles and fewer head level projections in the passenger compartment

**C. SAFETY**

- 1)\* Provide adequate OEI performance for twins
- 2) Full Category A (OEI) operational capability from restricted area/heliport
- 3)\* Automated, in-flight failsafe systems for engine/transmission monitoring and diagnostics
- 4) Better method of passing on DMR's to other operators of the same equipment
- 5) Improved tail rotor and main rotor safety and reliability
- 6) Improve daytime visibility or provide recognition lighting

**D. AVIONICS AND FLIGHT CONTROLS**

- 1) Standardize control heads and switches
- 2) Design avionics from the start for helicopters (i.e., precision approach using airborne radar, etc.)
- 3) Remote non-precision approach capable Loran-C
- 4) Digital readout gauges
- 5) Improved stability augmentation systems

**E. PROPULSION AND DRIVE TRAIN**

- 1)\* Develop drive train monitoring system
- 2)\* Improved reliability
- 3)\* Diagnostic and forecasting system for detecting impending failures
- 4)\* More reliable (hangar life) blades
- 5) Reduce gear box and drive train noise

**F. AUXILIARY EQUIPMENT**

- 1) Anti-icing for main and tail rotor blades
- 2) ECU fully operational even at ground idle
- 3)\* Lighter emergency floatation gear
- 4) Improved anti-collision lighting

\* Indicates compatibility with FAA Rotorcraft Certification Directorate findings.

Table 3.39 Summary of Operator Defined Research Requirements  
for Future Aircraft

---

A. VEHICLE DESIGN

- 1) Safe vertical landing and takeoff, safe low speed operation
- 2) Lower noise/vibration levels
- 3) Three hundred (300) knot cruise speed
- 4) Improved fuel status/burn indications
- 5) Realtime performance envelope information
- 6)\* Crashworthy fuel cells mandatory
- 7)\* Cabin designed to prevent intrusion of other components in the event of a crash (i.e., transmissions downward into passenger compartment)
- 8) Better passenger visibility

B. HUMAN FACTORS

- 1) Fully automated flight from block to block (place the pilot in a monitor only role)
- 2) Redesign seat/controls relationship
- 3) Redesign cockpit from a crew comfort viewpoint
- 4) Reduce fatigue by minimizing vibration and stress
- 5) Better adaptability for taller pilots and passengers
- 6) Improved climate control (eliminate heat from direct sun)

C. SAFETY

- 1) Eliminate tail rotors
- 2) Reduce diameter and raise height above ground of main rotors
- 3)\* Emergency power available for takeoffs and landings
- 4) Reduce icing hazard and streamline certification process
- 5) Provide 3-D vision to the rear
- 6) Design an aircraft that will perform to factory specs under all realistic conditions
- 7) maximize "reasonable" redundancy to prevent crashes and improve crash survivability
- 8) Design an aircraft that flies without a pilot at the controls
- 9) Jettisonable fuel cells

---

\* Indicates compatibility with FAA Rotorcraft Certification Directorate findings

Table continued on following page --

Table 3.39 Summary of Operator Defined Research Requirements  
for Future Aircraft

(continued)

---

D. AVIONICS AND FLIGHT CONTROLS

- 1) On-board collision avoidance system allowing pilot to determine evasive maneuver decisions
- 2) A reliable and inexpensive collision avoidance system that is passive (i.e., not requiring all other aircraft be equipped to work)
- 3) Heads up IFR display
- 4) Storm warning and automated best route advisory system
- 5) Easier (reduced workload) radio frequency switching and switching of comm panels
- 6) Fully automated flight from block to block

E. PROPULSION AND DRIVE TRAIN

- 1) Capability of stopping blades with both engines at idle
- 2) Fully foldable main rotor for hangaring
- 3) Increased fuel efficiency
- 4) Simplify power transmission for maintainability and reliability
- 5) Multiple fuel and/or non-petroleum fuel capability

F. AUXILIARY EQUIPMENT

- 1) Helicopter that floats upright without emergency floatation gear
  - 2) Automated maintenance information and data recording system (i.e., record and count exceedence data on hot starts, over-torques, etc.)
-

In this case, the Safety category replaced the Human Factors category as far as the largest number of perceived future research needs was concerned. The Safety related needs identified covered a broad spectrum of technology from eliminating tail rotors to providing 3-D vision to the rear and even included designing an aircraft that flies without a pilot.

In the Vehicle Design category, long term research was requested to provide a 300 knot cruise speed, lower noise/vibration, a crash resistant cabin and real time helicopter performance envelope information. These programs, in addition to the other four listed in Table 3.39 in this category, represent an order of magnitude improvement over current helicopter designs.

In the Human Factors research area, the operators felt that the cockpit needed a significant amount of redesign from a psychophysiological viewpoint. Everything from a more comfortable seat to an examination of the basic seat position relative to controls was attacked. Improved climate control, reduced (minimized) stress and vibration and better adaptability for taller pilots and passengers was termed necessary.

Avionics and Flight Controls research was needed in the areas of Traffic Alert and Collision Avoidance Systems, Head-Up IFR displays, storm warning/routing data, reduced communication panel switching and radio switching were specifically mentioned.

The areas of Propulsion, Drive Train and Auxiliary Equipment proved to be of least importance from a future aircraft requirements viewpoint. However, this is only true if the research and engineering needs in these areas are satisfied for the current generation of aircraft. The second half of Table 3.39 should be reviewed for the specific needs in these three areas.

The operators' opinions as to who should provide the necessary current and future helicopter research resulted in the consensus that the manufacturers should take the lead in the Vehicle Design, Avionics and Flight Controls, Propulsion and Drive Train and Auxiliary Equipment areas. The FAA should provide the near and far term research, engineering and development in Human Factors and Safety.

As mentioned previously, the FAA rotorcraft Certification Directorate polled approximately seventy-five (75) organizations and individuals associated with the worldwide rotorcraft community to determine their assessment of the five most important rotorcraft safety issues that could be addressed through changes in the Airworthiness Standards (Part 27 and 29 of the Federal Aviation Regulations). This project was in response to

a proposal advanced at a meeting between the FAA and the European Airworthiness Authorities Steering Committee to standardize rotorcraft certification criteria to the greatest extent possible (Reference 17).

**"Responses to the request for the five most important safety regulatory items can be grouped into five major categories. Five additional items outside these categories are also identified. The major areas are sub-divided into more specific items with an attempt to list both major and specific items in accordance with the priority assigned by commenters."**

1. Damage tolerance/fatigue
  - (a)\*\* Damage tolerance (classic-limited)
  - (b)\* Fatigue lives
  - (c)\* Condition monitoring (generally system vs inspection)
  - (d) Corrosion prevention
  - (e) Composites
  - (f) Ground Loads (long taxi)
  
2. Crashworthiness
  - (a) Ultimate loads
  - (b)\* Passenger protection/evacuation
  - (c)\*\* Fuel systems
  - (d) Major structural energy absorption.
  - (e) Ditching (floatation devices, equipment, egress)
  
3. Performance
  - (a) Engine ratings
  - (b)\*\* One-engine-inoperative continued flight
  - (c) Generally improved performance for safety
  - (d) Different classification of transport category rotorcraft (utility/cargo vs passenger)
  - (e) Fuel jettison

4. Systems

- (a)\* Transmission and drive systems
- (b) Engine rotor containment
- (c)\* Condition monitoring systems
- (d) Low level/low speed IFR approach
- (e)\*\* Advanced displays
- (f)\*\* Advanced control systems
- (g) Lightning protection
- (h) Cockpit voice recorder and flight data recorder
- (i) Rotor brake tests

5. Human Factors

- (a)\* General cockpit-pilot interface
- (b) Manual throttle (mandatory especially for single engine)
- (c) Throttles on collective (mandatory for single pilot)
- (d) Maximum pilot force and delays after failures
- (e)\*\* Simple maintenance

6. Other items listed as high priority not clearly falling in the above groups are:

- (a) Define snow
- (b) Redefine modification, etc., to reduce use of old certification basis for "new aircraft"
- (c) Expedite completion of certification guidance
- (d) Require self-retaining bolts in control systems
- (e) Use of simulation to replace some certification flight tests

\*Indicates compatibility with operator defined research requirements for current aircraft

\*\*Indicates compatibility with operator defined research requirements for future aircraft



### 3.3.4 Anecdotal Operator Comments

The final analysis of operator defined, safety related R&D information will rely on the anecdotal opinions provided by the interviewees regarding "any comments or suggestions you may have concerning this program". The following significant comments and observations describe qualitatively what the operators view as critical research needs. These comments were selected from the results of the survey presented in Phases One and Two of this study. They are presented to corroborate the preceding analysis of specific research requirements and to document the seriousness of these concerns.

#### Senior Captain

"...The most serious hazard to flight safety is the lack of adequate OEI takeoff performance for twins".

#### Pilot

"...The largest area (for safety improvement) is human engineering i.e., cockpit comfort, equipment set up that would not allow its misinterpretation or misuse. Standardize controls and switches".

#### Pilot

"...The most serious hazard in helicopter flight are the VFR near misses and almost collisions. (Also my own relaxing of awareness and alertness sometimes). Biggest impediment to full utilization in the lack of accurate weather, local and enroute, for VFR".

#### Pilot

"...Hazards - Congestion in Metro Area, Poor Heliport Design..."  
"...Restraints to full utilization - A good quick IFR Type System that will allow point-to-point flight will be needed for full utilization of A/C".

#### General Manager

"...The key to improved safety is tougher training, examinations and flight checks".

#### Chief Pilot

It may appear that I have "copped out" on all the answers by advocating a fully automated system with a technician to monitor. However, almost all crashes, near crashes, over torques, over temps, missed approaches, traffic backups and all other "villains" of aviation activity (could be eliminated) if one could eliminate:

- (1) Human input which is influenced by many factors and emotions such as experience, training, equipment, fatigue, joy, sorrow, preoccupation, etc.
- (2) Cost effectiveness (you said in the instructions that cost was no factor)

If money was of no concern, I believe current technology could combine nearly infallible products with redundancy to create the ideal (in terms of today's ideals) aircraft.

I feel today's most serious hazard is the human factor, whether it be pride (get the job done no matter what), "get home-it is", lack of training, just plain ignorance, partial or total disregard for safety, etc. Once again, in the unrealistic event of total automation (technician monitored) you would eliminate the "subjective" influence and "bending of the rules".

Pilot

".... improved air conditioning and ventilation systems will help combat fatigue, a major safety hazard..."

Pilot

".... congestion in the Gulf area. Need for a traffic advisory system and improved communications..."

Pilot

"..hazard - icing. We need a helicopter certified for flight in known icing conditions".

Pilot

"Obstructions need to be more clearly defined -- they are a major hazard to flight safety."

Two additional questions were asked of the helicopter operators regarding improvements required to enhance and promote safety. These questions and their associated responses are important to the completeness of the Helicopter Operations Survey since they address operational procedures, ATC, heliports, pilot training and other safety issues not directly defined or related to the helicopter. Table 3.40 summarizes the operator responses and opinions to the two questions:

- 1) What specific improvements are important to enhance and promote safety in your operations? and
- 2) Has this questionnaire omitted any important items?

Table 3.40 Operator Opinions

- 
- 1) What specific improvements are important to enhance and promote safety in your operations?
- A) Payload increases in lighter helicopters that will allow IFR equipment, passengers, and IFR fuel requirements to be carried.
  - B) A coupled auto-pilot.
  - C) Better (honest) weather forecasting and accurate enroute weather for VFR missions.
  - D) Increased VFR visibility of other helicopters in terminal environment.
  - E) More and better heliports.
  - F) Low altitude IFR helicopter routes with precision approaches. As system now exists, special VFR is more practical than IFR in many instances. Development of low cost MLS may help.
  - G) Increases public awareness of helicopter capabilities.
  - H) Twin-engine helicopter with true OEI capability.
  - I) Redundancy of major systems to include two pilots.
  - J) Specific route structures through large city TCA's to reduce initial call-up with ATC and leave the frequency clearer for aircraft separation.
  - K) More studies into LORAN-C for primary navigation in IFR.
  - L) Pilot awareness of operating environment and limitations.
  - M) Pilot awareness of operating capabilities of aircraft.
  - N) Tougher training and examinations and flight checks.
  - P) Implement a fully automated system that requires a pilot only as a monitor. This will eliminate human error.

2) Has this questionnaire omitted any important items? Please tell us what they are?

- A) Working with ATC in high density terminal area.
- B) Overcrowded heliport operations.
- C) Average flight length (time) which indicates the frequency of exposure to takeoff and landings.
- D) Future expansion plans might show trends and give a better idea where support is needed.
- E) Improve quality control during manufacture.

---

A review of Table 3.40 Question (1) responses shows some commonality to the technological needs. However, unique to this table are the research needs identified for weather forecasting, more and improved heliports, low altitude IFR routes, reduced communications workload, pilot awareness of operating environment and limitations and "tougher training and examinations and flight checks".

In their response to Question (2), the operators stressed working with ATC, overcrowded heliports, a greater exposure to the hazards of takeoff and landing and the need for improved quality control at the manufacturer level.

All of the factors mentioned in Table 3.40 are extremely pertinent to the safety of flight as well as the public's perception and awareness of the helicopter's safety characteristics. For this reason, it is extremely important to insure that these other operational elements, which impact safety, are attacked in a coordinated fashion consistent with the helicopter related technology improvements.

In calendar year 1980, the trend of lowering helicopter accident rates has continued, to the point that the overall helicopter accident rate has approached that of the overall general aviation (fixed-wing) accident rate. While this trend is certainly positive, the benchmark of equality (RW rate = FW rate) only serves to highlight the amount of improvement which is needed, and in fact fostered the question which this survey was intended to answer. That is "what aspects of helicopter operations have resulted in a situation where highly experienced professional helicopter pilots suffer the same accident rates as are experienced by fixed-wing pilots with, on the average, less substantial aeronautical experience and qualification." To answer this question, an in depth operator/pilot survey was performed covering:

- o Mission Profiles
- o Duty Cycles
- o Operating Procedures
- o Hazards
- o Weather

The survey results were analyzed and compared to NTSB accident data and U.S. Army accident experience. The summary results of the survey are presented in the remainder of this chapter. In section 4.1, the key findings of the survey are presented in order of the most important (1) to the less significant (6). In Section 4.2, a brief summary of the most significant root causes of helicopter accidents are presented.

#### 4.1 SIGNIFICANT SURVEY FINDINGS

- (1) **The helicopter's mission profile affects the overall accident rate.**

Two aspects of the helicopters mission profile seem to affect the accident rate. The first element is the length of the average helicopter mission; the second element is the amount of time spent in takeoff/landing/and hovering phases of flight. According to the pilots surveyed, the average helicopter mission lasted 22 minutes, compared to 90 minutes for general aviation fixed-wing. During that period, a typical helicopter undergoes seven distinct power changes. These power changes more accurately predict wear on an engine than do engine hours alone. The more power changes demanded of an engine per flight hour, the faster the engine will deteriorate, and the sooner it will wear out or fail. The failure rate of piston helicopter engines in 1980 was 4N times greater than the rate of engine failure in single engine piston airplanes for the same period. This rate is nearly identical to the ratio of power changes per flight hour for the two types of aircraft. It is concluded therefore, that the helicopters mission profile actually promotes a higher incidence of engine failure.

The survey group indicated that in their 22 minute flight, nearly 85 percent of the time was spent in the cruise phase. It is true that the majority (58.2 percent) of the accidents occurred during that phase of flight; however, it is in fact the safest (in terms of probability of an accident) of all the phases of flight. The relative risk of an accident in each of the phases of flight is shown below:

Takeoff	9.36 X
Approach/landing	6.69 X
Hover	2.34 X
Cruise	1.0 X

These data indicate, for example, that for each hour flown in each phase, a pilot is 9.36 times as likely to be involved in an accident in the takeoff phase than in cruise.

In addition to hazards such as wires, trees and other obstacles associated with low level operations, the takeoff and landing phases are the most susceptible to accidents since it is in those phases that the aircraft is operated closest to its operating limits. These phases are therefore the most susceptible to engine malfunction, and reduced tail rotor thrust and main rotor RPM, and loss of tail rotor effectiveness.

- (2) **Engine failures often result in accidents even though autorotations allow the pilot the means to safely land the helicopter.**

In some cases, a successful autorotation is virtually impossible. Two missions showed a much higher autorotation failure rate than other phases. These are agricultural operations and sling load operations. In both cases, the aircraft are consistently operated outside or on the edges of the helicopters autorotational envelope. In the event of an engine failure, the pilot has either insufficient airspeed or altitude with which to perform a successful recovery.

Terrain also impairs the pilots ability to complete the autorotation. In 1980, 12 percent of the engine failure accidents may have been averted if pilots had had more suitable terrain on which to accomplish the landing. Proper selection of a route which provides sufficient suitable forced landing sites, or by flying at an altitude which will maximize the autorotational glide radius, the pilot may minimize hazardous terrain emergency landings.

The most important cause of failed autorotations is inadequate pilot training. Civil helicopter training programs do not require training in the termination phases of the autorotation (deceleration, cushioning, landing), and many autorotations are failed in those phases. Aviation organizations such as the large offshore operators, and Army Aviation who do practice touchdown autorotations, have a far more favorable autorotation success rate than any other operator group.

- (3) **Training and mission types are only two of many causes of the large differences between piston and turbine accident rates.**

The high piston accident rate is a function of powerplant reliability, aircraft controllability, rotor system design, and flight planning/preparation. Since corporate pilots can achieve comparable accident rates with piston and turbine helicopters, it would appear that flight planning/preparation could reduce piston accident rates overall.

Piston helicopters are characterized by a lack of throttle and collective coordination. Consequently, rotor RPM is extremely sensitive to both throttle and collective movement. Unless both controls are applied in a coordinated manner, rotor RPM is likely to decay or overspeed. This situation has an adverse effect on both directional and altitude control. It is further aggravated by piston helicopters with low inertia main rotor blades. When loss of rotor drive is encountered, the rotor RPM begins to immediately decay at low altitude, this situation is often not recoverable.

- (4) **Pilot training and proficiency have a greater impact on the high helicopter accident rate.**

Of all mission types for which accident statistics can be computed, two mission types, instruction and personal flying, were responsible for nearly 23 percent of all accidents in 1980. This is in spite of the fact that the two missions account for less than three percent of all flight hours. Pilots involved in both of these types of flying, including instructor pilots have significantly less aeronautical experience than pilots involved in other types of commercial flying.

- (5) **Instructional flying demonstrates a high rate of helicopter accidents.**

Based upon the analysis of 1980 accident data, (which was largely in concert with accident data for the period 1977 to 1979), the use of piston powered helicopters, and the control sensitivity inherent in those models is a significant factor in the high accident rate. Nearly all instructional accidents were of two types - loss of rotor RPM and improper use of flight controls.

Both causes are indicative of overcontrol of throttle and flight controls which can be attributed to insufficient training. Of the two main types of helicopters, piston helicopters are the most susceptible to overcontrol.

- (6) **Aerial application accidents are the third highest contributor to the high piston helicopter accident rate (25 accidents/100,000).**

A significant percentage of all piston helicopter hours flown are flown in support of aerial applications. Surprisingly, the piston accident rate for agricultural operations is less than the overall piston helicopter rate, at approximately 17.3 accidents per 100,000 hours. In fact in 1980, the agricultured helicopter accident rate was slightly lower than the fixed-wing agricultural operations accident rate of 17.6 accidents per 100,000 hours. This finding dispels the myth that the hazards of helicopter aerial applications alone contribute to the high overall helicopter accident rate.

#### 4.2 SUMMARY OF ROOT CAUSES OF HELICOPTER ACCIDENTS

This section summarizes and ranks the seriousness of the root causes of helicopter accidents. The material summarized was presented in detail in Section 3.2. That section analyzed the hazards of helicopter operations which were associated with four basic accident types (as defined by NTSB). These were:

- o Powerplant failure
- o Pilot failed to maintain rotor RPM
- o Pilot failed to see and avoid objects
- o Inadequate preflight preparation and/or planning

Tables 3.17, 3.30, 3.32 and 3.34 provided detailed system failures, hazards, root causes and proposed remedies for each of the accidents analyzed from the 1980 data base (Reference 2). This section aggregates that data set and provides a simple weighting system to assist the reader in assessing the degree of difficulty (and probably cost) associated with developing fixes or remedies to reduce the occurrence of each accident type.

The weighting system used was based on assumptions that:

- 1) Non-hardware procedural or mission profile related remedies are easier and cheaper than hardware or technology related remedies.
- 2) Rotor, powerplant, drive train or airframe design remedies are the most difficult and time consuming.



- 3) Certification related remedies are probably nearly as expensive and time consuming as design changes.
- 4) Technology improvements in avionics, controls, monitoring systems, etc. are somewhat middle of the road.

Using this rationale, the root causes were rated according to the type of remedies applicable. The weighting system used was as follows:

<u>Remedy Category</u>	<u>Degree of Difficulty</u>
Mission Profile Changes	1 (easiest)
Training/Procedures/Maintenance	2
Instrumentation/Displays/Controls	3
Certification Change or Airmen Proficiency Requirement Change	4
Airframe, Powerplant, or Rotor Design Changes	5 (most difficult)

Applying this weighting technique to each of the remedies developed in Section 3.2 for each of the four NTSB accident "types" produced three results. First, the spectrum of applicable remedies was weighted to provide a shopping list for each accident type. Second, within that spectrum there was always a range of remedies that could be worked on as time, funding and manpower permits. Finally, by summing the degree of difficulty of all remedies for each accident type, a ranking of the four broad types was obtained. The highest score indicated the most difficult type to reduce if all known remedies were pursued.

Table 4.1 provides a summary of the hazards root causes, remedies, degree of difficulty ratings and ranking of helicopter accidents derived from the analysis of NTSB accident data and the pilot survey. As shown in the table, powerplant failure accidents rank first as the most serious and most difficult to reduce. However, even within this category there are mission, procedures and training related issues, hazards and root causes which can alleviate the rate of powerplant failures. Prime remedies with longer term benefits would be engine condition monitoring systems and ultimately improved engine reliability. Similarly, in the second most difficult accident category, "Pilot Failed to Maintain Rotor RPM", remedies varied from better reporting of wind/weather related data to training, standardized throttle controls and rotor redesign (high inertia rotor). Examination of the third and fourth ranked categories of accidents in Table 4.1 is left to the reader.

Table 4.1 Summary of Hazards of Helicopter Operations and Root Causes of Helicopter Accidents

NTSB Category	How Failed (Hazards)	Why Failed (Root Causes)	Remedies	Degree of Difficulty	Rank
Powerplant Failure	Insufficient Power Available Engine Failure (miscellaneous) Autorotation Accidents (all types)	Engine/mission mismatch Inadequate procedures Exceeded H-V envelope Accelerated engine wear Inhospitable terrain Restricted visibility, IMC Low inertia rotor blade Inadequate training Altitude data not avail.	Engine monitoring system.....	3	}
			Maintenance improvements.....	2	
			Engine reliability improvements....	5	
			Mission profile changes.....	1	
			Procedures.....	2	
			Training.....	2	
			Rotor design changes.....	5	
			Workload Reductions.....	3	
			Instrumentation.....	3	
			Displays.....	3	
Radar altimetry system.....	3				
TOTAL.....	32				
Pilot Failed to Maintain Rotor RPM	Student Pilot Lost Control of Helicopter Lost RPM and Directional Control Unanticipated Yaw Lost Directional Control of Helicopter	Unfamiliarity with A/C Overconfidence Training Certification Winds, high power required Operating at max G.W. Wind Data not Available Density alt data not avail. Nonstandard controls Uncorrelated controls	Certification Reqmts (instructor)....	4	}
			Standard throttle controls.....	3	
			Rotor Design.....	5	
			Training.....	2	
			Proficiency req'm'ts (pilots).....	4	
			Instrumentation.....	3	
			Displays.....	3	
			Reporting.....	1	
			Controls (anti torque).....	3	
			TOTAL.....	28	

Table 4.1 Summary of Hazards of Helicopter Operations and Root Causes of Helicopter Accidents (Continued)

NTSB Category	How Failed (Hazards)	Why Failed (Root Causes)	Remedies	Degree of Difficulty	Rank
Pilot Failed to See and Avoid Objects	Pilot could not see objects	Visibility Glare Distortion	Aircraft design	5	3
	Pilot could not avoid objects	Unmarked wires Inattention No ground crew Impaired judgement Fatigue	Procedures Mission Instrumentation Displays Workload Duty cycle TOTAL	2 1 3 3 3 1 18	
Inadequate Preflight Preparation and/or Planning	Failed to insure sufficient fuel	Impaired judgement Fatigue	Training	2	4
	Ignored low fuel warning light	Overconfidence Economic pressure Get-home-itis Mistrust of fuel gauges Complacency WX information not available Icing Density altitude	Duty Cycle Procedures Instrumentation Displays Mission Profile Reporting TOTAL	1 2 3 3 1 1 13	
Inadequate performance of external loads	Did not preflight Aircraft				
	Inadequate performance Planning	Could not monitor Did not monitor			

#### 4.3 OTHER SIGNIFICANT FINDINGS

- o The FAA Airmen Certificate Registry is influenced by inclusion of a significant number of active and inactive military pilots who do not engage in civil helicopter flights. The extent of that bias is unknown, although it is known that the vast majority of pilots who receive FAA helicopter ratings do so while on active duty. Moreover, nearly all of these pilots receive commercial/instrument ratings which may tend to inflate the apparent experience levels of pilots engaged in civil helicopter flight. An investigation into these effects should be conducted, with a final goal of separating civil and military pilots within the existing registry and/or identifying and analyzing the effect of their inclusion.
  
- o The NTSB reports, alone, are not adequate for the establishment of root causes of helicopter accidents nor are these reports sufficient for the development of criteria and/or corrective actions to preclude future accidents. A summary of known problem areas includes:
  - 1) Limited rotary wing investigation experience.
  - 2) Not investigating rotary wing accidents with the same intensity that fixed-wing accidents are investigated.
  - 3) Limited helicopter expertise (this is improving with recent helicopter familiarization training).
  - 4) Considerable number of "desk top" audits as opposed to field investigations.

The goal of future helicopter accidents investigations should be to employ techniques and methodologies to reduce both the hazards associated with helicopter operations and the accident rate.

A model for future helicopter accident investigations is the Ricketson 3W approach which focuses the investigation on:

- |                            |                                       |
|----------------------------|---------------------------------------|
| o What happened            | Task Error,<br>Failure or Malfunction |
| o What caused it to happen | System Inadequacies                   |
| o What to do about it      | Remedial Measures                     |

- o The pilot's responses to hazards survey indicated lack of confidence in the National Airspace System's (NAS) ability to effectively handle helicopter operations. The pilots were confident that the system provided sufficient separation services but that there were inefficiencies in how helicopter flights were handled in the NAS. When asked what those inefficiencies were, the pilots cited fixed-wing traffic patterns, marginal visibility operations and holding patterns. In short, they would rather fly low and avoid the system to the greatest extent possible.
  
- o The most common and forceful response to the question of why they choose to fly at low altitude was, surprisingly, related directly to avenues of escape for in-flight emergencies. Pilots consciously choose to fly at low altitude, fully aware that that choice limits the ability to complete an autorotative landing. Low altitudes provide an improved margin of safety in the event of a more dangerous in-flight emergency. That emergency is failure of the transmission. Unlike an engine failure, if the transmission seizes, the pilot can do virtually nothing to prevent an accident. Moreover, a transmission failure during cruise is nearly always fatal. Pilots faced with this choice stay at low altitude since it means they can get on the ground more quickly at the first indication of incipient failure (transmission oil pressure, temperature, transmission chip detector lights, low rotor rpm). Although the accident/incident data base does not substantiate transmission failure as being a significant factor, the pilots view this failure mode with far more fatalism than they do an engine failure.
  
- o Commercial helicopter pilots, as a group, are far less diligent in their performance of preflight planning and preparation tasks. This result is especially surprising since a substantial number of the commercial helicopter pilots are engaged in offshore operations, as employees of major helicopter operators. It is generally considered that these operators have standardized operational procedures which are strictly adhered to by the pilot. However, the pilot supplied and accident data does not support this assumption.

A surprising omission on the part of the commercial operators is seen in the low incidence of selection of three flight planning tasks 1) Performance planning, 2) in ground effect (IGE) hover checks and 3) performance planning for out of ground effort (OGE) hover performance. This is surprising since the commercial pilots reported the greatest percentage of flight missions in which their aircraft was operated in excess of 90 percent of maximum gross weight. Commercial pilots reported that they flew in excess of 88 percent of all their flight missions in aircraft loaded to more than 90 percent of maximum gross weight.

- o The survey pilots were asked to indicate their probable course of action if they determined that the time available was insufficient to perform all of the necessary preflight tasks. The pilots were given two options: 1) Perform the most necessary tasks and make the scheduled departure. and 2) Inform the dispatcher that you cannot make the scheduled departure. and perform all of the preflight tasks. The group response for this question was approximately 4:1 in favor of the first option; to make the scheduled departure.
  
- o A correlation was noted between the percent of "Most Prevalent Detailed Accident Causes" for both helicopter and fixed-wing general aviation accidents, despite the differing accident rates for FW & RW attributed to each cause. The correlation indicates that the similarities may be the result of a bias introduced by investigators who are typically fixed-wing oriented, and bring to helicopter accidents a framework of thinking which is appropriate to the fixed-wing environment, but not to helicopters. Emphasis should be placed in coupling investigator training to the types accidents that they are assigned to investigate. If it is found that there is insufficient helicopter experience on the investigating staff, actions should be taken to increase helicopter representation within the NTSB.

#### 4.4 SUMMARY OF PILOT PERSPECTIVES OF ROOT CAUSES OF HELICOPTER ACCIDENTS

- o Pilots are largely aware of their own contribution to the high rate of helicopter accidents. In fact they rated pilot error as the most frequent factor in helicopter accidents, stating that it is the cause of 38 percent of the accidents.
  
- o Pilots tend to believe that their helicopters and its systems are only responsible for about 22 percent of accidents. NTSB cites equipment malfunction as the cause of 35 percent of all accidents.
  
- o Pilots tend to overestimate the importance of instrument meteorological conditions as a factor in aircraft accidents. This is largely the result of their own lack of confidence in their equipment when exposed to instrument conditions and lack of experience and proficiency.

- o Pilots' recommendations for future R&D requirements focused on safety, vehicle design and human factors as the three most important areas for both current and future rotorcraft. Several of their most notable recommendations are:
  - "...The largest area (for safety improvement) is human engineering i.e., cockpit comfort, equipment set up that would not allow its misinterpretation or misuse. Standardize controls and switches".
  - "...hazard -icing. We need a helicopter certified for flight in known icing conditions".
  - "It may appear that I have "copped out" on all the answers by advocating a fully automated system with a technician to monitor. However, almost all crashes, near crashes, over torques, over temps, missed approaches, traffic backups and all other "villains" of aviation activity (could be eliminated) if one could eliminate (the pilot)".
  
- o Two comments made by the pilots are important since they address the root cause of pilot error accidents.
  - "I feel today's most serious hazard is the human factor, whether it be pride (get the job done no matter what), "get home-it is", lack of training, just plain ignorance, partial or total disregard for safety, etc. Once again, in the unrealistic event of total automation (technician monitored) you would eliminate the "subjective" influence and "bending of the rules"."
  - "Safety in the air starts on the ground with proper preflight procedures. A pilot cannot fly ahead of his aircraft safely when he takes off ill prepared and already behind the aircraft. Coupled with the environment, a pilot cannot make up the lost preflight ground (time) and still expect a safe flight on a regular basis."

#### 4.5 SUMMARY OF RESEARCH RECOMMENDATIONS

Several areas requiring continued research were identified as a result of this analysis. It is in the best interest of the manufacturers, the FAA and the operators to pursue the funding and manpower required to further explore the costs and potential benefits in as many of these areas as possible. In order of relative importance, the recommended research areas are:

- o Engine reliability improvements (improved engine life cycle procedures and TBOs based on helicopter mission and engine cycle characteristics).
- o Improved autorotation characteristics (high inertia rotorblade optimized for improved handling qualities and reduced pilot workload during autorotation).
- o Improve autorotation training procedures (and possibly mandate initial and recurrency requirements).
- o Development of wire and wire like object detection system.
- o Engine conditioning monitoring system (in conjunction with on condition maintenance and improved maintenance procedures).
- o Develop a power available vs power required instrumentation system and display.
- o Multisensor (FLIR, LLTV, Laser, etc.) system for flying in reduced visibility and to provide all weather landing capability.
- o Develop a radar altimetry system compensated for bank angle to provide accurate height above touchdown data.
- o Develop an improved training syllabus on unanticipated yaw (wind effects, low RPM, inadvertent high power required, maneuvering in winds).
- o Develop and require decision making training and stress management training materials (Continue the work of Reference 18 as applied to helicopter pilot training).
- o Expand the Air Traffic Control Training Syllabus to include helicopter traffic management.
- o Develop One Engine Inoperative (OEI) standards to ensure the helicopter has sufficient power to continue flight and make a safe landing.



#### REFERENCES

1. "Special Study - Review of Rotorcraft Accidents 1977-1979", National Transportation Safety Board, Report No. NTSB-AAS-81-1, August 11, 1981.
2. "Annual Review of Aircraft Accident Data", U.S. General Aviation Calendar Year 1980, NTSB/ARG-84/01.
3. Ontiveros, Robert J., "General Aviation Safety Research Issues", Federal Aviation Administration, DOT/FAA/CT-83/6, June, 1983.
4. "The Influence of Total Flight Time, Recent Flight Time and Age on Pilot Accident Rates" Federal Aviation Administration, Safety Analysis Division, June 1983.
5. Skjenna, O.W, M.D., "Cause Factor: Human A Treatise on Rotary Wing Human Factors", Minister of National Health and Welfare, Canada, 1981.
6. "Human Factors Aspects of Aircraft Accidents", AGARD Lecture - Series No. 125.
7. "Army Aviation Accidents", U.S. Army Safety Center, 1979-1983.
8. "Lessons Learned from FY82 U.S. Army Aviation Mishaps", Analysis and Research Division, U.S. Army Safety Center.
9. Fox, Roy, "Reporting Helicopter Flight Hours: Why Care?", Rotor Breeze Bell Helicopter Textron, April-May 1985.
10. "Helicopter Annual", Helicopter Association International, January 1985, 3rd edition.
11. "U.S. Civil Helicopter Statistics, 1983", Insured Aircraft Title Service, 1983.
12. "Current Rotorcraft Fleet and Airmen Characteristics, Phase I Report", COMSIS Corporation, 1983.
13. "FAA Aviation Forecasts Fiscal Years 1985-1996", Federal Aviation Administration, Office of Aviation Policy, February 1985.
14. "Upton, H.W., Boen, G.E., and Moore, J., "Investigation of Advanced Navigation and Guidance System Concepts for All Weather Rotorcraft Operations", by Bell Helicopter Textron for NASA, Report No. CR-166274, September 1981.

REFERENCES (Continued)

15. Taylor, F.R., "Helicopter User Survey: Traffic Alert and Collision Avoidance System (TCAS)" by Systems Control Technology, Inc. for FAA, Report No. DOT/FAA/PM-85/6, August 1984.
16. Fox, Roy, "Relative Risk: The True Measure of Safety", Hospital Aviation, February 1984.
17. Federal Register, Vol. 49, No. 89, Monday, May 7, 1984.
18. Hornack, P.W., "Aeronautical Decision Making (ADM): A New Concept in Pilot Training", Airport Services Management, September 1985.

APPENDIX A

DETAILED METHODOLOGY FOR BOTH  
PHASE ONE AND PHASE TWO  
OF THE OPERATOR'S SURVEY

## A.0

## METHOD OF APPROACH

The material presented in this section provides an overall understanding of the methodology used in Phase One and Phase Two of this study of civil helicopter operations. In particular, the following discussion provides the highlights, of the issues involved, the inputs required and the outputs for each phase.

### A.1 TECHNICAL AND OPERATIONAL CIVIL HELICOPTER ISSUES

The investigation of root causes was a task in the IFR Helicopter Certification Standards research area of the Helicopter Technical Support Contract (DTFA01-80-C-10080). As a part of that research area, several important technical and operational issues needed to be addressed during the analysis. Table A.1 summarizes those issues which could conceivably produce an increase in pilot error helicopter accidents. These include economic viability, manufacturer developments, certification demands and emerging new technology. All of these factors tend to increase the potential pilot exposure to hazards and root causes of accidents. This section defines and describes those issues in order to provide a focus for the analysis of Section 3.0.

Economic viability requires that the high cost of helicopters and their associated avionic/navigation systems be offset by high utilization in air commerce or corporate activities. This dictates a need for the helicopters and flight crews to be approved for operation in a wide range of weather environments, including instrument meteorological conditions (IMC) and icing. In addition, the common use of helicopters in low altitude, low visibility flying is more prevalent and demanding than instrument flight.

The user industries, having developed operational dependence on the helicopter for logistical support, have a need for schedule regularity. In other cases, where medical evacuation or rescue operations are urgently needed, the ability to operate in an expanded set of weather conditions is essential. These economic, consumer and humanitarian considerations underscore the need for improved and expanded criteria for application to helicopter certification and operation.

Helicopter manufacturers, planning increased IMC capability in new helicopter types under development, are employing new technologies and increased system sophistication in the new designs. In addition, numerous aircraft and avionics manufacturers are anxious to respond to the operational need for a single-pilot IFR certified helicopter.

These developments indicate that increased numbers of applications for IFR Supplemental Type Certification (STC) and initial IFR Type Certification for helicopters can be expected in the near future. Many of these will be requesting reduced restrictions to IFR operations involving the use of newly developed equipment/systems. The task of maintaining a

Table A.1 Technical and Operational Issues Potentially Increasing Pilot Error Accident Rates

---

o	ECONOMIC VIABILITY	<ul style="list-style-type: none"> <li>- High Utilization Rates</li> <li>- "On-Demand" Use</li> <li>- Schedule Reliability</li> <li>- Humanitarian Demands</li> </ul>	<ul style="list-style-type: none"> <li>Special VFR</li> <li>IMC</li> <li>Icing</li> <li>Disasters</li> </ul>
o	MANUFACTURER DEVELOPMENTS	<ul style="list-style-type: none"> <li>- Increased IMC Capability</li> <li>- Stabilization &amp; Avionics Sophistication</li> <li>- Single Pilot IFR</li> </ul>	
o	CERTIFICATION DEMANDS	<ul style="list-style-type: none"> <li>- Increased Demand for IFR STC's and Type Certification</li> <li>- Reduced IFR Restrictions</li> <li>- Maintain Safety</li> </ul>	
o	EMERGING TECHNOLOGY	<ul style="list-style-type: none"> <li>- Active Flight Controls</li> <li>- Digital Electronic Displays</li> <li>- Software Dependent Designs</li> <li>- Multisensor Navigation</li> </ul>	

---

definable level of safety, which is the responsibility of the FAA, is greatly complicated by the myriad of stability augmentation systems, automatic stability equipments, cockpit displays, flight directors, navigation aids, and navigation coupler systems.

Emerging technological advances in active flight controls for improved stability as well as vibration and load alleviation, digital electronics, multiplex data buses, solid state displays, etc., require new reliability and functional assessment methodology, i.e., comprehensive system safety hazard analysis, i.e., failure mode and effects, fault tree, sneak circuit and random failure analyses. Coordinated assessment in these areas was the primary objective of this investigation. The principal output of this study was an operational evaluation and prioritization of the relative impact of each of these areas on level of safety. This prioritization, based on user's experience, allows the FAA to establish and sort out viable future technology, engineering and development programs and funding levels.

The helicopter operations survey performed to support this research provided the necessary background research and analysis to assure that: the state-of-the-art in helicopter stability and control, cockpit configuration and displays; simulation technology, aircrew workload

evaluation techniques; and the real world hazards of instrument flight were collectively considered.

Specific elements of the survey included:

- o Identification of the hazards of instrument flight through an analysis of historical rotorcraft accident reports and statistics.
- o Identification of the operational environment (including hazard definition and pilot workloads) associated with instrument flight in helicopters.
- o Identification of human factors problems of helicopter operations.
- o Evaluation of proposed flying qualities/workload assessment schemes for applicability in helicopter certification.

This research task utilized an accident cause factor analysis using National Transportation Safety Board accident data and field surveys involving operator interviews, manufacturer surveys, hazard definition and workload measurements. Throughout the survey emphasis was placed on simplified concepts in the display and control systems area, particularly as they pertain to small helicopters. The intent of this approach was to minimize the impact of high cost electronic systems currently used on large helicopters. The application of simple rate dampening systems, wing leveler type devices, artificial horizons, etc. were identified as examples of these simplified concepts.

#### A.2 OVERVIEW OF PHASE ONE AND PHASE TWO PLANS

The primary elements of the Phase One research plan were the historical literature survey, the field survey of samples of helicopter operators, the methodology for identifying information needs, the data acquisition plan and the interim report. The relationship of these primary elements to the required research tasks of Phase One and the flow of information between these tasks are illustrated in Figure A.1. As shown in Figure A.1 Tasks E-1(a) and E-1(b) were initiated in parallel at the go-ahead date for this effort. The initial task E-1(a) effort, the literature evaluation, provided an historical perspective on helicopter activities, operator needs and a baseline for Safety/Reliability issues. This literature survey relied on the review of existing reports, accident records and civil operating scenarios. This preliminary information was used as a data base to be expanded by knowledge gained from the preliminary interviews (E-1(d)). As the data base developed, the requirements for operator survey information were streamlined (E-1(c)). These requirements were used to develop a specific operator survey methodology unique to the goals of this project.

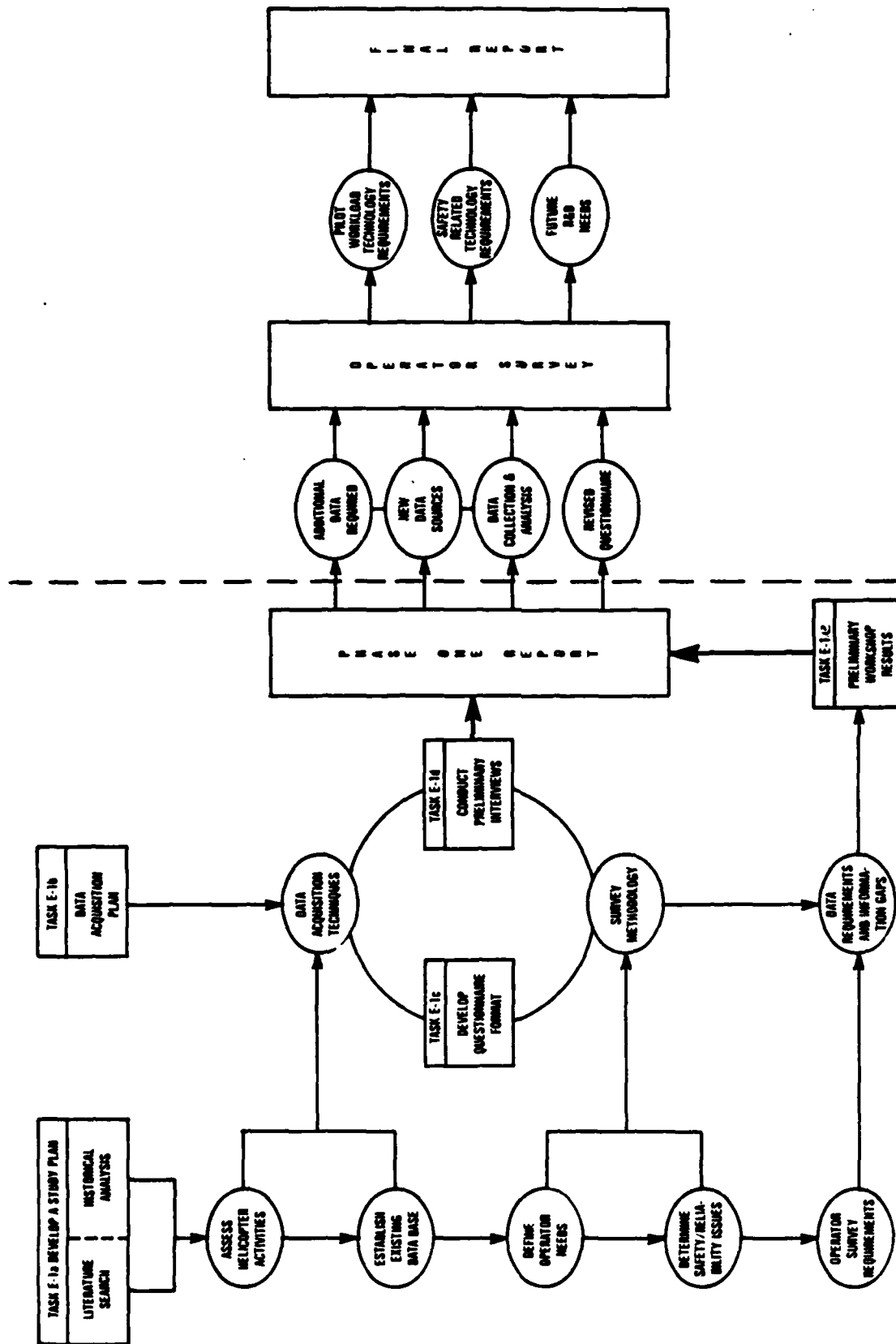

Figure A.1 Overview of Information Flow, Data Requirements and Project Tasks for Phase One

The second task of this project involved developing a data acquisition plan. As illustrated in Figure A.1, this plan consisted of three primary segments. First, the gaps in current information and data were defined based on the assessment of past and forecast helicopter activities. Second, specific data acquisition techniques required to fill these gaps were designed using knowledge of the operators' needs, especially focusing on those needs which directly impacted safety and reliability of flight. The latter needs included an assessment of pilot workload issues as affected by both equipment malfunctions (or failures) and the psychological and physiological workload issues, which are related to helicopter design or operational deficiencies affecting safety of flight. Finally, the additional data requirements and the data acquisition techniques were largely fulfilled by the survey methodology portion of the data acquisition plan. The Phase One methodology for the survey is discussed in detail in Section A.2.2. This methodology included identification of specific information sources in the manufacturing industry and the operator industry which were required to satisfy known information gaps. A deliberate effort was made (as a part of the initial survey methodology) to determine the key individuals at the management, pilot, copilot and maintenance level necessary to provide the type of information required to fill the data gaps identified.

#### A.2.1 Phase One Method of Approach by Task

In order to be brief, the Statement of Work for this project will not be restated here. However, the task statements included in this Section of the project description are fully responsive to the Statement of Work of Contract No. DTFA01-80-C-10080, Task E-1 - "Plan For Helicopter Operators Survey".

#### TASK E-1(a) -- DEVELOP A STUDY PLAN

The work performed in this task focused on refinement and development of the preliminary project plan developed and submitted during the first two months of this research. In particular, this task assembled all available information relative to civil helicopter activities. This included historical data as well as projections to 1990. The most authoritative data sources concerning past, present and future helicopter activities were sub-divided into three categories or types. These were government sources, industry national/regional associations and literature/periodical indices or sources. The number and types of known sources for each of these categories is shown in Table A.2. Detailed analysis of data from 17 of the 41 sources listed was performed during Phase One. Pertinent material available from these sources was used to identify a comprehensive set of civil helicopter operational uses. These were then categorized by helicopter type cutting across the lines of helicopter operator classification. For each mission category/helicopter type combination, safety hazards, current pilot workload problems, maintenance and design problems were defined. Where possible, the same type of analysis was provided for future or projected helicopter



Table A.2 Information Sources for Pilot Error Accident Survey

**A. GOVERNMENT SOURCES:**

1.	National Transportation Safety Board	-	NTSB*
2.	Aviation Safety Reporting System	-	NASA*
3.	Department of Transportation	-	DOT*
4.	Department of Commerce	-	DOC
5.	Federal Aviation Administration	-	FAA*
6.	United States Coast Guard	-	USCG
7.	Office of Aircraft Services	-	DOI
8.	U.S. Park Service	-	USPS
9.	U.S. Forest Service	-	USFS
10.	U.S. Customs	-	USC
11.	Drug Enforcement Agency	-	DEA
12.	Federal Emergency Management Agency	-	FEMA
13.	Federal Bureau of Investigation	-	FBI
14.	U.S. Park Police	-	USPP*
15.	Law Enforcement Assistance Administration	-	LEAA

**B. INDUSTRY NATIONAL/REGIONAL ASSOCIATIONS:**

1.	Helicopter Association International	-	HAI*
2.	American Helicopter Society	-	AHS*
3.	Aerospace Industries Association	-	AIA*
4.	Airborne Law Enforcement Association	-	ALEA
5.	National Association for Search and Rescue	-	NASAR
6.	National Association of Fire Chiefs	-	NAFC
7.	Aero Medical Transport Association	-	AMTA
8.	American Institute of Aeronautics and Astronautics	-	AIAA*
9.	Mountain Rescue Association	-	MRA
10.	Appalachian Helicopter Pilots Association	-	AHPA
11.	Professional Helicopter/Pilots Association	-	PHPA
12.	Eastern Region Helicopter Council	-	ERHC*
13.	Helicopter Safety Advisory Committee	-	HSAC*
14.	Florida Helicopter Pilots Association	-	FHPA
15.	State Agencies (Dept. of Aviation, Environmental Control, Emergency Medical Services, etc.)	-	STATE
16.	County Agencies (Civil Defense, Disaster Relief, Sheriff's Office, Fire Department)	-	COUNTY
17.	City Agencies (Police Departments, Hospital Centers, Fire Departments)	-	LOCAL

**C. LITERATURE/PERIODICAL SEARCH**

1.	National Technical Information System	-	NTIS*
2.	NASA Library System	-	STARS*
3.	Rotor and Wing International	-	R&WI*
4.	Professional Pilot	-	PROP*
5.	AOPA Pilot	-	AOPA*
6.	Business & Commercial Aviation	-	BCA*
7.	Civil Aviation Authority Occurrence Digest	-	CAA
8.	Society of Automotive Engineers Abstracts	-	SAE
9.	U.S. Army Flight Fax	-	USA

\*Indicates data sources used during Phase One

missions. Using this technique it was possible to provide the basic foundation of the remaining elements of this task. These elements include:

- 1) Formulating a helicopter operators data base
- 2) Identifying information gaps
- 3) Determining the alternative sources for missing information
- 4) Determining the characteristics of pilot workload and cockpit task loading which may impact flight safety.

Phase Two of the Helicopter Operations Survey Program was designed for two parallel purposes. First, it provided the filling in those areas where there was a dearth of published results. Second, it provided up to date operational (field) knowledge which enhanced and calibrated the published data base.

#### TASK E-1(b) -- Develop a Data Acquisition Plan

Considering the diversity of the civil helicopter industry, the large number of operators, and the significant variation in types of helicopters currently used, the major objectives of this task were formulated as: first, to define both qualitatively and quantitatively the character of civil helicopter operations including the operational needs, technical problems and desired vehicle characteristics of each user group vs. mission type. Second, to analyze and organize this wide-ranging set of information into a matrix of mission-related requirements to reduce pilot workload, to improve mission effectiveness and reliability and to enhance safety.

The specific objectives for this task were stated in the Statement of Work as:

- 1) Identify data requirements
- 2) Identify data acquisition equipment
- 3) Determine personnel requirements
- 4) Determine data reduction and presentation
- 5) Develop cost estimates

These objectives were satisfied in different ways. The first objective was discussed thoroughly in Task E-1(a). Basically, data requirements and information gaps were determined from the literature search and historical data analysis. Objectives two and three were satisfied primarily by information and data gathered during the Phase Two operator survey. The data reduction and presentation requirements of objective four were determined in an iterative manner with the FAA

technical monitor throughout the program. Finally, objective five, cost estimates for the data gathering, were provided in the form of a business management proposal using conventional Optional Form 60. The development of the data acquisition plan for all five of these objectives was straightforward and similar plans have been developed on many SCT programs. However, the importance of these five objectives related to the Phase Two operator survey warrants further discussion and understanding of the survey methodology, the questionnaire format and the interview procedures.

#### TASK E-1(c) -- Develop Questionnaire Format

The Phase Two civil helicopter operations survey was structured to obtain a balanced representation of operators and geographic areas within the three major categories of Commercial, Corporate, and Public Service. Since these interviews will be the foundation used to formulate technology requirements for reducing pilot workload, improving safety and specifying future R&D needs, a well-designed and detailed interview process was critical to the successful completion of this program. The interview process was structured to include the following key considerations:

- o A technique for defining the working level individual(s) who is (are) most qualified to provide the desired information.
- o A method for minimizing the communication problems between operator/user personnel and engineers representing the technical community.
- o A means for obtaining a minimum set of standard information from each interview.

The method of approach to achieve the stated objectives of this task was a modified Delphi technique. This method provided optimum pre-interview information exchange, early and continuous feedback of data and included loop closure and cross-checking of the oral and written information obtained until an expert consensus was reached. The method is summarized in Figure A.2. The initial step in designing the interview process was to develop a comprehensive list of user/operators who are candidates to be interviewed. This compilation was correlated by major civil helicopter category, user agency and geographic region. The contractual portion of initial contact also included determination of associated working professionals such as doctors, police chiefs, pilots, etc. In addition to these user categories and associated professions, the HAI, AHS and ALEA membership directories, the Department of Interior's list of helicopter operators and other similar sources were used to identify helicopter operators as candidate interviewees. The initial phone contact technique shown in Figure A.2 was used to screen and select those to be interviewed.

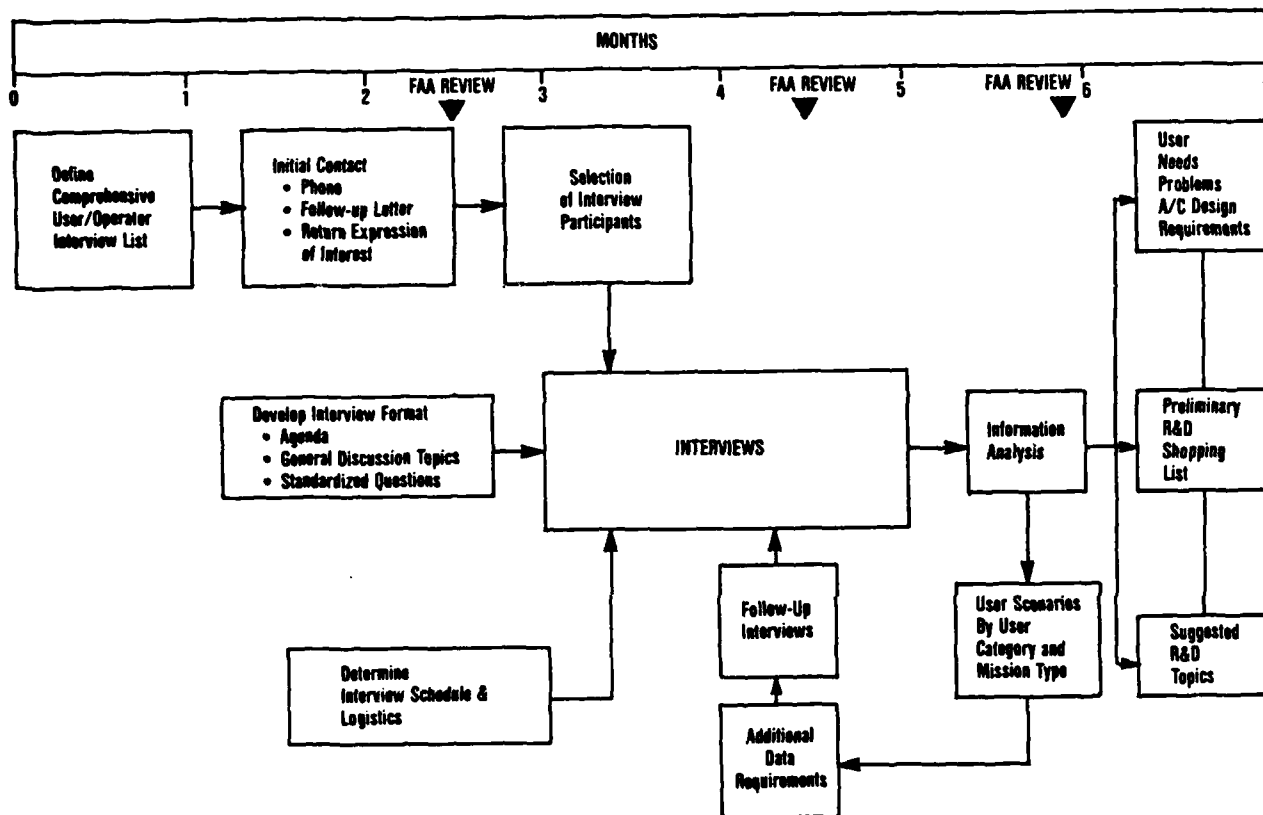

Figure A.2 Methodology and Schedule for the Operator Survey

The second step in designing a successful operator survey was to establish an interview structure or format which insured that a common data base of information was obtained from each interview. To this end, a preliminary interview format, agenda, and list of topics for discussion were developed during Phase One of the program. This interview information package (Appendix B) was mailed out to prospective interviewees during Phase One after an initial phone contact. This package continued to be used during Phase Two. The purpose of this package was to identify the source of the study, its scope and purpose. In addition, the detailed meeting agenda and list of topics served two purposes. First, it acquainted the interviewees with what was expected at the interview. Second, it served to constrain the length of the interview and expedite the information exchange.

In addition to the general information package, each interviewee was asked to fill out a brief "Safety R&D Requirements Survey" and a detailed "Helicopter Operators Survey". Appendix C provides samples of each of the survey forms. These surveys were used for defining safety related helicopter design criteria and technology needs for the next generation of civil helicopters and to obtain detailed user data in the areas of:

- o Mission Requirements
- o Equipment Requirements and Limitations
- o Aircraft Utilization Data and Availability Rates
- o Safety Hazards
- o Number and Type of Aircraft
- o Maintenance and Reliability Profiles
- o Operational Problems
- o Technology Improvements

The third step required in designing a successful and informative operators survey was to insure that the appropriate working level person(s) were identified during the interview for further discussions and possibly a follow-up interview either by phone or in person. To accomplish this goal, the interview agenda established (Appendix B) included a group meeting where the person(s) initially contacted were asked to invite "appropriate" associated professionals with responsibility at all levels in the chain of civil helicopters being investigated. During this group meeting, SCT presented a brief (15-30 min) description of the program. This program briefing was followed by discussions and ad hoc questions in the general topics of interest. At this point, a set of standardized questions were passed out and the group participants were asked to "fill in the blanks". These questions were brief and involved mostly (90%) multiple choice answers (with space provided for written explanation or exceptions). These surveys were then collected and the material discussed by the group. At the end of this discussion, specific one-on-one meetings were set up with cognizant working-level users, operators and professionals.

TASK E-1(d) -- Conduct Preliminary Interviews

At the suggestion of the contract technical monitor, a series of preliminary interviews were conducted during Phase One. These preliminary interviews were conducted in order to develop and refine the user group interviewing technique, and to obtain an understanding of the variability in size, quality and operational philosophy in the primary civil helicopter user community. These interviews also provided an early opportunity to begin sampling the data available from the users and the level of interest/cooperation to be expected. The cross section of users interviewed during these preliminary sessions included:

- o Operators: HAI, Allied Corp., CBS Inc., Port Authority of New York & New Jersey, Executive Air Fleet, Colgate Palmolive Co., Ronson Aviation
- o Manufactures: Sikorsky, UTC, Bell, Aerospatiale
- o Researchers: Federal Aviation Administration Technical Center, International Air Safety, LTD.
- o Flight Schools: Flight Safety International
- o FAA Offices: Safety Analysis Division, Safety Data Branch, Eastern Region
- o NTSB: Bureau of Technology

These interviews were conducted from May 1981 through October 1981. A total of four interview trips were taken as follows:

<u>Trip No.</u>	<u>Duration</u>	<u>Location</u>	<u>Agency</u>
1.	5/11/81 to 5/15/81	East Coast	HAI, FAA, FAATC, FAA Eastern Region, International Flight Safety, LTD.
2.	6/24/81 to 6/26/81	East and Northeast	Eastern Region Helicopter Council, Sikorsky, New York Helicopters
3.	7/30/81 to 7/31/81	Southwest	Bell, Aerospatiale, Flight Safety International
4.	10/15/81	Washington, D.C.	NTSB

The first East Coast trip, in May 1981, was used to provide baseline safety information from the Helicopter Association International (operators), the FAA (Safety Analysis Division), the FAATC (Systems Test and Evaluation Division) and Flight Safety International (accident

investigation experts). A list of persons interviewed during these meetings is provided in Table A.3.

The primary information collected included:

1. HAI Helicopter Accident Statistics and Safety Bulletins 1978-1980.
2. A Review of the FAA's Accident/Incident Data System.
3. An Assessment of Service Difficulty Reports for 1980 (all helicopter types).
4. An FAA Assessment of Rotorcraft Accident Data 1976-1979.
5. Operational Familiarization with Helicopter ATC in the Congested N.Y. Metropolitan Airspace.
6. A Working Agreement with the FAA's Safety Data Branch for Data Access.
7. A Review of Interview Procedures, Required Data, and Analysis Techniques by Flight Safety International.

The second trip consisted of a preliminary interview of a representative cross-section of corporate pilots, a manufacturer, and a helicopter air carrier. These preliminary interviews were conducted as described in the previous write-up for Task E-1(c). The preliminary Safety R&D Requirements Survey and Helicopter Operations Survey were described, discussed and distributed to these three groups. The results of these preliminary interviews are discussed in Sections 3.2 and 3.3 which follow. A detailed list of personnel interviewed and their affiliation is presented in Table A.4.

The third data collection effort was to the Southwest in July 1981. This trip was planned to gather more detailed and additional data from two helicopter manufacturers and one flight training school. Formal interview procedures were not used. Rather a request for information (written) was submitted, the meetings scheduled and the manufacturers were relied upon to provide recent experience and analysis of accident, maintenance and reliability aspects for their models. Bell Helicopter Textron provided excellent briefing material and draft reports on "Part 135 Helicopter Safety Survey Study: NPRM 78-3B-Effectiveness" "Inclement Meteorological Conditions Analysis" and "Assessment of Historical and Projected Segments of U.S. and World Civil and Military

Table A.3 Initial East Coast Data Collection/Interview Trip  
(11 May 1981 to 15 May 1981)

NAME	EMPLOYING ORGANIZATION & ADDRESS	PHONE
Steve Schuldenfrei Susan Danker	Helicopter Association International 1110 Vermont Avenue, N.W. Suite 430 Washington, D.C. 20005	(202) 466-2420
Ed Graves, ASF-220	Federal Aviation Administration Safety Analysis Division Room 301D 800 Independence Avenue, S.W. Washington, D.C. 20590	(202) 426-8256
Ernie Quellette, AFO Dick Hall, AFO	Flight Standards National Field Office P.O. Box 25082 Oklahoma City, Oklahoma 73125	(405) 686-4391
Bob Pursel, ACT-100B Navigation Program Manager	Federal Aviation Administration Technical Center Atlantic City Airport Atlantic City, New Jersey 08405	(609) 641-8200 Ext. 3918
John Heurtley, ACT-100	Federal Aviation Administration Technical Center Systems Test and Evaluation Division Atlantic City Airport Atlantic City, New Jersey 08405	(609) 641-8200
Jim Knoetgen	Federal Aviation Administration Eastern Region JFK Airport Jamaica, New York 11430	(212) 995-3390
Ed Hutcheson Bruce Webster	International Air Safety LTD 4460 Kenmore Avenue Alexandria, Virginia 22304	(703) 370-1970



Table A.4 Eastern Region Helicopter Council Meeting  
(23 June 1981)

NAME	EMPLOYING ORGANIZATION & ADDRESS	PHONE
Ed McConkey	Systems Control Technology, Inc. 2326 S. Congress Avenue-Suite 2A West Palm Beach, Florida 33406	(305) 968-4200
Ed Newton	Allied Corporation Morristown Municipal Airport Morristown, New Jersey 07960	(201) 995-3390
Jim Knoetgen	Federal Aviation Administration Eastern Region JFK Airport Jamaica, New York 11430	(212) 995-3390
Ray Hilton	Federal Aviation Administration 400 7th Street, S.W. Washington, D.C. 20590	(202) 426-3406
Jack Mullen	CBS, Inc. LaGuardia Airport Flushing, New York 11371	(212) 651-3537
Jay McGowan	Port Authority of New York & New Jersey - Heliport 1 World Trade Center New York, New York 10048	(201) 288-2761
Paul G. Stringer ACT-306	Federal Aviation Administration Technical Center Atlantic City Airport Atlantic City, New Jersey 08405	(609) 641-8200 Ext. 3064
Robert Truckenmiller	Executive Air Fleet 118 Billy Diehl Road Teterboro, New Jersey 07608	(201) 440-0200
George M. Jones	Colgate-Palmolive Co. Hangar 12 Newark Airport Newark, New Jersey 07114	(201) 961-5766

Table A.4 Meeting Held at Sikorsky Aircraft  
(26 June 1981)

(continued)

NAME	EMPLOYING ORGANIZATION & ADDRESS	PHONE
Raymond Syms	Ronson Aviation 11 West 16 <sup>th</sup> Street Linden, New Jersey 07036	(201) 862-0392
Robert Chaves	New York Helicopters North Avenue Garden City, New York 11530	(212) 895-1681
Perry Young	New York Helicopters North Avenue Garden City, New York 11530	(212) 895-1681
Ed McConkey	Systems Control Technology, Inc. 2326 S. Congress Avenue-Suite 2A West Palm Beach, Florida 33406	(305) 968-4200
Jim Knoetgen	Federal Aviation Administration Eastern Region JFK Airport Jamaica, New York 11430	(212) 995-3390
Paul G. Stringer ACT-306	Federal Aviation Administration Technical Center Atlantic City Airport Atlantic City, New Jersey 08405	(609) 641-8200 Ext. 3064
John C. Parker	UTC Pilot Rentschler Airport East Hartford, Connecticut 06108	(203) 565-3596
Herb Slaughter Manager	Sikorsky Aircraft Product Integrity Engineering North Main Street Stratford, Connecticut 06497	(203) 386-6645
Chris Fuller Chief	Sikorsky Aircraft Systems Safety North Main Street Stratford, Connecticut 06497	(203) 386-5174

---

Table A.4 Meeting Held at Sikorsky Aircraft  
(26 June 1981)

(continued)

---

C.M. Bertone Chief	Sikorsky Aircraft Human Factors Engineers North Main Street Stratford, Connecticut 06497	(203) 386-5174
Dick Stutz Manager	Sikorsky Aircraft Helicopter Operations Division North Main Street Stratford, Connecticut 06497	(203) 386-5549
Charlie Evans	Sikorsky Aircraft Pilot's Office North Main Street Stratford, Connecticut 06497	(203) 386-6497
Bob Klingloff Chief	Sikorsky Aircraft Handling Qualities North Main Street Stratford, Connecticut 06497	(203) 386-4328
Tom Sheehy Chief	Sikorsky Aircraft Aerodynamics North Main Street Stratford, Connecticut 06497	(203) 386-4661

---

Rotorcraft Markets 1960-1990". Aerospatiale Helicopter Corporation vigorously supported the objectives and thrust of Helicopter Operations Survey, but was at an early stage in automating their accident, incident and maintenance data base. For this reason, qualitative safety information and hazard definitions were collected from all levels of the corporation from the V.P. for Operations, the Engineering Department, the Safety Department, the Chief Test Pilot and several others. In addition, close coordination with the safety data base development personnel was achievable as a result of this meeting. The detailed list of interviewees for the Southwest trip are listed in Table A.5.

The final interview of Phase One was held in Washington, D.C. on October 15, 1981. A meeting was held at the National Transportation Safety Board. The purpose of this meeting was to receive a briefing on, and review the results of, a "Special Study -- Review of Rotorcraft Accidents, 1976-1979". This study had just recently been completed and accepted by the board, however, the report had not been published yet. The breadth and depth of this analysis of four years provided a critical link in the safety analysis, the hazard definition, the pilot workload analysis and the maintenance/reliability analysis of Phase One. Attendees at this meeting included:

Dr. Bernie Loeb	-	NTSB
Mr. Paul Stringer	-	FAATC
Mr. Mike Glynn	-	FAATC
Mr. Richard Adams	-	SCT
Mr. Terrence Connor	-	ACUMENICS

#### TASK E-1(e) -- Preliminary Results Workshop

The purpose of this workshop was to document the results of the preliminary interviews (Task E-1(d)) and to present them with the results of the literature review (Task E-1(a)). This workshop provided the first opportunity to calibrate the Phase One results and either validate or contradict major findings. This workshop was held in June 1982 at the FAA Technical Center, Atlantic City, New Jersey. The workshop included FAA representatives and interested industry observers (approximately 60 attendees total).

#### A.2.2 Phase Two Method of Approach By Task

Once set in the foundation of Phase One, this second phase became a matter of collecting additional data, expanding the geographic distribution of the operator groups surveyed and broadening the number and variety of mission types analyzed. The primary elements of Phase Two were the identification of hazards of helicopter operations, the operational data collection, data analysis and preparation of the final

Table A.5 Southwest Manufacturer Meeting  
(September 1981)

Day One

NAME	EMPLOYING ORGANIZATION & ADDRESS	PHONE
Robert J. Hampton R.C. Buyers L.W. Hartwig	Bell Helicopter Textron 600 E. Hurst Blvd P.O. Box 482 Fort Worth, Texas 76101	(817) 280-2011
Hugh Upton J. Drees R.E.R. Borland	Bell Helicopter Textron 600 E. Hurst Blvd P.O. Box 482 Fort Worth, Texas 76101	(817) 280-2011
J. Goodman Roy Fox Dora Strothers	Bell Helicopter Textron 600 E. Hurst Blvd P.O. Box 482 Fort Worth, Texas 76101	(817) 280-2011
J. Van Gaasbeck R.H. Wheelock H. Coffman	Bell Helicopter Textron 600 E. Hurst Blvd P.O. Box 482 Fort Worth, Texas 76101	(817) 280-2011
Joe Del Balzo Richard I. Adams Paul Stringer John Reed	Federal Aviation Administration Technical Center Atlantic City Airport Atlantic City, New Jersey 08405	(609) 641-8200
Richard J. Adams	Systems Control Technology, Inc. 2326 S. Congress Avenue - Suite 2A West Palm Beach, Florida 33406	(305) 968-4200
John L. Wells	Flight Safety International South Norwood and Trinity Blvd. P.O. Box 819 Hurst, Texas 76053	(817) 282-2557
John Foster	NASA Ames Mofett Field, California 94035	(415) 965-5003

Table A.5 Southwest Manufacturer Meeting  
(September 1981)

(continued)

Day Two

NAME	EMPLOYING ORGANIZATION & ADDRESS	PHONE
Bob Herndon Carl Barber Mel Vigen	Aerospatiale Helicopter Corporation 2701 Forum Drive Grand Prairie, Texas 75051	(214) 641-0000
Dave Shockley Art Wagner G. Aicardi	Aerospatiale Helicopter Corporation 2701 Forum Drive Grand Prairie, Texas 75051	(214) 641-0000
Larry Taylor G.A. Starr Jake Hart	Aerospatiale Helicopter Corporation 2701 Forum Drive Grand Prairie, Texas 75051	(214) 641-0000
Jim Knickerbocker John Snellgrove	Aerospatiale Helicopter Corporation 2701 Forum Drive Grand Prairie, Texas 75051	(214) 641-0000
Paul G. Stringer ACT-306	Federal Aviation Administration Technical Center Atlantic City Airport Atlantic City, New Jersey 08405	(609) 641-8200
Richard J. Adams	Systems Control Technology, Inc. 2326 S. Congress Avenue-Suite 2A West Palm Beach, Florida 33406	(305) 968-4200

report. The relationships of these primary elements, the data sources used to define hazards the operator groups interviewed, and the schedule are shown in Figure A.3. As shown in the figure, the duration of Phase Two was twelve calendar months beginning in September 1983. Since a preliminary analysis of helicopter hazards had been performed in Phase One, and since very little data was collected from the operator groups in Phase One, the early emphasis in Phase Two was focused on operational data collection. As shown in Figure A.3, eight of the twelve groups were interviewed during the first six months of the period of performance. This early emphasis on operator perspective accomplished two objectives. First, it facilitated and expedited the development of an operator data base from notes taken during the interviews, questionnaire data collected, and perspectives gained during the discussions. Second, it provided a complimentary operator data base to be used as a sounding board in discussions with manufacturers, analysis of NTSB statistics, etc. The remainder of the interviews were conducted in months seven and nine of the period of performance as shown in Figure A.3. The operator perspectives obtained from these interviews were used to formulate an understanding of the current operational safety hazards and the pilot's perspective of those hazards. These perspectives are presented and discussed in Section 3.3.

The second task -- Helicopter Hazard Definition -- was started in earnest about mid January 1984 (month 5). This task involved reexamination of historical accident data from the NTSB for the years 1976-79, discussing both historical helicopter safety hazards and the pilot's perspective of hazards (from the interviews) with the manufacturers, and finally, a search for more recent 1980-1983 accident data. The latter was obtained from two sources. First, the FAA GADO in the Southwest Region attended the meeting with HSAC in Houston. As a result of his interest in the study and the SCT need for more current safety data, he arranged for and provided FAA helicopter accident/incident data for the 1980-83 time period. This data was supplemented by additional NTSB data contained in the Annual Review of Accident Data, U.S. General Aviation, 1983. As shown in Figure A.3, these four data sources were used to postulate the Helicopter Operational Hazards. These hazards are thoroughly discussed in Section 3.2. The following discussion provides more detail on the form and substance of the data collection/data analysis performed during Phase Two on a task by task basis.

#### A. Task E-4(a) -- Helicopter Hazards Definition

This task developed and finalized the definition of the hazards of helicopter operations through the analysis of historical rotorcraft accident/incident reports and statistics. In addition to the four primary data sources previously discussed and shown in Figure A.3, the following materials were extremely helpful in understanding the statistics and substantiating SCT's hypothesis regarding helicopter hazards:

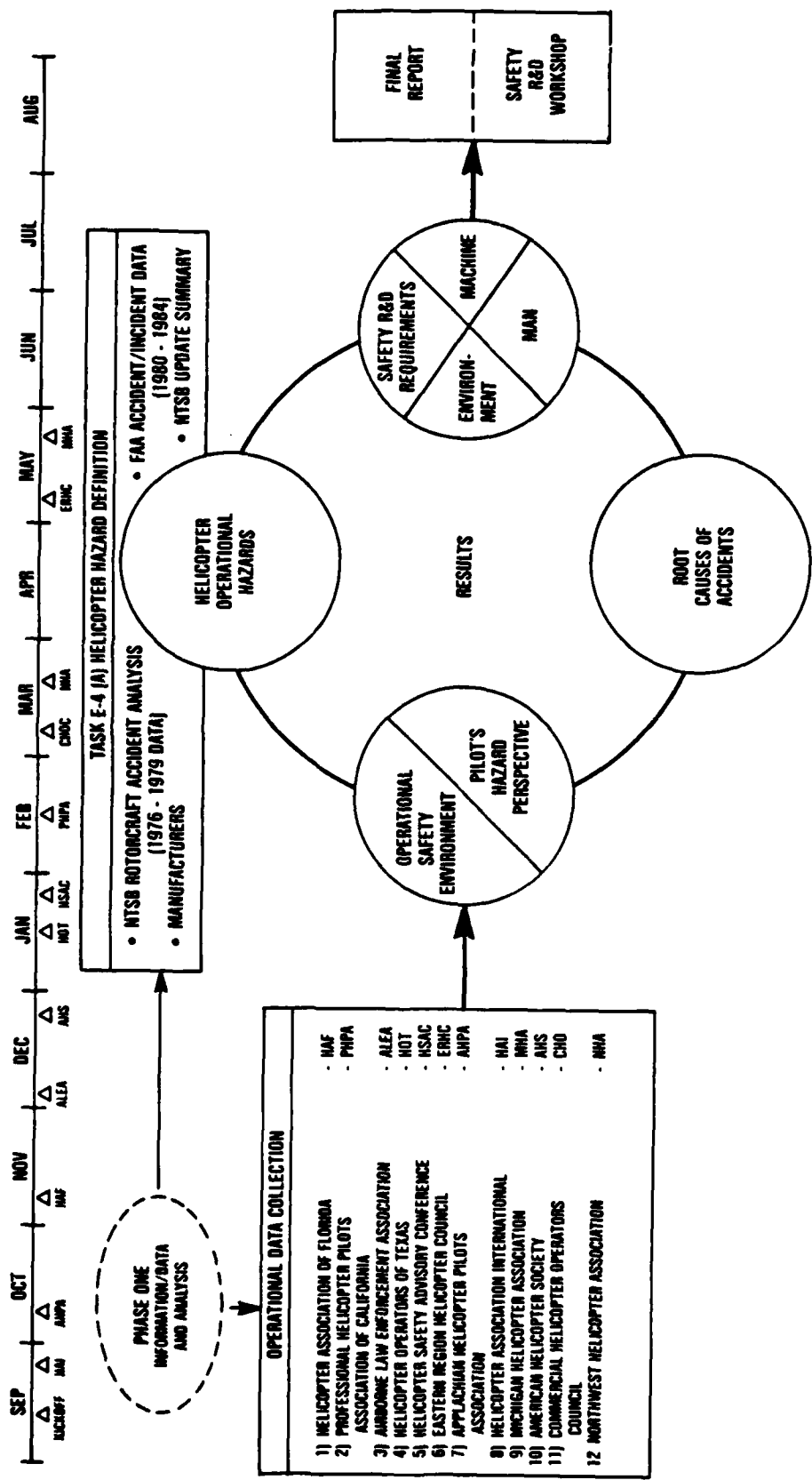

Figure A.3 Summary of Phase Two Tasks, Data Sources, Operator Groups and Results



- 1) Aviation Psychology by Dr. Stanley Roscoe. Iowa State University Press, Ames, Iowa, 1980.
- 2) General Aviation Safety Research Issues by Robert J. Ontiveros
- 3) Cause Factor: Human, A Treatise on Rotary Wing Human Factors by Olaf W. Skjenna, M.D.
- 4) Human Factors Aspects of Aircraft Accidents, AGARD Lecture - Series No. 125
- 5) The Influence of Total Flight Time, Recent Flight Time and Age on Pilot Accident Rates by Acumenics Research and Technology, Inc.
- 6) 1979, 1980, 1981, 1982, 1983 Army Reports on
  - a. Army Aircraft Accidents
  - b. Lessons Learned from U.S. Army Aviation Accident

These reports provided depth and guidance in performing the historical accident data analysis. Data from them was used by cross reference throughout the analysis. Specifically, the knowledge and experience available from these references was used to identify and substantiate the recognized safety hazards by mission type and to determine the primary environment, human factor or aircraft design solutions.

B. Task E-4(b) -- Operational Data Collection

Using the data and information from Phase One, Tasks E-1(a), (b), (c) and (d), operator interview/meetings were conducted as a primary data source for this task. The purpose of these interviews/meetings was to determine the current operational safety environment. The primary subjects for these interviews and their affiliation are listed in Table A.6.

The initial contacts and the interviews were conducted in the identical manner previously used in Phase One (see Tasks E-1(b) and E-1(c) methodology) telephone contacts, follow-up mailings, personal interview and data collection were successfully accomplished with all nine subjects. However, the consistency and quantity of data gathered did vary in the following manner:

Table A.6 Initial Phase Two Operational Interview Participants

NAME and TITLE	AFFILIATION
1. William D.C. Jones Director of Safety	Helicopter Association International
2. John F. Zugschwert Executive Director	American Helicopter Society
3. Lynn Clough Chairman	Helicopter Safety Advisory Council
4. Robert McDaniels President	Professional Helicopter Pilots Assoc.
5. Wanda Rogers President	Commercial Helicopter Operators Council
6. Al Scott President	Northwest Helicopter Association
7. Dee Young President	Appalachian Helicopter Pilots Assoc.
8. Roy Fox, Chief, Safety Analysis Department	Bell Helicopter Textron
9. Chris Fuller Chief of Systems Safety	Sikorsky Aircraft

1. Subjects 3, 4, 7 (HSAC, PHPA and AHPA) were successfully run through the entire set of planned interview, data collection follow-up, revised data process including participation of other group members.
2. Subjects 1, 2, 8, 9 were interviewed by telephone and met with personally in a one-on-one situation.
3. Subjects 5 and 6 were unavailable for personal interviews or meetings and therefore were only interviewed by telephone.

Since the operational perspective was such a critical element of this effort, it was decided to expand the data collection effort and thereby enhance both the quality and quantity of the interview data. Table A.7 lists the additional operator groups participating in the entire interview process described in Task E-1(c). Substantive data was obtained from each of these groups. The procedures used to collect this data were previously describes in the Task E-1(b) write-up. These procedures allowed the determination of the subjects perspective on helicopter safety hazards for various mission types, for VFR, SVFR and IFR operations and for various levels of pilot workload associated with flying different helicopter types. The net result of this interview process was a delineation and definition of the subjects perception of the root-causes of helicopter pilot error accidents. These causes are often masked and not obvious during post accident/incident investigations and frequently not sufficiently explained in statistical accident analyses. The root causes are presented and thoroughly analyzed in Section 3.3. A safety R&D workshop will be held to document these results and present them with the results of the literature review from Phase One. The workshop was required by Task E-4(d) and was performed in September 1985 at FAA headquarters.

Table A.7 Additional Phase Two Operational Interview Participants  
(Group Meetings)

---

1. Helicopter Association of Florida	-	HAF
2. Airborne Law Enforcement Association	-	ALEA
3. Helicopter Operators of Texas	-	HOT
4. Eastern Region Helicopter Council	-	ERHC
5. Michigan Helicopter Association	-	MHA

---

APPENDIX B

INTERVIEW INFORMATION PACKAGE

PROPOSED MEETING AGENDA

I.	INTRODUCTION AND DISUCSSION OF THE FAA'S HELICOPTER PROGRAM	10 min
II.	DISCUSSION OF YOUR EXPERIENCES WITH OPERATIONAL SAFETY HAZARDS AND ACCIDENT OR INCIDENT ANALYSIS TECHNIQUES	20 min
III.	REVIEW OF THE FAA'S HELICOPTER PROGRAM	10 min
IV.	PILOT SURVEY OF PROJECTED USE OF TCAS FOR HELICOPTER OPERATIONS	15 min
----- BREAK -----		
V.	PRESENTATION OF PHASE ONE OPERATOR SURVEY RESULTS	10 min
VI.	DISCUSSION OF ROOT CAUSES OF AIRCRAFT ACCIDENTS VS PILOT PERCEPTION VS STATISTICAL RESULTS	20 min
VII.	PILOT SURVEY OF:	
	A. Safety Hazards and Pilot Workloads	15 min
	B. Safety R&D Requirements	10 min
	C. Operations Survey	15 min
	TOTAL TIME	2 hrs 5 min

## GENERAL DISCUSSION TOPICS

1. OBSERVED DIFFERENCES BETWEEN SAFETY HAZARDS DEFINED BY:
  - a. NTSB, FAA, NASA
  - b. Manufacturers
  - c. Pilots
  
2. THE POSSIBLE NEED FOR A HELICOPTER TCAS:
  - a. Operational Environment
  - b. Engineering considerations
  - c. Human factors questions
  - d. Pilot useage
  
3. HELICOPTER ACCIDENT/INCIDENT ENVIRONMENT:
  - a. 'Pilot error', the high rate accident pilot, time of most accidents, etc.
  - b. Primary mission categories
  - c. Aircraft utilization by mission category
  - d. Mission duration by mission category
  - e. Crew size and ground support for each mission
  - f. Major operating problems
  - g. Major maintenance problems
  - h. Most difficult mission
  - i. Most frequent mission
  - j. Technical or operational needs not currently available
  - k. Future technical needs:
    - Aircraft
    - Aircraft systems
    - Support equipment
    - Special aircraft modifications or equipment

- o What is the title of the study?
  - Civil Helicopter Accident/Safety  
Hazard Definition  
(Contract No. DTFA01-80-C-10080, Task E-4)
- o Who is the Contract Monitor and where is he located?
  - Mr. Robert J. Ontiveros, ACT-340  
Department of Transportation  
Federal Aviation Administration Technical Center  
Atlantic City Airport  
Atlantic City, New Jersey 08045  
(609) 484-4463
- o What technical areas are included in the study?
  - 1. Pilot perception of the hazards of helicopter operations
  - 2. VFR & IFR pilot workload and duty cycle workload
  - 3. Operational defined safety R&D needs
  - 4. Operator defined safety R&D needs
- o How will the study be conducted?
  - 1. Analysis of historical helicopter accident statistics
  - 2. Pilot and operator interviews
  - 3. Pilot, operator and manufacturer data analysis
  - 4. Joint FAA//operator safety R&D workshop
- o What type of 'data' is needed?
  - o DATA ON CIVIL HELICOPTER OPERATIONAL USES OR MISSIONS
    - o Comprehensive set or list of helicopter uses
    - o Typical or average mission or flight profile
  - o OPERATOR CHARACTERISTICS
    - o Fleet composition
    - o Fleet sizes by aircraft type
    - o Hours flown
    - o Landing facilities used
    - o Locations of landing areas
    - o Number of operations (VFR, SVFR, IFR)
    - o Percent downtime and causes (unscheduled maintenance, weather, etc.
    - o Avionics capabilities and desires
    - o Others (?)

- o PILOT WORKLOAD PROFILE

- o Weekly/monthly hours flown
- o Duty cycle (days on vs days off)
- o Length of duty day (6-8-12 hours)
- o Flight hours per duty day
- o Spread of flight hours throughout duty day
- o Number of takeoffs and landings per day

- o PERCEPTION OF HAZARDS

- o Vehicle design
- o ATC interface
- o Human factors
- o Pilot Workload (flight deck design and operation)



**APPENDIX C**

**SAMPLE SURVEYS**



Research, Development and Technology Needed	Responsibility	
	MFG	FAA
<div style="text-align: right; border: 1px solid black; padding: 2px;">2. HUMAN FACTORS(Continued)</div> b. Future Aircraft:		
<div style="text-align: right; border: 1px solid black; padding: 2px;">3. SAFETY</div> a. Current Aircraft:  b. Future Aircraft:		
<div style="text-align: right; border: 1px solid black; padding: 2px;">4. AVIONICS AND FLIGHT CONTROLS</div> a. Current Aircraft:  b. Future Aircraft:		

Research, Development and Technology Needed		Responsibility	
		MFG	FAA
<div style="border: 1px solid black; display: inline-block; padding: 2px;">5. PROPULSION &amp; DRIVE TRAIN</div>			
a. Current Aircraft:			
b. Future Aircraft:			
<div style="border: 1px solid black; display: inline-block; padding: 2px;">6. AUXILIARY EQUIPMENT</div>			
a. Current Aircraft:			
b. Future Aircraft:			

Please make any comments or suggestions you may have concerning this program in the space provided below:

**PHASE ONE HELICOPTER OPERATIONS SURVEY**



HELICOPTER OPERATIONS SURVEY

1. Please identify, in the following table, the types of missions most frequently performed with your helicopter(s). Estimate the percentage of your operating time devoted to each mission and whether the use of the helicopter is mandatory (M) or desirable(D).

TYPE OF OPERATION	PERCENT UTILIZATION	M	D
Agriculture -----			
Air Carrier (Part 127) -----			
Air Taxi/Charter -----			
Ambulance -----			
Bank Paper Transportation -----			
Commuter Air Carrier (Scheduled) -----			
Construction -----			
Corporate (Part 91 Not for Hire) -----			
Executive Transport -----			
Exploration -----			
External Load -----			
Fire Control/Support -----			
Forestry, General -----			
Government Agency (Not for Hire) -----			
Herding (Cattle & Stock) -----			
Herding (Wildlife) -----			
Law Enforcement Agency -----			
Law Enforcement (For Hire) -----			
Logging -----			
Offshore -----			
Patrol (Power - Cable - Pipe) -----			
Photo -----			
Pollution Detection/Monitoring/Control -----			
Private (Personal) -----			
Search & Rescue -----			
Sightseeing -----			
Surveying -----			
Traffic Reporting -----			
Television (Electronic News Gathering & Other) -----			
Volcano Related Activities -----			

2. What is your most difficult mission? \_\_\_\_\_  
 \_\_\_\_\_

HELICOPTER OPERATIONS SURVEY

3. What aspect of any of the above missions is most demanding on your

a) aircraft? \_\_\_\_\_

\_\_\_\_\_

b) crew? \_\_\_\_\_

\_\_\_\_\_

4. Please indicate by type of operation the number and the severity of any accidents your agency has experienced.

TYPE OF OPERATION (e.g. Agriculture, Photo, Search & Research, etc.)	Accident Date			
	Total Accidents		Fatal Accidents	
	1980	1975-80	1980	1975-80
a.				
b.				
c.				
d.				
e.				
f.				

5. Please indicate the percent of flight time spent in the specified flight phase for both your primary and most difficult missions.

FLIGHT PHASE	Primary Mission*	Most Difficult Mission*
% Time at Cruise Speed		
% Time at Low (<50 kts) Speed?		
% Time at Max Speed?		
% Time at Hover?		

\*Note: These two missions may be the same in some cases.



HELICOPTER OPERATIONS SURVEY

6. Identify, in the following table, the flight phases during which accidents your agency has experienced have occurred.

FLIGHT PHASE	NUMBER OF ACCIDENTS	
	1980	1975-80
<u>Inflight:</u>		
Normal Cruise -----	_____	_____
Hovering -----	_____	_____
Starting Swath Run -----	_____	_____
Swath Run -----	_____	_____
Procedural Turnaround -----	_____	_____
<u>Takeoff:</u>		
Vertical -----	_____	_____
Initial Climb -----	_____	_____
<u>Landing:</u>		
Power-on Landing -----	_____	_____
Power-off Autorotative Landing -----	_____	_____
Final Approach (VFR) -----	_____	_____
Final Approach (IFR) -----	_____	_____
<u>Static:</u>		
Idling Rotors -----	_____	_____
<u>Other:</u>		
-----	_____	_____

7. How Many Aircraft Do You Currently Operate?

Helicopter \_\_\_\_\_ Fixed Wing \_\_\_\_\_

<u>Helicopter Type</u>	<u>No. of Aircraft</u>	<u>Average No. of Annual Flight Hours/Aircraft</u>
_____	_____	_____
_____	_____	_____
_____	_____	_____
_____	_____	_____
_____	_____	_____

HELICOPTER OPERATIONS SURVEY

8. How many operating bases do you employ? \_\_\_\_\_

9. Where are the majority of your operations based?

Airport  Private Heliport, separate from airport

Public Heliport, separate from airport

10. Indicate the frequency of accidents by helicopter type for your operation.

Helicopter Type	Total Accidents	Accident per helicopter	Accidents Per Year	
			1980	1975-80

11. What percent of your total maintenance is:

Scheduled \_\_\_\_\_ Unscheduled \_\_\_\_\_

12. What percent of your total maintenance is related to:

Engines \_\_\_\_\_ Rotors \_\_\_\_\_

Airframe \_\_\_\_\_ Avionics \_\_\_\_\_

Drive System \_\_\_\_\_ Other \_\_\_\_\_

13. To what do you attribute most unscheduled maintenance?

Hard Landings \_\_\_\_\_ Rotor Failure \_\_\_\_\_

Engine Failures \_\_\_\_\_ Vehicle Design \_\_\_\_\_

Airframe Failures \_\_\_\_\_ Operating Environment \_\_\_\_\_

Vibration \_\_\_\_\_ Other (Please Specify) \_\_\_\_\_

HELICOPTER OPERATIONS SURVEY

14. Which factor(s) are most significant in your aircraft availability?

Weather  Other (please specify)

Maintenance  \_\_\_\_\_

15. Please indicate by type of accident the number and severity of any accidents experienced by your agency.

TYPE OF ACCIDENT	Number of Accidents			
	1980		1975-80	
	Total	Fatal	Total	Fatal
Engine Failure or Malfunction				
Hard Landing				
Collision with Obstacles (wires, trees, poles)				
Roll Over				
Main Rotor Failure				
Tail Rotor Failure				
Air frame Failure In-flight				
Ground-water Loop-Swerve				
Other (please specify)				
a.				
b.				
c.				
d.				

16. What Percent of your normal operating time is lost due to bad weather?

17. How many of your aircraft are equipped for IFR flight?

HELICOPTER OPERATIONS SURVEY

18. Do you foresee the need for IFR capability in the future?

For what type of missions? \_\_\_\_\_  
\_\_\_\_\_  
\_\_\_\_\_

19. What areas of future helicopter research do you consider most important (1) and least important (6).

Vehicle Design \_\_\_\_\_

Human Factors \_\_\_\_\_

Safety \_\_\_\_\_

Avionics & Flight Controls \_\_\_\_\_

Propulsion & Drive Train \_\_\_\_\_

Auxiliary Equipment \_\_\_\_\_

20. What specific improvements are important to enhance and promote safety in your operation?

21. Has this questionnaire omitted any important items? Please tell us what they are?

PHASE TWO  
HAZARD SURVEY QUESTIONNAIRE

The answers to the following questions will be used to investigate the root causes of helicopter accidents, and to recommend various means to improve future accident rates. The Federal Aviation Administration Technical Center, Atlantic City, New Jersey, is sponsoring this study.

Your response to this survey is purely voluntary and will be kept strictly confidential. The answers from individual questionnaires will be aggregated to establish an industry profile of helicopter accident trends.

CENSUS

1.  
Name (optional) \_\_\_\_\_

Company (optional) \_\_\_\_\_

Address (optional) \_\_\_\_\_

Phone (optional) \_\_\_\_\_

Age \_\_\_\_\_

Type of operator (check appropriate boxes)

Part 91    Part 135    Part 127    VFR    IFR    Private

Corporate/Executive    Public Service    Other \_\_\_\_\_

2.  
Do your present duties include flying helicopters?

Yes    No

If yes,

Crew Position \_\_\_\_\_ Total Flight Time \_\_\_\_\_

Certificate Type \_\_\_\_\_ Hrs last year \_\_\_\_\_

Ratings Held \_\_\_\_\_ Hrs last 90 days \_\_\_\_\_

Class Medical \_\_\_\_\_

Training hrs last 90 days

Flight \_\_\_\_\_

Ground \_\_\_\_\_

3. What type helicopter do you primarily fly? \_\_\_\_\_  
\_\_\_\_\_ Hours in type. \_\_\_\_\_

Is your primary helicopter equipped and certified for IFR Operations.

Yes    No

HAZARD SURVEY QUESTIONNAIRE

The answers to the following questions will be used to investigate the root causes of helicopter accidents, and to recommend various means to improve future accident rates. The Federal Aviation Administration Technical Center, Atlantic City, New Jersey, is sponsoring this study.

Your response to this survey is purely voluntary and will be kept strictly confidential. The answers from individual questionnaires will be aggregated to establish an industry profile of helicopter accident trends.

CENSUS

1. Name (optional) \_\_\_\_\_

Company (optional) \_\_\_\_\_

Address (optional) \_\_\_\_\_

Phone (optional) \_\_\_\_\_

Age \_\_\_\_\_

Type of operator (check appropriate boxes)

Part 91    Part 135    Part 127    VFR    IFR    Private  
 Corporate/Executive    Public Service    Other \_\_\_\_\_

2. Do your present duties include flying helicopters?

Yes    No

If yes,

Crew Position \_\_\_\_\_

Certificate Type \_\_\_\_\_

Ratings Held \_\_\_\_\_

Class Medical \_\_\_\_\_

Total Flight Time \_\_\_\_\_

Hrs last year \_\_\_\_\_

Hrs last 90 days \_\_\_\_\_

Training hrs last 90 days

Flight \_\_\_\_\_

Ground \_\_\_\_\_

3. What type helicopter do you primarily fly? \_\_\_\_\_

\_\_\_\_\_ Hours in type. \_\_\_\_\_

Is your primary helicopter equipped and certified for IFR Operations.

Yes    No

**MISSION PROFILES**

1. What is your primary type helicopter mission? (Describe) \_\_\_\_\_

\_\_\_\_\_

\_\_\_\_\_

2. What is your most difficult type helicopter mission? (Why) \_\_\_\_\_

\_\_\_\_\_

\_\_\_\_\_

\_\_\_\_\_

3. What is the average duration (Flight Time) of your Primary Type of Flight Mission? \_\_\_\_\_

4. How many approaches to landing/hover do you perform on an average flight? \_\_\_\_\_

5. How many helicopters does your company currently operate? (If applicable)

Helicopter	Type	No. A/C	IFR/Cert.	Average # Annual Flight Hours
_____	_____	_____	_____	_____
_____	_____	_____	_____	_____
_____	_____	_____	_____	_____

6. Check the type facility you use as a primary base of operations.

<input type="checkbox"/> Airport	Public	<input type="checkbox"/> Yes	<input type="checkbox"/> No
<input type="checkbox"/> Heliport	Lighted	<input type="checkbox"/> Yes	<input type="checkbox"/> No
	Controlled	<input type="checkbox"/> Yes	<input type="checkbox"/> No

Other \_\_\_\_\_

DUTY CYCLE

1. Does your company have an established crew rest policy?  
 Yes     No
  
2. Your company's crew rest limitations are:  
 a. never exceeded  
 b. seldom exceeded  
 c. sometimes exceeded  
 d. often exceeded  
 e. always exceeded when mission requires
  
3. Indicate the percentage of annual flight hours which are flown during each of the following time periods:  

<input type="checkbox"/> 0001-0600	<input type="checkbox"/> 1200-1500
<input type="checkbox"/> 0600-0900	<input type="checkbox"/> 1500-1800
<input type="checkbox"/> 0900-1200	<input type="checkbox"/> 1800-2400

FLIGHT PLANNING

1. How many actual working hours are available between first notice of and the scheduled departure time for your primary mission?  
 a. less than 1/2 hour  
 b. 1/2 hr to 1 hr  
 c. 1 hr to 1-1/2 hr  
 d. 1-1/2 hr to 2 hrs  
 e. 2-3 hrs  
 f. more than 3 hours
  
2. You have 45 minutes to plan and preflight for a VFR flight of 1 hour in duration. Indicate your priority of work by placing numbers in ascending order before each task you elect to perform.  
 a. Check Weather  
 b. Plan Route of Flight  
 c. Prepare Weight and Balance  
 d. Check NOTAMS  
 e. Prepare/File Flight Plan  
 f. Performance Planning  
 g. Preflight Inspection of Aircraft  
 h. IGE Hover Checks  
 i. OGE Hover Checks  
 j. Ground Run-up Checks  
 k. Other (list) \_\_\_\_\_
  
3. You are forced to expedite your departure and have only 15 minutes to prepare for the same 1 hour VFR Flight. Check which ITEMS you would most likely OMIT as listed in the above question.  

<input type="checkbox"/> -a	<input type="checkbox"/> -c	<input type="checkbox"/> -e	<input type="checkbox"/> -g	<input type="checkbox"/> -i	<input type="checkbox"/> -k
<input type="checkbox"/> -b	<input type="checkbox"/> -d	<input type="checkbox"/> -f	<input type="checkbox"/> -h	<input type="checkbox"/> -j	<input type="checkbox"/> -l



### OPERATING PROCEDURES

1. At the landing areas you most frequently use, how is your approach direction most likely to be restricted. (Number by order of occurrence)  

<input type="checkbox"/> a. Published procedures	<input type="checkbox"/> d. Noise abatement instructions
<input type="checkbox"/> b. ATC instructions	<input type="checkbox"/> e. Not usually restricted
<input type="checkbox"/> c. Obstacles	<input type="checkbox"/> f. (Other) _____
  
2. Indicate the percentage of VFR approaches you perform for each of the following type:  

<input type="checkbox"/> a. very shallow ( 2)
<input type="checkbox"/> b. shallow (2-3)
<input type="checkbox"/> c. normal (4-6)
<input type="checkbox"/> d. steep (7-10)
<input type="checkbox"/> e. very steep ( 10)
  
3. During the last 200 feet of a VFR approach to landing, do your approach airspeeds tend to be:  

<input type="checkbox"/> a. slow
<input type="checkbox"/> b. moderately slow
<input type="checkbox"/> c. per operator's manual
<input type="checkbox"/> d. moderately fast
<input type="checkbox"/> e. fast

### TRAINING

1. During the previous 12 months how often have you performed the following practice emergency procedures (indicate the number of maneuvers performed, exclusive of annual or biennial flight review).  

<input type="checkbox"/> a. engine failure at hover (to the ground)
<input type="checkbox"/> b. engine failure at altitude (to the ground)
<input type="checkbox"/> c. engine failure - low altitude (to the ground)
<input type="checkbox"/> d. loss of tail rotor thrust
<input type="checkbox"/> e. emergency governor operations (manual control of throttle)
  
2. How often during the previous 12 months have you performed (other than annual or biennial instrument evaluations).  

<input type="checkbox"/> a. takeoffs in IMC
<input type="checkbox"/> b. instrument approaches in IMC
<input type="checkbox"/> c. enroute flight in IMC
<input type="checkbox"/> d. practice <u>hooded</u> instrument takeoffs
<input type="checkbox"/> e. practice <u>hooded</u> instrument approaches
<input type="checkbox"/> f. practice <u>hooded</u> enroute navigation
<input type="checkbox"/> g. practice instrument approaches-hooded-no attitude indicator
<input type="checkbox"/> h. practice instrument approaches-hooded-stuck card
<input type="checkbox"/> i. practice IFR lost communications procedures
<input type="checkbox"/> j. practice instrument approaches-hooded-no stability augmentation system

HAZARDS

1. Based on your experience and knowledge of previous helicopter accidents, indicate your estimate of the percentage of accidents primarily attributable to each of the following 4 categories: Equipment Malfunction, Weather, Pilot and Training. The sum of the percentages should not exceed 100%. Within each of the categories, specific causes are presented. Estimate the percentage of accidents within each category attributable to the described factor. Do not exceed 100%.

%	_____	Equipment Malfunction
	%	_____ Powerplant
	%	_____ Tail Rotor
	%	_____ Main Rotor
	%	_____ Flight Controls
	%	_____ Electrical Failure (during IMC)
	%	_____ Loss of Hydraulic Pressures
	%	_____ Airframe Failure
		100%
%	_____	Weather
	%	_____ Inadvertant IMC penetration
	%	_____ Icing
	%	_____ Limited Visibility, (blowing snow, dust, night, etc.)
	%	_____ Other (explain) _____
		100%
%	_____	Pilot
	_____	Loss of aircraft control
	%	_____ Failure to see and avoid aircraft
	%	_____ Failure to see and avoid obstacles
	%	_____ Fuel starvation
	%	_____ Loss of tail rotor thrust
	%	_____ Pilot fatigue
		100%
%	_____	Training
	%	_____ Practice emergency procedures
	%	_____ Mission training (sling loads, etc.)
	%	_____ Other (explain) _____
		100%
_____	%100	TOTAL

WEATHER

1. A. Indicate the total (approximate) number of missions you have flown this year. \_\_\_\_\_

B. Indicate the number of cancelled missions next to the listed item.

- 1) \_\_\_\_\_ weather
- 2) \_\_\_\_\_ equipment malfunction (inflight or preflight)
  - A) \_\_\_\_\_ airframe/powerplant/drive train
  - B) \_\_\_\_\_ electrical
  - C) \_\_\_\_\_ avionics
- 3) \_\_\_\_\_ lack of aircraft availability
- 4) \_\_\_\_\_ personnel
- 5) \_\_\_\_\_ other (specify \_\_\_\_\_)

2. For those instances when cancellation was forced by weather, indicate the percentage of times the following factors were primary in the go/no/go decision:

- \_\_\_\_\_ a. Aircraft not IFR equipped.
- \_\_\_\_\_ b. WX below takeoff minimums.
- \_\_\_\_\_ c. WX below landing minimums.
- \_\_\_\_\_ d. Insufficient fuel for IFR reserve and flight to alternate airport.
- \_\_\_\_\_ e. Navigation/communications equipment malfunction discovered during preflight or in flight.
- \_\_\_\_\_ f. Could not obtain ATC clearance.
- \_\_\_\_\_ g. Other (explain) \_\_\_\_\_

3. Rank order the following weather report elements according to their usefulness. Enter 1-3 for each item.

- 1) Critical item. Safe or legal approach not possible without it.
- 2) Item of interest, but not necessary for safe takeoffs or landings.
- 3) Not useful.

- |                         |                             |
|-------------------------|-----------------------------|
| _____ surface winds     | _____ winds aloft           |
| _____ gust spread       | _____ 30 minute forecast    |
| _____ ceiling           | _____ NOTAMS                |
| _____ visibility        | _____ SIGMETS/AIRMETS/etc   |
| _____ temperature       | _____ runway temp.          |
| _____ dewpoint          | _____ runway conditions     |
| _____ pressure altitude | _____ other (specify _____) |
| _____ density altitude  | _____ other (specify _____) |

4. The automated weather observation system may have the capability of being accessed through several means. Rank order the following (1-most likely, 8 least likely) by the likelihood that you would use the service to receive weather reports.

- 1. VHF transmitter
- 2. Discrete frequency
- 3. NDB (voice channel)
- 4. VOR (voice channel)
- 5. Dialup telephone
- 6. High speed computer modem
- 7. MLS data link
- 8. Mode "s" data link

5. Automated weather observation facilities have been in use on a test basis in various locations throughout the U.S. since October 1983. Have you used any of those services?

How many times?

6. Compared to standard FSS observations did you find the automated report: (Check appropriate blocks)

easier to obtain  
 the same check 1  
 harder to obtain

more accurate  
 the same check 1  
 less accurate

sufficient to complete your mission  
 insufficient other data required check 1  
specify ( \_\_\_\_\_ )