

MICROCOPY RESOLUTION TEST CHART
NATIONAL BUREAU OF STANDARDS-1963-A

12



US Army Corps of Engineers

ENVIRONMENTAL IMPACT RESEARCH PROGRAM

TECHNICAL REPORT EL-86-21

OSPREY NEST PLATFORMS

Section 5.1.6, US ARMY CORPS OF ENGINEERS WILDLIFE RESOURCES MANAGEMENT MANUAL

by

Chester O. Martin, Wilma A. Mitchell

Environmental Laboratory

DEPARTMENT OF THE ARMY

Waterways Experiment Station, Corps of Engineers PO Box 631, Vicksburg, Mississippi 39180-0631

and

Donald A. Hammer

Tennessee Valley Authority Norris, Tennessee 37828



DTIC ELECTE SEP 3 1986

B

July 1986 Final Report

Approved For Public Release Distribution Unlimited

Prepared for DEPARTMENT OF THE ARMY US Army Corps of Engineers Washington, DC 20314-1000

Under EIRP Work Unit 31631

Monitored by Environmental Laboratory US Army Engineer Waterways Experiment Station PO Box 631, Vicksburg, Mississippi 39180-0631

86 9 3 105

DTIC FILE COPY

AD-A171 751



Destroy this report when no longer needed. Do not return
it to the originator.

The findings in this report are not to be construed as an official
Department of the Army position unless so designated
by other authorized documents.

The contents of this report are not to be used for
advertising, publication, or promotional purposes.
Citation of trade names does not constitute an
official endorsement or approval of the use of
such commercial products.

Unclassified

SECURITY CLASSIFICATION OF THIS PAGE

AD A171 751

REPORT DOCUMENTATION PAGE				Form Approved OMB No 0704 0188 Exp Date Jun 30 1986	
1a REPORT SECURITY CLASSIFICATION Unclassified		1b RESTRICTIVE MARKINGS			
2a SECURITY CLASSIFICATION AUTHORITY		3 DISTRIBUTION / AVAILABILITY OF REPORT			
2b DECLASSIFICATION / DOWNGRADING SCHEDULE		Approved for public release; distribution unlimited			
4 PERFORMING ORGANIZATION REPORT NUMBER(S)		5 MONITORING ORGANIZATION REPORT NUMBER(S)			
6a NAME OF PERFORMING ORGANIZATION See reverse		6b OFFICE SYMBOL (if applicable)		7a NAME OF MONITORING ORGANIZATION USAEWES Environmental Laboratory	
6c ADDRESS (City, State, and ZIP Code) PO Box 631, Vicksburg, MS 39180-0631; Norris, TN 37828		7b ADDRESS (City, State, and ZIP Code) PO Box 631 Vicksburg, MS 39180-0631			
8a NAME OF FUNDING / SPONSORING ORGANIZATION US Army Corps of Engineers		8b OFFICE SYMBOL (if applicable)		9 PROCUREMENT INSTRUMENT IDENTIFICATION NUMBER	
8c ADDRESS (City, State, and ZIP Code) Washington, DC 20314-1000		10 SOURCE OF FUNDING NUMBERS			
		PROGRAM ELEMENT NO	PROJECT NO	TASK NO	WORK UNIT ACCESSION NO EIRP 31631
11 TITLE (include Security Classification) Osprey Nest Platforms: Section 5.1.6, US Army Corps of Engineers Wildlife Resources Management Manual					
12 PERSONAL AUTHOR(S) Martin, Chester O., Mitchell, Wilma A., and Hammer, Donald A.					
13a TYPE OF REPORT Final report		13b TIME COVERED FROM _____ TO _____		14 DATE OF REPORT (Year, Month, Day) July 1986	
				15 PAGE COUNT 34	
16 SUPPLEMENTARY NOTATION Available from National Technical Information Service, 5285 Port Royal Road, Springfield, VA 22161.					
17 COSATI CODES			18 SUBJECT TERMS (Continue on reverse if necessary and identify by block number)		
FIELD	GROUP	SUB-GROUP	Osprey <i>Pandion haliaetus</i>		
			Osprey management Raptor management		
			Osprey nest platforms (Continued)		
19 ABSTRACT (Continue on reverse if necessary and identify by block number)					
<p>- A management techniques report on osprey nest platforms is provided as Section 5.1.6 of the US Army Corps of Engineers Wildlife Resources Management Manual. The report was prepared as a guide to assist Corps biologists and resource managers in developing nesting habitat for ospreys (<i>Pandion haliaetus</i>) on project lands. Topics covered for nest structures include nest site selection, management objectives, design, construction, installation, location, maintenance, personnel and costs, cautions and limitations, platform success, and evaluation.</p> <p>Breeding populations of ospreys are widespread in coastal areas and some inland regions of the United States, and nesting activities at reservoirs have increased substantially in recent years. Because a lack of suitable nest sites may inhibit colonization of otherwise suitable habitat or limit population growth, properly constructed and located platforms can</p> <p style="text-align: right;">(Continued)</p>					
20 DISTRIBUTION AVAILABILITY OF ABSTRACT <input checked="" type="checkbox"/> UNCLASSIFIED UNLIMITED <input type="checkbox"/> SAME AS RPT <input type="checkbox"/> DTIC USERS			21 ABSTRACT SECURITY CLASSIFICATION Unclassified		
22a NAME OF RESPONSIBLE INDIVIDUAL			22b TELEPHONE (include Area Code)		22c OFFICE SYMBOL

6a. PERFORMING ORGANIZATION (Continued).

USAEWES, Environmental Laboratory;
Tennessee Valley Authority

18. SUBJECT TERMS (Continued).

Artificial nesting structures	Wildlife management
Osprey nesting habitat	Management practices and techniques

19. ABSTRACT (Continued).

be a highly effective tool for osprey management. The development of artificial nest structures for ospreys is presented in this report; guidelines for construction, installation, and placement are emphasized. Detailed design specifications are provided for frame platforms, solid base platforms, ring platforms, tripod structures, and platform supports. Management goals and procedures for evaluating the success of osprey platforms are discussed.



Accession For	
NTIS	✓
DTIC	
General	
JPL	
By	
Distribution	
Availability	
Dist	
A-1	

PREFACE

This work was sponsored by the Office, Chief of Engineers (OCE), US Army, as part of the Environmental Impact Research Program (EIRP), Work Unit 31631, entitled Management of Corps Lands for Wildlife Resource Improvement. The Technical Monitors for the study were Dr. John Bushman and Mr. Earl Eiker, OCE, and Mr. Dave Mathis, Water Resources Support Center.

This report was prepared by Mr. Chester O. Martin, Wetlands and Terrestrial Habitat Group (WTHG), Environmental Laboratory (EL), US Army Engineer Waterways Experiment Station (WES); Dr. Wilma A. Mitchell, WTHG, EL, WES; and Dr. Donald A. Hammer, Division of Land and Economic Resources, Tennessee Valley Authority, Norris, Tenn. Mr. Martin, Team Leader, Wildlife Resources Team, WTHG, was principal investigator for the work unit. The authors express their appreciation to the following individuals for providing guidelines and specification details for construction, installation, and placement of osprey platforms: Mr. Robert A. Adair, US Bureau of Reclamation, Boise, Idaho; Mr. Mark A. Westall, President, International Osprey Foundation, Sanibel, Fla.; Mr. Sergej Postupalsky, Madison, Wis.; and Mr. Thomas U. Fraser, Sr., Conservation for Survival, Grosse Pointe Shores, Mich. Others who contributed information on various aspects of osprey management included Mr. Glen A. Carowan, Chassahowitzka National Wildlife Refuge Complex, US Fish and Wildlife Service, Homasassa, Fla.; Mr. Peter W. Havens, Naval Submarine Base, Kings Bay, Ga.; Mr. Lawrence J. Van Daele, Alaska Department of Fish and Game, Anchorage, Alaska; Dr. Alexander Sprunt, Research Director, The National Audubon Society, Taverner, Fla.; and Dr. Charles J. Henny, Director, Pacific Northwest Field Station, Patuxent Wildlife Research Center, US Fish and Wildlife Service, Corvallis, Oreg. Special thanks go to Mr. Larry E. Marcy, Texas A&M University, for developing information on design and construction details. Mr. Robert S. Wardwell, Armed Forces Pest Management Board, Forest Glen Section, WRAMC, Washington, D.C., provided precautionary information on the use of wood preservatives.

The report was prepared under the general supervision of Dr. Hanley K. Smith, Chief, WTHG, EL; Dr. Conrad J. Kirby, Chief, Environmental Resources Division, EL; and Dr. John Harrison, Chief, EL. Dr. Roger T. Saucier, WES, was Program Manager, EIRP. The report was edited by Ms. Jessica S. Ruff of the WES Publications and Graphic Arts Division (PGAD). Drawings were

prepared by Mr. John R. Harris, Scientific Illustrations Section, PGAD, under the supervision of Mr. Aubrey W. Stephens, Jr.

At the time of publication, COL Allen F. Grum, USA, was Director of WES, and Dr. Robert W. Whalin was Technical Director.

This report should be cited as follows:

Martin, Chester O., Mitchell, Wilma A., and Hammer, Donald A. 1986. "Osprey Nest Platforms: Section 5.1.6, US Army Corps of Engineers Wildlife Resources Management Manual," Technical Report EL-86-21, US Army Engineer Waterways Experiment Station, Vicksburg, Miss.

NOTE TO READER

This report is designated as Section 5.1.6 in Chapter 5 -- MANAGEMENT PRACTICES AND TECHNIQUES, Part 5.1 -- NESTING AND ROOSTING STRUCTURES, of the US ARMY CORPS OF ENGINEERS WILDLIFE RESOURCES MANAGEMENT MANUAL. Each section of the manual is published as a separate Technical Report but is designed for use as a unit of the manual. For best retrieval, this report should be filed according to section number within Chapter 5.

OSPREY NEST PLATFORMS

Section 5.1.6, US ARMY CORPS OF ENGINEERS
WILDLIFE RESOURCES MANAGEMENT MANUAL

NEST SITE SELECTION	3	Power Poles	20
MANAGEMENT OBJECTIVES	4	LOCATION	21
DESIGN, CONSTRUCTION, AND INSTALLATION	6	MAINTENANCE	22
Supports	6	PERSONNEL AND COSTS	22
Frame Platform	8	CAUTIONS AND LIMITATIONS	23
Solid Base Platform	10	PLATFORM SUCCESS	23
Ring Platform	15	EVALUATION	24
Sanibel Tripod	17	LITERATURE CITED	26
		APPENDIX A: NEST SURVEY FORM	31

Breeding populations of ospreys (*Pandion haliaetus*) are widespread in coastal areas and some inland regions of the United States, and nesting activity is invariably associated with aquatic habitats such as rivers, lakes, estuaries, seacoasts, and reservoirs. Although misuse of pesticides (Henny and Wight 1969), shooting (Wiemeyer et al. 1980), nest site disturbance (Reese 1970), and extensive timber clearing have severely impacted local and regional populations, the creation of reservoirs has significantly increased the available fishery resource and, in many areas, the nesting substrate. Continued reduction of environmental pollutants, coupled with increased public awareness of raptors, provides opportunities for manipulation of the remaining critical requirements for successful osprey populations--food supply and nesting habitat. The development of artificial nest structures as a management tool for breeding ospreys is discussed in this report; guidelines for construction, installation, and placement are emphasized.

NEST SITE SELECTION

An understanding of nesting habitat requirements is essential to the proper management of ospreys. Open-topped live or dead trees are preferred

natural nest sites throughout the range of the species (Zarn 1974). However, ospreys commonly nest on the ground in island situations (Bent 1937), in low trees 6 to 8 ft over water, on cliffs (Henny and Anderson 1979), and on man-made structures including docks, duck blinds, chimneys, towers, power poles, fishnet stakes, crossed wires, buoys, channel markers, and lighthouses (Bent 1937, Schmid 1966, French and Koplín 1977, Henny et al. 1977, Kennedy 1977, Ogden 1977, Postupalsky 1977). A typical nest is 4 to 6.5 ft in diameter and 1 to 2 ft deep; sticks up to approximately 7 ft long are used as nesting material, and the inner portion is lined with grass, bark, and mud (Kahl 1972, Van Daele 1980).

Ospreys select a nest site that provides maximum visibility of the surrounding terrain. A duck blind or stake only 4 ft above water may suffice in some areas, whereas the highest cypress or pine may be required in a dense forest. The average nest height is 12 ft in the Florida Everglades (Ogden 1977) but exceeds 100 ft in some forests of northwestern California (French and Koplín 1977). A resting perch, used primarily by the male when not fishing or nest tending, is usually located nearby; this site has similar visibility requirements as the nest and is often referred to as a pilot tree (Kahl 1972, Van Daele 1980).

Nests are frequently located over water or at the water's edge, but some have been reported as far as 3 to 4 miles from water (Roberts 1970, Szaro 1972, Dunstan 1973, Gale and Forbis 1974, Van Daele et al. 1980, Airola and Shubert 1981). Nest sites are usually near favored fishing areas (Reese 1970, Parnell and Walton 1977) but are occasionally concentrated on isolated lakes as far as 6 miles from suitable fishing (Jamieson et al. 1982).

MANAGEMENT OBJECTIVES

Since a lack of suitable nest sites may inhibit colonization of otherwise suitable habitat or limit population growth, properly constructed and appropriately located platforms can be a highly effective tool for osprey management (Fig. 1). Benefits of artificial platforms include: (1) provision of nests in areas that lack sufficient natural nest sites, (2) replacement of insecure natural nests, (3) relocation of nests away from excessive disturbance, and (4) substitution of nests located on hazardous or conflicting man-made structures (Reese 1977; Postupalsky 1978; Eckstein et al. 1979; Ansell and Smith 1980; Van Daele and Van Daele 1982; Beddow, in press).



Figure 1. Ospreys using an artificial nest platform at Cascade Reservoir, Long Valley, Idaho (photo courtesy of Bob Adair, U.S. Bureau of Reclamation)

The provision of platforms allows breeding ospreys to remain in or occupy suitable habitat despite the absence or deterioration of natural nest sites, especially in man-made impoundments and open-water areas (Postupalsky and Stackpole 1974, Postupalsky 1978). The addition of platforms can eliminate nest sites as a limiting factor and permit population increases commensurate with the available prey base (Rhodes 1972). Platforms can also aid in the reestablishment of an osprey population (Hammer 1981) and can be selectively placed to attract new breeding pairs into suitable but unoccupied habitat. Postupalsky (1978) found that ospreys fledged from platforms in Michigan colonized reservoirs that were previously unoccupied in the area. Henny (1983) cautioned that a strong fidelity of ospreys to ancestral breeding areas may inhibit natural dispersal into new habitat. However, Sergej Postupalsky (Madison, Wisconsin, pers. commun., 1984) attributed this fidelity more to established pairs (adult breeders) than to young birds and has records of ospreys nesting 120 and 250 miles from their natal areas.

Replacing insecure natural nests with stable platforms can greatly reduce nest loss resulting from wind damage and flooding. In a Chesapeake Bay study, 19.5% of active natural nests were blown down, and 17% were destroyed by tidal flooding (Reese 1970). Kahl and Garber (1971) attributed 60% of natural nest losses to wind damage at Eagle Lake, California, and aerial surveys in Wisconsin indicated that 5% to 10% of nests on natural sites blow down each year (Eckstein et al. 1979). Thus, well-constructed platforms can reduce nest loss and improve the productivity of a breeding population.

Installation of platforms has been successful in relocating ospreys from nest sites near houses, roads, heavily used shorelines, and boat channels (Eckstein et al. 1979; Beddow, in press). Although some pairs that nest close to man become habituated and can tolerate human activity, disturbances during incubation and early nesting stages can substantially reduce nest success. Platforms have also enticed nesting pairs away from powerlines, light towers, microwave towers, and meteorological stations.

DESIGN, CONSTRUCTION, AND INSTALLATION

A variety of platform designs have been used for osprey nests, most of which consist of a frame or solid base that can be mounted atop trees or artificial supports. Because of the similarity of designs, only 3 types of platforms, 3 methods of platform support, and a combination technique are described below. These structures are durable, easy to construct, and cost effective. Basic information on supports is presented under the first topic heading below. Tripod supports are usually designed for specific types of structures; therefore, their specifications are included under the appropriate platform description. Modified platforms and discouragement devices for electrical distribution lines are discussed in the section entitled Power Poles.

Supports

The platform support may be a snag, live topped tree, pole, or tripod structure. A single support is generally sufficient, but tripods are more effective on lakes subject to heavy ice movement and in marshes where the substrate is too soft to support a pole. The best time to install most platforms is late summer or fall when water levels are usually lowest. For pole supports the sites should be accessible to equipment, and the ground should be

dry enough to allow digging. Tripods used in areas of heavy ice should be installed in late winter or early spring immediately after the ice has melted.

When installed, the support should hold the platform at least 12 to 15 ft above the ground or surface of the water. Natural supports should be selected to comply with these heights at high water levels, and poles should be a minimum of 25 ft to allow 6-ft placement in the ground. Poles and natural supports should have at least a 5-in. top diameter. Trees and snags should be topped to a level where the wood is solid, and holes should be sealed with tar or caulking. If predation is a problem at the site, a 4-ft-long strip of sheet metal can be attached around the middle section of the pole or tree; conical predator guards can be used on tripod supports.

The type of support commonly determines the longevity of the platform. Snags may deteriorate within a few seasons, but live topped trees have considerably greater longevity. Artificial structures can be expected to last 15 to 20 years. All poles should be pressure treated, a process by which wood is impregnated with a preservative to prevent deterioration. Creosote-treated wood has been used, but freshly treated poles are difficult to work with; weathering the poles for 2 to 3 years or using discarded utility poles will facilitate handling. Copper-chromated arsenate (CCA) has been effectively used to treat milled lumber and support poles in several areas (Glen A. Carowan, Chassahowitzka National Wildlife Refuge, pers. commun., 1984); the compound was reported to leave wood safe and clean for handling and to provide protection against rot and decay, termites, and marine borers. However, biologists with the Tennessee Valley Authority (TVA) reported problems with leaching of the compound that resulted in waterfowl mortality in flight pens constructed of CCA-treated lumber. Extreme caution should be employed when working with pressure-treated lumber because some of the commonly used wood preservatives have recently been designated as restricted-use pesticides by the Environmental Protection Agency (EPA). These include pentachlorophenol (penta), creosote, and the inorganic arsenicals CCA, ammonia-chromated arsenate (ACA), or ammonia-chromated zinc arsenate (ACZA). When handling pressure-treated lumber or applying wood preservatives, EPA labels and consumer information sheets must be strictly followed (Robert S. Wardwell, Armed Forces Pest Management Board, Washington, D.C., pers. commun. May 1986).

Frame Platform

The platform described here is a 3- × 3-ft wooden frame covered with welded wire fabric. Specifications are provided in Figure 2, and materials required for construction are listed in Table 1. The design follows that used by the Bureau of Reclamation (Bob Adair, U.S. Bureau of Reclamation, Boise, Idaho, pers. commun., 1983). Lumber used for the platform should be durable softwood such as redwood, cedar, or cypress. If platforms are located in marine or extremely humid environments, weathered, pressure-treated lumber should be used.

The outer frame of the platform consists of three 2- × 4-in. × 3-ft boards and one 2- × 4-in. × 6-ft board joined to form a 3-ft-square frame with one 3-ft extension; the extension is designed to serve as a perch. The center supports are comprised of four 2- × 6- × 32-in. boards that are notched (mortised) and joined to form 4 cross-lap joints; the inside edges of the notches should be spaced 5 in. apart. The bottom of each center support should be cut at an angle (beveled) approximately 6 in. from the end to match up with the 2- × 4-in. outside support (Fig. 2, Section). All joints should be glued and

Table 1. Materials needed to construct a frame platform for ospreys

<u>Item</u>	<u>Quantity</u>
<u>FRAME PLATFORM</u>	
Lumber	
2 × 4 in. × 3 ft	3
2 × 4 in. × 6 ft	1
2 × 6 in. × 3 ft	4
Hardware	
Nails, common 16d galvanized	1/2 lb
Nails, common 6d galvanized	1/4 lb
Galvanized metal strap, 3/8 × 14 in.	2
Bolts, 3/8 × 10 in.	4
Galvanized welded wire fabric, 1- × 2-in. mesh	3 sq ft
Heavy-duty wire staples, 7/8 in.	1/4 lb
Miscellaneous	
Hardwood dowels, 5/8 × 7 in.	12
Wood glue	1 container (16 oz)
<u>SUPPORT POLE</u>	
Pressure-treated pole, 25-ft minimum height, with 5-in. top diameter	1

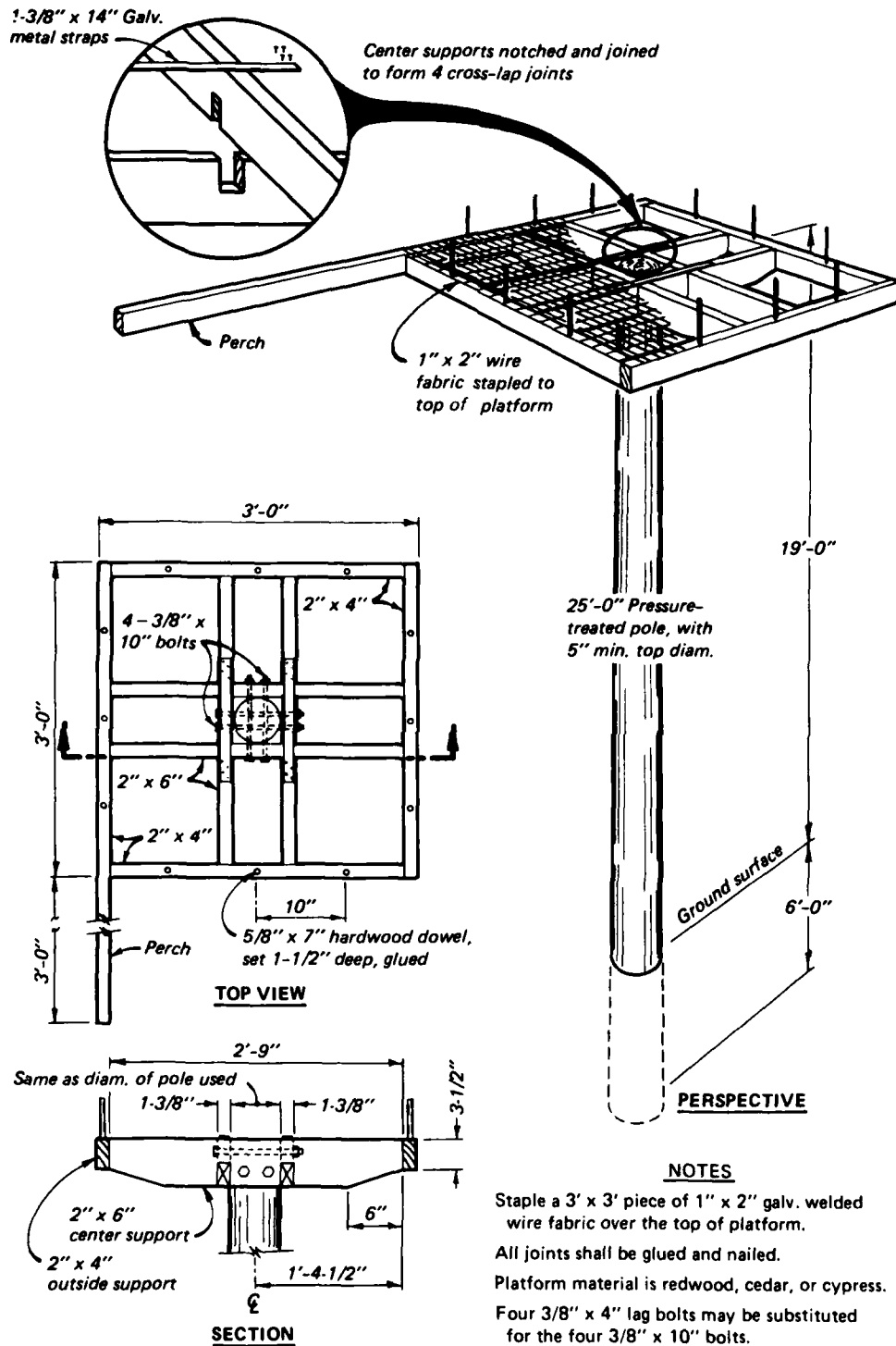

Figure 2. Design specifications for a frame nesting platform for ospreys (after guidelines provided by Bob Adair, U.S. Bureau of Reclamation)

nailed. To provide additional support, galvanized metal straps are nailed across the cross-lap joints. After the framework has been constructed, a 3- x 3-ft piece of 1- x 2-in.-mesh galvanized welded wire fabric is stapled across the top of the platform. To help secure nest materials to the platform, twelve 5/8- x 7-in. hardwood dowels are set 2 in. deep and 10 in. apart into the upper edge of the 2- x 4-in. supports.

Frame platforms are usually mounted on a single pole support. If the frame is to be placed atop a snag or live topped tree, dimensions of the center supports will probably need altering prior to construction. To mount the frame on a pole, the sides around the top of the pole must be trimmed so that the center supports fit flush against the pole. Details for construction of center supports for the frame are shown in Figure 2. Bolt positions should be marked on both the pole and frame, and the pole should be preaugered if lag bolts are used. The assembly is completed by bolting the platform onto the pole.

The completed platform assembly can be trucked to the installation site and set into a hole with a backhoe. Holes for artificial supports can be excavated with a power auger and should be a minimum of 6 ft deep. The pole must be set into a dry hole because one set into a wet hole may eventually lean, thus creating a safety hazard and possibly eliminating an accepted nest site (Bob Adair, U.S. Bureau of Reclamation, pers. commun., 1983). Poles must not be set in concrete because pole shrinkage with subsequent accumulation of water may result in wood deterioration. After installing the pole, the soil should be tamped very tightly in layers up to the surface of the ground, and the pole should be plumbed as tamping proceeds to ensure that it will stand in a vertical position. Adding a base of sticks to the platform after installation may attract ospreys to the structure and facilitate nest construction.

Solid Base Platform

Platform design. The solid base platform described here is essentially a 3-ft square cut from 3/4-in. AC exterior plywood. The corners are sawed off to make an octagon in the recommended design (Fig. 3, after guidelines provided by Thomas U. Fraser, Sr., Conservation for Survival, Grosse Point Shores, Michigan, 1984). Materials are listed in Table 2. After cutting the base, a series of 3/4-in. holes are drilled through the base to allow for water drainage. Twelve nest material retainers are installed around the edge

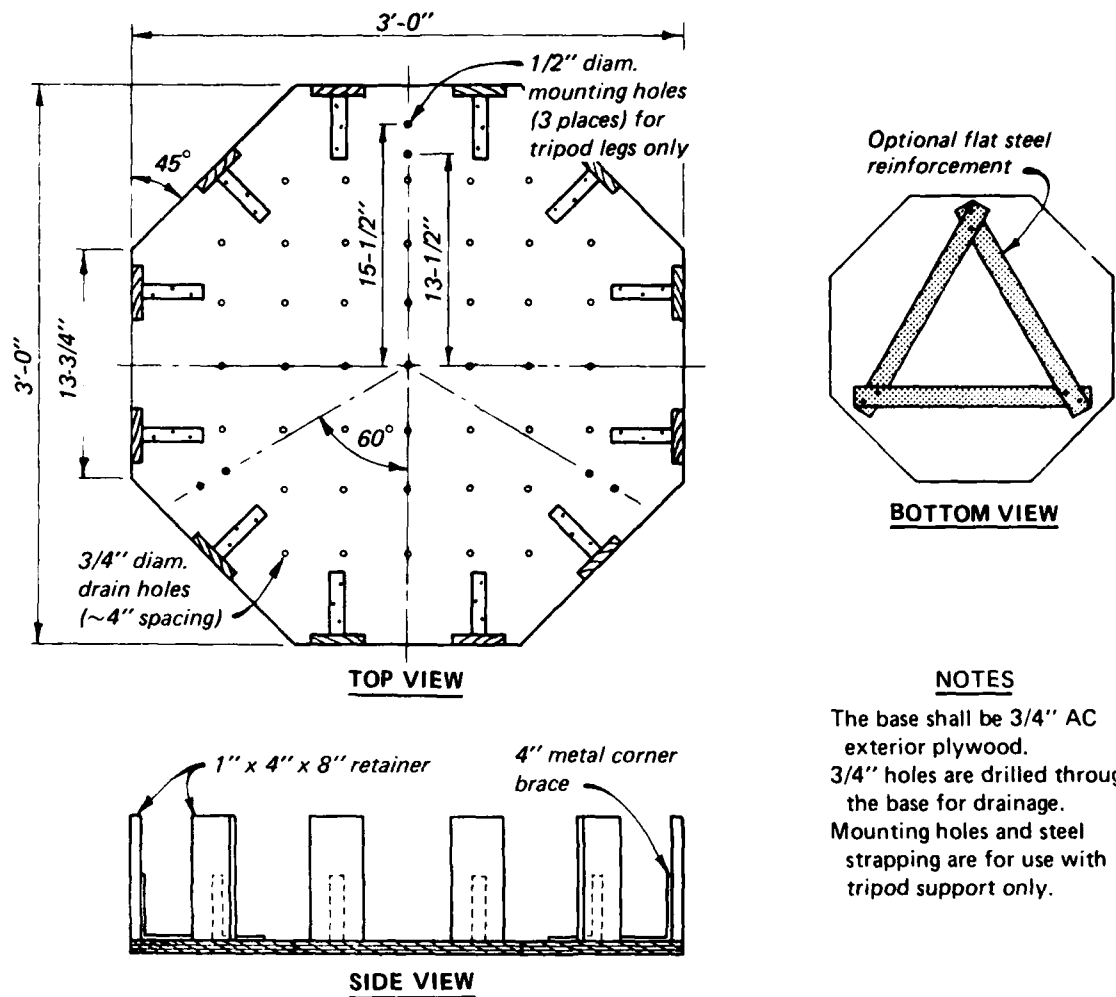

Figure 3. Design specifications for a solid base nesting platform for ospreys (after guidelines provided by Thomas U. Fraser, Sr., Conservation for Survival)

of the base. Each is constructed of a 1- x 4- x 8-in. block set on end and attached to the platform with a 4-in. corner brace and wood screws; two 2-in. wood screws are driven into the retainer from the bottom of the platform, and six 3/4-in. wood screws are used to attach the predrilled brace to the platform and retainer.

Solid base platforms may be mounted on either a single support or a tripod. If a tripod is used, 3 pairs of mounting holes should be drilled in the platform at points equidistant from each other to connect the legs; the holes should be 13-1/2 in. and 15-1/2 in. from the center of the platform (see Fig. 3 for spacing details). Flat steel reinforcements (Fig. 3, Bottom View)

Table 2. Materials needed to construct a solid base platform and supports

Item	Quantity
PLATFORM	
3/4-in. AC exterior grade plywood, 3 × 3 ft	1
Blocks, 1 × 4 × 8 in. (nest material retainers)	12
Metal corner braces, 4-in.	12
Wood screws, 2-in. (for attaching retainer to platform)	24
Wood screws, 3/4-in. (for attaching metal corner braces to platform and retainer)	72
Steel strapping, 1/4 × 3/4 × 27 in. (optional reinforcements for bottom of platform--for use with tripod support only)	3
SUPPORT A	
Lumber, 2 × 4 in. × 3 ft (horizontal platform supports)	2
Conduit, 1/2- or 3/4-in. diam, 3 to 4 ft long (struts)	2
Nails, 16d (for nailing platform supports to pole)	4
Nails, 8d to 10d (for nailing platform to supports)	12
Lag bolt or wood screw, 2-in. (for attaching strut to pole)	4
Lag bolt or wood screw, 3/4-in. (for attaching strut to support)	4
SUPPORT B	
Conduit, 1/2- or 3/4-in. diam, 3 to 4 ft long (struts)	3
Lag bolt or wood screw, 2-in. (for attaching struts to pole)	6
Lag bolt or wood screw, 3/4-in. (for attaching struts to platform)	6
Nails, 20d (for attaching platform to top of pole)	2-3
TRIPOD SUPPORT	
Galvanized steel pipe, 1-1/2-in. I.D. × 21 ft	3
Pipe coupling for 1-1/2-in. I.D. steel pipe	6
Steel plate, 3 × 3-1/4 in.	6
Hex-head bolts, 2-1/2- × 1/2-in. diam	3
Hexnuts, 1/2-in. diam	3
Washers and lockwashers, 1/2-in. diam	3
Predator guard, sheet metal cone	3

may be attached to the bottom of a tripod platform for added strength; these are described in the section entitled Tripod Support.

Pole supports. Two designs are suggested for attaching the solid base platform to a pole or tree. In the first method (Fig. 4, Support A), two opposite sides of the pole are notched at the top so that two 2- × 4-in. × 3-ft horizontal supports can be nailed to the flattened surfaces. Two struts made from 1/2- or 3/4-in. conduit with the ends hammered flat and predrilled are screwed, nailed, or lag-bolted to the platform support and the pole or

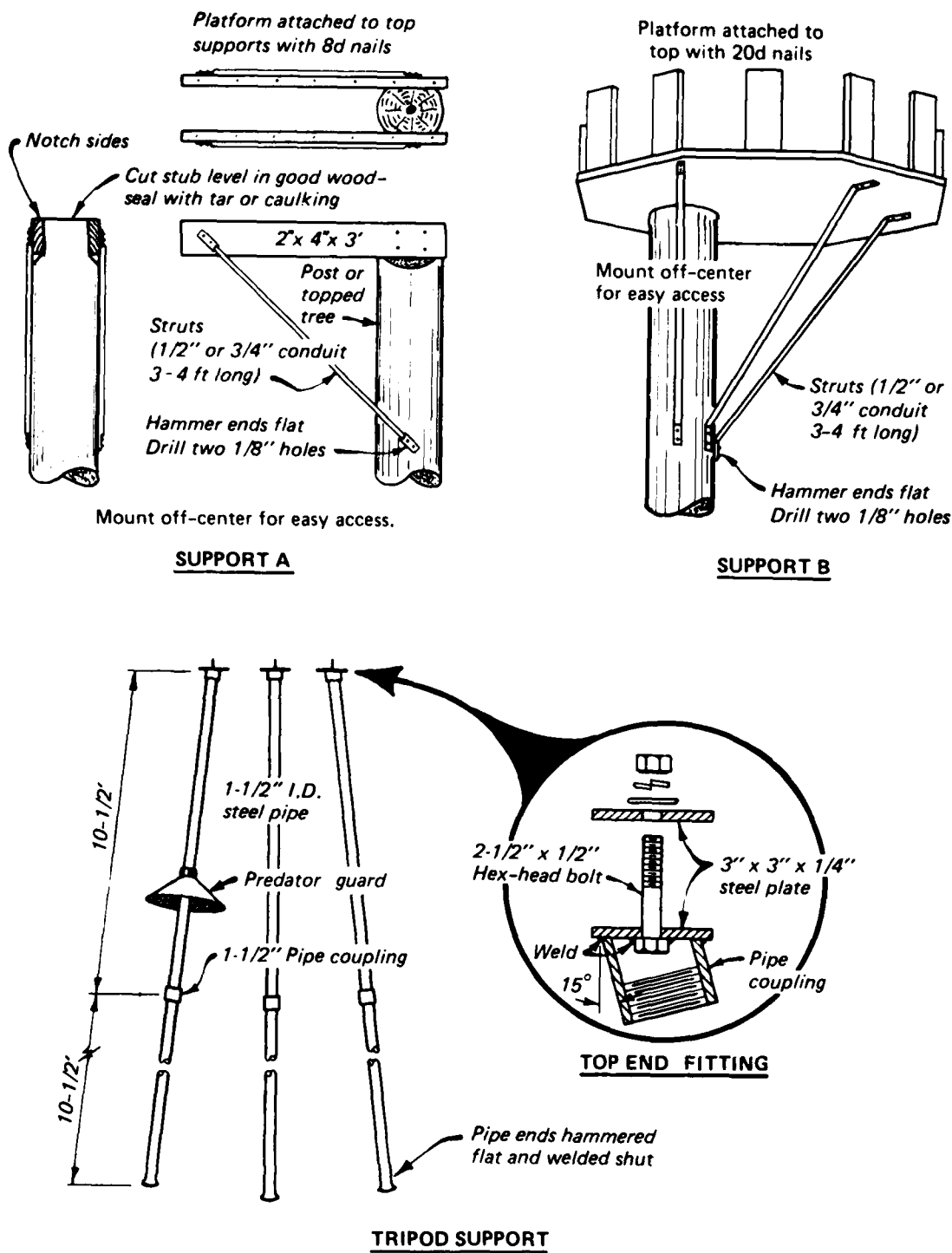

Figure 4. Design specifications for 3 types of supports used with a solid base osprey platform (after guidelines provided by Thomas U. Fraser, Sr., Conservation for Survival)

tree. The platform is nailed to the horizontal supports using 8d or 10d nails. An alternative method for attachment is to use 3 struts for support and nail the platform directly to the top of a pole (Fig. 4, Support B). Mounting the platform off-center facilitates access by the investigator.

Tripod support. The solid base platform can also be mounted on tripod legs made of 1-1/2-in. I.D. galvanized steel pipe (Fig. 4). A 21-ft length of pipe is first cut in half to form an upper and lower section of each leg, and the upper section is threaded at both ends to receive couplings. The lower section is threaded at the top end, and the bottom end is hammered flat and welded shut. Top-end fittings, each made from a pipe coupling that has been cut off at a 15-deg angle to the perpendicular, are threaded onto the upper section of each leg (see detail, Fig. 4). A 3- x 3- x 1/4-in. steel plate with a 1/2-in.-diam center hole is welded to the cut end of the coupling, and a 2-1/2- x 1/2-in. hex-head bolt is placed through the hole and welded to the plate.

The tripod platform is assembled at the installation site. A boat will be required to reach an overwater site and to hold a ladder from which personnel can work. The tripod legs are first positioned to form an equilateral triangle, with the lower section of each leg approximately 9 ft from the others. The sections are driven into the substrate (a wooden block should be used to protect the threads when hammering) until the top of the lower leg is at the surface of the water. The upper section is then attached to the lower section with a 1-1/2-in. pipe coupling.

The platform base is mounted on top of the legs by inserting the bolts through the predrilled 1/2-in.-diam holes at each point of attachment; two bolt holes at each point will allow flexibility in leveling the platform. A 3- x 3- x 1/4-in. steel plate with a 1/2-in.-diam hole through the center, a flat washer, lockwasher, and hexnut are placed over each hex-head bolt to hold the platform base securely in place. The platform may be reinforced by attaching three 27-in. lengths of 1/4- x 3/4-in. steel strapping to the bottom; a hole is drilled at the ends of each strap (distance between holes should be approximately 25 in.), and these are fitted over the hex-head bolts on top of the tripod legs before the platform is mounted. Cone-shaped sheet metal predator guards may be attached to each leg either before or after installation. These should be spaced 2-1/2 ft from the base of the platform.

Ring Platform

In coastal areas and many inland waterways, marine navigation aids provide potential nest sites in suitable habitat. For example, over two-thirds of the osprey nests in Chesapeake Bay are located on navigation aids and duck blinds (Henny et al. 1978). Though many markers, especially lighted aids, have adequate structure to support a nest, the nest often obstructs the light or hinders maintenance. Consequently, nests have traditionally been removed by U.S. Coast Guard (USCG) maintenance personnel (Reese 1970).

The TVA ring platform described here was designed to allow ospreys to nest on navigation aids without causing hazards or interfering with maintenance. USCG personnel from the Chattanooga, Tennessee, station cooperated in the design and emplacement of these platforms. The platform is essentially a steel ring with supports mounted to an antenna mast. Specifications for construction and installation are given below and in Figure 5; materials are listed in Table 3.

To construct the ring, a 1-in.-diam steel pipe is first bent into a 36-in.-diam circle on a conduit bender, and the butt ends are welded together. Four 36- to 38-in. lengths of 3/8-in.-diam steel rod are then cut and welded in a spoke-like pattern to the bottom of the ring; the first rod attached should be 36 in. long, and each subsequent rod welded will be slightly longer than the previous one to overlap properly and make complete connection with opposite points on the ring. Vertical retainers for holding nesting material consist of six 15-in. lengths of 3/8-in. steel rod spaced at approximately 19-in. intervals along the top edge of the ring; holes are drilled in the top of the ring, and rods are inserted and welded into place. A 5-ft length of 1/2-in.-diam steel rod is welded at a 45-deg angle from the ring plane to form a lower support; a 3-in. section of the lower end of the rod is bent at an angle to be parallel with the antenna mast support structure.

U-bolts with backing plates are used to attach the platform to an antenna mast. A 3/8- x 4- x 6-in. steel plate is first welded to the ring, and four 1/2-in. holes are drilled in the plate to receive 2 U-bolts; the 3-in. bend in the support rod is also welded to a backing plate. U-bolts are used to attach the support rod backing plate to the antenna. The mast is then fastened to a navigation aid piling using four 6-in. lag bolts spaced at 2-ft intervals on the lower end of the mast.

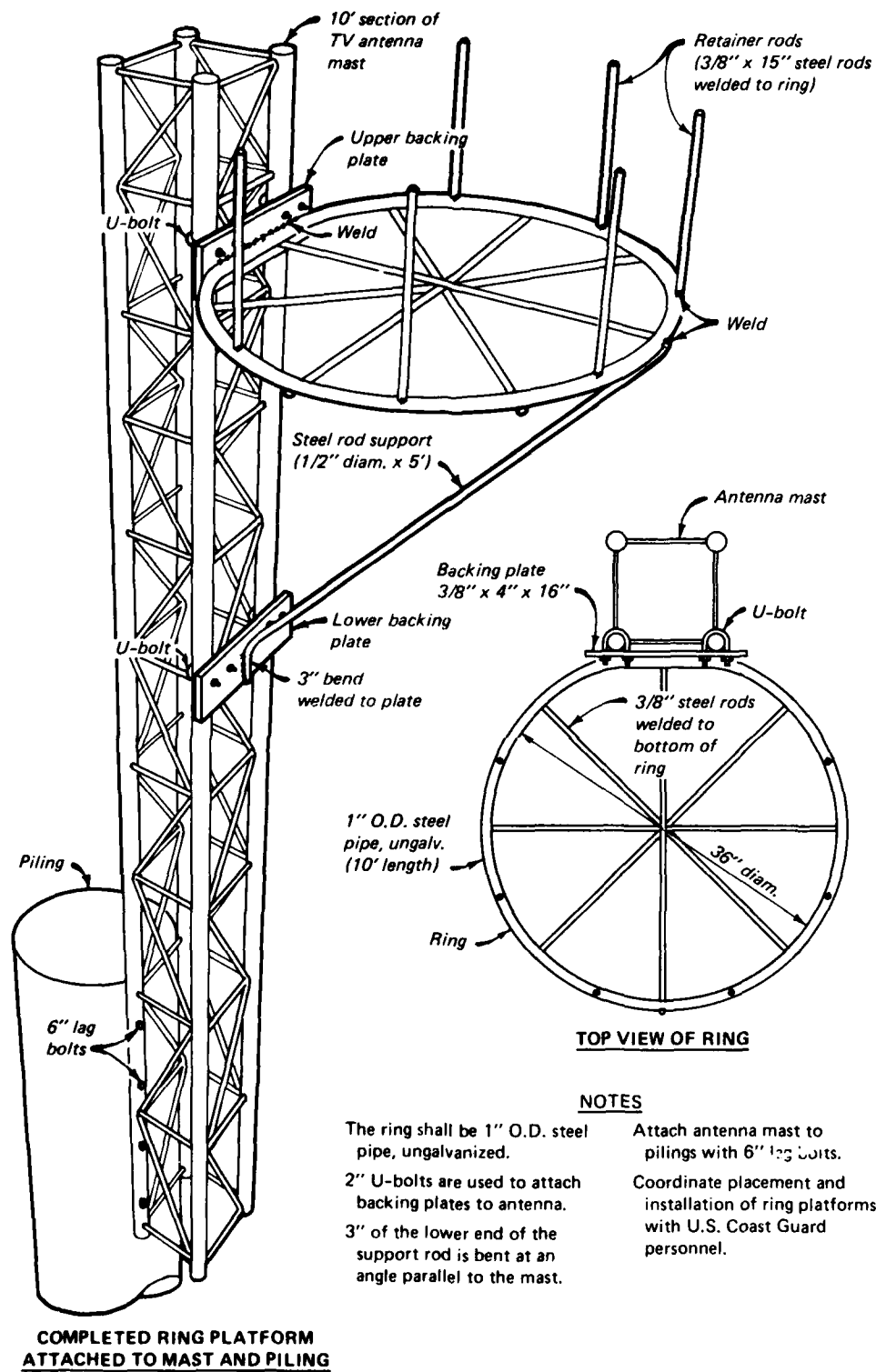

Figure 5. Design specifications for a ring nesting platform for ospreys that can be installed on marine navigation aids

Table 3. Materials needed to construct a ring platform for ospreys

Item	Quantity
Steel pipe, ungalvanized, 1-in. O.D. × 10 ft	1
Steel rod, 3/8-in. diam, 36- to 38-in. sections	4
Steel rod, 3/8-in. diam, 15-in. lengths	6
Steel rod, 1/2-in. diam, 5 ft	1
U-bolts, 2-in., with hex-head nuts, washers, and lockwashers	4
Steel plate, 3/8 × 4 × 16 in.	1
Backing plate (for use with U-bolt on lower support)	1
Hex-head lag bolt, 1/2-in. diam × 6 in.	4

Sanibel Tripod

The Sanibel-Captiva Conservation Foundation in Sanibel, Florida, and the International Osprey Foundation have recently cooperated in the design of a lightweight, portable tripod-type osprey nesting structure (Figs. 6-7, Table 4). This platform, referred to herein as the Sanibel Tripod, is most suitable for use in remote areas where carrying a heavy pole to the site is infeasible, and in wet areas with soft substrates such as marshes and swamps (Webb and Lloyd, in press).

Each leg of the tripod is 24 ft long and consists of 4 connected pieces of 2- × 4-in. lumber (three 12-ft lengths and one 8-ft length). Two of the 12-ft pieces are fitted together and are attached to an 8-ft/12-ft piece so that there is a 4-ft-long, 2- × 4-in. extension at the top of the leg (Fig. 6). The legs are assembled by fastening the 2- × 4-in. sections together with 12d nails and latex glue. Joints where the 2 × 4's butt together are staggered and strengthened with splice plates made of strips of waterproof plywood that are glued and nailed across each joint. Five holes are then drilled in the top of each leg; the first 4 holes are 1/8 in. in diameter to receive wire; the fifth hole is 9/16 in. in diameter and is drilled through two 2 × 4's to receive a metal rod (part of the spider hinge).

Removable steps can be installed on one leg of the tripod to facilitate nest monitoring and banding. This requires attaching 7 "step lugs" (1- × 2- × 3-in. wood blocks which support the removable steps) to the underside of the leg at 2-ft intervals. The bottom 6 steps are 5-3/4 in. wide to support one foot at a time, and the top step is 9 in. wide to support both feet while the investigator is at nest level. Construction details for the steps are shown in Figure 7.

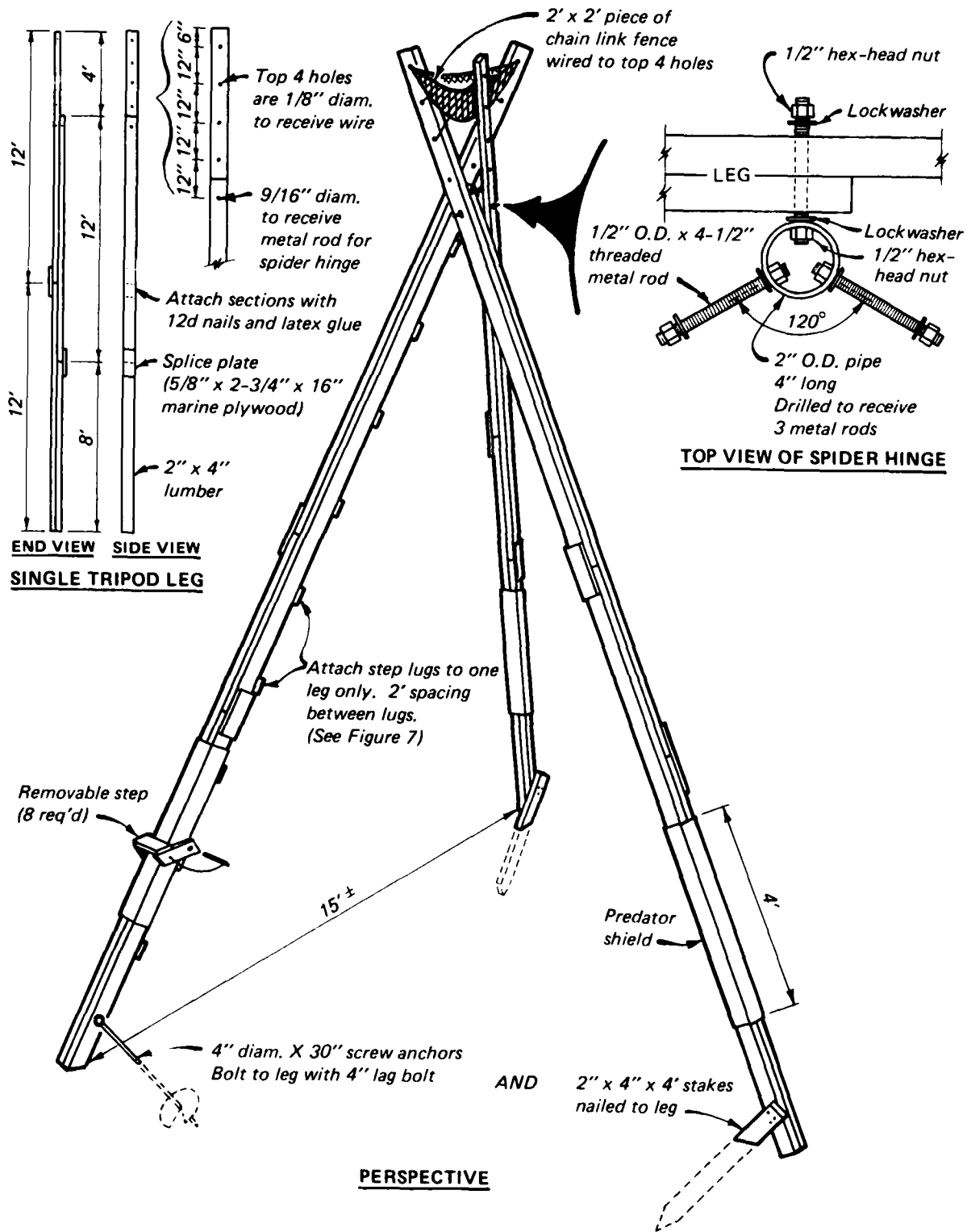
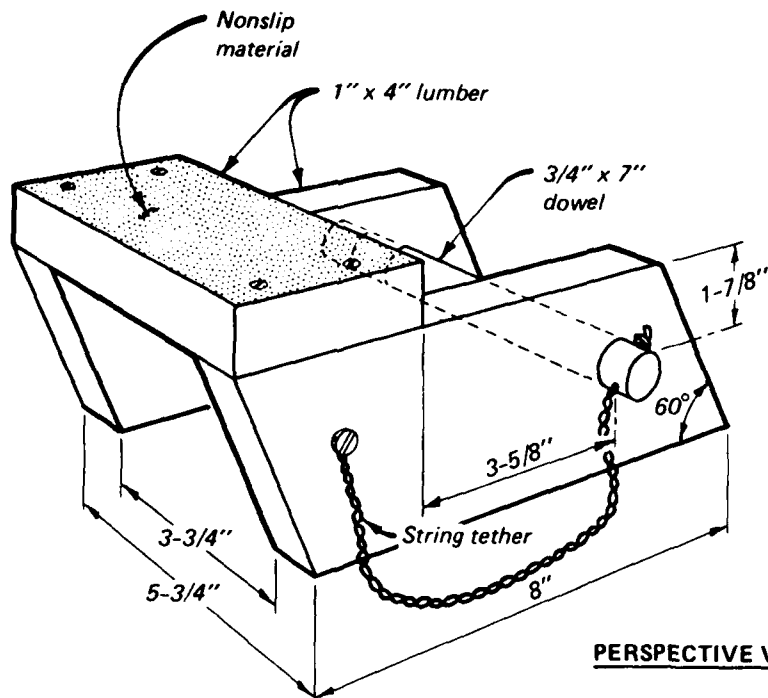

Figure 6. Design specifications for a Sanibel Tripod nesting platform for ospreys (after Webb and Lloyd, in press)



NOTES

- Materials are 1 x 4" stock.
- Parts are glued and fastened with wood screws.
- String tether keeps dowel with step.
- Step lugs are attached to one leg of tripod to keep steps in place.
- Top step is 9" wide to support both feet of investigator.
- Nonslip material should be glued to steps.

PERSPECTIVE VIEW OF STEP

Figure 7. Construction details and materials for removable steps attached to one leg of a Sanibel Tripod (after Webb and Lloyd, in press)

Table 4. Materials needed to construct a Sanibel Tripod nesting platform

Item	Quantity
Lumber, pressure-treated	
2 x 4 in. x 12 ft	9
2 x 4 in. x 8 ft	3
2 x 4 in. x 4 ft (for stakes)	3
Marine plywood, 5/8 x 2-3/4 x 16 in. (for splice plates)	6
Hardware	
Screw anchors (mobile home), 4-in. diam x 30 in.	3
Lag bolts, 1/2 x 4 in.	3
Pipe, galvanized, 2 x 4 in.	1
Threaded steel rod, 1/2 x 4-1/2 in.	3
Hexnuts, 1/2-in.	6
Washer, 1/2-in.	3
Chain-link fencing, 2 x 2 ft	1
Wire, galvanized, 12- to 14-ga	20 ft
Nails, common galvanized, 6d	1/2 lb
Nails, common galvanized, 12d	1/2 lb
Sheet aluminum, 4-ft length	1
Miscellaneous	
Latex glue	2 tubes
Step lugs, 1- x 2- x 3-in. wood blocks	7
Steps (materials given in Fig. 7)	7

The legs are hinged together at the site with a "spider hinge" made of a 4-in.-long piece of 2-in. O.D. pipe that is drilled and tapped to receive three 1/2-in. O.D. × 4-1/2-in. threaded metal rods. A 1/2-in. hex-head nut is screwed onto the end of each rod inside the 2-in. pipe. The rods are inserted into the 9/16-in. hole in each leg, and a 1/2-in. lockwasher and nut are secured to the outside. Each leg thus pivots about a rod in a plane at 90 deg to the axis of the rod. After the tripod is erected, a 2- × 2-ft piece of chain-link fence is placed on top and wired to the legs through the smaller holes above the spider hinge; this forms a firm base for nesting materials.

To secure the tripod firmly to the substrate, pressure-treated stakes (2 × 4 in. × 4 ft) are driven into the soil at approximately a 30-deg angle toward the tripod center and nailed to each leg. In addition, a screw anchor is twisted into the ground and bolted to each leg with a 4-in. lag bolt. Aluminum or sheet metal predator shields can then be attached to each leg.

Power Poles

Nest construction on power poles, especially those supporting distribution lines, has resulted in osprey electrocutions and power interruptions caused by nest material contacting conductors (Ansell and Smith 1980). However, ospreys have frequently nested successfully on power poles (Melquist 1974, Van Daele and Van Daele 1982), and potentially hazardous nests can be eliminated by erecting elevated platforms a safe distance above the lines (Van Daele 1980, Olendorff et al. 1981). A platform can be bolted onto two 2- × 6-in. boards, which are mounted on opposite sides of the pole and are long enough to elevate the nest at least 6 ft above the powerlines (L. J. Van Daele, Alaska Department of Game and Fish, pers. commun., 1983). This operation usually requires a cooperative effort with the utility company serving the location. Wildlife managers should provide platforms to be installed by company personnel, who prefer this procedure for maintaining safety standards.

In an area of breeding activity, ospreys should be discouraged from nesting on poles supporting transformers and lines less than 6 ft apart. Van Daele et al. (1980) recommended 2 nesting discouragement devices that are easy to construct and effective in preventing osprey usage (Fig. 8). The simplest device is a series of 3-ft-long pieces of 2- × 2-in. lumber spaced 20 in. apart and bolted or nailed perpendicular to the crossarms. Another

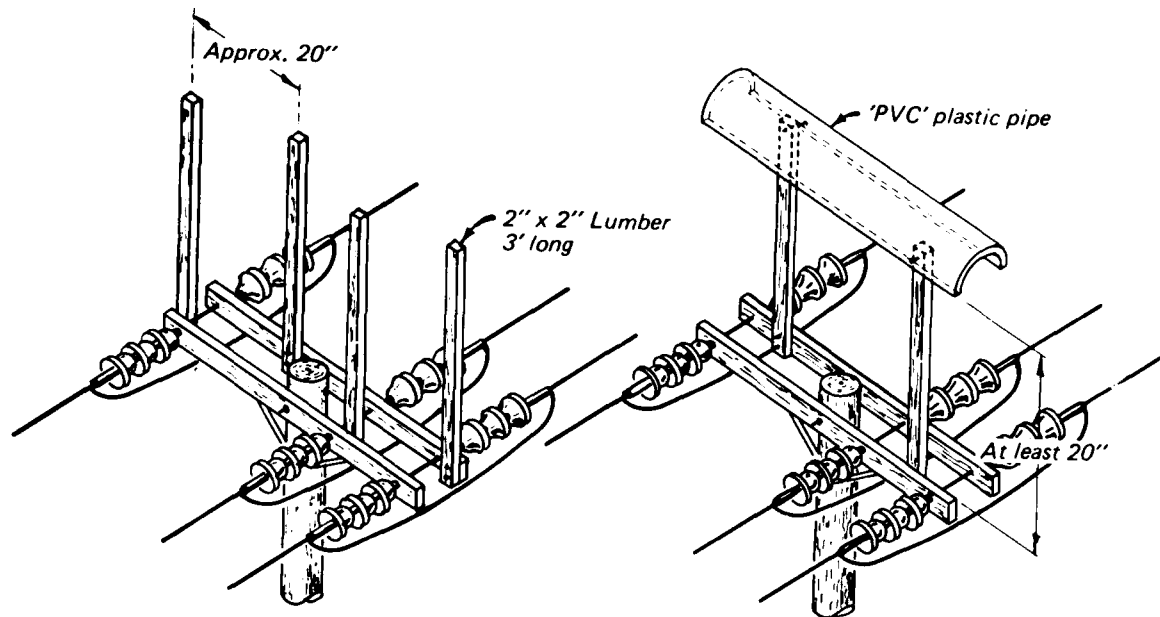

Figure 8. Osprey nesting discouragement devices for use on power poles (from Van Daele et al. 1980)

device can be made of a section of PVC pipe, which is cut the same length as the crossarms and raised on two 2- x 2-in. x 2-ft boards a minimum of 20 in. above the crossarms. The boards are located at opposite ends, one on each crossarm, and attached with screws or bolts to the crossarm and the inside of the pipe.

LOCATION

Sites selected for platform placement should have abundant fish populations, clear and/or shallow water, isolation from human disturbance, and vegetation or terrain features that will not be higher than the nest platform (Evans 1982). Highest success will occur in habitats fulfilling all other requirements but lacking suitable nest substrates. Platforms should be spaced at least 300 yd apart to avoid use of 2 platforms by a single pair.

Attracting ospreys to nest in an area with low fish populations or contamination from heavy metals, PCB's, chlorinated hydrocarbons, or other pollutants may be detrimental to regional populations (Wiemeyer et al. 1980); therefore, site selection should always include an examination of the available prey base and water quality conditions. Platforms should not be located

near nests or hunting perches of bald eagles (*Haliaeetus leucocephalus*), golden eagles (*Aquila chrysaetos*), peregrine falcons (*Falco peregrinus*), other large raptors, or crows and ravens (*Corvus* spp.) because interspecific competition or predation may be detrimental (Ogden 1975). Areas susceptible to unusually high winds generated by local topographic features should also be avoided.

Platforms should be accessible for annual maintenance and data collection but should not be near human activity centers such as campgrounds, boat ramps, houses, roads, or areas with high sport or commercial fishing activity. Location of platforms within 4 to 5 miles of fish hatcheries or private ponds may create depredation problems and undesirable public relations.

MAINTENANCE

If properly constructed and installed, platforms will be essentially free of maintenance, but poles and tripods subject to ice damage are more likely to need repair. All artificial structures and platforms should be inspected and repaired in late winter or early spring before return of the nesting birds.

PERSONNEL AND COSTS

It is recommended that project personnel acquire materials and construct platform bases during the winter so that no time is lost installing the structures prior to the nesting season. Minimal storage space is needed except for poles, which can be stored outside. Personnel requirements provided below for construction and installation are rough estimates; material costs will vary regionally.

To construct and install a frame platform on an artificial pole requires 5 to 6 man-hours; estimated 1983 costs were \$38 for each pressure-treated pole and \$17 for platform materials (Bob Adair, pers. commun., 1983). The solid base platform can be constructed and mounted on a snag or tree in 1 to 2 man-hours. Construction of this platform and tripod legs requires 2 to 3 man-hours, and installation can be accomplished by a 3-man crew in 1/2 hour under optimal conditions. Estimated 1983 cost for this assembly was approximately \$75 (Thomas U. Fraser, Sr., pers. commun., 1983).

Materials for the ring platform cost approximately \$60. One man-hour is needed for construction, and installation requires 1/2 man-hour with assistance of the USCG or other agency personnel responsible for maintenance of

marine navigation aids. Cost of materials for the Sanibel Tripod is about \$70; assembly and installation require 2 man-days.

CAUTIONS AND LIMITATIONS

An artificial nest platform program should not be initiated until other limiting factors have been eliminated and the need for additional nest substrates has been clearly demonstrated. Since available food supplies are often a significant factor, managers need to determine that existing prey populations are adequate to support increased osprey populations (Olendorff and Stoddart 1974, Stahlecker 1979).

Erection of additional platform nests may result in rapid or high levels of occupancy but do not always reflect a local nesting population increase (Snyder 1978). Poor site selection may attract ospreys away from natural sites into areas with intense human activity. However, nest platforms incorporated into educational programs with distant viewing points may enhance public awareness of raptors and other wildlife. Platforms constructed at sites distant from established nests or in states without sizable nesting populations are unlikely to be successful unless a program is developed to introduce and artificially care for young birds (Hammer and Hatcher 1983). Additional cautions for platform placement are discussed under the topic headings Power Poles and Location.

PLATFORM SUCCESS

Several studies have shown artificial platforms to be readily accepted by ospreys. Occupancy rates have been recorded as 27% in Oregon (Henny et al. 1978), 32% (Airola and Shubert 1981) and 60% (Garber et al. 1974) in California, 55% in Michigan (Postupalsky 1978), 70% in Florida (Westall 1983), and from 58% (Reese 1977) to 82% (Rhodes 1972) in Chesapeake Bay, Maryland.

Some studies have reported greater productivity on artificial structures than on natural nest sites. Postupalsky (1978) reported 1.2 young/occupied platform nest compared with 0.6 for natural nests on the lower peninsula of Michigan. In Long Valley, Idaho, Van Daele and Van Daele (1982) found that productivity differed significantly between nests on snags and those on power poles and platforms; the number of young/active nest* was 2.4 for platforms,

* Active nest: a nest that contains at least 1 egg or one at which ospreys are apparently incubating eggs.

2.0 for power poles, 1.6 for live trees, and 1.2 for snags. Studies in Maryland (Rhodes 1977), Idaho (Van Daele and Van Daele 1982), and Florida (Westall 1983) showed that platforms produced 1.4 to 2.4 young/active nest over periods of several years. Postupalsky and Stackpole (1974) found an average productivity of 1.2 young/occupied nest during a 10-year study in Michigan, and Eckstein et al. (1979) found platforms to yield an average of 1.1 young/occupied nest for a 3-year period in Wisconsin. These rates are well within the range of 0.95 to 1.3 young/active nest, the minimum productivity needed to maintain osprey population stability (Henny and Wight 1969).

EVALUATION

Effectiveness of a platform program will be determined largely by the fulfillment of management objectives. Platforms erected for relocation, substitution, or replacement of existing nest sites are successful if ospreys use the new sites. Platform use can therefore be measured as percent occupancy by nesting (territorial) pairs.*

Nest success is evaluated by the number of young birds produced or fledged per nest. Productivity can be calculated as the average number of young produced or fledged per occupied nest and will include some nonlaying birds. Calculations of productivity should include data for all territorial pairs because individual pairs may, under certain conditions, refrain from breeding in some years (Postupalsky 1974). Occasionally, a pair will set up "housekeeping" and behave as though they were nesting. Based on a review of 3 nest studies, Henny and Van Velzen (1972) estimated that housekeeping birds represented an average of 6.2% of the population present on nesting grounds. However, the production rates are usually quite similar whether including or excluding the small segment of nonlaying pairs (Henny 1977).

Postupalsky (1974) recommended a minimum of 2 checks of each occupied nest per breeding season in population surveys of large raptors in northern temperate regions. The first check should be made during early incubation to count the number of territorial pairs. The number of young raised should be censused just prior to the time young are due to fledge. The presence of eggshells can be used to indicate that an egg was laid, and an osprey sitting on

* Nesting (territorial) pair: mated pair present on territory with nest (platform) whether breeding or not.

a nest can be considered evidence of incubating eggs, as ospreys do not leave the nest untended. Care must be taken to create a minimum of disturbance while collecting data.

The methods employed to determine nest use and productivity should be those which best serve to obtain the required data. The same methods should be used consistently to provide reliable year-to-year comparisons of osprey production, and the parameters measured should achieve comparability with other osprey studies. Assistance in data collection and recordkeeping may often be obtained from the appropriate State game and fish office or Federal conservation agency. An osprey nest survey form modified from a form used by the Tennessee Valley Authority is provided as Appendix A. Refer to the osprey species account, Section 4.3.1 of this manual, for a discussion of terminology relating to osprey nesting activity.

It is recommended that nesting data be provided annually to the International Osprey Foundation, Inc., 289 Southwinds, Sanibel, Florida 33957. This organization compiles records of osprey nesting activities in North America. It has also initiated a color-banding program and may be contacted for advice and assistance in banding chicks.

LITERATURE CITED

- Airola, D. A., and N. Shubert. 1981. Reproductive success, nest site selection and management of ospreys at Lake Almanor, California, 1969-1980. *Cal-Neva Wildl. Trans.* 1981:79-85.
- Ansell, A. R., and W. E. Smith. 1980. Raptor protection activities of the Idaho Power Company. Pages 56-70 In R. P. Howard and J. F. Gore, eds. *Proc. of a Workshop on Raptors and Energy Development.* U.S. Fish and Wildl. Serv., Boise, Idaho. 125 pp.
- Beddow, T. E. (In Press). Recovery of natural nesting osprey in the Tennessee Valley. *Proc. Southeast. U.S. and Caribbean Osprey Symposium*, June 3-6, 1983, Sanibel, Fla.
- Bent, A. C. 1937. *Life Histories of North American Birds of Prey.* Vol I. U.S. Nat. Mus. Bull. No. 167.
- Dunstan, T. C. 1973. The biology of ospreys in Minnesota. *Loon* 45:108-113.
- Eckstein, R. G., P. V. Vanderschaegen, and F. L. Johnson. 1979. Osprey nesting platforms in north central Wisconsin. *Passenger Pigeon* 41:145-148.
- Evans, D. L. 1982. Status report on twelve raptors. U.S. Fish and Wildl. Serv., Special Sci. Rep. No. 238. 68 pp.
- French, J. M., and J. R. Koplín. 1977. Distribution, abundance, and breeding status of ospreys in northwestern California. *Proc. North Am. Osprey Res. Conf.* U.S. Natl. Park Serv. Trans. Proc. Ser. No. 2:223-240.
- Gale, M., and L. A. Forbis. 1974. A habitat management plan for osprey on the Klamath National Forest. *USDA For. Serv., Calif. Reg.* 46 pp.
- Garber, D. P., J. R. Koplín, and J. R. Kahl. 1974. Osprey management on the Lassen National Forest, California. Pages 119-122 In F. N. Hamerstrom, Jr., B. E. Harrell, and R. R. Olendorff, eds. *Management of Raptors.* Raptor Res. Rep. No. 2. 146 pp.
- Hammer, D. A. 1981. Osprey reintroduction in the Tennessee Valley. *Proc. Nongame and Endangered Wild. Symposium*, Aug. 13-14, Athens, Ga.
- _____, and R. M. Hatcher. 1983. Restoring osprey populations by hacking preflighted young. Pages 293-297 In D. M. Bird, ed. *Biology and Management of Bald Eagles and Ospreys.* Harpell Press, Ste. Anne de Bellevue, Quebec. 325 pp.
- Henny, C. J. 1977. Research management, and status of the osprey in North America. Pages 199-222 In R. D. Chancellor, ed. *Int. Counc. for Bird Preservation World Birds of Prey Conf.*, Vienna, Austria. 442 pp.
- _____. 1983. Distribution and abundance of nesting ospreys in the United States. Pages 175-186 In D. M. Bird, ed. *Biology and Management of Bald Eagles and Ospreys.* Harpell Press, Ste. Anne de Bellevue, Quebec. 325 pp.
- _____, and D. W. Anderson. 1979. Osprey distribution, abundance, and status in western North America. Vol III: The Baja California and Gulf of California population. *Bull. South. Calif. Acad. Sci.* 78:89-106.

- Henny, C. J., M. A. Byrd, J. A. Jacobs, P. D. McLain, M. R. Todd, and B. F. Halla. 1977. Mid-Atlantic Coast osprey populations, present numbers, productivity, pollutant contamination, and status. *J. Wildl. Manage.* 41:254-265.
- _____, J. A. Collins, and W. J. Deibert. 1978. Osprey distribution, abundance, and status in western North America. Vol II: The Oregon population. *The Murrelet* 59:14-25.
- _____, and W. T. Van Velzen. 1972. Migration patterns and wintering localities of American ospreys. *J. Wildl. Manage.* 36:1133-1141.
- _____, and H. M. Wight. 1969. An endangered osprey population: Estimates of mortality and production. *Auk* 86:188-198.
- Jamieson, I., N. Seymour, and R. P. Bancroft. 1982. Time and activity budgets of ospreys nesting in northeastern Nova Scotia. *Condor* 84:439-441.
- Kahl, J. R. 1972. Osprey management on the Lassen National Forest. *Cal-Neva Wildl. Trans.* 1972:7-13.
- _____, and D. P. Garber. 1971. Feathered fishermen of Eagle Lake. *Outdoor Calif.* 33:4-5.
- Kennedy, R. S. 1977. The status of the osprey in tidewater Virginia, 1970-1971. *Proc. North Am. Osprey Res. Conf. U.S. Natl. Park Serv. Trans. Proc. Ser. No. 2:121-133.*
- Melquist, W. E. 1974. Nesting success and chemical contamination in northern Idaho and northeastern Washington ospreys. M.S. Thesis, Univ. Idaho, Moscow. 105 pp.
- Ogden, J. C. 1975. Effects of bald eagle territoriality on nesting ospreys. *Wilson Bull.* 87:496-505.
- _____. 1977. Preliminary report on a study of Florida Bay ospreys. *Proc. North Am. Osprey Res. Conf. U.S. Natl. Park Serv. Trans. Proc. Ser. No. 2:143-151.*
- Olendorff, R. R., A. D. Miller, and R. N. Lehman. 1981. Suggested practices for raptor protection on power lines -- the state-of-the-art in 1982. *Raptor Res. Found., Inc. Raptor Res. Rep. No. 4.*
- _____, and J. W. Stoddart, Jr. 1974. Potential for management of raptor populations in western grasslands. Pages 44-88 *In* F. N. Hamerstrom, Jr., B. E. Harrell, and R. R. Olendorff, eds. *Management of Raptors. Raptor Res. Rep. No. 2.* 146 pp.
- Parnell, J. F., and R. Walton. 1977. Osprey reproductive success in southeastern North Carolina. *Proc. North Am. Osprey Res. Conf. U.S. Natl. Park Serv. Trans. Proc. Ser. No. 2:139-142.*
- Postupalsky, S. 1974. Raptor reproductive success: Some problems with methods, criteria, and terminology. Pages 21-31 *In* F. N. Hamerstrom, Jr., B. E. Harrell, and R. R. Olendorff, eds. *Management of Raptors. Raptor Res. Rep. No. 2.* 146 pp.
- _____. 1977. Status of the osprey in Michigan. *Proc. North Am. Osprey Res. Conf. U.S. Natl. Park Serv. Trans. Proc. Ser. No. 2: 153-165.*

- Postupalsky, S. 1978. Artificial nesting platforms for ospreys and bald eagles. Pages 33-45 In S. A. Temple, ed. Endangered Birds. Univ. Wis. Press, Madison. 466 pp.
- _____, and S. M. Stackpole. 1974. Artificial nesting platforms for ospreys in Michigan. Pages 105-117 In F. N. Hamerstrom, Jr., B. E. Harrell, and R. R. Olendorff, eds. Management of Raptors. Raptor Res. Rep. No. 2. 146 pp.
- Reese, J. G. 1970. Reproduction in a Chesapeake Bay osprey population. Auk 87:747-759.
- _____. 1977. Nesting success of ospreys in central Chesapeake Bay. Proc. North Am. Osprey Res. Conf. U.S. Natl. Park Serv. Trans. Proc. Ser. No. 2:109-113.
- Rhodes, L. I. 1972. Success of osprey nest structures at Martin National Wildlife Refuge. J. Wildl. Manage. 36:1296-1299.
- _____. 1977. An osprey population aided by nest structures. Proc. North Am. Osprey Res. Conf. U.S. Natl. Park Serv. Trans. Proc. Ser. No. 2:77-83.
- Roberts, H. B. 1970. Management of the American osprey on the Deschutes National Forest, Oregon. Raptor Res. News 4:168-177.
- Schmid, F. C. 1966. The status of the osprey in Cape May County, New Jersey, between 1939 and 1963. Chesapeake Sci. 7:220-223.
- Snyder, N. F. R. 1978. Increasing reproductive effort and success by reducing nest-site limitations. Pages 27-33 In S. A. Temple, ed. Endangered Birds. Univ. Wis. Press, Madison. 466 pp.
- Stahlecker, D. W. 1979. Raptor use of nest boxes and platforms on transmission towers. Wildl. Soc. Bull. 7:59-62.
- Szaro, R. C. 1972. The breeding biology of the osprey (*Pandion haliaetus*) at Seahorse Key, Florida. M.S. Thesis, Univ. Fla., Gainesville. 47 pp.
- Van Daele, L. J. 1980. Ospreys and power poles in Idaho. Pages 104-112 In R. P. Howard and J. F. Gore, eds. Proc. of a Workshop on Raptors and Energy Developments. U.S. Fish and Wildl. Serv., Boise, Idaho. 125 pp.
- _____, and H. A. Van Daele. 1982. Factors affecting the productivity of ospreys nesting in west-central Idaho. Condor 84:292-299.
- _____, _____, and D. R. Johnson. 1980. The status and management of ospreys nesting in Long Valley, Idaho. Univ. Idaho, Moscow. 49 pp.
- Webb, W. L., and A. H. Lloyd. (In Press). Design and use of tripods as osprey nest platforms. Proc. Southeast. U.S. and Caribbean Osprey Symposium, Sanibel, Fla.
- Westall, M. A. 1983. An osprey population aided by nest structures on Sanibel Island, Florida. Pages 287-291 In D. M. Bird, ed. Biology and Management of Bald Eagles and Ospreys. Harpell Press, Ste. Anne de Bellevue, Quebec. 325 pp.
- Wiemeyer, S. N., T. G. Lamont, and L. N. Locke. 1980. Residues of environmental pollutants and necropsy data for eastern United States ospreys, 1964-1973. Estuaries 3:155-167.

Zarn, M. 1974. Habitat management series for unique or endangered species --
osprey (*Pandion haliaetus carolinensis*). U.S. Bur. Land Manage. Rep.
No. 12.

APPENDIX A: OSPREY NEST SURVEY FORM

Observer _____ Year _____

Site number/Name _____

LOCATION

State _____ County _____ Lat. _____ Long. _____

Lake/Reservoir _____ River _____

Coast/Estuary _____ Other _____

Directions to Nest (attach Map) _____

NEST STRUCTURE

Artificial: Type _____

Natural: Tree species _____ Live/Dead _____

Elevation (above ground or water) _____

Distance to nearest water _____ Type _____

Distance to nearest human activity _____ Type/Intensity _____

Nest Material _____ Nest cup _____

NESTING ACTIVITY

Date nest initiated _____ Adults present _____

Arrival date _____ Number of eggs _____ Date laid _____

Number of young _____ Age _____ Date _____

Number of young fledged _____ Date _____

Date of last activity at nest _____

OTHER

Band numbers: Adults _____

Young _____

Other Markers _____

Food items in or around nest/pilot tree _____

Reaction of adults to nest inspection _____

Other raptor or corvid activity _____

Comments _____

END

10-8%

DTIC