

AD-A178 543

COMPARISON OF WHOLE-BODY SPECIFIC ABSORPTION RATE FOR
HUMAN PHANTOMS WITH AND WITHOUT SKELETAL FEATURES(U)
SCHOOL OF AEROSPACE MEDICINE BROOKS AFB TX W D HURT
MAY 86 USAFSAM-TP-86-1 F/G 6/18

1/1

UNCLASSIFIED

NL



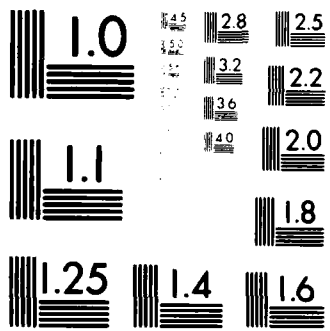

MICROCOPY RESOLUTION TEST CHART
NATIONAL BUREAU OF STANDARDS-1963-A

2

USAFSAM-TP-86-1

COMPARISON OF WHOLE-BODY SPECIFIC ABSORPTION RATE FOR HUMAN PHANTOMS WITH AND WITHOUT SKELETAL FEATURES

AD-A170 543

William D. Hurt, M.S.

DTIC
SELECTE
AUG 04 1986
S D
P D

May 1986

Final Technical Paper for Period January 1985 - December 1985

Approved for public release; distribution is unlimited.

DTIC FILE COPY

USAF SCHOOL OF AEROSPACE MEDICINE
Aerospace Medical Division (AFSC)
Brooks Air Force Base, TX 78235-5301



86 8 4 004

8c. ADDRESS (City, State, and ZIP Code)
 Aerospace Medical Division (AFSC)
 Brooks Air Force Base, TX 78235-5301

10 SOURCE OF FUNDING NUMBERS			
PROGRAM ELEMENT NO	PROJECT NO	TASK NO	WORK UNIT ACCESSION NO
62202F	7757	01	82

11 TITLE (Include Security Classification)
 Comparison of Whole-Body Specific Absorption Rate for Human Phantoms with and without Skeletal Features

12 PERSONAL AUTHOR(S)
 Hurt, William D.

13a. TYPE OF REPORT Final Technical Paper	13b. TIME COVERED FROM 1Jan85 to 31Dec85	14. DATE OF REPORT (Year, Month, Day) 1986, May	15. PAGE COUNT 8
--	---	--	---------------------

16 SUPPLEMENTARY NOTATION

17 COSATI CODES			18 SUBJECT TERMS (Continue on reverse if necessary and identify by block number)
FIELD	GROUP	SUB-GROUP	
06	18		
06	02		Radiofrequency Radiation

COMPARISON OF WHOLE-BODY SPECIFIC ABSORPTION RATE
FOR HUMAN PHANTOMS WITH AND WITHOUT SKELETAL FEATURES

INTRODUCTION

The most common biological effect of overexposure to radiofrequency radiation (RFR) fields may be described as an acute thermal burden. The extent of the effect depends primarily on the time rate of transfer of the energy to the biological specimen. The depth of penetration and the amount of incident energy absorbed varies as a function of the frequency of the incident radiation [1]. As the frequency decreases, the penetration of energy into biological tissue becomes deeper; however, wavelengths in the kilohertz (kHz) and lower megahertz (MHz) regions are so long with respect to the physical dimensions of the human subject that energy absorption is negligible. The purpose of this research was to measure the energy absorption in human phantoms when exposed to high-frequency (HF) band (20, 30, and 50 MHz) RFR fields.

MATERIALS AND METHODS

Two plastic models of an average man (1.75 m tall and 70 kg), one with complete skeletal features and one without, were filled with tissue-equivalent liquid (TEL). The TEL was composed of 97% water, 2.7% glycine, and .33% sodium chloride. The phantoms were centered above the septum of the transverse electromagnetic (TEM) mode RF exposure chamber [2]. The TEM cell was 9.14 m (30 ft) long, 2.82 m (9.25 ft) wide, and 1.45 m (4.75 ft) high, with a 1.83 m (6 ft) wide, thin, aluminum septum. Uniform fields with orthogonal electric (E) and magnetic (H) vectors exist throughout a 6.1 x 1.2 x 0.6 m (20 x 4 x 2 ft) exposure volume both above and below the septum. The driver stage of the Microwave Cavity Laboratories model 15022 transmitter was used to supply a nominal 50 W to the TEM cell at frequencies of 20, 30, and 50 MHz. Field measurements, E and H, were made with dipole and loop antennas and read on a Keithly model 600B electrometer. A set of 40-dB directional couplers were used to monitor power flow at the input and output of the TEM cell. These signals were fed through a Hewlett Packard (HP) model 3495A scanner into an HP model 3456A digital voltmeter which was monitored with an HP model 9825B desktop computer (Fig. 1). The incident power (P_I), the reflected power (P_R), and the power that flows out of the chamber into the 50-ohm load (P_L) were monitored. The power absorbed within the chamber is calculated as follows:

$$P = P_I - P_R - P_L . \quad (1)$$

The power absorbed by the phantom (P_{PH}) is given by:

$$P_{PH} = P_{PH+C} - P_C . \quad (2)$$

where P_C is the power absorbed in the TEM cell with the empty phantom in place, and P_{PH+C} is the power absorbed by the exposure chamber and the TEL-filled phantom.

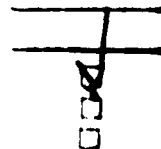

Availability Codes	
Dist	Avail and/or Special
A-1	

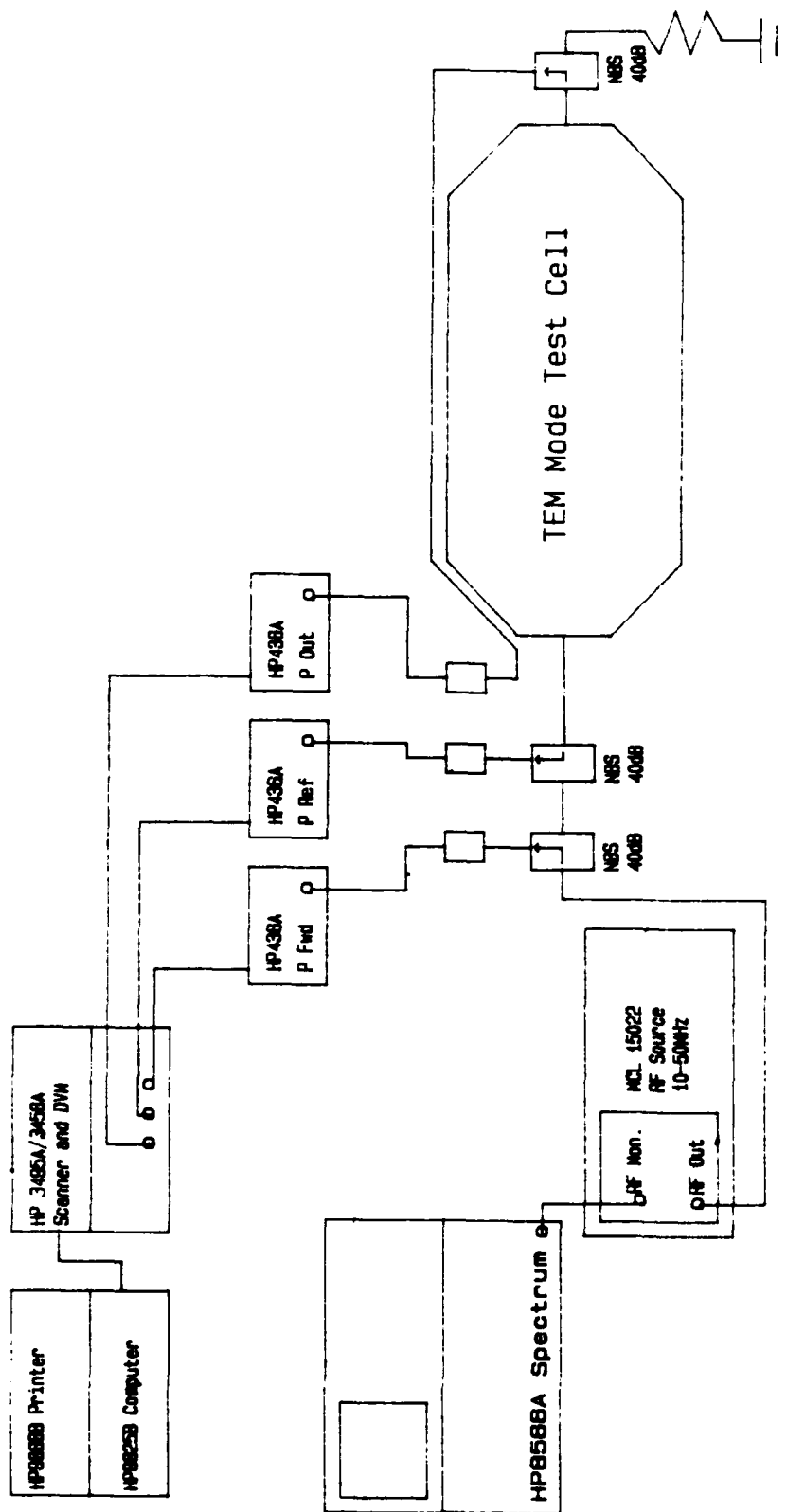

Figure 1. RF radiation research facility differential power measurement equipment block diagram.

RESULTS

The data for the normalized power absorbed with the phantoms in the TEM cell are shown in Table 1. The normalized power absorbed by the phantoms for each frequency and orientation was derived by subtracting the empty cell data from the data in Table 1. These data were converted to specific absorption rates (SAR) by dividing by the mass of the TEL-filled phantoms (56 kg for the phantom with bone and 68 kg for the one without). These results along with the pooled estimate of the standard deviations were calculated, and the results are presented in Table 2.

TABLE 1. POWER ABSORBED (W per mW/cm²)

Frequency (MHz)	<u>Phantom with Bone</u>				<u>Phantom without Bone</u>			
	H Polarization		K Polarization		H Polarization		K Polarization	
	PWR \pm SD	n	PWR \pm SD	n	PWR \pm SD	n	PWR \pm SD	n
50	2.12 \pm .11	16	2.11 \pm .09	18	2.18 \pm .12	20	2.25 \pm .11	16
30	1.40 \pm .14	4	1.36 \pm .14	4	1.56 \pm .12	7	1.53 \pm .19	6
20	1.61 \pm .10	4	1.55 \pm .10	4	1.64 \pm .16	8	1.56 \pm .14	6

The values for the empty TEM cell are 1.83 \pm .12(n=21), 1.45 \pm .15(n=7), and 1.54 \pm .13(n=4) for 50, 30, and 20 MHz respectively.

TABLE 2. SAR (mW/kg per mW/cm²)

Frequency (MHz)	<u>Phantom with Bone</u>				<u>Phantom without Bone</u>			
	H Polarization		K Polarization		H Polarization		K Polarization	
	SAR \pm SD	df	SAR \pm SD	df	SAR \pm SD	df	SAR \pm SD	df
50	5.2 \pm 2.1	35	5.0 \pm 1.9	37	5.1 \pm 1.8	39	6.2 \pm 1.7	35
30	-0.9 \pm 2.6	9	-1.6 \pm 2.6	9	1.6 \pm 2.0	12	1.2 \pm 2.5	11
20	1.3 \pm 1.6	10	.2 \pm 1.6	10	1.5 \pm 1.9	14	.3 \pm 1.6	12

DISCUSSION

Since none of the variance ratios exceeded the critical F values for the 0.01 confidence level, a two-tail t test for samples with equal variances was used to test the null hypotheses that the normalized SARs for the phantom with the skeletal features are equal to those of the boneless phantom. The data are displayed in Table 3. P represents the probability of having the test statistic (T) indicated as large or larger in size merely by chance. Therefore for these test conditions, significant differences can be demonstrated between the whole-body average SAR of the phantom with and without skeletal features for the 50-MHz K polarization case and both 30-MHz polarizations.

This conclusion, however, eases concern about the appropriateness of using homogeneous models to predict whole-body average SARs in humans because it indicates that this model will overestimate the SAR for HF fields.

TABLE 3. T TEST FOR NULL HYPOTHESES THAT SARs ARE EQUAL

Frequency (MHz)	H Polarization			K Polarization		
	T	df	P	T	df	P
50	.22	72	.83	-2.8	70	.01
30	-2.5	19	.02	-2.4	18	.03
20	-.27	22	.79	-.16	20	.87

REFERENCES

1. Salati, O. M., A. Anne, and H. P. Schwan. Radiofrequency radiation hazards. *Electronics Ind* 21(11):96-101 (1962).
2. Mitchell, J. C. A radiofrequency radiation exposure apparatus. SAM-TR-70-43, 1970.
3. Walpole, R. E. and R. H. Myers. *Probability and statistics for engineers and scientist*. New York: MacMillan Publishing Co., 1972.

END

Dritic

8-86