

AD-A169 442

LINEAR ELASTIC FRACTURE TESTING: CURRENT STATUS WITHIN 1/1
ASTM COMMITTEE E-24 ON FRACTURE(U) ARMY CLOSE COMBAT
ARMAMENTS CENTER WATERVLIET NY J H UNDERWOOD APR 86
ARCCB-TR-86015 F/G 20/11 NL

UNCLASSIFIED

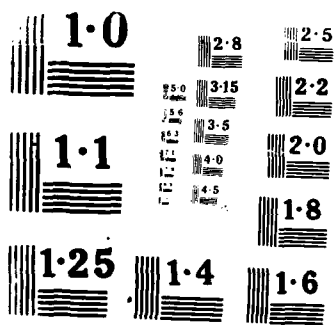



NAI 13: 91-
RE

AD-A169 442

12

AD

TECHNICAL REPORT ARCCB-TR-86015

**LINEAR ELASTIC FRACTURE TESTING :
CURRENT STATUS WITHIN ASTM COMMITTEE
E-24 ON FRACTURE**

JOHN H. UNDERWOOD

DTIC
ELECTE
JUL 3 1986
B

APRIL 1986



**US ARMY ARMAMENT RESEARCH AND DEVELOPMENT CENTER
CLOSE COMBAT ARMAMENTS CENTER
BENET WEAPONS LABORATORY
WATERVLIET, N.Y. 12189-4050**

APPROVED FOR PUBLIC RELEASE; DISTRIBUTION UNLIMITED

FILE COPY

DISCLAIMER

The findings in this report are not to be construed as an official Department of the Army position unless so designated by other authorized documents.

The use of trade name(s) and/or manufacturer(s) does not constitute an official indorsement or approval.

DESTRUCTION NOTICE

For classified documents, follow the procedures in DoD 5200.22-M, Industrial Security Manual, Section II-19 or DoD 5200.1-R, Information Security Program Regulation, Chapter IX.

For unclassified, limited documents, destroy by any method that will prevent disclosure of contents or reconstruction of the document.

For unclassified, unlimited documents, destroy when the report is no longer needed. Do not return it to the originator.

REPORT DOCUMENTATION PAGE		READ INSTRUCTIONS BEFORE COMPLETING FORM
1. REPORT NUMBER ARCCB-TR-86015	2. GOVT ACCESSION NO. ADA 169442	3. RECIPIENT'S CATALOG NUMBER
4. TITLE (and Subtitle) LINEAR ELASTIC FRACTURE TESTING: CURRENT STATUS WITHIN ASTM COMMITTEE E-24 ON FRACTURE		5. TYPE OF REPORT & PERIOD COVERED
		6. PERFORMING ORG. REPORT NUMBER
7. AUTHOR(s) John H. Underwood		8. CONTRACT OR GRANT NUMBER(s)
9. PERFORMING ORGANIZATION NAME AND ADDRESS US Army Armament Research & Development Center Benet Weapons Laboratory, SMCAR-CCB-TL Watervliet, NY 12189-4050		10. PROGRAM ELEMENT, PROJECT, TASK AREA & WORK UNIT NUMBERS AMCMS NO. 7280123000 PRON NO. 1A52N5L51A1A
11. CONTROLLING OFFICE NAME AND ADDRESS US Army Armament Research & Development Center Close Combat Armaments Center Dover, NJ 07801-5001		12. REPORT DATE April 1986
14. MONITORING AGENCY NAME & ADDRESS (if different from Controlling Office)		13. NUMBER OF PAGES 15
		15. SECURITY CLASS. (of this report) Unclassified
		15a. DECLASSIFICATION/DOWNGRADING SCHEDULE
16. DISTRIBUTION STATEMENT (of this Report) Approved for Public Release; Distribution Unlimited		
17. DISTRIBUTION STATEMENT (of the abstract entered in Block 20, if different from Report)		
18. SUPPLEMENTARY NOTES		
19. KEY WORDS (Continue on reverse side if necessary and identify by block number) Elastic Stress Fracture Mechanics Test Methods Pressure Vessel		
20. ABSTRACT (Continue on reverse side if necessary and identify by block number) The current status of elastic-stress-controlled fracture testing within ASTM is summarized, including example test results from high-strength steel forgings used for cannon. Plane-strain fracture toughness test methods were emphasized. Areas for future work were also discussed, including rapid crack growth tests, correlative tests, and tests for composite materials.		

TABLE OF CONTENTS

	<u>Page</u>
THE NEED: THINGS BREAK!	1
CURRENT: ANYTHING CAN BE TESTED	3
FUTURE: TEST METHODS TO COVER COMPLEX FRACTURES	5
REFERENCES	8

LIST OF ILLUSTRATIONS

1. Elastic-stress-controlled fragmentation failure of a high strength steel cannon due to service loading.	9
2. Plastic-deformation-controlled rupture of a high strength steel cannon due to overload.	10
3. Center-cracked tension panel and displacement gage for R-curve testing.	11
4. Crack-line loaded compact-type specimen for R-curve testing.	12
5. Three test specimens for plane-strain fracture toughness, K_{Ic} , testing. (a) Bend specimen and test arrangement. (b) Arc tension specimen. (c) Disk-shaped compact specimen.	13
6. Complex surface crack growth in an aluminum plane: starter notch - semicircular; fatigue cracking - semicircular; stable cracking - complex shape; fatigue cracking - semielliptical; final failure.	14

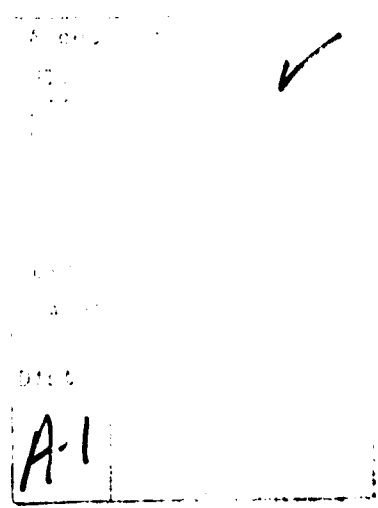

THE NEED: THINGS BREAK!

Unfortunately, it is easy to show the need for attention to linear elastic fracture processes. Many reviews of the field of fracture have described failures of key structural components and whole structures that could have been prevented with proper attention to linear elastic fracture mechanics. A series of overview articles in ASTM Standardization News a few years ago (ref 1) described the history of ASTM Committee E-24, and failures were a key part of that history as well as a driving force in the development of E-24 and the field of fracture mechanics. Many of the important failures involved the aerospace and power generation industries. However, linear elastic fracture may always be present as an unwelcome part of structural behavior because of competing requirements and pressures imposed on structural systems. If size and weight of structures had no limits, the pressure to use high strength materials - which are prone to linear elastic fracture - would not be present. But size and weight are being increasingly limited in today's world of higher material and transportation costs. Therefore, in response, the strength of structural materials is increased, and so is the likelihood of linear elastic fracture.

Higher strength materials, with their associated higher risk of elastic fracture, are being used for applications other than those usually associated with high strength, such as aerospace structures. Even cannon and other

¹J. G. Kaufman, "Committee E-24 on Fracture Testing: An Overview," ASTM Standardization News, April 1979, pp. 8-34; also see other articles in this publication.

armament components, which traditionally have not been size or weight critical, are now considered so. Most armament is now transported by air, so there is a need to limit weight. In addition, much like the aerospace industry experienced certain critical failures, the Army also experienced a failure which very effectively directed its attention toward fracture. Figure 1 shows the result of that failure, a brittle fragmentation fracture which was clearly elastic-stress-controlled. The cannon, made in the 1960's, was an air-melt steel forging of about 1200 MPa yield strength and $90 \text{ MPa}\cdot\text{m}^{1/2}$ plane-strain fracture toughness (ref 2). Fragmentation failures of this sort have been noted in various structures in which materials are used in too high a strength condition and too low a fracture toughness condition. This is the classic elastic-stress-controlled fracture which can be avoided by using linear elastic fracture mechanics. Figure 2 shows a cannon in which this type of fracture was avoided, even though a very significant overpressure of the cannon occurred during firing. In this case the failure was controlled by a significant amount of plastic deformation as the result of a lower strength material than that used in the first example, about 1100 MPa yield strength, and higher fracture toughness, about $140 \text{ MPa}\cdot\text{m}^{1/2}$. These values are typical of more recent vacuum-processed cannon forgings. The cannon was obviously deformed beyond use, but fragmentation did not occur, so there was much less risk of damage and injury in this failure.

²J. H. Underwood and D. P. Kendall, "Fracture Analysis of Thick-Wall Cylinder Pressure Vessels," Theoretical and Applied Fracture Mechanics, Vol. 2, 1984, pp. 47-58.

The above examples with a cannon graphically illustrate just one of many types of structural components in which attention to linear elastic fracture is needed to control failure due to fast fracture.

CURRENT: ANYTHING CAN BE TESTED

The current state of affairs in elastic-stress-controlled fracture testing is that a great variety of test geometries can be considered. One of two basic fracture test methods is used, E-399-83, Standard Test Method for Plane-Strain Fracture Toughness of Metallic Materials, for relatively thick sections and high strength materials, or E-561-81, Standard Practice for R-Curve Determination, for thinner sections and moderately high strength materials. A variety of specimen geometries is helpful when using these methods to perform fracture analysis because such analysis is, in simple concept, a modeling science. An actual crack growth process in a real structure is modeled in the laboratory using a test specimen which should be as similar as possible to the structure in certain key requirements. The most important requirement is that the specimen material match the material of the structure as closely as possible, and the best match is to cut the specimen directly from the affected area of the structure. Another required match is between the type of loading and orientation of the specimen relative to the structure, such as "bending" stresses in the "long" direction of a structure, as a hypothetical example. A wide variety of test specimen geometries makes it easier to address these and other modeling requirements.

Figures 3 and 4 show sketches of two of the test specimen arrangements used in R-curve testing. The center-cracked panel loaded in tension is used

for general testing, but it is also a close model of many thin-sheet components in aerospace structures which are loaded primarily by membrane tensile stresses. The crack-line loaded specimen in Figure 4 was derived from the rectangular, pin-loaded, compact specimen. It has the advantage of a loading which is closely controlled by the downward displacement of the wedge. This specimen is used for modeling sheet or thin plate components in which the loading is controlled by an imposed displacement in or on the structure. The resulting R-curve crack growth is more stable and less likely to proceed quickly to failure in the specimen, and this provides a proper modeling of a structure with displacement-controlled loading.

Plane-strain fracture toughness tests have been performed in the same basic manner as that of the current test method, E-399-83, for about two decades. Because of this, many different applications and test conditions have been studied, including a variety of test specimen geometries. Three of the geometries now included in E-399-83 are shown in Figure 5. The three-point bend specimen obviously models the simple rectangular beam in bending, which is commonly encountered in all areas of structural analysis. Many structural components are loaded primarily in bending, and tests with this specimen are often the easiest to set up and perform. Figure 5(b) shows a test geometry which was developed primarily for the convenience of those testing one common type of structure, the cylindrical pressure vessel. For piping and closed cylinders which are loaded by internal pressure, this arc tension specimen is convenient, because comparatively little machining is required and the full wall thickness of the pipe or vessel can be used. The

cannons discussed earlier, which are in basic function pressure vessels, are tested in this way. The specimen shown in Figure 5(c) was developed because of the relative ease of obtaining and fabricating the specimen from a large structure. This disk-shaped compact specimen is easily removed from a large plate or girder by hollow drilling and then inexpensively finished by turning operations. The stresses and displacements in the disk-shaped compact specimen are within a few percent of those in its predecessor, the rectangular compact.

It should be clear from Figures 3, 4, and 5, and their discussion, that there is a specimen geometry and established method for linear elastic fracture testing in most situations. If modeling of a given crack growth application is not already possible using an existing test method, one of the methods can probably be modified to match the critical loading and geometry conditions of the application.

FUTURE: TEST METHODS TO COVER COMPLEX FRACTURES

There are certainly many established ways to perform elastic stress-controlled fracture testing. Some have been mentioned here, up to this point. There are also many areas that need attention. Four areas will be briefly discussed below. These areas are now being addressed by ASTM and elsewhere, so that well-defined fracture test methods may become available in the near future.

The surface crack is both a very commonly occurring natural flaw and the classic three-dimensional problem in fracture mechanics. Consider Figure 6

(ref 3), a near-actual-size photo of the fracture surface of a surface-cracked aluminum plate. Some aspects of surface-crack growth are now understood; the stress intensity factor, K , for ideal semielliptical shaped cracks, including the finite-thickness, three-dimensional effects, are known quite accurately. But complex shapes, such as the two-lobed shape in Figure 6 and the situation as the crack intersects the free surface, are still puzzles for nearly all cracked geometries, not just for surface cracks.

Rapid crack growth also has been addressed to some extent and needs more work. A K_{Ic} test method for loading times as fast as one millisecond was recently added to Method E-399. The next significant increase in loading rate for elastic fracture testing will be accomplished by using the crack arrest testing procedure now being developed. For those materials, mostly steels, in which this method can be used, the critical K value at crack arrest will give a good measure of the critical K for a very rapidly running crack.

Simple correlative tests, although not often considered as critical as the "basic" tests such as K_{Ic} , are nonetheless important, because they provide some data where ordinarily none would be available due to cost or other restraints. For example, notched bar impact tests, notably the Charpy test, have been used successfully to provide a workable measure of fracture toughness of steels. A new test geometry and procedure currently under development should greatly simplify fracture testing of many aluminum alloys. A chevron-notched specimen test procedure has been proposed which replaces the

³M. I. Jolles and T. J. Watson, "Observations of the Stable Tearing of Semielliptical Surface Flaws," presented at the Eighteenth National Symposium on Fracture Mechanics, 25-27 June 1985, Boulder, CO.

fatigue precracking of the K_{Ic} procedure with angled side-notches so that a V-shaped cross-section remains. A crack can be started at the tip of the V by using a single application of increasing load, resulting in a significant time and cost saving in performing the test.

Composite materials, for some conditions, can be tested in the same general manner as high strength alloys. Elastic-stress-controlled fracture tests of composite materials can closely parallel, at least as an initial approach, the existing R-curve and K_{Ic} test procedures. Cataloging of the types of composite material and test conditions for which the "homogeneous" approach will work for composites should be undertaken, along with the development of a generally different set of test criteria for consistent fracture toughness results with composites. This will be a difficult job, because of the variety of composite materials. However, with the same pressure toward higher strength composite materials as that present with metals, there will be many situations in which the homogeneous linear elastic fracture test methods developed for metals will give a good description of the type of fracture of composites.

REFERENCES

1. J. G. Kaufman, "Committee E-24 on Fracture Testing: An Overview," ASTM Standardization News, April, 1979, pp. 8-34; also, see other articles in this publication.
2. J. H. Underwood and D. P. Kendall, "Fracture Analysis of Thick-Wall Cylinder Pressure Vessels," Theoretical and Applied Fracture Mechanics, Vol. 1984, pp. 47-58.
3. M. I. Jolles and T. J. Watson, "Observations of the Stable Tearing of Semielliptical Surface Flaws," presented at the Eighteenth National Symposium on Fracture Mechanics, 25-27 June 1985, Boulder, CO.



Figure 1. Elastic-stress-controlled fragmentation failure of a high strength steel cannon due to service loading.



Figure 2. Plastic-deformation-controlled rupture of a high strength steel cannon due to overload.

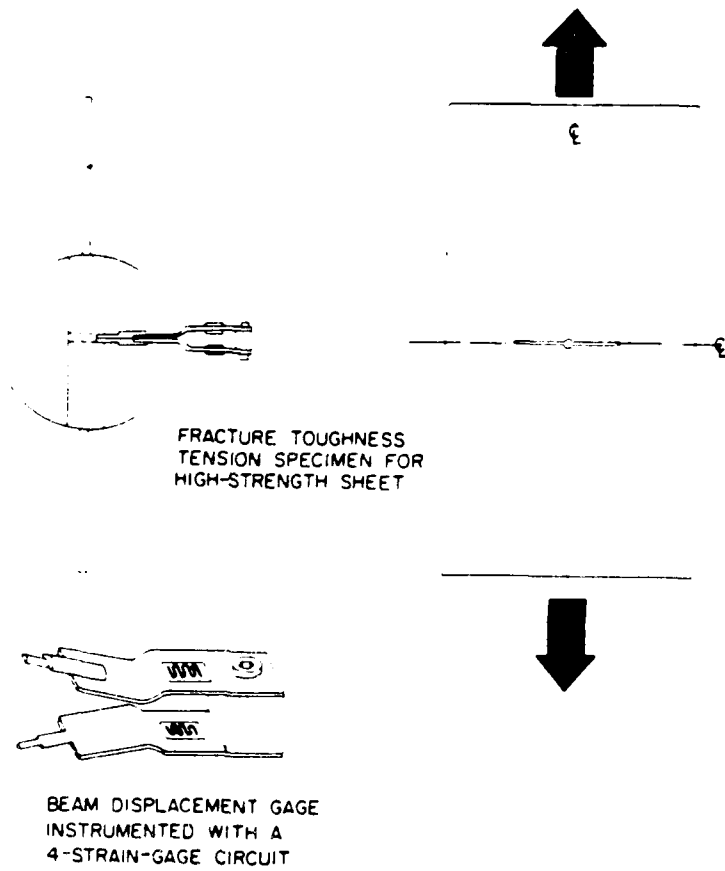

Figure 3. Center-cracked tension panel and displacement gage for R-curve testing.

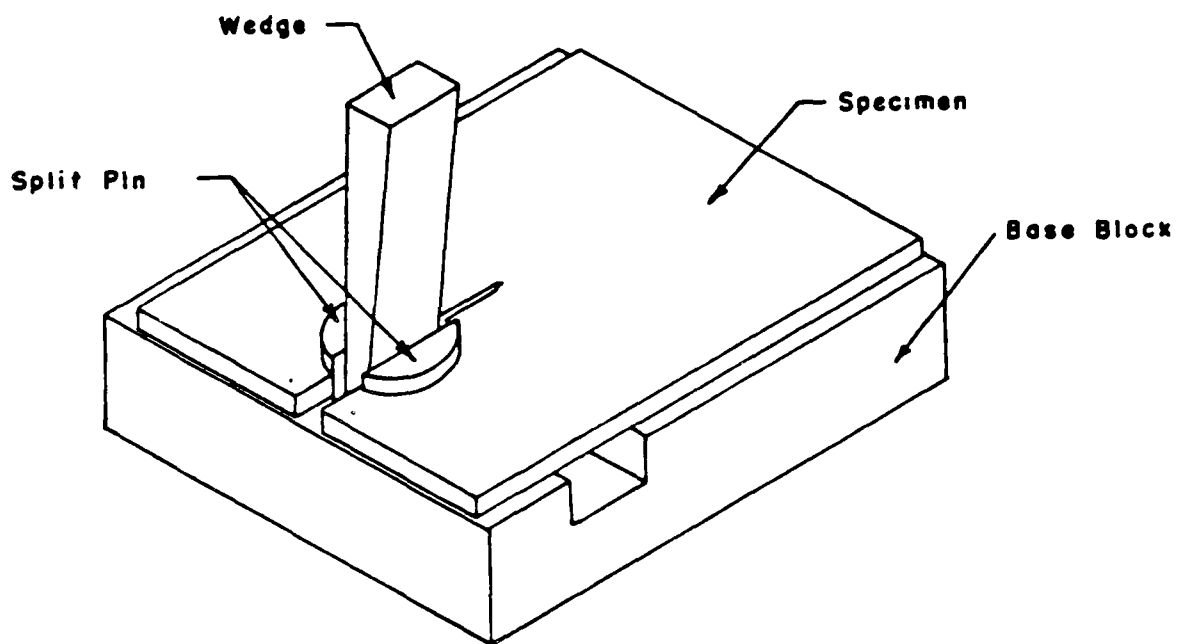
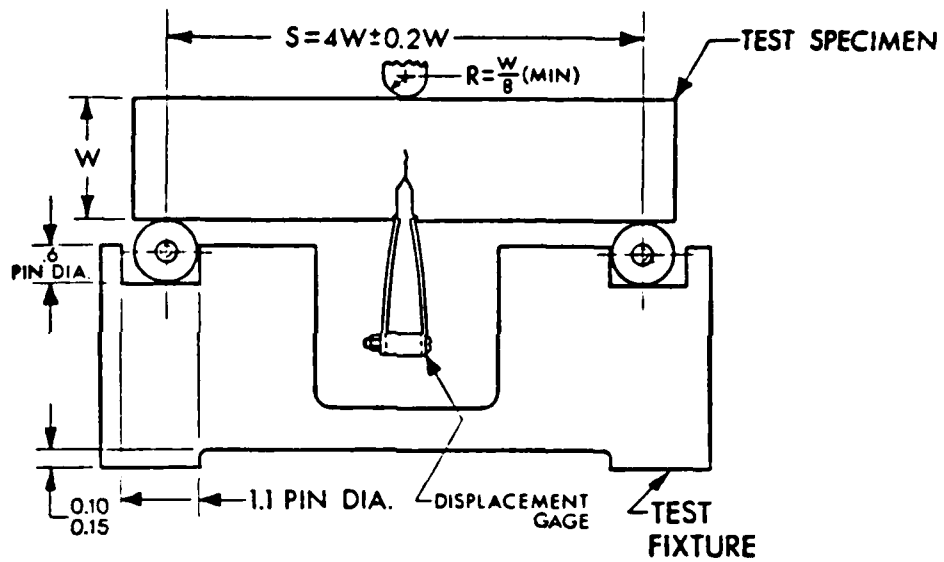
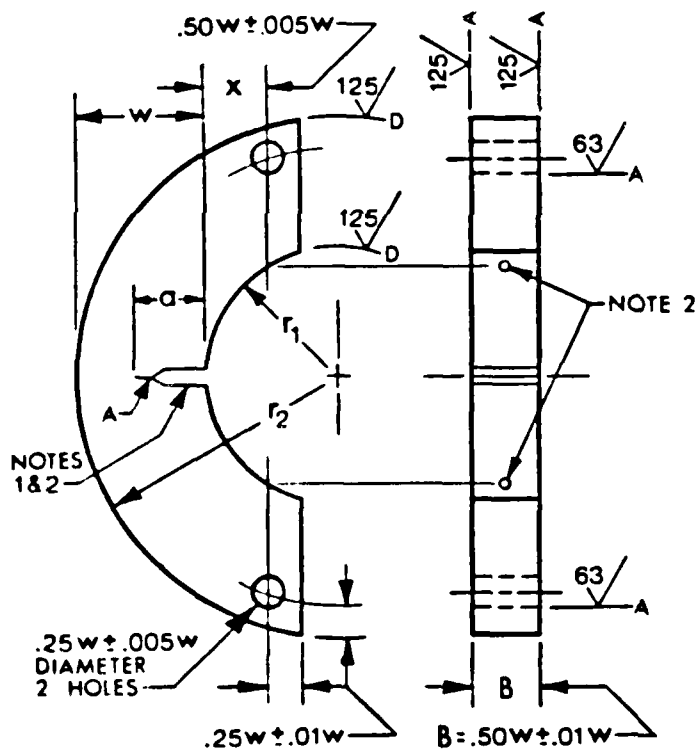

Figure 4. Crack-line loaded compact-type specimen for R-curve testing.



(a) Bend specimen and test arrangement.



(b) Arc tension specimen.

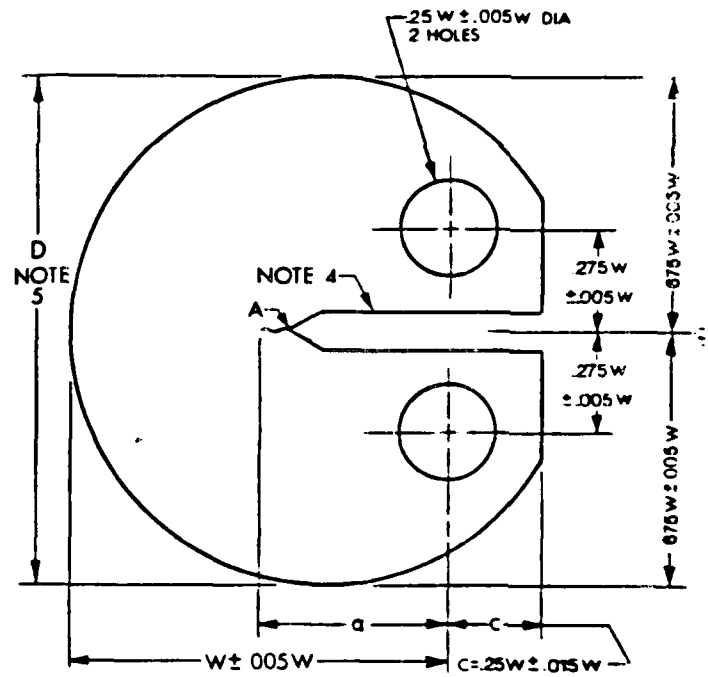

(c) Disk-shaped compact specimen.

Figure 5. Three test specimens for plane-strain fracture toughness, K_{Ic} , testing.

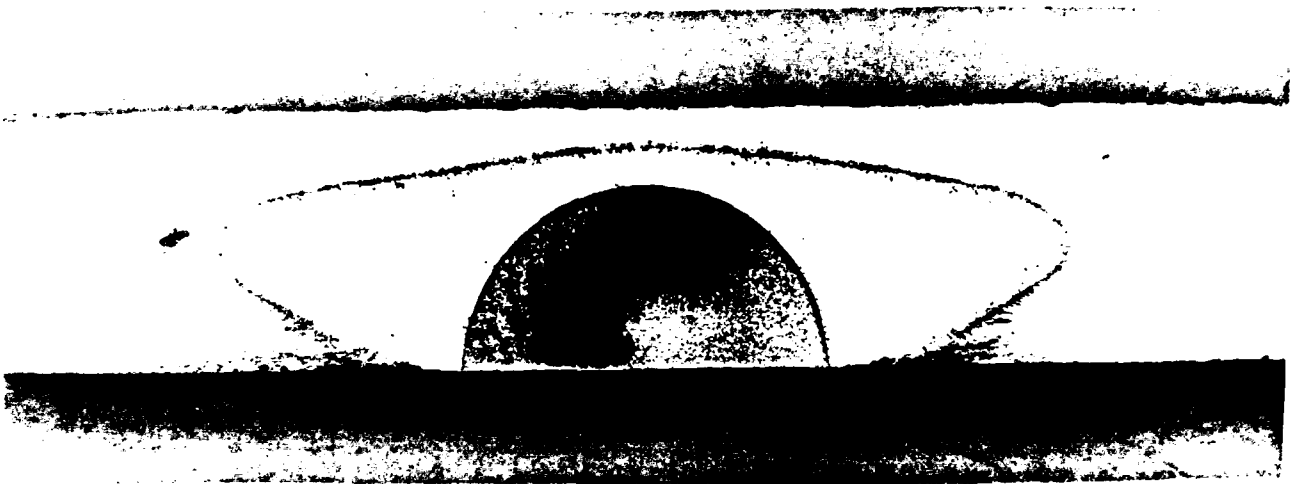

Figure 6. Complex surface crack growth in an aluminum plate: starter notch - semicircular; fatigue cracking - semicircular; stable cracking - complex shape; fatigue cracking - semielliptical; final failure.

TECHNICAL REPORT INTERNAL DISTRIBUTION LIST

	<u>NO. OF COPIES</u>
CHIEF, DEVELOPMENT ENGINEERING BRANCH	
ATTN: SMCAR-CCB-D	1
-DA	1
-DP	1
-DR	1
-DS (SYSTEMS)	1
-DC	1
-DM	1
 CHIEF, ENGINEERING SUPPORT BRANCH	
ATTN: SMCAR-CCB-S	1
-SE	1
 CHIEF, RESEARCH BRANCH	
ATTN: SMCAR-CCB-R	2
-R (ELLEN FOGARTY)	1
-RA	1
-RM	1
-RP	1
-RT	1
 TECHNICAL LIBRARY	5
ATTN: SMCAR-CCB-TL	
 TECHNICAL PUBLICATIONS & EDITING UNIT	2
ATTN: SMCAR-CCB-TL	
 DIRECTOR, OPERATIONS DIRECTORATE	1
 DIRECTOR, PROCUREMENT DIRECTORATE	1
 DIRECTOR, PRODUCT ASSURANCE DIRECTORATE	1

NOTE: PLEASE NOTIFY DIRECTOR, BENET WEAPONS LABORATORY, ATTN: SMCAR-CCB-TL, OF ANY ADDRESS CHANGES.

TECHNICAL REPORT EXTERNAL DISTRIBUTION LIST

	<u>NO. OF COPIES</u>		<u>NO. OF COPIES</u>
ASST SEC OF THE ARMY RESEARCH & DEVELOPMENT ATTN: DEP FOR SCI & TECH THE PENTAGON WASHINGTON, D.C. 20315	1	COMMANDER US ARMY AMCCOM ATTN: SMCAR-ESP-L ROCK ISLAND, IL 61299	1
COMMANDER DEFENSE TECHNICAL INFO CENTER ATTN: DTIC-ODA CAMERON STATION ALEXANDRIA, VA 22314	12	COMMANDER ROCK ISLAND ARSENAL ATTN: SMCRI-ENM (MAT SCI DIV) ROCK ISLAND, IL 61299	1
COMMANDER US ARMY MAT DEV & READ COMD ATTN: DRCDE-SG 5001 EISENHOWER AVE ALEXANDRIA, VA 22333	1	DIRECTOR US ARMY INDUSTRIAL BASE ENG ACTV ATTN: DRXIB-M ROCK ISLAND, IL 61299	1
COMMANDER ARMAMENT RES & DEV CTR US ARMY AMCCOM ATTN: SMCAR-FS SMCAR-FSA SMCAR-FSM SMCAR-FSS SMCAR-AEE SMCAR-AES SMCAR-AET-0 (PLASTECH) SMCAR-MSI (STINFO) DOVER, NJ 07801	1 1 1 1 1 1 1 2	COMMANDER US ARMY TANK-AUTMV R&D COMD ATTN: TECH LIB - DRSTA-TSL WARREN, MI 48090	1
DIRECTOR BALLISTICS RESEARCH LABORATORY ATTN: AMXBR-TSB-S (STINFO) ABERDEEN PROVING GROUND, MD 21005	1	COMMANDER US ARMY TANK-AUTMV COMD ATTN: DRSTA-RC WARREN, MI 48090	1
MATERIEL SYSTEMS ANALYSIS ACTV ATTN: DRXSY-MP ABERDEEN PROVING GROUND, MD 21005	1	COMMANDER US MILITARY ACADEMY ATTN: CHMN, MECH ENGR DEPT WEST POINT, NY 10996	1
		US ARMY MISSILE COMD REDSTONE SCIENTIFIC INFO CTR ATTN: DOCUMENTS SECT, BLDG. 4484 REDSTONE ARSENAL, AL 35898	2
		COMMANDER US ARMY FGN SCIENCE & TECH CTR ATTN: DRXST-SD 220 7TH STREET, N.E. CHARLOTTESVILLE, VA 22901	1

NOTE: PLEASE NOTIFY COMMANDER, ARMAMENT RESEARCH AND DEVELOPMENT CENTER,
US ARMY AMCCOM, ATTN: BENET WEAPONS LABORATORY, SMCAR-CCB-TL,
WATERVLIET, NY 12189-4050, OF ANY ADDRESS CHANGES.

TECHNICAL REPORT EXTERNAL DISTRIBUTION LIST (CONT'D)

	<u>NO. OF COPIES</u>		<u>NO. OF COPIES</u>
COMMANDER US ARMY LABCOM MATERIALS TECHNOLOGY LAB ATTN: SLCMT-IML WATERTOWN, MA 01272	2	DIRECTOR US NAVAL RESEARCH LAB ATTN: DIR, MECH DIV CODE 26-27, (DOC LIB) WASHINGTON, D.C. 20375	1 1
COMMANDER US ARMY RESEARCH OFFICE ATTN: CHIEF, IPO P.O. BOX 12211 RESEARCH TRIANGLE PARK, NC 27709	1	COMMANDER AIR FORCE ARMAMENT LABORATORY ATTN: AFATL/DLJ AFATL/DLJG EGLIN AFB, FL 32542	1 1
COMMANDER US ARMY HARRY DIAMOND LAB ATTN: TECH LIB 2800 POWDER MILL ROAD ADELPHIA, MD 20783	1	METALS & CERAMICS INFO CTR BATTELLE COLUMBUS LAB 505 KING AVENUE COLUMBUS, OH 43201	1
COMMANDER NAVAL SURFACE WEAPONS CTR ATTN: TECHNICAL LIBRARY CODE X212 DAHLGREN, VA 22448	1		

NOTE: PLEASE NOTIFY COMMANDER, ARMAMENT RESEARCH AND DEVELOPMENT CENTER,
 US ARMY AMCCOM, ATTN: BENET WEAPONS LABORATORY, SMCAR-CCB-TL,
 WATERVLIET, NY 12189-4050, OF ANY ADDRESS CHANGES.

END

DTric

8-86