

AD-A169 281

STUDY OF THE STATUS AND POTENTIAL OF HIGH ENERGY BEAM
WELDING IN SHIPYARD CONSTRUCTION(U) AMERICAN WELDING
INST LOUISVILLE TN J C DANKO SEP 85 ANI-CR-85-082
NB84RC45137 F/G 13/8

1/1

UNCLASSIFIED

NL

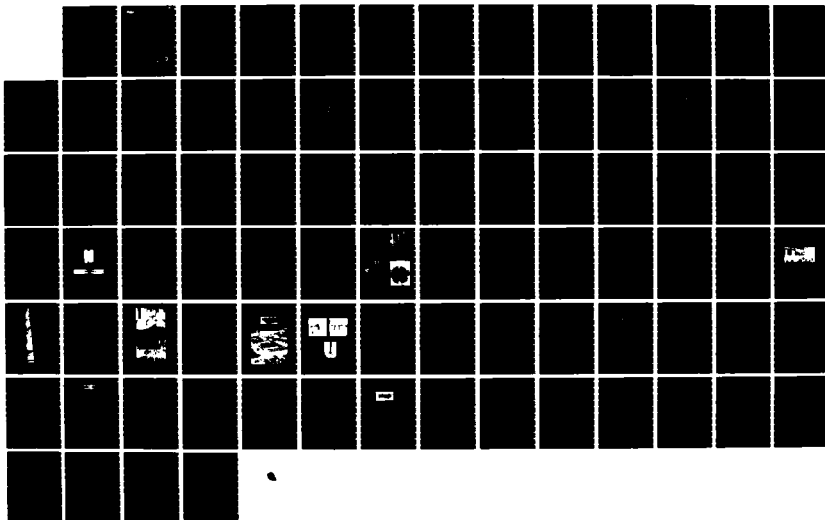

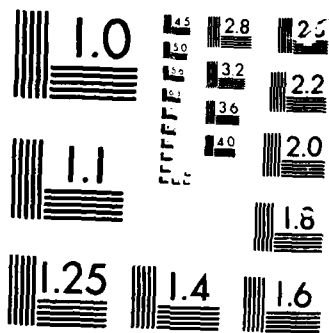



AWI CR-85-002
NBS CONTRACT NB84RAC45137

5

STUDY OF THE STATUS AND POTENTIAL OF HIGH ENERGY BEAM WELDING IN SHIPYARD CONSTRUCTION

SUMMARY REPORT

SEPTEMBER 1985

Contract/Grant N00014-85-G-0251

AD-A169 281

DTIC FILE COPY

DTIC
ELECTE
JUL 01 1986
S D
E

This document has been approved
for public release and sale; its
distribution is unlimited.

AMERICAN WELDING INSTITUTE

86 7 1 058

5

AWI CR-85-002
NBS CONTRACT NB84RAC45137

STUDY OF THE STATUS AND POTENTIAL OF HIGH ENERGY BEAM WELDING IN
SHIPYARD CONSTRUCTION
SUMMARY REPORT
SEPTEMBER 1985

PREPARED FOR
U.S. DEPARTMENT OF COMMERCE
NATIONAL BUREAU OF STANDARDS
325 BROADWAY
BOULDER, COLORADO 80303
CONTRACTING OFFICER'S TECHNICAL REPRESENTATIVE
RICHARD P. REED

PREPARED BY
PRINCIPAL INVESTIGATOR
J. C. DANKO

AMERICAN WELDING INSTITUTE
NEW TOPSIDE ROAD
ROUTE 4, BOX 90
LOUISVILLE, TN 37777

NOTICE

This report was prepared by the American Welding Institute (AWI) for the United States Government. Neither the United States Government, nor any agency thereof, nor any of their employees, nor AWI, members of AWI, nor any person acting on behalf of AWI: (a) makes any warranty, express or implied, with respect to the use of any information, apparatus, method, or process disclosed in this report or that such use may not infringe privately owned rights; or (b) assumes any liabilities with respect to the use of, or for damages resulting from the use of, any information, apparatus, method, or process disclosed in this report.



TABLE OF CONTENTS

	Page
List of Tables	ii
List of Figures	iii
Preface	iv
Abstract	v
Introduction	1
Project Objectives	1
Results of Task 1 - Equipment and Process Review	2
Laser Beam Welding Equipment	3
EB Welding Equipment	15
Metallurgical Considerations and Mechanical Properties	24
Comparison of High Energy Beam Welding Processes	42
Results of Task 2 - Application Survey	44
Shipyards Visits	45
High Energy Beam Weld Fabrication	53
Economic Analysis of High Energy Beam Welding	65
General Comments on High Energy Beam Welding Systems	71
Conclusions and Recommendations	73
References	76

Approved For	
<i>OK</i>	<i>A</i>
	<i>per</i>
<i>A-1</i>	



LIST OF TABLES

1. Worldwide 1984 Industrial Laser Sales for Welding Application
2. Information on Commercial High Power CO₂ Industrial Lasers
3. Information on Commercial Electron Beam Welding Equipment
4. Information on Users of Electron Beam Welding Systems
5. Comparison of Electron Beam and Laser Welding For Shipyard Construction
6. Shipyards Visited
7. Application of High Energy Beam Welding
8. Cost Estimates for Shipyard Fabrication

LIST OF FIGURES

1. Representative Beam Delivery Configuration
2. IITRI Laser Center Facility
3. UTRC 3-Module Industrial CO₂ Laser System
4. Main Elements of the Electron Beam Gun Column
5. Effect of Welding Chamber Pressure on Penetration and Weld Shape
6. Laser Power and Welding Speed Parameters for Different Weld Thicknesses
7. Multipass Laser Weld Configurations
8. Comparison of Burn Times for Laser Beam and Arc Welding Processes
9. Comparison of Heat Input to Weld for Laser Beam and Arc Welding Processes
10. Laser Weld Characteristics in Grade B Ship Steel
11. Macro and Micrographs of 3-3/8-inch A516-70 Material EB Weld in As-Welded Conditions
12. Transverse Bridge Setup for Down Flat Automatic SAW Process for Welding Butt Seams of Panel or Deck Plates
13. Panel Production Line
14. A Typical Hydraulic Holddown Ram Setup with Dual Head SAW of T-stiffener to Panel Fillet Welds
15. Typical Dual Head SAW of T-stiffener to Panel Fillet Welds
16. Todd Pacific Shipyard Web Frame Attachment
17. Typical Welded Pipe Joints at Todd Pacific Shipyard
18. Panel Production Line Utilizing Laser Welds
19. Nonvacuum EB Welding Flat Panel Line Fabrication
20. External EB Setup for Welding Pipe Joints
21. Schematic Presentation of Internal Chamber for EB Pipe Welding
22. Schematic Presentation of Counter Chamber with Special Seals
23. Schematic Drawing of Laser Fillet Welder System for Mounting Stiffeners

PREFACE

This report was prepared in performance of the United States Department of Commerce, National Bureau of Standards, contract NB84RAC45137, Study of the Status and Potential of High Energy Beam Welding in Shipyard Construction. This project was administered through Dr. R. P. Reed, the contracting office technical representative, and Dr. T. A. Siewert of the Fracture and Deformation Division, National Bureau of Standards, Boulder, Colorado.

Work under this contract was subcontracted to United Technologies Research Center for the laser beam welding and to the Chicago Bridge and Iron Company for the electron beam welding. Messrs G. T. Peters and H. C. Ferrell were the project managers for the respective organizations.

Dr. J. C. Danko was the principal investigator for the American Welding Institute.

ABSTRACT

This summary report presents the results of the work performed under the National Bureau of Standards contract NB84RAC45137 on the Study of the Status and Potential of High Energy Beam Welding in Shipyard Construction. The objective of this paper study was to assess the possibilities of achieving higher productivity through development of high energy beam welding processes with the intent to contribute to the reduction-to-practice of specific welding equipment and procedures. Part of this study was performed by United Technologies Research Center on laser beam welding and part by Chicago Bridge and Iron Company on electron beam welding.

SUMMARY REPORT

INTRODUCTION

This first report presents a summary of the work performed under the National Bureau of Standards (NBS) contract NB84RAC45137 on the Study of the Status and Potential of High Energy Beam Welding in Shipyard Construction. The Fracture and Deformation Division of the National Bureau of Standards conducts research related to welding control, effects, and inspection of weld defects. NBS has established a collaborative program with the Welding Research Council and the American Welding Society to study advanced weld processes leading to higher productivity. An early portion of the collaborative program includes the assessment of high energy welding processes, electron beam (EB) and laser, applied to one segment of welding fabrication, the shipbuilding industry.

PROJECT OBJECTIVES

The objective of this study is to assess the possibilities of achieving higher productivity through development of high energy beam welding processes with the intent to contribute to the reduction to practice of specific welding equipment and procedures.

Two tasks are addressed in this study; the task titles and objectives are as follows:

Task 1 - Equipment and Process Review

The objectives of this paper study are to assess present equipment, users of the equipment, determine the suitability for industrial application and review published mechanical property data of weldments fabricated using candidate systems.

Task 2 - Application Survey

Objectives of this task, also a paper study, are to identify specific high payoff ship components for high energy beam welding by shipyard visits and contacts, to identify barriers to the industrial application of current EB and laser welding equipment, and to review current processes that have improved shipbuilding productivity.

The results presented in this report include the work performed by two subcontractors: Chicago Bridge and Iron Company (CB&I) on the EB welding and United Technologies Research Center (UTRC) on laser welding. This summary is divided into two sections, representing the two study tasks.

RESULTS OF TASK 1 - EQUIPMENT AND PROCESS REVIEW

Information covered in this section of the report includes the assessment of high energy beam welding equipment and a review of available mechanical properties of weldments prepared by EB and laser welding.

Assessment of High Energy Beam Welding Equipment

This covers information on industrial laser and EB welding equipment based upon a survey of U.S. and overseas manufacturers, the industrial applications of the welding processes, cost of the units and operating experience.

Laser Beam Welding Equipment - For industrial applications, gas and solid-state lasers are used (1). The gas laser utilizing CO₂ has become a valuable industrial tool for deep penetration welding, cutting, surface hardening, and other material processing applications. On the other hand, solid-state lasers utilizing neodymium glass, yttrium aluminum garnet (YAG) and ruby are widely used for deep penetration hole drilling as well as thin gage material welding and cutting applications.

The output power of industrial lasers ranges from a few watts up to 25 kW. Many laser units are used on production lines and some have accumulated over 80,000 hours of production-type operation (2). Of the 60 different laser models, approximately half of these are of the CO₂ type (3). About 50 percent of the models are reported to be less than 100-W output. Medium and high power lasers are increasing in importance; and there are currently at least 10 models rated above 1 kW.

The worldwide market for industrial lasers experienced significant growth in 1984. Sales of CO₂ lasers in the power output range of 100 watts to 2 kW accounted for approximately 70 percent of the sales. For welding applications, 355 units were sold; this information is presented in Table 1.

TABLE 1
1984 WORLDWIDE INDUSTRIAL LASER SALES FOR WELDING APPLICATION⁽⁴⁾

<u>Laser Type</u>	<u>Output Power</u>	<u>No. Units Sold</u>	<u>Laser Dollar Value (\$10⁶)</u>	<u>System Dollar Value (\$10⁶)</u>
Carbon-Dioxide (CO ₂)	5 kW	7	5.2	9.0
	2 to 5 kW	18	4.7	11.0
	0.1 to 2 kW	90	9.0	21.0
	100 W	100	2.1	5.0
Solid State	100 W	140	10.0	19.0

High power, CO₂ continuous wave (CW) lasers normally operate at a wave length of 10.6 μ m and generate a high intensity optical beam that can be focused into a small diameter spot that produces a power density on

the order of 10⁶ W in². These unique features make the CO₂ laser an attractive device for deep penetration welding of many types of metals commonly used in shipyard fabrication.

The pertinent design features of lasers that should be evaluated for the application of deep penetration welding are briefly reviewed below:

Electric Discharge - Three methods of generating a plasma and maintaining it within the active volume have been used. These electric discharge laser types are: (1) self-sustained, (2) EB sustained, and (3) pulsar sustained. The self-sustained scheme is simple and reliable but does not achieve the output powers of the EB- and pulsar-sustained type. The EB type requires more maintenance, while the PIE (photoinitiated impulse-enhanced) type has complex electrical discharge circuits.

Laser Head Flow Geometric - Most multikilowatt industrial CO₂ laser designs are based upon either an axial flow or transverse flow geometry.

Lasers utilizing axial flow geometrics are limited to power per unit lengths of 60 to 180 W ft and restrict outputs to 6 kW. Transverse flow geometrics produce greater than 300 W ft and facilitate the construction of commercial units up to 20 kW or greater.

Optical System - The optical system of the laser consists of the optical extraction scheme, cavity output window, and beam delivery system. This defines the quality of the laser beam that reaches the workpiece. The beam delivery system should incorporate rigid structures that are very stable to temperature variations and designed to minimize transmission of vibrations and to alleviate steady

mechanical loads. A representative beam delivery configuration is shown in Fig. 1.

Spot diameters on the order of 0.2 to 0.04 in. are usually prevalent for deep penetration welding with multikilowatt lasers. Deep penetration welding requires power densities on the order of 6×10^6 to $20 \times 10^7 \text{ W in}^2$. Desired power densities are realized with the above range of spot size.

Power stability, the ability to maintain the set output power for a sustained period of time, is another important characteristic of the laser system. Power stability is measured on the basis of both short-term (30 minutes or less) and long-term (8 to 10 hours) tests and will range from ± 2 percent to ± 5 percent.

Laser Manufacturers - This survey was performed to identify and characterize CO_2 laser welding systems that would be adaptable to shipyard construction. Laser sources include: (1) original equipment laser manufacturers and laser welding system suppliers and (2) laser material application laboratories. The laser welding system supplier integrates the laser with appropriate beam transport and work handling components to produce a complete welding system. Many of the laser manufacturers have developed a complete system capability and provide turnkey installation of laser beam welding systems.

FIG. 1 - REPRESENTATIVE BEAM DELIVERY CONFIGURATION

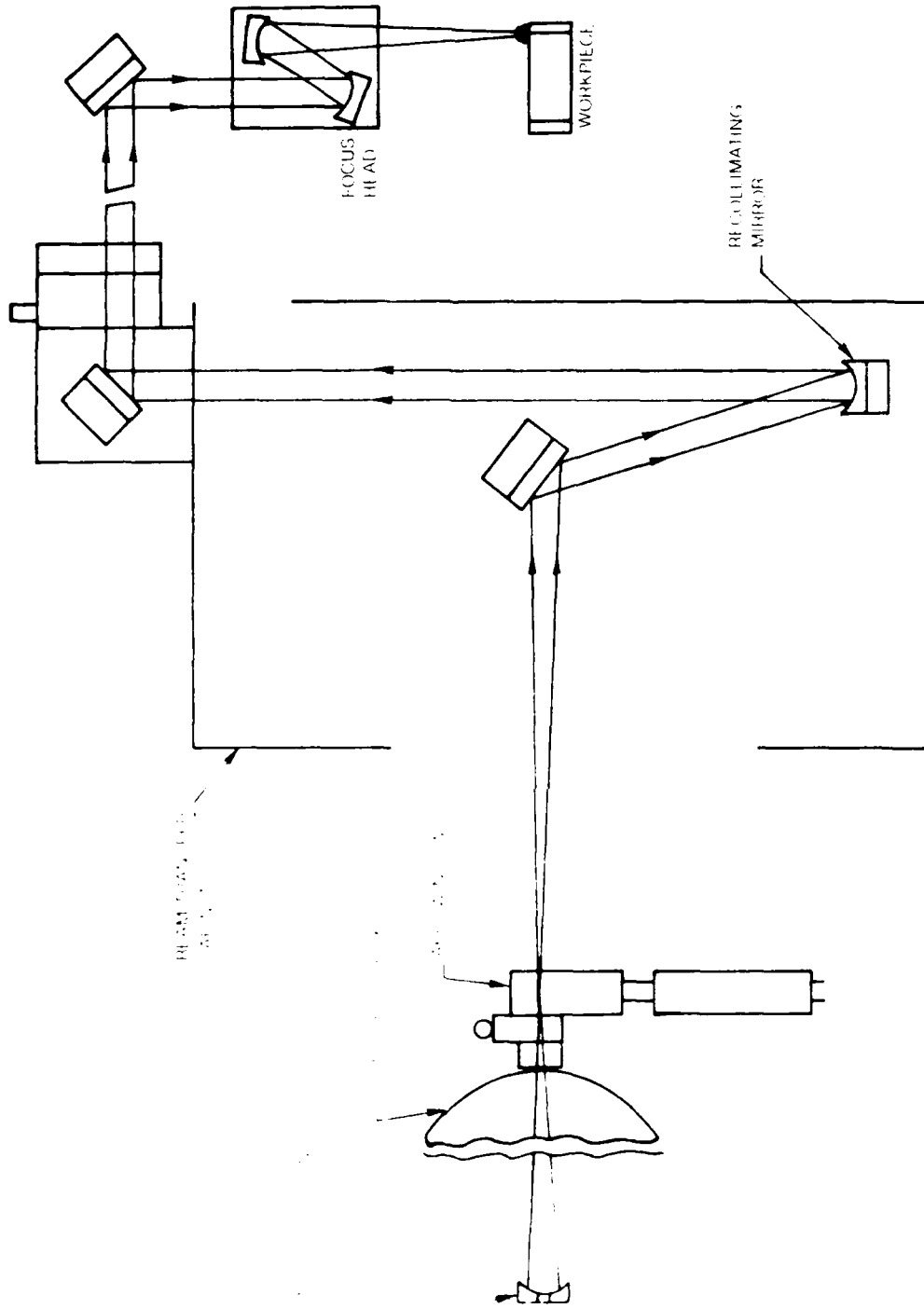

Six United States and ten foreign manufacturers of high power (> 2 kW) CO₂ lasers for welding were identified. Four United States companies, Combustion Engineering, Control Laser, Spectra-Physics, and United Technologies produce CO₂ lasers with output power ratings exceeding 3 kW. Coherent General, Photon Sources, and Spectra-Physics are major suppliers of units with power ratings less than 3 kW.

Foreign manufacturers of industrial lasers that have reached a production ready status include Majestic Laser Systems of Canada, Ferranti Professional Components, Department of Ferranti, Scotland, Leybold-Heraeus of West Germany, and Hitachi, Limited, of Japan. The information on the commercial high power CO₂ industrial lasers suitable for welding is presented in Table 2.

User Operating Experiences with Industrial Laser Beam Welding Systems - Information is presented on the operating experiences of five organizations using multikilowatt CO₂ industrial laser welding systems. It is important to note that none of the five installed laser systems are being operated under a true industrial production line environment. Efforts to obtain this type of operating experience were unsuccessful because most industrial users consider this information proprietary. The only source of this type of information was UTRC; their welding systems have accumulated over 80,000 hours of

TABLE 2
 INFORMATION ON COMMERCIAL HIGH POWER CO₂ INDUSTRIAL LASERS

Manufacturer	Model	Rated Output kW	Operating Range kW	Beam Diameter Unfocused in (CM)	Power Stability %		Efficiency	System Reliability	Unit Cost (\$10 ³)
					Short Term	Long Term			
Coherent General	EFA 53	2.55	up to 3 kW	-	±2	-	-	-	185
Combustion Engineering	HPF 200	20	2 to 20	-	±5	9-10	-	-	1,500
Control Laser	II-3000	3	0.3 to 3	1.2 (3)	±5	-	95	-	-
	II-6000	6	0.4 to 6	1.3 (3)	±5	-	-	-	-
Photon Sources	Turbo- lase	2.5	-	-	±5	-	80	-	175
	I-3000								
Spectra Physics	973	2.5	-	1.7 (4.4)	±5	-	-	-	-
	975	5.0	-	1.7 (4.4)	±5	-	-	-	-
United Technologies Research Center	TM 21	6	-	1 (5)	-	-	90-95	-	-
	TM 31	9	2-11	2 (5)	±3	-	-	-	-
	TM 41	12	-	2 (5)	-	-	-	-	-
Majestic LAS Systems Canada	N/A	20	-	3.5 (9)	-	-	8	-	-
Cilas-Alcatel(France)	CL 4000	3	-	-	-	-	-	80	210
Ferranti DLC(Scotland)	CL 5	5	1 to 5	-	-	-	-	96	420
	CL 10	10	8 to 10	1.8 (4.5)	±3	-	-	-	745
Leybold-Heraeus (Germany)		2	-	-	-	-	-	-	145
		4	-	-	-	-	-	-	290
	066	6	1.5 to 5	1.8 (4.5)	±2	-	-	-	-
Hitachi, Ltd, (Japan)	H/L-2000		-	-	-	-	-	-	-
	CMP	2	-	-	-	-	-	-	-
	H/L-5000		-	-	-	-	-	-	-
	AMP	5	0.3 to 5	2.2 (5.5)	-	-	18	-	420

production line operation and the reliability of the laser in these systems was between 90 and 95 percent (5).

IIT Research Institute (IITRI) - An AVCO HPL 15 laser has been in use in the Laser Center Facility (Fig. 2) since 1977, and the performance and reliability of the system has been good in that only two service calls have been required. Although IITRI is not engaged in industrial-type production operations, some of their contract work has required two shifts per day operation. Beam-on time has been better than 60 percent and system reliability better than 90 percent at 8- to 10-kW power outputs. Maintenance requirements have been limited to the foil in EB discharge that is changed on the average of once a month and the laser cavity and beam delivery optics that are cleaned every two years.

Westinghouse Electric Corporation - Laser welding is performed at two locations. At the Research and Development Center in Pittsburgh, Pennsylvania, a 15-kW AVCO laser system was installed in 1984 for use in cladding and welding applications. There are no production line operations; the unit has operated very well up to the rated 15-kW output power; and the startup time for the system is rapid. At the Laser Center in Sunnyvale, California, an AVCO HPL 200 unit rated at 25 kW, purchased in 1982, is operating in an industrial weld shop. An inhouse improvement program resulted in modifications in the laser cavity that enhanced the performance and reliability of the system and

FIG. 2 - IITRI LASER CENTER FACILITY

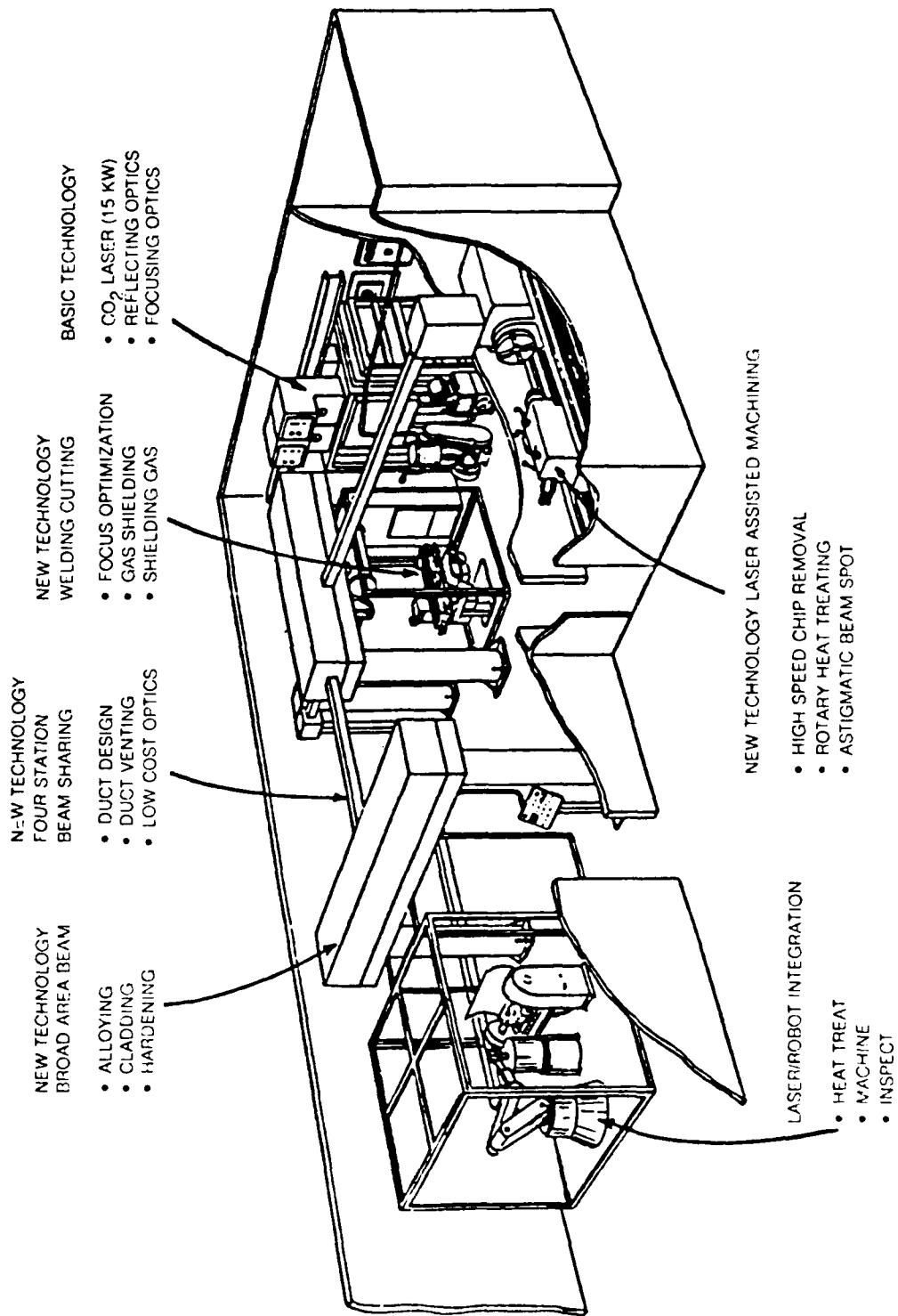

periodic arcing was eliminated. With over two years of operation, the unit has accumulated over 4000 hours of beam-on time at power outputs from 5 to 15 kW. Reliability tests performed in 1984 demonstrated a 90 percent availability based upon an 8-hour shift. The system operated satisfactorily on a 16-hour per day operation for a period of three months with at least 80 percent laser beam-on time. The system is used primarily for development work to define laser material processing techniques and to train personnel in the use of established procedures. Approximately 50 to 70 percent of the system operating time is dedicated to welding applications, and the remainder used for surface hardening studies. Routine maintenance includes changing the electron beam foil every 40 hours of run time and the internal laser cavity mirrors every 2000 hours. The laser bead recirculating blowers are refurbished every 2000 hours.

Naval Research Laboratory (NRL) - A UTRC 15-kW laser system has been used in this facility since 1978 for studies on welding, cladding, heat treatment, and surface hardening. The system is located in a building with an industrial-type environment. For proper operation, the beam delivery system needs protection from the humidity and contaminants in the air. The optics must be free of collected dust to avoid power degradation. NRL has installed a filtered air blower system to protect the beam delivery system. In spite of these problems, the system has provided reliable service and demonstrated an

availability of about 80 percent. Most scheduled maintenance requirements are performed by NRL personnel.

Union Carbide Nuclear Division - A UTRC 9-kW laser beam system (Fig. 3) was installed in 1981 for production line disassembly of fast reactor fuel subassemblies. This system is currently being used for research and development activities. System stability has been good, and no environmentally induced problems have occurred. A total of 280 hours of beam-on time has been accumulated. Normal maintenance involves changing makeup gas supply bottle, checking mirror cooling system, and periodic cleaning of mirrors.

FMC Corporation - The ordinance facility of the Naval Sea Systems Command at Minneapolis is operated by the FMC Corporation and has used an AVCO HAL 200 system since May of 1982. The system is rated at 19 kW at the laser and 15 kW at the workpiece. The unit was purchased to perform welding in an industrial production line environment. To date 3000 hours of total beam-on time, including 32 hours of production beam-on time, have been accumulated. The beam delivery system has maintained good alignment, and no beam wander has been experienced. Powerline disturbances cause the system to shut down. Power stability and beam quality have limited the production line use of the system. Normal operating range for the system has been 6 to 10 kW. System reliability has been a problem with this unit.

FIG 3. - UTRC THREE MODULE INDUSTRIAL CO₂ LASER SYSTEM

MODEL TM 31
OUTPUT RATING. 9kW

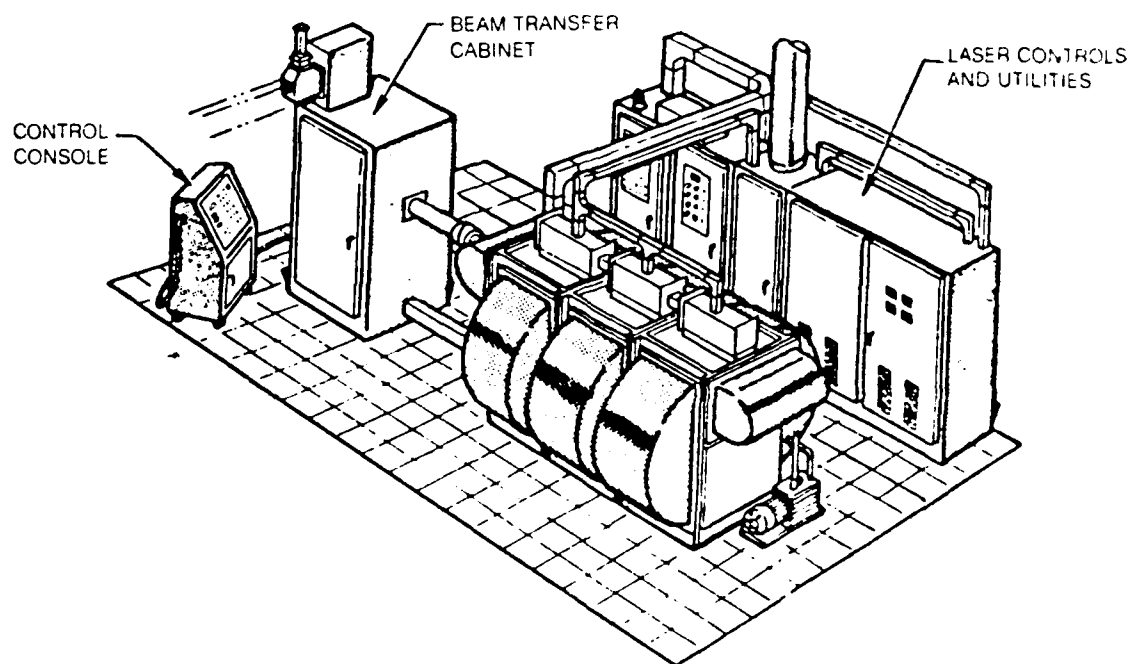

The reported user experience in industrial production line operations is indeed very limited. Nevertheless, sufficient information was presented that demonstrates the capability of multikilowatt CO₂ industrial lasers to operate reliably and efficiently without large maintenance demands in weld shop environments.

EB Welding Equipment - EB welding is a high energy fusion process that is accomplished with a concentrated beam of electrons that have been accelerated to a velocity about 2/3 the speed of light. As the electrons impact the material, they give up their kinetic energy in the form of heat which in turn causes localized vaporization. The reaction force from the vapor produces the presence of a local molten area beneath the vapor. This process continues until the desired depth of the "keyhole" is achieved. The depth of the weld is determined by the power input and the speed at which the beam is moved along the joint. When the beam moves forward, it heats more strongly the leading surface of the cavity; and the molten metal is thrown back behind the beam, exposing a solid surface which in turn is melted and the molten metal passes to the rear and solidifies, thus forming a weld with deep narrow sides.

The beam of electrons is generated in an electron gun by heating a negatively charged emitting material to its thermionic emission temperature range. In this event, free electrons are "boiled off" this emitter and are given speed and direction by their attraction to

a positively charged anode. A precisely contoured electrode surrounding the emitter electrostatically shapes the electrons into a beam.

In a diode (cathode-anode) electron gun, the beam shaping electrode and the emitter are both at the same electrical potential and together are referred to as the cathode.

In a triode (cathode-grid-anode) electron gun, the emitter is at one potential and the beam shaping electrode can be biased to a slightly more negative potential to control the beam current. For this case, the emitter is referred to as the cathode, and the shaping electrode is called the bias electrode or grid cup.

A magnetic focusing lens is used to reduce the diameter of the electron beam and focus the stream of electrons down to the concentrated beam that contacts the work surface. Also, a magnetic deflection coil can be used to "bend" the beam, thus providing a means for moving the focused beam spot to the desired point of contact. The auxiliary mechanical and electrical components in conjunction with the EB gun are commonly called the EB gun column assembly. Fig. 4 illustrates the main elements of the EB gun column.

Depending upon the required capabilities of the electron gun, it can be designed by the manufacturer to achieve various accelerating

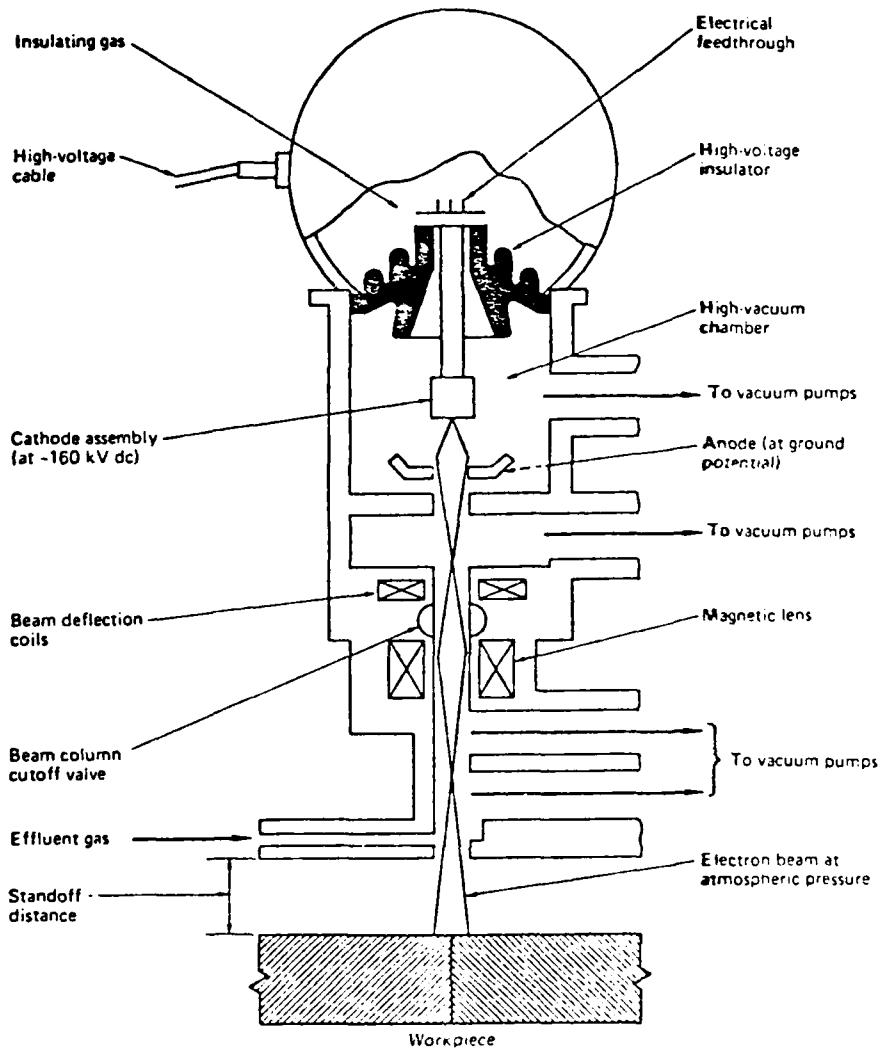

FIG. 4- MAIN ELEMENTS OF THE ELECTRON BEAM GUN COLUMN

voltage levels. If the gun is designed to operate in the 60-kV range, it is considered low voltage. If operation is in the 150-kV range, it is considered high voltage. The main advantage of using an EB gun with high voltage capabilities is the longer gun to work distances possible and the high power spot densities at low beam currents which results in lower emission and longer filament life.

The essential variables which control the weld characteristics are the accelerating voltage (kinetic energy of the electrons), the beam current (number of electrons per second), the travel speed, beam spot size, and the standoff distance between the gun assembly and the workpiece. Increasing the travel speed without changing any other parameters will increase the penetration depth of the beam.

The beam spot size which is focused on the workpiece is determined by the gun and electron optics used, the focusing current, the standoff distance between the gun assembly and the workpiece, the accelerating voltage and the beam current. By changing any of these variables to increase beam spot size will in effect reduce depth of penetration and increase weld width if the welding speed is left unchanged. The normal beam spot diameter used for EB welding varies from 0.005 to 0.050 in., depending upon the power used.

The power density of the EB is in the range of 10^3 to 10^6 W in² which results in deeper penetration and higher welding speeds as compared with conventional welding processes.

The EB gun is normally isolated from the welding chamber through the use of valves. This would allow the gun to be maintained in a vacuum in the order of 1×10^{-4} torr (high vacuum), while the welding chamber can be vented to atmosphere to allow access to the chamber when welding is not taking place. The high level of vacuum on the gun is required to maintain the gun component cleanliness, prevent oxidation, and to prevent arcing between the electrodes at various potentials. It is beneficial to have the welding chamber vacuum at the same degree of vacuum to minimize the scattering of the beam of electrons from collisions with residual air molecules inside the welding chamber during welding.

EB welding can be classified into three distinct modes of welding, depending upon the operating pressure at the workpiece: (1) high vacuum (EBW-HV), where the workpiece is in an ambient pressure ranging from 10^{-6} to 10^{-3} torr; (2) medium vacuum (EBW-MV), where the workpiece is in a vacuum ranging from 10^{-3} to 25 torr; (3) nonvacuum (EBW-NV), where the workpiece is welded at atmospheric pressure in air or in a protective gas coverage such as helium or argon. In all cases, the EB gun must be held at a pressure of 10^{-4} torr or less for stable and efficient operation.

High vacuum and medium vacuum welding are done inside a vacuum chamber. The medium vacuum welding retains most of the advantages of high vacuum welding; but due to the shorter pump downtime (especially in large chambers), capabilities are improved. Performance production tests have shown that relatively narrow EB welds can be completed at chamber pressures of 10^{-2} torr and still be acceptable. If the chamber pressure becomes excessive, the beam scatters and the working distance from the gun has to be decreased significantly to produce a narrow weld. Fig. 5 shows the effect of welding chamber pressure on penetration and weld shape.

The high travel speeds at which EB welding is normally accomplished and the relatively small size of the beam spot requires that the weld seam tracking mechanisms be controlled accurately throughout the weld operation.

Seam tracking is accomplished by scanning the weld seam by either optical, electronic, or X-ray sensing methods.

The optical method uses a low power beam telescopically sighted inside the chamber. This, in conjunction with internal lighting and mirrors, provides a line of sight coaxial with the beam path. The optical method is not very practical for long welding operations due to the metal vapors generated and deposited on the optical surfaces.

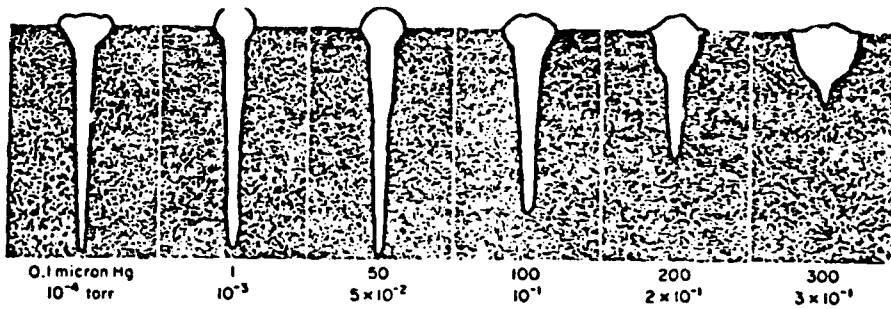

FIG. 5 - EFFECT OF WELDING CHAMBER PRESSURE ON PENETRATION AND WELD SHAPE

The electronic method uses a low-powered beam that scans the weld seam and displays the beam to weld seam relationship on an oscilloscope. The low-powered beam oscillates transversely across the seam at 60 Hz. The amplitude of the oscillation is transmitted back by reflected electrons and the surrounding area of the workpiece on either side of the seam as well as the seam itself is displayed on the oscilloscope.

A recently devised method of seam tracking incorporates the scanning, the correction of the seam deviation, and the welding into a simultaneous operation by the use of a closed loop controller. This is accomplished by the EB determining measurement values by scanning ahead for an extremely short time and with a preselected frequency, recording these values and relaying this information back for the weld contour directly in front of the welding position. Similar to the record and playback method of digitizing the seam, this "real time" tracking method operates on the principle of reflected electrons, using the EB at reduced power as the measuring tool. The beam is deflected transversely across the welding seam of the workpiece. The difference between the electron reflection intensity at the seam and at the adjacent solid material provides the measurement values for the weld seam coordinates.

The X-ray sensor method of seam tracking relies on the periodic high speed scanning of the weld seam ahead of the welding pool by the full power electron beam and sensing the radiation being generated by

the beam impact on the workpiece surface by the means of an X-ray detector. The difference of X-ray emission of the gap and the solid surface creates a signal which can be used for tracking the weld seam. When using filler wire feed systems, this signal can also be used to measure the weld seam gap and directly regulate the wire feed speed to accommodate for variations in the gap width.

EB Manufacturing Survey

Over the last 25 years since EB welding was first introduced on a commercial basis to industry, it has found its niche in many specialized areas of welding. Originally, the EB process was adapted to the nuclear component and aerospace industries where the choice was largely based upon technical reasons associated with material weldability and control of distortion rather than the welding cost; but over the last few years, realization that EB welding is a fast joining process has lead to its use in mass production industries where its speed as well as control of distortion are considered as important factors.

Today, the EB welding process is used on a very wide range of items, including welding wing center sections, pressure vessels, chemical equipment, electrical equipment, etc.

A survey was taken of the domestic electron beam manufacturers and the equipment they produce. The EB manufacturers providing information

were Leybold-Heraeus Vacuum Systems, Sciaky Brothers, and MG Industries - Steigerwald Systems.

Each manufacturer has a complete range of options available from high and low voltage EB guns to small and large chambers. The power rating of the EB guns and the size of the chambers available vary due to the requirements of the material thickness and the component size of the customer purchasing the equipment.

Table 3 presents information on commercial EB welding equipment produced by the three manufacturers. Each manufacturer has the capabilities to design a large chamber system to meet the requirements of the shipbuilding industry. The final cost of the EB system would be dependent upon the options that are required by the individual shipyard.

Several EB equipment users were surveyed, and the data that was collected is presented in Table 4. As seen in this table, the EB systems have common problems related to critical components, such as filaments and electrical components. Nevertheless, the system reliabilities are reported to be very good.

Metallurgical Considerations and Mechanical Properties

The metallurgical characteristics and mechanical properties of laser and EB-welded materials used in shipyard construction are presented in this part of of the report.

TABLE 3
 INFORMATION ON COMMERCIAL ELECTRON BEAM WELDING EQUIPMENT

Manufacturer	EB Models		Output Power kW	System Reliability	Unit Cost (\$10 ³ /kW)	Units Sold	Welding Experience
	High-Vac	Partial Vac					
Leybold-Heraeus	X	X	to 60 kW high and partial vac to 40 kW non-vac	High vac 90-100% 1-2 shifts per day 5-6 days per week partial and non-vac 70-90% operated 2-3 shifts per day 6-7 days per week	400 to 1600	1000	AISI 1018 - 4.75 inches - 30 kW HY 80 - 1 inch - 5.7 kW ASTM A302B- 2 inches - 22 kW 3-4 - 5 inches - 25 kW AA 1100 Al- 5 inches - 25 kW AA 5083 Al- 4 inches - 19.5 kW 6Al-4Vt1 - 5 inches - 30 kW OPHC-Cu - 2 inches - 25 kW
Sociaky Brothers, Inc.	X	X	7.5, 15, 30, 42	75 to 80%	300 to 2000	500	Experience on several grades of carbon steel, stainless steel, aluminum and titanium alloys
MG Industries - Steigerwald Systems	X	X	3, 6, 8, 5, 15, 30, 60	19 hr/day up time	275 to 3000	100(s)	Carbon steel 5 to 50 inches A710 A1, T1 other alloys

TABLE 4

INFORMATION ON USERS OF ELECTRON BEAM WELDING SYSTEMS

<u>Company</u>	<u>Electron Beam Equipment Supplier</u>	<u>kW</u>	<u>No.</u>	<u>Critical Components</u>	<u>System Reliability</u>	<u>Welding Experience</u>
American Saw Co.	MG Industries	8.5	2	Filament (90-100 hrs) electrical components	95 percent up time 2 hrs/week maintenance	High carbon steel
Ridge Tool Co	Leybold-Heraeus	15	1	Computer, electrical components	85 percent up time	carbon steel
McDonald-Douglas	MG Industries	30	1	Filament (40 hrs) vacuum seals electrical components	85 percent up time 3 hrs/week maintenance	2210
Aero Technical Services	Sciaky MG Industries	15 6.5	1 1	Filament, cathode	40 hrs/week 1-2 hrs/week maintenance	Carbon steel, stainless steel, Al, Ti
Grumman Aircraft		30	1 (2 guns)	Filament, anode	50 hrs/week 5 hrs/week maintenance	Ti alloys, Al, SS
Globe Engineering	Sciaky	30	1	Filament, anode electrical components pump seals	30 hrs/week 2 hrs/week maintenance	Mainly SS, some carbon steels
Air Research Co.	Sciaky	18	1	Filament, (4 hrs) anode and cathode annually	95 percent 2-3 hr/week maintenance	Ti, and Al alloys
Kaiser Aerospace	Sciaky	30	1		88-90 hrs/week 15 hrs/week maintenance	Some types of alloys
McCay Tool Engrg Co.	Sciaky	15	1	Filament, (8 hrs) cathode annually	85 percent 2 hrs/week maintenance	All alloys
T. K. International		30	1	Filament, cathode regularly	95 percent 2 hrs/week maintenance	Carbon steel,
EB Associates	Sciaky	30	1	Filament, anode,	40 hrs/week 3-4 hrs/week maintenance	High carbon steels, some stainless
Martin Marietta	Leybold-Heraeus	15	1	Filament, vacuum, door seals	95 percent up time 2 hrs/week maintenance	Carbon steel, low alloy steel, Al

Materials of construction for shipyard applications include: structural alloys of carbon steel such as ASTM A36, high yield strength steels such as HY-80, HY-100, and HY-130, high strength low alloy steels such as ASTM A710, aluminum and titanium alloys for topside super structures, ducting, machinery supports, and pipe materials of low carbon steel, stainless steels (AISI 300 series), aluminum (5000 series), copper and copper nickel alloys.

Because of the high cost of welding, the high yield strength (HY series) steel, the Navy is investigating the use of high strength low alloy (HSLA) steels.

Laser Beam Welding

Extensive laser beam welding investigations of shipyard materials have been performed by private industry and the Naval Research Laboratory. Laser welds in steels up to one inch or more in thickness have been made. Welding with minimal specific energy input results in narrow fusion zones with correspondingly thin heat-affected zones.

Undesirable impurities such as sulfur and phosphorous contribute to laser welding problems. Hot cracking, particularly in quenched and tempered steel alloys, occurs in materials having manganese-to-sulfur ratios appreciably lower than 40:1. Other impurities such as oxides and silicates are sometimes preferentially vaporized from the weld

zone, resulting in weld zone purification and exceptional weld properties.

Although the laser weld pool is relatively small, effective continuous wire feed addition has been demonstrated. This included both cold and hot wire processes. If the quantity of filler material is less than the volume of a bead-on-plate penetration, the bead characteristics are not markedly affected by filler addition. Filler is utilized for desired modification of a fusion zone chemistry as well as to adjust for inadequate joint fitup for an autogenous weld.

A comparison of laser beam and conventional electric arc welding processes was made in order to determine what if any advantages laser welding may have. An empirical model developed at UTRC to correlate high power laser beam welding performance was used to prepare the performance estimates shown in Fig. 6. Data supporting this correlation was obtained from various lasers operating up to 4 kW, 10 kW, 15 kW, and 18 kW (6,7,8,9). Material thickness ranged from 5/64 to 1.5 in. and welding speed varied from 25 to 600 ipm. The data used in the model were restricted to low-alloy steels, the materials of greatest interest for shipyard applications.

The welding performance shown in Fig. 6 can be extended to heavier section material without increasing laser power by the use of multipass welding techniques shown schematically in Fig. 7.

FIG. 6

LASER POWER AND WELDING SPEED PARAMETERS
FOR DIFFERENT WELD THICKNESSES

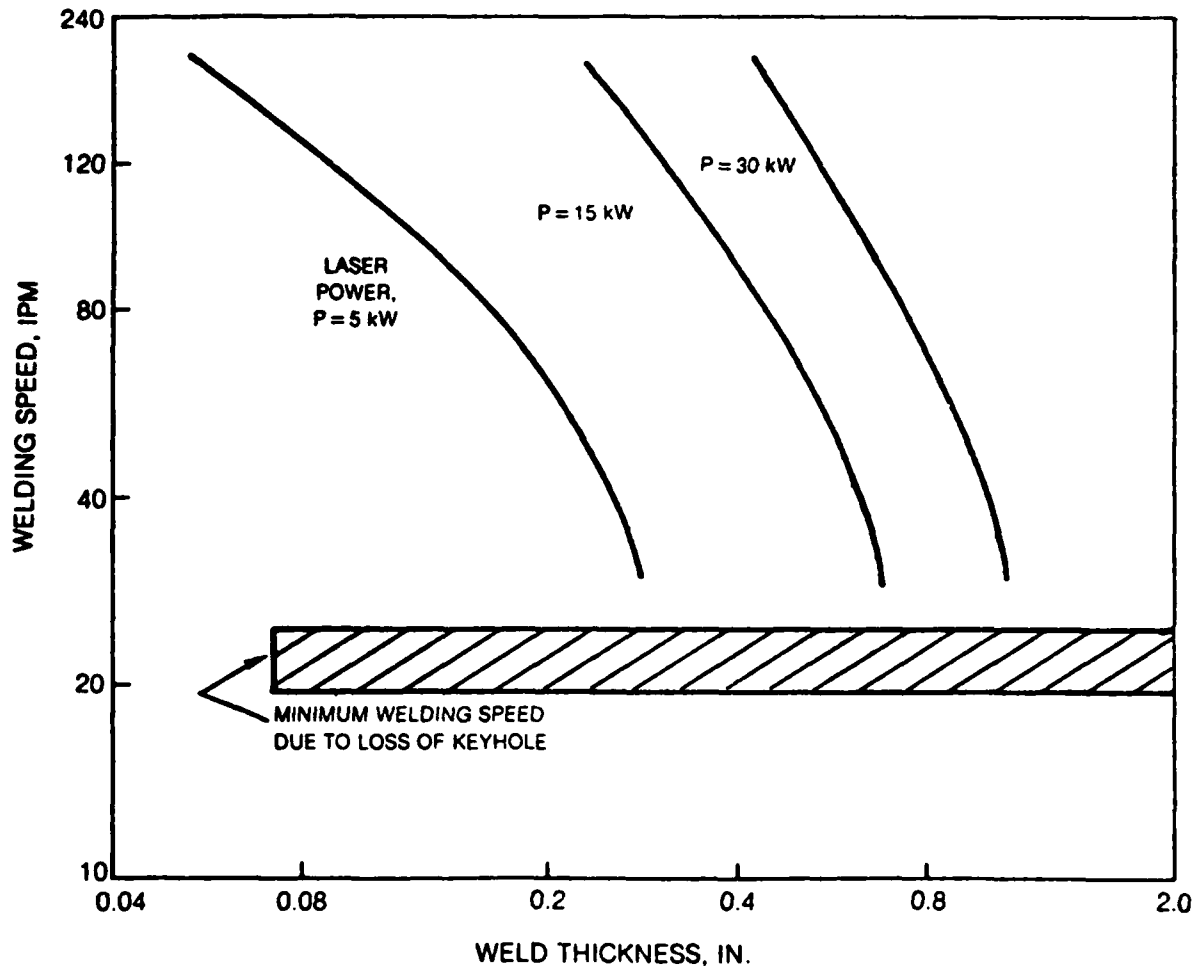
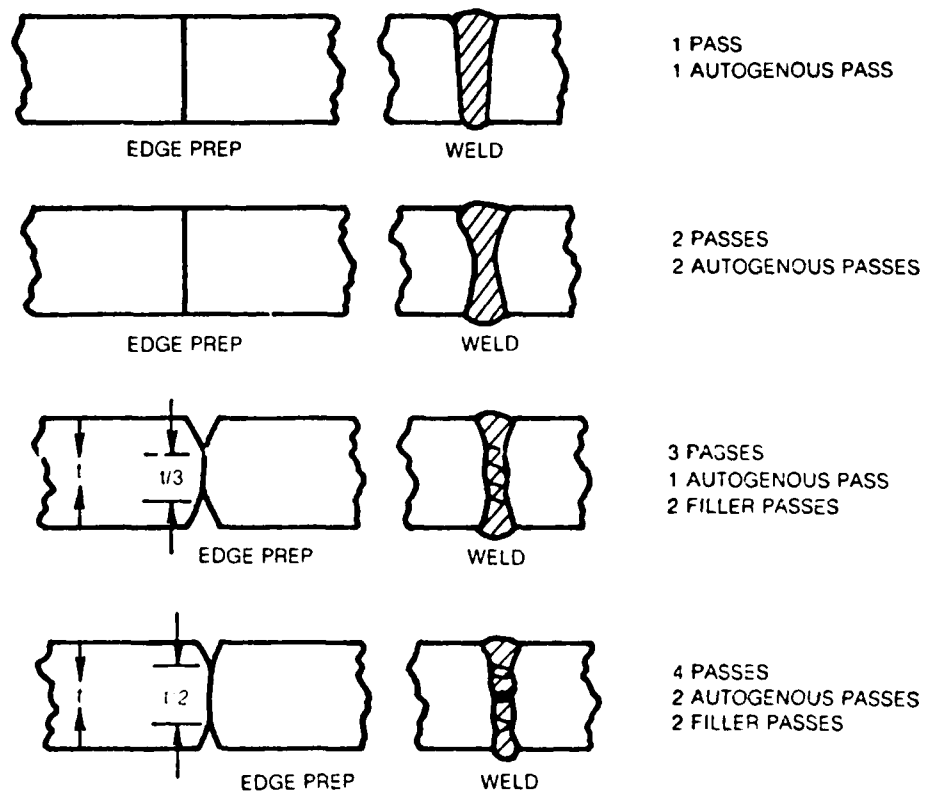

FIG. 7

MULTI-PASS LASER WELD CONFIGURATIONS



Single-pass filler welds of depths up to 0.6 in. have been made with filler wire without serious degradation to the performance shown in Fig. 7. Thus, for multipass welds, it is assumed that each pass of laser beam welding requires the same energy input per unit length as a butt weld of the same thickness as the depth of the pass.

Using this model, a quantitative analysis was performed of laser beam welding performed compared to conventional welding techniques (10).

Welding times for laser beam, submerged arc welding (SAW) and gas metal arc welding-narrow gap (GMAW-NG) are shown in Fig. 8. Arc times for conventional welding techniques assume flat butt welds with prepared grooves (11,12). These welding techniques were chosen for comparison because they have the highest welding speed of conventional techniques. Laser welding speed is a strong function of laser power. For thicknesses appropriate to single-pass laser welding, the 5 kW laser is about 50 percent faster than conventional welding, while a 15-kW laser is 3 to 5 times faster and at 30 kW welding speeds are 5 to 10 times faster than SAW.

Analysis of the heat input to the weld showed that for single-pass and four-pass laser welds, there was a significant reduction in heat input relative to conventional welding processes (Fig. 9). This reduction in thermal energy input to the weld is important in distortion and subsequent straightening operations. However, because of the fast

FIG. 8

COMPARISON OF BURN TIMES FOR LASER BEAM AND ARC WELDING PROCESSES

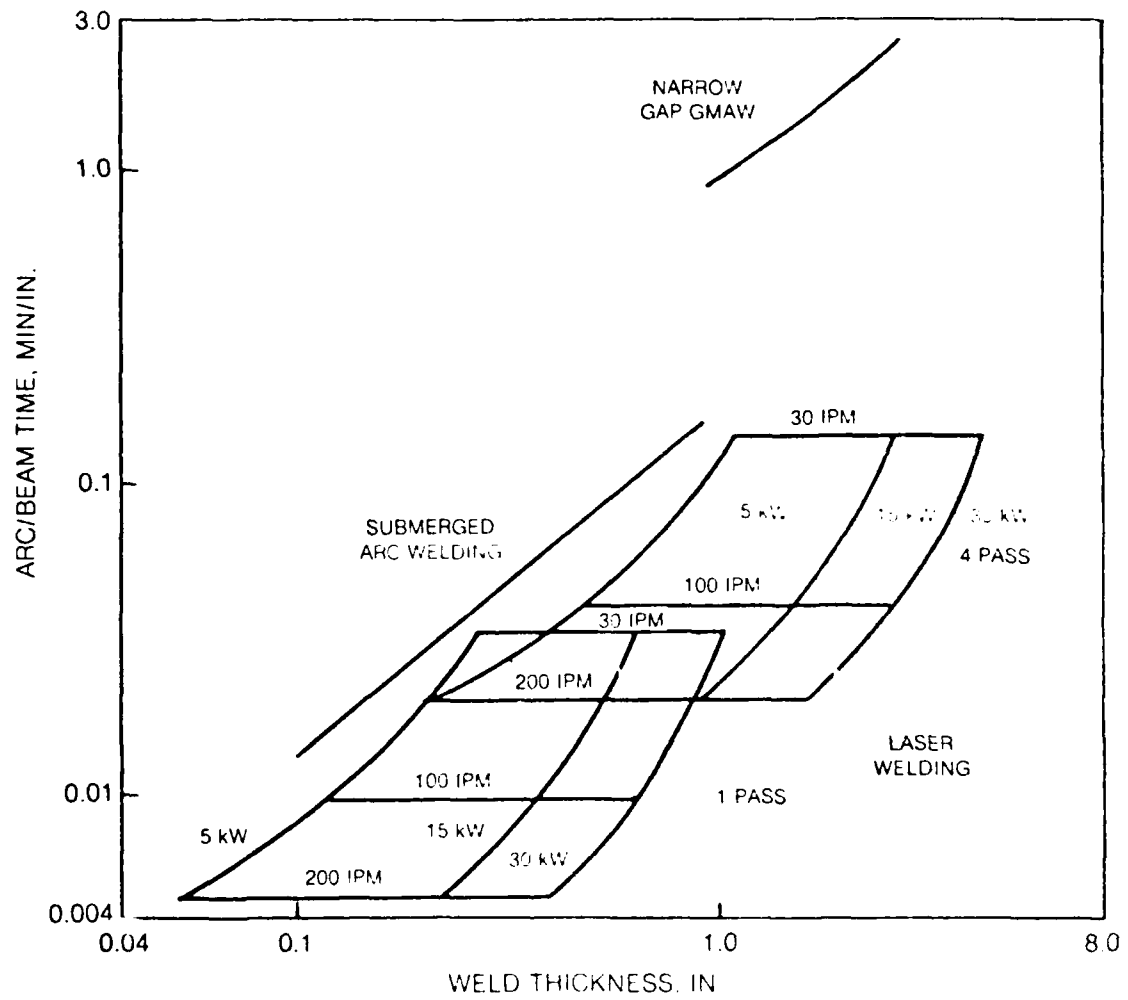
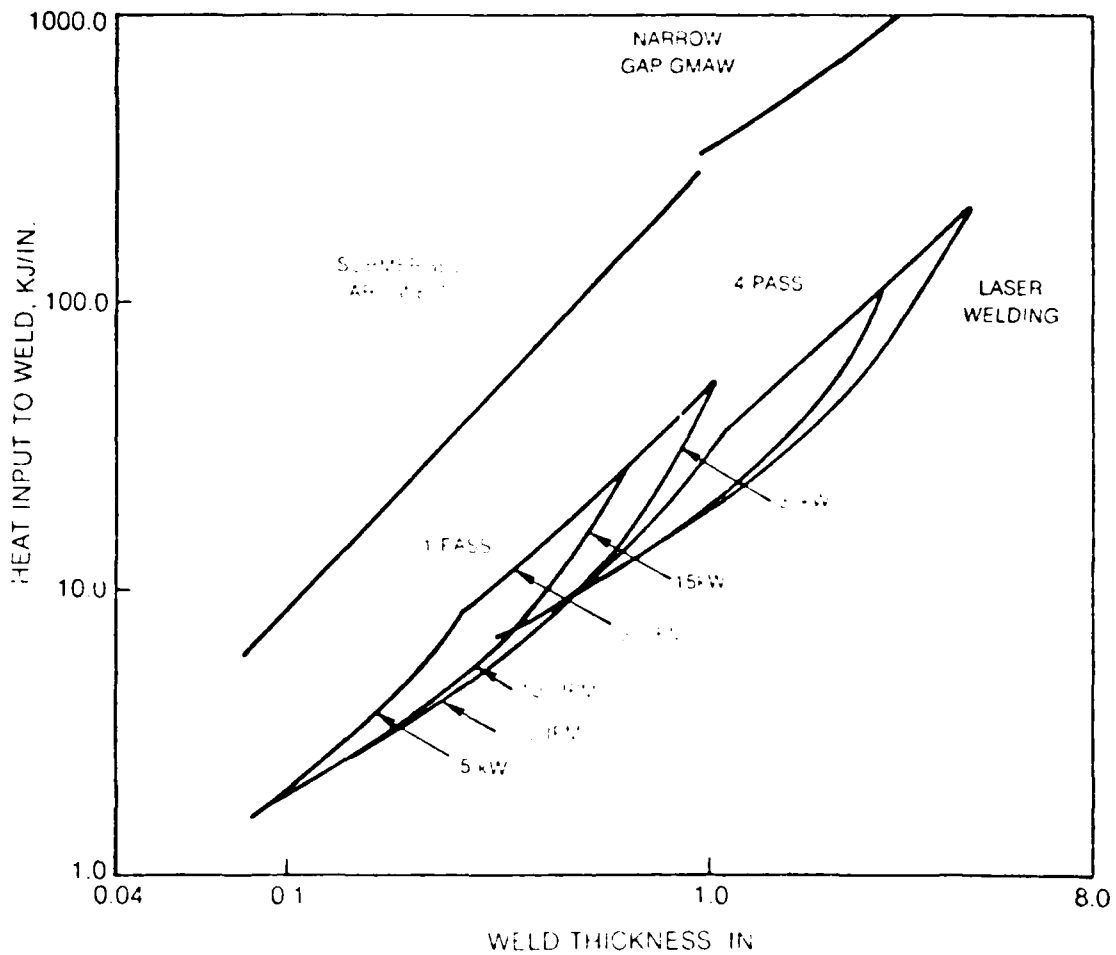

FIG. 9

**COMPARISON OF HEAT INPUT TO WELD FOR
LASER BEAM AND ARC WELDING PROCESSES**



cooling rate, the weld metal may have a tendency to exhibit lower toughness than the HAZ and base metal.

Another advantage of laser welding is the level of weld quality. Results of laser welding of a variety of high strength, low-alloy steels has shown that purification of the metal takes place resulting in fewer nonmetallic impurities in the weld metal than exist in the base metal (13). This phenomenon leads to enhanced toughness of the weld deposit relative to the base metal.

Laser welding of structural grade carbon steels for merchant ship construction was performed on plates ranging in thicknesses from $\frac{3}{8}$ to 1- $\frac{1}{4}$ in. A high power CO₂ laser at power levels of 5.5 to 12.8 kW was used for the autogenous welds. At these power levels, two passes, one pass from each side, was used on $\frac{3}{4}$ - and 1-in. thick material. A cross section of a 1-in. thick plate is shown in Fig. 10. All welds passed X-ray inspection, side bend tests; all tensile tests failed in the base plate and charpy V-notch tests varied and were not consistent between weld metal and heat-affected zone from one weld to another. These properties compared favorably with those obtained from conventional arc welds.

Investigations of laser welding of A36 steel demonstrated the weldability in thicknesses up to $\frac{3}{4}$ in (15,16,17). The mechanical properties were equal to or better than the properties of the base

FIG. 10

LASER WELD CHARACTERISTICS IN GRADE B SHIP STEEL

THICKNESS 1.0 IN
LASER POWER 12.0 kW
WELD SPEED 30 ipm (DUAL PASS)



BEAD CROSS SECTION



SURFACE BEAD



X RAY

metal. Microstructural examination showed a change from the ferrite and pearlite in the base plate to a refined grain size ferrite/pearlite in the heat-affected zone to a bainite in the fusion zone. Hardness traverses were consistent with the microstructural characteristics.

Laser welding of high strength HY-80, HY-100, and HY-130 have been performed and results reported (18,19,20,21,22,23,24).

Satisfactory tensile property values were obtained; however, single pass autogenous welds exhibited poor toughness. Some improvement in toughness properties was achieved with the addition of filler metal and the use of preheat. In welds of HY-80 and HY-100, the use of Inconel 600 inserts resulted in excellent toughness values (25). High hardness values of the heat-affected zones is due to the fast cooling rate inherent in laser welding.

Laser beam welding of the HSLA steels, ASTM A633, A737, A710, and A736 were performed on plates 0.5 in. thick. Autogenous welds and heterogeneous welds using Inconel 600 inserts were prepared. All of the materials were successfully welded. The A633 and A737 weldments exhibited higher tensile strengths than the base metal. A710 and A736 autogenous and heterogeneous welds were slightly lower than base plate properties. Charpy V-notch tests of laser welds of A710 were compared

to those produced by the GMAW process and substantially higher values were obtained from the laser weld.

Defect-free welds have been produced in laser beam welds in titanium and aluminum alloys (26,27).

EB Welding - EB welds are characterized by a narrow parallel-sided fusion zone with a narrow HAZ. The weld usually has low distortion due to the relatively low heat input.

Since EB welds are principally autogenous (i.e., no filler metal), the weld metal microstructure and mechanical properties are mainly determined by the composition of the parent plate and the particular welding parameters chosen. The welding conditions such as the welding speed and the weld width can substantially affect the solidification structure and the resultant mechanical properties of the weld (28).

From several investigations made by Russel et al., it has been shown that acceptable toughness values can be obtained in EB welds although it is sometimes necessary to use preheat or postweld heat treatment (29). This is especially true if the carbon content of the material is relatively high (0.24 w/o). Heat input and cooling rates are also important factors in determining the weld toughness and has been discussed by several different authors. Due to the fast cooling rate, EB weld metal has a tendency to exhibit lower impact strength levels

than the HAZ. It has also been shown that welds with a relatively high width-to-depth ratio have a tendency for cracking, especially if faster travel speeds than normal are used during welding.

A commonly used structural carbon steel used in the shipyard is DH36 (ASTM equivalent A36). EB-welded mechanical property data for these steels, as well as those of other shipyard types of carbon steel such as A575 (M1020), were not available.

CB&I prepared an EB weld of 3-3/8-in. thick plate of SA 516 Grade 70 material and performed mechanical property tests. A square butt autogenous weld was made. Chemical analysis of the base plate and weld metal showed essentially no change in chemistry. Results of four as-welded tensile tests showed failures in the base material. Tests on six guided bend specimens in the as-welded condition were all acceptable. Charpy V-notch tests were made at 0, 20, 60, and 120°F on samples representing the base plate and heat-affected zone and weld metal. All specimens were oriented in direction transverse to the plate rolling direction. The impact properties of the weld metal were poor and well below those of the heat-affected zone and base metal at all test temperatures. At 0 and +20°F, the impact values of the heat-affected zone were between those of the weld metal and base plate. At 60 and 120°F, the heat-affected zone values were essentially in the same range as the base plate.

Microstructural analysis was performed on the A516 weldment. Photomicrographs of the base plate, heat-affected zone, and weld metal are shown in Fig. 11. A photomacrograph of the welded seam is also shown in Fig. 11. The microstructure of the base metal was a pearlite and ferrite structure. The heat-affected zone was a mixture of bainite and martensite, while the weld metal microstructure was mainly martensitic.

Hardness tranverses of the weldment showed variations from the base metal to the weld metal that were consistent with the microstructural variations and mechanical properties.

A search of the literature revealed a dearth of information on electron beam welds of high strength low alloy steels (HSLA). One reference covered evaluation tests performed by Goldak and Bibby on the electron beam welded properties of microalloyed HSLA steels and the results were favorable (30).

In this study, two plates ($1/4$ and $3/4$ -in. thick) of HSLA, A710 Grade A were electron beam welded for mechanical property evaluation. The welds were machined square butt joints and autogenous welded in a vacuum chamber in a horizontal position. The results of the mechanical properties were very similar as those reported for the A516 EB weld.



Base Metal (X100)
(Nital etch)

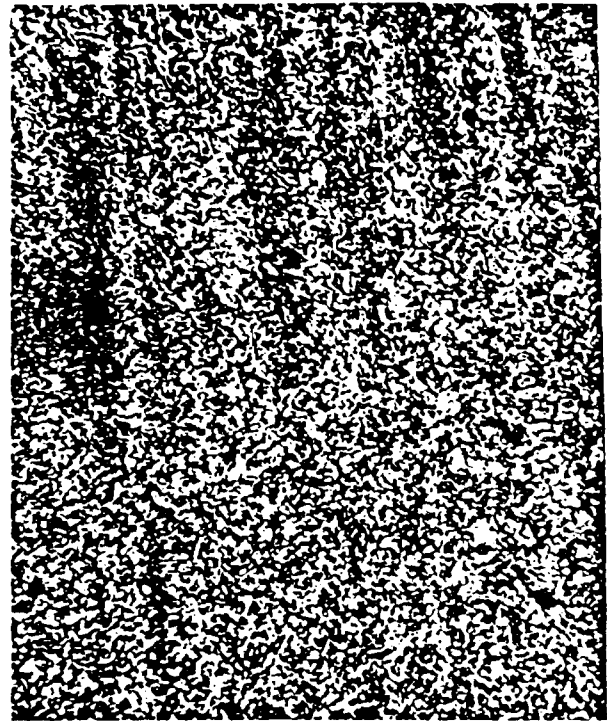

HAZ (X100)
(Nital etch)

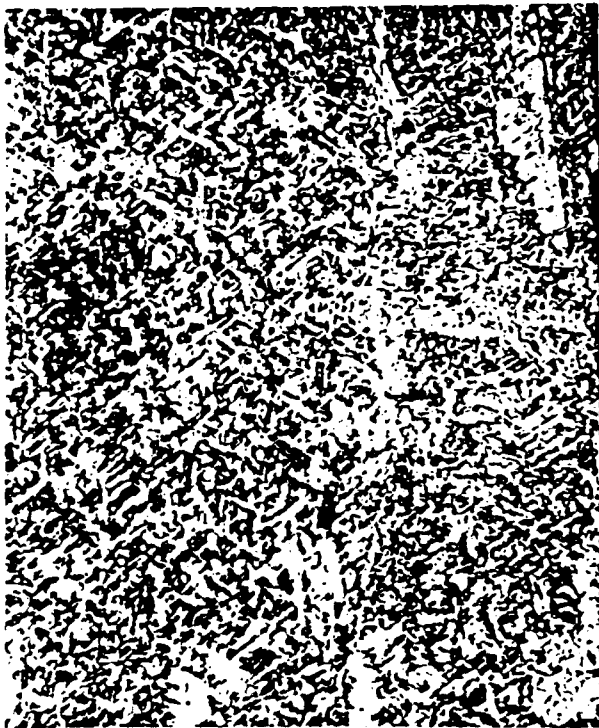

Weld Metal (X100)
(Nital etch)

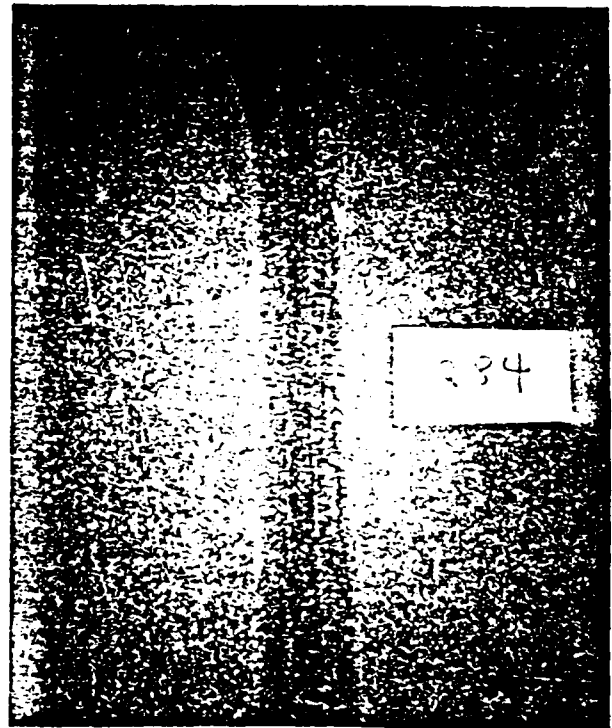

X-Section
(Nital etch)

FIG. 11 - MACRO AND MICROGRAPHS OF 3-3/8" - A516-70
MATERIAL - AS-WELDED

Various development programs have evaluated the EB weldability and mechanical properties of HY-80 material since it is used in the fabrication of steel tees for ships and submarines. Two reports by the David W. Taylor Naval Ship Research and Development Center (DTNSRDC), SME-82/66 and SME-81/47, indicated that HY-80 EB welds had excellent tensile and dynamic fracture resistance properties (31,32). The impact properties were satisfactory if adequate postweld heat treating techniques were used. Occasional low toughness values did occur in the centerline of the weld, but this was associated with the intermittently occurring growth of long parallel martensitic laths at the weld centerline. DTNSRDC stated that the narrow range of welding parameters would require qualification procedures based upon specific welding and heat treatment before EB welding could be implemented for ship construction.

Tests were also performed (EB welded) on 0.85 in. thick HY-100 plate material. The weldments exhibited good tensile properties in the as-welded condition, but relatively low weld metal charpy V-notch impact values (test temperatures of -120°F) were reported. The high as-welded hardness in both the fusion zone and near HAZ were consistent with the relatively poor impact strength for the HY-100 weld in the as-welded condition. The metallography of these structures indicated a predominately martensitic zone.

Tests were performed by Stoop and Metzbowser on EB welds of 1/4- and 1/2-inch HY-130 plate material (33). In the as-welded condition, the weldments exhibited good tensile strengths but relatively low fracture toughness. The weldments demonstrated high hardness values with steep gradients.

Other materials used in shipbuilding industry such as titanium and aluminum are readily weldable by EB in the controlled environment of the vacuum chamber.

Comparison of High Energy Beam Welding Processes

While there are many similarities between the laser and electron beam welding processes, there are also some differences. These are important in selecting the welding process for shipyard construction. An attempt was made to make a direct comparison of these two welding processes, and the results are presented in Table 5.

Both processes offer the advantage of low heat input during welding. This reduces the heat-affected zone and distortion of the weldment. The resultant mechanical properties are equivalent or better than those of comparable arc-welded materials. The rapid cooling of both laser and EB welding will result in low weld metal and heat-affected zone notch toughness in steels with high hardenability such as the HY series and high carbon structural steels.

TABLE 5
COMPARISON OF LASER AND ELECTRON BEAM WELDING FOR SHIPYARD CONSTRUCTION

	<u>Laser Beam</u>	<u>Electron Beam</u>	<u>Remarks</u>
. Commercial Availability	Yes	Yes	A number of suppliers covering a range of power outputs and ancillary equipment.
. Cost	*Very high for both systems - Greater than \$1M for larger units		
. Range of Power Output	To 25 kW	To 100 KW	
. Beam Power Densities	10 ⁶ watts/in. ²	10 ⁶ watts/in. ²	
. Beam Diameter Focused	0.02 to 0.04 in.	0.005 to 0.050 in.	
. Material Thickness	To 1 in. for 25 kW	All thicknesses for vacuum to 1-1/4 inches for nonvacuum	For nonvacuum applications electron beam welding will have a short working distance.
. Operational Environments	Air	Vacuum, soft vacuum, and nonvacuum	Degree of operational problems will depend upon environment.
. Type of Welds	*Autogenous and filler metal additions		Autogenous welds limited to joints with maximum gaps of 3 percent of plate thickness.
. Weld Prep Designs	*Square butt with close gap and mismatch tolerances		This will place close tolerance requirements on the industry.
. Weld Heat Input	Low	Low	Minimizes heat-affected zone.
. Distortion of Welds	*Minimized by low heat input, particularly for thin sections		
. Mechanical Properties	*Equal to or superior to comparable welds produced by arc welding		
. Metallurgical	*High quality welds with minimum heat-affected zone with some improvement in weld metal purity		
. System Reliability	*Very good for both welding systems		Minimum weld repairs.
. Safety Requirements	Primarily high voltage hazards followed by laser beam exposure	X-ray shielding for soft and nonvacuum	Nonvacuum operation of electron beam more difficult.
. Operation Skills	*Trained operators for both systems		
. Application System Information	*State-of-the-art-Systems, primarily for shop fabrication		

*Pertains to both systems

In terms of shipyard applications, the current commercial laser beam welding systems are limited to 25 kW of power, thus the thickness of the material to be welded is limited. While the EB welding system in hard or soft vacuums do not have the limitation (100 kW units are commercially available), nonvacuum applications are very much limited to material thicknesses similar to laser welding.

The high cost of both laser and electron beam welding systems are important considerations and it may indeed be a limiting factor in the application. Further, the utility of both welding systems, while meeting demands of shop fabrication, do not readily lend themselves to field application.

RESULTS OF TASK 2 - APPLICATION SURVEY

This section of the report presents the results of shipyard visits and contacts to identify potential areas of shipyard construction for high energy beam welding and to perform an economic analysis of those areas selected for the application of laser and/or EB welding processes.

The shipyards visited for the laser and electron beam welding surveys are presented in Table 6. As shown in this table, the visit covered completely different shipyards for the two surveys. In this section of the report, the conventional weld fabrication methods and the

potential areas for the application of high energy beam welding are described.

TABLE 6
SHIPYARDS VISITED

<u>Shipyard</u>	<u>UTRC Laser</u>	<u>CB&I Electron Beam</u>
Todd Pacific, Los Angeles, CA	X	
Bath Iron Works, Bath, ME	X	
Electric Boat, Quonset Point, RI	X	
Ingall, Pascagoula, MS		X
Newport News, VA		X
Norfolk, Norfolk, VA		X

Conventional Weld Fabrication

Panel Fabrication - Panels are fabricated from structural carbon steel (A36) 50-60 UTS, high strength steel (HY 80-100) 80-100 UTS and low alloy high strength steels (A710 Grade A). The panel material used depends upon the design and application in the ship hull fabrication. Plate thicknesses range from 3/16 to 7/8 in.

Panel preparation consists of plate descaling and beveling of the plate edges using conventional burning techniques. The panel plates are normally 10 by 25 ft. with fitup using electromagnetic holddown devices for the length of the plate to form assemblies 50 by 50 ft. Seams are tack welded at one station; at a second station longitudinal and transverse seams were welded with the down flat automatic submerged arc welding processes from two separate traveling bridges

(Fig. 12). Panel plate edges $5/8$ -in. thick or less were square butt prep. Plates $5/8$ -in. edge thickness had 45° included bevel prep. Panels were welded from one side turned over and back side of weld seams SAW.

For aircraft carriers, the panel and deck plates were $1/2$ to 2 in. thick. Subassemblies consisted of 4 plates 10 by 40 ft., resulting in 40- by 40-ft. plate assembly. The edge prep usually is of a double bevel design that is shaped by oxy-fuel burning system. Variations in panel plate gap appeared to be between a tight fit to about $1/8$ in. HY-80 and A710 materials are used for carrier panel/deck assemblies.

In one shipyard panel, fabrication lines were outdoors, while at another it was completely enclosed because of the difference in weather conditions. A sketch of panel production line is shown in Fig. 13. The equipment is designed to accommodate 2-sided panel welding and include stations for fillet welding, stiffeners, webs, and bulkheads to the panel.

Many of the shipyards are investigating 1-sided, single pass, SAW that is capable of welding $3/4$ -in. panels in a single pass at high speeds. This also reduces the heat input considerably compared to 2-sided SAW process. Single arc SAW is used for plates with thicknesses equal or less than $1/2$ in. and a twin arc for thick sections.

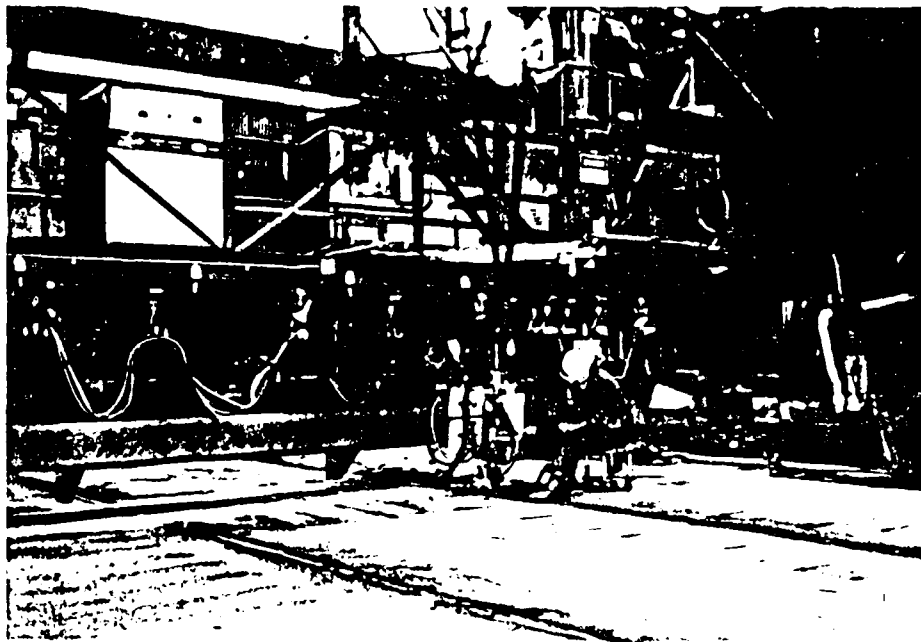
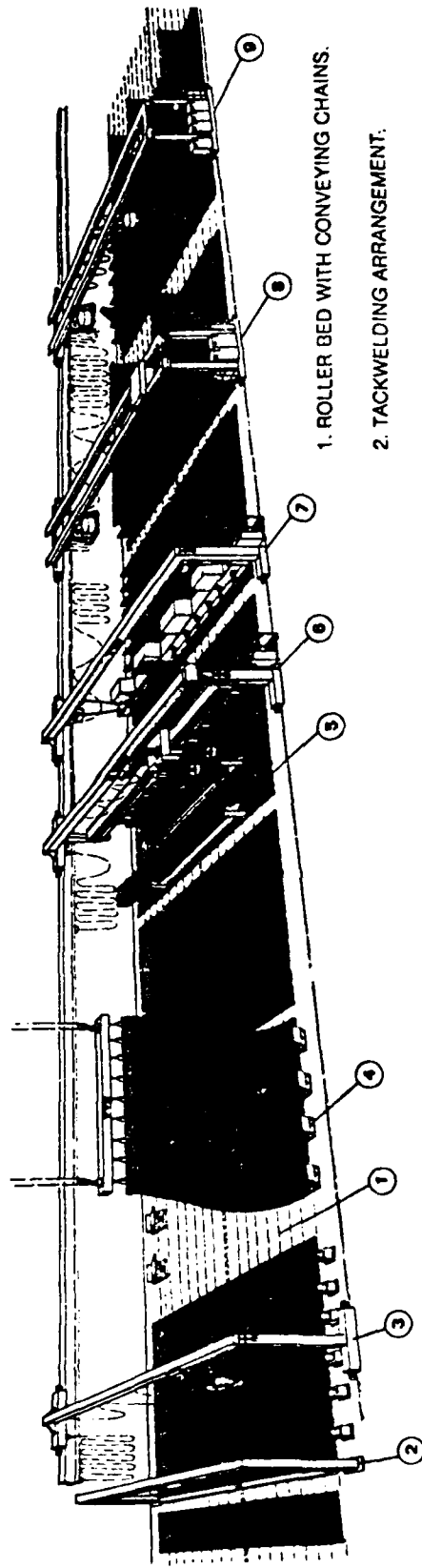

FIG. 12 - A TYPICAL TRANSVERSING BRIDGE SET-UP
WITH DOWNFLAT AUTOMATIC SUBMERGED ARC
PROCESS WELDING BUTT SEAMS OF PANEL
OR DECK PLATES IN SHIPYARD

FIG. 13 - TTS PANEL PRODUCTION LINE



1. ROLLER BED WITH CONVEYING CHAINS.

2. TACKWELDING ARRANGEMENT.

3. BUTTWELDING SERVICE GANTRY.

4. PANEL TURNOVER ARRANGEMENT.

5. STIFFENER PALLET.

6. MOBILE STIFFENER GANTRY "MSG".

7. FILLET WELDING GANTRY "FWG".

8. MOBILE WEB GANTRY "MWG"

9. MOBILE WEB WELDING GANTRY

Panel-Stiffener Fabrication - After panel assemblies were welded, they were moved to the fabrication area where longitudinal and transverse T-stiffeners were fillet welded to the panel sections with semiautomated FCAW (flux core arc welding) process. For the fitup, mechanical and hydraulic devices were used (Fig. 14). In another shipyard, the longitudinal T-stiffeners were welded by a dead head SAW fillet weld on each side of the T. (Fig. 15).

Fillet welding T-stiffeners to a panel is performed with fully automatic, twin-fillet, single-arc welders using FCAW. Magnets press the panel tightly to the stiffeners providing tight fitup for the initial welding operation.

Military standards stipulate a maximum continuous fillet by size of $\frac{1}{8}$ in.; this is required since full penetration welds are not assured. However, leg size must not exceed $\frac{1}{8}$ in.; this requirement is imposed to control ship weight. Fitup tolerances are also controlled by the standards that permit gaps up to $\frac{1}{4}$ in. between plates, the maximum allowable gap cannot exceed half the plate thickness. The maximum gap between butting plate edges is not allowed to exceed half the plate thickness.

Fitup tolerances for welding stiffeners to panels permit a maximum allowable gap of $\frac{1}{16}$ in. This is not a problem with magnetic fitup devices that result in essentially a zero gap. A larger problem is

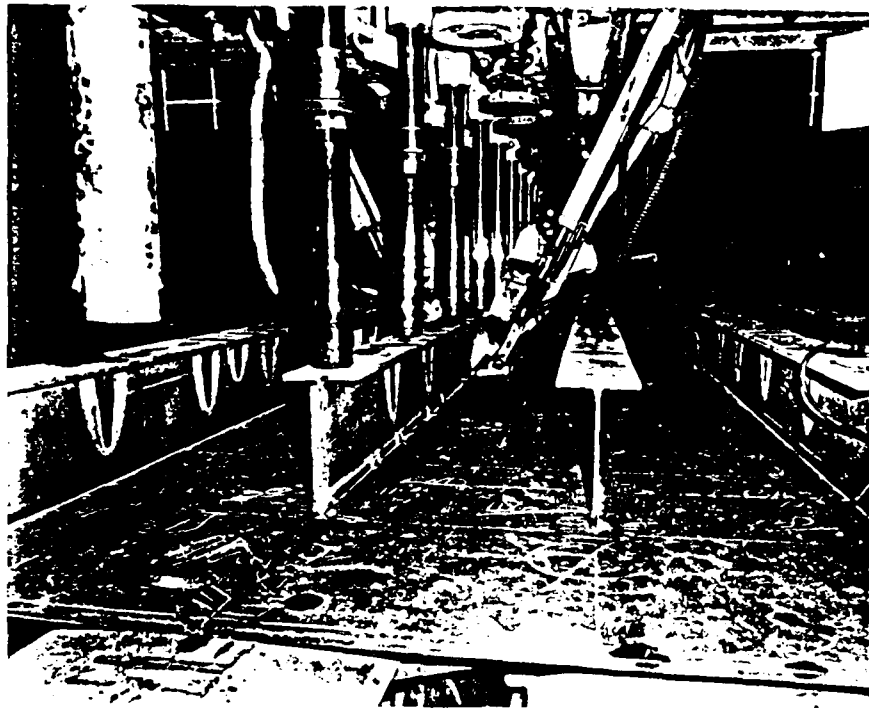

FIG. 14 - A TYPICAL HYDRAULIC HOLDDOWN RAM SET-UP WITH DUAL HEAD SUBMERGED ARC WELDING OF T-STIFFENER TO PANEL FILLET WELDS

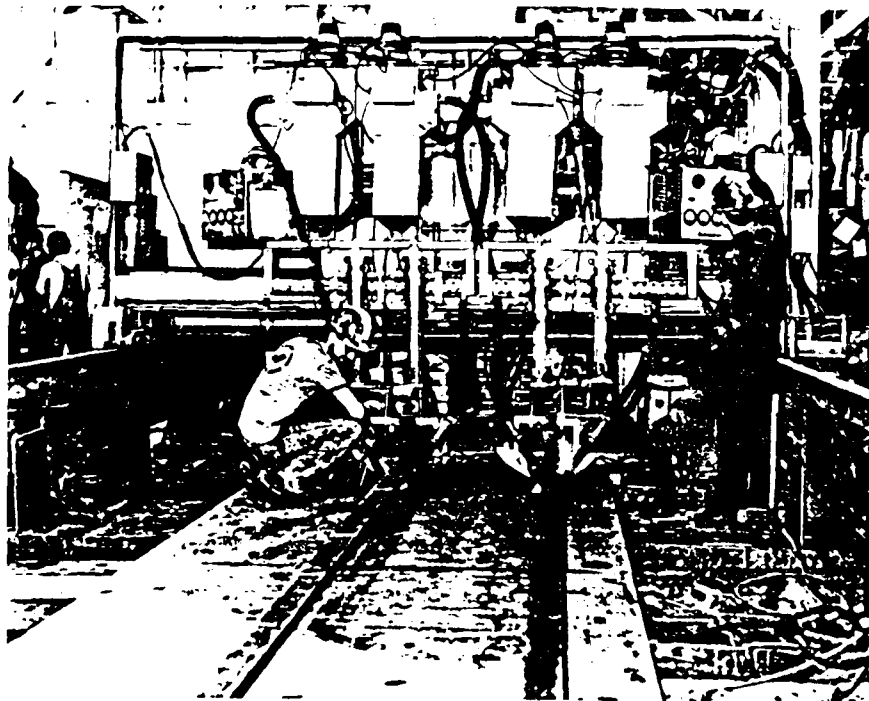

FIG. 15 - TYPICAL DUAL HEAD SUBMERGED ARC WELDING OF T-STIFFENER TO PANEL FILLET WELDS

thermal distortion, particularly in thin (1/2 in.) panels resulting from the weld heat input and subsequent weld metal shrinkage. For example, a stiffener with 3/16-in. web welded to a 1/2-in. panel must not have a distortion greater than 3 degrees from the vertical. Conversely, a distortion greater than 8 degrees is not permitted in the panel. Distortion in panels was found to be a serious problem, particularly in stiffened panels with thickness less than 1/2 in. An example of thermal distortion is shown in Fig. 16. Large presses up to 500 tons are used to straighten the subassemblies.

Pipe Welding - For 2- to 16-in. diameter pipes, most of the welding was performed with pulsed gas metal or flux cored arc welding (FCAW). Small diameter pipes were welded with the gas tungsten arc welding (GTAW) process.

Pipe shops at the three shipyards were similar in layout and operating procedures. Materials include Cu, CuNi, Al, carbon steel, and stainless steel. About 80-85 percent of piping material in one shipyard was Cu or Cu-Ni with larger pipes being Cu-Ni. Pipe diameters range from 1 to 16 in. with thickness ranging from schedule 5 to 80. Pipe edges are manually machined to assure good fitup. Mismatch between joining pipes may be as great as 1/6 in. GTAW and GMAW are normally used. Typical pipe welds are shown in Fig. 17. Orbital pipe welding units (GTAW) are used in some shipyards, while in others the pipe is rotated with a 1G position weld.

FIG. 16

TODD PACIFIC SHIPYARD WEB FRAME
ATTACHMENT

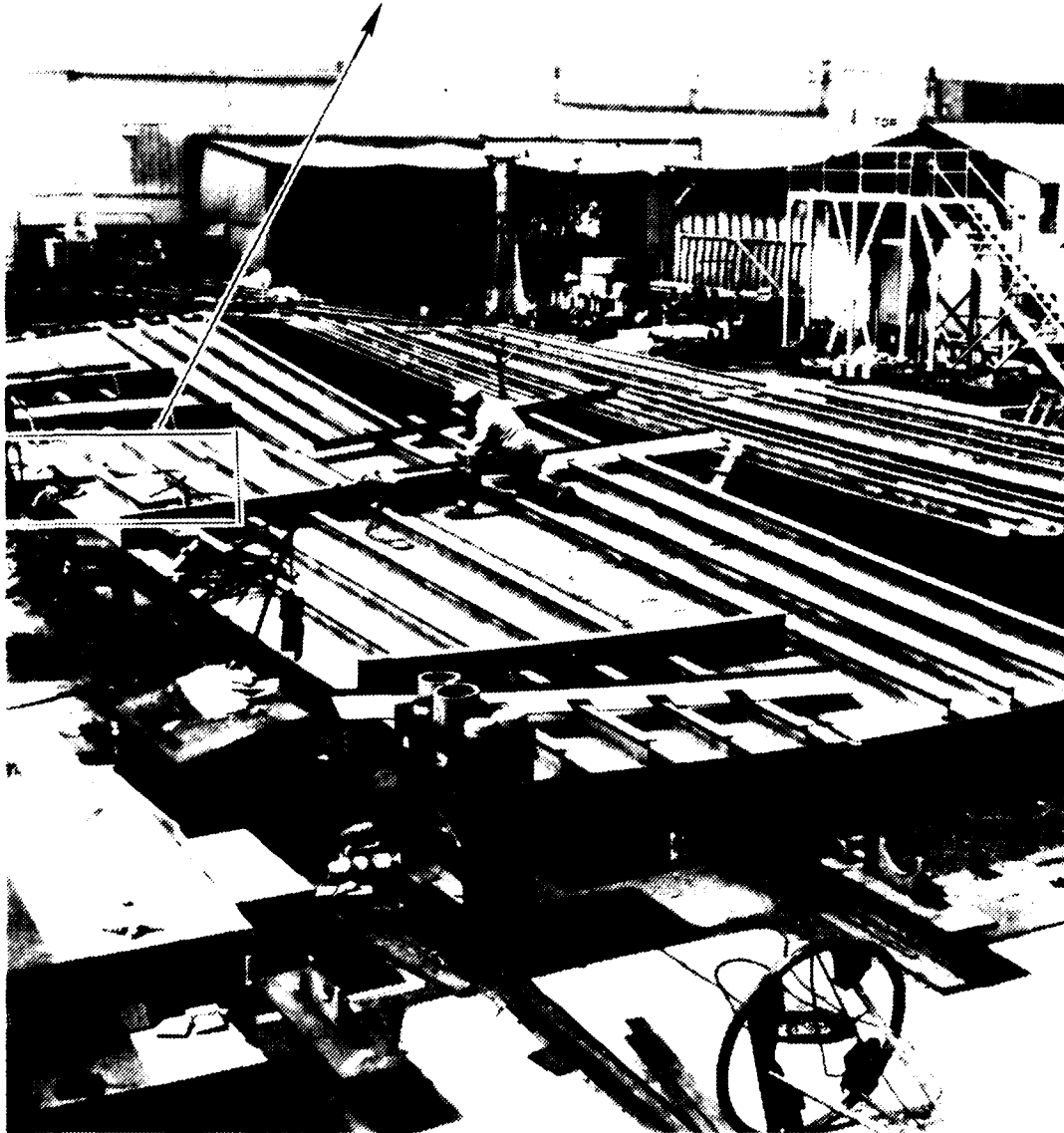
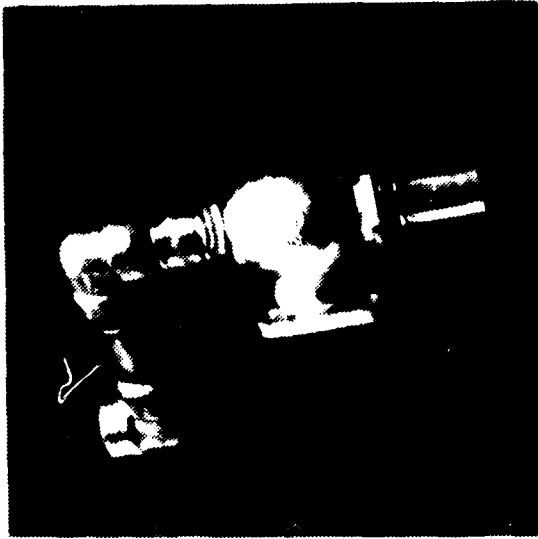

FIG. 17

TYPICAL WELDED PIPE JOINTS AT TODD PACIFIC SHIPYARD

NON-FLAME RESISTANT STEEL
PIPE SIZE 2 IN. DIA. SCHEDULE 40



SLIP-ON-FITTING AND
CHECK VALVE BODY

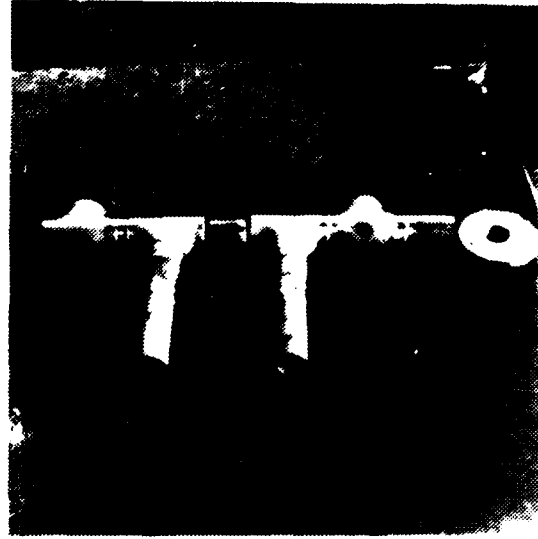

PIPE SPOOL SECTION



SLIP-ON FLANGE

Shipyards are emphasizing the fabrication of pipe modules in the pipe shop. A module may include a number of pipe sections, valves, etc., welded to a bulkhead. This is a large cost saver.

T-Stiffener Fabrication - The procurement of T-stiffeners presents a problem to the shipyards since they are frequently forced to buy I-beams and cut off one flange to obtain the desired dimension. This results in wasted material and extra man-hour costs. High strength stiffeners are normally purchased in lengths of 8 ft. and consequently the shipyards are required to make several butt splices to obtain the 40-ft. lengths for longitudinal T-stiffeners. Thicknesses of the T-stiffeners range from $\frac{3}{16}$ to $\frac{1}{2}$ in. of material, primarily ASTM A36 with some made from HY-80.

The Navy is investigating advanced fabrication techniques for T-stiffeners to provide the shipyards with an alternate source that meets their needs. One such technique is high frequency resistance (HFR) welding. This process is extremely fast (2400 ipm) and produces good joints. In order to be cost effective, very long lengths of structural beams have to be welded during production run. The first 3 to 4 ft. and the last foot have to be discarded as a result of startup and shutdown conditions. Further, the process is presently limited to webs with a thickness of $\frac{3}{8}$ in. or less. Although relatively low heat input is reported, some of the HFR welded T-

stiffeners observed at one shipyard had approximately 1/2 in. warp in a 12-ft. long section.

Subassembly Fabrication - Subassemblies such as machinery supports, foundations, doors, small panels are usually fabricated in a subassembly shop. In one shipyard, a "mini" panel production line is used to fabricate bulkheads and other panels of different size. The work station area is approximately 12 by 30 ft.

At another shipyard, small foundations and other subassemblies smaller than 5 ft. size are welded by a Cincinnati Milacron T-3 robot. This setup utilizes an Aronson positioner and a Fabspec positioner to present the assemblies to the robot.

Sheet metal shops perform an important function in ship construction. In the case of submarine construction, sheet metal shop represents 10 to 15 percent of total fabrication activities.

Sheet metal is cut into the desired shapes, some welded, and shaped. Most of the work involves aluminum. Metal thickness varies between 1/8 to 1/4 in.

High Energy Beam Weld Fabrication

Based upon the information obtained from the visits to the various shipyards listed in Table 6, a number of potential applications of

high energy beam welding for shipyard fabrication were identified. These are presented in Table 7 along with the high energy beam welding processes, laser and electron beam that may be used for each application.

Each of these applications are reviewed and the application of the appropriate high energy beam welding process is discussed.

Panel/Deck Assemblies - Both laser beam and electron beam welding process may be used to fabricate the panel deck assemblies. However, the conventional methods of edge preparation, fitup tolerances, and

TABLE 7

<u>Application</u>	<u>Application of High Energy Beam Welding</u>	
	<u>Laser</u>	<u>Electron Beam</u>
. Panel/deck assemblies	X	X
. T-stiffener to panel weld	X	X
. Piping	X	X
. T-stiffener	X	X
. Metal cutting	X	
. Sheet metal fixtures	X	X
. Ring frame weld		

material handling procedures will not be suitable for either the laser or electron beam welding.

For laser beam welding, the square butt edge weld prep gap tolerances of less than 3 percent of the thickness is necessary for autogenous welds. This fitup tolerance can be achieved. However, if the fitup tolerance exceeds the 3-percent level, then laser welding with filler

metal additions can be used for joints with gaps up to 12 percent of penetration. The present panel production line can be modified to accommodate laser beam welding as shown in Fig. 18.

EB welding using a mobile vacuum chamber, large vacuum chamber, and nonvacuum systems could be adapted for the panel fabrication. The mobile or sliding seal system may require much more development work to meet the high production and quality requirements for shipyard industry. Large chamber welding is the most readily available system. However, a chamber large enough to accommodate a panel plate assembly (4 plates 10 by 40 ft.) would be needed. This fixes the chamber dimensions at 45 ft. length by 45 ft. width and 5 ft. in height. This will result in a substantial cost increase for the system. For the nonvacuum electron beam welding system, the thickness of the plate to be welded would be limited to maximum thickness of 1-1/4-in. Tight fitup tolerances of less than 1 percent of the plate thickness is needed for autogenous weld. With the use of filler metal additions, a gap of up to 3 percent of plate thickness would probably be acceptable.

For the nonvacuum and mobile vacuum system, lead shielding would be needed to decrease the X-ray emission to acceptable industrial safety level. Both systems could be adapted to the panel line with a transversing bridge welding system (Fig. 19) very similar to the present used production welding system with automatic SAW.

FIG. 18

PANEL PRODUCTION LINE UTILIZING LASER WELDERS

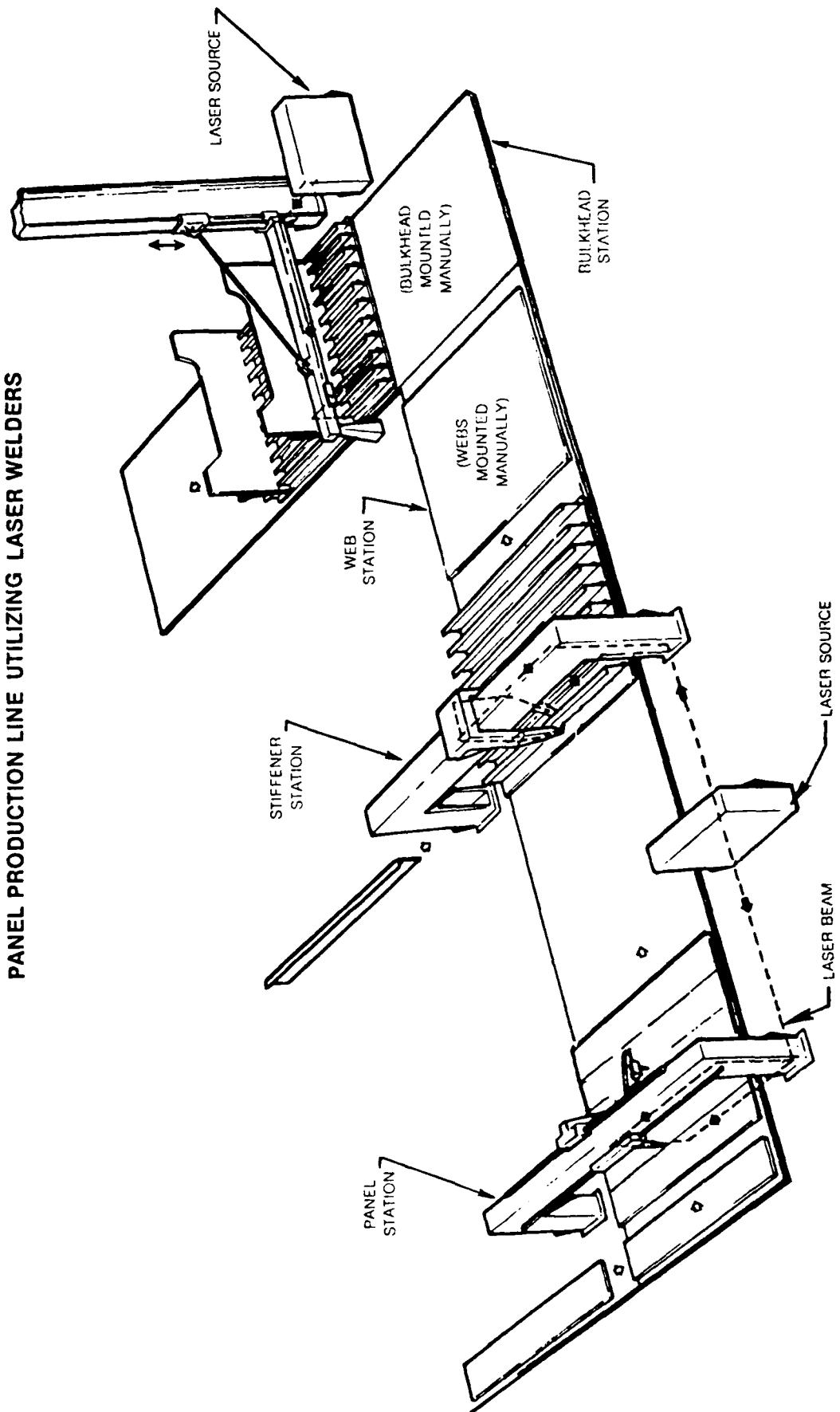

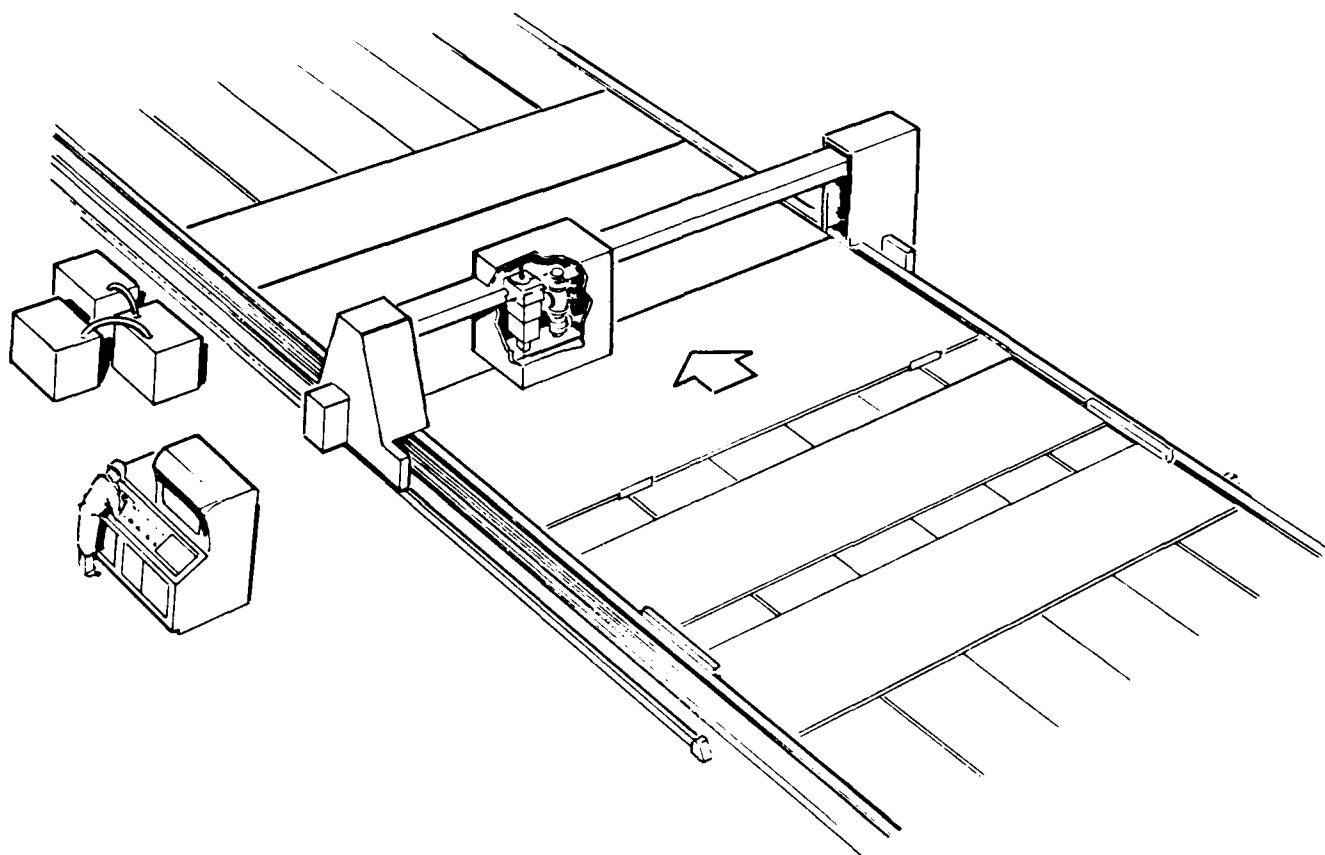

FIG. 19- **NON-VACUUM EB WELDING
FLAT PANEL LINE FABRICATION**

T-Stiffener to Panel Weld - This weld joint design lends itself to both laser and electron beam welding. Fitup tolerances for welding stiffeners to panels may be achieved by using magnetic equipment to force the joint together to approach a zero gap. This does not present a problem for laser beam welding. However, the magnetic field will deflect the EB and adjustments will be necessary such as magnetically depressing or beam shielding that may be economically prohibitive. Thus, other methods of pressing the panel to stiffener for close fitup tolerance will be needed. Because laser and EB welding operate at lower heat inputs than arc welding, the serious problem of thermal distortion currently experienced in the welding will be reduced significantly. This results in less straightening and rework and hence substantial cost savings. Laser beam welding is readily adaptable for this application and all that is needed is the development of a process specification.

EB welding of a section of a T-stiffener to a panel was successfully accomplished in a vacuum chamber (35,36). However, the mobile vacuum and the nonvacuum EB welding has not been demonstrated. These two methods are not readily adaptable for this application due to the joint configuration. The mobile vacuum needs a flat welding surface to achieve a vacuum and the nonvacuum system has a very short working distance and limited penetration capabilities.

Piping - Laser and EB welding can be adapted for pipe welding. The necessary fitup tolerances for square butt edge preparation for laser and EB welding can be obtained by using commercially available pipe cutting equipment. The equipment is relatively inexpensive, easy to operate, and reliable.

Laser beam welding is readily adaptable for pipe welding and could provide an automatic system with relatively high welding speeds. Although laser welding of aluminum and copper has been less than satisfactory, steel and copper nickel which represent a significant fraction of piping for ships are readily weldable.

EB welding has been used in the welding of pipeline from a pipe laying barge (37). A local chamber has been designed and constructed as shown in Fig. 20. This chamber provides a vacuum around the pipe seam to be welded. A 24-in. diameter pipe with 1-1/4-in. wall thickness can be automatically welded in 3 minutes. This equipment has successfully welded over 1200 pipes on 12 different types of materials.

Another EB pipe welding equipment in which the EB gun is positioned inside the pipe is commercially available (38). This equipment can weld pipes ranging from 10 to 30 in. in diameter. A schematic of this system is illustrated in Figs. 21 and 22.

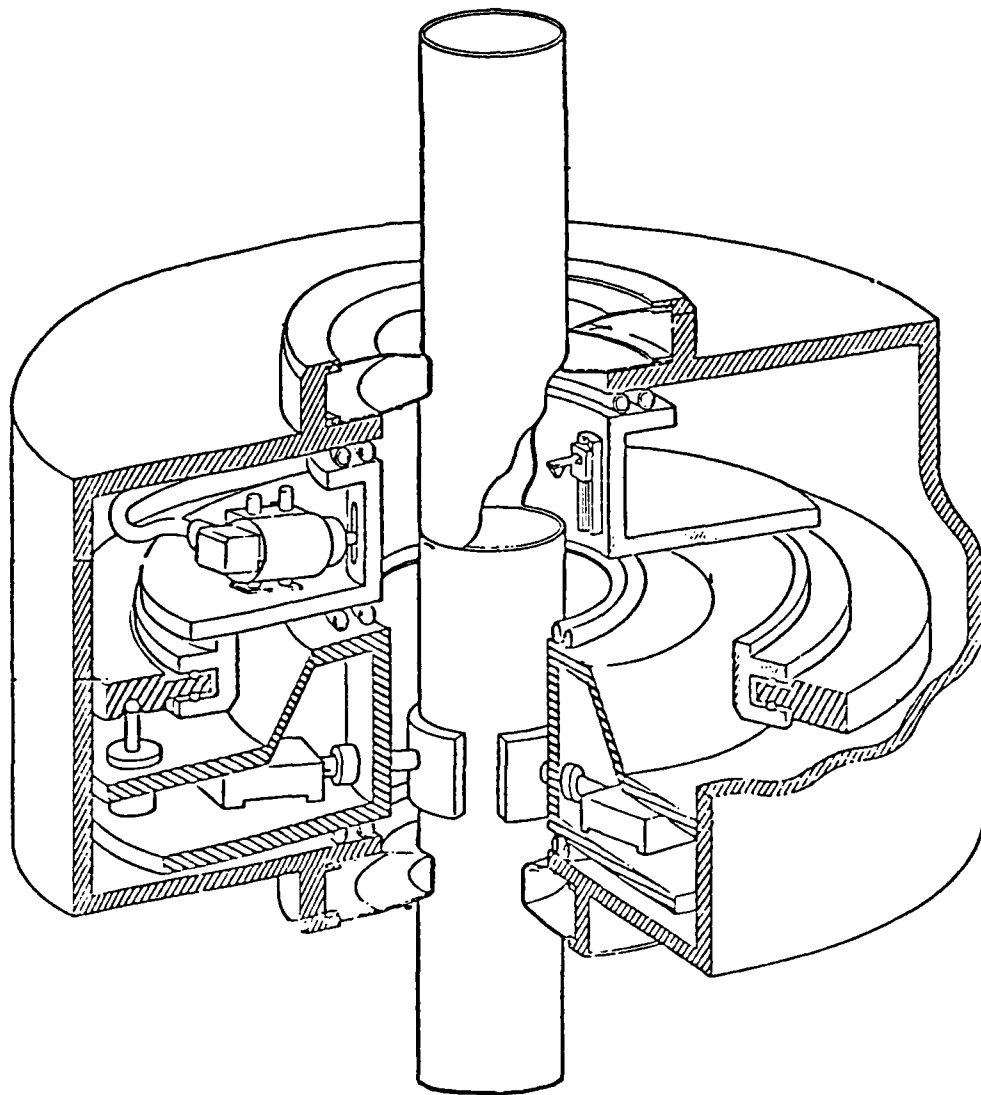

FIG. 20 - EXTERNAL EB SET-UP FOR WELDING PIPE JOINTS

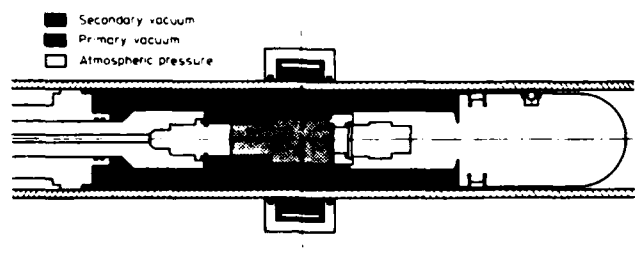

FIG. 21 - SCHEMATIC PRESENTATION OF INTERNAL CHAMBER FOR EB PIPE WELDING. 1-ELECTRON GUN; 2-COUNTER CHAMBER; 3-TURBO-MOLECULAR PUMP; 4-INFLATABLE SEALS. DARK SHADED AREA: SECONDARY VACUUM; LIGHT SHADED AREA: PRIMARY VACUUM

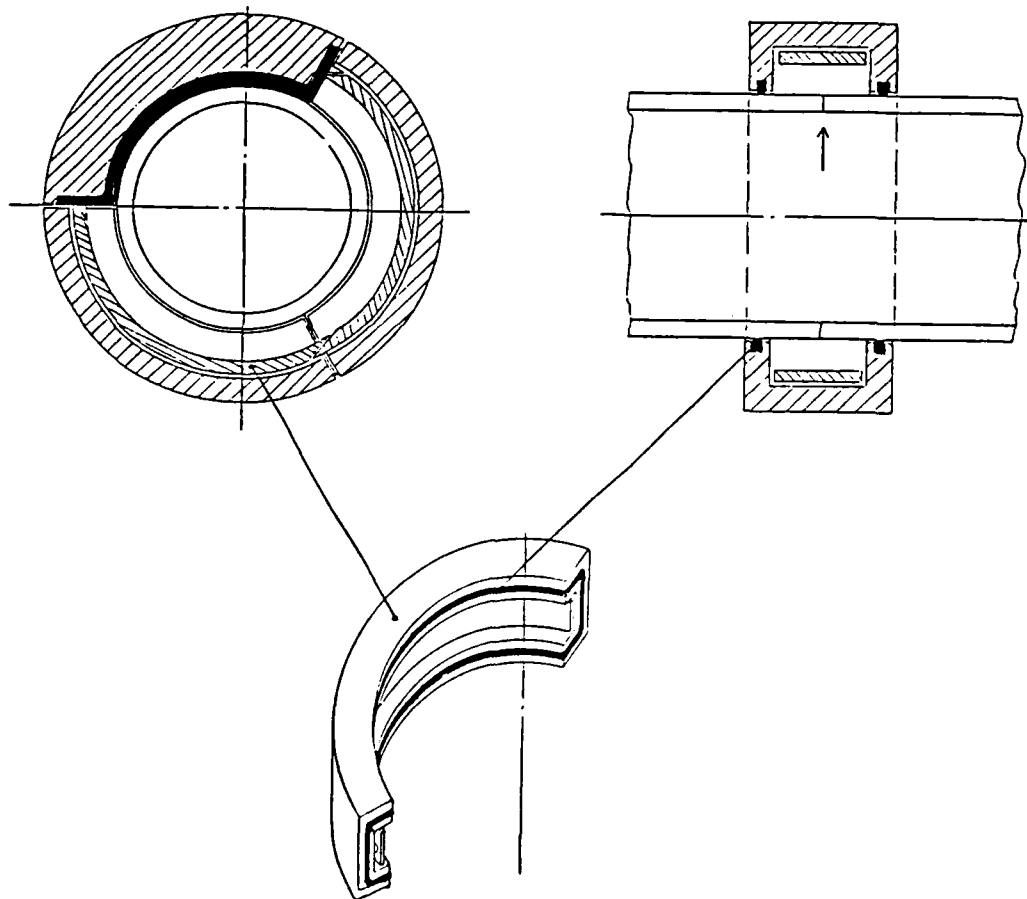

FIG. 22 - SCHEMATIC PRESENTATION OF COUNTER CHAMBER WITH SPECIAL SEALS

The present available EB pipe welding equipment to meet the specific needs of the shipbuilding industry will require considerable development work in seal modifications and holding fixtures.

T-stiffener - This application could use either laser or EB welding. Fitup tolerances to obtain good quality welds is not a serious problem.

All that is needed for laser beam welding is the process certification for T-stiffeners. Other structural shapes such as angle iron channels, boxes, etc., can also be welded. The laser beam welding offers the advantages of flexibility and short time needed to set up and welding.

Current Bending Methods - Laser beam plate bending process presently under development should improve the accuracy of forming the ring (39). Substitution of laser cutting for flame cutting should improve the surface finish. With these improvements, laser beam welding may be attractive for this application.

Sheet Metal Fixtures - Laser beam cutting and welding appears very attractive for these applications. Activity in a submarine sheet metal shop represents 10 to 16 percent of a submarine construction. Laser beam can be used for making, cutting, and welding of materials $\frac{1}{4}$ in. and less. Approximately 90 percent of the welds performed in

the sheet metal shop are nonqualifying since the components do not need to satisfy military structural standards. Therefore, laser beam welds in aluminum should be satisfactory.

Economic Analyses of High Energy Beam Welding

Having identified areas of potential application of high energy beam welding, a preliminary analysis was performed on each area to determine the possible economic benefits relative to conventionally used welding processes. The analyses were performed by two different organizations and consequently the input information and assumptions used for the laser beam and electron beam welding were different. In evaluating these preliminary results, these factors and other cost uncertainties must be considered in the overall economic benefits. The various cost analyses are presented below.

Pipe Welding - A cost estimate was made for performing a pipe weld on an 8-in. diameter schedule 40 carbon steel pipe by laser beam welding. At one shipyard, manual GTAW was used and formed a basis for comparison. All the labor and material costs were estimated and an hourly fixed charge for capital cost of equipment was included in the total cost. Laser welding systems with two levels of beam output power 6 kW and 9 kW were evaluated. The welding speeds corresponding to these power levels were 25 and 55 ipm, respectively, and a full penetration single pass weld was used.

Fabrication costs per panel were determined for both a single 8-hour shift and a 16-hour per day two shifts. As shown in Table 8, cost savings of 30 to 50 percent are possible using laser beam welding with the amount of savings, depending upon how effectively the high cost laser system is utilized.

However, the cost of panel fabrication by the advanced design 1-sided SAW competes favorably with the laser beam welding. This results from the significant improvement in production rate and lower capital charges. One factor not considered in this estimate is the cost to straighten the thermally distorted panels that result from the high heat inputs.

For the electron beam welding of 1- and 1-1/2-in. thick panels of HSLA, the cost savings excluding capital cost of the equipment and operating cost are greater for the 1-1/2-in. thick panels. This may change, depending upon the capital cost. The 1-sided SAW was more efficient than the 2-sided process and costs slightly more per panel than EB welding. The 1-sided SAW process may be limited to plate thicknesses of one inch or less because of thermal distortion problems.

T-Stiffener to Panel - In the analysis of laser beam welding, a 40-ft. square panel with 40-ft. long T-stiffeners spaced two feet apart was considered. The panel was 1/2 in. thick, and the dimensions of the 19 stiffeners were 4-in. web and flange section

with a 3/16-in. web thickness. Panel and stiffeners were carbon steel. Automatic turn-fillet welding with FCAW was the conventional welding process. Three laser beam welding system designs were evaluated with total output ratings of 6, 12, and 18 kW. Each system design is assumed to have two laser units, each providing a beam with one-half the system total rated power to the respective edge of the joint. The focus heads are gantry mounted like those shown schematically in Fig. 23.

As seen in Table 8, application of laser beam welding to the attachment of stiffeners to panels can result in substantial cost savings. For example, a 12-kW laser welding system utilizing two 6 kW lasers can reduce the cost to less than one-half the fabrication by FCAW. Further, the significant reduction in heat input of laser welding should effect further cost reductions due to the alleviation of thermally induced distortion and subsequent straightening operations.

The results of the cost analysis of EB welding this assembly compared to the conventional 2-sided SAW show EB welding to be more economical. However, when the capital equipment and operating costs are considered, the cost differential may be less, equal, or greater than SAW.

FIG. 23

SCHEMATIC DRAWING OF LASER FILLET WELDER SYSTEM FOR MOUNTING STIFFENERS

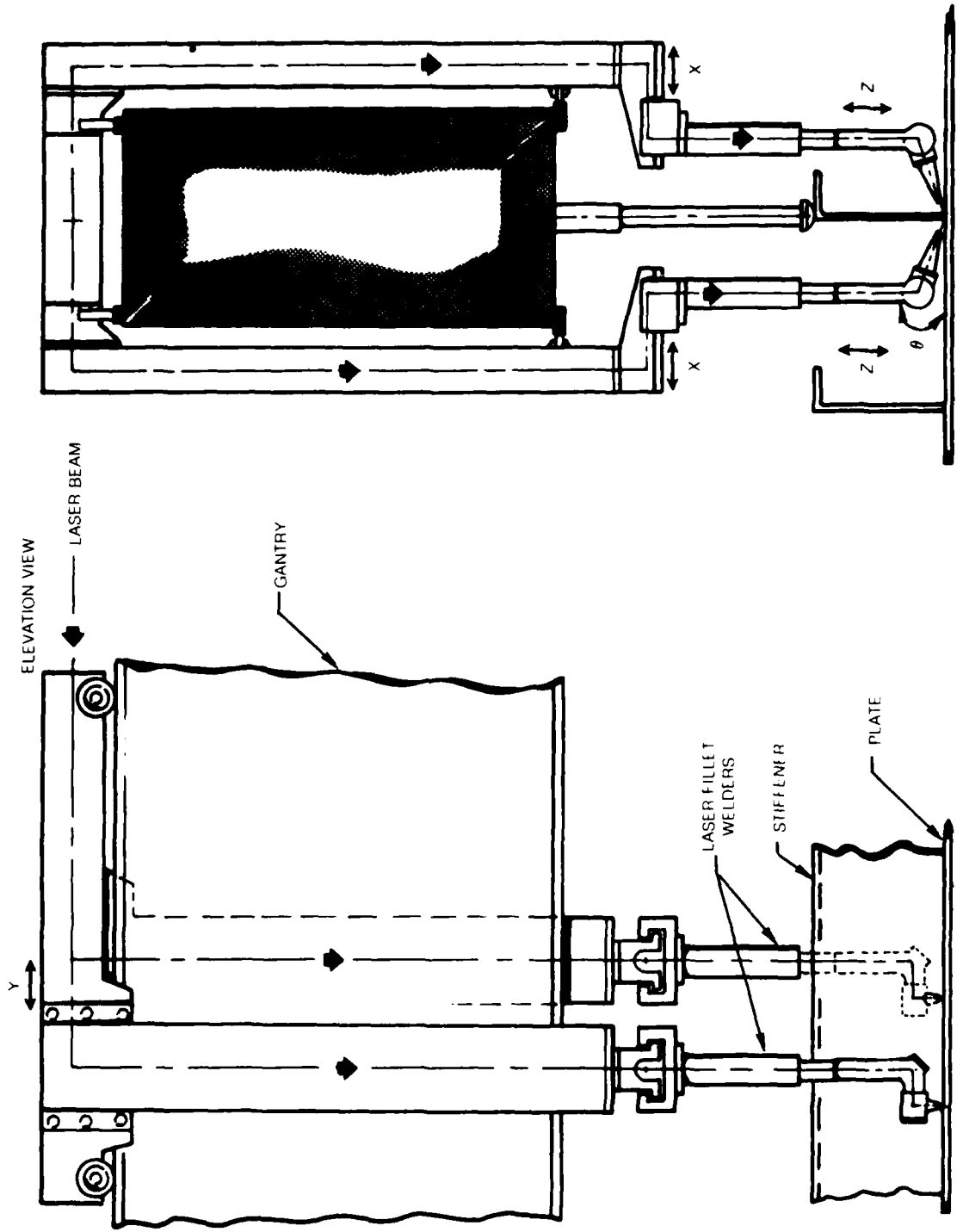

As shown in Table 8, there is a significant reduction in cost in using laser beam welding. The primary reason for this cost benefit is the 10-fold increase in production rate due to the higher laser beam welding speeds. It should be noted that the gain in welding speed between the 6 kW and 9 kW power level did not result in a significant cost reduction because a condition of diminishing return was reached.

A cost analysis for EB pipe welding was not performed.

Flat Panels - The flat panel model used for the laser beam welding analysis consisted of four 10- by 40-ft. plates 1/2 in. thick of ASTM A36 steel butt welded to form a 40-ft. square section. Automatic SAW using the conventional 2-sided process and a 1-sided welding process that is currently being considered to improve productivity were evaluated. A square butt joint configuration was used for the 2-sided weld, while a single vee, 50° included angle with zero gap between joint was used for the 1-sided SAW. A modified series, triple wire, tandem-arc welding equipment is utilized in this system. For the laser beam welding systems, two output powers, 15 and 20 kW were evaluated. Welding speeds for these two power levels were 45 and 90 imp, respectively. Square butt welds with a gap of 1/16 in. (12.5 percent of plate thickness) were assumed. Filler material was added since the gap exceeded the 3 percent of plate thickness limit for autogenous welding.

TABLE 8
 COST ESTIMATES FOR LASER AND ELECTRON BEAM WELDING FOR SHIPYARD FABRICATION

Application	Conventional	Laser Beam Welding Power Output	Conventional In Chamber Welding	Electron Beam Welding*
. Pipe Joining - 8-inch diameter Schedule 40 carbon steep pipe Manual GTAW		6 kW \$30		
Unit cost for weld joint	\$55	9 kW \$34	Not applicable	
. Flat Panels - 40' by 40', 1/2" thick 36 plate Automatic SAW	2-sided 1 2	15 kW 1 2	40' by 40', 1" and 1-1/2" thick HSLA steel Automatic SAW 2-sided 1-sided EB	1 inch 1-1/2 inch \$ 846 \$ 824 \$ 726
No shifts				\$1444 \$ 816
Unit cost per panel-\$381	\$306	\$21,200 \$166	\$255 \$163 \$246 \$154	
. T-stiffener to panel - 40' by 40', 1/2" thick A36 19, 4- by 4- by 3/16-inch stiffener Automatic FCAW	2-sided 1 2	6 kW 1 2	40' by 40', 1" and 1-1/2" thick HSLA steel Automatic SAW 2-sided	1 inch 1-1/2 inch \$1383
No shifts				\$2604
Unit cost per panel-\$1418	\$1320	\$1412 \$862 \$977 \$611 \$748 \$498	\$2006	\$1383
. T-stiffener - 40' length, 3/16" web thickness MFR Welding		20 kW \$19		
Unit cost	\$60 Mode 1 \$6 Mode 2			

*Does not include capital equipment cost and operating cost.

T-Stiffener - Laser beam welding of T-stiffeners with a finite length of 40 ft. and web thicknesses ranging from 1/8 to 9/16 in. was considered in this very cursory cost analysis. This was compared to the conventional fabrication process of high frequency resistance (HFR) welding. Two operating modes were considered for the HFR welding process: in mode 1 the stiffeners are assumed to be fabricated from flat plate of proper thickness and precut to 40-ft. lengths; and in mode 2, they are assumed to be fabricated from coiled steel strips in continuous running lengths and subsequently cut to the desired 40-ft. lengths.

As seen in Table 8, the laser beam welding competes favorably with the HFR welding process if the stiffeners are welded from precut 40-ft. long stock as described for mode 1 operation. These attractive economics occur because a significant amount of material (4 ft. from leading edge and 1 ft. from the trailing edges) has to be discarded as startup and shutdown losses. For mode 2 operation, the potential cost of laser beam welding is nullified.

A cost estimate for EB welding of this structure was not performed because of the lack of sufficient and accurate information on fabrication costs.

General Comments on High Energy Beam Welding Systems - Laser beam welding is ready for implementation for applications normally

conducted indoors such as pipe joining, sheet metal shop and fabrication of structural beams. Full penetration high quality welds have been demonstrated in most of the materials used for these applications. Implementation for the fabrication of panels and the welding of T-stiffeners to panels will require tight joint fitup for autogenous welds. However, laser welding with filler metal addition can be used for joints with gaps no greater than 12 percent of the penetration.

The large chamber concept for EB welding is the most practical method for the welding of panels and T-stiffeners to panels and possibly other structures. However, the high capital cost may not make this economically attractive. The mobile or sliding seal concept is more feasible from the economic standpoint but considerable development work is necessary before it could be applied on a production basis. Welding of mild steels would not be as economical due to the decreased cost of weld consumables as compared to HSLA steels.

CONCLUSIONS AND RECOMMENDATIONS

On the basis of this paper study, a number of conclusions and recommendations on high energy beam welding of ship structures have been prepared and are presented below.

CONCLUSIONS

- . Industrial EB and laser beam welding systems can be adapted for use in the shipbuilding industry and provide economic benefits. The commercial laser and electron beam welding systems have demonstrated high reliability and low maintenance.
- . Shipyard applications for both laser and EB welding include pipe welding in the pipe shop, fabrication of structural beams (T-stiffeners), flat panel fabrication, T-stiffeners to panel assemblies and nonqualifying welds in sheet metal shop. Laser beam welding systems are ready for implementation for most applications.
- . The conventional materials for shipyard construction can be welded by both laser and electron beam welding. Preliminary results on laser and EB weldments show mechanical properties equal to or better than conventional welding methods.
- . The increased productivity associated with faster welding speeds and high level of automation can result in substantial cost benefits for laser welding. The economic benefits of EB welding cannot be stated because of incomplete cost analysis.

- . The low heat input requirements for welding reduce the energy consumption compared to arc welding and also decreases the distortion in welded components.
- . Based on productivity increases only, the preliminary cost analysis indicate potential savings of 15 to 45 percent in pipe welding, 30 to 60 percent in fillet welding T-stiffeners to panel, and 30 to 45 percent in butt welding plates by substituting laser beam welding for conventional arc welding processes.

RECOMMENDATIONS

- . The results of this paper study have shown that laser welding of ship structures can provide important economic benefits over the conventional arc welding processes. Therefore, further studies are recommended to qualify the laser welding processes for selective fabrication applications. These include:
 - . Further investigations on laser welding of shipyard structural materials with particular emphasis on HY steels and HSLA steels such as A710. The use of filler metals, preheat and postheat and mechanical properties should be evaluated.
 - . Conceptual design studies on the welding systems to define critical technology requirements. For electron beam welding, the studies should include the development of mobile or sliding seal equipment for panel fabrication and for laser welding the interface requirements between the laser, beam delivery/gantry system, work handling fixtures, and the workpiece.

- . Studies on thermal distortion of thin plates and how this can be minimized and controlled by laser and EB welding. Analytical models need to be developed and verified by experimental work.
- . A more complete economic analysis should be performed that would include the impact of increased productivity resulting from high energy beam welding on the overall ship fabrication cost.

REFERENCES

1. Klauminzer, Gary K.: Twenty Years of Commercial Lasers--A Capsule History, *Laser Focus/Electro-Optics*, December 1984, pp. 54-79.
2. Carstens, J. P.: High Power CO₂ Materials Processing Technology at United Technologies Research² Center. UTRC paper presented at the International Workshop on Material Processing with CO₂ High-Power Lasers, Stuttgart, West Germany, April 1982. ²
3. Bannister, Robert D.: Lasers and Robots--"A Tale of Two Technologies," Robots 8th Conference Proceedings, Volume 1, June 1984.
4. Hitz, C. Breck: The Marketplace for Materials--Processing Lasers. *Lasers and Applications*, January 1985, pp. 59-61.
5. Carstens, J. P., UTRC, East Hartford, CT, private communications, December 1984.
6. Duhamel, R. P.: Single-Module Laser Welding Performance. UTRC Report No. R81-112134-21, December 1, 1981.
7. UTRC Brochure: Industrial Applications of High-Power Lasers. June 1981.
8. Metzbower, E. A., et al.: Laser Beam Welding of ASTM A36 Steel, paper presented at a Symposium sponsored by the Physical Metallurgy and Solidification Committees of the Metallurgical Society of AIME, February 1981.
9. Duhamel, R. F. and C. M. Banas: Laser Welding of Steels and Nickel Alloys, ASM paper No. 8301-020 presented at 1983 ASM Conference on Applications in Materials Processing. January 1983.
10. Carstens, J. P.: The Future of High-Power Laser Welding. Paper presented at Laser 83 Opto-Elektronik, Munich, Germany, June 1983.
11. Carey, Howard B.: *Modern Welding Technology*, Prentice Hall, Inc., 1979.
12. Hunt, J. F.: Welding Steam Headers by Narrow Gap GMAW. *Welding Design and Fabrication*, December 1982.
13. Breinan, E. M., et al.: Fusion Zone Purification During Welding with High Power CO₂ Lasers. UTRC Report R11087-2, April 1975.

14. Banas, C. M. and G. T. Peters: "Study of the Feasibility of Laser Welding in Merchant Ship Construction." Final Report to Bethlehem Steel on their Contract 2-36214 with U.S. Department of Commerce, August 1974.
15. Metzbower, E. A., et al.: Mechanical Behavior of Laser Beam Weldments, paper presented at a conference sponsored by the Joining Division of ASM, November 1981.
16. Metzbower, E. A., et al.: Mechanical Properties of Laser Beam Welds. Welding Journal, July 1984, pp. 39-43.
17. Banas, C. M.: Laser Welding to 100 kW. UTRC Report R76-912260-2, February 1977.
18. Carstens, J. P., et al.: Laser Welding of HY-80 Steel, UTRC Report R78-914276-5, April 1979.
19. Breinan, E. M., et al.: Evaluation of Basic Laser Welding Capabilities, UTRC Report R77-911989-10.
20. Banas, C. M., et al.: Laser Welding of HY-80 Steel, UTRC Report R110952-32, April 1978.
21. Stoop, J., et al.: A Metallurgical Characterization of HY-130 Steel Welds. Welding Journal Research Supplement, November 1978.
22. Metzbower, E. A., et al.: Laser Welding of Structural Alloys, paper presented to International Conference on Welding Technology for Energy Applications, sponsored by AWS, May 1982.
23. Denny, P. E., et al.: Mechanical Properties and Physical Metallurgy of HSLA Steel Laser Beam Weldments, paper presented at 1983 International Conference on Technology and Applications of High Strength Low Alloy Steels. ASM Paper No. 8306-027, October 1983.
24. Denny, P. E., et al.: Mechanical Properties of Laser Welded ASTM 710 Report to be published by NRL.
25. Moon, D. W., et al.: The Effects of Inconel 600 on the Toughness of HY-Steel Laser Welds, paper presented to the conference on Application of Lasers in Materials Processing, January 1983.
26. Baeslack, III, W. A. and C. M. Banas: A Comparative Evaluation of Laser and Gas Tungsten Arc Weldments in High-Temperature Titanium Alloys. Welding Research Supplement, July 1981.
27. Snow, D. B., et al.: Evaluation of Basic Laser Welding Capabilities, UTRC Report R79-911989-17, July 1979.
28. Elliott, S., "The Effect of Process Parameters on the Weld Metal

Toughness of EB Welds in a Range of C and C-Mn Steels - A Preliminary Investigation," Welding Institute Res. Report 169/1981, December 1981.

29. Russell, J. D., et al., "Electron Beam Welding of Structural Steels," Metal Construction and British Welding Journal, 6(19), pp. 307-312.
30. Goldak, J., Bibby, M., "The Toughness of EB Welds in HSLA Steels," Proceedings of International Conference, Rome 1976, American Society of Metals and Associazione Italiana de Metallurgia.
31. Wong, R., Brenna, R. "Static and Dynamic Properties of Electron Beam Welds in 1 Inch Thick HY 80 Steel," DTNSRDC Report, August 1982.
32. Wong, R., "Electron Beam Welding of HY 80 Steel Tees," DTNSRDC Report, September 1981.
33. Stoop, J., Metzbower, E. A., "A Metallurgical Characterization of HY 130 Steel Welds," Welding Journal Research Supplement, November 1978.
34. Meeting with J. P. Maciel and R. K. Nordeen of Todd Pacific Shipyard in San Pedro, CA, December 5, 1984.
35. Ellison, H., Payne, K., "Electron Beam Welding Technology for Ship Structures," April 1979, p. 26.
36. Wong, R., Czysyca, E., "Electron Beam and Sliding Seal Electron Beam Welding of HY 130 Steel Panels," David Taylor Naval Ship Research and Development Center Report, August 1981.
37. Sivry, B., Connet, C., "Electron Beam Welding of J-Curve Pipelines," Offshore Technology Conference, 1980, paper OTC 3746, pp. 99-103.
38. Sayegh, G., Cazes, R., "The Possibilities for Use of Electron Beam Welding in Pipeline Welding in the J Position," 1979.
39. Meeting with J. B. Acton of Todd Pacific Shipyard, December 6, 1984.

END

DOTIC

8-86