

AD-A167 712

THE ARMY-OF-EXCELLENCE DIVISIONAL CAVALRY SQUADRON -- A 1/1  
DOCTRINAL STEP BACKWARD(U) ARMY COMMAND AND GENERAL  
STAFF COLL FORT LEAVENWORTH KS SCHOO.. P S KINDSVATTER

UNCLASSIFIED

82 DEC 85

F/G 15/3

NL

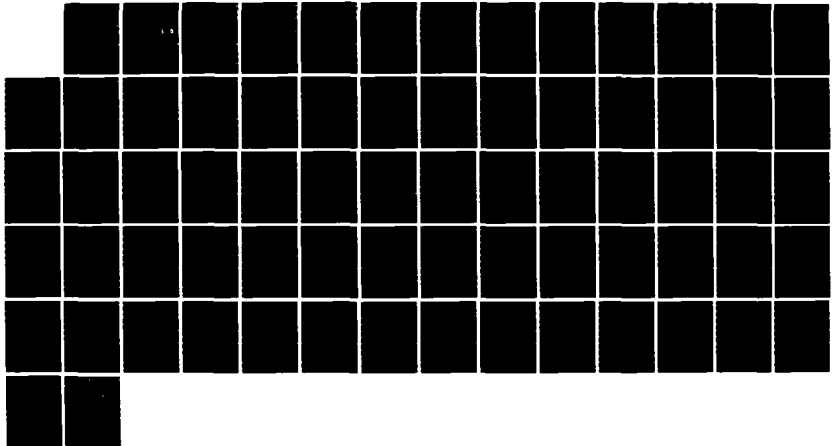

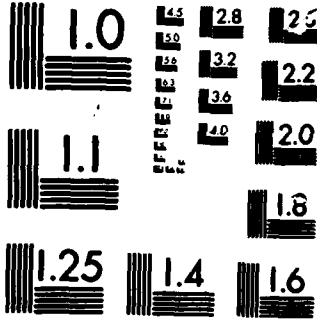

MICROCOPY

CHART

2

The Army-of-Excellence  
Divisional Cavalry Squadron  
--A Doctrinal Step Backward?

AD-A167 712

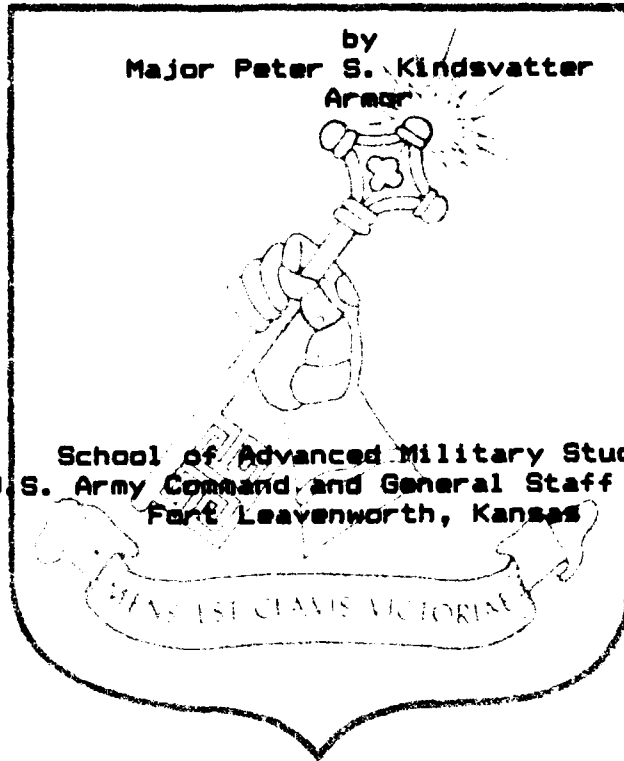

DTIC  
ELECTE  
MAY 22 1986  
S D

DTIC FILE COPY

2 December 1985

Approved for public release; distribution unlimited.

**The Army-of-Excellence  
Divisional Cavalry Squadron  
--A Doctrinal Step Backward?**

**by  
Major Peter S. Kindsvatter  
Armor**

**School of Advanced Military Studies  
U.S. Army Command and General Staff College  
Fort Leavenworth, Kansas**

**2 December 1985**

**Approved for public release; distribution unlimited.**

School of Advanced Military Studies  
Monograph Approval

Name of Student: MAJ Peter S. Kindsvatter

Title of Monographs: The Army-of-Excellence Divisional Cavalry  
Squadron--A Doctrinal Step Backward?

Approved by:

Thomas G. Ferguson  
(LTC Thomas G. Ferguson, Ph.D.)

Seminar Leader

Richard Hart Sinnreich  
(COL Richard Hart Sinnreich, MA)

Director, School of Advanced  
Military Studies

Philip J. Brookes  
(Philip J. Brookes, Ph.D.)

Director, Graduate Degree  
Programs

Accepted this 31st day of December 1985.

ABSTRACT

THE ARMY-OF-EXCELLENCE DIVISIONAL CAVALRY SQUADRON--A DOCTRINAL STEP BACKWARD? by MAJ Peter S. Kindsvatter, USA, 64 pages.

This monograph examines the organization and missions of the Army-of-Excellence divisional cavalry squadron as outlined in the 1980 Operational and Organizational Concept for Division and Corps 86 Cavalry and in Field Circular 71-8, AOE Close Combat Heavy Brigade and Divisional Armored Cavalry Squadron (Preliminary Draft), 1984. The AOE squadron, without tanks and at greatly reduced strength, is to be used primarily as a reconnaissance-by-stealth force, with secondary emphasis on screening, line-of-communication security, and command-and-control enhancement.

The AOE squadron is a radical departure from its "fighting cavalry" predecessor, which was a strong squadron equally capable of performing reconnaissance, security, and economy-of-force missions. The AOE squadron seems to be a return to the pre-World War II armored division reconnaissance battalion--a lightly armed and armored force also designed primarily for reconnaissance by stealth.

This monograph, by examining the experiences of cavalry leaders, various research reports, review board findings, after-action reports, and official manuals, traces the evolution of the reconnaissance battalion from a reconnaissance-by-stealth unit into a strong, multipurpose cavalry squadron and then back to a reconnaissance-by-stealth unit under AOE. The arguments in favor of reconnaissance by stealth are examined: Fighting distracts reconnaissance units from their primary mission and causes unnecessary casualties, and cavalry units sufficiently armed and armored to permit combat lose the traditional cavalry advantage of mobility. Advocates of fighting cavalry refute these arguments and also point out that the divisional cavalry squadron must be able to combat the tanks that will be found in Soviet reconnaissance and security elements.

QUALITY INSPECTED  
3

Accession For	
NTIS CRA&I	<input checked="" type="checkbox"/>
DTIC TAB	<input type="checkbox"/>
Unannounced	<input type="checkbox"/>
Justification	
By	
Distribution /	
Availability Codes	
Dist	Avail and/or Special
A-1	

## Table of Contents

	Page
Section I. Introduction.....	1
Section II. Historical Development of the U.S. Army Divisional Cavalry Squadron.....	3
Section III. Division 86 and the Doctrinal About-Face: Return to "Sneak-and-Peek" Reconnaissance.....	23
Section IV. The Arguments For and Against Fighting Cavalry.....	27
Section V. Conclusion: The Time and Mission Dilemmas....	37
APPENDIX A Reconnaissance Battalion (Armored), 10 July 1940.....	41
B Armored Reconnaissance Battalion, 1 March 1942.....	42
C Cavalry Reconnaissance Squadron, 15 September 1943.....	43
D Reconnaissance Battalion, 14 May 1948.....	44
E Armored Cavalry Squadron, June 1964.....	46
F Armored Cavalry Squadron, 10 January 1984.....	48
Endnotes.....	49
Bibliography.....	57

## I. Introduction

After World War I, even the staunchest advocate of horse cavalry had to admit that the advent of the machinegun and the rapid-firing artillery piece had spelled the demise of the mounted charge. As the postwar American Expeditionary Force (AEF) Cavalry Board admitted, "mounted combat of large bodies of cavalry is probably a thing of the past."<sup>1</sup> But few cavalrymen were ready to admit that the horse had had its day, arguing that the trench warfare of the stalemated Western Front had been an aberration. Future wars would again be wars of movement, and the cavalry, while it might now have to dismount to close with the enemy, would remain a vital part of the Army's fighting force. The AEF Cavalry Board concluded that "the role of cavalry, in general, had changed little when considering war of movement."<sup>2</sup>

What was horse cavalry's role? As pointed out in the 1941 FM 100-5, Field Service Regulations: "The primary mission of Cavalry is combat."<sup>3</sup> As late as June 1944, FM 100-5, Field Service Regulations, continued to view horse cavalry as a viable fighting force, assigning to it a wide variety of combat missions:

Horse cavalry capabilities are offensive combat; exploitation and pursuit; seizing and holding important terrain until the arrival of the main forces; ground reconnaissance; ground counterreconnaissance (screening), both moving and stationary; security for the front, flanks, and rear of other forces on the march, at the halt, and in battle; delaying action; covering the retrograde movements of other forces; combat liaison between large units; acting as a mobile reserve for other forces; harassing action; and surprise action against designated objectives deep in hostile rear areas.<sup>4</sup>



The U.S. Army's horse cavalry, however, would perform none of these cavalry missions during World War II because, except for the 26th Cavalry Regiment of the Philippine Scouts, no U.S. Army horse-mounted units would fight in the war.<sup>3</sup> Who then performed these vital reconnaissance, security, and combat missions? The task fell to the mechanized reconnaissance groups, squadrons and troops--organizations not originally intended to perform most of those missions. Unlike the all-purpose horse cavalry, the mechanized reconnaissance elements were intended to be special-purpose units "organized, equipped, and trained to perform reconnaissance missions employing infiltration tactics, fire, and maneuver. They engage in combat only to the extent necessary to accomplish the assigned mission."<sup>4</sup>

Not surprisingly, such specialized units were hard pressed to perform the wide range of traditional horse-cavalry missions. Changes in organization, equipment, and doctrine would be necessary before the reconnaissance units were capable, on their own, of adequately performing those missions. This paper will trace the development of one of these specialized units--the reconnaissance battalion of the 1940 U.S. armored division--into a worthy successor to the horse cavalry, able to perform all of the missions ascribed to the horse cavalry in the 1944 Field Service Regulations. This transition began following World War II and carried through the period of the Korean and Vietnam Wars, with changes in organization and equipment making the reconnaissance battalion increasingly capable of performing a wide range of combat missions. Even the

battalion's name would change to "armored cavalry squadron" to reflect this capability.

This paper then discusses the changes wrought in this cavalry squadron by the 1980 Division 86 Study and by the follow-on Army-of-Excellence (AOE) Study--changes which reduce the squadron's strength and relegate it to its former specialized mission of reconnaissance by stealth. This paper's primary purpose is to present the arguments for and against this doctrinal reversal and the implications of the squadron's new organization for its parent formation, the AOE heavy division. The personal experiences and opinions of cavalry and armor leaders, the findings of various research reports and review boards, examples provided by historical accounts and after-action reports, and information on doctrine and missions as provided by various official manuals will all be used to support this analysis.

## II. Historical Development of the U.S. Army Divisional Cavalry Squadron

The divisional cavalry squadron in the U.S. Army had its genesis in 1940 as the reconnaissance battalion organic to each of the two newly formed armored divisions. This reconnaissance battalion would undergo numerous organizational, doctrinal, and equipment changes following World War II, the net effect of which would be to transform it from a lightly armed and armored force designed primarily for reconnaissance into a heavily armed and armored combined-arms force capable of performing a wide range of combat missions. This

trend continued until August 1980, when the Chief of Staff of the Army approved the Division 86 Organizational and Operational Concept.

The 1st and 2d Reconnaissance Battalions were activated on 15 July 1940 as part of the 1st and 2d Armored Divisions, respectively. (See organizational chart at Appendix A.) These battalions were redesignated as the 81st and 82d Reconnaissance Battalions, respectively, on 12 May 1941. They participated with their parent divisions in a series of maneuvers in 1941, the results of which led to the reorganization of all armored divisions on 1 March 1942. This reorganization also affected the divisions' reconnaissance battalions. (See Appendix B for the 1942 organization.) The 2d and 3d Armored Divisions and their reconnaissance battalions would remain in this 1942 configuration, known as the "heavy" armored division organization, throughout World War II. The other fourteen armored divisions formed before or during World War II were organized or reorganized under yet another table of organization, the September 1943 "light" armored division organization. The term "light" was used because the 1943 organization contained only three tank battalions, while the "heavy" 1942 organization contained six. The reconnaissance battalions of the "light" armored division were designated "cavalry reconnaissance squadrons" and differed from the 1942 organization primarily in the addition of a fourth reconnaissance troop and in the consolidation of the assault guns into a separate troop (See Appendix C).<sup>7</sup>

The equipment and organization of the World War II

reconnaissance squadron reflected its intended doctrinal employment.<sup>9</sup> Prewar manuals assigned the reconnaissance battalion the primary mission of reconnaissance, even to the exclusion of the other traditional cavalry missions of security and combat. One of the first manuals produced by the newly formed Armored Force stated in March 1942: "The principal function of the battalion is reconnaissance. It should not be assigned security or combat missions that will interfere with the performance of reconnaissance."<sup>7</sup> While it was recognized that "there may be many occasions when it will be necessary to fight to obtain the desired information," the reconnaissance battalion "as a general practice seeks to avoid combat."<sup>10</sup>

The equipment of the reconnaissance squadron reflected this doctrine. Scouts were mounted in lightly armored cars and unarmored jeeps, and it was felt that the M3 light tank with its 37-mm gun and the 75-mm assault gun would provide sufficient firepower to handle light resistance on those occasions when fighting was necessary. The squadron had no medium tanks, tank destroyers, artillery, engineers, or (starting with the 1942 organization) infantry.

Prewar training dutifully emphasized reconnaissance by stealth. MAJ I. D. White, commanding the 2d Armored Division's 82d Reconnaissance Battalion (and later to command its parent division during the war), warned his fellow cavalrymen in 1941 not to ruin the effectiveness of reconnaissance by engaging too readily in combat:

Leaders must be guided by the principle that the best reconnaissance is performed by stealth

and that when the presence of their unit has been disclosed to the enemy by the noise incident to combat, the enemy will bend every effort toward their destruction...."<sup>11</sup>

LTC H. H. D. Heiberg, commander of MAJ White's sister battalion, the 81st Reconnaissance Battalion of the 1st Armored Division, shared the same opinion. Following the 1941 maneuvers, which earned for the 81st the title of "Phantom Battalion" in recognition of its stealthy reconnaissance abilities, LTC Heiberg reported:

There is no doubt that our losses could have been reduced materially had the various patrol leaders resisted the temptation of attacking isolated and unsuspecting hostile troops.... This is a problem that confronts most reconnaissance commanders.<sup>12</sup>

In short, the reconnaissance battalions were trained and equipped primarily to conduct reconnaissance, and stealth was emphasized over combat. Experience in the European Theater, however, was to show the inadequacy of this doctrine. For example, the 81st "Phantom Battalion" discovered during its first combat in North Africa (15 January - 9 May 1943) that avoiding combat through stealthy reconnaissance was easier said than done. Suffering frequent air and artillery attacks, the 81st Reconnaissance Battalion delayed, defended, attacked, and screened in addition to conducting reconnaissance. During the Battle of Kasserine, one company was surrounded and after a hard fight only ten men escaped to rejoin the battalion.<sup>13</sup>

A few warning cries were sounded before the war concerning the inadequacy of reconnaissance units designed only to conduct reconnaissance by stealth, but they were too few too late. MG C. L. Scott

warned in 1942 after observing the British in North Africa that light reconnaissance elements designed primarily for observation were not faring well against Rommel's strong reconnaissance and mobile formations:

...on occasions in the desert, it was not even possible for weak reconnaissance to pause long enough to send in valuable information that had been collected, and it was not unusual to see light, long distance reconnaissance piling pell mell back on the main body just ahead of a strong surprise attack. In this day and age, long distance reconnaissance must be organized to fight in execution of its mission, to fight for time to send information in, and to fight for time for the main body to properly utilize the information sent in.<sup>14</sup>

The divisional reconnaissance squadrons fighting in the Mediterranean and European Theaters were to discover rather quickly the truth of this warning and, even if the written doctrine was slow to change, the reconnaissance squadrons were not slow in adjusting, as best they could, to the requirement to conduct a wide range of missions in addition to reconnaissance and to resort to combat to succeed in those missions. A sampling of those missions reveals their diversity: The 82d Reconnaissance Battalion (2d Armored Division) served as advance and flank guard during its parent division's March-April 1945 exploitation from the Rhine to the Elbe River; the 25th Reconnaissance Squadron guarded the flanks of its parent 4th Armored Division in December 1944 as the Division attacked to relieve the encircled forces at Bastogne; the reinforced 81st Reconnaissance Squadron (1st Armored Division) conducted a raid on the defended town of Cerreto Alto, Italy, in May 1944; the 85th Reconnaissance Squadron attacked to clear towns and forests, and

then often defended what it had seized, during the 5th Armored Division's breakout from the Hurtgen Forest to the Roer River in December 1944; 6th Armored Division's 86th Reconnaissance Squadron exploited in front of the Division following the breakout from the Normandy Beachhead in July 1944; a heavily reinforced 87th Reconnaissance Squadron (7th Armored Division) conducted a deliberate attack to secure crossings of the Moselle River in September 1944; and the 89th Reconnaissance Squadron of the 9th Armored Division delayed the Germans advancing on St. Vith during the December 1944 Battle of the Bulge.<sup>15</sup>

That the divisional reconnaissance squadrons were called upon to perform a wide range of fighting missions during World War II was clearly substantiated by several postwar surveys. One such survey was conducted by the European Theater of Operations (ETO), which convened a General Board in 1945 to examine the tactics and organization used by United States forces in the European Theater. The Armor Section of that Board, headed by BG J. A. Holley, prepared an extensive report on the employment of mechanized cavalry. The Section examined dozens of after-action reports; received input from the field armies; solicited written comments from dozens of senior commanders; held a conference in November 1945 at Bad Nauheim, Germany; and conducted a written survey of combat-experienced armored and cavalry officers. Its findings clearly indicate that the prewar doctrine was flawed, concluding:

- (1) That the mission which was assigned to mechanized cavalry, reconnaissance with a minimum of fighting, was unsound.

- (2) That the mission of mechanized cavalry should be combat.<sup>16</sup>

The Board supported this position by conducting an analysis of the missions performed by eight of the fifteen divisional reconnaissance battalions employed in the European Theater. The Board discovered that reconnaissance was not the primary mission:

<u>Type of Mission</u>	<u>Percentage of Days Conducted</u>
Offense (attack, pursuit, or exploitation)	4
Defense (defend or delay)	11
Security (screen, block, flank protection, fill gaps)	24
Reconnaissance	13
Special Operations (reserve, rear area security)	48 <sup>17</sup>

The Board further noted that most reconnaissance involved offensive combat, as did many security missions. Other surveys confirm the validity of these figures. In 1949, the Army Field Forces Advisory Panel on Armor (Harmon Board) conducted a survey of World War II reconnaissance-unit leaders that yielded the following:

<u>Type of Mission</u>	<u>Percentage of Days Conducted</u>
Reconnaissance	4
Security (rear area, flank guard, covering force, rear guard, or counterreconnaissance)	41
Combat (offensive and defensive)	55 <sup>18</sup>

The even lower percentage of time spent on reconnaissance missions in the Harmon Board figures is because all reconnaissance



units, not just divisional squadrons, were included in the survey. (Reconnaissance units in the cavalry groups of World War II conducted even more fighting and less reconnaissance than their counterparts in the divisional squadrons.)<sup>17</sup> Also, the Harmon Board placed reconnaissance missions involving combat in the "combat" category, rather than the "reconnaissance" category.

In 1953, an Armor Officers Advanced Course Research Committee conducted a similar survey of reconnaissance platoon missions. (Both divisional and nondivisional platoons were included.) The survey covered the period of World War II, the Korean conflict, and the years between. Again, the results are similar:

<u>Type of Mission</u>	<u>Percentage of Days Conducted</u>
Reconnaissance without combat	6
Reconnaissance involving combat	22
Security	36
Combat (offensive and defensive)	36 <sup>20</sup>

As evidenced by these various studies, reconnaissance was not the primary mission of any reconnaissance unit, divisional or otherwise, during World War II. Nor were reconnaissance units often able to avoid combat in the conduct of reconnaissance or of most other missions. Given that the divisional reconnaissance squadron was organized and equipped to engage in only "light" combat, it is little wonder that most World War II commanders wanted to see that organization changed. While specific recommendations varied, they

were almost unanimous in claiming that the squadron needed a more powerful tank-killing gun, more armor protection, and reorganization. The ETO General Board's study recommended the addition of a dragoon troop (mechanized infantry company) to the cavalry squadron and of an infantry squad to each reconnaissance platoon to offset the lack of dismounted combat power.<sup>21</sup> The ETO General Board also recommended that light armor be put on the 1/4 ton scout jeep; that the 60-mm mortars be replaced with the 81-mm mortar; that the carbine be replaced by the more powerful M1 Rifle; that the 75-mm M8 assault gun be replaced by a 105-mm self-propelled howitzer; that an effective antitank gun be developed for the light tank; and that the armor, armament, and cross-country mobility of the armored car be improved.<sup>22</sup>

Various equipment review boards came to similar conclusions. The Army Ground Forces (AGF) Equipment Review Board (Cook Board), which met on 2 January 1945, noted that:

Combat experience in the current war has demonstrated that the existing mechanized cavalry reconnaissance units have been required to perform frequently every form of offensive and defensive combat. Equipment at present provided has not always been suitable for the mission.<sup>23</sup>

The AGF Board recommended that a full-tracked armored personnel carrier be developed for the cavalry and that, in the meantime, the armored car be given a bigger gun; that the 105-mm M37 assault gun be provided to the cavalry and that this open-topped vehicle be provided with overhead armor; and that the M24 light tank be provided to the cavalry (a relatively new vehicle at that time and

an improvement over the M5 light tank).<sup>24</sup>

The War Department Equipment Board (Stillwell Board) that met on 1 November 1945 made similar recommendations. The Stillwell Board noted that "mechanized cavalry reconnaissance units, in addition to their prescribed role of reconnaissance, will be called upon frequently to perform offensive and defensive combat. Equipment contained herein provides for such contingencies."<sup>25</sup> The Board recommended that the 1/4 ton scout be lightly armored; that the light tank replace the armored car; that the 105-mm assault gun be utilized; and that a full-track armored personnel carrier, mortar carrier, and command vehicle be developed.<sup>26</sup>

Through the addition of mechanized infantry and the provision of combat vehicles with more armor and firepower, cavalry leaders hoped to develop cavalry formations with sufficient firepower, armored protection, and combined-arms capability to accomplish the types of missions they were called upon to perform during World War II with inadequate equipment and insufficient combat power. That the divisional reconnaissance squadron was usually successful in performing those missions despite equipment and organizational shortcomings was primarily the result of frequent, and sometimes substantial, reinforcement by other divisional units. Field artillery and medium tanks (or tank destroyers) were habitually attached to the reconnaissance squadron, and, for more difficult or demanding missions, engineers and armored infantry were also attached.<sup>27</sup>

The requirement for frequent augmentation led the ETO General

Board to recommend that the divisional reconnaissance squadron be organized and equipped as a self-sufficient force that did not require such frequent augmentation: "For employment in the armored division, a self-sufficient mechanized cavalry squadron should replace the present mechanized cavalry reconnaissance squadron."<sup>28</sup> The ETO Board also recommended that the infantry division be provided a similar squadron. (The infantry division at that time contained only a reconnaissance troop.)

The changes desired in the squadron's organization, equipment, and doctrine to convert it from a "sneak-and-peek" reconnaissance force to a combined-arms, combat-capable, multi-mission force are perhaps best summarized by the ETO General Board's recommendation that the "reconnaissance" designation be eliminated in view of the proposed combat role of mechanized cavalry."<sup>29</sup> Armor officers at the first postwar Armor Conference at Fort Knox heartily supported this recommendation, voting 61-0 that the word "reconnaissance" be eliminated from the designation.<sup>30</sup>

Many of these desired changes were incorporated into the 1948 TO&E for the Reconnaissance Battalion (see Appendix D). Although the word "reconnaissance" remained in the designation and the squadron reverted to its 1942 designation of "battalion," the organization nevertheless reflected an increased ability for self-sufficient, combined-arms operations, particularly at the company level. Each reconnaissance company included a light-tank section, an infantry squad, and a support squad with an 81-mm mortar. Scouts remained mounted in unarmored 1/4 ton trucks. This organization

provided better combined-arms combat power than did its 1943 predecessor. Overall tank strength in the battalion increased from 17 to 30 (seven per company and two in battalion headquarters versus the 17-tank F Company in the 1943 organization). The loss of the assault gun troop, however, deprived the battalion of indirect fire support.

Perhaps more significant than the organizational and equipment changes was the change in mission. No longer would reconnaissance be the battalion's primary mission. The 1949 Harmon Board discusses this shift in emphasis from reconnaissance to other missions, notably security:

In the performance of all missions, divisional reconnaissance units almost without exception found that the armored car, MR, equipped with 37-mm gun and its companion 1/4 ton truck, were unable to effectively overcome the type of resistance which the platoon normally encountered. Therefore, their employment on covering force or advance guard missions was generally ineffective unless the platoons were reinforced with tanks. As a result of the above experience, steps were taken at the conclusion of World War II to provide an organization which would furnish sufficient "punch" to permit employment on missions now conceived to be primarily security, followed in order by reconnaissance and light combat.<sup>31</sup>

Postwar doctrinal literature began to reflect this shift. The 1950 FM 17-22, Reconnaissance Platoon and Company, reflected a new emphasis on the reconnaissance unit's ability to perform a variety of missions:

Because of their mobility, balanced fire power, light armor, and multiple means of communication, the reconnaissance platoon and company are capable of adapting themselves readily to any type of situation and of engaging in any type of combat."<sup>32</sup>

The Korean War provided support for the validity of this shift in doctrine. The first piece of supporting evidence is that insufficient reconnaissance forces were sent to Korea, resulting in a serious shortage of units able to perform security and reconnaissance missions. A IX Corps after-action report laments the Corps' lack of reconnaissance assets for screening, guarding, and covering withdrawals:

This unit (reconnaissance unit) has the mobility and firepower to perform such actions. In addition it would have been the ideal unit to perform the reconnaissance in force missions during January 1951 and subsequently. Lack of this unit deprives the Corps daily of vital information of the enemy.<sup>33</sup>

MG James Gavin made the same observation after the war, pointing out that cavalry (reconnaissance) forces were needed in June 1950 to delay the initial North Korean advance, in September 1950 to exploit the success of the Inchon Landing, and in November 1950 to conduct reconnaissance that might have detected the Chinese Army's buildup of 30 divisions in North Korea.<sup>34</sup> But the cavalry was not there--no regimental cavalry (which succeeded the reconnaissance group of World War II) or armored divisions (with their reconnaissance battalions) were ever deployed to Korea.

One reconnaissance organization did play a role in Korea, however--the infantry division's reconnaissance company. This company was organized almost identically to the reconnaissance company of the divisional reconnaissance battalion (see Appendix D). While only a handful of such companies were in combat in Korea, their experiences provide further support for the validity of the post-World War II fighting-cavalry doctrine and reinforce many of the

lessons learned in World War II. First, as in World War II, it was evident that reconnaissance was not the primary mission. An Armor Officer Advanced Course Research Report prepared in 1952 revealed that security missions predominated. The report did not include a formal mission analysis, as did the ETO General Board's report after World War II, but the researchers did question numerous reconnaissance officers and NCOs and did examine a variety of after-action and observer-team reports. The divisions employed their reconnaissance companies as flank guards, as part of a covering force, for screening, and as part of an exploiting force.<sup>35</sup>

A second, by no means surprising, finding was that the unarmored 1/4 ton truck (jeep) was just as unsatisfactory a scout vehicle in the Korean War as it had been in World War II. One reconnaissance company commander explained:

Enemy fire is normally received by the lead vehicle which is usually a scout jeep. There were times when the company had to drive through enemy fire to extricate itself from positions which were untenable--the jeeps were very susceptible to this fire.<sup>36</sup>

Again, as after World War II, the consensus was that more armored protection was needed. An Army Field Forces Observation Team surveyed reconnaissance leaders in June and July 1951 as to the adequacy of the reconnaissance platoon organization, and the almost unanimous response was that the organization was adequate, but that a full-tracked armored carrier should replace the 1/4 ton trucks in the scout and support (mortar) squads.<sup>37</sup> IX Corps after-action notes make the same recommendation:

The armored reconnaissance company should be equipped with a fully enclosed armored personnel carrier. The support squad (mortar) in the reconnaissance platoon should be mounted in an armored personnel carrier instead of two 1/4 ton trucks.<sup>38</sup>

Hence the Korean War further demonstrated the need for an adequately armed and armored, combined-arms reconnaissance force capable of performing a wide variety of missions, most of which involve combat. The lack of sufficient reconnaissance forces in Korea pointed out that no other organization is adequately trained, organized, or equipped to serve as such a fighting-cavalry force.

After the Korean War, the support squad's 81-mm mortar was eventually mounted in a half-track.<sup>39</sup> By 1960, the support squads were given more-powerful 106-mm mortars mounted in modified armored personnel carriers.<sup>40</sup> Not until the advent of the M114 full-tracked, armored reconnaissance vehicle in the early 1960's, however, would the division armored cavalry squadron's scout jeeps finally disappear (see Appendix E). (The "cavalry squadron" designation appeared in the 1960 17-45 series TO&E, thus finally fulfilling the desire of the post-World War II reconnaissance officers to have the term "reconnaissance" dropped from the squadron's designation.)

The need for all divisions, not just armored divisions, to have a cavalry squadron was a recommendation of the ETO General Board, and the inadequacy of a single reconnaissance company in the infantry division in Korea bore this out. In 1960, therefore, a three-troop cavalry squadron was added to the infantry division.<sup>41</sup>



These increases in armor, in armament, and (at least in the infantry division) in size were accompanied by a further doctrinal trend toward multi-mission fighting cavalry. The 1960 FM 17-35, Armored Cavalry Platoon, Troop and Squadron, refers to three types of missions--reconnaissance, security, and economy of force. The squadron "is organized, equipped, and trained to engage in offensive and defensive combat or in retrograde operations in the execution of these missions."<sup>42</sup> The squadron is to be employed as a unit, without detachments, normally under division control, and is expected to perform most missions without attachments.<sup>43</sup>

Hence, by the early 1960's, most of the recommendations regarding equipment, organization, and doctrinal changes for the divisional cavalry squadron had come to fruition--the divisional cavalry squadron had become a largely self-sustaining, combined-arms fighting force capable of performing a variety of missions.

But the zenith of the "fighting cavalry" concept was not yet at hand. In 1964, a common-type armored cavalry squadron was designated for all divisions (armor, mechanized, and infantry). This squadron, with three ground cavalry troops and one air troop (see Appendix E), was an even more potent fighting force. This same organization (TO&E 17-105) would basically remain in effect through the "H series" of the late 1970's. The air cavalry troop, with its aeroscouts, aeroweapons, and aerorifle elements, was the primary contributor to this increase in fighting power. The air troop provided the squadron with even greater flexibility to perform a variety of missions. The fighting capability of this squadron would be tested in Vietnam.

Six divisional cavalry squadrons, not counting the air cavalry squadron of the 101st Airmobile Division, fought in Vietnam.<sup>44</sup> As in previous wars, the cavalry squadrons were tasked to perform a wide variety of missions, of which reconnaissance was but one aspect. Cavalry performed reconnaissance in force--once the enemy was located, mobile ground and air cavalry units then "piled on" the enemy. Another mission was "clear and secure," an operation designed to secure an area from enemy control. Cavalry frequently performed security missions, notably convoy and route security. Cavalry also performed base defense. Finally, making use of its speed and mobility, cavalry frequently served as a ready-reaction force able to arrive quickly at trouble spots with significant organic firepower.<sup>45</sup>

Early in the Vietnam War many senior commanders, including General Westmoreland, then Commander of the Military Assistance Command, Vietnam (MACV), saw no use for mechanized units in Vietnam. General Westmoreland declared in 1965 that "except for a few coastal areas, most notably in the I Corps area, Vietnam is no place for either tank or mechanized infantry units."<sup>46</sup> Based on this misconception, mechanized units were not given high priority on the troop deployment lists. The first U.S. division to deploy, the 1st Infantry Division, was finally permitted, after much debate, to take its armored cavalry squadron, equipped with M48 medium tanks in the tank sections and M113s in the scout sections. (The M113s were taken in lieu of the mediocre M114.)<sup>47</sup> This squadron, the 1st Squadron, 4th Cavalry, was the only mechanized unit in the

division. It quickly proved its worth and dispelled the myth that mechanized forces were inappropriate for use in Vietnam. The ground cavalry troops, fighting mounted in their M48 tanks and modified M113 Armored Cavalry Assault Vehicles (ACAVs), often responding to enemy forces initially discovered by the air cavalry troop, were found to be the most effective combined-arms force available to the division commander.<sup>46</sup>

The 1967 Mechanized and Armor Combat Operations in Vietnam (MACOV) Study settled once and for all the question of the value of mechanized forces in general, and of armored cavalry in particular, as a combat force in Vietnam. The study noted that cavalry units were increasingly used as combat forces for purposes other than traditional reconnaissance and security:

Armored cavalry units...are being increasingly assigned to those roles previously assigned to armor and infantry combat maneuver battalions rather than being restricted to the traditional reconnaissance and economy of force roles.<sup>47</sup>

By the late 1960's, troop deployment lists reflected a far greater percentage of mechanized forces than was originally planned. In addition, some in-country units were being converted to mechanized infantry. At least one officer proposed that more cavalry squadrons be added to the infantry division:

...the much greater firepower and versatility of the armored cavalry squadron compared to the infantry battalion, mechanized infantry battalion, and tank battalion make it the most effective and economical maneuver unit for use in the infantry divisions in the 2d Field Force, Vietnam, zone.<sup>50</sup>

In essence, during Vietnam, the division's armored cavalry squadron was used not only as a cavalry force to perform reconnaissance and security missions, but also as a maneuver force to perform the same types of offensive and defensive missions normally assigned to infantry and armor battalions. MG (now GEN) Starry, however, in a post-war study of armor in Vietnam conducted when he was Commandant of the Armor School, properly reminded everyone that the traditional cavalry role should not be forgotten:

That armored cavalry units in Vietnam were widely used as combat maneuver forces should not be allowed to obscure the fact that they are still a part of the central core of the reconnaissance team. The air cavalry-ground combination can give a much needed advantage to the force commander who uses it wisely.<sup>51</sup>

Apparently General Starry's warning was heeded, for post-Vietnam doctrine on the employment of cavalry did not change, despite the successful use of the divisional cavalry squadron in Vietnam as a combined-arms maneuver battalion. Its doctrinal role remained that of a reconnaissance, security, and economy-of-force unit. One side effect of cavalry's success as a combat force in Vietnam, however, was an even greater emphasis in doctrinal literature on the use of combat as a means of fulfilling those three traditional roles. The 1977 FM 17-95, Cavalry, made the clearest statement yet on the need for cavalry to fight to accomplish its mission:

Cavalry's basic tasks are reconnaissance and security. Cavalry accomplishes these tasks through combined arms action at all levels.... Cavalry moves to see and moves to fight. When fighting outnumbered, it is necessary for any force of combined arms to move to mass sufficient force to accomplish its mission. This more so with cavalry than with other forces, since one of

cavalry's prime tasks is to find the enemy and fight him.<sup>52</sup>

Several organizational and equipment changes occurred following Vietnam, most of which better allowed the divisional cavalry squadron to fulfill its role as fighting cavalry. The light tank was replaced by the M551 Sheridan or by the M60-series main battle tank to provide more firepower to the platoon. The tank section was increased in size from two to three and eventually to four tanks.<sup>53</sup> The support squads were consolidated at troop level into a three-tube mortar section to provide the troop commander with more centralized indirect fire support, although the support squads retained the capability of operating separately with each cavalry platoon. The M114 scout vehicle was given a 20-mm cannon to increase its firepower. This rather mediocre vehicle was eventually replaced, however, by the more reliable M113. The M113 scout vehicle carried TOW and Dragon antitank missiles, thus considerably increasing the scout section's firepower.

One change on the negative side involved the elimination of the infantry squad from the cavalry platoon. The 1945 ETO General Board had recommended the addition of an infantry squad to each platoon and an infantry company (dragoon troop) to the squadron. Only the first part of this recommendation was ever carried out, however, and dismounted fighting strength in the divisional cavalry squadron therefore remained inadequate. The 1973 EUROCAV Study recognized this shortfall, but then made the rather amazing recommendation to eliminate what infantry strength was available:

The organically assigned infantry squad...has been eliminated. One squad was found to be ineffective in support of most platoon missions. To be viable, additional infantry squads would have to be added to each platoon and this was considered infeasible in light of personnel constraints and the platoon leader's span of control.<sup>54</sup>

Except for this elimination of the infantry squad from the cavalry platoon, up until the late 1970's virtually every change made to the divisional cavalry squadron since World War II had served to increase its combat power and versatility. The experiences from three wars supported this trend and the pre-World War II concept of a lightly armed and armored squadron capable of only reconnaissance and "light" combat was never revisited--that is, until 1980.

### III. Division 86 and the Doctrinal About-Face:

#### Return to "Sneak and Peek" Reconnaissance

The primary function of the reconnaissance battalion is the gathering of information, both positive and negative, and the prompt transmission of this information to the division commander. The reconnaissance battalion as a general practice seeks to avoid combat.... It is essential that the battalion does not become so involved in combat that it will require the use of other units in the division to extricate it.<sup>55</sup>

FM 17-10, 1942  
Armored Force Tactics and Techniques

The principal mission of the divisional cavalry squadron is reconnaissance....<sup>56</sup>

"Operational and Organizational Concept  
Division and Corps 86 Cavalry," 1980

Division cavalry must avoid decisive engagement. Cunning, an awareness of the tactical situation, stealth, and maneuver using proper techniques of

movement and overwatch help prevent the divisional cavalry from being decisively engaged.<sup>57</sup>

FM 17-100  
Divisional Cavalry Squadron  
Current Working Draft

In 1960, as part of the Division 86 restructuring, the 35-year trend toward a fighting, multi-mission capable cavalry squadron abruptly halted. In its place emerged a new organization emphasizing, much like its pre-World War II ancestor, reconnaissance using stealth. The organization of this squadron, as only slightly modified by the Army-of-Excellence (AOE) Study that followed the Division 86 Study, is shown at Appendix F. A comparison between the AOE squadron and its TO&E 17-105 H-series predecessor illustrates just how much the divisional cavalry squadron has been "lightened."<sup>58</sup>

	<u>H Series</u>	<u>AOE</u>
strength	862	613
tanks	36	0
scout helicopters	10	12
ground scout vehicles*	45	36
attack helicopters	9	8
mortars	9	6

\*Only those M113s/Cavalry Fighting Vehicles (CFVs) of the cavalry/scout platoons; i.e., those vehicles which fulfill the actual scouting role, are included.

A comparison of capabilities between the AOE Squadron and its H-series predecessor also reveals a strong shift away from missions requiring combat:<sup>59</sup>

H-Series Capabilities

reconnaissance (route,  
zone, area, NBC, aerial)

screen

AOE Capabilities

reconnaissance (route,  
zone, area, NBC, aerial)

screen

H-Series Capabilities

AOE Capabilities (cont.)

guard	facilitate command and control of the division commander
attack	conduct line of communication surveillance and assist troop movement within the division area
defend	
delay	
rear area security	position and monitor remote sensors
cover (as part of a larger force)	conduct internal surveillance to facilitate rear battle

The rationale for this fairly radical shift in doctrine and organization is not readily apparent. The only explanation accompanying the October 1980 "Organizational and Operational Concept" is that the corps' armored cavalry regiment (ACR) would perform any necessary economy-of-force missions within the corps area, thus making tanks unnecessary in a divisional squadron that no longer had to perform such economy-of-force missions.<sup>40</sup> Some division commanders, especially in United States Army Europe (USAREUR), and many concerned senior cavalrymen, are skeptical of this explanation, given the ACR's probable inability to support both corps and divisional economy-of-force missions. As Major Thomas A. Dials, the former Executive Officer of the 3d Infantry Division's cavalry squadron (3-7 Cav) has written:

...the assumption that the heavy division generally will be able to rely on the corps armored cavalry regiment (ACR) to carry out its economy-of-force requirements is questionable. Using this vital corps asset to accomplish divisional missions only "passes



the buck" to the corps commander, who must then pay the flexibility penalty in fighting the corps battle. A far more reasonable assumption is that the corps will retain the ACR to meet its own requirements leaving the division to form its own economy forces.<sup>41</sup>

Another, more likely, explanation for the change in doctrine is that the squadron's organization was changed first, and then the doctrine was developed to fit the new organization. One author hints at this when he notes that "another factor influencing the Chief of Staff's decision was the limited number of tanks and personnel available to equip the required Division 86 force structure."<sup>42</sup> In short, tanks and personnel had to be cut somewhere, and the cavalry squadron was one of the organizations targeted. The AOE study, instituted primarily to identify where further cuts could be made to the Division 86 organizations, only resulted in a slight further reduction in the squadron's strength (see note to Appendix F).<sup>43</sup> Once the tanks were removed, the squadron no longer had the combat power for traditional cavalry economy-of-force missions such as guard, cover, and defend, which by definition could involve decisive engagement, so the doctrine had to be adjusted accordingly.

While it is not certain that this "cart-before-the-horse" approach was, in fact, the way in which the squadron's new doctrine was derived, it is apparent that no deliberate, detailed analysis of the squadron and its missions (such as was done by the ETO General Board in 1945 or by the EUROCAV Study Group in 1973) preceded these doctrinal and organizational changes. Only now are war-gaming analyses being conducted by the Corps Deep Battle Analysis Task

Force at Fort Leavenworth to test the feasibility of the new structure and doctrine and only now, very much after the fact, is the U.S. Army Armor Center at Fort Knox working on a draft doctrinal manual, FM 17-100, Divisional Cavalry Squadron, covering the employment of the AOE divisional squadron.

While this "sneak-and-peek" reconnaissance doctrine was apparently adopted rather hastily to support the radical change in organization, if time had permitted a thorough and reasonable analysis, it would have revealed a fair amount of support among some cavalymen for such a doctrine, as well as a significant amount against it.

#### IV. The Arguments For and Against Fighting Cavalry

For many years some U.S. Army cavalymen have championed the doctrine of reconnaissance by stealth over that of fighting cavalry, and they have presented compelling arguments in favor of their position. One often-heard view argues that cavalry that is fighting is not conducting reconnaissance, and hence, a valuable asset specially trained and organized for reconnaissance is being wasted:

If we arm the scout as a fighter, he is likely to become one. The obvious corollary is that if we provide the senior commander an armor-protected, heavy-firepower, tank-like force, it is likely to be used as one, and at that point the cavalry would cease to accomplish proper reconnaissance and security and become decisively engaged.<sup>64</sup>

Others concur, adding that the artificialities of peacetime maneuvers often permit the division commander to use his cavalry squadron as a maneuver force rather than as a reconnaissance

element. Predetermined exercise areas during maneuvers such as REFORGER tend to create a well-defined, linear area of operations with fixed lateral boundaries. Consequently, the division commanders are not forced to make maximum use of their cavalry squadrons for reconnaissance or security purposes. Instead, "squadrons have...been primarily used as division minicovering forces, and to add significant localized combat power once a major decisive battle is joined."<sup>65</sup> In short, the division commander tends to use his cavalry squadron (at least prior to Division 86) as another maneuver battalion.

A corollary to this argument against fighting cavalry is that scouts who fight may not live to fight, or more importantly to conduct reconnaissance, another day. One scout sergeant lamented the addition of the TOW to the scout vehicle for that reason:

Having a tank-destroying capability presents a terrible temptation, especially when a man sees multiple tank targets in front of him--even if he is supposed to be reporting those tanks rather than fighting them, and may well yield to the temptation. The first TOW that leaves the tube destroys the scout's mission, it may even evoke such a reaction as to cause the scout's rapid death.<sup>66</sup>

Another author similarly warns against wasting cavalry strength in combat actions: "This article does not pretend that cavalry reconnaissance units are 'fire brigades.' Their mission is not to be frittered away in needless combat."<sup>67</sup>

A second argument against fighting cavalry is that a cavalry unit sufficiently armed and armored to stand up to the opposition will, of necessity, lose the traditional cavalry advantage of

superior mobility. One early warning against making this mistake was heard in 1938:

An idea has obtained currency that mechanized cavalry should be able to revive cavalry shock action; and its advocates desire that mechanized cavalry vehicles be fitted with sufficient armor to protect their occupants from fire. A force of heavily armored vehicles could never possess the mobility which must be the distinguishing characteristic of cavalry.<sup>68</sup>

This argument has been repeated frequently since that time by advocates of light, mobile cavalry. A World War II reconnaissance-battalion commander warned against overburdening a reconnaissance unit with weapons: "Beware of that misused word 'firepower.' Don't tie a reconnaissance unit down with tanks, 81-mm mortars, 37 SP guns, because it makes the unit too unwieldy, and few officers can take care of all those additions and still do the job of gathering information."<sup>69</sup>

Some cavalymen dislike the inclusion of the main battle tank in cavalry organizations because it degrades the unit's mobility and stealth, claiming that a fast, light, quiet vehicle is needed for reconnaissance:

Mobility, in every sense of the word, must be the primary consideration for the scout. His vehicle must have excellent cross-country mobility and agility, to include an amphibious capability. Equally, the scout's mount must be silent enough to approach without being detected, and have a low enough profile to present a minimal target.<sup>70</sup>

Thus proponents of reconnaissance by stealth argue that fighting detracts from the more important mission of reconnaissance and, furthermore, that such fighting jeopardizes the success, and even

the continued existence, of the cavalry unit. Finally, by providing the cavalry unit with the armor and armament necessary to fight, the cavalry loses its traditional advantage of superior mobility. For these reasons, some cavalrymen are pleased with the AOE divisional cavalry squadron's return to a doctrine of reconnaissance by stealth and with the exclusion of tanks from the organization, the absence of which enhances mobility and forces the division commander to emphasize reconnaissance over fighting if only because the squadron is no longer equipped for decisive engagement.

On the other hand, advocates of fighting cavalry reject the arguments posed by those favoring reconnaissance by stealth and pose several arguments of their own as to why cavalry should be a multipurpose force capable of fighting. Supporters of fighting cavalry reject the argument that cavalry units that are fighting are not conducting reconnaissance and, as such, are being wasted. Fighting, reconnaissance, and security are not mutually exclusive activities. Reconnaissance often develops into combat, and this is not necessarily wrong:

As hostile resistance becomes stronger and security patrols more aggressive, reconnaissance enters the combat phase. Reconnaissance units engage in combat for two main reasons: either to develop an obscure position--force the enemy to show his hand--or to break through a hostile security screen so that reconnaissance may be continued deep into enemy controlled territory.<sup>71</sup>

Similarly, reconnaissance is a constant implied mission for cavalry even when conducting security or combat missions. The ETO General Board noted this trend in World War II: "Reconnaissance was

frequently performed by mechanized cavalry units but usually in conjunction with the execution of other missions rather than as a mission of its own."<sup>72</sup> In short, distinctions between reconnaissance and fighting tend, in reality, to become blurred.

Fighting cavalry advocates also reject the argument that a cavalry organization heavy enough to fight has lost its mobility advantage. Mobility is more than speed. A vehicle with superior speed can obviously be designed by sacrificing armor and size, as some countries have done. But, just as with the lightly armored U.S. tank destroyer of World War II, superior speed does not mean superior mobility:

Most ironically, the super-mobile tank destroyer weapons were found to be lacking in tactical mobility. They were often driven to cover and immobilized by enemy fire that posed no threat to slower but better armored vehicles.<sup>73</sup>

The same was often true of the lightly armored M8 armored cars and M5 light tanks in the World War II divisional reconnaissance squadrons. They were often halted by enemy resistance until heavier medium tanks or infantry support could be brought forward. For example, one reconnaissance troop, as it exploited across France, was repeatedly held up by the same group of antitank guns:

The enemy appeared to be withdrawing his anti-tank weapons shortly after each encounter and setting them up again either on the road leading into the next town, or just on the far side of town. Troop A was pulled off the road...and the medium tanks were again brought up to overrun the guns.<sup>74</sup>

Major General Robert Grow, commander of the 6th Armored Division

in World War II, summed up this mobility problem by noting that the reconnaissance squadron, while faster than the rest of the division, nevertheless lacked tactical mobility: "We could not expect our reconnaissance units to operate freely in front of the main body unless we gave them sufficient armor and armament which would in turn slow them down to the speed of the main body (emphasis added)."<sup>75</sup>

Modern cavalymen are faced with a similar problem. The M3 Cavalry Fighting Vehicle, while possessing excellent speed and cross-country capability, probably will not have a decisive mobility edge over potential opponents, nor over the main body of the division it is working for. Only aggressive combined-arms action can provide such a mobility advantage:

...cavalry retains most of its mobility advantage over other types of units simply through its organization. Scouts and tanks, operating as a team, yield a clearer picture of the battlefield than any other type of unit can obtain. The commander who "sees the battlefield" more clearly, reacts more quickly and maneuvers his forces more effectively to engage the enemy. Cavalry employs scouts to locate the enemy and to determine his strength and disposition, and combined arms in order to fight through or around him. In short, cavalry units gain a mobility advantage because they waste less time developing the situation.<sup>76</sup>

Such fighting-cavalry advocates feel removal of tanks from the AOE squadron would result in a loss, not a gain, in tactical mobility.

In addition to rejecting the arguments of the reconnaissance-by-stealth advocates, the supporters of fighting cavalry put forward a few reasons of their own as to why the squadron should be organized

and equipped to perform a wide range of missions. One reason becomes evident when one considers the relationship of the cavalry squadron to its parent division. Pre-World War II doctrine called for an armored division that was highly mobile and offensively oriented: "It is capable of engaging in most types of ground operations, either as part of a larger force or independently when reinforced. Its primary role is offensive operations in hostile rear areas."<sup>77</sup>

The 1940 armored division was, in essence, a special-purpose division designed for exploitation, and the idea of a light, fast, road-mobile reconnaissance squadron gathering information in advance of the division made some sense. Wartime experience showed the fallacy of this doctrine, of course, resulting in several reorganizations of the armored division to get more medium tanks and more infantry into the structure.

The present armored/mechanized division is not such a "special-purpose" division, but is instead the backbone of the heavy force structure. A strong cavalry squadron, capable of performing a wide range of missions, is therefore needed to match the all-purpose nature of the modern heavy division.

A second reason why fighting-cavalry advocates prefer a strong, multipurpose squadron over the AOE squadron is that they see the AOE squadron as a false economy. While the removal of the tanks from the squadron allowed a shifting of combat power to the division's maneuver battalions, in the long run the division commander may lose more combat power than he gained:



I believe the net effect will be to diffuse combat power throughout the division area of operations. This diffusion will be necessary to compensate for the reduced capability of the cavalry. The weakening of the division's organic economy force is the fundamental flaw in an otherwise impressive war machine.<sup>78</sup>

The only way to prevent this diffusion is to attach additional combat forces to the AOE squadron, notably tanks and possibly mechanized infantry, to allow it to perform the sort of economy-of-force missions it had performed under its H-series organization with primarily organic assets. The need for frequent augmentation to be able to perform most missions was also a chronic problem of the World War II reconnaissance squadron: "Reinforcement of cavalry units with motorized infantry, tank destroyers, artillery, engineers, and tanks was required for accomplishment of most combat missions."<sup>79</sup> Indeed, if such habitual augmentation proves to be required for the AOE squadron, then it must be viewed as false economy.

A problem related to that of frequent augmentation is that of training. Under the current H-series organization, the scouts and tanks are trained to work together and are familiar with the rather specialized requirements for conducting such cavalry missions as screen, guard, cover, zone reconnaissance, etc. Augmentees to the AOE squadron will have no such training advantage. The ability to rapidly integrate such augmentees into the squadron in preparation for a mission could be another problem--a problem not normally faced in the current H-series organization, which rarely has to task organize at the troop level. Such time-consuming task organizing

was a common requirement for the World War II reconnaissance squadron, as exemplified by the 87th Reconnaissance Battalion's receipt of substantial augmentation necessary to conduct an attack: "All columns reported crossing the line of departure...after spending a normally hectic night in organizing forces and teams and establishing communications."<sup>20</sup> The benefit of the current H-series squadron is that it can conduct such an attack without such "hectic" task organizing, a factor that fighting-cavalry advocates say enhances the squadron's tactical mobility.

A final, and possibly most important, reason why fighting-cavalry advocates favor a strong, multipurpose squadron over the AOE squadron is that the AOE squadron may no longer have the capability to overcome enemy reconnaissance and security forces. In the conduct of reconnaissance and screening missions, the divisional cavalry squadron will inevitably encounter Soviet reconnaissance and security elements. To succeed, the squadron must be able to defeat those elements without requiring a great deal of assistance from external forces, and this will mean defeating enemy main battle tanks, for just as the AOE squadron is losing its tanks, the Soviets are adding six tanks to their divisional reconnaissance battalion.<sup>21</sup> Even more ominous, however, is the frequent Soviet use of regular motorized-rifle and tank elements in security zones and for battle reconnaissance (also referred to as "reconnaissance in strength").<sup>22</sup>

While the M3 Cavalry Fighting Vehicle (CFV) of the AOE squadron is armed with a tank-defeating TOW, the latter is a weapon best

employed defensively at long range. During the conduct of reconnaissance, however, contact often occurs at short range between opposing forces, and a quick-firing, tank-defeating gun is much preferred in such circumstances. While the AOE squadron's attack helicopters may prove valuable at this point, weather or terrain may hamper their employment, not to mention that only eight such attack helicopters are available. Consequently, a reconnaissance mission may all too quickly become a hasty defense.

Nor will enemy tanks present the only problem to the AOE squadron. The Soviet rifle squad (either BMP or BTR mounted) dismounts seven personnel. The M3 CFV dismounts only two scouts. An AOE ground cavalry platoon encountering a Soviet motorized rifle platoon in the security zone or as part of a battle-reconnaissance force would have to contend with 21 *dismounted infantrymen* while able to dismount only 12 of its own scouts.<sup>23</sup>

In short, advocates of fighting cavalry are dissatisfied with the AOE squadron not only because it cannot perform such traditional cavalry missions as guard, cover, defend and delay, but also because it will be hard pressed to cope with normal Soviet security and reconnaissance forces which, by organization and doctrine, will include main battle tanks and considerable dismounted fighting capability:

The capability of our current (H-series) armored cavalry organization to defeat the reconnaissance and security elements of any potential adversary is an advantage we should not surrender without careful consideration.... The current armored cavalry organization provides for more than reconnaissance

and warning of enemy movement. It gives the commander the crucial moments required to react to the unexpected thrust. The loss of this capability is a crushing blow to the heavy division."<sup>4</sup>

#### V. Conclusions: The Time and Mission Dilemmas

While the advocates of fighting cavalry present a strong case and while numerous historical precedents support their position, it is important to remember that the "sneak-and-peek" advocates are not incorrect in their basic premise. What all cavalrymen must remember is that cavalry should be able to both fight and scout. COL (now LTG) Crosbie Saint, when commanding the 11th Armored Cavalry Regiment, explained it well in 1977:

The soldier can gain information in a number of ways: he can use stealth, and the information will be gained by such means as reconnaissance, patrols, and observation posts. The soldier should avoid enemy contact and should gain knowledge of the enemy without being detected.... Another way to provide information is by engaging in combat in order to develop the situation. We must remember that when you fight, you have to be able to force the enemy to show his strength and thus to unveil his weakness."<sup>5</sup>

Reconnaissance by stealth is an admirable technique and most scout sergeants, being rational soldiers, prefer it to being shot at, but it is not always possible to use stealth. As then-MG Starry, Commandant of the Armor School, pointed out, much depends on the situation: "Scout tactics range from stealth to fully supported fire and maneuver, depending upon the strength and disposition of the enemy, and the mission of the scout's parent unit."<sup>6</sup> While enemy and mission are important factors, MG Starry failed to mention the most important factor of all--time. Time, or the lack

of it, presents a dilemma to the cavalryman: Stealth is often the best way to conduct reconnaissance, but stealth requires time, and it is time that is most often lacking in war. A pre-World War II reconnaissance battalion commander, while advocating reconnaissance by stealth, had to concede that stealth is not always possible:

When sufficient time is available, the principle of stealth is employed to the maximum advantage and combat is avoided. When time is pressing and division columns are closing on the reconnaissance elements, combat must be resorted to more frequently.<sup>87</sup>

As reconnaissance leaders are quick to point out, proper reconnaissance by stealth involves dismounted activities, but time will frequently be insufficient to allow proper dismounted reconnaissance: "The situation and the mission will often demand that we take the calculated risk of staying on the roads and remaining in the vehicles."<sup>88</sup>

Hence advocates of reconnaissance by stealth must remember that, while their concept is sound, it is not always feasible in a fast-moving battle, in which case cavalry had better be able to fight to obtain information and in self-defense. The AOE squadron, like its World War II counterpart, may have difficulty in resolving this dilemma, because, when time is limited, the squadron has limited capability to resort to combat to complete the mission.

In addition to the time dilemma, the AOE squadron will also face a mission dilemma. As with the World War II reconnaissance squadron, the AOE squadron is intended primarily for limited operations (reconnaissance by stealth and missions of lesser importance

such as screening, LOC surveillance, and C2 enhancement). World War II reconnaissance leaders discovered, however, that while everyone from the division commander on down might be aware that the squadron was designed primarily for limited operations, more specifically reconnaissance, there was no guarantee that the squadron would be used only for reconnaissance.

Such misuse occurred for several reasons. First, as discussed in the section "The Arguments For and Against Fighting Cavalry," the distinction between reconnaissance, security, and fighting becomes very blurred in combat. During World War II, reconnaissance was generally performed in conjunction with other missions. There is no reason to assume that the AOE squadron will not find itself in the same situation, in which case it will need to be able to fight as well as to "sneak and peek."

A second reason for the misuse of the World War II reconnaissance squadron resulted from the failure of senior commanders and staff to understand the squadron's capabilities or the nature of cavalry missions. This often resulted in the reconnaissance squadron being committed to a "reconnaissance" that was beyond the unit's capability, that was not possible in the time allotted, or that involved activities that had little to do with reconnaissance:

Among the many wails arising, all charging that "we are misunderstood, misused," is that of the mechanized cavalry. There is justification for this lament.... Too few G2's and G3's understand that these units are trained for specialized operations. Too few understand what may or may not be demanded of mechanized cavalry.<sup>87</sup>

With the AOE squadron the Army is again establishing a unit designed for "specialized operations." The AOE squadron's H-series predecessor, on the other hand, was a much more balanced, multi-purpose organization. As such, the H-series squadron could survive the "abuse" of being misunderstood and misused--the fragile AOE squadron may not.

A final reason for the misuse of the World War II reconnaissance squadron was that, when the division got into a tight spot, the division commander could not afford to hold the squadron back for use only in specialized operations. As one World War II cavalry officer pointed out, a higher commander is more likely to use, rather than hold back, an asset--even if it was not designed for the purpose to which it is committed:

The solution lies either in restricting the type of mission to be given cavalry troops, or in changing the organization so that it is better prepared to accomplish a job of average difficulty. Experience proved that the latter is more realistic, because few high commanders can afford to hold cavalry troops for specialized missions only.<sup>70</sup>

The post-World War II ETO Board came to the same conclusion, and the divisional cavalry squadron was strengthened and reorganized to "accomplish a job of average difficulty." The AOE squadron, however, is a return to the "specialized" reconnaissance squadron of World War II. As such, the AOE squadron will face the same sort of time and mission dilemmas as did its World War II counterpart. One can only wish it the best of luck. Perhaps it is time to reconsider the H-series cavalry squadron.

APPENDIX A

Reconnaissance Battalion (Armored)  
10 July 1940

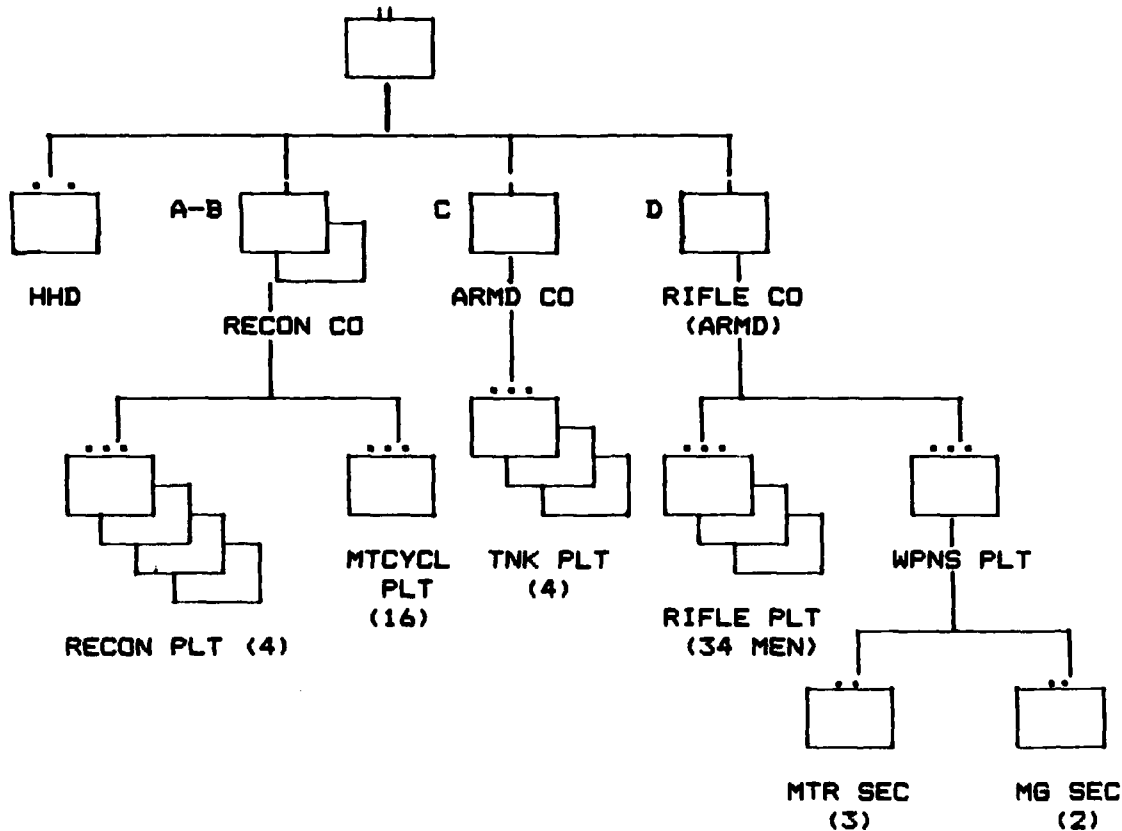

**EQUIPMENT:** The recon company's recon platoons were mounted in scout cars (lightly armored). The motorcycle platoons had a mix of motorcycles and 1/4 ton trucks (Bantams). The tank company had light tanks (probably M3s), and the rifle company was mounted in half tracks. The weapons platoon of the rifle company had three 60-mm mortars and two .30-cal machineguns. The half-tracks mounted .30-cal machineguns as well.

**NOTE:** This organization was part of the first armored division T/O. No unit entered World War II under this T/O. Existing recon battalions had transitioned to the 1942 T/O prior to entering combat.

**SOURCE:** "The Armored Force, Reconnaissance Battalion, Armored Division," The Cavalry Journal, MAJ I. D. White, May-June 1941.



APPENDIX B

Armored Reconnaissance Battalion  
T/O 17-35  
1 March 1942

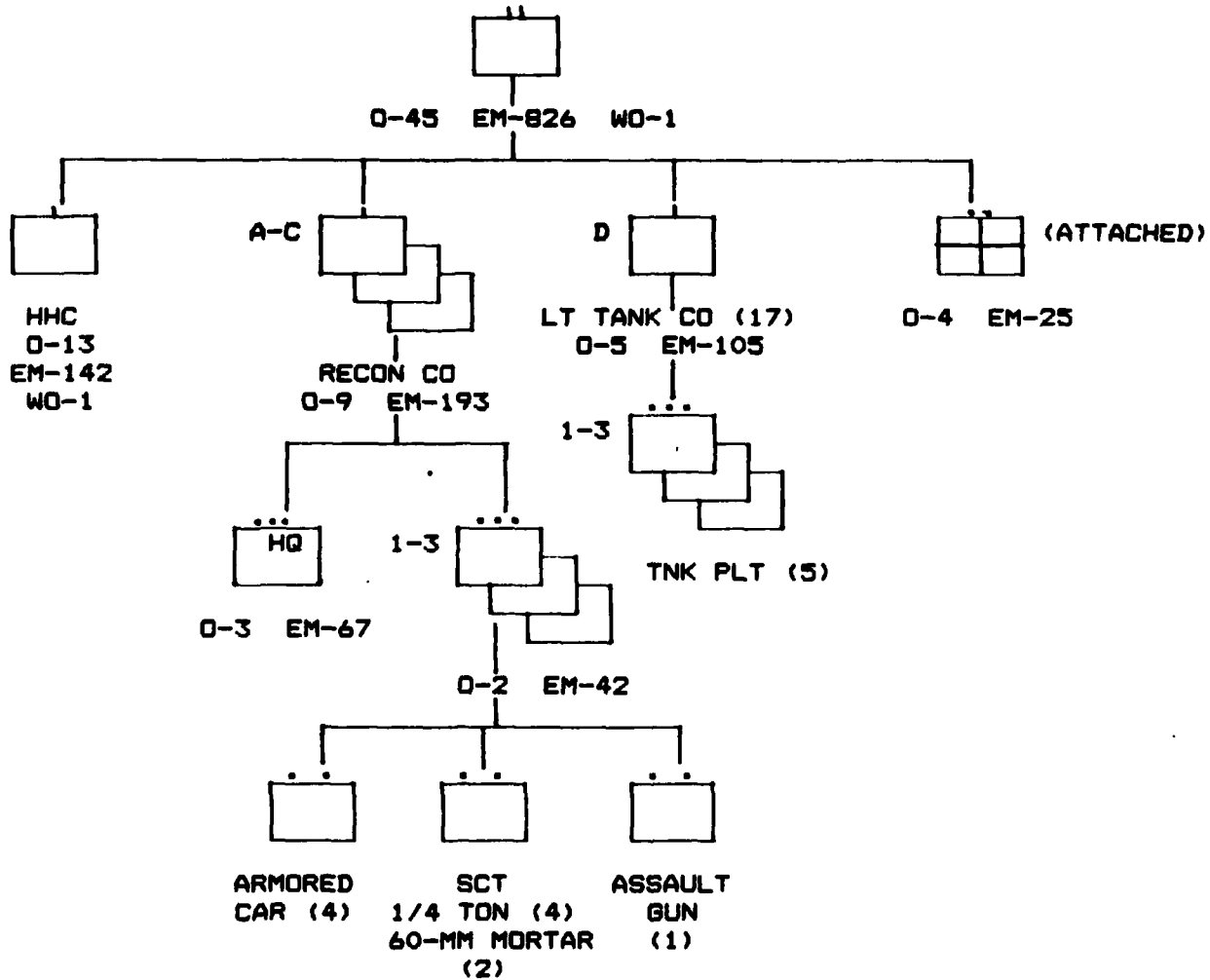

**EQUIPMENT:** Armored cars in the recon platoons were MB Greyhounds (37-mm, 6X6), scouts were mounted in armored 1/4 tons (carrying either a pedestal-mounted MG or a 60-mm mortar), the light tank was the M3 or M5 (37-mm), and the assault gun was the M3 half-track w/75-mm gun (until the MB tracked assault gun w/75-mm howitzer was available).

**NOTE:** The 82d Recon Bn (2 AD) and the 83d Recon Bn (3 AD) remained in this organization throughout the war. All other divisional battalions converted to the 1943 T/O 2-25 by the end of 1943.

**SOURCE:** Operation of the Cavalry Reconnaissance Squadron Integral to the Armored Division, Fort Knox Research Report, May 1950.

APPENDIX C

Cavalry Reconnaissance Squadron  
 T/O 2-25  
 15 September 1943

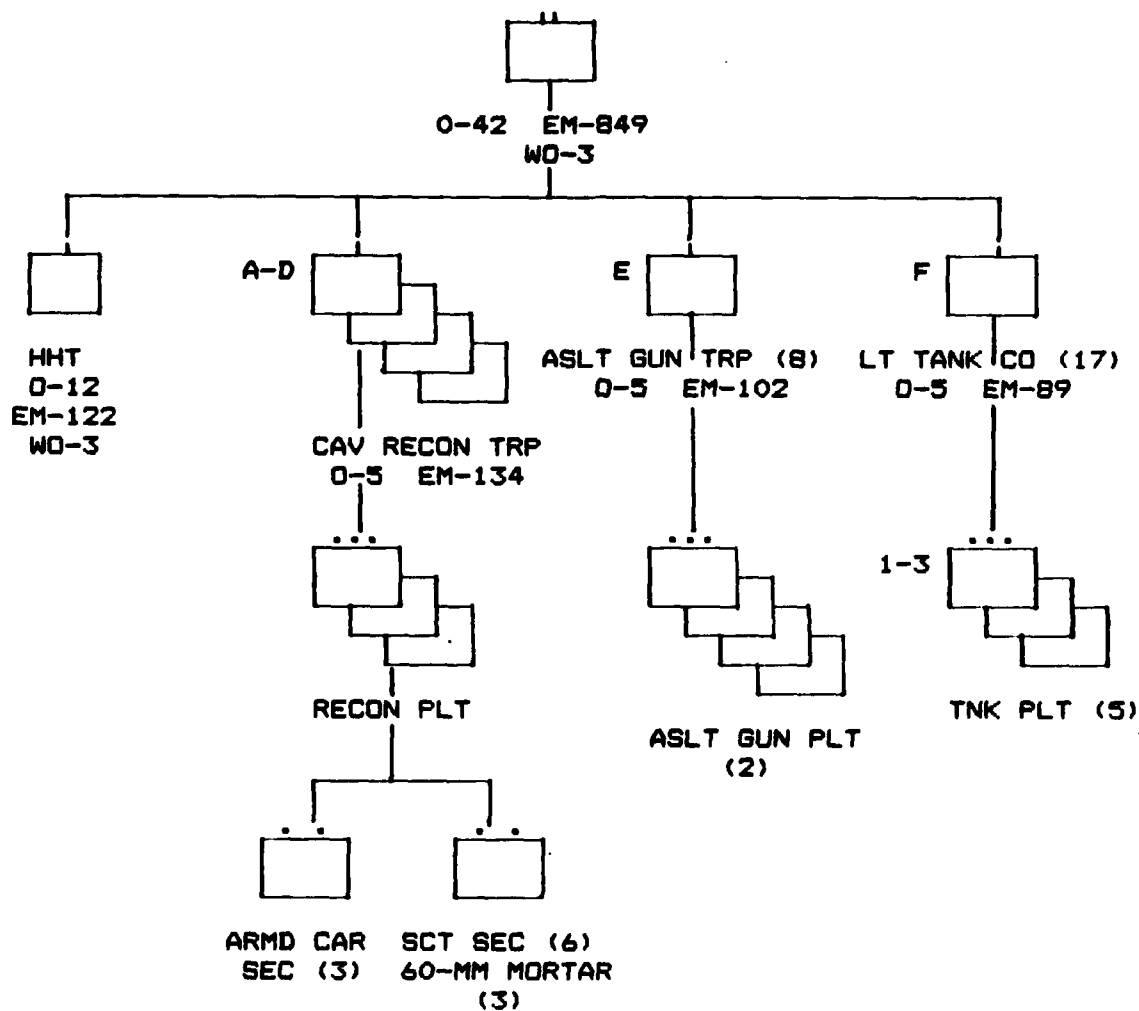

EQUIPMENT: M8 armored cars (37-mm) remained the mainstay of the armored car sections. Jeeps (1/4 ton w/ either a pedestal-mounted machinegun or a 60-mm mortar) remained the scout vehicle. The M5 (37-mm) was the light tank in the tank company, although by the end of World War II, the M24 (75-mm) was making its appearance. The M8 (75-mm howitzer) was the assault gun, although in a few units the M45 (105-mm) made its appearance.

SOURCE: Operation of the Cavalry Reconnaissance Squadron Integral to the Armored Division, Fort Knox Research Report, May 1950.

APPENDIX D

Reconnaissance Battalion  
 TO&E 17-45  
 14 May 1948

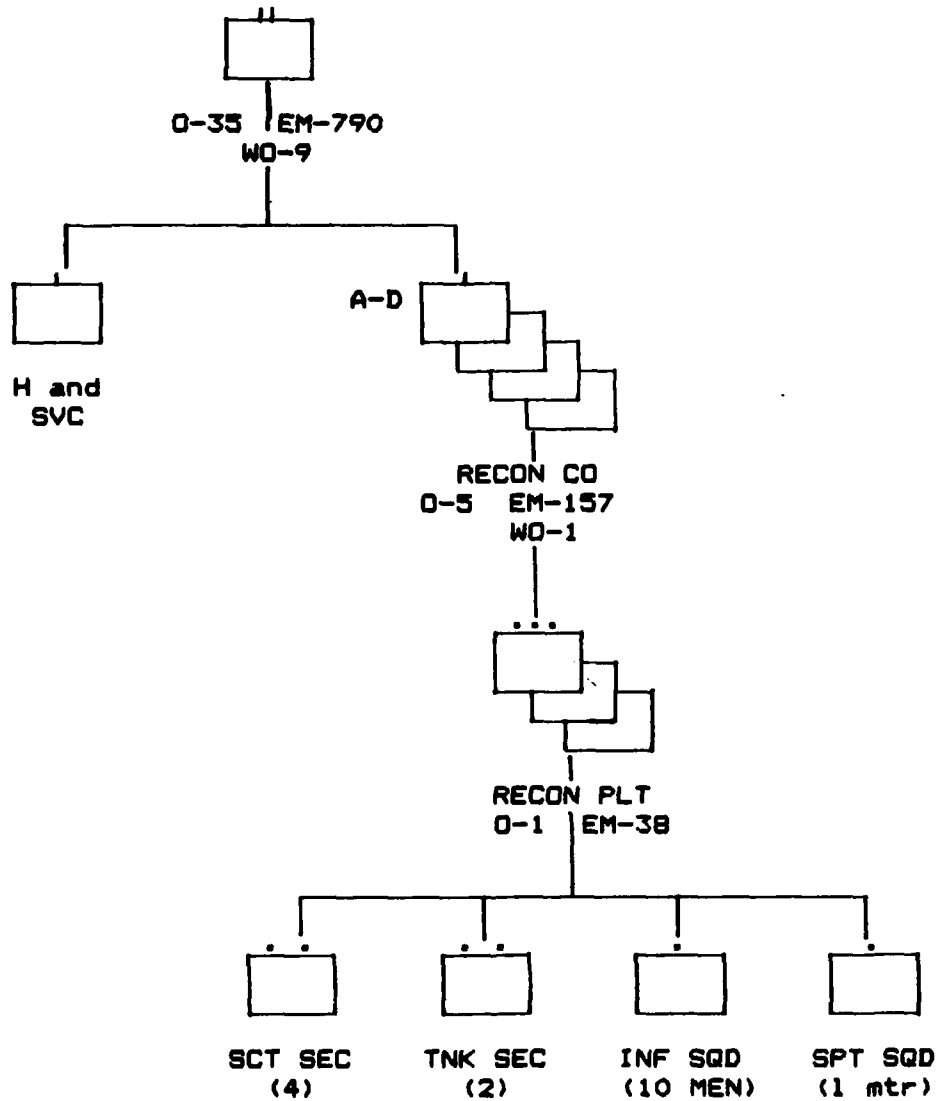

**EQUIPMENT:** The scout section is mounted in 1/4 ton jeeps, the tank section has two M24s (75-mm) or two of the newer M41s (76-mm), the rifle squad is mounted in an M59 APC, and the support squad has 81-mm mortar and two 1/4 tons. The support squad 1/4 tons were later replaced by a half track and eventually by an APC.

APPENDIX D (continued)

NOTE: (1) The names have again changed; in 1940 and 1942 it was "recon battalion." In 1943 it was "cavalry squadron," and now it is back to "battalion." The 1960 version of this T/OE changes the name to "armored cavalry squadron," a name that has remained until the present.

(2) The 1960 TOE 17-85D provided a cavalry squadron to the infantry division. Previously, infantry divisions had only a recon company. The infantry division cavalry squadron had only three troops, instead of four as in the armored division.

SOURCES: The Need for a Lightly Armored Vehicle in U.S. Reconnaissance Units, Fort Knox Research Report, May 1952; Reference Data for Armored Units, Fort Knox, March 1956 and September 1960.

APPENDIX E

Armored Cavalry Squadron  
T/O&E 17-105  
June 1964

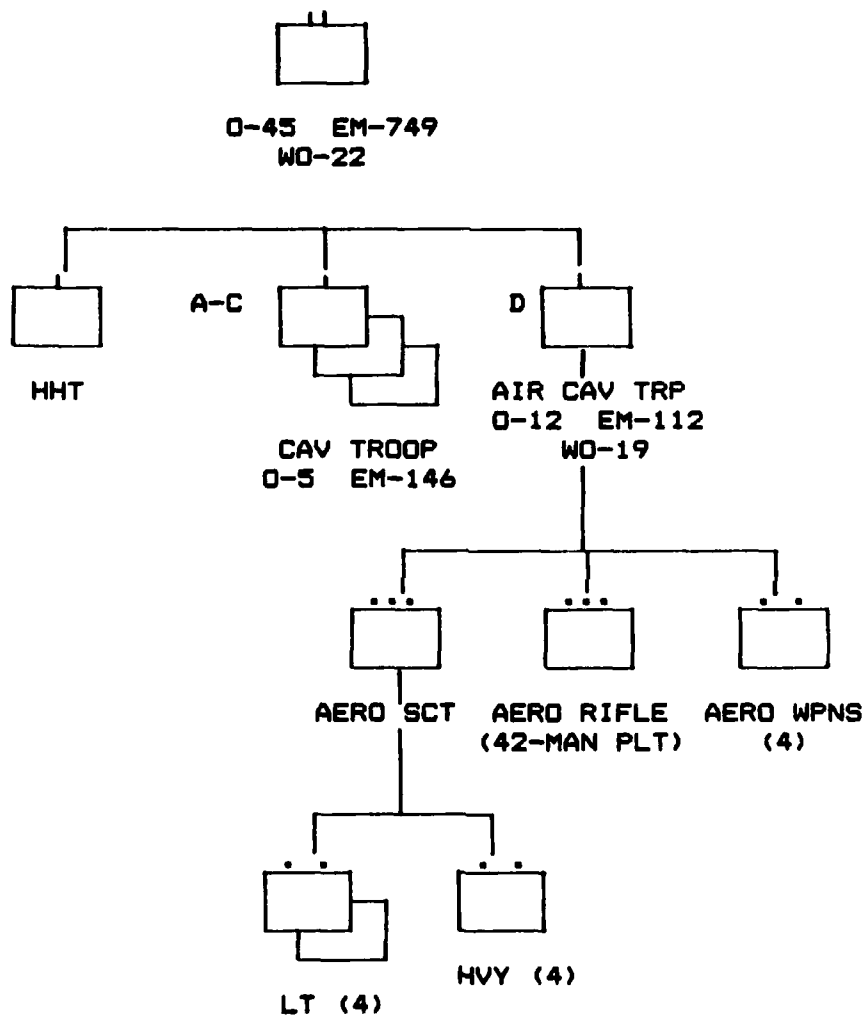

**EQUIPMENT:** The ground cavalry troop remained similarly organized as in the 1948 T/O&E, with the addition of a ground surveillance radar section. The scout 1/4 ton was replaced with the M114. The air troop contained four light observation helicopters in each light observation section (Sioux) and four UH-1s in the heavy observation section. The aerorifle platoon contained a 42-man infantry platoon and five UH-1s. The aeroweapons section had four UH-1B gunships.

APPENDIX E (Continued)

NOTES: (1) As part of the 1963-64 Reorganization of the Army Division (ROAD), the divisional cavalry squadron was established at three ground troops and one air troop, and all armored, mechanized, and infantry divisions had one such squadron organic.

(2) The OH-6 would replace the Sioux observation helicopter late in the 1960s. Also in the late 1960s, the M551 would replace the M41 light tank, and a third M551 would be added to each cavalry platoon. (Some units had medium tanks, M48 and later M60-series, in their tank sections.)

(3) In the early 1970s, the AH-1 Cobra replaced the UH-1 gunship and the aeroweapons section would be increased to a nine-ship platoon. Also, the heavy aeroscout section was deleted from the organization.

(4) The "H" series of this T/O&E is the one under which most divisional cavalry squadrons are currently organized. Changes in the mid-to-late 1970s saw the deletion of the infantry squad from the cavalry platoon, replacement of the M114 by the M113 series, replacement of the M551 by the MBT, elimination of the aerorifle platoon (after going through a brief phase organized as an aerorrecon platoon with 19Ds instead of 11B MOS), and an increase from three to four MBTs in each tank section.

SOURCES: Armor Reference Data, June 1964 and 1978-79; FM 17-36, Divisional Armored and Air Cavalry Units, November 1968 and June 1973.

APPENDIX F

Armored Cavalry Squadron  
 TOE 17206J410  
 10 January 1984  
 (Army of Excellence)

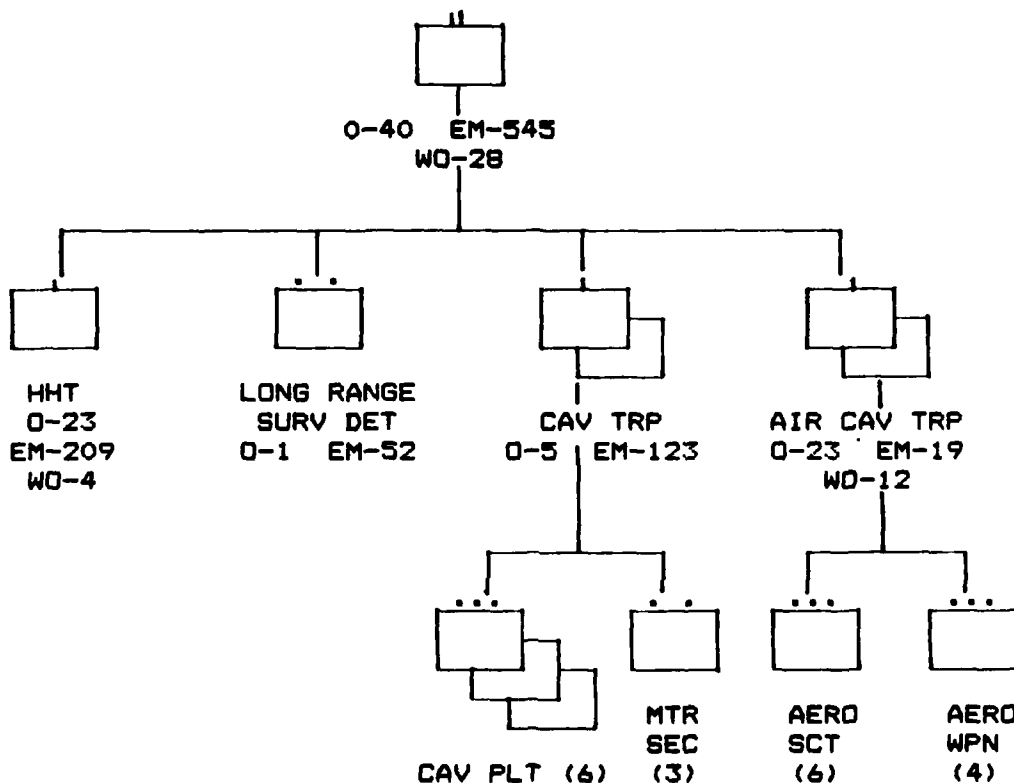

**EQUIPMENT:** Each cavalry platoon has six M3 CFVs (plus one per troop headquarters and two in squadron headquarters making a total of 40). The mortar section has three 4.2" mortars in M106 carriers. The air cavalry troop's aeroscout platoon has six OH-58s and the aeroweapons platoon has four AH-1s.

**NOTE:** The Division 86 version of this squadron (as approved in August 1980 by the CSA) included a motorcycle platoon (13 motorcycles), an NBC recon platoon (with nine M113s), and a sensor platoon (with three REMS teams in M113s). Under AOE, these organizations were deleted and the long-range surveillance detachment was added (located in the CEWI battalion under Division 86).

**SOURCES:** Operational and Organizational Concept, Division and Corps 86 Cavalry, Fort Knox, October 1980; Field Circular 71-8, AOE Close Combat Heavy Brigade and Divisional Cavalry Squadron Organizations, October 1984.

## ENDNOTES

1. Mary Lee Stubbs and Stanley Russell Connor, Armor Lineage Series: Armor-Cavalry, Part I (Washington, DC: 1969), p. 52.
2. Ibid.
3. Field Manual 100-5, Field Service Regulations, Operations (Washington, DC: 1941), p. 258.
4. Field Manual 100-5, Field Service Regulations, Operations (Washington, DC: 1944), pp. 8-9.
5. Stubbs and Connor, p. 72. For a short history of the 26th Cavalry and its determined delaying action against the Japanese invaders of the Philippines in 1941, see Captain Jeffery W. Woodhall, "The 26th Cavalry in the Philippines," Armor (January-February 1983), pp. 8-16.
6. Field Manual 100-5, 1944, pp. 9-10. Not until after the war would a formal recommendation be made by the European Theater of Operations (ETO) General Board that the traditional horse-cavalry missions be assigned instead to the "mechanized cavalry," as the reconnaissance units had come to be known (See ETO General Board Report Study #49, p. 20).
7. The fourteen armored divisions organized (or reorganized if originally activated under the 1942 configuration) under the 1943 "light division" organization were the 1st, 4th through 14th, 16th, and 20th. For a more thorough discussion of the formation and subsequent reorganization of the armored division and its reconnaissance battalion, see "Operation of Cavalry Reconnaissance Squadron Integral to the Armored Division," ADAC Research Report #17, May 1950, pp. 19-26 and Appendix I; Mildred Hanson Gillie, Forging the Thunderbolt (Harrisburg, PA: 1947), Chapters 8-12; and Mary Lee Stubbs and Stanley Russell Connor, Armor Lineage Series: Armor-Cavalry, Part I (Washington, DC: 1969), pp. 58-63.
8. The term "reconnaissance squadron" will be used generally to include both the reconnaissance battalions of the 1942 organization and the cavalry reconnaissance squadrons of the 1943 organization.
9. Field Manual 17-10, Armored Force Field Manual Tactics and Techniques (Washington, DC: 1942), p. 30.
10. Ibid., pp. 277-278.



11. MAJ I. D. White, "The Armored Force Reconnaissance Battalion, Armored Division," The Cavalry Journal (May-June 1941) p. 51. Later-MG I. D. White's comments to the ETO General Board in 1945 are revealing in the extent to which his opinion regarding employment of mechanized cavalry has changed: "There should be no limitations placed on the type of mission given the cavalry mechanized unit. We should...teach that aggressive action generally requiring combat is the best way to obtain information of the enemy (See ETO General Board Report Study #9, Appendix 10, p. 2)."
12. LTC H. H. D. Heiberg, "Armored Reconnaissance," The Cavalry Journal (May-June 1942), p. 70.
13. The exploits of the 81st Reconnaissance Battalion in Tunisia are described in "Cavalry Reconnaissance No 1 and 2, Factual Narratives" prepared by the Cavalry School (undated).
14. MG C. L. Scott, "Armored Reconnaissance," The Cavalry Journal (November-December 1942) p. 21. MG Scott made note of Rommel's use of strong reconnaissance formations: "In this machine age where an enemy like Rommel throws out equally mobile stronger packets of all arms to execute security missions, and where his main elements are equally as mobile as opposing reconnaissance, it is apparent that weak reconnaissance can get nowhere on its mission against this much stronger opposition." (p.21). While this monograph focuses on U.S. reconnaissance doctrine, it is interesting to note that the reconnaissance battalions of the panzer divisions were always intended for use in combat: "The German reconnaissance units were trained and designed not only to obtain information by stealth, but also to take it by force if necessary. The purpose of the reconnaissance units was, therefore, to gain local superiority in the area to be reconnoitered and then to maintain continuous observation. They expected and were prepared to fight to obtain the desired information." (See German Army Panzer and Panzer-grenadier Division 1943-1944, Lee Niehorster, Brooklyn, NY: 1982, p. 31). The panzer reconnaissance battalion got heavier as the war progressed, using larger, more heavily armed and armored wheeled reconnaissance cars, armored assault guns, half-tracks, and light tanks. The battalion included two companies of armored cars; two reconnaissance companies which were, in essence, half-track mounted infantry; and a heavy reconnaissance company that was fully armored and included assault guns, antitank guns, mortars, and engineers. The battalion had a complement of about 942. (See TM-E 30-451, Handbook on German Military Forces, 15 March 1945, pp. II-83 to II-84; German Army Panzer and Panzergrenadier Divisions 1943-1944, 1982, pp. 13 and 31; and H. Scheibert, Panzer-grenadiere, Krad-schutzen, und Panzer-Aufklarler 1935-1945, Hanau, FRG, pp. 122-154.)

15. These engagements are described in greater detail in "Operations of Cavalry Reconnaissance Squadrons Integral to the Armored Division," AOAC Research Report #17 (May 1950), Chapters 4 through 9.
16. "Tactics, Employment, Technique, Organization, and Equipment of Mechanized Cavalry Units," The General Board, United States Forces, European Theater, Study #49, 4 February 1947, p. 20.
17. General Board, USFET, Study #49, Appendix 4, p. 2.
18. "Report of the Army Field Forces Advisory Panel on Armor, Volume II," 18 February 1949, Annex B, Tab 2, p. 1.
19. The General Board separately surveyed the missions conducted by twelve reconnaissance groups and one separate squadron. (Reconnaissance groups were field army formations usually consisting of two reconnaissance squadrons. They were habitually attached to corps or, on occasion, to divisions.) The mission breakout was: offense, 10.2%; defense, 32.8%; reconnaissance, 3.3%; security, 24.9%; and special operations, 28.8% (see General Board, USFET, Study #49, Appendix 3, p. 2.)
20. "The Heavy Reconnaissance Vehicle for the Reconnaissance Platoon," AOAC Research Report by Committee #5 (April 1953), pp. 15-18.
21. General Board, USFET, Study #49, p. 15. The Board discovered that a significant amount of the combat conducted by mechanized reconnaissance units was performed dismounted. (Or more accurately, combat involved a combination of dismounted and mounted action.) The Board's survey of reconnaissance groups indicated that 63.9% of those days the groups were in combat were primarily dismounted action-- only 36.1% of combat days were primarily mounted (See General Board, USFET, Study #49, appendix 3, p. 8). LTC Hoy, commanding the 81st Reconnaissance Battalion during World War II, describes the dilemma this posed for the platoon leader: "Although mechanized cavalry's odometers have recorded thousands of combat miles, more shoes than tires have been worn out. Cavalrymen actually have spent, and will continue to spend, more hours in dismounted than in mounted phases.... To accomplish his (dismounted) missions, the platoon leader has had to use mortarmen and drivers as riflemen.... Only in 'ideal situations' can this be done successfully, and combat seldom presents ideal situations" (LTC Charles J. Hoy, "Trends in Mechanized Cavalry," The Cavalry Journal, July-August 1945, p. 58).
22. Ibid., pp. 15, 17-19, and 20-22.

23. Army General Force Equipment Review Board, Part 1, "Report of Board of Officers Convened to Study the Equipment of the Post-War Army," (20 June 1945), Annex F, p. 1.
24. Ibid., pp. 2-3.
25. "Report of the War Department Equipment Review Board" (19 January 1946), p. 20.
26. Ibid., pp. 20-21.
27. General Board, USFET, Study #49, Appendix 4, p. 3.
28. Ibid., p. 21.
29. Ibid., p. 17.
30. "Conference Conclusions to Agenda for the Armored Conference" (22 May 1946), p. 0-16.
31. "Report of the Army Field Forces Advisory Panel on Armor, Volume I," 18 February 1949, Section V, pp: 4-5.
32. Field Manual 17-22, Reconnaissance Platoon and Company (Washington, DC: 1950), p. 3.
33. Headquarters IX Corps Combat Note #4 (8 August 1951), p. 8.
34. MG James M Gavin, "Cavalry, and I Don't Mean Horses," Armor (May-June 1954), pp. 18-19.
35. "The Need for a Lightly Armored Vehicle in U.S. Reconnaissance Units," Armor Officer Advanced Course Research Report, Committee #38 (May 1952), pp. 74-84.
36. Ibid., p. 81.
37. Ibid.
38. Headquarters IX Corps Combat Note #7 (20 October 1951), p. 8.
39. "Reference Data for Armored Units," the Armor School (March 1956), p. 48.
40. "Reference Data for Armored Units," the Armor School (September 1960), p. 70.
41. Ibid., pp. 60 and 182. The armored division retained a four-troop squadron.
42. Field Manual 17-35, Armored Cavalry Platoon, Troop and Squadron (Washington, DC: 1960), p. 159.

43. Ibid., pp. 167-169.
44. GEN Donn A. Starry, Armoured Combat in Vietnam (Dorset, England: Blandford Press, 1981), pp. 227-229. The six squadrons were 1 Sqn 1 Cav, Americal Division; 2 Sqn 1 Cav, attached to 4th Infantry Division; 1 Sqn 4 Cav, 1st Infantry Division; 3 Sqn 4 Cav, 25th Infantry Division; 3 Sqn 5 Cav, 9th Infantry Division; and 1 Sqn 10 Cav, 4th Infantry Division. Numerous separate troops, air cavalry units, and one armored cavalry regiment (11th) also saw action.
45. A student paper by Major William B. Blake, "Missions and Techniques of Employment of Ground Armored Cavalry Units in Vietnam" (March 1973) provides an excellent summary of the types of missions performed by ground cavalry in Vietnam. See also GEN Donn A. Starry, Armoured Combat in Vietnam (Dorset, England: Blandford Press, 1981), Chapters III through V, for numerous examples of air and ground cavalry operations.
46. Starry, Armoured Combat in Vietnam, p. 56.
47. Ibid., pp. 55-57.
48. Ibid., pp. 54-72. This segment describes the deployment and first combat engagements by 1 Sqn 4 Cav, 1st Infantry Division.
49. Major William B. Blake, "Missions and Techniques of Employment of Ground Armored Cavalry Units in Vietnam" (March 1973), p. 2. See also Starry, Armoured Combat in Vietnam, pp. 84-90.
50. COL George S. Webb, "More Cavalry for the Infantry Division," Military Review (January 1969), p. 18.
51. Starry, Armoured Combat in Vietnam, p. 221.
52. Field Manual 17-95, Cavalry (Washington, DC: 1977), p. i.
53. The United States Army Armor School Combat and Training Developments Study, "Security and Reconnaissance Requirements for European Based Ground Forces (EUROCAV)," Volume I (1973), a study that examined possible cavalry employment in a European scenario in the 1976-1986 timeframe, even recommended two three-tank sections per platoon (See pp. E-2, E-4 to E-8).
54. Ibid., p. E-8. The author of this monograph, having commanded both a cavalry platoon and a cavalry troop prior to the removal of the infantry squad from the cavalry platoon, feels qualified to comment on the value of this squad in tactical operations. While, as the EUROCAV study

points out, one squad was hardly adequate, it was, nevertheless, a valuable asset. The squad provided local security for the tank section, freeing the scouts for more appropriate use as observation/listening posts. The squad could be used for dismounted patrolling, again freeing scouts to man observation/listening posts. During route and zone reconnaissance, the infantry squad, with mine detectors and platoon demolition kit, was the perfect element to physically recon and clear routes, freeing scouts to move to the front and flanks of the platoon. The squad was invaluable for clearing and securing defiles, bridges, small villages, and chokepoints prior to moving vehicles through. In short, the squad performed a variety of important dismounted missions that the platoon's scouts are now hard pressed to perform in its absence.

55. Field Manual 17-10, pp. 277-278.
56. "Operational and Organizational Concept. Division and Corps B6 Cavalry," U.S. Army Armor Center and Fort Knox (10 November 1980), p. 1-1.
57. Field Manual 17-100, Divisional Cavalry Squadron (Fort Knox, KY: undated working draft), p. 3-2.
58. Sources for the comparison are the 1978-1979 Armor Reference Data, Volume 1, pp. 56-57 and Field Circular 71-8, Army of Excellence Close Combat Heavy Brigade and Divisional Cavalry Squadron Organization (Preliminary Draft, October 1984), pp. 4-11 to 4-13.
59. Missions listed for the H-series squadron are as discussed in FM 17-95, Cavalry (1977). Missions for the AOE squadron are as listed in FC 71-8, Army of Excellence Close Combat Heavy Brigade and Divisional Cavalry Squadron Organization (Preliminary Draft, October 1984).
60. "Operational and Organizational Concept, Division and Corps Cavalry," p. 1-1.
61. MAJ Thomas A. Dials, "Economy of Force--the Cavalry Connection," Armor (July-August 1983), p. 45.
62. MAJ Robert P. Bush, "The Division Commander's Eyes and Ears," Armor (September-October 1983), p. 13.
63. One of the main purposes of the AOE study was "to determine where reductions or modifications to the approved Division B6 (October 1983 J-series TO&E) design could be implemented to provide manpower and resource savings while maintaining the division's capability to perform its combat missions according to AirLand Battle doctrine." (CACDA Final Report. "The Army of Excellence, Volume III: The Heavy Division," 1 October 1984, p. 1).

64. CPT Donald C. Snedeker, "Mobility: The Key to Cavalry," Armor (September-October 1974), p. 30.
65. Bush, p. 16.
66. SSG Peter L. Bunce, "The Reconnaissance Dilemma," Armor (March-April 1976), p. 19.
67. 2LT Geoffrey C. Davis, "The Three D's of Reconnaissance," Armor (March-April 1982), p. 24.
68. COL H. S. Stewart, "Mechanized Cavalry Has Come to Stay," The Cavalry Journal (November-December 1938), p. 487.
69. LTC Bruce Palmer, Jr., "New Battle Lessons on Reconnaissance," Armor (May-June 1985), p. 23.
70. Snedeker, p. 31. Unfortunately for "sneak and peek" advocates, the M3 CFV hardly fits this description. While it is fast and possesses excellent cross-country mobility, its powerful diesel engine and full-tracked suspension system are hardly "silent," and at 2.972 meters high it is taller than an M113 APC or an M1 tank. Nor, at 21.8 tons, can it be considered light and it can swim only after erecting a flotation barrier (See CPT Gerald Halbert, "The Bradley Versus the Opposition," Armor, May-June 1982, pp. 26-30).
71. LTC Allen D. Hulse, "Principles and Modern Methods of Reconnaissance," The Cavalry Journal (July-August 1946), p. 69.
72. General Board, USFET, Study #49, p. 9.
73. Christopher R. Gabel, "Evolution of U.S. Armor Mobility," Military Review (March 1984), p. 62.
74. CPT Reuben F. Trant, Jr. and CPT Dale Stithem, "From Paris to Belgium. 125th Reconnaissance Squadron in Pursuit of Routed Germans," The Cavalry Journal (March-April 1945), p. 16.
75. AOAC Research Report #17, p. 2.
76. Dials, p. 44.
77. Field Manual 100-5, 1944, p. 306.
78. Dials, p. 45.
79. General Board, USFET, Study #49, Appendix 7, p. 1.
80. AOAC Report #17, p. 141.

81. See FM 100-2-3, The Soviet Army, Troops, Organization and Equipment (Washington, DC: 1984), p. 4-67 for a description of the organization and equipment of the divisional reconnaissance battalion.
82. See FM 100-2-1, The Soviet Army, Operations and Tactics (Washington, DC: 1984), Chapter 7 for a discussion of the various organizations used for reconnaissance. Page 6-5 describes the use in the defense of the motorized rifle division's second echelon elements to man the security zone: "A security force of up to battalion size may be deployed in front of each first echelon regiment." See also Chris Donnelly, "Soviet Reconnaissance--II," Journal of the Royal United Services Institute for Defence Studies (March 1976), pp. 68-75; MG S. Patrikeyev, "Reconnaissance in Strength," Soviet Military Review (No 12, 1973), pp. 22-25; and COL A. Popov, "Reconnaissance in Strength," Soviet Military Review (No 3, 1979), pp. 39-41. (These last three articles show the emphasis the Soviets place on what our doctrine calls "reconnaissance in force" to obtain information by combat when necessary, using regular tank and motorized rifle forces.)
83. Field Circular 71-8, pp. 4-36 to 4-38, and Field Manual 100-2-3, pp. 4-2 and 4-22. Note that this is a new problem unique to the AOE squadron--its H-series predecessor also lacked dismounted strength, particularly following the removal of the infantry squad from the cavalry platoon following the EUROCAV Study.
84. Dials, p. 46.
85. COL Crosbie E. Saint, "Cavalry Today," Armor (July-August 1977), p. 61.
86. MG Donn A. Starry, "The Commander's Hatch: Modern Armor Battle III--Cavalry," Armor (March-April 1975), p. 7.
87. White, p. 51.
88. LTC William T. Bird, "Considerations for the Employment of Mechanized Cavalry," Military Review (January 1945), p. 75.
89. Ibid., p. 73.
90. CPT Stewart J. Seborer, "Brief for a Cavalry Combat Platoon," The Cavalry Journal (March-April 1946), p. 55.

## BIBLIOGRAPHY

### BOOKS

- Gillie, Mildred Hanson. Forging the Thunderbolt. Harrisburg, PA: The Military Service Publishing Company, 1947.
- Niehorster, Lee. World War II Organization and Equipment-- Book 1. German Army Panzer and Panzergrenadier Divisions 1943-1944. Brooklyn, NY: Enola Games, 1982.
- Scheibert, Horst. Panzergrenadiere, Krad-Schutzen und Panzer-Aufklarer 1935-1945. Hanau, FRG: undated.
- Starry, Donn A. Armoured Combat in Vietnam. Dorset, England: Blandford Press, 1981.
- Stubbs, Mary Lee and Stanley Russell Connor. Army Lineage Series: Armor-Cavalry, Part I. Washington, DC: Office of the Chief of Military History, U.S. Army, 1969.

### MANUALS

- Field Circular 71-8, Army of Excellence Close Combat Heavy Brigade and Divisional Armored Cavalry Squadron (Preliminary Draft). Fort Knox, KY: U.S. Army Armor School, October 1984.
- Field Circular 71-100, Armored and Mechanized Division and Brigade Operations. Fort Leavenworth, KS: U.S. Army Command and General Staff College, 1984.
- Field Manual 17-10, Armored Force Field Manual Tactics and Techniques. Washington, DC: U.S. Government Printing Office, 1942.
- Field Manual 17-22, Armored Force Field Manual Reconnaissance Battalion. Washington, DC: U.S. Government Printing Office, 1942.
- Field Manual 17-22, Reconnaissance Platoon and Company. Washington, DC: U.S. Government Printing Office, 1950.
- Field Manual 17-35, Armored Cavalry Platoon, Troop and Squadron. Washington, DC: U.S. Government Printing Office, 1960.
- Field Manual 17-36, Divisional Armored and Air Cavalry Units. Washington, DC: U.S. Government Printing Office, 1968.



Field Manual 17-36, Armored Cavalry Platoon, Troop and Divisional Cavalry Squadron. Washington, DC: U.S. Government Printing Office, 1973.

Field Manual 17-95, Cavalry. Washington, DC: HQ Department of the Army, 1977.

Field Manual 17-100, Divisional Cavalry Squadron. Fort Knox, KY: U.S. Army Armor School (undated draft).

Field Manual 100-2-1, The Soviet Army, Operations and Tactics. Washington, DC: HQ Department of the Army, 1984.

Field Manual 100-2-3, The Soviet Army, Troops, Organization and Equipment. Washington, DC: HQ Department of the Army, 1984.

Field Manual 100-5, Field Service Regulations: Operations. Washington, DC: U.S. Government Printing Office, 1941.

Field Manual 100-5, Field Service Regulations: Operations. Washington, DC: U.S. Government Printing Office, 1944.

Technical Manual E 30-451, Handbook on German Military Forces. Washington, DC: U.S. Government Printing Office, 1945.

#### ARTICLES AND PERIODICALS

"The Air-Cavalry Team in Reconnaissance." The Cavalry Journal. July-August 1946, pp. 76-78.

Andrews, MAJ Michael A. "A New Breed: Active Defense Cavalrymen." Armor. July-August 1979, pp. 20-22.

Barnaby, CPT Kenneth T., Jr. "Face-Lifting a Cavalry Squadron." Armored Cavalry Journal. July-August 1946, pp. 8-12.

Battreal, LTC Raymond R., Jr. "Cavalry Operations." Armor. September-October 1968, pp. 48-52.

Bird, LTC William T. "Considerations for the Employment of Mechanized Cavalry." Military Review. January 1945, pp. 73-76.

Brindle, LTC Harry C. "The 86th Cavalry Reconnaissance Squadron. Screening of the 6th Armored Division near Muhlhausen, April 5-12, 1945." Armored Cavalry Journal. March-April 1946, pp. 14-22.

Bunce, SSG Peter L. "Cavalry Platoon Organization." Letter to the Editor, Armor. July-August 1975, p.2.

- Bunce, SSG Peter L. "The Reconnaissance Dilemma." Armor. March-April 1976, pp. 18-20.
- Burke, LTC Paul L. "Employment of Cavalry Assault Guns." The Cavalry Journal. November-December 1944, pp. 8-11.
- Bush, MAJ Robert P. "The Division Commander's Eyes and Ears." Armor. September-October 1983, pp. 13-17.
- Candler, LTC Harry W. "91st Reconnaissance Squadron in Tunisia." The Cavalry Journal. March-April 1944, pp. 14-22.
- Crouch, COL William W. "Soviet Reconnaissance Operations." Armor. November-December 1981, pp. 28-29.
- Davis, 2LT Geoffrey C. "The Three D's of Reconnaissance." Armor. March-April 1982, pp. 24-25.
- Dials, MAJ Thomas A. "Economy-of-Force--the Cavalry Connection." Armor. July-August 1983, pp. 42-46.
- Disney, COL Paul A. "Armored Cavalry of the Present--and Future." Armored Cavalry Journal. January-February 1948, pp. 33-34.
- Donnelly, Chris. "Soviet Reconnaissance--II." Journal of the Royal United Services Institute for Defence Studies. March 1976, pp. 68-75.
- "The 87th Cavalry Reconnaissance Squadron. Attack Against Meinkenbracht, April 12, 1945." Armored Cavalry Journal. July-August 1946, pp. 6-7.
- "The 89th Cavalry Reconnaissance Squadron. Delaying Action by Troops A, B, C and E in the Befort, December 16-25, 1944." Armored Cavalry Journal. September-October 1946, pp. 20-21.
- Ficklen, CPT Jack H. "A Reconnaissance Squadron in Tunisia." The Cavalry Journal. July-August 1943, pp. 16-18.
- Gabel, Christopher R. "Evolution of US Armor Mobility." Military Review. March 1984, pp. 54-63.
- Gavin, MG James M. "Cavalry, and I Don't Mean Horses." Armor. May-June 1954, pp. 18-22.
- Gavin, MG James M. "The Future of Armor." Armored Cavalry Journal. November-December 1947, pp. 2-6.
- Gredasov, LTG F. "Reconnaissance in Modern Battle." Soviet Military Review. No. 6, 1984, pp. 14-16.

- Halbert, CPT Gerald A. "The Bradley Versus the Opposition." Armor. May-June 1982, pp. 26-30.
- Heavey, MAJ Thomas J. "The Horse-Mechanized Regiment." The Cavalry Journal. September-October 1940, pp. 424-428.
- Heiberg, LTC H. H. D. "Armored Reconnaissance." The Cavalry Journal. May-June 1942, pp. 66-70.
- Hoy, LTC Charles J. "Trends in Mechanized Cavalry." The Cavalry Journal. July-August 1945, pp. 57-58.
- Hulse, LTC Allen D. "Principles and Modern Methods of Reconnaissance." The Cavalry Journal. July-August 1946, pp. 66-69.
- Jackson, LTC Lawrence M. III. "Force Modernization--Doctrine, Organization, and Equipment." Military Review. December 1982, pp. 2-12.
- Jones, CPT Carleton P., Jr. "Mounted Attack, Mechanized." The Cavalry Journal. July-August 1945, pp. 31-33.
- King, LTC James J. and LTC Melvin A. Goers. "Modern Armored Cavalry Organization." Armored Cavalry Journal. July-August 1948, pp. 45-50.
- Lancaster, MAJ Michael S. "The Armor Force in the AirLand Battle." Armor. January-February 1982, pp. 26-32.
- Lindsay, CPT S. A. "Assault Guns as Attachments and in Battery." The Cavalry Journal. March-April 1945, pp. 17-19.
- "Mechanized Cavalry on Reconnaissance." The Cavalry Journal. July-August 1944, pp. 68-70.
- "Mechanized Cavalry Operations." Armored Cavalry Journal. July-August 1946, p. 13.
- Mineyev, MAJ A. "In a Recce Party." Soviet Military Review. No 5, 1983, pp. 26-28.
- Palmer, LTC Bruce, Jr. "New Battle Lessons on Reconnaissance." Armor. November-December 1985, pp. 22-23. (Reprinted from 1941 issue of The Cavalry Journal.)
- Patrikeyev, MG S. "Reconnaissance in Strength." Soviet Military Review. No 12, 1973, pp.22-25.

- Patton, MG George S. "Some Thoughts on Cavalry." Armor. May-June 1979, pp. 27-29.
- Popov, COL A. "Reconnaissance in Strength." Soviet Military Review. No 3, 1979, pp. 39-41.
- "Reconnaissance in Normandy." The Cavalry Journal. November-December 1944, pp. 12-15.
- Rizatdinov, LTG S. "Reconnaissance in Exercises." Infantry. July-August 1980, pp 25-27. (Abstracted from Soviet Press: Selected Translations, No 80-4, April 1980, AFPR 200-1.).
- Rosenberg, LTC Ralph G. and MAJ Michael S. Lancaster. "Command and Control for the Division 86 Squadron." Military Review. November 1981, pp. 49-56.
- Saint, COL Crosbie E. "Cavalry Today." Armor. July-August 1977, pp. 60-63.
- Scott, MG C. L. "Armored Reconnaissance." The Cavalry Journal. November-December 1942, pp. 20-22.
- Seborer, CPT Stewart J. "Brief for a Cavalry Combat Platoon." The Cavalry Journal. March-April 1946, p. 55.
- Snedeker, CPT Donald C. "Mobility: The Key to Cavalry." Armor. September-October 1974, pp. 26-31.
- Starry, MG Donn A. "The Commander's Hatch: Modern Armor Battle III--Cavalry." Armor. March-April 1975, pp. 5-8.
- Steward, MAJ Hal D. "Cavalry in World War II." The Cavalry Journal. May-June 1946, p. 27.
- Stewart, COL H. S. "Mechanized Cavalry Has Come to Stay." The Cavalry Journal. November-December 1938, pp. 483-490.
- Trant, CPT Reuben F., Jr., and CPT Dale Stithem. "From Paris to Belgium. 125th Reconnaissance Squadron in Pursuit of Routed Germans." The Cavalry Journal. March-April 1945, pp. 12-16.
- Veselov, COL L. "Company in a Recce Detachment." Soviet Military Review. No 8, 1978, pp. 14-15.
- Vigor, P. H. "Soviet Reconnaissance--Part I." Journal of the Royal United Services Institute for Defence Studies. December 1975, pp. 41-45.
- Voorhies, CPT Don W. "Help Wanted: A Cavalry Rifle Troop." The Cavalry Journal. September-October 1945, p. 70.

- Webb, COL George S., Jr. "More Cavalry for the Infantry Division." Military Review. January 1969, pp. 14-21.
- White, MAJ I. D. "The Armored Force Reconnaissance Battalion, Armored Division." The Cavalry Journal. May-June 1941, pp. 48-52.
- Whitehair, LTC Jay C. "Cavalry--Employment of Mechanized Reconnaissance Elements." Military Review. May 1943, pp. 24-28.
- Woodhall, CPT Jeffery W. "The 26th Cavalry in the Philippines." Armor. January-February 1983, pp. 8-16.

#### DOCUMENTS

- Argersinger, MAJ Steven J. "An Operational Concept for the Battlefield Defeat of the Soviets Based on an Analysis of the Soviet Decision Cycle," 1984, MMAS Thesis, Fort Leavenworth. CARL ref #ABD088367-4.
- Army Ground Force Board MTOUSA, Immediate Report #A299, 16 February 1945. "Report on 91st Reconnaissance Squadron, Mechanized." CARL ref #NB394.
- Army Ground Force Board MTOUSA, Immediate Report #A318, 28 February 1945. "Operations of 91st Reconnaissance Squadron, Mechanized, in Italy, 1 November 1943 to 20 February 1945." CARL ref #NB933.
- Army Ground Forces Board MTOUSA, Immediate Report #344, 19 March 1945. "88th Cavalry Reconnaissance Troop, Mechanized, in the Italian Theater." CARL ref #N9286.
- Army Ground Force Equipment Review Board, Part I. "Report of Board of Officers Convened to Study the Equipment of the Post-War Army," 20 June 1945. CARL ref #R10445.A.
- Army Ground Forces Study No. 8. "Reorganization of Ground Troops for Combat," 1946. CARL ref #N14792.
- Army Ground Forces Study No. 27. "The Armored Force Command and Center," 1946. CARL ref #N14787.
- Baker, LTC Ronald L. "What in the Hell Did They Do to the Cav?" US Army War College Individual Essay, Carlisle Barracks, PA, 28 April 1983. DTIC ref #ADA 130086.
- Blake, MAJ William B. "Missions and Techniques of Employment of Ground Cavalry Units in Vietnam." CGSC Student Paper, March 1973. CARL ref #NB224.792.

CACDA Final Report. "The Army of Excellence, Volume III: The Heavy Division," 1 October 1984.

CACDA Final Report. "Division 86 Final Report," October 1981 with June 1983 Addendum.

Cavalry Reconnaissance Numbers 1, 2, 5, and 7. Factual narratives prepared by the Cavalry School. CARL ref #N17689.2C, D, E, and F.

"Conference Conclusions to Agenda for the Armored Conference," 22 May 1946. CARL ref #N13545.

"Critical Analysis of the History of Armor in World War II," AOAC Research Report #17, April 1953. CARL ref #N2146.5.

Disney, COL Paul A. "Operations of the 82d Armored Reconnaissance Battalion in the Sicilian Campaign, July 10-22, 1943." CGSC School of Combined Arms Regular Course 1946-47.

Headquarters IX Corps Combat Notes #4 and 7, 8 August and 20 October 1951. CARL ref #N17056.12.

Headquarters Twelfth Army Group Immediate Report #24, "Conference with Major General Leroy H. Watson, Commanding 3d Armored Division." 7 October 1944. CARL ref #N3351.

"The Heavy Reconnaissance Vehicle for the Reconnaissance Platoon," AOAC Research Report, Committee #5, April 1953. CARL ref #N2146.87.

"The Need for a Lightly Armored Vehicle in U.S. Reconnaissance Units," AOAC Research Report, Committee #38, May 1952. CARL ref #N2146.102.

"Operational and Organizational Concept. Division and Corps 86 Cavalry." U.S. Army Armor Center and Fort Knox, 10 November 1980. DTIC file #ADB 053974.

"Operation of Cavalry Reconnaissance Squadrons Integral to the Armored Division," AOAC Research Report #17, May 1950. CARL ref #N2146.53.

"Organization, Equipment and Tactical Employment of the Armored Division," The General Board, United States Forces, European Theater, Study No. 48, 7 November 1949. CARL ref #12875-2.

"Reference Data for Armored Units," the Armor School, March 1956, September 1960, June 1964, and 1978-79. CARL ref #N18000.55 and N18000.55A.

"Report of the Army Field Forces Advisory Panel on Armor, Volumes I and II," 18 February 1949. CARL ref #N16458A&B.

"Report of the War Department Equipment Board," 19 January 1946. CARL ref #N12960.

Romjue, John L. TRADOC Monograph Series, "A History of Army 86, Volume I. Division 86: The Development of the Heavy Division," September 1978-October 1979.

Romjue, John L. TRADOC Monograph Series, "A History of Army 86, Volume II. The Development of the Light Division, the Corps, and Echelons Above Corps," November 1979-December 1980.

Rozelle, MAJ Joseph H. "The Armored and Mechanized Division Armored Cavalry Squadron," 1977, MMAS Thesis, Fort Leavenworth. CARL ref #ADA 042867.

"A Standard Reconnaissance Battalion," AOAC Research Report #6, April 1953. CARL ref #N2146.89.

"Tactics, Employment, Technique, Organization, and Equipment of Mechanized Cavalry Units," The General Board, United States Forces, European Theater, Study No. 49, 4 February 1947. CARL ref #N12875.49-2.

United States Army Armor School Combat and Training Developments Study, "Security and Reconnaissance Requirements for European Based Ground Forces (EUROCAV) Volume I," 1973. CARL ref #18000.70-A.

United States Army Combat Development Command Study, "Armor, Air and Ground Operations 1965-70," Coordination Draft, April 1965. CARL ref #18968.35.

END

DTIC

6-86