

MICROCOPY

CHART



AFIT/GSO/ENS/85D-11

AD-A167 122

DTIC
ELECTE
MAY 13 1986
S D
D

A KERNEL DECISION SUPPORT SYSTEM FOR
CANADIAN MILITARY SATELLITE COMMUNICATIONS
SYSTEM PLANNING

THESIS

J. Robert Leitch
Major, Canadian Forces

AFIT/GSO/ENS/85D-11

Approved for public release; distribution unlimited

86 5 13 005

UNCLASSIFIED

SECURITY CLASSIFICATION OF THIS PAGE

REPORT DOCUMENTATION PAGE

1a. REPORT SECURITY CLASSIFICATION UNCLASSIFIED			1b. RESTRICTIVE MARKINGS NONE			
2a. SECURITY CLASSIFICATION AUTHORITY			3. DISTRIBUTION/AVAILABILITY OF REPORT Approved for public release; distribution unlimited.			
2b. DECLASSIFICATION/DOWNGRADING SCHEDULE						
4. PERFORMING ORGANIZATION REPORT NUMBER(S) AFIT/GSO/ENS/85D-11			5. MONITORING ORGANIZATION REPORT NUMBER(S)			
6a. NAME OF PERFORMING ORGANIZATION School of Engineering Air Force Institute of Technology AFIT/ENS		6b. OFFICE SYMBOL <i>(If applicable)</i>	7a. NAME OF MONITORING ORGANIZATION			
6c. ADDRESS (City, State and ZIP Code) Wright-Patterson AFB, Ohio 45433			7b. ADDRESS (City, State and ZIP Code)			
8a. NAME OF FUNDING/SPONSORING ORGANIZATION		8b. OFFICE SYMBOL <i>(If applicable)</i>	9. PROCUREMENT INSTRUMENT IDENTIFICATION NUMBER			
8c. ADDRESS (City, State and ZIP Code)			10. SOURCE OF FUNDING NOS.			
			PROGRAM ELEMENT NO.	PROJECT NO.	TASK NO.	WORK UNIT NO.
11. TITLE (Include Security Classification) See Box 19						
12. PERSONAL AUTHOR(S) James Robert Leitch, Major Canadian Forces						
13a. TYPE OF REPORT MS Thesis		13b. TIME COVERED FROM _____ TO _____		14. DATE OF REPORT (Yr., Mo., Day) 1965 December		15. PAGE COUNT 139
16. SUPPLEMENTARY NOTATION						
17. COSATI CODES			18. SUBJECT TERMS (Continue on reverse if necessary and identify by block number)			
FIELD	GROUP	SUB GR	DECISION MAKING; OPERATIONS RESEARCH; DECISION SUPPORT; MILSATCOM PLANNING; LINK ANALYSIS			
12	02					
22	02					
19. ABSTRACT (Continue on reverse if necessary and identify by block number) Title: A KERNEL DECISION SUPPORT SYSTEM FOR CANADIAN MILITARY SATELLITE COMMUNICATIONS SYSTEM PLANNING Advisor: Maj Skip Valusek Reader: Capt Glenn Prescott						
<i>Approved for public release 15W APR 1967</i> John E. Wolaver 13Feb66 Dean for Research and Professional Development Air Force Institute of Technology (AFIT) Wright-Patterson AFB OH 45433						
20. DISTRIBUTION AVAILABILITY OF ABSTRACT UNCLASSIFIED UNLIMITED <input type="checkbox"/> SAME AS RPT <input checked="" type="checkbox"/> DTIC USERS <input type="checkbox"/>			21. ABSTRACT SECURITY CLASSIFICATION UNCLASSIFIED			
22a. NAME OF RESPONSIBLE INDIVIDUAL Major John R. Valusek, PhD			22b. TELEPHONE NUMBER <i>(Include Area Code)</i> (513) 255-2549		22c. OFFICE SYMBOL AFIT/ENS	

ABSTRACT: The kernel requirements for a DSS to plan technically feasible SATCOM systems is developed. The literature review focuses on understanding the decision process and a search for a suitable analytic tool for SATCOM system design. A model of the decision process is developed. The model is found to be a semi-structured task at the management control level. The process involves independent and interdependent decisions at all levels of management. The decision process contains elements of the rational, satisficing, organizational procedures, political and individual differences perspectives of decision making. Link analysis is developed as the analytic tool to support the decision process. The initial equation is developed and the effects of multiple users and multiple access are added. Link analysis provides a straight forward method of determining technical feasibility. A set of parameters for link analysis and the attendant equations are developed. The representations, operations, memory aids, and control mechanisms necessary to implement the kernel DSS are determined. Two linkages for future modules were identified: the Analytic Hierarchy Process as a module to determine the SATCOM user's evaluation criteria and a cost module. The research concludes that a DSS is well suited to the SATCOM planning process.

AFIT/GSO/ENS/85D-11

A KERNEL DECISION SUPPORT SYSTEM FOR
CANADIAN MILITARY SATELLITE COMMUNICATIONS
SYSTEM PLANNING

THESIS

Presented to the Faculty of the School of Engineering
of the Air Force Institute of Technology
In Partial Fulfillment of the
Requirements for the Degree of
Master of Science in Space Operations

J. Robert Leitch
Major, Canadian Forces

December 1985

Approved for public release; distribution unlimited

Preface

The purpose of this research was to identify the kernel element of a decision support system to assist in MILSATCOM planning for the Canadian Forces. My initial research indicated that operations research techniques had not been extensively applied to SATCOM planning. A DSS appeared to be a means of integrating these disciplines.

The report is limited in scope to identifying the requirements for a DSS to determine technical feasibility of a planned SATCOM system. The research identifies an analytic tool as well as the initial capabilities required for a 'prototype' DSS. "Hooks" for additional management science/operations research capabilities are also identified.

I would like to acknowledge the assistance I received from Major Skip Valusek and Captain Glenn Prescott of the Air Force Institute of Technology. Their support and guidance were vital to the completion of this research. Particular thanks to Skip for his patience and interest. I am grateful to LCol Glen Ewen of National Defence Headquarters (DCESR) for his sponsorship and the assistance he provided.

The crucial support I received was from my family: Janette, Jamie, and Cameron. Without their patience and understanding I could not have completed this effort.

Accession For	
NTIS	CRA&I <input checked="" type="checkbox"/>
DTIC	TAB <input type="checkbox"/>
Unannounced <input type="checkbox"/>	
Justification	
By	
Distribution /	
Availability Codes	
Dist	Avail and/or Special
A-1	



Table of Contents

	Page
Preface	ii
List of Figures	v
List of Tables	vi
Abstract	vii
I. Introduction	1-1
Background	1-1
Statement of the Problem	1-5
Research Question	1-6
Objectives of the Research	1-7
Scope	1-8
Methodology	1-9
Sequence of Presentation	1-9
II. Background Theory	2-1
Introduction	2-1
The Decision Process	2-2
Iterative Design	2-12
Systems Analysis	2-14
SATCOM Technical Analysis	2-17
MS/OR Techniques	2-18
III. The Decision Process	3-1
Background	3-1
The Decision Process Model	3-3
Analysis of the Decision Process	3-8
IV. SATCOM Link Analysis	4-1
Introduction	4-1
Link Budget	4-1
Multiple Signals	4-10
Multiple Access	4-12
Frequency Division Multiple Access	4-14
Time Division Multiple Access	4-17
Code Division Multiple Access	4-20
Link Analysis Parameters	4-21
V. ROMC Analysis	5-1
Introduction	5-1

	Page
Representations	5-2
Operations	5-6
Memory Aids	5-10
Control Mechanisms	5-12
"Hook" Book	5-13
 VI. Conclusions and Recommendations	 6-1
Summary	6-1
Conclusions	6-4
Recommendations	6-5
 Appendix A: Proposed Tables Representations Link Budget	 A-1
General Parameters	A-1
Uplink Parameters	A-2
Downlink Parameters	A-3
End-to-end Parameters	A-4
 Appendix B: Proposed Equation Representation	 B-1
Elevation Angle	B-1
Free Space Loss	B-1
Gain	B-1
Noise Temperature	B-2
Required Bit Power-to-Noise Density	B-2
 Appendix C: Sample Link Calculations and ROMC Discussion	 C-1
 Bibliography	 BIB-1
 Vita	 V-1

List of Figures

Figure	Page
1-1. The DPMS Process	1-3
1-2. Block Diagram of a Typical Digital Communications System.	1-10
2-1. Steps in the Decision Making Process	2-7
2-2. The Interdisciplinary Framework of Decision Making.	2-8
2-3. System Design and Testing Flow Diagram	2-20
3-1. The DPMS Process	3-2
3-2. System Design and Testing Flow Diagram	3-4
3-3. The SATCOM Decision Process.	3-6
4-1. Satellite Link Block Diagram	4-2
4-2. Typical Noise and Attenuation Sources.	4-4
4-3. TDMA Frame Format.	4-18
5-1. Sample Block Diagram of Satellite Transponder.	5-3
5-2. Sample Link Budget Chart	5-4
5-3. Sample Graph Representation of Operating Curves.	5-5
6-1. The SATCOM Decision Process.	6-2

List of Tables

Table	Page
2-1. Sample Customer-Acceptance Parameters.	2-22
5-1. Sample Table of Link Power Budget.	5-2

Abstract

The kernel requirements for a DSS to plan technically feasible SATCOM systems is developed. The literature review focuses on understanding the decision process and a search for a suitable analytic tool for SATCOM system design. A model of the decision process is developed. The model is found to be a semi-structured task at the management control level. The process involves independent and interdependent decisions at all levels of management. The decision process contains elements of the rational, satisficing, organizational procedures, political and individual differences perspectives of decision making. Link analysis is developed as the analytic tool to support the decision process. The initial equation is developed and the effects of multiple users and multiple access are added. Link analysis provides a straight forward method of determining technical feasibility. A set of parameters for link analysis and the attendant equations are developed. The representations, operations, memory aids, and control mechanisms necessary to implement the kernel DSS are determined. Two linkages for future modules were identified: the Analytic Hierarchy Process as a module to determine the SATCOM user's evaluation criteria and a cost module. The research concludes that a DSS is well suited to the SATCOM planning process.

A KERNEL DECISION SUPPORT SYSTEM FOR
CANADIAN MILITARY SATELLITE COMMUNICATIONS
SYSTEM PLANNING

I. Introduction

Background

The Canadian Forces have been indirectly involved in space through its Allied defence agreements. Recently, a more active role has been undertaken. A Special Advisor on Space Systems was created to specifically identify headquarter level components whose mandate would include an advocacy for space systems. One of these components was the Directorate of Communications and Electronics Specifications and Requirements (DCESR). This organization's responsibility is to identify requirements for military satellite communication (MILSATCOM) systems and provide suitable systems to the operational elements of the Canadian Forces.

DCESR is following a three phase program to implement satellite communications within the Canadian Forces. During the first phase SATCOM requirements will be met using completely commercial systems and hardware. Satellite ground terminals constructed to military specifications will be acquired in the second phase. These will use space and control segments which are leased or provided under Allied agreements. The third phase will see the development and implementation of a com-

plete Canadian MILSATCOM system.

There are a number of traits characterizing the environment in which MILSATCOM planning takes place. The first of these is the evolution of the user's requirements as he combines the need to replace old systems with the need to meet future tasks. The length of the planning and development cycle means that technological advances can lead to significant performance improvements. Both of these facts require that the planning process be flexible. Similarly the evolving national and defence space policies will impact on tactical planning. This evolution of policy will combine with the diversity of the MILSATCOM systems to make each requirement unique. The decision maker must select the appropriate system in a complex environment, making several trade-offs and evaluating against many criteria.

All of these activities take place within the Defence Services Program. The Defence Services Program (DSP) is a detailed plan of the costed activities and resource allocations of the Department of National Defence (DND). Although the DSP covers a fifteen year period, financial commitment is not made until the current year, following Parliamentary approval. The Defence Program Management System (DPMS) provides the means by which activities in the DSP are added, deleted, or modified.

The DPMS is the implementation of the government-wide Programming, Planning, Budgeting System (PPBS) within the DND. DPMS provides a framework for rational decision-making and decision-implementing. The DPMS process is shown in Figure 1-1. Shown sequentially for convenience, it is a repetitive process with continual feedback and interaction between all phases.

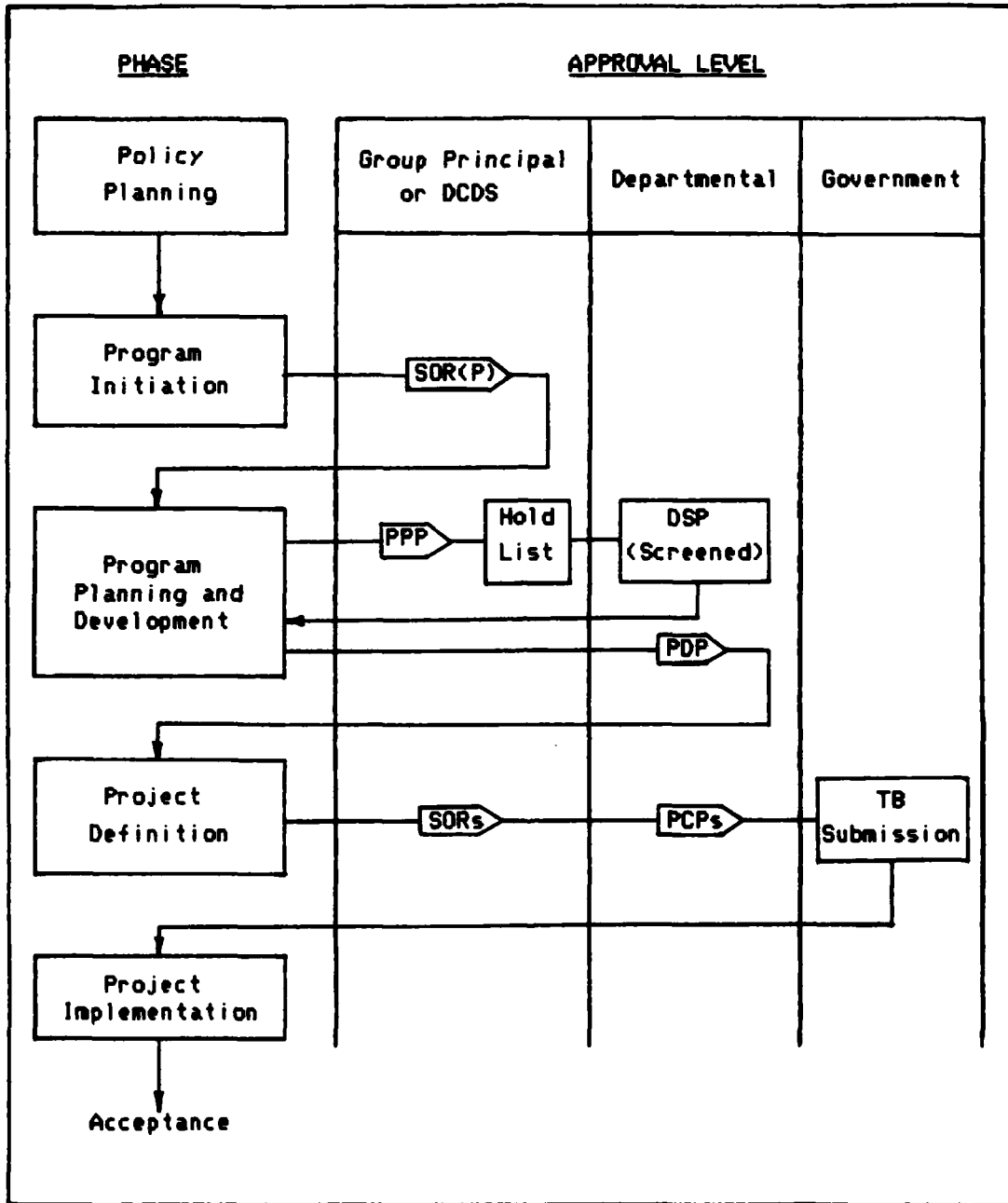

Figure 1-1. The DPMS Process (C Prog 500, 1981: Ch2, 2)

Policy Planning determines departmental goals and the capabilities required to meet them. A change to the DSP is initiated during the Program Initiation phase via a document called the Program Planning Proposal (PPP). A Program Development Proposal (PDP) is the document which seeks departmental approval-in-principle for future resource allocations at the end of the Program Planning and Development phase. During the Project Definition phase the Program Change Proposal (PCP) is the key document. This document obtains departmental approval, and, via Treasury Board (TB) submissions, Parliamentary approval. These approvals result in Project Implementation (C Prog 500, 1981: Ch2, 1-3).

The evolution of a MILSATCOM project through this procedure requires many decisions and the attendant support. Ralph H. Sprague characterizes a decision support system (DSS) as "an interactive computer based system, which helps decision makers utilize data and models to solve unstructured problems" (Sprague, 1980b: 8). Thus DSS represent a synthesis of electronic data processing/management information systems and management sciences/operations research. A DSS should assist a decision maker throughout the entire decision process.

A DSS's characteristics have evolved from the work of Alter, Keen, and others. These characteristics include:

- DSS focus on the less structured, under-specified problems usually faced by upper management levels;
- DSS attempt to combine analytic models with data management techniques;
- DSS stress easy interactive operation by noncomputer people; and
- DSS emphasize flexible adaptation to changes (Sprague,

1980a: 2).

Management sciences/operations research provide techniques that can be used to select courses of action. These techniques are mathematical in nature and are usually very structured. They direct the manager to the 'best' solution and provide an idea of the sensitivity of the solution to changes in the conditions of the problem. The models are of two broad natures. The first seeks to optimize a single objective function. Linear and dynamic programming are examples of this area. The second area is that of multi-criteria decision making. In this case, the decision maker has more than one objective or criterion which he is using to select the best alternative. Techniques include multi-attribute utility theory, compromise programming, and the analytic hierarchy process.

Statement of the Problem

Cost and technical feasibility are the two critical aspects of the MILSATCOM design effort. A MILSATCOM requirements planner provides the vital interface between the ultimate user and the design engineer. This interface must generate alternative systems which can meet the user's requirements in a cost effective, technically feasible manner. The alternatives should provide an indication of each system's advantages/disadvantages in nontechnical terms. At the same time the technical dimensions should reflect current technology and be expressible in engineering terms for the designer. Cost plays an important part in the selection of the final MILSATCOM system. There is a requirement for a decision support methodology that will provide an analytic method to generate

technically feasible MILSATCOM system alternatives. These alternatives would then be subject to cost analysis and the 'best' system selected. My study investigates the design criteria for a kernel DSS to support the formulation of technically feasible alternatives. By kernel, I mean a small key element of the decision process which can be supported by a DSS. The DSS kernel can later evolve as costing and other models are added until the entire decision is supported.

Research Question

Can a decision support methodology be developed to provide an efficient means of making MILSATCOM planning decisions with regard to technical feasibility? There are several key considerations involved in answering this question. What elements are required in the model base? Can operations research methods be used to optimize MILSATCOM system specifications during the design process? What are the database structure and user interface requirements necessary to implement this methodology in a DSS? What is the kernel of the decision support system which must be initially developed? What is the link between the user's requirements and design parameters (for example, between reliability and bit error rate)? What linkages must be identified in this study to allow cost considerations to be incorporated during the evolution of the DSS?

Objectives of the Research

The objective of this research effort is to develop a decision support methodology which will help MILSATCOM planners develop system specifications and determine the best tradeoffs to make in the system development process. The methodology identifies the key issue in the technical planning area and provides a structure for the DSS as well as linkages for future developments. The result is a statement of requirements for the initial implementation.

The following subobjectives were necessary to accomplish this research:

- Work with DCESR-3 to focus application and identify DSS system requirements.

- Develop the relations between system performance and design parameters (bandwidth, modulation, signal to noise ratio, etc.).

- Identify models suitable to the MILSATCOM planning problem.

- Identify database requirements to allow the models to work.

- Identify the kernel issue and formulate a methodology to implement it in a DSS.

The most significant challenge in this research was in structuring the model and developing an architecture within which the model will operate. This included developing the interface so that the user does not need a detailed technical understanding. Rather, the interface should allow the structure and architecture to be invisible to the user.

Scope

This research was limited to unclassified material. Unique Canadian information for the database was limited owing to the recent formation of the planning office and to the evolving nature of Canadian Space policy. To deal with this, concepts and trends were used. Data from commercial sources and open literature was used to fill deficiencies.

The methodology is intended to support planning for input to the Canadian Defence Program Management System. This covers the work done at National Defence Headquarters from Project Initiation to the end of the Project Definition Phase. It is assumed that the planning begins with a valid statement of requirements from the user. The problem is limited to the proposal of technically feasible alternatives to meet the user's needs. Factors such as cost, logistics, training, socio-economic tradeoffs, etc. are outside the scope of this initial research, but are important considerations for the evolution of the system. Where applicable, linkages necessary for future model addition are identified.

The intent was to propose a starting point for the initial development of a DSS. Many simplifying assumptions were made. It should be stressed that decision support system development is iterative. A prototype developed as a result of this research would not represent the final system, but would be a vehicle for validation and for further development and expansion. Later work would relax the limits of this research and extend the system.

Methodology

The first step in this research was to study the decision process involved in the design of MILSATCOM systems. It was studied with regard to structure, the factors acting in the process and key elements requiring decision support.

The second step was to develop an analytical tool to perform the technical feasibility analysis. I used the communications system model shown in Figure 1-2. This is typical of the many subsystems and design tradeoffs faced in planning a MILSATCOM system. The research developed a method to analyze the effects of the components and the transmission channel. This involved simplifying and combining blocks to develop workable dimensions. Probability of bit error was used as a measure of performance. This design tool allows certain design parameters to be varied in order to create alternate systems.

The last step was to identify the specifications for the kernel of the DSS. In addition, linkages to other models to be developed in the future were identified. Throughout the work outlined above there was a conscious effort to make the models user friendly and capable of being implemented interactively on a microcomputer. Similarly, data requirements and a database structure were developed.

Sequence of Presentation

Chapter Two of this thesis is a review of current literature. Areas which are investigated include the decision process, iterative design of DSS, SATCOM design techniques, and DSS systems analysis.

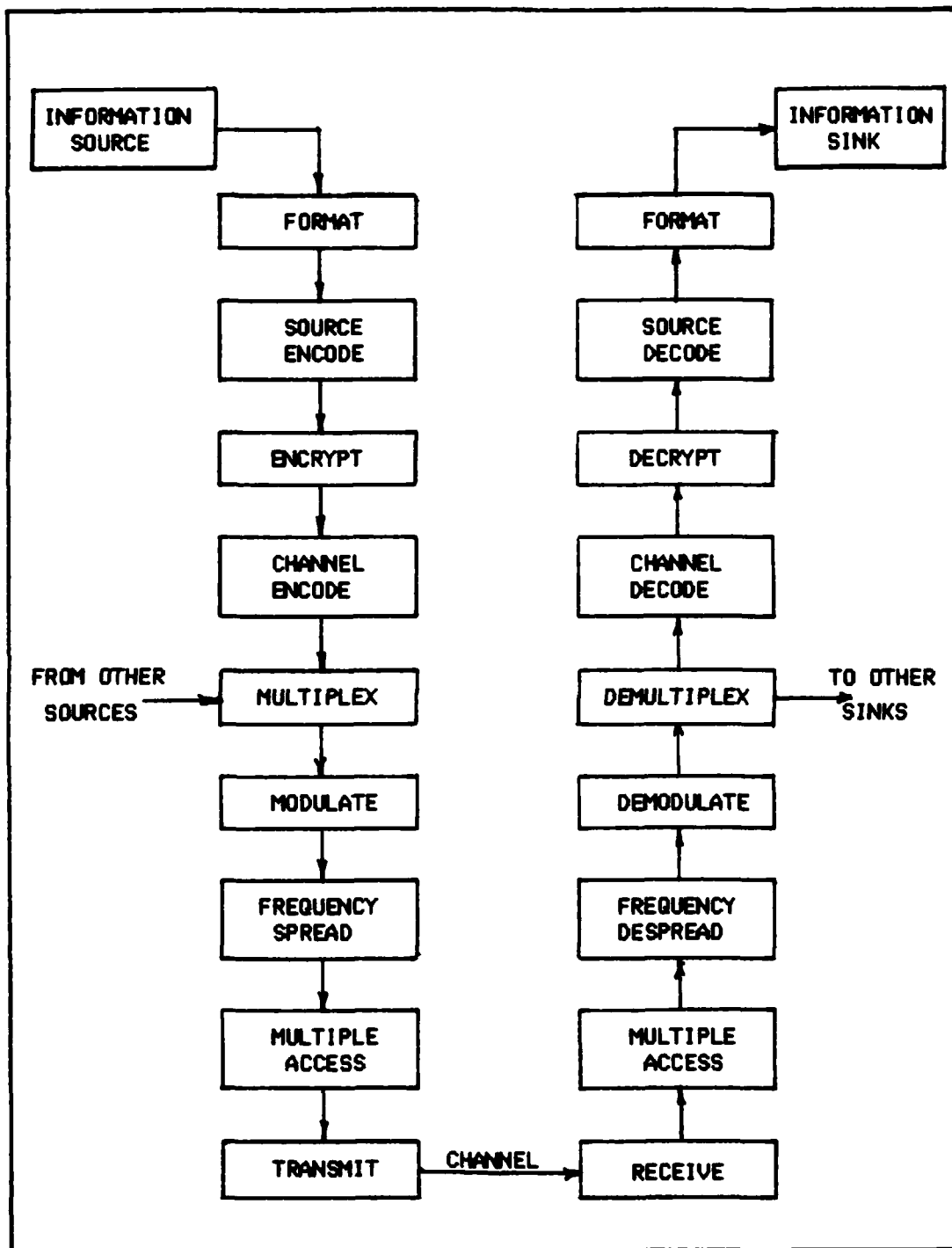

Figure 1-2. Block Diagram of a Typical Digital Communications System (Sklar, 1983: 5)

In Chapter Three the specific decision process will be presented. Within the context of the Defence Program Management System, the trade-offs in developing technically feasible alternatives to meet the user's requirements will be analyzed.

Chapter Four presents an analytic method to evaluate the technical trade-offs required to develop a feasible alternative.

Chapter Five is a systems analysis of the DSS requirements necessary to build the "kernel" system.

Chapter Six contains conclusions and recommendations for future research.

II. Background Theory

Introduction

This chapter is an overview of the literature pertaining to my research. Initially, decision making is examined in light of it's relevance to DSS and their design. As an aspect of the theory is developed, it's applicability to the design of technically feasible SATCOM systems is briefly discussed. The following sections deal with the evolutionary development of DSS and determining DSS requirements. A cornerstone of DSS is the iterative nature of their development. This phenomena is discussed in the third section. The requirement for active user participation in DSS design has also led to new methods of systems analysis. These methods are discussed in the fourth section.

The last two sections of the chapter deal with the design of SATCOM systems. A brief review of methods to determine the performance of SATCOM systems occurs first. The final section covers management science/operations research methods applicable to SATCOM design. One group of methods deals with techniques involving the design process. The other group pertains to the optimization of SATCOM performance.

The Decision Process

Decision making is a dynamic process: a complex search for information, full of detours. Enriched by feedback from casting about in all directions gathering and discarding information, fueled by fluctuating uncertainty, indistinct and conflicting concepts -- some sharp, some hazy; the process is an organic unity of both predecision and postdecision phases overlapping within the region of partial decisionmaking. Man is a reluctant decision maker, not a swift calculating machine (Zeleny, 1982: 86).

The study of the decision process is an outgrowth of many disciplines, including psychology, sociology, economics, and management science. This section reviews literature relating to the decision process. Following a definition of the decision process, five objectives of a DSS are presented. These objectives serve as a framework for developing the aspects of the decision process important to a DSS which will support the design and development of SATCOM systems. These aspects are:

- decision structure,
- level of decision-making,
- independent/interdependent decisions,
- decision-making phases, and
- the variety of decision-making processes.

The section ends with a summary of the five schools of thought concerning decision making.

Thierauf defines the decision-making process as a

series of steps that start with the analysis of the information and ultimately culminate in a resolution -- a selection from the several available alternatives and verification of this selected alternative (now and at some time in the future) to solve the problem under study (Thierauf, 1982: 87).

Sprague and Carlson list objectives for a specific DSS from the user's point of view:

1. A DSS should provide support for decision making, but with emphasis on semistructured and unstructured decisions...
2. A DSS should provide decision-making support for users at all levels, assisting in integration between the levels whenever appropriate...
3. A DSS should support decisions that are interdependent as well as those that are independent...
4. A DSS should support all phases of the decision-making process...
5. A DSS should support a variety of decision-making processes but not be dependent on any one (Sprague and Carlson, 1982: 26-27).

The first objective advances the concept of structure of the decision. The design of a SATCOM system is structured by the engineering principles upon which communication systems are based. The parameters to be included are known. However, the trade-offs between parameters are interrelated and complex. There is rarely a single solution to a design problem.

Simon outlined two types of tasks in which decisions are made: programmed and nonprogrammed. Programmed decisions are repetitive and routine in nature, capable of being handled by an established procedure. Nonprogrammed decisions are unusual, unique, and complex in nature. Nonprogrammed decisions have "elusive or complex" structure and are often of greater importance (Simon, 1960: 5-6). Keen and Scott-Morton use the terms structured and unstructured for programmed and nonprogrammed decisions, respectively. They also introduce semistructured tasks, those which have some structured subtasks. DSS focus on these semi-structured decisions, applying computer support to the structured components of the decision process and leaving the unstructured portions to the decisionmaker (Keen and Scott-Morton, 1978: 11-12).

Certainly the structure of the SATCOM design process is conducive

to a DSS. The computer can manipulate formulae and perform calculations, while the designer selects trade-offs and makes assumptions. The entire design process takes place within the structure of the Defence Program Management System.

The second objective pertains to the level within the organization at which decisions are made. A DSS to support SATCOM design will be used mostly in the areas of acquisition and resource allocation. There will also be a requirement to support the development of the Department's long range SATCOM plans. Similarly, the evolving role of SATCOM in the Canadian Forces will necessitate the formulation of policy and procedures.

Anthony describes three levels of managerial activities. These levels are strategic planning, management control, and operational control. Strategic planning is the

process of deciding on objectives of the organization, on changes in these objectives, on the resources used to attain these objectives, and on the politics that are to govern acquisition, use, and disposition of resources (Anthony, 1965: 24).

Strategic planning is normally conducted by top management. Top management requires innovative and creative approaches to deal with the unstructured tasks they face (Keen and Scott-Morton, 1978: 82). There is research which indicates that there is a basic structure underlying these unstructured strategic decisions (Mintzberg et al., 1976).

The second level, management control, is defined as the "process by which managers assure that resources are obtained and used effectively and efficiently in the accomplishment of the organization's objectives (Anthony, 1965: 27)". Operational control is the "process of assuring that specific tasks are carried out effectively and efficiently (An-

thony, 1965: 69)". These levels are the realms of middle and lower management, respectively. Some authors include a fourth level of activity for lower management, operational performance. This level relates to activities and decisions that are made in the conduct of day-to-day operations (Thierauf, 1982: 89; and Sprague and Carlson, 1982: 95). The levels of activity and management are not distinct, but rather form a continuum. SATCOM design operates in the upper portion of this continuum (strategic planning and management control).

As with any Headquarters, DCESR works closely with other Directorates in staffing requirements and acquiring systems. Initially an individual will work the problem, with inputs from other sources. As the program develops, the numbers of people involved will increase and decisions will become interdependent. In addition, the effects of a group of decision-makers will begin to take place.

The third objective deals with the number of people involved in the decision and the order in which they are involved in the process. In regards to the number of decision makers involved in the process, three decision types are attributed to Hackathorn and Keen

Independent: A decision maker has full responsibility and authority to make a complete implementable decision.

Sequential interdependent: A decision maker makes part of a decision, which is then passed on to someone else.

Pooled interdependent: The decision must result from negotiation and interaction among several decision makers (Sprague and Carlson, 1982: 26).

Some characteristics of group behavior affect the decision process. The first is called "groupthink" by Janis and Mann (Taylor, 1984: 174). Groupthink refers to the tendency of a group to overlook minority and outside opinions. "The result of groupthink is poor quality decision

making, characterized by a tendency to avoid controversial issues and failure to challenge weak arguments (Taylor, 1984: 175)". A DSS may make it easier to overcome the negative aspect of groupthink by opening communication channels and allowing consideration of these minority views (Koble, 1985: 18-19).

Two other characteristics of group behavior are risky shift and decision quality. Risky shift relates to the willingness of a group to make decisions that are more risky than an individual. Group decisions tend to be qualitatively better than an individual's, however more time is needed to reach a group decision (Radford, 1975: 201-202).

The sequence of steps in which a decision is made is addressed by the fourth objective. Herbert Simon has developed a popular model for the decision making process. The process consists of three steps: intelligence, design, and choice. Intelligence refers to searching the environment for conditions requiring decisions. Data is collected and analyzed, with the aim of problem identification. A decision maker then formulates and evaluates feasible courses of action during the design portion of the process. Lastly, a manager makes a choice and implements the selected course of action (Simon, 1960: 2-4). In many cases the implementation is considered as a separate step. Thierauf adds a final step, control. This step monitors the results and makes any adjustments, thus closing the loop to the intelligence phase. This is illustrated in Figure 2-1.

The main focus of the initial DSS will be on the intelligence and design phases. The intent is to generate one or more technically feasible alternatives. Later developments will see the development of a

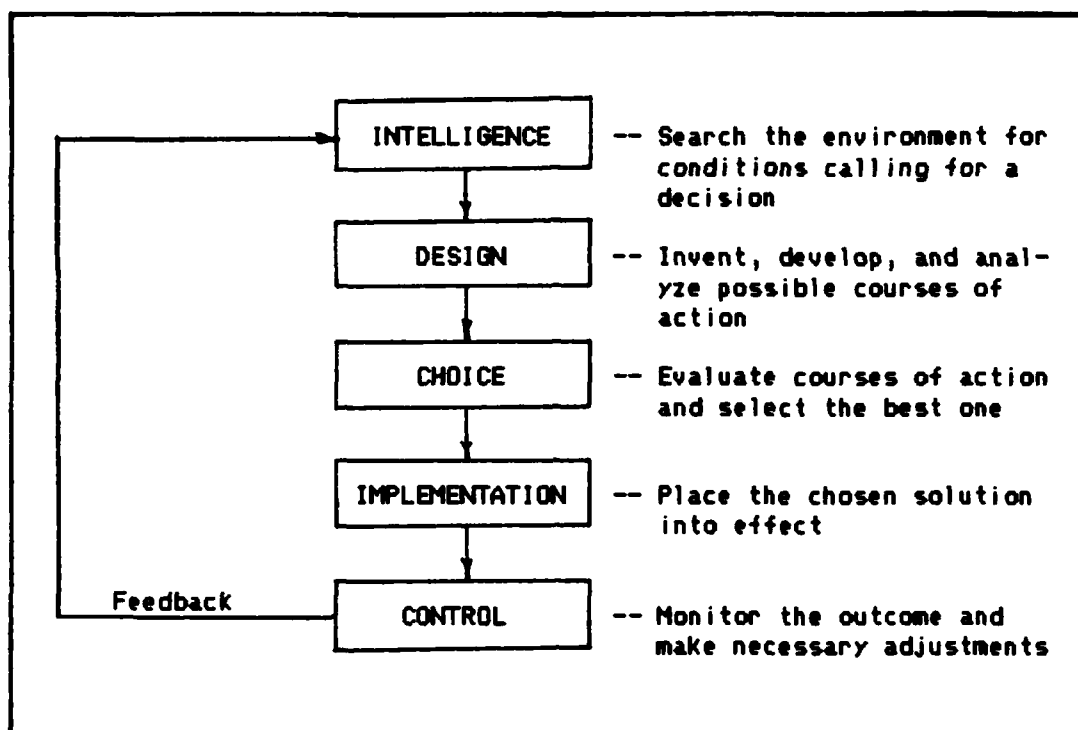

Figure 2-1. Steps in the Decision Making Process
(Thierauf, 1982: 105)

choice mechanism as well as a process to track implementation. In creating technically feasible alternatives, the evaluation of trade-offs will involve all of the phases in Figure 2-1.

The decision making process is multi-faceted. The fifth objective deals with a DSS's ability to deal with the many models of the decision process which have been developed. Decision making has been studied by many disciplines, each contributing to an understanding of the process. An idea of the interdisciplinary framework involved in the decision making process is provided in Figure 2-2. In order to deal with these contributions, the literature on decision making can be viewed from five perspectives. The five views which Keen and Scott-Morton outline are:

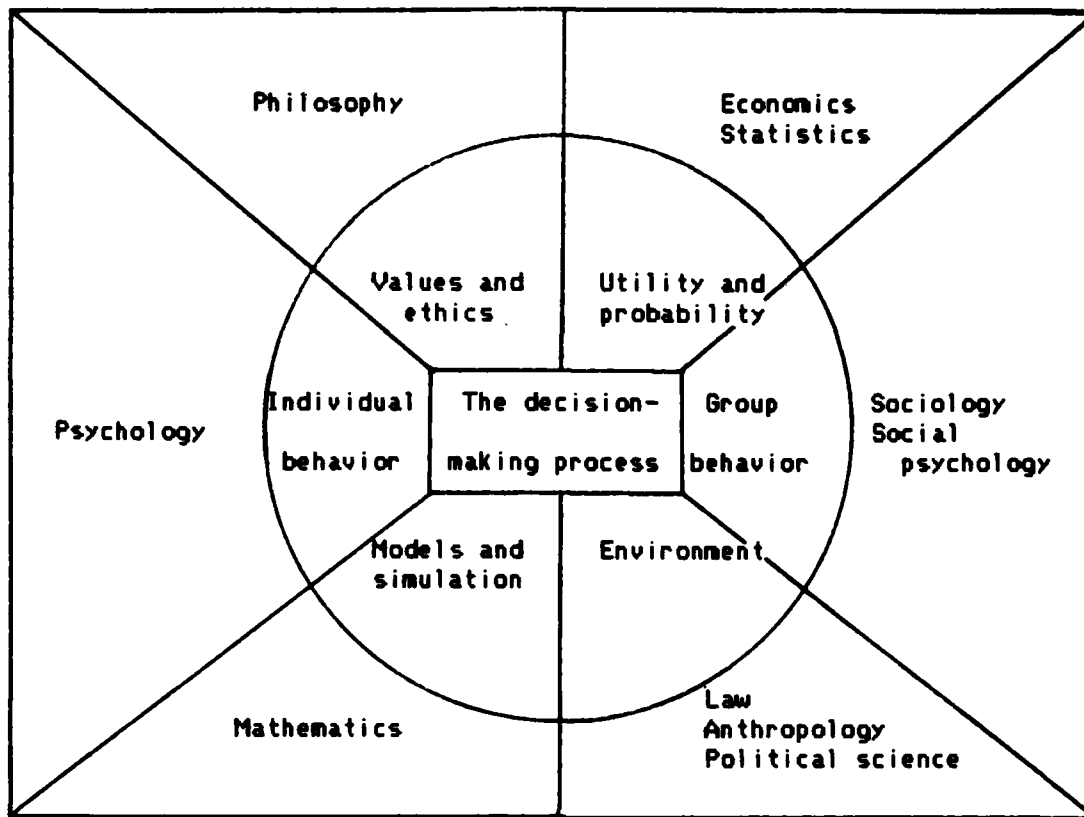

Figure 2-2. The Interdisciplinary Framework of Decision Making
(Harrison, 1981: 63)

the rational manager view, the "satisficing" (process-oriented) view, the organizational procedures view, the political view, and the individual differences view. The first four reflect an organizational or managerial look at the decision process. The last view looks at the decision in a task independent manner, focusing on the actual decision maker (Keen and Scott-Morton, 1978: 62-63).

These views range from normative to descriptive. The normative approach is outcome-oriented. Quantitative models and complete characterization of parameters are used to focus on predicting the outcome in

order to understand the process. A process orientation marks the descriptive approach. Qualitative models are used to understand the influences acting on the decisionmaker and predict the outcome (Zeleny, 1982: 85; Thierauf, 1982: 96-97). Each of the views will be discussed in more detail in the following paragraphs.

The rational view is the normative perspective of decision making, how decisions should be made. Harrison states that it is structured to the point of being mechanistic. He indicates that a common form consists of a single decision maker with one quantitative objective. The decision maker has complete knowledge of the alternatives and the states of nature, which are finite and enumerated. The decision maker chooses the best course of action (Harrison, 1981: 53-54). "The rational concept defines the logic of optimal choice; this remains theoretically true, even where it is descriptively unrealistic (Keen and Scott-Morton, 1978: 65)." Huber points out that this view is inadequate for the design of DSS (Huber, 1980: 47).

The "satisficing" view relaxes the strict rules of the rational model. Harrison attributes the development of this view to the research of Cyert and March, as evolved and broadened by Simon (Harrison, 1981: 57-58). In reality, rarely can we enumerate all the alternatives and their consequences. Generally, a moderate search is conducted to find an acceptable solution. The search is based upon heuristics which are "good enough" most of the time (Keen and Scott-Morton, 1978: 66). "Heuristics reflect 'bounded rationality.' That is, they are a compromise between the demands of the problem and the capabilities and commitment of the decisionmaker (Keen and Scott-Morton, 1978: 66)." This

model has been useful in interpreting a wide variety of organizational decisions (Huber, 1980: 48).

The organizational procedures view has a managerial emphasis looking for objective-oriented outcomes and long-term results (Harrison, 1981: 61). Huber discusses programs and programming. Programs are the policies and procedures, conventional practices, norms, formal and informal structure, and other constraining factors within an organization. Programming relates to the cognitive and motivational responses of the decision maker arising from his training, education, and experience (Huber, 1980: 49). "Organizational decisions are consequences of the programming and programs of the units involved (Huber, 1980: 49)." Each unit has its own goals and programs, looking at problems with its functional perspective. A DSS can integrate these units and their perspectives (Keen and Scott-Morton, 1978: 69-70).

The political view sees "organizational decisions [as] consequences of the application of strategies and tactics by units seeking to influence decision processes in directions that will result in choices favorable to themselves (Huber, 1980: 47)". The process involves a multiplicity of goals and interests. Power, persuasion, accommodation, bargaining, compromise, and advocacy are characteristics of the process as consensus is built to find an outcome which is acceptable to the many constituencies involved. This process represents the art of the possible with an emphasis on incremental short term changes which move away from known ills rather than towards a goal (Keen and Scott-Morton, 1978: 70-72; and Harrison, 1981: 59-60). "If one is interested in building systems to be USED, the political dimension is an important constraint --

and OPPORTUNITY (Keen and Scott-Morton, 1978: 72)."

The individual differences view postulates that each decision maker is unique and hence focuses on his individual traits and abilities. The outcome of the decision process is strongly influenced by these personalized characteristics. Keen and Scott-Morton outline two approaches: cognitive complexity and cognitive style. Cognitive complexity deals with an individual's ability to structure information and the amount of information he can effectively deal with. There is an optimal amount of information, both too little and too much information are dysfunctional. Cognitive style looks at the decision maker's problem solving process (Keen and Scott-Morton, 1978: 73-76). Henderson and Nutt review several frameworks for decision style concentrating on the "dimensions". They conclude that "Each framework has common as well as unique interpretations. Attempts to correlate the dimensions of these frameworks have produced only limited basis for integration (Henderson and Nutt, 1980: 373)." Also, they find that decision style has a considerable influence upon the decision making process (Henderson and Nutt, 1980: 384).

These views of the decision process are not mutually exclusive. In analyzing the decision process the applicability of each must be assessed. In the case of the development of technically feasible SATCOM alternatives, emphasis will be placed upon the first four views. The large number of people involved in the decision process and the change in personnel characteristic of the military environment make the contributions of the individual differences perspective difficult to determine.

Iterative Design

"The label 'Support System' is meaningful only in situations where the 'final' system must emerge through an adaptive process of design and usage (Keen, 1980a: 28)." This adaptive process is called iterative design and refers to the quick development of an initial system which evolves and grows with use and understanding. Iterative design is particularly suited to the SATCOM requirements task. Although working within the established DPMS, SATCOM requirements is a new task within DCESR and hence the decision process will evolve with experience. The DSS must also be capable of changing to continue to support the decision process.

Sprague and Carlson believe that "one of the pillars on which the success of DSS rests is the iterative development (Sprague and Carlson, 1982: 37)." Keen supports this, indicating that a review of DSS case studies found the system development life cycle to be inappropriate (Keen, 1980a: 27). The iterative approach is more effective for implementing an analytic model (Alavi and Henderson, 1981: 1321). An analytic model will be used to evaluate technical feasibility. For these reasons, the iterative design approach will be followed in this paper.

Peter G.W. Keen provides four reasons for using the iterative process. The semi-structured nature of the decision process means that those involved may be unable or unwilling to provide details necessary for complete functional specifications. Users and designers may not know or understand what is needed. An initial system allows a common reference for reactions by both parties. The third reason for iterative design is that the user's decision process may be shaped by the DSS,

which can stimulate learning, innovation, and insights. Finally, the DSS must allow the user to personalize the process. Thus the DSS must adapt to changes in user preferences and to new users (Keen, 1980a: 28).

The iterative design consists of four steps:

1. Identify an important subproblem.
2. Develop a small but usable system to assist the decision maker.
3. Refine, expand, and modify the system in cycles.
4. Evaluate the system constantly (Sprague and Carlson, 1982: 140).

Feedback from the evaluation step can refine the initial module of the DSS, assist with other follow-on parts, or lead to the scrapping of the "prototype". With each iteration an important but distinct part of the decision process is supported by a new module. The stand alone modules are strung together to form the DSS (Hurst et. al., 1983: 125).

The modular nature means that new functions and capabilities can be added without redesign or reprogramming (Moore and Chang, 1983: 184).

Keen and Scott-Morton discuss a pre-design cycle for each iteration. In particular, the pre-design cycle looks at decision analysis. The intent is to determine key decisions, develop normative models, and select areas for support (Keen and Scott-Morton, 1978: 174). This is the area on which this paper focuses, what the DSS should do, not what it should look like. The initial analysis will provide sufficient information to build a nucleus for the DSS (Moore and Chang, 1983: 184).

It should be noted that with iterative design "the system can never be final; it must change frequently to track changes in the problem, user, and environment because these factors are inherently volatile (Sprague and Carlson, 1982: 132)." The iterative design approach may benefit from user tutorials, These tutorials allow new users to

develop an understanding of the models and to use the capabilities of the DSS to personalize the decision process. Tutorials allow others to refresh their knowledge (Sprague and Carlson, 1982: 144). Tutorials could also provide a means to improve the user's decision process. According to Stabell, this improvement in decision making effectiveness is a goal of DSS (Stabell, 1983: 233). Tutorials will be a definite requirement for the DSS to support SATCOM planning. The tutorials will allow others in the DCESR office to learn the DSS and will serve as a means to explain to operational Commands the steps in developing operational requirements reflecting their SATCOM needs.

In the next section the actual means for identifying the specifications for each iteration will be discussed. This research effort uses the procedures to determine the specifications of the kernel system.

Systems Analysis

Systems analysis identifies those functions the DSS should have to support the SATCOM planning decision process. There are three techniques which could be used. The intent of this section is to outline each technique and indicate why the selected method was chosen.

The traditional approach to systems analysis is the systems development life cycle. There are six distinct phases which act as management control points. The six phases are feasibility study, systems analysis, systems design, equipment selection, systems implementation, and periodic review. Each phase has definite objectives and the analysis does not proceed to the next phase until all objectives have been met. There are two advantages to this approach. It provides a structure for

analysis and control of the project and ensures proper and responsive communications between management, the user, and the analyst (Thierauf, 1982: 118-120).

This technique is not amenable to the iterative design approach. The intent is to completely specify a final system. The very structure makes it inflexible, and for this reason is not selected for use in analyzing the SATCOM planning process. As pointed out above, Keen's research indicates the system development life cycle to be inappropriate for DSS (Keen, 1980a: 27).

Bahl and Hunt propose a task analysis methodology to study the system requirements for a DSS. This methodology encompasses three forms of analysis: event analysis, participant analysis, and decision content analysis. "Events are identifiable (and inferable) activities in a decision-making process (Bahl and Hunt, 1984: 122)." Event analysis investigates the order and significance of events. Participant analysis investigates who was involved in the decision process as well as their properties, roles, and relationships. Decision content analysis is the key step. A micro-level model of the decision process is developed and used to identify factors defining and influencing the decision maker's behavior. Developed and used to study complex public decisions, the technique is too detailed and formal to use in determining initial DSS requirements.

Sprague and Carlson present a process independent, user-oriented method of establishing system requirements (Sprague and Carlson, 1982: 15). They call the method RDMC, which stands for representations, operations, memory aids, and control mechanisms. Representations are con-

ceptual looks at the information used in the decision process. Representations may be mental or physical. Physical representations in the form of graphs, charts, tables, etc. allow communication. These representations can be linked to the intelligence, design, and choice phases of the decision making process. Representations can be used to input or output data as well as to invoke operations (Sprague and Carlson, 1982: 102).

Operations are the methods used to manipulate representations. Operations may be used to manipulate more than one activity. Ideally, operations are not ordered or structured, allowing the decision maker to tailor the order in which operations are used to his own style. Operations may range from complex algorithms, such as linear programming, to simple rules of thumb (Sprague and Carlson, 1982: 103).

Memory aids provide the decision maker a means to store, recall, and work with data. Sample memory aids include: data bases (internal/external, raw/aggregated), workspaces, links (to pass work, or parts thereof, between the current process and others), triggers (checklists), and profiles (defaults and status information). Control mechanisms allow the decision maker to utilize representations, operations, and memory aids to synthesize a personal decision process. Aids to understand the mechanics of operating the DSS (menus etc.) and aids to support learning and explanation are control mechanisms, as are the ability to combine operations and change defaults (Sprague and Carlson, 1982: 104-107).

At this point we switch from the DSS to the decision to be supported. The following sections look at the technical aspects of SATCOM de-

sign. The methods of evaluating SATCOM performance will be discussed in the next section.

SATCOM Technical Analysis

In surveying the technical literature on satellite communications, three general analytical methods emerged. These methods are simulation, link budget analysis, and specific application/theory. This section will discuss each method briefly and select that one which offers the best potential for development as the kernel of the SATCOM planning DSS.

The specific application/theory method is typified by the papers written for technical journals (for example Abramson, 1984; Feher et al., 1983; and Van Trees, 1979). These papers study one narrow aspect of the SATCOM design, usually from an engineering perspective. The large number of techniques in these papers which would be required to analyze a SATCOM system, the detail, and the complexity of the techniques were reasons why this approach was not selected.

Simulation is the second technique. The January 1984 issue of the IEEE Journal on Selected Areas in Communications was devoted to "Computer-aided Modeling, Analysis, and Design of Communication Systems" (Balaban, Shanmugan, and Stuck, 1984). Shanmugan points out that SATCOM systems are complex in nature, include non-linear devices, suffer from transient effects, and undergo more types of interference than terrestrial communication systems. These factors make it difficult to estimate system performance in a closed form with analytic techniques. Simulation can give accurate estimates of system performance for individual links and for networks (Shanmugan, 1983: 323). There is, however, no

standard for simulation. Current communications system simulation packages are detailed (working to the block diagram level) and require at least a stand-alone mini-computer system (Shanmugan, 1983: 325). For these reasons this technique was not chosen.

The last method of estimating SATCOM system performance is that of link budget analysis. This technique is analytically straightforward, tracking gains, losses, and sources of noise throughout the SATCOM system. The link budget identifies the main system parameters and their contribution to system performance (Sklar, 1979: 1).

Link budgets:

- a) Are useful for rapidly determining top level resource allocations
- b) Indicate hardware constraints
- c) Help to predict system performance, weight, size, and cost
- d) Allow recognition of the design ground rules and of system design flows
- e) Highlight reasonable design tradeoffs
- f) Illustrate areas of dependence
- g) Help to predict system availability
- h) Highlight system nuances
- i) Facilitate changing configurations
- j) Can serve as the basis for an optimal design search (Sklar, 1979: 1).

Link budget analysis is covered in all texts on SATCOM (for example: Feher, 1983; Gagliardi, 1984; Spilker, 1977; and Wu, 1984). A link budget will be calculated during the design of any SATCOM system. This fact plus the straightforward method in which it is calculated make it an excellent technique to use as the kernel for the DSS. A specific formulation will be developed in Chapter 4.

MS/OR Techniques

In discussing computer-aided systems engineering, Eisner identifies

issues and questions which are pertinent to the design of any system. Two of these questions are particularly germane to the SATCOM design problem: which system requirements are satisfied and which requirements are technically interdependent. He also points out that the fundamental parameters of systems engineering are technical performance, cost, and schedule (Eisner, 1984: 15). Technical performance is the focus of DSS which will be proposed during this research. Operations research and management science techniques provide methods to optimize technical performance and to answer the two questions posed above.

This portion of the literature will cover those areas that are applicable to SATCOM design. Beginning with an overview of the design process, a method of determining satisfaction of customer requirements is presented as well as a means of determining the requirements of the user and their relative importance. The next technique discussed provides a method of finding interdependence between the user's requirements and to prioritize the design process. These two steps, the determination of user requirements and the development of an initial technical specification, are the main task of DCESR and the area the DSS is to support. The section concludes with a review of mathematical techniques that have been applied to satellite systems.

A flowchart of the design process for a large electronic system is given in Figure 2-3. It illustrates the key role of the user throughout the process and the degree of feedback which shapes the final design. The process begins with a user-planner dialogue to set performance objectives and requirements. These objectives and requirements are not definite, often based upon estimates of future developments and the

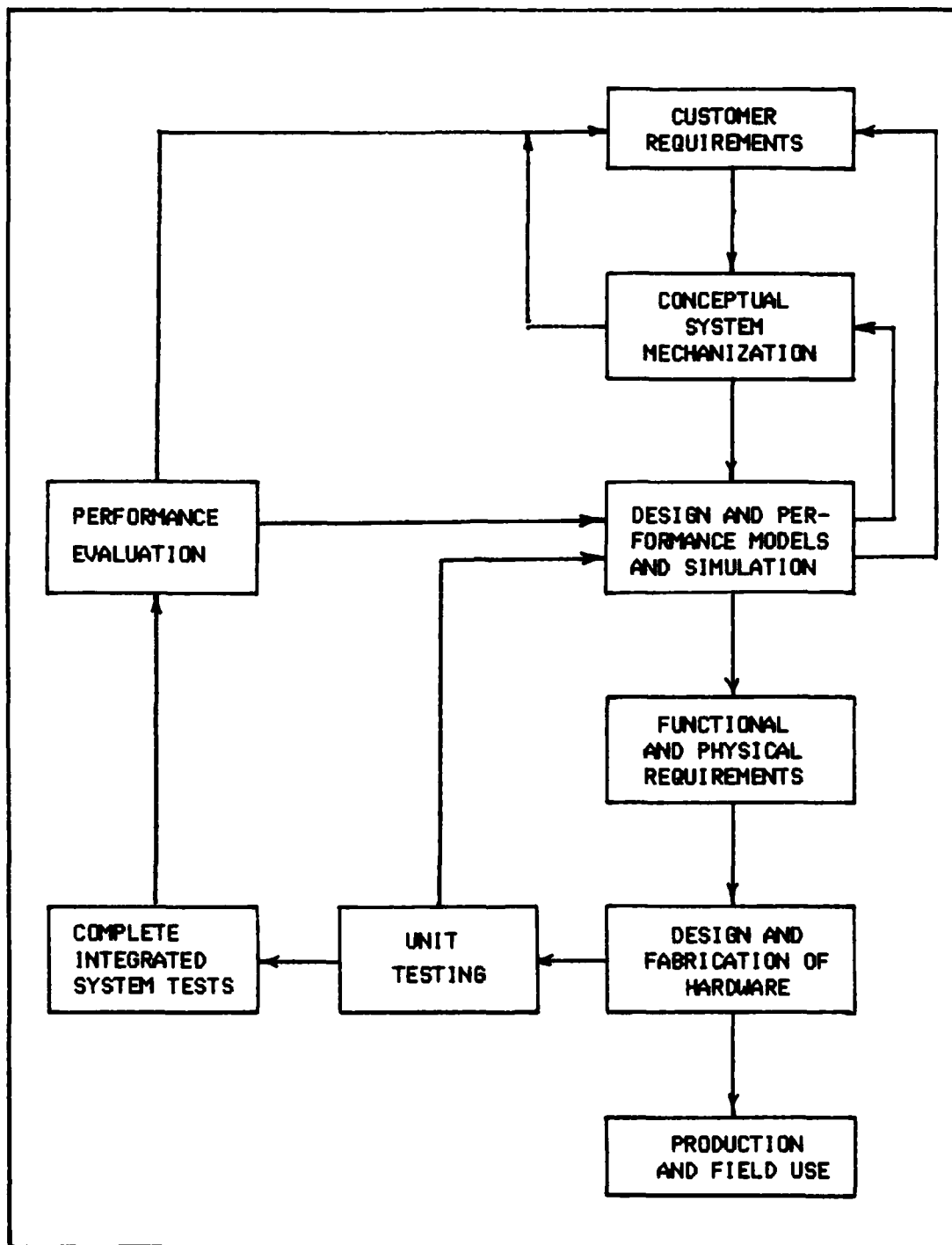

Figure 2-3. System Design and Testing Flow Diagram
(Hovanessian, 1975: 95)

user's desires. Both sides work to progressively refine these initial requirements (Hovanessian, 1975: 94).

In addition to the difficulty of foreseeing the availability of components, one is faced with the inherent unpredictability of design activity. In many cases, solutions can be reached only through a process of trial and error. Often these solutions create new approaches; less frequently they lead to innovations that change the entire design concept (Hovanessian, 1975: 94).

In the SATCOM design process, DCESR acts as the interface between the user and the design engineers. DCESR assists the user identify and quantify his requirements, acts as the system proponent in the DPMS, and serves as the user's representative to the design engineers. Throughout the process, DCESR must represent the user's desires. Hovanessian points out that cost effective systems don't always please the user. Satisfying life cycle costs is only a small design criteria for the optimum system. He proposes the use of customer-acceptance parameters to guide optimum system design. The parameters are weighted to reflect the relative importance of each parameter to the user and the degree of overlap between parameters. Importance to the user increases the weight while overlap decreases the weight (Hovanessian, 1975: 100). Sample customer-acceptance parameters are shown in Table 2-1.

Thomas Saaty has developed a method to determine and weight criteria. The technique is called the Analytic Hierarchy Process (AHP).

The AHP can be used to stimulate ideas for creative courses of action and to evaluate their effectiveness. It helps leaders determine what information is worth acquiring to evaluate the impact of relevant factors in complex situations. And it tracks inconsistencies in the participants' judgements and preferences (Saaty, 1982: 25).

The technique is based upon the use of a hierarchy, "the single most powerful mental construct for studying complex systems (Saaty, 1983: 141)." Starting at the top goals are decomposed into ever more

Table 2-1. Sample Customer-Acceptance Parameters
(Hovanessian, 1975: 100)

<u>ITEM</u>	<u>PARAMETER</u>	<u>WEIGHT</u>
1.	Life cycle cost	20
2.	Maintenance Skills	5
3.	Maintenance Personnel (numbers)	5
4.	Availability	15
5.	MTBF per MTTR	10
6.	Maintenance Manhour per Operational Hour	10
7.	Spares	5
8.	Operator Approval	10
9.	Degree of Automation	10
10.	Improvement over Previous System	10
		100

definite criteria. At the bottom alternatives and elements under which they can be compared are identified. This structure links elements at the bottom through the levels to the objectives at the top. Matrices and a ranking scale are used to do pairwise comparisons at each level. These manipulations can be used determine priorities as well as the consistency of decision maker (Saaty, 1983: 141). This technique can be used to determine customer-acceptance parameters for SATCOM design and their relative weights.

The AHP technique has already been used by the Canadian Forces. In

developing the evaluation plan for a new shipborne anti-submarine warfare helicopter, AHP was used to:

- a. define criteria against which alternative contractor proposals are to be evaluated with respect to vehicle effectiveness;
- b. organize criteria into a value tree;
- c. assign weights to indicate the relative importance of each criterion;
- d. check weights for consistency; and
- e. delineate a scoring method for evaluating proposals against each criteria (Krant, 1985: 2).

Engineering design of complex systems requires specification of many variables. There are often several interdependencies, requiring some variables to be known or assumed before others can be determined. These interdependencies lead to an ordering which contains circuits, i.e. A depends upon B and B depends upon A (Steward, 1981: 71). "Circuits are usually handled by making estimates for some of the variables to make a preliminary design, then using the results of the preliminary design to confirm or refine these estimates. This is the process of design iteration (Steward, 1981: 71)."

Steward proposes a method called the design structure system to identify interrelationships between the variables and to identify where estimates are required. The designer first develops a variable list noting which variables must be established before another one can be determined. The precedence assigned to a variable may be based upon analytic/mathematical relationships or the qualitative judgement of management or the engineer. These precedence relationships are then put into matrix form. By rearranging the matrix the designer can determine the order of design and smallest subset of variables which must be estimated before a design iteration can be made.

Traditionally, the emphasis of satellite communication has been on

technological advancement, while the application of optimization methods to satellite systems has lagged behind (Wu, 1984: 503). Wu provides an overview of mathematical programming techniques which are applicable to the design optimization of SATCOM systems. He covers six techniques in the context of fifteen sample problems. Linear programming is discussed and the simplex and network algorithms developed. Simplex is used to assign satellite channels in a manner to minimize cost. Maximizing transmission capacity and finding the minimum delay are given as examples of applications of networking. Carrier assignment to a transponder and maximization of the minimum received carrier level are solved by nonlinear programming techniques. Integer programming is applied to the minimization of the number transponders necessary to meet the capacity requirements of a number of earth stations. Dynamic programming may be used to study path delay over several links. Stochastic processes are combined with the other techniques to reflect the risk and uncertainty of the real world. Queuing theory is another aspect of stochastic programming which can be used to investigate the delays experienced by messages passing through a system. Combinatorial programming methods are applicable to the design of synchronization sequences and to traffic assignment (Wu, 1984: 439-506).

Management sciences/operations research optimization methods have not been extensively used in DSS. Joyce J. Elam points out that these methods use intricate models which require specialized knowledge. These models have been criticized as too structured (Elam and Schneider, 1983: 2-3). Recent advances with many useful features are capable of dealing with the broader constraints found at the management control level. In-

tegrating optimization models into decision support systems with appropriate interfaces will allow a manager to select the 'best' plan among different scenarios and test the plan under 'what if' conditions. The use of optimization DSS is applicable to the area of management control (Elam and Schneider, 1983: 6-7).

To implement any of the above techniques, care must be taken to separate the complexity and theory of the algorithms from the decision maker. The DSS approach "translates complex analytic models into usable and useful techniques for decision makers (Keen, 1980b: 41)." Any analytic technique can be used in a DSS provided it can be: 1. related to decision process, 2. expressed in familiar terms, and 3. made part of dialogue (Keen, 1980b: 41)."

Optimization-based DSS could provide a useful tool to the DCESR staff. The decisions to acquire MILSATCOM systems in support of operational tasks represents management control function. A DSS would provide a means to evaluate the many trade-offs in planning MILSATCOM systems.

III. The Decision Process

Background

In this chapter the decision process by which SATCOM resources are acquired and allocated will be examined. I begin with an overview of the Defence Services Program (DSP). Within this environment, a flow-chart of the SATCOM planning decision process is developed. The decision process is then analyzed in terms of decision structure, level of decision-making, independent/interdependent decisions, decision-making phases, and the different perspectives of decision-making.

The DSP is a detailed plan of the costed activities and resource allocations for the Department of National Defence. The Defence Program Management System (DPMS) provides the procedures necessary to add, delete, or modify activities within the DPMS. Figure 3-1 shows the five phases in the DPMS. Shown sequentially for convenience, it is a repetitive process with continual feedback and interaction between all phases.

Each Phase represents a level of commitment by DND, ranging from conceptual to funded projects. A phase begins with a lead document (either a separate statement of requirement or the approved principal document from the previous phase). A phase progresses with studies to refine the project and terminates with the principal document which seeks formal approval to proceed to the next phase. As the process progresses, the detail and precision of the project increases. At the same time, the number of interrelationships between different agencies involved in the project grows.

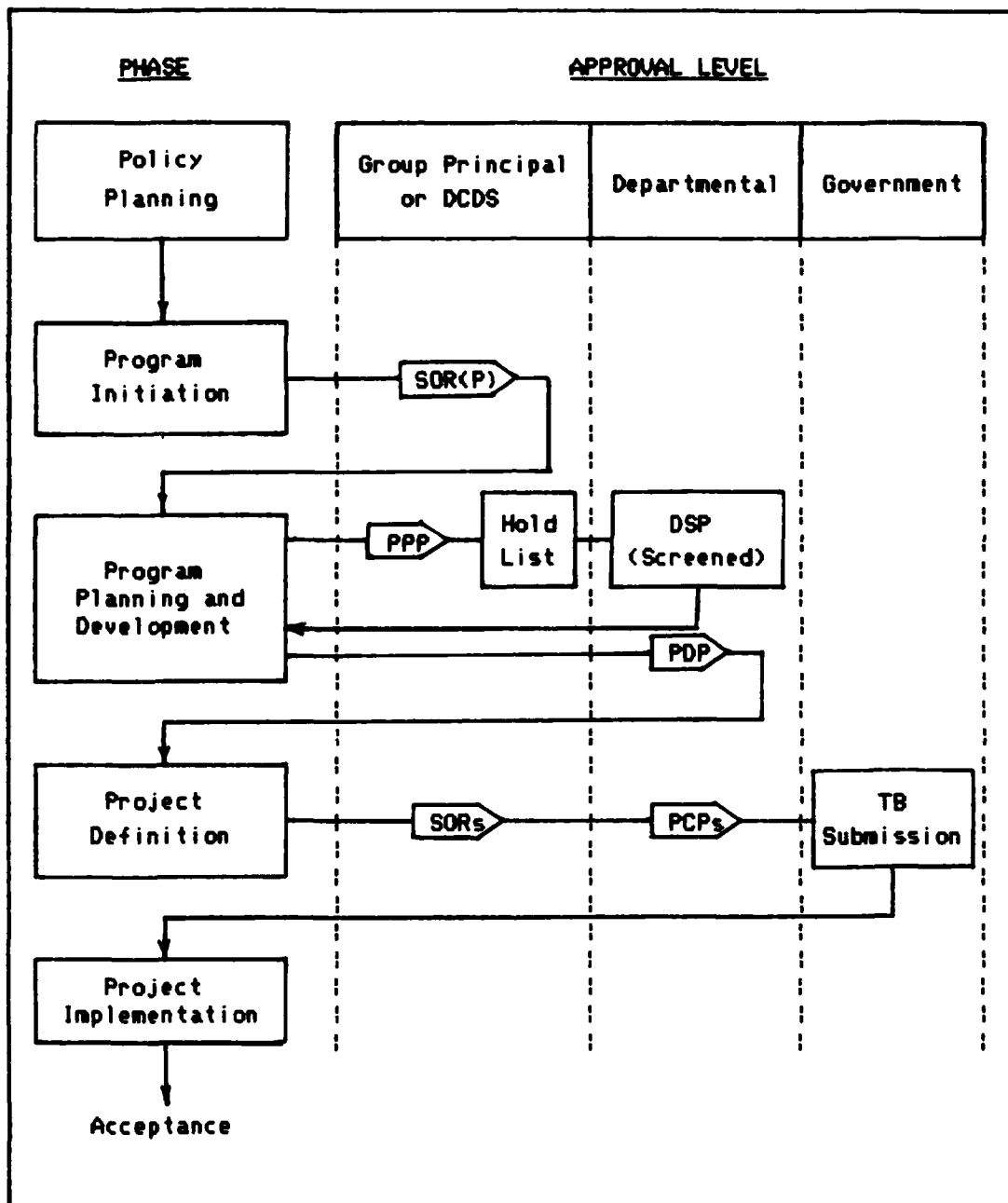

Figure 3-1. The DPMS Process (C Prog 500, 1981: Ch2, 2)

This is the environment within which the DCEsr decision process operates. DCEsr can be working at any level to prepare the necessary

documents for the DPMS. DCESR may be the sole developer of a SOR(P) in the early phases of the process or be working with a number of other Directorates in later phases. The aim of the staffing process in DCESR is to prepare or assist in the preparation of the documents which are used in the DPMS. The MILSATCOM DSS supports decisions in this area.

The Decision Process Model

The design process for MILSATCOM systems is similar to that for the design and production process of a large electronic system, such as that shown in Figure 3-2. The flowchart illustrates the feedback inherent in the design process and the move from general to specific as the design is developed.

Two other points should be made about the process. The first is the degree of user involvement. The user is actively involved throughout, or his interests are represented at all stages. The second point is that the system is conceptually designed first. That is to say that a rough first fit is made, then refined as the design process proceeds.

In the first area, the system designer must constantly be aware of the user's desires and not get lost in the technical elegance of the system. One method of doing this would be the use of "customer-acceptance" parameters (Hovanessian, 1975: 100). This would remind the designer that often availability, maintenance, sparring, and operator acceptance are more important to system success than cost effectiveness. In order to determine those factors that are important to the SATCOM user, a method is required to select the appropriate criteria and weight them according to their relative importance.

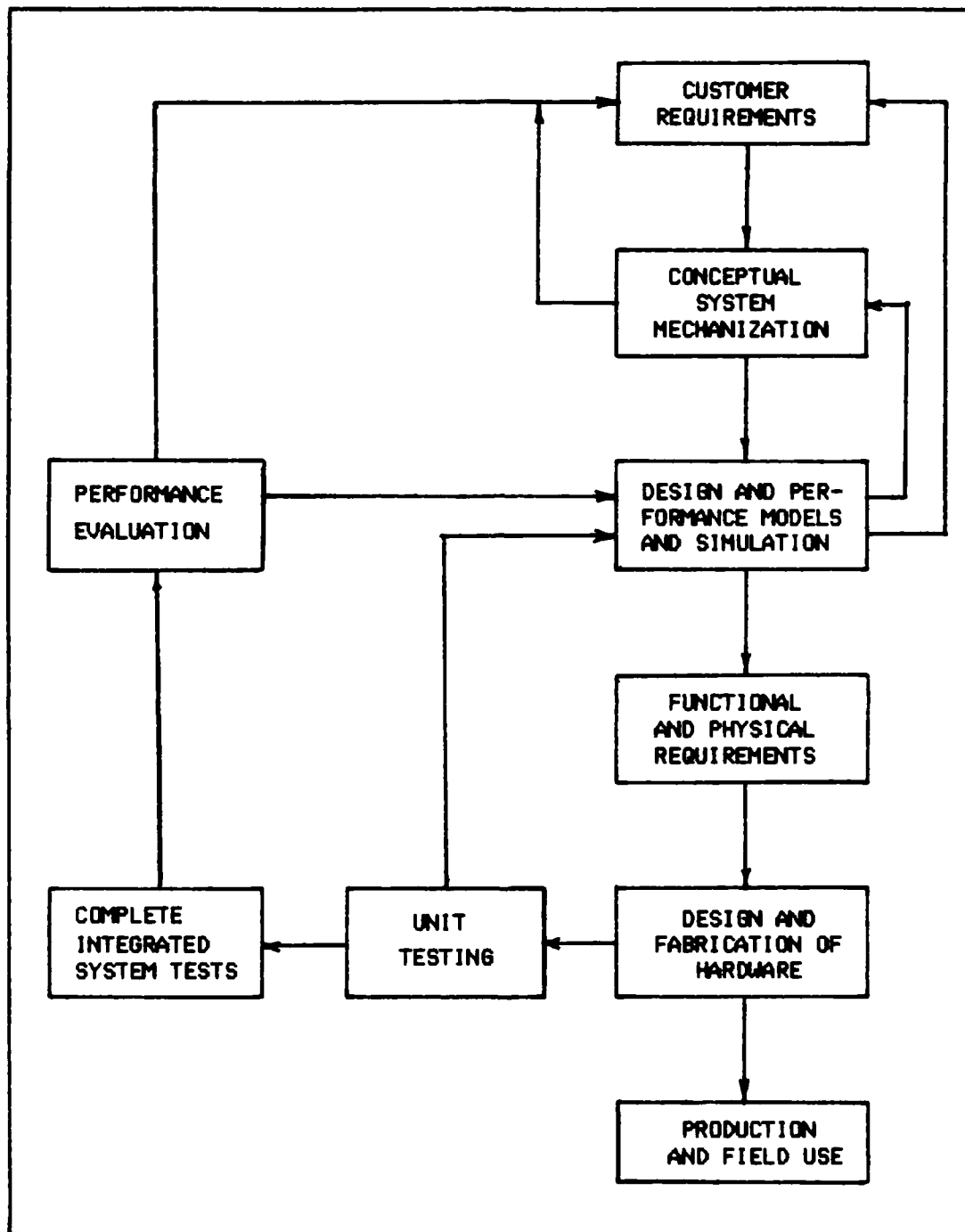

Figure 3-2. System Design and Testing Flow Diagram
(Hovanessian, 1975: 95)

Saaty's Analytic Hierarchy Process (AHP) could provide a means of eliciting customer-acceptance parameters and for determining their weights. This approach would also provide consistency throughout the DPMS design and acquisition process. This technique has been used by the Canadian Forces to evaluate contractor proposals in major equipment acquisition programs (Krant, 1985). AHP also offers the advantage that it is capable of determining preferences and weights in a group setting. This would allow the technique to be used to determine customer-acceptance parameters and their weights when more than one operational user is involved (i.e. combined Army, Navy, and Air Force systems).

The second point from the flowchart deals with the initial conceptual mechanization of the SATCOM system. The designer must determine which design variables are known and which are unknown. He must then determine which variables are interrelated and thus which must be estimated to produce the initial design mechanization. This isolation of the variables to be estimated can be done using Steward's Design Structure System (Steward, 1981). This method would also show the effects changes in one area have on all other variables.

The above considerations lead to the formulation of the decision process as shown in Figure 3-3. The twin inputs of user requirements and departmental policy reflect the fact that departmental policy may set some variables. In this case it is the responsibility of the DCESR staff to ensure that the user understands the policy and that the design reflects existing policy.

Based upon the user's requirements, policy, and any existing hardware, the SATCOM designer determines what information he has. This in-

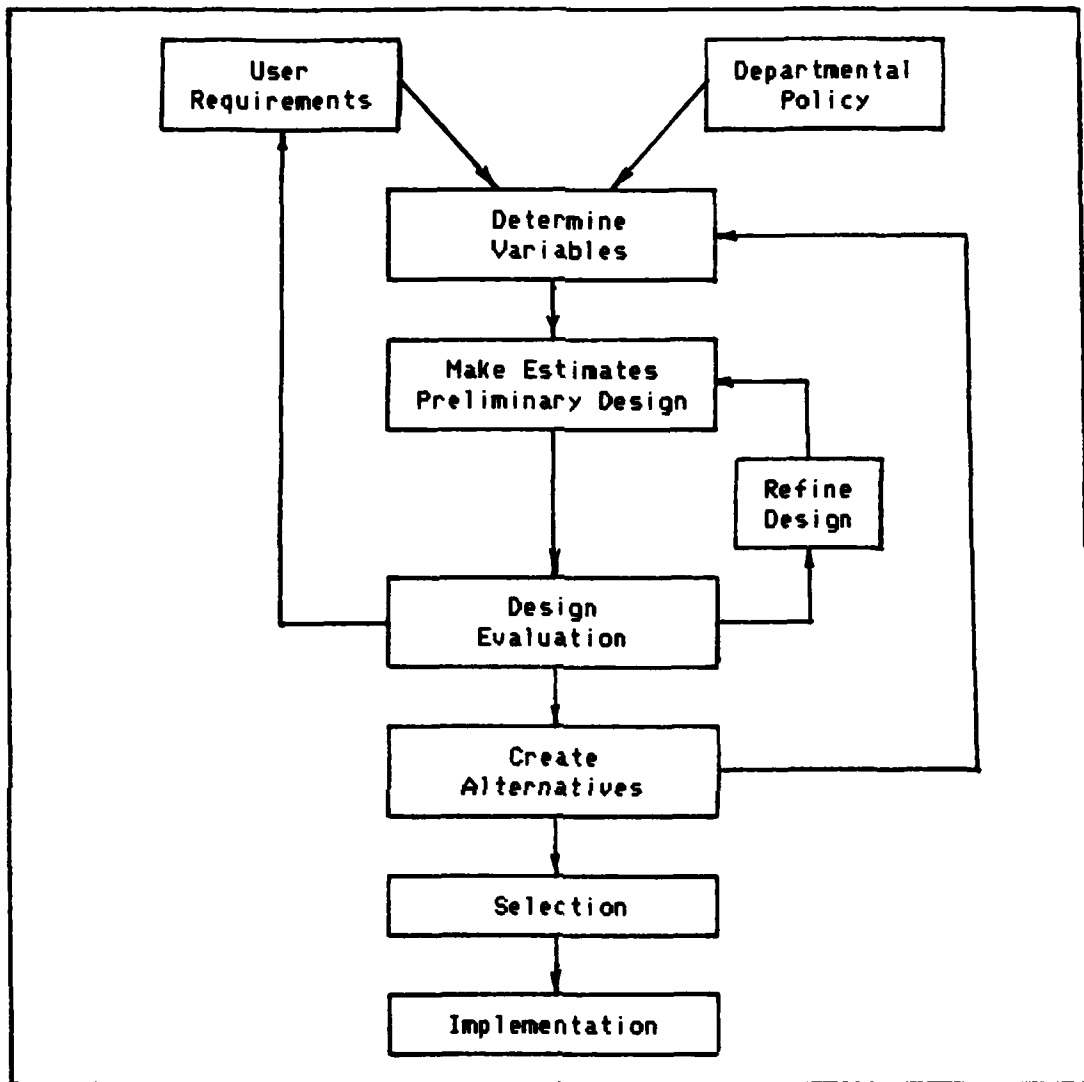

Figure 3-3. The SATCOM Decision Process

formation allows the designer to determine what information he needs to make an initial design. With estimates and assumptions a preliminary design is formulated. This initial design is evaluated in terms of performance, complexity, cost, and the user's requirements by both the designer and user (preferably). Based upon this evaluation the user can

adjust his requirements and the designer can tighten his estimates and reduce his assumptions. The result of this process is an adjusted set of variables and a refined design. This continues until a satisfactory, feasible design is achieved.

The linkage between Create Alternatives and Determine Variables reflects the case where there may be two or more options for one variable. Here the designer develops a technically feasible system for each option. Each system is then evaluated against the user's requirements to determine which is better. An example occurs when determining which multiple access technique to use in a SATCOM system. In general, frequency division multiple access is a simple system but does not make the most efficient use of the satellite transponder. Time division multiple access makes more efficient use of the transponder but there is increased system complexity. There is a loss in system capacity and increased system complexity when code division multiple access (spread spectrum) is utilized. The DSS provides a technically feasible system for each option. The user's requirements would then be used to decide which alternative is best.

In the context of this research the selection and implementation occur within the DPMS. These blocks reflect the output of the DSS process in the form of technically feasible alternatives. The application of follow-on modules (such as cost-benefit and customer-acceptance parameters) to the alternatives would allow selection of the desired course of action. Implementation in Figure 3-3 denotes the preparation of the required decision document (PPP, PDP, or PCP).

Analysis of the Decision Process

In Chapter Two, five objectives of a DSS were used as a structure for a review of the literature on decision making. These objectives are:

1. A DSS should provide support for decision making, but with emphasis on semistructured and unstructured decisions...
2. A DSS should provide decision-making support for users at all levels, assisting in integration between the levels whenever appropriate...
3. A DSS should support decisions that are interdependent as well as those that are independent...
4. A DSS should support all phases of the decision-making process...
5. A DSS should support a variety of decision-making processes but not be dependent on any one (Sprague and Carlson, 1982: 26-27).

This same structure will be followed here to analyze the decision process for SATCOM design.

The SATCOM design process is a semistructured task. The analytic techniques and engineering relationships used in the design of a SATCOM system represent the structure in the task. The unstructured portion pertains to the trade offs made in light of the requirements for the SATCOM system. Thus the DSS must provide models of the engineering relationships. These allow the decision-maker to determine the technical feasibility of a particular configuration of parameters that he has selected to meet the requirements.

The SATCOM DSS will be used mostly at the management control level. The output of the kernel DSS is a technically feasible SATCOM system which will be costed and entered in the DSP. It is the DSP which is the DND management process to acquire and allocate resources. The efficient acquisition and usage of resources is the purview of management control. The DSS has the potential to be used at the strategic level. Using a

set of typical values, a representative system could be designed. The effects of varying one or two variables could then be determined. From this analysis policy guidelines could be set. For example, transponder utilization versus data rate could be determined for each multiple access technique. Comparison of these curves could lead to a policy establishing the access technique to be used for specified data rates.

The third objective pertains to the number of people involved in making the decision. In the Headquarters many Directorates must work together when staffing requirements and acquiring resources. The DSS allows the DCESR staff to evaluate proposals and their effect upon the SATCOM system's technical performance. There will be independent decisions during the initial development of technically feasible designs. Interdependent decisions will occur as these designs are staffed and refined.

The model of the SATCOM decision process contains all phases developed earlier: intelligence, design, choice, implementation, and control. The implementation phase represents the production of the principal document to end a stage of the DPMS. The control phase is implicit and is reflected by a re-evaluation of the principal document if it is not accepted or by the beginning of a new cycle if the document is accepted. The DSS Kernel is primarily concerned with the intelligence and design phases. This reflects its initial mandate, the creation of technically feasible SATCOM systems. The addition of follow-on modules such as the AHP or the design structure system would enhance the DSS for the first two phases. Costing models and the use of the AHP for evaluation of alternatives would increase the DSS's support to the choice and

implementation phases.

The last DSS objective reflects the decision-making perspective. The Rational view is represented by the DPMS, which is an economic budgeting method for "rational" decision-making. Cost benefit analyses are a key input to the DPMS. The Satisficing view brings in factors such as budgetary limits, the availability of existing SATCOM equipment, and the number of Directorates involved, each with their own conflicting criteria.

The Organization Procedures view is also evident. Decisions within the Headquarters are governed by procedures, SOP'S and policy. Individual's will reflect their training and education, as well as, the "programming" they have received by experience and environmental backgrounds.

The Political perspective will have a definite impact upon the decision process. The competition for funds among the environmental and organizational elements is a factor in the process. Each Directorate involved in the process will be looking to ensure that their interests are included. In the larger context, major projects require Cabinet approval. This can mean public scrutiny and the resulting forces from different interest groups. Political factors such as Canadian manufacturing content and regional economic development must also be considered.

The Individual Differences perspective will impact the decision process. Personnel in NDHQ tend to rotate quickly. There may be two or three groups of people involved in the decision over the duration that a proposal is developed from concept to project implementation.

Of the five perspectives, the first four represent the major means of analyzing the decision process. The individual differences should be accommodated by the iterative design. Additional capabilities should be included in the DSS to allow the individual to personalize the DSS to his cognitive style.

This chapter focused on the key aspect of decision support, the decision process. Within the Defence Program Management System, a model of the SATCOM design process was developed. It emphasized user involvement and an evolutionary design development. The model was then analyzed against the objectives of a DSS. This analysis indicates that the SATCOM design process is suitable for a DSS. A kernel DSS would be an asset to the DCESR staff. The next chapter will develop the analytic model which will be the kernel of the DSS.

IV. SATCOM Link Analysis

Introduction

In this chapter I develop the analytic tool which has been selected as the kernel of the DSS. This tool is the link analysis. I will begin by discussing the value of link analysis. An overview of the gains, losses, and noise sources which are found in a SATCOM system is presented. The basic link budget is developed from this overview and each of the major components is detailed. An initial discussion of the effects of multiple signals is presented as well as remarks about the link budget tradeoffs which can be made in SATCOM design.

The last sections of the chapter deal with sharing the satellite resources among several users. Methods of multiple access (frequency, time, and code division multiple access) and assignment (random, fixed, and demand assignment) are discussed. Each of the multiple access techniques is then discussed in terms of its effect upon the link budget. The chapter concludes with a summary of the link analysis parameters required in the kernel DSS.

Link Budget

The link budget is a means of determining the signal power and noise power at any point in a SATCOM link. A communication link is the path over which information is passed from the source to the destination. The link includes all operations and transformations along the path. A typical satellite link block diagram is given in Figure 4-1.

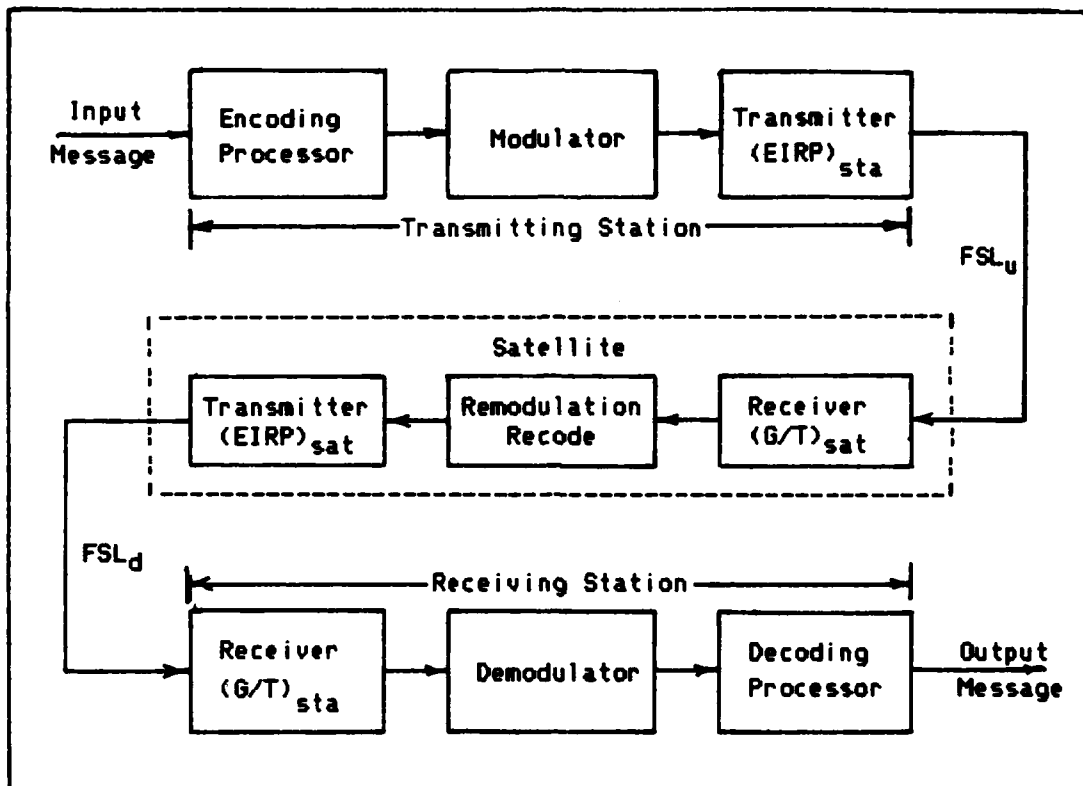

Figure 4-1. Satellite Link Block Diagram
(Wu, 1984: 27)

The major components in a SATCOM link are the earth station and the satellite. A SATCOM link is usually considered to be an uplink (transmitting earth station to satellite) and a downlink (satellite to receiving earth station).

Link analysis is a key method of evaluating SATCOM system performance and determining the technical feasibility of a the SATCOM system under study. The SATCOM system may be a simple point-to-point link, or have multiple users and include intersatellite links. The link budget looks at each of the major components in the system, totaling the effect of the components upon the system. For each component, the evaluation

may be as detailed or as coarse as the designer wishes. Thus the link budget is flexible enough to be used from the initial planning stages to the final detailed design stage.

A single channel link's performance is limited by downlink power, uplink power, satellite or earth station noise levels, and bandwidth. One of these items usually dominates. Most often it is the downlink signal-to-noise power ratio or channel bandwidth (Spilker, 1977: 170-171). The elements affecting channel performance are antennae, modulators/demodulators (modems), coders/decoders (codecs), transmitter and receiver filters, earth station high power amplifier (HPA), and satellite travelling wave tube amplifier (TWTA) (Wu, 1984: 28). The link budget allows the system planner to evaluate each of these elements and to determine their effect upon the above items which limit the channel's performance.

Link analysis allows the system planner to estimate system performance and allows him to evaluate tradeoffs between system parameters. Sklar points out that the link budget is useful in many areas of system design. One area is as a basis for optimal design search (Sklar, 1979: 1). Hence, the link budget may serve as a system of relationships to which other techniques can be applied to determine "optimal" solutions.

Communication systems are typically represented by block diagrams. Each block indicates a processing function which is generally implemented to improve system performance. However coupled with each improvement there is also a degradation, usually in the form of additional noise. For the preliminary development of the link budget, an additive white Gaussian noise (AWGN) channel is assumed. An AWGN channel is one which

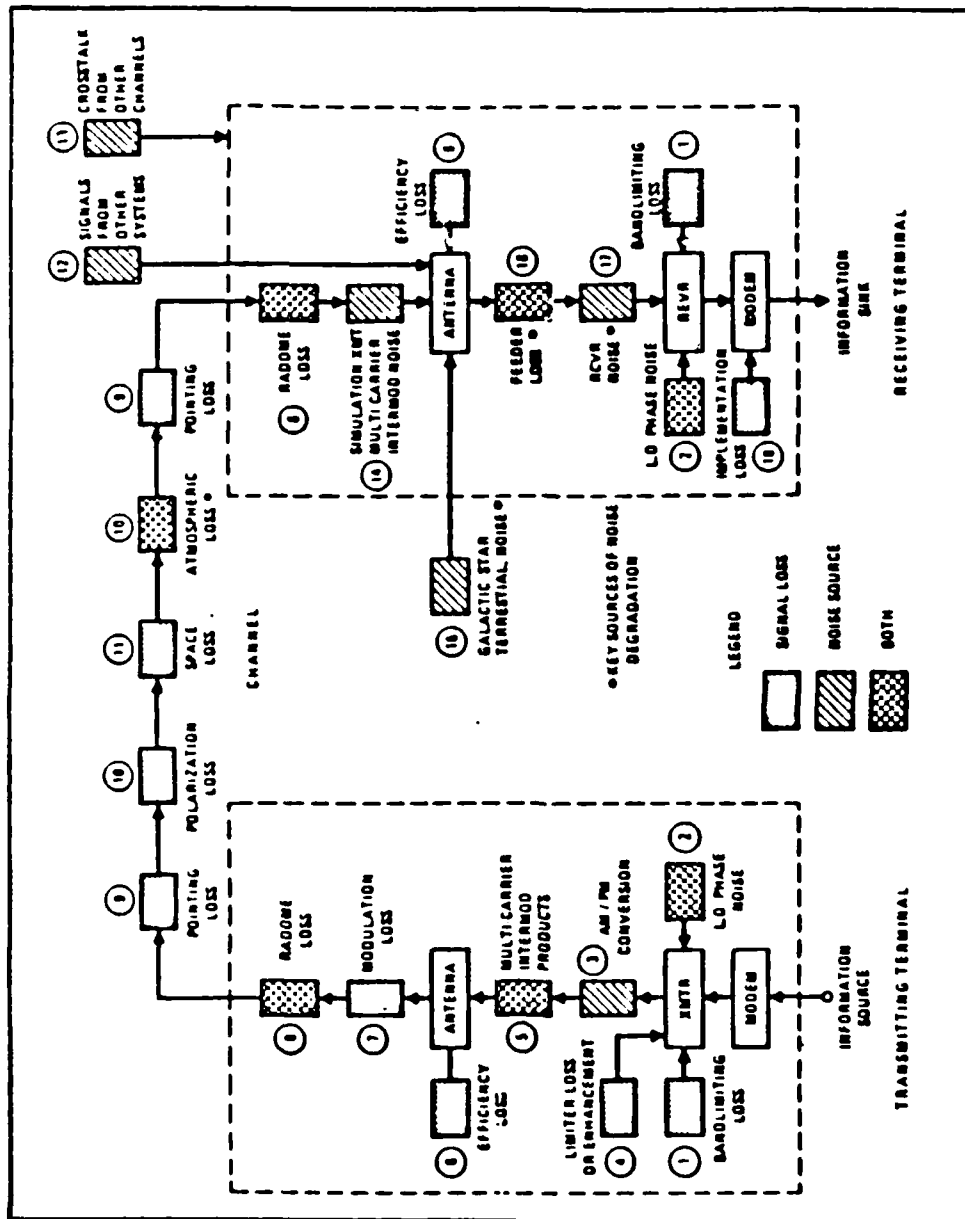

Figure 4-2. Typical Noise and Attenuation Sources (SKlar, 1979: 2)

has a flat noise power spectrum across all frequencies. For an AWGN channel the signal is degraded in two ways. There is attenuation of the desired signal and there is an increase of unwanted waveform power. These degradations are respectively called loss and noise (Sklar, 1979: 2).

"The communications system link budget is a balance sheet of gains and losses (Sklar, 1979: 1)." Figure 4-2 shows the many sources of noise and attenuation in a satellite link. The analysis of the gains and losses can be as detailed as desired, or may be made less precise by lumping gains/losses together and looking at the dominant contributions. It is this capability which makes the link budget a fundamental tool in satellite design. Free space loss, the attenuation of signal strength as it propagates, is the largest loss experienced in a SATCOM system. Noise introduced by the receiver's antenna, feeder line, and amplifier are the main sources of noise degradation (Sklar, 1979: 3). The transmitter power and antenna gains are the major contributors to desired signal strength. For this reason, the link budget contains four main components: the transmitter's parameters, receiver's parameters, propagation losses, and other losses. These components will be developed in the following paragraphs.

The signal power received by a distant station from a transmitter using an omni-directional antenna is given by

$$P_r = P_t A_{eR} / 4\pi d^2 \quad (1)$$

where P_r is the received power, P_t is the transmitted power, A_{eR} is the

effective receive antenna area, and d is the distance between the transmitter and the receiver. The gain, G , of an antenna concentrates the power in a particular direction. Gain is related to effective antenna area, A_e , by

$$G = 4\pi A_e / \lambda^2 \quad (2)$$

The carrier wavelength, λ , is the inverse of the carrier frequency (SKlar, 1979: 4). Gain can also be expressed in terms of antenna aperture area, A (the physical area of the antenna), by the antenna efficiency, η

$$G = 4\pi A \eta / \lambda^2 \quad (3)$$

$$= \eta (\pi D / \lambda)^2 \quad (4)$$

As noted in Eq (4) the antenna diameter, D , is proportional to the gain (Wu, 1984: 26).

Combining Eq (1) with the relationships for gain, the received signal power can be expressed in terms of effective antenna area, antenna gains, or antenna diameter. Using the gains of the transmit and receive antennae, the received power is

$$P_r = P_t G_t G_r \lambda^2 / (4\pi d)^2 \quad (5)$$

One of the key parameters which characterizes communication system performance is the ratio of received carrier power to the total noise

power. The carrier-to-noise ratio (CNR) is defined as

$$\text{CNR} = P_r/P_n \quad (6)$$

where P_n is the noise of the receiver (Gagliardi, 1984: 104). AWGN comes from cosmic, atmospheric, rain, and internal receiving system noises. The effect of all these noise sources can be summed and expressed as an equivalent thermal noise temperature, T_e (Wu, 1984: 26-27). The thermal noise power is given by

$$P_n = kT_e B \quad (7)$$

In Eq (7), k is Boltzmann's constant and B is the radio frequency (rf) bandwidth of the receiving system. The equivalent noise temperature is the summation of the receiver temperature, the feeder line temperature, and the antenna temperature (Sklar, 1979: 5).

Substituting Eqs (5) and (6) in Eq (7) yields

$$\text{CNR} = P_t G_t G_r \lambda^2 L / (4\pi d)^2 kT_e B \quad (8)$$

L has been included to represent any degradation factors not specifically addressed. The rf link power parameters are isolated by multiplying both sides of Eq (8) by the receiver bandwidth to normalize the bandwidth dependence (Gagliardi, 1984: 104). This new ratio is called the carrier-to-noise density

$$(C/N_0) = [P_t G_t][G_r/T_e][\lambda^2/4\pi^2][L/k] \quad (9)$$

Eq (9) is the basic relationship used in link budget analysis. The factorization has grouped transmitter parameters in the first bracket, receiver parameters in the second, propagation parameters in the third, and other parameters in the last bracket. Thus the contribution of each of the major system components is separate and identifiable (Gagliardi, 1984: 104-105; Feher, 1983: 41).

The transmitter parameters are normally referred to as the effective isotropic radiated power (EIRP)

$$\text{EIRP} = P_t G_t \quad (10)$$

This is considered to be the transmitter's figure of merit. The receiver's figure of merit is the ratio G_r/T . Care must be used with these figures of merit as satellite EIRP has an implied coverage and G_r/T has an implied frequency (Pritchard, 1979: 5). Free space loss is given by

$$\text{FSL} = (4\pi d/\lambda)^2 \quad (11)$$

This loss is always present and depends solely upon the frequency and the distance (Gagliardi, 1984: 84). Using EIRP and FSL, Eq (9) can be stated in terms of decibels as

$$\begin{aligned}
(C/N_0) \text{ dB-Hz} &= 10 \log \text{EIRP dBw} - 20 \log \text{FSL dB} \\
&+ 10 \log G_r/T_e \text{ dB/}^\circ\text{K} - 10 \log L \text{ dB} \\
&- 10 \log k \text{ dBw/}^\circ\text{K-Hz} \quad (12)
\end{aligned}$$

The critical parameter in designing a SATCOM system is the received carrier-to-noise density, C/N_0 . The required minimum C/N_0 is usually established. The difference between the required C/N_0 and the available C/N_0 is called the margin. Typically link margin is 4 dB for C-band, 6 dB for X-band, and larger for K-band (Spilker, 1977: 174-176). Margin is a means of compensating for variations in the losses experienced over the link. The most serious of these is rainfall attenuation. Raindrops scatter and absorb the energy, the effect becoming more severe as wavelength approaches the size of the droplet. Satellite links operating at X-band or above are severely affected by rainfall (Gagliardi, 1984: 96).

In the digital case, C/N_0 can be related to the received signal-to-noise per bit (E_b/N_0), and hence to the bit error rate (BER). This relationship is

$$(C/N_0) = (E_b/N_0)R_b \quad (13)$$

where R_b is the bit rate (Sklar, 1979: 6). The selection of modulation, coding, and access type determines the E_b/N_0 necessary to achieve a specified BER.

The inclusion of the margin, M , in Eq (12) provides the basic link budget. This basic equation is given for the analogue and digital cases

below

$$\begin{aligned} (C/N_0)_{\text{required}} \text{ dB-Hz} &= 10 \log \text{EIRP dBw} - 20 \log \text{FSL dB} \\ &+ 10 \log G_r/T_e \text{ dB/}^\circ\text{K} - 10 \log L \text{ dB} \\ &- 10 \log k \text{ dBw/}^\circ\text{K-Hz} + 10 \log M \text{ dB} \end{aligned} \quad (14)$$

$$\begin{aligned} (E_b/N_0)_{\text{required}} \text{ dB} &= 10 \log \text{EIRP dBw} - 20 \log \text{FSL dB} \\ &+ 10 \log G_r/T_e \text{ dB/}^\circ\text{K} - 10 \log L \text{ dB} \\ &- 10 \log k \text{ dBw/}^\circ\text{K-Hz} - 10 \log R_b \text{ dB-Hz} \\ &+ 10 \log M \text{ dB} \end{aligned} \quad (15)$$

Multiple Signals

The basic link budget assumes a single user. Two other factors affect the received C/N_0 when there are multiple users of the system. These are intermodulation effects arising from the use of nonlinear devices, such as HPAs and TWAs, and interference from the other signals. Intermodulation noise and interference will be discussed in the following paragraphs.

When a number of carriers at different frequencies are present in a nonlinear device, intermodulation noise is generated. This intermodulation depends upon signal strength, the degree of nonlinearity, and the number of carriers (Wu, 1984: 14). In the single carrier case, the nonlinear device is operated near saturation to obtain maximum gain. When multiple carriers are transmitted, the nonlinear device is operated below saturation to reduce intermodulation noise. Backoff refers to the point below saturation at which the device is operating. Input backoff,

$(BO)_{in}$, is the level of the input signal relative to the single-carrier saturation point. The output power level relative to the saturation output is called the output backoff, $(BO)_{out}$ (Wu, 1984: 31). Input and output backoff are related by the characteristic curve of the device. Intermodulation noise will be discussed later in the section on frequency division multiple access.

As satellite communication has developed, interference from adjacent satellites and terrestrial microwave has also increased. Interference is now becoming a limiting factor in SATCOM planning. The additive Gaussian channel model is overly simplified, hence these sources of interference must be considered when designing SATCOM systems (Wu, 1984: 10). Many of the channel impairments can be calculated using specific computer programs and "a general purpose link calculation program for system optimization seems desirable (Wu, 1984: 25)."

The results of the uplink, downlink, intermodulation, and interference can be combined to give an end-to-end carrier-to-noise density ratio. In general, the total carrier-to-noise ratio is of the form

$$C_T/N_T = [(C_1/N_1)^{-1} + (C_2/N_2)^{-1} + \dots + (C_n/N_n)^{-1}]^{-1} \quad (16)$$

Carrier-to-interference and carrier-to-intermodulation terms can also be included in the above equation.

There are many tradeoffs which can be evaluated with the link budget. In each of the main contributors to the link budget, one parameter can be traded for the other. For example, once a realistic

estimate is obtained, transmitter power can be traded for antenna gain as long as the EIRP remains the same. Similarly receiver temperature can be traded for receive antenna gain. Less obvious effects can also be evaluated. By manipulating the link budget and looking at the antenna coverage area, a frequency independent relation which gives the minimum antenna size for given transmit powers and data rates can be found (Pearce, 1985).

Multiple Access

We have that category of problem unique to satellite communication that arises from the necessity of and desirability of exploiting the geometric availability of a geostationary satellite to any point over almost a third of the earth's surface. Before this convenience can be realized, it is necessary to choose a system of multiple access. In a very real sense we can call this the problem of satellite communications (Pritchard, 1979: 5).

In this section I will discuss the topic of multiple access, how to allow many earth stations to make use of a communication satellite.

I begin by discussing the three main methods of multiple access. These methods are frequency, time, and code division multiple access. A brief outline of the methods of assigning each access to the satellite resources is then given. The section closes with a discussion of each of the access techniques in terms of it's affect on the link budget.

The purpose of multiple access techniques is to divide the satellite resources (power and bandwidth) and to allocate these divisions among the users (Jabbari, 1984: 1556). The time and frequency dimensions are normally used as the means to divide the resources. The major forms of multiple access today are frequency division multiple access

(FDMA), time division multiple access (TDMA), and code division multiple access (CDMA).

FDMA divides the bandwidth into separate non-overlapping sub-channels. Each user has a separate portion of the bandwidth in which to transmit. This technique is easy to implement and does not require user coordination. However, FDMA does not efficiently utilize the satellite transponder for bursty traffic (Retnadhas, 1980: 16-17).

TDMA divides the resources along the time dimension. Each user has a separate non-overlapping time slot in which to transmit data. TDMA is more efficient in its utilization of the transponder resources and allows greater capacity. TDMA is more complex to implement, requiring precise timing and synchronization between all earth stations. (Retnadhas, 1980: 16-17).

CDMA utilizes the entire time-frequency plane for each transmission. A unique pseudo-random sequence is used to modulate the carrier (spreading it over the entire bandwidth) or to change the frequency of the carrier (hopping it to discrete points in the frequency bandwidth) (Gagliardi, 1984: 267). CDMA offers the advantages of low probability of intercept and anti-jam capability. The disadvantages of CDMA are the complexity required for synchronization and demodulation, and the fact that CDMA does not make efficient use of the satellite transponder.

Once the resources have been divided, FDMA and TDMA must allocate the frequency or time slots to the users. There are three methods: random assignment, fixed assignment, and demand assignment. In random assignment, the station transmits a block of information in a slot selected at random. If two stations select the same slot then the blocks must

be retransmitted in another slot selected at random. In the fixed assignment method, each earth station is assigned a dedicated slot. The station transmits in the slot whenever it has traffic, however the slot is idle at other times. Slots are dynamically allocated in demand assignment. When an earth station has traffic to send, it requests a slot from a central controller. When the traffic has been passed, the slot reverts to a pool of slots waiting to be assigned by the controller.

Frequency Division Multiple Access

In the initial development of the end-to-end link budget, the transponder was treated as a linear device. In this section I will develop the effects due to the non-linear devices used in the satellite. A bandpass limiter (BPL) is used as an amplitude and power control device. The BPL prevents amplitude swings and sets power levels for the final amplifier stage. The reason for this is that TWTA's are intended for constant amplitude signals. Input amplitude variation result in phase variations and interference.

Unlike the ideal frequency translation model assumed earlier, the BPL alters the CNR. This can be represented as a ratio of the output CNR of the BPL (CNR_{BPL}) to the input (CNR_i), giving

$$\Gamma = CNR_{BPL}/CNR_i \quad (17)$$

This modification of the input carrier and noise powers (P_{CO} and P_{NO} respectively) can be represented as signal and noise suppression factors

$$P_{co} = \alpha_s^2 P_c \quad (18)$$

$$P_{no} = \alpha_n^2 (N_0 B_{RF}) \quad (19)$$

where α_s^2 = signal suppression factor

α_n^2 = noise suppression factor

P_c = input carrier power

$N_0 B_{RF}$ = input noise power

Since $DNR_{BPL} = P_{co}/P_{no}$ we find the suppression factor ratio

$$\Gamma = \alpha_s^2 / \alpha_n^2 \quad (20)$$

(Gagliardi, 1984: 163-166)

In applying this to a FDMA system, assume K uplink carriers of equal bandwidth, B, and total carrier power

$$P_u = \sum P_{ui} + KP_{un} \quad i = 1 \text{ to } K \quad (21)$$

The input power to the transponder TWTA is controlled with a BPL, thus allowing adjustment of the input backoff. If $\max P_T(K)$ is the TWTA'S maximum output power with K carriers, then the output power is

$$P_T = \max P_T(K) / (BO)_0 \quad (22)$$

The received downlink power, for the i^{th} carrier is

$$P_{di} = P_T(P_{ui}/P_U)\alpha_s^2 L \quad (23)$$

where L is the downlink loss factor which represents all gains and losses from the TWTA output to the receiver input. The total received noise power is

$$\text{Received Noise Power} = N_{odB} + P_T(P_{un}/P_U)\alpha_n^2 L + N_{oIBL} + C_i P_{di} \quad (24)$$

The first component of the RHS of Eq (24) is the noise contribution from the downlink. The other components are the contributions of the uplink, intermodulation, and crosstalk respectively. The downlink receiver CNR for a particular carrier is the ratio of Eq (23) to Eq (24) and it can be shown to equal

$$\langle \text{CNR}_d \rangle^{-1} = \langle \Gamma \text{CNR}_u \rangle^{-1} + \langle \text{CNR}_r \rangle^{-1} + \langle \text{CNR}_I \rangle^{-1} + \langle \text{CNR}_C \rangle^{-1} \quad (25)$$

where CNR_u = Uplink carrier CNR at the satellite limiter input

CNR_r = Downlink carrier CNR due to available satellite power

CNR_I = Carrier-to-intermodulation ratio

CNR_C = Carrier-to-crosstalk ratio

Γ = Nonlinear suppression of the satellite limiter

To determine digital performance, the bandwidth, B, in Eq (24) is replaced by T_b^{-1} and the ratio of Eq (23) to Eq (24) is evaluated to get

$$E_b/N_o = \text{CNR}_d \quad \text{with } B = 1/T_b \quad (26)$$

These equations can be manipulated to find the required amplifier power and the number of carriers which can be supported. In the first case the ratio of Eq (23) to Eq (24) is solved for P_T , the required carrier power for carrier i . This is evaluated for all i and the maximum P_T is the required operating point. If $B = B_{RF}$ is substituted in the ratio of Eq (23) to Eq (24) and the ratio is solved for K , the number of carriers which can be supported is determined. The minimum of the bandwidth or available satellite power is selected as K (Gagliardi, 1984: 212-215).

Time Division Multiple Access

The TDMA format is shown in Figure 4-3. The frame is repeated and each user transmits a burst of data in it's allocated slot. As shown each slot has an overhead called the preamble. The preamble consists of a guard time to allow for timing errors, a carrier and bit time recovery sequence, and a unique word to set word markers for the remainder of the transmission. The frame time is determined by the number of bits per slot, b , which the digital sources produce while operating at R_C bits/sec, hence

$$T_f = b/R_C \text{ seconds} \quad (27)$$

The preamble efficiency, η_p , is defined as the number of preamble symbols divided by the total number of symbols per slot. For P preamble

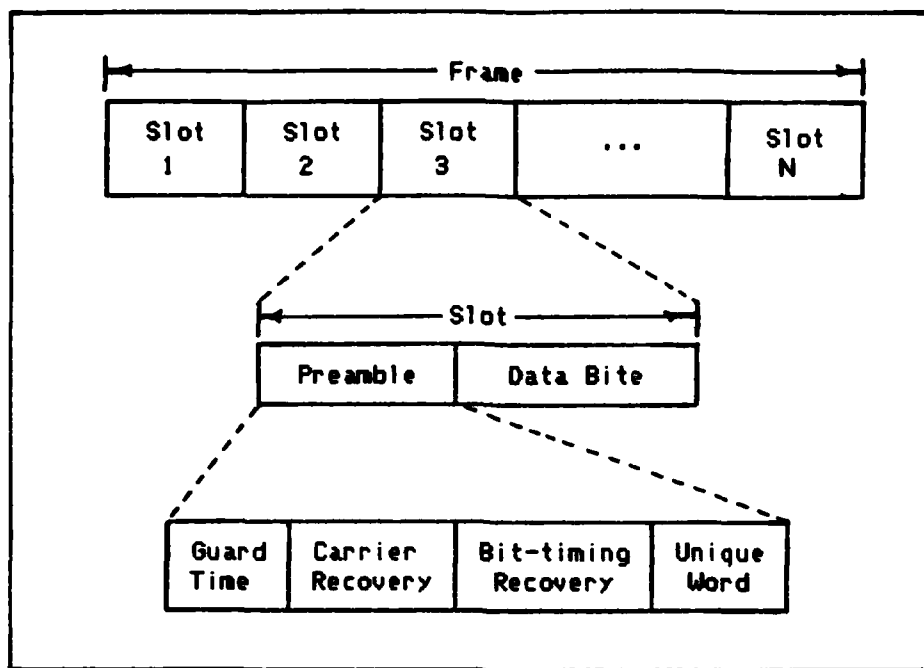

Figure 4-3. TDMA Frame Format
(Gagliardi, 1984: 232)

bits and D data bits

$$D = [(1 - \eta_p) / \eta_p] P \quad (28)$$

It should be noted that b represents the number of bits from one source to be multiplexed into a slot, while D represents the total number of bits arising from the multiplexing.

If the satellite power and bandwidth allow a transmission rate of R_{RF} , the slot times must allow for $D + P$ bits, hence the slot time τ is

$$\tau = (D + P) / R_{RF} \quad (29)$$

and the number of slots, Q , is

$$\begin{aligned} Q &= T_f/\tau \\ &= bR_{RF}/[R_c(D + P)] \end{aligned} \quad (30)$$

The total number of sources operating at b bits/burst and rate R_c bps is (Gagliardi, 1984: 230-234)

$$\begin{aligned} K &= QP/b \\ &= D/(R_c\tau) \\ &= [R_{RF} - (P/\tau)]/R_c \end{aligned} \quad (31)$$

The transponder for the TDMA case is modeled as a hard limiter. Thus the downlink CNR is

$$CNR_{RF} = P_T \alpha_s^2 / (\alpha_n^2 P_{TL} + N_{od} B_{RF}) \quad (32)$$

where $\alpha_s^2 = \Gamma CNR_U / (1 + \Gamma CNR_U) \quad (33)$

and $\alpha_n^2 = 1 / (1 + \Gamma CNR_U) \quad (34)$

For the digital channel this can be written as

$$CNR_{RF} = [(E_b/N_0)/B_{RF} T_b] S_T \quad (35)$$

where $E_b/N_0 = P_T L T_b / N_{od}$ (36)

$$S_T = \Gamma \text{CNR}_U / [1 + \Gamma \text{CNR}_U + (P_T L / N_{od} B_{RF})] \quad (37)$$

(Gagliardi, 1984: 239-240).

The bit rate which a satellite can support is determined by the available satellite bandwidth and the ground station received CNR. In the bandwidth limit,

$$R_{RF} = \eta_T B_{RF} \quad (38)$$

where η_T is the satellite throughput, which depends upon the modulation technique selected. The CNR limit is given by

$$R_{RF} = P_T L S_T / \gamma N_{od} \quad (39)$$

where γ is the value of E_b/N_0 required by the decoder to achieve the desired probability of error. The allowable bit rate is the lesser of the bandwidth or CNR limit (Gagliardi, 1984: 250-251).

Code Division Multiple Access

In CDMA each link occupies the entire bandwidth. Coding sequences are chosen to make the signal appear as white noise or prevent mutual interference. Mutual interference does occur because the pseudo-random sequences used to create the spread spectrum are not orthogonal. This interference places a limit on system capacity.

Thus the total noise on the uplink is a key factor in system

performance. The total noise for the i^{th} carrier is the result of thermal noise and interference from all other carriers. For K users, this interference noise is the sum of received power from all other carriers

$$N_{\text{Int}} = \sum P_{uj} \quad j = 1 \text{ to } K, j \neq i \quad (40)$$

Thus the interference CNR is

$$\text{CNR}_{\text{Int}} = P_{ui} / N_{\text{Int}} \quad (41)$$

and we find the overall receiver CNR to be (BPL transponder assumed)

$$(\text{CNR}_D)^{-1} = [(\text{CNR}_U^{-1} + \text{CNR}_{\text{Int}}^{-1})^{-1}]^{-1} + (\text{CNR}_P)^{-1} \quad (42)$$

In the case of equal uplink powers, $N_{\text{Int}} = (K-1)P_U$. As K increases this becomes approximately $N_{\text{Int}} = KP_U$ and in the limit

$$\text{CNR}_{\text{Int}} = 1/K \quad (43)$$

Link Analysis Parameters

Based upon the above discussions a summary of the elements of the link budget has been assembled in Appendix A. These elements form the kernel for the DSS. This summary is divided into the uplink, the downlink, and the total end-to-end portions. In addition a general information section has been included. The summary provides a worksheet for

calculating link budgets. A collection of the pertinent equations is located in Appendix B. These allow the link budget and its parameters to be evaluated.

V. ROMC Analysis

Introduction

This chapter deals with the systems analysis of the kernel DSS. It must be stressed that the kernel deals with determining technically feasible SATCOM systems alternatives which will serve as inputs to the DPMS in order to meet user requirements. Following a review of the representations, operations, memory aids, and control mechanisms approach (ROMC), each of these areas will be discussed as it pertains to the design of technically feasible SATCOM systems. The last section in the chapter deals with "hooks" for future development under the iterative design.

The ROMC approach looks at the design process from the user's viewpoint, attempting to capture what he sees, what he does, how he manipulates the SATCOM design, and what data he requires. Representations are conceptual presentations of the information used in the decision process. Representations provide a communications method to pass output to the DSS user and to obtain DSS user input. Operations allow the DSS user to manipulate the representations and the information they contain. Memory aids are the data bases, workspaces, and interconnections which are required for analysis of SATCOM system designs. Control mechanisms are the means by which the designer utilizes the representations, operations, and memory aids to facilitate his own personalized decision-making process.

Representations

There are seven representations which are required for the SATCOM design process. These representations are tables, block diagrams, graphs, maps, equations, statement language lists, and extraction language lists. Each of these representations will be discussed in the following paragraphs. The components of the representation are discussed and some examples are given.

Tables provide a means of displaying selected variables and their values, for example Table 5-1 illustrates a link power budget. Tables

Table 5-1. Sample Table of Link Power Budget
(Wu, 1984: 32)

Number of Frequency Reuse	6
Occupied Bandwidth (MHz)	60.0
Occupied Bandwidth (dB-Hz)	77.8
<i>Uplink</i>	
Saturation Flux Density (dBW.m ²)	-76.7
Satellite G/T (dB/K)	-2.9
Input Backoff (dB)	2.0
C/N Thermal Noise (dB)	32.2
C/I Frequency Reuse (dB)	20.5
C/I External System Interference (dB)	32.2
C/(N + I) Uplink (dB)	19.9
<i>Downlink</i>	
Saturation e.i.r.p. at Beam Edge (dBW)	30.0
Output Backoff (dB)	0.3
Path Loss (dB)	197.2
Earth Station G/T (dB/K)	40.7
C/N Thermal Noise (dB)	24.0
C/I Frequency Reuse (dB)	20.5
C/I External System Interference (dB)	32.2
C/(N + I) Downlink (dB)	19.7
Total C/(N + I) (dB)	16.3
Miscellaneous Loss (dB)*	1.1
Net Available C/(N + I) (dB)	15.2
Net Available E _s N _s (dB)	12.2

* Includes adjacent channel interference, dual path, and antenna pointing error.

also allow the comparison of alternatives if several values are shown for different trade-offs. Tables may be used to present satellite/earth station data for existing systems, information on data rates for various information sources, or the constituents and results of a link budget.

Block diagrams provide an effective method to show the various components of the system. These diagrams can be composite in nature, showing only the main elements of the system, or be very detailed. Figure 5-1 shows a block diagram of a satellite transponder. The blocks can be entered as points and connecting lines labeled to produce a chart. Such a representation can show factors affecting the link budget

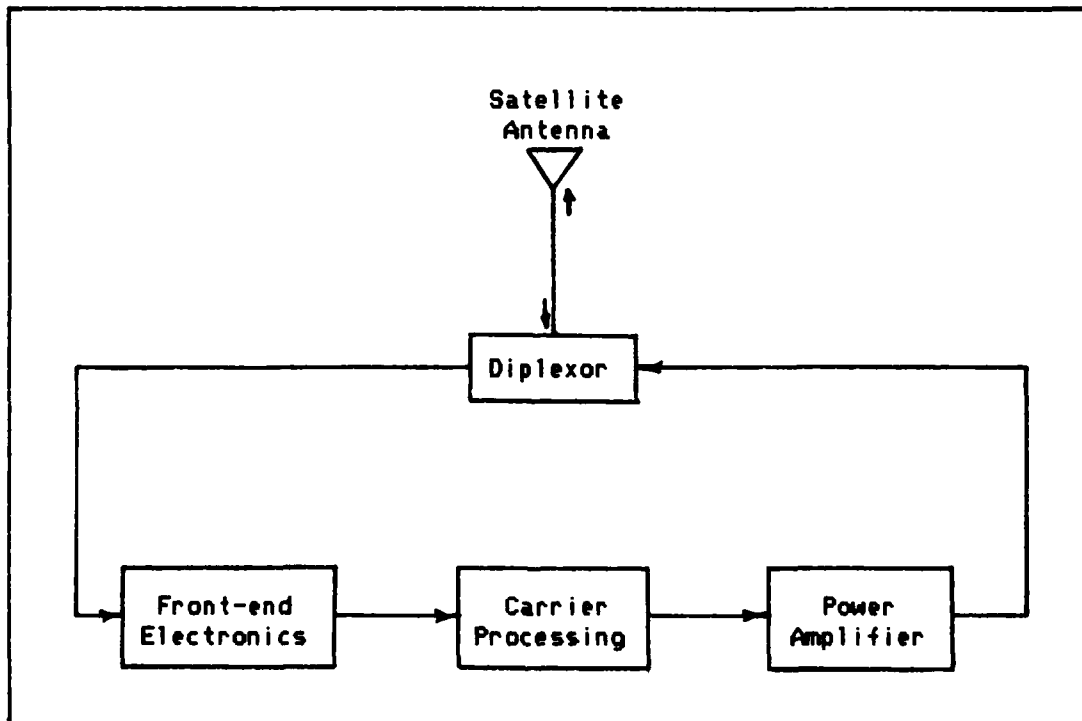

Figure 5-1. Sample Block Diagram of Satellite Transponder (Gagliardi, 1984: 135)

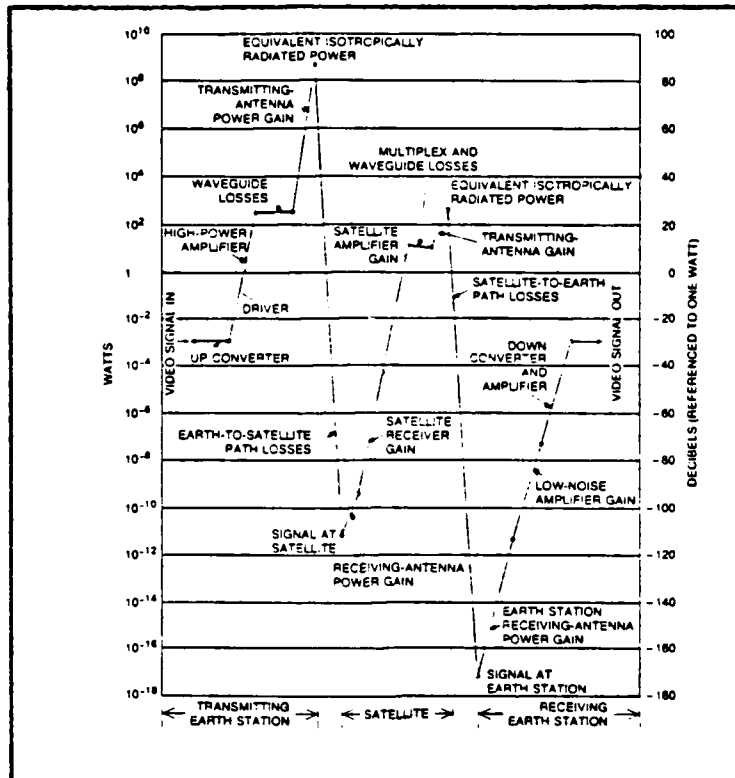

Figure 5-2. Sample Link Budget Chart
(Wu, 1984: 29)

or the values of the CNR at various points throughout the system. An example of this is given in Figure 5-2, a link budget chart.

Graphs provide a method to visualize the effect of one variable upon another. The 'curves' on a graph can be used to select operating points, see the trade-offs involved, or to determine optimum points. An example is given in Figure 5-3, a graph of typical power amplifier operating curves. Maps can provide a sense of geographic separation between earth stations and illustrate the earth coverage of a satellite.

Equations give the relationships between various variables. They can be combined and manipulated to isolate selected variables which are

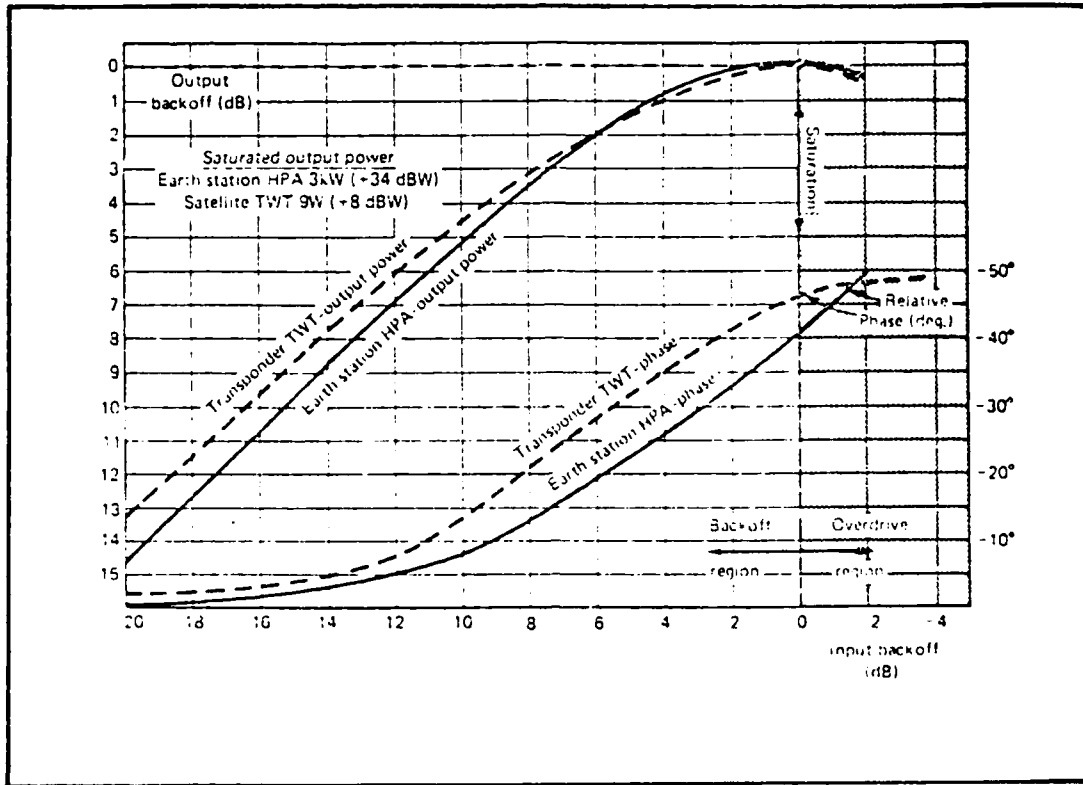

Figure 5-3. Sample Graph Representation of Operating Curves
(Feher, 1983: 32)

under study. Any of the equations developed in Chapter 4 illustrate this form of representation.

The report language list and extraction language list are lists of commands which allow the DSS user to interface with the DSS. The report language list is a representation of the methods the DSS user has to prepare reports and insert comments to document the decision process and provide a record of his actions. The extraction language list is a representation of the means the DSS user has available to extract data from the data base. Such lists provide data manipulation and processing aids.

Operations

The operations include a set of actions for each representation. There are some operations, such as print, which may be common to one or more representations. A single operation may suffice, however its listing under each representation indicates a group of defaults applicable to that representation.

Table operations allow the designer to create a display of the parameters he is using in the link analysis. Specific values can be entered and adjusted. Areas of over or under design can be identified as well as the limiting factors in the link. The following operations apply to the table representations:

1. Select table variables. This may be done on an individual or default manner. The table of link budget parameters in Appendix A is an example of a default table.
2. Amend table entries. Variables could be added, deleted, aggregated or moved to suit the DSS user's requirements. It would also allow data in the table to be added, deleted, or changed.
3. Calculate table entries. This allows the completion of data columns/rows from other data already in the table. For example, with the earth station and satellite locations entered, the slant range could be calculated.
4. List standard (default) tables. This operation provides the DSS user a listing of the default tables and/or definitions of variables in the tables.
5. Print table.
6. Display table and data values. This would display on the screen the selected table and values of the data which have been generated to that point.
7. Name table. This would generate a label for the particular table being worked on and allow it to be displayed.
8. Save table. A table may be stored for future use, or as a means to save intermediate steps.

Block diagram operations allow the designer to diagrammatically depict signal flow in the system or the order of components. In the form of a chart, these operations permit the designer to pictorially depict the effects of system components. Block diagram operations consist of the following activities:

1. Name diagram.
2. Create blocks. This allows blocks, labels, and other pertinent data to be put on a diagram.
3. Order blocks. This specifies the sequence of blocks in the diagram feedback and interconnections.
4. Display diagram.
5. Amend diagram.
6. Save diagram.
7. Print diagram.
8. Label diagram. This allow additional comments to be added to the basic block diagram.

Interrelationships between parameters can be depicted using the graph operations. In simple cases, graphs can allow the selection of optimum parameter values. The set of operations for graphs should consist of the following:

1. Label axes. This allows the selection of one to three dimensions and provides the capability to scale the axes.
2. Name graph.
3. Relationship. This indicates a mathematical function linking the variables. It would also allow the generation of a family of curves for given values of a particular parameter. For example the G/T of a satellite could be plotted versus the CNR for various values of earth station EIRP.
4. Data. Discrete values could be entered using a data operation.
5. Plot. This would connect points or show curves on the graph.

6. Combine. The combine operation would allow multiple curves to be drawn on one graph. It could also be used to plot the effects of two curves to give a resultant third curve. For example, the carrier-to-intermodulation ratio curve versus input back off could be shown on the same graph as the operating characteristic curve for the TWT. These curves could be combined in one curve which would show the resultant CNR out of the TWT based on the non-linear characteristic and intermodulation.

7. Print graphs.

Map operations permit the designer to visualize geographical relationships. The creation of maps showing standard coverages could be used to determine initial feasibility. For example, earth coverage maps could be used to eliminate a particular satellite if one of the terrestrial stations is below the radio horizon. The map operations consist of the following:

1. Display a map.
2. Modify locations.
3. Plot curves. This allows given levels of coverage to be displayed for various satellite antenna patterns and focal points.
4. Expand map. This allows closer examination of an area or centered on a given location.
5. Save Maps.
6. Print maps.

Equation operations are the main method of employing the analytic tool. They establish the interrelationships and allow the calculation of values required for the link analysis. The following set of activities for equation operations are necessary:

1. Glossary. A glossary of variables, their meanings and synonyms would allow identification and cross-reference.
2. List. This permits the viewing of all equations, or could be constrained to those containing specified parameters.
3. Solve. This is an operation that would rearrange the equation

to give the specified parameter in terms of all others.

4. Insert. This substitutes for a specified parameter in terms of a related group of parameters.
5. Calculate. The value of an equation for a given set of data is determined.
6. Print equations.
7. Insert/delete. These operations allow the list of equations to be modified.

As with any design process, documentation is a critical element.

Report language operations provide the means for the designer to document the design. This provides a history and leads to the implementation phase, which requires the submission of a principal document in the DPMS. The report language operations would permit the DSS user to:

1. Generate reports and comments.
2. Edit reports and comments.
3. Save reports and comments.
4. Modify reports and comments (eg. copy, delete, rename).
5. Print statements, reports, and comments.
6. Use resident functions of the computer (logical and arithmetic).

The extraction language operations permit the DSS user to manipulate the data bases. The operations act as an interface between the designer and the internal and external data bases. The SATCOM designer uses these operations to easily create data bases with suitable content and format for the design at hand. The necessary extraction language operations are:

1. Defining new records, including their format and parameters.
2. Selecting data using some desired criterion.

3. Modifying data records.
4. Aggregating data.
5. Extract data from other data bases to create a data base for a particular problem.

An example design problem is worked in Appendix C. The example indicates how some of the representations and operations would be used.

Memory Aids

The following memory aids are required in the DSS: work spaces, libraries, links, checklists, profiles, and data bases (Sprague and Carlson, 1982: 104). Workspaces provide the area in which representations are manipulated by the operations. The intermediate steps are preserved as an audit trail or to allow the user to return to an intermediate point and analyze an alternative solution. Libraries allow workspaces to be saved for later use. Data may be passed between workspaces via the links. For example, two relations could be developed in an equation workspace. These relations are transferred to a graph workspace, where each relation is plotted. The two plots are combined and a desired point is selected and "linked" back to the equation workspace. Information can be linked by two proposed methods. The first method allows the designer to identify information in one workspace or representation and copy it to another. The second method would be to update the data base, which then updates that parameter in all representations.

Checklists provide a method to remind the DSS user of required operations etc. Checklists also serve as a means of identifying repetitive sequences of operations which may be aggregated using a control mechanism. Two initial checklists are required. The first deals

with user requirements. Sample elements include:

- traffic volumes and types
- data rates
- interconnections within the network
- OPSEC/COMSEC requirements
- availability and redundancy
- interoperability with existing systems and allied forces
- maintenance philosophy
- operational threat assessment

The second ensures that the designer has considered all pertinent factors. Sample elements include:

- availability
- link margin
- transponder utilization
- equipment commonality
- jam/intercept protection

Profiles would store default values and provide a starting point for work. Profiles could be combined with checklists to determine minimum information requirements from the customer (SATCOM user). There are four data bases required: technical data, satellite/earth station data, traffic data, and existing SATCOM systems.

The technical data base would contain data such as bit error rate versus bit energy to noise ratio, baseband bandwidths, digital data rates, coding gains, etc. This data base would be internal as it would be frequently used and the data is constant. The internal data base could be supplemented by reference books and articles, which would cover

the newer and more novel data. Initially this data could be off-line in the form of texts or reference manuals.

A summary of satellite/earth station data would also be held in an internal data base. Satellites which provide coverage to Canada and existing earth station characteristics (both commercial and military) would be included. A set of "typical" satellite and earth station characteristics is also necessary. These latter characteristics would provide default values as needed.

Traffic data is necessary to determine link capacities and data rates. This data normally resides in external data bases, maintained by the user. The ability to extract representative sets or the provision of such sets by the user is needed. Similarly, data on existing military SATCOM systems would be maintained by the user, requiring an extraction capability for the DSS.

Control Mechanisms

Control mechanisms are to include menus, command structure, function keys, training manuals and on-line tutorials, and a method to combine operations. The menus, command structure, and function keys provide a layered approach to the representations and operations as well as standard system functions (editor, operating system). The menus would be of two forms, detailed sequential menus and an abbreviated menu. In both cases "help" would be available with complete explanations. Commands would allow the DSS user to use the DSS from the keyboard. The commands would consist of short words or abbreviations. The final step is the function key which would allow the DSS user to imple-

ment an operation with one key stroke. These levels would allow personalized usage of the DSS. The new user or the one who did not want to memorize the commands or function keys could use the menus, moving to the abbreviated menu as familiarity increased. Command and function keys allow the experienced user to use the system with speed, not having to step through menus.

The training manuals and on-line tutorials would be used to familiarize users with operation of the DSS and the underlying technical theory of the link budget and other models. These tutorials could also be used to train the users in better decision techniques, for example, exposing the user to linear programming to find optimum points rather than heuristic methods.

The method to combine operations allows the DSS user to tailor the DSS to his personal decision style. It would allow him to change and establish defaults and create his own procedures. This could mean standard representations he prefers, his own checklists, screen format, etc. It would also allow him to create "macro" commands and function keys.

"Hook" Book

The link budget provides a kernel system to determine the technical feasibility of a SATCOM system. There are obviously several other modules which must be added to provide a "complete" DSS. This section discusses some of the additions which have been identified, and for which "hooks" must be inserted in the kernel system. I view these hooks as being in five areas: interfacing with the DPMS, cost information,

optimization techniques, deeper technical analysis, and hardware.

In the DPMS interface area, there are two hooks: one for an AHP package and one for Steward's design structure system. The AHP would provide a means of integrating the customer's desires into the design and evaluation process. AHP is already used by DND for evaluation of contractor's proposals. The use of AHP to determine customer-acceptance parameters and their weights would provide a means to bring the user into the design stage in a much more influential manner. It would also provide for the integration of the design and evaluation stages. Steward's design structure system allows the variables to be related to the customer's requirements and to see the effect of design trade-offs on the customers's requirements.

Cost is one of the major parameters in selecting new systems. For this reason, cost in terms of purchase costs and life cycle costs, must be added to the DSS at an early stage. The presence of this information allows cost-benefit type analyses for input to the DSP.

Optimization techniques would allow the selection of the best solution to design problems. The initial technique should be a simple linear programming. This could be followed by more complex techniques, such as those suggested by Wu. Optimization techniques can be combined with cost data to determine least cost systems, and determine optimum points where SATCOM becomes cost effective.

The addition of modules which allow deeper technical analysis should permit better determination of technical feasibility and permit the full exploration of trade-offs as the design progresses and becomes more detailed. For example, intermodulation was discussed under the

link budget. However, a means for evaluating intermodulation was not presented. Computer programs which evaluate intermodulation are available and should be added.

The final area is that of hardware. It has been implicitly assumed that the computer consists of a visual display terminal, a keyboard, and a basic printer. Additional hardware would allow for user preferences and for better output. Input could be improved and personalized by adding a mouse, light pen, etc. Output would be improved by a graphics printer and the ability to produce slides and vu-graphs from the screen. Graphics capabilities and increased memory are essential.

VI. Conclusions and Recommendations

Summary

My research began with a wide range of articles on DSS applications, management science techniques, communications engineering, and general readings on satellite systems. This literature review narrowed to the aspects of a DSS relevant to understanding the decision process and a search for a suitable analytical tool for SATCOM system design. At the same time the focus moved to developing a kernel to determine technically feasible alternatives. Two other issues were examined during the literature review. The first was the selection of a systems analysis and DSS design approach. Iterative design using Sprague and Carlson's representations, operations, memory aids, and control mechanisms (ROMC) was selected. The second issue dealt with management science/operations research techniques which were applicable to SATCOM system design. A number of techniques were found, including the AHP and the design structure system. Wu provided a summary of mathematical programming methods. He also points out there is often more interest in developing new technological approaches than in using operations research methods to optimize system performance (Wu, 1984: 439-506).

A model of the decision process was then developed. Against the background of the DPMS, the user involvement and iterative nature of engineering design were developed. At the same time the use of a technique such as the AHP was discussed as a means of determining customer-acceptance parameters and linking these through the SATCOM design pro-

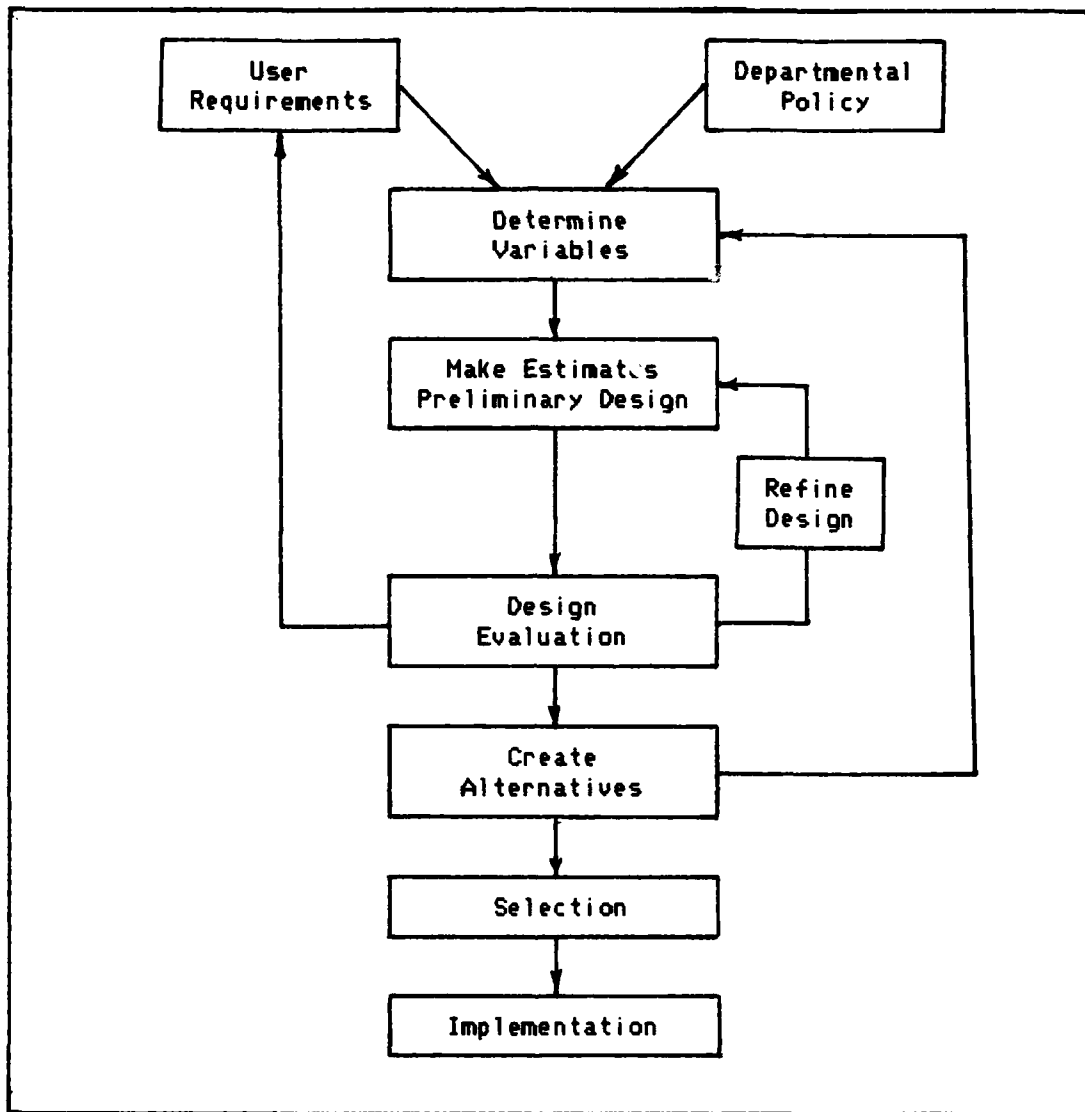
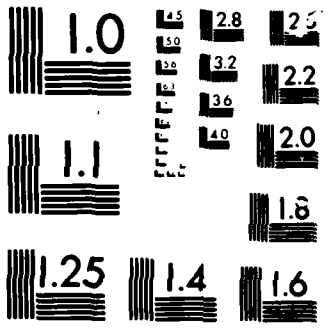

Figure 6-1. The SATCOM Decision Process

cess to the evaluation of alternatives. The model is presented in Figure 6-1. This model was discussed in terms of the aspects of a DSS pertinent to the analysis of the decision process.

This discussion found that the design of SATCOM systems was a semi-structured task at the management control level. The process takes



MICROCOPY

CHART

place in an environment which involves both independent and interdependent decisions. The design of SATCOM systems involves all levels of decision making. Identification of a requirement marks the beginning, of the intelligence phase. As the process continues, alternatives are designed and a choice is made. Implementation involves the preparation of the necessary document for the DPMS. The control portion of the process involves amending the document, beginning over, or entering the next phase of the DPMS. The five perspectives of decision making were all found to affect the decision. The result of this analysis was that the SATCOM design process could definitely be supported by a DSS.

Following the decision process, link analysis was developed as a means of determining the technical feasibility of a SATCOM system. The basic components involved in the analysis were presented as well as the figures of merit often associated with a SATCOM system. Confounding influences such as interference and intermodulation were then added. The unique SATCOM problem of multiple access provided additional variables for design consideration. This area also extended the single link to the case of limited resources and multiple users. A set of parameters for link analysis and a set of applicable equations summarized this portion of the research.

Finally the research discussed the RDMC's necessary for the DSS. Six representations: graphs, maps, equations, block diagrams, statement language lists, and extraction language lists were discussed. Supporting operations were also developed. An emphasis was placed on providing a variety of operations so that the DSS user could personalize procedures to his own taste. The section also identified linkages to other

modules that should be added to the kernel during the process of iterative design.

Conclusions

A DSS is well suited to assist in the planning of Canadian MILSATCOM systems. It offers the potential to allow DCESR planners to translate user requirements into technically feasible SATCOM systems. Link analysis provides a common analytic technique to analyze the tradeoffs involved and to prepare the specifications for a technically feasible system. The link analysis parameters and equations in Appendices A and B provide the kernel for constructing the DSS model base.

The AHP is an important enhancement to the initial technical feasibility model base. It can serve as a means to link customer requirements to the design, evaluation, and selection of a SATCOM system. Other operations research techniques have a place in the model base of the DSS.

The data base required to support the DSS requires technical data, traffic data, data about current commercial and military systems, and Canadian Forces operational SATCOM system data. Traffic data and operational data will be extracted from other sources while the remaining data will be internal.

There are several links which can be developed as future modules to be added during iterative design. The cost and AHP modules are the most significant. Additional technical analysis and operations research methods are also needed as follow-on modules.

Recommendations

I recommend that a prototype DSS be developed using link analysis as the kernel. The link analysis parameters and equations contained in Appendices A and B are the basic elements that must be contained in the kernel. During this development a "hook" book must be maintained to identify additional capabilities to be developed during the iterative design process.

Cost and AHP are the two modules which should be studied and developed once the kernel is established. Cost modules would allow cost/benefit studies and provide input to the DPMS. AHP provides a means to determine the customer's requirements and the importance he attaches to them. These play an important part throughout the design and evaluation of a SATCOM system.

Link analysis can be developed further. Additional techniques for intermodulation, interference, crosstalk, etc. can be added to develop a single comprehensive model. The same applies to the area of operations research methods for use in SATCOM system design. Research in either area and combining them with the kernel would be worthwhile.

Appendix A: Proposed Table Representations
Link Budget

General Parameters

The general parameters provide the overview information necessary to begin the link analysis. Included are locations, frequencies, and performance requirements.

Earth Station Name
Latitude
Longitude
Satellite Name
Satellite Location
Uplink Frequency
Downlink Frequency
Slant Range
Required BER
Required Data Rate
Modulation
Required E_b/N_0
Availability

Uplink Parameters

The uplink parameters given below provide a starting set to the designer. He may add or delete as is required by the situation.

Transmitter

Power (saturation)
Circuit Losses
Backoff
Antenna Diameter
Effective Aperture
1/2 Pwr Beamwidth
Antenna Gain
EIRP

Losses

Free Space Loss
Atmospheric Losses
Pointing Loss
Other Losses

Satellite Receiver

Antenna Diameter
Effective Aperture
1/2 Pwr Beamwidth
Antenna Gain
Circuit Losses
Noise Figure
Noise Temperature
Antenna Temp
System Temperature
System G/T

Uplink Power Ratios

Boltzmann's Cnst
System Bandwidth
CNR Thermal
C/I Freq Reuse
C/I External Int
C/(N+I) Total Up
C/N₀ Up

Downlink Parameters

The effect of the downlink can be calculated using the representation below. Again, parameters can be added or deleted to suit the problem.

Satellite Transmit

Power (saturation)
Circuit Losses
Backoff
Antenna Diameter
Effective Aperture
1/2 Pwr Beamwidth
Antenna Gain
Xmtd Signal Power
Xmtd N + I
EIRP

Losses

Free Space Loss
Atmospheric Losses
Pointing Loss
Other Losses

Earth Stn Receiver

Antenna Diameter
Effective Aperture
1/2 Pwr Beamwidth
Antenna Gain
Circuit Losses
Noise Figure
Noise Temperature
Antenna Temp
System Temperature
System G/T

Downlink Pwr Ratios

Boltzmann's Cnst
System Bandwidth
CNR Thermal
C/I Freq Reuse
C/I External Int
C/(N+I) Total Down
C/N₀ Down

End-to-end Parameters

The end-to-end parameters allow the total performance of the link to be analyzed. Availability, bit error rate, margin, etc. can now be investigated and tradeoffs made to obtain the desired performance.

<u>Link Total</u>
Origin
Destination
CNR _u
CNR _r
F
CNR _I
CNR _{Int}
CNR _C
CNR _d Available
C/N _o Available
Bandwidth
Data Rate
Available E _b /N _o
Required E _b /N _o
Margin

Appendix B: Proposed Equation Representation

The equations provided below represent those necessary for the initial kernel of the DSS.

Elevation Angle

$$d = [(h + r_e)^2 + r_e^2 - 2r_e(h + r_e)\cos\theta]^{1/2}$$

where d is the slant range,

h is the satellite altitude (35,784 km),

r_e is the earth's radius (6378 km), and

θ is the elevation angle.

Free Space Loss

$$FSL = (4\pi d/\lambda)^2$$

where d is slant range, and

λ is the wavelength.

Gain

$$\begin{aligned} G &= 4\pi A_e/\lambda^2 \\ &= 4\pi A_p/\lambda^2 \\ &= \eta(\pi D/\lambda)^2 \end{aligned}$$

where A_e is the effective antenna area,

λ is the carrier wavelength,

A is the antenna aperture area (the physical area of the antenna),
 η is the antenna efficiency, and
D is the antenna diameter.

Noise Temperature

$$P_n = kT_e B$$

$$T_e = T_b + (F - 1)290$$

where P_n is the thermal noise power,
k is Boltzmann's constant,
 T_e is the equivalent thermal noise temperature,
B is the radio frequency (rf) bandwidth of the receiving system,
 T_b is the antenna background noise, and
F is the receiver noise figure.

Required Bit Power-to-Noise Density

$$(C/N_0) = (E_b/N_0)R_b$$

where E_b/N_0 is the bit power-to-noise density, and
 R_b is the bit rate.

Appendix C: Sample Link Calculations and ROMC Discussion

The purpose of this Appendix is to present a simple example of a initial link analysis in the context of the DSS kernel proposed in this research. A design scenario is presented, from which the values of some parameters are derived. The link budget is then developed discussing the ROMC elements that are used at each step. Following this development, a discussion of the results and the direction along which the design would procede ends the Appendix.

In the strategic message system of the Canadian Forces, 75 bps message traffic from a number of bases and stations is combined at a concentrator then sent via commercial circuits to a node in the backbone system. Traffic destined for a base is routed from node to concentrator to the base. This example examines the feasibility of replacing the leased commercial circuits between the four concentrators and the western node with SATCOM links. The four concentrators (Nanaimo, Alder-grove, Edmonton, and Shilo) are connected to the node, Penhold, by 4800 bps lines.

The SATCOM link is to be EHF, as this is the current area of interest of the DCESR staff (Ewen, 1985). Canadian work with the Lincoln Experimental Satellite (LES) led to the selection of LES 9 as the space segment. Parameter values for the satellite and earth station are not precise. They were taken from several sources and thus represent "typical" values (Cummings, Pravin, and Richardi, 1979: 1423-1434; Mor-

gan, 1984: 1443; Pritchard, 1979: 6-7; Snider and Coomber, 1979: 433-434; and Tanaka, 1984: 1637-1644).

The data rate on the links is to be 4800 bps with a bit error rate of 10^{-6} . The desired availability is 99%. This availability could require large link margins for Nanaimo and Aldergrove. Both of these locations are on the west coast where there is significant rainfall. EHF is severely attenuated by rainfall. This represents the data that would be given the DECESR planner to begin the design of a SATCOM system.

In the following pages, the initial design of the system is developed. The process is presented sequentially. At each step the use of the DSS is outlined and a sample representation is presented.

Step 1. From the menu, the link analysis table representation is called. Although the entire table given in Appendix B could be used, I will only work with the general data portion.

Earth Station Name
Latitude
Longitude
Satellite Name
Satellite Location
Uplink Frequency
Downlink Frequency
Slant Range
Required BER
Required Data Rate
Modulation
Required E_b/N_0
Availability

Step 2. Using the Statement Language, the table is divided into one column per station and known data is entered into the table. A cursor movement technique and keyboard or a query and response method could be used to accomplish this. In the table below, the station names are abbreviated as follows: Nan = Nanaimo, Ald = Aldergrove, Ed = Edmonton, Pen = Penhold, and Shi = Shilo.

Earth Station Name	Nan	Ald	Ed	Pen	Shi
Latitude	49°N	49°N	53°N	52°N	50°N
Longitude	124°W	122°W	113°W	113°W	99°W
Satellite Name	LES 9				
Satellite Location					
Uplink Frequency					
Downlink Frequency					
Slant Range					
Required BER	10^{-6}				
Required Data Rate	4800 bps				
Modulation					
Required E_b/N_0					
Availability	99%				

Step 3. The data on the LES 9 is extracted from the data base and inserted into the table using the link function. If this data was not available in the data base, it could be directly entered from the keyboard. As part of the iterative design process for the DSS, the ability to have data about the satellite automatically passed to other portions of the link analysis table should be included. The satellite location and the up/downlink frequencies are entered as is the modulation type.

Earth Station Name	Nan	Ald	Ed	Pen	Shi
Latitude	49°N	49°N	53°N	52°N	50°N
Longitude	124°W	122°W	113°W	113°W	99°W
Satellite Name	LES 9				
Satellite Location	105.4W				
Uplink Frequency	36 GHz				
Downlink Frequency	38 GHz				
Slant Range					
Required BER	10^{-6}				
Required Data Rate	4800 bps				
Modulation	BPSK				
Required E_b/N_0					
Availability	99%				

Step 4. The next step is to calculate the slant range for each earth station. Off-line, I used a chart to determine the approximate elevation angle for each station. The slant range is calculated using

$$d = [(h + r_e)^2 + r_e^2 - 2r_e(h + r_e)\cos\phi]^{1/2}$$

where h is the satellite altitude (35,784 km), r_e is the earth's radius (6378 km), and ϕ is the elevation angle. Initially the DSS should the calculation of the slant range in the same manner. As the DSS evolves, this calculation could become a built-in function.

Earth Station Name	Nan	Ald	Ed	Pen	Shi
Latitude	49°N	49°N	53°N	52°N	50°N
Longitude	124°W	122°W	113°W	113°W	99°W
Satellite Name	LES 9				
Satellite Location	105.4M				
Uplink Frequency	36 GHz				
Downlink Frequency	38 GHz				
Slant Range (km)	36,777	36,777	36,842	36,777	36,976
Required BER	10^{-6}				
Required Data Rate	4800 bps				
Modulation	BPSK				
Required E_b/N_0					
Availability	99%				

Step 5. The minimum E_b/N_0 necessary to achieve the desired error performance is determined from tables in the technical data base or using off-line tables (eg Proakis, 1983: 162).

Earth Station Name	Nan	Ald	Ed	Pen	Shi
Latitude	49°N	49°N	53°N	52°N	50°N
Longitude	124°W	122°W	113°W	113°W	99°W
Satellite Name	LES 9				
Satellite Location	105.4W				
Uplink Frequency	36 GHz				
Downlink Frequency	38 GHz				
Slant Range (km)	36,777	36,777	36,842	36,777	36,976
Required BER	10^{-6}				
Required Data Rate	4800 bps				
Modulation	BPSK				
Required E_b/N_0	10.5 dB				
Availability	99%				

Step 6. I now begin the link calculations by calling the table for the uplink portion of the analysis.

Transmitter

Power (saturation)
Circuit Losses
Backoff
Antenna Diameter
Effective Aperture
1/2 Pwr Beamwidth
Antenna Gain
EIRP

Losses

Free Space Loss
Atmospheric Losses
Pointing Loss
Other Losses

Satellite Receiver

Antenna Diameter
Effective Aperture
1/2 Pwr Beamwidth
Antenna Gain
Circuit Losses
Noise Figure
Noise Temperature
Antenna Temp
System Temperature
System G/T

Uplink Power Ratios

Boltzmann's Cnst
System Bandwidth
C/N Thermal
C/I Freq Reuse
C/I External Int
C/(N+I) Total Up
C/N₀ Up

Step 7. Parameters in the table which are not to be included in the analysis are deleted and known information is entered. Note that all values in the table are in dB unless otherwise specified.

<u>Transmitter</u>	Nan	Ald	Ed	Pen	Shi
Power (saturation)					
Circuit Losses					
Antenna Diameter					
Antenna Gain					
EIRP					
<u>Losses</u>					
Free Space Loss					
Other Losses					
<u>Satellite Receiver</u>					
Antenna Gain	25	25	25	25	25
Noise Figure	7	7	7	7	7
Noise Temperature					
Ant Temp 308°K					
System Temperature					
System G/T					
<u>Uplink Power Ratios</u>					
Boltzmann's Cnst	-228.60	-228.60	-228.60	-228.60	-228.60
Sys Bwdth 1 GHz					
CNR Thermal					
C/N ₀ Up					

Step 8. At this point some initial assumptions must be made for system parameters. These assumptions are based on the case that there is not existing earth stations. Hence, I selected typical values for earth station antenna size, power, and noise temperature. I have also entered typical values for circuit losses and other propagation losses.

<u>Transmitter</u>	Nan	Ald	Ed	Pen	Shi
Power (saturation)	200 w	200 w	200 w	300 w	200 w
Circuit Losses	2	2	2	2	2
Antenna Diameter	1.2 m	1.2 m	1.2 m	11.5 m	1.2 m
Antenna Gain					
EIRP					
<u>Losses</u>					
Free Space Loss					
Other Losses	2	2	2	2	2
<u>Satellite Receiver</u>					
Antenna Gain	25	25	25	25	25
Noise Figure	7	7	7	7	7
Noise Temperature					
Ant Temp 308°K					
System Temperature					
System G/T					
<u>Uplink Power Ratios</u>					
Boltzmann's Cnst	-228.60	-228.60	-228.60	-228.60	-228.60
Sys Bwdth 1 GHz					
CNR Thermal					
C/N ₀ Up					

Step 2. Necessary values are converted to dB using $x_{dB} = 10 \log x$.

In the DSS this could be done automatically or by using a function key.

<u>Transmitter</u>	Nan	Ald	Ed	Pen	Shi
Power (saturation)	23.01	23.01	23.01	24.77	23.01
Circuit Losses	2	2	2	2	2
Antenna Diameter	1.2 m	1.2 m	1.2 m	11.5 m	1.2 m
Antenna Gain					
EIRP					
<u>Losses</u>					
Free Space Loss					
Other Losses	2	2	2	2	2
<u>Satellite Receiver</u>					
Antenna Gain	25	25	25	25	25
Noise Figure	7	7	7	7	7
Noise Temperature					
Ant Temp 308°K	24.89	24.89	24.89	24.89	24.89
System Temperature					
System G/T					
<u>Uplink Power Ratios</u>					
Boltzmann's Cnst	-228.60	-228.60	-228.60	-228.60	-228.60
Sys Bwdth 1 GHz	90	90	90	90	90
CNR Thermal					
C/N ₀ Up					

Step 10. The next step is to calculate the antenna gain. The equation representation is called and the equation for gain as a function of antenna diameter is found $G = (\pi D/\lambda)^2$ where λ is the wavelength and D is the antenna diameter. In this example, I have assumed a perfect antenna. The value of the gain is converted to dB and inserted in the table.

<u>Transmitter</u>					
Power (saturation)	23.01	23.01	23.01	24.77	23.01
Circuit Losses	2	2	2	2	2
Antenna Diameter	1.2 m	1.2 m	1.2 m	11.5 m	1.2 m
Antenna Gain	53.11	53.11	53.11	72.74	53.11
EIRP					
<u>Losses</u>					
Free Space Loss					
Other Losses	2	2	2	2	2
<u>Satellite Receiver</u>					
Antenna Gain	25	25	25	25	25
Noise Figure	7	7	7	7	7
Noise Temperature					
Ant Temp 308°K	24.89	24.89	24.89	24.89	24.89
System Temperature					
System G/T					
<u>Uplink Power Ratios</u>					
Boltzmann's Cnst	-228.60	-228.60	-228.60	-228.60	-228.60
Sys Bwdth 1 GHz	90	90	90	90	90
CNR Thermal					
C/N ₀ Up					

Step 11. I now calculate the EIRP = $P_T + G_T - L_{cct}$

<u>Transmitter</u>	Nan	Ald	Ed	Pen	Shi
Power (saturation)	23.01	23.01	23.01	24.77	23.01
Circuit Losses	2	2	2	2	2
Antenna Diameter	1.2 m	1.2 m	1.2 m	11.5 m	1.2 m
Antenna Gain	53.11	53.11	53.11	72.74	53.11
EIRP	74.12	74.12	74.12	95.51	74.12
<u>Losses</u>					
Free Space Loss					
Other Losses	2	2	2	2	2
<u>Satellite Receiver</u>					
Antenna Gain	25	25	25	25	25
Noise Figure	7	7	7	7	7
Noise Temperature					
Ant Temp 308°K	24.89	24.89	24.89	24.89	24.89
System Temperature					
System G/T					
<u>Uplink Power Ratios</u>					
Boltzmann's Cnst	-228.60	-228.60	-228.60	-228.60	-228.60
Sys Bwdth 1 GHz	90	90	90	90	90
CNR Thermal					
C/N ₀ Up					

Step12. The free space loss is now calculated. From the equations either $FSL = [(4\pi z)/\lambda]^2$ or $FSL_{Db} = 92.45 + 20 \log f + 20 \log z$ where z is the slant range (kilometers in the second equation), λ is the wavelength, and f is frequency in GHz. If the first equation is used, the result must be converted to dB.

<u>Transmitter</u>					
Power (saturation)	23.01	23.01	23.01	24.77	23.01
Circuit Losses	2	2	2	2	2
Antenna Diameter	1.2 m	1.2 m	1.2 m	11.5 m	1.2 m
Antenna Gain	53.11	53.11	53.11	72.74	53.11
EIRP	74.12	74.12	74.12	95.51	74.12
<u>Losses</u>					
Free Space Loss	214.88	214.88	214.90	214.88	214.93
Other Losses	2	2	2	2	2
<u>Satellite Receiver</u>					
Antenna Gain	25	25	25	25	25
Noise Figure	7	7	7	7	7
Noise Temperature					
Ant Temp 308°K	24.89	24.89	24.89	24.89	24.89
System Temperature					
System G/T					
<u>Uplink Power Ratios</u>					
Boltzmann's Cnst	-228.60	-228.60	-228.60	-228.60	-228.60
Sys Bwdth 1 GHz	90	90	90	90	90
CNR Thermal					
C/N ₀ Up					

Step 13. I next calculate the system temperature. The system temperature is the sum of the antenna and the receiver thermal noise temperature. Receiver noise temperature is given by $T_{eq} = (F - 1)290^{\circ}K$ where F is the noise figure (as a ratio). In this example, T_{eq} equals $1,163^{\circ}K$, and the system temperature is $1,471^{\circ}K$.

<u>Transmitter</u>					
Power (saturation)	23.01	23.01	23.01	24.77	23.01
Circuit Losses	2	2	2	2	2
Antenna Diameter	1.2 m	1.2 m	1.2 m	11.5 m	1.2 m
Antenna Gain	53.11	53.11	53.11	72.74	53.11
EIRP	74.12	74.12	74.12	95.51	74.12
<u>Losses</u>					
Free Space Loss	214.88	214.88	214.90	214.88	214.93
Other Losses	2	2	2	2	2
<u>Satellite Receiver</u>					
Antenna Gain	25	25	25	25	25
Noise Figure	7	7	7	7	7
Noise Temp $1,163^{\circ}K$	30.66	30.66	30.66	30.66	30.66
Ant Temp $308^{\circ}K$	24.89	24.89	24.89	24.89	24.89
Sys Temp $1,371^{\circ}K$	31.68	31.68	31.68	31.68	31.68
System G/T					
<u>Uplink Power Ratios</u>					
Boltzmann's Cnst	-228.60	-228.60	-228.60	-228.60	-228.60
Sys Bwdth 1 GHz	90	90	90	90	90
CNR Thermal					
C/N_0 Up					

Step 14. Calculate the satellite $G/T = G - T$.

<u>Transmitter</u>	Nan	Ald	Ed	Pen	Shi
Power (saturation)	23.01	23.01	23.01	24.77	23.01
Circuit Losses	2	2	2	2	2
Antenna Diameter	1.2 m	1.2 m	1.2 m	11.5 m	1.2 m
Antenna Gain	53.11	53.11	53.11	72.74	53.11
EIRP	74.12	74.12	74.12	95.51	74.12
<u>Losses</u>					
Free Space Loss	214.88	214.88	214.90	214.88	214.93
Other Losses	2	2	2	2	2
<u>Satellite Receiver</u>					
Antenna Gain	25	25	25	25	25
Noise Figure	7	7	7	7	7
Noise Temp 1,163°K	30.66	30.66	30.66	30.66	30.66
Ant Temp 308°K	24.89	24.89	24.89	24.89	24.89
Sys Temp 1,371°K	31.68	31.68	31.68	31.68	31.68
System G/T	-6.68	-6.68	-6.68	-6.68	-6.68
<u>Uplink Power Ratios</u>					
Boltzmann's Cnst	-228.60	-228.60	-228.60	-228.60	-228.60
Sys Bwdth 1 GHz	90	90	90	90	90
CNR Thermal					
C/N_0 Up					

Step 15. Calculate the uplink carrier-to-noise ratio

$$CNR_u = EIRP - FSL + G/T - L - K_b$$

<u>Transmitter</u>	Nan	Ald	Ed	Pen	Shi
Power (saturation)	23.01	23.01	23.01	24.77	23.01
Circuit Losses	2	2	2	2	2
Antenna Diameter	1.2 m	1.2 m	1.2 m	11.5 m	1.2 m
Antenna Gain	53.11	53.11	53.11	72.74	53.11
EIRP	74.12	74.12	74.12	95.51	74.12
<u>Losses</u>					
Free Space Loss	214.88	214.88	214.90	214.88	214.93
Other Losses	2	2	2	2	2
<u>Satellite Receiver</u>					
Antenna Gain	25	25	25	25	25
Noise Figure	7	7	7	7	7
Noise Temp 1,163°K	30.66	30.66	30.66	30.66	30.66
Ant Temp 308°K	24.89	24.89	24.89	24.89	24.89
Sys Temp 1,371°K	31.68	31.68	31.68	31.68	31.68
System G/T	-6.68	-6.68	-6.68	-6.68	-6.68
<u>Uplink Power Ratios</u>					
Boltzmann's Cnst	-228.60	-228.60	-228.60	-228.60	-228.60
Sys Bwdth 1 GHz	90	90	90	90	90
CNR Thermal	79.16	79.16	79.14	100.55	79.11
C/N ₀ Up					

Step 16. Calculate the uplink $C/N_0 = CNR_u + B$

<u>Transmitter</u>	Nan	Ald	Ed	Pen	Shi
Power (saturation)	23.01	23.01	23.01	24.77	23.01
Circuit Losses	2	2	2	2	2
Antenna Diameter	1.2 m	1.2 m	1.2 m	11.5 m	1.2 m
Antenna Gain	53.11	53.11	53.11	72.74	53.11
EIRP	74.12	74.12	74.12	95.51	74.12
<u>Losses</u>					
Free Space Loss	214.88	214.88	214.90	214.88	214.93
Other Losses	2	2	2	2	2
<u>Satellite Receiver</u>					
Antenna Gain	25	25	25	25	25
Noise Figure	7	7	7	7	7
Noise Temp 1,163°K	30.66	30.66	30.66	30.66	30.66
Ant Temp 308°K	24.89	24.89	24.89	24.89	24.89
Sys Temp 1,371°K	31.68	31.68	31.68	31.68	31.68
System G/T	-6.68	-6.68	-6.68	-6.68	-6.68
<u>Uplink Power Ratios</u>					
Boltzmann's Cnst	-228.60	-228.60	-228.60	-228.60	-228.60
Sys Bwdth 1 GHz	90	90	90	90	90
CNR Thermal	79.16	79.16	79.14	100.55	79.11
C/N_0 Up	169.16	169.16	169.14	190.55	169.11

Step 17. With the uplink calculations completed I now look at the downlink. Again I start with the representation table for the downlink.

Satellite Transmit

Power (saturation)
Circuit Losses
Backoff
Antenna Diameter
Effective Aperture
1/2 Pwr Beamwidth
Antenna Gain
Xmtd Signal Power
Xmtd N + I
EIRP

Losses

Free Space Loss
Atmospheric Losses
Pointing Loss
Other Losses

Earth Stn Receiver

Antenna Diameter
Effective Aperture
1/2 Pwr Beamwidth
Antenna Gain
Circuit Losses
Noise Figure
Noise Temperature
Antenna Temp
System Temperature
System G/T

Downlink Pwr Ratios

Boltzmann's Cnst
System Bandwidth
C/N Thermal
C/I Freq Reuse
C/I External Int
C/(N+I) Total Down
C/N₀ Down

Step 18. After deleting unwanted parameters, I entered known information and converted to dB. Receiver noise temperatures for the earth stations are again typical values from literature. They are 300°K for the concentrators and 220°K for the earth station at the Penhold node.

<u>Satellite Transmit</u>	Nan	Ald	Ed	Pen	Shi
Power 0.5 w	-3.01	-3.01	-3.01	-3.01	-3.01
Circuit Losses					
Antenna Gain	25	25	25	25	25
EIRP					
<u>Losses</u>					
Free Space Loss					
Other Losses					
<u>Earth Stn Receiver</u>					
Antenna Diameter	1.2 m	1.2 m	1.2 m	11.5 m	1.2 m
Antenna Gain					
Noise Temperature	24.77	24.77	24.77	23.42	24.77
Antenna Temp 100°K	20.00	20.00	20.00	20.00	20.00
System Temperature					
System G/T					
<u>Downlink Pwr Ratios</u>					
Boltzmann's Cnst	-228.60	-228.60	-228.60	-228.60	-228.60
Sys Bwdth 1 GHz	90	90	90	90	90
CNR Thermal					
C/N ₀ Down					

Step 19. As with the uplink, I assumed the circuit and other propagation losses.

<u>Satellite Transmit</u>	Nan	Ald	Ed	Pen	Shi
Power 0.5 w	-3.01	-3.01	-3.01	-3.01	-3.01
Circuit Losses	1	1	1	1	1
Antenna Gain	25	25	25	25	25
EIRP					
<u>Losses</u>					
Free Space Loss					
Other Losses	2	2	2	2	2
<u>Earth Stn Receiver</u>					
Antenna Diameter	1.2 m	1.2 m	1.2 m	11.5 m	1.2 m
Antenna Gain					
Noise Temperature	24.77	24.77	24.77	23.42	24.77
Antenna Temp 100°K	20.00	20.00	20.00	20.00	20.00
System Temperature					
System G/T					
<u>Downlink Pwr Ratios</u>					
Boltzmann's Cnst	-228.60	-228.60	-228.60	-228.60	-228.60
Sys Bwdth 1 GHz	90	90	90	90	90
CNR Thermal					
C/N ₀ Down					

Step 20. Calculate antenna gain, assuming an ideal antenna.

<u>Satellite Transmit</u>	Nan	Ald	Ed	Pen	Shi
Power 0.5 w	-3.01	-3.01	-3.01	-3.01	-3.01
Circuit Losses	1	1	1	1	1
Antenna Gain	25	25	25	25	25
EIRP					
<u>Losses</u>					
Free Space Loss					
Other Losses	2	2	2	2	2
<u>Earth Stn Receiver</u>					
Antenna Diameter	1.2 m	1.2 m	1.2 m	11.5 m	1.2 m
Antenna Gain	53.58	53.58	53.58	73.21	53.58
Noise Temperature	24.77	24.77	24.77	23.42	24.77
Antenna Temp 100°K	20.00	20.00	20.00	20.00	20.00
System Temperature					
System G/T					
<u>Downlink Pwr Ratios</u>					
Boltzmann's Cnst	-228.60	-228.60	-228.60	-228.60	-228.60
Sys Bwdth 1 GHz	90	90	90	90	90
CNR Thermal					
C/N ₀ Down					

Step 21. Calculate EIRP.

<u>Satellite Transmit</u>	Nan	Ald	Ed	Pen	Shi
Power 0.5 w	-3.01	-3.01	-3.01	-3.01	-3.01
Circuit Losses	1	1	1	1	1
Antenna Gain	25	25	25	25	25
EIRP	20.99	20.99	20.99	20.99	20.99
<u>Losses</u>					
Free Space Loss					
Other Losses	2	2	2	2	2
<u>Earth Stn Receiver</u>					
Antenna Diameter	1.2 m	1.2 m	1.2 m	11.5 m	1.2 m
Antenna Gain	53.58	53.58	53.58	73.21	53.58
Noise Temperature	24.77	24.77	24.77	23.42	24.77
Antenna Temp 100°K	20.00	20.00	20.00	20.00	20.00
System Temperature					
System G/T					
<u>Downlink Pwr Ratios</u>					
Boltzmann's Cnst	-228.60	-228.60	-228.60	-228.60	-228.60
Sys Bwdth 1 GHz	90	90	90	90	90
CNR Thermal					
C/N ₀ Down					

Step 22. Calculate free space loss.

<u>Satellite Transmit</u>	Nan	Ald	Ed	Pen	Shi
Power 0.5 w	-3.01	-3.01	-3.01	-3.01	-3.01
Circuit Losses	1	1	1	1	1
Antenna Gain	25	25	25	25	25
EIRP	20.99	20.99	20.99	20.99	20.99
<u>Losses</u>					
Free Space Loss	215.36	215.36	215.37	215.36	215.40
Other Losses	2	2	2	2	2
<u>Earth Stn Receiver</u>					
Antenna Diameter	1.2 m	1.2 m	1.2 m	11.5 m	1.2 m
Antenna Gain	53.58	53.58	53.58	73.21	53.58
Noise Temperature	24.77	24.77	24.77	23.42	24.77
Antenna Temp 100°K	20.00	20.00	20.00	20.00	20.00
System Temperature					
System G/T					
<u>Downlink Pwr Ratios</u>					
Boltzmann's Cnst	-228.60	-228.60	-228.60	-228.60	-228.60
Sys Bwdth 1 GHz	90	90	90	90	90
CNR Thermal					
C/N ₀ Down					

Step 23. Calculate G/T.

<u>Satellite Transmit</u>	Nan	Ald	Ed	Pen	Shi
Power 0.5 w	-3.01	-3.01	-3.01	-3.01	-3.01
Circuit Losses	1	1	1	1	1
Antenna Gain	25	25	25	25	25
EIRP	20.99	20.99	20.99	20.99	20.99
<u>Losses</u>					
Free Space Loss	215.36	215.36	215.37	215.36	215.40
Other Losses	2	2	2	2	2
<u>Earth Stn Receiver</u>					
Antenna Diameter	1.2 m	1.2 m	1.2 m	11.5 m	1.2 m
Antenna Gain	53.58	53.58	53.58	73.21	53.58
Noise Temperature	24.77	24.77	24.77	23.42	24.77
Antenna Temp 100°K	20.00	20.00	20.00	20.00	20.00
System Temperature	26.02	26.02	26.02	25.05	26.02
System G/T	27.56	27.56	27.56	48.16	27.56
<u>Downlink Pwr Ratios</u>					
Boltzmann's Cnst	-228.60	-228.60	-228.60	-228.60	-228.60
Sys Bwdth 1 GHz	90	90	90	90	90
CNR Thermal					
C/N ₀ Down					

Step 24. Calculate downlink CNR_r

<u>Satellite Transmit</u>	Nan	Ald	Ed	Pen	Shi
Power 0.5 w	-3.01	-3.01	-3.01	-3.01	-3.01
Circuit Losses	1	1	1	1	1
Antenna Gain	25	25	25	25	25
EIRP	20.99	20.99	20.99	20.99	20.99
<u>Losses</u>					
Free Space Loss	215.36	215.36	215.37	215.36	215.40
Other Losses	2	2	2	2	2
<u>Earth Stn Receiver</u>					
Antenna Diameter	1.2 m	1.2 m	1.2 m	11.5 m	1.2 m
Antenna Gain	53.58	53.58	53.58	73.21	53.58
Noise Temperature	24.77	24.77	24.77	23.42	24.77
Antenna Temp 100°K	20.00	20.00	20.00	20.00	20.00
System Temperature	26.02	26.02	26.02	25.05	26.02
System G/T	27.56	27.56	27.56	48.16	27.56
<u>Downlink Pwr Ratios</u>					
Boltzmann's Cnst	-228.60	-228.60	-228.60	-228.60	-228.60
Sys Bwdth 1 GHz	90	90	90	90	90
CNR Thermal	59.79	59.79	59.79	80.39	59.79
C/N ₀ Down					

Step 25. Calculate downlink C/N_0

<u>Satellite Transmit</u>	Nan	Ald	Ed	Pen	Shi
Power 0.5 w	-3.01	-3.01	-3.01	-3.01	-3.01
Circuit Losses	1	1	1	1	1
Antenna Gain	25	25	25	25	25
EIRP	20.99	20.99	20.99	20.99	20.99
<u>Losses</u>					
Free Space Loss	215.36	215.36	215.37	215.36	215.40
Other Losses	2	2	2	2	2
<u>Earth Stn Receiver</u>					
Antenna Diameter	1.2 m	1.2 m	1.2 m	11.5 m	1.2 m
Antenna Gain	53.58	53.58	53.58	73.21	53.58
Noise Temperature	24.77	24.77	24.77	23.42	24.77
Antenna Temp 100°K	20.00	20.00	20.00	20.00	20.00
System Temperature	26.02	26.02	26.02	25.05	26.02
System G/T	27.56	27.56	27.56	48.16	27.56
<u>Downlink Pwr Ratios</u>					
Boltzmann's Cnst	-228.60	-228.60	-228.60	-228.60	-228.60
Sys Bwdth 1 GHz	90	90	90	90	90
CNR Thermal	59.79	59.79	59.79	80.39	59.79
C/N_0 Down	149.79	149.79	149.79	170.39	149.79

Step 26. The calculation of the end-to-end CNR is now completed.

The link total representation is called.

<u>Link Total</u>
Origin
Destination
CNR _u
CNR _r
F
CNR _I
CNR _{Int}
CNR _C
CNR _d Available
C/N ₀ Available
Bandwidth
Data Rate
Available E _b /N ₀
Required E _b /N ₀
Margin

Step 27. Delete unwanted parameters and enter links and CNRs from previous sections.

<u>Link Total</u>								
Origin	Nan	Ald	Ed	Shi	Pen	Pen	Pen	Pen
Dest	Pen	Pen	Pen	Pen	Nan	Ald	Ed	Shi
CNR _u	79.16	79.16	79.14	79.11	100.55	100.55	100.55	100.55
CNR _r	80.39	80.39	80.39	80.39	59.79	59.79	59.80	59.83
CNR _d								
C/N ₀								
Bwdth	90	90	90	90	90	90	90	90
Data Rate								
Avail E _b /N ₀								
Req E _b /N ₀								
Margin								

Step 28. Calculate the available CNR_d

$$CNR_d = [(CNR_u)^{-1} + (CNR_r)^{-1}]^{-1}$$

where the CNR are expressed as ratios, not in dB.

<u>Link Total</u>								
Origin	Nan	Ald	Ed	Shi	Pen	Pen	Pen	Pen
Dest	Pen	Pen	Pen	Pen	Nan	Ald	Ed	Shi
CNR_u	79.16	79.16	79.14	79.11	100.55	100.55	100.55	100.55
CNR_r	80.39	80.39	80.39	80.39	59.79	59.79	59.80	59.83
CNR_d	76.72	76.72	76.71	76.69	59.79	59.79	59.80	59.83
C/N_o								
Bandth	90	90	90	90	90	90	90	90
Data Rate								
Avail E_b/N_o								
Req E_b/N_o								
Margin								

Step 29. Calculate the available C/N_o .

<u>Link Total</u>								
Origin	Nan	Ald	Ed	Shi	Pen	Pen	Pen	Pen
Dest	Pen	Pen	Pen	Pen	Nan	Ald	Ed	Shi
CNR_u	79.16	79.16	79.14	79.11	100.55	100.55	100.55	100.55
CNR_r	80.39	80.39	80.39	80.39	59.79	59.79	59.80	59.83
CNR_d	76.72	76.72	76.71	76.69	59.79	59.79	59.80	59.83
C/N_o	166.72	166.72	166.71	166.69	149.79	149.79	149.80	149.83
Bandth	90	90	90	90	90	90	90	90
Data Rate								
Avail E_b/N_o								
Req E_b/N_o								
Margin								

Step 30. Convert data rate to dB and calculate the available

E_b/N_0 .

<u>Link Total</u>								
Origin	Nan	Ald	Ed	Shi	Pen	Pen	Pen	Pen
Dest	Pen	Pen	Pen	Pen	Nan	Ald	Ed	Shi
CNR _u	79.16	79.16	79.14	79.11	100.55	100.55	100.55	100.55
CNR _r	80.39	80.39	80.39	80.39	59.79	59.79	59.80	59.83
CNR _d	76.72	76.72	76.71	76.69	59.79	59.79	59.80	59.83
C/N ₀	166.72	166.72	166.71	166.69	149.79	149.79	149.80	149.83
Bwdth	90	90	90	90	90	90	90	90
Data Rate	36.81	36.81	36.81	36.81	36.81	36.81	36.81	36.81
Avail E_b/N_0	129.91	129.91	129.90	129.88	112.98	112.98	112.99	113.02
Req E_b/N_0								
Margin								

Step 31. Enter the required E_b/N_0 and determine the margin.

<u>Link Total</u>								
Origin	Nan	Ald	Ed	Shi	Pen	Pen	Pen	Pen
Dest	Pen	Pen	Pen	Pen	Nan	Ald	Ed	Shi
CNR _u	79.16	79.16	79.14	79.11	100.55	100.55	100.55	100.55
CNR _r	80.39	80.39	80.39	80.39	59.79	59.79	59.80	59.83
CNR _d	76.72	76.72	76.71	76.69	59.79	59.79	59.80	59.83
C/N ₀	166.72	166.72	166.71	166.69	149.79	149.79	149.80	149.83
Bwdth	90	90	90	90	90	90	90	90
Data Rate	36.81	36.81	36.81	36.81	36.81	36.81	36.81	36.81
Avail E_b/N_0	129.91	129.91	129.90	129.88	112.98	112.98	112.99	113.02
Req E_b/N_0	10.5	10.5	10.5	10.5	10.5	10.5	10.5	10.5
Margin	119.41	119.41	119.40	119.38	102.48	102.48	102.49	102.52

Analysis. In this sample link budget there is ample margin. There would be no difficulties meeting the desired availability, although there is more margin than necessary. Design work would now try to reduce the margin and make it more reasonable. Initial areas to investigate could include modifying the antenna gains to reflect efficiency (typically 55% for dish antennas), including pointing error,

and modeling the non-linear amplifiers. Once the individual link budgets are reasonable, the question of multiple access can be addressed.

Bibliography

- Abramson, N., editor. "Satellite Communication Networks," Proceedings of the IEEE, 72: 1427-1645 (November, 1984).
- Alavi, Maryam and John C. Henderson. "An Evolutionary Strategy for Implementing a Decision Support System," Management Science, 27: 1309-1323 (November, 1981).
- Anthony, Robert N. Planning and Control Systems, A Framework for Analysis. Boston: Harvard University Graduate School of Business Administration, 1965.
- Bahl, Harrish C. and Raymond G Hunt. "A Framework for Systems Analysis for Decision Support Systems," Information & Management, 7: 121-131 (1984).
- Balaban, P., K.S. Shannugan, and B.W. Stuck, editors. "Computer-Aided Modeling, Analysis, and Design of Communication Systems," IEEE Journal on Selected Areas in Communication Systems, SAC-2K: (January 1984).
- Carlson, Eric D. "An Approach for Designing Decision Support Systems," Building Decision Support Systems, edited by John L. Bennett. Reading, Mass: Addison-Wesley Publishing Company, Inc., 1983.
- Cummings, William C., Pravin C. Jain, and Leon J. Richardi. "Fundamental Performance Characteristics that Influence EMF MILSATCOM Systems," IEEE Transactions on Communications, COM-27: 1423-1434 (October 1979).
- Eisner, Howard. "CASE: Computer-Aided Systems for C³ Systems." Signal, 38: 15-21 (July 1981).
- Elam, Dr. Joyce J. Decision Support Systems. Lecture Materials. The Institute for Professional Education, Arlington, Virginia. Undated.
- Elam, Joyce J and Robert F. Schneider. "Optimization-Based Decision Support Systems." Unpublished article, 1983.
- Ewen, LCol Glen. DCESR-3 Personal Interviews. National Defence Headquarters, Ottawa, Ontario, Canada, 27-29 September 1985.
- Fehér, Dr. Kamilo. Digital Communications Satellite/Earth Station Engineering, Forward by S. Astrain. Englewood Cliffs, NJ: Prentice-Hall Inc., 1983.

Feher, K., L.S. Greenstein, D. Lombard, and L. Pollack editors. "Special Issue on Digital Satellite Communications," IEEE Journal on Selected Areas in Communications, SAC-1: 2-231 (January, 1983)

Fick, Goran and Ralph H. Sprague, Jr. "Introduction," Decision Support Systems: Issues and Challenges, Volume 11, edited by Goran Fick and Ralph H. Sprague, Jr. Elmsford, N.Y.: Pergamon Press Inc., 1980.

Gagliardi, Robert M. Satellite Communications. Belmont, CA: Lifetime Learning Publications, 1984.

Harrison, E. Frank. The Managerial Decision-Making Process (Second Edition). Boston: Houghton Mifflin, 1981.

Hemmings, David F. "The Corporate Network -- System and Services," IEEE Communications Magazine, 20: 12-15 (January 1982).

Henderson, John C. and Paul C. Nutt. "The Influence of Decision Style on Decision Making Behavior," Management Science, 26: 371-386 (April 1980).

Henderson, John C., Reuben R. McDaniel Jr., and G. R. Wagner. "The Implementation of Operations Research/Management Science Modeling Techniques," IEEE Transactions on Engineering Management, EM-27: 12-18 (February 1980).

Hovanessian, S.A. "Research and Development of a Large-Scale Electronic System," IEEE Transactions on Engineering Management, EM-22: 94-101 (August 1975).

Huber, George P. "Organizational Science Contributions to the Design of Decision Support Systems," Decision Support Systems: Issues and Challenges, edited by Goran Fick and Ralph H. Sprague Jr. Oxford, England: Pergamon Press Ltd., 1980.

Hurst, E. Gerald Jr., David N. Ness, Thomas J. Gambino, and Thomas H. Johnson. "Growing DSS: A Flexible Evolutionary Approach," Building Decision Support Systems, edited by John L. Bennett, Reading, Mass: Addison-Wesley Publishing Company Inc., 1983.

Jabbari, Bijan. "Cost Effective Networking Via Digital Satellite Communications," Proceedings of the IEEE, 72: 1556-1563 (November 1984).

Keen, Peter G. W. and Michael S. Scott Morton. Decision Support Systems: An Organizational Perspective. Reading, Mass: Addison-Wesley Publishing Company, 1978.

Keen, Peter G.W. "Decision Support Systems: A Research Perspective," Decision Support Systems: Issues and Challenges, Volume 11, edited by Goran Fick and Ralph H. Sprague, Jr. Elmsford, N.Y.: Pergamon Press Inc., 1980a.

----- "Decision Support Systems: Translating Analytic Techniques into Useful Tools," Sloan Management Review, 21: 33-44 (Spring 1980b).

Koble, Capt Roger D. Applications of Computers as an Aid to Decision-Making in Air Force System Program Offices. MS Thesis, GSN/855-20. School of Systems and Logistics, Air Force Institute of Technology, (AU), Wright-Patterson AFB OH, September 1985.

Krant, Captain D. "Sea King Replacement Project: Application of Evaluation Methodology-Structuring the Evaluation Plan," Second International Symposium on Military Operational Research, July 1985.

Marsten, Richard B. "Service Needs and System Architecture in Satellite Communications," IEEE Communications Society Magazine 15: 14-23 (May 1977).

Martin, James. Communications Satellite Systems. Englewood Cliffs, NJ: Prentice-Hall Inc., 1978.

Mason, Richard D. and E. Burton Swanson. Measurement for Management Decision. Reading, Mass: Addison-Wesley Publishing Company, 1981.

McKenney, James L. and Peter G.W. Keen. "How Managers' Minds Work," Harvard Business Review, 52: 79-90 (May-June 1974).

Moore, Jeffrey H. and Michael B. Chang. "Meta-Design Considerations in Building DSS". Building Decision Support Systems edited by John L. Bennett. Reading, Mass: Addison-Wesley Publishing Company Inc., 1983.

Morgan, Walter L. "Satellite Locations-1984," Proceedings of the IEEE, 72: 1434-1444 (November, 1984).

Pearce, Dr. LeRoy, Research Scientist. Personal Interview. Communications Research, Ottawa, Ontario, Canada, 27 September 1985.

Perry, CDR Albert K. "Advanced DOD Military Satellite Communications," Conference Record of the IEEE International Conference on Communications June 13-17, 1982: 6M65.1-6M.5.4 IEEE Press, New York, N.Y. (1982).

Pritchard, Wilbur L. "Satellite Communication - An Overview of the Problems and Programs," Satellite Communications, edited by Harry L. Van Trees. New York, New York: IEEE Press, 1979.

Proakis, John B. Digital Communications. New York: McGraw-Hill Book Company, 1982.

Rensma, Major Peter H. and Captain Randall W. Chapman. A Decision Support Methodology for Space Technology Advocacy. MS thesis, AFIT/GSO/OS/84D-4. School of Engineering, Air Force Institute of Technology (AU). Wright-Patterson AFB OH, December 1984.

Retnadas, C. "Satellite Multiple Access Protocols," IEEE Communications Magazine, 18: 16-20 (September 1980).

Saaty, Thomas L. "Priority Setting in Complex Problems," IEEE Transactions on Engineering Management, EM-30: 140-155 (August, 1983).

Saaty, Thomas L. Decision Making for Leaders. Belmont, Cal.: Lifetime Learning Publications, 1982a.

Sage, Andrew P. Methodology for Large-Scale Systems. New York, N.Y.: McGraw-Hill Book Company, 1977.

Shanmugan, K. San "Communication Systems Simulation-A Review" Proceedings of the International Conference on Systems, Man, and Cybernetics. 323-326. New York: IEEE Press, 1983.

Simon, Herbert A. The New Science of Management Decision. New York, N.Y.: American Book - Stratford Press, Inc., 1960.

Sklar, Bernard. "Structured Overview of Digital Communications--a Tutorial Review--Part I," IEEE Communications Magazine, 21: 4-17 (August 1983).

Sklar, Bernard. "What the System Link Budget Tells the System Engineer, or How I Learned to Count in Decibels," A Version of this paper appears in the Proceedings of the International Telemetering Conference, San Diego, November 1979.

Snider, David M., and David B. Cooper. "Satellite-to-Satellite Data Transfer and Control," Satellite Communications, edited by Harry L. Van Trees. New York: IEEE Press, 1979.

Spilker, James J., Jr. Digital Communications by Satellite. Englewood Cliffs, N.J.: Prentice-Hall Inc., 1977.

Sprague, Ralph H., Jr. and Eric D. Carlson. Building Effective Decision Support Systems. Englewood Cliffs, N.J.: Prentice-Hall, Inc., 1982.

Sprague, Ralph H. "A Framework for the Development of Decision Support Systems," MIS Quarterly, 4: 1-26(December 1980a).

-----, "A Framework for Research on Decision Support Systems," Decision Support Systems: Issues and Challenges, Volume 11, edited by Goran Fick and Ralph H. Sprague, Jr. Elmsford, N.Y.: Pergamon Press Inc., 1980b.

Stabell, Charles B. "A Decision-Oriented Approach to Building DSS," Building Decision Support Systems, edited by John L. Bennett. Reading, Mass: Addison-Wesley Publishing Company, 1983.

Steward, Donald V. Systems Analysis and Management. New York: Pitrocelli Books Inc., 1981a.

Steward, Donald V. "The Design Structure System: A Method for Managing the Design of Complex Systems," IEEE Transactions on Engineering Management, EM-28: 71-74 (August 1981b).

Tanaka, Rjoichi. "30/20 GHz Domestic Satellite Communication System in the Public Communication Network of Japan: Design and Operation," Proceedings of the IEEE, 72: 1637-1644 (November, 1984).

Thierauf, Robert J. Decision Support Systems for Effective Planning and Control: A Case Study Approach. Englewood Cliffs, N.J.: Prentice-Hall, 1982.

Van Trees, Harry L. editor. Satellite Communications. IEEE Press Selected Reprint Series, New York: IEEE Press, 1979a.

Wu, William W. The Elements of Digital Satellite Communication, Volume 1. Rockville, Maryland: Computer Science Press, 1984.

Zeleny, Milan. Multiple Criteria Decision Making. New York: McGraw-Hill Book Company, 1982.

VITA

Major J. Robert Leitch was born 12 May, 1950 in Edmonton, Alberta, Canada. He graduated from High School in Ottawa, Ontario in 1968 and entered College Militaire Royal de St. Jean, P.Q.. Following a transfer, he graduated from the Royal Military College of Canada in 1973 with the degree of Bachelor of Engineering (Electrical). He has served in communications and electronics maintenance positions on radar stations and in operations on communications research stations. He has been a training officer at the Canadian Forces School of Communications and Electronics and a staff officer in Canadian Forces Communication Command. He was appointed Chief Ground Environment Officer and Deputy Commanding Officer at CFS Beausejour in August 1982, where he served until entering the School of Engineering, Air Force Institute of Technology, in June 1984.

Permanent address: 2606 - 500 Laurier Avenue W.
Ottawa, Ontario
Canada K1R 5E1

END

FILMED

6-86

DITIC