

Best Available Copy

2

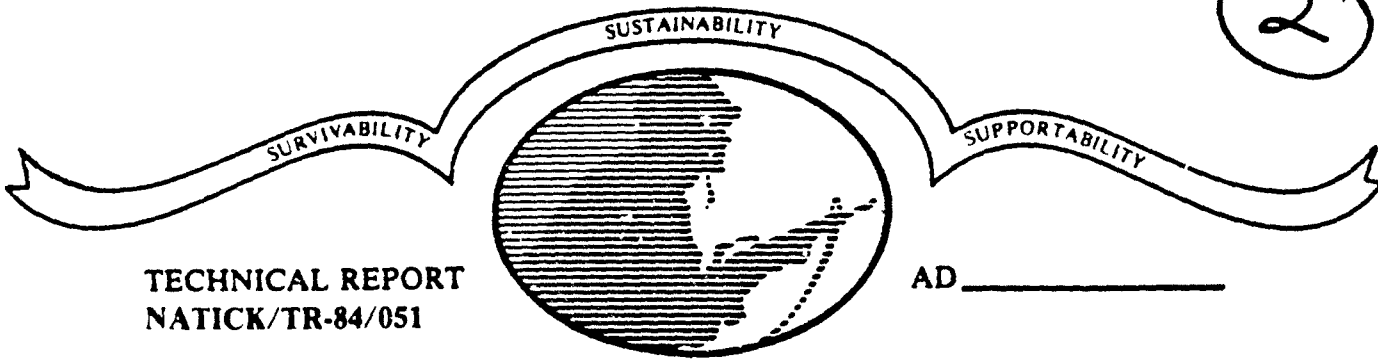

TECHNICAL REPORT  
NATICK/TR-84/051

AD \_\_\_\_\_

# DRAFT TECHNICAL MANUAL FOR TRANSPORTABLE HELICOPTER ENCLOSURE

DTIC FILE COPY AD-A164 557

BY  
ARTHUR G. CARR  
ARTHUR W. CLARIDGE

DECEMBER 1984

20030121028

DTIC  
ELECTE  
FEB 18 1986

S D

APPROVED FOR PUBLIC RELEASE;  
DISTRIBUTION UNLIMITED

UNITED STATES ARMY NATICK  
RESEARCH AND DEVELOPMENT CENTER  
NATICK, MASSACHUSETTS 01760-5005

AERO-MECHANICAL ENGINEERING LABORATORY

RR

Disclaimers

The findings contained in this report are not to be construed as an official Department of the Army position unless so designated by other authorized documents.

Citation of trade names in this report does not constitute an official endorsement or approval of the use of such items.

DESTRUCTION NOTICE

For classified documents, follow the procedures in DoD 5200.1-R, Chapter IX or DoD 5220.22-M, "Industrial Security Manual," paragraph 19. For unclassified documents, destroy by any method which precludes reconstruction of the document.

Unclassified

SECURITY CLASSIFICATION OF THIS PAGE (When Data Entered)

REPORT DOCUMENTATION PAGE		READ INSTRUCTIONS BEFORE COMPLETING FORM
1. REPORT NUMBER NATICK/TR-84/051	2. GOVT ACCESSION NO. -10. A164 557	3. RECIPIENT'S CATALOG NUMBER
4. TITLE (and Subtitle)  DRAFT TECHNICAL MANUAL FOR TRANSPORTABLE HELICOPTER ENCLOSURE	5. TYPE OF REPORT & PERIOD COVERED Final 1982	
	6. PERFORMING ORG. REPORT NUMBER	
7. AUTHOR(s)  Arthur G. Carr Arthur W. Claridge	8. CONTRACT OR GRANT NUMBER(s)	
9. PERFORMING ORGANIZATION NAME AND ADDRESS Aero-Mechanical Engineering Laboratories, US Army Natick Research & Development Center Natick, MA 01760-5017	10. PROGRAM ELEMENT, PROJECT, TASK AREA & WORK UNIT NUMBERS  1E464713DL40	
11. CONTROLLING OFFICE NAME AND ADDRESS	12. REPORT DATE December 1984	
	13. NUMBER OF PAGES 65	
14. MONITORING AGENCY NAME & ADDRESS (if different from Controlling Office)	15. SECURITY CLASS. (of this report)  Unclassified	
	15a. DECLASSIFICATION/DOWNGRADING SCHEDULE	
16. DISTRIBUTION STATEMENT (of this Report)  Approved for public release: distribution unlimited.		
17. DISTRIBUTION STATEMENT (of the abstract entered in Block 20, if different from Report)		
18. SUPPLEMENTARY NOTES  fr. p. iii		
19. KEY WORDS (Continue on reverse side if necessary and identify by block number)  TRANSPORTABLE HELICOPTER ENCLOSURE HELICOPTER MODULAR TENTS;  TRANSPORTABLE INSTRUCTIONAL SHELTERS GUIDELINES, TRAINING;  MANUAL.		
20. ABSTRACT (Continue on reverse side if necessary and identify by block number) This report is an instructional manual for the Transportable Helicopter Enclosure. It will provide erection, striking and maintenance procedures for personnel at both the Aviation Unit Maintenance and Aviation Intermediate Maintenance levels. This manual was prepared for Operational Testing I 27 Sept - 13 December, 1982.		

PREFACE

This manual is for the use of personnel responsible for the operation and maintenance of this Transportable Helicopter Enclosure. (THE). This manual provides the user and maintenance personnel with the necessary instructions to use the shelter and to perform required maintenance services. The manual was initiated for use during Operational Test one which started in September 1982 but is applicable to all users of the THE. The final draft was completed in August 1982, although many revisions have been made since that date. Thanks are due everyone involved with the THE for help in determining the easiest procedure and simplest instructions for all future users, especially to Pam Churchill for her patience and determination in typing the numerous revisions.

1.000.125  
2  
1.002



Accession For	
NTIS CRA&I	<input checked="" type="checkbox"/>
DTIC TAB	<input type="checkbox"/>
Unannounced	<input type="checkbox"/>
Justification	
By	
Distribution /	
Availability Codes	
Dist	Avail and/or Special
A-1	

## TABLE OF CONTENTS

	Page
Preface	iii
List of Figures	vii
Chapter I - Introduction	1
Section I - General	1
Scope	1
Maintenance Forms, Records and Reports	1
Reporting of Improvements	1
Section II - Description	2
Chapter 2 - Operating Instructions	5
Section I - Erection Procedures	5
Site Selection	5
Template Layout	6
Anchor Installation	8
Template Removal	9
Cover Layout and Section Alignment	10
Endwall Sections	11
Intermediate Arch Sections	11
Leaning Arch Sections	12
Lacing Procedures (Becketing)	14
Manifold Layout and Initial Anchoring	18
Connection of Blower to Generator	22
Inflation Instructions	24
Tie Down Procedure	25
Endwall Door Operation	26
Emergency Exits	27
Environmental Control Ducts	27
Shelter Extension	28
Section II - Striking Procedures	32
Folding Endwall	34
Folding Leaning Arch Section	36
Folding Intermediate Arch Section	38
Section III - Operation Under Unusual Conditions	39
Extreme Cold	39
Wet Climate	40
High Wind Conditions	40
Blackout Curtain Installation	40

TABLE OF CONTENTS (cont'd)

	Page
Chapter 3 - Operator's Maintenance Instructions	41
Section I - Operator's Tools and Equipment	41
Section II - Maintenance Checks and Services	41
General	41
Daily Preventive Checks and Services	42
Checklist 1 - Daily Maintenance Checks and Services	43
Section III - Operator's Maintenance	45
Checklist 2 - Component Listing	47
Ground Anchor Layout Template Dimensions	48
Section IV - Field Expedient Repairs	49
Single Arch Tube Inflation Procedures	51
Section V - Maintenance Allocation Chart	

## LIST OF FIGURES

Figure	Page
1. Transportable Helicopter Enclosure	3
2. Assembly sections of the THE	4
3. Cables, steps three and four	6
4. Cables, step five	6
5. Cables, step seven	7
6. Finished template	7
7. Ground anchor installation equipment	8
8. Section cover layout diagram	10
9. Endwall section	11
10. Intermediate arch	12
11. Leaning arch	12
12. Arrows at center of section	13
13. Kneel in between the sections and next to the center arrows	13
14. Layout all of the section and align arrows	13
15. Insert lace through grommet	14
16. Insert lace through loop in lace before	14
17. Pull tight	14
18. Becket lacing procedure	14
19. Place red loop through red grommet	15
20. Insert red loop through loop of lace before it	15
21. Pull back towards last lace	15
22. Insert red lace through loop of last lace	15
23. Pull back towards the first lace	16

LIST OF FIGURES (cont'd)

Figure	Page
24. Pull taut	16
25. Slide red lace under first lace	16
26. Tie off with half hitch knot	16
27. Tie off procedure	17
28. Unwrap and find the capped end	18
29. Walk the manifold around the sides of the shelter	18
30. Manifold and check valve hose	18
31. Arch tube check valve	19
32. Check valve position	19
33. Check connection to be sure they are not twisted	19
34. Connect manifold to the manifold extension	20
35. Manifold junction	20
36. Secure the manifold extension to the junction	20
37. Connect the six foot extension to the blower	20
38. Manifold layout diagram	21
39. Attach anchor strap to V-ring of arch tube	21
40. Connect snap hook of endwall cables to V-ring on endwall arch	21
41. Pull zipper down one foot	21
42. Generator terminals	22
43. Blower cable connected to generator	22
44. Blower	23
45. Observe rotation while turning on	23
46. Help the arch tubes to inflate	24



LIST OF FIGURES (cont'd)

Figure	Page
47. Shelter ready for tie down	24
48. Anchoring of arch tube base	25
49. Sod cloth anchoring	25
50. Attach endwall cables ground anchor strap	26
51. Endwall (inside)	26
52. Environmental control duct entering shelter (inside)	27
53. Environmental control duct entering shelter (outside)	27
54. Emergency exit (inside)	27
55. Emergency exit (outside)	27
56. Extension ground anchor layout cable	30
57-63. Folding endwall	34
65-67. Folding leaning arch	36
68-71. Folding intermediate arch	38
72. Ground anchor layout template dimensions	47
Checklist 1. Daily maintenance checks and services	42
Checklist 2. Component listing	45
Maintenance Allocation Chart	51

OPERATOR'S MANUAL FOR TRANSPORTABLE HELICOPTER ENCLOSURE

CHAPTER I

INTRODUCTION

Section 1. General

1-1. Scope

a. This operator's manual for the Transportable Helicopter Enclosure (THE) is for the use of personnel responsible for the operation and maintenance both at Aviation Unit Maintenance (AVUM) and Aviation Intermediate Maintenance (AVIM) levels. Personnel responsible for the operation of the THE will also be called the user.

b. The manual provides the user and maintenance personnel with the necessary instruction to use the enclosure and to perform required maintenance services in accordance with the Maintenance Allocation Chart in Chapter 3, Section VII.

1-2. Maintenance Forms, Records and Report

The maintenance forms, and reports will be maintained in accordance with the procedure outlined in TM-38-750.

1-3. Reporting of Improvements

The direct reporting of errors, omissions, and recommendations for improving this manual is authorized and encouraged. DA Form 2028 (Recommended Changes to DA Publications) will be used for reporting these improvements. This form will be completed in triplicate using pen, pencil or typewriter and will be forwarded direct to Commander, US Army Natick Research and Development Center, ATTN: STRNC-USO, Kansas Street, Natick, MA 01760.

## Section II. Description

The Transportable Helicopter Enclosure (THE) is a shelter in which Utility, Scout, and Attack helicopters in the forward areas of combat can be inspected and repaired under blackout or poor weather conditions. The entire shelter may be transported in a utility helicopter or a 1-1/2 ton truck or larger vehicle. The outside dimensions of the standard shelter are 81 ft long, 23 ft high and 33 ft wide, although because it is modular the length may be increased or decreased by the addition or subtraction of sections.

The THE is constructed so that it may be broken down into seven easily transportable parts. The sections of the THE are the "leaning arch," the "intermediate arch" and the "endwall" section (see Figure 2). These sections are connected together to form a complete shelter that allows enough room to work on a helicopter with ample room for maintenance and test equipment.

The leaning arch section is composed of two air-inflated arch tubes leaning together and meeting at the top. Between two arches is a weather barrier of coated polyester fabric.

The intermediate arch section is composed of a central, inflated arch with a weather barrier of coated polyester fabric on either side to connect with the leaning arches. These two sections together form the basic modules of the leaning arches. The standard THE has three leaning arch sections and two intermediate sections. These five pieces lace together to form a structure with eight inflated arch tubes (see Figure 2). The two endwalls cover the ends of the shelter to protect against wind and to provide complete coverage for use under blackout conditions. The THE is designed to withstand 10 lb of snow load, winds of 50 mph and gusts of up to 65 mph.

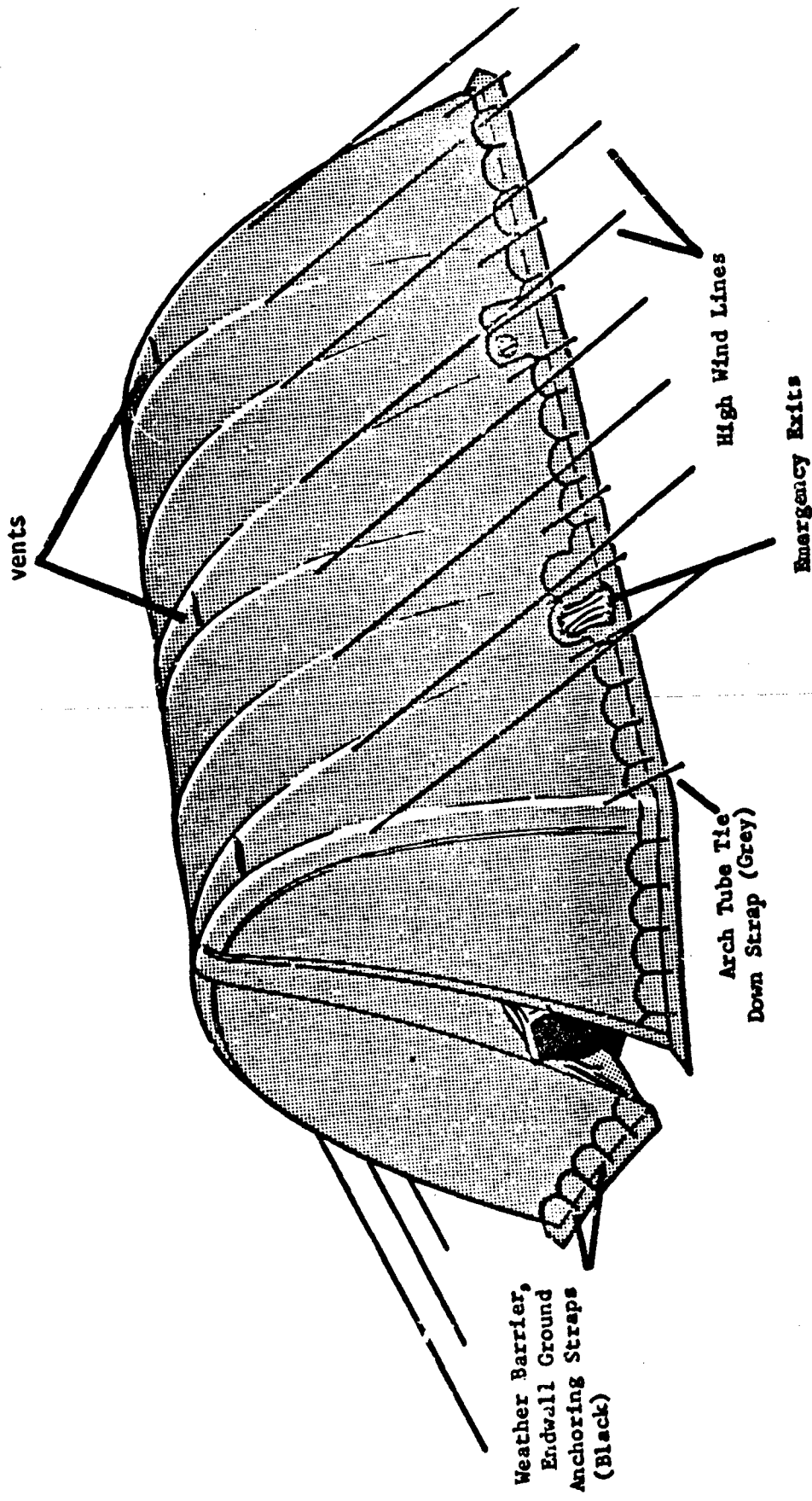

vents

High Wind Lines

Emergency Exits

Arch Tube Tie  
Down Strap (Grey)

Weather Barrier,  
Endwall Ground  
Anchoring Straps  
(Black)

Figure 1. Transportable Helicopter Enclosure

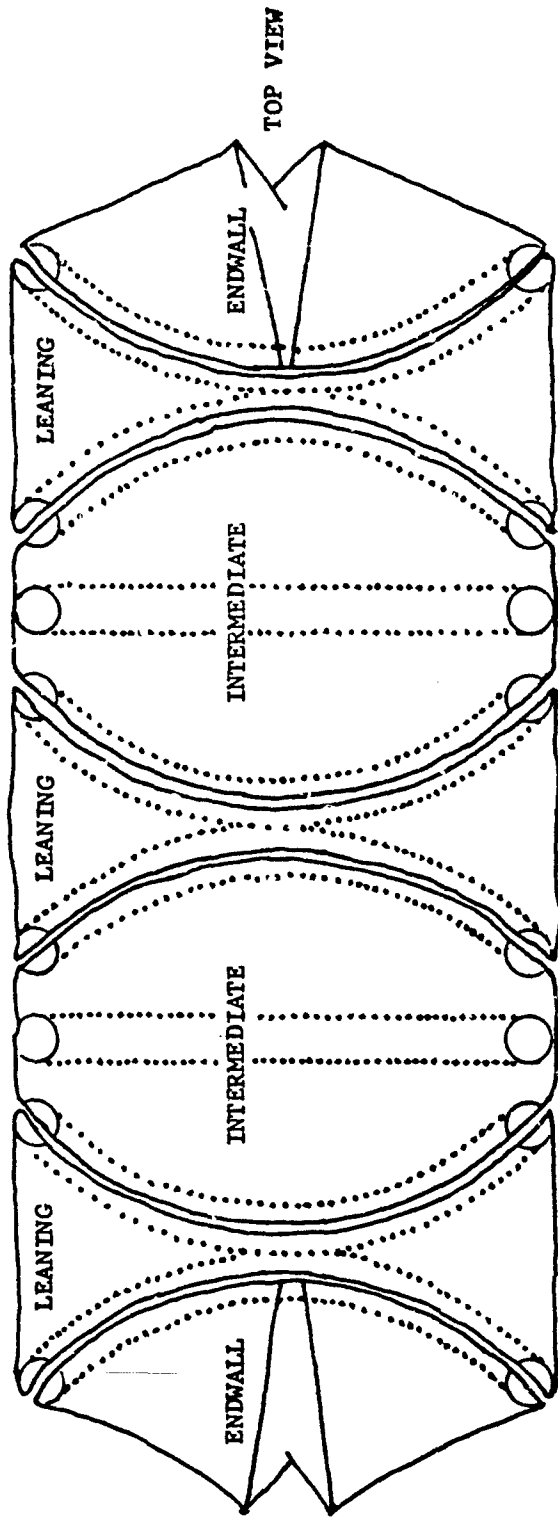
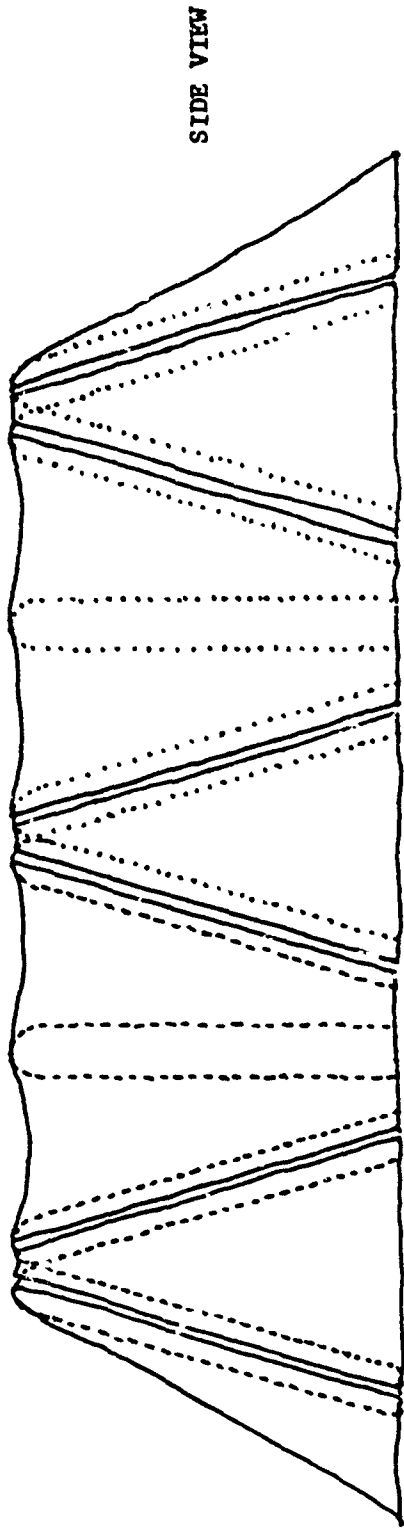

Figure 2. Assembly sections of the THE

## CHAPTER 2

### OPERATING INSTRUCTIONS

#### Section 1. Erection Procedures

The erection procedure is broken down into steps. These are discussed individually in the following order.

- a. Site Selection
- b. Template Layout
- c. Anchor Installation
- d. Template Removal
- e. Cover Layout and Section Alignment
- f. Lacing Procedures (Becketing)
- g. Manifold Layout and Initial Anchorage
- h. Connection of Blower to Generator
- i. Inflation Instruction
- j. Tiedown Procedures
- k. Endwall Operation
- l. Shelter Extension

#### a. Site Selection

The first step in the erection of the THE is the site selection. The site selected for the THE should take into account the movement of helicopters in and out of both ends, the relationship to the landing site and to the rest of the installation. The site should be level with good drainage. If drainage is questionable, the area must be properly trenched to ensure adequate drainage away from the shelter. The site selected for the shelter must be cleared of rocks, stumps, and other debris that will damage the shelter fabric during the erection procedures. Fill all holes and level all mounds that might interfere with a reasonably level and smooth area in the erected shelter.

b. Template Layout

The THE has an anchoring system of two parts. The primary anchoring system consists of ground anchor assemblies securing the arch tubes and endwalls and tent pins securing the arch tube bases and sod cloth. The secondary anchoring is for highwind and will be included in Section III on unusual conditions.

The layout template will act as a guide in determining the placement of the 52 primary ground anchors of the THE. The template will be unwound from the template holder while walking in the following steps.

1. Remove the template from the erection kit, untie the black ring and stake it to the ground. This is the first corner.
2. Unwind the cable until you reach the silver ring, be sure the cable is straight and taut, and stake the ring to the ground.
3. Turn to the right, reach the second silver ring and have someone hold it. (See Figure 3.)
4. Turn to the right again, unwind this to the silver ring and have someone hold it. (See Figure 3.)

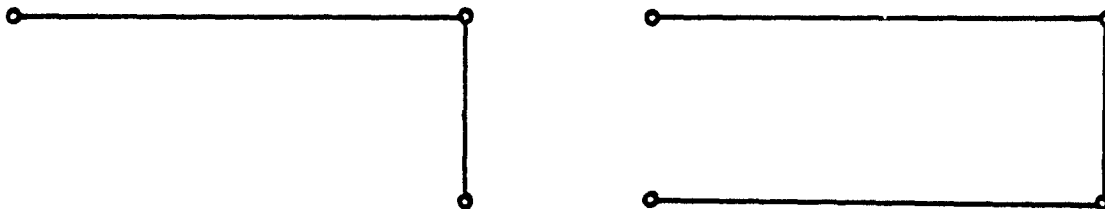

Figure 3. Cables, steps three and four

5. Turn to the right again, disconnect the black snap hook from the template holder, connect the hook to the first black ring. (See Figure 4.)

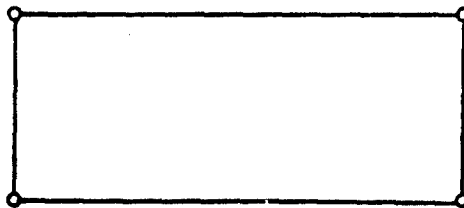

Figure 4. Cables, step five

6. Disconnect the yellow snap hook from the red rings and connect to the yellow ring at the center of the template.

**NOTE: BE SURE THE TEMPLATE CABLES ARE NOT TWISTED.**

7. Pull all of the cables taut and pin the two corners being held. The template should now look like Figure 5.

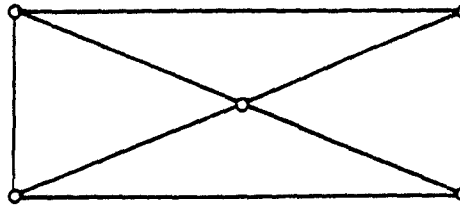

Figure 5. Cables, step seven

8. Remove the blue snaps from the corner rings and snap each to the nearest blue ring.

NOTE: WITHOUT TAUT CABLES, THE TEMPLATE WILL NOT BE RECTANGULAR AND THE GROUND ANCHOR WILL BE MISLAID.

The template when finished should look like Figure 6.

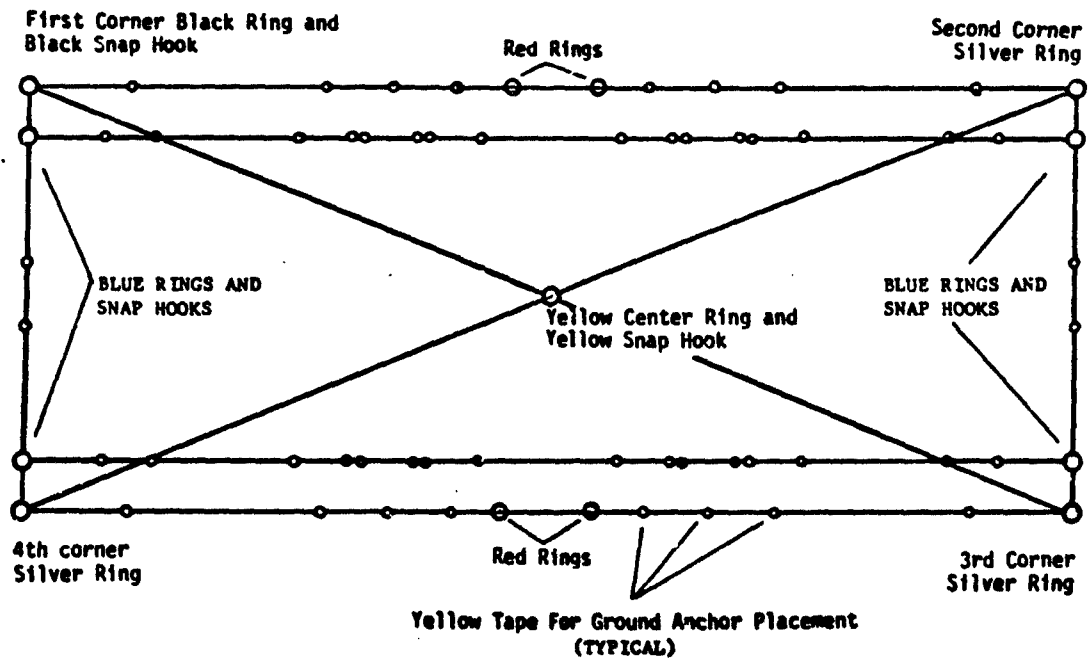

Figure 6. Finished template



### c. Anchor Installation

The arrowhead ground anchors supplied with the THE should each be installed two inches from the cable template and in line with the yellow marks.

NOTE: BE CAREFUL NOT TO HARM THE TEMPLATE WHEN INSTALLING THE GROUND ANCHORS, AND AGAIN, BE CAREFUL NOT TO TRIP OVER THE CABLES.

The ground anchors for the THE are installed with the following equipment (see Figure 7.)

- a. 12 lb Sledge
- b. Driving Rod Cap
- c. Driving Rod
- d. Driving Rod Holder
- e. Ground Anchor

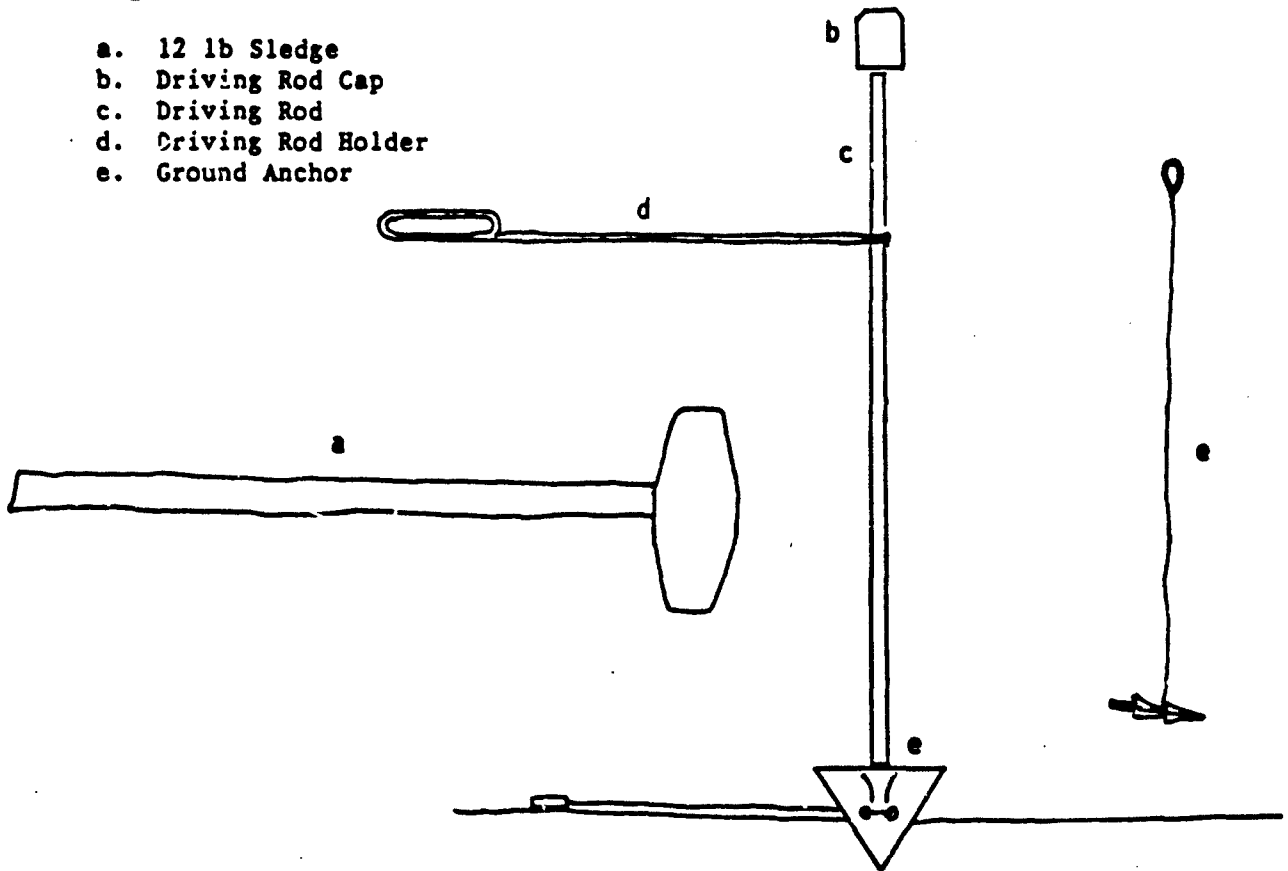

The ground anchors are installed in the following sequence:

1. Place ground anchor point down about two in into the ground in line with the yellow marks and two in away from the outside of the cable. Use the 2-1/2 lb hammer included in the erection kit if necessary. Be sure the ground anchor cable is untangled and out of the way.
2. Place the hole in the end of the driving rod on the pin at top of ground anchor and hold upright.
3. Place driving holder around driving rod and eight in down from top.
4. Place driving head on the top of the driving rod and stand back.

5. Second man should drive rod. Be careful to hit squarely and drive rod until ground anchor cable end loop touches the ground.
6. Remove driving head, driving rod holder and driving rod and place to the side.
7. To assist in setting the anchor, place a tent pin through the ground anchor loop to act as a handle.
8. Pull firmly. This is called setting the anchor and it puts the arrowhead point in the proper position to hold its maximum tension.
9. Remove 20 grey ground anchor straps from the grey bag.
10. Extend each to its full length.
11. Attach one end of each strap to one of the 20 ground anchors along the outside of the longer sides of the template and two straps at each endwall ground anchor.
12. Lay each one flat and pointing away from the template.

d. Template Removal

After all 20 ground anchors are set, you should remove the template in the following procedure.

1. Remove the blue snaps from the blue rings and attach to the closest corner ring. You will have a large rectangle with two diagonals.
2. Remove the yellow snaps from the central ring and attach to the appropriate red snap on the side cables. The yellow snap is attached to the second red ring to lay the cable flat and make rewinding easier.
3. After each yellow snap is connected to its appropriate red ring, you have a rectangle of cables to remove.
4. Begin by disconnecting the black snap from the black ring. Attach the black snap to the layout template holder, and begin winding the cables evenly and without kinks. Walk toward the closest corner (silver ring #4) and lift out the tent pin. Now begin to wind the cable toward the next corner (silver ring #3), proceed to the next corner (silver ring #2), pull up the tent pin and wind toward the initial black ring. Upon reaching the final black ring disconnect it and attach it to the layout template holder.
5. Place the layout template and all tent pins removed back in the erection kit.

e. Cover Layout and Section Alignment

There are six section covers included with the THE. There are three leaning arch covers, two intermediate arch covers and one endwall section with two endwalls in it.

It is important that the covers are placed in their proper sequence and along the outside of the ground anchors. The proper procedure is as follows:

1. Carry the endwall cover to the inside of the closest endwall ground anchors.
2. The three leaning arch covers are each placed in the 15 ft spaces between the grey ground anchor straps and next to the line made by their ends.
3. The two intermediate covers are placed next to the middle of the group of three anchor straps and in line with the other covers.

NOTE: FIGURE 8 SHOWS COVER LAYOUT.

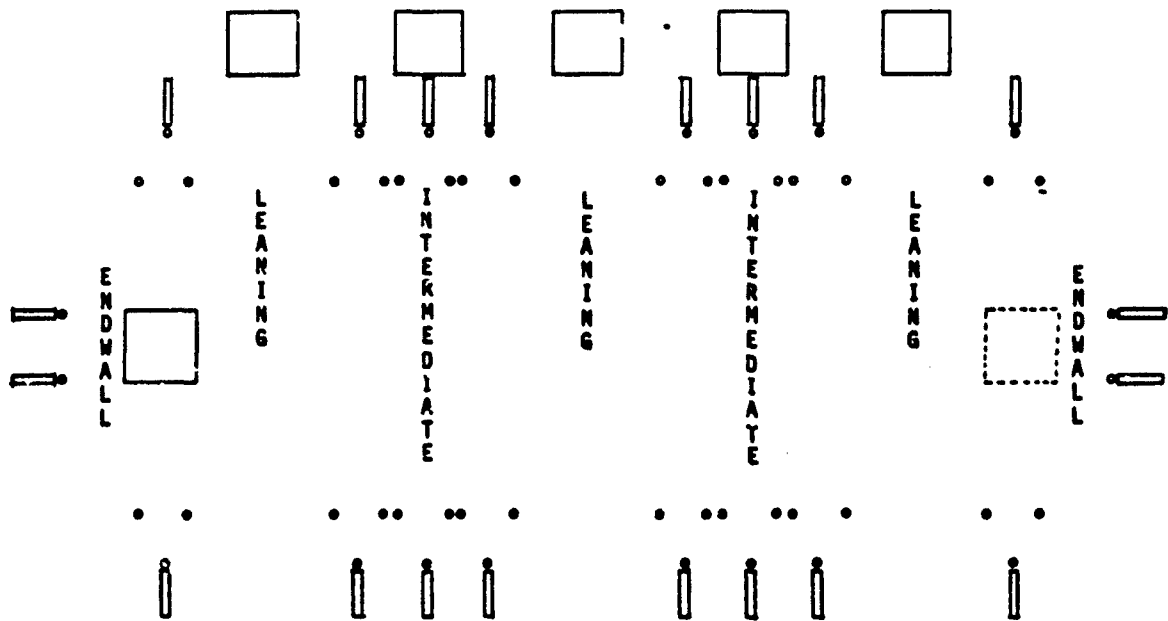

Figure 8. Section cover layout diagram

### Endwall Sections (2)

The endwalls are laid out in the following sequence:

1. Unstrap the large green and the small black straps and open endwall cover holding the two endwalls.
2. Take one endwall from the top and carry it to the other end of the ground anchor placement and six ft inside the endwall ground anchor.
3. Take the cover to the side. Orient the endwall so that it may be rolled away from the center of the shelter and over the endwall ground anchors.
4. Men on both sides should hold the section and slowly spread out the section.

NOTE: THE DARK GREEN SIDE SHOULD BE UP AND THE SECTION SHOULD LOOK LIKE FIGURE 9.

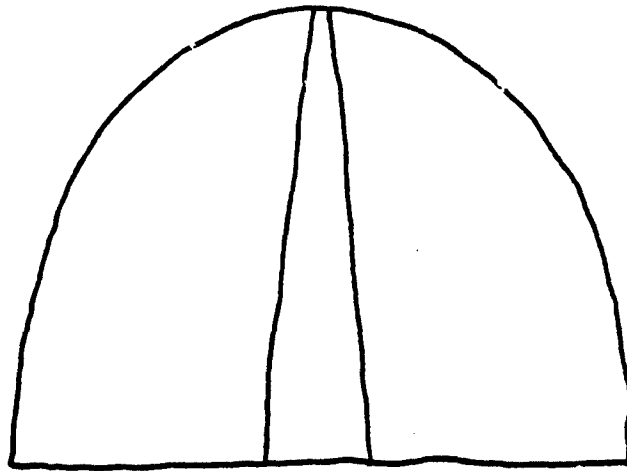

Figure 9. Endwall section

### Intermediate Arch Sections (2)

The intermediate arch section should be laid out in the following sequence:

1. Unstrap the large green and the small black straps from the intermediate arch cover.
2. Remove the section and place it next to the ground anchors.
3. Take the cover and place it in a pile to the side.
4. Orient the section so that it may be rolled towards the ground anchors on the other side and unroll it.
5. Return to the side; locate the base of the arch tubes and the green arch base straps.

6. Two men should each grab one of the green base straps and one on each side walk the section to unfold it towards the ground anchors on the other side.
7. Remain on each side and spread out the section until it lays flat.

**CAUTION:** DO NOT STEP ON THE FABRIC.

**NOTE:** THE DARK GREEN SIDE SHOULD BE UP AND THE SECTION SHOULD LOOK LIKE FIGURE 10.

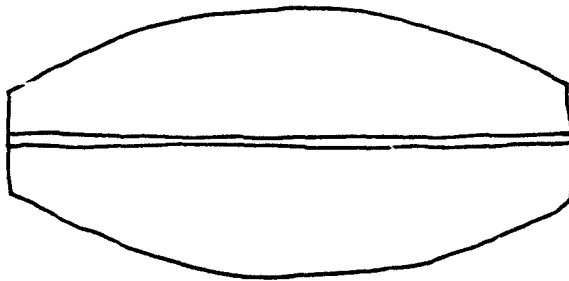

Figure 10. Intermediate arch

### Leaning Arch Sections (3)

The leaning arch sections are unfolded in the following sequence:

1. Unstrap the large green and the small black strap and open the leaning arch section cover.
2. Remove the section and place it on the outside of the cover away from the ground anchor.
3. Place all of the covers in a pile off to the side.
4. Orient the section so that it may be unrolled towards the ground anchors on the other side and unroll it.
5. Locate the base strap of each of the top arch tubes. One man should hold the green arch base strap of the tube on each side and walk across to the ground anchors on the other side until the section is fully extended.
6. Spread out the sections so that they lie flat.

**NOTE:** THE DARK GREEN SIDE SHOULD BE UP AND THE SECTION SHOULD LOOK LIKE FIGURE 11.

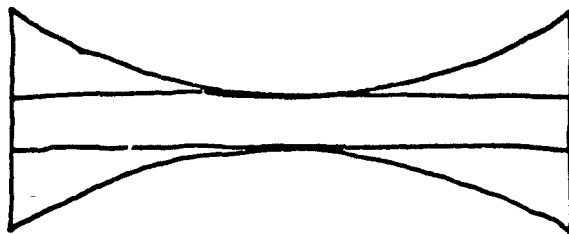

Figure 11. Leaning arch



Figure 12. Arrows at center of section



Figure 13. Kneel in between the sections and next to the center arrows

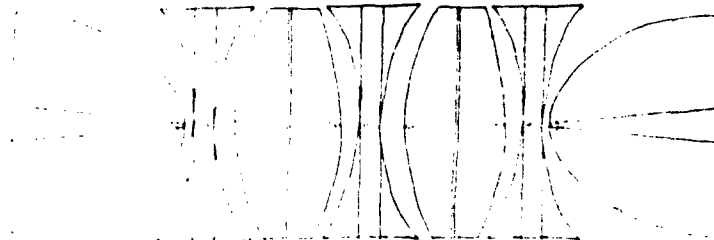

Figure 14. Layout all of the section and align arrows

The next step is to align the centers of the arch and endwall sections. In the center of each section is a large yellow arrow (Figure 12). The arrows printed on each section should be aligned with the section next to it and the section should again be fully spread out. After the sections are aligned and fully spread out the sections will look like Figure 13.

The section are now ready to be becket laced together.

One soldier should be placed in between each section and next to the yellow arrows, at the center (Figure 14). The lacing procedure begins at the middle of the section and progresses outwards towards the ends. There will be five tie-off points on each half of each assembly and a final tie-off point at the end.

NOTE: WHEN BECKETING, STAND IN BETWEEN THE SECTIONS. BE CAREFUL NOT TO STEP ON THE FABRIC.



Figure 15. Insert lace through grommet

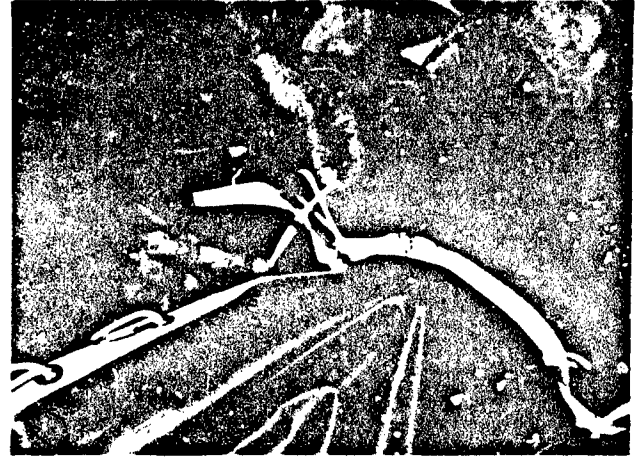

Figure 16. Insert lace through loop in lace before

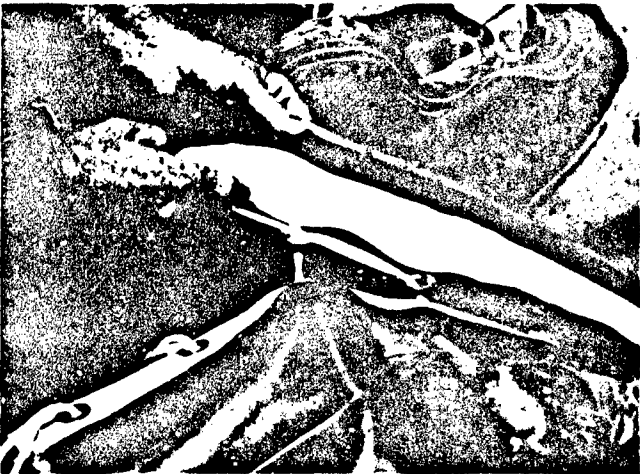

Figure 17. Pull tight

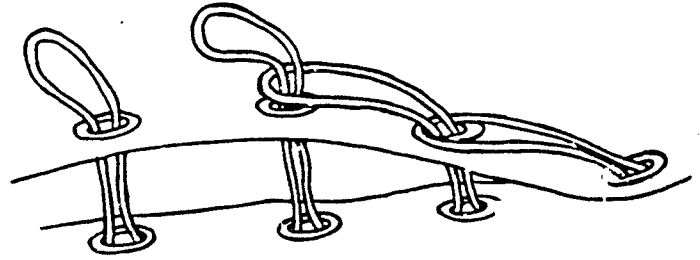

Figure 18. Becket lacing procedure

f. Lacing Procedures (Becketing)

Becket lacing is the method used to connect and secure the enclosure sections together. The lacing is accomplished in the following procedures:

1. Match the breaks in the reinforced webbing starting at the center of the section next to the yellow arrows. Insert the first and second laces through the first and second grommets. (See Figure 15.)
2. Insert the second lace up through the opening in the first lace. (See Figure 16.)
3. Pull the second lace taut. (See Figure 17.) Insert the third lace through the grommet and through the loop in the second lace. Pull this taut. This is the becketing procedure. (See Figure 18.)

**NOTE: BE SURE TO CLOSE THE HOOK AND PILE FLAP OVER THE LACES AS YOU GO. THIS WILL HELP PREVENT RAIN PENETRATION AND ENSURE BLACKOUT PROTECTION.**



Figure 19. Place red loop through red grommet



Figure 20. Insert red loop through loop of lace before it



Figure 21. Pull back towards last lace



Figure 22. Insert red lace through loop of last lace

4. Continue becketing until you have reached the red grommet and the long red becket loop. (see Figure 19.) This is the tie-off point.
5. As with the other becket laces, place the red lace through the red grommet.

NOTE: ALL LACES AND ALL GROMMETS SHOULD BE USED, NONE SHOULD BE SKIPPED. THE RED LOOP SHOULD ALWAYS MATCH UP WITH THE RED GROMMET.

6. Insert the red lace through the loop in the previous lace (Figure 20).
7. Insert the lace after the red one through its grommet (Figure 21).
8. Insert the red lace through the loop of lace after it (Figure 22).



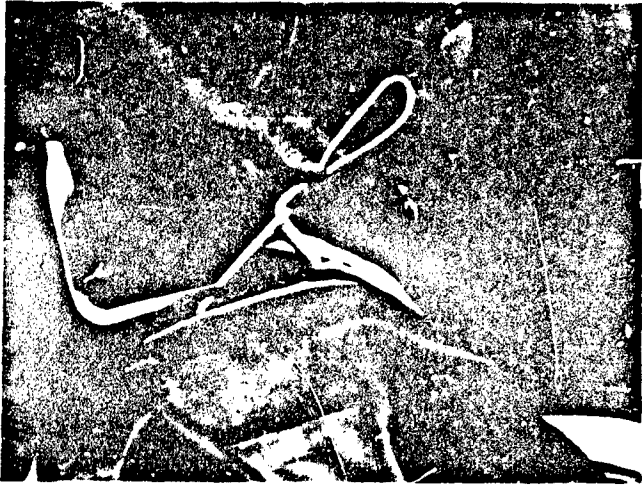

Figure 23. Pull back towards the first lace

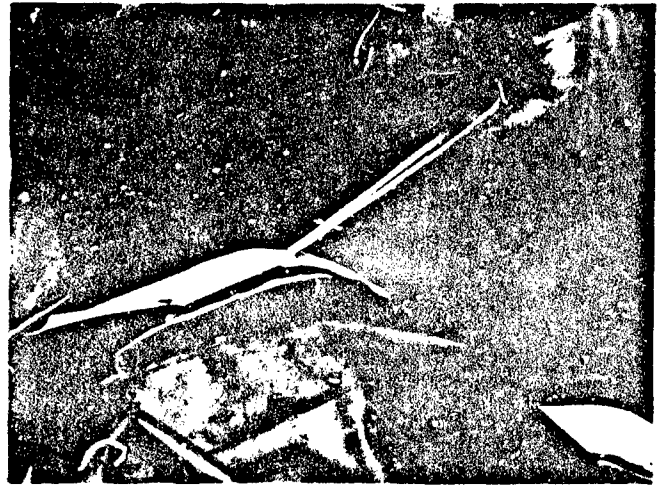

Figure 24. Pull taut



Figure 25. Slide red lace under first lace

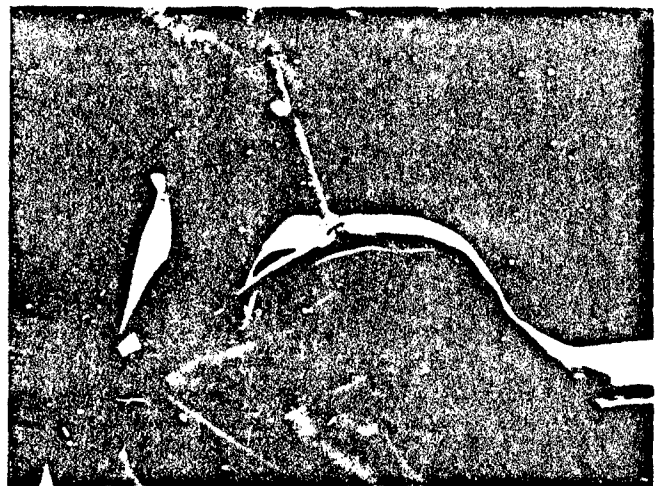

Figure 26. Tie off with half hitch knot

9. Pull the red longer lace back towards the first lace (Figure 23) and pull taut (Figure 24).
10. Slip the red lace underneath the first lace (Figure 25) and tie off with a half-hitch knot (Figure 26). Every 20 laces there is a tie-off point. After tieing-off, begin the becketing procedure again. Continue this process until you reach base of the arch tube and the last tie-off point.

NOTE: REMEMBER TO COVER THE LOOPS WITH HOOK AND PILE CONTINUOUSLY WHILE BECKETING.

After completely lacing and tying off, go around to the other side of the shelter and spread out this section to expose all laces and grommets. Again starting at the center and working towards the outside, complete the becketing procedure. Using all eight men along the side of the shelter, position one at the base of each arch tube. Hold the green arch base anchor straps and walk the side in to the inside of the grey ground anchor straps already connected to the outside ground anchors. Turn the edge of the shelter up to expose the underside of the weather barrier and the base of the arch tubes.

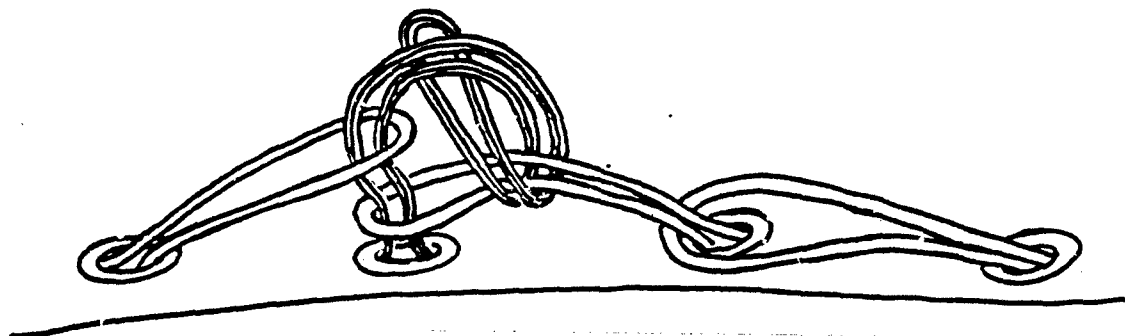

Figure 27. Tie off procedure

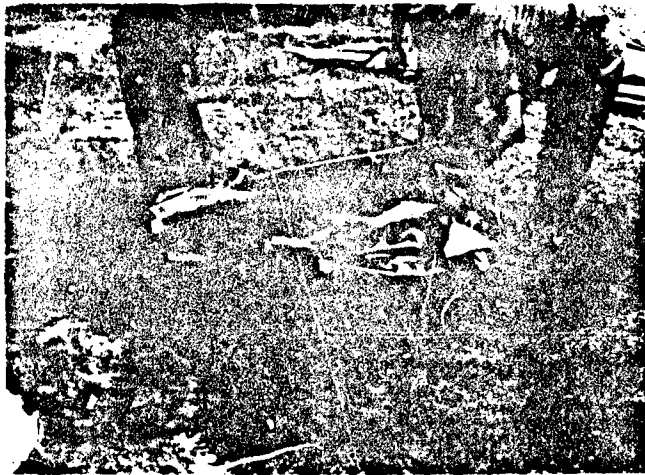

Figure 28. Unwrap and find the capped end

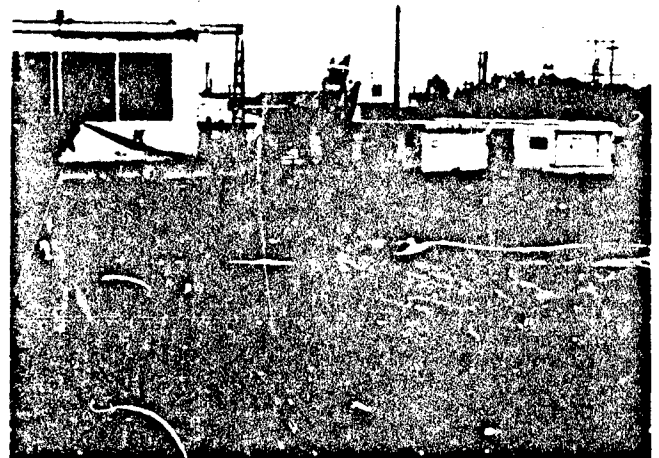

Figure 29. Walk the manifold around the sides of the shelter

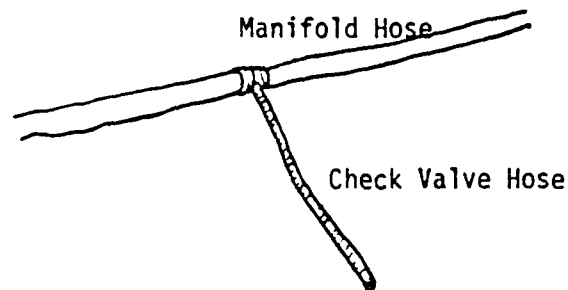

Figure 30. Manifold and check valve hose

g. Manifold Layout and Initial Anchoring

Next open the cover with the inflation manifolds and find the capped end (Figure 28). With the capped end first, walk the manifold to position along each side (Figure 29). The manifold check valve hoses should match up with the outside of the base of the arch tubes (Figure 30). You must ensure that the manifold hoses are not twisted.

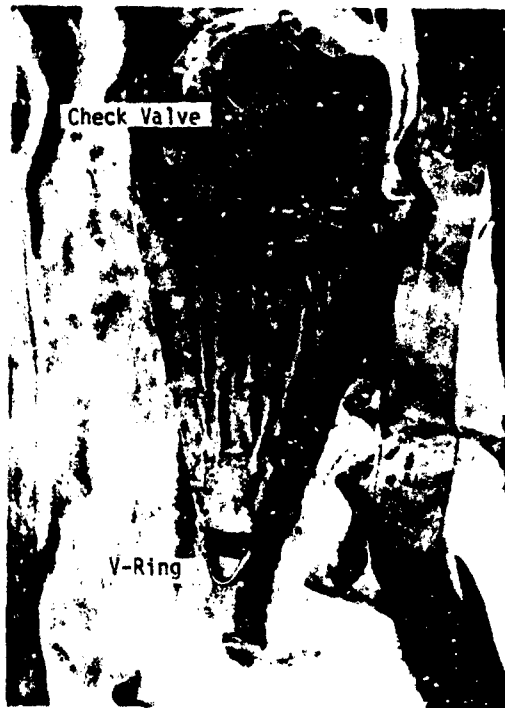

Figure 31. Arch tube check valve

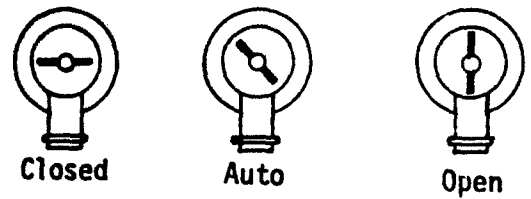

Figure 32. Check valve position

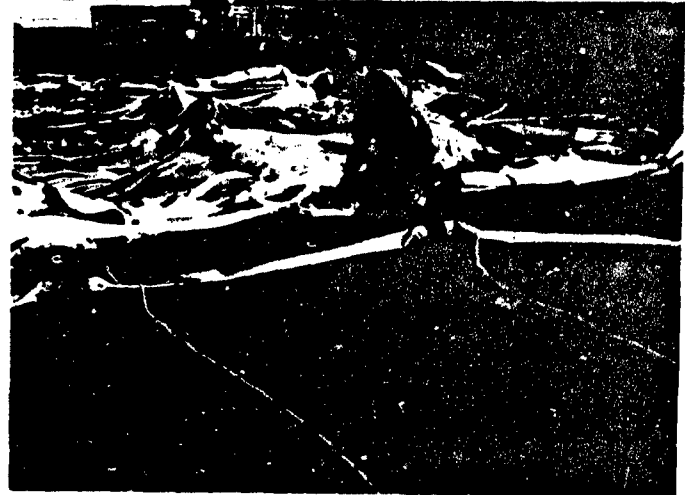

Figure 33. Check connection to be sure they are not twisted

Manifold Layout and Initial Anchoring (Cont.)

Locate the check valve (Figure 31). Ensure the valve is in the "Open" position (Figure 32). Take the check valve hose attached to the manifold and connect it to the check valve with smaller hose clamp and nut driver located in the erection kit. Bring the weather barrier back over the arch tube bases. Walk around the shelter looking at all of the connections to ensure that they are correctly placed (Figure 33).



Figure 34. Connect manifold to the manifold extension

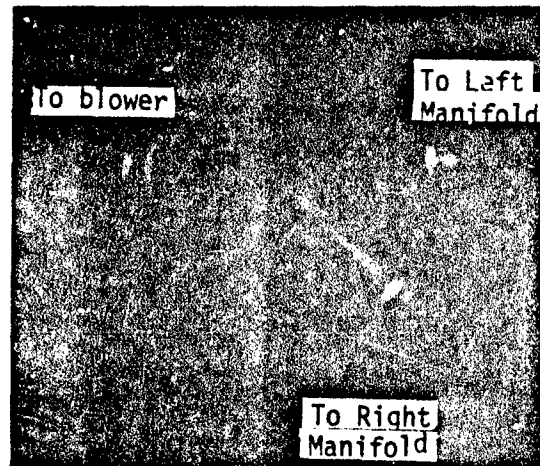

Figure 35. Manifold junction



Figure 36. Secure the manifold extension to the junction

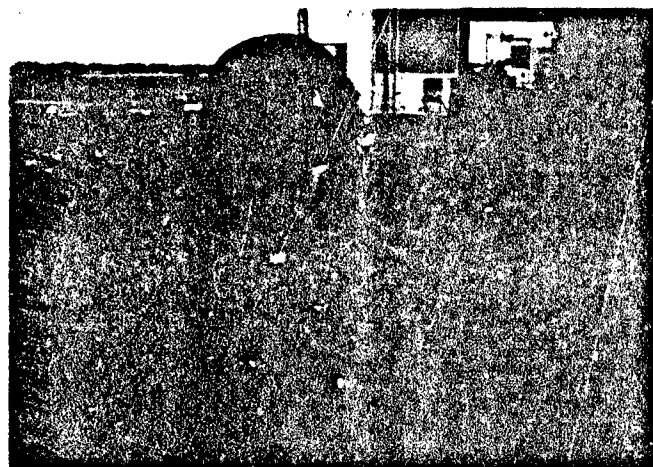

Figure 37. Connect the six foot extension to the blower

1. Attach the two blower manifold extensions (18 ft long) to the manifold hose on both sides (Figure 34).
2. Each extension is then attached to the manifold junction (Figures 35 and 36). See overall Figure 38.
3. Connect the manifold junction and the six ft manifold extension using the hose clamp and nut driver provided in the kit.
4. Hook up the six ft extension to the blower (Figure 37).

NOTE: ALL OF THESE CONNECTIONS WILL BE MADE WITH THE LARGER HOSE CLAMP AND NUT DRIVER LOCATED IN THEIR ERECTION KIT. THE MANIFOLD ASSEMBLY WHEN COMPLETE WILL LOOK LIKE FIGURE 38.

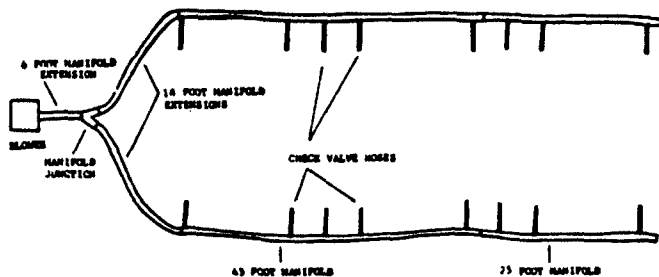

Figure 38. Manifold layout diagram

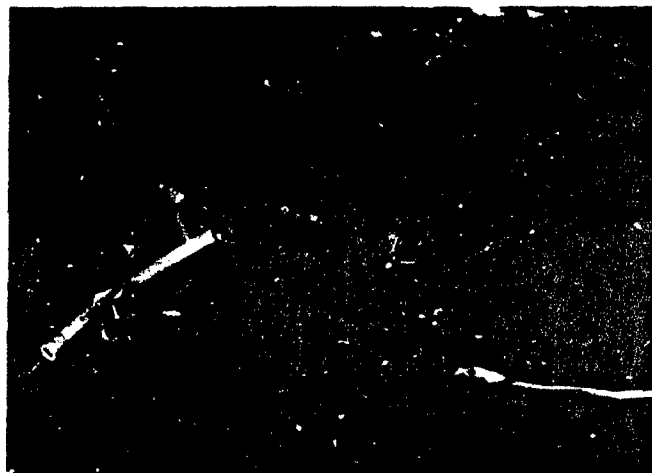

Figure 39. Attach anchor strap to V-ring of arch tube

Locate the outside V-rings located about 2 ft up on the outside of the arch tube. Locate grey ground anchor strap connected to the outside ground anchors and attach it to the V-ring. (Figure 39). Now all 16 of the arch tube bases should have grey ground anchor straps on the outside and one check valve hose secured to the check valve and in the open position. Again check manifold for kinks and binds.



Figure 40. Connect snap hook of endwall cables to V-ring on endwall arch



Figure 41. Full zipper down one foot

Attach the endwall cables to the endwall arch using the snap hook. Make sure the zipper is pulled down one foot. Walk the zipper lanyards outward to insure they are untangled. (Figures 40 and 41). Attach the endwall grey ground anchor straps to the ground anchor cable and the endwall cables.

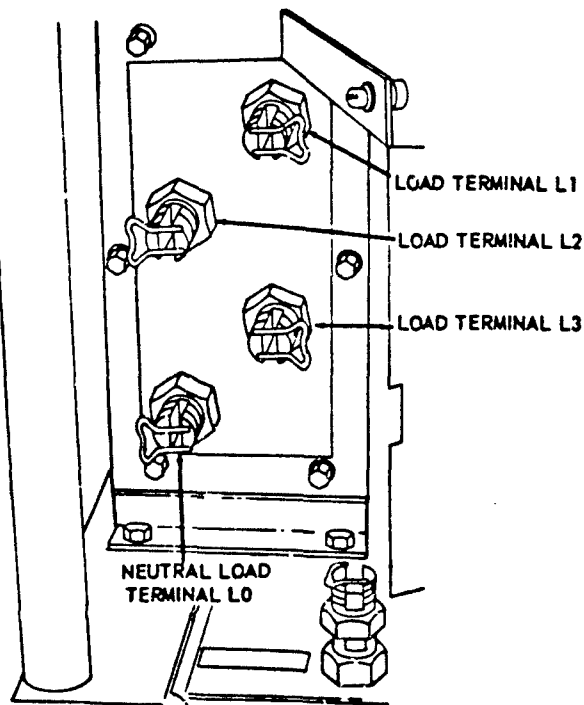

Figure 42. Generator terminals

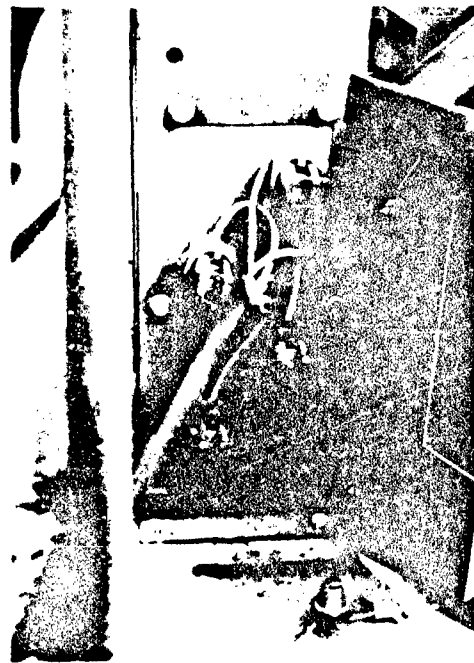

Figure 43. Blower cable connected to generator

#### h. Connection of Blower to Generator

Power is provided to the blower by a 10 KW generator. The 5 hp blower uses 4 colored wires, a green ground, red, black, and white.

NOTE: IT IS IMPORTANT THAT THE GREEN GROUND WIRE BE CONNECTED FIRST.

1. Connect the green ground wire to the terminal marked L0 (Figure 42).
2. Connect the red wire to the terminal marked L1.
3. Connect the black wire to the terminal marked L2.
4. The white wire is connected to the terminal marked L3 (Figure 43).

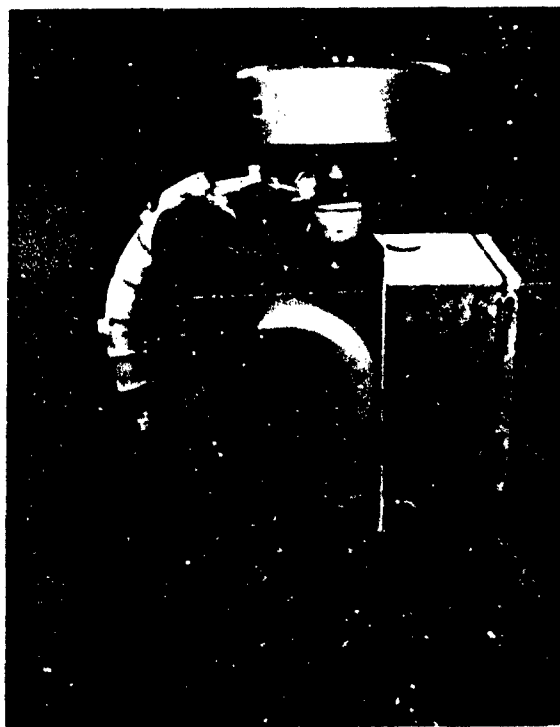

Figure 44. Blower



Figure 45. Observe rotation while turning on

Because the generator is a three phase system, improper rotation of the blower may occur. When starting the blower it is essential that rotation follows the direction of the yellow arrow printed on the blower housing (Figure 44). The proper procedure is to turn on the blower, and immediately turn off. Observe the motor and ensure that its rotation is in the same direction as the yellow arrow (Figure 45).

**NOTE: IF IMPROPER ROTATION OCCURS, YOU MUST INTERCHANGE THE RED AND BLACK WIRES BEFORE CONTINUING BLOWER OPERATION. IMPROPER ROTATION OF THE BLOWER WILL CAUSE OVERHEATING AND FAILURE OF THE BLOWER MOTOR.**





Figure 46. Help the arch tubes to inflate

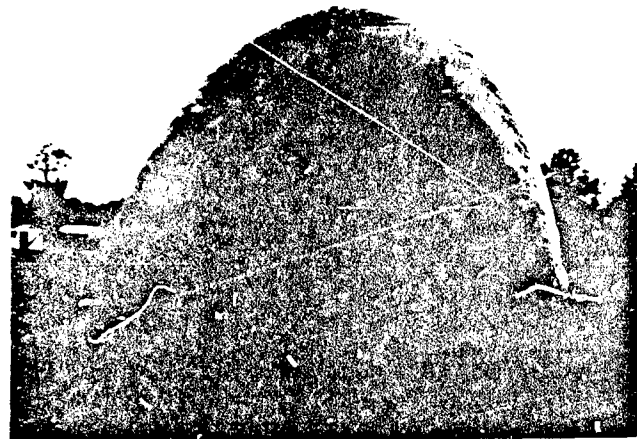

Figure 47. Shelter ready for tie down

#### 1. Inflation Instructions

Depress the blower "on" button to initiate inflation of the arches. Once the blower has started the tubes will slowly start to inflate. The arch tubes should be helped up by all personnel present. (Figure 46). Pushing the tubes up helps relieve the pressure on the blower and speeds up erection time.

It is also important that this shelter be erected without kinking or binding. While assisting the inflation each soldier should again check the manifolds to be sure of proper position. Grab the arch tube base straps and pull the arch tube base to within the outside ground anchors. After its enclosure is erect (Figure 47) enter the shelter and set each of the 16 check valves to the automatic position (Figure 32) then turn off blower and generator.

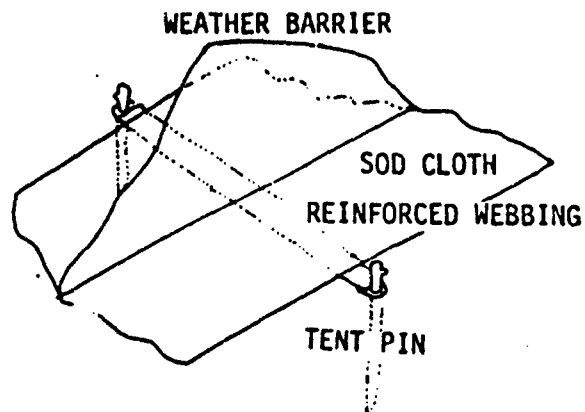

Figure 48. Anchoring of arch tube base

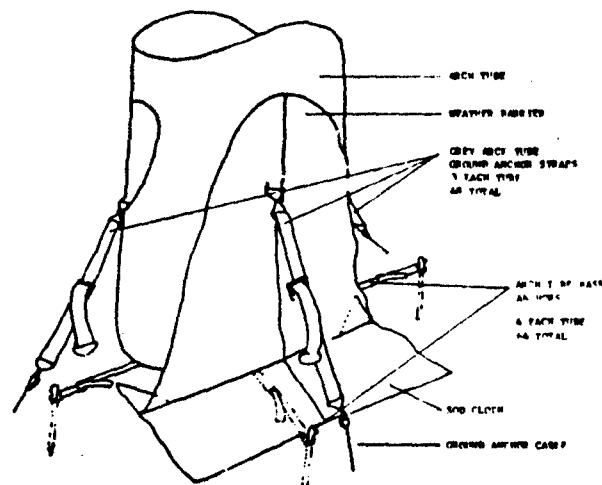

Figure 49. Sod cloth anchoring

i. Tie Down Procedure

1. Place one person on the outside and one on the inside.
2. Each person should locate the green base anchor straps under the bottom of each arch tube. (Figure 48).
3. While both people are holding these straps, each arch tube should be moved to within one ft and in line with the outside ground anchor.
4. After the arch tubes are aligned, secure the green straps with the tent pins included with the erection kit.
5. Adjust the straps until snug.
6. Attach one end of the grey straps from the erection kit to each of the V-rings on the inside of the arch tube and adjust to its full length.
7. Attach the other end of the strap to the ground anchor on each side.
8. Tighten the strap until snug.
9. Walk around the shelter and tighten each strap until snug.
10. After the arch tubes are completely secured, turn on the blower and inflate for five minutes.
11. Turn the check valve to the close position.
12. Disconnect the check valve hoses and pull them out from under the sod cloth.
13. Disconnect the manifold sections and return them to the manifold cover.
14. Secure sod cloth on both the inside and outside using 2-1/2 lb hammer and red tent pins included with the THE. (Figure 48).



Figure 50.

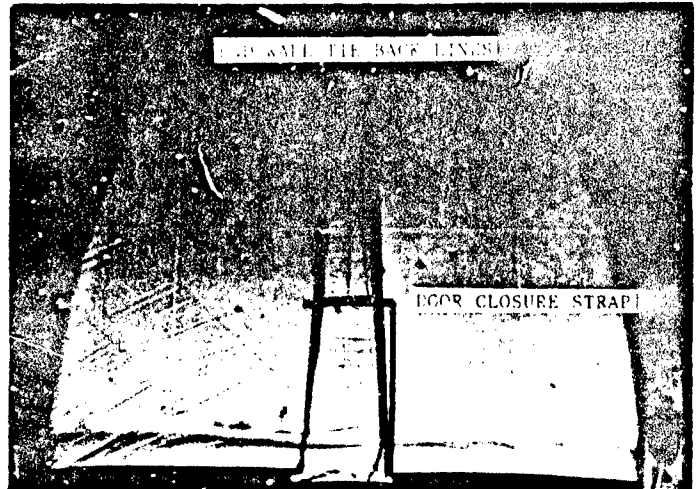

Figure 51.

#### k. Endwall Door Operation

To open Endwall Door.

1. Raise zippers to within one ft of the top. This is done by pulling one side of the loop of line hanging down in at the center.
2. Disconnect the grey ground anchor strap from the endwall cables.
3. Disconnect the door closure strap.
4. Two soldiers should slowly roll the endwall fabric to within three ft of the sides.
5. While one soldier holds the fabric, the other should pull the endwall tie-back lines taut and tie them to the D-ring for the inside ground anchor straps (Figure 50).
6. Pull the tie-back strap from the inside of the endwall fabric at the six ft level around the rolled up endwall fabric and attach it to the ring on the outside.

To Make a Personnel Door.

1. Attach the door closure strap.
2. Unzip both zippers to one fit above the door closure strap. (Figure 51).
3. Pull back the overlapping fabric to either side and tie it back with the attached webbing.

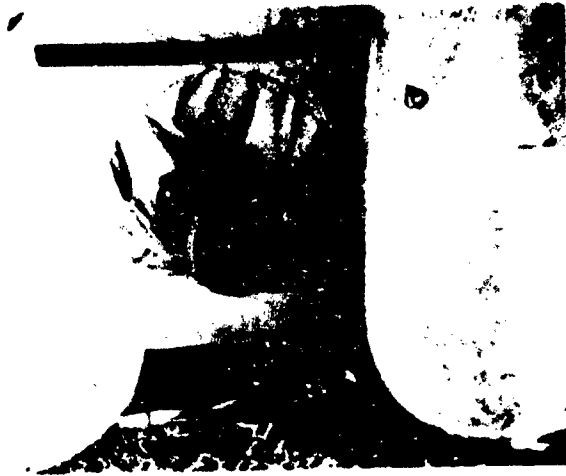

Figure 52. Environmental control duct entering shelter (inside)



Figure 53. Environmental control duct entering shelter (outside)



Figure 54. Emergency exit (inside)



Figure 55. Emergency exit (outside)

#### Emergency Exits And Environmental Control

The standard 61 ft THE has four emergency exits, two on each side. The escape had a weather barrier fabric tube fastened with velcro to provide blackout protection and to keep out the elements. To exit, simply pull down the flap and jump through.

Two of these emergency exits may be used as heater ducts. To close around ducts, simply fasten velcro to provide a tight seal.

## 1. Shelter Extension

Extending the THE may be done easily using parts from another shelter. The parts needed to make a 106 ft shelter include: One leaning arch section, one intermediate arch section, two 25-ft manifold extensions, an extension layout template, extra ground anchors, tent pins and ground anchor straps. The extension may be used anytime that a longer space may be necessary and may be used whether the shelter is already erected or not. If the shelter is erected it must be deflated so that it is at ground level to lace together. If the extension is to be added to the standard 81 ft THE, it should be thought out from the very beginning, users noting this extra length of the shelter and what effect that will have on the site selection and shelter orientation. If the shelter is initially erected in its extended length, then the extension layout template should be laid out at the same time as the standard layout template. Continue through normal erection procedure.

In order to extend the THE, it must first be lowered.

1. Remove all objects from within the shelter.
2. Open the endwall zipper completely.
3. Remove a slight amount of air in order to make the ground anchors slack.
4. Carry the two manifolds, capped end next to the last leaning arch and the end from which you are going to extend.
5. Ensure that the check valve tubes match up approximately with the arch tubes.
6. Tuck the check valve hoses under the weather barrier making sure that the manifold itself remains outside of the ground anchors.
7. Go inside and using the hose clamp and nut driver provided in the erection kit, secure all of the check valve hoses to the check valves.
8. Again ensure that there is nothing left inside the shelter.
9. Go from tube to tube inside the shelter and place them all in check valve open position, allowing the shelter to fall.
10. Walk around the outside of the THE to untangle the manifolds and ensure the air is emptying from the tubes evenly and easily.

To remove the endwall:

After the shelter has completely dropped, walk to the center of the endwall that will be removed to add the new section. Cables at the center of the endwall are connected to grey ground anchor straps and these to ground anchors.

11. Disconnect the grey ground anchor straps and place them in the erection kit.
12. Use bolt cutter to snip off the ground anchor cables below ground level.
13. Now using a soldier on either side of the shelter, remove the endwall by opening the weather flap, untying the tie-off and disconnecting the becket laces.
14. After the endwall assembly is folded, place it off to the side. The THE may be extended in increments of 25 ft (one 18 ft leaning arch assembly and one 7 ft intermediate arch assembly). These two units must be used together and the shelter is extended only in 25 ft increments.
15. Disconnect the arch tube base pins and the two inside ground anchor straps from the end leaning arch tubes.

Layout procedure for extension ground anchor template (see Figure 54):

1. Remove the extension ground anchor template from the erection kit.
2. Walk over to one of the leaning arch tubes on the end of the shelter where the endwall was removed. There should be only one outside ground anchor strap holding each arch tube base in place.
3. Gently push the arch tube and the weather barrier fabric back towards the rest of the shelter in order to have a clean space in which to layout the template. Untie the first loop of the layout template which is black, and using a tent pin, secure it to within three inches of the place where only the ground anchor cable enters the ground. Hammer the pin in several inches. It should not stress the ring or cut the cables.
4. Start unwinding the cables from the template frame while walking in the direction in which the shelter is going to be extended. The first yellow ring is the first corner.
5. This ring should be held by a soldier while the template continues to be laid out.
6. Now start walking across in front of the shelter until reaching the second yellow ring and the second place the cable template will turn a corner.
7. Have a soldier stand and hold this ring while the layout process is finished.

Yellow Tape For Ground Anchor Placement

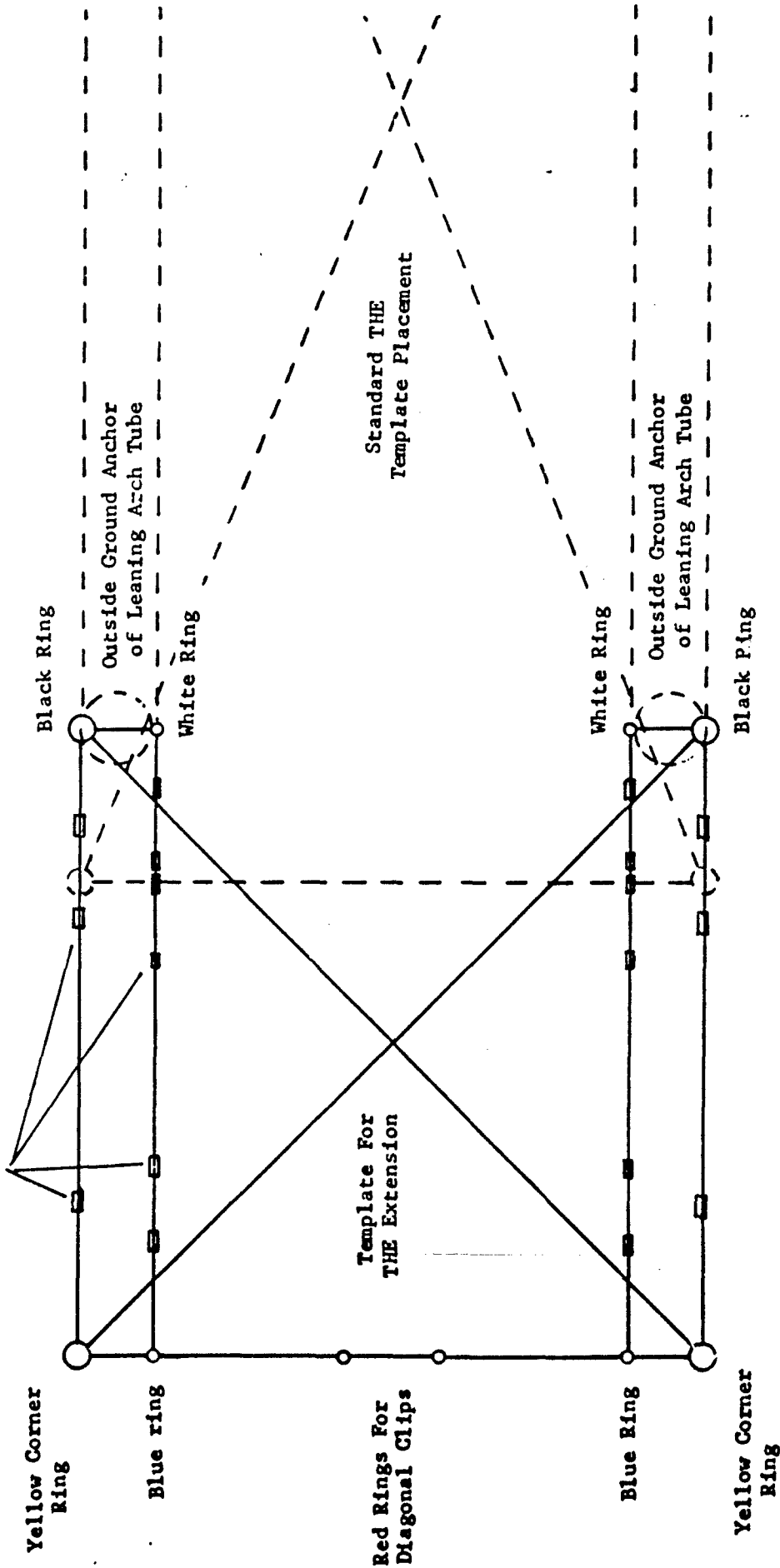

Figure 56. Extension ground anchor layout cable

8. While continuing to unwind the cable walk back towards the THE. Facing the other side of the last leaning arch ring you will reach the second black ring. This black ring should be pinned, again using an aluminum tent stake from the erection kit, within two inches of the ground anchor cable that holds the outside of leaning arch tube.

NOTE: YOU SHOULD NOW HAVE ONE BLACK RING PINNED ON EITHER SIDE OF THE LEANING ARCH TUBE AND TWO YELLOW RINGS BEING HELD BY SOLDIERS AT THE OTHER END OF THE TEMPLATE. THESE FOUR POINTS WILL MAKE AN APPROXIMATE SQUARE. TO BE SURE THAT THE CABLES ARE CORRECTLY PLACED WE MUST ATTACH DIAGONAL CABLES BETWEEN THE TWO YELLOW RINGS AND THE TWO BLACK ONES.

9. Remove one red snap from the red rings on the far end of the template.
10. While carrying the snap, drag the cable towards the yellow ring furthest away to create a diagonal across the square template.
11. Attach the red snap to the yellow ring, pull taut and peg in place.
12. Disconnect the other red snap from the red ring, walk to the yellow ring furthest away and connect the red snap to the yellow ring.
13. Pull the cables taut and gently peg the ring into the ground. The diagonal cables connect the yellow and black rings. You now have a perfect square and are ready for the final procedure. The final stage in the template layout procedure is to anchor the two white rings. The white rings (one on either side) are located in the middle of the cable attached to both the blue and black loops.
14. Locate the white ring, which is four feet from the black ring, and pull it taut towards the center of the template. The cable will go across to the area where the arch tube base was. Pin both white rings. The template should now be arranged like Figure 54. Note that if the extension template and the standard template are laid out at the same time, there is a 7 ft overlap. This is because the end of the extension template must match up with the last leaning arch tube ground anchor and the endwall extends out seven feet. Using the instruction outlined on page 8, Anchor Installation, install a ground anchor at each of the places marked with the yellow tape on the layout template cables. When extending the shelter 25 ft, there will be 20 ground anchors to be placed.

After all of the anchors are placed and have been set, remove the template in the reverse order of placement:

1. Pull the pins holding the white rings and place them back in the erection kit.



2. Disconnect the red snaps holding the diagonal cable to the yellow rings and reconnect to the red ring furthest away. Do this on both sides.
3. Remove the cable to plate frame from the erection kit. Pull up one of the tent pins holding a white ring to the ground. Pull up the tent pin holding the black ring right next to it and tie this ring to the layout template frame.
4. Slowly wind all three cables on the frame evenly and without kinks. You will pin the white ring and finally come to the first yellow ring.
5. Pull up the tent pin holding the first yellow ring to the ground and continue winding the cable.
6. Continue winding the cable and progress to the second yellow ring, pull up the ring and proceed, always ensuring that all three cables are wound as evenly as one.
7. Before reaching the second black ring remove the pin and reattach the black ring to the template. Pick up all tent pins remaining around the site and with the template frame place them back in the erection kit.

## Section II. Striking Procedures

Before striking the THE, walk around during daylight if possible to check for any tears, loose seams, or abrasions in the weather barrier fabric. Also walk around and check all of the arch tubes to be sure they are firm and have not lost any air. If there are any problems, look at the maintenance procedures in this manual or refer to the maintenance allocation chart. After checking and ensuring there is no damage to the shelter, it may be struck using the following procedures.

1. Remove all items from inside the shelter.
2. Unzip the endwall zippers to within one foot of the top.
3. Disconnect black endwall barrier straps, if used from both endwalls.
4. Remove the two grey tie-down straps from each endwall.
5. Disconnect the door closure strap from each endwall.
6. Untie the 16 high wind lines from the ground anchor cables if used.
7. Pull up the tent pins holding the green arch base anchor straps at each arch tube.

8. Pull up the tent pins holding the sod cloth inside and outside if used.

NOTE: THE PINS ARE EASIER TO REMOVE IF THEY ARE HIT LIGHTLY ON EACH SIDE WITH THE 2-1/2 LB. HAMMER.

10. Again check to be sure that the inside of the shelter is empty.
11. Walk around the inside of the shelter and turn each of the 16 check valves to the open position.
12. Wait for the shelter to fall.
13. Disconnect the black secondary anchor straps from the sides of the shelter.
14. Disconnect the grey outside ground anchor straps at each arch tube.
15. Lift up the edge of the shelter, expose the two inside V-rings on each arch tube.
16. Remove all of the grey ground anchor straps from the ground anchors and return them to the ground anchor strap bag.
17. Pull back the velcro and begin untying the becket lacing.

When the shelter is completely unlaced each section is ready to be folded and packed in the appropriate cover.

NOTE: IT IS IMPORTANT THAT THE SECTION COVERS ARE ARRANGED IN THE PROPER ORDER AND PLACED ALONG ONE SIDE OF THE ENCLOSURE. THE ENDWALL COVER SHOULD BE PLACED NEXT TO THE ENDWALL CABLE GROUND ANCHORS. EACH TYPE OF SECTION HAS A SPECIFIC FOLDING PROCEDURE BEFORE BEING PLACED IN COVER.

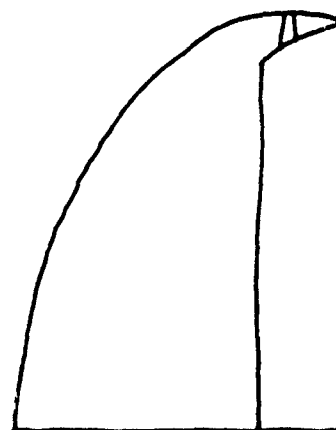
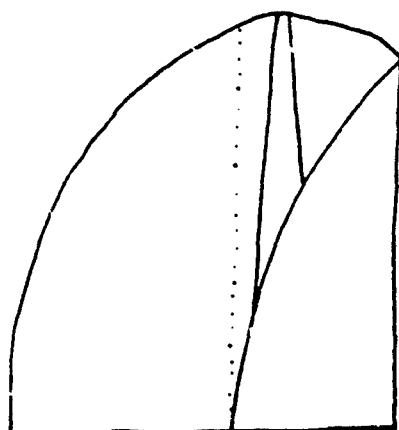
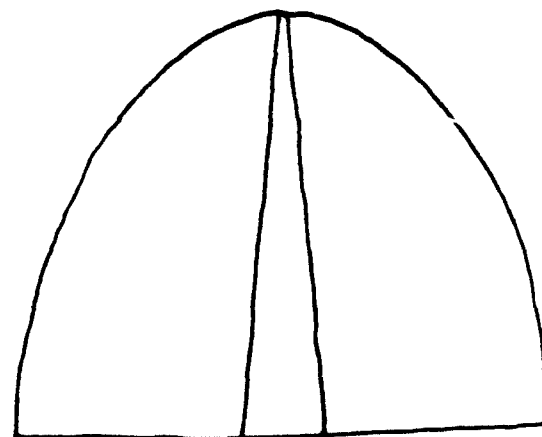
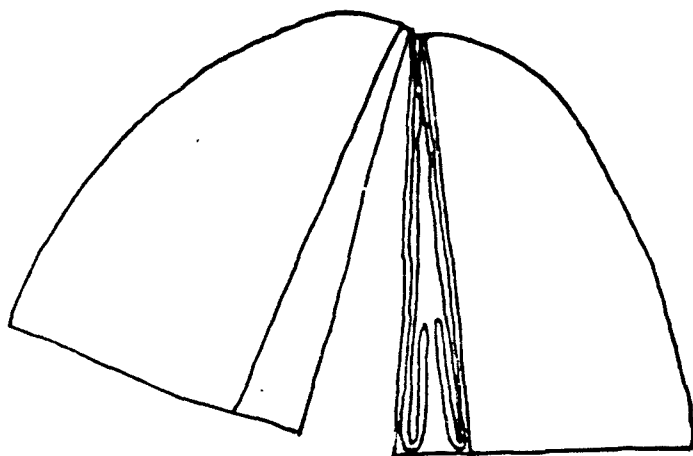

Figures 57-63. Folding endwall

#### Folding Endwall

1. Place soldiers around the outside of the endwall and lay it out flat.
2. Straighten out zipper lines, lay them on the right side door flap and fold them over so they lay completely on the fabric (Figure 57).
3. Pull the left side door over the right to overlap the door and cover the zipper lines (Figure 58).
4. Fold one half of the endwall outer to a vertical line drawn from the endwall cable base to two feet from the top of the zipper (Figure 59).
5. Fold this side over again to the same point (Figure 60).

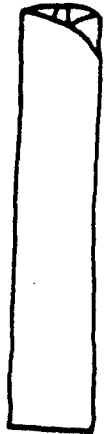
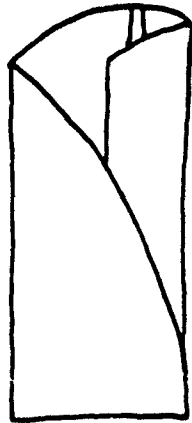

Figures 57-63. Folding endwall

6. Fold over the other side using the fold as a guide (Figure 61).

7. Fold this side over again (Figure 62).

NOTE: THIS SECTION SHOULD NOW BE FOUR FT IN WIDTH.

8. Starting at the bottom, fold up in four sections (Figure 63).

9. When folded completely, lift and place in the correctly labeled cover. Now walk to the opposite end and use the same procedures outlined earlier. Fold up the second endwall and place in the cover on top of the other endwall. Fold the other flaps over the top of this and tighten the smaller black and larger green straps of the cover.

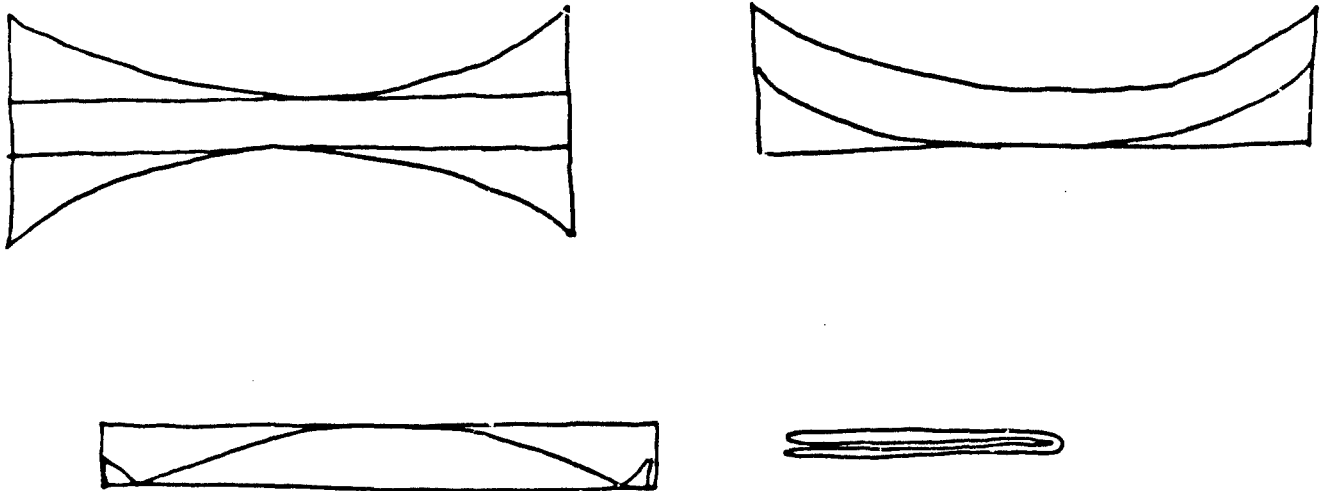

Figures 65-67. Folding leaning arch

Folding the leaning arch section

1. Fully spread out the leaning arch section (Figure 64).
2. Fold over one side until the seam in the fabric is exposed on the light green side (Figure 65).
3. Now fold over the other side until the seam is exposed on that side (Figure 66).

NOTE: THE FOLDED SECTION SHOULD NOW BE ABOUT FOUR FEET IN WIDTH.

4. Two men should hold the green arch tube base straps, one on either side of the folded section and slowly walk it over the top of the section towards the laid out cover (Figure 67).

NOTE: WALK THE SECTION SLOWLY TO ENSURE IT FOLDS OVER THE BOTTOM PART EVENLY.

5. The section will now be folded in half.
6. Find and expose the check valves. They should remain in the open position.
7. Two people should start rolling up the section starting at the fold opposite the arch tube bases.
8. The rolling should be done slowly and smoothly to allow the air to escape through the check valves. Use your knee to smooth out the arch tubes as the sections are rolled. Place weight on and remove all air from the tubes.
9. While the shelter is rolled to the check valves have one man hold the rolled section in place.
10. The second soldier should move to the base of the arch tubes and start the same rolling procedure.
11. The second soldier should roll the base of the arch tube up being careful to squeeze out all of the air until reaching the check valves. Now place all four check valves in the closed position and unroll the base of the arch tube. Both soldiers should then continue rolling the shelter over the check valves and over the base of the arch tubes.

The leaning arch cover should be open and laid open at the end of the rolled section. The rolled section should be lifted and placed in the cover. The cover should be folded over the section and the small black straps put through the D-rings and tightened. The other side should be folded over and the large green straps put through the D-rings and tightened.

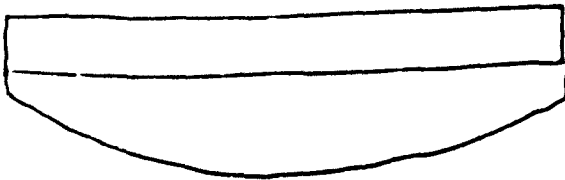
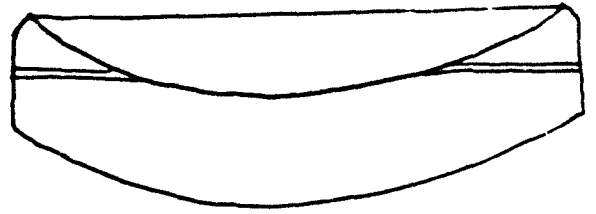
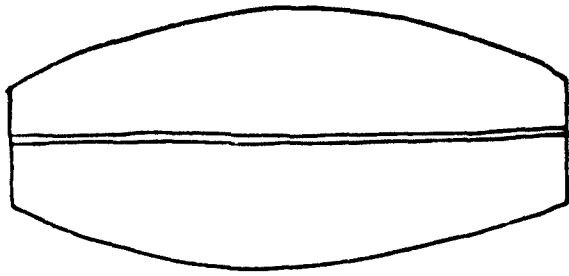

Figures 68-71. Folding intermediate arch

Folding intermediate arch section

1. Lay the intermediate arch section out flat (see Figure 68).
2. Fold one side over to two ft past the center seam (see Figure 69).
3. Fold this side over again to the same point past the central seam (see Figure 70).
4. Fold the other side over to the last fold (see Figure 71).
5. Fold this side the second time.

**NOTE: THE FOLDED SECTION SHOULD NOW BE FOUR FT IN WIDTH.**

6. Two soldiers should hold the green arch tube base straps, stand on either side of the folded section and slowly walk the base over the top of the section towards the laid out cover.

**NOTE: OTHER SOLDIERS SHOULD ASSIST IN ORDER TO MAKE THE SECTION FOLD EVENLY AND NEATLY.**

NOTE: THE SECTION WILL NOW BE FOLDED IN HALF.

7. Find and expose the check valves, they should remain in the open position.
8. Two people should start rolling up the section starting at the fold opposite the arch tube bases.
9. The rolling should be done slowly and smoothly to allow the air to escape through the check valves. Use your knee to smooth out the arch tubes as the section is rolled. Place weight on and remove all air from the tubes.
10. When the shelter is rolled to the check valves, have one soldier hold the rolled section in place.
11. The second soldier should move to the base of the arch tubes and start the same rolling procedures.
12. The second soldier should roll the base of the arch tube being careful to squeeze out all of the air until reaching the check valves; this person should place all four check valves in the closed position and unroll the base of the arch tube. Both soldiers should then continue rolling the shelter over the base of the arch tubes. The intermediate arch cover should be open and laid open at the end of the rolled section.

The rolled section should be lifted and placed in the cover. The cover should be folded over the section and the small black straps put through the D-rings and tightened. The other side should be folded over and the large green strap put through the D-rings and tightened.

### Section III

#### Operation Under Unusual Conditions

General. This section contains the special operating instructions which in addition to those contained in Sections I and II are necessary for the proper function of the tent in extreme cold and wet conditions.

#### Use in adverse climate

##### a. Extreme Cold

1. When selecting a tent site on snow-covered ground prod the surface with a sharp pointed pole to locate any concealed crevices. If the tent site must be located where there are crevices, mark their locations to avoid accidents.



2. When snow is present on the tent site, pack it down level by stamping on it.

3. Frequently use a soft brush or broom to brush the snow from the weather barrier to avoid unnecessary weight being placed on the arches.

b. Wet Climate

1. Always keep tent lines loose enough to prevent the tent pins from being pulled out of the ground when the lines shrink from dampness.

2. Slope the shelter down from each edge of the enclosure floor and hangar door.

3. Dry the enclosure components before packing them.

c. High Wind Condition

When wind above 20 mph is expected, high wind lines on the THE should be anchored. On the standard 81 ft THE there are 16 high wind lines (one on each side of each arch tube). These are permanently connected to the THE and may therefore be secured in a short amount of time, however, it is best to have the added protection of the lines rather than risk damage to the shelter. To secure the high wind lines, install ground anchors 15 ft from the base of the enclosure and in line with the high wind. Install and secure anchor cable to the high wind lines with double half hitch knots. The second stage of the high wind protection is the anchoring of the catenaries around the base of the shelter. Ground anchors are installed through the holes in the sod cloth, the black clips are attached and the straps adjusted. With both highwind systems attached the THE can withstand winds to 50 mph and gusts to 65 mph.

d. Blackout Curtain Installation

1. Remove blackout curtain from fabric bag.
2. Locate side of curtain with shorter hook and pile strip. This side is the top of the blackout curtain.
3. Fasten the top hook and pile strip to the velcro strip located directly below the door closure strap.
4. Fasten the side hook to the pile on one side of the endwall door zipper.
5. Fasten the other side of the curtain with the strip located on the blackout curtain and the slings on the endwall.
6. Secure the bottom of the blackout curtain with tent pins provided in the erection kit.

## CHAPTER 3

### OPERATOR'S MAINTENANCE INSTRUCTIONS

#### Section I. Operator's Tools and Equipment

Tools and Equipment. No special tools or equipment are required by operator/crew personnel for maintenance of the Transportable Helicopter Enclosure.

#### Section II. Maintenance Checks and Services

General. To ensure that the THE is ready for use at all times, it must be inspected systematically according to the maintenance services chart. The necessary preventive maintenance services to be performed are listed and described in Chart 3-1. The item numbers indicate the sequence of minimum inspection requirements. Defects discovered during use of the shelter will be repaired immediately if possible or noted for further correction if use can be discontinued. Stop use immediately if a deficiency is noted that would damage the shelter if use were discontinued. All deficiencies and shortcomings will be reported together with the corrective action taken of DA Form 2404 at the earliest opportunity.

Daily Preventive Maintenance Services. This paragraph contains tabulated listings of daily preventive services that must be performed by the operator/crew. The item numbers are listed consecutively and indicate the sequence of minimum inspection requirements. Refer to Checklist 1 for the daily preventive maintenance services.

## CHECKLIST 1

### Daily Maintenance Checks and Services

1. Tiedown straps and high wind lines
  - Check for even tension. fraying or breaks. Tighten or replace guy ropes or straps as required.
2. Tent pins or ground anchors
  - Check for secure installation, reinstall pins or anchors as required (see Figure 49)
3. Arch tube assemblies
  - Check arch tubes for inflation pressure. If partially or completely deflated, repair or report condition to organizational maintenance.
4. Check valves
  - Check valves for leaks by listening. If a valve is leaking, place it in automatic position and press on lever to release a small amount of air. If this fails to clean the valve and stop the leak, report the condition to organizational maintenance.
5. Shelter fabric
  - Check fabric inside and outside of enclosure for wear at seams, broken stitches, holes, weak spots, or other damage to the fabric. Repair or report to organizational maintenance.
6. Attachments
  - Check grommets, zippers, tabs, patches and other attachments for secure installation and repair or report damage to organizational maintenance.

## Section III

### Operator's Maintenance

#### Inspection and serving equipment

Upon receipt, carefully unpack the shipping container and look for any damage that might have occurred to the shelter. Inspect the enclosure after unpacking to ensure all components are present by comparing with Checklist 2.

#### Repair of the arch tube and weather barrier fabric

##### WARNING

ADHESIVES AND SOLVENTS ARE FLAMMABLE. PERFORM WORK IN A WELL VENTILATED AREA AND AWAY FROM HEAT OR OPEN FLAME. DO NOT STORE ADHESIVES OR SOLVENTS IN OR NEAR THE HELICOPTER ENCLOSURE.

After locating a hole in the THE fabric, repair it using the following procedures.

1. Clean the area to be cemented with a clean cloth dampened with toluol solvent to remove dust and foreign material. Do not allow excess solvent to collect at edges of the seams. If area is painted, dampen a clean cloth with toluol solvent and thoroughly clean the area until all paint is removed. If the forest Green side of the fabric (weather barrier) is to be cemented, lightly abrade or rough up the coated surface(s) to the point of dullness using the abrasive pad supplied in the repair kit. Allow the cleaned and abraded surfaces to dry before applying the appropriate adhesive.

The repair of the fabric of the THE is done using the appropriate patching material and two part adhesive. The inflated arch tube fabric is repaired using the two-part adhesive with the red tops and the material marked Arch Tube Fabric. The weather barrier is repaired using the two-part adhesive with the yellow tops and the material marked Weather Barrier Fabric.

Use a one inch diameter patch for holes up to 1/16 inch, use a two inch patch for holes up to 1/4 inch, and a 3-1/4 inch diameter patch for holes up to 1/2 inch diameter. For larger holes, cut a patch that allows a three inch overlap beyond edges of hole.

2. Apply adhesive from the repair kit to both the repair surface and the repair patch. Brush back and forth to work the adhesive into both cemented surfaces.

3. Allow adhesive to dry approximately 15 minutes to a tacky condition before applying next coat.

NOTE: DRYING TIME WILL BE DIFFERENT UNDER COLD OR EXTREMELY HOT WEATHER CONDITIONS. IN DIRECT SUNLIGHT AT 70°F OR HIGHER, THE DRYING TIME REQUIRED BETWEEN COATS OF ADHESIVE IS APPROXIMATELY EIGHT MINUTES.

4. Apply a second even coat of adhesive to both surfaces. Allow the second coat to dry to a tacky condition.
5. Reactive the adhesive surfaces by wiping with a clean cloth wet with toluol solvent. This activates the adhesive and makes surfaces ready for patching.
6. Immediately press the patch adhesive surfaces together, smooth by hand, and use the roller provided in the Repair Kit.

NOTE: BE SURE THE FABRIC IS BACKED UP AGAINST A SMOOTH, HARD SURFACE TO PROVIDE PRESSURE AND MAKE A GOOD BOND. AFTER COMPLETION OF THE CEMENTING PROCEDURE, DUST THE CEMENTED AREA AND ANY EXPOSED ADHESIVE WITH TALC OR POWDERED SOAPSTONE PROVIDED IN THE REPAIR KIT.

NOTE: DO NOT INFLATE THE AIR TUBE OR OTHERWISE STRESS THE CEMENTED AREA FOR AT LEAST 8 HRS. AFTER CEMENTING.

Patching Tears: Trim loose threads from tear with shears provided in repair kit. Cut patch from bulk material large enough to allow a two inch overlap beyond torn edges.

NOTE: WHEN CUTTING OUT PATCHING MATERIAL ROUND OFF ALL CORNERS. CLEAN AND PREPARE PATCH AND SURFACE AROUND TEAR AS DESCRIBED EARLIER.

Repairing Cemented Seams and Repairing Cemented Parts: Repair separated damaged cemented seams and parts as follows:

Using a clean cloth soaked with toluol solvent, dampen cemented parts to separate. Examine separated parts for damage and repair damage by patching or replacement before recementing parts.

Thoroughly clean surfaces to be cemented. Apply adhesive, activate about 10 to 12 inches of adhesive surfaces at a time. Allow activating toluol solvent to evaporate slightly and press together about six to eight inches of seam to ensure that no more seam will be joined at a time than has been activated. Join seams gradually, press surfaces together by moving finger or thumb along seam. Squeeze out all air bubbles from between adhesive surfaces. Roll each six to eight inch section immediately with the roller provided in repair kit. When seam is completely joined, roll length of seam with roller.

Replacing Repair Patches: If a patch loosens at edges, do not remove complete patch for repair, cut off loose or fringed ends and cover old patch with a new larger patch as follows:

Repair a one inch patch with a three inch patch, a two inch patch with a six inch patch, and all larger patches with a patch extending three inches beyond the old seam.

**CHECKLIST 2**  
**COMPONENT LISTING**

Item No.	Nomenclature	No. Required	Part No.
1	Leaning Arch Cover	3	-----
2	Leaning Arch Section	3	D28690-105
3	Intermediate Arch Cover	2	-----
4	Intermediate Arch Section	2	D28767-101
5	Endwall Section Cover	1	-----
6	Endwall Section	2	D28766-101
7	Blower Cover	1	-----
8	Blower	1	D28788
9	Manifold Cover	1	-----
10	Manifold Junction	1	-----
11	43 Ft Manifold Assembly	2	SK5735-101
12	25 Ft Manifold Assembly	2	SK5735-103
13	18 Ft Manifold Assembly	2	SK5735-105
14	6 Ft Manifold Assembly	1	SK5735-107
15	Anchoring and Repair Kit Box Anchoring Kit	1	23D28122
16	Anchor Driving Rod	4	-----
17	Anchor Driving Head	4	5120-00-051-3641
18	Driving Anchor Rod Holder	4	5120-00-134-4725
19	12 Lb Sledge	4	5120-00-900-60951
20	2½ Lb Hammer	2	-----
21	3/8 in Nut Driver	4	-----
22	5/16 in Nut driver	4	-----
23	5 in Hose Clamp (Manifold Assembly)	10	-----

24	2 in Hose Clamp (Check Valve)	20	-----
25	Ground Anchor Layout Template	1	-----
26	Ground Anchor Extension Layout Template Repair Kit	1	-----
27	Weather Barrier Fabric (M11764)		
	20 in X 60 in	20	-----
	3 in Disc	20	-----
	5 in Disc	20	-----
28	Arch Tube Fabric (9M11766)		
	20 in X 60 in	2	-----
	3 in Disc	20	-----
	5 in Disc	20	-----
	3 in X 10 in Tape	2	-----
29	Adhesive, Weather Barrier Fabric, M11055 Style "S" (Yellow Tops)		
	½ pt Can Adhesive	8	-----
	2 oz Bottle Accelerator	8	-----
	(Mix One Bottle With Each Can As Required)		
30	Adhesive, Arch Tube Fabric, M11628 (Red Tops)		
	½ pt Can Adhesive	8	-----
	2 oz Bottle Accelerator	8	-----
	(Mix One Bottle With Each Can As Required)		
31	Oval Sash Brush	4	-----
32	2 in Roller	1	-----
33	Scissor	1	-----
34	Dobie Pad	2	5350-00-192-5047
35	Thread (300 Ft Spool)	1	-----
36	Sewing Needle Pack	2	-----
37	Check Valve	1	SK5147-101
38	Pressure Relief Valve (C23627-1)	2	-----
39	Wooden Adhesive Stirring Sticks	20	-----
40	Roll Yellow Plastic Template Marking Tape	1	-----
41	Green Base Ground Anchor Strap Ring	2	-----
42	Green Tape 12 Ft Roll	1	-----

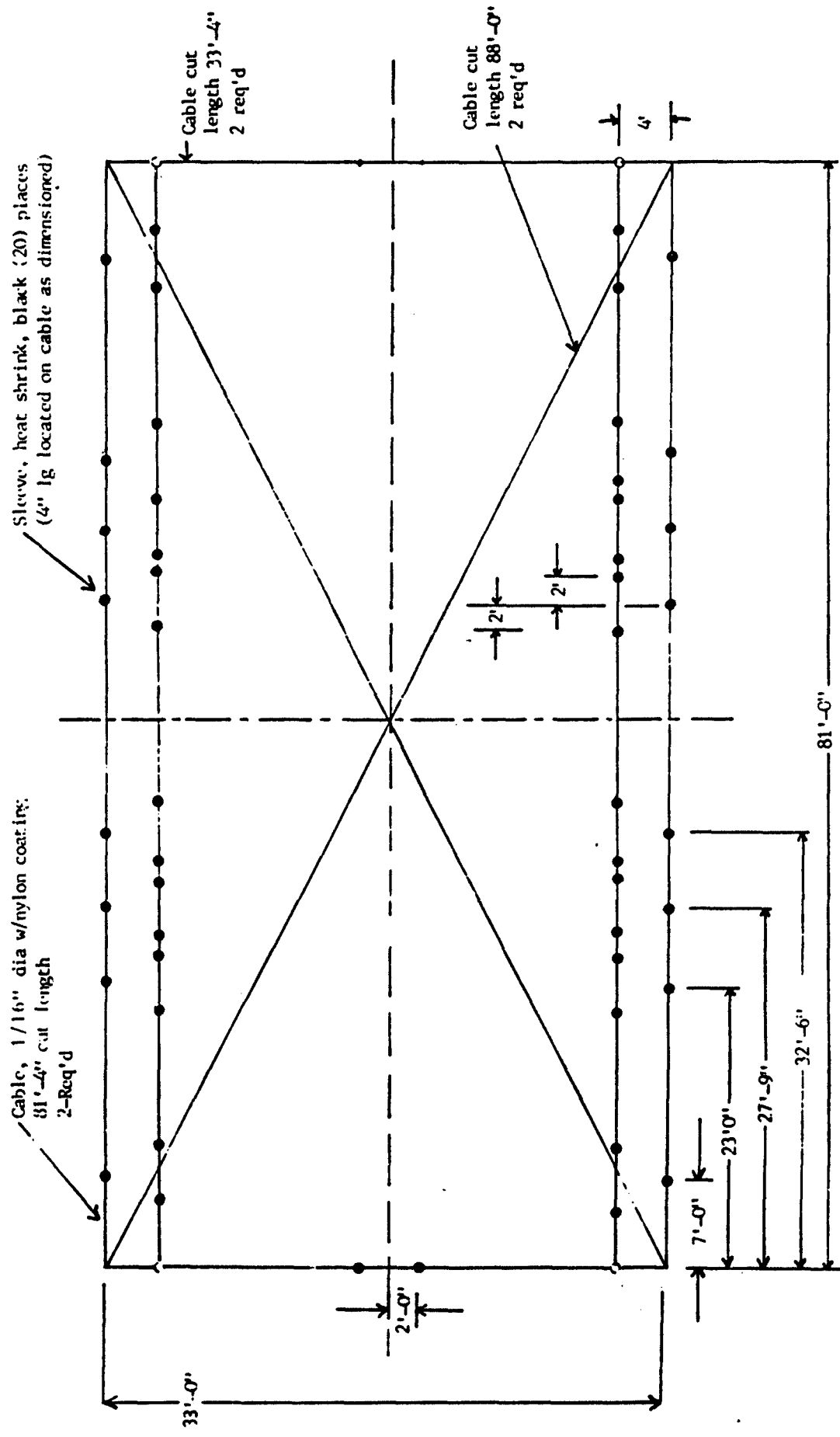



#### Section IV. Field Expedient Repairs

General. Operator/crew maintenance troubles may occur while the Transportable Helicopter Enclosure is operating in the field where supplies and repair parts are not available and normal corrective action cannot be performed. When this condition exists, the following expedient repairs may be used in emergencies upon the decision of the unit commander. Equipment so repaired must be removed from operation as soon as possible and properly repaired before being placed in operation again.

a. Torn or Otherwise Damaged Fabric or Fastener.

Trouble

Expedient Remedy

Damaged fabric

Repair damage with adhesive tape or other sealant material until normal repairs can be made.

Damaged or missing fastener  
(Becket/Lace System)

Use rope, cord, wire or other available material to replace fastener.

b. Deflated bladder assembly.

Trouble

Expedient Remedy

Arch tube damaged  
beyond repair

Use shelter with arch tube deflated until replacements are available.

c. Inflation Manifold Missing or Damaged.

Trouble

Expedient Remedy

No usable inflation  
manifold available

Inflate bladder assemblies individually by connecting air source directly to arch tube check valve.

## SINGLE ARCH TUBE INFLATION PROCEDURES

To inflate one arch tube independently after a repair, use one of the following procedures.

1. Connect one side of the manifold assembly to the check valves on the side of the shelter with the deflated arch tube. Lay the manifold assembly on the inside of the shelter.
2. Connect the manifold assembly directly to the blower.
3. Turn on the blower.
4. Place check valve of deflated arch tube in the open position.
5. Inflate the arch tube for approximately two minutes and close the valve.
6. Repack manifold and blower.

### Alternate Method

1. Move the blower close to the deflated arch tube.
2. Connect one end of a manifold assembly directly to the blower.
3. Connect the first check valve hose to the deflated arch tube.
4. Gently twist and grasp the manifold assembly on the other side of the check valve hose away from blower to prevent air from escaping.
5. Turn on the blower.
6. Open the check valve, inflate for approximately two minutes and close the valve.
7. Turn off the blower and repack the manifold hoses.

**NOTE: IF AN ARCH TUBE HAS TO INFLATED AND IT IS NOT CONVENIENT TO STRIKE THE SHELTER OR ATTACH THE BLOWER, USE THE FOLLOWING METHOD.**

1. Remove a manifold assembly from the manifold cover.
2. Locate the capped end.
3. Attach the check valve hose next to the capped end to the deflated arch tube.
4. Attach the adjacent check valve hose to the nearest fully inflated arch tube.

5. Close off the rest of the manifold assembly by gently twisting the hose and grasping firmly.
6. Open both arch tube check valves for approximately two minutes.
7. Close both check valves.
8. Disconnect and repack the manifold assembly.

NOTE: FOR ALL EMERGENCY REPAIRS USE THE GREEN TAPE PROVIDED IN THE REPAIR KIT.

#### Manifold Repair

To repair the manifold assembly, use the arch tube repair materials and instructions.

To repair the remaining hoses, use the green tape provided in the repair kit.

Section V

Maintenance Allocation Chart

Transportable Helicopter Enclosure (THE)

Group No.	Component/ Assembly	Maintenance Function	Maintenance Level					Tools and Equipment	Remarks
			C	O	F	H	D		
01	Erection Kit	Inspect Replace	x						A
				x					
02	Enclosure Components								
	Rope & Cable Assemblies	Inspect Adjust Replace Repair	x x		x x			1	
	Bracket Loop Assembly	Inspect Replace Repair	x		x x			1,2,3	
	Zipper Assembly	Inspect Replace Repair	x		x x			1,2,3	
	Weather Barrier	Inspect Repair	x		x			1,2	B,D
	Valves	Inspect Service Replace	x		x x			1,2	C
	Arch Tube Lateral Straps	Inspect Replace Repair	x		x	x		1,2	D
	Tube Assembly	Inspect Repair	x		x			1,2	B,D

Maintenance Allocation Chart (cont'd)

Group No.	Component/ Assembly	Maintenance Function	Maintenance Level					Tools and Equipment	Remarks
			C	O	F	H	D		
	Inflation System								
	Manifolds & Junction	Inspect	x						
		Adjust	x						
		Replace			x				
		Repair			x			1,2	
	Blower Assembly	Inspect	x						
		Service	x						
		Replace			x				
		Repair				x			
	Repair Kit	Inspect	x						
		Replace			x			A	

### Maintenance Allocation Chart

Reference Code	Remarks
A	Replace components unless more economical to replace the entire kit.
B	Patch holes, tears, and ties using the repair kit.
C	Clean foreign matter from valves.
D	For any repairs requiring sewing refer item to next level of maintenance.
1	Fabric repair kit
2	Mechanics repair kit

#### Maintenance Level

- C Operator or crew
- O Organizational Maintenance
- F Direct Support Maintenance
- H General Support Maintenance
- L Specialized Repair Activity (SRA)
- D Depot Maintenance