

AD-A164 522

JAMMING EFFECTS ON N-ARY COHERENT AND BINARY  
NONCOHERENT DIGITAL RECEIVERS USING RANDOM JAMMER  
MODELS(U) NAVAL POSTGRADUATE SCHOOL MONTEREY CA  
L A HUNOZ DEC 85

1/2

UNCLASSIFIED

F/G 17/4

NL

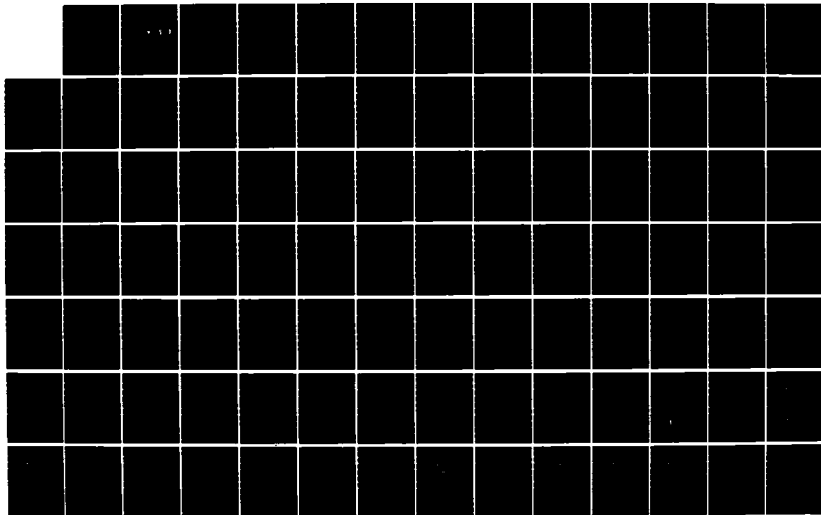

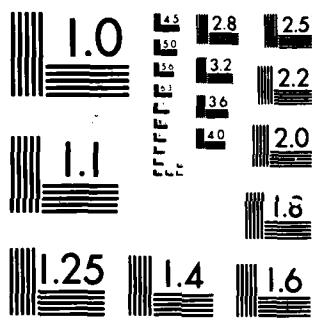

MICROCOPY RESOLUTION TEST CHART  
NATIONAL BUREAU OF STANDARDS 1963-A

2

# NAVAL POSTGRADUATE SCHOOL

Monterey, California

AD-A164 522



DTIC  
ELECTE  
FEB 25 1986  
S D  
D

## THESIS

JAMMING EFFECTS ON M-ARY COHERENT AND BINARY  
NONCOHERENT DIGITAL RECEIVERS USING  
RANDOM JAMMER MODELS

by

Luis Alberto Muñoz

December 1985

Thesis Advisor:

D. Bukofzer

DTIC FILE COPY

Approved for public release; distribution is unlimited

86 25 1986

UNCLASSIFIED

SECURITY CLASSIFICATION OF THIS PAGE

AD-A164522

## REPORT DOCUMENTATION PAGE

1a. REPORT SECURITY CLASSIFICATION Unclassified		1b. RESTRICTIVE MARKINGS	
2a. SECURITY CLASSIFICATION AUTHORITY		3. DISTRIBUTION/AVAILABILITY OF REPORT Approved for public release; distribution is unlimited	
2b. DECLASSIFICATION/DOWNGRADING SCHEDULE			
4. PERFORMING ORGANIZATION REPORT NUMBER(S)		5. MONITORING ORGANIZATION REPORT NUMBER(S)	
6a. NAME OF PERFORMING ORGANIZATION Naval Postgraduate School	6b. OFFICE SYMBOL (if applicable) Code 62	7a. NAME OF MONITORING ORGANIZATION Naval Postgraduate School	
6c. ADDRESS (City, State, and ZIP Code) Monterey, California 93943-5100		7b. ADDRESS (City, State, and ZIP Code) Monterey, California 93943-5100	
8a. NAME OF FUNDING/SPONSORING ORGANIZATION	8b. OFFICE SYMBOL (if applicable)	9. PROCUREMENT INSTRUMENT IDENTIFICATION NUMBER	
8c. ADDRESS (City, State, and ZIP Code)		10. SOURCE OF FUNDING NUMBERS	
		PROGRAM ELEMENT NO.	PROJECT NO.
		TASK NO.	WORK UNIT ACCESSION NO.
11. TITLE (Include Security Classification) JAMMING EFFECTS ON M-ARY COHERENT AND BINARY NONCOHERENT DIGITAL RECEIVERS USING RANDOM JAMMER MODELS			
12. PERSONAL AUTHOR(S) Muñoz, Luis A.			
13a. TYPE OF REPORT Master's Thesis	13b. TIME COVERED FROM _____ TO _____	14. DATE OF REPORT (Year, Month, Day) 1985, December	15. PAGE COUNT 113
16. SUPPLEMENTARY NOTATION			
COSATI CODES		18. SUBJECT TERMS (Continue on reverse if necessary and identify by block number)	
FIELD	GROUP	SUB-GROUP	
		Jamming Effects; MPSK; MFSK; BFSK	
19. ABSTRACT (Continue on reverse if necessary and identify by block number)			
<p>The purpose of this work is to analyze and evaluate the effect of jamming waveforms on both coherent and noncoherent digital communications receivers. Specifically, random processes are utilized as jamming models in which it is assumed that the jamming waveforms have been produced by a shaping filter driven by white Gaussian noise. Such jamming waveforms are then assumed to be present at the input of known receiver structures (in addition to the signals and channel noise normally present), and optimum jamming waveform spectra are determined for different receiver schemes and modulation techniques.</p> <p>Graphical results based on numerical analyses are presented in order to demonstrate the effect of different jamming strategies on receiver</p>			
20. DISTRIBUTION/AVAILABILITY OF ABSTRACT <input checked="" type="checkbox"/> UNCLASSIFIED/UNLIMITED <input type="checkbox"/> SAME AS RPT <input type="checkbox"/> DTIC USERS		21. ABSTRACT SECURITY CLASSIFICATION Unclassified	
22a. NAME OF RESPONSIBLE INDIVIDUAL Prof. Daniel C. Bukofzer		22b. TELEPHONE (Include Area Code) (408) 646-2859	22c. OFFICE SYMBOL Code 62Bh

DD FORM 1473, 84 MAR

83 APR edition may be used until exhausted

All other editions are obsolete

SECURITY CLASSIFICATION OF THIS PAGE

UNCLASSIFIED

SECURITY CLASSIFICATION OF THIS PAGE (When Data Entered)

#19 - ABSTRACT - (CONTINUED)

performance. In order to quantify receiver performance, bit error probabilities are determined for binary modulation systems and symbol error probabilities are determined for M-ary modulation systems. In each case, the error probabilities are functions of signal-to-noise ratio (SNR) and jammer-to-signal ratio (JSR). Results show that it is generally possible to significantly degrade the performance of binary as well as M-ary modulation communication receivers by introducing suitably chosen jamming waveforms.

UNCLASSIFIED

SECURITY CLASSIFICATION OF THIS PAGE (When Data Entered)

Approved for public release; distribution is unlimited.

Jamming Effects on M-ary Coherent and Binary  
Noncoherent Digital Receivers Using  
Random Jammer Models

by

Luis Alberto Muñoz  
Major, Peruvian Army  
B.S., Peruvian Army Institute of Technology, 1980

Submitted in partial fulfillment of the  
requirements for the degree of

MASTER OF SCIENCE IN ELECTRICAL ENGINEERING

from the

NAVAL POSTGRADUATE SCHOOL  
December 1985

Author:

  
Luis Alberto Muñoz

Approved by:

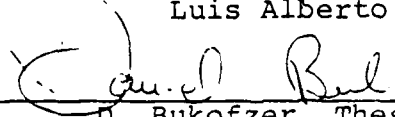
  
D. Bukofzer, Thesis Advisor

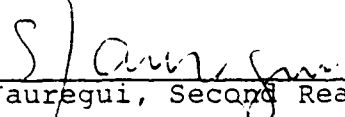
  
S. Jauregui, Second Reader

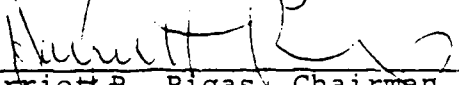
  
Harriett B. Rigas, Chairman,  
Department of Electrical and Computer Engineering

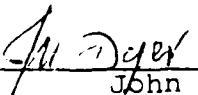
  
John N. Dyer,  
Dean of Science and Engineering

## ABSTRACT

The purpose of this work is to analyze and evaluate the effect of jamming waveforms on both coherent and noncoherent digital communications receivers. Specifically, random processes are utilized as jamming models in which it is assumed that the jamming waveforms have been produced by a shaping filter driven by white Gaussian noise. Such jamming waveforms are then assumed to be present at the input of known receiver structures (in addition to the signals and channel noise normally present), and optimum jamming waveform spectra are determined for different receiver schemes and modulation techniques.

Graphical results based on numerical analyses are presented in order to demonstrate the effect of different jamming strategies on receiver performance. In order to quantify receiver performance, bit error probabilities are determined for binary modulation systems and symbol error probabilities are determined for M-ary modulation systems. In each case, the error probabilities are functions of signal-to-noise ratio (SNR) and jammer-to-signal ratio (JSR). Results show that it is generally possible to significantly degrade the performance of binary as well as M-ary modulation communication receivers by introducing suitably chosen jamming waveforms.

TABLE OF CONTENTS

I.	INTRODUCTION -----	10
II.	COLORED NOISE INTERFERENCE IN COHERENT M-ARY PHASE SHIFT KEYED MODULATION -----	12
	A. SIGNAL DETECTION IN THE PRESENCE OF COLORED NOISE -----	12
	B. RECEIVER PERFORMANCE -----	17
III.	COLORED NOISE INTERFERENCE IN COHERENT M-ARY FREQUENCY KEYED MODULATION SYSTEMS -----	29
	A. SIGNAL DETECTION IN THE PRESENCE OF COLORED NOISE -----	29
	B. RECEIVER PERFORMANCE -----	31
IV.	NON-COHERENT BINARY FREQUENCY SHIFT KEYED SIGNAL DETECTION IN THE PRESENCE OF COLORED NOISE -----	45
	A. THE QUADRATURE RECEIVER, EQUIVALENT FORMS AND RECEIVER PERFORMANCE IN THE PRESENCE OF WHITE GAUSSIAN NOISE -----	45
	B. RECEIVER PERFORMANCE IN THE PRESENCE OF COLORED NOISE -----	49
	C. RECEIVER PERFORMANCE IN THE PRESENCE OF WHITE GAUSSIAN NOISE UNDER SINGLE CHANNEL OPERATION -----	65
	D. RECEIVER PERFORMANCE IN THE PRESENCE OF COLORED NOISE UNDER SINGLE CHANNEL OPERATION -----	69
V.	GRAPHICAL RESULTS -----	74
	A. GRAPHICAL RESULTS FOR COLORED NOISE INTERFERENCE IN COHERENT M-ARY FREQUENCY SHIFT KEYED MODULATED SYSTEMS -----	74
	B. GRAPHICAL RESULTS FOR NON-COHERENT BINARY SHIFT KEYED SIGNAL DETECTION IN THE PRESENCE OF COLORED NOISE -----	83

<input checked="" type="checkbox"/> <input type="checkbox"/> <input type="checkbox"/>
---

Distribution/	
Availability Codes	
Dist	Avail and/or Special
A-1	



VI.	CONCLUSIONS -----	98
APPENDIX A:	DETAILED INVESTIGATION OF THE VARIANCES OF $V_C$ AND $V_S$ CONDITIONED ON HYPOTHESES $H_j$ -----	101
APPENDIX B:	DETAILED INVESTIGATION OF THE BEHAVIOR OF THE PRODUCT OF $S_j'(-\omega)$ AND $S_k'(\omega)$ -----	104
APPENDIX C:	DETAILED INVESTIGATION OF THE VARIANCES $\sigma_{C,0}^2$ AND $\sigma_{C,1}^2$ DUE TO COLORED NOISE -----	107
	LIST OF REFERENCES -----	111
	INITIAL DISTRIBUTION LIST -----	112

LIST OF TABLES

5.1.	PERFORMANCE OF 2-FSK RECEIVER -----	75
5.2.	PERFORMANCE OF 4-FSK RECEIVER -----	76
5.3.	PERFORMANCE OF 8-FSK RECEIVER -----	77
5.4.	PERFORMANCE OF 16-FSK RECEIVER -----	78
5.5	PERFORMANCE OF THE QUADRATURE RECEIVER JSR = 0 -----	86
5.6.	PERFORMANCE OF THE QUADRATURE RECEIVER JSR = 0 db -----	86
5.7.	PERFORMANCE OF THE QUADRATURE RECEIVER JSR = 5 db -----	87
5.8.	PERFORMANCE OF THE QUADRATURE RECEIVER JSR = 10 db -----	87
5.9.	PERFORMANCE OF THE QUADRATURE RECEIVER JSR = 15 db -----	88
5.10.	PERFORMANCE OF THE QUADRATURE RECEIVER JSR = 20 db -----	88
5.11.	PERFORMANCE OF THE QUADRATURE RECEIVER SINGLE CHANNEL OPERATION FOR DIFFERENT JAMMING FREQUENCIES AND JSR = 5 db -----	97
5.12.	PERFORMANCE OF THE QUADRATURE RECEIVER SINGLE CHANNEL OPERATION FOR DIFFERENT JAMMING FREQUENCIES AND JSR = 10 db -----	97

## LIST OF FIGURES

2.1	MPSK Receiver -----	13
3.1	MFSK Receiver -----	30
4.1	Quadrature Receiver -----	48
4.2	Matched Filter Equivalent to Quadrature Receiver -----	48
5.1	Performance of M-ary FSK for M = 2 -----	79
5.2	Performance of M-ary FSK for M = 4 -----	80
5.3	Performance of M-ary FSK for M = 8 -----	81
5.4	Performance of M-ary FSK for M = 16 -----	82
5.5	Performance of the Quadrature Receiver for JSR = 0 -----	84
5.6	Performance of the Quadrature Receiver for JSR = 0 db -----	89
5.7	Performance of the Quadrature Receiver for JSR = 5 db -----	90
5.8	Performance of the Quadrature Receiver for JSR = 10 db -----	91
5.9	Performance of the Quadrature Receiver for JSR = 15 db -----	92
5.10	Performance of the Quadrature Receiver for JSR = 20 db -----	93
5.11	Performance of the Quadrature Receiver for Single Channel Operation for Different Jamming Frequencies and JSR = 5 db -----	95
5.12	Performance of the Quadrature Receiver for Single Channel Operation for Different Jamming Frequencies and JSR = 10 db -----	96

### ACKNOWLEDGMENTS

I wish to express my appreciation to my thesis advisor Professor Daniel Bukofzer for his efforts, guidance, patience and friendship which contributed to the completion of this work. I would also like to express my gratitude to my wife Eliana for her support, and my love to my children to whom this work is dedicated.

## I. INTRODUCTION

The theory of statistical signal detection and estimation in the presence of additive white Gaussian noise is widely described in many textbooks [Refs. 1,2,3]. Signal detectors are typically designed and built to either optimize the receiver output signal to noise ratio, or as is the case with digital communications receivers, to minimize the error probability.

While it has been demonstrated that receivers designed under a white noise interference assumption tend to perform reasonably well even when the interference is not white [Ref. 4], the assumption of white noise interference is often invalid, especially when the receiver must operate in a jamming environment.

The goal of this thesis is to analyze the vulnerability of certain digital communications receivers designed to operate in a white noise interference environment, that must operate in the presence of jamming also. The mathematical model of the jamming utilized is a colored Gaussian noise process whose power spectral density is to be shaped in such a manner so as to cause a large increase in the receiver probability of error. While it is not always possible to solve certain spectral shaping optimization problems, it is possible to postulate techniques that intuitively achieve efficient utilization of the available jammer power.

This thesis is divided up as follows. In Chapter II, we present results on colored noise interference effects in coherent M-ary Phase Shift Keyed (MPSK) receivers, and receiver symbol error probability in the presence of noise and jamming is derived. In Chapter III we analyze and determine performance of a coherent M-ary Frequency Shift Keyed (MFSK) receiver operating in the presence of noise and jamming. Chapter IV deals with non-coherent Binary Frequency Shift Keyed (BFSK) signal detection in the presence of noise and jamming. The performance of the well-known quadrature receiver is analyzed under dual channel and single channel operation. In Chapter V graphical results are presented and discussed, and performance comparisons are carried out. The conclusions and interpretations of the results obtained are presented in Chapter VI.

## II. COLORED NOISE INTERFERENCE EFFECTS IN COHERENT M-ARY PHASE SHIFT KEYED MODULATION

### A. SIGNAL DETECTION IN THE PRESENCE OF COLORED NOISE

The system whose performance is to be analyzed is described in Fig. 2.1. The structure shown is the optimum receiver for recovery of MPSK modulated data, in the presence of additive white Gaussian noise. In PSK modulation, the source (or modulator) transmits one of  $M$  signals  $s_i(t)$ , where  $i = 1, 2, \dots, M$ , over a prescribed time interval. Because in transmissions and reception these signals are interfered with by noise, at the receiver one observes the signal  $r(t)$  rather than just one of the transmitted signals. Using hypothesis testing concepts, we say that under hypotheses  $H_i$ ,  $r(t)$  takes on the form

$$H_i: \quad r(t) = \sqrt{E} \, s_i(t) + w(t) + n_c(t) \quad (2.1)$$

$$0 \leq t \leq T, \quad i = 1, 2, \dots, M$$

where for  $M$ -ary PSK modulation

$$s_i(t) = \sqrt{2/T} \cos \left( \frac{2\pi kt}{T} + \frac{2\pi(i-1)}{M} \right) \quad (2.2)$$

$$i = 1, 2, \dots, M$$

$k$  is an integer

Here  $W(t)$  is a sample function of a white Gaussian noise process of Power Spectral Density level  $N_0/2$  and  $n_c(t)$  is a

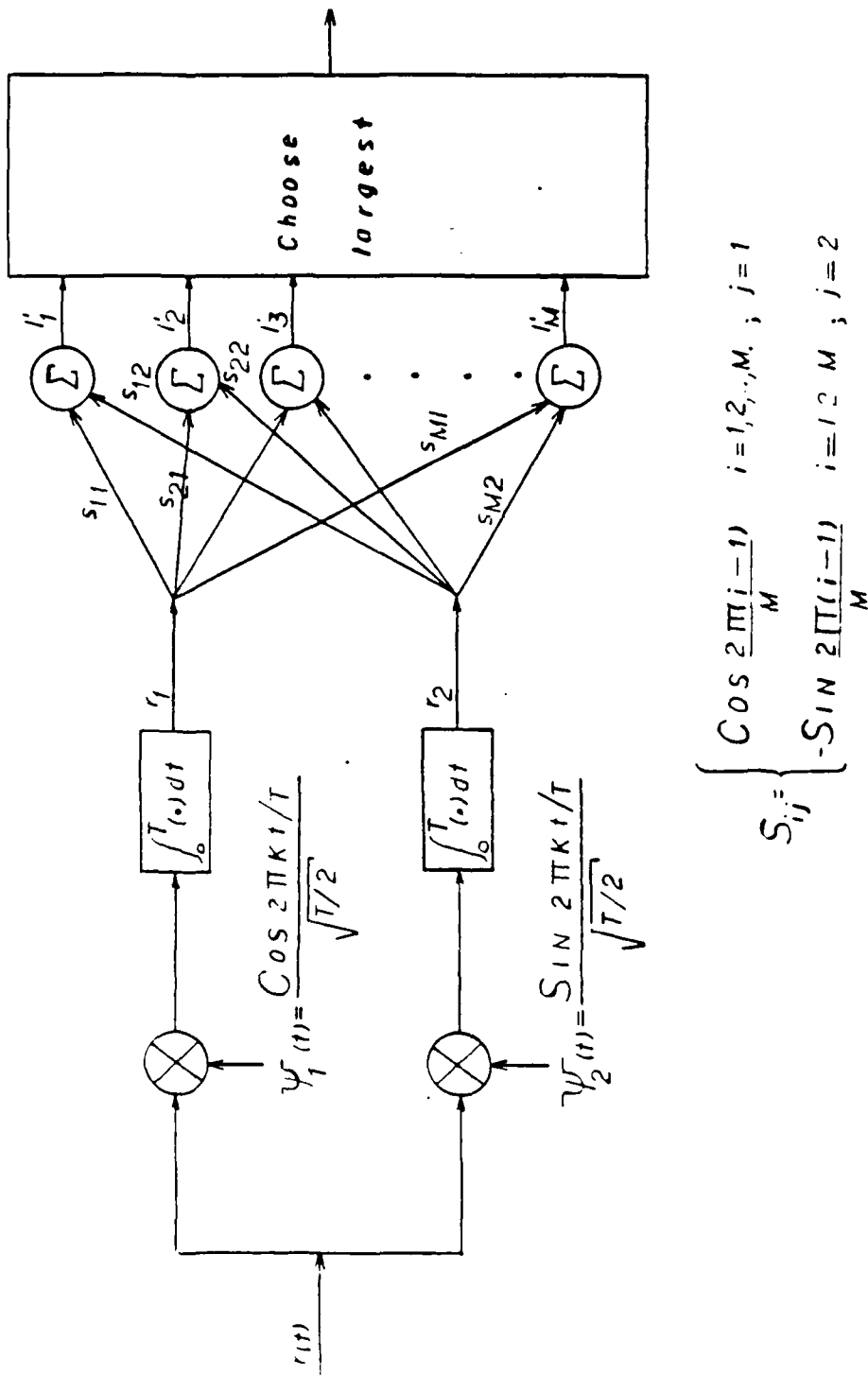

Figure 2.1. MPSK Receiver



sample function of a colored Gaussian noise process having autocorrelation function  $K_c(\tau)$ . We assume also  $w(t)$  and  $n_c(t)$  are statistically independent random processes.

The receiver of Fig. 2.1 is, as previously pointed out, an optimum processor (in minimum error probability sense) when  $n_c(t) \equiv 0$ . The analysis that follows evaluates the effect of  $n_c(t)$  on the performance of this receiver. Since  $n_c(t)$  may represent some form of jamming, the error probability expression to be derived can be used to determine the vulnerability of such a receiver to colored noise jamming, or conversely, to determine the colored noise spectrum that most effectively causes poor or inadequate receiver performance, namely, high error probability.

The signals  $S_i(t)$ ,  $i = 1, 2, 3, \dots, M$  can be shown to have cross-correlation coefficients

$$\rho_{ij} \triangleq \int_0^T S_i(t) S_j(t) dt = \cos \frac{2\pi(i-j)}{M} \quad (2.3)$$

$$i, j = 1, 2, \dots, M$$

The receiver takes advantage of the fact that we can express the  $S_i(t)$  functions,  $i = 1, 2, \dots, M$ , as an exact (rather than approximate) expression of a linear combination of two functions  $\psi_1(t)$  and  $\psi_2(t)$ . In other words

$$S_i(t) = \sum_{n=1}^2 S_{in} \psi_n(t) \quad i = 1, 2, 3, \dots, M \quad (2.4)$$

with

$$S_{in} = \int_0^T S_i(t) \psi_n(t) dt \quad \begin{array}{l} n = 1, 2; \\ i = 1, 2, \dots, M \end{array} \quad (2.5)$$

These basis functions  $\psi_1(t)$  and  $\psi_2(t)$  can be derived via a Gram-Schmitt orthonormalization procedure (or almost by inspection in this case). It turns out that  $\psi_1(t)$  and  $\psi_2(t)$  (which must be orthogonal) are given by

$$\psi_1(t) = \frac{\cos 2\pi kt/T}{\sqrt{T/2}} \quad (2.6)$$

and

$$\psi_2(t) = \frac{\sin 2\pi kt/T}{\sqrt{T/2}} \quad (2.7)$$

where  $k$  is an integer.

It can be easily shown that

$$S_{i1} = \cos \frac{2\pi(i-1)}{M}; \quad i = 1, 2, \dots, M \quad (2.8)$$

and

$$S_{i2} = -\sin \frac{2\pi(i-1)}{M}; \quad i = 1, 2, \dots, M \quad (2.9)$$

We define

$$\theta_i = 2\pi(i-1)/M \quad i = 1, 2, \dots, M \quad (2.10)$$

and assuming equal prior probabilities, namely, each signal is equally likely to be transmitted, the receiver computes

$$\lambda'_i = \sum_{n=1}^2 s_{in} r_n \quad i = 1, 2, \dots, M \quad (2.11)$$

and makes decisions based on which  $\lambda'_i$  value is largest. Thus with

$$r_n = \int_0^T r(t) \psi_n(t) dt \quad n = 1, 2 \quad (2.12)$$

we have

$$\begin{aligned} \lambda'_i &= \left[ \cos \theta_i \right] \int_0^T r(t) \psi_1(t) dt \\ &\quad + \left[ -\sin \theta_i \right] \int_0^T r(t) \psi_2(t) dt \quad i = 1, 2, \dots, M \end{aligned} \quad (2.13)$$

and using simple trigonometric identities,

$$\lambda'_i = V \cos(\theta_i + \phi) \quad i = 1, 2, \dots, M \quad (2.14)$$

Clearly

$$v = \{V_c^2 + V_s^2\}^{1/2} \quad (2.15)$$

where

$$V_c = \int_0^T r(t) \psi_1(t) dt, \quad (2.16)$$

$$V_s = \int_0^T r(t) \psi_2(t) dt \quad (2.17)$$

and

$$\eta = \tan^{-1} \frac{V_s}{V_c} \quad (2.18)$$

#### B. RECEIVER PERFORMANCE

Since conditioned on any hypothesis  $H_i$ ,  $i = 1, 2, \dots, M$ ,  $V_c$  and  $V_s$  are Gaussian random variables, we can obtain the statistics of the appropriate random variables, in the following manner. First, we have

$$\begin{aligned} E\{V_c/H_j\} &= E\left\{\int_0^T [\sqrt{E} S_j(t) + w(t) + n_c(t)] \psi_1(t) dt\right\} \\ &= \sqrt{E} \int_0^T S_j(t) \psi_1(t) dt = \sqrt{E} S_{j1} \quad j = 1, 2, \dots, M. \end{aligned} \quad (2.19)$$

$$\begin{aligned}
E\{V_s/H_j\} &= E\left\{\int_0^T [\sqrt{E} S_j(t) + w(t) + n_c(t)] \psi_2(t) dt\right\} \\
&= \sqrt{E} \int_0^T S_j(t) \psi_2(t) dt = \sqrt{E} S_{j2} \quad (2.20) \\
&\quad j = 1, 2, 3, \dots, M
\end{aligned}$$

also

$$\begin{aligned}
\text{var}\{V_c/H_j\} &= E\left\{\left[\int_0^T [w(t) + n_c(t)] \psi_1(t) dt\right]^2\right\} \\
&= E\left\{\int_0^T \int_0^T [w(t) + n_c(t)] [w(\tau) + n_c(\tau)] \psi_1(t) \psi_1(\tau) dt d\tau\right\} \\
&= \frac{N_0}{2} + \int_0^T \int_0^T K_c(t-\tau) \psi_1(t) \psi_1(\tau) dt d\tau \quad (2.21)
\end{aligned}$$

and

$$\begin{aligned}
\text{var}\{V_s/H_j\} &= E\left\{\left[\int_0^T [w(t) + n_c(t)] \psi_2(t) dt\right]^2\right\} \\
&= E\left\{\int_0^T \int_0^T [w(t) + n_c(t)] [w(\tau) + n_c(\tau)] \psi_2(t) \psi_2(\tau) dt d\tau\right\} \\
&= \frac{N_0}{2} + \int_0^T \int_0^T K_c(t-\tau) \psi_2(t) \psi_2(\tau) dt d\tau \quad (2.22)
\end{aligned}$$

In Appendix A we demonstrate that

$$\begin{aligned}
& \int_0^T \int_0^T K_C(t-\tau) \psi_1(t) \psi_1(\tau) dt d\tau \\
&= \int_0^T \int_0^T K_C(t-\tau) \psi_2(t) \psi_2(\tau) dt d\tau \triangleq \sigma_C^2 \quad (A.7)
\end{aligned}$$

so that  $V_C$  and  $V_S$  conditioned on  $H_j$  have identical variances. Observe also that

$$\begin{aligned}
& E\{[V_C - E\{V_C/H_j\}][V_S - E\{V_S/H_j\}]/H_j\} \\
&= E\left\{\int_0^T [w(t) + n_C(t)] \psi_1(t) dt \int_0^T [w(\tau) + n_C(\tau)] \psi_2(\tau) d\tau\right. \\
&= \iint_{00}^{TT} \frac{N_0}{2} \delta(t-\tau) \psi_1(t) \psi_2(\tau) dt d\tau \\
&\quad \left. + \int_0^T \int_0^T K_C(t-\tau) \psi_1(t) \psi_2(\tau) dt d\tau \right. \quad (2.23)
\end{aligned}$$

We can observe that the first double integral in Eq. 2.23 is zero, so that

$$\begin{aligned}
& E\{[V_C - E\{V_C/H_j\}][V_S - E\{V_S/H_j\}]/H_j\} \\
&= \iint_{00}^{TT} K_C(t-\tau) \psi_1(t) \psi_2(\tau) dt d\tau \triangleq \sigma_{1,2}^2 \quad (2.24)
\end{aligned}$$

We demonstrate in Appendix A that in general  $\sigma_{1,2}^2$  is not zero so that  $V_C$  and  $V_S$  conditioned on  $H_j$  may not be uncorrelated.

However we are still able to express the joint probability density function of  $V_c$  and  $V_s$  by using the general form [Ref. 5] of an N-dimensional Gaussian random vector  $\underline{X}$ , namely,

$$P_{\underline{X}}(\underline{X}) = \frac{1}{(2\pi)^{N/2} |\underline{\Lambda}|^{1/2}} \exp \left\{ -\frac{1}{2} (\underline{X} - \underline{m}_X)^T \underline{\Lambda}^{-1} (\underline{X} - \underline{m}_X) \right\} \quad (2.25)$$

where

$$\underline{m}_X = E\{\underline{X}\} \quad (2.26)$$

and

$$\underline{\Lambda} = E\left\{ (\underline{X} - \underline{m}_X) (\underline{X} - \underline{m}_X)^T \right\} \quad (2.27)$$

In our case, we have a 2-dimensional problem in which (see Eqs. 2.19 and 2.20),

$$\underline{m}_X = \begin{bmatrix} \sqrt{E} S_{j1} \\ \sqrt{E} S_{j1} \end{bmatrix} \quad j = 1, 2, \dots, M \quad (2.28)$$

and

$$\underline{\Lambda} = \begin{bmatrix} \frac{N_0}{2} + \sigma_c^2 & \sigma_{1,2}^2 \\ \sigma_{1,2}^2 & \frac{N_0}{2} + \sigma_c^2 \end{bmatrix} \quad (2.29)$$

so that

$$\underline{\Lambda}^{-1} = \frac{1}{\left( \frac{N_0}{2} + \sigma_c^2 \right)^2 - \sigma_{1,2}^2} \begin{bmatrix} \frac{N_0}{2} + \sigma_c^2 & -\sigma_{1,2}^2 \\ -\sigma_{1,2}^2 & \frac{N_0}{2} + \sigma_c^2 \end{bmatrix} \quad (2.30)$$

It is simple to show that

$$\Lambda_x^{-1} = \begin{bmatrix} (\frac{N_0}{2} + \sigma_c^2)/\Delta & -\sigma_{1,2}^2/\Delta \\ -\sigma_{1,2}^2/\Delta & (\frac{N_0}{2} + \sigma_c^2)/\Delta \end{bmatrix} \quad (2.31)$$

Thus

$$P_{V_c, V_s/H_j}(V_c, V_s/H_j) = \frac{1}{\sqrt{(2\pi)^2 \Delta}} \exp \left\{ -\frac{1}{2} \begin{bmatrix} V_c - \sqrt{E} S_{j1} \\ V_s - \sqrt{E} S_{j2} \end{bmatrix}^T \right. \\ \left. \times \begin{bmatrix} (\frac{N_0}{2} + \sigma_c^2)/\Delta & -\sigma_{1,2}^2/\Delta \\ -\sigma_{1,2}^2/\Delta & (\frac{N_0}{2} + \sigma_c^2)/\Delta \end{bmatrix} \begin{bmatrix} V_c - \sqrt{E} S_{j1} \\ V_s - \sqrt{E} S_{j2} \end{bmatrix} \right\} \quad (2.32)$$

with  $j = 1, 2, \dots, M$ .

Now we need to obtain from this probability density function the joint probability density function of  $V$  and  $\eta$  conditioned on  $H_j$ . This type of transformation [Ref. 6] is well known and can be used here to obtain

$$P_{V, \eta/H_j}(V, \eta/H_j) = VP_{V_c, V_s/H_j}(V \cos \eta, V \sin \eta/H_j) \\ + VP_{V_c, V_s/H_j}(-V \cos \eta, -V \sin \eta/H_j), \quad V \geq 0, \quad 0 \leq \eta \leq \pi. \quad (2.33)$$

Using the probability density function of  $V_c$  and  $V_s$  (Eqn. 2.32) yields

$$P_{V, \eta/H_j}(V, \eta/H_j) = \frac{V}{\sqrt{(2\pi)^2 \Delta}} \exp \left\{ \frac{1}{2} \begin{bmatrix} V \cos \eta - \sqrt{E} S_{j1} \\ V \sin \eta - \sqrt{E} S_{j2} \end{bmatrix}^T \begin{bmatrix} a & -b \\ -b & a \end{bmatrix} \begin{bmatrix} V \cos \eta - \sqrt{E} S_{j1} \\ V \sin \eta - \sqrt{E} S_{j2} \end{bmatrix} \right\} \\ + \frac{V}{\sqrt{(2\pi)^2 \Delta}} \exp \left\{ \frac{1}{2} \begin{bmatrix} -V \cos \eta - \sqrt{E} S_{j1} \\ -V \sin \eta - \sqrt{E} S_{j2} \end{bmatrix}^T \begin{bmatrix} a & -b \\ -b & a \end{bmatrix} \begin{bmatrix} -V \cos \eta - \sqrt{E} S_{j1} \\ -V \sin \eta - \sqrt{E} S_{j2} \end{bmatrix} \right\}, \quad V \geq 0, \quad 0 \leq \eta \leq \pi. \quad (2.33)$$



and

$$a = \left(\frac{N_0}{2} + \sigma_c^2\right) / \Delta \quad (2.34)$$

$$b = \sigma_{1,2}^2 / \Delta \quad (2.35)$$

This probability density function can be expressed in the form

$$\begin{aligned}
 P_{V, \eta / H_j}(V, \eta / H_j) &= \frac{V}{\sqrt{(2\pi)^2 \Delta}} \exp\left\{-\frac{1}{2}[a(V \cos \eta + \sqrt{E}S_{j1})^2 \right. \\
 &\quad \left. + a(V \sin \eta - \sqrt{E}S_{j2})^2 \right. \\
 &\quad \left. - 2b(V \sin \eta - \sqrt{E}S_{j2})(V \cos \eta - \sqrt{E}S_{j1})\right\} \\
 &+ \frac{V}{\sqrt{(2\pi)^2 \Delta}} \exp\left\{-\frac{1}{2}[a(V \cos \eta + \sqrt{E}S_{j1})^2 + a(V \sin \eta + \sqrt{E}S_{j2})^2 \right. \\
 &\quad \left. - 2b(V \sin \eta + \sqrt{E}S_{j2})(V \cos \eta + \sqrt{E}S_{j1})\right\} \quad (2.36)
 \end{aligned}$$

which can be simplified somewhat.

Observe that the exponential of the first term simplifies to

$$\begin{aligned}
 a[V^2 + E - 2V\sqrt{E}(S_{j1} \cos \eta + S_{j2} \sin \eta)] - 2b[V^2 \sin \eta \cos \eta \\
 - V\sqrt{E}(S_{j1} \sin \eta + S_{j2} \cos \eta) + ES_{j1}S_{j2}] \quad (2.37)
 \end{aligned}$$

and the exponential of the second term simplifies to

$$\begin{aligned}
& a[V^2 + E + 2V\sqrt{E}(S_{j1} \cos n + S_{j2} \sin n)] - 2b[V^2 \sin n \cos n \\
& + V\sqrt{E}(S_{j1} \sin n + S_{j2} \cos n) + ES_{j1}S_{j2}] \quad (2.38)
\end{aligned}$$

We can now group certain terms together. Observe from Eq. 2.8, Eq. 2.9 and Eq. 2.10 that

$$\begin{aligned}
S_{j1} \cos n + S_{j2} \sin n &= \cos \theta_j \cos n - \sin \theta_j \sin n \\
&= \cos(\theta_j + n) \quad (2.39)
\end{aligned}$$

also

$$\begin{aligned}
S_{j1} \sin n + S_{j2} \cos n &= \cos \theta_j \sin n - \sin \theta_j \cos n \\
&= \sin(n - \theta_j) \quad (2.40)
\end{aligned}$$

for  $j = 1, 2, \dots, M$ , so from Eq. 2.36 we have

$$\begin{aligned}
P_{V, n/H_j}(V, n/H_j) &= \frac{V}{\sqrt{(2\pi)^2 \Delta}} \exp\left\{-\frac{1}{2}[a[V^2 + E - 2V\sqrt{E}\cos(\theta_j + n)]\right. \\
&\quad \left. - 2b[V^2 \sin n \cos n - V\sqrt{E}\sin(n - \theta_j) - E \cos \theta_j \sin \theta_j]\right\} \\
&\quad + \frac{V}{\sqrt{(2\pi)^2 \Delta}} \exp\left\{-\frac{1}{2}[a[V^2 + E + 2V\sqrt{E}\cos(\theta_j + n)]\right. \\
&\quad \left. - 2b[V^2 \sin n \cos n + V\sqrt{E}\sin(n - \theta_j) - E \cos \theta_j \sin \theta_j]\right\} \quad (2.41)
\end{aligned}$$

for  $V \geq 0$  and  $0 \leq n \leq \pi$ .

Since

$$\cos(\theta_j + n) = -\cos(\theta_j + n + \pi) \quad (2.42)$$

and

$$\sin(\eta - \theta_j) = -\sin(\eta - \theta_j + \pi) \quad (2.43)$$

we have

$$\begin{aligned} P_{V, \eta/H_j}(V, \eta/H_j) &= \frac{V}{\sqrt{(2\pi)^2 \Delta}} \left[ \exp\left\{-\frac{1}{2}a[V^2 + E - 2V\sqrt{E}\cos(\theta_j + \eta)]\right\} \right. \\ &\quad \left. - 2b[V^2 \sin \eta \cos \eta - V\sqrt{E}\sin(\eta - \theta_j) - E \cos \theta_j \sin \theta_j] \right] \\ &+ \exp\left\{-\frac{1}{2}a[V^2 + E - 2V\sqrt{E}\cos(\theta_j + \eta + \pi)]\right\} \left[ -2b[V^2 \sin \eta \cos \eta \right. \\ &\quad \left. - V\sqrt{E}\sin(\eta - \theta_j + \pi) - E \cos \theta_j \sin \theta_j] \right] \quad (2.44) \end{aligned}$$

for  $V \geq 0$  and  $0 \leq \eta \leq \pi$ .

It is apparent from the range of  $\eta$  that the two exponential terms can be replaced by a single term with  $\eta$  ranging from 0 to  $2\pi$ .

Thus, we have

$$\begin{aligned} P_{V, \eta/H_j}(V, \eta/H_j) &= \frac{V}{\sqrt{(2\pi)^2 \Delta}} \exp\left\{-\frac{1}{2}a[V^2 + E - 2V\sqrt{E}\cos(\theta_j + \eta)]\right\} \\ &\quad \left[ -2b[V^2 \sin \eta \cos \eta - V\sqrt{E}\sin(\eta - \theta_j) - E \cos \theta_j \sin \theta_j] \right] \quad (2.45) \end{aligned}$$

for  $V \geq 0$  and  $0 \leq \eta \leq 2\pi$ . The probability density function of  $V$  conditioned on  $H_j$  is obtained via integration of  $P_{V, \eta/H_j}(V, \eta/H_j)$ , namely,

$$P_{n/H_j}(n/H_j) = \int_{-\infty}^{\infty} P_{V,n/H_j}(V,n/H_j) dV \quad (2.46)$$

Returning to our decision rule, (Eq. 2.14), recall that we decide based on which

$$\lambda'_i = V \cos(\theta_i + n) \quad i = 1, 2, \dots, M \quad (2.14)$$

is largest.

So, if  $H_j$  is the true hypothesis, then a correct decision is made if

$$V \cos(\theta_j + n) > V \cos(\theta_i + n); \quad i = 1, 2, \dots, M \\ i \neq j \quad (2.47)$$

Since  $\cos x$  is maximum when  $|x|$  is minimum, we see that if  $H_j$  is the true hypothesis, a correct decision is made if

$$|\theta_j + n| < |\theta_i + n| \quad i = 1, 2, \dots, M \\ i \neq j \quad (2.48)$$

Now from Eq. 2.9 we know that,

$$\theta_j = 2\pi(j-1)/M$$

So Eq. 2.54 is satisfied for  $n$  in the region

$$-\pi_j - \frac{\pi}{M} < n < -\pi_j + \frac{\pi}{M} \quad (2.49)$$

Thus, the probability of making a correct decision, given that  $H_j$  is the true hypothesis,  $\text{Pr}\{C|H_j\}$ , is given by

$$\Pr\{c/H_j\} = \int_{-\theta_j - \frac{\pi}{M}}^{-\theta_j + \frac{\pi}{M}} P_{n/H_j}(n/H_j) dn \quad (2.50)$$

If we make the variable change

$$\beta = n + \theta_j \quad (2.51)$$

Then Eq. 2.50 becomes

$$\Pr\{c/H_j\} = \int_{-\pi/M}^{\pi/M} P_{n/H_j}(\beta - \theta_j/H_j) d\beta \quad (2.52)$$

Now from Eq. 2.45 and Eq. 2.46 we have

$$P_{n/H_j}(n/H_j) = \int_0^{\infty} \frac{v}{\sqrt{(2\pi)^2 \Delta}} \exp\left\{-\frac{1}{2}[a[V^2 + E - 2V\sqrt{E} \cos(\theta_j + n)] - 2b[V^2 \sin n \cos n - V\sqrt{E} \sin(n - \theta_j) - E \cos \theta_j \sin \theta_j]]\right\} dv \quad (2.53)$$

$$0 \leq n \leq 2\pi$$

so that

$$P_{n/H_j}(\beta - \theta_j/H_j) = \int_0^{\infty} \frac{v}{\sqrt{(2\pi)^2 \Delta}} \exp\left\{-\frac{1}{2}[a[V^2 + E - 2V\sqrt{E} \cos \beta] - b[V^2 \sin 2(\beta - \theta_j) - 2V\sqrt{E} \sin(\beta - 2\theta_j) - E \sin 2\theta_j]]\right\} dv \quad (2.54)$$

and Eq. 2.52 now becomes

$$\Pr\{c/H_j\} = \int_{-\pi/M}^{\pi/M} \int_0^{\infty} \frac{V}{\sqrt{(2\pi)^2 \Delta}} \exp\left\{-\frac{1}{2}[a[V^2+E-2V\sqrt{E}\cos \beta - b[V^2 \sin 2(\beta-\theta_j)-2V\sqrt{E}\sin(\beta-2\theta_j)-E \sin 2\theta_j]]]\right\} dV d\beta \quad (2.55)$$

Since the hypotheses have been assumed to be equally likely, we have

$$\Pr\{c\} = \frac{1}{M} \sum_{j=1}^M \Pr\{c/H_j\} \quad (2.56)$$

so that

$$\begin{aligned} P_e &= 1 - \Pr\{c\} \\ &= 1 - \frac{1}{M} \sum_{j=1}^M \int_{-\pi/M}^{\pi/M} \int_0^{\infty} \frac{V}{\sqrt{(2\pi)^2 \Delta}} \exp\left\{-\frac{1}{2}[a[V^2+E - 2V\sqrt{E} \cos \beta - b[V^2 \sin 2(\beta-\theta_j)-2V\sqrt{E}\sin(\beta-2\theta_j)-E \sin 2\theta_j]]]\right\} dV d\beta \end{aligned} \quad (2.57)$$

Observe that if colored noise is not present, then from Equations 2.24, 2.30 and 2.35,  $\Delta = (N_0/2)^2$  and  $b = 0$ , so that Eq. 2.57 simplifies to the well-known expression for the performance of the M-PSK receiver operating in the presence of additive WGN. That is,

$$P_e = 1 - \int_{-\pi/M}^{\pi/M} \int_0^{\infty} \frac{V}{2\pi N_o/2} \exp\left\{-\frac{1}{2}\left[\frac{N_o}{2}\left[V^2 - 2V\sqrt{E} \cos \beta + E\right]\right]\right\} dV d\beta \quad (2.58)$$

where in Eq. 2.57, the dependence on the index  $j$  disappears when  $b = 0$ . While Eq. 2.57 yields a mathematical result on the performance on the M-PSK receiver in the presence of WGN and colored noise jamming, its further analysis represents a separate project in itself. Not only must Eq. 2.57 be optimized for energy constrained jamming but also it must be evaluated when the jamming spectrum takes on some simple forms. For this reason, no effort has been made to further develop the above results.

### III. COLORED NOISE INTERFERENCE IN COHERENT M-ARY FREQUENCY SHIFT KEYED MODULATED SYSTEMS

#### A. SIGNAL DETECTION IN THE PRESENCE OF COLORED NOISE

The structure of the demodulator whose performance is to be analyzed is shown in Fig. 3.1. This receiver is known to be optimum for deciding with minimum probability of error, which one of  $M$  different signals forming an orthogonal, equal energy set received in additive white Gaussian noise was actually transmitted. The problem analyzed here, can be stated as follows: A waveform  $r(t)$ , received in the interval  $(0, T)$ , contains one of the  $M$  signals,  $S_i(t)$ ,  $i = 1, 2, \dots, M$ , with equal probability, as well as white Gaussian noise  $w(t)$  of Power Spectral Density level  $N_0/2$  and colored Gaussian noise  $n_c(t)$  having autocorrelation function  $K_c(\tau)$ . The signals are orthogonal with energy  $\epsilon$ . That is

$$\rho_{ij} = \int_0^T S_i(t) S_j(t) dt = \begin{cases} \epsilon & i = j \\ 0 & i \neq j \end{cases} \quad (3.1)$$

The decision rule used by the receiver, is to choose  $S_i(t)$  as the transmitted signal if  $G_i$  is a maximum, where

$$G_i = \int_0^T r(t) S_i(t) dt \quad i = 1, 2, \dots, M. \quad (3.2)$$



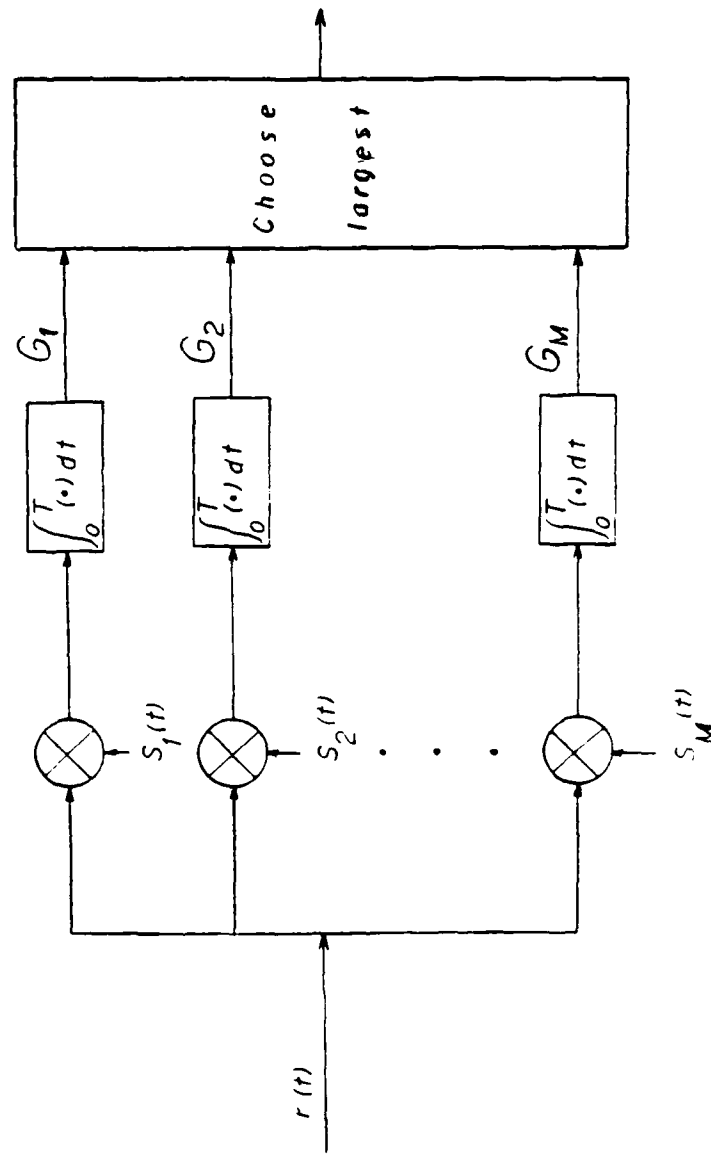

Figure 3.1. MFSK receiver

While this is an optimum test (in minimum probability of error sense) in the absence of the colored noise  $n_c(t)$ , the analysis of the next section is carried out in order to determine the effect of  $n_c(t)$  on the receiver performance. Since  $n_c(t)$  will typically be inserted in the channel by an unfriendly jammer, it is reasonable to assume that  $n(t)$  and  $n_c(t)$  are statistically independent random processes.

#### B. RECEIVER PERFORMANCE

Since  $G_i$  is the output of the  $i$ th correlator, and, conditioned on any hypothesis,  $G_i$  is a Gaussian random variable, we can obtain the appropriate conditional statistics that allow determination of  $P_e$ , namely the receiver error probability.

Thus

$$\begin{aligned} E\{G_j/H_i\} &= E\left\{\int_0^T [S_i(t)+w(t)+n_c(t)]S_j(t)dt\right\} \\ &= \int_0^T S_i(t)S_j(t)dt = \rho_{ij} \end{aligned} \quad (3.3)$$

and

$$\begin{aligned} \text{Var}\{G_j/H_i\} &= E\left\{\left[\int_0^T [w(t)+n_c(t)]S_j(t)dt\right]^2\right\} \\ &= E\left\{\int_0^T \int_0^T [w(t)+n_c(t)][w(\tau)+n_c(\tau)]S_j(t)S_j(\tau)dtd\tau\right\} \end{aligned}$$

$$\begin{aligned}
\text{Var}\{G_j/H_i\} &= \int_0^T \int_0^T \left[ \frac{N_0}{2} \delta(t-\tau) + K_c(t-\tau) \right] S_j(t) S_j(\tau) dt d\tau \\
&= \frac{N_0}{2} \int_0^T S_j(t) S_j(t) dt + \int_0^T \int_0^T K_c(t-\tau) S_j(t) S_j(\tau) dt d\tau \\
&= \frac{N_0}{2} \varepsilon + \int_0^T \int_0^T K_c(t-\tau) S_j(t) S_j(\tau) dt d\tau \quad (3.4)
\end{aligned}$$

Define

$$\sigma_{c,j}^2 \triangleq \int_0^T \int_0^T K_c(t-\tau) S_j(t) S_j(\tau) dt d\tau \quad (3.5)$$

so that

$$\text{Var}\{G_j/H_i\} = \frac{N_0}{2} \varepsilon + \sigma_{c,j}^2 \quad (3.6)$$

Observe furthermore that

$$\begin{aligned}
&E\{[G_j - E\{G_j/H_i\}][G_k - E\{G_k/H_i\}]/H_i\} \\
&= E\left\{ \int_0^T [w(t) + n_c(t)] S_j(t) dt \int_0^T [w(\tau) + n_c(\tau)] S_k(\tau) d\tau \right\} \\
&= \int_0^T \int_0^T \frac{N_0}{2} \delta(t-\tau) S_j(t) S_k(\tau) dt d\tau + \int_0^T \int_0^T K_c(t-\tau) S_j(t) S_k(\tau) dt d\tau
\end{aligned}$$

$$\begin{aligned}
& E\{[G_j - E\{G_j/H_i\}][G_k - E\{G_k/H_i\}]/H_i\} \\
&= \frac{N_0}{2} \int_0^T S_j(t)S_k(t)dt + \iint_{00}^{TT} K_c(t-\tau)S_j(t)S_k(\tau)dt d\tau \\
&= \frac{N_0}{2} \epsilon \delta_{jk} + \iint_{00}^{TT} K_c(t-\tau)S_j(t)S_k(\tau)dt d\tau \tag{3.7}
\end{aligned}$$

As can be seen from Eq. 3.7, due to the presence of the colored noise, the random variables  $\{G_j/H_i\}$  are not uncorrelated. However we will show that for MFSK with signal frequencies that are sufficiently separated, the integral

$$\iint_{00}^{TT} K_c(t-\tau)S_j(t)S_k(\tau)dt d\tau \tag{3.8}$$

vanishes for  $j \neq k$ , so that the random variables are indeed uncorrelated.

Thus, conditioned on  $H_i$ , the  $G_j$  are statistically independent. Assume now that  $S_i(t)$  is transmitted and  $G_i = x$ . Then the conditional probability of a correct decision,  $\text{Pr}\{c/H_i, G_i = x\}$  becomes

$$P\{c/H_i, G_i = x\} = P\{G_1 < x, \dots, G_{i-1} < x, G_{i+1} < x, \dots, G_M < x/H_i, G_i = x\}$$

$$= \prod_{\substack{k=1 \\ k \neq i}}^M P\{G_k < x/H_i, G_i = x\}$$

$$= \prod_{\substack{k=1 \\ k \neq i}}^M \int_{-\infty}^x \frac{1}{\sqrt{2\pi(\frac{N_0}{2}\epsilon_k + \sigma_{c,k}^2)}} \exp(-y^2/2(\frac{N_0}{2}\epsilon + \sigma_{c,k}^2)) dy \quad (3.9)$$

Introducing a change of variable,

$$z = Y/\sqrt{\frac{N_0}{2}\epsilon + \sigma_{c,k}^2} \quad (3.10)$$

we have

$$P\{c/H_i, G_i = x\} = \prod_{\substack{k=1 \\ k \neq i}}^M \int_{-\infty}^{x/\sqrt{\frac{N_0}{2}\epsilon + \sigma_{c,k}^2}} \frac{1}{\sqrt{2\pi}} e^{-z^2/2} dz \quad (3.11)$$

Now, since

$$E\{G_i/H_i\} = \epsilon \quad (3.3)$$

and

$$\text{Var}\{G_i/H_i\} = \frac{N_0}{2} \epsilon + \sigma_{c,k}^2 \quad (3.6)$$

we have that

$$P\{c/H_i\} = \int_{-\infty}^{\infty} P\{c/H_i, G_i=x\} \frac{1}{2\pi(\frac{N_0}{2}\epsilon + \sigma_{c,i}^2)} \exp\left\{-\frac{(x-\epsilon)^2}{2(\frac{N_0}{2}\epsilon + \sigma_{c,i}^2)}\right\} dx$$

so that using Eq. 3.11, we obtain

$$P\{c/H_i\} = \int_{-\infty}^{\infty} \prod_{\substack{k=1 \\ k \neq i}}^M \int_{-\infty}^{\infty} \frac{x/\sqrt{\frac{N_0}{2}\epsilon + \sigma_{c,k}^2}}{\sqrt{2\pi(\frac{N_0}{2}\epsilon + \sigma_{c,i}^2)}} \frac{1}{\sqrt{2\pi}} e^{-z^2/2} dz \exp\left\{-\frac{(x-\epsilon)^2}{2(\frac{N_0}{2}\epsilon + \sigma_{c,i}^2)}\right\} dx \quad (3.12)$$

Assume now for convenience that M is odd, and express the M-ary FSK signals as

$$S_i(t) = A \cos(\omega_c + (i - (M+1)/2)\Delta\omega)t \quad 0 < t < T \quad (3.13) \\ i = 1, 2, \dots, M$$

so that

$$\int_0^T S_i(t) e^{-j\omega t} dt = \int_{-\infty}^{\infty} S_i(t) p(t) e^{-j\omega t} dt \\ = F\{S_i(t) p(t)\} \quad i = 1, 2, \dots, M \quad (3.14)$$

where

$$p(t) = \begin{cases} 1 & 0 < t < T \\ 0 & \text{otherwise} \end{cases} \leftrightarrow P(\omega) = Te^{-j\omega T/2} \frac{\sin \omega T/2}{\omega T/2} \quad (3.15)$$

and  $S_i'(t)$  is just  $S_i(t)$  with  $-\infty \leq t \leq \infty$ . Thus

$$F\{S_i'(t)p(t)\} = \frac{1}{2\pi} \int_{-\infty}^{\infty} S_i'(\omega-\Delta)P(\Delta)d\Delta \quad (3.16)$$

where with

$$\omega_i = (i - \frac{M+1}{2})\Delta\omega \quad (3.17)$$

we have

$$S_i'(\omega) = \pi A [\delta(\omega - (\omega_c + \omega_i)) + \delta(\omega + (\omega_c + \omega_i))] \quad (3.18)$$

for  $i = 1, 2, \dots, M$ .

Thus

$$\begin{aligned} F\{S_i'(t)p(t)\} &= \frac{1}{2\pi} \int_{-\infty}^{\infty} \pi A [\delta(\omega - \nu - (\omega_c + \omega_i)) + \delta(\omega - \nu + (\omega_c + \omega_i))] Te^{-j\nu T/2} \frac{\sin \nu T/2}{\nu T/2} d\nu \\ &= \frac{AT}{2} \left[ e^{-j(\omega - \omega_c - \omega_i)T/2} \frac{\sin(\omega - \omega_c - \omega_i)T/2}{(\omega - \omega_c - \omega_i)T/2} \right. \\ &\quad \left. + e^{-j(\omega + \omega_c + \omega_i)T/2} \frac{\sin(\omega + \omega_c + \omega_i)T/2}{(\omega + \omega_c + \omega_i)T/2} \right] \quad (3.19) \end{aligned}$$

For convenience, let

$$L(\omega) = e^{-j\omega T/2} \frac{\sin \omega T/2}{\omega T/2} \quad (3.20)$$

So that Eq. 3.79 becomes

$$\begin{aligned} F\{S_i'(t)p(t)\} &= F\{S_i(t)\} = S_i(\omega) = \\ &= \frac{AT}{2} [L(\omega - \omega_c - \omega_i) + L(\omega + \omega_c + \omega_i)] \\ & \quad i = 1, 2, \dots, M \end{aligned} \quad (3.21)$$

Let us examine now the correlation coefficient  $\rho_{ij}$ , namely

$$\begin{aligned} \rho_{ij} &= \int_0^T S_i(t) S_j(t) dt = \int_0^T A \cos(\omega_c + \omega_i)t A \cos(\omega_c + \omega_j)t dt \\ &= \frac{A^2 T}{2} \left[ \frac{\sin(\omega_i - \omega_j)T}{(\omega_i - \omega_j)T} + \frac{\sin(2\omega_c + \omega_i + \omega_j)T}{(2\omega_c + \omega_i + \omega_j)T} \right] \end{aligned} \quad (3.22)$$

If we assume that  $\omega_c T \gg \pi$ , then the second term in Eq. 3.22 vanishes and we have

$$\rho_{ij} = \int_0^T S_i(t) S_j(t) dt = \frac{A^2 T}{2} \frac{\sin(i-j)\Delta\omega T}{(i-j)\Delta\omega T} \quad (3.23)$$

In order to have orthogonal signals we need at least  $\Delta\omega T = \pi$  or equivalently  $\Delta\omega = \pi/T$ . Normally, we will have

$$\Delta\omega = k\pi/T \quad (3.24)$$



where  $k$  is a large integer, so that  $\rho_{ij} \approx 0$  for  $i \neq j$ . Thus, from Eq. 3.23 and Eq. 3.24,

$$\rho_{ij} = \int_0^T S_i(t) S_j(t) dt = \begin{cases} \epsilon = A^2 T/2 & i = j \\ 0 & i \neq j \end{cases} \quad (3.25)$$

From Eq. 3.5 it appears however that the term  $\sigma_{c,i}^2$  independent of  $i$ . Nevertheless Eq. 3.12 becomes

$$P\{c/H_1\} = \int_{-\infty}^{\infty} \prod_{\substack{k=1 \\ k \neq i}}^M \int_{-\infty}^{\infty} x \sqrt{\frac{N_0}{2\epsilon + \sigma_{c,k}^2}} \frac{1}{\sqrt{2\pi}} e^{-z^2/2} dz \\ \times \frac{1}{\sqrt{2\pi(\frac{N_0}{2\epsilon + \sigma_{c,i}^2}}} \exp\left(-\frac{(x-\epsilon)^2}{2(\frac{N_0}{2\epsilon + \sigma_{c,i}^2}}\right) \quad (3.26)$$

Let

$$n = \frac{x-\epsilon}{\sqrt{\frac{N_0}{2\epsilon + \sigma_{c,i}^2}}} \quad (3.27)$$

Then

$$x = \epsilon + n \sqrt{\frac{N_0}{2\epsilon + \sigma_{c,i}^2}} \quad (3.28)$$

So that Eq. 3.26 becomes

$$P\{c/H_i\} = \int_{-\infty}^{\infty} \prod_{\substack{k=1 \\ k \neq i}}^M \int_{-\infty}^{\infty} \frac{1}{\sqrt{2\pi}} e^{-z^2/2} dz$$

$$\times \frac{1}{\sqrt{2\pi}} e^{-n^2/2} dn \quad (3.29)$$

Finally,

$$P\{c\} = \frac{1}{M} \sum_{i=1}^M P\{c/H_i\} \quad (3.30)$$

or equivalently

$$P\{c\} = \frac{1}{M} \sum_{i=1}^M \int_{-\infty}^{\infty} \prod_{\substack{k=1 \\ k \neq i}}^M \operatorname{erfc}_* \left( \frac{\varepsilon + \eta \sqrt{\frac{N_0}{2\varepsilon + \sigma_{c,i}^2}}}{\sqrt{\frac{N_0}{2\varepsilon + \sigma_{c,k}^2}}} \right) \frac{1}{\sqrt{2\pi}} e^{-n^2/2} dn \quad (3.31)$$

We must focus on the  $\sigma_{c,k}^2$  factor. Observe from Eq. 3.7 that

$$E\{[G_j - E\{G_j/H_1\}][G_k - E\{G_k/H_1\}]/H_1\}$$

$$= \frac{N_0}{2} \delta_{jk} + \int_0^T \int_0^T K_c(t-\tau) S_j(t) S_k(\tau) dt d\tau \quad (3.7)$$

and the second term becomes

$$\begin{aligned}
\int_0^T \int_0^T K_C(t-\tau) S_j(t) S_k(\tau) dt d\tau &= \int_{-\infty}^{\infty} \int_{-\infty}^{\infty} K_C(t-\tau) S_j'(t) S_k'(\tau) dt d\tau \\
&= \frac{1}{2\pi} \int_{-\infty}^{\infty} S_C(\omega) S_j'(-\omega) S_k'(\omega) d\omega
\end{aligned} \tag{3.32}$$

It has been shown in Appendix B that  $S_j'(-\omega)$  and  $S_k'(\omega)$  are essentially frequency disjoint, therefore Eq. 3.32 is zero for  $j \neq k$ . For  $j = k$ , we have (using Eq. 3.21)

$$\begin{aligned}
\sigma_{C,k}^2 &= \frac{1}{2\pi} \int_{-\infty}^{\infty} S_C(\omega) |S_k'(\omega)|^2 d\omega \\
&= \frac{A^2 T}{2} \cdot \frac{T}{2\pi} \int_{-\infty}^{\infty} S_C(\omega) |L(\omega - \omega_C - \omega_k) + L(\omega + \omega_C + \omega_k)|^2 d\omega
\end{aligned} \tag{3.33}$$

If we define

$$\begin{aligned}
I_k &= \frac{T}{2\pi} \int_{-\infty}^{\infty} S_C(\omega) |L(\omega - \omega_C - \omega_k) + L(\omega + \omega_C + \omega_k)|^2 d\omega \\
& \quad k = 1, 2, \dots, M
\end{aligned} \tag{3.34}$$

then, with  $\epsilon = A^2 T/2$  (Eq. 3.25)

$$\sigma_{C,k}^2 = \epsilon I_k \quad k = 1, 2, \dots, M \tag{3.35}$$

Thus from Eq. 3.31

$$P\{c\} = \frac{1}{M} \sum_{i=1}^M \int_{-\infty}^{\infty} \prod_{\substack{k=1 \\ k \neq i}}^M \operatorname{erfc}_* \left( \frac{\epsilon + \eta \sqrt{\frac{N_0}{2} \epsilon + \epsilon I_i}}{\sqrt{\frac{N_0}{2} \epsilon + \epsilon I_k}} \right) \frac{1}{\sqrt{2\pi}} e^{-\eta^2/2} d\eta \quad (3.36)$$

so that

$$P_e = 1 - \frac{1}{M} \sum_{i=1}^M \int_{-\infty}^{\infty} \prod_{\substack{k=1 \\ k \neq i}}^M \operatorname{erfc}_* \left( \frac{\epsilon + \sqrt{\frac{N_0}{2} \epsilon + \epsilon I_i}}{\sqrt{\frac{N_0}{2} \epsilon + \epsilon I_k}} \right) \frac{1}{\sqrt{2\pi}} e^{-\eta^2/2} d\eta \quad (3.37)$$

Observe that

$$\frac{\epsilon + \eta \sqrt{\frac{N_0}{2} \epsilon + \epsilon I_i}}{\sqrt{\frac{N_0}{2} \epsilon + \epsilon I_k}} = \frac{\eta + \sqrt{\frac{\epsilon}{\frac{N_0}{2} \epsilon + \epsilon I_i}}}{\sqrt{\frac{\epsilon N_0}{2} + \epsilon I_k}} = \frac{\eta + \sqrt{\frac{\text{SNR}}{1/2 + I_i' \text{SNR}}}}{\sqrt{\frac{1 + 2I_k' \text{SNR}}{1 + 2I_i' \text{SNR}}}} \quad (3.38)$$

Where  $\epsilon/N_0 = \text{SNR}$  and  $I_i' = \frac{I_i}{\epsilon} \approx$   $i$ th channel JSR.

Then

$$P_e = 1 - \frac{1}{M} \sum_{i=1}^M \int_{-\infty}^{\infty} \prod_{\substack{k=1 \\ k \neq i}}^M \operatorname{erfc}_* \left( \frac{\eta + \sqrt{\frac{\text{SNR}}{0.5 + I_i' \text{SNR}}}}{\sqrt{\frac{1 + 2I_k' \text{SNR}}{1 + 2I_i' \text{SNR}}}} \right) \frac{1}{\sqrt{2\pi}} e^{-\eta^2/2} d\eta \quad (3.39)$$

Consider now the following colored noise power spectral density,

$$S_c(\omega) = 2\pi K \sum_{i=1}^M [\delta(\omega + \omega_c + \omega_i) + \delta(\omega - \omega_c - \omega_i)] \quad (3.40)$$

Thus, the colored noise consists of equally weighted "tones" at the signal frequencies. Therefore, Eq. 3.34 becomes

$$\begin{aligned} I_k &= \frac{T}{2\pi} \int_{-\infty}^{\infty} 2\pi K \sum_{i=1}^M [\delta(\omega + \omega_c + \omega_i) + \delta(\omega - \omega_c - \omega_i)] |L(\omega - \omega_c - \omega_k) + L(\omega + \omega_c + \omega_k)|^2 d\omega \\ &= TK \sum_{i=1}^M [ |L(-2\omega_c - \omega_k - \omega_i) + L(\omega_k - \omega_i)|^2 + |L(\omega_i - \omega_k) + L(2\omega_c + \omega_k + \omega_i)|^2 ] \quad (3.41) \end{aligned}$$

Since  $\omega_c$  is typically large, we can justify the statement that the terms involving  $2\omega_c$  are negligible small, so that,

$$\begin{aligned} I_k &\cong TK \left[ \sum_{i=1}^M |L(\omega_k - \omega_i)|^2 + |L(\omega_i - \omega_k)|^2 \right] \\ &= 2TK \sum_{i=1}^M |L(\omega_i - \omega_k)|^2 = 2TK \sum_{i=1}^M \left( \frac{\text{Sin}(\omega_i - \omega_k) T/2}{(\omega_i - \omega_k) T/2} \right)^2 \\ &= 2TK \sum_{i=1}^M \left( \frac{\text{Sin}(i-k) \Delta\omega T/2}{(i-k) \Delta\omega T/2} \right)^2 \quad (3.42) \end{aligned}$$

With  $\Delta\omega T/2 = m\pi$  where  $m$  is large, we have

$$I_k \cong 2TK \quad \text{for } i = k \quad (3.43)$$

We can impose a constraint that

$$\begin{aligned}
P_{nj} &= \frac{1}{2\pi} \int_{-\infty}^{\infty} S_c(\omega) d\omega = K \int_{-\infty}^{\infty} \sum_{i=1}^M [\delta(\omega + \omega_c + \omega_i) + \delta(\omega - \omega_c - \omega_i)] d\omega \\
&= 2KM
\end{aligned} \tag{3.44}$$

Then

$$K = P_{nj}/2M \tag{3.45}$$

and

$$I_k \cong 2T \frac{P_{nj}}{2M} = \frac{TP_{nj}}{M} \tag{3.46}$$

Furthermore

$$I'_k = \frac{I_k}{\epsilon} = \frac{TP_{nj}}{M\epsilon} \tag{3.43}$$

and since

$TP_{nj}$  = jammer energy and

$\epsilon$  = signal energy,

this implies that  $TP_{nj}/\epsilon = JSR$ . We have therefore that Eq. 3.39 becomes

$$\begin{aligned}
P_e &= 1 - \frac{1}{M} \sum_{i=1}^M \int_{-\infty}^{\infty} \left[ 1 - \text{erfc}_* \left( \eta + \sqrt{\frac{\text{SNR}}{0.5 + \text{JSR} \cdot \text{SNR}/M}} \right) \right]^{M-1} \frac{1}{\sqrt{2\pi}} e^{-n^2/2} dn \\
&= 1 - \int_{-\infty}^{\infty} \left[ 1 - \text{erfc}_* \left( \eta + \sqrt{\frac{\text{SNR}}{0.5 + \text{JSR} \cdot \text{SNR}/M}} \right) \right]^{M-1} \frac{1}{\sqrt{2\pi}} e^{-n^2/2} dn
\end{aligned} \tag{3.47}$$

Observe that for  $JSR = 0$ , Eq. 3.47 is identical to the well-known formula for the performance of the receiver of Fig. 3.1 under MFSK modulation.

IV. NON-COHERENT BINARY FREQUENCY SHIFT KEYED  
SIGNAL DETECTION IN THE PRESENCE OF COLORED NOISE

A. THE QUADRATURE RECEIVER, EQUIVALENT FORMS AND RECEIVER PERFORMANCE IN THE PRESENCE OF WHITE GAUSSIAN NOISE

In this section, a short presentation of the basic principles of statistical communication theory that lead to the design of the well-known quadrature receiver is undertaken. Basic results that are useful in the sequel are presented only, since the details have been worked out in numerous textbooks (see [Ref. 7] for example).

Consider a binary digital communication system model in which one of two signals,  $S_0(t)$  or  $S_1(t)$ , with energy  $E_0$  and  $E_1$ , respectively, is received in the time interval  $(0, T)$ . At the receiver, white Gaussian noise with zero mean and spectral density  $N_0/2$  is added to the signal. The actual received signal  $r(t)$  takes on one of the two forms, namely

$$r(t) = \sqrt{E_i} S_i(t) + n(t) \quad 0 \leq t \leq T, \quad i = 0, 1 \quad (4.1)$$

The likelihood ratio test which operates on  $r(t)$  in order to choose which one of the two hypotheses is believed to be the true one, namely

$$H_i: r(t) = \sqrt{E_i} S_i(t) + n(t), \quad 0 \leq t \leq T, \quad (4.2) \\ i = 0, 1$$



is

$$\Lambda(r(t)) = \frac{\exp\left\{-\frac{1}{N_0} \int_0^T [r(t) - \sqrt{E_1} S_1(t)]^2 dt\right\}}{\exp\left\{-\frac{1}{N_0} \int_0^T [r(t) - \sqrt{E_0} S_0(t)]^2 dt\right\}} \begin{matrix} > \\ < \end{matrix} \gamma \quad (4.3)$$

where  $\gamma$  is a threshold whose value depends on the decision criteria used. This test can be applied to any communication problem involving transmission of known signals  $S_0(t)$  and  $S_1(t)$ . One such example is the well-known BFSK modulation scheme.

One problem of interest, which is a slight modification of BFSK modulation problems, involves signals

$$\sqrt{E_i} S_i(t) = A \sin(\omega_i t + \phi_i) \quad \begin{matrix} i = 0, 1 \\ 0 \leq t < T \end{matrix} \quad (4.4)$$

where the phases  $\phi_i$ ,  $i = 0, 1$  are statistically independent random variables, uniformly distributed over the interval  $(0, 2\pi)$ , and the amplitudes  $A$  are known and equal. It turns out that the test specified by Eq. 4.3 can be modified to account for the random phases  $\phi_i$  by using conditional probability densities.

The details of the procedure have been worked out in Reference 8. It can be shown that when the signals are given by Eq. 4.4, the test of Eq. 4.3 becomes

$$\Lambda(r(t)) = \frac{I_0(2Aq_1/N_0)}{I_0(2Aq_0/N_0)} \quad (4.5)$$

where

$$q_k^2 = \left[ \int_0^T r(t) \sin \omega_k t dt \right]^2 + \left[ \int_0^T r(t) \cos \omega_k t dt \right]^2, \quad k = 0, 1 \quad (4.6)$$

and  $I_0(\cdot)$  is the modified Bessel function, defined by

$$I_0(x) = \sum_{n=0}^{\infty} \frac{x^{2n}}{2^{2n} (n!)^2} = \frac{1}{2\pi} \int_0^{2\pi} e^{x \cos(\theta + \alpha)} d\alpha \quad (4.7)$$

For minimum error probability decision criterion, the decision rule of Eq. 4.5 assuming equal prior probability of transmitting  $S_0(t)$  or  $S_1(t)$ , is to choose  $H_1$  if

$$I_0(2Aq_1/N_0) \geq I_0(2Aq_0/N_0) \quad (4.8)$$

or equivalently, to choose  $H_1$  if

$$q_1^2 \geq q_0^2$$

Otherwise  $H_0$  is chosen. (Observe that  $I_0(x)$  is a monotonically increasing function.)

The receiver structure that implements the test of Eq. 4.8 is shown in Fig. 4.1. Another (equivalent) form of the receiver of Fig. 4.1 is shown in Fig. 4.2, involving a combination of matched filters and the envelope detectors. The

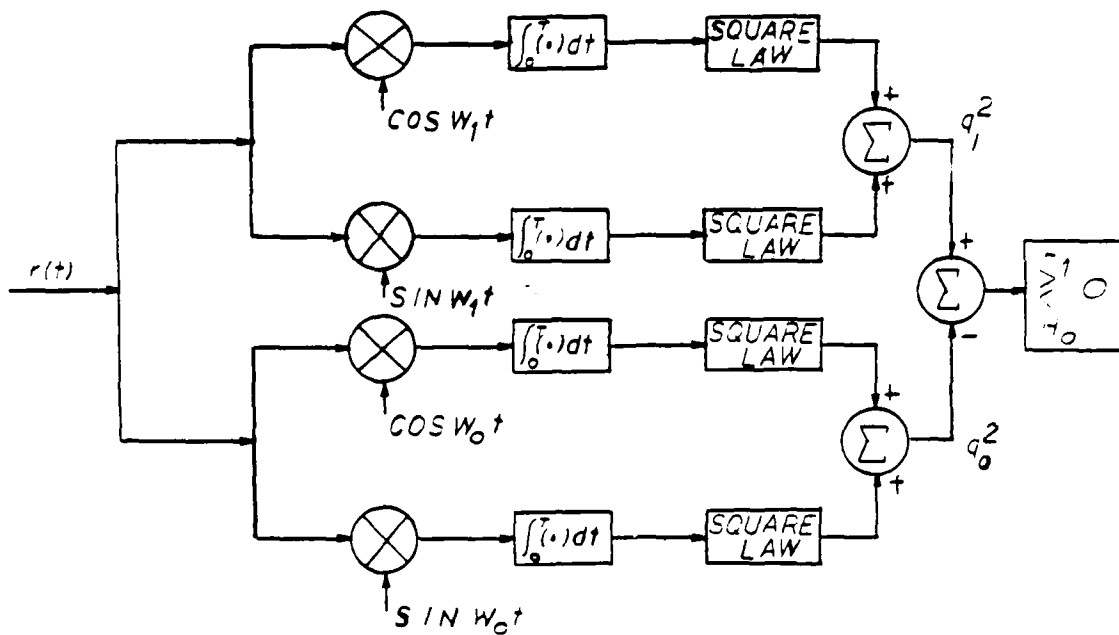

Figure 4.1. Quadrature receiver

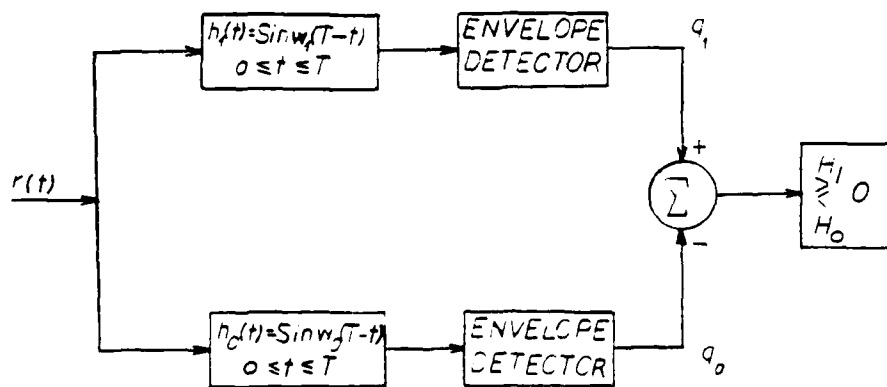

Figure 4.2. Matched filter equivalent to quadrature receiver

receiver of Fig. 4.2 is completely equivalent to the receiver of Fig. 4.1.

The evaluation of the performance of the receiver has been worked out in Reference 9 and is given by

$$P_e = \frac{1}{2} e^{-E/2N_0} \quad (4.9)$$

where  $E = A^2 T/2$  is the average signal energy. If we now define the signal to noise ratio, (SNR) as

$$\text{SNR} \triangleq E/N_0$$

we obtain the simple result

$$P_e = \frac{1}{2} \exp\{-\text{SNR}/2\} \quad (4.10)$$

#### B. RECEIVER PERFORMANCE IN THE PRESENCE OF COLORED NOISE

The receiver presented in Section A is optimum in minimum probability of error sense when operating in a white Gaussian noise interference environment. In this section we analyze the vulnerability (probability of error) of the quadrature receiver in the presence of an additional additive noise that is modeled as colored and Gaussian, having autocorrelation function  $K_c(\tau)$ . (We denote  $n_c(t)$  as this additional colored noise).

The problem can then be restated as follows. Under hypotheses  $H_i$ ,  $i = 0, 1$ ,  $r(t)$  takes on the form

$$H_i: r(t) = S_i(t) + w(t) + n_c(t) \quad i = 0,1 \quad (4.11)$$

$$0 \leq t \leq T$$

where

$$S_i(t) = \sqrt{E} S'_i(t) = A \sin(\omega_i t + \phi_i) \quad i = 0,1 \quad (4.12)$$

In order to determine the effect of  $n_c(t)$  on the receiver probability of error, we evaluate the statistics of the random variables  $q_k^2$ ,  $k = 0,1$ , where, as defined by Eq. 4.6,

$$q_k^2 = \left[ \int_0^T r(t) \sin \omega_k t dt \right]^2 + \left[ \int_0^T r(t) \cos \omega_k t dt \right]^2 \quad (4.6)$$

$$k = 0,1$$

Thus, conditioned on  $H_i$ ,  $i = 0,1$

$$q_k^2 = \left[ \int_0^T [S_i(t) + w(t) + n_c(t)] \sin \omega_k t dt \right]^2$$

$$+ \left[ \int_0^T [S_i(t) + w(t) + n_c(t)] \cos \omega_k t dt \right]^2$$

$$\equiv X_{i,k}^2 + Y_{i,k}^2 \quad i = 0,1 \quad k = 0,1 \quad (4.13)$$

Observe first that the integral

$$\begin{aligned}
\int_0^T S_i(t) \sin \omega_k t dt &= \int_0^T A \sin(\omega_i t + \phi_i) \sin \omega_k t dt \\
&= \frac{AT}{2} \left[ \frac{\sin(\omega_i - \omega_k)T/2}{(\omega_i - \omega_k)T/2} \cos[(\omega_i - \omega_k)T/2 + \phi_i] \right. \\
&\quad \left. - \frac{\sin(\omega_i + \omega_k)T/2}{(\omega_i + \omega_k)T/2} \cos[(\omega_i + \omega_k)T/2 + \phi_i] \right] \quad \begin{matrix} i = 0,1 \\ k = 0,1 \end{matrix} \quad (4.14)
\end{aligned}$$

If we now assume that

$$(\omega_1 - \omega_0)T = 2m\pi \quad \text{and} \quad (\omega_1 + \omega_0)T = 2\ell\pi \quad (4.15)$$

we have that  $\sin(\omega_i + \omega_k)T/2 = 0$ , for  $i = 0,1$ ,  $k = 0,1$ . Thus

$$\begin{aligned}
\int_0^T S_i(t) \sin \omega_k t dt &= \frac{AT}{2} \frac{\sin(\omega_i - \omega_k)T/2}{(\omega_i - \omega_k)T/2} \cos[(\omega_i - \omega_k)T/2 + \phi_i] \delta_{i,k} \quad (4.16) \\
&\quad i = 0,1 \quad k = 0,1
\end{aligned}$$

where

$$\delta_{ik} = \begin{cases} 1 & \text{if } i = k \\ 0 & \text{if } i \neq k \end{cases} \quad (4.17)$$

By arguments similar to the above,

$$\begin{aligned}
\int_0^T S_i(t) \cos \omega_k t dt &= \frac{AT}{2} \frac{\sin(\omega_i - \omega_k)T/2}{(\omega_i - \omega_k)T/2} \sin[(\omega_i - \omega_k)T/2 + \phi_i] \delta_{i,k} \quad (4.18) \\
&\quad i = 0,1 \quad k = 0,1
\end{aligned}$$

Now conditioned on  $\phi_i$ ,  $i = 0, 1$ , the  $X_{i,k}$  and  $Y_{i,k}$  are Gaussian random variables, so it is possible to obtain the conditional probability density function of  $q_k$ ,  $k = 0, 1$ . Thus

$$E\{X_{i,k}/H_i, \phi_i\} = \int_0^T S_i(t) \sin \omega_k t dt \quad i = 0, 1 \quad k = 0, 1 \quad (4.19)$$

and

$$\begin{aligned} \text{Var}\{X_{i,k}/H_i, \phi_i\} &= E\left\{\left[\int_0^T (w(t) + n_c(t)) \sin \omega_k t dt\right]^2\right\} \\ &= \int_0^T \int_0^T E\{w(t)w(\tau) + n_c(t)n_c(\tau)\} \sin \omega_k t \sin \omega_k \tau dt d\tau \\ &= \int_0^T \frac{N_0}{2} \sin^2 \omega_k t dt + \int_0^T \int_0^T K_c(t-\tau) \sin \omega_k t \sin \omega_k \tau dt d\tau \\ &\triangleq \sigma_w^2 + \sigma_{c,k}^2 \quad i = 0, 1, \quad k = 0, 1 \end{aligned} \quad (4.20)$$

where, assuming that  $2\omega_k T \gg 1$

$$\sigma_w^2 \triangleq \frac{N_0}{2} \int_0^T \sin^2 \omega_k t dt \triangleq \frac{N_0 T}{4} \quad k = 0, 1 \quad (4.21)$$

and

$$\sigma_{c,k}^2 \triangleq \int_0^T \int_0^T K_c(t-\tau) \sin \omega_k t \sin \omega_k \tau dt d\tau \quad k = 0, 1 \quad (4.22)$$

Similarly

$$E\{Y_{i,k}/H_i, \phi_i\} = \int_0^T S_i(t) \cos \omega_k t dt \quad i = 0,1 \quad k = 0,1 \quad (4.23)$$

and

$$\begin{aligned} \text{Var}(Y_{i,k}/H_i, \phi_i) &= \int_0^T \frac{N_0}{2} \cos^2 \omega_k t dt + \iint_0^T K_c(t-\tau) \cos \omega_k t \cos \omega_k \tau dt d\tau \\ &\triangleq \sigma_w^2 + \sigma_{C,k}^2 \quad k = 0,1 \quad i = 0,1 \end{aligned} \quad (4.24)$$

since it can be demonstrated that

$$\begin{aligned} \iint_0^T K_c(t-\tau) \sin \omega_k t \sin \omega_k \tau dt d\tau &= \iint_0^T K_c(t-\tau) \cos \omega_k t \cos \omega_k \tau dt d\tau \\ k &= 0,1 \end{aligned} \quad (4.25)$$

Finally

$$\begin{aligned} E\left\{ \left[ X_{i,k} - E\{X_{i,k}/H_i, \phi_i\} \right] \left[ Y_{i,k} - E\{Y_{i,k}/H_i, \phi_i\} \right] / H_i, \phi_i \right\} \\ = E \left\{ \int_0^T [w(t) + n_c(t)] \sin \omega_k t dt \int_0^T [w(\tau) + n_c(\tau)] \cos \omega_k \tau d\tau \right\} \\ = \int_0^T \frac{N_0}{2} \sin \omega_k t \cos \omega_k t dt + \iint_0^T K_c(t-\tau) \sin \omega_k t \cos \omega_k \tau dt d\tau \\ i = 0,1 \quad k = 0,1 \end{aligned} \quad (4.26)$$



It can be shown that these two integrals are zero so that  $X_{i,k}$  and  $Y_{i,k}$  are conditionally uncorrelated, and therefore independent since they are Gaussian random variables. Now define

$$q'_k \triangleq q_k^2 \quad k = 0,1 \quad (4.27)$$

and

$$\sigma_k^2 = \sigma_w^2 + \sigma_{c,k}^2 \quad k = 0,1 \quad (4.28)$$

so that the conditional density functions for  $q'_k$ ,  $k = 0,1$  are,

$$P(q'_0/H_0, \phi_0) = \frac{1}{2\sigma_0^2} \exp \left\{ -\frac{(q'_0 + \lambda'_{00})}{2\sigma_0^2} \right\} I_0 \left( \sqrt{\frac{q'_0 \lambda'_{00}}{\sigma_0^2}} \right) u(q'_0) \quad (4.29)$$

where  $u(\cdot)$  is the unit step function, and

$$\lambda'_{00} = E^2\{X_{0,0}/H_0, \phi_0\} + E^2\{Y_{0,0}/H_0, \phi_0\}$$

Using Eq. 4.16 and Eq. 4.18, we have

$$\lambda'_{00} = \left(\frac{AT}{2} \cos \phi_0\right)^2 + \left(\frac{AT}{2} \sin \phi_0\right)^2 = \left(\frac{AT}{2}\right)^2 \quad (4.30)$$

Also

$$P(q'_0/H_1, \phi_1) = \frac{1}{2\sigma_0^2} \exp \left\{ -\frac{(q'_0 + \lambda'_{01})}{2\sigma_0^2} \right\} I_0 \left( \sqrt{\frac{q'_0 \lambda'_{01}}{\sigma_0^2}} \right) u(q'_0) \quad (4.31)$$

where

$$\lambda_{1,0}' = E^2\{X_{1,0}/H_{1,0}\} + E^2\{Y_{1,0}/H_{1,0}\} = 0 \quad (4.32)$$

due to the result of Eqs. 4.16, 4.17 and 4.18 for  $i \neq k$ .

Therefore

$$P(q_0'/H_{1,0}, \phi_1) = \frac{1}{2\sigma_0^2} \exp\{-q_0'/2\sigma_0^2\} u(q_0') \quad (4.33)$$

Furthermore

$$P(q_1'/H_{0,1}, \phi_0) = \frac{1}{2\sigma_1^2} \exp\left\{-\frac{(q_1' + \lambda_{0,1}')}{2\sigma_1^2}\right\} I_0\left(\frac{\sqrt{q_1' \lambda_{0,1}'}}{\sigma_1}\right) u(q_1') \quad (4.34)$$

where again due to Eqs. 4.16, 4.17 and 4.18,

$$\lambda_{0,1}^2 = E^2\{X_{0,1}/H_{0,1}\} + E^2\{Y_{0,1}/H_{0,1}\} = 0 \quad (4.35)$$

so that

$$P(q_1'/H_{0,1}, \phi_0) = \frac{1}{2\sigma_1^2} \exp\{-q_1'/2\sigma_1^2\} u(q_1') \quad (4.36)$$

Finally

$$P(q_1'/H_{1,1}, \phi_1) = \frac{1}{2\sigma_1^2} \exp\left\{-\frac{(q_1' + \lambda_{1,1}')}{2\sigma_1^2}\right\} I_0\left(\frac{\sqrt{q_1' \lambda_{1,1}'}}{\sigma_1}\right) u(q_1') \quad (4.37)$$

$$\lambda_{11}^{-1} = E^2\{x_{11}/H_1\phi_1\} + E^2\{y_{11}/H_1\phi_1\} = \left(\frac{AT}{2}\right)^2 \quad (4.38)$$

We now have the statistical information needed to compute the probability of receiver error  $P_e$ . Assuming that each hypothesis has equal prior probability, we have

$$P_e = \frac{1}{2} P\{q_1 - q_0 > 0/H_0\} + \frac{1}{2} P\{q_1 - q_0 < 0/H_1\} \quad (4.39)$$

Observe that

$$P\{q_1 - q_0 > 0/H_0\} = \int_{-\infty}^{\infty} P\{q_1 > q_0/H_0, q_0 = \rho\} P_{q_0}(\rho/H_0) d\rho \quad (4.40)$$

where

$$P\{q_1 > q_0/H_0, q_0 = \rho\} = \int_0^{\infty} P(q_1/H_0) dq_1 \quad (4.41)$$

Since the conditional probabilities functions are not dependent on the individual phases, that is

$$P(q_1/H_i) = P(q_1/H_i, \phi_i) \quad i = 0, 1 \quad (4.42)$$

and

$$P(q_0/H_i) = P(q_0/H_i, \phi_i) \quad i = 0, 1 \quad (4.43)$$

we can rewrite the conditional probability functions in the following form

$$\begin{aligned}
 P(q_0/H_0, \phi_0) &= 2q_0 P(q_0^2/H_0, \phi_0) \\
 &= \frac{q_0}{\sigma_0^2} \exp \left\{ - \frac{((AT/2)^2 + q_0^2)}{2\sigma_0^2} \right\} I_0 \left( \frac{q_0 (AT/2)}{\sigma_0^2} \right) u(q_0) \quad (4.44)
 \end{aligned}$$

$$\begin{aligned}
 P(q_0/H_1, \phi_1) &= 2q_0 P(q_0^2/H_1, \phi_1) \\
 &= \frac{q_0}{\sigma_0^2} \exp \left\{ - \frac{q_0^2}{2\sigma_0^2} \right\} u(q_0) \quad (4.45)
 \end{aligned}$$

$$\begin{aligned}
 P(q_1/H_0, \phi_0) &= 2q_1 P(q_1^2/H_0, \phi_0) \\
 &= \frac{q_1}{\sigma_1^2} \exp \left\{ - \frac{q_1^2}{2\sigma_1^2} \right\} u(q_1) \quad (4.46)
 \end{aligned}$$

$$\begin{aligned}
 P(q_1/H_1, \phi_1) &= 2q_1 P(q_1^2/H_1, \phi_1) \\
 &= \frac{q_1}{\sigma_1^2} \exp \left\{ - \frac{((AT/2)^2 + q_1^2)}{2\sigma_1^2} \right\} I_0 \left( \frac{q_1 (AT/2)}{\sigma_1^2} \right) u(q_1) \quad (4.47)
 \end{aligned}$$

Thus

$$P\{q_1 - q_0 > 0/H_0\} = \int_{-\infty}^{\infty} \left[ \int_0^{\infty} P(q_1/H_0) dq_1 \right] P_{q_0}(0/H_0) dc \quad (4.48)$$

Similarly

$$P\{q_1 - q_0 < 0/H_1\} = \int_{-\infty}^{\infty} P\{q_1 < q_0/H_1, q_0 = \rho\} P_{q_0}(\rho/H_1) d\rho \quad (4.49)$$

where

$$P\{q_1 < q_0/H_1, q_0 = \rho\} = \int_{-\infty}^{\rho} P(q_1/H_1) dq_1 \quad (4.50)$$

so that

$$P\{q_1 - q_0 < 0/H_1\} = \int_{-\infty}^{\infty} \left[ \int_{-\infty}^{\rho} P(q_1/H_1) dq_1 \right] P_{q_0}(\rho/H_1) d\rho \quad (4.51)$$

Using now Eq. 4.44 and Eq. 4.46 we have

$$\begin{aligned} P\{q_1 - q_0 > 0/H_0\} &= \int_{-\infty}^{\infty} \left[ \int_{\rho}^{\infty} \frac{q_1}{\sigma_1} \exp\{-q_1^2/2\sigma_1^2\} u(q_1) dq_1 \right] P_{q_0}(\rho/H_0) d\rho \\ &= \int_{-\infty}^{\infty} \exp\{\rho^2/2\sigma_1^2\} \frac{\rho}{\sigma_0} \exp\left\{-\frac{((AT/2)^2 + \rho^2)}{2\sigma_0^2}\right\} I_0\left(\frac{\rho(AT/2)}{\sigma_0^2}\right) u(\rho) d\rho \end{aligned} \quad (4.52)$$

For convenience, let  $\varepsilon = AT/2$  and, recalling  $u(\rho) = 1, \rho > 0$

Eq. 4.52 becomes

$$P\{q_1 - q_0 > 0/H_0\} = \int_0^{\infty} \exp\left\{-\rho^2\left(\frac{1}{2\sigma_1^2} + \frac{1}{2\sigma_0^2}\right)\right\} \frac{\rho}{\sigma_0^2} \exp\left\{-\varepsilon^2/2\sigma_0^2\right\} I_0\left(\frac{\rho\varepsilon}{\sigma_0^2}\right) d\rho \quad (4.53)$$

Letting

$$\frac{1}{2\sigma_T^2} = \frac{1}{2\sigma_1^2} + \frac{1}{2\sigma_0^2} = \frac{\sigma_0^2 + \sigma_1^2}{2\sigma_0^2\sigma_1^2} \quad (4.54)$$

so that

$$\sigma_T^2 = \sigma_0^2\sigma_1^2/(\sigma_0^2 + \sigma_1^2) \quad (4.55)$$

we have

$$\begin{aligned} P\{q_1 - q_0 > 0/H_0\} &= \int_0^{\infty} \exp\{-\rho^2/2\sigma_T^2\} \frac{\sigma_T^2}{\sigma_0^2} \frac{\rho}{\sigma_T^2} e^{-\varepsilon^2/2\sigma_0^2} I_0\left(\frac{\rho}{\sigma_T} \frac{\varepsilon\sigma_T^2}{\sigma_0^2}\right) d\rho \\ &= \frac{\sigma_T^2}{\sigma_0^2} e^{-\varepsilon^2/2\sigma_0^2} e^{\alpha_0^2/2\sigma_T^2} \int_0^{\infty} \frac{\rho}{\sigma_T^2} e^{-(\rho^2 + \alpha_0^2)/2\sigma_T^2} I_0\left(\frac{\rho\alpha_0}{\sigma_T}\right) d\rho \end{aligned} \quad (4.56)$$

where

$$\alpha_0 = \varepsilon\sigma_T^2/\sigma_0^2 \quad (4.57)$$

Now the integral itself yields 1, since it is the integral of a probability density function. Therefore

$$\begin{aligned}
P(q_1 - q_0 > 0/H_0) &= \frac{\sigma_T^2}{\sigma_0^2} \exp \left\{ -\frac{\epsilon^2}{2\sigma_0^2} + \frac{\epsilon^2 \sigma_T^2 / \sigma_0^2}{2\sigma_T^2} \right\} \\
&= \frac{\sigma_T^2}{\sigma_0^2} \exp \left\{ -\frac{\epsilon^2}{2\sigma_0^2} \left[ 1 - \frac{\sigma_T^2}{\sigma_0^2} \right] \right\}
\end{aligned} \tag{4.58}$$

Similarly for Eq. 4.51

$$\begin{aligned}
P(q_1 - q_0 < 0/H_1) &= \int_{-\infty}^{\infty} \left[ \int_{-\infty}^{\rho} \frac{q_1}{\sigma_1^2} e^{-((AT/2)^2 + q_1^2)/2\sigma_1^2} I_0 \left( \frac{q_1 (AT/2)}{\sigma_1^2} \right) \right. \\
&\quad \left. u(q_1) dq_1 \right] P_{q_0}(\rho/H_1) d\rho
\end{aligned} \tag{4.59}$$

Observing first, the quantity in brackets can be expressed as

$$\begin{aligned}
&\int_{-\infty}^{\rho} \frac{q_1}{\sigma_1^2} e^{-((AT/2)^2 + q_1^2)/2\sigma_1^2} I_0 \left( \frac{q_1 (AT/2)}{\sigma_1^2} \right) u(q_1) dq_1 \\
&= 1 - \int_{\rho}^{\infty} \frac{q_1}{\sigma_1^2} e^{-((AT/2)^2 + q_1^2)/2\sigma_1^2} I_0 \left( \frac{q_1 (AT/2)}{\sigma_1^2} \right) u(q_1) dq_1
\end{aligned} \tag{4.60}$$

Letting

$$\alpha_1 = AT/2\sigma_1 \tag{4.61}$$

and making a change of variable

$$x = q_1/\sigma_1 \tag{4.62}$$

we have that Eq. 4.60 becomes

$$1 - \int_{\rho/\sigma_1}^{\infty} x e^{-(x^2 + \alpha_1^2)/2} I_0(\alpha_1 x) u(x) dx = 1 - Q(\alpha_1, \rho/\sigma_1) \quad (4.63)$$

where  $Q(\cdot, \cdot)$  is the well-known Marcum Q function [Ref. 10].

Therefore Eq. 4.59 becomes

$$\begin{aligned} P\{q_1 - q_0 < 0/H_1\} &= \int_{-\infty}^{\infty} \left[ 1 - Q\left(\frac{AT/2}{\sigma_1}, \frac{\rho}{\sigma_1}\right) \right] \frac{\rho}{\sigma_0^2} e^{-\rho^2/2\sigma_0^2} u(\rho) d\rho \\ &= 1 - \int_0^{\infty} Q\left(\frac{AT/2}{\sigma_1}, \frac{\rho}{\sigma_1}\right) \frac{\rho}{\sigma_0^2} e^{-\rho^2/2\sigma_0^2} d\rho \end{aligned} \quad (4.64)$$

From Reference 11, the integral of Eq. 4.64 becomes

$$\begin{aligned} \int_0^{\infty} Q\left(\frac{AT/2}{\sigma_1}, \frac{\rho}{\sigma_1}\right) \frac{\rho}{\sigma_0^2} e^{-\rho^2/2\sigma_0^2} d\rho &= \frac{\sigma_0^2}{\sigma_0^2 + \sigma_1^2} \left[ 1 - Q\left(0, \sqrt{\frac{(AT/2)^2}{\sigma_0^2 + \sigma_1^2}}\right) \right] \\ &\quad + \frac{\sigma_1^2}{\sigma_0^2 + \sigma_1^2} Q\left(\sqrt{\frac{(AT/2)^2}{\sigma_0^2 + \sigma_1^2}}, 0\right) \\ &= \frac{\sigma_0^2}{\sigma_0^2 + \sigma_1^2} \left[ 1 - \exp\left\{-\frac{(AT/2)^2}{2(\sigma_0^2 + \sigma_1^2)}\right\} \right] + \frac{\sigma_1^2}{\sigma_0^2 + \sigma_1^2} \\ &= 1 - \frac{\sigma_0^2}{\sigma_0^2 + \sigma_1^2} \exp\left\{-\frac{(AT/2)^2}{2(\sigma_0^2 + \sigma_1^2)}\right\} \end{aligned} \quad (4.65)$$



Thus Eq. 4.59 becomes

$$P\{q_1 - q_0 < 0/H_1\} = \frac{\sigma_o^2}{\sigma_o^2 + \sigma_1^2} \exp \left\{ - \frac{(AT/2)^2}{2(\sigma_o^2 + \sigma_1^2)} \right\} \quad (4.66)$$

Now using Eq. 4.58 and Eq. 4.59 in Eq. 4.39, we have that

$$P_e = \frac{1}{2} \frac{\sigma_T^2}{\sigma_2^2} \exp \left\{ - \frac{(AT/2)^2}{2\sigma_o^2} \left[ 1 - \frac{\sigma_T^2}{\sigma_o^2} \right] \right\} + \frac{1}{2} \frac{\sigma_o^2}{\sigma_o^2 + \sigma_1^2} \exp \left\{ - \frac{(AT/2)^2}{2(\sigma_o^2 + \sigma_1^2)} \right\}$$

Recalling that  $\epsilon = AT/2$ , using Eq. 4.55, we have

$$P_e = \frac{1}{2} \exp \left\{ - \frac{\epsilon^2}{2(\sigma_o^2 + \sigma_1^2)} \right\} \quad (4.67)$$

From Eq. 4.67 it is clear that in order to minimize  $P_e$ , we must maximize  $\sigma_o^2 + \sigma_1^2$  subject to some constraint on the colored noise power. By Eq. 4.20

$$\begin{aligned} \sigma_o^2 + \sigma_1^2 &= \sigma_w^2 + \sigma_{c,o}^2 + \sigma_w^2 + \sigma_{c,1}^2 \\ &= 2\sigma_w^2 + \sigma_{c,o}^2 + \sigma_{c,1}^2 \end{aligned} \quad (4.68)$$

where

$$\begin{aligned} \sigma_{c,0}^2 + \sigma_{c,1}^2 &= \int_0^T \int_0^T K_c(t-\tau) \cos \omega_0 t + \cos \omega_0 \tau \, dt \, d\tau \\ &+ \int_0^T \int_0^T K_c(t-\tau) \cos \omega_1 t \cos \omega_1 \tau \, dt \, d\tau \end{aligned} \quad (4.69)$$

As an example, consider the case where the power spectral density of the jammer is

$$S_c(\omega) = \pi P_c [\delta(\omega - \omega_j) + \delta(\omega + \omega_j)] .$$

Under this assumption it has been shown in Appendix C, that Eq. 4.69 becomes

$$\sigma_{c,0}^2 + \sigma_{c,1}^2 = \frac{P_c T^2}{4} \left[ \left( \frac{\sin(\omega_0 - \omega_j) T/2}{(\omega_0 - \omega_j) T/2} \right)^2 + \left( \frac{\sin(\omega_1 - \omega_j) T/2}{(\omega_1 - \omega_j) T/2} \right)^2 \right] . \quad (4.70)$$

where  $\omega_j$  and  $P_c$  are the frequency and the power of the jamming waveform, respectively. It has also been demonstrated in Appendix C that Eq. 4.70 is maximum at  $\omega_j = \omega_0$  or  $\omega_j = \omega_1$ , so that

$$\left( \sigma_{c,0}^2 + \sigma_{c,1}^2 \right)_{\max} = \frac{P_c T^2}{4} \left[ \left( \frac{\sin(\omega_1 - \omega_0) T/2}{(\omega_1 - \omega_0) T/2} \right)^2 + 1 \right] \quad (4.71)$$

and Eq. 4.68 now becomes

$$\sigma_0^2 + \sigma_1^2 = 2 \frac{N_0 T}{4} + \frac{P_c T^2}{4} \left[ \left( \frac{\sin(\omega_1 - \omega_0) T/2}{(\omega_1 - \omega_0) T/2} \right)^2 + 1 \right] \quad (4.72)$$

Thus Eq. 4.67 becomes

$$\begin{aligned} P_e &= \frac{1}{2} \exp \left\{ \frac{-A^2 T^2 / 4}{N_0 T + \frac{P_c T^2}{2} \left[ 1 + \left( \frac{\sin(\omega_1 - \omega_0) T/2}{(\omega_1 - \omega_0) T/2} \right)^2 \right]} \right\} \\ &= \frac{1}{2} \exp \left\{ \frac{A^2 T / 4 N_0}{1 + \frac{P_c T^2}{2 N_0} \left[ 1 + \left( \frac{\sin(\omega_1 - \omega_0) T/2}{(\omega_1 - \omega_0) T/2} \right)^2 \right]} \right\} \\ P_e &= \frac{1}{2} \exp \left\{ \frac{-\text{SNR}}{2 + \text{JSR} \cdot \text{SNR} \left[ 1 + \left( \frac{\sin(\omega_1 - \omega_0) T/2}{(\omega_1 - \omega_0) T/2} \right)^2 \right]} \right\} \quad (4.73) \end{aligned}$$

where  $\text{SNR} = (A^2 T/2)/N_0$  and  $\text{JSR} = P_c T/(A^2 T/2)$ , represent signal to noise ratio and jamming to signal ratio respectively.

Observe that with  $\text{JSR} = 0$ , Eq. 4.73 becomes identical to Eq. 4.10. This result is appealing because for the case of no jamming, the receiver performance should be identical to that of a receiver operating in white Gaussian noise interference only.

### C. RECEIVER PERFORMANCE IN THE PRESENCE OF WHITE GAUSSIAN NOISE UNDER SINGLE CHANNEL OPERATION

In Section B, we have analyzed the performance of the quadrature receiver in the presence of white and colored Gaussian noise. Results were specifically obtained when the colored noise interference was a single frequency jammer. Suppose now that the quadrature receiver experiences a single frequency interference which corresponds to one of the signal frequencies, say  $\omega_0$ . Since the receiver makes binary decisions based on whether  $q_1 > q_0$  or vice versa, the presence of the interference at frequency  $\omega_0$  will cause  $q_0$  to be greater than  $q_1$  most of the time creating decision errors nearly 50% of the time.

In order to prevent this type of situation from arising, the receiver can turn off the affected channel, or equivalently, make decisions based only on the output of the other channel, that is, based only on the size of  $q_1$ . In this section the performance of the quadrature receiver is analyzed assuming white Gaussian noise only interference, and that decisions based on only one channel output are made.

Assuming that the receiver bases decisions only on the size of  $q_1$ , the decision rule now becomes

$$\begin{array}{c} H_1 \\ > \\ q_1 < \\ < \\ H_0 \end{array} \quad (4.74)$$

Recall from Eq. 4.6 that,

$$q_k^2 = \left[ \int_0^T r(t) \sin \omega_k t dt \right]^2 + \left[ \int_0^T r(t) \cos \omega_k t dt \right]^2 \quad (4.6)$$

$$k = 0, 1$$

$$\triangleq X_k^2 + Y_k^2 \quad (4.75)$$

The probability of error is

$$P_e = P\{q_1 > \gamma/H_0\}P\{H_0\} + P\{q_1 < \gamma/H_1\}P\{H_1\} \quad (4.76)$$

and assuming that  $P\{H_0\} = P\{H_1\} = 1/2$  then Eq. 4.76 becomes

$$P_e = \frac{1}{2} P\{q_1 > \gamma/H_0\} + \frac{1}{2} P\{q_1 < \gamma/H_1\} \quad (4.77)$$

The information bearing signals are

$$\sqrt{E_i} S_i(t) = A \sin(\omega_i t + \phi_i) \quad i = 0, 1 \quad (4.4)$$

$$0 \leq t \leq T$$

and in Section B we found that

$$P(q_1/H_0) = \frac{q_1}{\sigma_1} e^{-q_1^2/2\sigma_1^2} u(q_1) \quad (4.46)$$

and

$$P(q_1/H_1) = \frac{q_1}{\sigma_1} e^{-(s^2 + q_1^2)/2\sigma_1^2} I_0\left(\frac{q_1 s}{\sigma_1}\right) u(q_1) \quad (4.47)$$

where  $\epsilon = AT/2$  and

$$\sigma_1^2 = \sigma_w^2 = \frac{N_0 T}{4} \quad (4.21)$$

Thus, from Eqs. 4.19, 4.46, and 4.47, we obtain

$$P_e = \frac{1}{2} \int_{\gamma}^{\infty} \frac{q_1}{\sigma_1^2} e^{-q_1^2/2\sigma_1^2} u(q_1) dq_1 + \frac{1}{2} \int_{-\infty}^{\gamma} \frac{q_1}{\sigma_1^2} e^{-(\epsilon^2 + q_1^2)/2\sigma_1^2} I_0\left(\frac{q_1 \epsilon}{\sigma_1^2}\right) u(q_1) dq_1 \quad (4.78)$$

Observe however that a threshold of  $\gamma$  must now be defined. Clearly, a threshold that minimizes  $P_e$  should be chosen. This can be done by solving  $dP_e/d\gamma = 0$ .

Thus

$$\begin{aligned} \frac{dP_e}{d\gamma} &= \frac{1}{2} \left[ -\frac{1}{\sigma_1^2} e^{-\gamma^2/2\sigma_1^2} u(\gamma) + \frac{1}{\sigma_1^2} e^{-(\epsilon^2 + \gamma^2)/2\sigma_1^2} I_0\left(\frac{\gamma \epsilon}{\sigma_1^2}\right) u(\gamma) \right] \\ &= \frac{1}{2} \frac{1}{\sigma_1^2} e^{-\gamma^2/2\sigma_1^2} u(\gamma) \left[ -1 + e^{-\epsilon^2/2\sigma_1^2} I_0\left(\frac{\gamma \epsilon}{\sigma_1^2}\right) \right] \end{aligned} \quad (4.79)$$

so that solution of  $dP_e/d\gamma = 0$  yields an implicit solution for  $\gamma$ , namely,

$$I_0\left(\frac{\gamma \epsilon}{\sigma_1^2}\right) = e^{\epsilon^2/2\sigma_1^2} \quad (4.80)$$

Suppose now that  $\gamma_0$  is the solution of Eq. 4.80 for a given value of  $\epsilon$  and  $\sigma_1^2$ . Then

$$P_e = \frac{1}{2} \int_{\eta_0}^{\infty} \frac{q_1}{\sigma_1} e^{-q_1^2/2\sigma_1^2} u(q_1) dq_1 + \frac{1}{2} \int_{-\infty}^{\gamma_0} \frac{q_1}{\sigma_1} e^{-(\epsilon^2+q_1^2)/2\sigma_1^2} I_0\left(\frac{q_1 \epsilon}{\sigma_1^2}\right) u(q_1) dq_1 \quad (4.81)$$

Letting  $y = q_1/\sigma_1$ , Eq. 4.81 becomes

$$P_e = \frac{1}{2} e^{-\gamma_0^2/2\sigma_1^2} + \frac{1}{2} \left[ 1 - \int_{\gamma_0/\sigma_1}^{\infty} y e^{-\frac{1}{2}\left(\left(\frac{\epsilon}{\sigma_1}\right)^2 + y^2\right)} I_0\left(y\left(\frac{\epsilon}{\sigma_1}\right)\right) dy \right] = \frac{1}{2} + \frac{1}{2} e^{-\gamma_0^2/2\sigma_1^2} - \frac{1}{2} Q(\epsilon/\sigma_1, \eta_0/\sigma_1) \quad (4.82)$$

Observe that

$$\frac{\epsilon^2}{2\sigma_1^2} = \frac{(AT/2)^2}{2N_0 T/4} = \frac{A^2 T}{2N_0} = \text{SNR} \quad (4.83)$$

so that defining

$$\gamma_{TH} = \gamma_o / \epsilon \quad (4.84)$$

we have

$$\frac{\gamma_o}{\sigma_1} = \frac{\gamma_{TH} \epsilon}{\sigma_1} = \gamma_{TH} \sqrt{2SNR} \quad (4.85)$$

so that the threshold setting equation (Eq. 4.80) becomes

$$I_o(\gamma_{TH}(2SNR)) = e^{-SNR} \quad (4.86)$$

and Eq. 4.82 simplifies to

$$P_e = \frac{1}{2} + \frac{1}{2} \exp\left\{-\frac{1}{2} \frac{2}{\gamma_{TH}}(2SNR)\right\} - \frac{1}{2} Q(\sqrt{2SNR}, \gamma_{TH}(\sqrt{2SNR})) \quad (4.87)$$

The receiver performance indicated by Eq. 4.87 is compared to that of an incoherent BFSK receiver that utilizes both channels for its decisions. (See. Eq. 4.10.) The result of this comparison is presented in Chapter V.

#### D. RECEIVER PERFORMANCE IN THE PRESENCE OF COLORED NOISE UNDER SINGLE CHANNEL OPERATION

In this section, we analyze the performance of the quadrature receiver under the assumption of single channel operation, as described in the previous section. Here however, it is additionally assumed that a jamming signal is present, whose energy is concentrated around the frequency  $\omega_o$ . (Observe that



the channel whose output is  $q_0$  has a passband around  $\omega_0$ . Thus a jammer concentrating its energy around  $\omega_0$  would significantly affect the output  $q_0$ . Consequently, turning off or ignoring  $q_0$  would make sense under these circumstances. Hence, the single channel operation being considered here.)

Our decision rule continues to be

$$q_1 \begin{matrix} H_1 \\ > \\ < \\ H_0 \end{matrix} \gamma \quad (4.74)$$

and

$$P_e = \frac{1}{2}P \{q_1 > \gamma/H_0\} + \frac{1}{2}P \{q_1 < \gamma/H_1\} \quad (4.77)$$

Observe that due to the presence of a jammer

$$\sigma_1^2 = \sigma_w^2 + \sigma_{c,1}^2 \quad (4.28)$$

where

$$\sigma_{c,1}^2 = \int_0^T \int_0^T K_c(t-\tau) \sin \omega_1 t \sin \omega_1 \tau dt d\tau \quad (4.20)$$

As shown in Appendix C,

$$\sigma_{c,1}^2 = \frac{P_c T^2}{4} \left( \frac{\sin(\omega_j - \omega_1)T/2}{(\omega_j - \omega_1)T/2} \right)^2 \quad (C.12)$$

when the jammer is concentrated at frequency  $\omega_j$ . With  $\omega_j = \omega_o$ , Eq. C.12 becomes

$$\sigma_{c,1}^2 = \frac{P_c T^2}{4} \left[ \frac{\sin(\omega_o - \omega_1) T/2}{(\omega_o - \omega_1) T/2} \right]^2 \quad (4.88)$$

so that the probability of error is

$$P_e = \frac{1}{2} + \frac{1}{2} \exp \left\{ -\frac{1}{2} \gamma_{TH}^2 \left[ \frac{\epsilon^2}{\sigma_w^2 + \sigma_{c,1}^2} \right] \right\} - \frac{1}{2} Q \left( \sqrt{\frac{\epsilon^2}{\sigma_w^2 + \sigma_{c,1}^2}} \cdot \gamma_{TH} \sqrt{\frac{\epsilon^2}{\sigma_w^2 + \sigma_{c,1}^2}} \right) \quad (4.89)$$

Observe that

$$\begin{aligned} \frac{\epsilon^2}{\sigma_w^2 + \sigma_{c,1}^2} &= \frac{A^2 T/2 N_o}{\frac{1}{2} + \frac{1}{2} \frac{P_c T}{A^2 T/2} \cdot \frac{A^2 T/2}{N_o} \left[ \frac{\sin(\omega_o - \omega_1) T/2}{(\omega_o - \omega_1) T/2} \right]^2} \\ &= \frac{2SNR}{1 + JSR \cdot SNR \left[ \frac{\sin(\omega_o - \omega_1) T/2}{(\omega_o - \omega_1) T/2} \right]^2} \end{aligned} \quad (4.90)$$

Defining

$$SSQ = \left[ \frac{\sin(\omega_o - \omega_1) T/2}{(\omega_o - \omega_1) T/2} \right]^2 \quad (4.91)$$

we have

$$P_e = \frac{1}{2} + \frac{1}{2} \exp \left\{ -\frac{1}{2} \gamma_{TH}^2 \left( \frac{2SNR}{1+JSR \cdot SNR \cdot SSQ} \right) \right\} \\ - \frac{1}{2} Q \left( \sqrt{\frac{2SNR}{1+JSR \cdot SNR \cdot SSQ}} \cdot \gamma_{TH} \sqrt{\frac{2SNR}{1+JSR \cdot SNR \cdot SSQ}} \right) \quad (4.92)$$

Observe that with JSR = 0, Eq. 4.92 becomes identical to Eq. 4.87, as must be the case.

Furthermore if the frequency separation  $(\omega_0 - \omega_1)$  is such that  $(\omega_0 - \omega_1)T/2 \gg 1$  or  $(\omega_0 - \omega_1)T/2 = m\pi$ , where  $m$  is an integer then, SSQ becomes very small or zero so that the effect of the presence of the jamming is negligible. The numerical results obtained from Eq. 4.92 are very similar to those obtained from Eq. 4.87 as demonstrated in greater detail in Chapter V.

Recall that the threshold is obtained from the solution of Eq. 4.86, namely

$$I_o(\gamma_{TH}(2SNR)) = e^{SNR} \quad (4.86)$$

However if our goal is to set a threshold that minimizes  $P_e$ , for the case being considered here, we can solve for an optimum threshold setting by minimizing Eq. 4.92 with respect to  $\gamma_{TH}$ . If this procedure is carried out, we obtain the threshold setting equation

$$I_o \left( \gamma_{TH} \left( \frac{2SNR}{1+JSR \cdot SNR \cdot SSQ} \right) \right) = \exp \left\{ \frac{SNR}{1+JSR \cdot SNR \cdot SSQ} \right\} \quad (4.93)$$

While this result is intuitively appealing, a practical problem arises in that in most cases, the receiver does not know the operating JSR value, hence a threshold could not be set.

Fortunately, computer evaluations carried out using both Eq. 4.86 and Eq. 4.93 to set the threshold have demonstrated that the  $P_e$  resulting with thresholds set by Eqs. 4.86 and 4.93 are almost (and for all practical purposes) identical.

## V. GRAPHICAL RESULTS

### A. GRAPHICAL RESULTS FOR COLORED NOISE INTERFERENCE IN COHERENT M-ARY FREQUENCY SHIFT KEYED MODULATED SYSTEMS

In Chapter III, the performance of the MFSK receiver in the presence of white and colored noise was derived. This mathematical result is used now to evaluate and graphically display receiver performance under the presence of white noise only and under the presence of white and colored noise interference.

Results are presented sequentially for values of  $M = 2, 4, 8,$  and  $16$  on the performance of the M-ary FSK receiver for white noise as the only source of interference as well as for various conditions of colored noise powers in addition to the normally present WGN interference. The performance results for the M-ary FSK receiver presented in this section in terms of the probability of error are shown as the SNR changes for specified values of JSR. Some representative results are summarized in Tables 5.1, 5.2, 5.3 and 5.4. Figures 5.1 through 5.4 include the performance of the M-ary FSK receiver when the transmitted signal is interfered by white noise only, namely,  $JSR = 0$ . This makes it possible to evaluate the effect of the jamming on the receiver in comparison to the case in which WGN is the only source of interference. These results have been obtained by evaluating Eq. 3.47.

TABLE 5.1  
PERFORMANCE OF 2-FSK RECEIVER

The Receiver	$P_e$ SNR (DB)				
	-10.0	-5.0	0.0	5.0	10.0
JSR = 0	0.3759	0.2869	0.1586	0.0376	0.0008
JSR = 0 db	0.3815	0.3120	0.2397	0.1917	0.1702
JSR = 5 db	0.3914	0.3454	0.3120	0.2959	0.2899
JSR = 10 db	0.4115	0.3914	0.3815	0.3778	0.3765
JSR = 15 db	0.4384	0.4327	0.4305	0.4298	0.4295

TABLE 5.2

## PERFORMANCE OF 4-FSK RECEIVER

The Receiver	$P_e$ SNR (DB)				
	-10.0	-5.0	0.0	5.0	10.0
JSR = 0	0.6223	0.5132	0.3222	0.0915	0.0022
JSR = 0 db	0.6262	0.5313	0.3995	0.2804	0.2153
JSR = 5 db	0.6326	0.5598	0.4861	0.4395	0.4194
JSR = 10 db	0.6478	0.6082	0.5825	0.5712	0.5671
JSR = 15 db	0.6734	0.6598	0.6538	0.6517	0.6510

TABLE 5.3  
PERFORMANCE OF 8-FSK RECEIVER

THE RECEIVER	$P_e$ SNR (DB)				
	-10.0	-5.0	0.0	5.0	10.0
JSR = 0	0.7778	0.6794	0.4755	0.1617	0.0048
JSR = 0 db	0.7792	0.6885	0.5261	0.3246	0.1885
JSR = 5 db	0.7820	0.7047	0.5958	0.4992	0.4471
JSR = 10 db	0.7894	0.7384	0.6914	0.6648	0.6540
JSR = 15 db	0.8056	0.7834	0.7709	0.7658	0.7641



TABLE 5.4  
PERFORMANCE OF 16-FSK RECEIVER

THE RECEIVER	$P_e$ SNR (DB)				
	-10.0	-5.0	0.0	5.0	10.0
JSR = 0	0.8715	0.7949	0.6083	0.2455	0.0093
JSR = 0 db	0.8720	0.7987	0.6354	0.3621	0.1374
JSR = 5 db	0.8731	0.8062	0.6796	0.5174	0.4019
JSR = 10 db	0.8763	0.8243	0.7556	0.7000	0.6733
JSR = 15 db	0.8839	0.8553	0.8329	0.8217	0.8175

# MFSK (M=2)

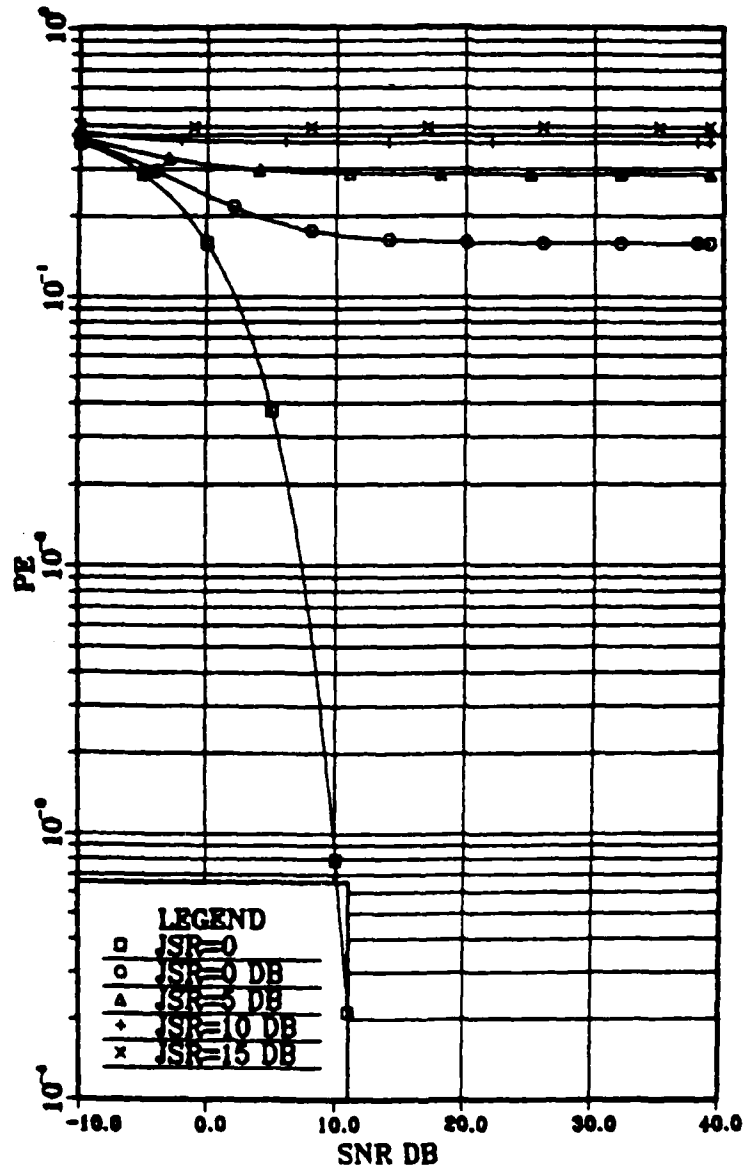

Figure 5.1. Performance of M-ary FSK for M = 2

# MFSK (M=4)

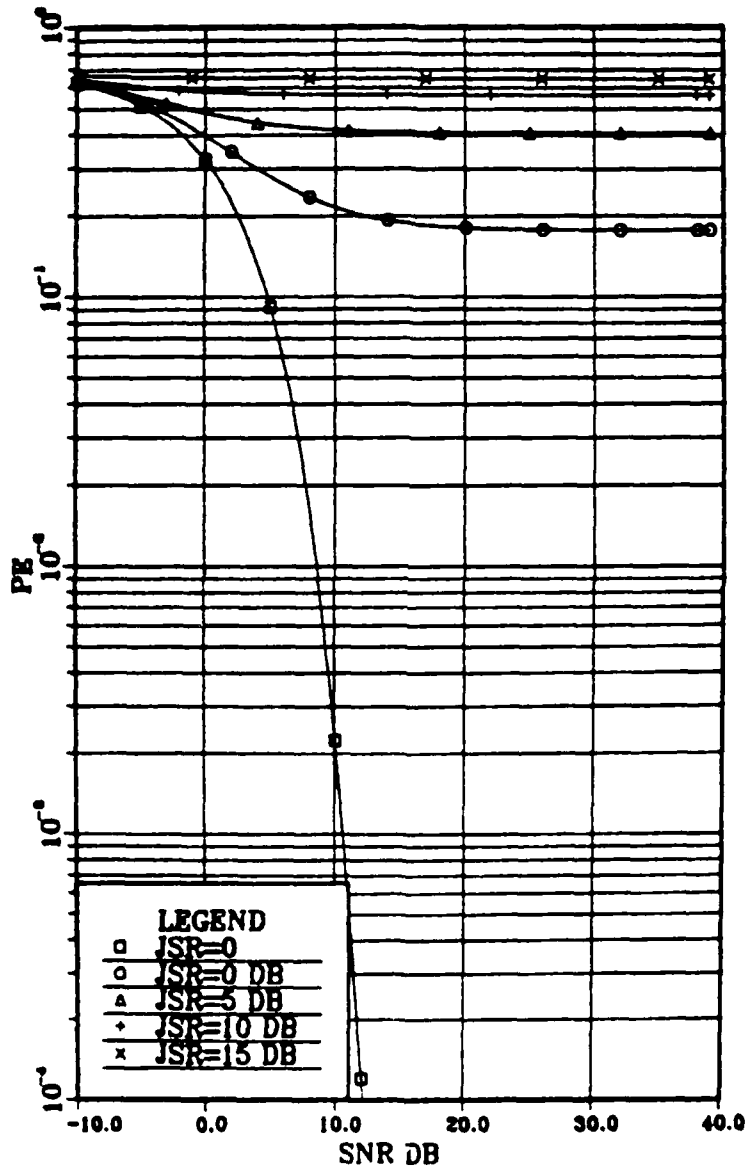

Figure 3.2. Performance of M-ary FSK for M = 4

# MFSK (M=8)

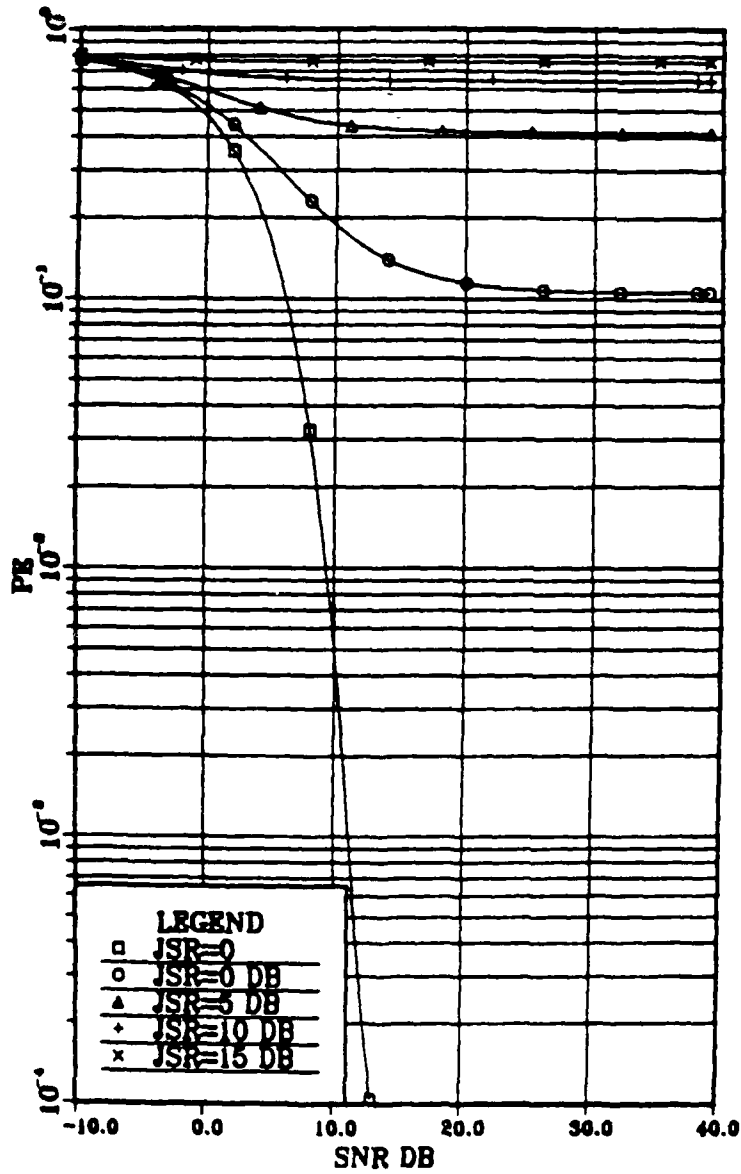

Figure 5.3. Performance of M-ary FSK for M = 8

# MFSK (M=16)

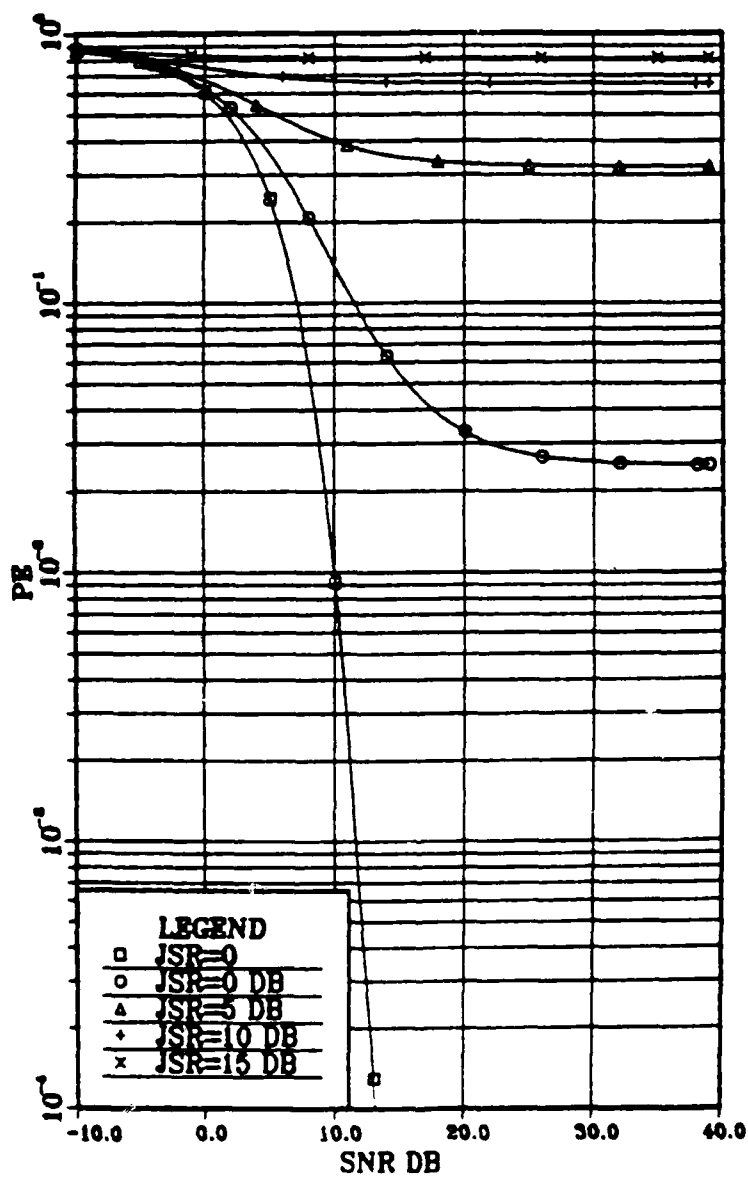

Figure 5.4. Performance of M-ary FSK for M = 16

B. GRAPHICAL RESULTS FOR NON-COHERENT BINARY FREQUENCY  
SHIFT KEYED SIGNAL DETECTION IN THE PRESENCE OF  
COLORED NOISE

In Chapter IV, the performance of the quadrature receiver operating in the presence of white and colored noise was derived. The mathematical results are now used to evaluate and graphically display receiver performance under various conditions of signal and noise powers.

First, results are presented for the case in which white noise is the only source of interference. This yields the well-known probability of error curves for the standard quadrature receiver for non-coherent BFSK. These are presented in Fig. 5.5, along with a corresponding plot of the probability of error of the quadrature receiver in which only one channel output is used to make binary decisions.

Additionally, the performance of the quadrature receiver operating in the presence of white and colored noise is evaluated under dual channel and single channel operation. Under single channel operation, it is assumed that the colored noise jamming concentrates its energy around one of the FSK operating frequencies, and that the receiver is able to make a deterministic as to which "channel is being jammed" so that the outputs of this channel are ignored in the process of making decisions. Evaluations are carried out using receiver thresholds that are dependent as well as independent of jamming power levels.

(Both cases are considered separately.) The performance of the quadrature receiver in the presence of noise and the jamming

# QUADRATURE RECEIVER JSR=0

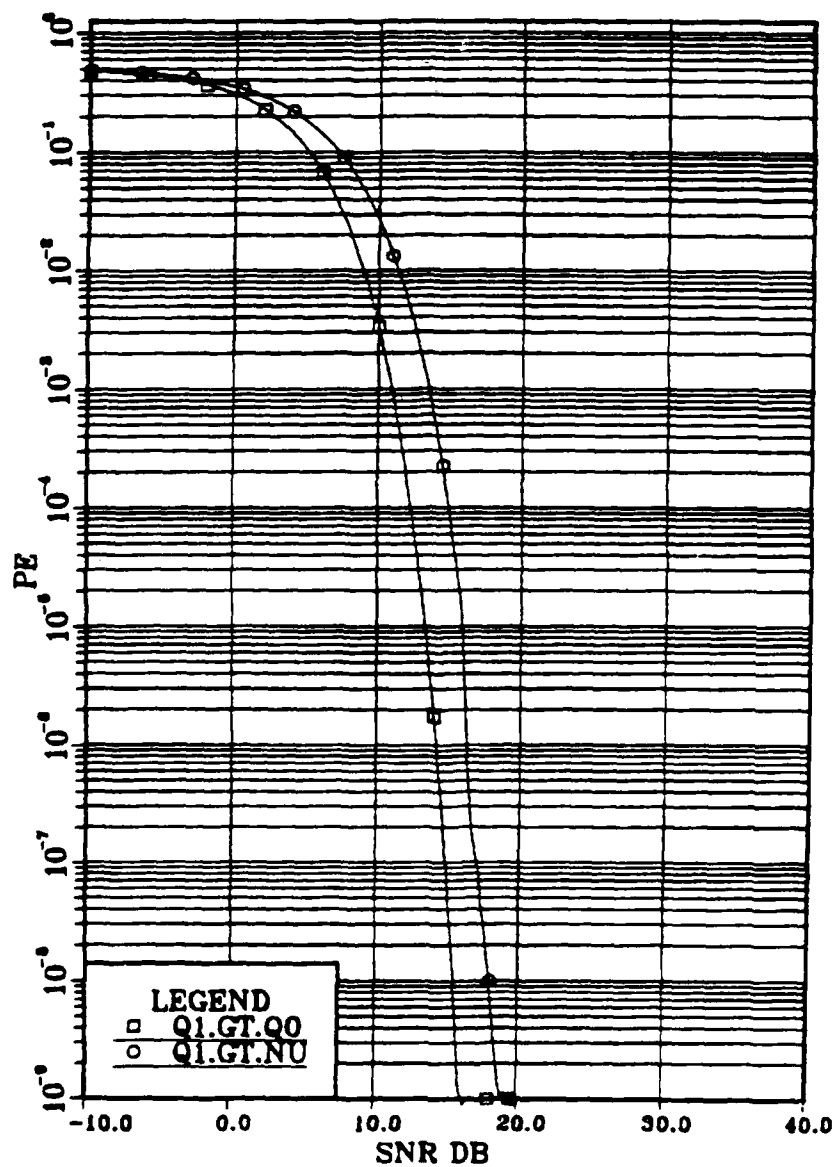

Figure 5.5. Performance of the quadrature receiver for JSR = 0

waveform described in this section in terms of the probability of error is calculated as the SNR changes for specified values of JSR. Some important results are summarized in Table 5.5 for JSR = 0 and in Tables 5.6-5.10 as JSR takes on values of 0.0 db, 5.0 db, 10.0 db, 15.0 and 20.0 db, respectively. In Figure 5.5 the performance of the standard quadrature receiver and the single channel operation of the quadrature receiver is plotted when the transmitted signal is interfered by white noise only. The theoretical performance of the standard quadrature receiver is calculated from Equation 4.10, and the performance of the quadrature receiver under single channel operation is calculated from Equation 4.87.

In Figures 5.6-5.10, the performance of the standard quadrature receiver and the quadrature receiver under single channel operation with the threshold dependent as well as independent of the jamming power level is plotted when the transmitted signal is interfered by white noise and by the jamming waveform having Power Spectral Density given by Equation C.7. Each of the figures corresponds to a specific value of JSR as shown in the headings. The performance of the standard quadrature receiver is calculated from Equation 4.73. The theoretical results for the single channel operation of the quadrature receiver with a threshold that is independent of the jamming power (Eq. 4.86) is calculated from Equation 4.82, and Equation 4.92 is used to compute performance of the same receiver when the threshold is dependent on the jamming power



TABLE 5.5

PERFORMANCE OF THE QUADRATURE RECEIVER JSR = 0

THE RECEIVER	$P_e$ SNR (DB)					
	-10.0	-5.0	0.0	5.0	10.0	15.0
Standard Operation	0.4756	0.4268	0.3032	0.1028	0.0033	0.00000006
Single Channel Operation	0.4820	0.4460	0.3531	0.1806	0.0268	0.00009

TABLE 5.6

PERFORMANCE OF THE QUADRATURE RECEIVER JSR = 0 DB

THE RECEIVER	$P_e$ SNR (DB)					
	-10.0	-5.0	0.0	5.0	10.0	15.0
Standard Operation	0.4767	0.4361	0.3582	0.2709	0.2172	0.1952
Single Channel Operation	0.4820	0.4460	0.3531	0.1806	0.0268	0.00009

TABLE 5.7

PERFORMANCE OF THE QUADRATURE RECEIVER JSR = 5 DB

THE RECEIVER	$P_e$ SNR (DB)					
	-10.0	-5.0	0.0	5.0	10.0	15.0
Standard Operation	0.4788	0.4499	0.4119	0.3841	0.3713	0.3667
Single Channel Operation	0.4820	0.4460	0.3531	0.1806	0.0268	0.00009

TABLE 5.8

PERFORMANCE OF THE QUADRATURE RECEIVER JSR = 10 DB

THE RECEIVER	$P_e$ SNR (DB)					
	-10.0	-5.0	0.0	5.0	10.0	15.0
Standard Operation	0.4836	0.4702	0.4600	0.4551	0.4533	0.4527
Single Channel Operation	0.4820	0.4460	0.3531	0.1806	0.0268	0.00009

TABLE 5.9

PERFORMANCE OF THE QUADRATURE RECEIVER JSR = 15 DB

THE RECEIVER	$P_e$ SNR (DB)					
	-10.0	-5.0	0.0	5.0	10.0	15.0
Standard Operation	0.4904	0.4869	0.4853	0.4847	0.4845	0.4844
Single Channel Operation	0.4820	0.4460	0.3531	0.1806	0.0268	0.00009

TABLE 5.10

PERFORMANCE OF THE QUADRATURE RECEIVER JSR = 20 DB

THE RECEIVER	$P_e$ SNR (DB)					
	-10.0	-5.0	0.0	5.0	10.0	15.0
Standard Operation	0.4958	0.4953	0.4951	0.4950	0.4950	0.4950
Single Channel Operation	0.4820	0.4460	0.3531	0.1806	0.0268	0.00009

### QUADRATURE RECEIVER JSR=0 DB

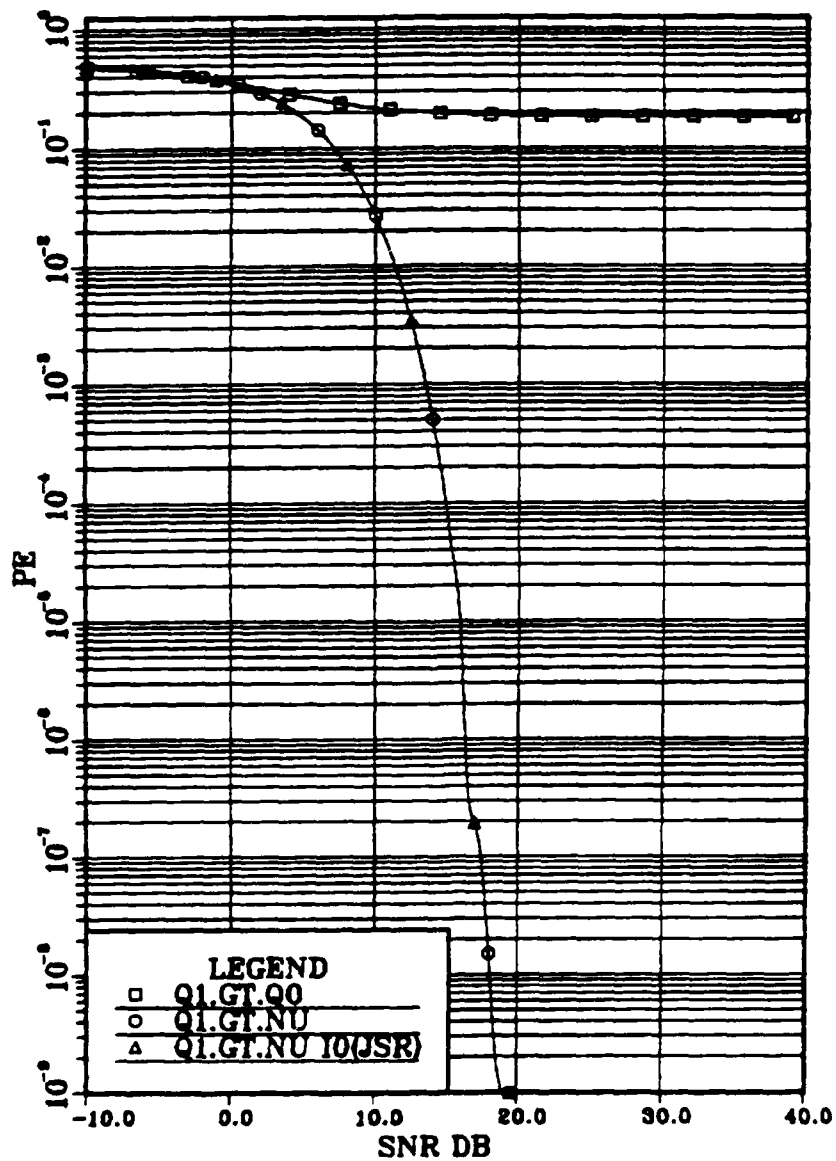

Figure 5.6. Performance of the quadrature receiver for JSR = 0 db

# QUADRATURE RECEIVER JSR=5 DB

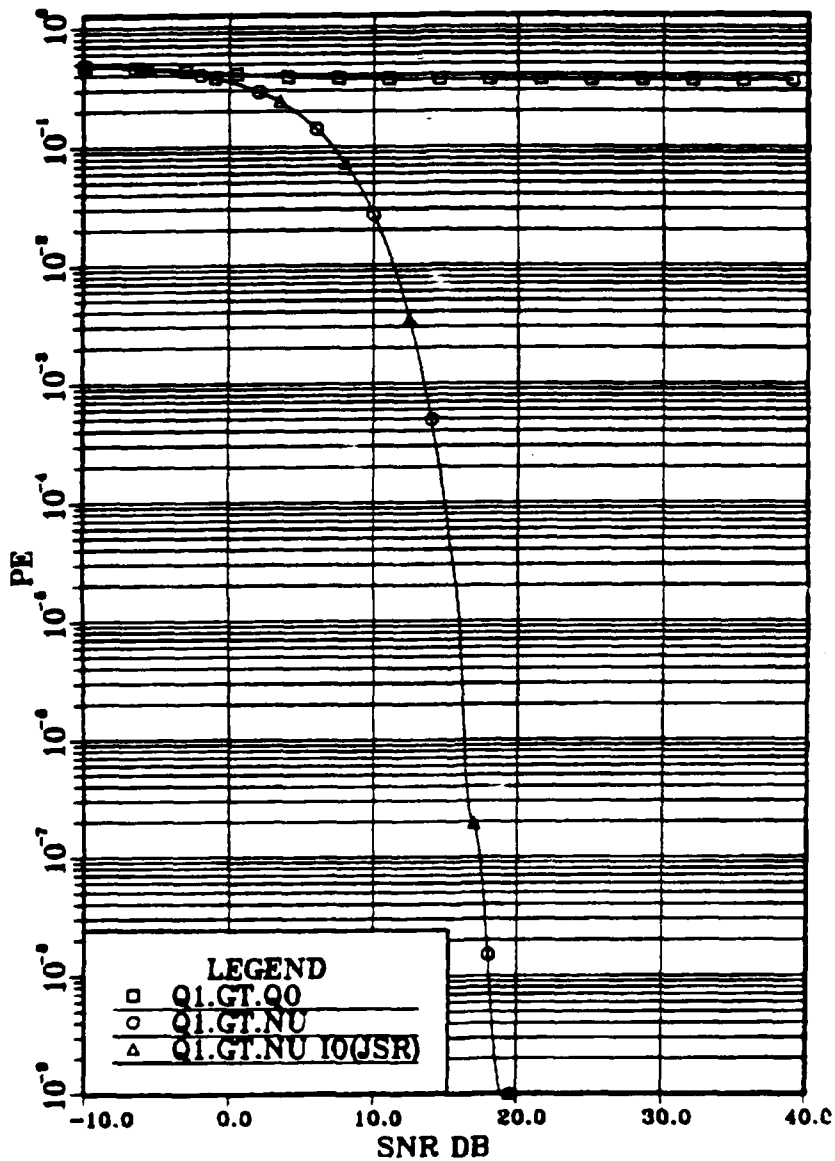

Figure 5.7. Performance of the quadrature receiver for JSR = 5 db

### QUADRATURE RECEIVER JSR=10 DB

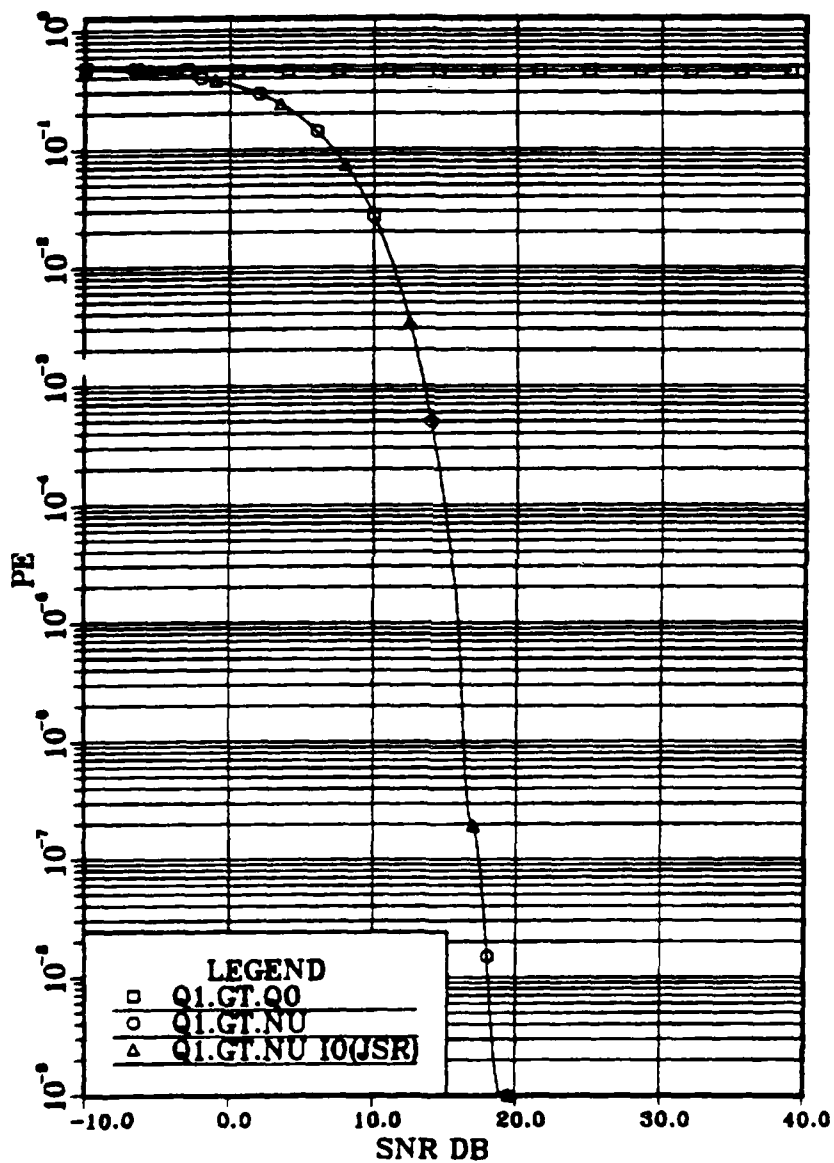

Figure 5.8. Performance of the quadrature receiver for JSR = 10 db

# QUADRATURE RECEIVER JSR=15 DB

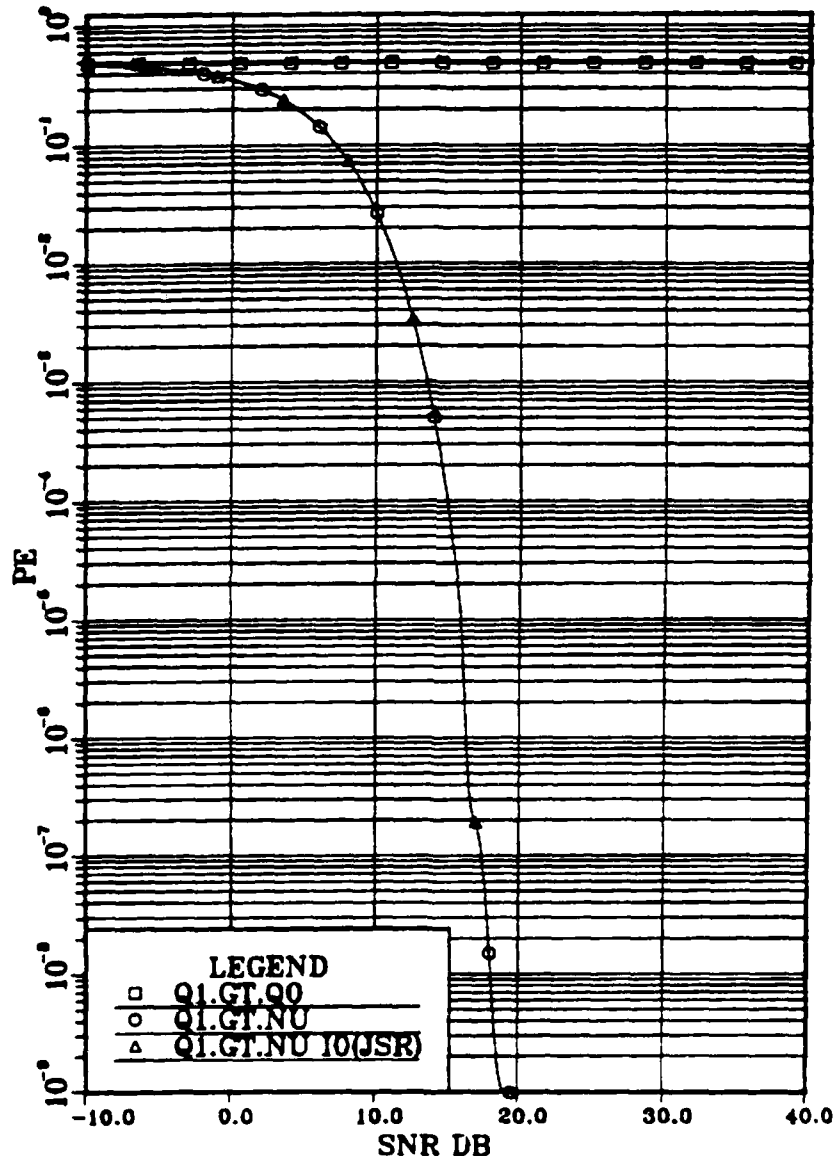

Figure 5.9. Performance of the quadrature receiver for JSR = 15 dB

# QUADRATURE RECEIVER JSR=20 DB

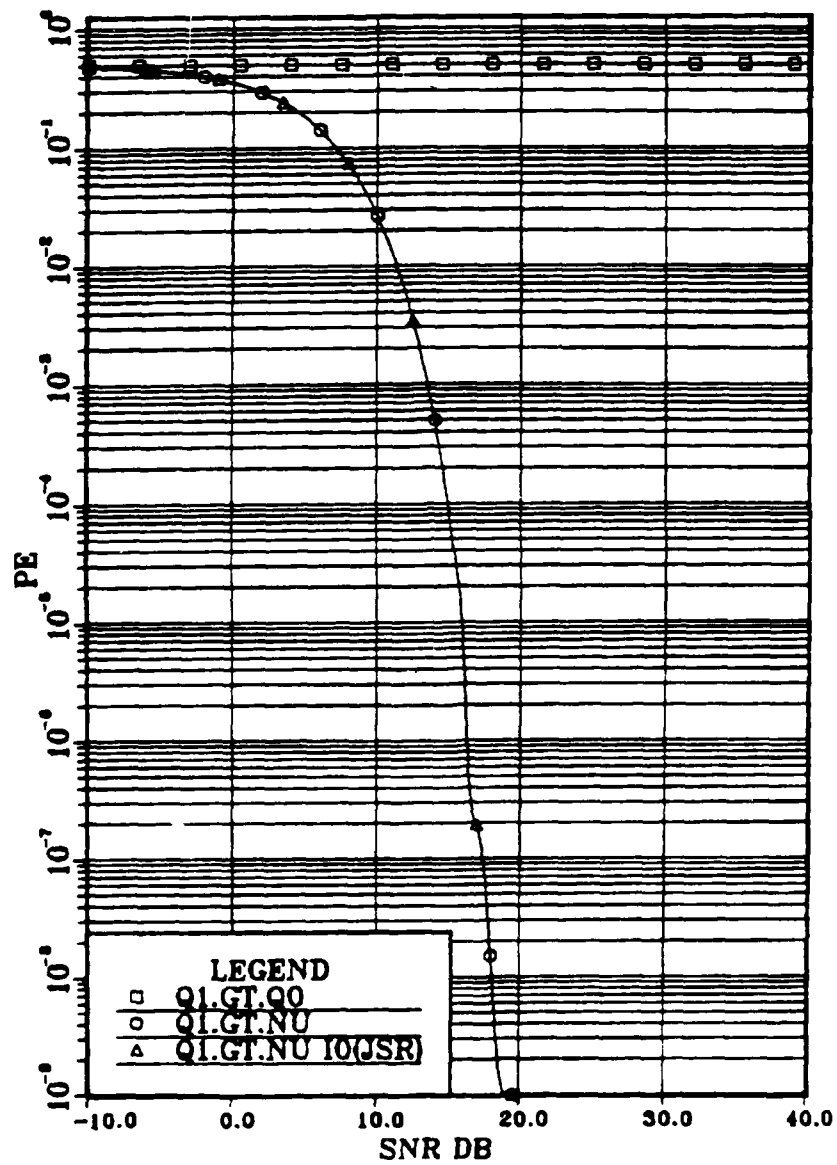

Figure 3.10. Performance of the quadrature receiver for JSR = 20 db



level. As pointed out in Section D of Chapter IV, the probability of error calculated from Equation 4.92 with the threshold set by Equations 4.86 and 4.93 show almost identical results.

Tables 5.5 through 5.10 demonstrate that the performance of the quadrature receiver under single channel operation is unaffected by changing values of JSR. This is due to the fact that for  $\omega_0$ ,  $\omega_1$  and T values used in the simulation, the value of SSQ term in Eq. 4.92 is identical to zero. Thus in order to demonstrate the effect of the jammer on the receiver under single channel operation, the value of the jamming frequency  $\omega_j$  has been allowed to vary from  $\omega_0$  all the way up to  $\omega_1$ . Thus, in place of the SSQ term as defined in Eq. 4.92, we use the modified term

$$SSQ = \frac{\sin(\omega_j - \omega_1)T/2}{(\omega_j - \omega_1)T/2} \quad \omega_0 \leq \omega_j \leq \omega_1$$

The results of these modifications are presented in Fig. 5.11 and Fig. 5.12 where the probability of error of the receiver given by Eq. 4.93 is evaluated for JSR = 5 db and JSR = 10 db, respectively, where the jamming frequency ( $\omega_j$ ) is allowed to take on values  $\omega_j = \omega_0$  (which corresponds to the results given by Eqs. 4.91 and 4.92 without modification), and values of  $\omega_j = 3(\omega_1 + \omega_0)/4$  and  $\omega_j = \omega_1$ . Some of the important results obtained are summarized in Tables 5.11 and 5.12 for JSR = 5 db and JSR = 10 db respectively.

# B F S K (JSR=5 DB)

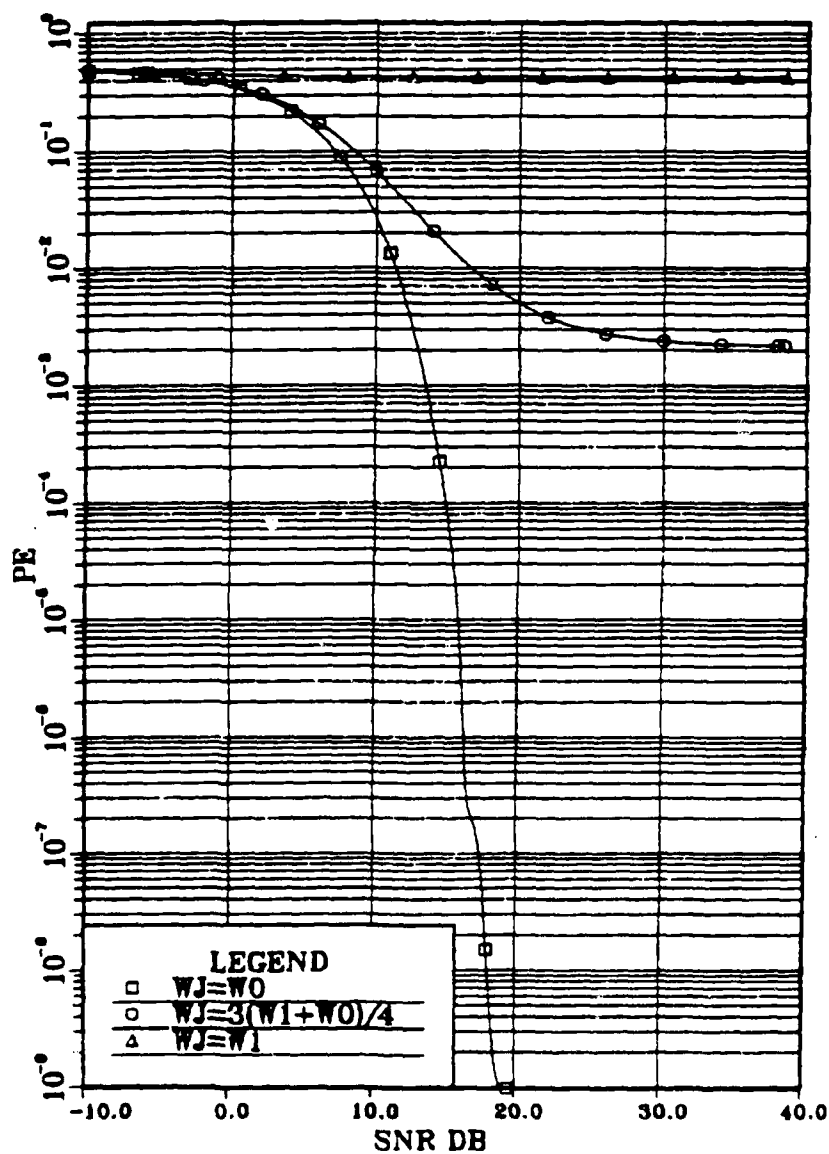

Figure 5.11. Performance of the quadrature receiver single mode operation for different jamming frequencies and JSR = 5 db

AD-A164 522

JAMMING EFFECTS ON M-ARY COHERENT AND BINARY  
NONCOHERENT DIGITAL RECEIVERS USING RANDOM JAMMER  
MODELS(U) NAVAL POSTGRADUATE SCHOOL MONTEREY CA  
L A MUNOZ DEC 85

2/2

UNCLASSIFIED

F/G 17/4

NL



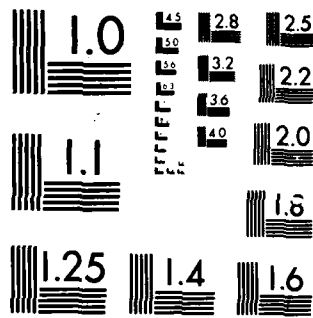

MICROCOPY RESOLUTION TEST CHART  
NATIONAL BUREAU OF STANDARDS 1963-A

# B F S K (JSR=10 DB)

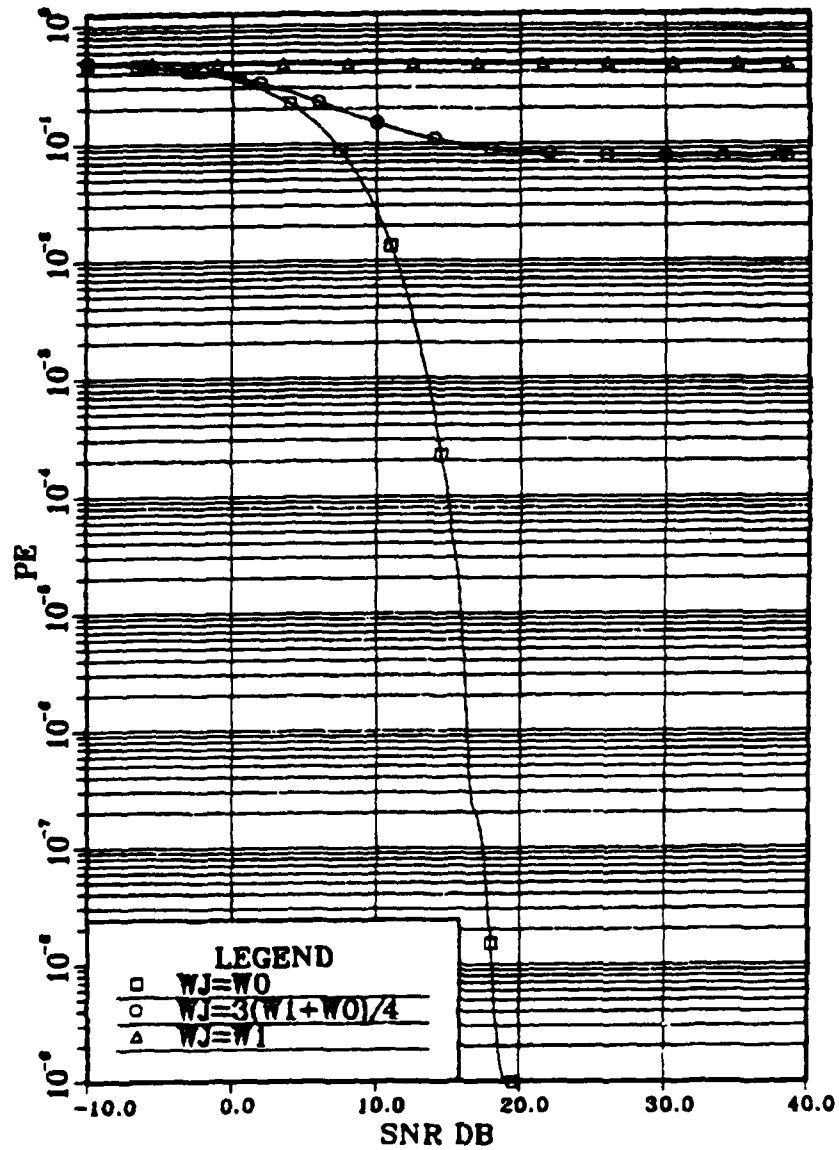

Figure 5.12. Performance of the quadrature receiver single channel operation for different jamming frequencies and JSR = 10 db

TABLE 5.11

PERFORMANCE OF THE QUADRATURE RECEIVER SINGLE CHANNEL OPERATION  
FOR DIFFERENT JAMMING FREQUENCIES AND JSR = 5 DB

THE RECEIVER	SNR DB				
	-10.0	0.0	10.0	20.0	30.0
$\omega_j = \omega_0$	0.4820	0.3530	0.0268	$1 \times 10^{-9}$	$1 \times 10^{-9}$
$\omega_j = \frac{3}{4}(\omega_1 + \omega_0)$	0.4821	0.3589	0.0676	0.0049	0.0023
$\omega_j = \omega_1$	0.4853	0.4476	0.4297	0.4272	0.4269

TABLE 5.12

PERFORMANCE OF THE QUADRATURE RECEIVER SINGLE CHANNEL OPERATION  
FOR DIFFERENT JAMMING FREQUENCIES AND JSR = 10 DB

THE RECEIVER	SNR DB				
	-10.0	0.0	10.0	20.0	30.0
$\omega_j = \omega_0$	0.4820	0.3531	0.0268	$1 \times 10^{-9}$	$1 \times 10^{-9}$
$\omega_j = \frac{3}{4}(\omega_1 + \omega_0)$	0.4823	0.3699	0.1491	0.0849	0.0773
$\omega_j = \omega_1$	0.4894	0.4781	0.4755	0.4752	0.4751

## VI. CONCLUSIONS

The analysis carried out in this thesis presents the application of concepts derived in statistical communication theory, specifically in the theory of signal detection under the assumption of colored noise interference. The performance of digital receivers in terms of probability of error is determined when the receivers operate in the presence of white and colored Gaussian noise. Three techniques are examined separately, one for MPSK modulation, another for coherent MFSK modulation and the last one for (incoherent) BFSK modulation.

The mathematical model of the jamming waveform proposed, consists of colored Gaussian noise of different spectral shapes and power content.

For MPSK modulation, a mathematical result on the performance of the (coherent) receiver in the presence of WGN and colored noise jamming was derived. The complexity of the result along with the many possible trade-offs involving spectral shapes, power levels and frequencies of operation made it impossible to address in this thesis the issue of optimum jamming strategies for MPSK.

For MFSK modulation results on the effect of the coherent receiver, were derived. A simple assumption was made on the spectrum of the jamming. By assuming that each signal frequency

was interfered with a tone subject to a total jamming power constraint, the receiver  $P_e$  was evaluated for different values of SNR, JSR, and M. The results demonstrate that this form of jamming can be quite effective or that significant increases on  $P_e$  can be achieved even at low JSR values.

For the case of BFSK modulation, the quadrature receiver was analyzed under two conditions of operation, standard operation and single channel operation, in the presence of colored noise jamming with different power levels. The single channel operation was introduced as a method for mitigating the effect of a single tone jammer at one of the carrier frequencies. When no jamming is present, single channel operation performs slightly worse than standard receiver (both channels) operation. However, in the presence of jamming, single channel operation is superior to standard operation because the receiver is capable of eliminating much of the jammer energy and its effect by ignoring the output of the jammed channel during single channel operation. As pointed out in Chapter IV, the effect of the jamming waveform on the receiver under single channel operation depends strongly on the jamming frequency chosen. For the single channel operation, it was assumed that the jamming is present at one of the two signal frequencies, and that the receiver turns off the channel affected. Thus, decisions are made based only on the output of the unaffected channel. However, if under this condition of operation the jamming changes its frequency  $\omega_j$  in such a way as to "move



closer" to the frequency of the unaffected channel, it has been demonstrated that the receiver probability of error increases as  $\omega_j$  approaches the frequency of the unaffected channel.

APPENDIX A

DETAILED INVESTIGATION OF THE VARIANCES OF  $V_C$  AND  $V_S$   
CONDITIONED ON HYPOTHESES  $H_j$

Let

$$\psi_{\ell}^T = \begin{cases} \psi_{\ell}(t) & 0 \leq t \leq T \quad \ell = 1, 2 \\ 0 & \text{otherwise} \end{cases} \quad (\text{A.1})$$

and

$$\psi_{\ell}^T(\omega) = F\{\psi_{\ell}^T(t)\} \quad \ell = 1, 2 \quad (\text{A.2})$$

Thus

$$\begin{aligned} \sigma_{C, \ell}^2 &= \iiint_{-\infty}^{\infty} K_C(t-\tau) \psi_{\ell}^T(t) \psi_{\ell}^T(\tau) dt d\tau \\ &= \int_{-\infty}^{\infty} \int_{-\infty}^{\infty} \frac{1}{2\pi} S_C(\omega) e^{j\omega(t-\tau)} d\omega \psi_{\ell}^T(t) \psi_{\ell}^T(\tau) dt d\tau \\ &= \frac{1}{2\pi} \int_{-\infty}^{\infty} S_C(\tau) \psi_{\ell}^T(-\omega) \psi_{\ell}^T(\omega) d\omega \end{aligned} \quad (\text{A.3})$$

where  $K_C(\tau) \rightarrow S_C(\omega)$

Now

$$\begin{aligned} \psi_1^T(\omega) = & \frac{1}{2} \left[ \sqrt{2T} e^{-j(\omega - 2\pi n/T)T/2} \frac{\text{Sin}(\omega - \frac{2\pi n}{T})T/2}{(\omega - \frac{2\pi n}{T})T/2} \right. \\ & \left. + \sqrt{2T} e^{-j(\omega + 2\pi n/T)T/2} \frac{\text{Sin}(\omega + \frac{2\pi n}{T})T/2}{(\omega + \frac{2\pi n}{T})T/2} \right] \end{aligned} \quad (\text{A.4})$$

and

$$\psi_2^T(\omega) = e^{-j\omega T/4n} \psi_1^T(\omega) \quad (\text{A.5})$$

Because of the relationship between  $\psi_1^T(\omega)$  and  $\psi_2^T(\omega)$ , it is clear that

$$\psi_1^T(-\omega) \psi_1^T(\omega) = \psi_2^T(-\omega) \psi_2^T(\omega) \quad (\text{A.6})$$

so that

$$\sigma_{c,1}^2 = \sigma_{c,2}^2 \triangleq \sigma_c^2 \quad (\text{A.7})$$

Thus indeed,  $a = c$ . Observe also by similar arguments, that

$$\begin{aligned} \sigma_{1,2}^2 &= \frac{1}{2\pi} \int_{-\infty}^{\infty} S_c(\omega) \psi_1^T(-\omega) \psi_2^T(\omega) d\omega = \frac{1}{2\pi} \int_{-\infty}^{\infty} S_c(\omega) \psi_1^T(-\omega) e^{j\omega T/4n} \psi_1^T(\omega) d\omega \\ &= \frac{1}{2\pi} \int_{-\infty}^{\infty} S_c(\omega) |\psi_1^T(\omega)|^2 \cos \frac{\omega T}{4n} d\omega \end{aligned} \quad (\text{A.8})$$

where

$$|\psi_1^T(\omega)|^2 = \frac{T}{2} \left\{ \left[ \frac{\sin(\frac{\omega T}{2} - n\pi)}{(\frac{\omega T}{2} - n\pi)} \right]^2 + \left[ \frac{\sin(\frac{\omega T}{2} + n\pi)}{(\frac{\omega T}{2} + n\pi)} \right]^2 \right. \\ \left. + \frac{\sin(\frac{\omega T}{2} - n\pi)}{(\frac{\omega T}{2} - n\pi)} \cdot \frac{\sin(\frac{\omega T}{2} + n\pi)}{(\frac{\omega T}{2} + n\pi)} \right\} \quad (\text{A.9})$$

So it is clear that in general,  $\sigma_{1,2}^2$  will not be zero.

APPENDIX B

DETAILED INVESTIGATION OF THE BEHAVIOR OF THE PRODUCTS OF

$S_j'(-\omega)$  AND  $S_k'(\omega)$

We have defined

$$F\{S_j'(t)p(t)\} = \frac{AT}{2}[L(\omega - \omega_c - \omega_j) + L(\omega + \omega_c + \omega_j)] \quad (B.1)$$

Then

$$\begin{aligned} F\{S_j'(t)p(t)\} \times F\{S_k'(\tau)p(\tau)\} &= S_j'(-\omega)S_k'(\omega) \\ &= \frac{AT}{2}[L(-\omega - \omega_c - \omega_j) + L(-\omega + \omega_c + \omega_j)] \frac{AT}{2}[L(\omega - \omega_c - \omega_k) + L(\omega + \omega_c + \omega_k)] \\ &= \left(\frac{AT}{2}\right)^2 [L(\omega - \omega_c - \omega_j)L(\omega - \omega_c - \omega_k) + L(-\omega + \omega_c + \omega_j)L(\omega - \omega_c - \omega_k) \\ &\quad + L(-\omega - \omega_c - \omega_j)L(\omega + \omega_c + \omega_j) + L(-\omega + \omega_c + \omega_j)L(\omega + \omega_c + \omega_k)] \end{aligned} \quad (B.2)$$

Observe that for reasonably large values of  $\omega_c$ , the first and the last term in this expression vanish, and we are left with the products

$$\begin{aligned}
& e^{j(\omega_k - \omega_j)T/2} \frac{\sin(\omega - \omega_c - \omega_j)T/2}{(\omega - \omega_c - \omega_j)T/2} \cdot \frac{\sin(\omega - \omega_c - \omega_k)T/2}{(\omega - \omega_c - \omega_k)T/2} \\
& + e^{-j(\omega_k - \omega_j)T/2} \frac{\sin(\omega + \omega_c + \omega_j)T/2}{(\omega + \omega_c + \omega_j)T/2} \cdot \frac{\sin(\omega + \omega_c + \omega_k)T/2}{(\omega + \omega_c + \omega_k)T/2}
\end{aligned} \tag{B.3}$$

Now focusing on the first term of Eq. B.3, which has significant components for  $\omega$  in the neighborhood of  $\omega_c$ , we see that if  $j-k \gg 1$  then there is essentially no overlap between sine functions. Therefore the product  $S_j^*(-\omega)S_k(\omega)$  is zero for  $j \neq k$ .

For  $k = j \pm 1$ , we have

$$\begin{aligned}
& \sin(\omega - \omega_c - \omega_j)T/2 \sin(\omega - \omega_c - \omega_k)T/2 \\
& = \frac{1}{2} \cos(\omega_k - \omega_j)T/2 - \frac{1}{2} \cos(2\omega - 2\omega_c - \omega_j - \omega_k)T/2
\end{aligned} \tag{B.4}$$

and when  $\omega$  is in the neighborhood of  $\omega_c$ , the product becomes approximately

$$\begin{aligned}
& \frac{e^{j(\omega_k - \omega_j)T/2}}{2} \left[ \frac{\cos(\omega_k - \omega_j)T/2 - \cos(\omega_j + \omega_k)T/2}{\omega_j T/2 \cdot \omega_k T/2} \right] \\
& = e^{j(k-j)\Delta\omega T/2} \left[ \frac{\cos(k-j)\Delta\omega T/2 - \cos(k-j)\Delta\omega T/2}{\left(k - \frac{M+1}{2}\right)T/2 \left(j - \frac{M+1}{2}\right)T/2} \right]
\end{aligned} \tag{B.5}$$

The orthogonality condition on the signals required that  $\Delta\omega T = \pi$  or  $\Delta\omega T/2 = \pi/2$ , so that Eq. B.5 becomes (approximately)

$$\frac{e^{\pm j\pi/2}}{(\pi/2)^2} \left[ \frac{\cos(\pm\pi/2) - \cos(2j \pm 1)\pi/2}{\left(j - \frac{M+1}{2}\right)^2 \pm \left(j - \frac{M+1}{2}\right)} \right] =$$

$$= \frac{\pm j}{(\pi/2)^2} \left[ \frac{\cos j\pi \cos \pi/2 \pm \sin j\pi \sin \pi/2}{\left(j - \frac{M+1}{2}\right)^2 \pm \left(j - \frac{M+1}{2}\right)} \right] \quad (\text{B.6})$$

Eq. B.6 is zero for all values of the integer  $j$ , so we have that for  $\Delta\omega T = \pi$ , the product  $S_j^*(-\omega)S_k(\omega)$  is equal to zero for  $j \neq k$ .

APPENDIX C

DETAILED INVESTIGATION OF THE VARIANCES  
 $\sigma_{C,0}^2$  AND  $\sigma_{C,1}^2$  DUE TO COLORED NOISE

Let us define

$$P_{C_i}(t) = \cos \omega_i t \quad i = 0,1 \quad 0 \leq t \leq T \quad (C.1)$$

Then Eq. 4.69 becomes

$$\begin{aligned} \sigma_{C,0}^2 + \sigma_{C,1}^2 &= \iiint_{-\infty}^{\infty} K_C(t-\tau) P_{C_0}(t) P_{C_0}(\tau) dt d\tau \\ &\quad + \iiint_{-\infty}^{\infty} K_C(t-\tau) P_{C_1}(t) P_{C_1}(\tau) dt d\tau \\ &= \frac{1}{2\pi} \int_{-\infty}^{\infty} S_C(\omega) \iiint_{-\infty}^{\infty} e^{j\omega(t-\tau)} P_{C_0}(t) P_{C_0}(\tau) dt d\tau d\omega \\ &\quad + \frac{1}{2\pi} \int_{-\infty}^{\infty} S_C(\omega) \iiint_{-\infty}^{\infty} e^{j\omega(t-\tau)} P_{C_1}(t) P_{C_1}(\tau) dt d\tau d\omega \\ &= \frac{1}{2\pi} \int_{-\infty}^{\infty} S_C(\omega) \{ |P_{C_0}(\omega)|^2 + |P_{C_1}(\omega)|^2 \} d\omega \end{aligned} \quad (C.2)$$

where



$$P_{ci}(\omega) = \int_0^T \cos \omega_i t e^{-j\omega t} dt = \frac{T}{2} e^{j(\omega_i - \omega)T/2} \frac{\sin(\omega_i - \omega)T/2}{(\omega_i - \omega)T/2} + \frac{T}{2} e^{-j(\omega_i + \omega)T/2} \frac{\sin(\omega_i + \omega)T/2}{(\omega_i + \omega)T/2} \quad i = 0, 1 \quad (C.3)$$

and

$$S_c(\omega) \leftrightarrow K_c(\tau)$$

Furthermore

$$|P_{ci}(\omega)|^2 = \left(\frac{T}{2}\right)^2 \left(\frac{\sin(\omega_i - \omega)T/2}{(\omega_i - \omega)T/2}\right)^2 + \left(\frac{T}{2}\right)^2 \left(\frac{\sin(\omega_i + \omega)T/2}{(\omega_i + \omega)T/2}\right)^2 + \left(\frac{T}{2}\right)^2 2 \cos \omega_i T \frac{\sin(\omega_i - \omega)T/2}{(\omega_i - \omega)T/2} \cdot \frac{\sin(\omega_i + \omega)T/2}{(\omega_i + \omega)T/2} \quad i = 0, 1 \quad (C.4)$$

The third term in Eq. C.4 can be assumed for all practical purposes to be zero. In essence, we require that  $\omega_i \gg 2\pi/T$ ,  $i = 0, 1$  for the approximation to be correct.

Consider now the case where

$$S_c(\omega) = K[\delta(\omega - \omega_j) + \delta(\omega + \omega_j)] \quad (C.5)$$

Since

$$\begin{aligned}
P_c &= \frac{1}{2\pi} \int_{-\infty}^{\infty} S_c(\omega) d\omega \\
&= \frac{K}{2\pi} \int_{-\infty}^{\infty} [\delta(\omega - \omega_j) + \delta(\omega + \omega_j)] d\omega = \frac{K}{\pi}
\end{aligned} \tag{C.6}$$

then  $K = \pi P_c$  so that we use

$$S_c(\omega) = \pi P_c [\delta(\omega - \omega_j) + \delta(\omega + \omega_j)] \tag{C.7}$$

From Eq. C.2, we now have

$$\begin{aligned}
\sigma_{c,0}^2 + \sigma_{c,1}^2 &= \frac{P_c}{2} [ |P_{co}(\omega_j)|^2 + |P_{co}(-\omega_j)|^2 \\
&\quad + |P_{cl}(\omega_j)|^2 + |P_{cl}(-\omega_j)|^2 ]
\end{aligned} \tag{C.8}$$

Assuming that  $\omega_j$  will always be in the vicinity of  $\omega_0$  and  $\omega_1$  we can state that

$$|P_{co}(\omega_j)|^2 \cong \left(\frac{T}{2}\right)^2 \left(\frac{\text{Sin}(\omega_0 - \omega_j)T/2}{(\omega_0 - \omega_j)T/2}\right)^2 \tag{C.9}$$

$$|P_{co}(-\omega_j)|^2 \cong \left(\frac{T}{2}\right)^2 \left(\frac{\text{Sin}(\omega_0 - \omega_j)T/2}{(\omega_0 - \omega_j)T/2}\right)^2 \tag{C.10}$$

$$|P_{cl}(\omega_j)|^2 \cong \left(\frac{T}{2}\right)^2 \left(\frac{\text{Sin}(\omega_1 - \omega_j)T/2}{(\omega_1 - \omega_j)T/2}\right)^2 = |P_{cl}(-\omega_j)|^2 \tag{C.11}$$

Thus

$$\begin{aligned}
 \sigma_{c,0}^2 + \sigma_{c,1}^2 &= \frac{P_c}{2} \left[ 2 \left( \frac{T}{2} \right)^2 \left( \frac{\sin(\omega_0 - \omega_j)T/2}{(\omega_0 - \omega_j)T/2} \right)^2 + 2 \left( \frac{T}{2} \right)^2 \left( \frac{\sin(\omega_1 - \omega_j)T/2}{(\omega_1 - \omega_j)T/2} \right)^2 \right] \\
 &= \frac{P_c T^2}{4} \left[ \left( \frac{\sin(\omega_0 - \omega_j)T/2}{(\omega_0 - \omega_j)T/2} \right)^2 + \left( \frac{\sin(\omega_1 - \omega_j)T/2}{(\omega_1 - \omega_j)T/2} \right)^2 \right] \quad (C.12)
 \end{aligned}$$

In order to maximize the quantity in brackets as a function of  $\omega_j$ , we need to take derivatives of the expression and set it equal to zero. The result of this operation leads to a maximum at values of  $\omega_j = \omega_0$  or  $\omega_j = \omega_1$ . Therefore, the maximum value becomes

$$\left( \sigma_{c,0}^2 + \sigma_{c,1}^2 \right)_{\max} = \frac{P_c T^2}{4} \left[ \left( \frac{\sin(\omega_1 - \omega_0)T/2}{(\omega_1 - \omega_0)T/2} \right)^2 + 1 \right] \quad (C.13)$$

### LIST OF REFERENCES

1. Van Trees, Harry L., Detection Estimation and Modulation Theory, Part I, pp. 246-287, Wiley, 1968.
2. Srinath, M., P.K. Rajasekaran, An Introduction to Statistical Signal Processing with Applications, pp. 104-120, John Wiley, 1979.
3. Wozencraft, J., I.M. Jacobs, Principles of Communication Engineering, pp. 211-273, John Wiley, 1965.
4. Hasarchi, A., An Analysis of Coherent Digital Receivers in the Presence of Colored Noise Interference, Master's Thesis, Naval Postgraduate School, Monterey, California, June 1985.
5. Van Trees, Harry L., Detection, Estimation and Modulation Theory, Part I, pp. 96-98, Wiley, 1968.
6. Papoulis, A., Probability, Random Variables and Stochastic Processes, pp. 143-146, Second Edition, McGraw-Hill, 1984.
7. Van Trees, Harry L., Detection, Estimation and Modulation Theory, Part I, pp. 247-257, Wiley, 1968.
8. Whalen, Anthony D., Detection of Signals in Noise, pp. 209-210, Academic Press, 1971.
9. Whalen, Anthony D., Detection of Signals in Noise, pp. 210-211, Academic Press, 1971.
10. Whalen, Anthony D., Detection of Signals in Noise, pp. 105-106, Academic Press, 1971.
11. Van Trees, Harry L., Detection, Estimation and Modulation Theory, Part I, pp. 395, Wiley, 1968.

INITIAL DISTRIBUTION LIST

	No. Copies
1. Defense Technical Information Center Cameron Station Alexandria, Virginia 22304-6145	2
2. Library, Code 0142 Naval Postgraduate School Monterey, California 93943-5100	2
3. Prof. Harriett B. Rigas, Code 62 Naval Postgraduate School Monterey, California 93943-5100	1
4. Prof. D. Bukofzer, Code 62Bh Naval Postgraduate School Monterey, California 93943-5100	5
5. Prof. S. Jaurequi, Code 62Ja Naval Postgraduate School Monterey, California 93943-5100	2
6. Peruvian Military Attache 2201 Wisconsin Ave. N.W. Suite 360 Washington, DC 20007	1
7. Peruvian Military Attache Dirección de Instrucción e Instituto Tecnológico del Ejército 2201 Wisconsin Ave. N.W. Suite 360 Washington, DC 20007	2
8. Maj. Juis A. Muñoz Calle Union No. 164 Monterrico Chico Lima 33 PERU	2

**END**

**FILMED**

**386**

**DTIC**