

MICROCOPY RESOLUTION TEST CHART
NATIONAL BUREAU OF STANDARDS-1963-A



12

DEPARTMENT OF DEFENCE
DEFENCE SCIENCE AND TECHNOLOGY ORGANISATION
MATERIALS RESEARCH LABORATORIES
MELBOURNE, VICTORIA

AD-A164 429

REPORT
MRL-R-973

DTIC
ELECTE
FEB 21 1988
S D

APPLICATION OF THE PUGH, EICHELBERG AND ROSTOKER
THEORY TO THE MRL 38 MM SHAPED CHARGE

D.A. Jones

THE UNITED STATES NATIONAL
TECHNICAL INFORMATION SERVICE
IS AUTHORIZED TO
REPRODUCE AND SELL THIS REPORT

DTIC FILE COPY

Approved for Public Release



86 2 21 007

Commonwealth of Australia
SEPTEMBER, 1985

DEPARTMENT OF DEFENCE
MATERIALS RESEARCH LABORATORIES

REPORT

MRL-R-973

APPLICATION OF THE PUGH, EICHELBERG AND ROSTOKER
THEORY TO THE MRL 38 MM SHAPED CHARGE

D.A. Jones

ABSTRACT

Y. ...
(Materials Research Labs)
A simple model of the MRL 38 mm shaped charge ~~is described~~ which is based on the analytical work of Pugh, Eichelberg and Rostoker. The modified Richter equation is used to estimate the bending angle δ and then the steady state Taylor equation is used to calculate the initial liner speed V_0 . The inverse velocity gradient effect is included by allowing the liner to have a velocity-time curve of the type described by Carleone, Jameson and Chou. The three phenomenological constants required for this type of approach are found by fitting the model to data from the BRL 105 mm unconfined shaped charge, and the model is then used to calculate the jet velocity gradient and the collapse angle versus time for the MRL shaped charge. Good agreement with recent experimental results is found. The report concludes by discussing the utility of the model for various parametric studies, and an illustration is given by calculating the dependence of jet tip velocity on cone half angle.

Shaped charge ... mathematical models

Approved for Public Release

POSTAL ADDRESS: Director, Materials Research Laboratories
P.O. Box 50, Ascot Vale, Victoria 3032, Australia

DOCUMENT CONTROL DATA SHEET

REPORT NO. MRL-R-973	AR NO. AR-004-338	REPORT SECURITY CLASSIFICATION Unclassified
-------------------------	----------------------	--

TITLE

Application of the Pugh Eichelberg and Rostoker
theory to the MRL 38 mm shaped charge

AUTHOR(S)

D.A. Jones

CORPORATE AUTHOR
Materials Research Laboratories
P.O. Box 50,
Ascot Vale, Victoria 3032

REPORT DATE
September, 1985

TASK NO.
DST 85/158

SPONSOR
DSTO

FILE NO.
G6/4/8-3066

REFERENCES
32

PAGES
27

CLASSIFICATION/LIMITATION REVIEW DATE

CLASSIFICATION/RELEASE AUTHORITY
Superintendent, MRL
Physical Chemistry Division

SECONDARY DISTRIBUTION

Approved for Public Release

ANNOUNCEMENT

Announcement of this report is unlimited

KEYWORDS

Shaped charges
Jets
Mathematical models

COSATI GROUPS 1901

ABSTRACT

A simple model of the MRL 38 mm shaped charge is described which is based on the analytical work of Pugh, Eichelberg and Rostoker. The modified Richter equation is used to estimate the bending angle δ and then the steady state Taylor equation is used to calculate the initial liner speed V_0 . The inverse velocity gradient effect is included by allowing the liner to have a velocity-time curve of the type described by Carleone, Jameson and Chou. The three phenomenological constants required for this type of approach are found by fitting the model to data from the BRL 105 mm unconfined shaped charge, and the model is then used to calculate the jet velocity gradient and the collapse angle versus time for the MRL shaped charge. Good agreement with recent experimental results is found. The report concludes by discussing the utility of the model for various parametric studies, and an illustration is given by calculating the dependence of jet tip velocity on cone half angle.

C O N T E N T S

	<u>Page No.</u>
1. INTRODUCTION	1
2. DESCRIPTION OF EQUATIONS	2
3. DETERMINATION OF PHENOMENOLOGICAL CONSTANTS	5
4. APPLICATION TO MRL 38 MM SHAPED CHARGE	6
5. CONCLUDING REMARKS	9
6. ACKNOWLEDGEMENTS	10
7. REFERENCES	11



Accession For	
NTIS CRA&I	<input checked="" type="checkbox"/>
DTIC TAB	<input type="checkbox"/>
Unannounced	<input type="checkbox"/>
Justification	
By	
Distribution/	
Availability Codes	
Dist	Avail a. d/or Special
A-1	

APPLICATION OF THE PUGH, EICHELBERG AND ROSTOKER

THEORY TO THE MRL 38 MM SHAPED CHARGE

1. INTRODUCTION

The use and understanding of shaped charge warheads has been, and continues to be, of considerable interest to MRL. The Australian Army currently employs two shaped charge weapons, the 66 mm M72 L1A2 (LAW) and 84 mm Carl Gustaf anti-tank weapons, and there is continuing interest in the 103 mm MILAN, a shaped charge warhead which incorporates wave shaping for increased performance. The selection, performance, and possible modification of such weapons to fit Australian requirements is obviously facilitated by a thorough understanding of the mechanisms of liner collapse and jet formation.

A 38 mm shaped charge with 42° angle copper liner and Comp. B explosive was designed and tested at MRL some years ago [1]. This particular shaped charge, now known as the MRL standard shaped charge, is currently being used by M.C. Chick and co-workers for a very illuminating investigation on the jet initiation and disruption of bare and covered Comp. B and other explosives [2a,2b].

The process of liner collapse and jet formation in the MRL Standard Shaped Charge has recently been modelled by D.L. Smith using the two-dimensional hydrodynamics finite-difference code HELP [3], and initial comparison between flash radiographs of liner collapse and the HELP output are most encouraging [4], although the code does have problems in accurately modelling the jet tip. While HELP appears to be capable of modelling the jet formation process for the MRL standard shaped charge with good overall precision, it is not ideally suited to parametric or design studies because of the extensive amount of computing time required, with each run costing several hundred dollars.

A different approach to the analysis of shaped charge performance is to use one of the many so called "one dimensional" codes (1D), all of which are based on the analytical work of Pugh, Eichelberg and Rostoker [5], (PER). A number of these codes have appeared in the last few years, the best

known of these probably being the BASIC code of J.T. Harrison of BRL [6], while others are the DESC-1 code of Carleone et al of Dyna East Corp. [7], the JETFORM code at RARDE [8], and the TB/ISL code of Hennequin in France [9]. Each of these codes is based on the evaluation of simple analytical expressions rather than the solution of a set of one dimensional finite difference equations, as the name would suggest, and hence the saving in computer time when compared with a 2D hydrocode run is enormous. Such codes are ideally suited to parametric studies and are an integral part of the overall design process, as recently outlined by Carleone et al [10].

Despite having acquired several large 2D hydrocodes in the past few years, the most notable of these being the previously mentioned HELP code, as well as 2DL [11], HULL [12], and HEMP [13], MRL has not yet obtained any of the 1D codes for shaped charge analysis. It was felt that an MRL 1D code should be developed first and applied to the standard MRL shaped charge before any of the overseas 1D codes were considered. The advantages of such an approach are an increased understanding of the basic physics involved in the liner collapse and jet formation process, and a greater appreciation of what to look for in other 1D codes if these become available at MRL. The purpose of this report then is to describe the progress made so far in the modelling of the MRL standard shaped charge using the "1D code" type of approach. In the next section a description is given of the basic equations. No attempt has been made to derive these as a detailed description of the derivation of the basic PER equations has recently been given in a companion MRL report [14], which provides the essential background for the understanding of the work described here. The modelling of a typical shaped charge using the approach described in this report requires the determination of three phenomenological constants, which are found by fitting to some experimental data for the BRL 105 mm unconfined shaped charge. This process is described in Section 3. In Section 4 we discuss any changes which have to be made to these constants to enable us to model related shaped charge systems, and we then apply the model to the MRL 38 mm shaped charge. Predictions of the model are compared with the recent experimental results of M.C. Chick [15] and the flash radiographs of D.L. Smith and I.B. Macintyre [4]. The effect of varying both liner thickness and cone angle on the velocity of the jet tip is then investigated. Finally, in Section 5, we discuss additional possible applications of the work described here, and several methods for refining the model.

2. DESCRIPTION OF EQUATIONS

Before the PER equations can be used to predict the velocities of jet and slug an expression must be found for the velocity imparted to the liner by the explosive loading. This velocity is characterized by its speed V_0 and the angle δ between the velocity vector \underline{V}_0 and the perpendicular to the original liner surface at each point along its length. These two variables are related by the Taylor equation [20], which for steady state conditions is

$$\sin \delta = V_0/2U \quad (1)$$

where $U = U_D / \cos \alpha$, U_D is the velocity of detonation, and α is the cone half angle. Equation (1) assumes steady state detonation in the direction of the charge axis. It has been generalized to non steady conditions by Chou et al [16], but we shall not be concerned with this here.

As described in a previous report [14], there are basically two approaches to the determination of V_o . We can calculate the bending angle δ using a form of the Richter equation [17] and then use the Taylor equation to find V_o , or we can first calculate V_o using an advanced Gurney equation [18] and then find δ from equation (1). Both methods were tried for the MRL 38 mm shaped charge and the first method was found to be the simplest in practice for the accuracy required. δ is calculated using an equation of the form

$$\frac{1}{2\delta} = \frac{1}{\phi_o} + K\rho \left(\frac{\epsilon}{e} \right), \quad (2)$$

where ρ and ϵ are the density and thickness of the liner material and e is the thickness of the explosive. ϕ_o and K are phenomenological constants which are found by fitting to a well characterized BRL 105 mm shaped charge. This is described in the next section. Equation (2) is the Richter equation as modified by Defourneaux, and more information on this can be found in reference [19]. Harrison [6] also has modified equation (2) to take into account the effect of different case confinements. As the BRL 105 mm is unconfined and the MRL 38 mm only lightly confined it is assumed here that this correction can be neglected.

Once V_o and δ have been calculated the PER equations can be used to calculate the collapse angle β and the velocities and masses of jet and slug. To calculate β a modification of the original PER equation is used. The modified expression is

$$\tan \beta = \tan(\beta^+ + \Delta\beta), \quad (3)$$

where $\Delta\beta$ is defined by

$$\tan \Delta\beta = - (x \sin \alpha / \cos(\alpha + \delta) \cos \delta) (V_o' / V_o) \quad (4)$$

β^+ is the collapse angle which is applicable in the steady state case and was first calculated by Birkhoff, MacDougall, Pugh and Taylor [20]. This is given by

$$\beta^+ = 2\delta + \alpha \quad (5)$$

x is a measure of distance along the cone axis from the apex and the prime denotes differentiation with respect to x . Equation (3) was recently derived by Hirsch [21].

Once β has been calculated the velocities of each element of jet and slug are calculated from

$$V_j = V_o \cos(\alpha + \delta - \beta/2) / \sin(\beta/2) \quad (6)$$

$$V_s = V_o \sin(\alpha + \delta - \beta/2) / \cos(\beta/2), \quad (7)$$

and the masses from

$$m_j/m = \sin^2(\beta/2) \quad (8)$$

$$m_s/m = \cos^2(\beta/2), \quad (9)$$

where m is the liner mass per unit length. These equations were originally derived by Pugh, Eichelberg and Rostoker [5] and are discussed in detail in reference [14].

When modelling both the BRL 105 mm and MRL 38 mm shaped charges it was found necessary to take account of the inverse velocity gradient effect, (IVG). This was not included in the original PER equations but has been discussed in detail by Carleone et al [22]. Here the effect is modelled by assuming that the velocity of each liner element after being hit by the detonation wave has the following form

$$V = V_o (1 - \exp(-(t - T)/\tau)), \quad (10)$$

where V is the velocity at any instant, V_o is the final velocity, T is the time at which the detonation front reaches the element, and τ is a time constant (yet to be determined) for the acceleration. Whilst equation (10) is obviously incorrect for very small times, its overall applicability for liner motion has been amply justified by Chou et al [16].

The calculations described in this report assume that the velocity of the jet tip has already been experimentally determined. This quantity, together with the velocity of detonation U_D and the cone half angle α , are sufficient to give initial estimates of V_o , δ and β using the original steady state equations of Birkhoff et al, i.e. equations (1), (5) and (6). These equations can be solved to give the following expression for V_o

$$\frac{V_o}{2U} = \frac{\tan(\alpha/2)}{(\tan^2(\alpha/2) + (\frac{2U}{V_j} - 1)^2)^{1/2}} \quad (11)$$

Equation (1) is then used to calculate δ , and then equation (5) used to calculate β .

The calculation starts by dividing the shaped charge liner into NN segments, where NN is typically 30 or 40. The bending angle for each element is calculated from equation (2), V_o is calculated from equation (1), and then the collapse angle β is calculated from equation (3). At this stage various other quantities of interest are also calculated. These include T^* , which is the time it takes an element of the liner to reach the axis after being hit by the detonation wave, \bar{z} , which is the point along the liner axis at which each element collides to form jet and slug, and DIST, which is the distance each element travels before hitting the axis. \bar{z} and DIST are given by

$$\bar{z} = x(1 + \tan\alpha \tan(\alpha + \delta)) \quad (12)$$

$$\text{DIST} = x \tan\alpha / \cos(\alpha + \delta) \quad (13)$$

These expressions were first given by Carleone and Chou [23].

The IVG effect is now included by assuming that each element has a velocity given by equation (10). The position as a function of time for each element is now calculated until the distance travelled equals DIST. At this stage T^* is reset to the current time and V_o is reset to the current V . A new δ is calculated from equation (1) and then a new β from equation (3). V_j is then calculated from equation (6) and slower leading jet elements are allowed to collide assuming perfectly plastic impacts. The equilibrated jet tip velocity is then calculated from conservation of mass and momentum.

In the next section we describe the application of this approach to the BRL 105 mm unconfined shaped charge.

3. DETERMINATION OF PHENOMENOLOGICAL CONSTANTS

Before using the scheme outlined in the previous section to model the MRL 38 mm shaped charge we have to determine the constants, K , ϕ_o and τ . As in any phenomenological theory these are found by fitting to experimental data. Because the BRL 105 mm unconfined shaped charge has been studied so extensively, and because of its apparent scaling to the MRL shaped charge, it was decided to use the available data on this charge to determine the constants.

The dimensions of the charge are depicted in Fig. 1. For modelling purposes the true charge geometry is replaced by the pointed cone shown by the dashed line in Fig. 1. The radius is taken to be 43.2 mm and the thickness of the copper liner to be 2.7 mm. The velocity of detonation in the Comp. B is 7.98 mm/ μ s and the experimental value for the velocity of the jet tip is 7.0 mm/ μ s. All data have been taken from [6]. Fig. 2 shows the experimental values for V_j and V_o as a function of scaled length of the cone. Also shown is the theoretical fit to this data using the BRL one-dimensional BASC code of Harrison [6]. The experimental points are from the work of Allison and Vitali [24]. Fig. 3 shows the experimental values for cumulative mass of jet versus cumulative mass of cone and also the BASC code prediction. As can be seen, even though the shapes are similar, there is considerable discrepancy between theory and experiment.

To model this shaped charge using the ideas outlined in the previous section we begin by arbitrarily choosing values for K and ϕ_o and then comparing the resulting V_j and V_o values with the experimental results. After a period of trial and error the values $K = 1.5$ and $\phi_o = 28^\circ$ were decided upon. These give a reasonable fit to the V_j and V_o data, as shown in Fig. 4, and also quite good agreement with the BASC result for the cumulative mass of jet versus cumulative mass of cone, as shown in Fig. 3 by the solid curve labelled $\tau = 0$.

The next step is to include the IVG effect. This is done by choosing τ to have the value 1.0 and then slowly increasing this value until better agreement is obtained with the experimental results. Fig. 5 shows the effect on V_o when $\tau = 2.5$. The IVG effect has reduced the value of V_o near the apex of the cone so that it now agrees with the BASC result, although there is still quite a discrepancy with experiment. By increasing τ to 8.0 this discrepancy is reduced to an acceptable level, as can also be seen from Fig. 5. For $\tau = 8.0$ the equilibrated jet tip velocity is 7.0 mm/ μ s, in good agreement with the experimental results, and the plot of cumulative mass of jet versus cumulative mass of cone also shows much better agreement with experiment. This is shown in Fig. 3.

The level of agreement between theory and experiment shown here suggests that the BRL 105 mm unconfined shaped charge is satisfactorily modelled by the scheme outlined in the previous section with the values of the constants just given. We note also that this level of agreement is independent of the number of segments into which the shaped charge is initially divided. In the next section we apply this approach to the MRL 38 mm shaped charge.

4. APPLICATION TO MRL 38 MM SHAPED CHARGE

The dimensions and composition of the MRL shaped charge are shown in Fig. 6. For modelling purposes we take the radius of the liner to be 19.1 mm with a thickness of 1.02 mm. The velocity of detonation in the Australian

Comp. B is 7.76 mm/ μ s [31] and the best experimental value for the velocity of the jet tip is 7.33 mm/ μ s [4].

Before proceeding further we now have to examine how the three phenomenological constants scale with the size and type of shaped charge under consideration. Equation (2) was originally derived for planar geometries. Under these conditions K and ϕ depend only on the particular explosive/metal combination and are independent of size. Both Defourneaux [19] and Harrison [6] point out that ϕ does depend on the angle of inclination of the detonation wave to the metal surface, but as the liner half-angle is 21° for both the BRL 105 mm and MRL 38 mm shaped charges this is of no concern to us. The application of equation (2) to the curved geometry of shaped charges is rather outside the scope of its initial derivation, but this approximation has been used now in many papers on shaped charge modelling and the results have indicated its applicability in this area. We conclude then that the values of the constants K and ϕ derived for the BRL 105 mm shaped charge should also be applicable to the MRL 38 mm shaped charge, although the smaller run-distance to the apex of the cone may affect the impulse delivered to the liner and therefore have a slight effect on the constants. This is currently under investigation [27]. The smaller run-distance will also mean that the detonation front is not perfectly planar and so the angle of inclination will not be exactly 21° , but the effect of this on the constants K and ϕ is expected to be very small.

The question with regard to τ is less clear. τ does in fact vary with position along the liner and Chou et al [16] give expressions for this in their paper. Our τ is position independent and is an integrated form of the one used by them, and consequently its dependence on the overall size of the shaped charge is harder to predict. For the moment we simply regard τ as a free parameter to be fixed by requiring that the equilibrated jet tip velocity be equal to the experimental jet tip velocity. This results in a value for τ of 2.3 μ s.

The predictions of this modelling scheme when applied to the MRL shaped charge are now described. Fig. 7 shows the velocity gradient within the jet before equilibration of the jet particles has occurred. The liner was initially divided into 30 segments for this calculation, but the result is independent of the number of segments chosen. The inverse velocity gradient effect is clearly evident, and calculations allowing fully plastic impact of the jet particles show that material from the first ten segments of the cone collide to form a compact jet tip particle with a mass of 0.27 g. The data contained in Fig. 7 are replotted in Fig. 8 after equilibration of the jet tip velocity to show the velocity gradient within the jet as a function of the scaled length of the jet. Also shown in Fig. 8 are experimental values for the velocity gradient obtained from recent experiments by M.C. Chick at MRL [15]. These were obtained by taking flash radiographs of the jet after it had broken up into a number of small segments. The velocity of each segment was then obtained by measuring the distance it had travelled between two X-ray flashes. Unfortunately the X-ray cassettes were not large enough to measure all of the jet particles produced and so an estimate of the total number had to be made. Several BRL reports (such as [25,26]) have noted that the number of particles into which a jet will break is independent of the size of the shaped charge and depends only on the explosive, provided all dimensions are

scaled appropriately. For a copper lined shaped charge with a 21° half angle and Comp. B explosive the jet breaks into about 50 particles having velocities within the range $V_{j(\text{tip})}$ (approximately 7.5 mm/ μ s) down to 2.0 mm/ μ s. Particles with velocities less than 2.0 mm/ μ s are also produced close to the back of the jet, but these are not counted by BRL as they are incapable of penetrating a target [25]. With the above in mind, a plot of particle velocity versus particle number was made for the data obtained by M.C. Chick. This is shown in Fig. 9. A maximum number of 38 jet particles could be counted for this particular set of experiments and the velocity of the slowest particle measured was approximately 4 mm/ μ s. A straight line drawn through the data and then extrapolated back to a particle velocity of 2 mm/ μ s indicates a particle number of 55, which is in good agreement with the BRL data as the 38 mm shaped charge may be too small for exact scaling to apply. The velocity of the tail end of the jet predicted from Fig. 8 is 0.18 mm/ μ s and from Fig. 9 this corresponds to 72 particles. Assuming this is the total number of particles produced in the breakup of the jet we can then plot the experimental fragment velocities as a function of the scaled length of the jet as shown in Fig. 8. The level of agreement between experiment and the prediction of the model is quite pleasing considering the uncertainty involved in analysing the experimental data and the simplicity of the model. Obviously this agreement depends fairly strongly on the estimate of the total number of particles produced on jet breakup, and further experiments are planned to enable this number to be determined much more accurately [27].

We now consider the collapse angle β as a function of time ($t = 0$ corresponding to the firing of the detonator). Fig. 10 shows the prediction of the model and a comparison with the experimental results obtained by D.L. Smith and I.B. Macintyre [4]. It should be noted that the estimation of these collapse angles from the flash radiographs is a particularly difficult measurement to make, and is subject to appreciable error because of the difficulty in estimating the position of the inner edge of the liner. The results shown in Fig. 10 were obtained by D.L. Smith and I. Macintyre [4] using image enhancement techniques and are probably the best which can be obtained, but even so the measurements of the larger angles are subject to such large uncertainties that they have not been included here. The agreement between theory and experiment is again quite acceptable considering the simplicity of the model and the experimental errors.

The above results indicate that the equations described in Section 2 provide a realistic model for linear collapse and jet formation in the MRL 38 mm shaped charge, and so we can now use this model to investigate various parametric dependencies. For example, Fig. 11 shows the effect of varying the cone half angle α on jet tip velocity. The dashed line has been calculated using the simple steady state theory of Birkhoff et al [20], while the full line has been calculated using the present model. The dots represent experimental values obtained by BRL for their 1-1/2 inch diameter copper lined shaped charge with Comp B explosive [26]. The experimental points show that as the cone half angle α increases then $V_{j(\text{tip})}$ decreases. This trend is predicted both by the steady state theory and the model developed here, with the latter giving better agreement with the experimental values as α increases from 10° to 30° . Beyond this value of α the model predicts that $V_{j(\text{tip})}$ becomes almost constant, while the simple theory predicts a continuous decrease in $V_{j(\text{tip})}$. The reason for this is that as α increases each element on the liner near the apex of the cone has a greater distance to travel and is

therefore able to obtain a greater fraction of its terminal velocity before colliding on the axis. This increase in element velocity on hitting the axis balances the decrease in $V_{j(\text{tip})}$ due to the changing geometry and so $V_{j(\text{tip})}$ remains approximately constant. The experimental point at $\alpha = 45^\circ$ shows that $V_{j(\text{tip})}$ does indeed not decrease as much as predicted by the simple theory, but it does decrease and not remain constant. The reason for the failure of the model in this region is because of the neglect of the dependence of the constants K and ϕ in equation (2) on the angle of inclination of the detonation wave to the liner, i . Fig. 2 of reference [6] shows that as i decreases (i.e. α increases) both K and ϕ become rapidly varying functions of i . The model can be fitted to the experimental point at $\alpha = 45^\circ$ simply by changing ϕ from 28° to 20° , which is in agreement with the trend shown in Fig. 2 of Reference [6].

The model could also be used to investigate other parametric dependencies, such as the variation of $V_{j(\text{tip})}$ with the thickness of the liner. Here it would first be important to find the dependence of τ on the thickness of the liner, and this could be done either by analysing the trends from some of the BRL data, or using a code such as 2DL [11] to explicitly calculate τ for various liner thicknesses (and also for different explosives). An application of the model to wave shaping in the MRL shaped charge has just been completed and will be reported elsewhere [32].

5. CONCLUDING REMARKS

A simple model of liner collapse and jet formation for the MRL 38 mm shaped charge has been described and the predictions of the model have been found to compare favourably with recent experimental results. The model could obviously be improved in several ways if more accuracy was required, and two of these options are now described:

(i) The calculation of the impulse exerted on the liner by the detonation wave could be made using an improved Gurney model of the type described by Chanteret [18] or Hennequin [28].

This would have the advantage of using known physical constants for the particular explosive/liner combination and would not require fitting to phenomenological constants such as K and ϕ . An even more sophisticated method of calculating liner impulse would be to use a 2D code such as HEMP or 2DL to provide the values of V_0 and δ to feed into the present model. Such an approach has been used by Van Thiel and Levitan [29].

(ii) The modelling of the jet tip could be improved and a plotting program could be written to draw the outline of the jet, slug, and liner at selected times. The simplest way to do this would be to assume that the accumulated segments in the jet tip form a spherical blob, but already we know that this is not a very accurate description of the process. The jet tip appears flattened along its leading edge, and there is evidence that ablation has a significant effect on the shape of the jet tip. It would be of interest

to understanding this formation process in more detail, however, because of its obvious relevance to the jet initiation work of M.C. Chick [2].

Other possible improvements are the incorporation of the non steady Taylor angle formulation of Chou et al [16], and the inclusion of compressibility along the lines described by Chou, Carleone and Karpp [30]. In its present form the model describes experimental observations well and has demonstrated good capabilities for parametric studies, thus further refinement would have to be justified by more detailed experimental characterisation of shaped charges.

6. ACKNOWLEDGEMENTS

I would like to thank F.G.J. May for much useful advice and guidance on the behaviour of shaped charges, and D.L. Smith, M.C. Chick and I. Macintyre for making available to me their recent experimental results.

I thank M. Fitzgerald and E.D. Northeast for computational assistance.

7. REFERENCES

1. Chick, M.C. and Briggs, G.P. "Fabrication and Performance Assessment of Shaped Charges", MRL Report No. 546, June 1974.
- 2a. Chick, M.C. and Macintyre, I.B. "The Jet Initiation of Solid Explosives", Eighth Symposium (International) on Detonation. Preprints, p.20, Albuquerque, NM, USA, July 1985.
- 2b. Chick, M.C. and Hatt, D.J. "Metal Jet Initiation of Bare and Covered Explosives; Summary of the Mechanism, Empirical Model and some Applications". MRL-R-830, October 1981.
3. "HELP - A Multimaterial Eulerian Program in Two Space Dimensions and Time", L.J. Hageman et al, Systems, Science and Software. Final Report AFATL-TR-76-45, April 1976.
4. Smith, D.L. and Macintyre, I.B. MRL Report to be published.
5. Pugh, E.M., Eichelberg, R.J. and Rostoker, N. "Theory of Jet Formation by Charges with Lined Conical Cavities". J. Appl. Physics 23, 532-542 (1952).
6. Harrison, J.T. "BASC, An Analytical Code for Calculating Shaped Charge Properties". 6th Int. Symp. on Ballistics, October 1981.
7. Carleone, J., Chou, P.C. and Tanzio, C.A. Dyna East Corp. Tech. Rep. DE-TR-75-4 (1975).
8. Cullis, I.G. RARDE, Private Communication, 1983.
9. Hennequin, E., Pfeffer, G. and Winaver, A. "Numerical Simulation of Shaped Charge Detonation". 3rd Int. Symp. on Ballistics, 1977.
10. Carleone, J., Chou, P.C. and Simpson, R. "A Synthesis Model for Modern Warhead Design", 4th Int. Symp. of Ballistics, October 1978.
11. "2DL: A Lagrangian Two-Dimensional Finite-Difference Code for Reactive Media". J.N. Johnson, C.L. Mader and M.S. Shaw, Los Alamos Report LA-8922-M-UC-32, August 1981.
12. HULL Computer Code. BRL Private Communication, 1982.
13. "Calculation of Elastic-Plastic Flow". Mark L. Wilkins, Lawrence Livermore National Laboratory, UCRL-7322, Rev. 2, Preprint, February 1982.
14. Jones, D.A. "A Review of One Dimensional Shaped Charge Theory Part 1 - Jet Formation", MRL Report, MRL-R-940, November 1984.
15. Chick, M.C. Unpublished work, January 1985.

16. Chou, P.C., Carleone, J., Hirsch, E., Flis, W.J. and Ciccarelli, R.D. "Improved Formulas for Velocity, Acceleration and Projection Angle of Explosively Driven Liners". Proceedings of 6th Int. Symp. on Ballistics, pp 262-272, October 1981.
17. Richter, H. "On the theory of shaped charges: Motion of thin liners of plastic material on the surface of a plane explosive", Note Technique ISL No. 6a/48 (1948).
18. Chanteret, P.Y. "An Analytical Model for Metal Acceleration by Grazing Detonation", Proceedings of the 7th International Symposium on Ballistics, April 1983, p 515.
19. Defourneaux, M. "Theorie Hydrodynamique des Charges Creuses", Memorial del'Artillerie Francaise, T. 44 2^c Fasc., pp 293-334, 1970.
20. Birkhoff, G., MacDougall, D.P., Pugh, E.M. and Taylor, G. "Explosives with Lined Cavities", J. Appl. Physics 19 563-582 (1948).
21. Hirsch, E. "A Simple Representation of the Pugh, Eichelberger and Rostoker Solution to the Shaped Charge Jet Formation Problem". J. Appl. Physics 50 4667 (1979).
22. Carleone, J., Jameson, R. and Chou, P.C. "The Tip Origin of a Shaped Charge Jet", Propellants and Explosives 2, 126-130 (1977).
23. Carleone, J. and Chou, P.C. "A One-Dimensional Theory to Predict the Strain and Radius of Shaped Charge Jets", Proceedings of 1st Int. Conf. on Ballistics, November 1974, Orlando, Florida.
24. Allison, F.E. and Vitali, R. "An Application of Jet-Formation Theory to a 105 mm Shaped Charge". BRL Report No. 1165, March 1962.
25. Di Persio, R., Simon, J., Martin, T.H. "A Study of Jets from Scaled Conical Shaped Charge Liners", BRL Report No. 1298, August 1960.
26. Di Persio, R., Jones, W.H., Merendino, A.B. and Simon, J. "Characteristics of Jets from Small Caliber Shaped Charges with Copper and Aluminium Liners", BRL Memorandum Report No. 1866, September 1967.
27. M.C. Chick. Personal communication, May 1985.
28. Hennequin, E.M. "Analytical Model of the Shaped Charge Liner Collapse", Proceedings of the 7th International Symposium on Ballistics, April 1983, p 515.
29. van Thiel, M. and Levitan, J.A. "Jet Formation Experiments and Computations with a Lagrange Code", J. Appl. Phys. 51 6107 (1980).
30. Chou, P.C., Carleone, J. and Karpp, R.R. "Criteria for Jet Formation from Impinging Shells and Plates". J. Appl. Phys. 47 2975 (1976).

31. Jenks, G.J., Masinskas, J.J. and Price, D.A. "Detonation Parameters for Australian High-Explosives Composition", MRL-R-882, May 1983.
32. Jones, D.A. "Wave Shaping in the MRL 38 mm Shaped Charge" MRL Report - submitted (1985).

M36A1 ELECTRIC DETONATOR

TETRYLBOOSTER PELLET

COMPOSITION B

COPPER LINER

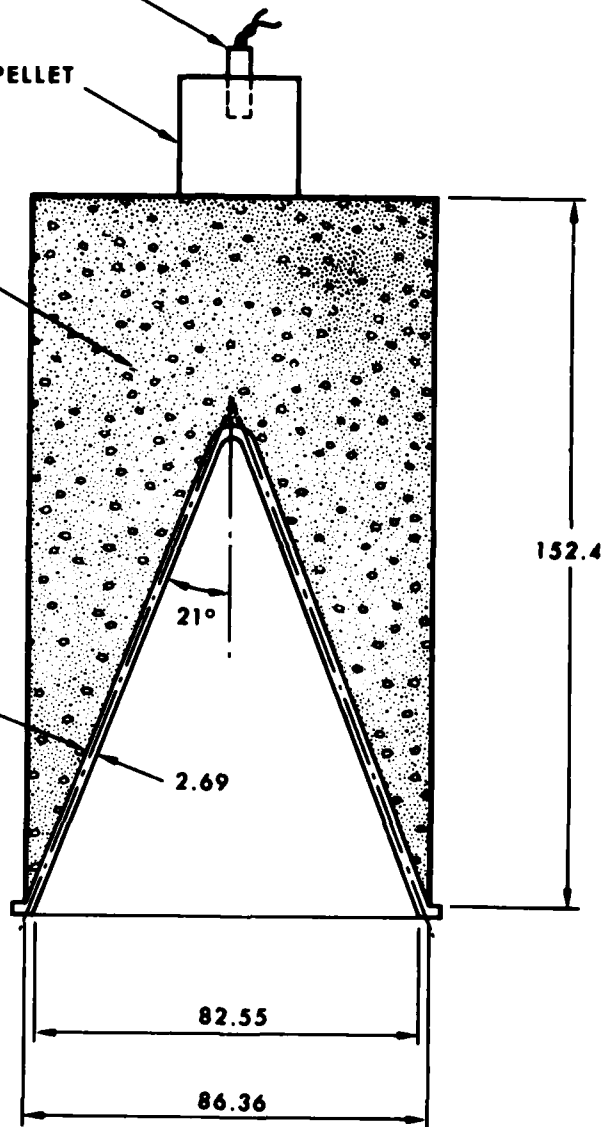

FIGURE 1 The BRL 105 mm unconfined shaped charge. All lengths in mm.

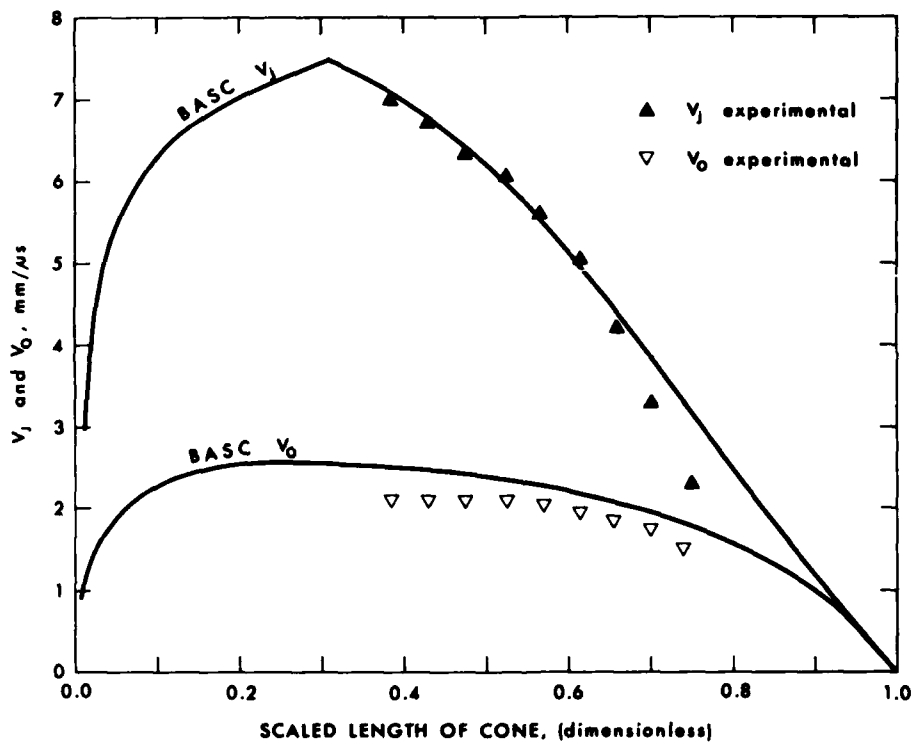

FIGURE 2 Experimental values for V_j and V_o for the BRL 105 mm shaped charge. The solid lines are the predictions of the BASC code.

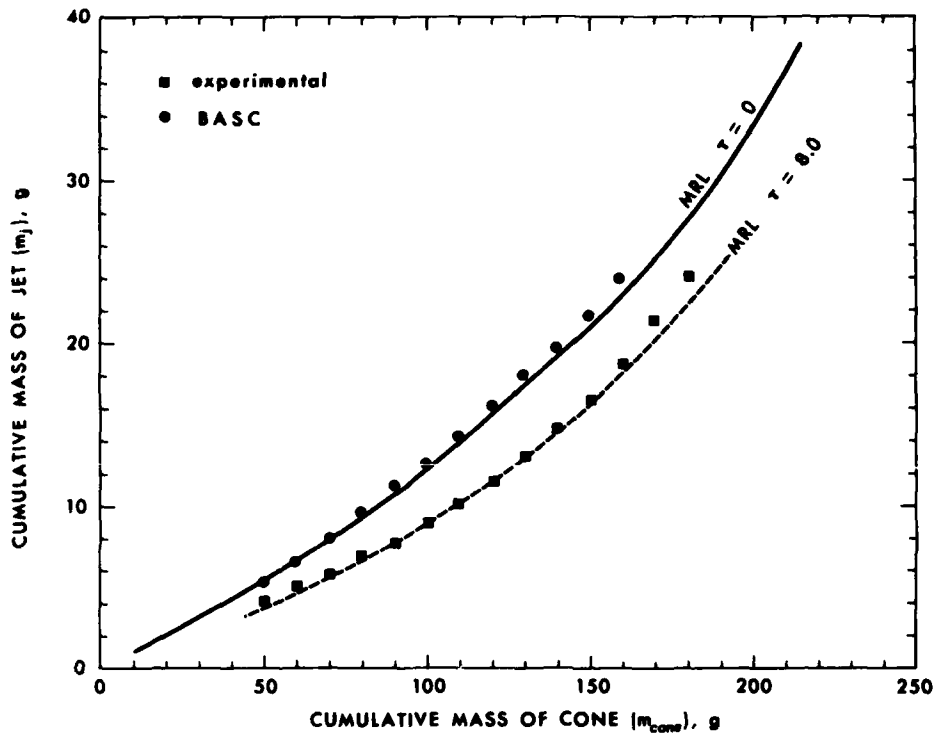

FIGURE 3 Cumulative mass of jet versus cumulative mass of cone for the BRL 105 mm shaped charge. The squares are the experimental values while the circles are the predictions of the BASC code. The solid line is the result predicted by the MRL model without inclusion of the inverse velocity gradient effect, while the dashed line is the prediction when this effect is included, with $\tau = 8.0$.

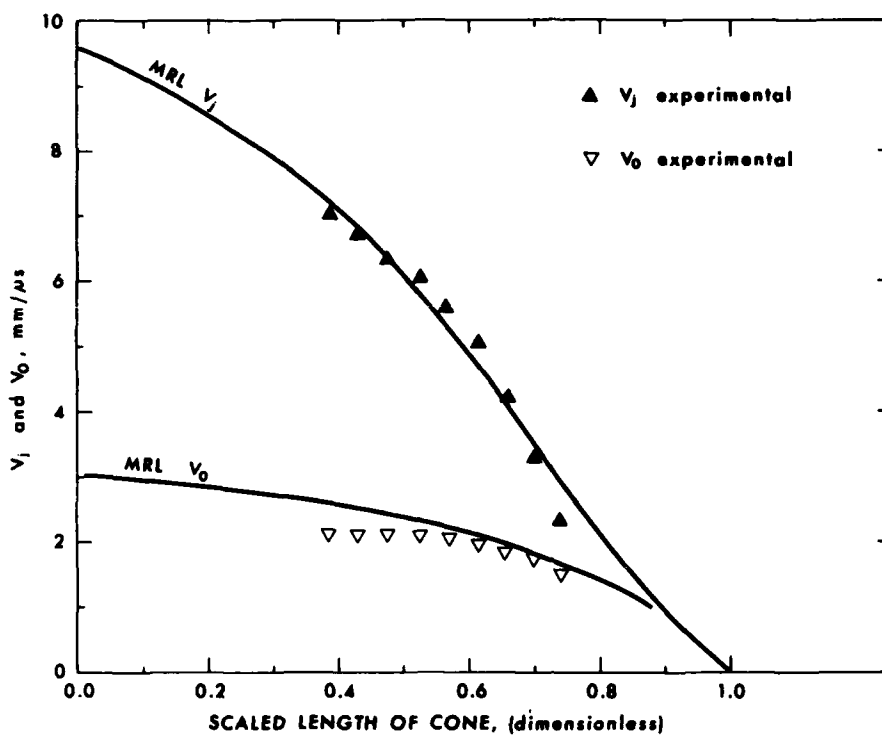

FIGURE 4 Experimental values for V_j and V_0 for the BRL 105 mm shaped charge. The solid lines are the predictions of the MRL model without inclusion of the inverse velocity gradient effect, for $K = 1.5$ and $\phi_0 = 28^\circ$.

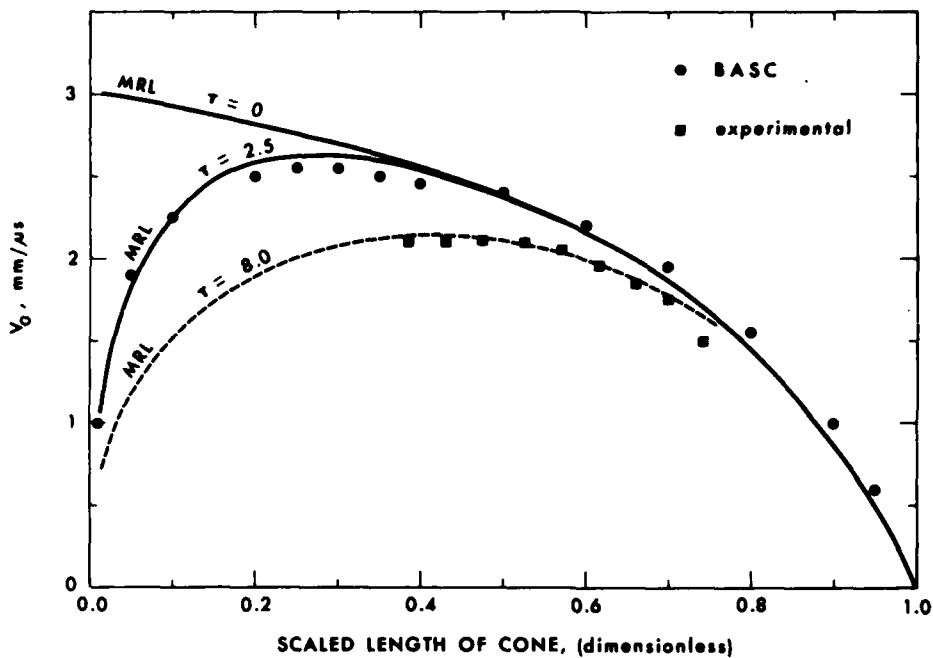

FIGURE 5 V_0 values for the BRL 105 mm shaped charge. The squares are the experimental values and the circles the BASC code prediction. The solid line labelled $\tau = 0$ is the prediction of the MRL model without inclusion of the inverse velocity gradient effect, while the dashed line includes the effect, with $\tau = 8.0$.

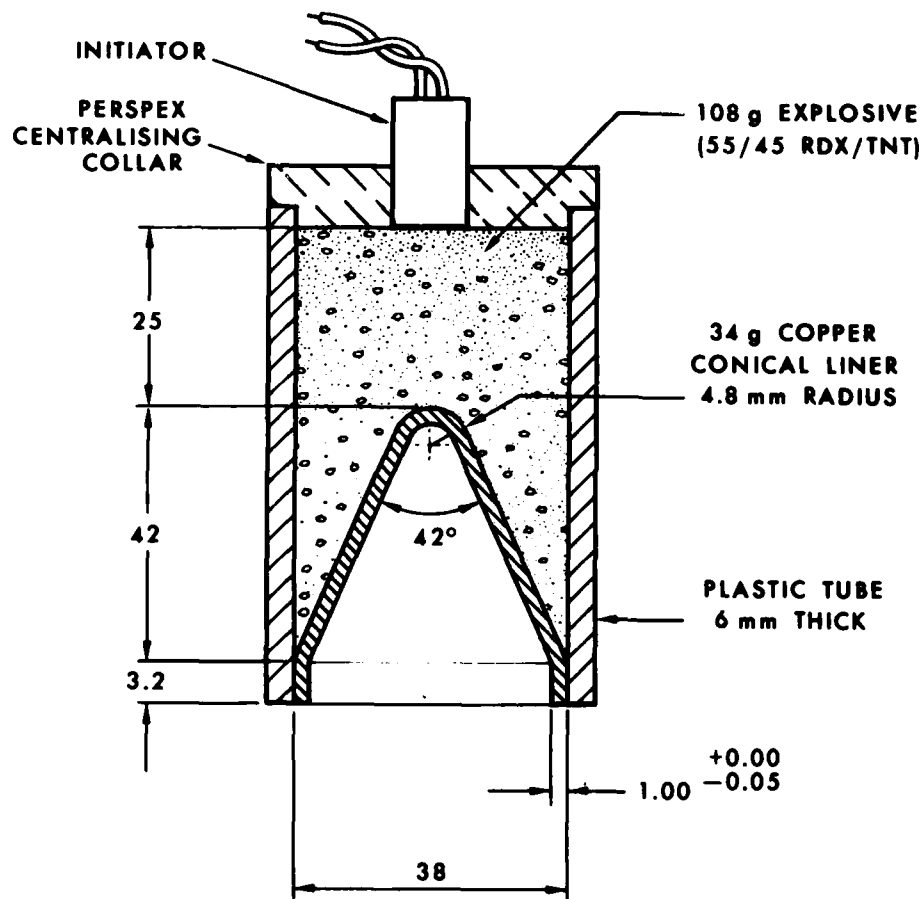

FIGURE 6 The MRL 38 mm shaped charge. All lengths in mm.

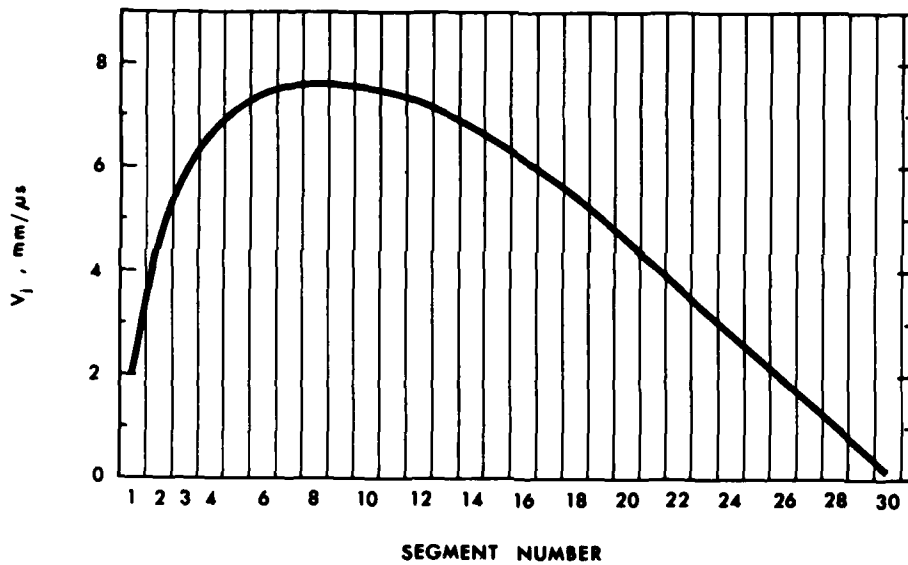

FIGURE 7 Velocity gradient within the MRL jet before equilibrium of jet particles has occurred.

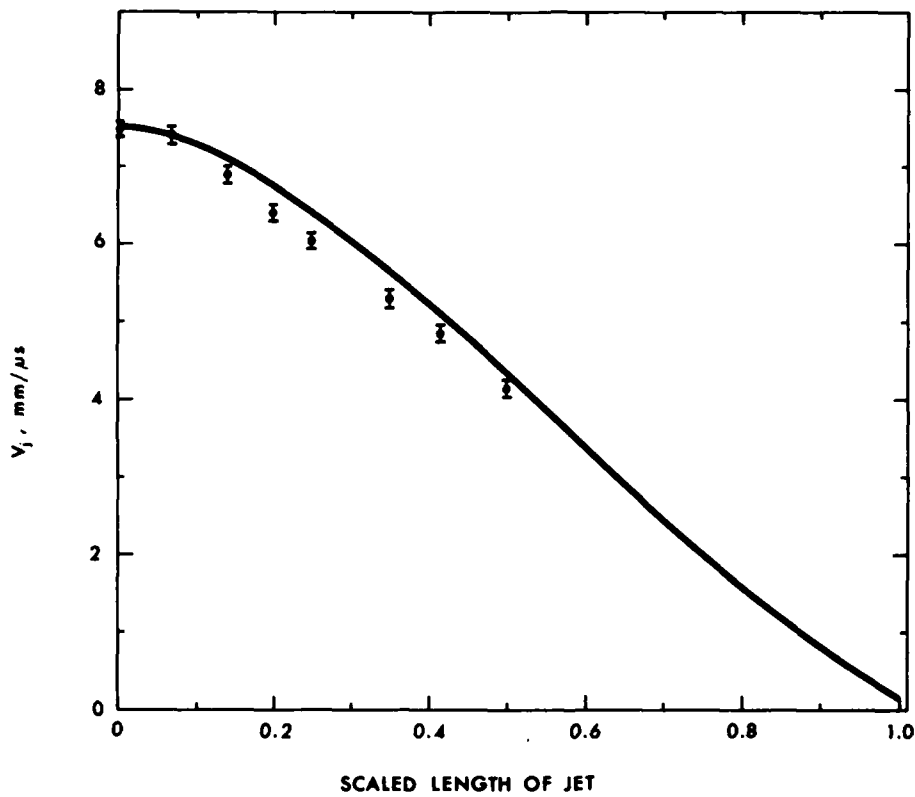

FIGURE 8 Velocity gradient within the MRL jet as a function of scaled length of jet. The solid line is the prediction of the model, the experimental points are from recent work by M.C. Chick [15].

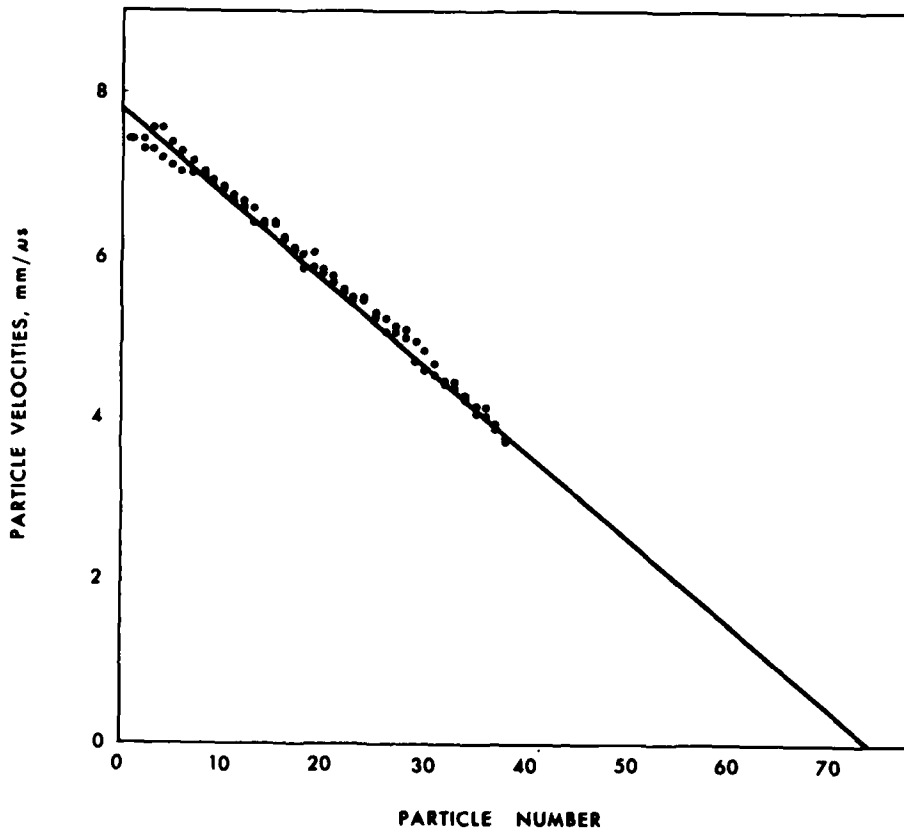

FIGURE 9 Particle velocity versus particle number for the MRL jet after breakup. The different data points represent two experiments from recent work by M.C. Chick [15].

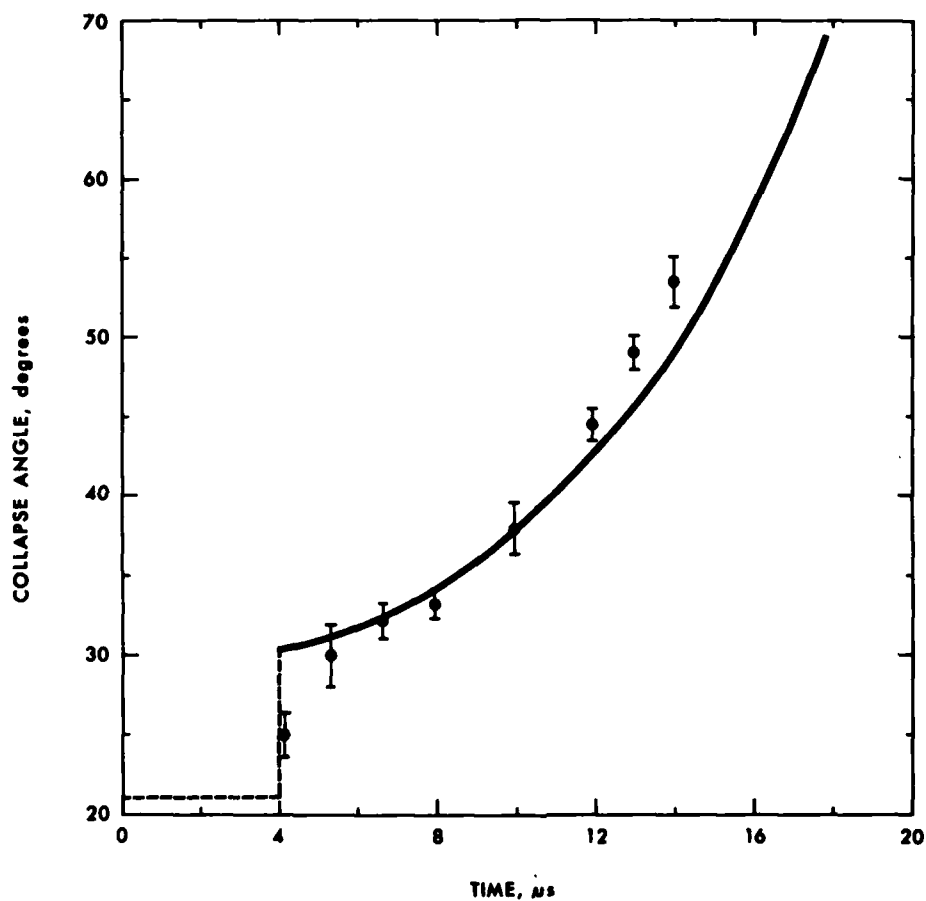

FIGURE 10 Collapse angle β for the MRL shaped charge as a function of time after firing the detonator. The solid curve is the prediction of the model, the experimental points are from recent work by D.L. Smith and I.B. Macintyre [4]. The dashed line represents the time taken by the detonation wave to travel from the detonator to the cone apex.

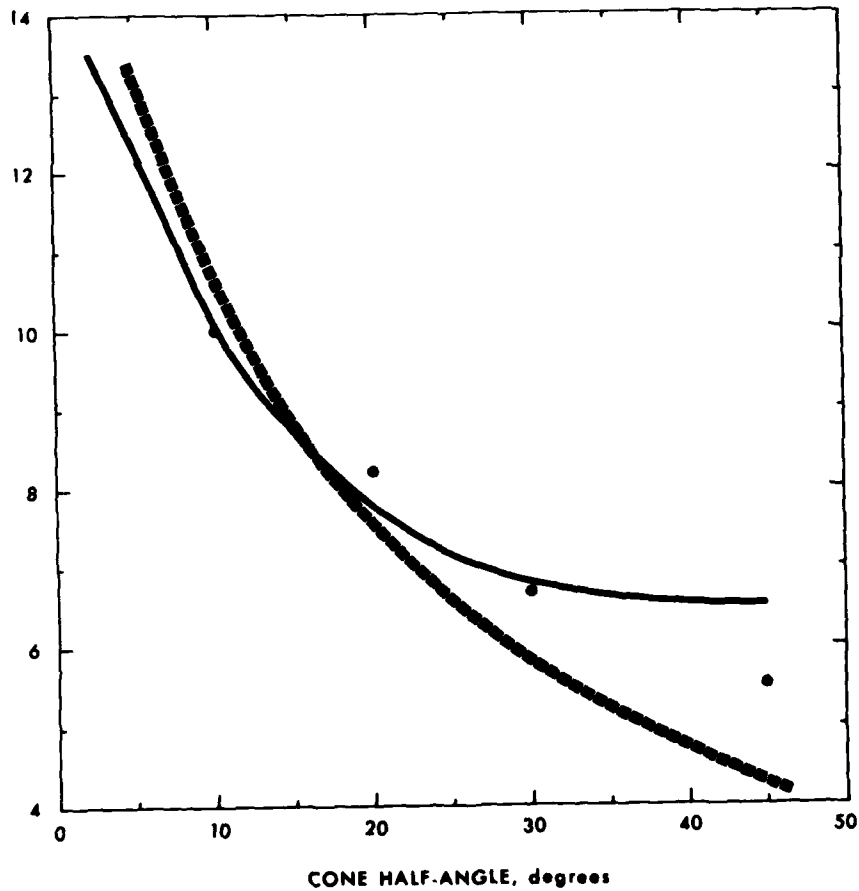

FIGURE 11 Velocity of jet tip as a function of cone half angle. The dashed line has been calculated from the steady state theory of Birkhoff et al [20], the solid line is the prediction of the model, and the circles are experimental points from some BRL work [26].

END

FILMED

386

DTIC