

AD-A164 425

AUTOMATED SYSTEM FOR RESOLVING THE POSITION OF SOLAR  
RADIO BURSTS(U) AIR FORCE GEOPHYSICS LAB HANSCOM AFB MA  
D N GAUNT 19 AUG 85 AFGL-TR-85-0179

1/1

UNCLASSIFIED

F/G 3/1

NL



			END
			FILED
			14
			SEP

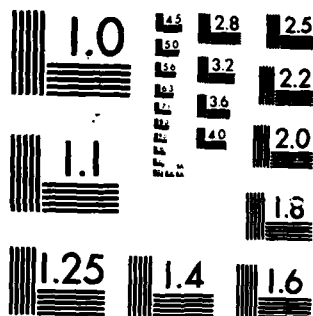

MICROCOPY RESOLUTION TEST CHART  
NATIONAL BUREAU OF STANDARDS-1963-A

12

AFGL-TR-85-0179  
INSTRUMENTATION PAPERS, NO. 330

AD-A164 425

# Automated System for Resolving the Position of Solar Radio Bursts

DAVID N. GAUNT

DTIC  
ELECTE  
FEB 21 1986  
S D



19 August 1985



Approved for public release; distribution unlimited.



DTIC FILE COPY



SPACE PHYSICS DIVISION

PROJECT 2311

**AIR FORCE GEOPHYSICS LABORATORY**

HANSCOM AFB, MA 01731

86 2 21 016

This technical report has been reviewed and is approved for publication.

FOR THE COMMANDER



E.G. MULLEN, Chief  
Space Particles Environment Branch  
Space Physics Division



RITA C. SAGALYN, Director  
Space Physics Division

This document has been reviewed by the ESD Public Affairs Office (PA) and is releasable to the National Technical Information Service (NTIS).

Qualified requestors may obtain additional copies from the Defense Technical Information Center. All others should apply to the National Technical Information Service.

If your address has changed, or if you wish to be removed from the mailing list, or if the addressee is no longer employed by your organization, please notify AFGL/DAA, Hanscom AFB, MA 01731. This will assist us in maintaining a current mailing list.

Unclassified

AD-A164425

SECURITY CLASSIFICATION OF THIS PAGE

REPORT DOCUMENTATION PAGE					
1a REPORT SECURITY CLASSIFICATION Unclassified		1b RESTRICTIVE MARKINGS			
2a SECURITY CLASSIFICATION AUTHORITY		3 DISTRIBUTION/AVAILABILITY OF REPORT Approved for public release; Distribution unlimited.			
2b DECLASSIFICATION/DOWNGRADING SCHEDULE					
4 PERFORMING ORGANIZATION REPORT NUMBER(S) IP No. 330 AFGL-TR-85-0179		5 MONITORING ORGANIZATION REPORT NUMBER(S)			
6a NAME OF PERFORMING ORGANIZATION Air Force Geophysics Laboratory		6b OFFICE SYMBOL (If applicable) PHP	7a NAME OF MONITORING ORGANIZATION		
6c ADDRESS (City, State and ZIP Code) Hanscom AFB Massachusetts 01731		7b ADDRESS (City, State and ZIP Code)			
8a NAME OF FUNDING SPONSORING ORGANIZATION		8b OFFICE SYMBOL (If applicable)	9 PROCUREMENT INSTRUMENT IDENTIFICATION NUMBER		
8c ADDRESS (City, State and ZIP Code)		10 SOURCE OF FUNDING NOS			
		PROGRAM ELEMENT NO	PROJECT NO	TASK NO	WORK UNIT NO
		61102F	2311	G1	12
11 TITLE (Include Security Classification) Automated System for Resolving the Position of Solar Radio Bursts					
12 PERSONAL AUTHOR(S) David N. Gaunt					
13a TYPE OF REPORT Scientific, Interim.		13b TIME COVERED FROM _____ TO _____	14 DATE OF REPORT (Yr., Mo., Day) 1985 August 19	15 PAGE COUNT 16	
16 SUPPLEMENTARY NOTATION					
17 COSATI CODES			18 SUBJECT TERMS (Continue on reverse if necessary and identify by block number)		
FIELD	GROUP	SUB GR	Sun Interferometry		
3	2	11	Flares Burst position		
3	2	16	Solar radio bursts		
19 ABSTRACT (Continue on reverse if necessary and identify by block number)					
<p>This report describes an effort to design a system which would automatically resolve the position of a solar burst within 1.3 min of arc based on sweep frequency (25 to 75 MHz) observations.</p>					
20 DISTRIBUTION AVAILABILITY OF ABSTRACT UNCLASSIFIED UNLIMITED <input checked="" type="checkbox"/> SAME AS RPT <input type="checkbox"/> DTIC USERS <input type="checkbox"/>			21 ABSTRACT SECURITY CLASSIFICATION Unclassified		
22a NAME OF RESPONSIBLE INDIVIDUAL D. N. Gaunt			22b TELEPHONE NUMBER (Include Area Code) (617) 861-4214	22c OFFICE SYMBOL AFGL/PHP	

DD FORM 1473, 83 APR

EDITION OF 1 JAN 73 IS OBSOLETE

Unclassified  
SECURITY CLASSIFICATION OF THIS PAGE

## Illustrations

1. Functional Diagram of SFIR Source Position Resolver System	2
2. Sweep Interferometer	3
3. Time Base Generator, 10 MHz Divided by 52736 = 0.18962 Hz	4
4. Conversion, Angle to Path Difference	5
5. Fringe Position Detector	7
6. Logic of Fringe Position Detector	8
7. Fringe Read Out	9
8. Resolver for Fringe Position Displacement From Center of Solar Disk Logic	10

## Tables

1. Fringe Measurements Limits	6
-------------------------------	---



iii

Accession For	
NTIS CRA&I	<input checked="" type="checkbox"/>
DTIC TAB	<input type="checkbox"/>
Unannounced	<input type="checkbox"/>
Justification	
By	
Distribution /	
Availability Codes	
Dist	Availability and/or Special
A-1	

## Automated System for Resolving the Position of Solar Radio Bursts

A swept frequency interferometer system such as the one in operation at Sagamore Hill observatory, described in AFGL Tech report 76-0194 1976, contains in its output data, precise information which can determine, in a plane resolution, the position of a radio source on the solar disk within 1.3' arc. This information is the frequency separation between the interference fringes within the spectrum observed. A system which could, automatically, convert this information to degrees and minutes of arc is described here, shown logically in Figure 1.

A radio interferometer is a receiver system consisting of two antennas displaced from one another. The system measures the phase difference of signals received from the antennas. Figure 2 is a functional diagram of a swept frequency interferometer:  $X \sin \theta + d$  will represent alternately, a multiple of one or a half wavelength of the received signal. This causes the phases of the two signals to alternately add and subtract at the point of comparison, the hybrid function. If the receiver sweeps in frequency at a constant rate with respect to time, the result at the output of the receiver will be a sine wave whose amplitude is proportional to that of a discrete source, it's frequency proportional to the sine of angle  $\theta$ . The peaks of this sine wave will be referred to as fringes. In the system at Sagamore Hill observatory, the antennas are separated by 300 m on an east/west line. The receiver sweeps once per second from 25 MHz to 75 MHz.

---

(Received for publication 12 August 1985)

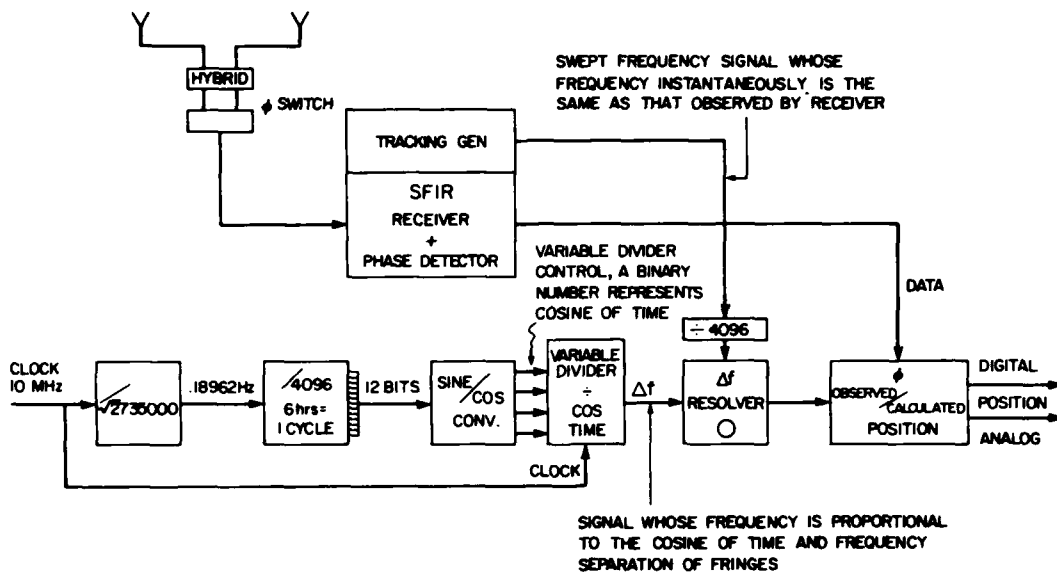

Figure 1. Functional Diagram of SFIR Source Position Resolver System

In the Sagamore Hill configuration the separation of the fringe peaks in the frequency domain and the angle of elevation of the source are related as follows:

$$\Delta f = \left( \frac{300}{\cos \theta} \times 300 \right) + 150$$

$$= \frac{1}{\cos \theta} + 0.5$$

where

- $\Delta f$  = separation of fringes, MHz,
- $\theta$  = elevation of angle of source, degrees,
- 300 = separation of antennas meters,
- 150 = delay line electrical length, meters.



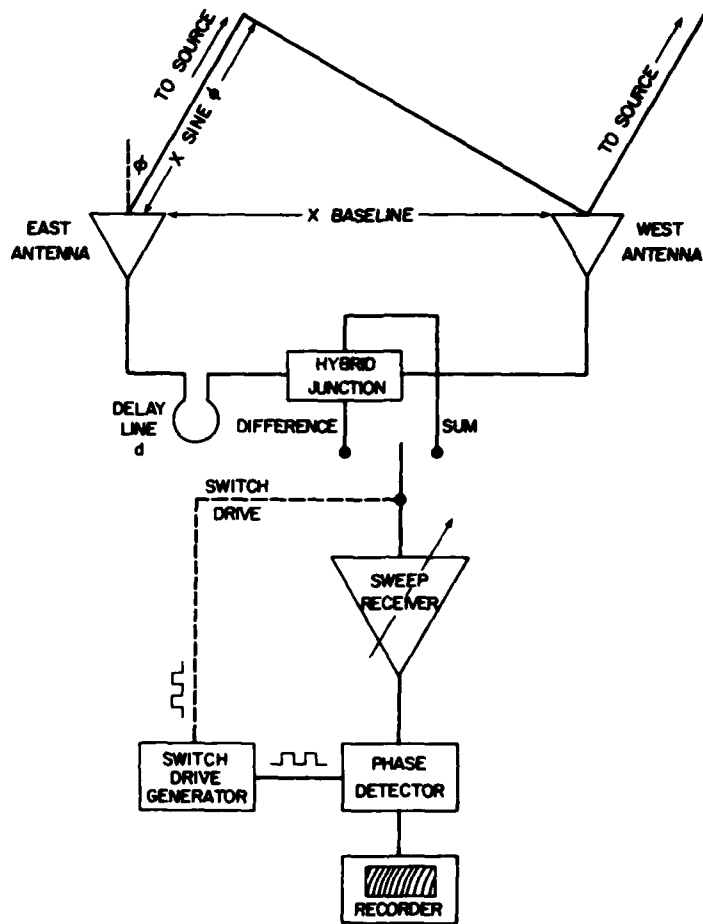

Figure 2. Sweep Interferometer

The angle,  $A$ , between the source (SUN) and the baseline (line between antennas) changes as a linear function of time. In this system the measure of time is derived from a stable 10 MHz oscillator divided down to 0.1896 Hz or 1 pulse every 5.273 sec; the time period in which the sun moves 1.3183' of arc, 1.318' arc is a 12-bit binary derivative of  $180^\circ$ . The 0.1896 Hz or 5.273-sec pulses are used to increment a 14-bit binary counter which counts up to 10,800 in increments equivalent to 1.31831 movement of the sun, totaling  $180^\circ$  or 12 hours of sun travel (see Figure 3).

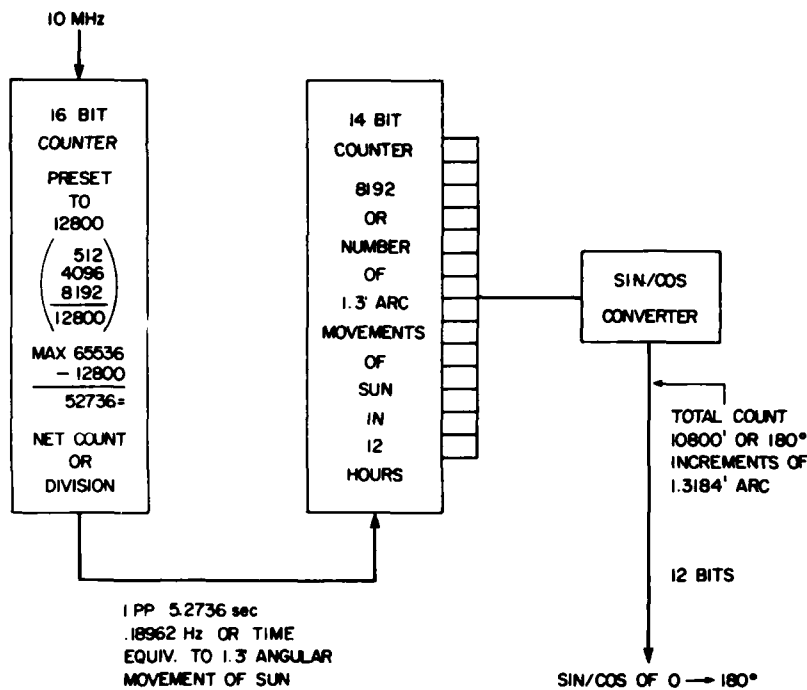
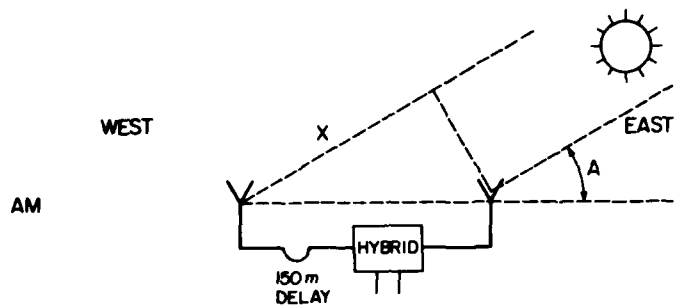

Figure 3. Time Base Generator, 10 MHz Divided by 52736 = 0.18962 Hz

The output of the 10,800 counter, a binary linear representation of time and angle, is converted in the sine/cosine converter to a 12-bit binary representation of the cosine of the angle (TIME), angle A shown in Figure 4. When the angle from baseline to sun is 90° (SUN OVERHEAD) the sign of the cosine changes to a negative value. If we ignore the sign we have the sine of an angle from sun to a plane normal to the baseline. This permits a 12-hour positively incremented measure of time and angle simplifying the process which otherwise would require reversing the count at noon.

The cosine/sine converter, 12-bit output, is used to control, by presetting, a counter counting cycles of the 10-MHz clock. For a source in the center of the solar disk, the output of the counter then is a signal whose frequency is inversely proportional to the path difference between the signals from the antennas and proportional to the frequency whose 1/2 wavelength is a sub-multiple of the path difference.

This signal forms a time base for detecting the points in the receiver frequency sweeps where there would be a fringe peak for a solar disk center emission.



$$\text{(PATH DIFF.) } X = (\cos A \times 300)$$

ADD 150 meters FOR TOTAL PATH DIFF.

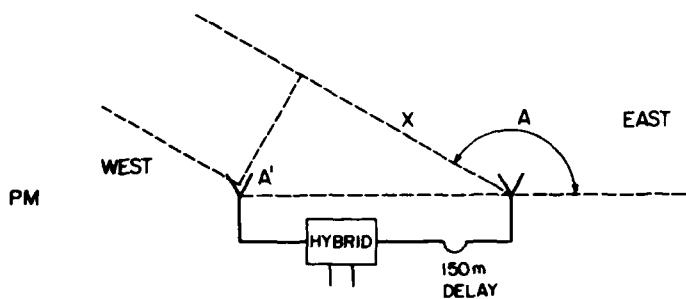

$$\text{(PATH DIFF.) } X = \sin A' \times 300$$

$$\sin A' = -\cos A \quad \text{OR } X = -\cos A \times 300$$

ADD 150 meters FOR TOTAL PATH DIFF.

Figure 4. Conversion, Angle to Path Difference

The frequency of the receiver tuning is derived from a tracking generator which tracks the receiver tuning continuously and produces a signal whose frequency, is at every moment, the same as the receiver tuning as it sweeps from 25 to 75 MHz.

These two signals described above, one whose frequency is proportioned to a cosine function of time, the other proportioned to the frequency observed, are compared in a gating system. This system produces a pulse at the exact point in the receiver sweep where a fringe maximum would occur if there were an emission from the center of the sun. The difference between this point and that, where an actual fringe peak occurs, is proportioned to the displacement of the source from the center of the solar disk.

The time base, a function of the cosine of time and also the frequency separation of fringes ( $\Delta f$ ), will control a gate. The gate can make a measurement of the

frequency (tracking generator output) every 0.0004096 sec or at a rate of 2441 Hz (10 MHz/4096). However the time it takes for the sweep to change from one fringe frequency position to the next is about 0.013 sec and the increment of this change to be measured for resolution of 1.3 arc occurs in 0.007 MHz of sweep movement in frequency domain, or at a rate of 35,7142 Hz (see Table 1). The problem in making this measurement is apparent. One solution might be to increase the fundamental clock rate above 10 MHz to accomplish the desired resolution, the clock rate would have to be on the order of 7 GHz. The state-of-the-art does not provide at this time presettable accurate digital dividers at much over 100 MHz. A circuit which would solve the resolution problem was conceived by never brought to realization because of time and funding limitations.

Table 1. Fringe Measurements Limits

Angle of Source Above Horizon 1°	$\Delta f$ Separation of Fringes MHz 1.932544	$\Delta f$ for 10° MHz	t in Sec Sweep Time to Resolve 1'	1' $\Delta \Delta F$ Hz	Number of Fringes
10°	1.484	0.448	1/67K	746	33.6
20°	1.187	0.297	1/101K	495	42.1
30°	1.000	0.186	1/161K	310	50.0
40°	0.875	0.125	1/240K	208	57.1
50°	0.789	0.086	1/349K	143	63.3
60°	0.732	0.057	1/526	95	68.3
70°	0.694	0.038	1/793K	63	72.0
80°	0.673	0.021	1/1.42EM	35	74.0
90°	0.666	0.007	1/4.545	11.6	75.0

Theoretically the circuit would make the frequency measurement of the receiver's sweep in the required time with the desired accuracy by making measurements progressively in decreasing time and frequency increments as the upward moving sweep approaches each fringe position.

As shown in Figure 5, the circuit would consist of three reversible counters. One would be counting cycles of the 10 MHz designated "T" counter, another would count cycles of the tracking generator output sweeping from 25 to 75 MHz, designated "F" counter. The third counter would also count cycles of the tracking generator and would be designated " $\Delta F$ " counter.

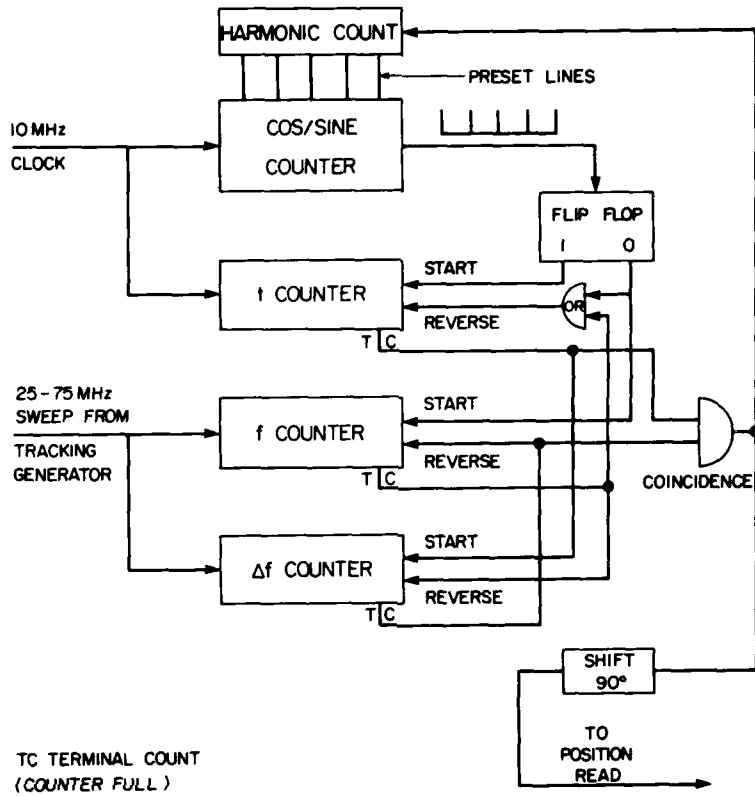

Figure 5. Fringe Position Detector

The sequence of operation of the circuit shown in Figure 5 is shown logically in Figure 6.

The cosine divider divides the 10-MHz clock frequency such that its output is a series of pulses whose period is proportioned to the cosine of time and is exactly that period in which the cycles of the sweep frequency would fill the "F" counter when a fringe position is reached. The fringe positions occur in the frequency domain at harmonics of the frequency separation between fringes. The harmonic counter is incremented when each fringe portion is detected and together with its coupling to the cosine counter maintains the pulse output period proportioned to the occurrence of fringe positions in the receiving sweeps.

When a fringe position is detected the harmonic counter is incremented. The first pulse from the cosine divider following the fringe detection starts the "T" counter. The next pulse from the cosine divider reverses the "T" counter and starts the "F" counter. When the "T" counter reaches terminal count it reverses

itself and starts the " $\Delta F$ " counter. When the "F" counter reaches terminal count it reverses itself and the " $\Delta F$ " counter is held at zero until the "T" counter reaches terminal count, then this counter starts counting. This cycle is continued until " $\Delta F$ " reaches zero at the same time as "T" counter reaches terminal count. At this point the fringe position has been detected. The process continues through the sweeps. The result is precise detection of the fringe position, and the measurement is made during a period equal to 1 cycle of the 10-MHz clock or 0.01  $\mu\text{sec}$ .

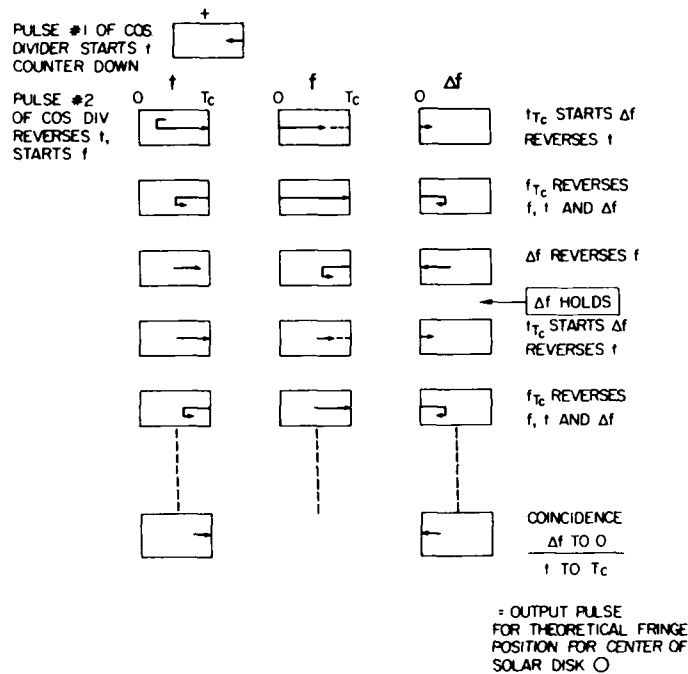

Figure 6. Logic of Fringe Position Detector

The above described method measures the frequency of the sweep and therefore is independent of any non-linearity in the sweep. Other methods may be used to detect the fringe positions; some have been tried using analog control or measurement of the receiving sweep but were not successful either, because of their limited accuracy or because of the non-linear character of most sweep receivers.

The final system output would be a digital value proportioned to the displacement of the actual solar emission from the center of the solar disk with a + or - sign to indicate which direction, east or west.

The output circuit and logic is shown in Figures 7 and 8. An up/down counter (called fringe counter) would be preset to its midpoint or 1/2 the value of its terminal (full) count. The pulse derived from the theoretical fringe position for Solar disk center + 90° would start the counter upward. A pulse derived from detection of a peak of a fringe in the receiver system output (caused by a solar emission) would reverse the fringe counter.

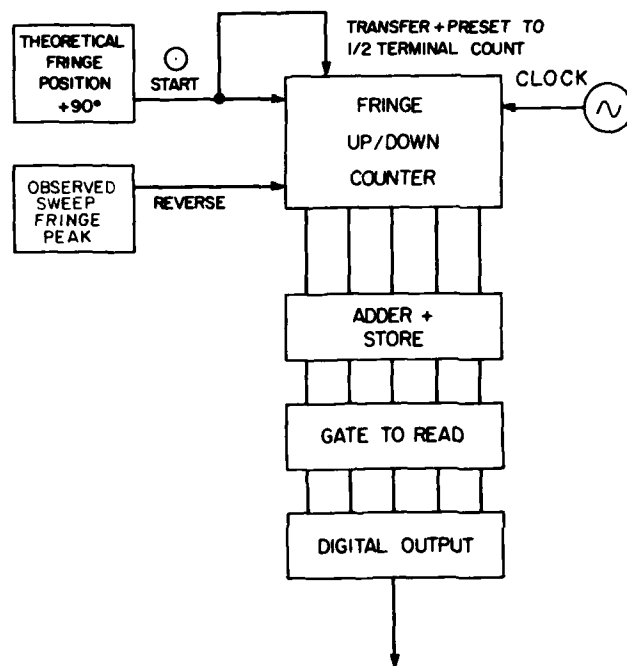

Figure 7. Fringe Read Out

The next theoretical fringe pulse would stop the count, read out the number and reset the counter for the next fringe measurement. The number in the counter at the stop point would be greater or smaller than the count at start (1/2 terminal count) by an amount proportional to the angular displacement of the real source emitting on the surface of the solar disk from the center of the disk. Its sign (greater or smaller than 1/2 full count) would indicate which direction east or west that the source was displaced from the center of the sun. This number and a series of these numbers could be totalled, then averaged. (Divide the number of measurements

to give an integrated result of the measurements.) The extent of integration could be controlled by the number of measurements used (divider of total). This would be the final output of the system.

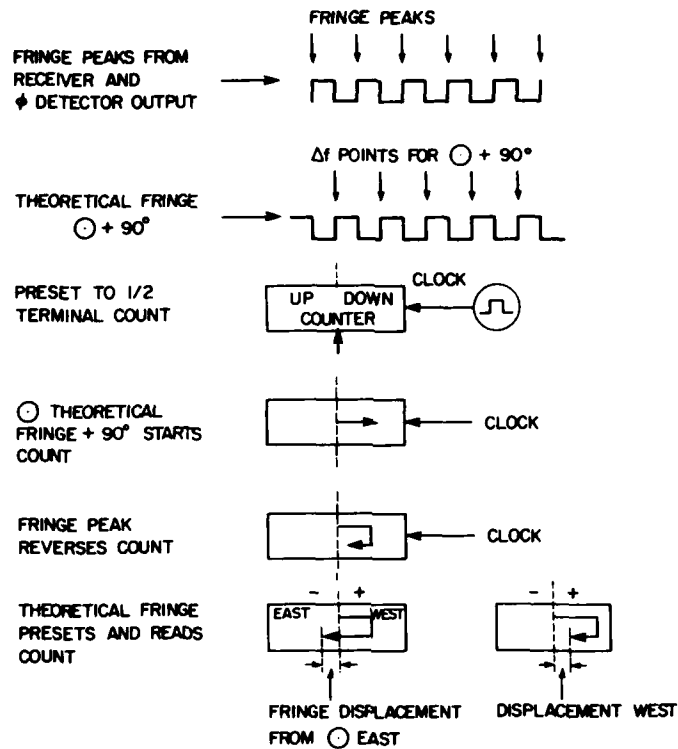

Figure 8. Resolver for Fringe Position Displacement From Center of Solar Disk Logic

There have been changes in the state-of-the-art of devices which might have application in this kind of task, perhaps offering a simpler solution. Time and funds were the main factors in preventing final realization of the concept described above.

The same general principles of the system described could be applied to a resolver of Solar emission position using the data from the fixed frequency measurements in the RSTN system. Using two antennas spaced several wavelengths (greater number of wavelengths spacing = greater resolution) a synthetically introduced



constant phase rotation of the signal from one of the antennas to a hybrid would produce fringes or modulation of the receiver output. The frequency of modulation or spacing of the fringes as they are related to the synthetically introduced phase shift would give the information needed to resolve the source position. This approach to the problem might be more fruitful than with the swept frequency data as the signal to noise ratio in the fixed frequency data is much greater.

**END**

**FILMED**

**3-86**

**DTIC**