

AD-A164 217

HOLOGRAPHIC INVESTIGATION OF SOLID PROPELLANT
COMBUSTION IN A THREE-DIMENSIONAL MOTOR(U) NAVAL
POSTGRADUATE SCHOOL MONTEREY CA S C YOON DEC 85

1/1

UNCLASSIFIED

F/G 21/8.2 NL

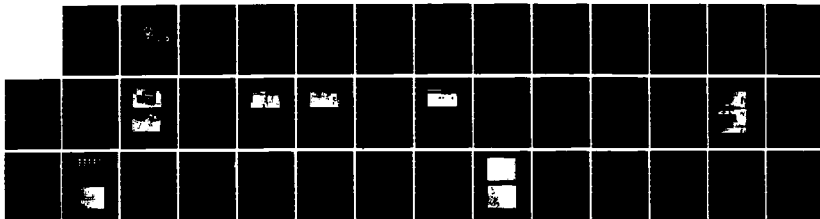

END

FIELD
IN
OFFICE

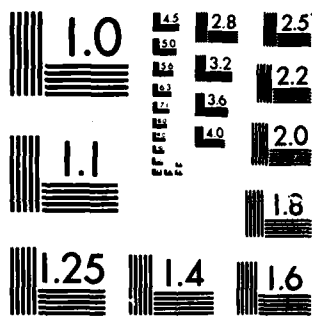

MICROCOPY RESOLUTION TEST CHART
NATIONAL BUREAU OF STANDARDS-1963-A

2

NAVAL POSTGRADUATE SCHOOL

Monterey, California

AD-A164 217



DTIC
ELECTE
FEB 14 1986
S B D

THESIS

HOLOGRAPHIC INVESTIGATION OF SOLID PROPELLANT
COMBUSTION IN A THREE-DIMENSIONAL MOTOR

by

Sang Chu Yoon

December 1985

Thesis Advisor: D. W. Netzer

DTIC FILE COPY

Approved for public release; distribution unlimited.

86 2 14 031

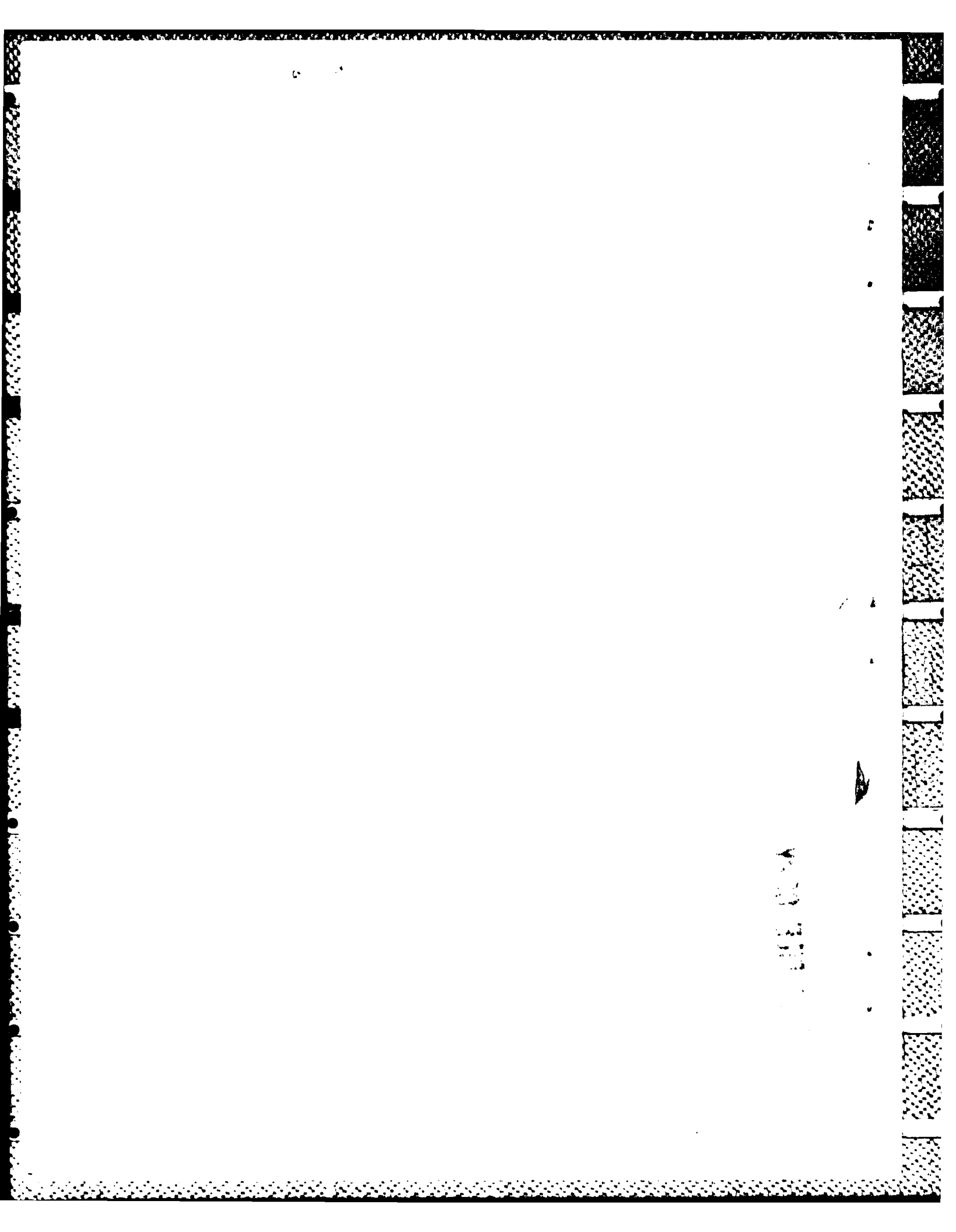

REPORT DOCUMENTATION PAGE

1a. REPORT SECURITY CLASSIFICATION UNCLASSIFIED		1b. RESTRICTIVE MARKINGS	
2a. SECURITY CLASSIFICATION AUTHORITY		3. DISTRIBUTION / AVAILABILITY OF REPORT Approved for public release; distribution unlimited.	
2b. DECLASSIFICATION / DOWNGRADING SCHEDULE		4. PERFORMING ORGANIZATION REPORT NUMBER(S)	
4. PERFORMING ORGANIZATION REPORT NUMBER(S)		5. MONITORING ORGANIZATION REPORT NUMBER(S)	
6a. NAME OF PERFORMING ORGANIZATION Naval Postgraduate School	6b. OFFICE SYMBOL (if applicable) Code 67	7a. NAME OF MONITORING ORGANIZATION Naval Postgraduate School	
6c. ADDRESS (City, State, and ZIP Code) Monterey, CA 93943-5100		7b. ADDRESS (City, State, and ZIP Code) Monterey, CA 93943-5100	
8a. NAME OF FUNDING / SPONSORING ORGANIZATION Air Force Rocket Propulsion Laboratory	8b. OFFICE SYMBOL (if applicable)	9. PROCUREMENT INSTRUMENT IDENTIFICATION NUMBER	
8c. ADDRESS (City, State, and ZIP Code) Edwards Air Force Base, CA 93523		10. SOURCE OF FUNDING NUMBERS	
		PROGRAM ELEMENT NO.	PROJECT NO. F04611-85-X-0001
		TASK NO.	WORK UNIT ACCESSION NO.
11. TITLE (Include Security Classification) HOLOGRAPHIC INVESTIGATION OF SOLID PROPELLANT COMBUSTION IN A THREE-DIMENSIONAL MOTOR (UNCLASSIFIED)			
12. PERSONAL AUTHOR(S) Sang Chu Yoon			
13a. TYPE OF REPORT Master's Thesis	13b. TIME COVERED FROM _____ TO _____	14. DATE OF REPORT (Year, Month, Day) 1985, December	15. PAGE COUNT 39
16. SUPPLEMENTARY NOTATION			
17. COSATI CODES		18. SUBJECT TERMS (Continue on reverse if necessary and identify by block number)	
FIELD	GROUP	Hologram, Transmittance Measurements, BKNO ₃ , Reconstructed Hologram, Three-Dimensional Motor	
19. ABSTRACT (Continue on reverse if necessary and identify by block number)			
<p>An investigation was conducted to determine the feasibility of obtaining holographic recordings of particulate behavior during the combustion process of solid propellant in a three-dimensional, windowed rocket motor.</p> <p>Transmittance measurements through the combustion chamber were made in order to select the appropriate neutral density filters which would yield the proper scene beam to reference beam intensity ratio. Holographic recordings were successfully made at combustion chamber pressures up to 185 psia using an HTPB-AP propellant containing 2.0 percent aluminum and 0.25 percent Fe₂O₃.</p>			
20. DISTRIBUTION / AVAILABILITY OF ABSTRACT <input checked="" type="checkbox"/> UNCLASSIFIED/UNLIMITED <input type="checkbox"/> SAME AS RPT. <input type="checkbox"/> DTIC USERS		21. ABSTRACT SECURITY CLASSIFICATION Unclassified	
22a. NAME OF RESPONSIBLE INDIVIDUAL David W. Netzer		22b. TELEPHONE (Include Area Code) (408) 646-2980	22c. OFFICE SYMBOL 67Nt

COPY 36

Approved for public release; distribution is unlimited.

Holographic Investigation of Solid Propellant
Combustion in a Three-Dimensional Motor

by

Sang Chu Yoon
Major, Korea Air Force
B.S., Korea Air Force Academy, Seoul, 1977

Submitted in partial fulfillment of the
requirements for the degree of

MASTER OF SCIENCE IN ENGINEERING SCIENCE

from the

NAVAL POSTGRADUATE SCHOOL
December 1985

Author:

Sang Chu Yoon

Sang Chu Yoon

Approved by:

D.W. Netzer

D.W. Netzer, Thesis Advisor

M.F. Platzer

M.F. Platzer, Chairman,
Department of Aeronautics

J.N. Dyer

J.N. Dyer,
Dean of Science of Engineering

ABSTRACT

An investigation was conducted to determine the feasibility of obtaining holographic recordings of particulate behavior during the combustion process of solid propellant in a three-dimensional, windowed rocket motor.

Transmittance measurements through the combustion chamber were made in order to select the appropriate neutral density filters which would yield the proper scene beam to reference beam intensity ratio. Holographic recordings were successfully made at combustion chamber pressures up to 185 psia using an HTPB-AP propellant containing 2.0 percent aluminum and 0.25 percent Fe_2O_3 .

Accession For	
NTIS GRA&I	<input checked="" type="checkbox"/>
DTIC TAB	<input type="checkbox"/>
Unannounced	<input type="checkbox"/>
Justification	
By	
Distribution/	
Availability Codes	
Dist	Avail and/or Special
A-1	



TABLE OF CONTENTS

I. INTRODUCTION 8

II. EXPERIMENTAL EQUIPMENT AND PROCEDURES 12

 A. BACKGROUND 12

 B. EQUIPMENT 12

 1. Laser 12

 2. Holocamera 13

 3. Hologram Reconstruction 14

 4. Three-Dimensional Motor 15

 C. SYSTEM CALIBRATION 17

 D. TRANSMITTANCE MEASUREMENTS 17

 E. PRE-FIRING PREPARATION 24

 F. MOTOR FIRING SEQUENCE 28

 G. HOLOGRAM PROCESSING 29

III. RESULTS AND DISCUSSION 31

IV. CONCLUSIONS AND RECOMMENDATIONS 36

LIST OF REFERENCES 37

INITIAL DISTRIBUTION LIST 38

LIST OF TABLES

I	EXHAUST NOZZLE SPECIFICATION	20
II	THE RESULTS OF TRANSMITTANCE MEASUREMENTS	25
III	SUMMARY OF TEST CONDITIONS	31

LIST OF FIGURES

2.1	Q-Switched Pulsed Ruby Recording Laser	13
2.2	Lens Assisted Holographic System Surrounding the Vertically Mounted Motor	15
2.3	Holographic Reconstruction Apparatus	16
2.4	3-D Rocket Motor Components	18
2.5	Schematic of the Motor and Propellant	19
2.6	Schematic of the Pressure Chamber and Burst Disc	21
2.7	Schematic of BKNO ₃ Igniter	22
2.8	Installation of the Rocket Motor	23
2.9	Resolution Particle Target	26
2.10	Reconstructed Hologram of 5-93 Microns Particles	26
2.11	Schematic Diagram of Transmittance Measurement Apparatus	27
3.1	Reconstructed Hologram of HTPB-AP Burned at 58 psia	33
3.2	Reconstructed Hologram of HTPB-AP Burned at 185 psia	33

ACKNOWLEDGEMENTS

I appreciate the guidance and advice by Professor D. W. Netzer in the undertaking of this project. In addition , the imagination and skill of Mr. P. J. Hickey was invaluable in transforming concepts into the hardware needed to conduct this work.

Also, my thanks to my wife and daughter for bearing with me during this period.

I. INTRODUCTION

Solid propellants were used in the earliest rockets and have been used for most guided tactical or strategic missiles because of their inherent simplicity, relatively low cost, and reliability.

Although many of the performance characteristics of solid-propellant rockets are controlled by specific properties of the solid propellant composition alone, it is actually the propellant charge or grain which must receive the most consideration. The propellant charge combines the properties of the propellant with a geometric shape to provide a means for controlling the mass generation of combustion gases. The need is to provide the maximum thrust for a minimum weight while ensuring long shelf life and safety of handling.

Powered aluminum has been used as a fuel ingredient in solid propellants because the chemical equilibrium calculations show that it provides increased specific impulse. Powered aluminum as a metal additive provides a number of practical effects [Ref. 1] that enter into its choice as a propellant ingredient.

1. Increased specific impulse and density of propellant (in appropriate formulations and motor design);
2. Only modest change in propellant burning rate in most types of propellants;
3. Suppression of combustion instability;
4. Erosion of motor components by aluminum oxide;
5. Poor combustion efficiency at low motor pressure or in small motors;
6. Reduced nozzle thrust efficiency due to thermal and velocity lag of oxide droplets;

7. Novel aspects of the exhaust plume due to large aluminum oxide content.

Slow combustion of aluminum due to formation of an oxide film on its surface and the condensed phase state of the reaction product cause a number of disadvantages [Ref. 2]. Slow burning of aluminum droplets can lead to a specific impulse loss due to poor combustion efficiency. Temperature and velocity lag in the nozzle flow also cause the two-phase flow losses which occur within the exhaust nozzle. Two-phase flow losses are often the largest impulse efficiency loss in aluminized solid propellant rocket motors. Minimization of this two-phase flow loss is required if theoretically high performing solid propellants are to produce high delivered performance. To do this, the particle sizes in the expansion process must be as small as possible while meeting the requirements for particle damping within the motor cavity. The amount of damping provided by particulate matter is a function of the size of the particles, the frequency of the oscillation and is proportional to the amount of condensate present. Pressure oscillations created in the combustion chamber can have catastrophic consequences if left unchanged. Exhaust smoke, which provides a visual warning of missile presence and maneuvering, is a by-product of aluminum combustion. The metal size and the amount of mass, as well as the other propellant ingredients, affect the amount of smoke produced.

It is highly desirable to minimize the losses through complete combustion of the metal additives prior to their exiting the combustion chamber. To do this, data are needed on the optimum required size and percentage of metal additives and on the effect of operating conditions on the behavior of particulates in the combustion chamber and the exhaust nozzle. At the present time, there are very little data available in this area. One of the diagnostic

techniques available for studying particulate behavior in solid propellant rocket motors is holography, because it provides both amplitude (as in conventional photography) and phase information about the exposed scene. This provides the capability for reconstructing the original three-dimensional image. It also enables the entire depth of field of the combustion chamber to be recorded. The flame envelopes surrounding the burning particles can be eliminated with a narrow pass filter located between the holographic plate and the scene [Ref. 3].

Single pulsed holography provides a means for effectively stopping the motion. However, it only provides information during a single instant of time. Smoke generation (i.e., small Al_2O_3 and binder products, etc.) during the combustion process presents a major obstacle to obtaining good holograms, and consists of two distinct but related problems.

The first is that a laser can only penetrate a finite amount of smoke, and the second involves the required reference beam to scene beam illumination ratio. To obtain a high-quality hologram, the illumination ratio (reference to scene) reaching the holographic plate should be between 4-10 to 1 when a test object is placed in the scene volume [Ref. 4]. If the scene beam is too bright, a neutral density filter must be placed in the scene beam, in a filter holder within the holocamera. For collimated type transmission holograms, the scene beam will be too intense. However, when diffuse scene illumination is used, as in this investigation, the reference beam intensity must be reduced.

In an earlier investigation, Lee [Ref. 5] was successful in obtaining good quality holograms using a two dimensional motor. He used borosilicate side plates as a motor casing and transmittance data as a function of propellant thickness, inhibitor thickness, and burn time. With the 2-D

motor there was an upper limit in combustion pressure (approximately 900 psia) and/or metal content (10%) where good holograms could be obtained. In addition, inhibitor char and non-uniform particle distributions in the small depth of field of the scene made data reduction from the holograms very difficult.

The object of this thesis was to develop a simple, reliable method for holographic observation of particle behavior in the port of a small 3-D solid rocket motor. The larger depth of field provided by the 3-D motor could possibly eliminate many of the problems encountered earlier with the 2-D motor, if sufficient light could be transmitted through the motor cavity to the holographic recording plate.

II. EXPERIMENTAL EQUIPMENT AND PROCEDURES

A. BACKGROUND

The use of a pulsed laser with an extremely short pulse time provides both the spatial and temporal coherence necessary to record relatively high velocity particles without blurring the image. The depth of field characteristics facilitates the imaging of the entire width of the combustion chamber. High resolution can be attained on the photographic plate by using a fine grained recording medium, high quality optics, and by maximizing the light incident on the plate. Application was made of the holographic technique developed by Lee [Ref. 5] for the recording of the behavior of particulates from burning propellant strands in a two dimensional motor.

B. EQUIPMENT

1. Laser

The laser system used was a pulsed ruby laser built by TRW, Inc., under contract to the Air Force Rocket Propulsion Laboratory. The laser operates at a wavelength of 0.6943 microns and the output beam diameter was approximately 1.25 inches. A one-joule pulse of 50 nanoseconds duration was used throughout this investigation. The system is composed of a Q-switch oscillator, ruby amplifier, beam expanding telescope, alignment autocollimator, low-power helium-neon pointing laser, coolant system and pump, capacitor bank and associated power supplies. The laser system is described in detail in Ref. 6 and is shown in Figure 2.1.

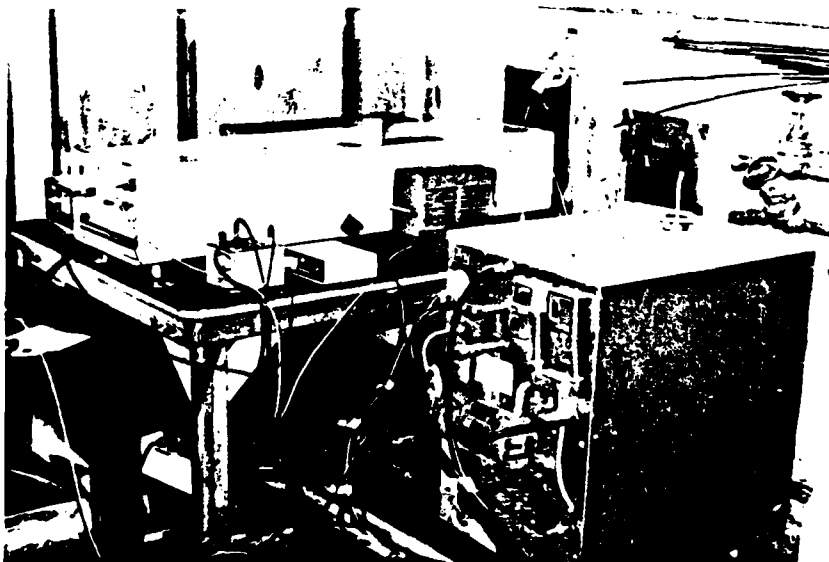
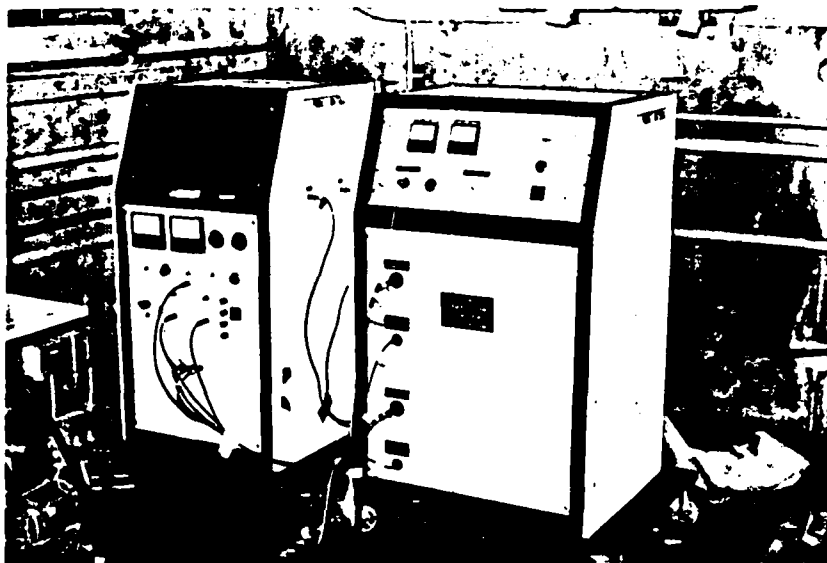

Figure 2.1 Q-Switched Pulsed Ruby Recording Laser.

2. Holocamera

The holocamera [Ref. 4], also designed by TRW, inc., was used to expose the holographic plate during the recording process and to support the plate during the reconstruction process. AGFA-GEVAERT 8E75 HD holographic plates were secured using a kinematic plate holder mounted in a removable light-tight box. The plate was positioned near the focal plane of a pair of plano convex lenses, through which passed the image to be recored. The apparatus is shown in figure 2.2.

In order to eliminate the severe "schlieren" effects caused by the burning particles, diffused scene beam illumination was employed. The required intensity ratio between the scene and reference beams could be met by placing a neutral density filter in the reference beam path inside the holocamera. A proper neutral density filter was selected by measuring the transmittance through the combustion chamber during the propellant burning.

3. Hologram Reconstruction

During image reconstruction, the developed holographic plate was reattached to the plate holder and returned to the removable holocamera box. Rear illumination was provided by a Spectra Physics model 165-11 krypton-ion CW gas laser, at a angle of approximately 60 degree with the plate normal, shown in figure 2.3. This laser has an output of one watt at a wavelength of 0.6471 microns. A variable power microscope was used to directly view the hologram. In order to minimize speckle during observation and picture taking, a rotating mylar disc was used at the reconstructed object location [Ref. 3]. The mylar disc was located at the focal point of the observation microscope. Photographs of the reconstructed scene were made using a 35mm or polaroid camera mounted to the eyepiece of the microscope.

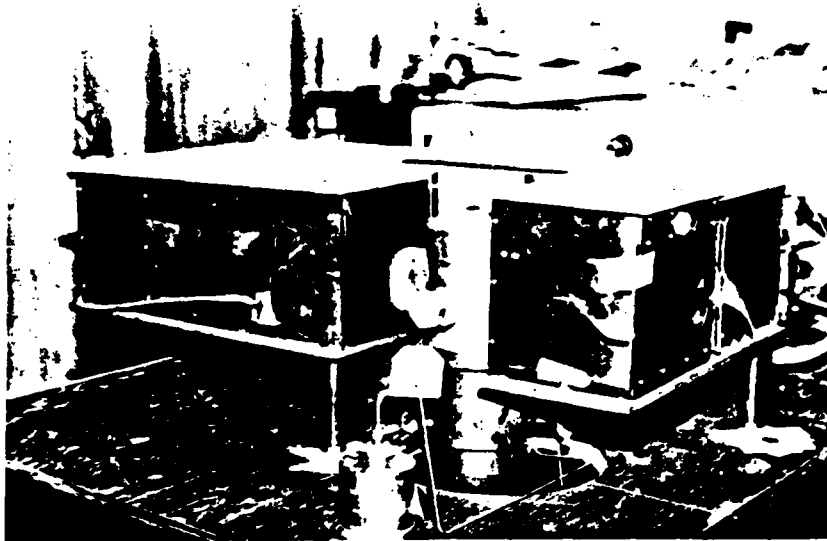

Figure 2.2 Lens Assisted Holographic System Surrounding the Vertically Mounted Motor.

4. Three-Dimensional Motor

The short 3-D motor was the same as used by Kertadidjaja [Ref. 7]. It was cylindrical, stainless steel with a copper or graphite exhaust nozzle. The motor components are shown in Figure 2.4. The chamber was two inches in diameter and two inches deep (Figure 2.5a). Four types of exhaust nozzles were used in this experiment, two copper nozzles and another two graphite nozzles. Specifications are given in Table I.

Two different sizes of circular windows were mounted in the walls of the motor, one on either side of the nozzle entrance/grain exit area (Figure 2.5a). The windows were recessed from the motor chamber. A 0.15 inches diameter window port was positioned where the laser beam entered the

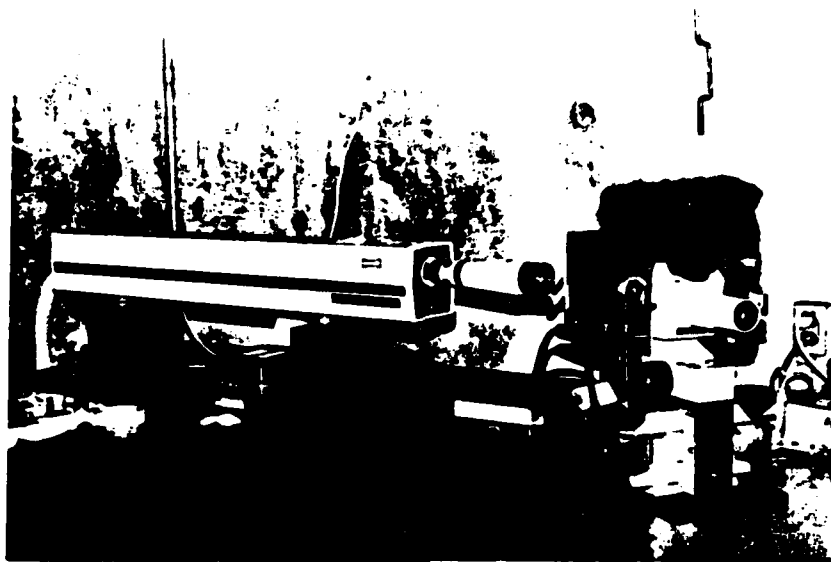

Figure 2.3 Holographic Reconstruction Apparatus.

motor. The window port through which the laser beam exited was enlarged to 0.3 inches in diameter. This increased the laser power density incident on the photographic plate, facilitating exposures through a more opaque chamber medium. To keep the windows clean, nitrogen was discharged into the recessed areas and evenly diffused through a sintered metal filter (figure 2.6). To prevent motor failure from accidental high combustion pressure, a 1000 psi burst disc was mounted in the wall of the motor (Figure 2.6).

An HTPB-AP propellant containing 2.0 percent aluminum and 0.25 percent Fe_2O_3 was selected for testing. The propellant grain was two inches in diameter and 0.5 inches in length with a web thickness of 0.775 inches. To obtain a period of reasonably steady state pressure in which to take a hologram, a cylindrically perforated grain design

was used (Figure 2.5b). Burning was allowed only on the inside surface of the propellant. To ignite the propellant, a BKNO_3 igniter (Figure 2.7) was installed in the head-end of the motor. 12 VDC was used to heat a resistance wire to fire the igniter, which in turn ignited the propellant.

A photodiode was located within the laser enclosure to sense laser firing in order to mark the precise time of laser activation on the pressure-time trace. The small 3-D rocket motor was mounted (Figure 2.8) and fired vertically (exhaust down) in the test cell. A 4-inch galvanized heat flue was mounted at the exhaust of the motor to direct exhaust products out of the test cell.

C. SYSTEM CALIBRATION

The resolution limits of the holographic system were determined by placing a Laser Electro-Optics LTD calibration standard reticle (RR-50-3.0-0.08-102) in the scene beam. One portion of this target consists of 23 spherical dots from 93 to 5 microns in diameter (Figure 2.9). A photograph of a reconstructed hologram of the reticle is shown in Figure 2.10. With very careful focusing of the rotating mylar disc, a twelve micron resolution (fourth row and fifth column) has been obtained. Currently, speckle limits the obtainable resolution. In an earlier investion, Lee [Ref. 5] found a resolution limit of approximately 9 microns using a 1951 USAF resolution bar target. That target was less realistic than the present particle target, because the actual particles in the combustion products of metalized propellants are nearly spherical in shape.

D. TRANSMITTANCE MEASUREMENTS

By measuring the transmittance through the combustion chamber during the propellant burning, a proper reference beam neutral density filter could be selected to provide the correct scene/reference beam intensity ratio. It also

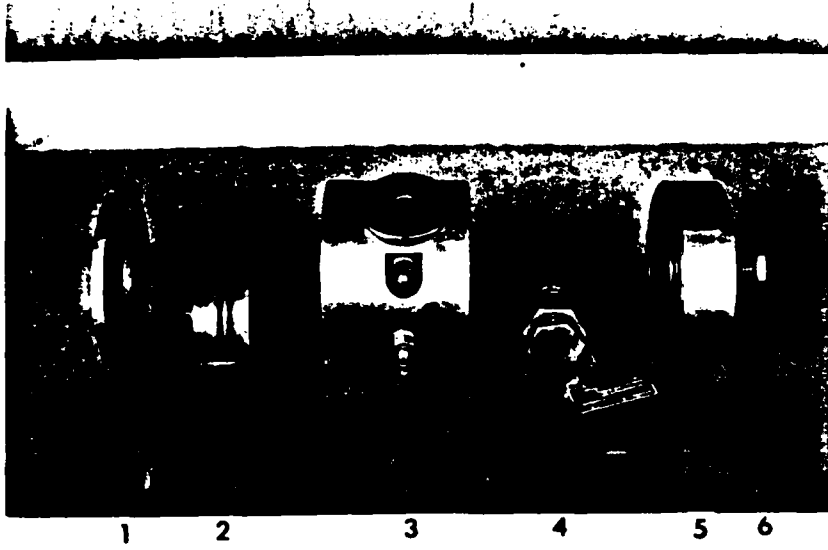

1. Nozzle Cover Plate
2. Exhaust Nozzle, Converging
3. Part of Pressure Chamber
(Glass Windows Installed)
4. Pressure Burst Disc
5. Head-End Cover
6. Igniter

Figure 2.4 3-D Rocket Motor Components.

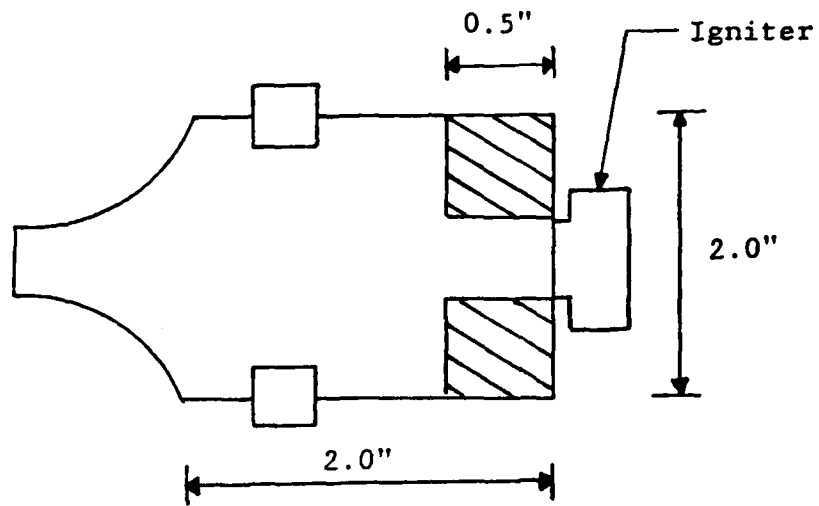

(a) Motor

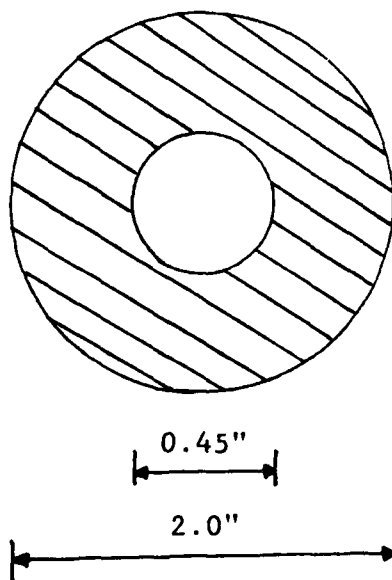

(b) Grain Design, End-View

Figure 2.5 Schematic of the Motor and Propellant.

TABLE I
EXHAUST NOZZLE SPECIFICATION

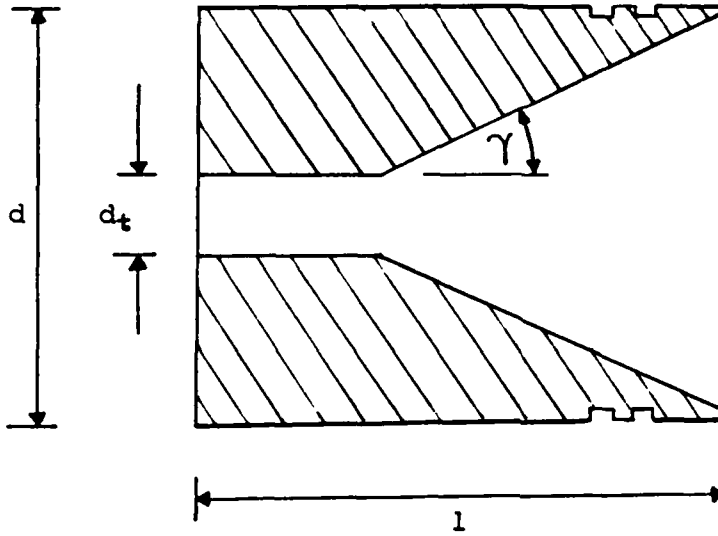

Description	Copper Nozzle (I)	Copper Nozzle (II)	Graphite Nozzle (I)	Graphite Nozzle (II)
Out Side Dia. (d , inch)	2.125	2.125	2.125	2.125
Length (l , inch)	1.25	1.25	2.15	2.15
Throat Dia. (d_t inch)	0.25	0.28	0.30	0.33
Slope Angle (γ , degree)	45	45	30	30

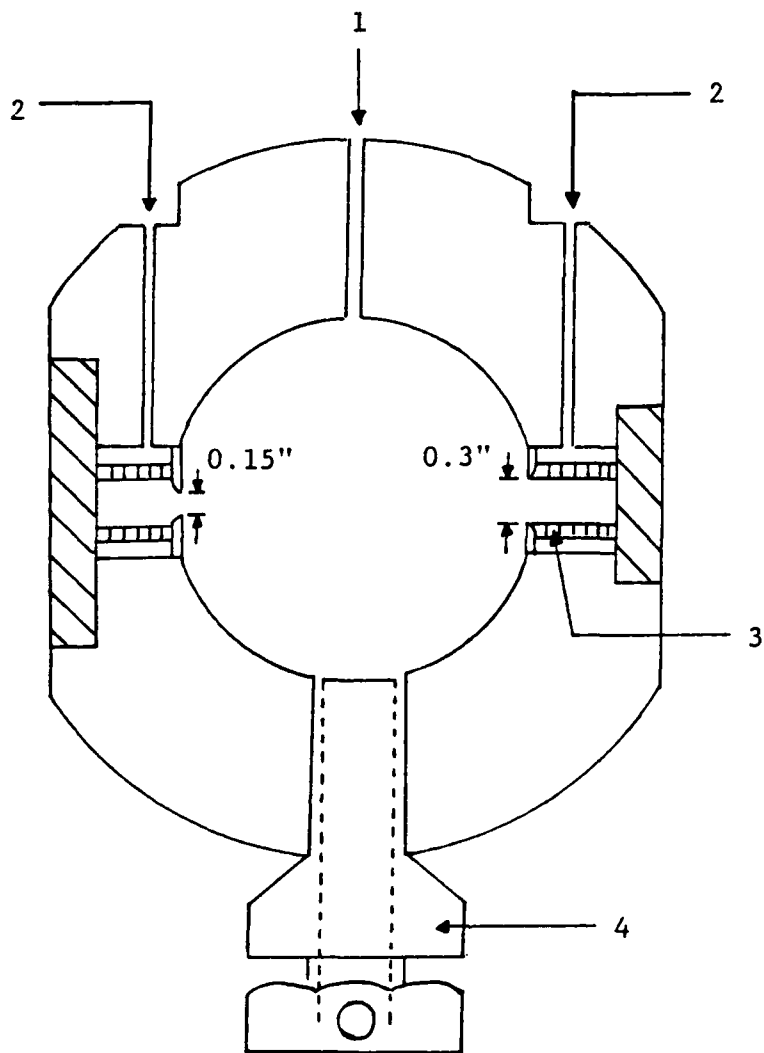

- 1. To Pressure Transducer
- 2. To Nitrogen Purge
- 3. Filter
- 4. Pressure Burst Disc

Figure 2.6 Schematic of the Pressure Chamber and Burst Disc.

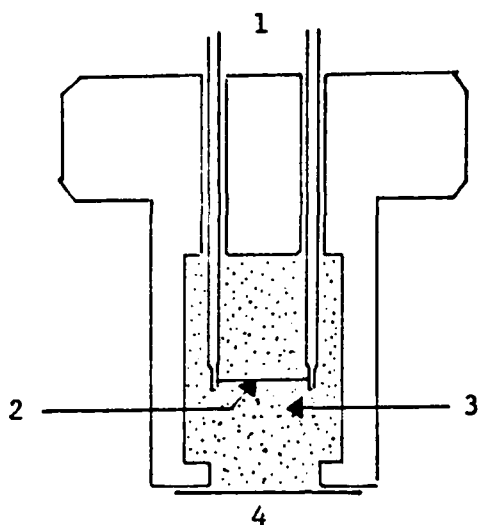

1. Copper wire
2. Nichrome wire
3. BKNO_3 Powder
4. Paper Wad

Figure 2.7 Schematic of BKNO_3 Igniter.

provided the proper time delay for firing the laser during combustion in order to obtain a good hologram. A schematic of the apparatus is presented in Figure 2.11. A Spectra-Physics model, 10-milliwatt Argon laser, 15 volt DC output photodiode and a strip-chart recorder were used to measure the transmittance. To prevent saturation of the photodiode, some neutral density filters were placed in front of it.

Propellant burning rate is a surface effect which proceeds normal to the surface and depends strongly upon combustion pressure. Combustion pressure is related to the burning surface area and nozzle throat size. For a

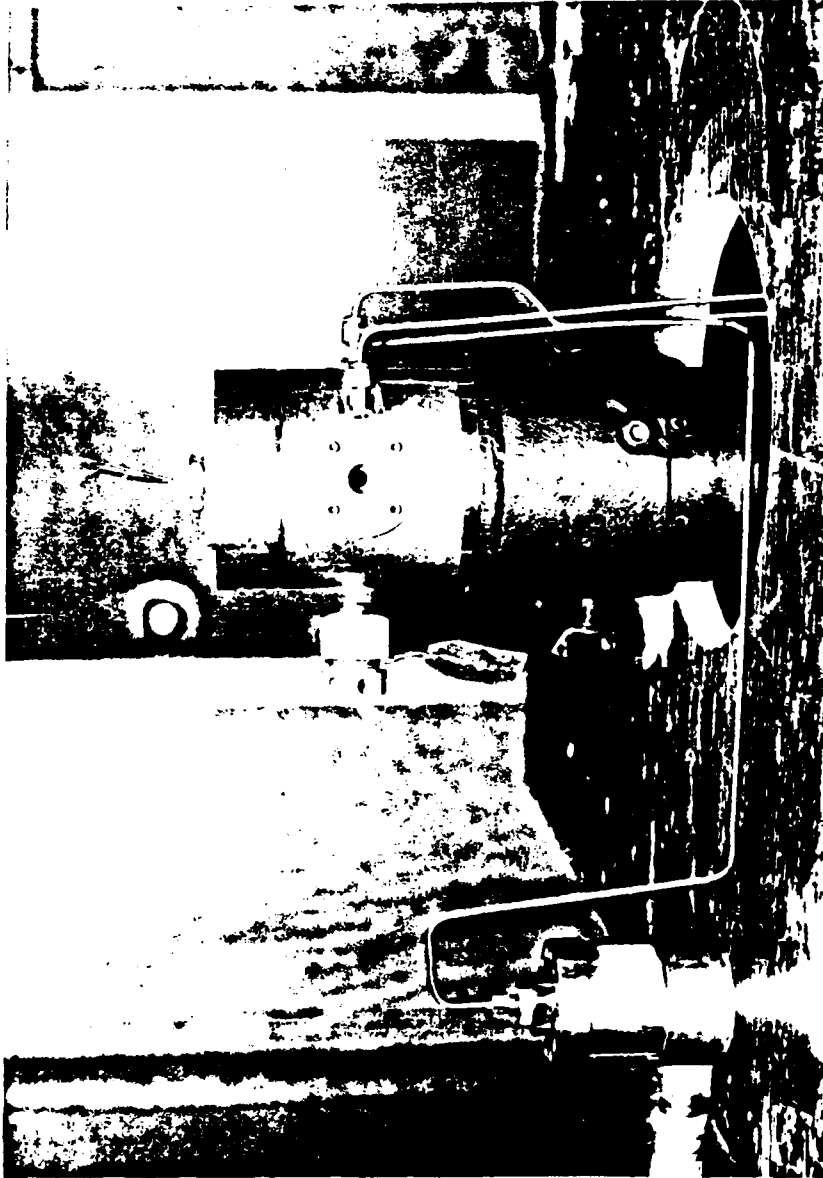

Figure 2.8 Installation of the Rocket Motor.

selected propellant, the amount of smoke depends on the combustion chamber pressure. To achieve an optimum combination of the chamber pressure, burning time and transmittance during steady state, different size nozzles and different propellant grain lengths were used in the tests. The experimental results are shown in Table II. As a result of these tests a 0.33 inches diameter nozzle and a 0.5 inches length propellant grain with both ends inhibited were selected for the initial recording of holograms. The operating pressure is quite low for these conditions, but provides a means for obtaining the initial holograms. Success at low pressure can then be followed by tests at higher pressures.

Because of the small power density of the laser scene beam that exits the motor, the reference beam intensity must be reduced. A neutral density filter of 20 percent transmittance was determined to be ideal for a high resolution hologram in the current motor configuration. This filter was inserted into the holocamera in the reference beam path.

E. PRE-FIRING PREPARATION

Holocamera preparation required ensuring that the plate-holding box and mirrors were clean. Laser and mirror alignment were checked prior to each run to ensure that the scene and reference beams were exactly overlaid on the holographic plate, and that the scene beam passed through the correct position.

The grain was cut out manually from a 0.5 or 1.0 inch thick slab of propellant using fabricated shaped cutters (Figure 2.5b), then hand rubbed to remove loose material which could cause the inhibitor to debond during firing. General Electric Hi-Temp gasket (red RTV) was carefully rubbed into the surface of the propellant to act as an inhibitor and to bond the propellant to the motor casing.

TABLE II
THE RESULTS OF TRANSMITTANCE MEASUREMENT

HTPB-AP (I) : containing 2.0% Al

HTPB-AP (II) : containing 2.0% Al, 0.25% Fe₂O₃

Type	Propellant		Nozzle Throat Diameter (inch)	Time to Reach Steady-state(sec)	Burning Time (sec)	Maximum P _c (Psia)	Transmittance During Steady-state (%)
	Length	Inhibit					
HTPB-AP (I)	1.1	one end	0.29	0.48	0.2	687	0
"	1.1	one end	0.29	0.52	0.3	710	0
HTPB-AP (II)	0.9	two ends	0.29	3.4	1.2	235	0
"	0.45	two ends	0.15	0.6	0.4	740	0
"	0.5	two ends	0.25	1.4	0.8	300	0
"	0.5	two ends	0.33	4.2	1.1	65	42

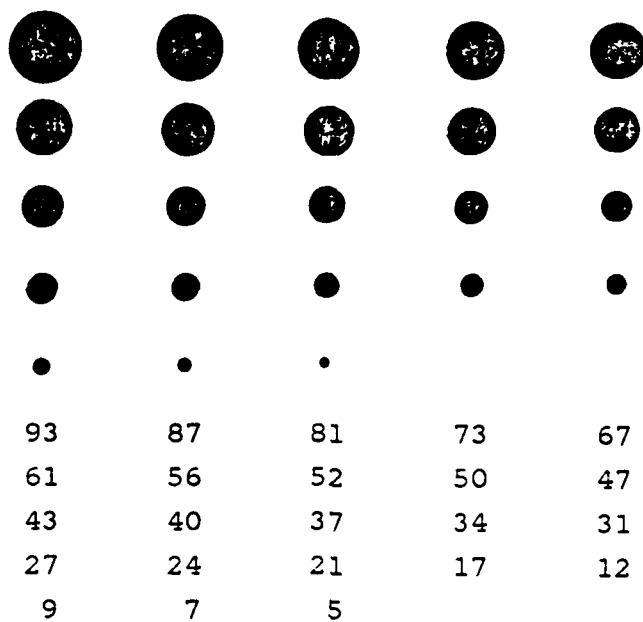

(dimension: micron)

Figure 2.9 Resolution Particle Target.

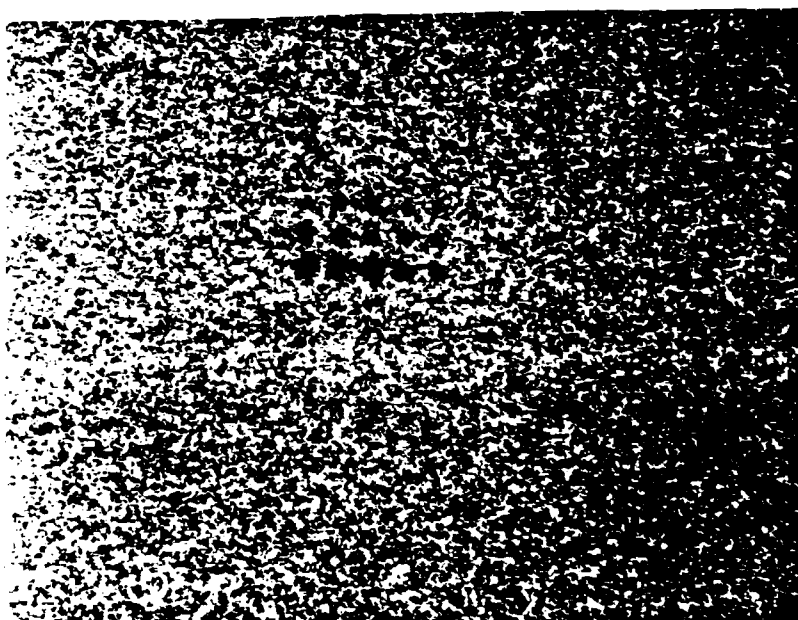

Figure 2.10 Reconstructed Hologram of 5-93 Microns Particles.

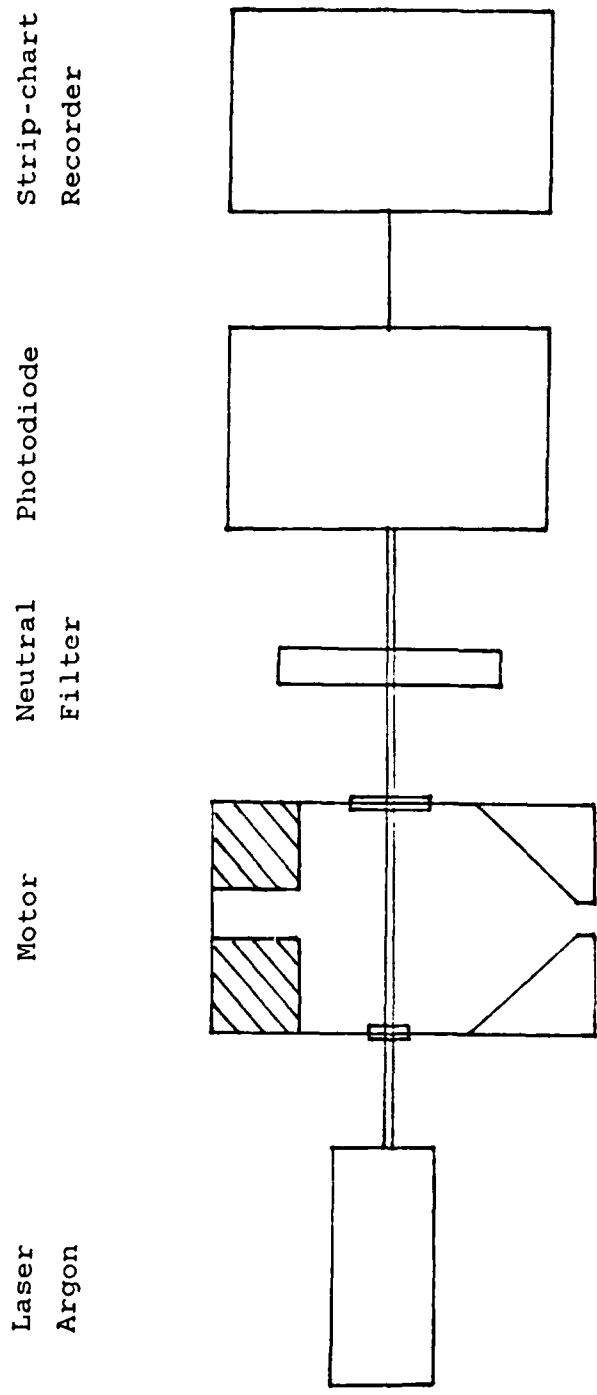

Figure 2.11 Schematic Diagram of Transmittance Measurement Apparatus.

The propellant was installed in the rocket motor and allowed to cure for twenty-four hours.

The igniters were also locally fabricated. Copper lead-in wires were soldered to the nichrome wire. The latter was placed within the igniter body and then the body was filled with BKNO_3 powder, and the end sealed with a paper wad. The two holes from which the copper wires passed were sealed with epoxy and cured for twenty-four hours.

The motor was assembled with the exhaust nozzle and nozzle cover plate, then mounted on the test stand. The holocamera was set in place and the height of motor window was aligned to the height of the laser beam by adjusting the motor stand cap. The purge and pressure lines were then connected. Window purge flow rate was adjusted before firing.

After the laser was prepared for firing, the remaining power lines and instrumentation equipment were attached, a final continuity/grounding check was made and the motor was ready for firing.

F. MOTOR FIRING SEQUENCE

The control room contained a Honeywell Visicorder which provided a time record of the entire sequence of events, including a pulse output which marked the position of the laser firing on the pressure-time trace. The time to reach steady-state pressure was not consistent from test to test with the current motor and igniter, so the time-delay, auto firing device was not helpful for taking holograms during steady state combustion. Motor and laser firings were accomplished in the manual mode. A typical firing sequence for the small rocket motor was as follows.

1. Check electrical connections.
2. Warm up the laser for approximately 5 minutes.
3. Remove the exhaust duct cover plate.

4. Set the window nitrogen purge to the correct feed pressure.
5. Open the reference beam shutter in the holocamera.
6. Check all the control panel switches to ensure proper positions.
7. Turn on warning light and secure test area.
8. Sound warning siren three times.
9. Charge the laser capacitor bank to its firing voltage, normally 20.5kv.
10. Turn on the nitrogen purge switch.
11. Start the Visicorder.
12. Initiate the fire switch.
13. Fire the laser manually during the burn.
14. Discharge the laser capacitor bank to zero.
15. Turn off nitrogen purge and fire switches.

G. HOLOGRAM PROCESSING

The exposed photographic plate was removed from the holocamera in a dark room and developed as follows

1. The plate was immersed in Kodak HRP high resolution Developer for 40 to 50 seconds and inspected periodically under a Kodak Safelight.
2. When a satisfactory image was apparent, the plate was immersed in Kodak "Stop Bath" for 30 seconds, then rinsed in fresh water
3. Kodak "Hypo-Fix" was used to set the image. Processing time was 5 minutes.
4. The plate was washed with fresh water for 10-15 minutes.
5. The plate was immersed in Kodak "Photo-flo" for one minute.
6. Air drying for 2-3 hours completed the process.

Kodak HRP was found to be a better developer than D-19 for the desired high resolution. In an attempt to improve the diffraction efficiency of the hologram (i.e., to make a

brighter image) a bleaching step was added to the processing procedure after processing in the Hypo-Fix. The hologram was bleached in a 5% solution of Cupric Bromide for 1 to 7 minutes. This process did not improve the hologram resolution when using D-19 or HRP developer, and was therefore not utilized in subsequent developing.

III. RESULTS AND DISCUSSION

A technique to obtain holographic recordings of the combustion process in a three-dimensional solid propellant rocket motor was developed during this investigation. Holograms of a burning HTPB-AP propellant were recorded at relatively low combustion pressure with a 20% or 35% transmittance neutral density filter in the reference beam path. Figures 3.1 and 3.2 are reconstructed holograms of the burning propellant and the test results are shown in Table III.

TABLE III
SUMMARY OF TEST CONDITIONS

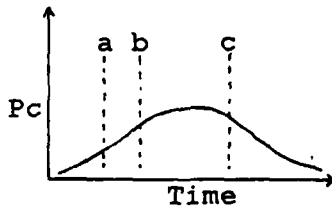

Propellant Length (inch)	Filter Transmittance (%)	Location of Hologram	Maximum Pc (psia)	Pc at which Hologram was Recorded (psia)
0.5	20	b	75	48
0.5	35	a	75	35
0.5	35	c	75	58
1.0	20	a	245	45
1.0	35	b	255	185

In the initial test which used a 20% transmittance filter in the reference beam many particles were recorded at 48 psia combustion chamber pressure, before reaching the steady state burning condition. Many of the particles were so small that they could not be clearly separated from the background speckle without further image processing. This initial hologram also showed that the scene beam intensity was stronger than that of the reference beam. Two additional tests were made using a 35% transmittance neutral density filter. The first hologram was taken at 35 psia pressure, before reaching the steady state, and the other one was taken at 58 psia, just after the steady state burning condition. A photograph of a reconstructed hologram taken at 58 psia is shown in Figure 3.1. A few larger particles were observed, but most had diameters less than 17 micrometers, similar in size to the speckle. Many of the particles can be observed with the eye when viewing through the microscope. As the scene is traversed, the particles go in and out of focus, whereas the speckle remains nearly fixed in pattern. In this hologram the scene beam intensity was still stronger than the reference beam with a 35% transmittance neutral density filter. This meant that the laser could penetrate the motor cavity with a combustion pressure higher than 58 psia. The combustion chamber pressure was therefore increased to approximately 250 psia by using a longer propellant grain (one inch), and a hologram was recorded at 185 psia, just before reaching the steady state condition. A photograph of a reconstructed hologram is shown in Figure 3.2. The particles appeared to be more numerous than at low pressure, but of approximately the same size.

A major problem in the recording of the holograms of the burning propellant using the current 3-D rocket motor and igniter was the inability to fire the laser in the manual

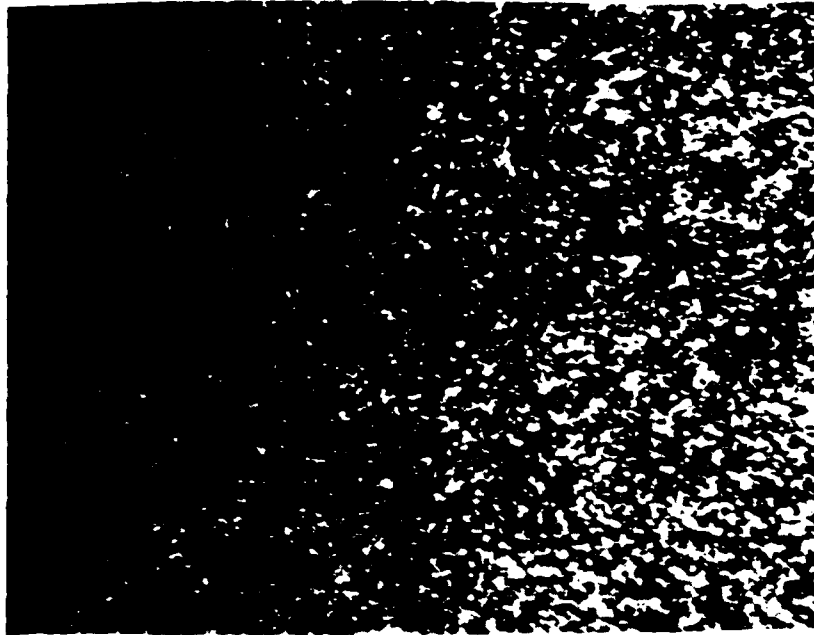

Figure 3.1 Reconstructed Hologram of HTPB-AP
Burned at 58 psia.

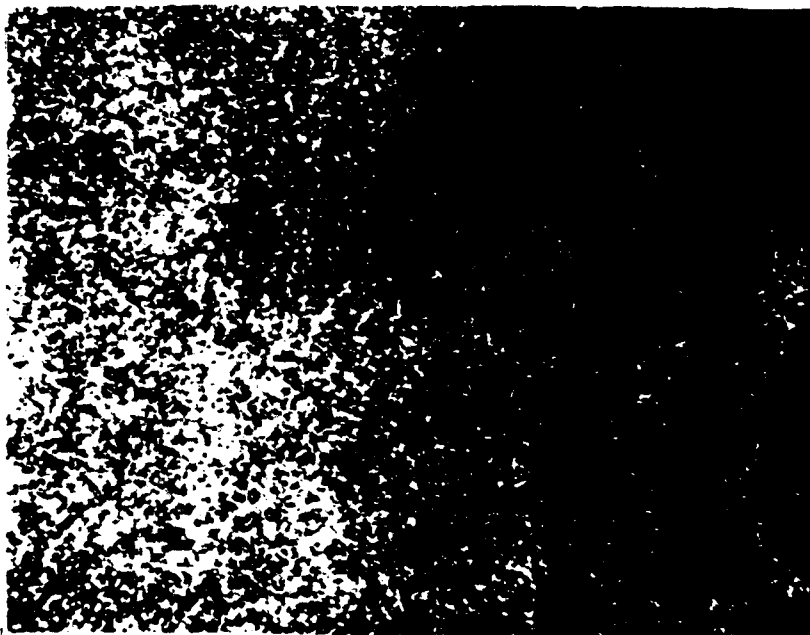

Figure 3.2 Reconstructed Hologram of HTPB-AP
Burned at 185 psia.

mode during the steady state burning condition. To closely simulate realistic steady state motor combustion conditions it is desired that the hologram be taken while the propellant is burning at a steady state pressure. The current motor ignition system did not provide consistent run- to-run results. The time delay to reach steady state was so variable that that the laser had to be fired manually during the burn. To take a hologram at the desired point during steady state burning, a time-delay auto firing device can be used. To use this device, the igniter must be modified to generate the conditions necessary for the propellant to ignite uniformly and to reach steady state pressure in a nearly constant period of time. Improvement of the igniter system reliability might include changing the nichrome wire current to heat more rapidly or positioning of the igniter to achieve a better injection pattern across the propellant surface. Another possible method is to use the existing pressure-sensing firing device instead of a time-delay auto firing. With the pressure switch activated at a preset point on the rising pressure gradient, the hologram can be taken at any subsequent desired time delay. In addition, minimizing the time to reach steady state may minimize the smoke density in the combustion chamber when the observation is made. It is the reduction of the smoke to a penetrable density that makes the holographic technique possible.

In this investigation, the opacity of the gases in the scene required that the intensity of the reference beam be reduced by means of neutral density filter. This was necessary to maintain the necessary intensity ratio of the two beams. In this initial investigation the motor pressure was limited to low values to minimize the background smoke levels. The sources of the smoke are from the burning propellant, the igniter, and the burning inhibitor. The

quantity of smoke can be reduced by decreasing the propellant charge (at the expense of chamber pressure) and by using very thin layers of inhibitor in solid contact with the motor casing and the ends of propellant grain. However, some smoke generation is inevitable. Greater laser power to provide sufficient energy density to penetrate the smoke in the motor at high pressures is probably the best solution to this problem. There are some possible ways to increase the laser beam power density of the existing system. The focal length of the diverging lens in the ruby laser can be changed to reduce the beam diameter. Only about one quarter of the present diameter is used for the scene beam. This reduction in beam size, however, may result in less coherence and resolution capability. Less opaque glass for creation of the diffuse scene beam or collimated light can also be attempted. With the present system, the illuminating laser light was diffused and the total power was reduced by approximately one seventh. A collimated beam would provide more power, but may result in many fringes on the hologram. The holocamera beam splitter can also be changed. Currently, the beam splitter surface reflects 13% of the beam into the first reference beam channel. The rest of the light (87%) passes through the wedge and is incident upon the dielectric mirrors that form the holographic scene beam for the lens-assisted transmission mode. Greater laser power to penetrate the combustion smoke might be directed to the scene beam by using a beam splitter which passes more than 87% of the beam.

The system as designed and operated will produce useable holograms at low combustion chamber pressure; however, some modifications are necessary to take better holograms at higher pressures.

IV. CONCLUSIONS AND RECOMMENDATIONS

Holograms of burning metalized solid propellant in a small, windowed motor were obtained at low combustion chamber pressures up to 185 psia with a 35% transmittance neutral density filter in the reference beam path. The upper pressure limit for the current system has not yet been determined. The laser had to be fired manually because of the unreliability of the current igniter/grain design.

For high combustion pressures, it is recommended that the laser beam power density be increased to penetrate the more opaque combustion products. Also, it is strongly recommended that a remote controlled laser firing device be used to improve the timing sequence for the hologram.

LIST OF REFERENCES

1. Advisory Group for Aerospace Research & Development, AGARD-CP-259, Combustion of Aluminum in Solid Propellant Flames, by Price, E.W., April 1979.
2. Naval Weapons Center, NWC TP 6120, Aluminum in Solid Propellant Combustion, by Kraeutle, K.J., et. al, March 1982.
3. Air Force Rocket Propulsion Laboratory, AFRPL-TR-84-014, An Investigation of Experimental Techniques for Obtaining Particulate Behavior in Metalized Solid Propellant Combustion, by Netzer, D.W., et. al., February 1984.
4. Air Force Rocket Propellant Laboratory, AFRPL-TM-78 12, Operation Manual for the Lens-Assisted Multipurpose Holocamera With Reflected Light Option, by Wuerker, R.F. and Briones, R.A., July 1978.
5. Lee, Y.S. Holographic Investigation of Solid Propellant Combustion in a Two-Dimensional Motor, M.S. Thesis, Naval Postgraduate School, September 1984.
6. Air Force Rocket Propellant Laboratory, AFRPL-TM-78-11, Investigation Manual for the improved Ruby Laser Holographic Illuminator by Briones, R.A. and Wuerker, R.F., July 1978.
7. Kertadidjaja, A., Particle Sizing in a Solid Rocket Motor Using the Measurement of Scattered Light, M.S. Thesis, Naval Postgraduate School, March 1985.

INITIAL DISTRIBUTION LIST

	No.	Copies
1. Library, Code 0142 Naval Postgraduate School Monterey, California 93943	2	
2. Defense Technical Information Center Cameron Station Alexandria, Virginia 22304-6145	2	
3. Chairman, Code 67 Department of Aeronautics Naval Postgraduate School Monterey, California 93943	1	
4. Professor D.W. Netzer, Code 67Nt Department of Aeronautics Naval Postgraduate School Monterey, California 93943	2	
5. Chief of Staff Republic Of Korea Air Force Dae Bang Dong, Young Deung Po Gu Republic Of Korea Air Force Headquarter Seoul Korea	2	
6. Sang Chu Yoon U-dong 404 Ho Minyoung Apt. 301-106 Dong Bu I Chon Dong Seoul Korea	3	
7. Young Man Lee SMC #2748 Naval Postgraduate School Monterey, California 93943	2	

END

FILMED

386

DTIC