

AD-A162 516

INSTALLATION RESTORATION GENERAL ENVIRONMENTAL
TECHNOLOGY DEVELOPMENT TAS. (U) WESTON (ROY F) INC WEST
CHESTER PA L J BOVE ET AL JUN 85 AMXTH-TE-TR-85010
DAAK11-82-C-0017 F/G 13/2

1/2

UNCLASSIFIED

NL

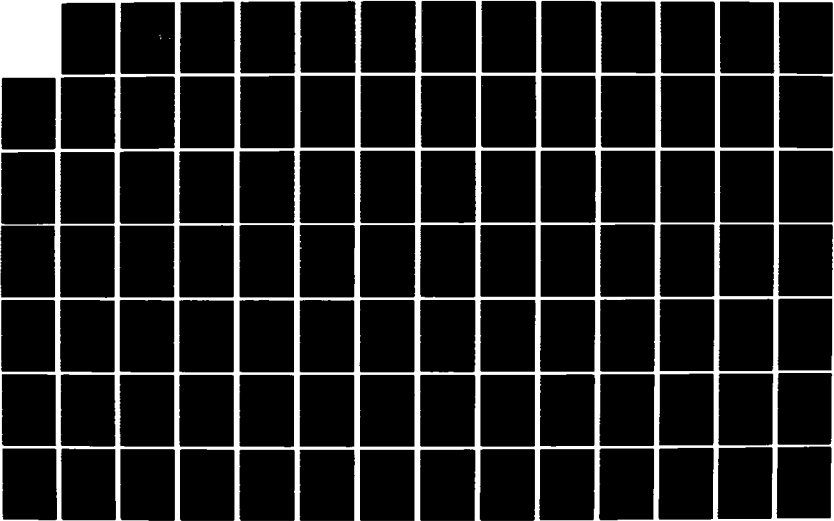

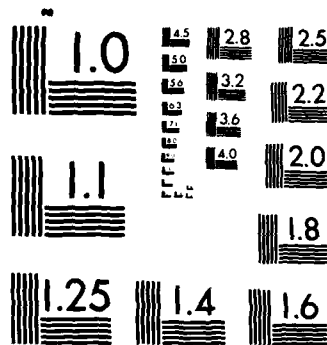

MICROCOPY RESOLUTION TEST CHART
NATIONAL BUREAU OF STANDARDS-1963-A

12

Contract No. DAAK1182-C-0017
Task Order 6

Report No. AMXTH-TE-TR-85010

INSTALLATION RESTORATION GENERAL ENVIRONMENTAL
TECHNOLOGY DEVELOPMENT

Task 6. Materials Handling of Explosive Contaminated
Soil and Sediment

AD-A162 516

FINAL REPORT

Lawrence J. Bove
M. Ramanathan, Ph.D., P.E.
John W. Noland, P.E.
Peter J. Marks

DTIC
ELECTR
DEC 12 1985
S D

ROY F. WESTON, INC.
WEST CHESTER, PENNSYLVANIA 19380

June 1985

DISTRIBUTION UNLIMITED: APPROVED FOR PUBLIC RELEASE

PREPARED FOR:

U.S. ARMY TOXIC AND HAZARDOUS MATERIALS AGENCY
ABERDEEN PROVING GROUND (EDGEWOOD AREA), MARYLAND 21010-5401

5449A

DTIC FILE COPY

85 12 12 077

REPORT DOCUMENTATION PAGE		READ INSTRUCTIONS BEFORE COMPLETING FORM
1. REPORT NUMBER AMXTH-TE-TR-85010	2. GOVT ACCESSION NO. AD-A162516	3. RECIPIENT'S CATALOG NUMBER
4. TITLE (and Subtitle) Materials Handling of Explosive Contaminated Soils and Sediments	5. TYPE OF REPORT & PERIOD COVERED Final Report Jan. 1984 - June 1985	
	6. PERFORMING ORG. REPORT NUMBER	
7. AUTHOR(s) Lawrence J. Bove, M. Ramanathan, John W. Noland, Peter J. Marks	8. CONTRACT OR GRANT NUMBER(s) DAAK11-82-C-0017	
9. PERFORMING ORGANIZATION NAME AND ADDRESS Roy F. Weston, Inc. Weston Way West Chester, PA 19380	10. PROGRAM ELEMENT, PROJECT, TASK AREA & WORK UNIT NUMBERS	
11. CONTROLLING OFFICE NAME AND ADDRESS U.S. Army Toxic & Hazardous Materials Agency Aberdeen Proving Ground (Edgewood Area), MD 21010 Donna Koltuniak, Project Officer	12. REPORT DATE June 1985	
	13. NUMBER OF PAGES	
14. MONITORING AGENCY NAME & ADDRESS (if different from Controlling Office)	15. SECURITY CLASS. (of this report) UNCLASSIFIED	
	15a. DECLASSIFICATION/DOWNGRADING SCHEDULE	
16. DISTRIBUTION STATEMENT (of this Report) Approved for Public Release, Distribution Unlimited		
17. DISTRIBUTION STATEMENT (of the abstract entered in Block 20, if different from Report)		
18. SUPPLEMENTARY NOTES		
19. KEY WORDS (Continue on reverse side if necessary and identify by block number) Soil Contamination Solids Handling Site Assessment Explosives Sensitivity Testing Materials Handling Geophysical Analysis Excavation Site Categorization		
20. ABSTRACT (Continue on reverse side if necessary and identify by block number) Past practices at explosives manufacturing and handling facilities have resulted in contaminated soils and lagoon sediments. Treatment and handling procedures for these soils and sediments will result in numerous safety concerns due to the potentially reactive nature of these materials.		

→ This report discusses the development of typical materials handling processes from removal of soils/sediments from a particular site to feed into a treatment or disposal process. As part of the study, sensitivity testing was reviewed to enable recommendations for complete analysis of contaminated soils.

Materials handling techniques, including state-of-the-art explosives handling and other adaptable solids handling techniques, were compiled into four application categories: excavation/removal, transport, conditioning/storage, and feed. The discussion of these materials handling technologies includes a process description, potential sources of ignition inherent to the equipment operation, applicability of differing site characteristics, and possible design and operating modifications to reduce the potential for ignition. *As part of the handling*

A materials handling protocol for contaminated soils and sediments was developed using a two step procedure. Initially each site will undergo a detailed site categorization which will include site assessment, field sampling with chemical analysis, and a sensitivity testing program. Data developed in the site categorization will be applied to a handling technique selection decision matrix which will aid in determining special handling requirements.

UNCLASSIFIED

The views, opinions, and/or findings contained in this report are those of the authors and should not be construed as an official Department of the Army position, policy, or decision unless so designated by other documentation.

Accession For	
NTIS CRA&I	<input checked="" type="checkbox"/>
DTIC TAB	<input type="checkbox"/>
Unannounced	<input type="checkbox"/>
Justification	<input type="checkbox"/>
By	
Distribution/	
Availability Codes	
Dist	Avail and/or Special
A-1	



CONTENTS

Paragraph		<u>Page</u>
1	EXECUTIVE SUMMARY	1
1.1	General	1
1.2	Objectives	1
1.3	Problem definition	1
1.4	Materials handling techniques	1
1.5	Development of materials handling protocol	5
1.6	Field demonstration tests	8
1.7	Use of Decision Matrix	8
2	BACKGROUND INFORMATION	12
2.1	General	12
2.2	Objectives	12
3	PROBLEM DEFINITION	14
3.1	General	14
3.2	Materials handling scenario	14
3.3	Sources of ignition	14
3.4	Conditions conducive to ignition	16
3.5	Site-specific conditions	16
3.5.1	Moisture content	16
3.5.2	Explosives concentration	17
3.5.3	Location of the treatment facility...	17
3.6	Materials handling performance criteria	18
4	SENSITIVITY TESTING	20
4.1	Reasons for sensitivity testing	20
4.2	Sensitivity test methods	20
4.3	Development of sensitivity test protocol	20
4.4	Recommended sensitivity test program	24
5	DEVELOPMENT OF MATERIALS HANDLING PROTOCOL	27
5.1	General	27
5.2	Site categorization	27
5.2.1	Initial site assessment	27
5.2.2	Field sampling and chemical analysis	31
5.2.3	Sensitivity testing	33
5.3	Selection of equipment	33
5.3.1	Basis for equipment selection	36
5.3.2	Sensitivity zones	36
5.3.3	Determination of materials handling scenario	37

CONTENTS

		<u>Page</u>
Paragraph 6	CONCLUSIONS AND RECOMMENDATIONS	42
6.1	Conclusions	42
6.2	Recommendations	43
7	REFERENCES	45
	APPENDIX A - MATERIALS HANDLING TECHNIQUES	A-1
	APPENDIX B - SENSITIVITY TEST METHODS	B-1
	APPENDIX C - USATHAMA METHOD 8H: EXPLOSIVES IN SOIL BY HPLC	C-1

FIGURES

		<u>Page</u>
FIGURE 1.	Work plan	2
2.	Typical materials handling scenario ...	3
3.	Materials handling protocol	6
4.	Sensitivity testing protocol	7
5.	Decision matrix for selecting materials handling techniques	9
6.	Typical materials handling scenario for explosives contaminated soils/ sediments	15
7.	Materials handling protocol	28
8.	Sensitivity testing protocol	35
9.	Decision matrix for selecting materials handling techniques	38
10.	Typical hazard analysis	41

TABLES

		<u>Page</u>
TABLE 1.	Technique summary	5
2.	Potential forces and conditions for ignition present during operation of materials handling techniques	10
3.	Performance criteria for materials handling equipment	19
4.	Anticipated sources and conditions of ignition related to materials handling category	21
5.	Sensitivity test summary	22
6.	Criteria for selecting necessary sensitivity test	25
7.	Sensitivity test methods related to anticipated sources or conditions of ignition	26
8.	Summary of items contained in the USATHAMA data package	30
9.	Summary of currently available geo- physical test procedures applicable at explosives contaminated sites	32
10.	Sensitivity test protocol	34
11.	Identified sources/conditions for ignition present during operation of the listed materials handling equipment	39

1. EXECUTIVE SUMMARY

1.1 General. Past operations at U.S. Army installations involved the manufacture, assembly, and handling of explosives and explosive devices. These operations, and disposal of carrier waters from these facilities, have resulted in explosives contaminated soils and sediments (hereinafter referred to as "materials") which may contain concentrations of up to 50 percent explosives (dry weight basis). If left untreated, the materials present a potential source of soil and groundwater contamination.

1.2 Objectives. Based on the above situation, the objectives of this study were to:

- (a) Provide problem classification,
- (b) Establish materials handling performance criteria,
- (c) Develop test scenario to determine which materials require special handling,
- (d) Identify state-of-the-art explosives handling techniques that may be adaptable to handling explosives contaminated materials,
- (e) Develop a typical explosives contaminated site work plan to be employed by the designated contractor,
- (f) Develop a materials handling protocol decision matrix to be employed by the designated contractor in conjunction with USATHAMA and the Army safety community,
- (g) Identify selected phases of a materials handling scenario that require limited laboratory and/or field testing before implementation, and
- (h) Prepare test plan(s) for those phases of a materials handling scenario selected by USATHAMA from item (g).

1.3 Problem definition. Figure 1 illustrates the work plan employed for developing materials handling protocol for explosives contaminated materials. For this study, materials handling included: excavation or removal of contaminated materials from contaminated areas; transporting, conveying, or other forms of material movement from point of origin to disposal or treatment destination; and feeding or conveying materials into a treatment or disposal process. Figure 2 illustrates the unit process involved for a typical materials handling scenario.

1.4 Materials handling techniques. Upon completion of a review of available information and visits to explosives manufacturing facilities, a comprehensive list was compiled of state-of-the-art explosives handling and other adaptable solids

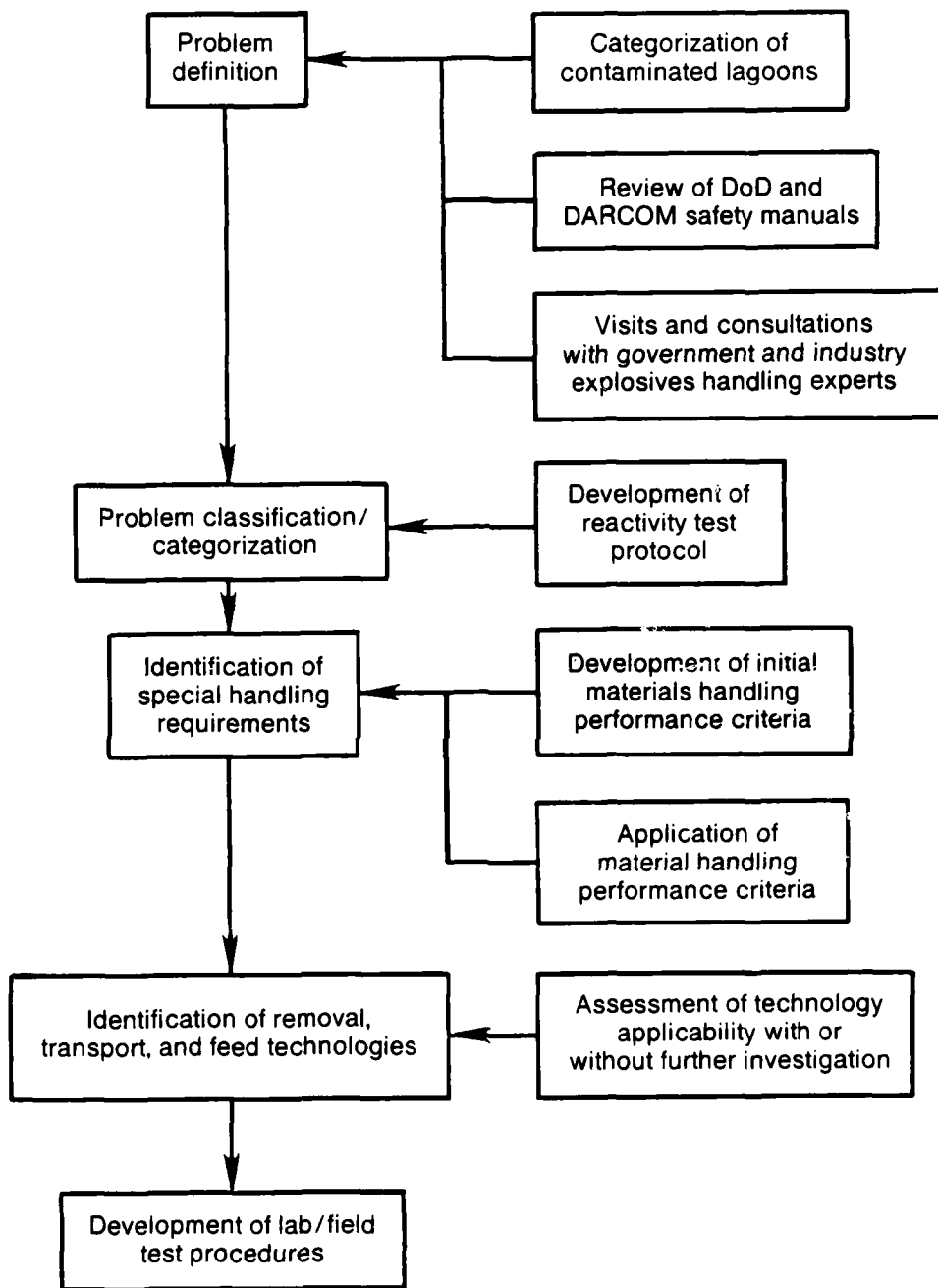

Figure 1. Work plan.

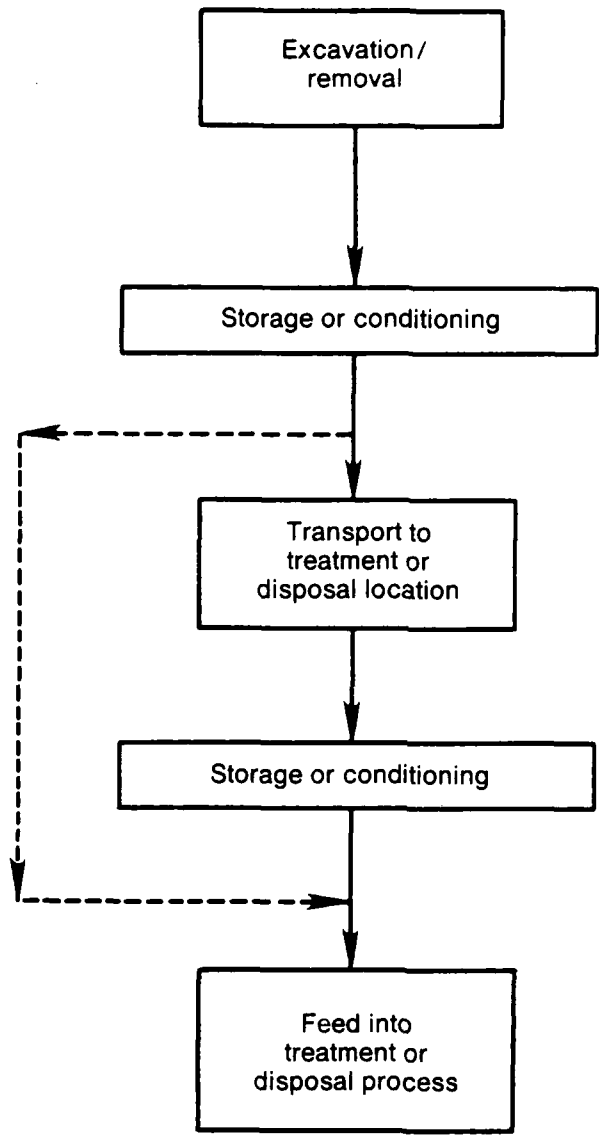

Figure 2. Typical materials handling scenario.

handling techniques. These techniques fell into four broad application categories: excavation/removal, transport, conditioning/storage, and feed systems. The techniques and respective application categorizations are summarized in Table 1.

1.5 Development of materials handling protocol. Materials handling protocol for explosives contaminated sites will be developed using the procedure illustrated in Figure 3. Initially each site will undergo a detailed site categorization which will include:

- (a) Site assessment,
- (b) Field sampling and chemical analysis, and
- (c) Sensitivity test program.

The site assessment will include existing data review followed by a geophysical survey to determine the location of any unexploded ordnance and to identify pockets of pure or concentrated explosives. (The methods for geophysical testing are listed in Subsection 5.2, Table 9.)

Based on information acquired, a sampling grid will be developed. Surface and core samples will be taken and analyzed for concentration of explosives so that vertical and horizontal explosives concentration profiles can be developed.

The next step in the site categorization, sensitivity testing, was developed based on identified sources of ignition which might occur during operations of material handling equipment and the available sensitivity test procedures identified during the primary phases of this task order. The following sensitivity tests were selected for application in this program:

- (a) Impact test (Bureau of Mines).
- (b) Friction test.
- (c) Electrostatic test.
- (d) U.S. gap test.
- (e) Thermal stability test.

Although performance of the sensitivity test program on all soils would provide a complete site characterization, it will result in time conflicts while testing is being performed. WESTON has proposed a testing program that will reduce the number of soils undergoing sensitivity testing, but will provide the information necessary to characterize a site in terms of sensitivity. The logic diagram for this program is illustrated in Figure 4. The program focuses on samples with the highest concentrations of explosives based on the chemical analyses conducted during item (b) of the site characterization.

TABLE 1. TECHNIQUE SUMMARY

Materials handling technique	Excavation/ removal	Transport ¹	Conditioning or storage	Treatment or disposal feed ²
Clamshell	X			
Dragline	X			
Front-end loader	X			
Backhoe	X			
Dredging	X			X
Vacuum removal transport	X			X
Railroad car transport		X		
Vehicular transport		X		
Mechanical screening			X	
Containerization			X	
Mechanical dewatering: centrifuge			X	
Delumper			X	
Wet grinding			X	
Storage vessel			X	
Magazine storage			X	
Slurry pump		X		X
Hydrosluicing				X
Belt conveyors				X
Screw conveyors				X
Bucket conveyors				X
Vibratory conveyors				X
Pneumatic conveyor				X
Rotary feed system				X
Manual feed				X
Ram feed system				X
Gravity				X

¹Generally includes transport over DOT-regulated highways and railways.

²May include short-distance transport (within site boundaries).

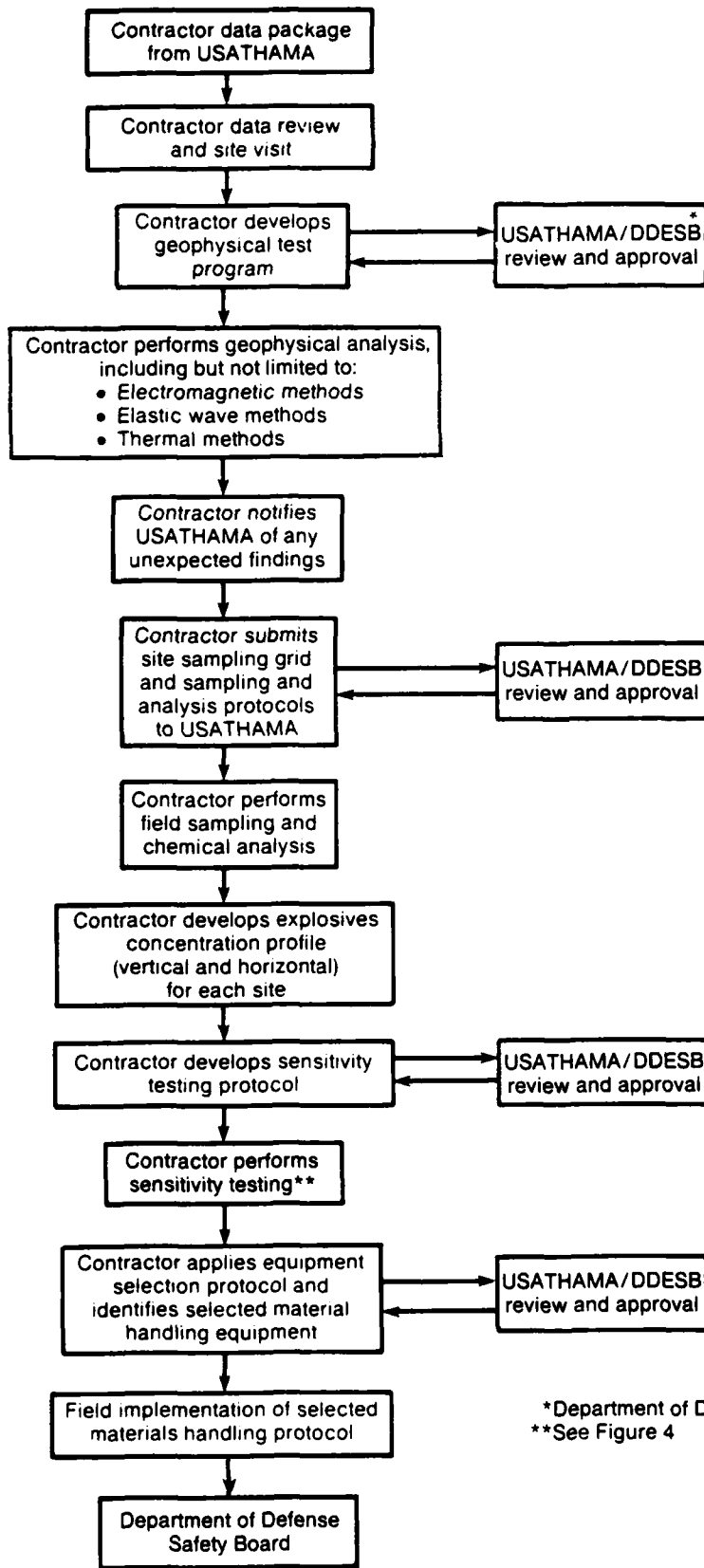

*Department of Defense Explosives Safety Board
 **See Figure 4

Figure 3. Materials handling protocol.

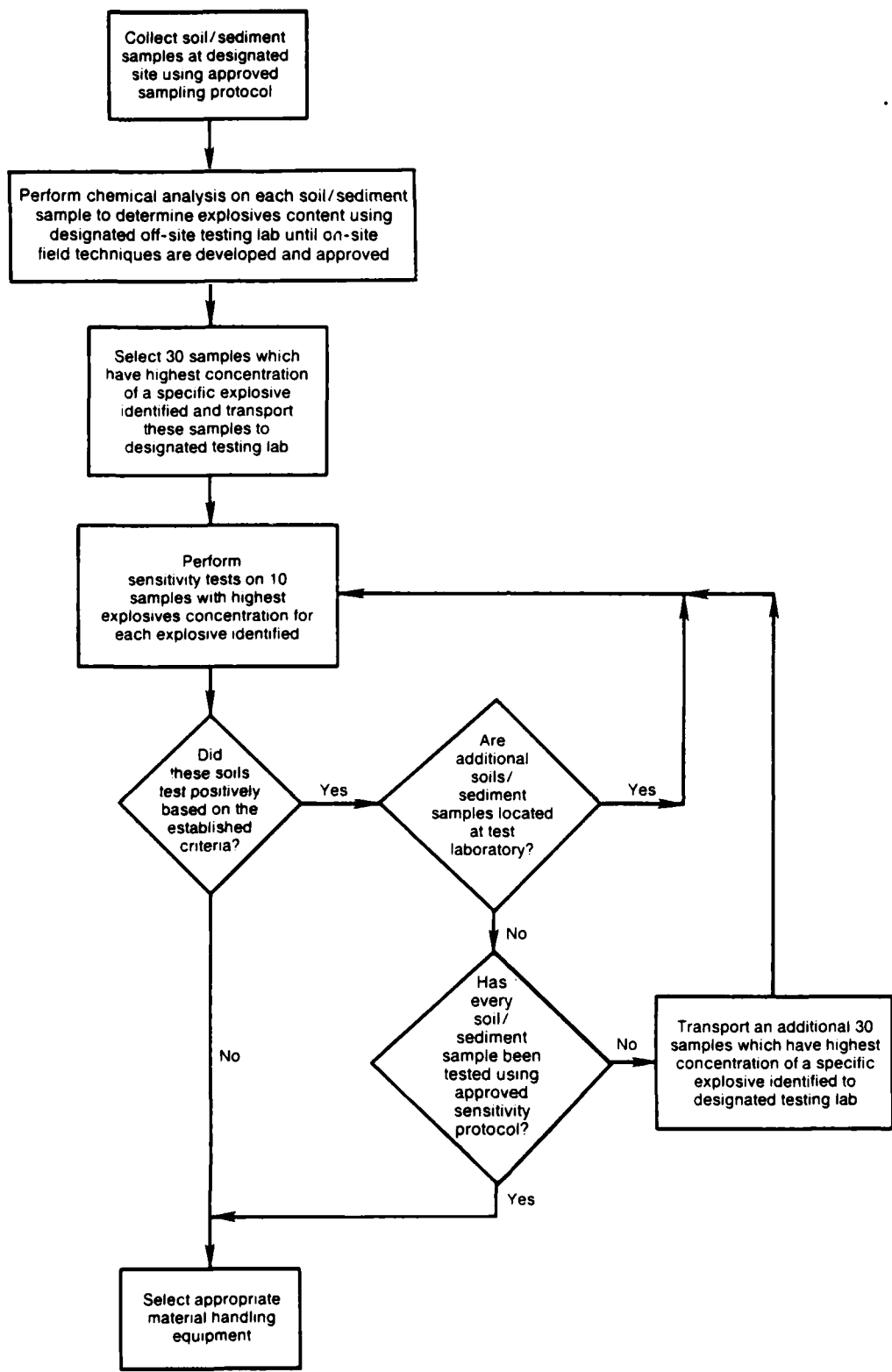

Figure 4. Sensitivity testing protocol.

1.6 Field demonstration tests. An objective of this study was to identify selected phases of a materials handling scenario that would require limited laboratory and/or field testing before implementation. As information was acquired during this study, it became apparent that the following conditions would dictate the selection of materials handling equipment:

- (a) Sensitivity of the material based on sensitivity testing protocol.
- (b) Physical characteristics of site:
 - Moisture content
 - Accessibility
 - Topography
- (c) Location of treatment facility:
 - On-site local
 - On-site remote
 - Off-site
- (d) Treatment or disposal process requirements and constraints:
 - Feed requirements
 - Acceptable moisture level
- (e) Regulatory constraints:
 - Federal
 - State
 - Local

Each site will have unique properties that will affect the selection of materials handling techniques. Therefore, testing of single materials handling scenario would yield results with limited application to the entire materials handling program.

Ideally, a field testing program that utilizes an actual contaminated site and the decision matrix illustrated in Figure 5 would be a true test of the protocols developed in this study. A test of this type would identify the controlling costs, the controlling time procedures, and the operability of equipment at a potential sensitive site. However, the test would only verify the applicability of a specific material handling program to a specific site.

1.7 Use of decision matrix. Data compiled during site categorization procedures will be applied in the decision matrix pictured in Figure 5 and used with Table 2. The matrix enables the user to perform the following:

- (a) Select applicable standard materials handling techniques. The contractor will review the materials handling techniques listed in Table 2. Based on knowledge of site-specific conditions (i.e.,

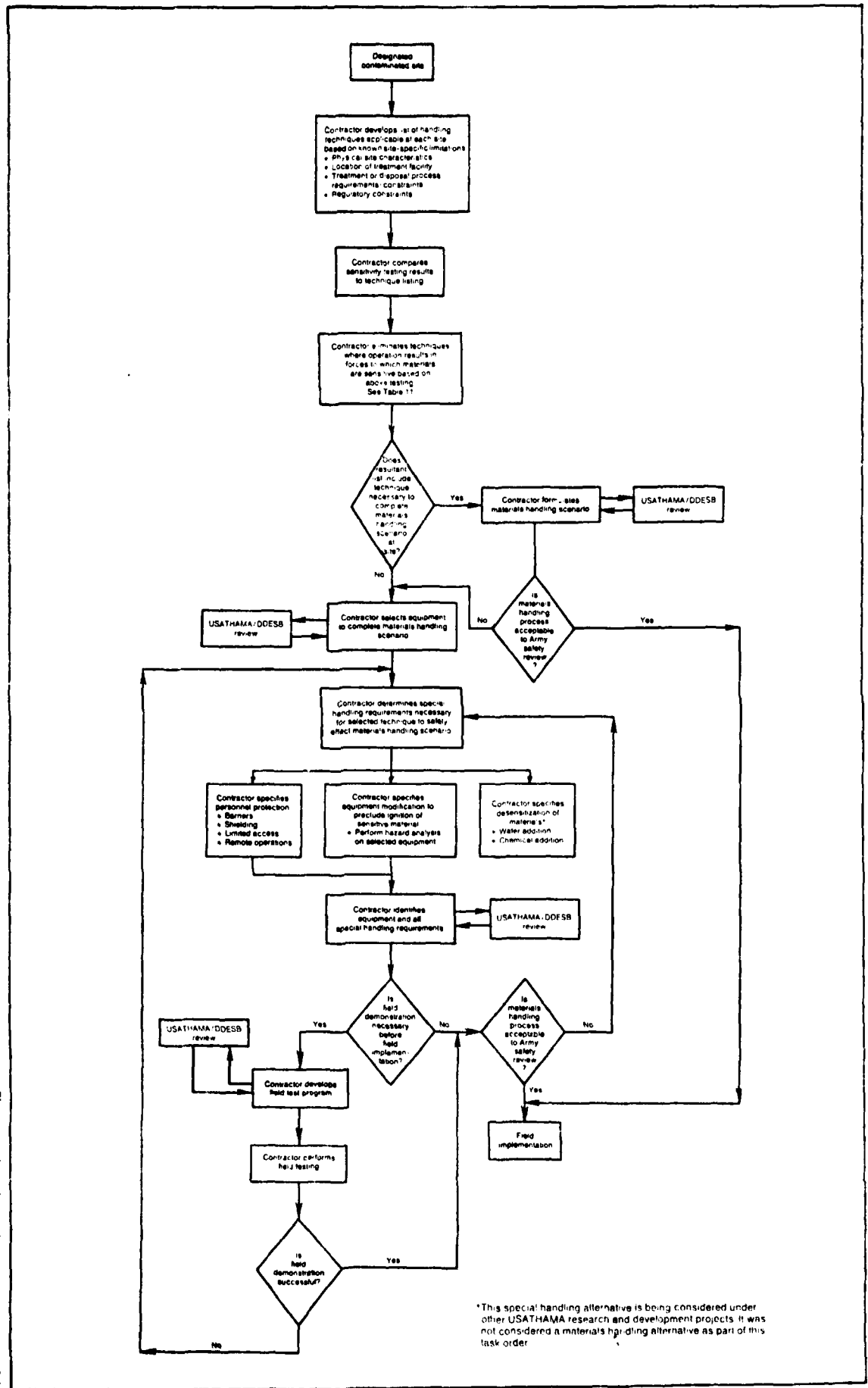

Figure 5. Decision matrix for selecting materials handling techniques.

*This special handling alternative is being considered under other USATHAMA research and development projects. It was not considered a materials handling alternative as part of this task order.

TABLE 2. POTENTIAL FORCES AND CONDITIONS FOR IGNITION PRESENT DURING OPERATION OF MATERIALS HANDLING TECHNIQUES

Materials handling techniques	Potential forces and conditions				
	Impact	Friction	Electrostatic	Thermal	Confinement
Excavation/removal					
Clamshell	X	X			
Dragline	X	X			
Front-end loader	X	X			
Backhoe	X	X			
Dredging	X	X			X
Vacuum removal	X	X	X		X
Transport¹					
Railroad car	X	X	X	X	X
Vehicular	X	X	X	X	X
Slurry pump	X	X		X	X
Conditioning or storage					
Mechanical screening	X	X			X
Containerization	X		X		
Mechanical dewatering	X	X	X	X	X
Delumper	X	X	X	X	
Wet grinding	X	X		X	
Storage vessel	X	X	X	X	X
Magazine storage	X		X	X	X
Treatment or disposal feed²					
Slurry pump	X	X		X	X
Hydrosluicing	X	X			
Belt conveyors		X	X	X	
Screw conveyors		X		X	X
Bucket conveyors		X	X	X	
Vibratory conveyors		X	X	X	
Pneumatic conveyors	X	X			X
Rotary feed		X		X	X
Manual feed	X				
Ram feed	X	X		X	X
Gravity feed via chute	X	X		X	

¹Generally includes transport over DOT-regulated highways and railways.

²May include short-distance transport (within site boundaries).

physical characteristics, proximity to treatment or disposal facility, restrictions imposed by the treatment or disposal facility, and regulatory constraints), the contractor will select the materials handling techniques that are applicable.

- (b) Determine special handling requirements. The contractor will compare the sensitivity testing results to the potential forces corresponding to each of the selected standard materials handling techniques. Based on this comparison, the contractor will modify or, if not possible, omit those materials handling techniques that will result in forces to which the site materials are sensitive.
- (c) Determine the necessity of field testing. The contractor will evaluate the proposed materials handling technique. If the technique has never been tested, or if the sensitivity of the material warrants, the contractor will recommend a field demonstration to test the proposed techniques.

2. BACKGROUND INFORMATION

2.1 General. Past operations at U.S. Army installations involved the manufacture, assembly, and handling of explosives and explosive devices. These operations, and disposal of carrier waters from these facilities, have resulted in explosives contaminated soils and sediments (hereinafter referred to as "materials") which may contain concentrations of up to 50 percent explosives (dry weight basis). If left untreated, the materials present a potential source of soil and groundwater contamination.

Treatment and handling operations for these materials will result in numerous safety concerns due to the potential for explosion. To date, these soils/sediments have not been handled or moved extensively and, consequently, no proven materials handling techniques/procedures have been developed that assure safety to both personnel and equipment.

2.2 Objectives. Based on the above situation, the objectives of this study are to:

- (a) Provide problem classification,
- (b) Establish materials handling performance criteria,
- (c) Develop a test scenario to determine which materials require special handling,
- (d) Identify state-of-the-art explosives handling techniques that may be adaptable to handling explosives contaminated materials,
- (e) Develop a typical explosives contaminated site work plan to be employed by the designated contractor,
- (f) Develop a materials handling protocol decision matrix to be employed by the designated contractor in conjunction with USATHAMA and the Army safety community,
- (g) Identify selected phases of a materials handling scenario that require limited laboratory/field testing before implementation, and
- (h) Prepare test plan(s) for those phases of a materials handling scenario selected by USATHAMA from item g.

Treatment of soils/sediments from contaminated sites requires the determination of a materials handling scenario. This requires evaluation of typical sites in terms of their physical and chemical characteristics, classification of the site in terms of its sensitivity, and identification of a materials handling protocol that will enable safe and efficient handling of explosives contaminated soils.

For this study, materials handling included: excavation/removal of contaminated materials from contaminated areas; transporting, conveying, or other forms of material movement from point of origin to disposal or treatment destination; and feeding or conveying materials into a treatment or disposal operation.

At this time, no state-of-the-art explosives materials handling technology has been identified for excavation or removal of materials from contaminated areas. Therefore, standard soil excavation/removal techniques were evaluated for such application.

This report includes discussion on storage and conditioning techniques for the contaminated materials. Whenever solid material is transported over any distance, some storage or surge capacity will be required. In addition, the materials may need to be preconditioned for subsequent treatment (e.g., addition of water to increase the moisture content of the soil, as required by the wet air oxidation treatment process). Several techniques used for preconditioning are presented to illustrate inherent sources of ignition and required modifications necessary to reduce the potential for ignition.

3. PROBLEM DEFINITION

3.1 General. Management of contaminated materials requires a materials handling process that enables removal of the material from the site, transport to a processing facility, and feed into the treatment or disposal process. Normally, this would be a straightforward activity, but the presence of explosives in the materials to be handled causes safety concerns due to the potential sensitivity of the material. For the purposes of this report, a sensitive material was defined as one which will chemically decompose when a specific force is applied to that material (such as impact, friction, electrostatic charge, or temperature increase). The decomposition is demonstrated by emission of smoke, fire, or, in the most severe case, an explosion.

3.2 Materials handling scenario. Materials handling of explosives contaminated soils/sediments comprises all activities including removal/excavation and feeding into a treatment or disposal process. The different aspects of handling of these materials are identified as follows: excavation/ removal, storage or conditioning, transport, and treatment or disposal feed system (see Figure 6). It is important to note that storage or conditioning may be an integral part of the materials handling scenario. Appendix A describes typical materials handling equipment as related to its applicability to these materials.

3.3 Sources of ignition. Materials that have been contaminated with explosive compounds must be considered sensitive (as defined in Subsection 3.1). In the materials handling process, forces may be encountered that will result in a reaction such as a fire or explosion. These forces are known as forces of ignition. The four forces which can initiate an ignition in materials handling scenarios are listed below:

- (a) Impact
- (b) Thermal
- (c) Friction
- (d) Electrostatic

These conditions were utilized as the basis for evaluating the various materials handling equipment and techniques.

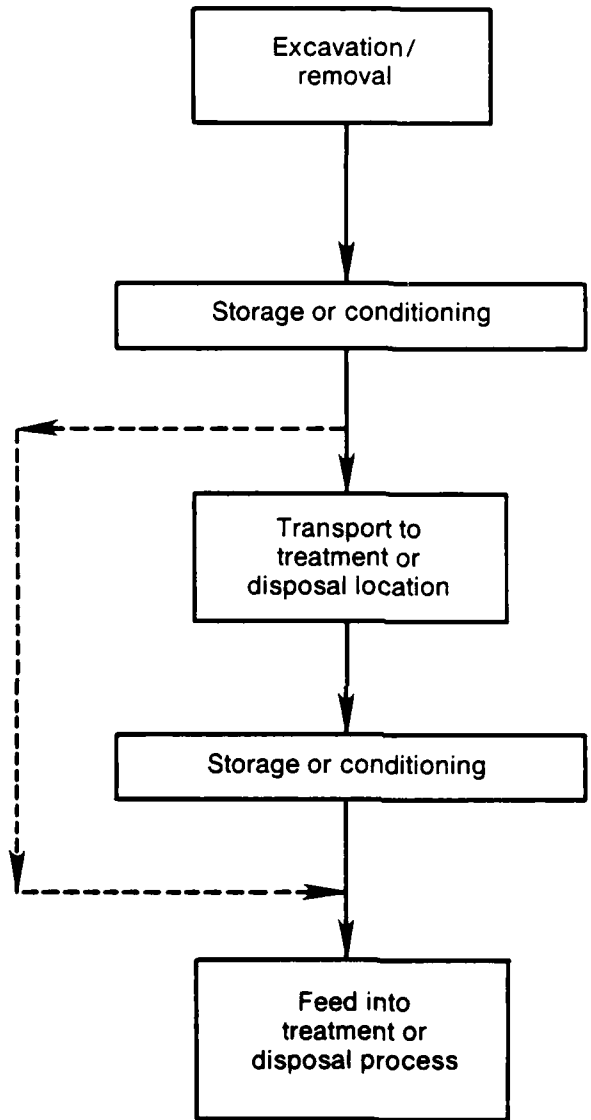

Figure 6. Typical materials handling scenario.

Ignition by impact results from a force of an object which collides with a sensitive material. Thermal ignition is evidenced during increasing temperature. Ignition by friction results from a force exerted when two materials rub against one another. Electrostatic ignition results from rapid movement of charged particles from one point to another (evidenced by a spark).

When selecting a materials handling technique, each technique must be studied to determine force(s) of ignition which may be encountered during operation of such technique and whether the applied force(s) (i.e., operating conditions) are of such magnitude as to result in ignition.

3.4 Conditions conducive to ignition. During any materials handling process, conditions may be encountered that result in increasing the sensitivity of the explosives contaminated materials. The two predominant conditions incurred during typical materials handling procedures that may increase sensitivity are:

- (a) Confinement, and
- (b) Moisture reduction.

Materials handling processes which increase these conditions effectively reduce the amount of force necessary to cause an ignition. These conditions must be carefully evaluated when selecting handling techniques for sensitive materials.

3.5 Site-characteristics. Site-specific variables such as moisture content, explosives concentration, and location of the treatment or disposal facility have direct implications on a given site's potential sensitivity. Data contained in the Installation Assessments conducted by USATHAMA in the late 1970's clearly illustrate differing site characteristics that will directly affect a materials handling protocol.

3.5.1 Moisture content. The data compiled in the Installation Assessments indicate that 55 percent of lagoons used to collect explosives manufacturing wastewater are wet (i.e., contain standing water). Although this condition might increase the potential for contaminant migration, the wet conditions decrease the sensitivity of the material. Adding moisture to potential explosive materials to decrease sensitivity of those materials has long been practiced in the explosives handling industry. This fact is also illustrated in the Department of Transportation (DOT) regulations for transporting explosives (49 CFR 173.212). According to these regulations, TNT or DNT (manufactured product) containing greater than 10-percent moisture may be shipped as a flammable solid as opposed to a classified explosive.

The nature of a wet site also places restrictions on the materials handling technologies which may be employed to excavate and transport the material. No longer can one operate a vehicle on the contaminated site without taking into consideration the site's ability to support the weight of that vehicle. Slurry pumping to treatment or slurry pumping followed by dewatering and transport are typical handling alternatives given this site condition. Another factor in the handling protocol which must be addressed is collection and treatment or disposal of the water at a wet site.

Although more physical difficulties will be encountered in removing materials from a wet site, the material is less hazardous from a sensitivity standpoint, and may minimize the need for special handling requirements.

3.5.2 Explosives concentration. Installation Assessment data indicate that 67 percent of lagoons located on Army production and storage facilities were employed for treatment of aqueous explosives wastes. These treatment processes resulted in contamination of lagoon sediments and soils. Based on WESTON's experience, concentrations up to 50-percent TNT (dry weight basis) have been identified in these lagoons. The concentration of explosives varies within a lagoon, with surface sediments usually being the most sensitive.

The sensitivity of such soils and sediments is directly proportional to the concentration of explosive contaminants at the site. Specific areas within a contaminated site may be acutely sensitive due to high explosives concentrations.

The explosives concentration profile, along with the potential existence of pockets of highly concentrated explosives, must be carefully evaluated on a site-specific basis before an effective materials handling scenario can be implemented.

3.5.3 Location of the treatment facility. One of the key aspects of the materials handling operation is the transport of the materials to a treatment or disposal facility. The location of this facility will have direct impact on selection of the transport materials handling equipment.

For example, one alternative may be an on-site treatment or disposal facility adjacent to the contaminated site. In this case, an efficient method of transport of the contaminated materials may involve some type of mechanical conveyor from the site to the facility.

Another alternative may involve an off-site treatment facility. In this case, the contaminated soils must be transported via truck or rail to the treatment or disposal facility. Such methods require adherence to all transport regulations. Preconditioning (such as adding moisture) of the removed materials may be required in order to conform with these regulations.

A third alternative may be a remotely located on-site treatment or disposal facility. This alternative may involve either mechanical conveyance, vehicular transport, or a combination of both, depending on the exact location of the treatment facility.

3.6 Materials handling performance criteria. Performance criteria were determined to aid the assessment of selected materials handling techniques for explosives contaminated materials. The development of these criteria accounts for the anticipated nonuniformity of the materials removed from a contaminated site, known sources of ignition (as discussed in Subsection 3.2) which affect specific materials handling techniques, and possible equipment design modifications. Table 3 lists performance criteria to be considered when selecting materials handling equipment.

TABLE 3. PERFORMANCE CRITERIA FOR MATERIALS HANDLING EQUIPMENT

-
- Minimize confinement of potentially sensitive materials.
 - Adaptable to handle materials of a nonuniform nature (particle size, moisture content, etc.).
 - Maintain all contact surfaces at or below 167°F.
 - Conform to all relevant Department of Defense design requirements for mechanism and structure which handle sensitive materials.^{1,2}
 - Employ design modifications to reduce potential of propagation within materials handling equipment.
 - Employ design modifications to minimize risk to operating personnel.
 - Employ materials of construction that are not conducive to maintaining an electric charge.
 - Employ materials of construction that are not conducive to sparking when in contact with sensitive materials.
-

¹Safety Manual, DARCOM Regulation Number 385-100, United States Army Material Development and Readiness Command, Alexandria, Virginia, 1981.

²Department of Defense Explosives Hazard Classification Procedures, Department of Defense, TB 700-2 (Army), Washington, DC, 1982.

4. SENSITIVITY TESTING

4.1 Reasons for sensitivity testing. Explosives contaminated soils and sediments create materials handling concerns. Each site will present different concerns that depend on the type of material, the moisture content of that material, and the concentrations of the explosives present. In addition to the material itself, the materials handling aspects (i.e., excavation/removal, transport, treatment/disposal feed, and storage or conditioning) may expose the material to various sources of ignition. Table 4 presents a matrix illustrating the sources and conditions of ignition that are anticipated at different stages of materials handling during a site decontamination operation.

Any sensitivity test plan must provide data that characterize contaminated materials in terms of the ignition sources and conditions. The identification of the critical sources and/or conditions of ignition will lead to the definition of specific design requirements for implementing a site-specific materials handling protocol that considers all special handling needs.

Many of the standard tests recommended for use in a reactivity/sensitivity test program are also required under RCRA for the classification of a hazardous waste. Therefore, the test program defined herein will also provide the regulatory information necessary to evaluate site-closure alternatives.

The determination of critical explosive parameters of contaminated materials using a reactivity/sensitivity test plan will lead to a materials handling protocol that will decrease the chances of an incident resulting in damages to man-power, structures, and equipment used in the site decontamination.

4.2 Sensitivity test methods. Table 5 summarizes sensitivity test methods applicable to explosives contaminated materials. The table includes a brief description of the excepted criteria for a positive result, and the purpose of each test in terms of regulatory acceptability and field application. Detailed descriptions of the sensitivity tests are contained in Appendix A.

4.3 Development of sensitivity test protocol. At this time the Bureau of Explosives, U.S. Department of Transportation (DOT), and the U.S. EPA have developed their own programs to determine reactivity/sensitivity of materials. It is expected that these organizations will make a joint effort to produce a standard sensitivity test program for all agencies handling reactive/sensitive materials. However, as of this time, no such plan has been proposed.

TABLE 4. ANTICIPATED SOURCES AND CONDITIONS OF IGNITION RELATED TO MATERIAL HANDLING CATEGORY

Sources and conditions of ignition	Material handling category			
	Excavation	Transport	Storage	Feed to treatment or disposal
Thermal			X	X
Friction	X	X		X
Electrostatic		X		X
Impact	X	X		X
Confinement	X	X	X	X
Moisture reduction	X	X	X	X

TABLE 5. SENSITIVITY TEST SUMMARY

Test	Trials	Description	Positive results	Purpose
Impact Bureau of Explosives (BOE)	10	Performed on BOE impact apparatus. Impact hammer drop at selected heights.	Explosion evidenced by flame or audible sound for any trial; smoke alone not positive.	BOE explosive classification. Co/no-go for materials handling methods. RCRA and DOT classification. ¹
Impact Bureau of Mines (BOM)	To be determined	Performed on BOM impact apparatus, 2-kg drop hammer is allowed to impact the sample. Equipment calibrated for energy impact as a function of drop height. ²	Same as above.	Produce engineering data to assess all facets of material handling.
No. 8 cap (detonation)	5	Insert blasting cap into sample which is placed in a paper cup resting on a lead block and then detonated.	Detonation (as evidenced by 1/8 in. compression of lead block for any trial).	BOE explosive classification. RCRA and DOT classification. ¹ Demonstrates sample's ability to propagate.
Spark	3	Insert electric igniter into sample, which is in paper cup. Paper cup on lead block on steel plate.	Deflagration evidenced by burning; detonation causes mushrooming of lead block in any trial.	BOE and DOT explosives classification. ³ Safety.
Friction	5	Sliding friction machine (or equivalent). Force applied hydraulically through stationary wheel to sample on anvil. Force 1,800 lb or as required to ensure 1 in. slide for anvil. Pendulum propels anvil at a known velocity, perpendicular to force. Reduce force selectively, then reduce velocity selectively if positive.	Ignition evidenced by production of flame, smoke, or distinct loud noise; or infrared detection of decomposition products for any trial.	Safety during field sampling and lab handling. Safety during all facets of materials handling.
Thermal stability	1	Heat to 1670F in oven for 48 hours. Sample in open or aluminum foil container.	Detonation; deflagration; or exothermic decomposition; some fuming/smoldering non-positive.	BOE and DOT explosive classification. ⁴ Safety during all facets of materials handling.
Fire	1	Container of sample subjected to fire; plastic container.	Explosion, as evidenced by a loud noise and projection of fragments.	Relevant to safe handling of flammable materials.

TABLE 5. CONTINUED

Test	Trials	Description	Positive results	Purpose
Cook-off	1	Container of sample is confined and heated to 1670° for 48 hours.	A positive result is evidenced by an audible sound or a projection of fragments.	Relevant to safety during operation of thermal processing equipment.
Electrostatic	10	Calibrated electrostatic spark jumps from pointed electrode to metal plate (serving as sample holder). Energy input should be set after preliminary testing. ⁵	Ignition as evidenced by flames, smoldering, or glowing for any trial.	Relevant to electrostatic spark initiation during field sampling and site materials handling procedures.
U.S. Gap (Bureau of Mines)	3	Sample in 16 in. long carbon steel tubing (1.44 in. i.d.). Cylinder bottom closed with 2 layers of poly sheet. Sample subjected to shock wave generated by detonation of a pentolite pellet. Steel witness plate, 1/8 in. thick, mounted at upper end of sample tubing and separated from it by spaces 0.063 in. thick, 2 in. gap, unambiguous separation between explosives and those sufficiently insensitive to transport.	Positive detonation if stable propagation velocity 1.5 km/sec measured; witness plate punched through; tube fragmented along its entire length. Any 2 out of 3 indicates positive result.	Demonstrates sample's ability to propagate. Test being studied by U.S. EPA for future reactivity testing.
U.S. Internal Ignition (Bureau of Mines)	3	Sample contained in 18 in. long, 3 in. schedule 80 carbon steel pipe capped at both ends with forged steel pipe caps. Sample subjected to thermal/pressure stimulus from ignitor capsule located at center of sample vessel.	Positive if either the pipe or at least one of the end caps is fragmented into at least 2 pieces for any trial.	Assesses thermal explosion hazard. Test being studied by U.S. EPA for future reactivity testing.

¹ HCCA hazardous waste classification for reactivity (40 CFR 261.23) as a Class A explosive defined by this task according to 49 CFR 173.53.

² Experimental drop height to be determined on a case-by-case basis.

³ This test for explosives is defined in the Federal Transportation Code, 49 CFR 173.5j, for initiating explosives.

⁴ This test defines a forbidden explosive (for transportation) according to 49 CFR 173.5l.

⁵ Actual magnitude of electrostatic charge to be 0.013 and 0.024 joules. It should be noted that the energy level generated by a human is in the 0.013 to 0.015 range according to the Allegany Ballistics Laboratory.

As a result, WESTON recommends an interim sensitivity test program which reflects the specific program needs related to excavation, transport, and treatment of explosives contaminated materials. Table 6 presents criteria employed to select the sensitivity tests necessary to determine contaminated materials handling options. Table 7 lists specific sensitivity tests and source or condition of ignition simulated by the test.

4.4 Recommended sensitivity test program. The following sensitivity test program is recommended for use with explosives contaminated materials:

- (a) Impact test (Bureau of Explosives)
- (b) Friction test
- (c) Electrostatic test
- (d) U.S. gap test
- (e) Thermal stability test

The selection of these tests as the basis of the sensitivity test program was based on the selection criteria presented in Table 6, along with best engineering judgment resulting from WESTON's past experience in developing sensitivity test programs (WESTON, 1984).

These tests include at least one sensitivity test for each identified source or condition of ignition. In the cases where multiple tests existed for specific ignition source or condition, the sensitivity test that was assessed to be most representative of actual materials handling techniques was selected. (This was the case for the BOE Impact Test and the U.S. Gap Test.)

Additional sensitivity tests may be required as a result of the selected materials handling protocol. For example, if contaminated soil will be transported by vehicles on public highways, DOT regulators may require testing to determine the explosives class of the material. A typical test required by the DOT as part of this classification is the No. 8 cap (detonation) test described in 49 CFR 173.53. This test has no implication on the sensitivity of materials in terms of handling, but will likely be a required test by regulatory agencies.

Actual application of these sensitivity tests to material samples is discussed in Section 5.

TABLE 6. CRITERIA FOR SELECTING NECESSARY SENSITIVITY TESTS

-
- Utilize tests that simulate sources or conditions of ignition expected to be encountered in materials handling operations.
 - Select standard tests where possible so that existing data bases and experience can be applied for comparison purposes.
 - Select tests that can be executed by any commercial laboratory qualified for explosives testing.
 - Address Department of Army concerns for safe operating conditions for personnel and equipment.
 - Address anticipated safety considerations for both manpower and equipment.
-

TABLE 7. SENSITIVITY TEST METHODS RELATED TO ANTICIPATED SOURCES OR CONDITIONS OF IGNITION

Test	Source or condition of ignition					Moisture reduction ¹
	Thermal	Impact	Electrostatic	Friction	Confinement	
Impact (Bureau of Mines)		X				X
Impact ² (Bureau of Explosives)		X				X
No. 8 cap (detonation)		X			X	X
Spark	X					X
Electrostatic ²			X			X
Friction ²				X		X
Thermal stability ²	X					X
Fire	X					X
Cook-off	X				X	X
U.S. gap ² (Bureau of Mines)	X	X			X	X
U.S. internal ignition (Bureau of Mines)	X				X	X

Note: ¹Moisture reduction as a tested condition can be established for all tests.

²Denotes test is part of recommended test program.

5. DEVELOPMENT OF MATERIALS HANDLING PROTOCOL

5.1 General. Materials handling protocol for explosives contaminated sites will be developed using the multi-step procedure illustrated in Figure 7. Initially, each site will undergo a detailed site categorization which will include:

- (a) Site assessment,
- (b) Field sampling and chemical analysis, and
- (c) Sensitivity testing.

Specifics of the site categorization are discussed in Subsection 5.2.

Data developed in the site categorization will be applied to a technique selection decision matrix which will determine:

- (a) Special handling requirements,
- (b) Level of personnel protection required, and
- (c) Equipment modifications.

This decision matrix is presented in Subsection 5.3.

The application of the technique selection decision matrix will result in a materials handling scenario for the explosives contaminated materials that will reduce the initiation potential to an acceptable level.

5.2 Site categorization. Site categorization will be completed in three stages:

- (a) Site assessment,
- (b) Field sampling and chemical analysis, and
- (c) Sensitivity testing.

5.2.1 Initial site assessment. The following activities will comprise the site assessment:

- (a) Data package provided to contractor by USATHAMA,
- (b) Site visit by contractor, and
- (c) Development of a geophysical test program by contractor.

This listing includes both USATHAMA and contractor action items.

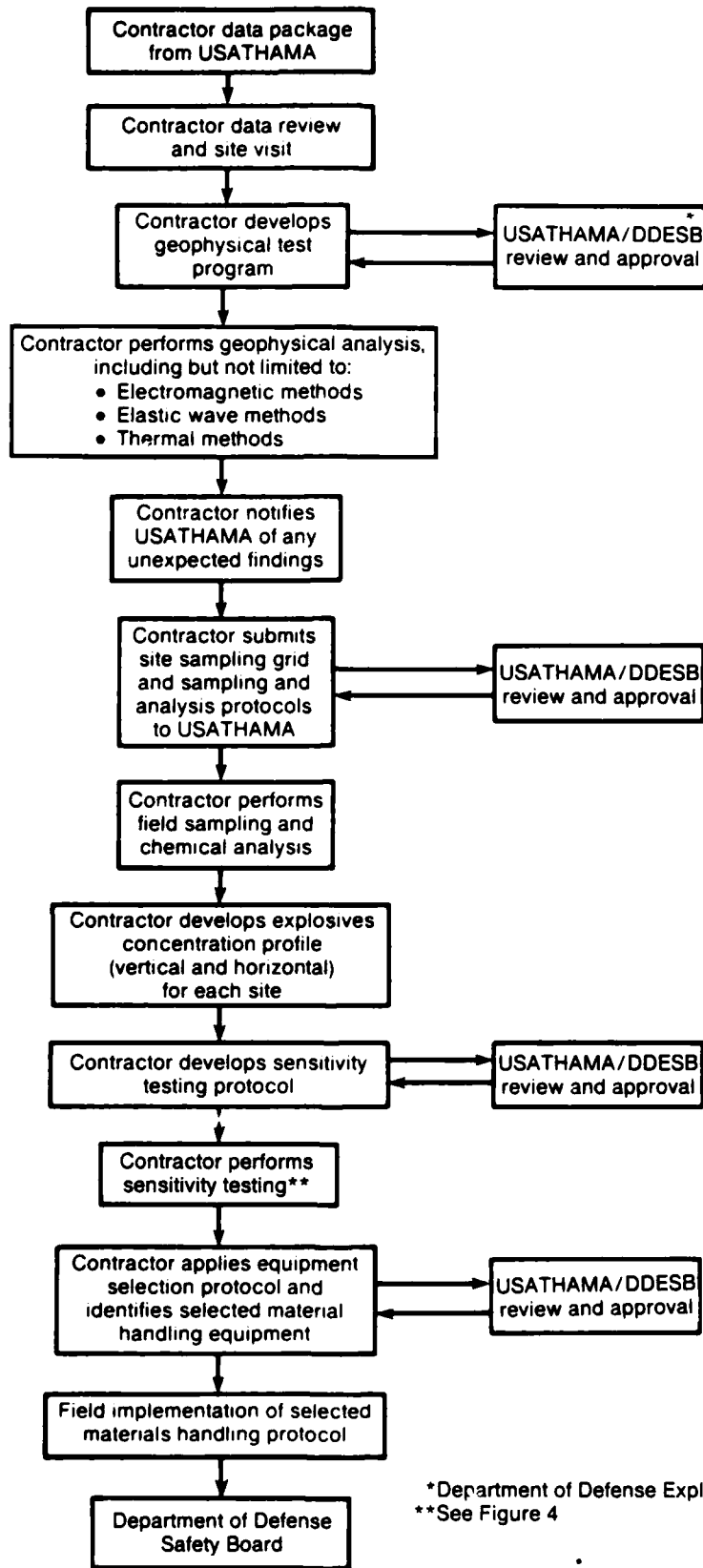

*Department of Defense Explosives Safety Board
 **See Figure 4

Figure 7. Materials handling protocol.

Table 8 lists the data a contractor will need in order to develop the initial action plan. The data package for each contaminated site (provided by USATHAMA) should include a site map indicating site access points, the present conditions (wet and dry), current status (active/inactive), recorded waste handling history, and manufacturing record of the facility at which the site is located. A contractor must assume that records documenting site activities may not be available, and, in such cases, best engineering judgment along with input from the USATHAMA project team will be necessary in developing site work plans.

The site visit by the contractor will include the following activities:

- (a) Interviews with designated facility personnel,
- (b) Review of facility documents relevant to the site, and
- (c) Photodocumentation of the site.

The purpose of the site visit by the contractor is to both confirm data reported in the USATHAMA data package and to obtain additional information necessary to develop the geophysical test program. In addition, all identified data gaps should be resolved during this site visit.

Following the site visit, a geophysical test program will be developed. The objectives of this program will be to:

- (a) Identify any unexploded ordnance (UXO),
- (b) Attempt to identify any pockets of concentrated contaminants contained within the site,
- (c) Attempt to identify/confirm the geologic substructure of the site, and
- (d) Attempt to identify any foreign objects contained within the designated site.

A typical geophysical test program will involve the performance of at least two different test procedures. An example of a dual test procedure is ground penetrating radar (GPR) and electromagnetic conductivity. The data generated can determine where contamination exists using the change of the area's electromagnetic conductivity compared to background levels, while using the GPR to determine if the conductivity change results from buried containers, etc. The test selections should produce complimentary data which will facilitate subsurface mapping. A subsurface survey is accomplished in the steps outlined below:

TABLE 8. SUMMARY OF ITEMS CONTAINED IN THE
USATHAMA DATA PACKAGE

-
- Facility map indicating location of designated site and anticipated access points.
 - Location and size of designated site.
 - Current site conditions.
 - Operational and/or disposal history of site.
 - Operational history of facility at which site is located.
 - Any data reflecting status of groundwater, surface water, and soils at site.
 - Reported geology of site, if available.
 - All applicable environmental assessments of site.
 - Current operational status.
 - Location and operability of environmental monitoring points surrounding the site.
 - Photodocumentation of site, if available.
-

- (a) A grid covering the designated area is established to provide location coordinates for all geophysical tests.
- (b) The equipment is passed either manually or via a survey vehicle over the sample grid. Data produced by the survey instrument are sent to a recorder for evaluation at a later date.
- (c) The data generated by all geophysical tests are analyzed and conclusions of all tests performed are combined to produce a vertical and horizontal view of the subsurface.

A summary of geophysical tests is presented in Table 9. A report summarizing the analyzed data highlighting all unusual findings must be submitted to USATHAMA to complete this portion of the site categorization.

5.2.2 Field sampling and chemical analysis. Upon successful completion of subsurface mapping, the contractor will develop a sampling and analysis plan. The primary objective of this plan will be to provide data to estimate the vertical and lateral extent and volume of contamination at the designated site. The plan, which will be submitted to USATHAMA by the contractor, must contain the following information:

- (a) Sampling location grid,
- (b) Sampling procedures,
- (c) Sampling safety plan, and
- (d) Analytical procedures.

As a minimum, the plan will require surface and two core samples at varying depths at each sampling point. The depths will be determined on a site-by-site basis.

The sampling safety plan will be based on information developed from the subsurface mapping and the initial USATHAMA data package. The plan should detail sampling equipment selection and personal protection requirements necessary for completion of sampling activities.

For determination of special handling procedures, it will be necessary to perform analyses of all material samples for explosives concentration. The method to be used for the analyses is a USATHAMA Method 8H developed jointly by WESTON and USATHAMA as part of Contract No. DACA87-82-C-0063, Task Order 1. (This method is described in Appendix B.) Additional chemical analyses may be required to further classify the material prior to disposal (e.g., EP Toxicity to determine metals leachability from material).

TABLE 9. SUMMARY OF CURRENTLY AVAILABLE GEOPHYSICAL TEST PROCEDURES APPLICABLE AT EXPLOSIVES CONTAMINATED SITES

Test methods	Description	Typical applications	Comments
<p>Thermal</p> <ul style="list-style-type: none"> - Infrared - Heat pulse 	<p>Method utilizes thermal radiation from a heated surface which is measured by an infrared radiometer. Heating can be either active or ambient. The radiation pattern reveals heat flow anomalies caused by imperfect structural properties and flaws.</p>	<p>Determine location of buried objects, water flow profiles within dams, and heat escaping from surface objects.</p>	<p>Surface detection of heat loss is most applied usage of this test method. Sub-surface reliability is questionable.</p>
<p>Elastic wave</p> <ul style="list-style-type: none"> - Seismic refraction - Seismic reflection - Ultrasonics - Sonar 	<p>A force (impulse) is generated either at or below surface of soil or water. The waves generated from the source are received by a series of transducers. If well defined layers are present, there will be a characteristic series of return echoes at specific time intervals.</p>	<p>Seismic refraction and reflection have been valuable in determining depth to bedrock (important when considering in situ treatment of site).</p> <p>Sonar operates successfully only when immersed in water. Method used to probe water bottoms.</p>	<p>The most common methods employed for field investigations are seismic refraction and reflection (determining dimensions of a contaminated site).</p>
<p>Electromagnetic</p> <ul style="list-style-type: none"> - Resistivity - Metal detection - Pulsed radio frequency (GM) - Continuous radiowave frequency - Continuous microwave - Magnetometer - Ground penetrating radar (GPR) - Electromagnetic (EM) conductivity 	<p>All devices generate an electromagnetic pulse. Pulse travels through subsurface until it encounters an interface with differing material. The pulse is either reflected or the transmitted field is altered. Measurements of this deflection are taken and analyzed to determine the nature of the object which caused the deflection.</p> <p>Resistivity, metal detection, and EM conductivity respond to changes of conductivity/resistivity of a site. Pulsed radio frequency, continuous microwave, and GPR respond to changes in dielectric constants and conductivity. A magnetometer responds to changes in the magnetic field based on prevailing magnetic field at the site.</p>	<p>These tests are current state-of-the-art geophysical test procedures for determining depth and location of foreign objects at hazardous waste sites and definition of subsurface geological makeup of the designated site. Two or more electromagnetic methods should be employed at a designated site so one can further increase the certainty of data interpretation. Each test has varying degrees of effectiveness with depth.</p>	<p>Function of equipment is dependent on area being sampled. Penetration levels vary from 5 to 100 feet depending on soil type and moisture levels. (Wet clays will attenuate electromagnetic signals.) GPR and EM conductivity are the most common geophysical tests employed for subsurface mapping at hazardous waste sites.</p>

5.2.3 Sensitivity testing. Section 4 of this report explains the sensitivity test selection process for explosive contaminated materials. The tests recommended are:

- (a) Impact test (Bureau of Explosives)
- (b) Friction test
- (c) Electrostatic test
- (d) U.S. gap test
- (e) Thermal stability test

Table 10 lists the test conditions recommended for the performance of sensitivity tests on explosives contaminated materials. All materials will be air dried for 72 hours before sensitivity testing is executed. A soil or sediment will be considered sensitive to the specific ignition force or condition being tested (thus meriting special handling) if any one trial of a specific test is positive based on the established positive criteria listed in Table 10.

The sensitivity testing program illustrated in Figure 8 is designed to limit the number of samples submitted for sensitivity testing, yet will provide the information to characterize a site. The program focuses on those samples that contain the greatest concentration of an explosive contaminant as identified by chemical analysis. The testing will continue until all soil samples in a test lot (10 samples) fail all sensitivity tests or until all soil samples have been tested.

At this time all sensitivity testing must be executed at a laboratory specifically equipped for the performance of these tests. Therefore, samples must be transported to the designated laboratory. At least 10 pounds of sample (prior to air drying) is required for completion of the recommended protocol.

5.3 Selection of equipment. Upon completion of sensitivity testing, the necessary information will have been acquired so that selection of equipment for materials handling of explosives contaminated soils/sediments can be completed. This subsection discusses the basis for selection of materials handling equipment focusing on site-specific and equipment-specific conditions that influence this determination. In addition, a logic diagram is developed for the determination of special handling requirements for the removal and transport of the designated soils/sediments.

TABLE 10. SENSITIVITY TEST PROTOCOL

Sensitivity test	Test conditions	Trials	Positive result
Impact (BOE)	Drop height: 14 in. Sample size: 17 mg Apparatus: BOE impact device	10	Any one trial resulting in a visual flame or audible sound.
Friction	Friction force: 1,800 psi* Velocity: 8 ft/sec Apparatus: Sliding friction machine	5	Any one trial exhibiting flame, smoke, or audible sound.
Electrostatic	Spark energy: 0.024 joules Sample size: Approximately 50 mg unconfined Apparatus: Electrostatic test device	3	Any one trial resulting in flaming, glowing, or smoldering.
U.S. gap	Confined sample in 1.45 in. diameter by 16 in. long tube Initiation source: 2 in. diameter by 2 in. long pentolite booster Sample size: Approximately 1.5 lb**	3	Any one trial resulting in two of three following conditions: (a) Propagation velocity of 1.5 kg/sec. (b) Rupture of witness plate. (c) Tube fragmented along entire length.
Thermal stability	Sample size: 10 g Test temperature: 167°F	1	Detonation: Deflagration or exothermic decomposition.

Note: All samples are to be air dried for 72 hours before testing. It is estimated that total sample size required is 10 lb prior to air drying for completion of this protocol.

*1,800 psi or the highest standard test level where the anvil would slide a distance of 1 inch at an initial velocity of 8 ft/sec.
**Sample size noted is air dried weight.

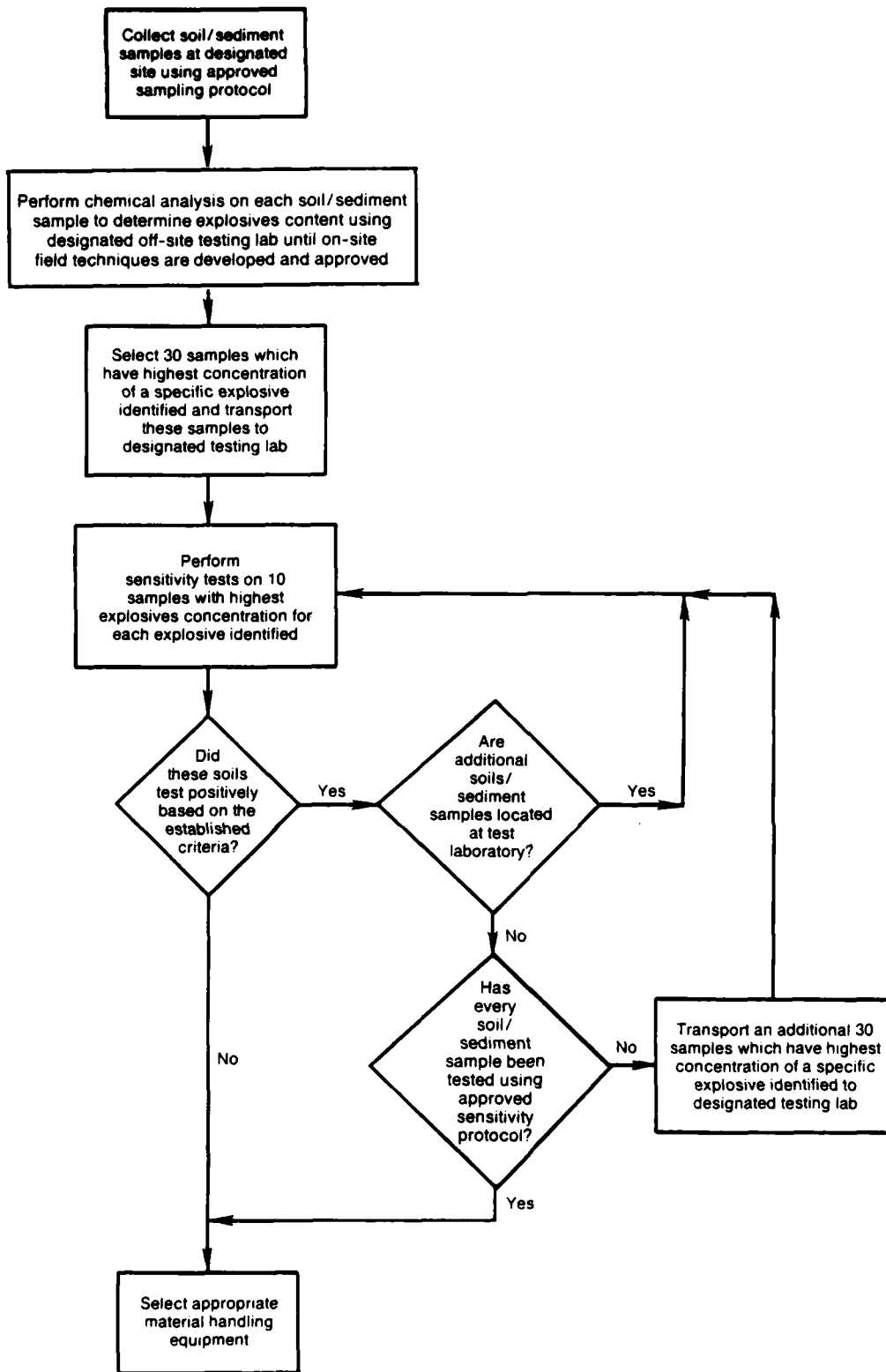

Figure 8. Sensitivity testing protocol.

5.3.1 Basis for equipment selection. The materials handling protocol developed thus far has focused primarily on sensitivity of materials (considered a function of explosives concentration). In terms of personnel safety, sensitivity of the material is the primary criteria. In terms of physically handling the contaminated soils and sediments from removal to treatment or disposal, additional factors must be taken into account. Factors which will influence the selection of materials handling equipment for explosives handling sites are:

- (a) Physical condition of site:
 - Moisture content
 - Accessibility
 - Topography
- (b) Location of treatment or disposal facility:
 - On-site local
 - On-site remote
 - Off-site
- (c) Treatment or disposal process requirements/constraints:
 - Feed requirements
 - Pre-conditioning
 - Acceptable moisture level
- (d) Regulatory constraints:
 - Federal
 - State
 - Local

These factors are clear indicators that site conditions and the selected treatment or disposal process form an additional basis for selecting relevant materials handling procedures for the removal, transport, and feed of explosives contaminated materials.

5.3.2 Sensitivity zones. Upon completion of chemical analysis of soil and sediment samples and all required sensitivity tests, horizontal and vertical contamination and sensitivity profiles will have been developed. The sensitivity profiles will identify the specific areas in which the selected special handling techniques must be employed.

There is the possibility, especially on large sites, that the specific areas which are considered sensitive (based on sensitivity testing) are small compared to the total site area. In these cases, it is recommended that the contractor develop a multi-phase materials handling protocol which would establish different materials handling scenarios for materials of differing sensitivity. An example of this situation would be a site with an identified sensitive soil layer of 3 inches. In this case, it may be more efficient to use two excavation devices, one for the sensitive layer and another for the nonsensitive layer.

The multi-phase application of materials handling equipment may not be appropriate at every site, but should be considered as part of the decision making process for special handling requirements.

5.3.3 Determination of materials handling scenario. Figure 9 presents the decision diagram for selecting materials handling equipment for explosives contaminated sites. This diagram is based on the materials handling equipment identified in Appendix A and assumption of completion of the site categorization plan presented in Subsection 5.1.

The contractor will select materials handling equipment capable of removing and transporting materials, based on site and treatment limitations discussed in Subsection 5.3.1. The contractor will then compare sensitivity test results to the ignition forces and conditions present during the operation of the selected materials handling equipment. A summary of operational ignition forces and conditions for materials handling equipment is presented in Table 11.

At this point the contractor must rely on past experience and good engineering judgment to determine if the selected equipment can successfully and safely complete a materials handling scenario (from removal to feed of a treatment or disposal process) at the designated site. If so, the contractor formulates a materials handling scenario, subject to USATHAMA review and approval. The materials handling scenario must also be approved by the Army safety community before field implementation. If not, the development of special handling techniques will be required, i.e., process or equipment modification, material preconditioning, etc. It may be determined that field testing or laboratory demonstration of the developed techniques are necessary before field implementation.

Within the scope of this report, two alternative approaches to fulfillment of special handling requirements are available:

- (a) Personnel protection, and
- (b) Equipment modification.

Personnel protection modifications include construction of barriers and shielding, limiting personnel access to all operating equipment, and/or specifying equipment to operate remotely.

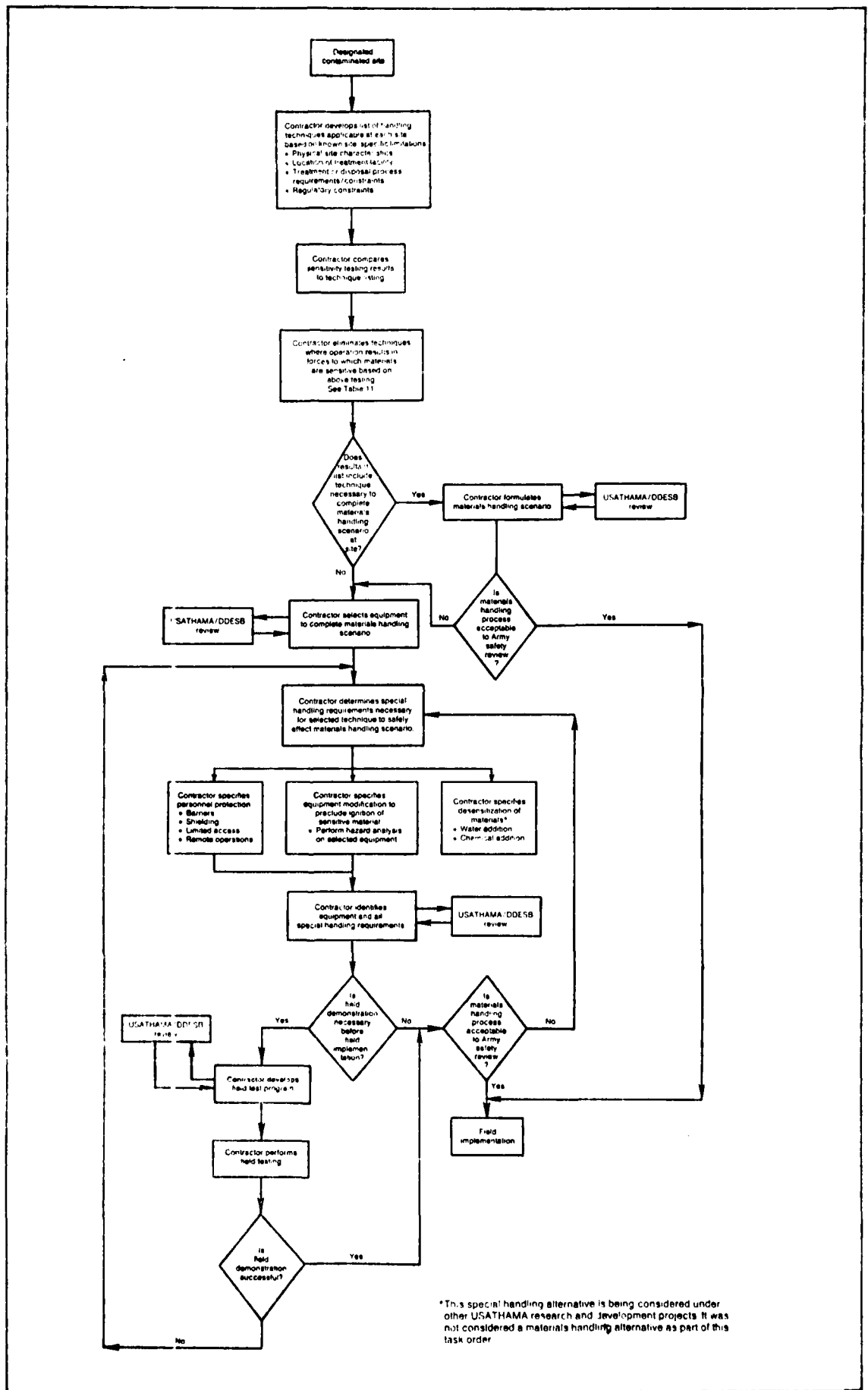

Figure 9. Decision matrix for selecting materials handling techniques.

*This special handling alternative is being considered under other USATHAMA research and development projects it was not considered a materials handling alternative as part of this task order.

TABLE 11. IDENTIFIED SOURCES/CONDITIONS FOR IGNITION PRESENT DURING OPERATION OF THE LISTED MATERIALS HANDLING EQUIPMENT

Materials handling techniques	Identified sources/conditions for ignition				
	Impact	Friction	Electrostatic	Thermal	Confinement
Excavation					
Clamshell	X	X		X	
Dragline	X	X		X	
Front-end loader	X	X		X	
Backhoe	X	X		X	
Dredging	X	X			X
Vacuum removal	X	X	X		X
Transport					
Railroad car	X	X	X	X	X
Vehicular	X	X	X	X	X
Slurry pump	X	X		X	X
Hydrosluicing	X	X			
Conditioning/storage					
Mechanical screening	X	X			X
Containerization	X		X		
Mechanical dewatering	X	X	X	X	X
Delumper	X	X	X	X	
Wet grinding	X	X		X	X
Storage vessel	X	X	X	X	
Magazine storage	X		X	X	X
Treatment feed/short distance transport					
Slurry pump	X	X		X	X
Hydrosluicing	X	X			
Belt conveyors		X	X	X	
Screw conveyors		X		X	X
Bucket conveyors		X	X	X	
Vibratory conveyors		X	X	X	
Pneumatic conveyors	X	X			X
Rotary feed		X		X	X
Manual feed	X				
Ram feed	X	X		X	X
Gravity feed via chute	X	X		X	

Equipment modification should be initiated with a hazards analysis. This analysis is a comparison of the forces generated by the operation of the materials handling apparatus versus the forces required for an initiation of the given soil or sediment. The results of a study of this type will generate an initiation curve when input force is plotted versus a specific operating parameter such as sample amount, temperature, or velocity of a moving part of the materials handling apparatus. Figure 10 gives an example of a typical hazard analysis for equipment operation. Once operation ignition forces or conditions are identified, design and operating changes may be implemented to eliminate the identified safety hazard(s).

An additional means of reducing the potential of an ignition during a materials handling process would be to decrease the sensitivity of the material by adding either water or another known desensitizing agent (pre-conditioning). Although this would be an acceptable practice in field application, it was not considered a special handling technique within the scope of this report.

Upon determination of all special handling requirements for selected equipment, the contractor will submit the entire materials handling process design (with all special handling requirements) to USATHAMA for review. At that time, USATHAMA will determine if field demonstration or testing of the handling technique is necessary. If so, the contractor will develop a field test program designed to examine the ability of the special handling equipment modification to reduce ignition forces or conditions and/or potential for personnel injury due to an ignition. The test program will be subject to USATHAMA review. Upon completion of a successful demonstration, the materials handling process will be submitted for Army safety review prior to field implementation.

If field testing is not determined to be necessary, the proposed materials handling process will be submitted for Army safety board review prior to field implementation.

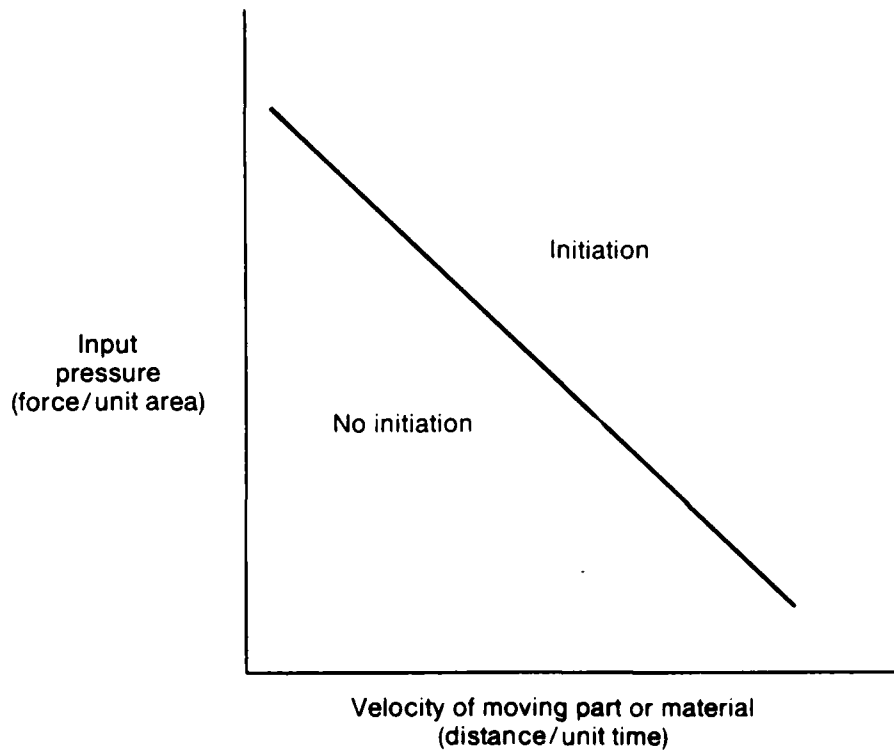

Figure 10. Typical hazard analysis.

6. CONCLUSIONS AND RECOMMENDATIONS

6.1 Conclusions.

- (a) Materials handling techniques which have been employed as state-of-the-art explosives handling equipment are adaptable to transport, store or condition, and to feed contaminated materials into a treatment or disposal process.
- (b) At this time, solid explosives or other sensitive materials are not handled by equipment necessary to excavate an explosives contaminated site.
- (c) Primary forces and conditions of ignition present in typical materials handling processes are impact, friction, heat, electrostatic, confinement, and reduction of moisture.
- (d) The materials handling scenario will be affected by site conditions, physical characteristics of the materials, selected treatment or disposal process, and the location of treatment or disposal facilities. As a result, no one technology or system can be identified as "most suitable."
- (e) Detailed site studies are necessary to establish the data base for developing materials handling techniques. These studies must identify any unexploded ordnance (UXO) on-site.
- (f) Geophysical testing is necessary to aid in identifying unexploded ordnance and pockets of concentrated explosives at each site.
- (g) Chemical analysis procedures have been developed to determine explosive concentration in soil media.
- (h) No standard sensitivity test protocol has been developed by regulatory agencies for determining site sensitivity when explosives contamination has been identified; however, agencies such as the Bureau of Explosives and the Bureau of Mines have developed and applied specific sensitivity tests on explosive materials.

- (i) Standard equipment may be applied with sensitive soils if additional personnel protection precautions have been employed on-site or as part of equipment modification. These additional precautions are considered special handling requirements.

6.2 Recommendations.

- (a) Each site must undergo a detailed site categorization as presented in Subsection 5.2 (see Figure 9). This program must include:
 - Geophysical survey to include at least two complimentary procedures to attempt to identify any suspicious material or pockets of concentrated explosives.
 - Core and surface sampling with chemical analysis for explosives to determine vertical and horizontal contamination profiles.
 - Limited sensitivity testing on samples with highest concentration of explosives using decision matrix presented in Figure 9.
- (b) Technique selection for materials handling of explosives contaminated soils and sediments will be performed using the decision diagram presented in Subsection 5.3 (Figure 9) with the accompanying operational force of ignition chart for materials handling techniques (Table 11). The actions occurring as part of this decision diagram are summarized below:
 - Determination of the applicability of standard equipment based on sensitivity testing at site.
 - Determination of special handling requirements at an explosives contaminated site.
 - Determination of the need for a field test of selected equipment.
- (c) A bottleneck in timing sequence for site categorization is likely to be the performance of chemical analysis and sensitivity testing on material samples. At this time, these samples must be packaged and shipped to designated laboratories for analysis and testing. It would be to USATHAMA's advantage to develop mobile laboratories to perform the necessary chemical and sensitivity testing. This development may be in conjunction with the laboratories in which the chemical and sensitivity tests are performed. A mobile testing laboratory on-site should reduce testing time and may increase personnel safety since on-the-spot testing for explosives can occur.

- (d) WESTON recommends that no test plan be developed for any specific materials handling procedure identified at this time. The findings of this report can best be tested by implementing a site remediation using the proposed decision matrix and technique selection diagram illustrated in Figure 9 and Table 11, respectively. The basis of this recommendation reflects differing constraints which are likely to be site-specific.

7. REFERENCES

Chemical Engineering Volume 87, No. 12, 16 June 1980.

Code of Federal Regulation, Transportation, Title 49, Office of the Federal Register, Washington, DC, 1983.

Department of Defense Explosives Hazard Classification Procedures, Department of Defense, TB 700-2 (Army), Washington, DC, 1982.

DOD Contractor's Safety Manual for Ammunition, Explosives, and Related Dangerous Material, Department of Defense, DOD4145.26M, 1968.

DOD Explosives Safety Manual, U.S. Department of Energy, DE82-015603, Washington, DC, 1982.

Engineering Design Handbook, Explosives Series: Properties of Explosives of Military Interest, U.S. Army Material Command, Washington, DC, 1971.

King, C.J., Separation Processes, McGraw Hill Book Company, New York, 1971.

Kirk-Othmer Encyclopedia of Chemical Technology, 2nd edition, Volume 8, John Wiley and Sons, New York, 1965.

Lord, A.E., Jr., S. Tyagi, and R.M. Koerner, "Nondestructive Testing (NDT) Methods Applied to Environmental Problems Involving Hazardous Materials Spills," Proc. 1980 National Conference on Control of Hazardous Material Spills, 13-15 May 1980, Louisville, Kentucky, 174-179.

Lord, A.E., Jr., R.M. Koerner, and J.E. Brugger, "Use of Electromagnetic Wave Methods to Locate Subsurface Anomalies," Proc. U.S. EPA National Conference on Management of Uncontrolled Hazardous Waste Sites, 15-17 October 1980, Washington, DC, Hazardous Materials Control Research Institute, Silver Spring, Maryland, 119-124.

Marks, L.S. and T. Baumeister, Standard Handbook for Mechanical Engineers, 7th edition, McGraw Hill Book Company, New York, 1967.

Perry, R.H. and C.H. Chilton, Chemical Engineer's Handbook, 5th edition, McGraw Hill Book Company, New York, 1973.

Personal communication with Frank Kaistoff, Radford AAP, 31 August 1984.

Personal communication with Cornhusker AAP, 5 April 1984.

Personal communication with Dan Hill, U.S. Army AED, 13 March 1984.

Personal communication with Paul Horrox, Rexnord, Inc., Carrier Division, 2 October 1984.

Personal communication with Joseph DiGiovanni, Allegany Ballistics Laboratory, 14 September 1984 and 16 October 1984.

Peurifoy, R.L. (editor), Construction, Planning, Equipment, and Methods, 2nd edition, McGraw-Hill, New York, 1970.

Safety Manual, DARCOM Regulation No. 385-100, United States Army Material Development and Readiness Command, Alexandria, Virginia, 1981.

Vendor Information: FMC Corporation, Link-Belt Division.

Vendor Information: Pennwalt, Sharples Division.

Vendor Information: Rexnord, Inc., Carrier Division.

Vendor Information: Vibra-Screw, Inc.

Vendor Information: Air Engineering Systems Corporation.

Visitation and technical transfer at Allegany Ballistics Laboratory, 30 August 1984.

Visitation and technical transfer at Toelle Army Depot, Toelle, Utah, 26 January 1984.

Weston, Roy F., Inc., "Engineering Analysis of Alternative Remedial Measures: Savanna Army Depot Activity (SADA)," Prepared for USATHAMA, Contract Number DACA87-82-C-0063, Task Order 1, Roy F. Weston, Inc., West Chester, Pennsylvania, November 1984.

Yaffe, H.J., N.L. Cichowicz, and P.J. Stoller, "Remote Sensing for Investigating Buried Drums and Subsurface Contamination at Coventry, Rhode Island," Proc. U.S. EPA Solid and Hazardous Waste Research Division's Annual Symposium, Washington, DC, March 1981.

APPENDIX A
MATERIALS HANDLING TECHNIQUES

5449A

APPENDIX A

MATERIALS HANDLING TECHNIQUES

A.1 General. The following subsections provide detailed descriptions of the materials handling technologies identified via literature review and personal contact with various manufacturers. These technologies include state-of-the-art explosives handling and other adaptable solids handling techniques. The technologies fall into four broad application categories: excavation/removal, transport, conditioning or storage, and feed systems. The technologies and application categorization are summarized in Table A-1.

The presentation of these materials handling technologies includes a process description, potential sources or conditions of ignition inherent to the equipment's operation, applicability to differing site characteristics, and potential design and operating changes which will reduce the potential for ignition.

TABLE A-1. TECHNIQUE SUMMARY

Materials handling technology	Excavation/ removal	Transport ¹	Conditioning or storage	Treatment or disposal feed ²
Clamshell	X			
Dragline	X			
Front-end loader	X			
Backhoe	X			
Dredging	X			X
Vacuum removal transport	X			X
Railroad car transport		X		
Vehicular transport		X		
Mechanical screening			X	
Containerization			X	
Mechanical dewatering: centrifuge			X	
Delumper			X	
Wet grinding			X	
Storage vessel			X	
Magazine storage			X	
Slurry pump		X		X
Hydrosluicing				X
Belt conveyors				X
Screw conveyors				X
Bucket conveyors				X
Vibratory conveyors				X
Pneumatic conveyors				X
Rotary feed system				X
Manual feed				X
Ram feed system				X
Gravity				X

¹Generally includes transport over DOT-regulated highways and railways.

²May include short-distance transport (within site boundaries).

CLAMSHELL

- (a) Materials handling application: Excavation.
- (b) History in explosive materials handling: A clamshell with no design modifications has been reported to have been used to excavate explosives contaminated sediments from a wastewater treatment lagoon at a specific Army installation without adverse effects. These sediments contained 10 to 15 percent TNT (dry basis) with trace quantities of RDX and 30 to 40 percent moisture.
- (c) Description: This unit employs a bucket attached to a crane. The length of the crane determines the reach of the bucket. The unit is usually operated from a cab which is part of the unit. The unit is mounted on crawler tracks which are employed for equipment mobility.

Materials are removed with this equipment when the open clamshell bucket is placed in the desired site and then closed. This action collects a volume of material which may then be placed in a desired location. This process is repeated until completion of the designed activity. Removal rates of this equipment are limited by the moisture content of the site and the size of the clamshell bucket. A unit schematic is presented in Figure A-1.
- (d) Potential forces and conditions of ignition:
 - Thermal: Material in contact with hot surfaces of equipment.
 - Impact: Excavation bucket contacting material.
 - Electrostatic: None.
 - Friction: Excavation bucket penetrating material.
 - Confinement: None.
 - Moisture reduction: None.
- (e) Application: The clamshell performs most effectively in dry conditions; however, it can operate in wet conditions when necessary. The clamshell relies on its reach to excavate material. It usually operates adjacent to the excavation site.
- (f) Technique safety modification:
 - Velocity restrictions on bucket movement to reduce the impact force during excavation.
 - Bucket constructed of a nonsparking material (i.e., bronze, beryllium) or lined with nonmetallic compounds to reduce spark generation due to friction.
 - Reinforced operator's cab and/or armored underside for protection against shock, etc. generated by a minor reaction.
 - Remotely operated equipment.

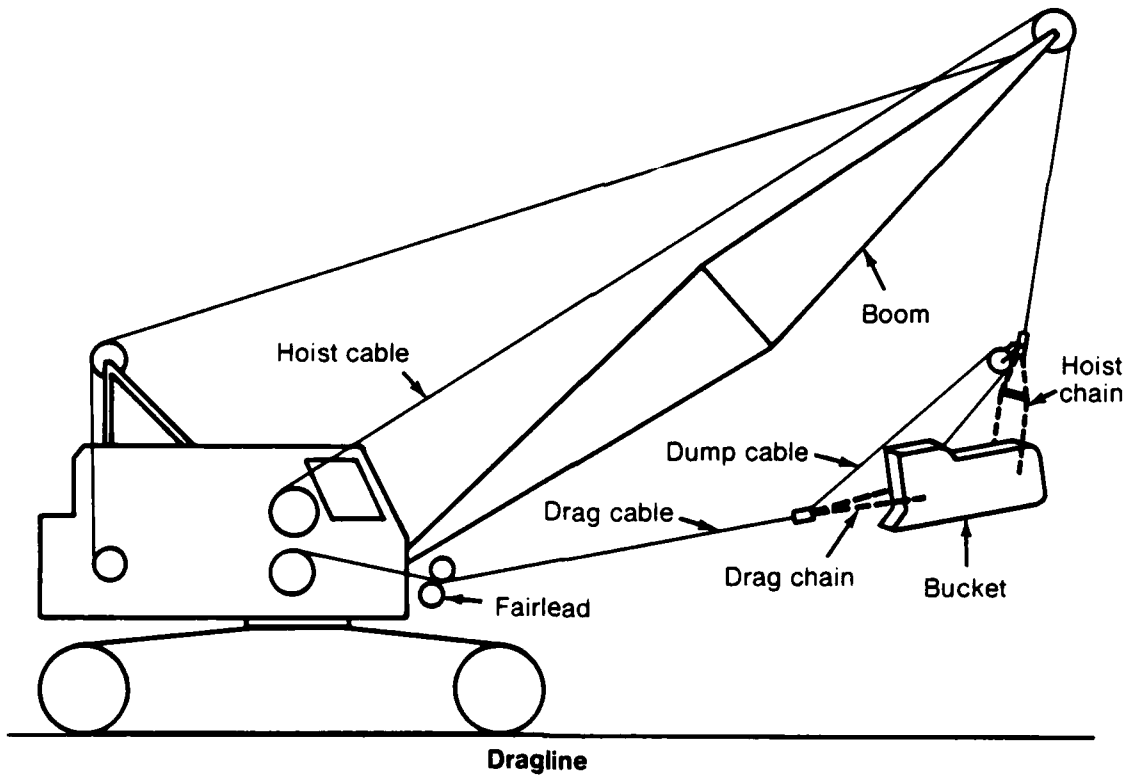
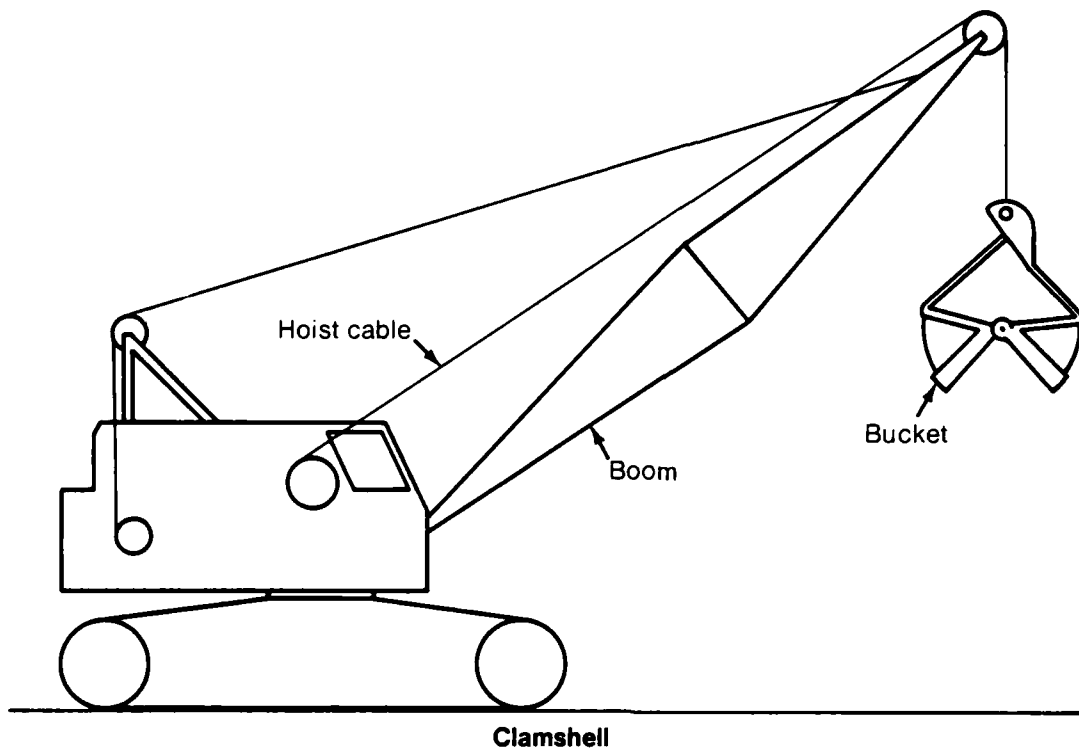

Figure A-1. Equipment schematic of a typical clamshell and dragline.

DRAGLINE

- (a) Materials handling application: Excavation.
- (b) History in explosive materials handling: There has been no documented usage of a dragline for excavation of an explosives contaminated site.
- (c) Description: Dragline excavations are used at sites that require the materials to be moved 20 to 1,000 feet before dumping. Since they are provided with long booms and mounted on turntables, permitting them to rotate through a full circle, these excavators can deposit material directly into containers farther from the point of excavation than any other type of machine. The unit with cab is usually self-contained and mounted on crawler treads. The unit drive system may be powered by gasoline, diesel, or electric systems.

The system is constructed with a boom pivoted on a turntable and supported with cables so that it can be raised or lowered to the desired angle. (See unit schematic presented in Figure A-1.) The excavation bucket is also supported by a cable system. The bucket is dropped and dragged through the designated area until the bucket is filled. After the bucket is filled it is hoisted up and swung to the designated dumping zone where the bucket is emptied.

- (d) Potential forces and conditions of ignition:
 - Thermal: Materials in contact with hot surfaces of equipment.
 - Impact: Excavator bucket contacting material.
 - Electrostatic: None.
 - Friction: Excavator bucket penetrating material.
 - Confinement: None.
 - Moisture reduction: None.
- (e) Application: A dragline performs most effectively in wet conditions; however, it can operate in dry conditions when necessary. The dragline relies on its respective reach to excavate material. This unit usually operates adjacent to the excavation site.
- (f) Technique safety modification:
 - Velocity restrictions on bucket movement to reduce the impact force during excavation.
 - Bucket constructed of a nonsparking material (i.e., bronze, beryllium) or lined with nonmetallic compounds to reduce spark generation due to friction.
 - Reinforced operator's cab and/or armored underside for protection against shock, etc. generated by a minor reaction.
 - Remotely operated equipment.

FRONT-END LOADER

- (a) Materials handling application: Excavation.
- (b) History in explosive materials handling: There has been no documented usage of a front-end loader for excavation of an explosives contaminated site.
- (c) Description: The front-end loader is used for excavation projects in which materials must be placed in a disposal/hauling container at close quarters. The unit, which may be wheel or crawler mounted, has a hydraulically operated bucket mounted to the front end. (See unit schematic illustrated in Figure A-2.)
The excavation process involves picking material up with the bucket and depositing this material at a designed location. Removal rates are limited by site conditions and size of the front-end loader bucket.
- (d) Potential forces and conditions of ignition:
 - Thermal: Materials in contact with hot surfaces of equipment.
 - Impact: Excavator bucket contacting material and movement of this device on a contaminated site.
 - Electrostatic: None.
 - Friction: Excavator bucket penetrating material.
 - Confinement: None.
 - Moisture reduction: None.
- (e) Application: The front-end loader performs most effectively in dry conditions. It must physically operate on a site to effect removal. The operator's location on this equipment is only several feet from the material being handled.
- (f) Technique safety modification:
 - Velocity restrictions on bucket movement to reduce the impact force during excavation.
 - Bucket constructed of a nonsparking material (i.e., bronze, beryllium) or lined with nonmetallic compounds to reduce spark generation due to friction.
 - The movement mechanism can be designed to better distribute the weight of the vehicle, thus reducing the impact force. An example of this type of modification is increasing the width of the crawlers or wheels of the front-end loader.
 - Reinforced operator's cab and/or armored underside for protection against shock, etc. generated by a minor reaction.
 - Remotely operated equipment.

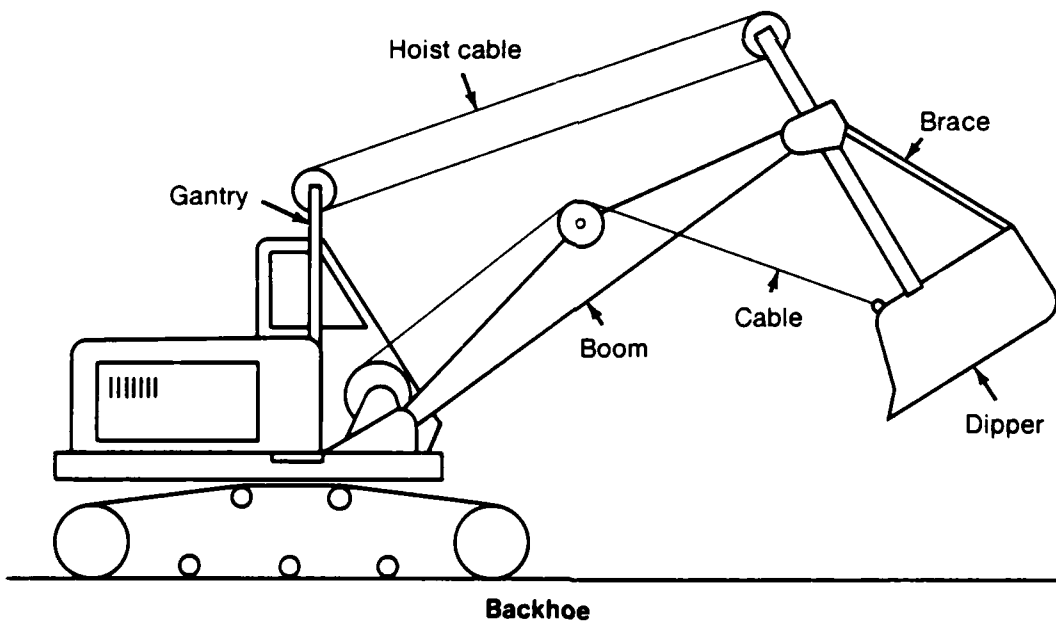
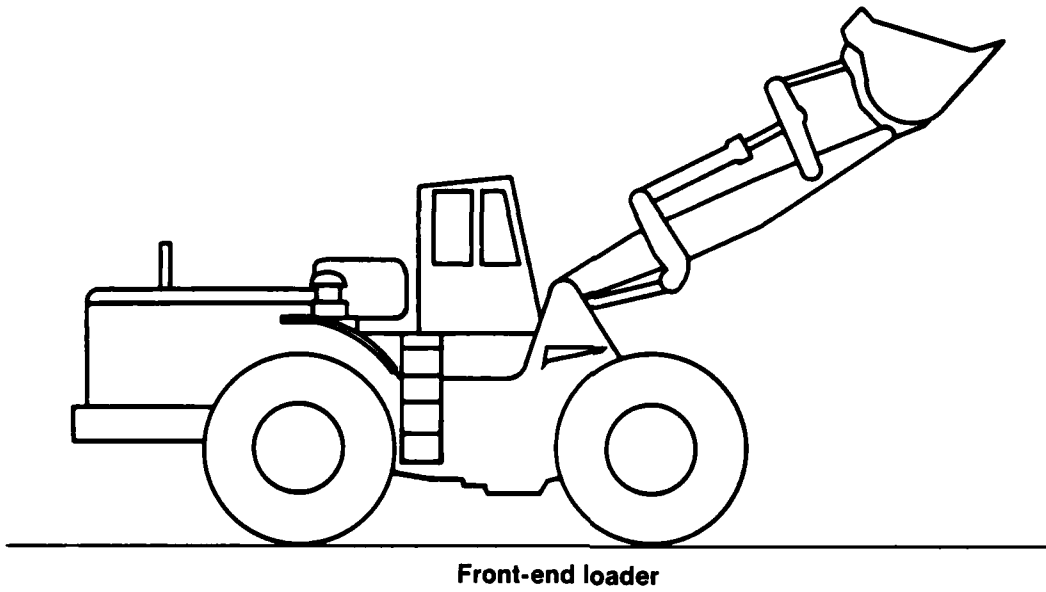

Figure A-2. Typical equipment schematic of a front-end loader and backhoe.

BACKHOE

- (a) Materials handling application: Excavation.
- (b) History in explosive materials handling: There has been no documented usage of a backhoe for excavation of an explosives contaminated site.
- (c) Description: A backhoe is a wheel or crawler mounted excavating device which is equipped with a hydraulically operated arm with attached bucket. The length of the arm is typically designed to extend a maximum of 22 feet while buckets have been sized for 3.5 cubic yards capacity. The operator is seated in a canopy which is located at the base of the mechanical arm on the cab. The cab can sit on a turntable which allows rotation of the unit. (See unit schematic illustrated in Figure A-2.)
- (d) Potential forces and conditions of ignition:
 - Thermal: Materials in contact with hot surfaces of equipment.
 - Impact: Excavator bucket contacting material.
 - Electrostatic: None.
 - Friction: Excavator bucket penetrating material.
 - Confinement: None.
 - Moisture reduction: None.
- (e) Application: The backhoe performs effectively in both wet and dry conditions. The backhoe relies on its reach and mobility to efficiently excavate material. It usually operates adjacent to the area of excavation.
- (f) Technique safety modification:
 - Velocity restrictions on bucket movement to reduce the impact force during excavation.
 - Bucket constructed of a nonsparking material (i.e., bronze, beryllium) or lined with nonmetallic compounds to reduce spark generation due to friction.
 - Reinforced operator's cab and/or armored underside for protection against shock, etc. generated by a minor reaction.
 - Remotely operated equipment.

DREDGING

- (a) Materials handling application: Excavation/transport.
- (b) History in explosive materials handling: There is no documentation of this technology being employed to dredge explosives contaminated solids from contaminated sites.
- (c) Description: Dredging is an excavation and transport operation that involves the pumping of soil/sediment slurries from an underwater environment. The usual type of dredging equipment employs a digging ladder suspended from the bow of a barge at an angle of 45 degrees for the maximum digging depth. This ladder carries the suction pipe and cutter with its driving machinery. The cutter head may have 25 to 1,000 hp applied as the driving force. The usual operating speed of the cutter is 5 to 20 rotations per minute (rpm).

The material excavated by the cutter enters the mouth of the suction pipe, which is located at the lower side of the cutter head. The material is moved via suction by a centrifugal pump which discharges the excavated material at a designated location.

- (d) Potential forces and conditions of ignition:
 - Thermal: None.
 - Impact: None.
 - Electrostatic: None.
 - Friction: Cutter contacting solid material and pumped solids movement in discharge pipes.
 - Confinement: Pumped solids movement in piping.
 - Moisture reduction: None.
 - Multiple source: Poor maintenance allowing solids build-up in operating equipment and piping.
- (e) Application: Dredging is used almost exclusively in river, harbor, and lagoon activities. The technology can only be applied in wet environments. The underwater operation and slurry pumping increase the overall safety by reducing the sensitivity of the contaminated materials.
- (f) Technique safety modifications:
 - Constant recirculation of water in equipment and piping which comes in contact with explosives contaminated soils/sediments to maintain all potentially contaminated particles in suspension.
 - Friction can be reduced in the dredging discharge pipes by minimizing 90-degree bends in the pumping system.

- Friction resulting from the cutter contacting solid material cannot be avoided. It will likely not be a critical source of ignition, since this operation occurs in the presence of water.
- Confinement of material cannot be avoided, but will not likely be a critical source of ignition for the same reason as discussed above.

VACUUM REMOVAL/TRANSPORT

- (a) Materials handling application: Excavation/removal, transport.
- (b) History in explosive materials handling: The vacuum system has not been documented with materials at a contaminated site. Wet vacuum systems are employed, however, for maintenance to remove explosives contaminated dusts at most Army explosives handling facilities.
- (c) Description: The vacuum system may be truck or trailer mounted and may contain additional solid handling equipment.

Figure A-3 illustrates a typical truck mounted vacuum removal system and a diagram of the internal materials handling operations. A vacuum (20 inches of mercury) is established by the rotary blower. Solid particles are pulled into the truck through a suction hose. These solids are then deposited into a container. Any particles carried beyond this area will be collected in a bag filter and may be transported back to the primary solids collection box via a screw-conveyor. In addition, truck mounted systems may contain a centrifugal separator and/or other filter before suction gas is emitted to the atmosphere. The equipment is sized to be able to provide vacuum collection to distances of 1,000 feet.

The same concept may also be employed for short distance transport. A vacuum designed for the given application is applied to a slurry or pulverized solid resulting in the movement of material to a desired location.

- (d) Potential forces and conditions of ignition:
 - Thermal: None.
 - Impact: Solid materials contacting piping and screw conveyor.
 - Electrostatic: Dust explosion in baghouse.
 - Friction: Solid materials contacting piping and screw conveyor.
 - Confinement: Solid material in truck-mounted solid collection box, housing, screw conveyor.
 - Moisture reduction: None.
- (e) Application: The vacuum system may be used to transport material slurries to designated areas. The system may have difficulty removing dry/compacted soils from a contaminated site and may require excavation prior to vacuum removal/transport.

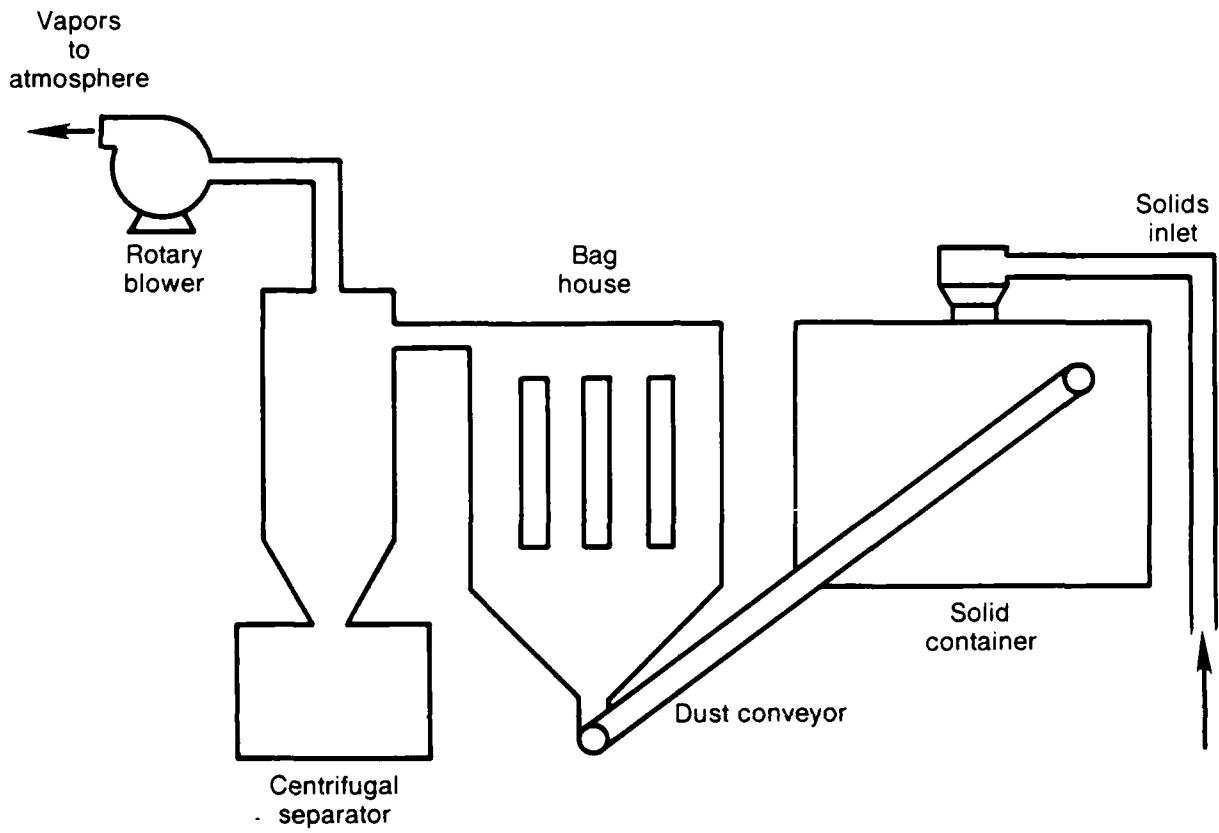

Figure A-3. Typical truck-mounted vacuum removal process schematic.

- (f) Technique safety modifications:
- Precondition material with water.
 - Minimize bends in piping.
 - Use solvent weld piping (avoid screw connections).
 - Induced draft fans in baghouse.
 - Nonsparking materials in baghouse.

RAILROAD CAR TRANSPORT

- (a) Materials handling application: Transport.
- (b) History in explosive materials handling: Railcars have been employed extensively to transport explosive materials and products.
- (c) Description: Solid materials are often transported for longer distances using the railroad system and equipment designed for this purpose. The regulations of the Department of Transportation, the Federal Railroad Administration, and the Association of American Railroads, pertaining to safety devices, safety guards, design of equipment, etc., are mandatory for railroad equipment involved in transporting materials between establishments. The same regulations should be followed for inspection, maintenance, and operation of railroad equipment within an installation (DARCOM-R-385-100). Typical design criteria for rail transport require speed restrictions, specially designed locomotives (i.e., spark arrestors), fire extinguishing equipment, and specific railroad car handling procedures. The design criteria become more stringent as the sensitivity of the cargo increases (49 CFR 174).
- (d) Potential forces and conditions of ignition:
 - Thermal: Heat buildup in railcar.
 - Impact: Force applied during a railcar accident/derailment or force applied by contaminated materials weight in a confined area and during loading and unloading procedures.
 - Electrostatic: Dust explosion in railcar.
 - Friction: Force applied during a railcar accident/derailment.
 - Confinement: None.
 - Moisture reduction: None.
- (e) Application:
 - Explosive materials transported by rail must be containerized and properly braced according to the Bureau of Explosives Pamphlet No. 6C (49 CFR 174, Subpart E).
 - Rail cars are used to transport sensitive explosive materials (both inter and intra plant transport).
 - A well operated rail car transport system requires a rail car feed/emptying system.
- (f) Technique safety modification:
 - Forced ventilation system for each rail car (i.e., draft fan), which aids in temperature and dust control.
 - Additional safety placarding or color coding to immediately identify the rail cars' cargo.
 - Load restrictions in each car to minimize soil/sediment confinement.

VEHICULAR TRANSPORT

- (a) Materials handling application: Transport.
- (b) History in explosive materials handling: Employed at Army explosive handling facilities for inter- and intra-facility transport of explosives materials.
- (c) Description: Sensitive materials are often transported using vehicles designed for this purpose. Design criteria for vehicular transport of explosives include: a modified exhaust system that avoids the ignition of the sensitive cargo, the wiring system located to avoid contact with the sensitive cargo, and all exposed ferrous metal covered with nonsparking to avoid ignition when in contact with the cargo. Solid materials are either loaded in bulk or containerized and loaded onto those vehicles using approved lifting equipment. Once loaded, the vehicle may proceed to the desired location. Upon arrival, cargo is unloaded in a safe manner.
- (d) Potential forces and conditions of ignition:
 - Thermal: On-road accident due to collision; potential fire.
 - Impact: On-road accident due to collision.
 - Electrostatic: None.
 - Friction: None.
 - Confinement: Solid material in transport container.
 - Moisture reduction: None.
- (e) Applications:
 - Vehicles which adhere to DOT regulations have transported boxed TNT on commercial highways.
 - Vehicles have been used for interplant transport of explosives.
 - Based on past experience, explosives contaminated soils/sediments have been classified as flammable solids when transported on commercial highways.
 - Cargo-type trucks and truck-tractor drawn semi-trailers are the preferred vehicles for transporting explosives contaminated soils/sediments. Flat-bed semi-trailers or trailers may also be used to transport large items containerized for such movement.
- (f) Technique safety modifications:
 - Cooling system for cargo area (closed vehicles only) of vehicle transporting sensitive material to avoid any ignitions due to thermal degradation.
 - Weight restrictions for sensitive materials, which reduces confinement conditions within the transport vehicle.

MECHANICAL SCREENING

- (a) Materials handling application: Conditioning or storage.
- (b) History in explosive materials handling: Bulk explosives, in granular or flaked form intended for subsequent processing are required to pass through a screen to remove extraneous material prior to use (as stated in DOD Contractors Safety Manual).
- (c) Description: Coarse screens, commonly known as bar screens, are installed in solids handling systems to remove large particles that might damage or clog subsequent equipment. The apparatus consists of a series of parallel bars in the flow channel which are vertical or at an angle of 60 degrees to the horizontal.
 The bars are usually spaced at 3/4 to 3 inches. The determination of the spacing is based on the influent solid material and the desired particle size distribution requirements of subsequent equipment.
 Large solids which accumulate on the bars are removed by a toothed rake. The rakes are connected to either chains or cables and are operated automatically on a timing basis. The timing of the rakes is based on the amount of debris contained by the solid feed material. The oversized debris, which is removed by the rakes, can be collected for further processing.
- (d) Potential forces and conditions of ignition:
 - Thermal: None.
 - Impact: Material striking contact bar screen.
 - Electrostatic: None.
 - Friction: Rake mechanism in contact with material.
 - Confinement: None.
 - Moisture reduction: Potential exists.
- (e) Applications:
 - Bar screens require a feed and effluent transport system.
 - System can process both dry and slurried soils/sediments based on varied industrial applications.
- (f) Technique safety modifications:
 - Nonsparking metal construction to reduce spark generation due to friction.
 - Water deluge system for apparatus.

CONTAINERIZATION

- (a) Materials handling application: Conditioning or storage.
- (b) History in explosive materials handling: Containers have been used to package and ship explosive materials to and from Army and industrial facilities.
- (c) Description: Containerization technology can provide safe and efficient means of transporting soils/sediments. The container construction materials will vary depending on the application. Containers may be filled using a predetermined mechanical arrangement or automatically via a storage bin equipped with a feeder. Containers are easily stored and stacked, and provide an enclosure for the materials being transported.
- (d) Potential forces and conditions of ignition:
 - Thermal: Container exposed to excessive heat.
 - Impact: Filling of a container; uncontrolled movement of a container.
 - Electrostatic: Dust conditions in container (dry materials only).
 - Friction: None.
 - Confinement: Compaction of materials.
 - Moisture reduction: Potential exists.
- (e) Applications:
 - Re-usable or disposable containers may be used at excavation sites where excavated explosives contaminated soils/sediments are deposited into a container on-site and then transported to a treatment facility.
 - Containers may be shipped by rail or auto if all (DOT) regulatory requirements are met.
 - The APE-1236 explosives waste incinerator is fed directly with open pan containers. This unit operation was observed at Toelle Army Depot.
- (f) Technique safety modifications:
 - Add water where appropriate (at least 10 percent by weight) to all containers to decrease the sensitivity of the contaminated soils/sediment. Container strength must not decrease with addition of water.
 - Water deluge system near container filling system to reduce fire and explosive hazards.
 - Weight restrictions for soils/sediments within a container to reduce confinement conditions.

MECHANICAL DEWATERING: CENTRIFUGE

- (a) Materials handling application: Conditioning or storage.
- (b) History in explosive materials handling: There has been no documented usage of a centrifuge for dewatering explosive material. A flaker which uses a rotating basket with cooling is employed at Radford AAP to flake crude TNT. This unit is constructed of carbon steel with a copper/beryllium knife which is used to remove the flaked product from the unit.
- (c) Description: Centrifugation is a materials-conditioning process which involves liquid-solid separation utilizing centrifugal force either for thickening or dewatering of solids from slurries.
Centrifuges may operate on a settling principle in which the denser phase is brought to the outside by the centrifugal force, or on a filtration principle, as in a basket centrifuge, where the mesh of the basket retains solid particles and the centrifugal force causes the liquid to flow through the solids in the basket more readily than in an ordinary filter.
Solids may be removed on a continuous or batch basis depending on centrifuge design. Moisture content of the resultant solids is controlled by the properties of the solid, the rotational velocity of the basket, and the detention time in the unit.
- (d) Potential forces and conditions of ignition:
 - Thermal: Material contacting hot surfaces.
 - Impact: None.
 - Electrostatic: Rotating parts resulting in accumulation of charged particles.
 - Friction: Material contacting moving parts; solid material contacting stationary knives during removal from basket.
 - Confinement: None.
 - Moisture reduction: Potential exists.
- (e) Applications:
 - A centrifuge will separate water from explosives contaminated soils/sediments.
 - A properly designed solid collection area must be utilized with the centrifuge.
- (f) Technique safety modifications:
 - Selection of proper construction materials for parts in contact with soil/sediment to minimize frictional forces.
 - Centrifuge must be well grounded to prevent build-up of electrostatic charge.
 - Centrifugal velocity restrictions on centrifuge to reduce applied forces during slurry handling.

DELUMPER

- (a) Materials handling application: Conditioning or storage.
- (b) History in explosive materials handling: Product TNT is passed through a delumper at Radford AAP. The unit's capacity is 250 lb/hr (2 ft diameter unit) with stainless steel knives as the delumping apparatus. The unit has operated for 7 years without incident.
- (c) Description: Delumping is a particle size reduction technique which produces a uniform solid material from an irregular feed via mechanical processing. This unit consists of a cylindrical shell with a rotating shaft positioned on the center line of the cylinder. Knives (or spikes) are positioned on the entire length of the shaft at predetermined spacing. The length of these knives approaches the inner wall of the cylinder. The rotating action of the knives breaks-up large sized particles contained in the feed material. The effluent from this apparatus contains a solid flow with uniform particle size distribution.
- (d) Potential forces and conditions of ignition:
 - Thermal: None.
 - Impact: Delumping mechanism contacting material.
 - Electrostatic: Dust particles susceptible to electrostatic ignition.
 - Friction: Material contacting outer wall of mechanism.
 - Confinement: None.
 - Moisture reduction: Potential exists.
- (e) Applications:
 - This unit can process both dry and slurry feeds.
- (f) Technique safety modifications:
 - Nonsparking construction materials for knives to reduce spark generation due to friction.
 - Water deluge system in apparatus to control unwanted reactions.
 - Dust control system to reduce dust explosion potential.
 - Construction of barriers around apparatus to protect personnel and equipment.

WET GRINDING

- (a) Materials handling application: Conditioning or storage.
- (b) History in explosive materials handling: Technique employed at Radford AAP for demilitarization of explosives. Materials are wet grinded prior to incineration.
- (c) Description: Wet grinding is a particle size reduction technique which produces a uniform solid material from a nonuniform particle size feed via mechanical processing.
This process usually occurs in a cylindrical or conical shell rotating on a horizontal axis. The unit is charged with grinding medium such as steel or porcelain balls or steel rods. The smaller the grinding medium, the finer the output product. The solid material along with a predetermined volume of water is fed into the rotating mill. Size reduction is effected by the tumbling of the grinding medium on solid feed material.
- (d) Potential forces and conditions of ignition:
 - Thermal: None.
 - Impact: Material contacting grinding material.
 - Electrostatic: None.
 - Friction: Material contacting grinding material.
 - Confinement: None.
 - Moisture reduction: None.
- (e) Applications:
 - This operation can be run without moisture addition, but sensitivity to an unwanted reaction increases.
- (f) Technique safety modifications:
 - Nonsparking construction material for grinding medium to reduce spark generation due to friction.
 - Water deluge system in apparatus to control unwanted reactions.
 - Dust control system to reduce dust explosion potential.
 - Construction of barriers around apparatus to protect personnel and equipment.

STORAGE VESSEL (WITH SOLID REMOVAL MECHANISM)

- (a) Materials handling application: Conditioning or storage.
- (b) History in explosive materials handling: Employed for short-term storage of solid explosives product prior to final packaging.
- (c) Description: Storage vessels contain solid material just after or prior to removal, transport, or treatment process. The physical properties of a solid material dictate the design of a storage vessel (size, shape, height-to-diameter ratio). Properties such as particle size, moisture content, and temperature control solid material flow properties/patterns in a confined situation. Larger particle sizes, lower moisture content, and lower temperatures contribute to improved flow of solid materials in a storage vessel.
Any successfully operating storage bin must have a well designed feed and outlet flow system. These units are considered part of the overall vessel operation. Typical devices used for outlet flow control of solids are air activated live bottom bins or rotary valve with a typical solid material conveyance system.
- (d) Potential forces and conditions of ignition:
 - Thermal: Vessel in contact with excessive heat.
 - Impact: None.
 - Electrostatic: Dust conditions in storage vessel.
 - Friction: Removal mechanism contacting material.
 - Confinement: Compaction of material within vessel.
 - Moisture reduction: Potential exists.
- (e) Applications:
 - Storage vessels can isolate contaminated soils from the environment once these soils have been removed from a designated site. Storage piles would require runoff control along with dust control.
- (f) Technique safety modifications:
 - Dust control system to reduce dust explosion potential.
 - Water deluge system to control any unwanted reaction.
 - Nonsparking materials of construction to reduce the potential for spark generation due to friction.
 - Limit the force per unit area applied to soils/sediments on itself by limiting the amount of material in each vessel.

MAGAZINE STORAGE

- (a) Materials handling application: Conditioning or storage.
- (b) History in explosive materials handling: Employed by Army and industrial manufacturers for both long-term and short-term storage of explosive materials.
- (c) Description: Earth-covered (igloo or other subsurface) magazines are the most common method employed for bulk explosive and propellant storage. This design offers the greatest protection to explosives and affords the greatest degree of protection from the results of an explosion. Storage requirements, including storage compatibility grouping, are based on magazine construction and location, effects of explosion on stored items, rate of product deterioration, sensitivity to initiation, type of packing, effects of fire, and quantity of explosives per unit. Each magazine is designed with specific controls to monitor the environment inside the unit. There are also specific safety regulations concerning the location of differing explosives within a magazine and access to the magazines. These regulations are detailed in DARCOM-R-385-100, Section 18.
- (d) Potential forces and conditions of ignition:
 - Thermal: Poor temperature control.
 - Impact: Packaged materials striking floor as a result of poor handling practices or an accident.
 - Electrostatic: Dust explosion.
 - Friction: None.
 - Confinement: Compaction of material within magazine.
 - Moisture reduction: Potential exists.
- (e) Applications:
 - Magazines will isolate explosives contaminated soils from the environment, thus avoiding spread of contamination via particulates in the atmosphere or run-off into surface water.
- (f) Technique safety modifications:
 - Dust control system to reduce dust explosion potential.
 - Temperature alarm system for each magazine to monitor any temperature rise.
 - Develop safety program to include manual safety inspections to reduce the potential for accidents.

SLURRY PUMP/HYDRAULIC CONVEYOR

- (a) Materials handling application: Transport, treatment, and disposal feed.
- (b) History in explosive materials handling: Radford AAP employs a waste incinerator which accepts a waste explosive/water slurry (3 parts water; 1 part explosive). Crude explosives handling involves slurry transport prior to solidification.
- (c) Description: A slurry pumping/hydraulic conveyance technology is successfully implemented by mixing a liquid with a solid in designated proportions to produce a slurry that can be pumped. Once slurried, the mixture can be pumped to the designated processing area.

Slurries may be pumped either small distances or distances over 1,000 miles. Pumping efficiency is directly effected by solid particle size and concentration in the slurry. The selection of pumping equipment is dependent on the previously mentioned slurry properties.

A slight variation of this technique is hydrosluicing. This technique employs a soil/water slurry transferred by gravity via a sluice (open flume) and can be applied in conjunction with slurry pumping. The motive force for slurry conveyance is the static head designed into the system. This head must maintain a velocity to prevent the solid particles from settling in the chute.

- (d) Potential forces and conditions of ignition:
 - Thermal: Materials contacting hot mechanical parts of the pump.
 - Impact: None.
 - Electrostatic: None.
 - Friction: Material contacting pipe walls.
 - Confinement: Material accumulating in piping system.
 - Moisture reduction: Potential exists during service interruptions.
- (e) Applications:
 - Soils/sediments may be slurried with a flammable liquid before a thermal degradation treatment technology is applied.
 - The coal industry has transported coal slurries over 1,000 miles.
 - System may require additional materials handling equipment to effect a soil slurry system.
- (f) Techniques safety modifications:
 - Pressurized seals with water flush to minimize the potential of soil/sediment contacting heated mechanical pumping parts.
 - Automatic line flushing during off-line conditions.
 - Piping to be flanged for safe access during maintenance procedures.

BELT CONVEYORS

- (a) Materials handling application: Treatment or disposal feed.
- (b) History in explosive materials handling: The belt conveyor is commonly used to transport bulk solid explosives in a manufacturing or a load and pack facility.
- (c) Description: The belt conveyor is a heavy-duty unit available for transporting large tonnages over paths beyond the range of other types of mechanical conveyors. The capacity may be several thousand tons per hour, and distances of up to several miles. The unit may be horizontal or may have upward or downward inclines. The limit of incline is attained when the solid material slips on the belt (for soil/sediments, the maximum slope is approximately 20 degrees at moisture contents of 15 to 30 percent).

The unit's operation is fairly simple as a motor provides energy necessary to move the belt at loaded conditions. Carry and return idlers (Figure A-4) are employed at specified distances to keep the conveyor belt properly aligned. The spacing of the carry idlers varies with the width and loading of the belts and is usually 5 feet or less. Return idlers are spaced on 10 foot centers (or slightly less with wide belts). Sealed antifriction idler bearings are used almost exclusively.

The sizing of a unit depends on distance traveled and quantity of solid material to be removed. The belt selection is directly influenced by the nature and chemical activity of the solid to be transported.

- (d) Potential forces and conditions of ignition:
 - Thermal: Materials contacting hot surfaces.
 - Impact: None.
 - Electrostatic: Charge build-up due to belt movement.
 - Friction: Movement of belts against side walls or idlers.
 - Confinement: None.
 - Moisture reduction: Potential exists.
- (e) Applications:
 - A belt conveyor can be used to transport explosive materials to a treatment unit and may be employed to feed a treatment unit operation.
 - Materials to be handled may contain moisture. Increasing moisture will tend to create difficulties in conveyor feed and discharge systems.

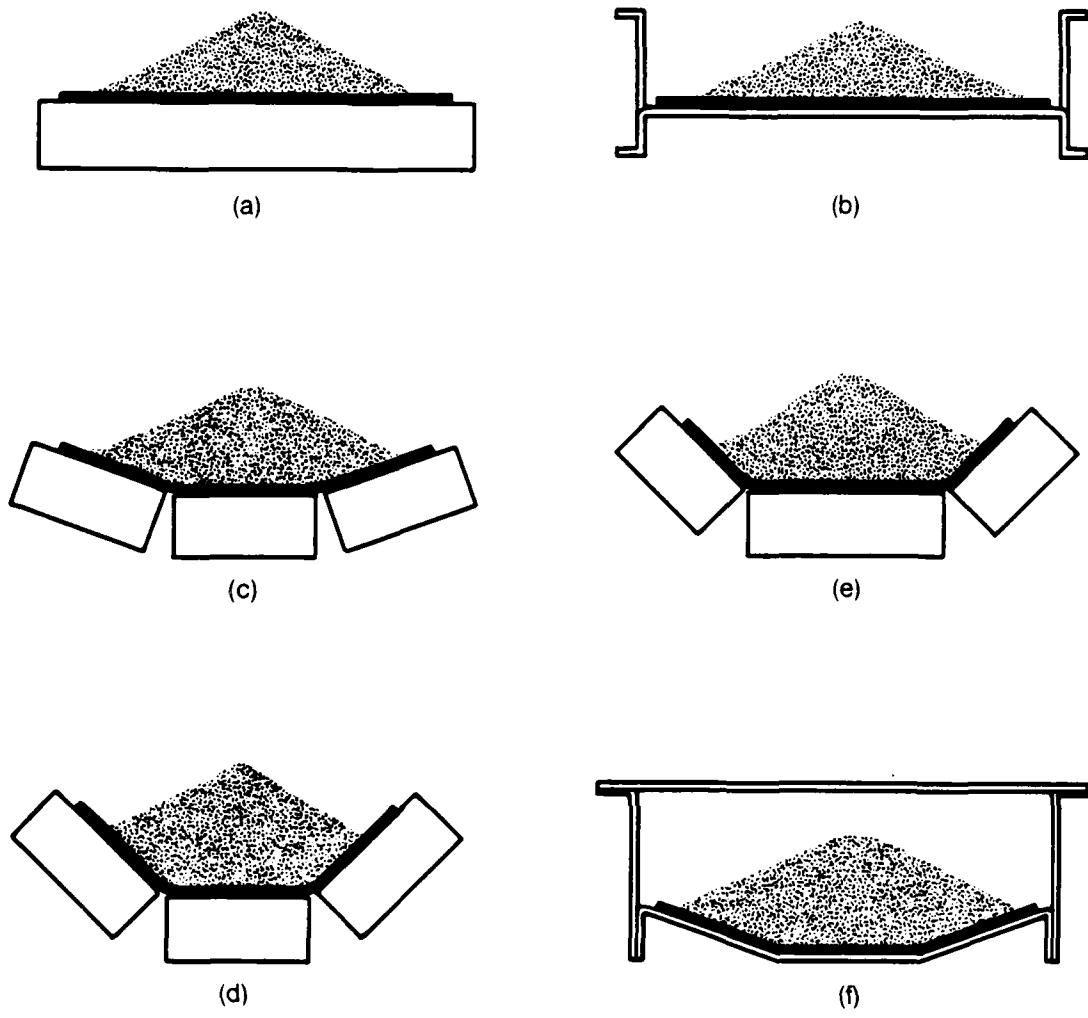

Figure A-4. Typical belt conveyor idler and plate support arrangements.
 (a) Flat belt on flat belt idler. (b) Flat belt on continuous plate.
 (c) Troughed belt on 20 degree idlers. (d) Troughed belt on 45 degree idlers with rolls of unequal length. (e) Troughed belt on 45 degree idlers with rolls of equal length. (f) Troughed belts on continuous plate.

(f) Techniques safety modifications:

- Sealed bearings are a recommended standard feature for this application.
- System should contain a water deluge system to reduce unwanted reactions.
- Containment walls of conveyor to be constructed of spark-resistant material to reduce spark generation due to friction.
- Conductive belts to minimize static electricity.

SCREW CONVEYOR

- (a) Materials handling application: Treatment or disposal feed.
- (b) History in explosive materials handling: A screw conveyor has been employed as part of an incineration feed system at Radford AAP. The screw is constructed of stainless steel, has a diameter of 4 inches, and operates at a speed of 0.5 feet per second.
- (c) Description: The screw or spiral conveyor (Figure A-5) is regularly employed for transport of nonuniform solid material. Typical screw conveyors are limited to 10,000 cubic feet per hour (approximately 250 tons per hour) capacity, distances no greater than 200 feet, and inclines no greater than 35 degrees. The unit consists of helicord (helix rolled from flat steel) or sectional (helix cut from steel) flight, mounted on a pipe or shaft and turning in a trough. This turning action along with the shape of the screw will act as the motive force for the transport operation.

There are several screw design patterns available for use in a screw feeder. The selection depends on the material to be conveyed. Actual capacities of screw conveyors are determined by material particle size, screw diameter and rotations per minute of the actual screws.

This unit can be completely sealed from the environment at positive or negative pressure, and the casing can be insulated to maintain internal temperatures in areas of high and low ambient temperature.

- (d) Potential forces and conditions of ignition:
 - Thermal: Materials contacting hot surfaces.
 - Impact: None.
 - Electrostatic: None.
 - Friction: Material in contact with conveyor walls; contact of screw with conveyor walls due to deflection of screw.
 - Confinement: Potential exists based on normal operating procedures.
 - Moisture reduction: Potential exists.
- (e) Applications:
 - A screw conveyor can be employed as a short distance transport or treatment feed mechanism.
 - A screw conveyor must be accompanied by a feed unit and a designated discharge location.

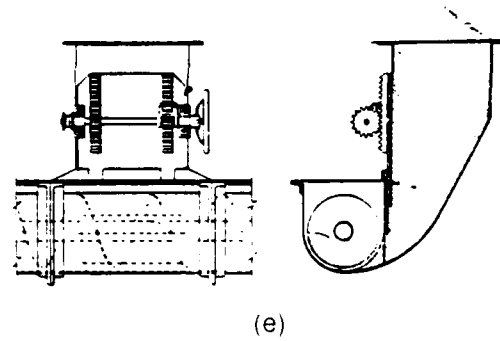
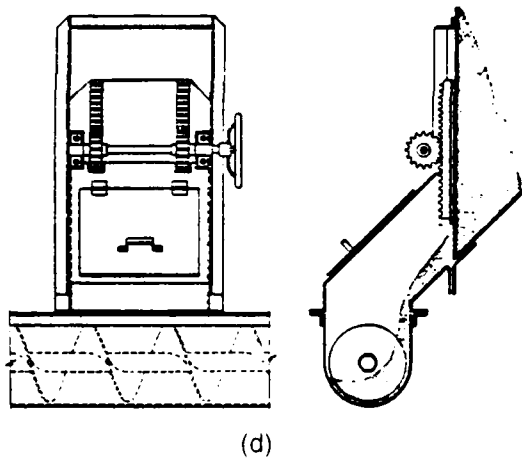
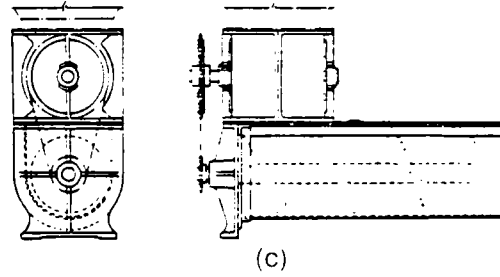
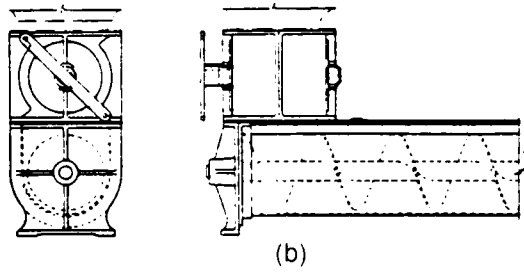
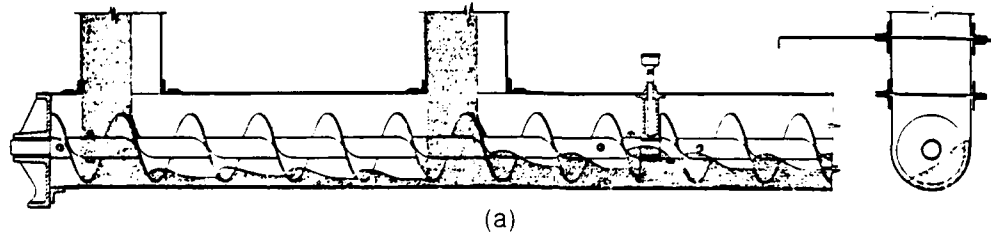

Figure A-5. Typical mechanical feed and transport arrangements for screw conveyors. (a) Plain spouts or chutes. (b) Rotary cutoff valve. (c) Rotary vane feeder. (d) Bingate. (e) Side inlet gate.

- (f) Techniques safety modifications:
- Unit should shut down when a high torque level is reported.
 - Vary size of screw threads (small to large) to minimize screw deflection and identify when deflection occurs. This identification will be defined based on higher torque levels.

BUCKET CONVEYORS

- (a) Materials handling application: Treatment or disposal feed.
- (b) History in explosive materials handling: A modified hand-loaded bucket conveyor system was used to feed explosive material into a pilot incineration unit at Savanna, Illinois.
- (c) Description: Bucket conveyors are employed to vertically elevate any solid materials that will not adhere to the bucket (Figure A-6). There are two types of bucket conveyors: 1) chain-and-bucket, where the buckets are attached to one or two chains and 2) belt-and-bucket, where the buckets are attached to canvas or rubber belts.

Belt-and-bucket elevators are well adapted to handling abrasive materials which would produce excessive wear on chains. Chain-and-bucket elevators are frequently used with perforated buckets when handling wet material to drain surplus liquid.

The length of elevators is limited by the strength of the chains or belts. They may be built up to 100 feet long and operate best on an angle of about 30 degrees to vertical (at smaller angles, the sag of the return belt is excessive).

This conveyor system must have a well designed feed and discharge mechanism to perform at peak efficiency. The pivoted buckets are fed and elevated to the discharge point. At this location, the buckets are tipped to discharge the solid material. Once empty, the buckets are returned to the feed area for another load. Spacing and velocity of the conveyor are predetermined design parameters.
- (d) Potential forces and conditions of ignition:
 - Thermal: Materials contacting hot surfaces.
 - Impact: Forces applied during load and unloading of material.
 - Electrostatic: Charge accumulation due to drive belt movement.
 - Friction: None.
 - Confinement: None.
 - Moisture reduction: None.
- (e) Applications:
 - This unit can be adapted to transport soils or act as a feed to a treatment unit process.
 - Clay soils with moisture content greater than 10 percent are likely to stick to the bucket container, which may create handling difficulties.
 - System must have feed discharge systems which may utilize other materials handling technologies.

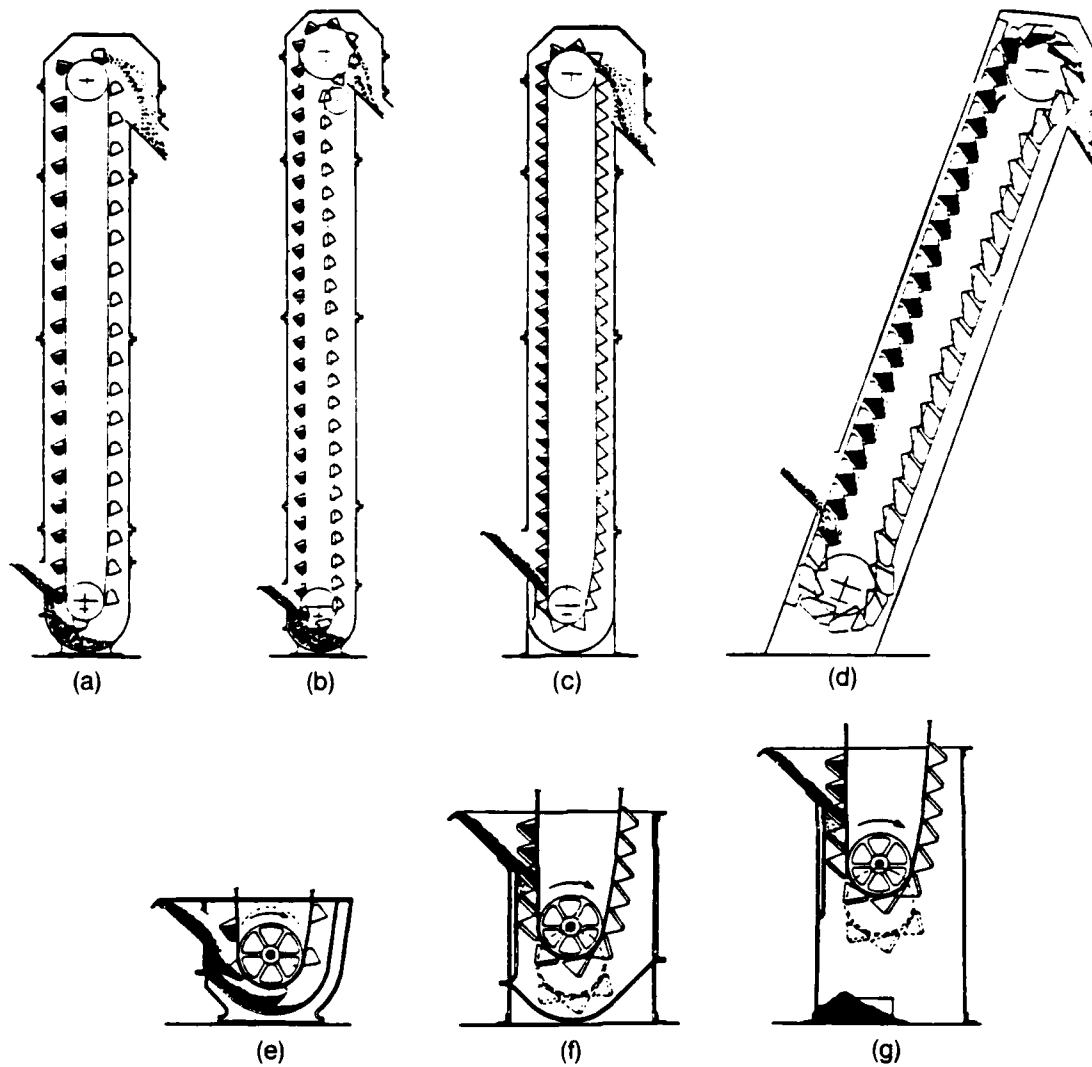

Figure A-6. Typical bucket elevators and feed mechanisms.
 (a) Centrifugal discharge, spaced buckets. (b) Positive discharge, spaced buckets. (c) Continuous bucket. (d) Supercapacity continuous bucket. (e) Spaced buckets receive part of a load directly and part by scooping from the bottom. (f) Continuous buckets are filled as they pass through loading let, with feed spout above tail wheel. (g) Continuous: buckets in bottomless boot with cleanout door.

(f) Techniques safety modifications:

- Enclosed system with water deluge system to prevent unwanted reactions.
- All bearings to be sealed.
- Use of conductive belts when possible.
- Employ spark-resistant materials of construction for mechanical parts that contact soils/sediments.

VIBRATORY CONVEYOR/FEED SYSTEM

- (a) Materials handling application: Treatment or disposal feed.
- (b) History in explosive materials handling: Vibratory conveyor and feeder systems are employed at Radford AAP for materials handling of explosive materials.
- (c) Description: Vibratory systems move solid materials by applying an oscillating force to a solid object. This force creates a vibration action which moves solid particles in a desired direction.
Vibratory conveyors (Figure A-7) are directional-throw units which consist of a spring-supported horizontal pan vibrated by a direct-connected arm. The motion imparted by this system will throw the material upward and forward so that it will travel along the conveyor path in a series of short hops. The capacity of a directional-throw vibrating conveyor is determined by the magnitude of trough displacement, frequency of this displacement, angle of throw, slope of trough, and the physical properties of the solid being handled. The units may also be employed to dry solids and separate solid particles.
Vibratory forces may also be applied to storage bins to aid in the movement of solid from the bin to a transport mechanism (live bottom). A drive assembly with adjustable eccentric weights is attached to the bottom of a storage vessel. When actuated, a vibratory force is applied to the solid material, but is not transmitted to the storage vessel.
- (d) Potential forces and conditions of ignition:
 - Thermal: Materials contacting hot surfaces.
 - Impact: None.
 - Electrostatic: Charge accumulation resulting from conveyor movement.
 - Friction: Contact between explosive materials and conveyor walls or other mechanical parts.
 - Confinement: None.
 - Moisture reduction: None.
- (e) Applications:
 - Material to be conveyed should have a high friction factor on steel, as well as a high internal friction factor so that the conveying action is transmitted through its entire length.
 - Soils with high moisture content (sludge like consistency) can not be transported using this system.
 - Nonuniform soil particles may be broken-up and nonsoil particles can be separated using this system.
 - This system is not applicable to thixotropic materials such as clays.

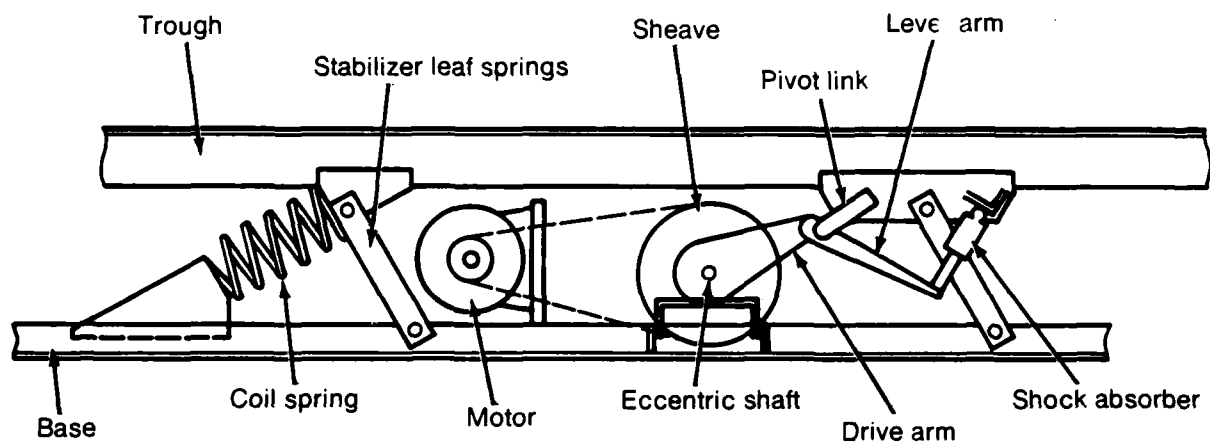

Figure A-7. Mechanical schematic of a typical vibratory conveyor.

- (f) Techniques safety modifications:
- Water deluge system to prevent unwanted reactions.
 - Protective barriers and cover to protect personnel and equipment.
 - Temperature monitoring at designated sensitive areas.
 - Electrostatic source reduction.

PNEUMATIC CONVEYOR

- (a) Materials handling application: Treatment or disposal feed.
- (b) History in explosive materials handling: Pneumatic systems for transporting flaked TNT have been installed at Army facilities for intra-plant transport.
- (c) Description: The pneumatic conveyor transports dry, free-flowing granular material in suspension within a pipe or duct by means of a high-velocity airstream or by the energy of expanding compressed air within a comparatively dense column of fluidized or aerated material. Solid particles ranging from fine powders to 1/4-inch pellets and bulk densities up to 200 pounds per cubic foot can be transported to distances up to 1,000 feet. The design capacity of a pneumatic system is limited by the product bulk density, particle size, and energy content of the conveying air over the entire distance.

Air velocities which are used as the driving force in this system are established via a positive pressure or vacuum system. In a pressure system, material is fed into an air stream (at positive pressure) by a rotary air-lock feeder. The particles are suspended until they reach a receiving vessel where they are separated from the air by means of an air filter or cyclone separator.

A vacuum pneumatic conveyor achieves required air velocities by applying negative pressure to a material storage vessel. (A rotary feeder is not necessary with this system.) Material remains suspended in air until it reaches a receiver where air is separated via a filter or cyclone separator.

- (d) Potential forces and conditions of ignition:
 - Thermal: None.
 - Impact: Contact of explosive materials against pipe walls.
 - Electrostatic: Accumulation of charged particles during materials transport.
 - Friction: Contact of explosive materials against pipe walls.
 - Confinement: Materials in transport piping.
 - Moisture reduction: Potential exists.

- (e) Applications:
 - Soils/sediments from contaminated sites would probably need to be air dried and undergo particle size reduction in order to be conveyed pneumatically.
- (f) Techniques safety modifications:
 - Minimize piping bends; use long sweep elbows and bends.
 - Use spark-resistant materials of construction for piping that contacts soils being conveyed.

MANUAL FEED

- (a) Materials handling application: Treatment or disposal feed.
- (b) History in explosive materials handling: Containers of off-spec explosives are manually filled prior to disposal in APE-1236 explosives waste incinerator at Army facilities. Buckets containing explosives materials were manually filled prior to incineration pilot testing conducted at Savanna, Illinois.
- (c) Description: A manual feed employs laborers who directly feed solid material to a treatment process, or containers to be used in transportation or a treatment process. This operation may be completed with the use of mechanical devices to move manually filled containers to a desired location.
- (d) Potential forces and conditions of ignition:
 - Thermal: None.
 - Impact: Mishandling of explosive material.
 - Electrostatic: None.
 - Friction: Contact between explosive material and manually-operated tools and equipment.
 - Confinement: None.
 - Moisture reduction: None.
- (e) Applications:
 - Manual feed systems increase potential of human injury during an unexpected incident.
 - Feed capacity for this technique is limited by human constraints.
- (f) Techniques safety modifications:
 - Protective barriers.
 - Isolation of soil/sediment handling area.
 - Water deluge system in manual feed area.
 - Addition of moisture to soils/sediments being handled.
 - Nonsparking equipment to reduce spark generation due to friction.

RAM FEED SYSTEM

- (a) Materials handling application: Treatment or disposal feed.
- (b) History in explosive materials handling: Army facility waste explosive incinerators employ a ram system to feed open pan containers into the incinerator.
- (c) Description: The ram feed system relies on a mechanically driven piston which flexes back and forth in a chamber. Solid material (either loose or containerized) is conveyed to the ram feed area in a designated fashion. Once this material is correctly positioned, the ram feeder is activated. The ram pushes the solid into a desired chamber. Upon completion of this cycle, the ram returns to its original position in preparation for the next load.
- (d) Potential forces and conditions of ignition:
 - Thermal: Explosive material contacting hot surfaces.
 - Impact: Ram feeder contacting explosive material.
 - Electrostatic: None.
 - Friction: Explosive material contacting system walls.
 - Confinement: Material in the ram feed system.
 - Moisture reduction: None.
- (e) Applications:
 - This system's sensitivity is directly related to treatment system. For example, thermal treatment processes that have ram feeders must be designed to prevent propagation back to the feed material transport mechanism.
 - Wet solids would be difficult to handle unless containerized prior to feed.
- (f) Techniques safety modifications:
 - Barriers between feed system and operating personnel.
 - Materials of construction which reduce friction between feed material and feed system.

GRAVITY FEED VIA CHUTES

- (a) Materials handling application: Treatment or disposal feed.
- (b) History in explosive materials handling: Gravity feed via chutes are employed at Army and industrial manufacturing facilities to handle solid explosives product.
- (c) Description: Solid or liquid material may be deposited into a treatment unit via a chute. A chute is a pathway in which material is passed to get to a final destination. The motive force is the static head from point of discharge to receiving point. The cross-sectional area of a chute must be designed to minimize frictional input to the material which is passing through.

The vertical chute is primarily employed for solids handling, but other designs have been employed to minimize damage to fragile solids. Chutes can be designed on angles to slow the velocity of the material as it passes. For example, coal chutes are usually designed on a 45° angle. Other types of chutes employed to reduce velocity, but maintain a forward flow due to gravity, are the ladder chute, box chute, and spiral chute.
- (d) Potential forces and conditions of ignition:
 - Thermal: Explosive material contacting hot surfaces.
 - Impact: Acceleration of particles in chute contacting other material in receiving area.
 - Electrostatic: None.
 - Friction: Material contacting chute walls during handling.
 - Confinement: Poor maintenance resulting in blockage within chute.
- (e) Applications:
 - Chutes are typically employed in any coal handling unit.
 - Clay soils may tend to plug in a chute.
 - Sensitive materials are more readily handled on an inclined or flow inhibiting chute.
- (f) Techniques safety modifications:
 - Nonsparking material of construction for chutes to reduce sparking potential due to friction.
 - Air activated flexible connection on chutes to minimize potential of bridging of solids and resultant blockage.

APPENDIX B
SENSITIVITY TEST METHODS

5449A

AD-A162 516

INSTALLATION RESTORATION GENERAL ENVIRONMENTAL
TECHNOLOGY DEVELOPMENT TRS. (U) WESTON (ROY F) INC WEST
CHESTER PA L J BOVE ET AL JUN 85 AMXTH-TE-TR-85018
DAAK11-82-C-0017 F/G 13/2

2/2

UNCLASSIFIED

NL



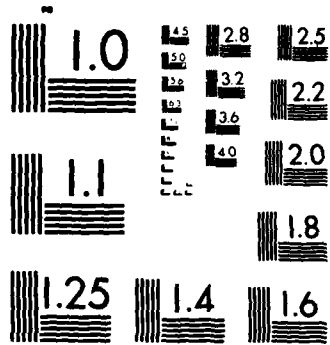

MICROCOPY RESOLUTION TEST CHART
NATIONAL BUREAU OF STANDARDS-1963-A

APPENDIX B

SENSITIVITY TEST METHODS

B.1 Bureau of Mines impact test. Twenty milligrams (0.02 g) of material are placed between two flat parallel hardened steel surfaces. The impact impulse is transmitted to the sample by the upper flat surface.

A 2-kilogram object is released from a specific height (recorded in centimeters) onto the steel plate. Results are either a positive (ignition) or a negative (no ignition). A positive result is evidenced by a flame or audible sound. Smoke alone is not a positive result. The test is usually repeated 10 times at each test height.

Data acquired can be reflected by development of a probability of detonation vs. energy impact curve.

B.2 Bureau of Explosives impact test. Twenty milligrams of material (no stipulated volume for test completion) are placed in the depression of a small steel die-cup, capped by a thin brass cover, in the center of which is placed a slotted-vented-cylindrical steel plug, slotted side down.

A 2-kilogram object is released from a specific height (recorded in inches) onto the sample holding device. Results are either positive (ignition) or negative (no ignition). A positive result is evidenced by a flame or audible sound. Test is repeated 10 times at each test height. One positive result at a specific height indicates a positive result for that drop height.

B.3 No. 8 cap (detonation) test. Use of the No. 8 blasting cap has relevance to the Bureau of Explosives for purposes of explosive classification. This is a standard test which demonstrates behavior of a material to the initiating force produced by the igniting cap. The cap is inserted into the sample, which is placed in a paper cup resting on a lead block, and then detonated. A positive result (ignition) is evidenced by 1/8 inch of greater compression of the lead block. EPA uses the same test for purposes of characterization of a material as a hazardous waste by reason of explosivity.

B.4 Spark test. This test subjects a material to an electric squib for the purpose of determining behavior from this type source. An electric igniter is placed into the sample which is placed into a paper cup resting on a lead block and then detonated. A positive result is evidenced by the burning of the sample and a mushrooming of the lead block as a result of the detonation. The Bureau of Explosives uses this test as part of its explosives classification protocol. EPA requires the test for RCRA characterization. It may be used for purposes of hazardous assessment of mechanical operations.

B.5 Friction test. Sensitivity to friction is a requirement for ignitability under RCRA and has relevance to personnel and mechanical safety. The test, as run in various commercial laboratories, is a nonstandard test since no standard device is used universally. Devices are available, however, for estimating sensitivity to friction/shear produced by a swinging hammer. A positive result is evidenced by the production of flame, smoke, or distinct loud noise. An analysis using infrared detection for specific decomposition products is also a positive result. Typical test variables include total force applied and velocity of swinging hammer.

B.6 Thermal stability test. This standard test subjects a loosely-confined 10-gram sample to a temperature of 167°F for 48 hours and is used by the Bureau of Explosives as part of its explosive classification protocol. EPA requires the same test for RCRA characterization. A positive result is evidenced by any audible pop produced by a detonation or deflagration. Fuming/smoldering of the sample is not a positive result.

B.7 Fire test. A standard test for blasting agents is available for determining the sensitivity of a material to pen flame. A plastic container holding the sample is subjected to a fire. A positive reaction is evidenced by an audible noise and a projection of fragments. This test is relevant to RCRA characterization for ignitability and to safety of personnel and mechanical equipment.

B.8 Cook-off test. Potentially reactive materials are confined and then heated to 167°F for 48 hours. A positive result of this test is evidenced by an audible noise and a projection of fragments. This test has not been authorized by any Federal agency nor has it been proposed as part of a testing protocol by any Federal agency.

B.9 Electrostatic test. The samples are tested under two amounts of confinement, designated as unconfined and confined. In the unconfined test, a sample of approximately 0.05 g is dumped into a shallow depression in a steel block and flattened out with a spatula. In the confined tests (partly confined), the sample of approximately 0.05 g is introduced into soft-glass tube (7 mm ID x 18 mm long) which fits over a metal peg. The volume of the space around the charge at zero gap is 0.15 cm³; at a gap of 0.6 mm, it is 0.4 cm³. In addition to providing moderate confinement, this system also minimizes dispersion of the sample by the test spark, and reduces the effect of material being repelled from the needle point by electrostatic field effect.

When a test is to be made, the needle point electrode is screwed up until the gap between electrodes is greater than the critical gap discharge at the test voltage. The sample is then placed in position, the high-voltage terminal of the charged condenser is switched to the point electrode by means of a mercury switch, and the electrode is screwed down until discharge occurs. The spark energy (in joules), for zero probability of ignition, is determined.

B.10 U.S. gap test. The U.S. gap test consists of exposing the sample to the shock stimuli from a 2-inch diameter x 2-inch long pentolite booster. The sample is confined in 1.45-inch diameter x 16-inch long steel tubing with a steel witness plate at the end opposite the booster. The reaction is detected by: (a) the condition of the witness plate, (b) the container damage, and (c) a velocity probe located in the sample container. The sample is said to be reactive if any two of the above test criteria agree, with criteria being a hole in witness plate, container completely fragmented, or velocity probe indicating a velocity greater than 1.5 km/sec.

B.11 U.S. internal ignition test. This is a closed tube deflagration-to-detonation test which is likely to be adopted by the EPA for RCRA purposes. A standard sample container (sch. 80 carbon steel pipe) is capped at both ends with steel pipe caps. The sample is subjected to thermal/pressure stimulus from an ignitor capsule located at the center of the sample vessel. A positive result is evidenced if either the pipe or one of the end caps is fragmented into at least two pieces.

APPENDIX C

USATHAMA METHOD 8H: EXPLOSIVES IN SOIL BY HPLC

METHOD NO.: 8H

DATE: 4-21-83

EXPLOSIVES IN SOIL BY HPLC

I. APPLICATION: Determination of the following nitro-compounds in soil.

HMX	Octahydro-1,3,5,7-tetranitro-1,3,5,7-tetrazocine
RDX	Hexahydro-1,3,5-trinitro-s-triazine
NB	Nitrobenzene
1,3-DNB	1,3-Dinitrobenzene
1,3,5-TNB	1,3,5-Trinitrobenzene
2,4-DNT	2,4-Dinitrotoluene
2,6-DNT	2,6-Dinitrotoluene
2,4,6-TNT	2,4,6-Trinitrotoluene
Tetryl	2,4,6-Trinitrophenylmethylnitramine

A. Tested Concentration Range:

HMX	0.376-188	ug/g
RDX	0.253-127	ug/g
NB	0.197-98.4	ug/g
1,3-DNB	0.242-121	ug/g
1,3,5-TNB	0.215-107	ug/g
2,4-DNT	0.240-120	ug/g
2,6-DNT	0.217-109	ug/g
2,4,6-TNT	0.301-151	ug/g
Tetryl	0.265-133	ug/g

B. Sensitivity: Peak height near the detection limit. (1 mm = 28 arbitrary units on the integrator readout.) Representative chromatogram near the detection limit can be found in Appendix I.

Peak Height in mm at
an Attenuation of 2⁻²

HMX	12 mm	for 0.754 ug/g
RDX	18 mm	for 0.506 ug/g
NB	11 mm	for 0.394 ug/g
1,3-DNB	23 mm	for 0.485 ug/g
1,3,5-TNB	20 mm	for 0.430 ug/g
2,4-DNT	16 mm	for 0.480 ug/g
2,6-DNT	9 mm	for 0.434 ug/g
2,4,6-TNT	19 mm	for 0.602 ug/g
Tetryl	10 mm	for 0.530 ug/g

C. Detection Limits:

HMX	0.376 ug/g
RDX	0.474 ug/g
NB	0.197 ug/g
1,3-DNB	0.242 ug/g
1,3,5-TNB	0.231 ug/g
2,4-DNT	0.240 ug/g
2,6-DNT	0.217 ug/g
2,4,6-TNT	0.301 ug/g
Tetryl	0.265 ug/g

D. Interferences:

1. Any compound that is extracted from soil that gives a retention time similar to the nitro-compounds and absorbs U.V. at 250 nm.
2. Millipore GFWP-01300 filter type GS pore size 0.22 micrometers dissolve in the solvent used.
3. Tetryl and 2-amino-4,6-dinitrotoluene coelute. If a tetryl peak is found in samples, pH adjustment is necessary to separate the peaks to determine which compound is present.
4. 2,4,6-Trinitrobenzaldehyde decomposes rapidly in water solution. Once the acetonitrile standard is made into mobile phase this becomes a problem.

E. Analysis Rate:

After instrument calibration, one analyst can analyze two samples in one hour. One analyst can conduct sample preparation at a rate of three samples per hour. One analyst doing both sample preparation and the HPLC analysis can run 16 samples in an 8-hour day.

II. CHEMISTRY:

A. Chemical Abstracts Service Registry Number:

HMX	2691-41-0
RDX	121-82-4
NB	98-95-3
1,3-DNB	99-65-01
1,3,5-TNB	99-35-4
2,4-DNT	121-14-2
2,6-DNT	606-20-2
2,4,6-TNT	118-96-7
Tetryl	479-45-8

B. Chemical Reactions:

1. RDX and HMX can undergo alkaline hydrolysis.
2. RDX and HMX degrade at temperatures greater than 80°C in an organic solvent.

C. Physical Properties:

	Formula	Mol. Wt.	M.P. (°C)	B.P. (°C)
HMX	$C_4H_8N_8O_8$	296.16	276	-
RDX	$C_3H_6N_6O_6$	222.12	205	-
NB	$C_6H_5NO_2$	123.11	6	211
1,3-DNB	$C_6H_4N_2O_4$	168.11	90	302
1,3,5-TNB	$C_6H_3N_3O_6$	213.11	122	315
2,4-DNT	$C_7H_6N_2O_4$	182.14	71	300 (decomposes)
2,6-DNT	$C_7H_6N_2O_4$	182.14	66	-
2,4,6-TNT	$C_7H_5N_3O_6$	227.13	82	240 (decomposes)
Tetryl	$C_7H_5N_5O_8$	287.15	131	187

III. APPARATUS:

- A. Instrumentation:** Perkin Elmer series 4 High Performance Liquid Chromatograph (HPLC) equipped with a Perkin Elmer ISS-100 Auto-Injector and Perkin Elmer variable wavelength detector LC-75. Hewlett Packard 3390 recording integrator in peak height mode was used to record the data output.

B. Parameters:

1. Column: Two columns are used in series, in the order listed.

- a. DuPont Permaphase^R ODS guard column.
- b. DuPont Zorbax^R ODS 4.6 mm i.d. x 25 cm HPLC column with a particle size of 5-6 microns.

2. Mobile Phase: The water/methanol ratio must be adjusted as described in the calibration Section V C to obtain optimum peak separation.

44-50% water
28-34% methanol
22% acenotrile

3. Flow: 1.6 mL/min with a pressure of approximately 2860 psig.

4. Detector: 250 nm

5. Injection Volume: 50 uL

6. Retention Times: Minutes

HMX	3.38
RDX	4.21
NB	7.33
1,3 DNB	6.63
1,3,5-TNB	5.74
2,4-DNT	9.89
2,6-DNT	9.50
2,4,6-TNT	8.93
Tetryl	7.98

C. Hardware/Glassware:

- 1. Syringes: 25 uL, 50 uL, 100 uL, 250 uL,
5 mL gas tight syringe (Hamilton 1005 TEFL)
- 2. Serum vials with crimp caps and Teflon-lined septa
Nominal volume of 0.25 mL, 1 mL, 5 mL.
- 3. Pasteur pipettes and disposable micropipettes.
- 4. 13 mm stainless steel syringe filter holder
(Rainin Instrument Co., Inc. #38-101)

C. Hardware/Glassware: (continued)

5. 13 mm x 0.5 micron fluorocarbon filter
 (Rainin Instrument Co., Inc. #38-103 Zefluor disc)
6. Whatman 10 mm glass microfiber prefilter
7. U.S. Sieve series 600 (30 mesh)
8. Aluminum foil pans
9. Liquid chromatograph column 1" o.d. x 12"
10. 2 mL, 3 mL, and 5 mL pipettes

D. Chemicals:

1. Acetonitrile, distilled in glass for HPLC use
2. Methanol, distilled in glass for HPLC use
3. Ethyl Ether, distilled in glass for HPLC use
4. Hexane, distilled in glass for HPLC use
5. ASTM Type II Water
6. SARMs for the nitro-compounds

IV. STANDARDS: All concentrations are based on a stock solution concentration of 2000 mg/L. Appropriate adjustments should be made if actual concentration varies from this figure.

A. Calibration Standards:

1. Stock Calibration Standards: Stock solutions containing approximately 2000 mg/L of a nitro-compound are prepared by accurately weighing 10 mg of a SARM into a 5 mL serum bottle and dissolving the nitro-compound in 5 mL of acetonitrile pipetted into the bottle. All compounds appear to be stable for 3 months.
2. Intermediate Calibration Standards: All compounds appear to be stable for 3 months.
 1. Intermediate Calibration Standard A (high level): Add the following volumes of stock calibration standard and seal with a Teflon-lined septum cap. Store in the dark @ 0°-4°C. The resulting solution (5.8 mL) will have the concentrations indicated in the following table.

USATHAMA CERT.
EXPLOSIVES IN SOIL BY HPLC

A. Calibration Standards: (continued)

Intermediate Calibration Standard A

Nitro-compound	Amt. (uL) of Stock Cal. Std. to add	Resulting conc. (ug/mL)
HMX	1000	345
RDX	600	207
NB	400	138
1,3-DNB	500	172
1,3,5-TNB	500	172
2,4-DNT	500	172
2,6-DNT	500	172
2,4,6-TNT	700	241
Tetryl	600	207
TNBA*	500	172

*2,4,6-Trinitrobenzaldehyde was originally included for certification. However, the compound is too unstable in water solutions to obtain reproducible certification data. It was included in this table as it affects the total volume used to calculate concentration of the other nitro-compounds.

b. Intermediate Calibration Standard B (low level):

Pipette 4.5 mL of acetonitrile into a 5-mL serum vial. Add 500 uL of Intermediate Calibration Standard A. Seal with a Teflon-lined septum cap and store in the dark @ 0-4°C. The resulting solution (5.0 mL) will have the concentrations indicated in the table below:

Intermediate Calibration Standard B

Nitro-Compound	Resulting conc. (ug/mL)
HMX	34.5
RDX	20.7
NB	13.8
1,3-DNB	17.2
1,3,5-TNB	17.2
2,4-DNT	17.2
2,6-DNT	17.2
2,4,6-TNT	24.1
Tetryl	20.7

A. Calibration Standards: (continued)

3. Working Calibration Standards: To a series of ten 5-mL serum vials, approximately one gram of prepared soil (see section V.B.) is accurately weighed into each vial. Using a syringe, the volumes of intermediate standard solutions indicated in the following table are injected onto soil. The serum vial is covered with a septum and shaken until the soil no longer looks wet (approximately 60 seconds). The septum is removed and the indicated amount (see Table below) of acetonitrile is pipetted onto the soil. The septum is replaced and the cap crimped on the vial. The sealed sample is blended on a vortex mixer for approximately 2-3 minutes. The sample is prepared via the procedure given in this method, to give the target concentrations in the following table.

WORKING CALIBRATION STANDARDS

Rel. Conc.	Amt. (uL) Intermed. Cal. Std. to Add		Amt. (mL) Aceto-Nitrile to Add	Resulting Concentration (ug/g)				
	A	B		HMX	2,4,6-TNT	Tetryl	1,3-DNB; 1,3,5-TNB; 2,6-DNT; 2,4-DNT	NB
0	0	0	2.0	0	0	0	0	0
0.1 X	-	12	2.0	0.414	0.289	0.248	0.206	0.166
0.2 X	-	24	2.0	0.828	0.578	0.497	0.413	0.331
0.5 X	6	-	2.0	2.07	0.145	1.42	1.03	0.828
1 X	12	-	2.0	4.14	2.89	2.48	2.06	1.66
2 X	24	-	2.0	8.28	5.78	4.97	4.13	3.31
5 X	60	-	2.0	20.7	14.5	14.2	10.3	8.28
10 X	120	-	1.9	41.4	28.9	24.8	20.6	16.6
25 X	240	-	1.8	82.8	57.8	49.7	41.3	33.1
50 X	600	-	1.4	207	145	142	103	82.8

B. Control Spikes: Control spikes are prepared in the same manner as the calibration standards.

V. PROCEDURE:

*NOTE THE FOLLOWING SAFETY PRECAUTIONS:

1. A 5-mL gas tight syringe (Hamilton 1005 TEFL) is used, as the teflon/glass seal is less likely to cause an explosion than glass/glass.

USATHAMA CERT.
 EXPLOSIVES IN SOILS BY HPLC

2. The nitro-compounds are less reactive when wet, so every precaution should be taken to ensure that work areas are kept clean and that solutions are not left unattended and allowed to dry.
3. The filtering apparatus is immersed in a water bath and disassembled under water immediately after use. The danger here is solution getting dried on the threads of the filtering apparatus and detonating.
4. When preparing SARM stock standards from pure compounds which are stored in water, small aliquots are scooped onto a nylon or polyvinylidene chloride filter. The water is vacuum filtered off and an appropriate quantity of the "dried" material is weighed out for stock standard preparation. Any extra compound thus dried is disposed of.
5. Prior to working with explosives, it is advisable to discuss safety/handling/storage requirements with an explosives expert.

A. Sample Preparation: The soil sample is removed from the sample bottle and spread out in aluminum foil trays. The sample is air dried. The dried soil is screened through a US series 600 sieve (30 mesh). This screened sample is subsampled according to ASTM procedure D346. The moisture content is determined by ASTM Method D2216-71.

B. Extraction:

1. Accurately weigh 1 gram of prepared soil (see section V.A. above) into a 5-mL serum vial, and pipette 2 mL of acetonitrile onto the soil.

Place a septum and cap on the vial, crimp into place, and shake the vial thoroughly on a vortex mixer for 2-3 minutes.

2. Set up the filtering apparatus, as shown.

5-mL syringe barrel (plunger removed)

5-mL syringe fitted with a Rainin 13 mm stainless steel filter holder with a 10 mm glass microfiber prefilter and a 0.5 micron fluorocarbon filter.

1 mL serum vial to collect filtered sample

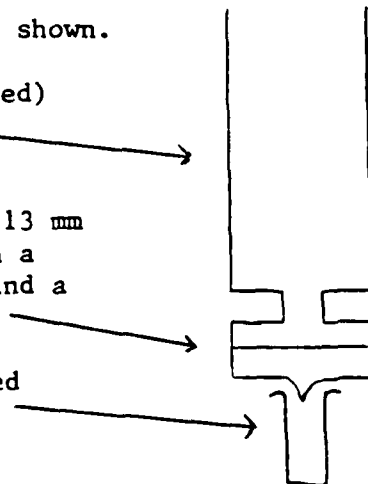

V. PROCEDURE: (continued)

3. Prepare the sample for injection as follows:
 - a. Pour the sample extract into the syringe.
 - b. Place the plunger in the syringe and force at least 500 μ L of the filtrate into a 1-mL serum vial.
 - c. Using a disposable micropipette, accurately measure 200 μ L of filtered extract into a 1-mL serum vial. Accurately measure 600 μ L of a 33% methanol/67% water solution onto the filtered sample. This will produce 800 μ L of extracted sample in mobile phase.
 - d. Place a septum and cap on the vial and crimp into place. Shake the vial well to thoroughly mix. Store in the dark @ 0-4°C until ready to analyze.
4. For samples outside the calibration range, a smaller sample volume is extracted into 5-mL of acetonitrile.
 - a. Accurately weigh 0.2 gram of prepared soil into a 5-mL serum vial, and pipette 5 mL of acetonitrile onto the soil. Place a septum and cap on the vial, crimp into place, and shake the vial thoroughly on a vortex mixer for 2-3 minutes.
 - b. Prepare the sample for injection as follows:
 - 1) Pour the sample extract into the syringe.
 - 2) Place the plunger in the syringe and force at least 3 mL of the filtrate into a 5-mL serum vial.
 - 3) Using a disposable pipette, accurately measure 1 mL of filtered extract into a 5-mL serum vial. Accurately measure 3 mL of a 33% methanol/67% water solution onto the filtered sample. This will produce 4 mL of extracted sample in mobile phase.

Alternately, the sample extract and methanol/water solution may be accurately weighed into a 5-mL serum vial. (1 mL \approx 1 g)

- 4) Place a septum and cap on the vial and crimp into place. Shake the vial well to thoroughly mix. Store in the dark @ 0-4°C until ready to analyze.
- c. If the solution prepared from the 0.2 g sample is still above the calibration range, make dilutions of the extract obtained in 4b(1) by taking an appropriate aliquot and adding mobile phase (e.g. 100 mg of acetonitrile sample extract in 20 mL mobile phase) to produce a solution within the calibration range of the instrument.

C. Instrument Calibration/Sample Analysis:

1. Using the auto-injector manufacturer's recommended procedure, introduce 50 uL of the 2X working calibration standard into the chromatographic system. Check the chromatogram to ensure separation of the nitrated toluenes and separation of the nitrobenzene and tetryl. If necessary, adjust the water/methanol ratio of the mobile phase until separate peaks are distinguished. As the column ages, less methanol is required. Generally, the column ages rapidly the first 24 hours, after which it is fairly stable.
2. Once good peak separation is obtained, introduce 50 uL of each working calibration standard and sample into the chromatographic system using the auto-injector manufacturer's recommended procedure.

VI. CALCULATIONS:

A. Sample Concentration (ug/g) = $\frac{(\text{peak ht.} - K) \times C \times E}{\text{slope} \times A \times B \times D}$

where:

K = y-intercept of the calibration curve regression line

slope = slope of the calibration curve regression line

A = $\frac{8 \text{ mL mobile phase}}{1 \text{ gram sample}}$ = a constant for this method.

Explanation: the instrument reads the total ug in the 50 uL aliquot of sample injected. This constant enables results to be interpreted as ug/g, as the calibration curve in ug/g is obtained by

$$\frac{2 \text{ mL acetonitrile to extract}}{1 \text{ gram calibration std. sample}} \times \frac{4 \text{ mL mobile phase}}{1 \text{ mL acetonitrile extract}}$$

VI. CALCULATIONS: (continued)

- B = sample weight
- C = mL acetonitrile used to extract sample
- D = mL acetonitrile extract diluted into mobile phase
- E = final volume in mL of mobile phase prepared for injection

NOTE: When samples are prepared the same as the calibration standards (1 gram extracted into 8 mL of mobile phase), the above calculation becomes:

$$\begin{array}{l} \text{Sample} \\ \text{Concentration} \\ \text{(ug/g)} \end{array} = \frac{(\text{Peak height} - K)}{\text{slope}}$$

B. All soils data must be reported on a moisture-free basis. Moisture content is determined by ASTM D2216-71. 100%-% Moisture = % solids.

$$\begin{array}{l} \text{Concentration on a} \\ \text{moisture free basis} \end{array} = \frac{\text{analyte concentration}}{\% \text{ solids}} \times 100$$

VII. REFERENCES:

- A. USATHAMA Method 2C Cyclotrimethylenetrinitramine (RDX) in Soil and Sediment Samples, 12-3-80.
- B. USATHAMA Method 8H Explosives in Water by HPLC, 12-27-82.

END

FILMED

2-86

DTIC