

MICROCOPY RESOLUTION TEST CHART
NATIONAL BUREAU OF STANDARDS-1963-A

12



U.S. Office of Naval Research, London
Vol 40 No. 1/January 1986

AD-A162 235

European Science Notes

<u>Forum</u>	<u>1</u>
<u>Acoustics</u>	<u>1</u>
<u>Biological Sciences</u>	<u>1</u>
<u>Chemistry</u>	<u>14</u>
<u>Engineering</u>	<u>18</u>
<u>Material Sciences</u>	<u>21</u>
<u>Physics</u>	<u>24</u>

DTIC FILE COPY

DTIC
ELECTE
DEC 1 0 1985
S E D

*5 12 6 002

REPORT DOCUMENTATION PAGE

1a. REPORT SECURITY CLASSIFICATION UNCLASSIFIED			1b. RESTRICTIVE MARKINGS			
2a. SECURITY CLASSIFICATION AUTHORITY			3. DISTRIBUTION / AVAILABILITY OF REPORT Approved for public release; distribution unlimited			
2b. DECLASSIFICATION / DOWNGRADING SCHEDULE						
4. PERFORMING ORGANIZATION REPORT NUMBER(S) 40-1			5. MONITORING ORGANIZATION REPORT NUMBER(S)			
6a. NAME OF PERFORMING ORGANIZATION US Office of Naval Research Branch Office, London		6b. OFFICE SYMBOL (if applicable) ONRL	7a. NAME OF MONITORING ORGANIZATION			
6c. ADDRESS (City, State, and ZIP Code) Box 39 FPO, NY 09510			7b. ADDRESS (City, State, and ZIP Code)			
8a. NAME OF FUNDING / SPONSORING ORGANIZATION		8b. OFFICE SYMBOL (if applicable)	9. PROCUREMENT INSTRUMENT IDENTIFICATION NUMBER			
8c. ADDRESS (City, State, and ZIP Code)			10. SOURCE OF FUNDING NUMBERS			
			PROGRAM ELEMENT NO.	PROJECT NO.	TASK NO.	WORK UNIT ACCESSION NO.
11. TITLE (Include Security Classification) European Science Notes-- (UNCLASSIFIED)						
12. PERSONAL AUTHOR(S) Larry E. Shaffer, Editor						
13a. TYPE OF REPORT Monthly		13b. TIME COVERED FROM _____ TO _____		14. DATE OF REPORT (Year, Month, Day) January 1986	15. PAGE COUNT 38	
16. SUPPLEMENTARY NOTATION						
17. COSATI CODES			18. SUBJECT TERMS (Continue on reverse if necessary and identify by block number) <i>1. 1. 1.</i>			
FIELD	GROUP	SUB-GROUP				
19. ABSTRACT (Continue on reverse if necessary and identify by block number) European Science Notes (ESN) is a monthly publication with brief articles on recent developments in European scientific research. The publication is not intended to be part of the scientific literature. The value of ESN articles to Americans is to call attention to current developments in European science and technology and to the institutions and people responsible for these efforts. ESN authors are primarily ONRL staff members. Occasionally articles are prepared by or in cooperation with staff members of the USAF European Office of Aerospace Research and Development or the US Army Research, Development and Standardization Group. Qualified US scientists travelling in Europe may also be invited to write an ESN article.						
20. DISTRIBUTION / AVAILABILITY OF ABSTRACT <input checked="" type="checkbox"/> UNCLASSIFIED/UNLIMITED <input type="checkbox"/> SAME AS RPT <input type="checkbox"/> DTIC USERS			21. ABSTRACT SECURITY CLASSIFICATION UNCLASSIFIED			
22a. NAME OF RESPONSIBLE INDIVIDUAL Larry E. Shaffer			22b. TELEPHONE (Include Area Code) (44-1) 409-4340		22c. OFFICE SYMBOL 11	

European Science Notes

US Office of Naval Research, London

Commanding Officer CAPT M.A. Howard, USN
Scientific Director David L. Venezky
Editor Larry E. Shaffer

January 1986
Volume 40
Number 1

Forum

ESN Needs More on Semiconductor R&D Stuart A. Hoenig 1

ESN Available by Subscription Walter C. Granville 1

Acoustics

Shallow Water Acoustics at the UK's
Royal Aircraft Establishment J. Thomas Warfield 1

The importance of antisubmarine warfare in shallow water regions places a corresponding emphasis on shallow water acoustics. Fundamental analytical work at the UK's Royal Aircraft Establishment focuses on obtaining solutions to the acoustic wave equation that reveal the full three-dimensional structure of the acoustic field in shallow water regions, such as over a sloping bottom or near a seamount.

Biological Sciences

New ONRL Report Examines Immunology
Research in Israel Claire E. Zomzely-Neurath 7

ONR, London, report R-6-85 covers Israeli advances in immunology. Areas in immunology research currently being pursued by Israeli scientists include investigation of immunoglobulin genes, structure-function analysis of antibodies and regulation of antibody production and expansion; genetics of autoimmunity and cancer; lymphokines and complement; autoimmunity; tumor immunology; transplantation and tissue-typing; clinical immunology; infectious diseases; and applied immunology.

Weizmann Institute of Science;
Life Sciences Research Claire E. Zomzely-Neurath 7

Israel's Weizmann Institute is doing top-level research in neurobiology; parasitology; immunology; cancer; burn, wound, and fracture healing; and genetics.

Chemistry

IUPAC International Symposium on Macromolecules Oh-Kil Kim 14

Recent progress in conducting polymers research, focusing on important factors for polymer conductivity, was described in an invited lecture at the 30th International Symposium on Macromolecules. For the future, increasing attention is focused on the problems of stability and processability of conducting polymers. These problems were addressed at the symposium.

- Mass Spectrometry Meetings Held in
Wales and West Germany Mark M. Ross, Joseph E. Campana
and David A. Kidwell 15

Two meetings dealing with mass spectrometry were held in Europe last summer: the 10th International Mass Spectrometry Conference that emphasized fast-atom bombardment mass spectrometry techniques, and the Third International Workshop on Ion Formation From Organic Solids that brought together researchers studying or using desorption ionization. This article covers highlights of both meetings.

Engineering

- Automation and Robotization in
the Welding Industry Kenneth D. Challenger 18

Professor F. Eichhorn of Technischen Hochschule Aachen has analyzed the problems associated with robotization of industry and the possible side effects of robotization. This article summarizes a lecture presented by Eichhorn last September during the annual assembly of the International Institution of Welding.

Material Sciences

- The 3rd International Conference on Composite
Structures, Paisley College of Technology Kenneth D. Challenger 21

The Third International Conference on Composite Structures was held last September at Paisley College of Technology, Scotland. This article highlights presentations on the developments of materials, testing methods, and analytical codes.

Physics

- Small Conference on Quantum Electronics
Has Broad Scope Paul Roman 24

The Seventh National Quantum Electronics Conference of the UK was held in Malvern in September 1985. The major areas covered by well-prepared talks and substantial related discussions included laser, nonlinear optics, quantum optics, electro-optics devices, spectroscopy, and miscellaneous applications.

- Very Short Laser Pulse Research at TUM Paul Roman 25

A small but vigorous research group at the Physics Faculty of Munich's Technical University conducts experiments to produce very short laser pulses in the infrared, visible, and ultraviolet range. This article describes several laser systems and some studies in molecular dynamics in which very-short-pulse excite-and-probe techniques were used.

News and Notes

- Conference on Formation of Semiconductor Interfaces See-Chen Ying 30
Colloquium Spectroscopicum Internationale XXIV John V. Gilfrich 31
ESPRIT Progress Assessed by EEC J.F. Blackburn 31
NATO ASI on Kindling To Be Held in Italy David Mostofsky 33

Significant Progress in Multimode Fibers	Paul Roman	33
Advances in Optical Fiber Research in the UK	Paul Roman	33
Advanced High-Power CO ₂ Laser	Paul Roman	34
New International Journal To Cover the Interface of Chemistry and Electronics	Paul Roman	34
SERC Bulletin Reports Items of Interest to Chemists	David L. Venezky	34
Proceedings of the International Rare Earth Conference now in Print	David L. Venezky	36
ONRL Cosponsored Conferences		36
ONRL Reports		36
Science Newsbriefs		37
Military Applications Summary Bulletins		37

* * *

ESN Invites Letters to the Editor

ESN publishes selected letters related to developments and policy in science and technology in Europe and the Middle East or to interactions between the US and Europe and the Middle East in science and technology.

Letters intended for publication should be limited to 250 words and should include the writer's name, address, and daytime telephone number. Send your contributions to:

The Editor
 ESN
 Office of Naval Research Branch Office
 Box 39
 FPO, NY 09510-0700

Not all letters can be used; letters may be edited for reasons of space and clarity.

* * *

For	
<input type="checkbox"/>	
<input type="checkbox"/>	
By _____	
Distribution/ _____	
Availability Codes _____	
Dist	Avail and/or Special
A-1	

European Science Notes is a Class I Periodical prepared and distributed by the Office of Naval Research, London, in accordance with NAVSO P-35.

Forum

ESN NEEDS MORE ON SEMICONDUCTOR R&D

I noticed a request for comments in the last issue of *European Science Notes*, and here they are. I like *ESN* and often cut or copy items for selected faculty and friends in industry. As an engineering faculty member, I am certainly interested in science. In fact, I think of engineering as being applied science. I sometimes tell the students that it is the profits of applied science or engineering that pay the costs of basic research.

I, for one, would like to see some information in *ESN* on European industry, particularly that associated with semiconductor research and development. This is an area where the dividing line between science and engineering seems to disappear, in that the transition from basic research to technological applications is often a matter of months. In some cases, the system or device is on the market while the basic research, to understand it, is still under way.

While I would not wish to see *ESN* decrease its emphasis and coverage of science, some information on engineering would certainly be of value. One area of particular interest relates to contamination detection and control in semiconductor manufacturing. This seems to be the very cutting edge of the struggle for the market share between the US, Europe, and Japan. Any help that you might provide would be very welcome.

Stuart A. Hoenig
University of Arizona

ESN AVAILABLE BY SUBSCRIPTION

I can't tell you how pleased I was to receive a letter saying that *ESN* is available from the US Government Printing Office.

Many months ago I tried to subscribe, and they wanted \$20 for single articles and said that no subscription to the monthly issue was available. Thank you for pursuing this. I immediately sent them a check for a subscription.

Walter C. Granville
Libertyville, Illinois

Starting with this issue, January 1986, the US Government Printing Office will be offering subscriptions to *ESN*:

12 issues, domestic subscriber = \$27.00
12 issues, foreign subscriber = \$33.75
Single issue, domestic = \$2.25
Single issue, foreign = \$2.81

To subscribe, please write to the Superintendent of Documents, US Government Printing Office, Washington, DC 20402.--Ed.

Acoustics

SHALLOW WATER ACOUSTICS AT THE UK'S ROYAL AIRCRAFT ESTABLISHMENT

by J. Thomas Warfield. Dr. Warfield is the Liaison Scientist for Underwater Acoustics in Europe and the Middle East for the Office of Naval Research's London Branch Office. He is on reassignment until 1987 from the Office of Naval Research, Arlington, Virginia, where he is Deputy Project Manager for the Undersea Technology Project.

Shallow water acoustics is a subject of considerable interest in the naval research establishments of the UK because of its importance in antisubmarine warfare (ASW) in the wide continental shelf regions surrounding the island. This article begins a survey of the current UK research and development efforts on shallow water acoustics and sensors. The work described here is fundamental analytic work being carried out at the Royal Aircraft Establishment (RAE) in Farnborough. This establishment, with a total staff of about 6000, is one of the largest research establishments in Western Europe. It comprises 12 departments grouped in three major areas: electronics, air, and weapons.

The Air-Sea Warfare Division (RN3), located within the Radio and Navigation Department (RN), has the primary responsibility within the UK for development of sonobuoys and their associated signal processing algorithms and airborne data processors. Since 1981, RN3 Division has been led by Dr. Dennis Stansfield. Stansfield is well known within the US air ASW community at the Naval Air Systems Command, and also at the Naval Air Development Center, where he was an exchange scientist in the early 1970s.

A small but potent group led by Dr. Michael Buckingham, RN3/5, conducts research in theoretical acoustics and is a major contributor to shallow water acoustics in the UK. Buckingham is also known in the US acoustics community, having recently spent 2 years (1981-83) as an exchange scientist at the Naval Research Laboratory (NRL). In addition to his position at RAE, Buckingham also holds an appointment at the Institute of Sound and Vibration Research, Southampton University. Buckingham began the work described in this article in 1981, and is continuing research in the field of shallow water acoustics.

Background

Shallow water acoustics is more complicated than deep ocean acoustics owing ultimately to the closeness of the ocean bottom. In addition to requiring another factor to describe the propagation of underwater sound, the repeated and unavoidable interaction of sound with the nearby bottom results in a greater degree of variability than is usually found in deep water. Because of this variability, there is a greater need to deal with three-dimensional (3-D) problems in shallow water. This is in contrast to deep water, where we are often able to reduce the problem to the two dimensions of range and depth by accepting the approximation that the ocean environment is uniform and homogeneous in azimuth. Buckingham's work is concerned with 3-D problems in shallow water.

Modeling of 3-D acoustic fields is difficult, especially in shallow water. Numerical techniques, such as the parabolic equation (PE) method, work satisfactorily for two-dimensional problems, but most cannot handle 3-D fields. A 3-D numerical PE model is being developed at NRL, but at present it still requires lengthy computation. The HARPO code being developed at the Environmental Research Laboratories of the US National Oceanographic and Atmospheric Administration will also be able to handle 3-D problems. Ray methods can handle 3-D geometries relatively easily, but these methods must be used with great care and skill when the ratio of water depth to acoustic wavelength becomes small, as in shallow water.

Substantial research in shallow water acoustics is under way in the US, within the North Atlantic Treaty Organization (NATO), and in countries such as the UK, Canada, Australia, and New Zealand, in response to the renewed concern over shallow water ASW. Much of this work goes into developing numerical com-

puter codes for propagation modeling and signal-to-noise estimation. A complementary approach uses analytic techniques to solve formal mathematical representations of acoustics problems of interest. These analytical methods can provide valuable insight into the 3-D behavior of the sound field, even though idealizing approximations must be made. Such solutions can be regarded as canonical models which provide a mathematical basis for the quantitative understanding of the relationships between the multiple variables and parameters describing the sound field. They also provide a framework within which detailed numerical solutions can be interpreted, when such calculations become available. It is the analytic approach that Buckingham has taken, and he has been able to solve, and interpret, two important 3-D problems: the wedge and the cone.

The Wedge

The first problem undertaken was for the 3-D acoustic field produced by a point source in a wedge-shaped ocean--that is, an ocean region in which a planar sloping bottom falls away from the shoreline. The contour lines of constant depth are then straight lines parallel to the shoreline. More complicated geometries come readily to mind, such as curvilinear shorelines, nonlinear range-dependence of the depth profile, etc. But even in the relatively simple case of the wedge, the problem is fully 3-D if the source S and receiver (or field point) R do not fall in the same vertical plane perpendicular to the shoreline. And as is often the case with analytic problems, the analyst must carefully balance his desire to solve as complex a problem as possible on the one hand, against his skill and ability to carry the problem through to solution on the other. The problem as formulated by Buckingham achieves this balance nicely.

To make the problem analytically tractable, two idealizing assumptions were made: the sound speed was taken to be constant throughout the ocean wedge, and both the surface and the bottom were taken to be perfectly reflecting boundaries. Although these assumptions preclude certain real phenomena, such as acoustic penetration into the bottom, many important physical features of the sound field, such as the normal mode structure, are captured by this model, at least approximately. For an analytic approach, the decisive point regarding assumption of a perfectly reflecting bottom is that the wave equation is separable for a perfectly reflecting bottom, whereas for a penetrable bottom it is not.

The separability of the wave equation was realized by an astute choice of coordinates. To achieve separability, it is necessary that the physical boundaries coincide with coordinate surfaces. The physical boundaries are the horizontal ocean surface and the planar sloping bottom. A cylindrical coordinate system (r, θ, z) was chosen, with the horizontal ocean surface as the (r, z) plane and the shoreline as the z -axis. A vertical plane perpendicular to the shoreline is represented by $z = \text{const}$, and is an (r, θ) plane. Water depth within the ocean wedge is accounted for by the angular variable θ measured from the ocean surface down to a maximum of θ_0 , the angle of the sloping ocean bottom. The boundaries are thus $\theta = 0$ and $\theta = \theta_0$. The origin is chosen so that the point source S is in the plane $z = 0$ at coordinates $(r', \theta', 0)$.

In this coordinate system, the inhomogeneous Helmholtz equation for the velocity potential is separable, and is solved by applying a sequence of integral transforms (finite sine, Hankel, Laplace) that render the Helmholtz differential equation into a simple algebraic equation in the triply transformed space. Upon solving this equation, application of the inverse transforms then produces an exact solution for the velocity potential at a field point R at (r, θ, z) . This solution is in the form of a (finite) sum of normal modes of the type $I_n(r, r', z) \sin n\theta \sin n\theta'$, where the eigenvalues n serve as the index of summation. The amplitude I_n is given by an integral generally requiring numerical evaluation, and the sine functions contain the entire angular (depth) dependence of the modes in the wedge. This is a compact and usable solution. The numerical integration required for the I_n is not excessive, and the integral can also be approximated by a linear sum of two Hankel functions, if the acoustic frequency of the source is not too low.

This solution was then analyzed for the spatial properties of the modes. To me, the most interesting result of these analyses was that each mode has an amplitude significantly different from zero only within a certain domain surrounding the source point, with shadow zones outside the domain. Within the domain, the modal amplitude is a highly oscillatory function of the position of the field point. Buckingham termed these domains "modal beams," since they broaden out in cross-range as the energy propagates out toward deep water. In fact, each modal beam domain is bounded by a branch of an hyperbola with the source at the focal point. The lowest order mode is the broadest, and success-

ively higher order mode domains are progressively tighter. Thus, the picture that emerges (see Figure 1) is one of a nested family of hyperbolae, each with the same focal point. As the receiving point R moves off the axis of the hyperbolae, the number of modes contributing to the sum decreases. This further simplifies the calculation of the field at these points, and may also serve to establish different zones of variability, or stability, of the acoustic field.

Making use of the duality between modes and rays, the hyperbolic shape of the modal beams was interpreted as a result of the horizontal refraction of rays induced by the sloping bottom. Horizontal refraction of rays over a sloping bottom has been discussed previously in the open literature (Weston, 1959; Weston, 1961; and Harrison, 1979). Both of these earlier authors found that

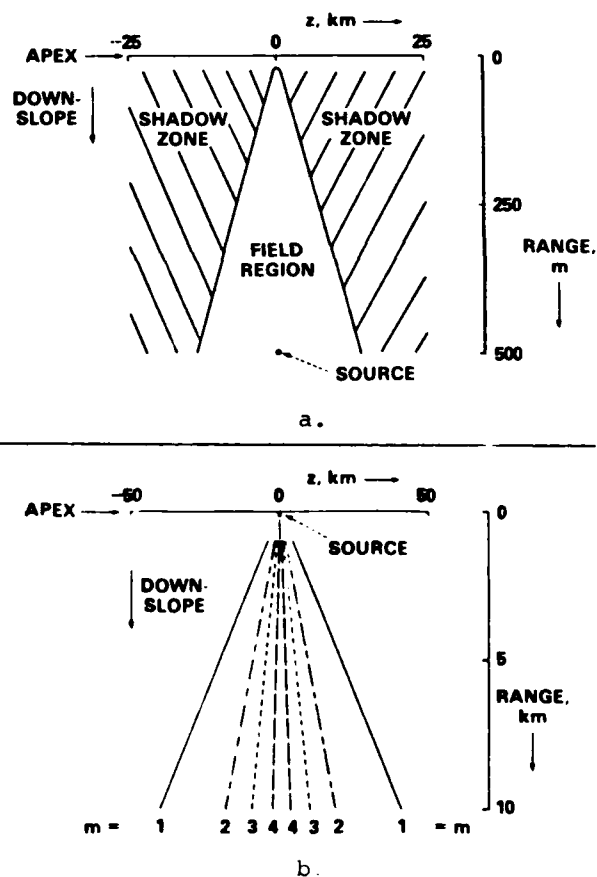

Figure 1. (a) The hyperbola separating the modal domain (field region) and the shadow zone for the first mode in a wedge-shaped ocean; (b) nested hyperbolae for modes $m=1 \dots 4$ (from Buckingham, 1984).

repeated interaction of the sound with the inclined plane of the bottom introduces curvature into the horizontal direction of the ray, and eventually leads to a turning point as the shoreline is approached. The hyperbola bounding a given modal beam in the (r,z) plane is shown to be the envelope of the ensemble of modal rays emanating from the source and associated with the mode. Thus, the ray and mode descriptions are complementary and consistent, with the modal solution giving a complete description of the field, including phase. Although limited somewhat by the assumption of a perfectly reflecting bottom interface, this solution offers a new and practical quantitative technique for the analysis of many shallow water acoustics problems.

The major features of this analysis have had some experimental verification. Buckingham (1984) points out that the modal beaming effect can be seen clearly in a photographic visualization of the sound field made by A.B. Wood in one of his model tank experiments in 1959 (Wood, 1959). Although not enough information is available on the arrangement of the apparatus for a quantitative comparison, Buckingham concludes that the overall features of the photograph, taken when Wood's model tank was filled with a planar sloping bottom, are qualitatively consistent with his theory. The analysis described here was presented by Buckingham in the A.B. Wood Memorial Lecture in April 1983, when he received the prestigious A.B. Wood Medal for his research in acoustics.

More comprehensive confirmation has been put forth (Doolittle et al., 1985), indicating that sea test data taken with a towed array and a towed narrowband (152 Hz) projector on the eastern continental slope of Australia appear consistent with the theoretical predictions of horizontal refraction. The two tow ships, separated by 33 km in cross-range (z) and initially at a range r approximately 25 km from shore, started at a 400-m depth contour and proceeded out to deep water on diverging tracks while maintaining equal distances from the shoreline. The angle of the sloping bottom was estimated to be 1.2 degrees. A bearing-time plot of the beam-formed narrowband data shows signal spreading in azimuth over 23 degrees from the direct path. Both ray and modal analyses are offered in support of the claim that the main mechanism responsible for the observed spread is horizontal refraction resulting from interaction with the sloping bottom. In the ray picture, rays leaving the projector at angles somewhat up-slope of the line-of-sight to the receiver

are refracted slightly down-slope at each bottom reflection, and the cumulative effect brings them to the receiver. However, these rays are spread out in azimuth rather than focused along the line-of-sight to the source. In addition, the normal mode solution was used to compute the field at each of the sensors in the array, and a synthetic bearing-time plot that matches the experimental data reasonably well was generated from the theoretical calculations.

The Cone

While working on the wedge problem, it became clear to Buckingham that the same strategy would work for a problem governed by the geometry of a cone. In this case, one can imagine the wedge to be wrapped around a vertical axis of revolution, thus forming a region complementary to a cone. The contour lines of constant depth are concentric circles, centered on the apex of the cone. Spherical coordinates replace the cylindrical coordinates appropriate for the wedge, and a canonical problem descriptive of an ocean volume overlying a conical seamount results. This analysis has been submitted for publication (Buckingham, 1986).

This problem was formulated in much the same way as the problem for the wedge. The sound speed was again taken to be constant, and both the ocean surface and the seamount surface were taken to be perfect reflectors. The apex of the seamount is assumed to just touch the sea surface. Thus, the boundaries of the channel can be represented by the surfaces of a separable coordinate system, in this case spherical polar (r, θ, ϕ) with the origin at the apex. Range r is measured radially outward from the apex, the polar angle θ is measured from the downward vertical, and the azimuth angle ϕ is measured from the source bearing. The same strategy is followed as in the wedge problem: a sequence of integral transforms is applied that reduces the inhomogeneous Helmholtz differential equation to a simple algebraic equation in the triply transformed space, followed by the corresponding sequence of inverse transforms.

In this problem, the sequence of transforms is finite cosine, generalized Legendre, and Hankel. The generalized Legendre transform uses a linear combination of associated Legendre functions of the first and second kind as its kernel rather than either alone. Buckingham had to define and formulate this transform in order to satisfy the pressure-release boundary condition on the sea surface. As a result, the mode functions are generalized Legendre functions

of argument $\cos\theta$ or $\cos\theta'$ (receiving point and source point, respectively). As these generalized Legendre functions are doubly indexed, the formal solution involves a double summation, one over each index.

A difficulty arises in trying to satisfy the boundary condition at the lower boundary--i.e., the seamount. This condition determines the eigenvalues in one of the two indices of the generalized Legendre function. Unfortunately, the resulting equation cannot be solved analytically for the eigenvalues. This difficulty was overcome by using asymptotic approximations for the generalized Legendre functions that are valid when the angular measure of the ocean channel is small. As the maximum slope of the approximately 20,000 seamounts in the world's oceans does not exceed more than about 22 degrees down from the sea surface, this approximation is not too limiting.

These approximations reduce the generalized Legendre functions to trigonometric functions, and the eigenvalues can then be found. The resulting mode functions are essentially the same as in the wedge problem, although the complex mode amplitude is substantially different. In contrast to the wedge problem, the complex mode amplitude is given by a Fourier series, each coefficient of which is a product of a Hankel and a Bessel function.

However, this series is slow to converge, possibly requiring several hundred terms in realistic problems of interest. Thus, computation of a single field point in the (r, ϕ) plane would be lengthy, and evaluation of many such points to assess the field throughout a region would be prohibitively slow. To overcome this difficulty, Buckingham was able to reformulate the series for the complex mode amplitude into an integral representation reminiscent of the mode amplitude integral found in the wedge problem. This brings the solution into the realm of practicality, since only one numerical integration is now required at each field point.

Numerical investigation of the range dependence of the magnitude of the lowest order mode yielded curves similar in character to the wedge problem. The most striking property, also found in the wedge problem, is that the mode amplitude decays very rapidly toward zero once the range gets short--i.e., once the water depth is no longer great enough to support the mode. (In ray terms, a ray traveling up the seamount has its grazing angle increased at each bottom reflection, until it exceeds $\pi/2$, at which point the ray reverses direc-

tion and travels back down the seamount.)

Holding the range fixed and numerically examining the azimuthal behavior of the magnitude of the mode amplitudes reveals a set of nested modal domains analogous to those found in the wedge problem. Each mode has an amplitude significantly different from zero only within a certain domain around the source point. A shadow zone is formed near the apex of the seamount and broadens out in cross-range as the field point moves out in range behind the seamount. Within the domain, the modal amplitude is a highly oscillatory function of position. The lowest order mode has the smallest shadow zone, and successively higher order modes have progressively larger shadow zones (see Figure 2). Just as in the wedge, the number of modes effectively contributing to the total acoustic field depends on the location of the field point. This feature may serve to establish different zones of variability, or stability, of the acoustic field propagated from a source point.

This simple approximate formula derived by Buckingham for the half-angle of the modal shadow zones is exactly the

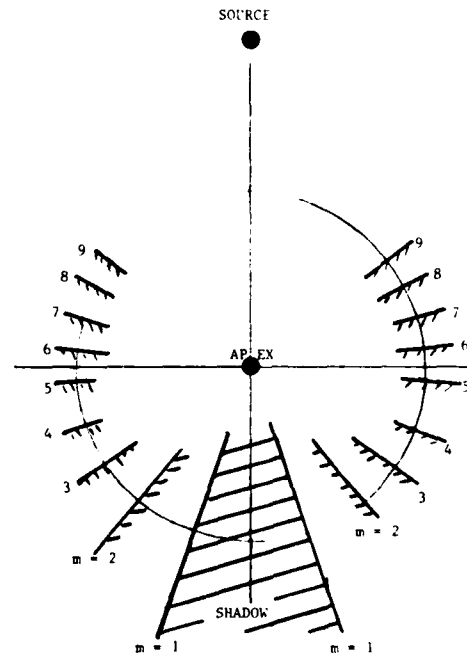

Figure 2. Shadow zones for the first nine modes ($m=1..9$) in an ocean region near a conical seamount.

same as one derived earlier by Harrison (1979). Buckingham obtained his result by using the method of stationary phase on the integral expression for the mode amplitude. Harrison used ray theory where the shadow zones are formed by horizontal refraction of the modal rays reflecting off the conical seamount (see Figure 3). This agreement between two rather disparate methods of analysis to predict both the existence and shape of the modal shadow zones lends considerable credibility for their existence in the real ocean. However, to the best of my knowledge, experimental verification at sea has not yet been attempted.

Summary

The 3-D acoustic field has been found in canonical formulations representative of shallow water overlying a sloping bottom or a seamount. Both solutions express the field in terms of a finite sum of normal modes, with each mode amplitude requiring a numerical integration. The solutions give both phase and amplitude, and are thus suitable for various calculations such as array performance and spatial coherence. In this last context, Buckingham has also used the wedge solution to calculate the power spectral density and coherence functions for surfaced noise sources in a wedge (Buckingham, 1985).

The modal shadow zones predicted by this analysis, and the horizontal refraction effects predicted earlier by Harrison (1979) and Weston (1961) are potentially strong 3-D effects. As such,

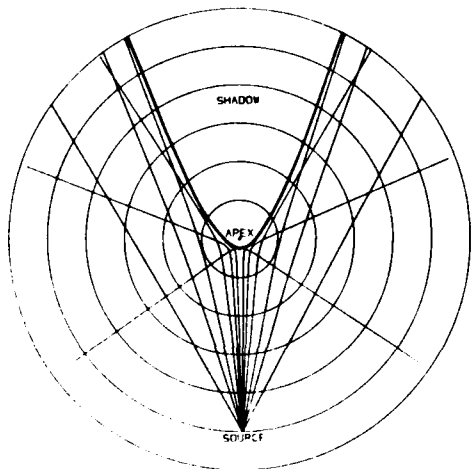

Figure 3. Horizontal refraction of modal rays near a conical seamount and the resulting shadow zone, $m=1$ (from Buckingham, 1984).

we ought to be keenly interested in them. Although this is not the forum to discuss applications, it can be remarked here that these effects are not just academic curiosities. Rather, they are typical of the kinds of environmental variations that we must understand, not only to avoid serious degradation of system performance in certain areas, but also to use and exploit whenever possible for any acoustic advantage the environment may offer.

References

- Buckingham, M.J., "Acoustic Propagation in a Wedge-Shaped Ocean With Perfectly Reflecting Boundaries," in *Proceedings of the NATO Advanced Research Workshop on Hybrid Formulation of Wave Propagation and Scattering* (IAFE, Castel Gandolfo [Rome], Italy, 30 August-3 September 1983), 77-105. (Also published as NRL Report 8793, March 1984.)
- _____, "A Theoretical Model of Surface-Generated Noise in a Wedge-Shaped Ocean With Pressure-Release Boundaries," *Journal of the Acoustical Society of America*, 78 (1985), 143-148.
- _____, "Theory of Acoustic Propagation Around a Conical Seamount," submitted to *Journal of the Acoustical Society of America*, expected publication date, January 1986.
- Doolittle, R., A. Tolstoy, and M.J. Buckingham, "Experimental Confirmation of Horizontal Refraction of CW Sound Propagation in a Wedge-Like Ocean," in *Proceedings of the International Conference on Ocean Seismo-Acoustics* (SACLANT ASW Research Centre, La Spezia, Italy, 10-14 June 1985).
- Harrison, C.H., "Acoustic Shadow Zones in the Horizontal Plane," *Journal of the Acoustical Society of America*, 65 (1979), 56-61.
- Weston, D.E., "Guided Propagation in a Slowly Varying Medium," *Proceedings of the Physical Society*, 73 (1959), 365-384.
- _____, "Horizontal Refraction in a Three-Dimensional Medium of Variable Stratification," *Proceedings of the Physical Society*, 78 (1961), 46-52.
- Wood, A.B., "Model Experiments on Sound Propagation in Shallow Seas," *Journal of the Acoustical Society of America*, 31 (1959), 1213-1235.

10/15/85

Biological Sciences

NEW ONRL REPORT EXAMINES IMMUNOLOGY RESEARCH IN ISRAEL

by Claire E. Zomzely-Neurath. Dr. Zomzely-Neurath is the Liaison Scientist for Biochemistry, Neurosciences, and Molecular Biology in Europe and the Middle East for the Office of Naval Research's London Branch Office. She is on leave until July 1988 from her position as Director of Research, the Queen's Medical Center, Honolulu, Hawaii, and Professor of Biochemistry, University of Hawaii School of Medicine.

ONR, London, has recently published a report on Israel's advances in immunology. Report R-6-85, *Immunology Research in Israel*, observes that research in immunology has developed and flourished in Israel.

In the 1920s and 1930s, scientists at the Hebrew University in Jerusalem were already active in areas related to immunology. The parasitologists S. Adler and G. Mer and the bacteriologist N. Kleigler made contributions that played a major role in the complete eradication of malaria from the region of what was then called Palestine. In 1934, Dr. Chaim Weizmann founded the Daniel Sieff Research Institute. By 1947, this had expanded into what is today the world-renowned, multidisciplinary Weizmann Institute of Science.

By 1962, research there had led to the development of synthetic antigens and their use for the elucidation of many facets of immunological phenomena, including the molecular basis of antigenicity. At the same time, immunology on a more cellular level with special relevance for cancer research was already being studied extensively. In the late 1960s D. Weiss (University of California, Berkeley) joined the Weizmann Institute to set up programs in immunopotentialiation and cancer research.

The Hebrew University's Hadassah Medical School has made important contributions to the cellular aspects of immunology. Research here has pioneered in the field of histocompatibility and antigens, and it was the first to show the theta antigen as a murine T-cell marker.

Scientists at these and other Israeli institutions are contributing to our knowledge of the many facets of immunological phenomena. These scientists

have received international recognition for their research. Collaborative efforts between research institutions and the new biotechnological industries continue to produce significant results.

Areas in immunology research currently being pursued by Israeli scientists include investigation of immunoglobulin genes, structure-function analysis of antibodies, and regulation of antibody production and expansion; genetics of autoimmunity and cancer; lymphokines and complement; autoimmunity; tumor immunology; transplantation and tissue-typing; clinical immunology; infectious diseases; and applied immunology.

For more details, see report R-6-85. To order the report, fill out the return mailer inside the back cover of this issue.

10/18/85

WEIZMANN INSTITUTE OF SCIENCE: LIFE SCIENCES RESEARCH

by Claire F. Zomzely-Neurath.

The Weizmann Institute of Science, located in Rehovot, Israel, is a center of excellence in scientific research. The institute members are carrying out basic and applied research in a wide range of subjects, with particular emphasis on the life sciences. There are programs in areas such as neurosciences, molecular genetics, cell biology, and immunology. Table 1 lists the various departments at the Institute and shows the scope of scientific fields covered at Weizmann.

This article deals with only some of the top-level biological research at the Weizmann Institute as the scope is too extensive to cover all areas.

Background

The Weizmann Institute was founded in 1949, incorporating the Daniel Sieff Research Institute, which was established in 1934 and was mainly concerned with agriculturally oriented projects as well as research and production of pharmaceuticals for the Allied forces in the Middle East during World War II. The institute bears the name of Dr. Chaim Weizmann, scientist and statesman, first president of the Weizmann Institute of Science, and later the president of the State of Israel. Weizmann was instrumental in obtaining financial support from

Table 1

Faculties and Departments at the
Weizmann Institute of Science

President: Professor Michael Sela

Faculty of Mathematical Sciences. Dean: Lee A. Segel
Department of Applied Mathematics. Head: Zvi H. Riesel
Department of Theoretical Mathematics. Head: Harry Dym

Faculty of Physics. Dean: Zeev Fraenkel

Department of Electronics. Head: David Treves
Department of Nuclear Physics. Head: Gvirol Goldring

Faculty of Chemistry. Dean: Izchak Z. Steinberg

Department of Chemical Physics. Head: Moshe Shapira
Department of Isotope Research. Head: Joel Gat
Department of Organic Chemistry. Head: Yehuda Mazur
Department of Materials Research. Head: Joost Manassen
Department of Structural Chemistry. Head: Joel L. Sussman

Faculty of Biophysics-Biochemistry. Dean: Nathan Sharon

Department of Biochemistry. Head: Shmuel Malkin
Department of Biophysics. Head: Meir Wilchek
Department of Membrane Research. Head: S. Roy Caplan
Department of Neurobiology. Head: Uriel Z. Littauer
Department of Polymer Research. Head: Zvi Kam
a. Macromolecular Physics and Chemistry
b. Macromolecular Systems of Biological Interest
c. Molecular Physiology and Cell Biology

Faculty of Biology. Dean: Michael Feldman

Department of Cell Biology. Head: Michael Feldman
Department of Chemical Immunology. Head: Sara Fuchs
Department of Genetics. Head: Leo Sachs
Department of Hormone Research. Head: Yitzhak Koch
Department of Plant Genetics. Head: Ezra Galun
Department of Virology. Head: Ernest Winocour

Feinberg Graduate School. Dean: Richard M. Hornreich

Department of Science Teaching. Head: Maxim Bruckheimer
a. Chemistry, R. Ben-Zvi
b. Mathematics, M. Bruckheimer
c. Physics, U. Ganiel

the government as well as from many individuals and organizations in the US and Europe for expansion of the facilities, which now include 35 buildings in a campus setting.

Biological research at the Weizmann Institute was formally initiated in 1950, when Professor Issac F. Berenblum of Oxford University was invited to Rehovot to develop the institute's life sciences program. At about the same time, Israeli chemists began to focus efforts on problems of biological relevance. Among those scientists were Dr. Ephraim Katzir-Katchalsky (who became the fourth president of the State of Israel) and his late brother, Aaron, also a famous scientist, who was killed in a 1972 terrorist attack.

The scientific staff today numbers about 1800 researchers, engineers, and

technicians and includes 500 scientists-in-training pursuing MSc and PhD programs at its Feinberg Graduate School. The institute members are carrying out some 640 basic and applied research projects in its 21 units, grouped administratively into five faculties: Biology, Biophysics-Biochemistry, Chemistry, Mathematics, and Physics. In addition, there is a Department of Science Teaching, which is responsible for the development of new science curricula, textbooks, TV programs, and teaching methods in the areas of mathematics, physics, and chemistry.

There are also a number of recently established centers cutting across departmental lines in fields such as aging, energy, industrial research, molecular genetics, neurosciences, theoretical physics, plant research, and structural biology.

Among the auxiliary facilities available at the institute are the Wix Central Library, which, together with departmental libraries, holds a total of 165,000 books and bound periodicals, and the Computer Center, with terminals for remote access throughout the campus.

The scientists at the Weizmann Institute have achieved an international reputation for excellence in research. After receiving the PhD degree, many graduates spend 1 to 3 years as postdoctoral fellows in the US, the UK, and Europe. Also, many scientists from other countries go to the Weizmann Institute as visiting scientists for varying periods of time. At present, there are 120 long-term visiting scientists engaged in research at the institute.

Neurobiology Research

U.Z. Littauer is head of the Department of Neurobiology, which engages in interdisciplinary projects conducted by various independent groups within the department. Recently, the institute's newly formed Center for Neurosciences and Behavioral Research, headed by Professor D. Samuel, has started coordinating all neurobiological research.

The aims of the projects of the Department of Neurobiology are the elucidation--in molecular, cellular, and sub-cellular terms--of the structure, development, function, regeneration, and plasticity of the nervous system and its components. Several systems are being used to elucidate biochemical and electrophysiological characteristics of differentiating and of mature excitable cells. These range from neoplastic cell lines of neuronal origin (neuroblastoma, pheochromocytoma) and dissociated brain, ganglion, and muscle cells cultured in

vitro, to the leech, fruit fly, goldfish, and electric fish nervous system as well as chick, rat, and calf brain. Among the properties studied are ionic channels, surface membrane components, enzymes specific to the nervous system, various receptors for neurotransmitters, and effects of neuropeptide growth factors and toxins. Molecular biology techniques are used in studies of gene expression and the cytoskeletal organization of differentiating nerve cells.

M. Schwartz is investigating why the central nervous system in higher animals does not repair itself. She has some evidence that the body may be producing factors that prevent injured nerves from sprouting anew. Her goal is identification of these growth suppression materials, which may lead to ways of interfering with their function. Use of externally applied electric currents to stimulate the repair of nerves is also under investigation.

Littauer is investigating the role of nerve cell surface glycoproteins in the development and maturation of the brain. He and his group have also been studying the structure and role of microtubule associated proteins (MAPs) during nerve cell differentiation. This was one of the first groups to report on the importance of MAPs in nervous system function.

I. Ginzburg and her group are studying the control of microtubule protein expression in the developing nervous system and are also cloning brain-specific genes. Some aspects of these studies have been carried out in collaboration with Littauer. They were the first research group to report that tubulin isoforms exist in the brain and that these isoforms are developmentally regulated. Microtubules are particularly important in the brain, where they are involved in cell differentiation and synaptic transmission.

Recently, Ginzburg et al. have isolated and sequenced two α -tubulin complementary DNA (cDNA) clones. They have also determined the nucleotide sequence of a rat brain β -tubulin. The coding region shows a high homology when compared to chicken and human β -tubulin sequences. However, the C-terminal coding end shows high divergence, and no homology is observed at the 3' noncoding regions. Three β -tubulin messenger RNA (mRNA) species have been found in rat brain. By using oligonucleotide probes, these investigators have shown that the three mRNAs are distinct species which are developmentally regulated. The specific cDNA probes and synthetic oligonucleotides are used for *in situ* hybridization studies of rat cerebellum which

show differential tubulin mRNA levels in identified cell types. Thus, these data illustrate the differential expression of the tubulin multigene family during rat brain development and suggest that there are different functions for the various tubulin isotypes.

E. Yavin and his group are engaged in several research projects in neurobiology:

1. Lipid dynamics in biological membranes, lipid alterations, and their effects on growth and function of murine neural cells.

2. Differentiation of nerve cells in culture; problems of aggregation, surface antigenicity, synaptogenesis and evolution of receptors, and drug binding; monospecific antibodies to surface receptors.

3. Neural receptors for tetanus toxin and related bioactive ligands.

Recently Yavin et al. have been emphasizing their research on the tetanus toxin. Despite preventive therapy (immunization), neonatal and adult tetanus remains a significant health problem due to the inability to reverse the course of the disease once the potent neurotoxin reaches the nervous system. This polypeptide secreted by the *Clostridium tetani* bacteria is recognized by peripheral nerves, internalized, transported intraaxonally to the central nervous system, and released at the synaptic junction of a second nerve, where it blocks neurotransmitter release. Little is known about the molecular mechanisms which internalize the toxin into the cell and translocate it through the neuronal membrane. To elucidate these aspects of transport and mechanism of action at the molecular level, highly homogeneous tetanus toxin preparations are necessary. Such preparations have not previously been obtained, but recently Yavin et al. have succeeded in preparing a highly purified toxin fraction which can be separated into two distinct (A and B) forms. These investigations are now focusing on the following: (1) biophysical, immunological, and toxicological characterization of the A and B forms of tetanus toxin, and (2) pharmacological characterization and mutual interaction of these purified forms with respect to target tissue, receptor identification, axonal transport, and mechanism of inhibition of transmitter release.

H. Soreq and her group have several research projects, such as: (1) molecular cloning of the human genes encoding nervous system acetylcholine esterase; (2) expression of brain mRNAs in *xenopus* oocytes; (3) control of gene expression

during the development of rodent cerebellum; and (3) selective alterations of gene expression in primary brain tumors. The excellent research studies of H. Soreq et al. have led to international recognition of their work.

I. Gozes and her group in the Department of Hormone Research are studying the molecular aspects of endocrinology, including gene cloning and control of expression of regulatory peptides which serve both as neurotransmitters and hormones.

One of the research projects carried out by this group is a study of the vasactive intestinal peptide (VIP), which has been found to act as both a neurotransmitter and hormone. This polypeptide appears to be involved in a wide variety of biological activities, and increasing evidence points to its importance as a mediator or modulator of several basic functions in different organs; for example, it can modulate the activity of other neurotransmitters in the brain and could be a major factor in cardiac activity and respiration. The multiple actions of VIP are correlated with its widespread distribution throughout the body. VIP is found in both endocrine and nerve cells in the parasympathetic ganglia and in the brain, where it has a discrete regional distribution. The highest levels of VIP are found in the cerebral cortex, hypothalamus, amygdala, hippocampus, and corpus striatum. It is also found in the placenta, adrenal medulla, mast cells, and platelets.

The previous work of Gozes et al. dealt with the distribution, abundance, and physiological roles of VIP as well as PHM-27, a peptide that is closely related in sequence and activity to VIP. These investigators have also established the primary structure of part of the VIP gene by molecular cloning and DNA sequence analysis. Their finding that VIP and PHM-27 coding sequences are located on two separate exons of the human genome and the homology of their 3' splice site is indicative of alternative RNA splicing. Using their molecular probes, Gozes et al. are now investigating the regulation of the VIP genes, including the effect of steroid hormones.

Several other groups have undertaken in-depth studies of neurological diseases. S. Fuchs and R. Arnon and their coworkers in the clinical immunology department, for example, specialize in the immunological aspects of the nervous system and, in particular, the causes and possible cures of neuromuscular diseases such as myasthenia gravis and multiple sclerosis.

In the Department of Virology, S. Rosenblatt and E. Winocour are investigating the biology of the measles virus, seriously implicated in subacute sclerosing panencephalitis, a fatal nervous disorder that afflicts children. Their aim is the development of a model system for studying how certain viruses that initially cause relatively harmless though acute infections can be dormant in the body, only to reappear years or even decades later, causing a life-threatening degenerative disease.

Although there are many other important and interesting research projects in neurobiology at the Weizmann Institute, it is not possible to cover everything in this article. Therefore, this section has dealt with selected topics to give the reader some idea of the extensive research in neurobiology.

Parasitology Research

The curbing of parasitic disease is a biomedical research project which would benefit tens of millions of people throughout the Third World. To accomplish this aim, researchers must investigate the complex life cycles of parasitic single-celled animals and worms that follow a sophisticated, preprogrammed life scenario in order to survive in their environment, thereby reaching new victims. Malaria, for example, requires a specific mosquito to transmit the infection, while other parasites take advantage of a particular sand fly or even a special snail to pass on the disease. By studying the various forms a pathogen takes in each of its hosts, new ways of thwarting it can be defined and implemented.

In the Weizmann Institute's Parasitic Disease Unit, organisms causing two serious illnesses are undergoing intensive study. They are *Entamoeba histolytica*, responsible for amoebic dysentery, and the snail-borne worm schistosoma, which produces bilharzia (schistosomiasis), an infection particularly common in Egypt that has afflicted millions since prehistoric times. R. Arnon of the Department of Chemical Immunology is examining ways of producing antibodies that can be used to attack the schistosoma parasite and is investigating the possibility of designing a bilharzia vaccine based on dead cercariae (the free-swimming form of the worm in polluted waters), or on material isolated from other stages of the multiform life cycle of schistosoma. I. Schechter of the Department of Immunology is engaged in the identification, characterization, and molecular cloning of schistosome antigens with increased potential for protective immunity.

Research into amoebas has already provided important new approaches for improving treatment of amoebic dysentery. C. Gitler (Department of Membrane Research) has discovered an amoeba-produced toxin that enables the parasite to damage intestinal and other tissues. With this protein, it may now be possible to design a vaccine that offers protection against the amoeba, similar to the way that modified tetanus toxin is used to protect against damage by that bacterium. In another approach, D. Mirelman (Department of Biophysics) has shown how certain relatively nontoxic antifungal agents prevent amoebas from forming the protective cyst coating that allows them to survive outside the body in polluted water systems. Using such agents in combination with standard anti-amoeba chemotherapy might improve treatment of dysentery and, at the same time, help prevent the disease from spreading. Mirelman and his group are also closely examining ways of eliminating the severe toxic side effects of anti-amoeba drugs presently in use.

Immunology Research

The mechanisms of immune system action are under intense study--from the ways that lymphoid cells recognize foreign agents, to the mechanisms governing their activities, and their operation in destroying threatening materials.

In the Department of Cell Biology, for example, G. Berke is closely probing the way immune system cells attack and destroy foreign tissues, as is commonly observed in the rejection of organ transplants. He believes he has uncovered the underlying principle used by one important component of the immune system, T lymphocytes, to kill transplanted cells. Knowledge of this mechanism may provide a basis for the design of more specific and less toxic ways of interfering with immune system rejection of organ transplants.

Researchers at the institute are interested in stimulating immune defenses to help the body overcome disease. For example, Pasteur's idea of vaccination against smallpox was based on this concept. M. Sela and R. Arnon are working on making vaccinations safer and easier to prepare. Using small, synthetically produced fragments of viruses or bacteria linked to special carriers, they have been able to induce immunity against disease without recourse to the weakened or dead viruses used in standard vaccines. They have already applied such "synthetic vaccines" to protect animals against influenza, diphtheria, and cholera.

The immune system sometimes goes awry and starts making a large population of cells which attack "self" rather than foreign antigens. Such conditions, known as autoimmune diseases, include arthritis, multiple sclerosis, and myasthenia gravis. I. Cohen and coworkers at the institute's Department of Cell Biology have isolated, for the first time, and grown in tissue culture the T lymphocytes responsible for the appearance in animals of three autoimmune conditions similar to multiple sclerosis, autoimmune thyroiditis, and arthritis in man. In all these cases, Cohen et al. have been able to neutralize these cells and use them in a therapeutic program to entirely prevent their appearance. These researchers are now looking for such cells in patients suffering from autoimmune disease with the aim of their possible use in controlling these often-crippling diseases.

Cancer Research

Cancer research at the Weizmann Institute involves major research projects in genetics, cellular biology, membrane research, and immunology. Cancer-related studies are carried out in several departments at the institute. The scope of these projects is very broad, so only some of the aspects will be presented.

L. Sachs, head of the Department of Genetics, is one of the institute's best known cancer researchers. He first demonstrated *in vitro* that certain cancerous cells, including leukemic cells, could be transformed back into normal cells. He has recently shown that such transformations can also be accomplished in animals. Sachs and his group have also developed a promising new approach to the study of the surface membranes of both normal and cancerous cells, demonstrating that myeloid leukemia both in animals and in humans with identical clinical patterns may be produced by different biological irregularities--a finding that should facilitate diagnosis and treatment of leukemia.

Other areas of leukemia research are being pursued by Dr. Haron-Ghera and coworkers at the institute's Department of Chemical Immunology. They have developed experimental techniques for producing major types of leukemia in a single strain of mice. These techniques have resulted in new studies of blood cancers and the production of animal malignancies more similar to human varieties than those previously available. Haron-Ghera et al. have demonstrated, for example, that leukemias develop in two stages in mice: an initial stage involving a transformation into preleukemic cells, and a secondary stage where

cells start to multiply wildly. However, this latter proliferation step does not occur in all mice. Haran-Gara and her coworkers are, therefore, investigating immunological and other factors that work to keep preleukemia in check.

Research on the relationship between immunology and cancer is a central interest of two other ranking institute immunologists, institute President M. Sela and M. Feldman, head of the Department of Cell Biology. Although a major clinical problem in human cancer research has to do with metastasis (the development of secondary tumors), this field has been largely neglected--primarily because most tumors induced in ordinary lab mice do not spread from the site of initiation. Recent immunological studies carried out by Feldman and his colleagues on metastatic mouse tumors indicate that the surface properties of metastatic cells differ from those of primary tumor cells. This finding could result in fresh immunological approaches to the problem of metastasis. There is already an indication of what processes may operate in the conversion of nonmetastatic to metastatic tumor cells. For example, fusion of a cancer cell with certain normal cells may enable the cancer cell to generate metastatic growths. Feldman et al. have shown that a primary tumor growth exerts an inhibitory effect on the growth of metastases. Understanding this inhibitory effect may lead to development of effective tools for controlling the spread of cancer.

Sela, together with R. Arnon and their coworkers, are examining other immunological approaches to cancer detection. It has been shown that certain specific malignancies (cancer of the colon, for instance) are characterized by the presence of a protein (known as the carcino-embryonic antigen) in the patient's blood. Using a synthetic approach in combination with hybridoma biotechnology, these researchers have produced a monoclonal antibody for use in detecting this antigen in blood, an advance that may be of value in the diagnosis and prognosis of malignancies characterized by carcino-embryonic antigen release. In addition, institute immunologists are developing what they term "guided missiles"--combinations of antibodies and anticancer drugs that deliver potent agents directly and specifically to cancerous tissue, thus substantially stepping up effectiveness while reducing potentially dangerous side effects.

N. Trainin (Department of Cell Biology) is using yet another approach in cancer research. He and his group are

studying the thymus, a gland vital to the immunological defenses. The removal of the gland can lead to heightened susceptibility to certain cancers and infections. An extract obtained from the thymus gland called THF (thymic humoral factor) has been shown to enhance the body's fight against disease. A pilot plant has already been set up to produce relatively large quantities of THF (from calves) for use in clinical trials. THF is already being used in combined therapies to control leukemia.

Two other therapeutic approaches under study at the institute are now undergoing clinical testing. In one of them, M. Shinitzky (Department of Membrane Research) has shown how to stimulate the immune system to recognize tumor cells, and it is hoped thereby to destroy these cancerous cells. The development is currently being tested on patients in the US. Also under clinical study is a combination of microwave heating and either hormonal or radiation therapy, designed by A. Yerushalmi for treatment of cancer of the prostate gland.

The environmental triggers of cancer also are under investigation at the institute. Professor Emeritus I. Berenblum, best known as the developer of the two-stage theory explaining the appearance of tumors, is beginning to explore the role of tumor promoters--those chemicals that, while not themselves tumor producers, enhance cancer induction by known carcinogens. This work on the chemical triggering of cancer may provide the clues necessary to stop the triggering altogether. In a related development, S. Lavi (Department of Virology) has designed an improved tissue culture system for use in testing chemicals suspected of causing malignancies. This tool should be of use to scientists and regulatory agencies in assessing the possible hazards of various environmental and industrial materials.

Some cancers are caused by viruses, certainly in animals and, it appears likely, in man as well. E. Winocour (Department of Virology) is involved in deciphering the intricate mechanism by which tumor viruses attack a cell's genetic apparatus and cause the transformation to malignancy. While his work can help us understand a fundamental cancer-initiating mechanism, its implications are even more significant. Since tumor viruses are able to implant their own genetic material within a cell under attack and thereby alter its biochemistry, the possibility exists that when scientists know precisely how this is attained, they may be able to use viruses for introducing favorable genetic

changes into cells and even to overcome certain genetic diseases.

The biochemical modifications caused by tumor viruses and the exact location of their integration into the cell's genetic apparatus are focal points of research under way in the Department of Genetics by Y. Aloni, M. Fogel, and L. Sachs. The studies on such viruses by these investigators were the first to show that the opposite process can occur--i.e., that DNA tumor viruses can incorporate genes from a cell into their own genetic complement. Related work by D. Givol and E. Canaani (Department of Chemical Immunology) pinpoints specific changes induced by carcinogens in a particular gene that will produce a cancerous transformation in a cell.

Another development, concerned with early tumor detection, comes from the laboratories of Professor Emeritus E.H. Frei, former head of the Department of Electronics. Two techniques for this kind of early discovery and diagnosis are being tested in an attempt to improve and streamline present-day screening methods. One of these approaches measures the electric properties of breast tissue, the other tests the tissue's viscoelasticity or resiliency. The former device, known commercially as the Mammoscan Electronic Breast Scanner, is undergoing testing on thousands of women in Israel and Europe.

Research on Burn, Wound, and Fracture Healing

In treating severe burns over large areas of the body, doctors give highest priority to the prevention of infection and life-endangering loss of body fluids and proteins. To surmount these dangers, skin transplants are used to cover and protect burn surfaces, even though these transplants are almost invariably rejected by the body within a few days.

Chemical immunologist I. Schechter has developed a special chemical treatment (glutaraldehyde-treated skin homografts) aimed at delaying this rejection and thus allowing protective skin coverings to remain in place longer (Schechter et al., 1975). The institute-developed technique, first tried successfully on animals, has been used with promising results by the Israeli Defense Forces and is now being incorporated into routine treatment of chemically infected wounds and surgical procedures that involve the removal of large patches of skin.

In related work, scientists in the Department of Membrane Research are studying the process of wound healing, developing techniques to accelerate tissue repair. They have found that by

treating wounds with glucan (a carbohydrate), healing time in animals can be cut in half. Glucan is now being tried on patients, particularly for postoperative care of surgical incisions.

Orthopedic problems are also being addressed. S. Edelstein of the Department of Biochemistry, for example, has shown that a particular vitamin D derivative can be used routinely for treating the bone weakness known as oteomalacia, an affliction that often appears in patients with kidney problems. He is now testing a related derivative that may speed up the mending of bone fractures. Prosthesis devices for orthopedic and ear surgery are under development in the Department of Plastics Research.

Genetics Research

At the Weizmann Institute, researchers have long been occupied with finding out exactly how genetic information is selectively translated into the chemicals necessary for forming and sustaining body tissue. Basic work in this area is carried out in eight departments. Several years ago, Y. Aloni, S. Lavi, and Y. Groner demonstrated the existence of a "split gene," an important development that has helped in understanding the intricate workings of the genetic machinery. They are continuing to explore the complex molecular events that control the expression of genetic traits.

Other institute scientists are closely examining the nature of genetic disease. In the Department of Genetics, for example, L. Sachs' early development of prenatal diagnosis via examination of amniotic fluid cells of a fetus has today been expanded by others to provide a standard method of screening for hereditary diseases, including Downs syndrome (mongolism) and Tay-Sachs disease.

D. Yaffe (Department of Cell Biology) is studying the hereditary disease muscular dystrophy. He has developed a system for isolating and growing pure cultures of muscle-forming cells taken from dystrophic mice. In cultures, these cells develop into muscle fibers able to contract and express other biochemical and physiological characteristics of muscle tissue. Yaffe is using his system to identify the molecular basis of the biological defect responsible for this severe muscle-wasting disease.

Synthetic chemical research carried out at the Department of Organic Chemistry by D. Shapiro in cooperation with US scientists has led to new information on three rare genetic afflictions: Gauchers, Niemann-Pick, and Fabry's diseases. Supplies of reagents available only from

Shapiro's laboratories at the Weizmann Institute have already led to diagnostic tests for Niemann-Pick and Gauchers diseases, both debilitating illnesses characterized by faulty lipoprotein metabolism. These have also enabled isolation of an enzyme, the absence of which is responsible for Gauchers Disease and that may eventually be used for treatment. Attempts are now under way to produce it in quantities large enough for therapeutic use.

Other extensive projects in biomedical research are also being carried out at the Weizmann Institute. These include work on heart disease and stroke, aging, drug addiction, reproduction and birth, and research on the trapping of airborne substances (bacteria, dirt, smog, etc.) by the body's natural clearing mechanisms and defects in this mechanism (e.g., cystic fibrosis).

Conclusion

Since its inception in 1949, the Weizmann Institute has become an internationally recognized center for scientific research. The institute is especially known for its biological/biomedical research. Major contributions have been made by the scientists in basic research as well as in applied research resulting in several patents and collaborations with US and European scientists and industrial companies.

Reference

Schechter, I., A. Bellshegrin, M. Ben-Basat, and I. Kaplan, "Prolonged Retention of Gluteraldehyde-Treated Skin Homografts in Humans," *British Journal of Plastic Surgery*, 28 (1975), 198.

10/10/85

Chemistry

IUPAC INTERNATIONAL SYMPOSIUM ON MACROMOLECULES

by Oh-Kil Kim. Dr. Kim is a researcher in the Chemistry Division, Naval Research Laboratory, Washington, DC.

The International Union of Pure and Applied Chemistry (IUPAC) held the 30th

International Symposium on Macromolecules at The Hague, The Netherlands, from 18 through 23 August 1985. The topics of the microsymposia were water-soluble polymers, reactive polymers, polymers at interfaces, engineering materials, (di)electric properties, and general aspects. This article covers some interesting topics in electric properties, particularly conducting polymers, that were discussed at the symposium.

In his invited lecture, Professor Wegner (University of Mainz, West Germany) reviewed recent polymer research, focusing on important structural factors for polymer conductivity. He stressed the solid state feature common to graphite and organic metals: layered, oriented, and stacked structures. Such structural requirements should be equally effective in conducting polymers to promote a charge-transfer interaction with doping agents. A fully oriented crystalline polyacetylene can form such a structure (Leising, 1984). Wegner clearly suggested the synthetic importance of so-called one-dimensional graphite. Another polymer structure that shows unusually high conductivity is that having heterocyclic conjugated ladders (Kim, 1985).

The emphasis in polymer research seems to be on processability. Most conducting polymers cannot be processed after the conducting structure is prepared. One approach is to first process an insulating soluble precursor, then convert it into a conjugate structure. Interestingly, two different groups (Murase et al., 1984, and Gagnon et al., 1984) used this approach to synthesize poly(p-phenylene vinylene), PPV, via pyrolysis of the soluble precursor polymer (I) under an inert atmosphere:

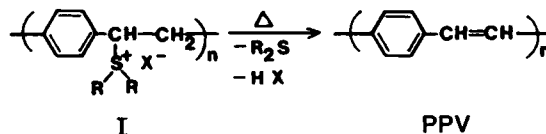

A highly oriented and flexible film of PPV can be obtained by thermal treatment and stretching of the precursor. With a draw ratio of 10 and high temperatures, an extremely high conductivity (2500 S/cm) was attained in this material after AsF₅ doping. However, PPV samples made by different routes are known to be insoluble powders. An important suggestion from this finding is that even with the same chemical structure, variations in the synthetic conditions change the morphology, orientation, and

purity of the polymer. These, in turn, control the polymer conductivity. Unfortunately, the doped PPV lacks stability under ambient conditions.

The stability of conducting polymers was investigated with respect to doping method and doping species (Osterholm and Passiniemi, unpublished). A pristine film of polythiophene (PT) prepared electrochemically in the presence of BF_4^- or ClO_4^- ions is not very stable; the sensitivity of PT to air and moisture is particularly great when the anion is BF_4^- . However, when the anion is converted to FeCl_4^- from BF_4^- by chemical doping after the PT is neutralized, the polymer stability is noticeably increased; the conductivity decrease is only 10 percent over a 7-month period in ambient conditions. The reason for the improved stability is unclear, but it may be related to differences in binding interaction between polymer and dopant ions and also in the reactivity of dopant ions toward air and water.

A significant breakthrough was reported in the development (Jasne and Chicklis, unpublished) of processability and stability of conducting poly(pyrrole) (PP). The feature of this system is to electrochemically polymerize pyrrole in the presence of a polymeric anion (polymers and copolymers of polyacrylate salt latex) rather than an inorganic or organic anion. The total pyrrole content in the PP-latex complex can be varied 2 to 30 percent by weight to give conductivities of 10^{-3} to 1 S/cm and good stability. This polymer is soluble in organic solvents, and the cast films are optically transmissive.

While research on the structure and conductivity of electroactive polymers continue, increasing attention is being paid to the problems of stability and the processability of conducting polymers.

References

- Gagnon, O.R., J.D. Capistran, F. Karasz, and R.W. Lenz, *Polymer Preprints*, 25 (1984), 284.
- Jasne, S., and C.K. Chicklis (Polaroid Corporation, US), unpublished.
- Kim, Oh-Kil, *Journal of Polymer Science, Polymer Letters Edition*, 23 (1985), 137-139.
- Leising, G., *Polymer Bulletin*, 11 (1984), 401.
- Murase, I., T. Ohnishi, T. Noguchi, and M. Hirooka, *Polymer Communications*, 25 (Guildford, 1984), 327-329.
- Osterholm, J., and P. Passiniemi (Nestle Oy Research Center, Finland), unpublished.

10/29/85

MASS SPECTROMETRY MEETINGS HELD IN WALES AND WEST GERMANY

by Mark M. Ross, Joseph E. Campana, and David A. Kidwell. Drs. Ross and Kidwell are researchers in the Chemistry Division, Naval Research Laboratory, Washington, DC; Dr. Campana is at the Environmental Research Center, University of Nevada, Las Vegas.

Two meetings dealing with mass spectrometry were held in Europe last September: the 10th International Mass Spectrometry Conference and the Third International Workshop on Ion Formation From Organic Solids. This article covers highlights of both meetings.

10th International Mass Spectrometry Conference

The 10th (Triennial) International Mass Spectrometry Conference was held in Swansea, Wales, from 9 through 13 September 1985 at the University College of Swansea. The complete proceedings containing the almost 600 papers, including five plenary and 28 keynote lectures presented at the meeting, will be published in early 1986 as a two-volume set in the *Advances in Mass Spectrometry* series edited by Professor J.F.J. Todd (University of Kent) and published by John Wiley and Sons, Ltd.

The conference organizing committee was chaired by one of the fathers of modern mass spectrometry, Professor John H. Beynon, and the meeting was held in his honor in Swansea, where he heads a Royal Society Research Unit at University College. Over 1000 delegates from almost 40 countries attended the conference. The US was well represented with over 125 delegates, second only to the 250 delegates from the UK.

Three years ago, we reported the extreme interest in the new technique of fast-atom bombardment mass spectrometry (FABMS) at the last international meeting (ESN 37-2:58-59 [1983]). FABMS has become a popular method for analyzing thermally labile compounds. FABMS is categorized as a desorption ionization technique, along with secondary ion mass spectrometry (SIMS), laser-desorption mass spectrometry (LDMS), and Californium-252 plasma-desorption mass spectrometry (PDMS). This category of desorption ionization was one of the prime areas of emphasis in this conference. Another area of interest was theory, interfacial, and applications of the combination of high-performance liquid chromatography with mass spectrometry (LC/MS). This method offers much promise for analyzing complex mixtures of intractable

and labile molecules (drugs, metabolites, biochemicals) and macromolecules, especially with the recent developments in mass spectrometry, including high field magnets for higher mass range, and higher sensitivity instruments. Many of the presentations were on the thermospray sample introduction/ionization technique, but there is still interest in the direct liquid injection, electrospray, and moving-belt interface techniques. However, the older sister technique, gas chromatography (GC)/MS, maintained an important position in the conference presentations.

Photodissociation techniques also were well represented. In photodissociation, a laser is used to excite a functional group of an ion, which then fragments. This technique offers high selectivity in the fragmentation process. In addition, lasers may be used to photoionize molecules and atoms. By selecting appropriate wavelengths of the laser light, one may achieve selective ionization. Also, the use of lasers to study the spectroscopy of ionic species in photodissociation experiments was emphasized.

An oral session and a poster session were devoted to cluster ions, and we predict a tremendous growth in this area by the time of the next international conference (to be held in Bordeaux). Other traditional areas of importance remained--ion structure determination, instrumentation, and physical and theoretical aspects. All desorption ionization techniques have been applied to the analysis of biomolecules such as drugs, proteins, and carbohydrates. However, most of the soft desorption techniques give only molecular weight information and little structural information due to the paucity of fragmentation. Increasingly, researchers are turning to MS/MS techniques to provide this structural information. In an MS/MS experiment, the molecular ion is selected by the first mass spectrometer and fragmented by collision with a gas; the fragments are analyzed by the second mass spectrometer. There are 16 possible MS/MS instruments resulting from the combinations of the four basic types of mass spectrometers: quadrupole, magnetic, electrostatic, and time-of-flight (TOF). Most of these were described at the conference. From the spectra presented, the higher collision energy provided by magnetic and TOF instruments gave the most useful information for the structural analysis of proteins and carbohydrates. However, because no technique provided complete structural information, further work in this area is needed.

Although singling out a few papers of merit in a conference of this size is unfair, several topics may be of interest. Gynther (University of Kuopio, Finland) studied the fragmentation of several carbolines. These compounds have been proposed to arise from reaction of acetaldehyde with tryptamine derivatives and are elevated during alcohol consumption. Carbolines may be addictive, and this addiction could be the cause of alcoholism. Carr (Smith, Kline, and French, US) showed that MS/MS can be used to deduce the structures of carbohydrates, but only if they are first permethylated. Carbohydrates are the antigenic determinants of blood cells, are important in cell-cell communication and adhesion, and are used to tag proteins that are to be excreted from cells. McLafferty (Cornell University, US) and Yost (University of Florida, US) showed how MS/MS may be used for the rapid determination of the structure of an unknown drug and for the identification of its metabolites. This technique should find wide usage in any large-scale drug screening program.

The conference featured an instrument exhibition with a large number of operating mass spectrometers on display. Major developments include the increasing availability of commercial LC/MS systems. One company announced a research-grade ion trap detector system for fundamental instrumentation and ion chemistry research. In addition to a simple GC detector, new operating modes for this instrument for the study of ion/molecule reactions were demonstrated. Another company introduced a relatively low-cost, medium-performance tandem mass spectrometer. This instrument is apparently so revolutionary that the sector analyzers were enclosed so the instrument geometry could not be determined by viewers. The tandem MS technique, like FABMS, is now very commonplace.

IFOS III

The Third International Workshop on Ion Formation From Organic Solids (IFOS III) was held at the Physikalisches Institut der Universität Münster, West Germany, from 16 through 18 September 1985. The workshop was organized by Professor A. Benninghoven and Dr. W. Sichter mann of the University of Münster, and it was sponsored by the German Research Society (Deutsche Forschungsgemeinschaft) and numerous instrument companies.

The purpose of the workshop was to bring together scientists who study or use desorption ionization mass spectrometry (DIMS)--which includes SIMS,

FABMS, PDMS, and LDMS--to discuss many aspects of secondary particle ionization and emission processes. The workshop was attended by more than 80 participants representing nine countries. There were 42 presentations, over 40 percent of which were given by scientists from the US. The meeting schedule also allowed for lengthy discussion periods after each presentation and at coffee and lunch breaks, which enhanced fruitful exchanges of ideas. A book containing the written versions of the presentations at IFOS III will be published by Springer-Verlag in early 1986.

The sessions were divided according to DIMS methods: PDMS, SIMS, FABMS, and LDMS. In addition, there was a session on instrumentation and another on the use of Fourier transform MS in DIMS studies. Finally, there was a panel discussion on instrumentation, which was the last activity of the workshop.

Several topics were common to many of the presentations at IFOS III. The first area of interest to many of the participants was optimization of sample preparation techniques for DIMS studies. Professor R.D. Macfarlane (Texas A&M University, US) discussed the use of the polymer surfaces that allowed specific adsorption of sample molecules. In addition, Dr. B. Sundqvist (University of Uppsala, Sweden) discussed some experiments in which nitrocellulose was used as a substrate for various large biological compounds to promote the production of multiply charged ions. Finally, M.M. Ross and D.A. Kidwell (Naval Research Laboratory, US) presented results of studies using derivatization/SIMS, in which analyte species of interest (e.g., drug compounds in urine) are derivatized to form preformed ions resulting in enhanced sensitivity (picogram levels) of SIMS analyses.

The second area of common interest was presented initially in Benninghoven's opening remarks. He stressed the need for researchers in the DIMS area to be consistent in using terminology and reporting sputter yields (total species removed/total incident primary particles) and secondary ion yields (total secondary ions/total incident primary particles). Several presentations reported data on these yields, including those of Professor D.F. Barofsky (Oregon State University, US) and Professor F.W. Rollgen (University of Bonn, West Germany). The sputter yield for glycerol was reported to be approximately 600.

Neutral yields are much greater than ion yields for most organic compounds. Therefore, it is of interest to increase ion yields either by increasing sample ionization efficiencies (second-

ary molecular ions/sample molecules deposited), or by postdesorption ionization of sputtered neutrals. The derivatization/SIMS studies of Ross and Kidwell and the reported improved sample preparation methods served as examples of attempts to increase sample ionization efficiencies. J.E. Campana (University of Nevada, US) reported on the use of a novel chemical ionization/fast-atom bombardment (CI/FAB) ion source to ionize sputtered neutrals. The CI/FAB technique allowed an increase of almost three orders of magnitude in the abundance of the protonated molecule $(M+H)^+$ of various neat samples.

The third major topic was that of the applications of DIMS methods to analyses of many different types of compounds. Researchers at Münster presented results of studies of polymers, peptides, and proteins using a newly constructed TOF SIMS instrument. Impressive sensitivities (less than 1 femtomole) for large molecules were shown. Professor C.C. Fenselau (Johns Hopkins University, US) discussed results of FABMS applied to analyses of compounds with molecular weights greater than 5000 amu (e.g., porcine insulin). Analyses of compounds with molecular weights greater than 10,000 amu (e.g., porcine trypsin and phospholipase A₂) were presented by Dr. B. Sundqvist using heavy ion-induced desorption. Dr. R. Cotter (Johns Hopkins University, US) gave results that showed the advantages of pulsed TOF measurements, which use an acceleration pulse rather than a continuous field. This allows a variable delay between ion production and analysis which may be used to eliminate metastable decompositions and improve spectral resolution.

The final common theme at IFOS III was instrumentation developments. In addition to relatively recent reports of DIMS studies using Fourier transform MS with cesium ion bombardment or laser desorption, there were numerous presentations of TOF/SIMS studies. Specifically, metastable ion studies were reported by Professor K. Standing (University of Manitoba, Canada) and by Professor Y. LeBeyec (Institut de Physique Nucléaire, Université Paris Sud, France) using a deflector and an off-axis detector to separate the ionic and neutral components of the beam. Professor H. Wollnik (University of Giessen, West Germany) presented a mathematical treatment in modeling for the development of TOF mass spectrometers. He concluded that an ion microscope would serve as a good model for a TOF instrument. Dr. E. Niehuis (University of Münster, West Germany) described the new TOF/SIMS

recently built at Münster. This instrument is a reflectron (3 degrees) TOF, capable of resolving powers greater than 6000. The inherent advantage of a TOF instrument is high transmission (10 to 50 percent), and most efforts are directed toward improved resolving powers or metastable ion studies. Dr. R.E. Honig (RCA Laboratories, US) described a unique SIMS instrument that will allow analysis of sputtered ions by a TOF or a triple stage quadrupole mass spectrometer.

In summary, IFOS III was a well-organized and successful workshop that provided a unique opportunity for discussions among scientists from the various fields of desorption ionization mass spectrometry.

10/29/85

Engineering

AUTOMATION AND ROBOTIZATION IN THE WELDING INDUSTRY

by Kenneth L. Challenger. Dr. Challenger is the Liaison Scientist for Materials Science in Europe and the Middle East for the Office of Naval Research's London Branch Office. He is on leave until May 1986 from the Naval Postgraduate School, where he is Associate Professor of Materials Science.

This article summarizes the Portevin Lecture presented by Professor F. Eichhorn during the annual assembly of the International Institution of Welding (IIW) held in Strasbourg, France, from 2 through 6 September 1985. I believe that Eichhorn's observations and conclusions regarding the existing problems associated with robotization of industry and the possible side effects of robotization are very perceptive and timely. (Eichhorn's own research was the subject of *ESN* 39-4:149-152[1985]. A future *ESN* article will discuss the activities of the IIW's Commission IX, Behavior of Metals Subjected to Welding.)

Printed copies of the complete lecture can be obtained by writing to Eichhorn at Institut für Schweisstechnische Fertigungsverfahren der Rheinisch-Westfälischen, Technischen Hochschule Aachen, Pontstrasse 49, 5100 Aachen, West Germany. I recommend the lecture as required reading for anyone involved

in the design, research, or development of welding equipment. But perhaps a more important aspect of his lecture is that he stepped back from the technical details and assessed how Japan, Europe, and the US are integrating robotics into their industries; he then discussed some sociological implications of this change in industry.

The following sections present the highlights of Eichhorn's lecture; in addition, I offer my own comments about the issues raised.

Background

The welding industry, Eichhorn said, is a prime candidate for robotization and automation because: (1) many of the tasks performed by welders are dangerous and tedious; (2) labor is a very large portion of welding costs, and the cost of labor is rising rapidly; (3) the supply of skilled welders is decreasing; and (4) more consumable material is used by manual welding than by automatic welding.

An accepted fact is that the welding industry will become increasingly automated; at present, two factors are limiting the rate of this change: first, the present equipment has limitations in the area of adaptive control capabilities, and second, the capital cost is high. Another factor, emphasized by Eichhorn but not yet affecting the rate of robotization, may become the largest problem resulting from this change in industry: the sociological problem of what to do with all of the free time that robotization will create (a labor force that is unemployed or working fewer hours per week).

It is clear to me that the technical problems are under study, and progress has been rapid. But what is being done about the fundamental social problem? In my opinion this should be a national concern, perhaps more so in Europe than in the US, because Europe's use of industrial robots is increasing much faster than ours.

Technical Problems

Completely replacing a skilled welder with a robot will not occur in the near future, Eichhorn said. Robotization would not occur to any great extent at all without the recent developments in microelectronics and microprocessors. The main reason is that present technology is still a long way from being capable of building a sensing and control system for the robot that is comparable to the human's. Welders use sight, hearing, and touch to provide sensory input to the brain; when this information is processed, the hand

alters the position of the welding heat source. The rate at which data can be collected and analyzed and the appropriate changes made is phenomenal. The adaptive control systems (ability to react to disruptions or changes during welding) of existing welding equipment are rapidly improving, but gaps in their development exist, and even when these gaps are filled they will still not approach the capabilities of a human to provide adaptive control. (For a thorough review of this topic, see ONR, London, report C-5-84, "ONR, London, Workshop on Robotics," by J.F. Blackburn and S.Y. Harmon.) Thus, some welding applications will always require a skilled human to perform the task. The major equipment problems today are with the sensing systems and the design of the overall operational model for the control system. The power supplies are developed to a very advanced stage and are capable of meeting all of the required conditions (the kinetics of regulating the power supply--i.e., the speed at which the welding parameters can be altered).

The existing robots themselves present some serious problems. Most of them have been designed to perform manipulative functions where five or six axes of rotation are sufficient. However, arc welding often requires more axes of rotation than this for the robot to follow the weld joint.

Eichhorn mentioned that to solve these technical problems, the welder, the robot designer, and the software designer must work much closer together than they do at present.

World Trends in Robotization

Eichhorn has collected some very interesting data on the rate of robotization. As mentioned before, the cost of labor is one of the major incentives to automate. Figure 1 presents a comparison of average hourly labor costs for several countries. From this viewpoint, the US, West Germany, and Switzerland have the most incentive to automate and Japan comparatively little incentive. But in reality this does not seem to have a major effect. In Figure 2 we see that Japan has more robots in use than any other country. This difference in robotization among the countries considered is even more dramatic when the size of the work force is considered. With this in mind, it is surprising that Sweden uses more robots than any other country (18.8 robots per 10,000 employees, while the US only uses 3.7 robots per 10,000 employees). If we compare the combined European workforce, we find that in 1983 a similar use of robots exists in the US and Europe. However, Europe is introducing robots into its industry at a much more rapid pace than is occurring in the US. The number of robots in Europe increased 3.5 times between 1980 and 1983, while in the US the increase was less than a factor of 2.

Japan is using more robots than the US today, and the projected use of robots in Japan is much greater than in the US. The increase in robotization in Japan is expected to match that in Europe. A breakdown of the jobs performed by robots will clearly indicate which sectors of the labor force will be more

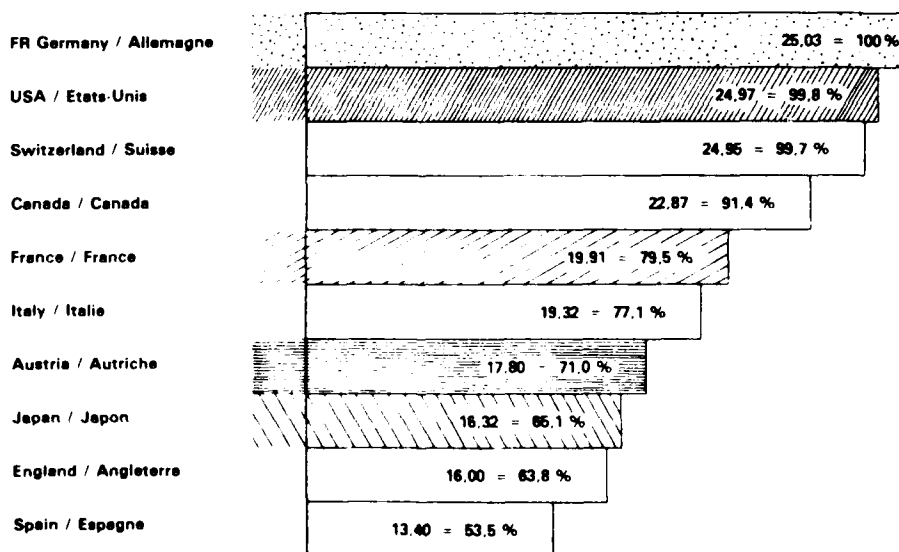

Figure 1. General costs per hour in industry, 1981 (Eichhorn, 1985).

affected. Eichhorn only had these data for West Germany (Figure 3). The functions of the robots are divided into two categories: tool positioning and part positioning. The total use of robots for welding is difficult to estimate from

this as some of the part manipulating robots are no doubt involved in welding operations. However, one can see that seam and spot welding represents the major use of robots in West German industries. The robots used for seam

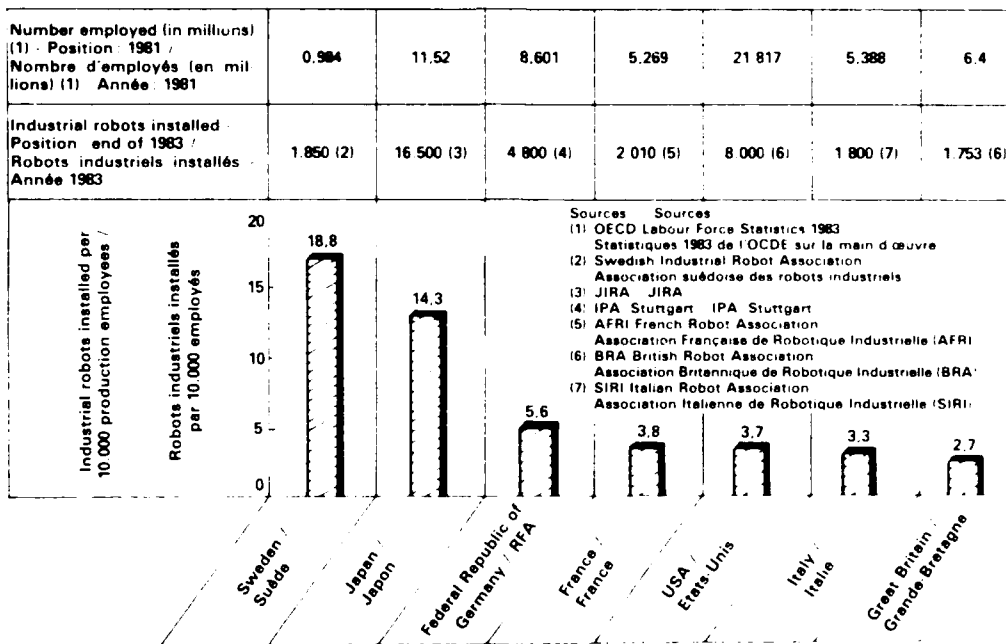

Figure 2. Penetration of industrial robots in some selected countries (Eichhorn, 1985).

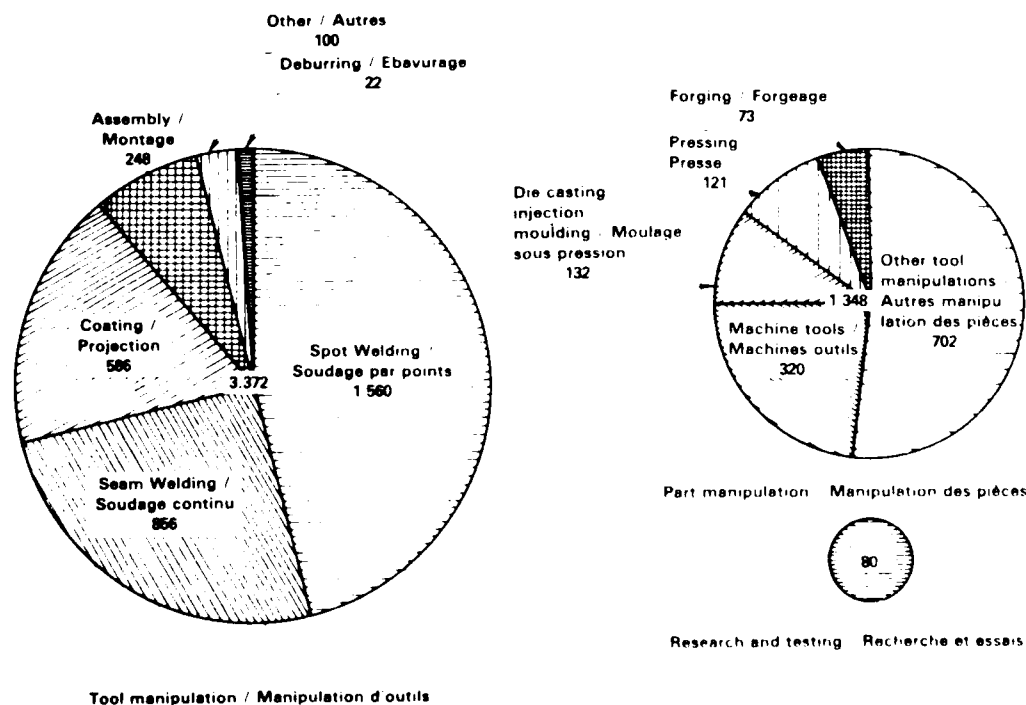

Figure 3. Operations where industrial robots are in use in West Germany, 1983 (Eichhorn, 1985).

welding have, in general, been developed for part manipulation and thus are not ideal for welding. This problem is slowly being solved by the robot fabricators, who are designing robots to meet the specific needs of seam welding. These purpose-built robots, combined with the rapid development of sensors, will result in an increased proportion of seam welding robots in West Germany and probably elsewhere as well.

Impact of Robotization

It is clear to me that robotization of industry will create some sociological problems because the size of the work force needed for production will gradually decrease. How will these problems be dealt with? I believe that the IIW should address such questions. A new commission should be formed in the IIW for this purpose; in fact, I believe that this will be discussed at the next executive committee meeting in Tokyo in July 1986.

It is my opinion that some information germane to these questions could be obtained by an analysis of the situation in Sweden. Sweden uses more robots per employee today than the US will for many years to come. Has this caused any problems in Sweden? If so, has anything been done about these problems?

As concerns over these issues are expressed more frequently (Eichhorn's comments are very timely), perhaps the fundamental sociological question will be more carefully addressed.

Reference

Eichhorn, F., "Aspects of the Mechanisation, Automation, and Utilisation of Robots in Welding," *Soudage et Techniques Connexes*, Vol 39, No.7/8 (July/August 1985).

10/10/85

Material Sciences

THE 3RD INTERNATIONAL CONFERENCE ON COMPOSITE STRUCTURES: PAISLEY COLLEGE OF TECHNOLOGY

by Kenneth D. Challenger. Dr. Challenger is the Liaison Scientist for Materials Science in Europe and the Middle East for the Office of Naval Research's Lon-

don Branch Office. He is on leave until May 1986 from the Naval Postgraduate School, where he is Associate Professor of Materials Science.

The Third International Conference on Composite Structures was held at Paisley College of Technology, Scotland, last September. Organized by Dr. I.H. Marshall of Paisley College of Technology, this series of conferences brings together users, designers, researchers and manufacturers of structures made from composite materials, and thereby promotes the dissemination of knowledge among all sectors of this expanding technology. The participants represented are the major UK institutions involved in composite materials research (Imperial College, Royal Aircraft Establishment, National Engineering Laboratory, Paisley College of Technology, Rolls-Royce, University of Strathclyde, and University of Surrey) as well as people from many other European countries. The proceedings of the conference can be obtained from Elsevier Applied Science Publishers, New York.

General Impressions

Most of the papers were concerned with the technology of these materials rather than with research. Various applications were discussed, ranging from the use of carbon fiber-reinforced plastics (CFRP) with aerospace applications to sisal-reinforced concrete for building construction. In most applications, a component made from composite materials can be cost-competitive with a conventional (metal) component only if new design concepts are used that take full advantage of the composite material. (This usually means integrating several parts into one, thus eliminating joints.) One-to-one replacement of components made from conventional materials with those of composite materials has not generally been economical.

The structural analysts and the designers in all of the industries represented at the conference agreed that they need much more information on the mechanisms of in-service damage and damage accumulation. This is a major problem area for aerospace applications using laminated CFRP. The use of composites in aerospace applications is, however, bringing considerable attention to the problem of the damage tolerance of composites. There is much confusion about how to measure the strength and fracture resistance of these materials. In contrast to metals, fiber-reinforced laminated composites are often weaker in compression than in tension.

Any in-service damage that increases the ease with which delamination occurs (the principal failure mechanism in compression) will have a dramatic effect on the compressive strength of the component, but very little effect on the tensile strength. It was widely agreed that the worst type of in-service damage is impact damage (due to dropped tools, stones, etc.). This type of damage often causes a delamination to occur (which often is not visible from the surface that was impacted).

Fatigue fracture of CFRPs used for aerospace structures is not very likely; the static strength limits the design allowable strength for the current CFRPs. However, if improved matrix materials are developed (thermoplastics for example), fatigue failure may become more likely. With glass-fiber reinforced plastics, fatigue fracture must be considered in the design. Fatigue testing of CFRP is a controversial issue. Very little confidence exists in the laboratory test results because so many different failure mechanisms are possible. Thus, it is difficult to be sure that specimens in laboratory tests have failed by the same mechanism that will control the in-service fractures of actual components. Most designers require large-scale component testing to verify the integrity of their design.

Nondestructive examination (NDE) methods for the inspection of composites, both during manufacture and in-service, need much more development. The C-scan ultrasonic method is most widely used at present, but it is not readily applied to the in-service inspection of large components. Acoustic emission (AE) techniques and enhanced radiography were discussed, but the general opinion about their use for the NDE of composites is that they will not gain widespread use.

I have only highlighted the better papers on topics related to materials development, testing, and analysis. Many of the papers discussed specific design studies and applications using composite materials, but I have not reviewed any of these. Most of the research presented was from investigators in the UK, but there were many papers from other countries; the US was well represented.

Constitutive Equation Development

Professor H.F. Brinson (Virginia Polytechnic Institute and State University, Blacksburg, Virginia) reviewed the research at the Center for Adhesive Science at VPI on the development of analytical methodology for use in predicting the long-term durability of adhesively bonded structures. Applications for com-

posites and metallic structures were discussed. Constitutive equations, fracture models, and finite element models for the analysis of adhesively bonded joints were presented.

Even for low stress levels, the deformation of polymers is nonlinearly viscoelastic at or near, fracture. Thus, the constitutive equations for both the adhesive in a bonded joint and the matrix of a fiber-reinforced polymer should use a nonlinear representation. Brinson has modified the nonlinear viscoelastic equation developed by Schapery (1969) to make it applicable for describing the rheological behavior of fiber-reinforced plastic composites.

Dr. C. Oytana and colleagues (Laboratoire de Mécanique Appliquée Associé au CNRS, Besançon, France) have made an excellent start toward developing simple constitutive equations for glass fiber-reinforced epoxy. The model is developed from first principles, is simple, and accurately describes the creep, tensile, and stress relaxation behavior of these materials. The model only applies to uniaxial loading, but they plan to extend the model to three dimensions.

The model uses the nonlinear equation:

$$A(\sigma) \dot{\epsilon} = f(\sigma, \epsilon) + \dot{\sigma},$$

where σ is stress and ϵ is strain. The correct choice of the functions $A(\sigma)$ and $f(\sigma, \epsilon)$ can lead to relationships of the Schapery type (used by Brinson). Classical laboratory tests are used to identify the appropriate functions $A(\sigma)$ and $f(\sigma, \epsilon)$ for the chosen stress path.

Fatigue Fracture

Several papers addressed the topics of fatigue damage and prediction for fiber-reinforced composites. P.N. Barnard and R.J. Butler (Cranfield Institute of Technology, UK) and P.T. Curtis (Royal Aircraft Establishment, Farnborough, UK) explained that the very wide scatter in fatigue life for these materials can be attributed to scatter in the static properties. Static properties are logarithmically related to the fatigue properties, hence a small scatter in static strength will result in large scatter in the fatigue properties. They argued that most, if not all, of the scatter in their test data on an E-glass-epoxy, unidirectional composite could be attributed to scatter in the static strength levels of the test specimens. The corollary of this is that every test specimen has a unique fatigue life that is a function of its static strength. Hence, statistics of the scatter for fatigue test data could be predicted from static

strength tests. If this is true, drastic reductions in the amount of fatigue testing required to characterize a composite material would be possible.

S. Kellas and J. Morton (Imperial College of Science and Technology, London, UK) and S.M. Bishop (Royal Aircraft Establishment, Farnborough, UK) evaluated the notched fatigue behavior of carbon-fiber reinforced epoxy laminates where several woven plies were incorporated into the laminate. The woven fabric was located at the centerline for some of the center-notched test specimens and on the surface for others. Several different cyclic loading patterns were used, fully reversed, zero to tension and zero to compression. They find that the most damaging loading pattern is fully reversed loading. Cracking of the 0-degree fibers occurred near the notch for all tests on both lay-ups. This damage was isolated to the immediate vicinity of the notch and did not spread. Some tests were stopped after about 80 percent of the estimated fatigue life to measure the effect of the fatigue damage on the remaining static strength. For all cases, the static strength of the fatigued specimens was higher than similarly notched samples tested to failure without any prior cyclic loading. This verifies the consensus that the fatigue damage relieves the stress concentration at a notch for these materials. Although the results were not conclusive, it appears that it is more beneficial to place the woven plies on the surface rather than at the center of the laminated sheet.

Damage Tolerance

Damage tolerance is one of the hottest topics in the field of CFRP. It was the subject of an ONR, London, workshop on 12 September 1985, the day following the conference. Although not all of the following comments were expressed at the conference, they do represent the attitudes of those present at the workshop:

- The development of a damage tolerance approach to a design using composite materials is much more difficult than for metals due to the multiplicity of possible failure mechanisms and due to the high sensitivity of composites to out-of-plane stresses (causing delamination).
- Delamination types of defects have the most deleterious effect on strength, laminar composites are usually weaker in compression than in tension, and, when loaded in axial compression, the presence of the delamination causes local buckling to occur more readily.
- The worst type of damage for CFRP is that due to impact. Impact causes several forms of damage, including fiber breakage, matrix cracking, and delamination.
- A relationship between the bulk properties (individual properties) of the matrix and fibers and those of the composite is needed desperately.
- Failure criteria depend on the application. It is not as simple as for a metal; for example, delamination will drastically reduce the compressive strength but may (depending on lay-up) have no effect on the tensile strength.
- Impact damage may grow during cyclic loading.
- The characterization of damage tolerance is very difficult; it depends on the specific application (lay-up, geometry, state of stress, etc.), and thus can only be assessed with some certainty by expensive full-scale tests.
- Test methods are not standardized, and thus it is difficult for one laboratory to use another's test data.

The papers presented at the conference underlined the need for more research on the damage tolerance of CFRP.

R. Jones and A. Baker (Australian Aeronautical Research Laboratories [ARL], Melbourne, Australia) presented a paper that summarized their research on damage tolerance under compressive loading. Based upon a review of the various theoretical approaches for the analysis of delamination and impact damage, they concluded that the failure criteria (the condition for catastrophic growth of a delamination under compressive loading) should use a strain energy density approach rather than an energy release rate approach because it can predict the way (shape change) in which the delamination grows. The strain energy density method was originally proposed by Sih and Chen (1981).

The results of several experiments appear to validate their approach; the predicted point of failure matched the measured point. They have further shown that as the size of a delamination increases, a stage is reached after which any further significant increase in size only slightly increases the strain energy density. Hence there is only a small decrease in the residual compressive strength.

Jones and Baker also reported the effect of delaminations at a metal/composite step lap joint and at fastener holes. All of this work is very relevant to understanding the damage tolerance in these materials. ARL researchers

appear to be focusing more on damage tolerance than are other investigators (based on the workshop discussions, private discussions and papers presented at the conference).

Analytical Modeling

I. H. Marshall of Paisley College of Technology is making an important contribution to the methodology used to analyze the growth of delamination damage. One of the main difficulties in the analysis is that, in general, when a single delamination is formed by impact damage, the delamination is asymmetrically located through the thickness of the laminate. Thus, in-plane loads result in out-of-plane deformations. This causes interlaminar shear stresses along the front of the delamination, encouraging it to propagate. The stress field at the front of the delamination is very complex and difficult to model.

To develop an analytical model to describe these conditions, Marshall has analyzed the more simple case of a symmetrically located delamination, but he found some difficulty in experimentally verifying his model. The introduction of the delamination during the lay-up of the lamination does not simulate a delamination created by impact. Impact damage not only causes delamination, but also produces other types of damage such as fiber breakage and matrix cracking. Thus, he was faced with the dilemma of having to experimentally create a symmetric delamination by impact. He has done this by what he calls "double wall" test--i.e., he impacts the laminate from both sides simultaneously. Although this does not represent realistic damage, the test provides specimens with symmetrically located damage. He has used three specimens to test his analytical model and assess the critical parameters which cause impact damage. This work is only just beginning, but it will be very interesting to follow the progress of their research on this topic.

A. de Rouvray and colleagues (Engineering Systems International, S.A., Rugis, France) have used two- and three-dimensional finite element models (PAN-FISS/Bi-Phase Code) to predict interlaminar macro crack advance (delamination) by computer simulation. The model uses the fracture mechanics concepts of a stress intensity factor and a strain energy release rate G as the driving force for crack advance. Only tensile loading has been modeled at present, but more complex loading will be studied in the future.

The PAM-FISS/Bi-Phase fracture model separates the fiber and matrix phases

(i.e., no interactions are considered) for both stiffness and rheological computations. During each load-displacement increment, the finite elements in the process zone are scanned to select the most critical element according to a prescribed condition (which in de Rouvray's case is the maximum principal stress). The strain energy release rate is then computed for this location and compared to a prescribed critical rate (experimentally determined). When this rate exceeds the critical rate, the crack advances. The critical strain energy release rate for the T300 epoxy matrix used in de Rouvray's simulations was determined from matrix splitting and delamination experiments. This was found to be in the range of 0.12 to 0.61 N/mm; a value of 0.15 N/mm for G_c was used in their simulation studies.

The simulated cracking behavior was compared to experiments performed by the German Aerospace Research Establishment's Institute for Structural Mechanics, Braunschweig, West Germany, and good agreement existed--at least for these simple tests.

Concluding Remarks

This conference series is very useful to researchers in the field because it is comparatively small (100 to 200 participants) and attracts people from all branches of the field of composites. Thus, it is a rather unique opportunity for individuals involved in one phase of the development of these materials (for example, design) to talk to those involved in a completely separate aspect (for example, materials science). This will help the people developing the materials focus on the real problems facing the users.

References

- Schapery, R.A., *Polymer Engineering Science*, Vol 9 (1969).
Sih, G.C., and E.P. Chen, *Mechanics of Fracture 6: Cracks in Composite Material* (The Netherlands: Martinus Nijhoff Publishers, 1981).

10/15/85

Physics

SMALL CONFERENCE ON QUANTUM ELECTRONICS HAS BROAD SCOPE

by Paul Roman. Dr. Roman is the Liaison Scientist for Physics in Europe and the

Middle East for the Office of Naval Research's London Branch Office. He is on assignment until September 1987.

The Seventh National Quantum Electronics Conference of the United Kingdom was held in Great Malvern, England, from 16 through 20 September 1985. The purpose of this article is to give a general characterization of a national meeting which conveyed well, I believe, trends in the UK. For more detailed information about the conference, see ONR, London, conference report C-11-85, which you can order by filling out the return mailer inside the back cover of this issue. In addition, I will be glad to supply on request a list of all talks or substantial abstracts of the addresses given.

The meeting was organized by the Quantum Electronics Group of the Institute of Physics (UK) and cosponsored by the Royal Society of Chemistry and the Institution of Electrical Engineers (UK). The meetings were hosted by the Royal Signals and Radar Establishment (RSRE), which has its two labs in the historic Malvern area. The aim of this biennial event is to provide a national forum for the interchange of new results and information in all rapidly developing areas of quantum electronics. Despite the conference's national character, several speakers and participants came from abroad, even from as far away as the US and Australia. No Warsaw Pact countries were represented. Most speakers had university affiliations, but the proportion of government laboratory and industry researchers increased relative to previous conferences. Consequently, the proportion of papers that had a stronger technological than basic-science aspect was larger too; some of the original initiators of the conference series privately expressed their concern about this.

There were 11 invited talks, 50 contributed papers, and about 28 poster presentations. The relatively small number of participants (about 200 people, including a gratifyingly high proportion of graduate students) permitted a relaxed, close, friendly, and fruitful interaction. The program was heavy but not crowded--there was ample time for formal and informal discussions. Most participants also had the privilege of attending a special exhibit depicting the work of the RSRE. The meeting was accompanied by a minor but well-organized equipment exhibition with over 30 stands. As an extracurricular activity, participants had the opportunity one evening to attend the now cus-

tomary, ritual "Open Forum on SDI-Starwars-Space Weapons-UK/European Response."

The conference talks (15 to 30 minutes long) were given in the following groups of presentations:

- Lasers (four sessions)
- Nonlinear Optics (two sessions)
- Quantum Optics (two sessions)
- Electro-optics Devices
- Spectroscopy
- Miscellaneous Applications (two sessions)

In my opinion, the presentations on lasers and laser systems dominated not only in number but also in quality. Highlights included new results on subpicosecond and femtosecond research, multi-wavelength lasers, tunable novel solid-state lasers, and progress in dye laser techniques.

The second leading group of papers, in the general area of nonlinear optics, began with a sequence of presentations related to optical bistability. Phase conjugation, four-wave mixing, and liquid crystal systems were also well-discussed topics. I think that these are now favored British research areas.

In the field of quantum optics, great emphasis was given to the popular topics of squeezed states and other phenomena related to nonclassical photon statistics. There were also theoretical talks on subtle questions of atomic physics.

Electro-optics devices and miscellaneous applications of quantum electronics were given a poor treatment, except for an interesting tutorial on molecular electronics and an unusual presentation of work on degenerate four-wave mixing in flames.

In the short session on spectroscopy I found a talk on stimulated Raman scattering in gases and liquids the most imaginative presentation.

In summary, this meeting was relaxed and fruitful, and despite the fact that no major breakthroughs were reported, it served its avowed purpose of periodically getting together a dedicated community of older and youngish researchers in a country that has a good tradition in quantum electronics.

10/11/85

VERY SHORT LASER PULSE RESEARCH AT TUM

by Paul Roman.

Munich, West Germany, is a center of laser research. In previous *ESN*

issues I have surveyed some of the activities at several large research institutes and industrial research laboratories; in this article I shall report on my visit, in July 1985, to a quieter, smaller, yet very remarkable activity: the Physics Department E11 of the Technische Universität München (TUM, Technical University of Munich).

The relatively small institute (about four permanent postdoctoral research staff and nearly a dozen research students) is headed by Professor Dr. W. Kaiser. After a long early career in solid state physics, lasers, and nonlinear optics (including a long stint with the US Army Signal Corps), he founded the institute in 1964. The specialty of this research center is the generation of very short (picosecond and femtosecond long) laser pulses by various techniques and the application of these pulses for studies in molecular physics (transient phenomena, short relaxation time processes, molecular dynamics), in semiconductor physics, and in biophysics (bacterial photosynthesis). I describe in some detail three particular research projects that I believe will be of considerable interest to *ESN* readers.

Colliding-pulse Mode-locked Ring Dye Laser

It is quite well known that passive mode locking of a ring dye laser by the interaction of two counterpropagating pulses in a thin saturable absorber (for short: colliding-pulse mode locking, CPM) yields femtosecond pulses. In these lasers, the gain medium (Rhodamine 6G) is pumped by a cw-operated Ar^+ ion laser, and the saturable absorber (usually diethyloxadicarbocyanine iodide [DODCI]) synchronizes the two counter-

propagating pulses that meet in the jet stream. Here the colliding pulses form a transient grating which not only synchronizes but also stabilizes the pulses. But this laser system has several shortcomings. The most important of these is that one cannot easily obtain a second ultrashort light source at some other frequency which would be synchronized with the CPM laser pulse, whereas most excite-and-probe experiments would need such an additional pulse. Drs. M.C. Nuss, R. Leonhardt, and W. Zinth overcame the difficulties by constructing a CPM laser which was synchronously pumped by a suitably arranged sequence of pump pulses. They set the distance between the absorber and the amplifier of the CPM laser to be the fifth of the cavity perimeter's length. Since the dye laser pulses generated by two subsequent pump pulses should collide in the absorber jet, the gain medium must be pumped at times $t=0, 3/5 T, T, 8/5 T, 2 T, \dots$, where T is the cavity round-trip time.

The schematic diagram of the arrangement is shown in Figure 1. The ring laser itself is represented by the hatched mirrors. M1 through M4 are focusing mirrors, M5 and M6 are flat mirrors; G is the gain jet; A the absorber dye jet; and OC a 2.5-percent transmission output coupler (mounted on a precision translation stage). The pump geometry is symbolized by the filled mirrors. The pump beam is divided into two parts of equal power by the beam splitter BS. The reflected beam is focused by the mirror MP directly into the gain jet, whereas the transmitted beam first passes an optical delay line and is then focused into the gain dye jet. The mode-locked pumping Ar^+ ion laser beam has

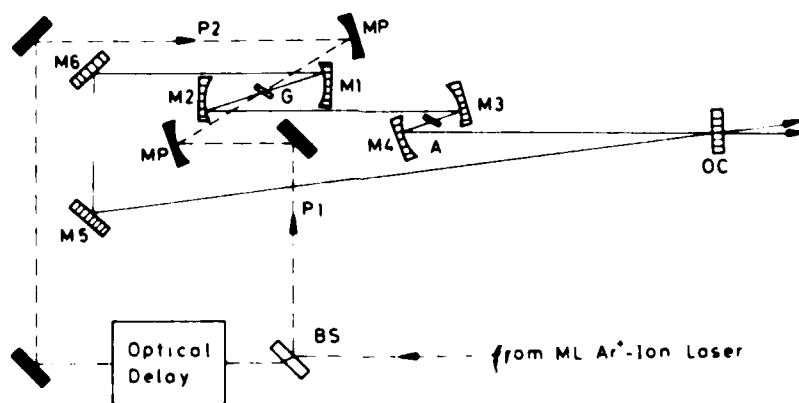

Figure 1. Schematic diagram of the synchronously pumped CPM ring dye laser.

the same cavity round-trip time T as the ring laser, and supplies pulses P_1 that enter the gain jet at $t=0, T, 2T, \dots$. The second train of pump pulses, P_2 (transmitted through BS and then delayed), are made to arrive at the gain medium at $t = 3/5 T, 8/5 T, \dots$. All pulses are focused into the gain jet by mirrors which have a 150-mm focal length. The delay of $3/5$ round-trip time in the gain medium between the two pump pulses guarantees that only the dye laser pulses resulting from pump pulses with $3/5-T$ delay with respect to one another collide in the absorber jet stream and form a transient grating. The 1.1-ns absorption recovery time of DODCI ensures that the other two pulses, which may also be generated in the gain medium, do not meet in the absorber and thus experience a higher loss, so that they are suppressed.

The pulses of this CPM laser were carefully analyzed by four different techniques. It was found that (with precise alignment) 620-nm pulses, as short as 100 fs, could be obtained. Provided the optimum cavity length was maintained within better than $0.2 \mu\text{m}$, the pulse trains were stable over several hours. They carried 28-mW power, and had a ripple less than 5-percent root mean square. The clean spectral shape (4.6-nm width) is shown in Figure 2. It should be noted that the superior performance of the CPM laser required, apart from the perfect match of the lengths of the Ar^+ and CPM laser cavities, a good mode-locking and stable operation of the

pumping laser. The latter was operated at the 500-mW power level.

Tunable Picosecond Pulses in the Medium Infrared

I understand that a unique achievement of the TUM institute is the generation of few-picosecond-long pulses in the mid-infrared (MIR) with a substantial tuning range and a small, constant bandwidth.

Using the now well-established method of parametric three-photon interaction in nonlinear crystals (such as LiNbO_3 or LiIO_3 for near-IR, Ag_3AsS_3 or CdSe for MIR), various authors reported successful operation with one or another specific feature. In 1984, Kaiser and coworkers built a single-path parametric system for MIR, consisting of two AgGaS_2 crystals. It was pumped by picosecond pulses from a Nd:Yag laser and was tunable between $1.2 \mu\text{m}$ and $10 \mu\text{m}$. However, the scientists were not satisfied, because when a single-path arrangement is used, the spectral bandwidth changes appreciably with the wavelength, within a factor of 10. A broad bandwidth limits the value for spectroscopic studies. T. Elsaesser, H. Lobentanzer, and A. Seilmeier realized that substantial improvement should be possible by mixing two picosecond pulses of small bandwidth in the nonlinear medium to generate pulses at the difference frequency (down-conversion).

In a very recent experiment, 21-ps-long, 10-mJ pulses (spectral width less than 2cm^{-1}) were generated in a Nd:Yag

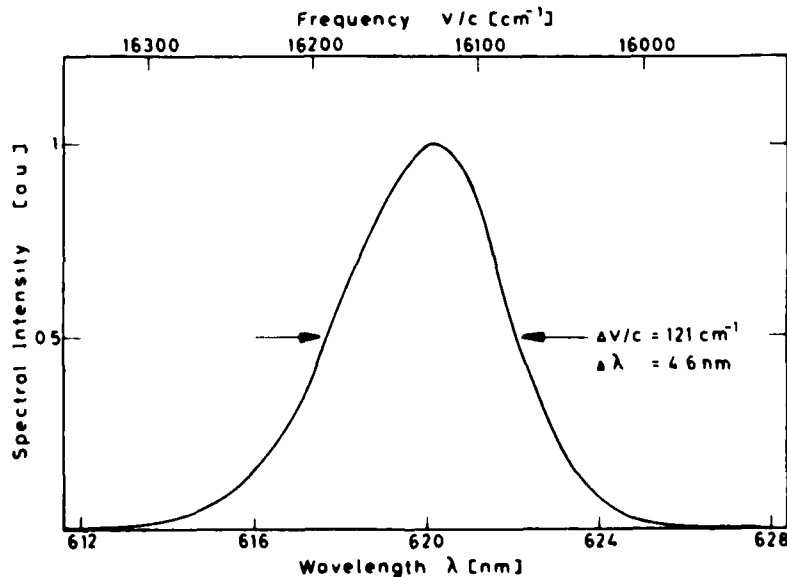

Figure 2. Spectrum of the CPM laser.

laser system consisting of a passively mode-locked oscillator, a single-pulse selector, and two amplifiers. The pulse passed a beam splitter with 30-percent transmission. The pulse reflected from the beam splitter served as an intense pump for the nonlinear process. The transmitted pulse pumped a traveling wave infrared dye laser. (The dye laser will be described below.) This novel arrangement is probably the most fascinating feature of the system. A reflection grating was used as the tuning element. The dye laser gave out single-picosecond pulses, tunable over several hundred nanometers in the near IR. The fixed pump beam (peak intensity 2 GW/cm^2) and the tunable dye laser beam then entered the 1.5-cm-long AgGaS_2 crystal collinearly, after the intensity of both pulses has been increased by a telescope in front of the crystal. By parametric amplification in the crystal, an intense, highly collimated idler pulse at the difference frequency is generated, and this pulse travels collinearly with the two incident pulses. The two pump frequencies are then blocked by a germanium flat.

A variety of analyzing components were used to determine the properties of the radiation generated. The main results are as follows. The down-conversion gave parametric pulses from $3.9 \mu\text{m}$ to $9.4 \mu\text{m}$. Figure 3 shows the calculated (solid curve) and observed (circles) tuning curve. (Note that the tuning of the dye laser and the rotating of the crystal must be done simultaneously.) The spectral bandwidth of the pulses was only 6.5 cm^{-1} , and it was constant over the entire tuning range. The duration of the pulses was less than 8 ps; in certain cases even as short as 3 to 5 ps. Several percent of the Yag photons were converted to MIR photons. Actually, the photon conversion efficiency of the parametric generation process peaks at about $5\text{-}\mu\text{m}$ wavelength, where it reaches a value of about 4 percent. At $4 \mu\text{m}$ it is just under 1 percent, and at $9 \mu\text{m}$ somewhat less than 0.1 percent.

Traveling-wave Dye Laser. The tunable dye laser used in the down-converting process deserves some comments, the more so since in itself it can be used for fast excite-and-probe experiments and since further development of this system is in progress.

An earlier version of the dye laser was described by Kaiser, Elsaesser and associates in the *IEEE Journal of Quantum Electronics*, QE-20 (1984), 281. The present system uses longer pump pulses and has a tuning element of higher spectral selectivity. The active medium is a 1,2-dichloroethane solution of dye No. 5,

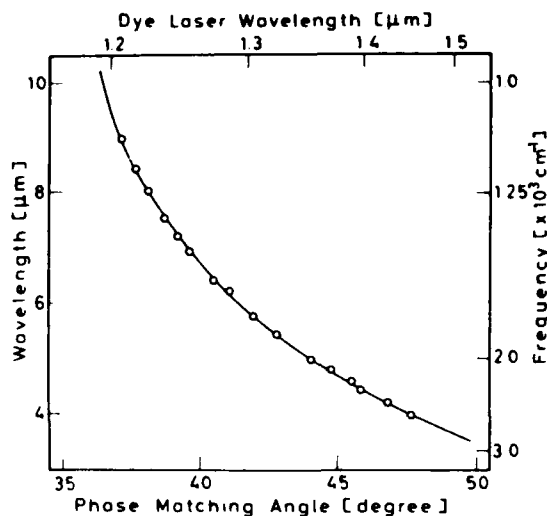

Figure 3. Tuning curve of the AgGaS_2 down-converter.

which usually is employed as a switching (not lasing) dye. This is pumped by the 21-ps pulses (at $1.064 \mu\text{m}$) of the Nd:Yag laser. Tuning is achieved by a 600 grooves/mm reflection grating. The tuning extends from $1.200 \mu\text{m}$ to $1.460 \mu\text{m}$, and the output energy peaks at $1.330 \mu\text{m}$. At the upper end of the tuning range, the power is down by a factor of 10 of the peak output, and at the lower end by a factor of four. At the peaking frequency, 3 percent of the pumping energy is converted to the tunable dye laser pulse. The spectral bandwidth of the pulses is determined by the selectivity of the tuning element and, in agreement with calculations, it was found to be $7 \pm 2 \text{ cm}^{-1}$. It was remarkably constant over the entire tuning range.

The temporal properties of the pulses were investigated in much detail by a sophisticated cross-correlation technique. The pulse duration of the dye laser was $20 \pm 2 \text{ ps}$, provided the pumping Nd:Yag laser pulses lasted 21 ps. The correlation traces also indicated that a time resolution of 6 ps can be expected if the dye laser system is used in excite-and-probe experiments. Finally, it was confirmed that the temporal characteristics of the dye laser are very strongly influenced by the pump pulse duration. This is so because the dye laser is operated in a strong gain saturation condition, and the pump pulse duration exceeds the S_1 state lifetime of the dye by a factor of six, so that the temporal development of the population inversion in the dye follows the envelope of the pump pulse.

Molecular Dynamics Research With Short Pulses

The major applications of the various short-pulse lasers developed in the institute have been, so far, in the area of studies concerned with the flow of energy within large- and medium-sized molecules and with the energy dissipation to the surrounding solvent. In these processes the appropriate time constants range from tens of femtoseconds to approximately 10 ps.

In particular, special attention was given to the following phenomena:

1. The intramolecular redistribution of vibrational energy.
2. The transfer of energy from the heated molecules to the solvent.
3. The reverse process, where the vibrationally excited solvent molecules give their energy very rapidly to probe molecules which serve as "molecular detectors."

Three different experimental techniques have been developed:

1. The molecules were excited by ultrashort (about 5 ps) IR pulses, and the instantaneous degree of excitation is determined by the anti-Stokes Raman signal which is obtained from a properly delayed visible probe pulse.
2. Transient changes in the population of a vibrational manifold were determined by studying a variation of the edge absorption. (The basis of this approach is that the long wavelength edge of the absorption of most molecules represents optical transitions from the thermally populated vibrational manifold of the ground state to the first excited electronic S_1 state.)
3. For high-lying (hence very weakly populated) vibrational modes, the enhanced fluorescence was studied to give a good measure of the redistribution of vibrational energy. This method is justified because in these cases the transition to S_1 is too small to be observed.)

Experiments were conducted in the past 2 years with naphthalene, anthracene, and various large dye molecules. In contrast to earlier experiments with small molecules with a few normal modes (where the possible decay routes are quite limited and may be followed experimentally), it was found that in large molecules (perhaps not unexpectedly) a statistical relaxation mechanism has to be considered, on account of the large density of the vibrational states. Consistent results showed that the energy supplied to the molecule via vibrational absorption bands is rapidly (in less than 1-ps time) redistributed over the

vibrational manifold of the electronic ground state. The observed vibrational states are temporarily populated as if the molecules have acquired a higher temperature. The energy transfer to the surrounding solvent molecules proceeds considerably slower (the time constant is of the order of 10 ps). Preliminary data suggest that the observed intermolecular processes occur via translational and rotational motion of the molecules.

Two-beam Visible and Ultraviolet Parametric Generation in Crystals.

I describe now the experimental setup that was used in the molecular dynamics studies, because this parametric system with up-conversion is interesting per se (even though perhaps it is not unique) and may have a variety of other applications as well.

The block scheme of the experimental system is shown in Figure 4. A mode-locked Nd:glass (or Nd:Yag) laser pumps two optical parametric systems. The lower part of the scheme indicates that two LiNbO_3 crystals produce tunable IR pulses (with frequency ν_1 .) (These are used in the experiments to excite the sample.) The other beam (reflected from the beam splitter) is first up-converted to the second or third harmonic frequency with two potassium dihydrogen phosphate (KDP) crystals. Following a filter, two pumped ammonium dihydrogen phosphate (ADP) crystals allow the generation of tunable visible or ultraviolet pulses (with frequency ν_2 .) The method of parametric generation has the advantage of very convenient tunability over a wide frequency range, which the authors found to cover many thousand wavenumbers. They also ascertained that--provided the input pulses have good reproducibility--the time jitter between the ν_1 and ν_2 pulses is less than 0.5 ps. (This assures a favorable time resolution of the entire apparatus.)

After their generation, the two pulses are properly delayed against each other (variable time delay can be arranged) and combined to enter the sample collinearly. The resulting Raman signals (or the fluorescence, or the absorption changes, as the case may be) are measured with suitable monochromators and photomultiplier detectors.

The researchers found it necessary to measure, simultaneously with the observation of the sample radiation, the cross-correlation curve between the two pulses ν_1 and ν_2 . This was accomplished by observing the sum-frequency $\nu_1 + \nu_2$ behind the nonlinear LiIO_3 crystal (see lower right of Figure 4). The cross-correlation curve provides the zero-point

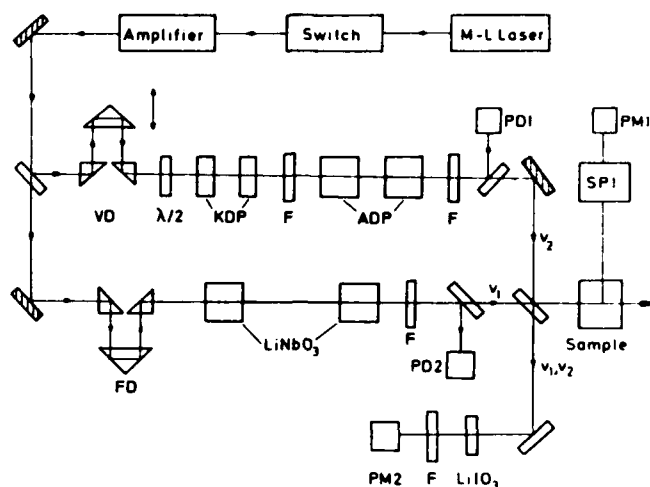

Figure 4. Block scheme of the tunable two-beam IR-UV experimental setup.

of the picosecond time scale and also gives a good indication of the pulse duration involved, as well as of the current time resolution of the system.

Additional technical details (of the earlier versions of the system) can be found in a paper published by the Kaiser group in *Chemical Physics Letters*, 105 (1984), 140.

Outlook

The researchers in the TUM Physics Department plan not only further molecular dynamics experiments but also have started interesting new studies in semiconductor physics. For example, they investigated with their very short pulse techniques the degree of nonlinearity and the time scale of optical processes in InBiO_3 . This substance exhibits an unusually high nonlinearity in the neighborhood of the band edge and is a promising material for optical bistability devices, especially since the Kaiser group found that the time scale associated with the nonlinear behavior is less than 2 ps. (This value is the current resolution of the system they used.) Other plans involve short-timeframe investigations of a variety of semiconductor effects, and the study of self-phase modulation.

This is a small but vigorous group and one which (despite a certain single-perspective aspect of development) is not likely to become stagnant.

News and Notes

CONFERENCE ON FORMATION OF SEMICONDUCTOR INTERFACES

The International Conference on the Formation of Semiconductor Interfaces was held in Marseilles, France, from 10 through 14 June 1985.

Many aspects of interface physics were covered at the conference. The main theme was understanding the microscopic structure and chemistry of the interface and their influence on macroscopic properties such as Schottky barrier height. Considerable controversy still exists as to the extrinsic (impurity) versus intrinsic (surface state) origin of Fermi level pinning in determining the Schottky barrier.

The new technique, scanning tunneling microscopy, and the more recent scanning tunneling microscope spectroscopy received considerable coverage. At the present, the main impact of these new technologies is to rule out some of the theoretical models. However, resolution of the image and lack of detailed theoretical understanding prevent a unique determination of the structural model. The classic case of (2×2) Si(111) is still not resolved. In fact, D.J. Chadi discussed two new models that are still in contention and are compatible with the scanning electron microscope image.

10/11/85

In the session on fine-scale characterization, Dr. Van der Veen from Amsterdam gave a plenary lecture on using the ion beam scattering technique to determine the interface structure. The technique is sensitive enough to identify the microscopic strain structure of the surface. The one uncertainty remaining in the interpretation of the data is the lack of precise information on the vibrational amplitude and correlations of surface atoms. Van der Veen also had done ion scattering experiments on Si(100) and Si(111) faces, and he is extremely interested in the results on the vibrational properties of Si(100) that I presented at the conference.

Dr. Venables (Sussex, UK) gave a very interesting talk on diffusion and nucleation of metal adatoms on Si(100) and Si(111) faces. By cleverly masking most of the surface, except for a small hole area, he is able to follow the motion of adatoms with an electron microscope beam. In the dilute limit, this would give information on single-adatom diffusion rate. For higher coverage, the size and shape of the island growth can be fitted qualitatively by a simple nucleation theory. One of the main parameters in the nucleation theory is the diffusion constant of the adatom.

See-Chen Ying
10/29/85

COLLOQUIUM SPECTROSCOPICUM INTERNATIONALE XXIV

Colloquium Spectroscopicum Internationale (CSI) is the premier international conference devoted primarily to the analytical chemistry applications of spectroscopy. The 24th CSI was held last September in the Kongresshaus at Garmisch-Partenkirchen, West Germany, under the auspices of Gesellschaft Deutscher Chemiker and the Deutsche Bunsen-Gesellschaft für Physikalische Chemie. It was sponsored by the International Union of Pure and Applied Chemistry. There were 891 registered active participants from 42 countries (about 10 percent from Eastern Europe). The seven invited lectures on x-rays are covered here. The lectures will be published as a special edition of *Fresenius' Zeitschrift für Analytische Chemie* (Springer-Verlag, 175 Fifth Ave., New York, New York 10010).

Two of the lectures were surveys dealing with the two branches of x-ray instrumentation: wavelength dispersion and energy dispersion. J.L. deVries--

still associated with Philips, although formally retired for about 5 years--reviewed wavelength dispersive x-ray spectrometry, concentrating on a comparison with a similar paper he presented in 1965 at CSI XII. He concluded that the field has not changed much during that period, and that further development will come slowly rather than by large jumps forward. R. Van Grieken (University of Antwerp, Belgium) discussed the present state of energy dispersion, noting that secondary target excitation is being used less often compared to direct tube excitation and that much attention is being focused on polarized beams and total reflection.

P. Wobrauschek and H. Aiginger (Atominstitut, Vienna) discussed the details of the analytical application of total reflection and polarized x-rays, an area in which they have been working for many years. W. Michaelis (GKSS-Research Center Geesthacht, West Germany) compared total reflection and polarized x-ray fluorescence spectrometry, neutron activation analysis, and inductively coupled plasma optical emission spectroscopy for multielement analysis of environmental samples. Michaelis concluded that each method has its own particular domain. H. Rethfeld and G. Crossmann (Agricultural Research Institute, Munich) described the extension of x-ray fluorescence analysis to agricultural problems.

S.A.E. Johansson, one of the foremost researchers in proton-induced x-ray emission, characterized the state of the art of that technique and illustrated its applications in a number of different fields. B. Sonntag (University of Hamburg) depicted some chemical applications of synchrotron radiation, concentrating on the analytical impact, such as a source for x-ray fluorescence analysis.

CSI XXV will be held in Toronto, Canada, from 21 through 26 June 1987; it will be sponsored by the Spectroscopy Society of Canada, the National Research Council Canada, and the Society for Applied Spectroscopy (US).

John V. Gilfrich
Naval Research Laboratory
10/30/85

ESPRIT PROGRESS ASSESSED BY EEC

The European Economic Community held a technical review of its ESPRIT program of research in information technology last September. The following is

a summary of remarks made by J.M. Cadiou, Director, Information Technologies--ESPRIT, Task Force Information Technology and Communications, Commission of the European Communities.

* * *

The ESPRIT program has now been in operation 1½ years, and we have issued calls for proposals in 1984 and 1985. In 1984 more than 100 projects were selected for funding, and in 1985 nearly 100 further ESPRIT projects were chosen for funding. Response to the requests for proposals was so great that we were able to select one out of five for funding. If all the selected projects run to completion, then all of the funds for the first 5-year program will have been exhausted--except about 5 percent held back for administration. Any new project funding will have to come out of attrition of the existing projects, and this is likely to happen.

The total number of projects now chosen for ESPRIT is 175. About 448 different organizations are represented, and by the end of 1985 about 1300 people will be at work on the various projects. The peak of 2000 in number of people is expected to be reached by mid-1986.

The program is backed by 750 million European Currency Units (ECU; 1 ECU = \$0.85), and the participating companies are expected to put up an equal amount of funds. There are a number of projects financed at more than 15 million ECU and a few at more than 25 million ECU. There are a large number at funding levels below 5 million ECU.

The ESPRIT program is already beginning to produce some early results. Some examples are briefly described below.

1. Project 97 (advanced algorithms, architectures, and layout techniques for very large scale integration signal processing) has produced a solution for a particular type of architecture, among several being investigated, which is one order of magnitude more efficient than the present state of the art. The same project has developed a computer-aided-design tool which, together with other existing tools, allows the completely automated design of complex integrated-circuit (IC) digital filters in less than a week.

2. Project 440 (advanced message passing architectures and description systems) has provided the basis for the development of a product (OMEGA, a programming environment to develop knowledge base systems) which is marketed by

Delphi, a small company that is the main contractor in the project.

3. Project 623 (operational control for robot systems integration), after completion of a first work phase, has produced a report on "Design Rules for Robot Integration into CIM." The project is investigating the problem of the integration of various technologies in computer-integrated-manufacturing (CIM) systems and will provide results applicable not only to industrial robots but also to material handling equipment, computer numerical control machines, etc.

4. Project 232 (compound semiconductor materials and ICs) has already met some of its technology objectives. The success of the project, together with results achieved in other complementary programs by the same consortium (LEP, Plessey, Siemens, Thomson), has led to the realization of GaAs metalized semiconductor field effect transistor, 256-bit, static random access memory (SRAM) circuits with an access time of 1.5 ns. LEP has also announced the successful operation of 1K SRAM with a longer access time (3.4 ns) but very low power dissipation.

5. Project 107 (LOKI, a logic-oriented approach to knowledge and databases supporting natural user interaction) has developed tools to optimize access to databases, thereby winning the "supreme prize" at the 1984 European Conference on Artificial Intelligence.

6. Project 121 (handling of mixed text/image/voice/documents based on a standard office documents architecture) has defined an office document architecture (ODA), resulting in recommendations to the European Computer Manufacturers Association (ECMA) and the International Organization for Standardization. ODA standards were accepted by ECMA in June 1985.

7. Project 32 (PCTE, portable common tool environment), aimed at providing a supporting structure for a family of portable tools, has realized the first prototype, based on the ADA language. PCTE will provide software developers with a homogeneous software development environment onto which many existing tools can be ported, which will also make it possible to use new tools produced by other ESPRIT projects or outside ESPRIT.

The ESPRIT program has been assessed by an independent board, and a report is due at the beginning of November 1985. The assessment was based on interviews and questionnaires. Some early findings are that cooperation is working well, mutual trust has developed, and

ESPRIT is considered a good thing at all levels. On technology, the view is positive, and the feeling is that ESPRIT is speeding up research work. The opinion is that Europe is in a stronger position on standards as a result of ESPRIT.

Among the criticisms of the program are the need for more and better communication among participants and a more strategic focus.

For the future, the following are important tasks:

1. Manage what we have and improve cohesive communication.
2. Prepare for Phase II, which may mean to bring forward the start up of the second 5-year phase. Continue the upstream (precompetitive) character, but also do some large demonstrators.

J.F. Blackburn
10/23/85

NATO ASI ON KINDLING TO BE HELD IN ITALY

A North Atlantic Treaty Organization (NATO) Advanced Study Institute on "Kindling: A Model for Behavioral Neuroscience" will be held from 18 through 29 May 1986 in Maratea, Italy. For information, please write to the director of the course: Dr. David I. Mostofsky, Boston University, Psychology Department, 64 Cummington Street, Boston, MA 02215.

The purpose of this institute is to bring together current knowledge of theory and research in the area of neurophysiology and behavior as they relate to kindling. Kindling is a lasting change in brain function that results from repeatable focal stimulation and leads to the development of a predisposition to epileptiform convulsions. The neural basis is known to be very long lasting, transynaptic, pathway specific, and widespread. A satisfactory explanation of its mechanisms has not yet been provided. Because kindling represents an instance of neural plasticity, knowledge about it has become important for better understanding of learning, memory, and higher cognitive processes.

The intended audience will be largely postdoctoral, with a few predoctoral participants. The opportunity for short communications and ample discussion will be provided. Registration is limited to applicants from NATO countries.

David Mostofsky
Boston University
10/29/85

SIGNIFICANT PROGRESS IN MULTIMODE FIBERS

Most breakthroughs in fiber optics occur in the area of ever-better single-mode fiber production, because high-speed transmission over long distances requires, preferably, single-mode transmission. But narrow-band, long-distance messages (using the 850-nm wavelength) in local telephone-type networks may be transmitted more easily and at a lower cost with very high quality, multimode, graded-index fibers. In this respect the recent announcement of the Philips Communication Industrie A.G. deserves special attention.

Philips researchers at the F&G telecommunication lab (Köln) and at the TE-YA-DE lab (Nürnberg) succeeded in showing that 565 Mb/s transmission through 37 km, without repeaters, is possible with the graded-index multimode fiber produced experimentally at the Philips plant in Eindhoven, The Netherlands. The fiber used in these experiments has a 50- μ m core; the loss at 1.317- μ m wavelength is 0.55 dB/km. Apart from the use of such a fiber in narrow-band, long-distance transmission as noted above, Philips suggested also good applications under more stringent and more general conditions, emphasizing particularly the ease of coupling light into the fiber's large core.

Apart from the West German Post Office--which will use the new fiber in its large-scale exploratory new fiber project between Hamburg and Hannover--France is also interested in improving multimode fibers.

Paul Roman
1/14/86

ADVANCES IN OPTICAL FIBER RESEARCH IN THE UK

A symposium on advanced measurement techniques and characterization of optical fibers was held on 10 September 1985 at the Teddington center of the UK National Physical Laboratory. The reports were presented by participants in the British Joint Opto-Electronics Research Scheme (JOERS) project. JOERS is directed from the Department of Trade and Industry (DTI), and its purpose is to stimulate research in optoelectronics, including new materials, sensors, integrated optics and optoelectronics, and displays. The format of this project is collaborative research between industry and the universities. The government funds about half of the work at participating companies and supplies

scholarships as well as other expenses as needed for the universities.

Major topics discussed at the symposium were as follows:

- Characterization of single-mode fibers by measurement of equalization wavelength.
- Dispersion measurement in single-mode fibers with the phase-shift method.
- Interferometric measurement of the polarization dispersion in single-mode fibers.
- Resonant core-cladding mode coupling in single-mode fibers.
- Microbending.

For more information, contact the DTI, 1 Victoria Street, London SW1H 0ET; phone: [44-1]-215-3793.

Paul Roman
3/13/85

ADVANCED HIGH-POWER CO₂ LASER

The Stuttgart laboratory of the German Deutsche Forschungs- und Versuchsanstalt für Luft und Raumfahrt (DFVLR) has developed a very robust, turnkey-type, 1-kW power CO₂ laser which attracted large crowds when demonstrated at the "Laser 85" fair in Munich last July. The compact, easily controlled system is the result of several years' work, supported in part by the "High Energy Processes" program of the Baden-Württemberg State Government. The laser has an axial gas flow system and uses radio-frequency excitation with a very high (13.56 MHz) frequency. (This ensures long lifetime for the electrodes.) The layout consists of six folded, 40-cm-long, active sectors, each having a volume of 400 cm³. The efficiency is greater than 10 percent. Over 80 percent of the power output is in the TEM₀₀ mode. Continuous operation for over 1 hour without gas exchange is possible.

Further details may be obtained from DFVLR, Institut für Technische Physik, Pfaffenwaldring 30-40, D-7 Stuttgart 80, West Germany.

Paul Roman
3/13/85

NEW INTERNATIONAL JOURNAL TO COVER THE INTERFACE OF CHEMISTRY AND ELECTRONICS

Last February I reported on a new journal for molecular electronics. Its

"spiritual leader," Professor R.W. Munn, is in the Department of Chemistry, University of Manchester Institute of Science and Technology (see *ESN* 39-2:65 [1985]). I must assume that the venture proved to be a great success, since I have now learned about a brand new journal covering a closely related area--and its chief editor, Dr. J.O. Williams, is a member of the same department!

Chemtronics, the title of the journal, is a term used to describe phenomena at the interface of chemistry and electronics. The subjects to be covered in the journal will deal with the chemical and solid-state aspects of electronics materials, processes, and devices. The goal is to bring together very different and diverse aspects of the basic sciences as well as of the technology in chemistry and physics as applied to the study and development of processes, materials, and devices which play a role in microelectronics and optoelectronics. The journal will also provide a common forum for scientists interested in the general area of chemicals for electronic uses. Research papers, rapid communications, review articles, book reviews, patent reports, conference reports, and calendars of forthcoming events are being solicited. Further information and a sample copy may be obtained from the publishers. Write to Mrs. Sheila King, Butterworth Scientific Ltd., P.O. Box 63, Westbury House, Bury Street, Guildford, Surrey, GU2 5BH, UK.

Paul Roman
8/20/85

SERC BULLETIN REPORTS ITEMS OF INTEREST TO CHEMISTS

The UK's Science and Engineering Council (SERC) is one of five research councils funded through the Department of Education and Science. Its mission is to sustain standards of education and research in the universities and polytechnics by grants and fellowships. SERC also provides facilities for academic research. The *SERC Bulletin* summarizes SERC policies, programs, and reports. Items of interest to chemists that appear in Volume 3, Number 3, Autumn 1985, are summarized here. Further information can be obtained from the editor, Miss J. Russell, at SERC, Polaris House, North Star Avenue, Swindon SN2 1ET, England.

Biology and Chemistry Facilities at the Central Laser Facility

X-ray Microscopy. W.T. Toner from the Central Laser Facility (CLF) at the Rutherford Appleton Laboratory describes recent x-ray microscopy experiments that show features not seen before in biological specimens. CLF is exploiting the intense x-ray emission for analysis of materials rather than investigating the properties of matter under extreme conditions produced by large lasers focusing on materials (temperatures greater than 10^7K at pressures over 10^8 atmospheres).

The specimens to be x-rayed, which may be wet and up to 10- μm thick, are placed in contact with an x-ray sensitive resist behind a thin silicon nitride window in a vacuum-tight holder. The assembly is mounted in the evacuated target chamber a few centimeters from the target on which the laser will be focused. Biological samples are handled so that a natural contrast is obtained without staining to reveal the distribution of organic material in the presence of water.

A single laser shot giving a burst of x-rays lasting less than 100 ns is sufficient for the exposure. VULCAN (Nd-glass laser) and SPRITE (KrF gas laser) have been used for the flash x-ray sources. Because there is not time for any change in morphology to occur, the appearance of the living specimen can be recorded despite the lethal radiation dose that is needed for high resolution. After the shot, a relief image having a resolution better than 100 nm is obtained. This is examined with a microscope at high magnification.

Small Lasers. Smaller lasers at the CLF have tunable coherent radiation. These lasers enable users to apply the technique of resonance Raman spectroscopy by using the electronic resonances that occur in the ultraviolet to couple with specific parts of molecules. Thus, Raman scattering peaks due to transient intermediates in catalytic reactions can be observed. For example, in a reaction catalyzed by an enzyme, where normally a chromophore to monitor the reaction at long wavelength radiation is required, an intermediate has been observed in natural conditions with resonance Raman spectroscopy. The resonance Raman spectra will make it possible to monitor the behavior of bonds undergoing catalytic transformation in the active center of the enzyme. This should ultimately contribute to finding new catalysts of industrial, biotechnological, and medical importance.

A new laser support facility (LSF) will provide spectral coverage from the

vacuum ultraviolet to the near-infrared. LSF will include a picosecond laser, as well as the excimer and dye lasers presently in use. Dr. M.H. Key, Head of Laser Division, Rutherford Appleton Laboratory, Chilton, Didcot, Oxon OX11 0QX, England, can provide further details of available lasers.

The Synchrotron Radiation Source in High Pressure Research

The use of high pressure as a tool to investigate solid state phenomena has become increasingly important. Because of advances involving the diamond anvil cell, many chemists, physicists, biologists, and material scientists are beginning to include high pressure techniques in their experiments. The *SERC Bulletin* reviews work involving the Synchrotron Radiation Source (SRS) at Daresbury Laboratory, Cheshire.

Properties that make synchrotron radiation ideally suited to high pressure studies are: the radiation is a continuum extending from x-rays through ultraviolet and visible wavelengths to the far infrared region; and it is pulsed, plane-polarized, very intense, and well collimated in the plane of the accelerator. The high pressure equipment at Daresbury Laboratory, as reported by Dr. P.D. Hatton, is based on two different designs of diamond-anvil cells for single-crystal measurements up to 100 kbar (1 kbar = 0.1 GPa = 10^3atm) and energy-dispersive powder diffraction up to 500 kbar. To date, extended x-ray absorption fine structure (EXAFS), powder diffraction, and far infrared spectroscopy have been used at high pressures with the SRS.

Analysis of an x-ray absorption spectrum can yield valuable local structural information (specific interatomic distances and coordinating numbers), even in noncrystalline phases. The effect of pressure on the interatomic distances of amorphous materials and liquids can be investigated; information on new high-pressure structural phases, including valence changes, can be determined. Most high pressure EXAFS studies have used Bridgeman anvil cells, but the diamond anvil cell is preferred for pressures above 100 kbar. However, the presence of Bragg peaks from the diamond windows that overlay the EXAFS spectra is a disadvantage that can be tolerated.

The powder diffraction station at the SRS is situated on the wiggler beam line that provides hard x-rays up to about 100 keV. This smooth continuum is exploited in energy-dispersive powder diffraction, the principal method of obtaining quantitative structural information at high pressures. The sample and

the detector in this technique are fixed, and the pattern is observed as a function of energy (wavelength) by the energy-resolving detector. Extremely small samples can be studied very rapidly because of the intensity and collimation of synchrotron radiation. Useful diffraction patterns can be obtained in a few seconds. This makes it ideal for studying kinetic phenomena.

Spectroscopy in the far-infrared and submillimeter regions has always been severely hampered by the lack of bright and intense broadband sources. By the use of synchrotron radiation, improvements in spectral intensities between 5 and 25 times are realized, compared to conventional mercury arc lamps. Far-infrared spectra at high pressures can be readily obtained by use of synchrotron radiation.

Hattan reports that experiments planned include Laue diffraction using single crystals, time-resolved fluorescence spectroscopy, and high-resolution powder diffraction. Improvements in facilities are planned and include cryostats, laser heating, and position-sensitive detectors.

Major New SERC Grants Approved, April-July 1985

- Professor A. Pelter and Dr. J.A. Ballantine (University College, Swansea): £611,800 (\$890,000) over 4 years, for the establishment of a SERC Mass Spectrometry Center in Swansea.
- Dr. G.C.K. Roberts and Professor W.V. Shaw (Leicester University): £329,000 (\$480,000) over 4 years, for research on high field NMR studies of protein specificity.

David L. Venezky
10/23/85

PROCEEDINGS OF THE INTERNATIONAL RARE EARTH CONFERENCE NOW IN PRINT

The International Rare Earth Conference (IREC 85), devoted to the fields of materials and chemistry, was held from 4 through 8 March 1985 on the cam-

pus of the Eidgenössische Technische Hochschule (ETH), Hönggerber, Zurich, Switzerland. The highlights of the meeting were the subject of ONR, London, report C-5-85. The proceedings of the conference are now available in *The Journal of the Less-Common Metals*, Volumes 110 (Part 1), 111 (Part 2), and 112 (Part 3). The papers have been grouped thematically under seven subheadings:

Volume 110 (Part 1), August 1985

- Thermodynamics and Phase Diagrams
- Material Synthesis, Structural and Physical Properties

Volume 111 (Part 2), September 1985

- Technology and Industrial Application
- Magnetic Materials, Magnetic Properties
- Physical Properties, Electronic Properties

Volume 112 (Part 3), October 1985

- Optical Properties
- Organometallic, Coordination, Solution and Bioinorganic Chemistry

From the 250 papers announced in the conference's abstract booklet, *IREC 85 Abstracts*, 45 invited and 109 contributed papers are printed in the proceedings.

David L. Venezky
10/23/85

ONRL COSPONSORED CONFERENCES

ONR, London, can nominate two registration-free participants in the conferences it supports. Readers who are interested in attending a conference should write to the Scientific Director, Office of Naval Research Branch Office, Box 39, FPO New York 09510-0700.

Growth Factors in the Nervous System, 24-26 March 1986, Kent, UK.

International Optical Computing Conference, Jerusalem, Israel, 7-11 July 1986.

Sixth International Symposium on Gas Flow and Chemical Lasers, Jerusalem, Israel, 8-12 September 1986.

* * *

ONRL REPORTS

To request reports, indicate the report number on the self-addressed mailer and return it to ONR, London.

- C-11-85 *Quantum Electronics in the UK: A National-Survey Conference*, by Paul Roman. The Seventh National Quantum Electronics Conference met from 16 through 20 September 1985 in Great Malvern, UK. This report highlights presentations on lasers, nonlinear optics, and quantum optics.

- R-6-85 *Immunology Research in Israel*, by Claire E. Zomzely-Neurath. Research in immunology has developed and flourished greatly in Israel. Initially, research in this area was carried out primarily at the Weizmann Institute of Science, Rehovot. In the late 1960s and 1970s, new academic centers were established for immunological research at universities in Tel-Aviv, Haifa, and Be'er Sheva. Important areas in immunology research being pursued by Israeli scientists include investigation of immunoglobulin genes, structure-function analysis of antibodies and regulation of antibody production and expansion; genetics of autoimmunity and cancer; lymphokines and complement; autoimmunity; tumor immunology; transplantation and tissue typing; clinical immunology; infectious diseases; and applied immunology.
- R-7-85 *Summary of European Feedback Control Research*, by Charles J. Holland. Feedback control will continue to be an important research area in Europe as well as internationally. This is not only because of applications in traditional areas, ranging from (perhaps mundane) boiler and industrial control to missile guidance, but also because of newer applications areas in robotics and distributed systems such as flexible space structures. This report covers research on feedback control in The Netherlands, the UK, West Germany, and Sweden.

* * *

SCIENCE NEWSBRIEFS FOR OCTOBER & NOVEMBER

The following issues of *Science Newsbrief* were published by the ONR, London, Scientific Liaison Division during October and November. *Science Newsbrief* provides concise accounts of scientific developments or science policy in Europe and the Middle East. Please request copies, by number, from ONR, London.

<u>Science Newsbrief Number</u>	<u>Title</u>
3-46	New UK Project on Ion-Thruster Space Propulsion, by Paul Roman.
3-48	Eastern-Bloc Scientists Develop Oxide Dispersion Hardened Steels, by Kenneth D. Challenger.
3-49	UK Metal Center Completes Pilot Plant for Making Powders, by Kenneth D. Challenger.
3-50	UK's Culham Lab Starts Long Laser Beam Line Studies, by Paul Roman.
3-51	Mid-Infrared Tunable Single-Mode Lasers--A UK Breakthrough, by Paul Roman.
3-52	Poland's Room-Temperature HgCdTe Detectors Available Through UK Firm, by Paul Roman.

* * *

OCTOBER MAS BULLETINS

The following *Military Applications Summary (MAS) Bulletins* were published by the ONR, London, Military Applications Division during October. The *MAS Bulletin* is an account of naval developments in European research, development, test, and evaluation. Its distribution is limited to offices with the US Department of Defense. DoD organizations should request copies of the *Bulletins*, by number, from ONR, London.

<u>MASB Number</u>	<u>Title</u>
114-85	Airship Industries in UK Wins US Navy Design Study Contract
115-85	EEV Thermal Camera for Firefighting
116-85	Ship Handling Simulator

OCTOBER MAS BULLETINS (CONT'D)

<u>MASB Number</u>	<u>Title</u>
117-85	Small UK Firm Provides Unique Electronic Components for RPVs and Other Military Avionics
118-85	French Naval Material Exhibit in Washington, DC
119-85	Ship Motion Indicator
120-85	European Satellite Oceanography-Information Network
121-85	Seawater Activated Emergency Lights
122-85	Ship Recoverable RPVs Made by Target Technology Ltd.
123-85	Vosper-Thornycroft MCMV Control System

* * *

CHANGE REQUEST
NAVEUR-ONR-5605 1 (Rev. 3-85)

FOR YOUR CONVENIENCE . . .

Government regulations require up-to-date distribution lists for all periodicals. This form is provided for your convenience to indicate changes or corrections. If a change in our mailing lists should be made, or if you want any of the ONRI publications abstracted in this issue and listed below, please check the appropriate boxes. Fold on dotted lines, being sure our address is on the outside, tape or staple the lower edge together, and mail.

- | | | | |
|-----------------------------|---|--------------------------|--------------------------|
| 1. <input type="checkbox"/> | CHANGE OR CORRECT MY ADDRESS
EFFECTIVE IMMEDIATELY OR (date) | <input type="checkbox"/> | <input type="checkbox"/> |
| 2. <input type="checkbox"/> | DELETE MY NAME FROM DISTRIBUTION
LIST | <input type="checkbox"/> | <input type="checkbox"/> |
| 3. <input type="checkbox"/> | PLEASE SEND ME THE FOLLOWING
ONRI PUBLICATIONS | <input type="checkbox"/> | <input type="checkbox"/> |
| | | <input type="checkbox"/> | <input type="checkbox"/> |
| | | <input type="checkbox"/> | <input type="checkbox"/> |
| | | <input type="checkbox"/> | <input type="checkbox"/> |

Corrected or New Address

Fold Here

Fold Here

FROM:

OFFICIAL BUSINESS
PENALTY FOR PRIVATE USE \$300



NO POSTAGE
NECESSARY
IF MAILED
IN THE
UNITED STATES

BUSINESS REPLY MAIL
FIRST CLASS PERMIT NO. 12503 WASHINGTON DC

POSTAGE WILL BE PAID BY DEPARTMENT OF THE NAVY

Commanding Officer
Office of Naval Research, Branch Office
Box 39
FPO New York 09510-0700

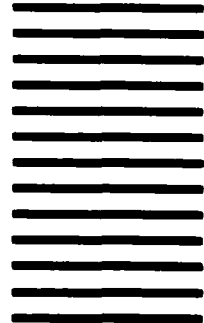

END

FILMED

1-86

DTIC