

AD-A162 037

STUDY OF COLD-CATHODE AND RF-EXCITATION FOR LOW POWER
CO2 WAVEGUIDE LASERS(U) MARYLAND UNIV COLLEGE PARK DEPT
OF ELECTRICAL ENGINEERING U HOCHULT OCT 85

1/1

UNCLASSIFIED

N00014-79-C-0312

F/G 20/5

NL

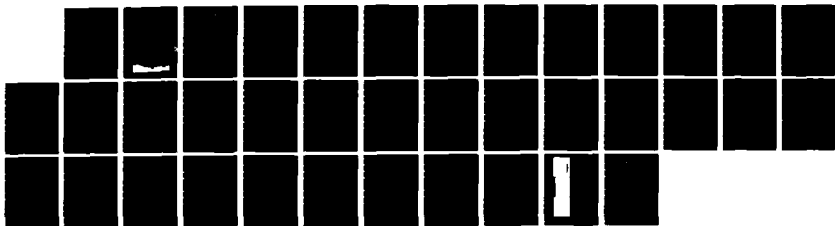

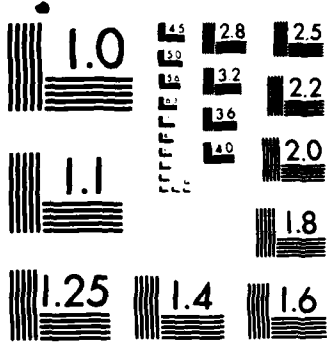

MICROCOPY RESOLUTION TEST CHART
NATIONAL BUREAU OF STANDARDS-1963-A



Electrical Engineering Department

UNIVERSITY OF MARYLAND, COLLEGE PARK, MD 20742

(R) (U)

STUDY OF COLD-CATHODE AND RF-EXCITATION
FOR LOW POWER CO2 WAVEGUIDE LASERS

AD-A162 037

Final Report for ONR Contract
N00014-79-C-0312, A3

by

U. Hochuli

October 1985

DTIC
ELECTE
DEC 3 1985

S D A

This document has been approved
for public release and sale; its
distribution is unlimited.

DTIC FILE COPY



COLLEGE OF ENGINEERING: GLENN L. MARTIN INSTITUTE OF TECHNOLOGY

85 11 26 049

REPORT DOCUMENTATION PAGE		READ INSTRUCTIONS BEFORE COMPLETING FORM
1. REPORT NUMBER	2. GOVT ACCESSION NO. AD-A13037	3. RECIPIENT'S CATALOG NUMBER
4. TITLE (and Subtitle) Study of Cold-Cathode and RF-Excitation for Low Power CO ₂ Waveguide Lasers		5. TYPE OF REPORT & PERIOD COVERED Final Report
7. AUTHOR(s) U. Hochuli		6. PERFORMING ORG. REPORT NUMBER
9. PERFORMING ORGANIZATION NAME AND ADDRESS Electrical Engineering Department University of Maryland College Park, MD 20742		8. CONTRACT OR GRANT NUMBER(s) N00014-79-C-0312
11. CONTROLLING OFFICE NAME AND ADDRESS ONR		10. PROGRAM ELEMENT, PROJECT, TASK AREA & WORK UNIT NUMBERS G1153N RR011-07-04 NR 379-042
14. MONITORING AGENCY NAME & ADDRESS (if different from Controlling Office)		12. REPORT DATE October 1985
		13. NUMBER OF PAGES 34
		15. SECURITY CLASS. (of this report) Unclassified
		15a. DECLASSIFICATION/DOWNGRADING SCHEDULE
16. DISTRIBUTION STATEMENT (of this Report) Approved for public release; distribution unlimited		
17. DISTRIBUTION STATEMENT (of the abstract entered in Block 20, if different from Report)		
18. SUPPLEMENTARY NOTES		
19. KEY WORDS (Continue on reverse side if necessary and identify by block number) CO ₂ waveguide lasers; 2 W CW; Lifetest results; RF excitation; electrode and electrode-less; CO and N ₂ mixtures; On-off switching life; RF gas conductance and starting voltage measurements.		
20. ABSTRACT (Continue on reverse side if necessary and identify by block number) Initial results indicate that transversely RF excited 2W CW CO ₂ waveguide lasers can be built to last in excess of 10 ⁴ hours. This result has been achieved with either internal electrodes or capacitive wall coupling and with either CO- or N ₂ -bearing gas mixtures. On-off switching seems to be quite well tolerated. RF conductance and starting voltage measurements for six different gas mixtures and four pressure parameters are given.		

STUDY OF COLD-CATHODE AND RF-EXCITATION FOR LOW POWER CO₂ WAVEGUIDE LASERS

ABSTRACT

Longitudinal DC excitation with cold cathodes has produced low pressure 1W CW CO₂ lasers with a life in excess of 20,000 hrs. Similar life time performance for the longitudinal DC excited waveguide CO₂ laser has thus far not been achieved in our laboratory or published in the open literature.

Initial results indicate that transversely RF excited 2W CW CO₂ waveguide lasers can be built to last in excess of 10⁴ hours. This result has been achieved with either internal electrodes or capacitive wall coupling and with either CO- or N₂-bearing gas mixtures.

INTRODUCTION

The use of proper cold cathodes for the low pressure 1W CW CO₂ laser has extended the average life of this laser to over 20,000 hours [1,2]. This result required CO bearing gas mixtures and could at that time not be duplicated for gas mixtures with N₂ content. Only quite recently have promising results been reported for the latter type of mixture [3]. With these findings, it seemed quite natural to attempt to extend the cold cathode technology to the 100 torr pressure range required for the CO₂ waveguide laser.

DC EXCITATION

From the published guidelines [1] it is not too difficult to find cold cathode materials that work with CO bearing gas mixtures. However, the larger pressure required for the waveguide CO₂ laser leads to much larger cathode current densities, as can be seen from our measurements shown in Figure 1. Such cathodes can maintain quite reasonable composition ratios of CO-bearing gas mixtures over periods in excess of 10⁴ hours. A much more serious problem seems

to be the fact that in the 100 torr pressure range most cathode materials produce sputtering products that are not very well attached to the surfaces they settle on. Lasers containing such loose grains and flakes may perform reasonably well in the laboratory but are certainly not viable candidates for field use. Another very serious, and in test discharge tubes not easily observable, problem seems to occur from material transport in the gaseous phase. We have observed this process with copper cathodes. Waveguide lasers with such cathodes and internal mirrors close to the bore ends usually last for less than 10^3 hours, while test discharge tube results indicate that laser life should be better than 10^4 hours. A short pump-down and gas refill does little to restore the original output power. Extensive pump down periods of 24 hours, somewhat less if the laser body is heated to 100°C , followed by a refill with new gas usually restores the laser to its original power output. Observation of the mass spectrum during evacuation does not seem to reveal any products that are not already in the gas mixture except for a small amount of H_2O . The laser behaves as if material transport is taking place which creates mirror deposits of a relatively volatile nature. One can speculate that perhaps copper carbonyl may be created. The existence of such a carbonyl seems to be fairly controversial [4]. The very good results published to date for copper cold cathodes [5] seem to depend on optical surfaces that are relatively far away from the discharge.

The cathode temperature is an additional parameter that has to be carefully controlled. For Cu and Ni cathodes we have experimentally observed critical cathode temperatures of about 600°C and 800°C , respectively. At or above this temperature, the cathode current density suddenly decreases by perhaps a factor of five. This result is probably caused by a sufficiently rapid reduction of the surface oxides by the CO-CO_2 bearing gas mixture. Discharge tubes working

with cathodes at these elevated temperatures show relatively little sputtering and no flaky deposits. In order to reach these critical temperatures, it is necessary to use additional heating elements in the cathode or to drastically reduce the cathode size so that it self heats. Both of these solutions are impractical.

Attempts to reduce cathode sputtering by increasing the electrical conductivity of the oxide layer formed at the cathode through valency control [6,7] have only been partially successful. Our sintered Ag cathodes with 5 molecular percent of Li_2O have worked in a one watt waveguide laser for 9500 hours. About 70% of the original power output remained after this period of time. Little sputtering was visible outside of the cathode and all of it seemed to be in form of a transparent, well attached, film. Considerably more sputtering took place inside the hollow cathode. Mirror damage was far more extensive on the output mirror that had a dielectric top layer of ZnS. The totally reflecting mirror with its silver layer protected by ZnSe was in much better condition at the end of the experiment.

RF EXCITATION

We have found it to be considerably easier to build transversely RF excited CO_2 waveguide lasers with an acceptable life than the longitudinally, cold cathode, DC excited version.

The typical cross sectional geometry of the lasers tested is shown in Figure 2. Additional construction details and parameters are listed in Table I. All of the lasers built have proper high vacuum seals and no epoxy resin was used. Indium, used in some of the seals, limits the maximum outgassing temperature of the structures to 120°C . Excitation of each laser is achieved by a 30 W RF transmitter, working at 140 MHz, through a matching network. The network consists of a π section followed by a helical auto-transformer next to the

laser and has an efficiency of about 85 percent. Results of RF-conductance measurements of the laser plasma for different gas mixtures are given in the Appendix.

The initial laser power output was between two and three watts, measured on the highest peak of the signature. No attempt was made to change the nominal 6 percent output coupling mirror to achieve greater output power.

ELECTRODE MATERIALS

RF power for the laser shown in Figure 2 is capacitively coupled from an electrode on the outside top of the waveguide through the 0.4mm thick BeO top wall of the waveguide into the interior plasma. The bottom electrode is formed by the water-cooled metal block that serves as the lower portion of the waveguide. This metal block was modified such that a number of different electrode material sections could be inlaid. This allowed us to quickly test the suitability of a number of electrode materials simultaneously. The following materials were tested: Pt, 304 SS, Au, Cu, Ag and Ni. Visual inspection after 3000 hours of service in the CO-bearing mixture showed almost no change in the appearance of Pt, some discoloration of the 304 SS and unacceptable deposits on the other materials. The Ni had sputtered so badly that even the BeO section of the waveguide was black. Repetition of the test in a N₂-bearing mixture produced practically identical results. The laser shown in Figure 2 could be transformed into a totally capacitively coupled structure without internal electrodes by sliding a 0.18mm thick BeO leaf between the BeO waveguide and the bottom metal block.

Accession For		
NTIS CRA&I		<input checked="" type="checkbox"/>
DTIC TAB		<input type="checkbox"/>
Unannounced		<input type="checkbox"/>
Justification		
Availability Codes		

4

QUALITY
CONTROLLED
3

A-1

LASER LIFE WITH RF EXCITATION

The four best results achieved so far out of a total of eight lasers are shown in Figures 3 to 6. It should be mentioned that the lasers tested had no length control other than the cooling water temperature. Consequently the lasers drifted around within their signatures. Their average power was about half the maximum obtainable through length adjustment. The results shown are therefore not an indication that the mirrors can tolerate maximum power output continuously over the periods indicated.

ON-OFF CYCLING

Laser #1 worked for 7000 hours and failed as a result of He loss. A very small leak was found to be the cause for the failure. After the leak was sealed the laser was refilled without cleaning or rebuilding. The laser was then designated as laser #1.1 and operated with 5 minute on-5 minute off cycles. Its power output, recorded over 50,000 such cycles, is shown in Figure 7. The laser was then evacuated and refilled with new gas. This restored its power output back to the value it had before cycling began. From this result we can conclude that cycling the laser did not cause any serious additional damage to the internal mirrors which were only 13 mm away from the discharge.

CONCLUSIONS

An ideal excitation method for a CO_2 waveguide laser should not only be cheap and yield a very long laser life, it should also be a method that:

- a) can be easily and reliably applied by others;
- b) is sufficiently tolerant in its parameters to be practical;
- c) leads to a final product that can survive field and not just laboratory tests;
- d) can be extrapolated to higher power levels without further major research effort;

e) can function with N_2 - and CO-bearing mixtures.

Currently, we have not been able to find cold cathode materials for DC excitation that satisfy a sufficient number of these criteria. RF excitation, however, may eventually satisfy most and perhaps all of them. Our results show that transversely RF excited 2W CW CO_2 waveguide lasers can be built that last in excess of 10^4 hours. So far, insufficient statistical results are available to predict the average life of a large number of this type of laser.

However, it is very encouraging that similar results could be obtained for excitation with either internal electrodes or through capacitive wall coupling and with either CO- or N_2 -bearing mixtures. Even a large number of on-off cycles seem to be tolerated quite well by this type of laser.

A considerably larger effort has been made in our laboratory using longitudinal cold-cathode DC excitation, but all of the results were inferior to the results achieved with RF excitation. It remains to be seen if other cold cathodes, designed for N_2 -bearing CO_2 waveguide lasers [8,9], can satisfy a sufficient number of the criteria mentioned.

ACKNOWLEDGEMENTS

This work was initially supported by the National Science Foundation and received continuing support from the Office of Naval Research, the Air Force Office of Scientific Research, and the National Aeronautics and Space Administration. The RF measurements in the Appendix could not have been performed without access to one of Westinghouse's network analyzers.

REFERENCES

- [1] U.E. Hochuli and T.P. Sciacca, Jr., "Cold Cathodes for sealed-off CO_2 Lasers", J.Q.E., Vol. 10, pp. 239-244, 1974.
- [2] Final Report for NASA Grant NSG5042, April 1981.

- [3] N. Karube, N. Iehisa, K. Fukaya and K. Matsuo, "Sealed-off CO₂ Lasers with La_{1-x}Sr_xCoO₃ Oxide Cathodes", Appl. Phys. Letters, Vol. 43, pp. 1086-8, December 1983.
- [4] Gmelins Handbuch der Anorganischen Chemie, Kupfer, Teil D, Verlag Chemie, GMBH, Weinheim.
- [5] L.M. Laughman, "Long Term Operation of a Sealed Waveguide CO₂ Laser" Rev. Sci. Instrum. Vol. 47, pp. 1411-13, November 1976.
- [6] E.J.W. Verwey, P.W. Haaijman, F.C. Romeijn, and G.W. van Oosterhout, "Controlled-Valency Semiconductors", Philips Res. Rep. 5, pp. 173-187, 1950.
- [7] S. Pizzini, R. Morlotti, and V. Wagner, "Study of the Lithium Oxide - Nickel Oxide System," J. Electrochem. Soc., Vol. 116, pp. 915-20, July 1969.
- [8] A.L.S. Smith, H. Shields, and A.E. Webb, Cathode Materials for Sealed CO₂ waveguide Lasers", J-QE, Vol. 12, pp. 815-20, May 1983.
- [9] P. Pace and J. Cruishank, "Long Term Operation of a Sealed Waveguide CO₂ Laser", Rev. Sci. Instrum., Vol. 52, pp. 1493-6, October 1981.

APPENDIX

RF IMPEDANCE MEASUREMENTS

These measurements are intended to furnish data that will serve as a basis for the matching and starting network calculations.

TEST PROCEDURES

The actual laser discharge is first matched with a helical auto-transformer and π -network to the 50 ohm line. Matching is achieved by adjusting the π -network until the apparent SWR on the slotted line is better than 1.01 for each given input power level. Figure 8 shows the equipment used for this measurement. The auto-transformer is then removed from the laser and attached to a test fixture that closely duplicates the laser structure and brings the driving point connection out through the HP 11566A 10 cm precision airline as shown in Figure 9.

Both the π -network and 10 cm airline have APC-7 precision connectors that serve as the two reference planes for the S-parameter measurements. These measurements were performed on one of Westinghouse's HP 8510 network analyzers. We greatly appreciated the use of this facility.

The four S-parameters allow one to calculate the efficiency, driving point voltage, and impedance of the network at the input power level that the network was tuned for. Figures 10 to 15 show curves of the input conductance versus power for six different gas mixtures with four pressure parameters. Transmission line theory can be used to calculate the local gas conductance.

The calculated voltage is then used to calibrate the voltage measured with the the probe of an HP 8405A vector voltmeter. This probe is coupled through stray capacitance to the driving point of the laser as indicated in Figure 9. This calibrated probe can now be used to measure the voltage required for starting

the discharge. Figures 16 to 21 show this starting voltage and the minimum transmitter power required to spread the discharge over the full bore length for different pressures and gas compositions. The gas discharge itself receives only about 85 percent of the transmitter power because of coupling network losses.

MEASUREMENT ACCURACY

We have varied each one of the amplitudes and phases individually in order to determine how much S-parameter amplitude and phase errors affect the calculated load impedance and network efficiency. Data for variations around a set of four typical S-parameters is presented in Table 2. These results show that the S_{21} parameter amplitude accuracy is extremely important. Our variation of 0.1 db is realistic and perhaps even optimistic in view of the fact that the National Bureau of Standards is capable of measuring S_{12} and S_{21} parameters with 0.03 db and S_{11} and S_{22} parameters with 0.05 db accuracy. The network analyzer's source mismatch and a network that has to be measured under almost totally reflecting conditions are the main causes for this error.

It can be shown that errors caused by the remaining SWR after tuning the networks are less important.

We have also measured the current waveform through a test discharge tube. The tube was designed with two parallel, 20 mm long, 1.5 mm nickel wire electrodes, with 3.5 mm center-to-center spacing. Its gas filling consisted of 125 torr He:CO₂:CO:Xe in the ratios 3:1:1:0.25. A parallel inductance tuned out the capacitive current through the 2 pf electrode capacitance.

The 70 MHz discharge current waveform is shown in Figure 22 and clearly indicates some distortion in the peaks. Figure 22 also shows that this, mostly odd order, harmonic distortion is not present in the transmitter output. Because of this inherent distortion, it does not make sense to spend a great

deal of effort to further reduce the network analyzer errors.

NETWORK EFFICIENCY

Lack of impedance data forced us to design our network empirically. Our choice of reasonably good components generally resulted in network efficiencies on the order of 85 percent. We have also found that we sometimes had large circulating currents that lowered the efficiency to 70 percent or less. This result was not simply due to network analyzer error as there was a substantial temperature rise of some of the network components. In one instance, this temperature rise was sufficient to discolor and oxidize the tin-plated copper coil in the π -network. The input power used was only 30 watts at 140 MHz. This result should serve as a warning that an improperly designed network, placed inside the laser and surrounded by the gas mixture, can actually reduce the laser life by consuming oxygen for its oxidation.

We have found that minor design changes, such as varying the tap of the auto-transformer by a fraction of a turn, can improve the efficiency to an acceptable value. It should also be noted that improper tuning of the networks can result in discharges outside of the laser bore or feeding all of the RF power into half of the laser's length.

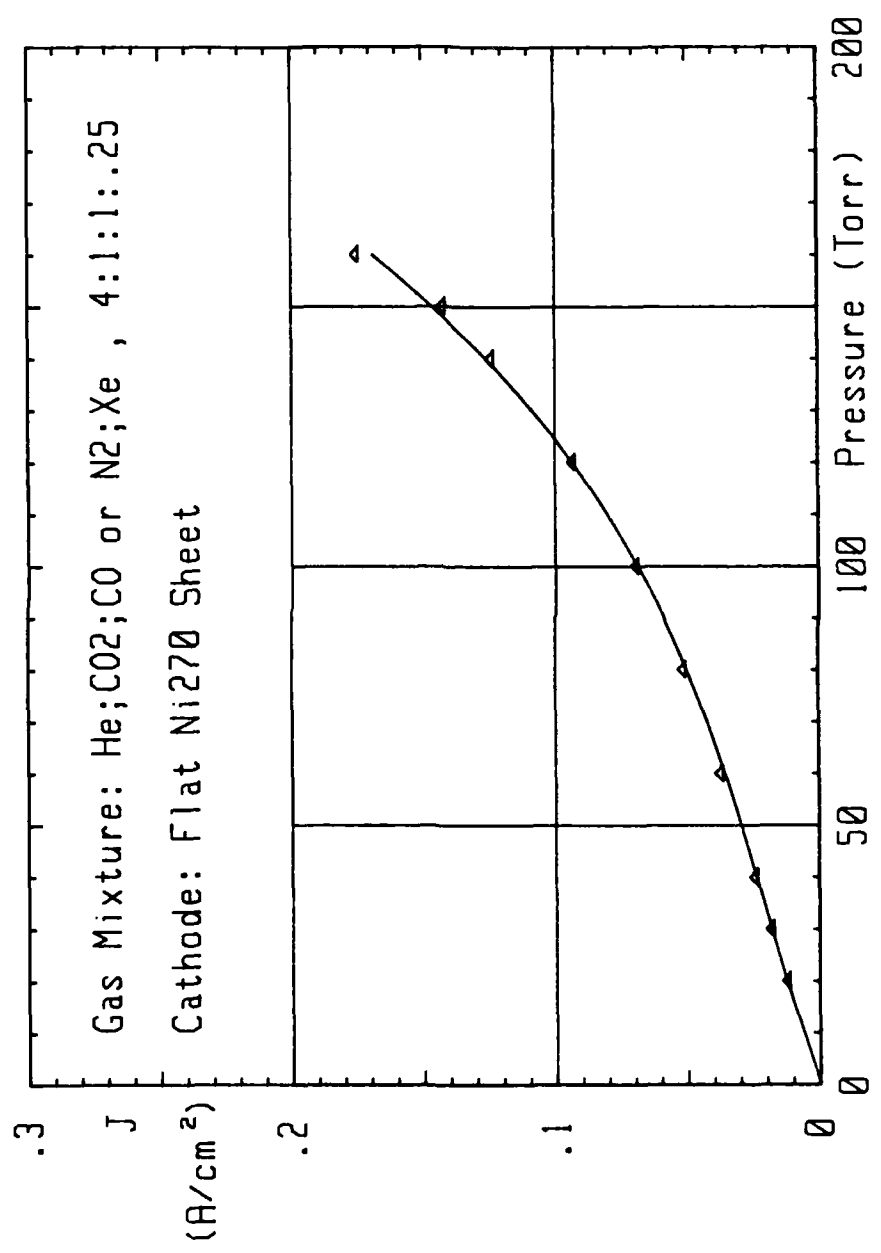

Fig.1, Normal Cathode Current Density vs Pressure

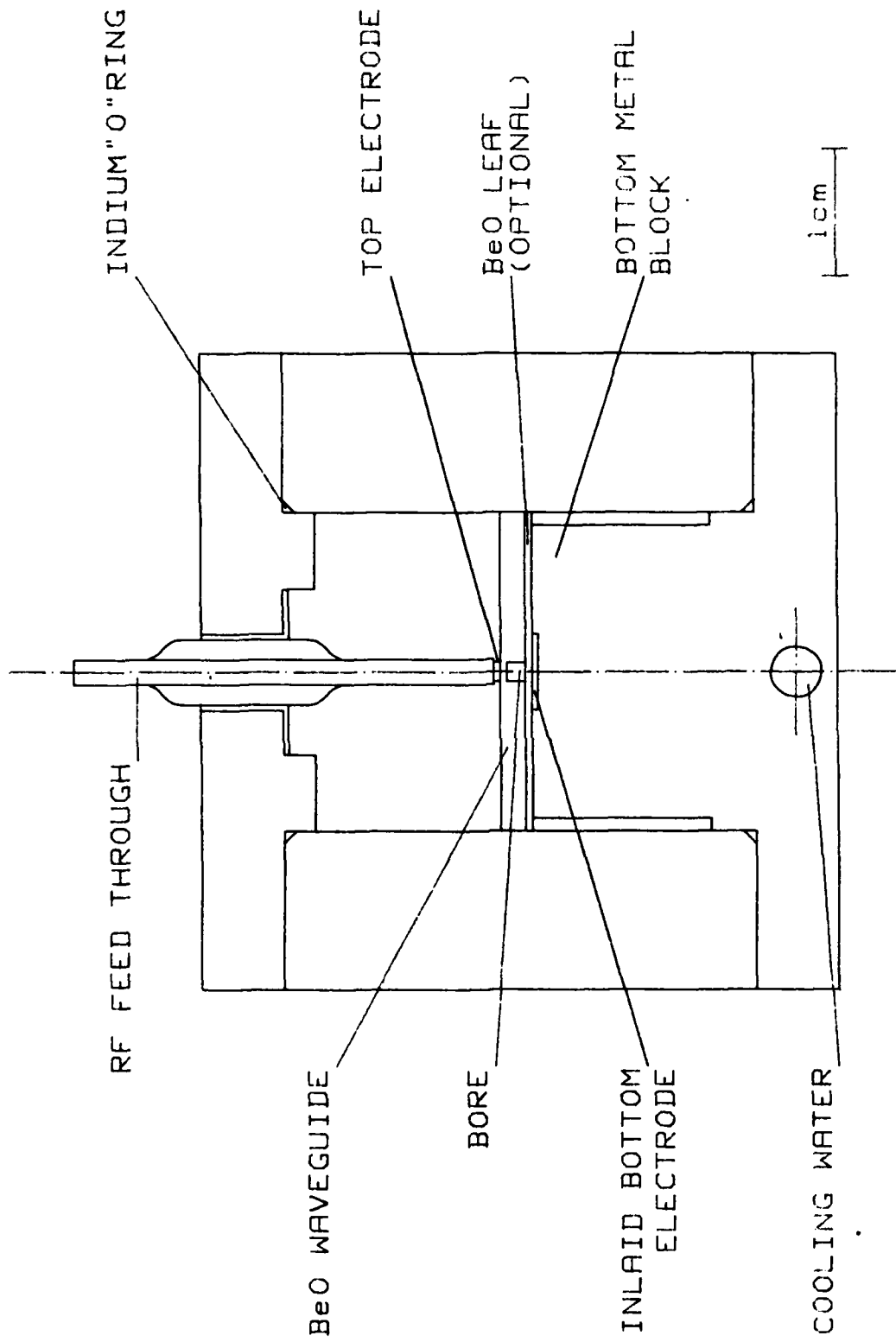

Fig.2, Laser Cross Section

Laser #2

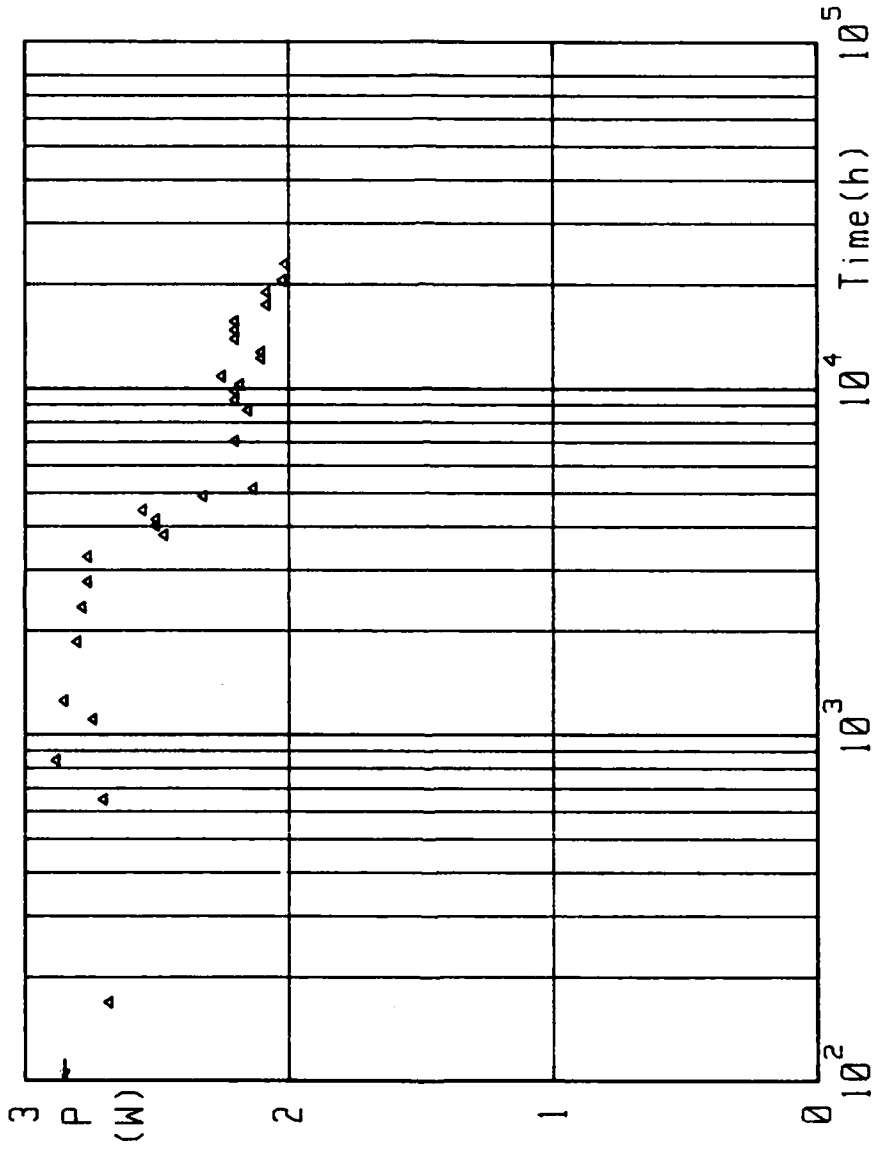

Fig.3 , Output Power vs Time

Laser #6

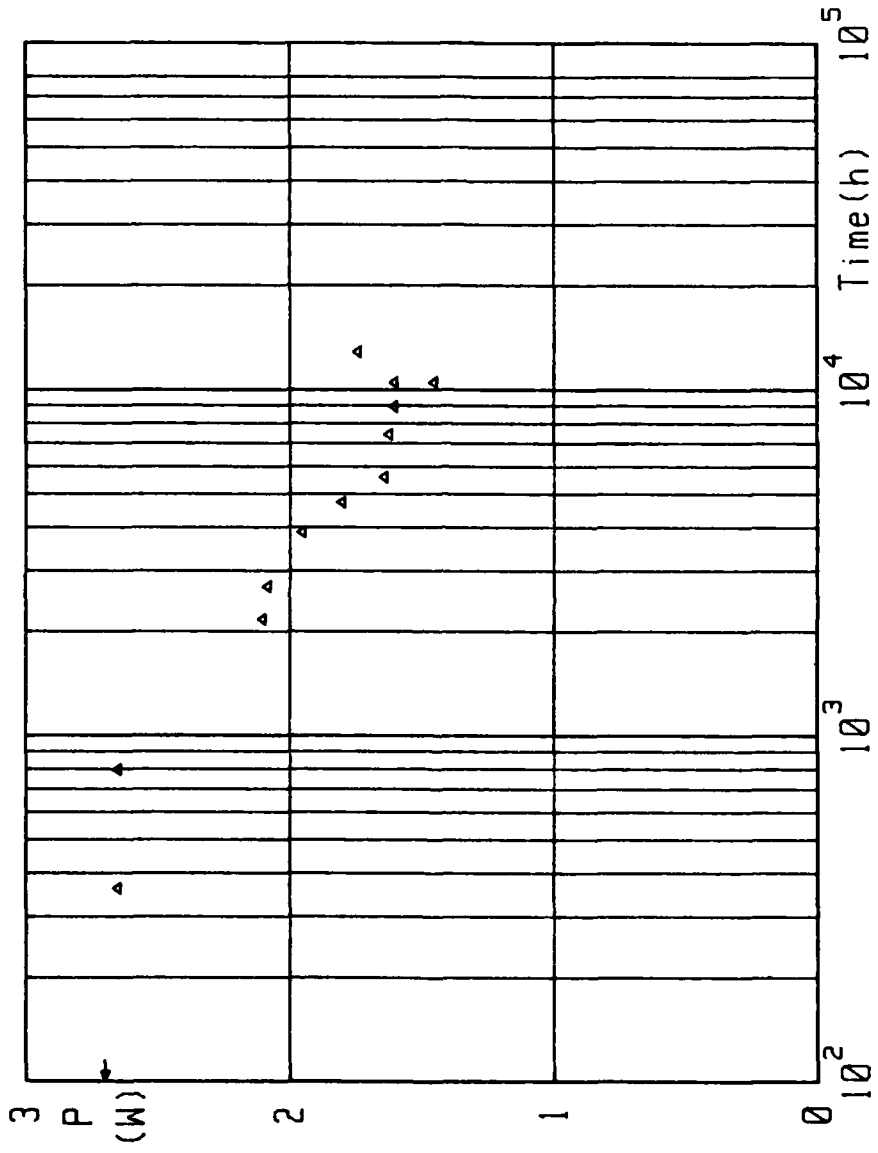

Fig. 4 , Output Power vs Time

Laser #9

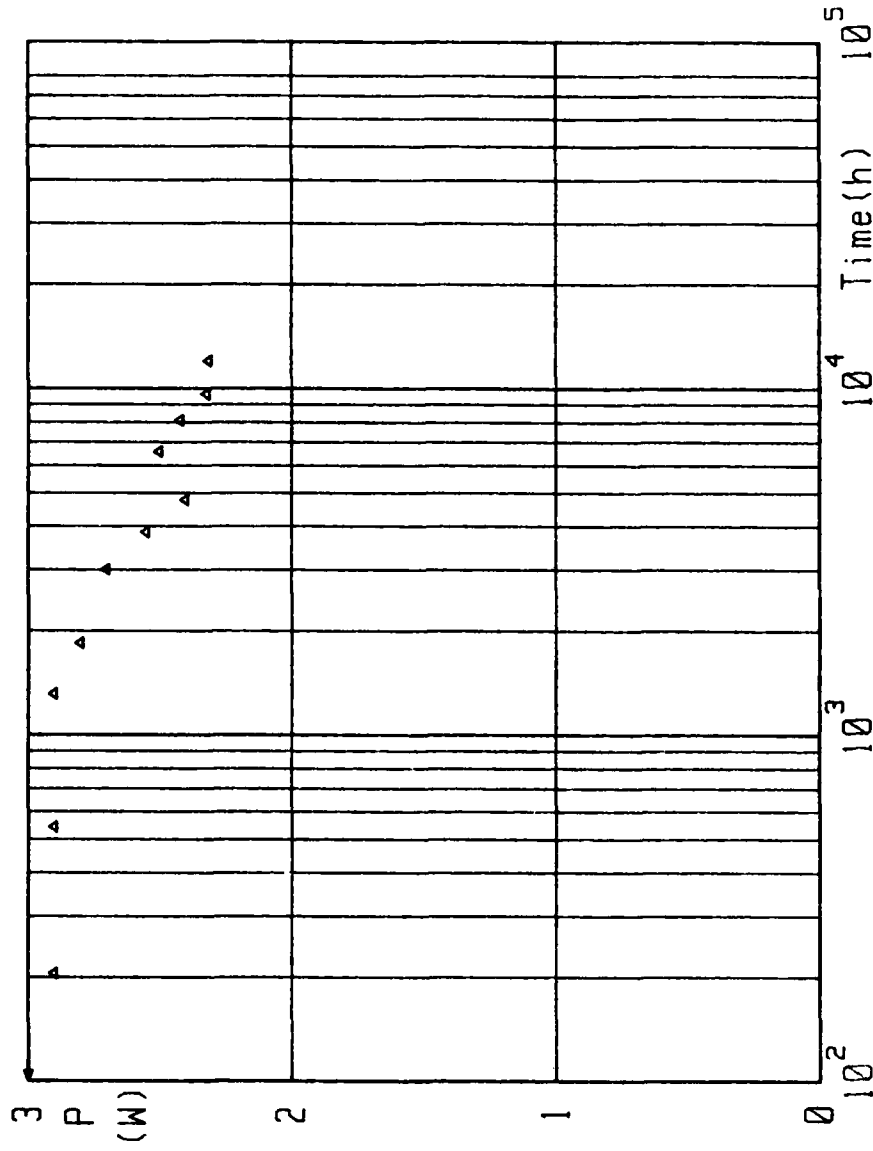

Fig.5 , Output Power vs Time

Laser #10

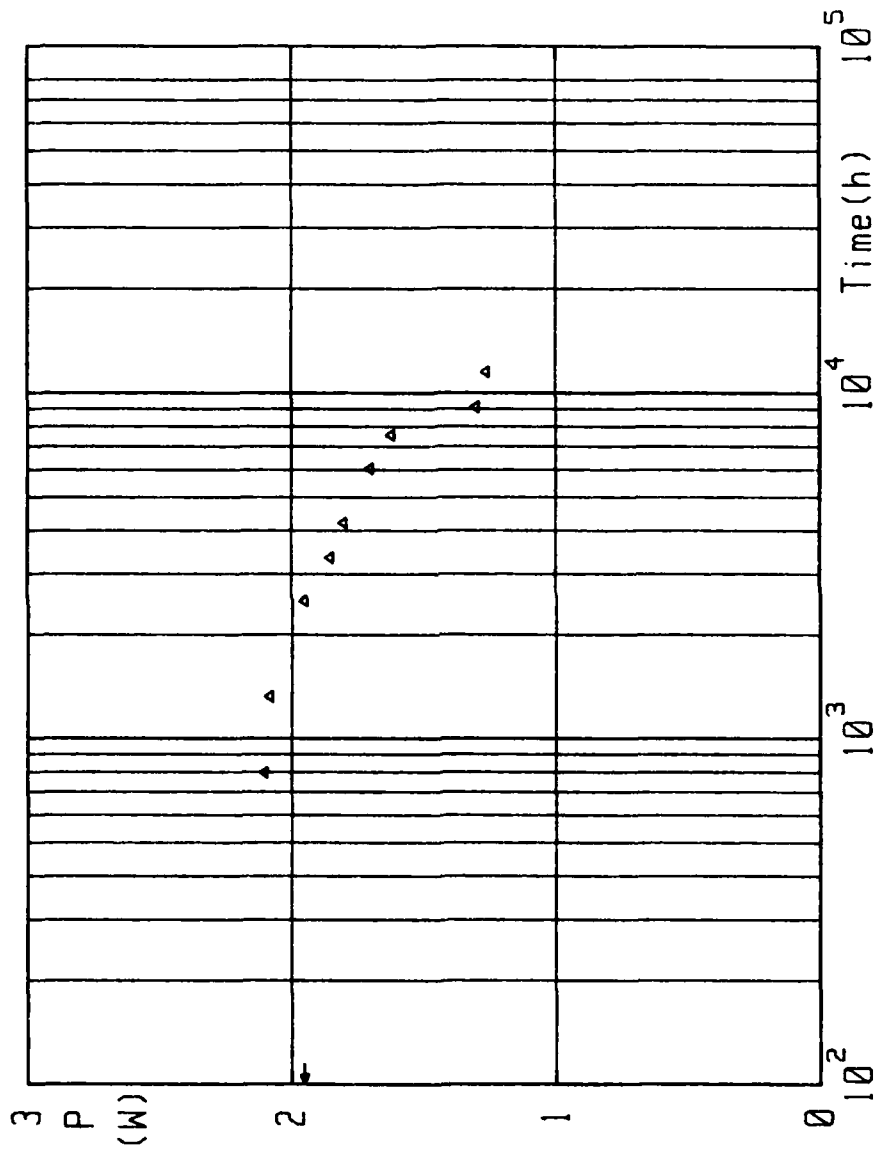

Fig. 6 , Output Power vs Time

Laser #1.1

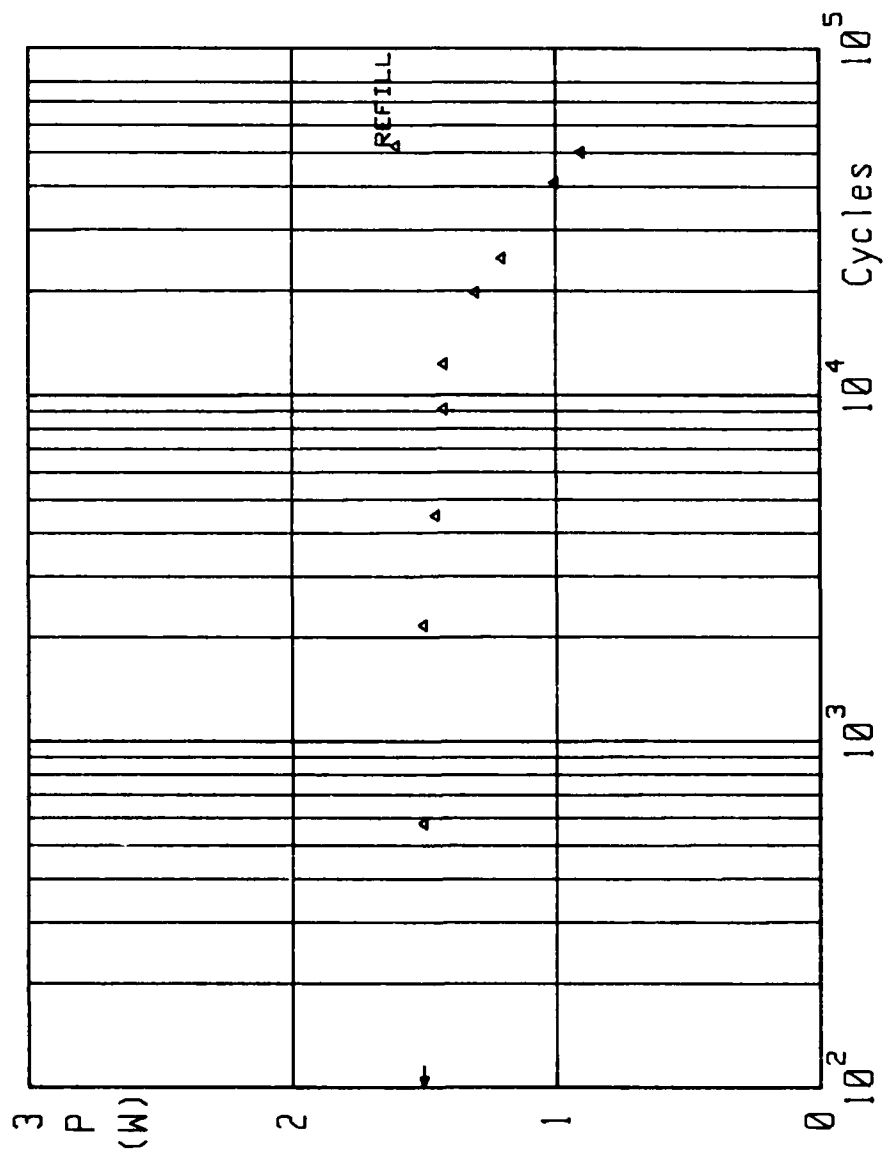

Fig.7 ,Power Output vs # of Cycles (5 min.ON,5 min.OFF)

TABLE 1

LASER	HOUSING MATERIAL	TOP- "ELECTRODE"	BOTTOM- "ELECTRODE"	GAS-MIXTURE					OUTPUT- MIRROR	REMARKS
				He	CO ₂	CO	N ₂	Xe		
# 1.1	Cu	BeO	Pt	3	1	1	0	.25	.94 at 9.6μ	Cycled # 1
# 2	Cu	BeO	Pt, 4%Cu	3	1	1	0	.25	.94 at 9.6μ	
# 6	Au plated Cu	BeO	BeO leaf	3	1	1	0	.25	.94 at 10.6μ	
# 9	303 SS	BeO	Pt	3	1	.5	1	.25	.935 at 10.6μ	
# 10	303 SS	BeO	BeO leaf	3	1	.5	1	.25	.934 at 10.6μ	

RF Excitation: 30 W at 140 MHz

Laser bore: 1.5mm wide, 1.65mm high, 152.4mm long, 127mm excited

Internal mirror spacing 153mm, dielectric total reflector on Si, coated ZnSe output coupler (III-VI)

Gas volume 100cc, pressure 120 Torr

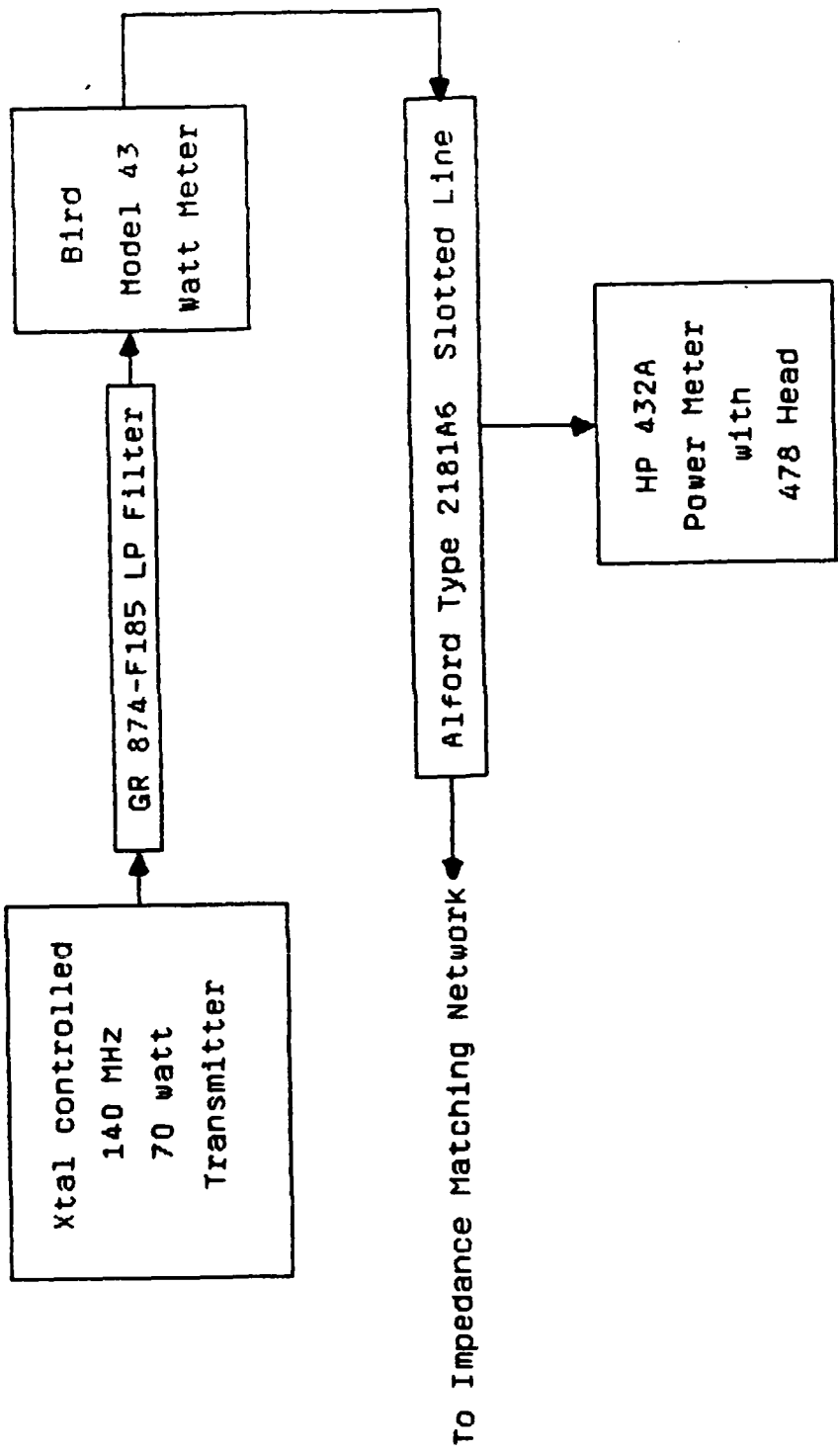
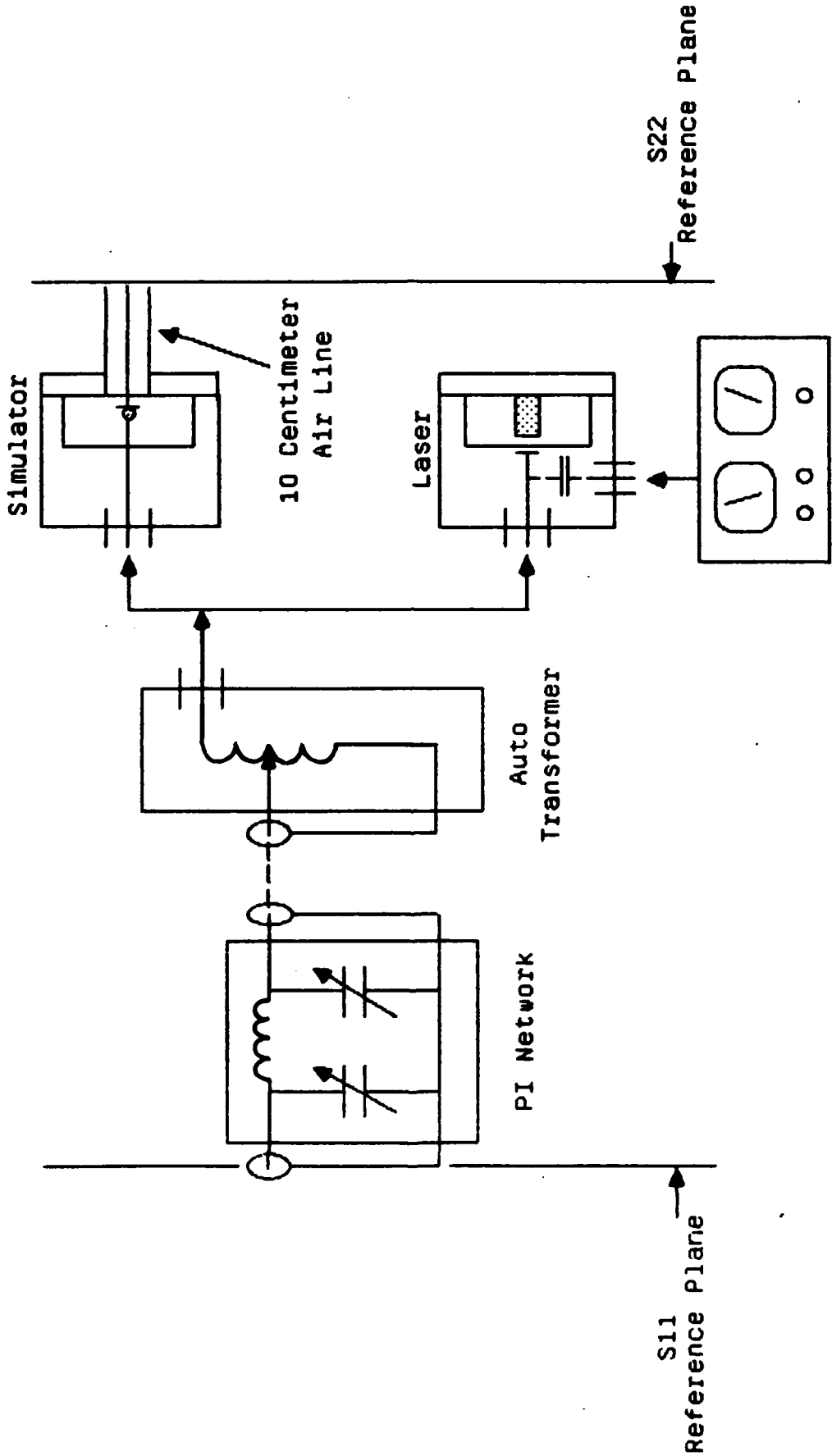

Figure 8. Equipment configuration for SWR measurement

Plasma Impedance Measurement



HP 8405A vector Voltmeter

Figure 9, Experimental Setup

He:CO₂:CO:Xe ; 3:1:1:.25

Laser bore: 1.5mm wide, 1.65mm high, 152.4mm long, 127mm center-excited at 140 MHz

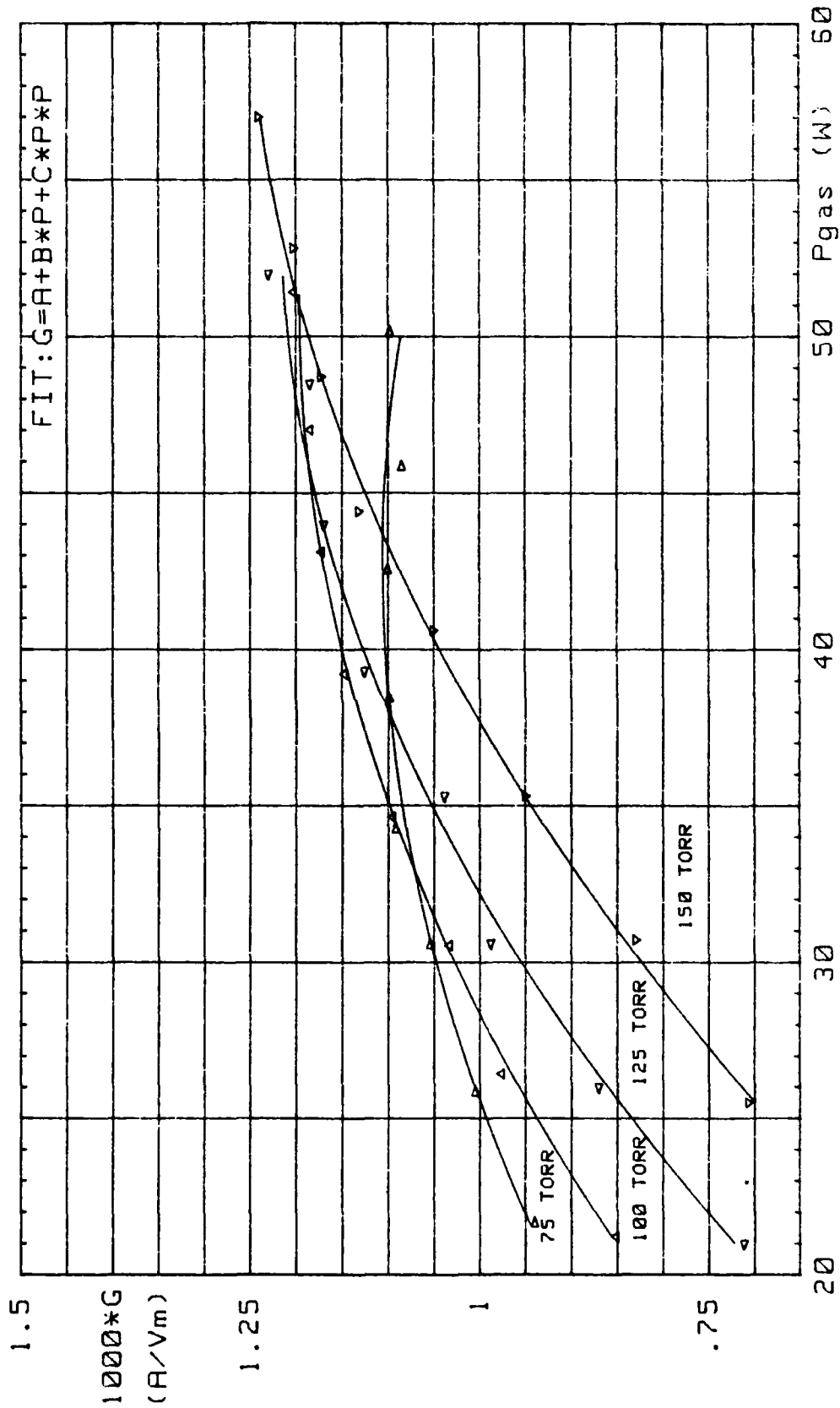

Fig. 10, CENTER RF-CONDUCTANCE VS RF-POWER

He:CO₂:N₂:Xe ; 3:1:1:.25

Laser bore:1.5mm wide,1.65mm high,152.4mm long,127mm center-excited at 140 MHz

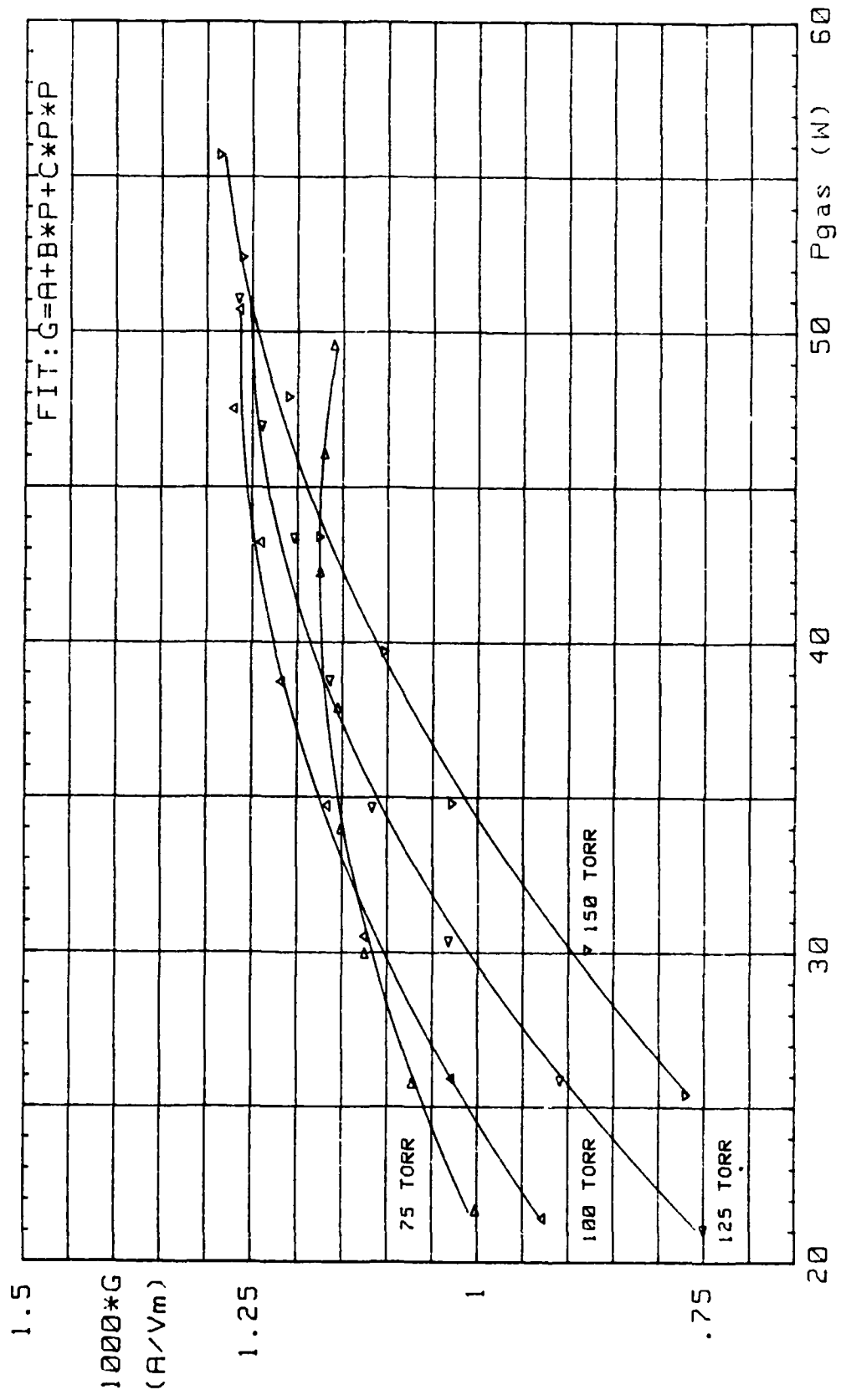

Fig. 11, CENTER RF-CONDUCTANCE VS RF-POWER

He:CO₂:CO:Xe ; 4:1:1:.25

Laser bore:1.5mm wide,1.65mm high,152.4mm long,127mm center-excited at 140 MHz

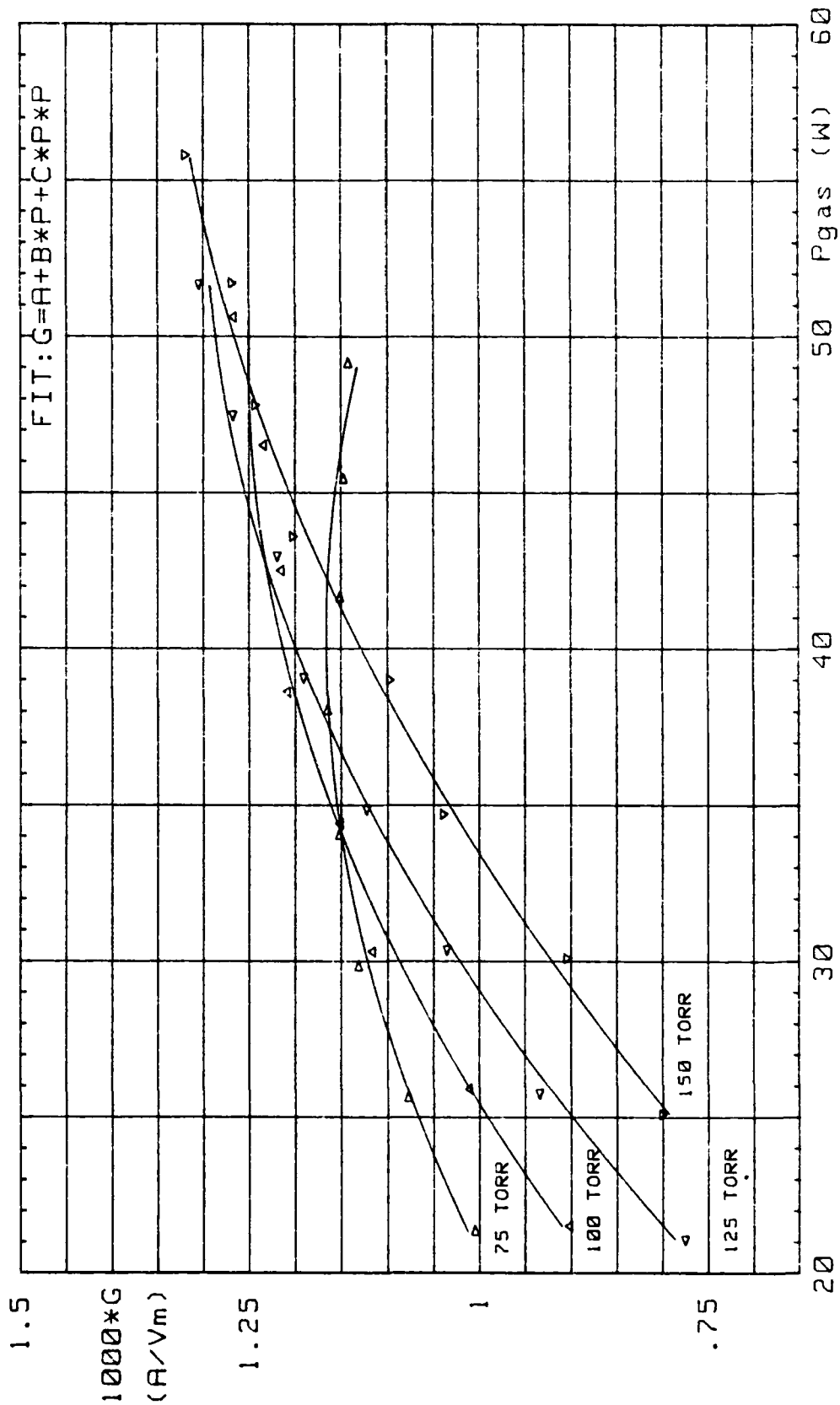

Fig. 12, CENTER RF-CONDUCTANCE VS RF-POWER

a

He:CO2:N2:Xe ; 4:1:1:.25

Laser bore:1.5mm wide,1.65mm high,152.4mm long,127mm center-excited at 140 MHz

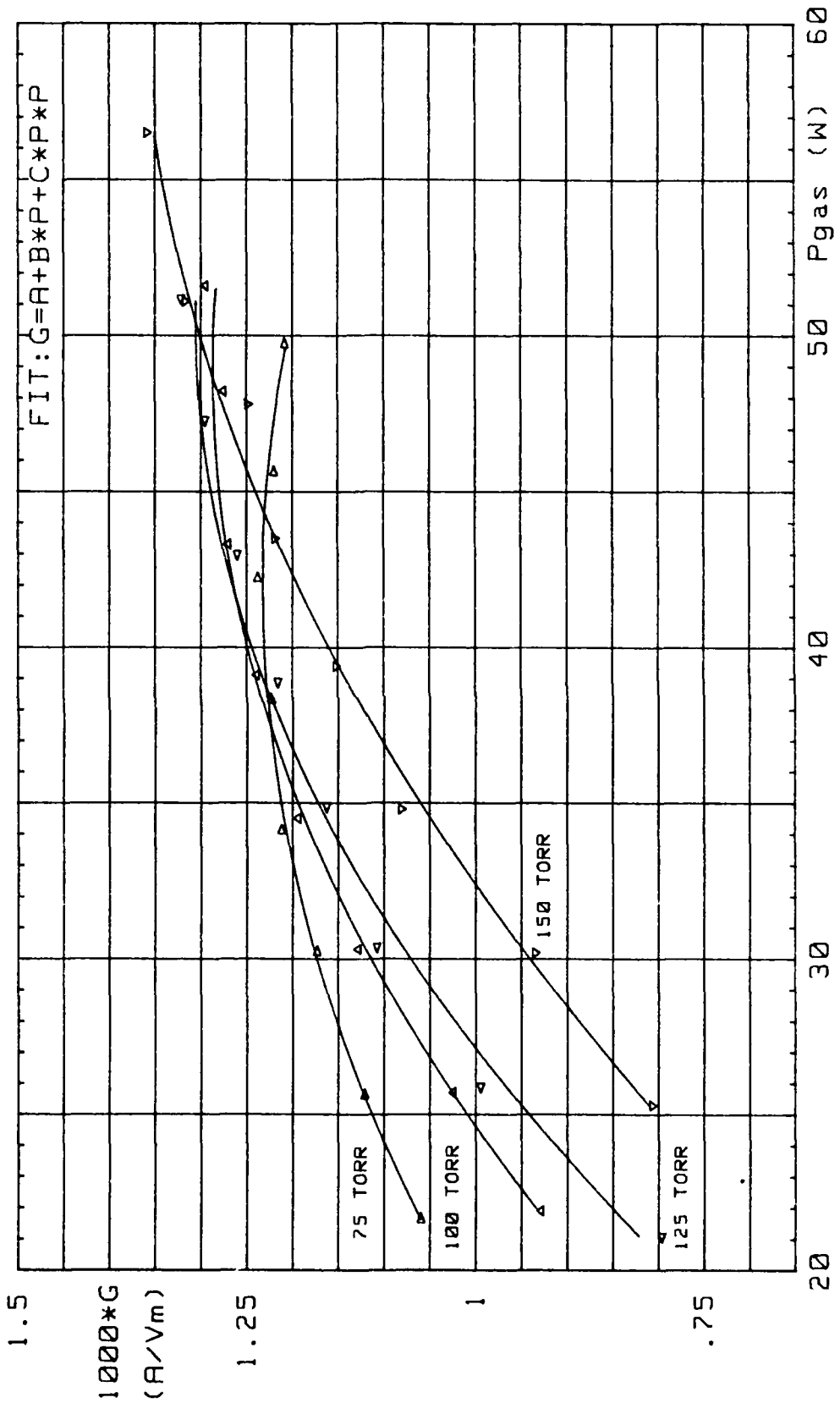

Fig. 13, CENTER RF-CONDUCTANCE VS RF-POWER

He:CO₂:CO:Xe ; 5:1:1:.25

Laser bore:1.5mm wide,1.65mm high,152.4mm long,127mm center-excited at 140 MHz

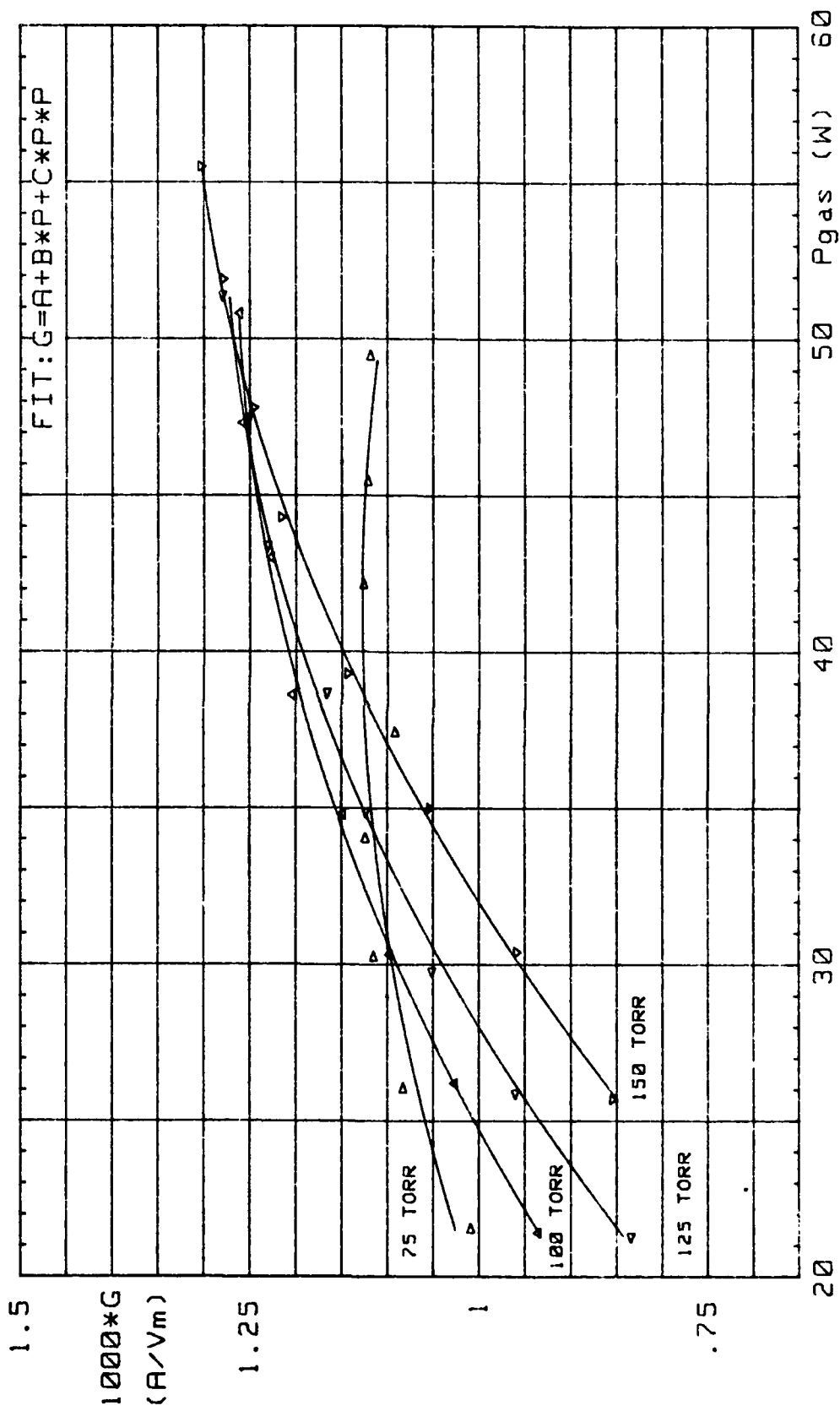

Fig. 14, CENTER RF-CONDUCTANCE VS RF-POWER

He:CO₂:N₂:Xe ; 5:1:1:.25

Laser bore:1.5mm wide,1.65mm high,152.4mm long,127mm center-excited at 140 MHz

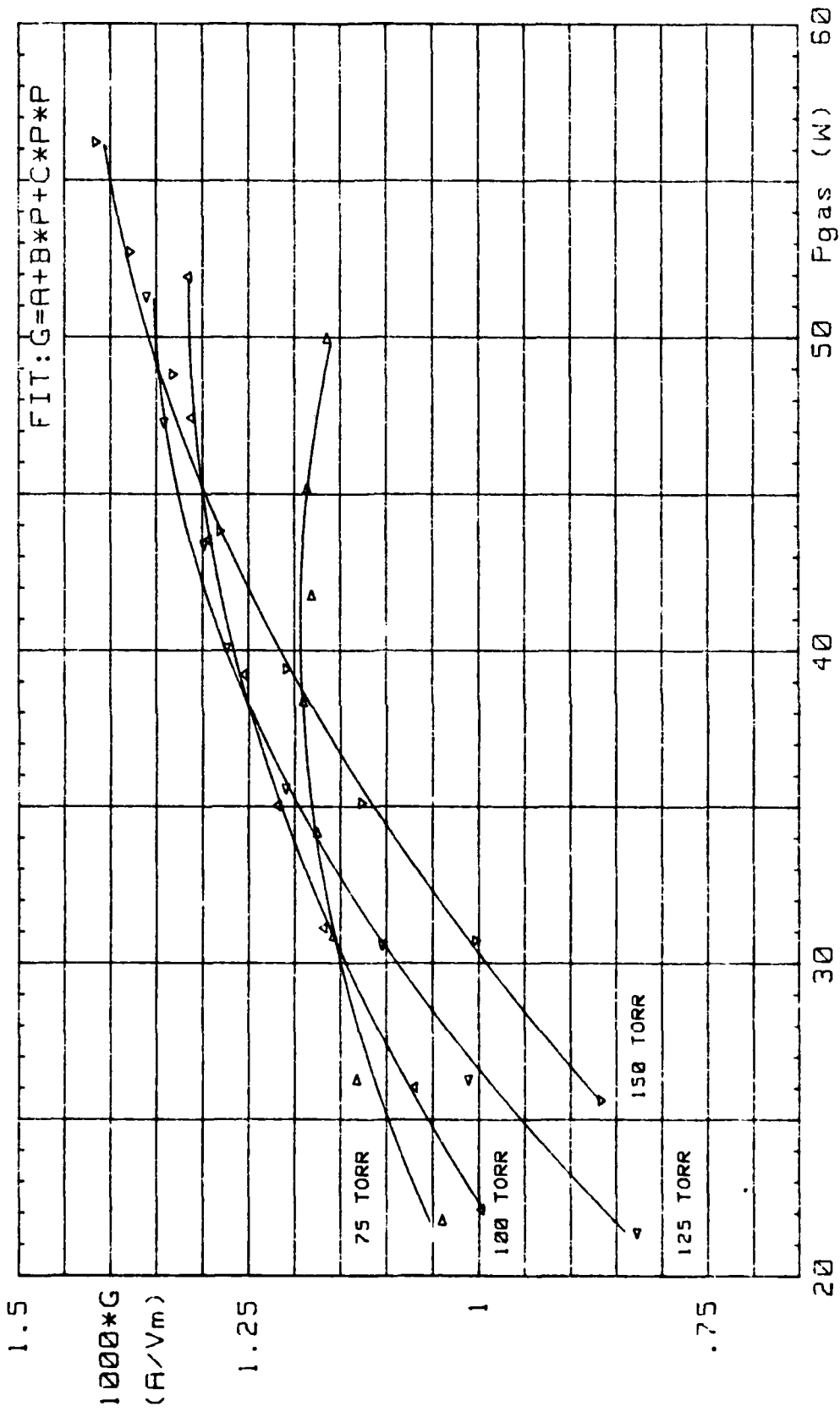

Fig.15, CENTER RF-CONDUCTANCE VS RF-POWER

He:CO₂:CO:Xe ; 3:1:1:.25

Laser bore:1.5mm wide,1.65mm high,152.4mm long,127mm center-excited at 140 MHz

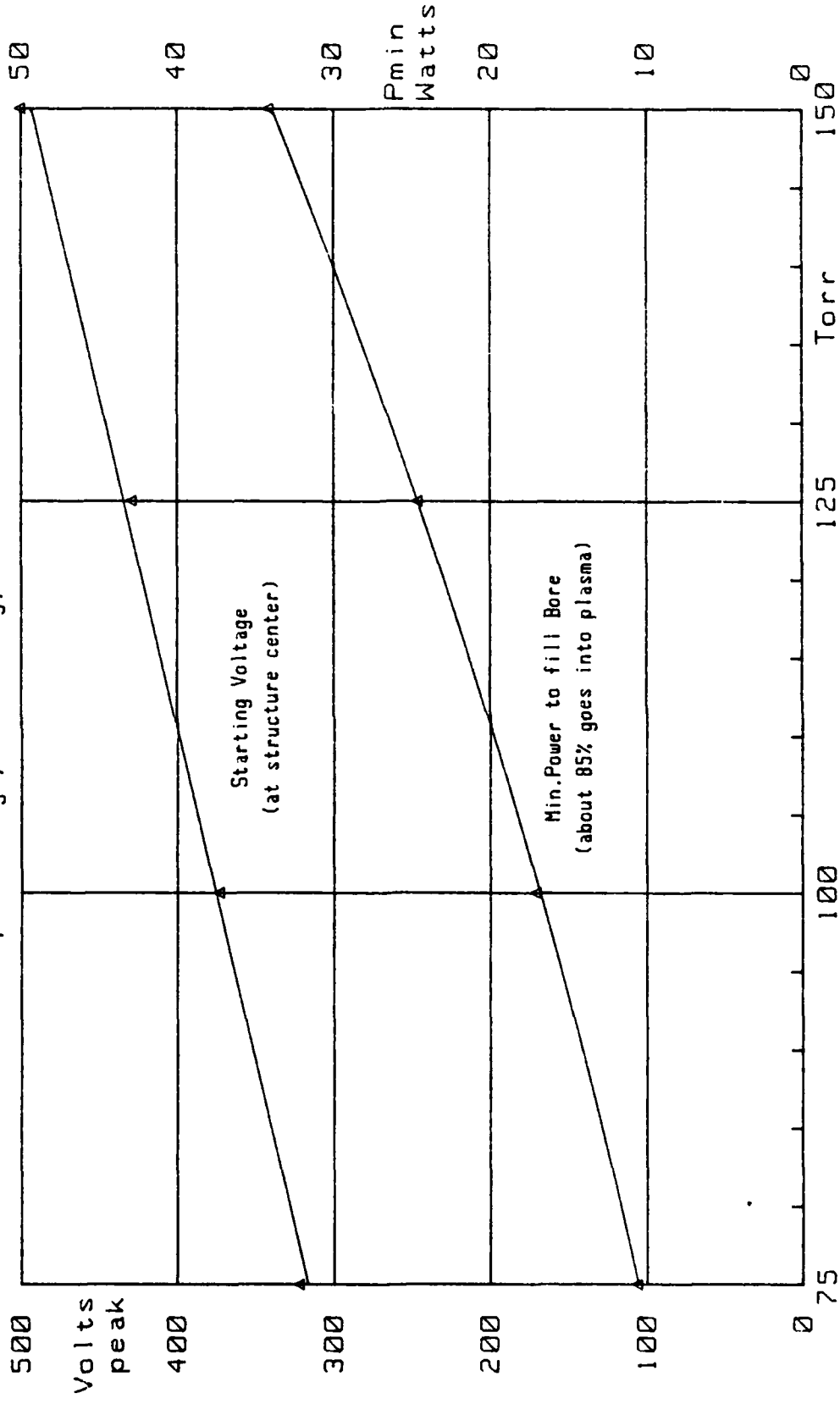

Fig. 16, STARTING VOLTAGE AND Pmin vs PRESSURE

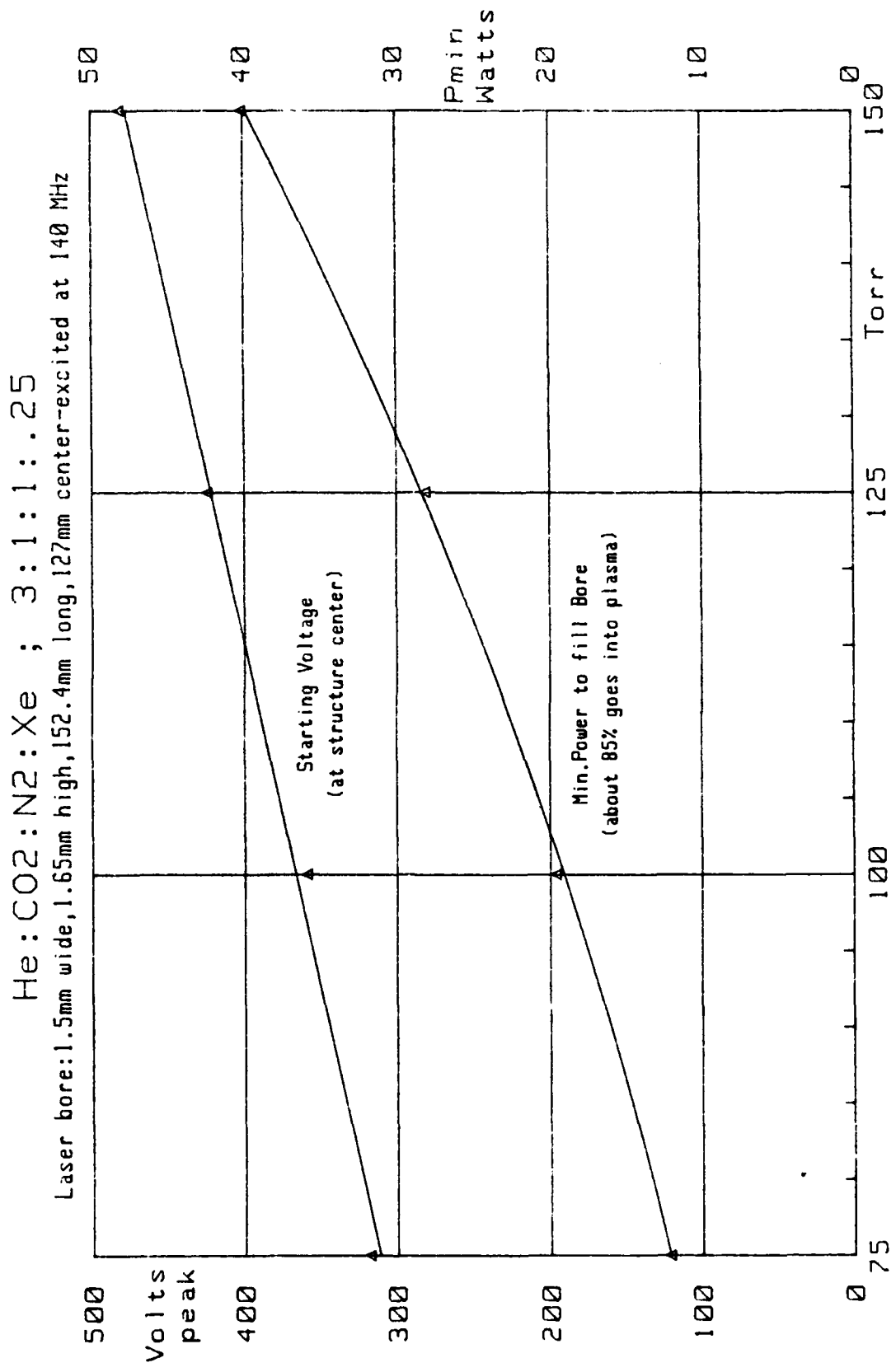

Fig. 17, STARTING VOLTAGE AND Pmin vs PRESSURE

He : CO₂ : CO : Xe ; 4 : 1 : 1 : .25

Laser bore: 1.5mm wide, 1.65mm high, 152.4mm long, 127mm center-excited at 140 MHz

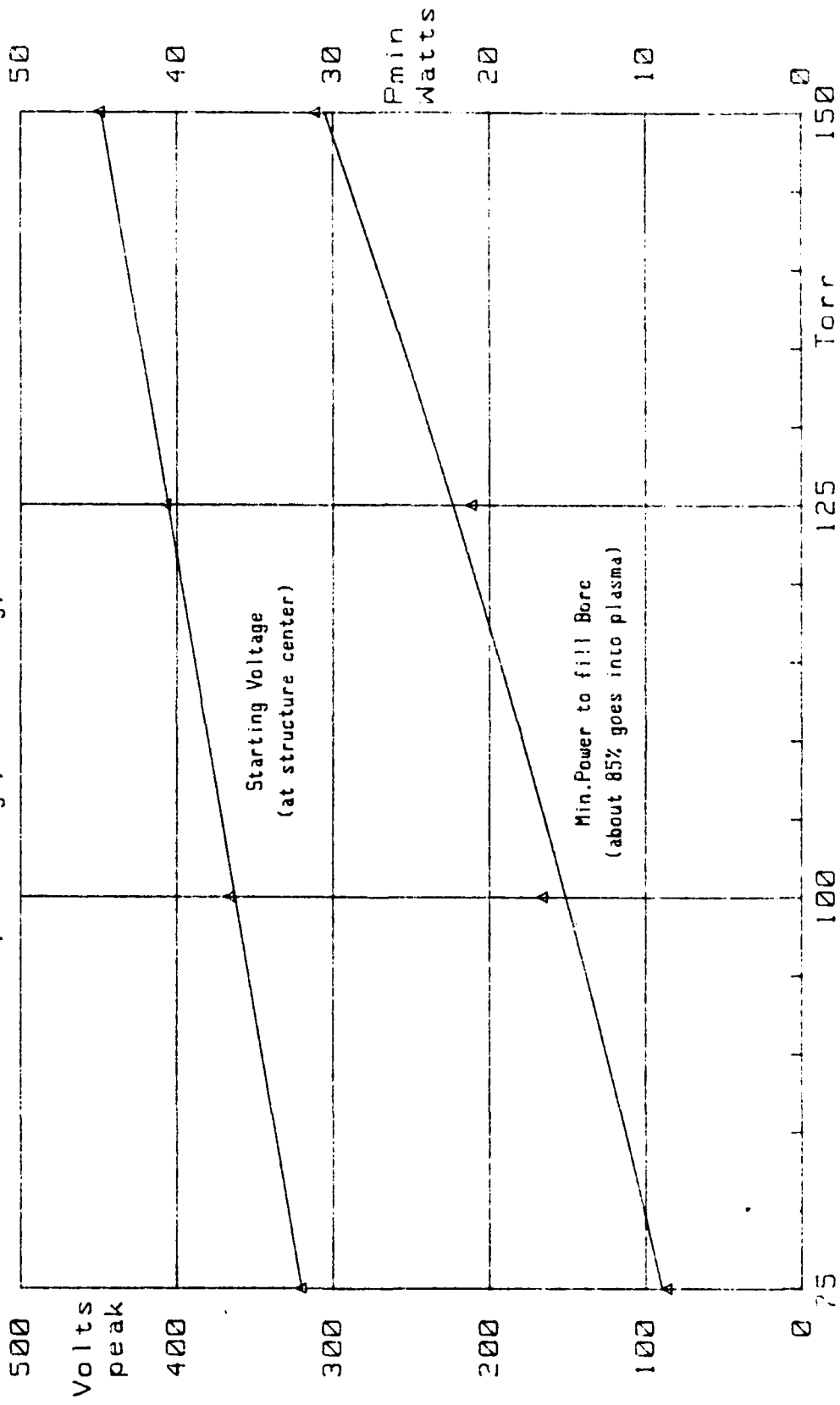

Fig. 18, STARTING VOLTAGE AND Pmin vs PRESSURE

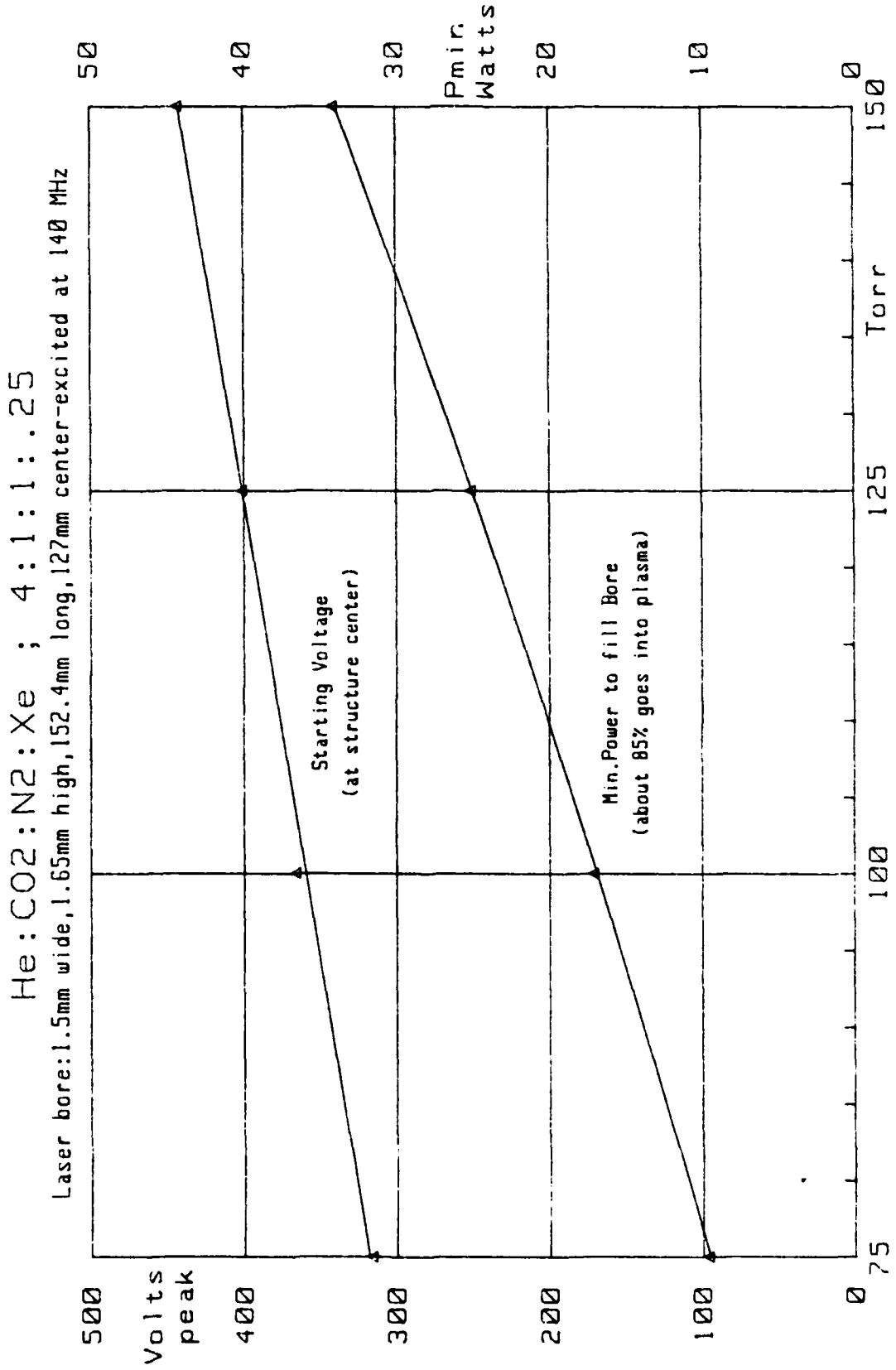

Fig.19, STARTING VOLTAGE AND Pmin vs PRESSURE

He : CO₂ : CO : Xe ; 5 : 1 : 1 : .25

Laser bore: 1.5mm wide, 1.65mm high, 152.4mm long, 127mm center-excited at 140 MHz

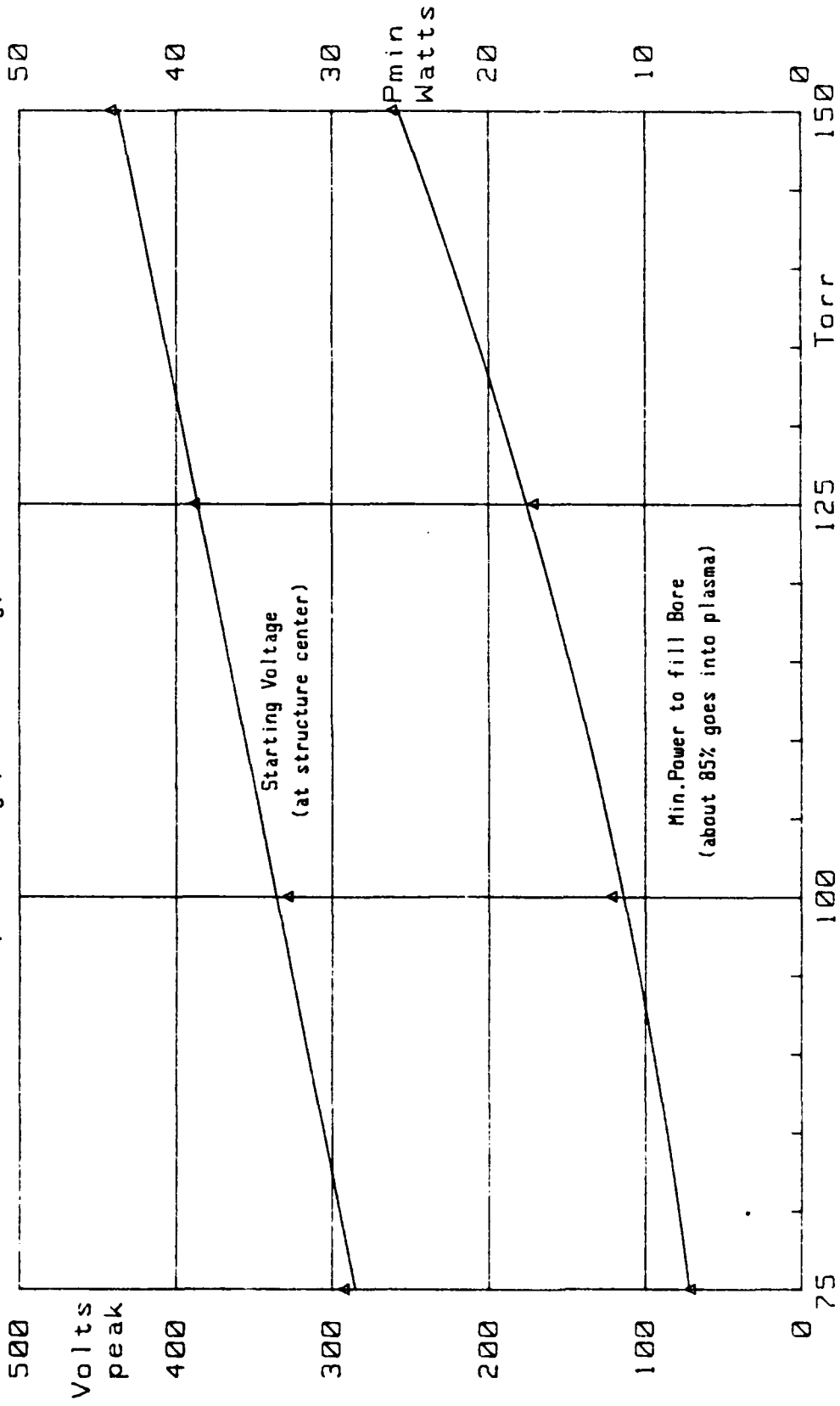

Fig. 20, STARTING VOLTAGE AND Pmin vs PRESSURE

He:CO₂:N₂:Xe ; 5:1:1:.25

Laser bore:1.5mm wide,1.65mm high,152.4mm long,127mm center-excited at 140 MHz

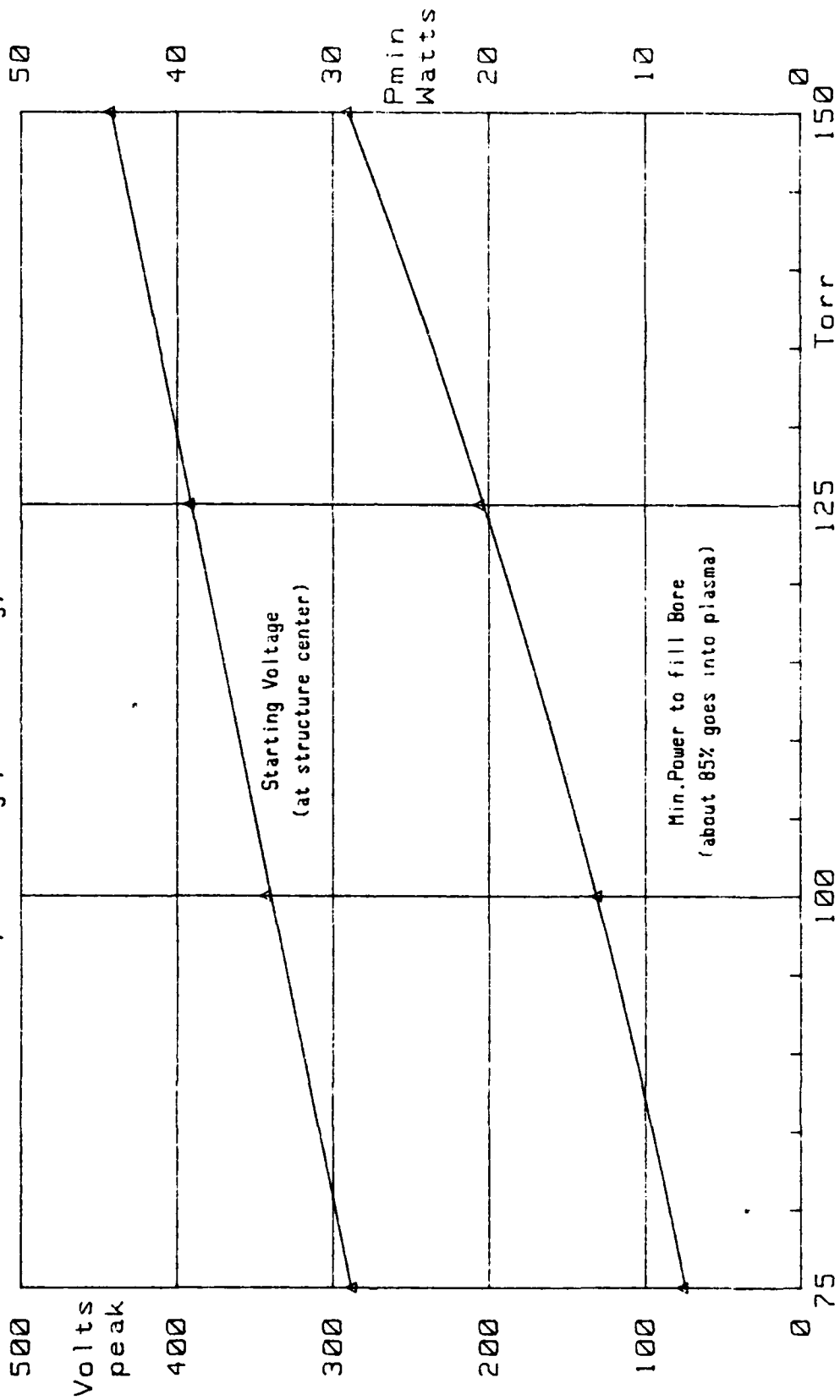

Fig.21, STARTING VOLTAGE AND Pmin vs PRESSURE

TABLE 2

S-PARAMETER MAGNITUDE		S-PARAMETER PHASE					COMPUTED VALUES			
S11	S12	S21	S22	S11	S12	S21	S22	RP	CP	Eff
-1.07	-9.00	-9.00	-0.65	142.5	169.7	169.7	17.9	1188.5	11.11	90.33
-1.17	-9.00	-9.00	-0.65	142.5	169.7	169.7	17.9	1162.3	11.11	90.42
-1.07	-9.10	-9.00	-0.65	142.5	169.7	169.7	17.9	1215.8	11.12	50.22
-1.07	-9.10	-9.10	-0.65	142.5	169.7	169.7	17.9	1244.0	11.12	88.03
-1.07	-9.00	-9.10	-0.65	142.5	169.7	169.7	17.9	1215.8	11.12	88.17
-1.07	-9.00	-9.00	-0.75	142.5	169.7	169.7	17.9	1392.9	11.12	76.28
-1.07	-9.00	-9.00	-0.65	141.5	169.7	169.7	17.9	1186.9	11.15	90.35
-1.07	-9.00	-9.00	-0.65	142.5	168.7	169.7	17.9	1190.8	11.08	90.25
-1.07	-9.00	-9.00	-0.65	142.5	168.7	168.7	17.9	1193.7	11.05	90.13
-1.07	-9.00	-9.00	-0.65	142.5	169.7	168.7	17.9	1190.8	11.08	90.25
-1.07	-9.00	-9.00	-0.65	142.5	169.7	169.7	16.9	1197.0	10.90	90.35

S-PARAMETER VARIATION EFFECTS



70 MHz Transmitter: Output spectrum
10db per div.

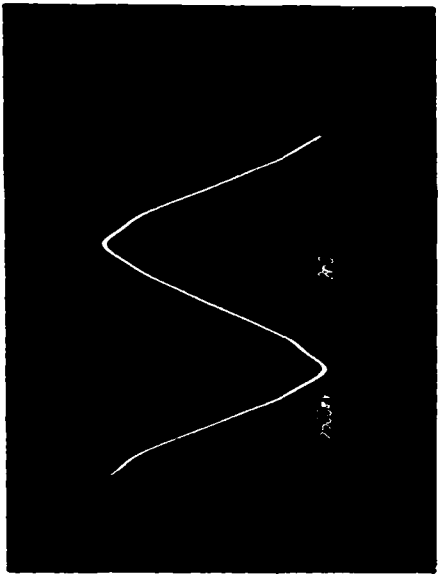

Discharge: Current waveform

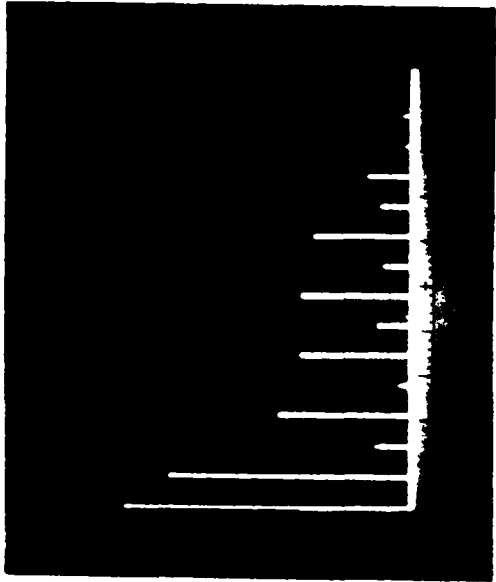

Discharge: Current Spectrum
10db per div.

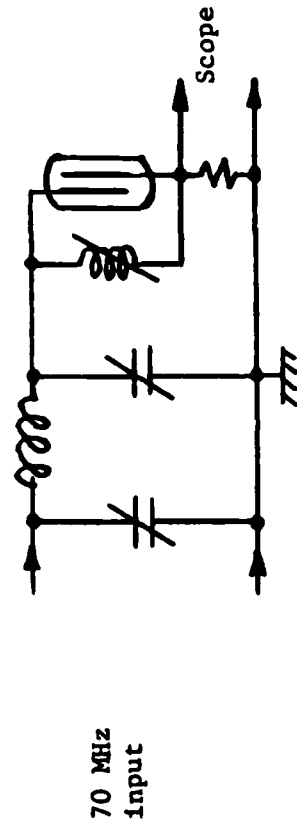

Figure 22 DISCHARGE CURRENT WAVEFORM

END

FILMED

1-86

DTIC