

RD-A168 958

PROCEEDINGS OF CABIN SAFETY CONFERENCE AND WORKSHOP  
HELD ON DECEMBER 11-14 1984(U) FLIGHT SAFETY FOUNDATION  
INC ARLINGTON VA AUG 85 DOT/FAR/ASF-100-85/81

1/3

UNCLASSIFIED

F/G 1/2

NL

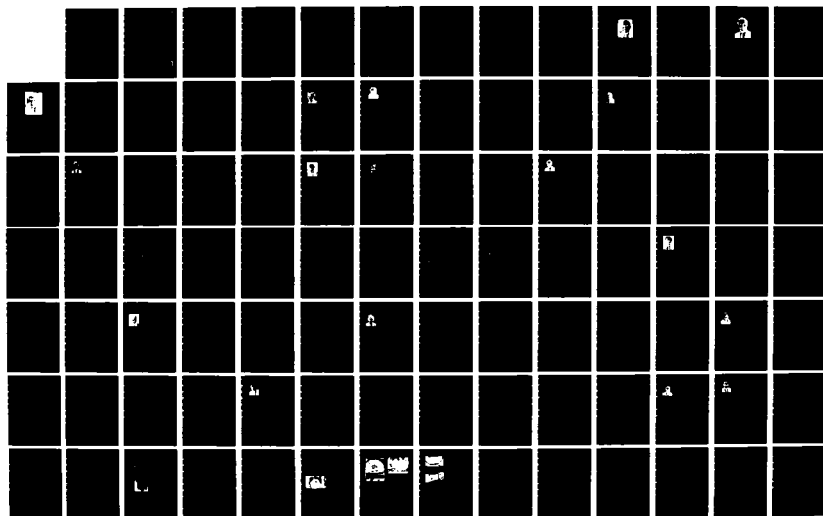

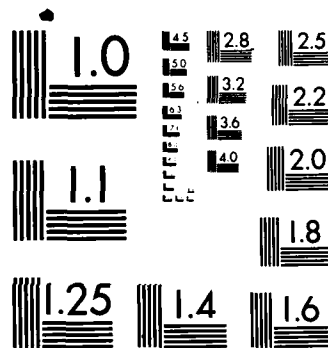

MICROCOPY RESOLUTION TEST CHART  
NATIONAL BUREAU OF STANDARDS-1963-A

12

DOT/FAA/ASF100-85/01  
DOT-TSC-FAA-85-6

Office of Aviation Safety  
Washington DC 20591

# Proceedings of Cabin Safety Conference and Workshop

December 11-14, 1985

AD-A160 950

Flight Safety Foundation, Inc.  
5510 Columbia Pike  
Arlington VA 22204

DTIC FILE COPY

August 1985  
Final Report

This document is available to the public  
through the National Technical Information  
Service, Springfield, Virginia 22161.

DTIC  
ELECTE  
NOV 04 1985  
S E D



U.S. Department of Transportation  
Federal Aviation Administration

85 11 04 088

**NOTICE**

This document is disseminated under the sponsorship of the Department of Transportation in the interest of information exchange. The United States Government assumes no liability for its contents or use thereof.

**NOTICE**

The United States Government does not endorse products or manufacturers. Trade or manufacturers' names appear herein solely because they are considered essential to the object of this report.

**ERRATA SHEET**

An error was made on the date of the Workshop on the front cover of this report. The date should read Dec.11-14, 1984, not 1985 as stated. Please make note of this correction.

All Copies

1. Report No. DOT/FAA/ASFL00-85/01		2. Government Accession No. <b>AD-A160950</b>		3. Recipient's Catalog No.	
4. Title and Subtitle PROCEEDINGS OF CABIN SAFETY CONFERENCE & WORKSHOP DECEMBER 11-14, 1984		5. Report Date August 1985		6. Performing Organization Code TSC/DTS-67	
		7. Author(s)		8. Performing Organization Report No. DOT-TSC-FAA-85-6	
9. Performing Organization Name and Address Flight Safety Foundation, Inc. 5510 Columbia Pike Arlington, VA 22204		10. Work Unit No. (TRAIS) FA590/R5259		11. Contract or Grant No.	
		12. Sponsoring Agency Name and Address U.S. Department of Transportation Federal Aviation Administration Office of Aviation Safety Washington, DC 20591		13. Type of Report and Period Covered Final Report	
				14. Sponsoring Agency Code ASF-1	
15. Supplementary Notes					
16. Abstract  <p>These proceedings contain formal conference presentations as well as summaries of informal workshop discussions on how to further improve aircraft cabin occupant safety. The overall objective of the conference is increased communication between various segments of the aviation community in the area of aircraft safety. Also included are the FSF's analysis and future recommendations for occupant safety.</p>					
17. Key Words  Occupant Safety, Analysis, Aircraft Cabin Safety			18. Distribution Statement  DOCUMENT IS AVAILABLE TO THE PUBLIC THROUGH THE NATIONAL TECHNICAL INFORMATION SERVICE, SPRINGFIELD, VIRGINIA 22161		
19. Security Classif. (of this report)  Unclassified		20. Security Classif. (of this page)  Unclassified		21. No. of Pages  224	22. Price

# METRIC CONVERSION FACTORS

Approximate Conversions to Metric Measures		Approximate Conversions from Metric Measures		
Symbol	When You Know	Multiply by	To Find	Symbol
<b>LENGTH</b>				
in	inches	2.5	centimeters	mm
ft	feet	30	centimeters	cm
yd	yards	0.9	meters	m
mi	miles	1.6	kilometers	km
<b>AREA</b>				
sq in	square inches	6.5	square centimeters	cm <sup>2</sup>
sq ft	square feet	0.09	square meters	m <sup>2</sup>
sq yd	square yards	0.8	square meters	m <sup>2</sup>
sq mi	square miles	2.6	square kilometers	km <sup>2</sup>
	acres	0.4	hectares	ha
<b>MASS (weight)</b>				
oz	ounces	28	grams	g
lb	pounds	0.45	kilograms	kg
	short tons (2000 lb)	0.9	tonnes	t
<b>VOLUME</b>				
sp	teaspoons	5	milliliters	ml
Tbsp	tablespoons	15	milliliters	ml
fl oz	fluid ounces	30	milliliters	ml
c	cups	0.24	liters	l
pt	pints	0.47	liters	l
qt	quarts	0.95	liters	l
gal	gallons	3.8	liters	l
cu ft	cubic feet	0.03	cubic meters	m <sup>3</sup>
cu yd	cubic yards	0.76	cubic meters	m <sup>3</sup>
<b>TEMPERATURE (exact)</b>				
°F	Fahrenheit temperature	5/9 (after subtracting 32)	Celsius temperature	°C

Approximate Conversions from Metric Measures			
When You Know	Multiply by	To Find	Symbol
<b>LENGTH</b>			
millimeters	0.04	inches	in
centimeters	0.4	inches	in
meters	3.3	feet	ft
kilometers	1.1	yards	yd
	0.6	miles	mi
<b>AREA</b>			
square centimeters	0.16	square inches	in <sup>2</sup>
square meters	1.2	square yards	yd <sup>2</sup>
square kilometers	0.4	square miles	mi <sup>2</sup>
hectares (10,000 m <sup>2</sup> )	2.5	acres	
<b>MASS (weight)</b>			
grams	0.035	ounces	oz
kilograms	2.2	pounds	lb
tonnes (1000 kg)	1.1	short tons	
<b>VOLUME</b>			
milliliters	0.03	fluid ounces	fl oz
liters	2.1	pints	pt
	1.06	quarts	qt
	0.26	gallons	gal
cubic meters	36	cubic feet	ft <sup>3</sup>
	1.3	cubic yards	yd <sup>3</sup>
<b>TEMPERATURE (exact)</b>			
Celsius temperature	9/5 (then add 32)	Fahrenheit temperature	°F

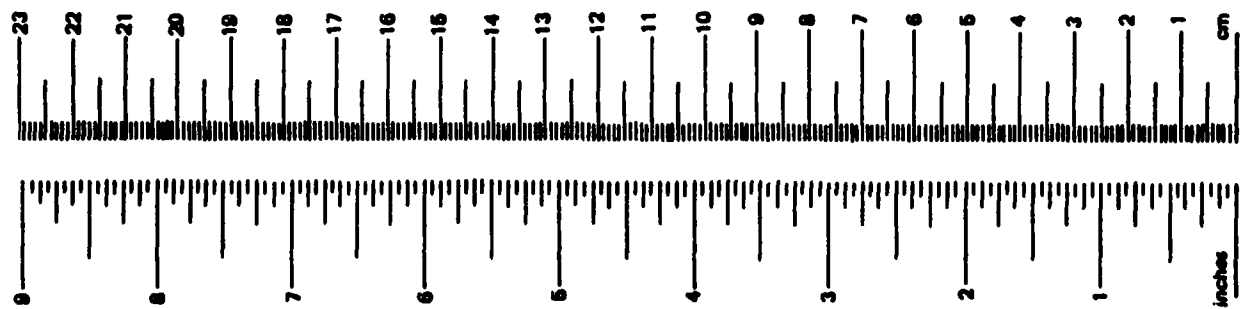

1 in. = 2.54 cm (exactly). For other exact conversions and more detail tables see NBS Mon. Publ. 285, Units of Weight and Measures. Price \$2.25. SD Cutting No. C13 16 285.

# TABLE OF CONTENTS

Preface ..... 1

## OPENING SESSION

Introduction by Conference Chairman: John H. Enders; President, FSF ..... 3  
Welcome to Attendees: The Honorable Donald D. Engen; Administrator, FAA ..... 5  
Keynote Address: Congressman Norman Y. Mineta ..... 7

## Session I: OVERVIEW OF AIRCRAFT OCCUPANT SAFETY PROBLEMS

Moderator: Roger L. Winblade; Assistant Director for Aeronautics, NASA

Statement by the Honorable James E. Burnett; Chairman,  
U.S. National Transportation Safety Board ..... 13  
"An Overview of Aircraft Occupant Safety" H.R.F. Duffell; Head,  
Mechanical & Fluid Systems Group, U.K. Civil Aviation Authority ..... 17  
"Some Thoughts on Cabin Safety" Gerry Marsters, Ph.D.;  
Director of Airworthiness, Transport Canada ..... 22

## SESSION II: CABIN SAFETY INITIATIVES

Moderator: Mack Eastburn; Senior Director - Safety, American Airlines

"Controlled Impact Demonstration: Preliminary Results"  
John E. Reed; CID Program Manager, FAA Technical Center ..... 27  
"Status of FAA Cabin Safety Efforts" Thomas E. McSweeney;  
Manager, Aircraft Engineering Division, Office of Airworthiness, FAA ..... 30  
"USC's Cabin Safety Seminars" Richard K. Brown, Ph.D.;  
Institute of Safety and Systems Management, U.S.C. .... 46  
"Inter-Airline Training Conference" Denise J. Noe;  
Manager, Procedures and Line Training, Eastern Airlines ..... 51

## SESSION III: INFLIGHT OCCUPANT PROTECTION

Moderator: Peterlyn Thomas; Safety Co-ordinator of Flight Attendants, Ansett Airlines of Australia

"Turbulence" Nora Marshall; Transportation Safety Specialist,  
Cabin Safety, NTSB ..... 55  
"Protective Breathing" Arnold Higgins, Ph.D.; Supervisor,  
Survival Research Unit, Civil Aeromedical Institute, FAA ..... 61  
"Inflight Fire" James Brenneman; Fire Protection Engineer,  
United Air Lines ..... 67

## SESSION IV: CRASH AND FIRE PROTECTION

Moderator: Doug Clifford; Chief Engineer, Airworthiness & Product Assurance,  
Boeing Commercial Airplane Company

"Airframe Structural Integrity, Design Criteria" Warren A. Stauffer;  
Director, Engineering-Technology, Lockheed California Co. .... 75



“Occupant Restraint and Human Tolerance in Crash Environment” Richard F. Chandler; Supervisor, Protection and Survival Laboratory, Civil Aeromedical Institute, FAA .....	92
“Post-Crash Fire” Constantine Sarkos; Program Manager, Aircraft Cabin Fire Safety, FAA Technical Center .....	101

**SESSION V: EVACUATION AND SURVIVAL**

Moderator: Hector Barrera; Manager, Flight Attendant Training and Procedures Department, Frontier Airlines	
“Configurational Factors” Paul G. Rasmussen; Evacuation Research Unit, Civil Aeromedical Institute, FAA .....	118
“Procedural Factors” Capt. Roger Brooks; Chairman, ALPA Accident Survival Committee .....	123
“Environmental Factors” Charles R. Crane, Ph.D.; Supervisor, Aviation Toxicology Laboratory, Civil Aeromedical Institute, FAA .....	127
“Water Survival” Gary C. Leegate; Vice President, DME Corp. ....	133
“Biobehavioral Factors” Daniel A. Johnson, Ph.D.; President, Interaction Research Corp. ....	143

**SESSION VI: ECONOMICS AND REGULATORY CONSIDERATIONS**

“Economics of Safety” Thomas D. Hopkins, Ph.D.; Associate Professor, University of Maryland .....	151
“Rulemaking Process” Fred Emory; President, Fred Emory Associates .....	158

**LUNCHEON ADDRESS**

Edwin I. Colodny; President, USAIR .....	164
--	-----

**SUMMARY OF WORKSHOP PROCEEDINGS**

“Inflight Occupant Protection Workshop” .....	167
“Crash and Fire Protection Workshop” .....	172
“Evacuation and Survival Workshop” .....	176

**COMBINED ANALYSIS OF WORKSHOP DISCUSSIONS** .....

Comments and Recommendations .....	181
	199

**REGISTERED ATTENDEES** .....

	201
--	-----

The nearly 370 participants from 18 countries attending the Flight Safety Foundation's Conference and Workshop on Aircraft Cabin Safety were high in their praise of the quality and usefulness of the technical presentations and the workshop sessions.

Sponsored by the FAA, the three-day FSF meeting provided representatives from airline operations and management, manufacturers, suppliers, governments, and other private sector organizations and individuals with both formal and informal opportunities to exchange information and discuss views on how to further improve occupant safety.

This Proceedings contains not only the formal Conference presentations, but also summarizes the essence of the workshop discussions and provides an overall FSF analysis of aircraft cabin safety with recommendations.

The Flight Safety Foundation, on behalf of its worldwide membership, is deeply grateful to FAA for its sponsorship and to all those who contributed their time and efforts in making this event an outstanding success.

<b>Accession For</b>	
NTIS GRA&I	<input checked="" type="checkbox"/>
DTIC TAB	<input type="checkbox"/>
Unannounced	<input type="checkbox"/>
Justification	
By _____	
Distribution/	
Avail	Unclas
Date _____	
A-1	

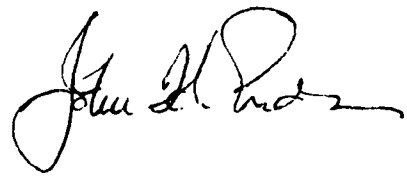

JOHN H. ENDERS  
President  
Flight Safety Foundation, Inc.





**John H. Enders**  
**President, Flight Safety Foundation, Inc.**

## OPENING REMARKS

John H. Enders

On behalf of the Flight Safety Foundation, welcome to this Conference and Workshop on Aircraft Cabin Safety. I am pleased to report that we have approximately 370 registrants from 18 countries in attendance!

The convening of this conference and workshop comes at an appropriate time. Contrary to some assertions, there has been a steady flow of research and design improvements dating back to the NACA transport crash tests of the late 1940's. The objectives have remained constant over the years since then. Prevent the accident in the first place, but if an accident occurs, prevent or minimize the loss of life and property. This gives us the blueprint with which to proceed in pursuing these objectives. The avenues available to reduce the severity of accidents are clear, but limited: Occupant protection from deceleration, structural failure and fire with its effects.

Research and test work over the past 30 years has yielded knowledge about human acceleration and thermal tolerances, new structural materials and design techniques, improvements in fire-resistant and lower-toxicity materials, human factors and behavior in emergencies, disaster training and so on. Converting this knowledge to practice becomes difficult in most cases. Compromises and trade-offs frustrate engineer and crew member alike. Government and industry efforts during the past decade have made phenomenal advances in safety, aided in great part by the recent availability of computerized analysis that can handle complex physical, thermal and statistical parameters that was impossible just a few short years ago.

In 1979, the Special Aviation Fire and Explosion Reduction (SAFER) Advisory Committee was formed by FAA to consider what improvements in aircraft fire safety were feasible. A series of recommendations were made, many of which industry followed, while government began rule-making to require some of these recommendations.

Most recently, FAA and NASA conducted a free-flight transport aircraft crash test at Edwards AFB. The test aircraft incorporated many of the ideas and designs that were developed from the earlier research. Most of the experiments worked though it is too early to know how well they worked or what were the reasons for unexpected performance of other experiments.

Because of all of these efforts, the Flight Safety Foundation is pleased to convene this FAA-sponsored Conference and Workshop in Aircraft Cabin Safety. In so doing, we bring together an international group of individuals representative of management, flight and cabin crew, maintenance, researchers, government regulators, accident investigation specialists, designers, manufacturers, suppliers and other safety specialists. We will hear status reports in several safety areas and then reconvene in workshops to provide opportunities for individual input and group discussion. The overall objective is to foster better communications on safety matters between the different segments of the aviation community with a view toward further overall improvement of aircraft cabin safety.

I wish you all a good conference and workshop experience, hoping that each of you will return to your home base with new ideas and new contacts for safety improvement.



**Donald D. Engen**  
**Administrator, Federal Aviation Administration**

## WELCOME TO ATTENDEES

### Donald D. Engen

It is my pleasure to welcome you here today to help us chart a course for taming a still not solved aviation safety challenge — Cabin Safety. We have made great strides over the years in improving airframes, engines, and systems, to the point where we seem to be fine tuning for improvement.

But that is not the case with cabin safety. We still have a long way to go and the discussions that will be held here over the next three days will be invaluable to the FAA as the agency pushes ahead with what it sees as one of its most pressing priorities — maximizing the chances of a passenger being able to walk or swim away from a less than catastrophic accident.

Not the least problem is communicating with the passengers. How do you get across what to do when the lights go out, there is no power and panic creeps into the minds of those who are not well versed in aviation?

We have just passed a major milestone in crashworthiness — cabin safety testing, the recent controlled impact demonstration. While the anti-misting kerosene did not perform exactly as anticipated, we did get a lot of data that will be invaluable in helping to design survivability into aircraft for the future. We got good film from eight cameras mounted in the cabin of the aircraft. Telemetry data was good — lasting up to 10 minutes after the impact.

This data will tell us for the first time exactly what happens to the airframe, the seats, and the people on board on an airplane, in an impact such as this. The pictures are graphic. The data is real-time, real-life and not the theoretical data our aircraft designers have had to work with in the past. The CID was successful.

All this will go into the data bank that will be the heart of our crash dynamics program. This is an engineering development program to collect and, where necessary, interpolate and extrapolate the technical data needed to design aircraft that will be as impact-survivable as possible. Included will be the impact characteristics of existing aircraft, development of analytical modeling techniques, and the assessment of human injury criteria. Finally, and this is the bottom line, the analysis and correlation of this data will allow the U.S. to develop updated design standards that will insure the greatest possible level of survivability.

Meanwhile, we have taken a number of steps to reduce the post-crash fire problem and several more are in the works. Other FAA speakers here will go into the details of those programs.

Let me simply say that we are fully and firmly committed to the goal of measurably increasing cabin safety and giving passengers the greatest possible chance of surviving in an impact-survivable accident. This is our number one priority and we greatly welcome the thoughtful input that this seminar will provide. This seminar is not designed to be adversarial, but, I hope that each person will speak his or her mind. We need that. I'm sure that the person that I am about to introduce will do just that. An aviation legislator, a friend, a counselor, a challenger, a helper and one who has me on the hook to meet some key safety milestones — Congressman Norm Mineta.



**Norman Y. Mineta**

**Chairman, Subcommittee on Aviation,  
Public Works and Transportation Committee**

## STATEMENT BY CONGRESSMAN NORMAN Y. MINETA

I want to begin this morning by commending the Flight Safety Foundation for organizing and conducting this Cabin Safety Workshop and FAA for sponsoring it. It was not so many years ago that it was difficult to get FAA or much of the aviation industry to accept the idea that cabin safety was something that needed further improvement. It may be appropriate to begin this conference by asking ourselves why cabin safety came to be something so widely acknowledged to need improvement, something that is now a subject of much of FAA's regulatory agenda, and something that is sufficiently important that we hold conferences like this one.

It is no secret that much of the impetus for cabin safety improvements came from some of us in Congress, beginning with our hearings in the 1970's. I was asked at that time what problem it was that we were trying to solve. After all, aviation was already so much safer than other transportation modes, weren't we barking up the wrong tree? In short, how safe is safe enough in aviation?

Everybody is for *safe* transportation, but what does that really mean? Nothing in life is totally safe. There is *some* degree of risk associated with everything. When we say we want *safe* transportation, what level of risk is acceptable to us? I remember a few years ago that Langhorne Bond testified to the Aviation Subcommittee that "... traveling on a scheduled airliner is safer than almost anything, even than staying in bed."

This prompted a question as to whether there was some particular peril in bed that Langhorne had in mind.

Looking honestly at our society, I think we have to say that the answer to the question — how safe is safe enough — varies widely by mode of transportation. Looking at the past five years, there have been an average of 150 fatalities per year in air carrier accidents. In the same period there have been an average of nearly 50,000 highway deaths per year.

Comparing the two modes of transportation of a per passenger mile basis, you are roughly *130 times safer per mile* on an air carrier than you are on this nation's highways. Those of us who have been around safety statistics long enough eventually get to the point where we are more nervous driving to the airport, and then once we get there and take our seat on the airplane we relax and feel more secure. But most Americans have an exactly opposite reaction: they jump in the family car with little or no safety concern, but their anxiety level goes up when they get aboard an airplane. As contrary to the facts as those feelings may be, they are what determines in our society how-safe-is-safe for each mode of transportation.

I would suggest to you that that 150 fatalities per year for air carriers and 50,000 fatalities per year for highways is an indication of what our society considers *acceptable relative levels of safety for each of these modes*. Not *acceptable* in the sense of desirable: not *acceptable* in the sense that people don't mind these fatalities and don't wish they were lower; but *acceptable* in the sense that at those levels *most* Americans are willing to jump in the family car or to board an aircraft to get where they want to go. They do in fact *accept* that level of risk.

Our society clearly imposes a much higher safety standard on aviation than it does on highways; in fact, the discrepancy between the two standards is clearly beyond the realm of the rational. How-safe-is-safe is ultimately a question of social values, better approached by social scientists or political philosophers than by engineers, who are entirely too rational. No rational risk analysis or cost-benefit analysis would conclude that the next increment of safety improvement needed in this country is in aviation.

Yet the fact is that aviation *has* to meet a much higher safety standard. To argue the irrationality of the discrepancy in safety standards, to argue that any aviation safety proposal would save only a very few lives, to argue that there are other areas where less cost and effort would save far more lives: all that is true but irrelevant.

Aviation *has* to meet our society's higher safety standard for aviation. Arguing against that standard is like arguing against gravity or against the sun rising in the east. If aviation is to thrive and grow in our society it has to meet our society's safety standards, whatever those standards might be.



The hard fact is that if air travel were only 10 times as safe as highway travel, almost nobody would be willing to fly. The irony is that they would drive instead.

Unlike our nation's highways, air travel is so safe that there are no relatively low cost/low effort solutions laying about which would save large numbers of lives. We are down to straining to achieve relatively small increments of safety improvements. On the highways, you have the fact that virtually all cars are equipped with seat belts, yet only about 14% of us bother to buckle up. It is estimated that roughly 15,000 American lives could be saved *annually* if everybody would just buckle the seat belts which sit within their easy reach.

In aviation, on the other hand, when you consider that there are only about 150 air carrier fatalities per year, and that in most of those fatal accidents the aircraft or its mechanical systems were no part of the cause of the accident, it becomes clear that there is nothing that can be done in the area of aircraft design, materials, or performance that could save more than a few lives per year. That is not to say that nothing should be done. On the contrary, what it does mean is that the argument that a given safety proposal should *not* be pursued because it would save only a few lives a year is an argument for no improvement at all in aircraft safety, and that kind of stand-pat approach is clearly not going to meet this society's sense of what should be happening in aviation safety.

Once you accept the superlative safety record of aviation, the much higher safety standard which aviation must meet in our society as compared to other modes, and the fact that the traveling public has long experienced and has come to expect continuous improvements in aviation safety, then the increased importance being placed on cabin safety is entirely logical. Cabin safety became one of the necessary next steps in the march of ever-improving aviation safety precisely because aviation safety had previously been raised to such a high level.

In aviation we have a safety system which has traditionally been oriented toward crash prevention, an objective no one would quarrel with. But we have made so much progress on that front that now, as we search for those increasingly hard-to-find extra lives that could be saved, we need to look more in the area of crash survivability and cabin safety.

The fire safety threat posed by the urethane cushions in aircraft, the very low crash resistance capability of aircraft seats and their floor attachments, problems related to rapid egress in a post-crash setting, smoke detectors in closed-off areas such as lavatories: these are all areas where safety remedies *are* available even though the absolute number of lives saved would, of course, be relatively low.

What we find is that, as is so often the case, our greatest strength has also produced a corresponding weakness: our remarkable record of success in aviation crash *prevention* has tended over the years to leave us with little improvement in crash *survivability*. The irony is that the automobile, where the crash prevention effort has been such a failure, now sometimes surpasses the airplane in crash survivability. In seat and restraining system design, for example, the airplane is basically designed with inflight turbulence and normal service forces in mind and *not* with the survivable crash in mind. The automobile seat and restraints must meet a 20 g's forward standard, while the airplane seat must meet only 9 g's forward. What we find in aviation accident reports is that in what should be survivable impacts, well within the tolerance limits of the properly restrained human body, seats are *breaking loose from the floor*, piling victims on top of each other, and creating an insurmountable barrier through which survivors find it difficult or impossible to evacuate.

That, to me, is the kind of weak link that continues to exist in the chain of aviation safety, and, like so many of those remaining weak links, it is a crash survivability or cabin safety issue. In aviation safety we ought to be able at the very least to meet the tragically low safety standards of the automobile, and in seats and restraints we have failed even that minimal test. There is no reason why we should not be able to have a seat and restraint standard which more closely approximates the impact tolerance of the human body.

That is one example of the kind of improvement that remains to be made in aviation safety. In all cases the absolute number of additional lives saved, because of the excellent safety record already achieved, is bound to be small. But these clearly are safety improvements which could be made and lives which could be saved, and we need to exert every effort to achieve these improvements. Some of these issues pose considerable technical complexities, such as improved flammability, smoke, and toxicity standards for cabin materials. Others are relatively straight forward, such as smoke detectors for lavatories. But there *are* safety

improvements which can and should be made, and the traveling public in general and the Congress in particular will continue to insist on those improvements.

After years of Congressional hearings and pressure on FAA to get on with rulemaking in the cabin safety area, there clearly was growing Congressional impatience at FAA's difficulty and/or reluctance to issue new cabin safety regulations. We had a number of bills proposed which would have required FAA to issue certain regulations by specified dates, no matter what.

We adopted, however, a different approach. During our hearings this past Summer, FAA had come forward with a schedule of regulatory actions they said they planned to take in the coming months. It even included some issues, such as improved seat strength standards, which I believe are an important part of cabin safety but which were not included in any legislation pending before the Subcommittee. We decided to hold the FAA to that schedule, to require them to file monthly reports with the Subcommittee on how their actual regulatory actions stacked up against their promised regulatory schedule (and we keep those reports as a matter of public record, for anybody's use). We certainly retain the alternative that if the FAA falls significantly behind schedule, we can go ahead with legislation.

What we have seen in the past few months is an FAA which is moving ahead with regulations in the cabin safety area.

In the period just since our hearings this summer, FAA has issued final rules requiring fire blocking layers on all seat cushions, floor level emergency lighting, and standardized child restraints. Furthermore, the FAA at this point appears to be on schedule to issue final rules requiring smoke detectors in galleys and lavatories, automatic fire extinguishers in lavatory trash receptacles, and more and better fire extinguishers throughout the cabin, and to make regulatory proposals<sup>1</sup> requiring portable protective breathing devices for flight attendants, improved fire training for flight attendants, new standards of fire safety for cabin materials generally, and expanded on-board medical kits — all this by the end of this month.

So there is no question that FAA is now moving into regulatory actions on cabin safety, and that is something we in Congress welcome. We hope to see a great deal more FAA regulatory action on cabin safety in the coming months, and if those hopes are not realized you will see again a rising sense of frustration in the Congress.

One of the regulatory actions FAA promised Congress last Summer was a Notice of Proposed Rule-making on AMK by the end of this year. Given the recent Crash-In-The-Desert, questions have been raised about the whole AMK program, and I may as well take this opportunity to register my own comments.

I have been asked whether, given the results, the FAA was unwise to conduct the test at all, and my answer is no. You conduct a test or an experiment to find out the answer, whatever it might be. In an experiment there are no right answers or wrong answers, only real answers and we need to know them. If this particular test produces *no* useful data, then clearly the test was improperly structured. In that case the proper conclusion would be that the test should have been done differently, *not* that it should not have been done at all. But if, as I believe will be the case, this test does produce data on a wide variety of cabin safety issues, then it is useful whatever that data may tell us.

On AMK in particular, I am not aware that there is yet sufficient analysis and understanding of what happened in the crash test so that we can draw clear conclusions at this point, although you will be getting the latest update on that later in this conference. Proper analysis of test results is not necessarily completed in time for the next morning's newspapers. Let's wait until we understand what the test results are telling us before we decide where to go next with AMK.

But one conclusion I will venture at this point, and this is something I had concluded before the Crash-In-The-Desert. Whatever is ultimately determined about AMK, we cannot hold in abeyance other fire safety measures in the cabin in the belief that AMK will someday make all our fire problems go away. In our past work in this field we sometimes encountered the view that the kind of things we were pushing for

---

<sup>1</sup>NPRM's

— improved fire safety standards for cabin materials, fire blocking layers for seat cushions, and so on — were a waste of time because most of the fire damage was from the post-crash fire and the post-crash fire problem would be solved by AMK. My view has been quite the opposite: that whatever success AMK may ultimately have in preventing the misting of jet fuel spilled from a fast-moving post-crash jet, and whatever success it may ultimately have in overcoming various practical problems, there will still be a wide range of fire safety threats in the aircraft cabin: threats from post-crash pool fires, threats from in-flight fires, and threats from fires produced like the one in the desert by scenarios we had not anticipated. Whatever course is ultimately taken on AMK, it is imperative that we move ahead in other areas to improve fire safety in the cabin.

Looking back on the cabin safety issues, I think we *can* at long last see some progress. We have reached a point where the need for improved cabin safety regulation is widely accepted and acknowledged, and we have reached the point where those new regulations are being issued. Both these developments are encouraging, but we still have a long way to go in cabin safety. Aviation fatalities have *not* come to some irreducible plateau. There *are* steps which *can* be taken to further improve safety performance in this industry, and many of those steps are in the cabin safety area.

How safe is safe? For aviation our society basically has a two-part answer:

- (1) Safer than for other modes of transportation, and by a wide margin, and
- (2) Safer with each passing year.

Aviation has grown in part because it has shown an ever-improving safety record. As outstanding as its safety record now is, our society expects that safety record to continue to improve. I think it can improve and will improve. Aviation got where it is today by meeting standards far more demanding than most other segments of our society have to meet. I think aviation will continue to meet those ever higher standards.

Thank you.

**SESSION I**  
**OVERVIEW OF AIRCRAFT OCCUPANT SAFETY PROBLEMS**



**Panel Moderator**  
**Roger L. Winblade**  
**Assistant Director For Aeronautics, NASA**

Roger L. Winblade is Assistant Director for Aeronautics (General Aviation and Transport Aircraft) for the National Aeronautics and Space Administration. He is responsible for the broad range of research and technology development programs that address large transports, commuter aircraft and general aviation.

He has been with NASA since 1960 where he has worked on many projects including the X-15.

He was recalled to active duty in 1968 and served as a fighter pilot in the USAF.

He is the author of numerous technical papers and reports and holds a patent on an energy management system for boost glide vehicles.

He received the NASA exceptional service medal and the AIAA Medal for General Aviation. He has been a civil pilot since 1953 and has a commercial pilots license and a flight instructors rating.

He has been a member of numerous technical committees in AIAA, SAE, IEE, RTCA and the National Academy of Sciences.



**James E. Burnett**  
**Chairman U.S. National Transportation Safety Board**

The Honorable James E. Burnett was elevated to the post of chairman of the National Transportation Safety Board in 1982 — four months after becoming a member of the board.

He has taken a leading role in safety board efforts to reduce the number of transportation accidents involving alcohol abuse.

Chairman Burnett has repeatedly expressed concern over the potential for disaster caused by railroad crews operating trains carrying hazardous materials or passengers while under the influence of alcohol or drugs.

Within NTSB he has emphasized aviation crashworthiness, human performance evaluations in accident investigation and child safety seats.

A native of Clinton, Arkansas, Chairman Burnett was the youngest judge in the state when he was elected municipal judge for Clinton and Van Buren County in 1974. He also served as Juvenile Judge for Van Buren County.

## STATEMENT OF CHAIRMAN JAMES E. BURNETT

Good morning. I want to begin by thanking the Flight Safety Foundation for inviting my participation in this conference and workshop on aircraft cabin safety.

It was, as always, a pleasure to hear from Don Engen, a friend and former colleague on the Safety Board and from Congressman Norman Mineta, a well informed and articulate advocate of aviation safety.

Both men are optimistic about the future of aviation. I share their optimism about what the future holds for passenger safety. But because of that optimism about the future I am reminded on this mid-December day of a child's view of Christmas — why isn't it here yet?

Let me try to illustrate this theme by taking you back in time roughly 30 years. In 1954 the first man-made satellite, Sputnik, was still three years away. Airlines were flying coast to coast, but flights took 10 or more hours. Today, the space shuttle flights are nearly routine and ships of the air like the DC-10 and the Concorde have cut travel times by more than half.

But have we come that far in terms of cabin safety and crashworthiness?

Let's look first at cabin seats. There was more room in 1954, but seat strength remains virtually identical today... Actually, I should say seat weakness is virtually identical today because seats on modern airliners still tear loose under circumstances of even light impact or sudden twisting movements.

And picture the pre-flight briefing for passengers which was first required in 1965. That hasn't changed much in nearly 20 years... One thing that has changed is that most were conducted by a stewardess, while today they are all flight attendants... But the substance remains the same. Today, they hold up a seat belt and an oxygen mask and explain their use. Most point to the emergency exits, while travelers who pretend to be sophisticated bury their noses in the daily newspaper or in-flight magazine.

In short, despite the repeatedly demonstrated need for passengers to be better informed — or better "psyched" — to deal with an emergency, the message and method of delivery remains largely the same.

And speaking of "largely the same," the life vests in today's aircraft are nearly carbon copies of equipment in place since 1946. I was reminded of this as recently as last year. The occasion was a hearing I chaired as part of our investigation concerning the narrowly averted ditching of an Eastern L-1011 off Miami when it lost engine power because of oil leakage due to missing O-rings.

We heard from flight attendants of passenger difficulty in donning life vests, particularly on the part of those who attempted to follow directions to remain seated with their lap belts fastened. These reports renewed Board concern over the effectiveness of current life vest design and the instructions provided to passengers.

The bottom line of these examples is that advances in passenger protection have not kept pace with other advances in aviation technology. It is clear to me that one reason for this lagging posture is that crashworthiness of aircraft... and passenger protection... has simply not received comparable attention.

Another reason, and one that has insidious consequences, has been the widely held belief by the flying public that most airplane accidents are instantly and totally catastrophic. But the board's accident statistics speak otherwise. During the last 10 years there have been 258 U.S. air carrier accidents involving some 22,700 occupants. While over 18 percent of these accidents were fatal accidents, only 9 percent of the occupants were fatally injured.

Nevertheless, this represents almost 2,000 persons, many of whom could have been saved if only the subject of cabin safety had received as much attention as the rest of aviation technology.

I believe the public attention afforded the Air Florida crash, which was theoretically a non-survivable accident, but which produced survivors... and the Air Canada in-flight fire, in which half of the 46 on board survived, may have made small inroads in perceptions about the inevitability of death in an aircraft accident.

We made some progress when public and congressional attention to the Air Canada accident moved the FAA to respond in a generally favorable manner to our recommendations concerning lavatory smoke

detectors, fire extinguishers and standards for cabin materials. FAA action on fire-blocking layers for seat cushions was certainly overdue because the Safety Board and its predecessor agency had been urging cabin material regulations for nearly two decades.

I think I am safe in making the assumption that it is as unsettling to you as it is to me that it apparently takes tragedies of the magnitude of the Air Canada accident to bring about improvement. This phenomenon — a disaster-response mentality rather than a disaster-prevention approach — is one of the more frustrating realities we in the safety business face.

But the problem in letting headlines set the safety agenda is that the spotlight can cast dark shadows that obscure other dangers. For example, the Air Canada accident created a public impression that cabin safety and fire safety are one and the same. We cannot — and I say this with all the emphasis I can muster — we cannot leave the public with the impression that fighting fire and smoke is all there is to saving lives in an accident.

This is not to say we oppose the well-publicized efforts to reduce the threat of post-crash fire through the development of anti-misting fuel; but this should not obscure other problems in need of attention.

That returns me to a discussion of the seats. What often happens in a survivable accident is that seats give way. The result is injury, death or blocked escape routes.

The regulations on seat strength, now more than 30 years old, specify how many "Gs" of forward, downward, and sideways force a seat must be able to withstand. But only static testing is required, and that can be done in one direction at a time. That would be fine if the forces of an actual crash were applied slowly and in one direction at a time. But they aren't. We know that in real life, crash forces react with each other in very complex ways.

What's needed are test methods that replicate true crash conditions; standards based on those tests; and seats that meet those standards.

That's what government accident investigators told the FAA after a Flying Tiger Constellation ditched in the North Atlantic in 1962. More than a third of the 76 passengers and crew were unable to evacuate the sinking craft. Survivors reported the plane did not hit the water with extreme force, but escape was blocked for many by piles of broken seats.

Since then, survivable accidents have included the United Airlines crash at Chicago-Midway Airport in 1972, Air Wisconsin's crash into a rain-soaked field in Valley, Nebraska in 1980, and the Air California B-737 accident at John Wayne airport in Santa Ana in 1981. Another example is the accident involving the ditching in the Caribbean in 1970 of a DC-9 operated by Overseas National Airways. Many people were killed or severely injured in those cases because of seat failures.

Of course, the NTSB is still pressing FAA for improvements in testing and standards of seats. And incidentally, those in the general public are always surprised to learn that airliner seats do not come close to the stress capacity of automobile seats; and cars usually crash at lower speeds.

While I'm thinking about automobiles, let me mention that the Safety Board is convinced that the use of child safety seats has life-saving potential in a plane crash as well as in an automobile accident. In that regard, I have some really good news. The Safety Board had urged the Department of Transportation to coordinate the work of its FAA and the National Highway Traffic Safety Administration and allow NHTSA-approved child safety seats to be used in aircraft cabins.

For too long, the FAA had been insisting on child seats having to meet a separate technical standard that would have made many of the existing car seats ineligible for use on airplanes. The good news is that the FAA has decided that it will accept all federally approved child safety seats for use on aircraft.

But seats are certainly not the only items in an airplane that can cause injury and block escape. There is danger as well from overhead panels, racks, passenger service units and galley equipment. Virtually all interior furnishings can be wrenched loose with surprisingly little force.

Sources of injury are not limited to what's installed. There's also what passengers bring on board.

I am astounded and frightened by what disappears into the overheads — beyond luggage carriers and portable computers, I've heard that has even included bowling balls!

My discomfort over this use of overhead bins is magnified by my knowledge that a Safety Board study found that overhead compartments failed in 78 percent of survivable accidents. When these bins dump their contents on the passengers below, the most frequent injuries are to the head. Even when the blows aren't in themselves serious, they can be enough to stun the person and prevent him or her from reacting quickly in the emergency.

The more items allowed in the cabin, the greater the convenience for the passengers and the less demand on the carrier's baggage handling system. It's no wonder that some airlines seem to welcome additional carry-ons.

I fear that efficiency and convenience may be won at the cost of diminished occupant protection and I hope the FAA will give thorough consideration to the petition by the Association of Flight Attendants seeking a limit on the size of carry-on baggage to be sure it can be properly stowed. One hopeful sign for the future is that, as I understand it, Boeing has announced a new interior design that will increase the cabin storage capacity by seventy-six percent. It is a hopeful sign, of course, only if these storage areas remain secure in survivable accidents.

A basic lesson that we have learned over the years is that any delay — even a few seconds — can have terrible consequences in the crucial moments after a crash. When a passenger does the wrong thing, that person may jeopardize not only his or her own life, but also those of many others.

As I said earlier, the passenger briefings and printed cards in the seat pocket do not inspire passenger attentiveness. The result has been ill-prepared and complacent passengers. There's nothing to be gained from promoting a fear of flying, but it is important for those on board to understand the possible hazards and the correct ways of responding to them.

And by the way, I believe that in addition to the aircraft environment, the consumption of alcohol by passengers may also contribute to their inability to respond quickly and appropriately, and this may also put fellow passengers at risk.

I'd like to tell you a story. This tale is now a legend at the Safety Board. A flight attendant supposedly had become frustrated with the near-total inattention that greeted her pre-flight briefing. So, one day, she intoned in her usual manner: "When the mask drops down in front of you, place it over your navel and continue to breathe normally."..... Not one person looked up; there wasn't so much as an arched eyebrow.

But we live in an age of sophisticated communication techniques. Surely we can combat this nose-in-the-paper attitude. Approaches to the problem might include presentations at the departure gate, on-board films combining safety with a promotional message, or the use of passenger volunteers in the demonstrations. More brainstorming and evaluation is needed.

To that end, the Safety Board has urged the FAA to convene a government industry group to study the problem of passenger education and suggest improvements. The FAA has been partially responsive in that it has indicated it will have a consulting group look at the issue in the general context of cabin safety.

At the same time, the Board's Bureau of Technology is drafting for the Board a proposed study aimed at developing improved techniques for educating passengers and finding ways of putting those techniques into service. I expect the study would take advantage of the expertise of airlines, aircraft manufacturers, passenger organizations, as well as unions and researchers.

The fact of the matter is that there are few public places where people are packed more tightly together than in an airplane. And there are few places where such deadly hazards can materialize so rapidly. The challenge before industry and government is to provide an escape from those hazards.

It will take improved design, stronger regulations and revised company procedures. Home furnishing designs of the 1950s have passed out of fashion. Aircraft interiors of 1950's vintage are also outdated. It is not a case of fashion, however. It is a matter of safety. In some cases it is a matter of life and death.

Thank you.





**H.R.F. Duffell**

**Head, Mechanical & Fluid Systems Group,  
U.K. Civil Aviation Authority**

Mr. Duffell began his career with the Hawker Aircraft Company where he served a five year engineering apprenticeship qualifying in Mechanical and Production Engineering after which he headed their Life Support Systems Design and Development Section. He joined the Civil Aeronautics Authority in 1969 as Design Surveyor in the Life Support Group, becoming the head of that section in 1980. In 1982 he was appointed to his present post as head of the Power Plant, Installations, Mechanical Fluid Systems and Life Systems and Equipment Group.

# CABIN SAFETY

## AN OVERVIEW OF AIRCRAFT OCCUPANT SAFETY

H.R.F. Duffell

### Introduction

Firstly may I take this opportunity to thank you for inviting the CAA to participate at this Conference and Workshop on Cabin Safety.

International cooperation in matters such as these is most important and we, as a member of the European Airworthiness Authorities, are looking forward to taking part in the widely varied topics associated with this subject. A subject in which we have seen significant new requirements activity in the recent past and one in which, no doubt, further requirement activity can be anticipated over the next few years.

Of the many topics that come under the broad heading of Cabin Safety, it is perhaps cabin fire safety that has received the most attention of recent years. It is a subject which has promoted much discussion on both sides of the Atlantic but, so far as cabin furnishing materials are concerned, one in which, until quite recently, research effort has not given any clear guidance on the way in which we should perhaps be proceeding in future — but more of that later.

Another important area deserving of attention, is post impact survival, not only from the point of view of the post crash fire but also in terms of optimising occupant restraint and minimising the hazards arising from loose cabin articles.

Another area in which we should perhaps be directing more attention, is the emergency alighting on water — the ditching. Not the premeditated ditching which, for the large fixed wing aeroplane, occurs very infrequently, but the unpremeditated ditching. Statistically speaking, the unpremeditated ditching has a far higher probability of occurrence and yet, historically, the provisioning of liferafts and lifevests is associated with extended overwater operations. Perhaps the provisioning of quick donning lifevests of a suitable type should be considered for all public transport operations over or near to water. Having looked at the agenda, I note that this and many related topics will be subjects for further consideration by the working groups. It will be interesting to see how discussions develop on this subject.

It is likely that the two main topics for discussion will be; impact survival and fire, both in flight and post crash.

### Occupant Impact Survival

An impact survivable accident has been described as one in which, within the human tolerance, the immediate cabin environment of the occupants remains sensibly intact. Within this rather general definition, there have been a number of accidents where, although the fuselage has remained intact, seat to floor attachments have failed, with incapacitating injuries to the seat occupants. Such injuries may not, in themselves, be major but in the post crash fire scenario such injuries may make the difference between life and death.

For the most part, aircraft seating has, for certification purposes, been qualified against static loading cases, and whilst dynamic loading tests have been periodically undertaken, such testing to date has never formed an essential part of the Certification procedure.

Recent testing in the UK has shown that whilst current large transport category aircraft seat designs are well able to withstand well in excess of 20 'g' in a typical dynamic loading case, floor rail and seat to rail attachments have shown signs of distress and, in some cases, premature failure. Some failures may, in part, have been due to the lack of precise representation of the aircraft floor flexural characteristics in this particular programme of tests. Be that as it may, it indicated the need for further research in this area. The

Controlled Impact Demonstrator (C.I.D.) with its instrumentation of the airframe, seats and anthropomorphic dummies, will hopefully yield many of the answers necessary to improve future seat and seat airframe interface design features.

Whilst it is unwise to anticipate the outcome of such work, it seems probable that this may lead to the use of dynamic test as part of the certification approval of seats but in our view such tests should only supplement and not replace minimum static strength tests presently required.

Another area in which it is hoped that the C.I.D. will yield useful design data is that of the overhead stowage bins for carry-on baggage. There appears to be an ever increasing demand for high capacity stowage bins throughout the passenger cabin. This places an increasing need to be satisfied that the mechanical integrity of the bins and associated door latches is such that they will not fail or open under conditions of fuselage flexure associated with the limiting survivable accident. Regarding burst proof latch design, it seems to us that not enough attention has been paid to this feature in the past and that perhaps the Aerospace Industry could learn a lot from the Automotive (car) Industry.

So far I have talked about injuries in the post crash environment but we should not forget those arising from in-flight turbulence.

To cater for unexpected clear air turbulence, it is recommended that throughout the flight, a passenger, when seated, fastens his or her seat belt. Nevertheless, we permit galley carts, some of which weigh up to 250 lbs, to be moved up and down the aisles to provide a meal service. Without some form of vertical restraint, it would appear to be only a matter of time before there is a serious accident to a cabin occupant as a result of negative 'g' during unexpected turbulence.

## The In-Flight Fire

Our first priority must be to minimise the risk of the fire. In this regard we have found that a fire engineering zonal analysis of each zone and compartment within the aircraft is a powerful design tool. The analysis must address such things as compartment geometry, choice of materials, types of systems located in the zone, the segregation of ignition sources from materials susceptible to combustion, compartment ventilation and drainage, etc., etc.

However, success, or otherwise, in tackling in-flight fires, depends upon at least *four* important factors.

- (a) The early detection and location of the fire.
  - (b) Compartment design and construction to discourage rapid fire development.
  - (c) Effective use of available extinguishers.
  - (d) Effective means to minimise migration of hazardous smoke and fumes to occupied compartments and achieve rapid smoke clearance.
- (a) The need for early detection may well demand greater use of reliable smoke and fire detectors such as those presently being proposed for use in toilet and galley compartments. Nevertheless we have grave misgivings about the possible use of commercial detectors, unless they have been assessed against an airborne equipment environment. We know from sad experience in other areas that false warnings soon give rise to a loss of faith in the detection system and the inevitable development of a dismissive attitude on the part of the crew with possibly fatal consequences.
- (b) Considering now the compartment design, the rate of spread of fire can be significantly influenced by compartment geometry as well as through the choice of materials. It is important to ensure that the compartment does not possess design features which, in a fire, can act as a chimney and encourage the spread of hot fire gases into other inaccessible areas where the fire can develop. All too frequently we have seen, in hindsight, that this aspect has not been fully addressed. This further emphasises the need for a systematic fire engineering zonal analysis of the aircraft at the early design stage.

- (c) Turning now to the effective use of available hand-held fire extinguishers, the CAA welcomes the proposal to require the increased use of B.C.F. (HALON 1211) extinguishers in occupied compartments. This agent has long been shown to possess probably the highest general fire kill capability of any of the extinguishing agents currently available for use in aircraft cabin fires. Its use has been strongly recommended in the UK over the last 15 years and is probably the most widely used agent in the UK. However, whatever the merits of any one particular agent, any extinguisher, to be effective, must be used by a properly trained crewmember. We believe that "hands on" training is the only way to achieve this.

Now, however good the extinguisher or the training, neither are of much value if the crew cannot reach the source of the fire because of the smoke and irritant fumes. For this reason we are proposing legislation that will require the provisioning of portable protective breathing sets for each of the required cabin crewmembers carried on public transport aircraft. We believe that with such protection, the crew will have a better chance of locating the source of the fire and thereby effectively bringing it under control.

Incidentally, we have looked at passenger protection systems but believe that legislation to require such protection is, at best, premature.

- (d) In order to limit migration of smoke and fumes throughout the occupied compartments and rapidly clear smoke once a fire is extinguished, the airconditioning and pressurisation system play an important part.

We believe that still more could be done to improve both the clearance and migration control using such systems but to do so requires that this subject is addressed at an early stage in both system and installational design.

So far we have talked about accessible in-flight fires. Many cargo compartments are inaccessible and conform to the Class D classification. We fully support the FAA's proposal to upgrade the resistance to fire penetration of the linings of such compartments. We also support the new 1000 cu. ft. volume limit, a limit already stipulated in both BCAR's and JAR 25. We do however, believe that if the fire hardening potential is to be fully realised, fire tests must include an accurate representation of the way in which the lining material is retained in the actual aircraft. One might also question why this new fire test standard should be limited to Class D cargo compartments.

## The Post Crash Fire

There would appear to be two ways to address this subject:

- (a) reduce the likelihood of the post crash fire, or
  - (b) extend survival time within the fuselage in the presence of a post crash fire.
- (a) One possible way of reducing the likelihood of the post crash fire is by the installation of more crashworthy fuel systems and thereby reduce the likely fuel spillage. Another is by the use of Anti-Misting Kerosene. The C.I.D. unfortunately did not live up to expectations and, as we saw, there was the characteristic fireball of burning fuel mist engulfing the aircraft as it came to rest in the desert. A fireball which appeared to be sustained long enough to ignite the spilled fuel around the fuselage.

Whilst clearly we are a long way from finding the optimum solution to fuel misting in a crash where major fuel spillage occurs, work in this field should not be abandoned simply because of a poor showing in a single test.

- (b) If, on the other hand we are also trying to extend passenger survival time, there are at least three areas in which improvements can be sought; —
- i) delay the entry of the fire into the fuselage
  - ii) fire harden the cabin furnishing materials to delay flash-over
  - iii) extend the usable time of escape facilities carried on the aircraft.

- i) A post crash fire will enter the fuselage through any opening such as a door or a fuselage break. Alternatively, it will enter through a cabin window. We have seen how fire penetration can be substantially delayed by the use of a fire hardened secondary window.
- ii) The full scale fire tests on the C-133 at NAFEC have clearly indicated the important part that cabin furnishing materials can play in determining the overall survival time within the occupied compartments and, in particular, the part played by present day seat cushion materials. We therefore fully support the intent of the new seat cushion fire test standards and the present day needs for fire blocking layers to fire harden the seats. We also fully support the future plans to extend this fire hardening criteria to other major cabin materials such as wall and ceiling panels. We do however have some reservations about the type of fire test as currently defined, particularly if such a test were to be extended to other areas. From our own research programme, we believe that radiant panel tests are more controlled and provide the ability to see what is happening to the specimen. It further offers scope for smoke and gas analysis to be measured should this be required in the future.
- iii) To take advantage of this potential increase in survival time, we have seen the introduction of requirements for escape slides with improved radiant heat resistance. To date, this has only been applied to newly designed slides. We still believe that there is scope for applying radiant heat reflective coatings to existing escape slides, thereby extending their survival time in the presence of a fire, albeit to a somewhat lower standard than the new designs. (Perhaps something is better than nothing!)

Recently we have also seen the introduction of floor proximity emergency lighting systems to further assist the occupants in finding the exits under conditions of a smoke filled cabin.

All these features taken together should help to save lives in the post crash environment.

## Summary

In summary, it must be admitted that this cabin safety overview has been strongly biased towards cabin fire safety, for it is in this area we see the greatest scope for further improvements. It has prompted many changes to the regulations in recent times and will no doubt continue to do so in the future, particularly in terms of requirements for material fire hardening.

I am reminded of a fire safety conference some years ago when the following statement was made by one of the speakers addressing the subject of fire and the complexity of trying to quantify the hazards of combustion products. He said:

“For every complex question, there is a simple solution — and it’s always wrong”.

Either there is an exception to that “rule” or we have been trying to answer the wrong question, for it seems to us, at least in part, that fire hardening is the single most likely way to show benefit in improved cabin fire safety not only from the point of view of fire spread but also in limiting smoke and toxic gas evolution, at least in the post crash environment.

Thank you.



**G. F. Marsters**  
**Director, Airworthiness**  
**Canadian Air Transportation Administration**

Dr. G. F. Marsters began his career in aviation in 1952, when he enlisted in the Royal Canadian Air Force and trained as a pilot. He flew F86's in England before returning to Canada to become a pilot-instructor. He studied mechanical engineering at Queens University and Aerospace Engineering at Cornell University where he was awarded the Ph.D. in January 1967. From 1967 to 1982 he taught engineering at Queens University. In 1974/75 he was appointed Senior Industrial Research Fellow at De Havilland Canada Ltd. and in 1981/82 he was a visiting research scientist at the High Speed Aerodynamics Laboratory at the National Aeronautical establishment at Ottawa.

In August 1982 he took up his present duties as Director of Airworthiness, Canadian Air Transportation Administration, Ottawa, Canada.

# SOME THOUGHTS ON CABIN SAFETY

G.F. Marsters

## Introduction

It is a pleasure and an honour to be here today to participate in the early stages of what promises to be a very worthwhile workshop. The program offers thought-provoking material; the whole subject matter demands action-provoking discussion and follow-up. As a manager in a regulatory authority, I am anxious to see action; I am frequently frustrated by the sedate pace at which rulemaking, on both sides of our mutual border, proceeds. While we are ever mindful of safety, we must remember two important ideas:

- (I) Safety must be bought; the quest for safety must not destroy/jeopardize the system in which safety is sought.
- (II) New requirements aimed at enhancing safety must do just that; it is essential that proposed "fixes" not compromise safety through complex interactions with other parts of the system.

To illustrate this second point a bit further, undue haste in proposing a "fix" may well compromise safety. I recall an interview with a very perceptive and probing television news reporter, who, frustrated by the slowness of official response to a catastrophic accident asked me:

"Are you not angry enough to directly impose new rules which will prevent the recurrence of this tragedy?" —

or words to that effect. Unfortunately, I was not quick-witted enough to reply:

"Do you really think the interests of the people are best served by arbitrary, knee-jerk emotional rulemaking by faceless and unaccountable bureaucrats?"

The rulemaker is caught between an acute awareness of urgency of solution and the responsibility to ensure that new rules are realistic, practicable and of net benefit to our citizens.

I expect that the proceedings at this workshop will be largely driven by the events of June 1983 when a Canadian registered, U.S. manufactured aircraft suffered an in-flight fire and landed at Cincinnati. You are all well aware that 23 lives were lost in that accident. One of the major questions facing all of us is:

"Could that number have been 15, or 8 or even zero? How could we achieve zero?"

But, I sincerely hope that in our urgent search for solutions to questions related to the "Big Iron" we do not lose sight of the cabin safety problems which face those who fly in smaller aircraft — the many millions of passengers per year who move about our skies in aircraft designed to normal/utility category standards.

Let me approach some of these problems by looking at some crash scenarios. What follows does not necessarily follow a traditional approach.

Under what particular circumstances is the occupant concerned with cabin safety? Surely the following are cases to consider:

- All engines out - land/water
- Failure of flying controls
- In-flight breakup
- Wind shear/downburst
- Flight into ground

- Loss of control
- In-flight fire
- Runway overrun/undershoot
- Post crash fire

In some of these cases, no conceivable design features could be expected to protect the occupants. Perhaps an objective is that we should be able to assure passengers and crew that if the aircraft is controllable at impact, and that the impact area is reasonably free of obstructions, a high degree of survivability is to be expected. This I will call a benign crash.

Setting aside the questions of in-flight and post crash fire for the moment, let us examine the requirements for survivability. The human body is remarkably well able to accommodate very high accelerations provided these are of short duration. To survive a benign crash, the occupant must be protected from trauma producing forces/collisions. Thus we require:

- (A) Adequate restraint of occupants;
- (B) Protection (integrity of occupant space).

To satisfy the first, the seats, seatbelts and other restraints must be satisfactorily anchored and energy absorbing. If all the seats and occupants are compressed into the forward one-third of the aircraft by a 15 "g" deceleration say, survivability will be low indeed.

Assuming the occupants are suitably restrained, they must be prevented from injury due to invasion of their space by aircraft structure and equipment. I perceive this to be a very significant problem in smaller aircraft. It is little comfort to know that you are securely strapped in if you also know that you will have the engine on your lap and the tailplane wrapped around your neck. In this area, I believe we have a long way to go.

It is encouraging to know that major new initiatives are underway with respect to human resistance to decelerative forces and to crash dynamics. I refer in particular to the FAA's proposed advisory circular regarding injury criteria for human exposure to impact (AC21-XX, Federal Register, 21 September 1984, P 37117-37210).

Assuming survivability, what then? Clearly we need:

- Clear and recognizable escape paths and openings (unobscured, unobstructed and safe)
- Time to evacuate
- Survivability external to the aircraft (water; external fire; arctic environment)

During some brainstorming sessions following the Cincinnati accident, we were concerned about these questions. We thought about such things as: tactile indicators (some aircraft have these, but have you ever been briefed by the cabin crew?); aural signals at exits; high intensity strobe lights at exits. None of these have been rejected outright, and should be reviewed further along with other ideas.

Knowing of the efforts of the FAA with respect to escape path marking and interior materials, Canadian authorities have concentrated on the following:

- Evaluation of candidate crew and passenger breathing masks (15 seconds could be the difference between life and death)
- Improved protection of electrical loads
- Passenger awareness/education programs.

Canadian authorities are in the process of adopting the various measures initiated by the FAA, and we have an active carrier/authority program underway regarding the use of smoke detectors on board aircraft. We are, for the simple reason that virtually all Canadian registered passenger aircraft are built to U.S. standards, staying very close to the FAA with respect to adoption of rules related to cabin safety.



Before I close, may I briefly mention my own pet peeve: carry-on baggage. On each flight, I am astounded and appalled by what passengers are allowed (even encouraged) to bring on board. I feel my personal safety is frequently compromised by this. If you sit between me and the aisle, and your hand baggage in any way impedes my rapid exit, I will politely ask you to move it to a safe place. If you refuse, I will summon the cabin attendants and use whatever influence I may have to correct what I perceive to be an unsafe situation. Each of us, as individual travellers, can join in a campaign to enhance cabin safety.

Finally, I would like to leave you with the following thought: concerning the Cincinatti accident, how could we achieve zero fatalities? While ruminating on this during these three days, bear in mind that safety has a price, and new requirements aimed at improving safety must do just that!

Thank you for your attention. I have appreciated the opportunity to speak to you.

## SESSION II

### CABIN SAFETY INITIATIVES



**Panel Moderator**

**Mack W. Eastburn**

**Senior Director — Safety, American Airlines**

Mr. Eastburn served in the U.S. Air Force for 23 years and spent his last 13 years in positions of safety responsibility. Before retiring, he served for seven years as Director of Safety for Eastern Transport Air Force, Military Air Transport Service. He joined American Airlines in 1963 as their Manager of Flight Safety, and became Director of Safety a year later, and is now Senior Director of Safety.



**John E. Reed**  
**Program Manager, Full Scale Transport**  
**Controlled Impact Demonstration, F.A.A.**

Mr. Reed earned his degree in electronics from the University of Houston in 1956. He spent 12 years in private industry with Collins Radio Company and Martin-Marietta Corporation before joining the FAA in 1968. He is currently based at the FAA Technical Center where he is Program Manager of the FAA/NASA Full Scale Transport Controlled Impact Demonstration.

# CONTROLLED IMPACT DEMONSTRATION: PRELIMINARY RESULTS

John E. Reed

*(Mr. Reed's presentation was by means of two video tapes accompanied by his comments. The first video tape was a review of the Antimisting Kerosene (AMK) Program; the second was of the Crash Impact Demonstration (CID).*

*Presented here are the highlights of those video presentations and Mr. Reed's comments. -- Ed.)*

Prior to showing the video tape, "The FAA/NASA Full-Scale Controlled Impact Demonstration (CID) Program," a review of the CID objectives is in order:

- Antimisting Kerosene (AMK) — verify AMK can preclude ignition upon impact, and demonstrate AMK in an operational fuel/propulsion system.
- Structure (fuselage, wing, floor) — examine structural failure mechanisms and correlate analytical predictions; provide baseline metal crash data to support FAA and NASA composite crash dynamics research; and define dynamic floor pulse for seat/restraint system studies.
- Seat/Restraint System — assess regulatory criteria; evaluate performance of existing, improved, and new lightweight seat concepts; and evaluate performance of new seat attachment fittings.
- Stowage Compartments/Galleys — evaluate effectiveness of existing/improved retention means.
- Analytical Modeling — validation of "KRASH" and "DYCAST" models to transport aircraft, and verify predicted crash test impact loads.
- Cabin Fire Safety — acquire data on seat blocking layers, burn-through resistant windows; and low-level emergency lights.
- Flight Data and Cockpit Voice Recorders — demonstrate/evaluate performance of new FDR/CVR systems, and demonstrate usefulness for accident investigation analysis.
- Flight Incidence Recorder/Electronic Locator Transmitter — demonstrate/evaluate performance of the ejectable U.S. Navy/NATC system.
- Hazardous Materials Package — demonstrate performance of packages in an impact environment.
- Post-Impact Accident Investigation Analysis — assess adequacy of current NTSB forms and investigation procedures.

In order to deliver the experiments through the profile to the impact site, a Remote Control Vehicle (RCV) concept was developed and implemented in the Boeing 720 (which was considered a sophisticated and complex flight control system for the largest remote control drone ever).

With the above CID summary, the following video will provide you an insight into the total program effort.

Now that you have viewed *what was planned* for CID, now let us take a look at *what happened*.

We are perplexed with the AMK impact performance and are deeply involved in detailed data review and analysis of the AMK experiment. At this time, we can say the demonstration of AMK in an operational fuel/propulsion (4 engine/degrader) system was as planned. All four systems operated from start, takeoff, climb to CID racetrack, final approach to impact, again, as planned. A first — AMK operating in four engine systems.

The RCV system operated flawlessly. The aircraft/experiments were delivered to the impact site as planned.

The onboard structural and seat/restraint systems accelerometers and strain-gage data was acquired with onboard tape recorders and via air-to-ground telemetry to ground tape recorders. In fact, the Data Acquisition Systems (2) performed well after impact through slideout, deceleration to a stop. Over 95 percent of the transducers operated.

The ten (10) onboard high-speed motion picture cameras were recovered, the film processed, and the seat/restraint/dummy system film is outstanding. Film was processed from the vertical stabilizer, cockpit/cabin, and nose motion picture cameras. Again — the film is outstanding.

The FDR/CVR's (new plus existing 720 foil) were recovered and data was recorded and appears to be useful. The individual units were sent to Lockheed, Fairchild, Douglas (Sunstrand), and NTSB for data retrieval and analysis. The NATC unit was ejected and transmitted for less than 5 seconds. Detailed performance analysis is in progress.

The hazardous materials packages were recovered and will be analyzed by the FAA and Dow Chemical.

Over 98 percent of the ground/airborne photographic/video coverage cameras operated, film/tape processed, and appears to be extraordinary. The ground high-speed motion picture, video, infrared, stills, and speciality cameras (estimated over \$4 million) operated as planned. The NASA and U.S. Army helicopters acquired motion picture and still films, while the U.S. Navy "CAST-GLANCE" P-3 acquired multiple film and video camera data.

The video you have seen is from selected video scenes only, as over 20 hours of motion picture film is being processed and reviewed, as are thousands of still prints. These data are fantastic and are being reviewed by AMK and structural experimentors alike.

The documentation research and post-impact investigation teams have combined their efforts and will have concluded their detailed photographic/video documentation within 1 week of CID. These teams (systems, structures, propulsion, human factors, crash fire rescue) are staffed by experts from FAA, NASA, NTSB, U.S. Navy, U.S. Air Force, industry, and selected experts related to passenger survival.

A major plus unexpected (but planned) was over 90 minutes of crash fire rescue team video was acquired from prior to deceleration through the total firefighting operations. What an opportunity to develop CFR training films and programs. This documentation plus the firemen's personal description of their experience fighting the fires internal and external, and the onboard 40 seconds of film from the cameras, should allow the evacuation time to be developed.

Each day of data review is bringing to our attention the degree CID success attained. The AMK question has us puzzled, but there is no doubt in my mind a positive response will be forthcoming.

This was the most documented experiment/demonstration ever — and the data will be useful for many years to come — in aircraft safety efforts. The CID has been a contribution to flying safety interests. I know you will agree with me when you have had an opportunity to review the data for yourself.

The CID Team:

FAA Technical Center  
FAA/Ames  
FAA Headquarters  
NASA Headquarters  
NASA Langley Research Center  
NASA Ames Dryden  
Imperial Chemical Industries of America's  
General Electric  
Jet Propulsion Lab

Numerous supporting Government and industry organizations:

Air Force Flight Test Center  
U.S. Navy  
U.S. Army  
RMS/SIMULA  
Lockheed Services  
Dow Chemical  
Bendix  
Pratt & Whitney Aircraft  
Boeing Company  
Jim Matthiesen, B-720 Consultant  
Resdel



**Thomas E. McSweeney**  
**Manager, Aircraft Engineering Division, FAA**

Mr. McSweeney earned his Bachelors Degree in Aerospace Engineering from Northrop University in 1965 and his Masters in 1966 from California Institute of Technology.

He spent 9 years at Northrop Aircraft where he specialized in structural dynamics, vibration and flutter, and acoustics.

He joined the FAA in Los Angeles in 1974 and is presently Manager of the Aircraft Engineering Division in FAA Headquarters.

# FAA CABIN SAFETY ACTIVITIES

Thomas E. McSweeney

This paper discusses the Federal Aviation Administration's (FAA) past, present, and planned near future regulatory activities in the areas of cabin fire safety, crash dynamics, and other occupant protection areas. In addition, it discusses completed and planned activities of a nonregulatory nature that have an impact on occupant protection. This paper also discusses future cabin safety and occupant protection activities, including research and development. Lastly, this paper compares the FAA's activities with the Special Aviation Fire and Explosion Reduction (SAFER) Advisory Committee Recommendations.

## Completed Programs

Since 1980, the FAA has completed several actions that have led to significant improvements in occupant survival as summarized in Table I. These actions improve crash protection, water survival, and flammability protection.

**Flight Attendant Seats and Shoulder Harnesses** — On January 29, 1980, the FAA issued new requirements in the certification and operating rules that provide for improved flight attendant safety. The new requirements were for improved flight attendant upper torso support, shoulder harnesses with a single point release, and improved galley restraint requirements where a flight attendant is located in proximity to the galley. The rule retroactively applies the new criteria to existing aircraft and required compliance by March 6, 1982. On December 4, 1981, the FAA also issued Advisory Circular (AC) 25.785-1, Flight Attendant Seat Requirements, which identifies acceptable criteria for compliance with the new rule.

**Child Restraints** — On May 28, 1982, the FAA issued Technical Standard Order (TSO) C100 which provides criteria for approval of child restraint devices for use aboard aircraft. The TSO requires compliance with the Federal Motor Vehicle Safety Standard (FMVSS) No. 213, Child Restraint Systems, and three additional test requirements that are representative of the unique aircraft environment. To date, 36 models of child restraint devices have been TSO approved for use in aircraft. Considering newly manufactured devices and those already in service, that amounts to approximately 3.5 million child restraint devices.

In addition, the FAA and the National Highway Traffic Safety Administration (NHTSA) tested virtually all non-TSO-approved devices to the criteria found in TSO-C100. All devices passed the test. As a result, the FAA plans to issue an advisory circular indicating that virtually all models of child restraints are acceptable for use on aircraft, as long as they contain the FMVSS No. 213 label. The FAA and NHTSA also embarked on a program to revise FMVSS No. 213 to include the criteria of TSO-C100 so that certification to the new FMVSS No. 213 by the manufacturers would result in seats approved for use in aircraft as well as automobiles. The revised FMVSS No. 213 becomes effective February 26, 1985. The FAA also plans to cancel TSO-C100 in the near future and accept new FMVSS No. 213 as the sole specification necessary for child restraints to be approved for use in aircraft.

**Life Preservers** — Improved requirements for life preservers to be used aboard aircraft, contained in TSO-C13d, were issued on January 3, 1983. The improvements include a donning requirement of 15 seconds unassisted while seated, a 30-second donning requirement on a child or infant by another adult, increased buoyancy and flotation attitude requirements, and the creation of an infant category of life preservers. The TSO, in addition, requires that after January 3, 1985, no previously approved TSO-C13 designs may be marked as FAA TSO-approved. This, in effect, requires all newly purchased life preservers for airline use to meet the improved standards. As discussed later in this paper, the FAA is reevaluating the adequacy of TSO-C13d and has initiated a program to require life preservers on all air carrier aircraft.

**Emergency Evacuation Slides, Ramps, and Slide/Raft Combinations** — On June 3, 1983, the FAA issued TSO-C 69a which made general improvements to the equipment requirements and contained new criteria to improve the radiant heat resistance of the equipment. The new criteria significantly improve the ability of these passenger evacuation devices to remain operative in the presence of reasonably close, large, fuel-fed fires. The revised TSO requires that after December 3, 1984, devices which do not meet the new radiant

heat criteria can no longer be marked as FAA TSO-approved. This has the effect of requiring all newly purchased evacuation slides for airline use to meet the improved standards. Many of the recently manufactured airplanes have the improved devices installed, and the FAA will be closely monitoring the voluntary upgrading of the inservice fleet to ensure that reasonable retrofit of the improved devices takes place. Mandatory retrofit has not been sought by the FAA, since past accident statistics cannot justify, at this time, the cost of a fleet-wide retrofit.

**Crewmember Protective Breathing Equipment** — The FAA, on June 27, 1983, issued TSO-C99 which established criteria for the protective breathing equipment for air transport flight crewmembers. This TSO uses as its basis an SAE Aerospace Standard, which itself is based upon research and development accomplished at the FAA Civil Aeromedical Institute (CAMI). The new standard requires a full-face oxygen mask or a combination smoke goggles and oxygen mask with positive purging of the smoke goggles to preclude fogging or the buildup of irritant gases that might impair vision. As discussed later in this paper, a notice of proposed rulemaking will be issued to require all aircraft operated under Part 121 of the Federal Aviation Regulations (FAR) to be equipped with protective breathing equipment that meets the new TSO.

**Hand-held Fire Extinguishers** — Revised Advisory Circular No. 20-42C, Hand Fire Extinguishers for Use in Aircraft, was issued August 25, 1982, which updated selection criteria for hand-held fire extinguishers in all types of aircraft. The revision incorporates the latest information and data regarding Halon 1211 fire extinguishers. These extinguishers have superior knock-down capability compared with earlier types of fire extinguishers. In addition, the FAA encouraged airlines to install at least one Halon 1211 fire extinguisher in the aircraft cabin. This encouragement was followed by a later NPRM to require at least two hand-held Halon 1211 extinguishers in air carrier airplanes.

### **Present Activities — Fire Safety**

The FAA has ten activities in the area of fire safety, as shown in Table II, which encompass cabin fire protection, cabin evacuation in the presence of smoke and fire, cargo compartment fire protection, and fire hardening of aircraft systems.

**Seat Cushion Fire Blocking Layer** — The FAA on October 26, 1984, published new standards which will significantly reduce the flammability of present-day foam seat cushions. The standards contain new laboratory test and acceptance criteria that were developed as a result of extensive full-scale testing at the FAA Technical Center. The tests are representative of a post-crash, high intensity fuel fire (10 BTU/FT<sup>2</sup>-SEC). Full scale testing has shown that aircraft seat cushions designed to meet these criteria delay the onset of ignition within the cabin and reduce the spread of flame and products of combustion, such that at least 40 seconds in post-crash evacuation and survival time can be gained through the use of these new cushions. Cushions of materials that meet the new standard will significantly reduce the spread of in-flight fires as well. The rule requires that all seat cushions on existing airplanes type certificated after 1958 comply with the new standards within 3 years.

**Smoke Detectors and Fire Extinguishers** — On May 17, 1984, the FAA published proposed standards for air carrier airplanes that would require each lavatory and galley to be equipped with a smoke detector system, that each lavatory trash receptacle be equipped with an automatic fire extinguisher, and an increased number of fire extinguishers, at least two of which must contain Halon 1211 as the extinguishing agent. A compliance time of 1 year after issuance of the final rule is proposed. The FAA expects to complete its final action on the proposals by December 31, 1984, at which time the regulatory package will enter Executive Branch coordination.

**Interior Materials** — The FAA is in the final stages of completion of a proposal for improved flammability standards for transport airplane cabin interiors. The proposal contains new test criteria that are based upon recent, full-scale tests conducted at the FAA Technical Center. The criteria focus on the reduction of material flammability which, in turn, automatically reduces smoke and toxic byproducts. The new interior materials that meet this proposed standard, when combined with the improved seat materials, should greatly reduce the spread of fire within the airplane cabin as a result of both post-crash and in-flight fires. The regulatory package will contain a scheme for inclusion of these materials into newly manufactured



airplanes and some airplanes in service. The FAA plans to complete action on the NPRM by December 31, 1984.

**Crewmember Protective Breathing** — The FAA has completed action on a notice of proposed rulemaking to improve the protective breathing equipment for crewmembers serving under Part 121 of the FAR. The notice is presently undergoing Executive Branch coordination. The proposal would require that all protective breathing equipment for flight deck crew meet, within a 1-year time period, the otherwise optional standards of TSO-C99. It would also provide for equivalent portable protective breathing equipment for flight attendants to assist in fighting fires and would require "hands on" training for all crewmembers in fighting typical aircraft fires. Up to 2 years is being proposed to allow for air carriers to train all of their crewmembers.

**Passenger Protective Breathing Equipment** — Approximately 6 months ago, the FAA decided to reevaluate the appropriateness of the various types of protective breathing devices being proposed as the solution to in-flight and post-crash protection of passengers from smoke and toxic fumes. The FAA has completed its staff study which basically shows that there are no devices presently on the market which protect the passengers that do not have equally serious failings.

Smoke hoods have been shown to increase evacuation time significantly when used for the post-crash fires. When used for in-flight fires, these devices must have self-contained oxygen supplies, or the aircraft oxygen system must be significantly redesigned to provide oxygen to these devices. The smoke hoods will not function as breathing devices in the event of a sudden decompression, so they would have to be in addition to the present devices. Another type of device that hooks to the small individual passenger air outlets does not have very widespread application. Many aircraft are capable of providing only recirculating cabin air to these outlets, other outlets (as the center seats on the Lockheed L-1011 airplane) are not reachable due to the high ceiling, and more importantly, many airplanes are being manufactured without these outlets. The last type of device is a rebreather bag that hooks directly to the present decompression oxygen mask. Testing by the FAA initially showed some promise for this device, although significant changes to the airplane oxygen system would be necessary to accommodate the 100 percent oxygen demands at all altitudes for approximately 20 minutes. Recent tests by the FAA indicate problems with the mask properly sealing against the face at high cabin pressure altitudes.

With the many efforts undertaken to fire harden the cabin, the need for these devices has diminished. To be discussed later, research and development of a method to purge the airplane of smoke and toxic fumes while in flight shows more promise of a solution than individual passenger protective breathing devices.

Thus, the FAA sees little merit in developing or mandating such devices. We will, though, evaluate new designs and design standards for possible inclusion in a TSO should the industry itself decide to pursue this matter further.

**Floor Proximity Emergency Escape Path Marking** — The FAA on October 26, 1984, published new standards for floor proximity emergency escape path marking that will provide visual guidance for emergency cabin evacuation when all sources of cabin lighting more than 4 feet above the aisle floor are totally obscured by smoke. The standards result from research that shows such markings significantly increase the ability of passengers to evacuate in smoke-filled aircraft. The rule requires all inservice airplanes type certificated after 1958 to comply with the new design standards within 2 years.

**Class D Cargo Compartments** — On August 8, 1984, the FAA published proposed standards to improve fire safety in Class D cargo and baggage compartments. The proposed standards upgrade the fire test criteria for the Class D compartment ceiling and wall liners and limit the total size of Class D compartments to 1,000 cubic feet. The proposals resulted from full-scale testing of typical compartments to establish criteria representative of "typical" fires and the development of a laboratory test that properly simulates those fires. The FAA has recently reopened the comment period which presently closes on January 8, 1985. The FAA plans final action on the proposals by early 1986.

**Transport Airplane Automatic Fuel Shutoff** — On September 4, 1984, the FAA issued an advanced notice of proposed rulemaking to request comments and proposals on fuel system protection during post-crash

ground fires, especially the shutoff of fuel when post-crash ground fires occur. The comment period closes January 25, 1985.

**Small Airplane Crash-Resistant Fuel Systems** — The FAA has completed, on November 26, 1984, an advance notice of proposed rulemaking (ANPRM) to request comments and proposals on crash-resistant fuel tanks, lines, and fittings. The ANPRM is presently in Executive Branch coordination. This ANPRM is the beginning of the agency's regulatory action to develop improved crash-resistant fuel system standards for small airplanes. This will allow time for the FAA Technical Center and the National Transportation Safety Board to develop data needed to resolve current issues. The General Aviation Safety Panel has also agreed to study crash-resistant fuel systems and provide recommendations to the FAA. The ANPRM will also request information on those questionable areas from other members of the aviation community who may not be able to participate in the General Aviation Safety Panel, National Transportation Safety Board, and FAA Technical Center efforts; it will also request cost information needed to support later regulatory action.

### Present Activities — Water Survival

As shown in Table III, the FAA has three basic programs in the water survival area.

**Overwater Staff Study** — On September 19, 1984, the FAA published a notice in the *Federal Register* announcing the availability of a recently completed staff study on water survival and requested comments on its content. The staff study was a 3-year effort to compile statistics and details on water accidents, to address the factors that possibly lead to deaths from drowning, and to discuss what are the most feasible and effective solutions to improved water survival. The FAA is very eager to receive comments on the staff study so that public views may be considered when proceeding with the two initiatives discussed next. While the comment period has closed, interested persons should still continue to submit comments.

**Revised TSO-C13** — Although the present TSO-C13d was just revised in January 1983 to provide for improved donning, some questions have been raised whether life preservers meeting the new TSO are indeed easier to don. The FAA has begun studying ways to further improve the donning of life preservers and whether some improved flotation characteristics can be achieved as well. The FAA expects to be able to propose a new draft TSO by June 1985.

**Air Carrier Life Preservers Equipage** — The FAA has initiated a program aimed at requiring life preservers on all air carrier aircraft, regardless of their route structure, and requiring a preflight briefing on the use of these devices prior to each flight. The specific details of the program have not been fully developed at this time, as the FAA is awaiting comments from the water survival staff study.

### Present Activities — Crash Dynamics

There are several elements of the FAA crash dynamics program, all of which are aimed at increased survivability of the occupant in typically survivable accidents. The last five activities in Table IV are the result of an over 4-year effort to improve occupant survivability in aircraft seats when subjected to the accelerations resulting from typical survivable accidents. Each of the activities is discussed in more detail.

**General Aviation Shoulder Harnesses** — The FAA is finalizing action on an NPRM to require shoulder harnesses to be installed at all seats in small airplanes with a passenger seating configuration of nine seats or less that are manufactured after a specified date. Presently, shoulder harnesses are only required on the front seats of small airplanes manufactured after July 19, 1978. The proposal is the culmination of efforts by the FAA and a recent petition for rulemaking by the General Aviation Manufacturers Association. In addition to the above regulatory proposal, the FAA is encouraging all airplane owners to retrofit shoulder harnesses in existing airplanes and many of the airplane manufacturers have developed or will be developing shoulder harness retrofit kits. The FAA is also preparing an advisory circular to discuss shoulder harness installation criteria and installation guidelines. All of these actions should result in increased use of shoulder harnesses and an associated decrease in the loss of lives during survivable accidents.

**Shoulder Harness TSO** — As a companion to the shoulder harness NPRM, the FAA requested the SAE to form an ad hoc committee to develop criteria for shoulder harnesses for inclusion in a new TSO. Representatives from industry and the government are on the committee, and a draft SAE standard has been prepared. Once the standard is approved, the FAA concurrently expects to issue a draft TSO for public comment, which is expected to occur by March 1985.

**Human Tolerance Advisory Circular and Program Definition** — The FAA issued on September 21, 1984, a notice in the *Federal Register* announcing the elements of its crash dynamics program leading to improved seat standards (discussed in more detail later) and the availability of a draft advisory circular (AC) that discusses what the FAA considers to be reasonable human tolerance criteria for use in evaluating human survivability. It is expected that the human tolerance values in the AC will be used, either directly in the rule or by reference to the AC, as pass/fail criteria when dynamically testing passenger seats. The FAA seeks comments on the proposed AC from all interested parties and expects final action on the AC in June 1985.

**Seat Dynamic Standards** — The FAA is presently defining and developing new seat standards for general aviation, transport, and rotorcraft aircraft. These are in the form of dynamic test criteria that are representative of typically survivable accidents, with a different test criteria for each type of aircraft due to the different crash scenarios and accelerations experienced by each. At present, the FAA envisions a rule that in effect consists of a representative dynamic test and a performance standard that uses the defined human impact tolerance as the pass-fail criteria. The FAA expects to complete its action on a notice of proposed rulemaking by June 15, 1985.

**Dynamic Test Guidelines for Aircraft Seats** — The FAA is preparing an extensive AC (or possibly three separate AC's) that outlines for each type of aircraft, information that is essential for a complete understanding of how the FAA arrived at the proposed new seat standards and what methods of compliance will be acceptable. While the AC is not finalized yet, it is certain to contain discussions of how the improved seat standards were developed, the types of accidents considered, the types of aircraft considered, and how to arrive at equivalent seat test criteria should the industry develop aircraft that are untypical of those used to develop the regulatory standards. The AC will be published for comment with the seat dynamic standards notice (discussed above) to allow for a more comprehensive understanding by commenters of the agency's intentions and, hopefully, to stimulate more complete comments.

**Analytical Modeling Techniques** — The FAA is developing an AC that summarizes the types of analytical modeling techniques available and what types of analyses would be necessary and sufficient to demonstrate compliance with the new proposed seat standards. The AC too will be published for comment with the previously discussed AC and NPRM.

**Seat TSO** — Once the new seat standards are developed, it will be necessary to develop a new TSO for aircraft seats that embodies the proposed new dynamic test criteria. This will enable manufacturers to continue to market FAA TSO-approved seats and enable the operators to purchase replacement seats directly from the manufacturer. Since the seats may change significantly from aircraft to aircraft because of the dynamic response of a particular aircraft/seat/shoulder harness combination, there are still some issues with this TSO concept that remain to be resolved. The FAA anticipates issuance of a draft TSO for comments concurrently with the NPRM for improved seat standards.

## **Future Activities**

With all the actions which have been discussed, there is a strong tendency to keep up the high activity pace of the last 4 years and press on to newer things. One has to use some caution though. By the middle of 1986, we will have completed action in the fire safety area to introduce more fire-resistant materials in evacuation slides, seats, cabin interiors, and cargo compartments. We will have completed action to require smoke detectors in all lavatories, automatic fire extinguishers in trash bins, protective breathing equipment for crewmembers, at least two halon 1211 fire extinguishers per aircraft, and air crew "hands on" training at extinguishing typical aircraft fires. All these combined should result in a much-improved fire safety record. It will not have been achieved though without a very significant expense by the airplane builders and operators; an expense that we believe is warranted by the benefits accrued. With the present excellent

safety record in air carrier aircraft, it will be a long time before we will be able to confirm this expected improvement in aircraft safety and make the final validation of the merits of our efforts. We have made a very significant (some may argue quantum) increase in safety, and we must confirm its validity in the real world of air transportation.

There are several areas, though, that the FAA believes it must investigate in its research. We are presently completing research on the flammability requirements for Class C cargo compartments. We also plan to complete the needed research on the best method of removing smoke from the airplane during in-flight fires in order to improve in-flight survivability and to reduce the possibility of flashover once on the ground when the doors are opened. Composite materials must also be looked at both from a flammability and a crashworthiness standpoint.

These are the more significant efforts planned, but the FAA intends to be vigilant to new efforts to improve occupant safety as dictated by service experience.

### Safer Revisited

Table V presents the SAFER recommendations made in 1980, and the FAA action on each. As can be seen, the FAA has been responsive to each recommendation in some manner, and on the whole has accomplished most actions recommended.

### Summary

The FAA is presently in the final regulatory phase of a very aggressive program to improve the level of safety for the traveling public and owners of small aircraft. A quick glance at Tables I through IV shows that since 1982, 25 activities have been completed or will be completed by mid 1986. Many of these activities are a result of major research and development by the FAA, including the construction of an unprecedented full-scale fire test facility. Many of the new regulations *will be costly, to both the aircraft owner/operators and the traveling public*. Full-scale testing has shown, though, that these new occupant protection requirements *will save lives*. Much of this present regulatory program was envisioned by the FAA and the SAFER Committee as early as 1980, and major elements of the FAA cabin fire safety and crash dynamics programs have been completed virtually on schedule. There has been some redirection of efforts (for instance, the combined hazard index did not work out), but the well-defined and scientifically based FAA programs have proven their worth and soundness in full-scale testing, and we predict will prove effective in saving lives.

**TABLE I  
FAA COMPLETED PROGRAMS**

ACTIVITY	1980	1981	1982	1983	1984	1985
<u>CRASHWORTHINESS</u>						
● Flight Attendant Seats and Shoulder Harnesses						
1. Regulatory Action	▲ JAN	▲ DEC	● MAR			
2. Advisory Circular		▲ DEC	▲ MAY			
● Child Restraints, TSO-C100						
<u>WATER SURVIVAL</u>						
● Life Preservers, TSO-C13d		◆ OCT		▲ JAN		○ JAN
<u>FLAMMABILITY</u>						
● Emergency Evacuation Slides, Ramp 2, and Slide/Raft Combinations, TSO-C69a		◆ NOV				○ DEC
● Crewmember Protective Breathing, TSO-C99		◆ NOV		▲ JUN		
● Hand-Held Fire Extinguishers, AC 20-4B		◆ NOV	▲ AUG	▲ JUN		

Key:  
 ◆ ANPRM, NPRM, or Document Issued for Comments  
 ▲ Final Action  
 ○ Effectivity Date  
 ▲ Open Symbol: Pending Action  
 ▲ Closed Symbol: Completed

**TABLE II  
FAA FIRE SAFETY PROGRAMS**

ACTIVITY	1983	1984	1985	1986	1987
<u>CABIN FIRE PROTECTION</u>					
● Seat Cushion Fire Blocking Layer - Rule	◆ OCT	▲ OCT			○ NOV
● Smoke Detectors, Automatic Fire Extinguishers in Trash Bins, and Portable Halon Fire Extinguishers - Rule		◆ MAY ▲ DEC	○ DEC		
● Interior Materials - Rule		◆ DEC	▲ DEC		
● Crewmember Protective Breathing - Rule		◆ OCT	▲ DEC		
● Passenger Protective Breathing - Staff Study Report		▲ OCT			
<u>CABIN EVACUATION</u>					
● Floor Proximity Emergency Escape Path Marking - Rule	◆ OCT	▲ OCT			○ NOV

**TABLE II (Continued)  
FAA FIRE SAFETY PROGRAMS**

ACTIVITY	1983	1984	1985	1986	1987
<u>CARGO COMPARTMENT</u>					
● Class D Compartments - Rule		◆ AUG		▲	
<u>AIRCRAFT SYSTEMS</u>					
● Transport Automatic Fuel Shutoff - ANPRM		◆ SEP			
● Small Airplane Crash-Resistant Fuel Systems - ANPRM		◆ NOV			
● Anti-Misting Kerosene (AMK)					

Key:

◆ ANPRM, NPRM, or Document Issued for Comments

▲ Final Action

○ Effectivity Date

▲ Open Symbol: Pending Action

▲ Closed Symbol: Completed

**TABLE III**  
**FAA WATER SURVIVAL PROGRAMS**

ACTIVITY	1983	1984	1985	1986	1987
● Overwater Staff Study - Report		◆ SEP			
● Revised TSO-C13			◆ JUN	▲ MAR	
● Air Carrier Life Preserver Equipment					

**Key:**

- ◆ ANPRM, NPRM, or Document Issued for Comments
- ▲ Final Action
- Effectivity Date
- ▲ Open Symbol: Pending Action
- ▲ Closed Symbol: Completed



**TABLE IV  
FAA CRASH DYNAMICS PROGRAMS**

ACTIVITY	1984	1985	1986	1987	1988
● G/A Shoulder Harnesses - Rule	◇ DEC	△ JUN			
● Shoulder Harness TSO		◇ MAR SEP			
● Human Tolerance and Program Definition - AC	◇ SEP	△ JUN			
● Seat Dynamic Standards: G/A, Transport and Rotorcraft - Rule		◇ JUN	△ MAR		
● Dynamic Test Guidelines for Aircraft Seats - AC		◇ JUN	△ MAR		
● Analytical Modeling Techniques - AC		◇ JUN	△ MAR		
● Seat TSO		◇ JUN	△ MAR		

Key:

◇ ANPRM, NPRM, or Document Issued for Comments

△ Final Action

○ Effectivity Date

△ Open Symbol: Pending Action

▲ Closed Symbol: Completed

## TABLE V FAA ACTION ON SAFER RECOMMENDATIONS

RECOMMENDATIONS	ACTION
<ul style="list-style-type: none"> <li>● INVESTIGATE AND VALIDATE AMK</li> <li>● AMEND PART 25 TO REQUIRE FUEL VENT PROTECTION</li> <li>● AMEND PART 25 TO REQUIRE ENGINE FUEL SUPPLY SHUTOFF</li> <li>● INVESTIGATE REDUCED FLASH POINT OF KEROSENE FUELS</li> <li>● REQUEST NTSB TO IMPROVE ACCIDENT REPORTING RELEVANT TO POST-CRASH FUEL FIRES</li> <li>● EXPEDITE FAA/NASA RESEARCH TO ESTABLISH REALISTIC CRASH SCENARIOS</li> <li>● DEVELOP FUEL SYSTEM DESIGN CRITERIA FOR TRANSPORT AIRCRAFT TO MINIMIZE POST-CRASH FIRES</li> </ul>	<ul style="list-style-type: none"> <li>● R&amp;D LEADING TO CID</li> <li>● ANPRM ISSUED 9/4/84 (F.R. 9/26/84)</li> <li>● ANPRM ISSUED 9/4/84 (F.R. 9/26/84)</li> <li>● R&amp;D LEADING TO CID</li> <li>● NEW NTSB ACCIDENT INVESTIGATION FORM IMPLEMENTED IN 1984</li> <li>● THREE CRASH SCENARIO REPORTS ISSUED IN 1982</li> <li>● AWAITING RESPONSES TO ANPRM</li> </ul>

**TABLE V (Continued)  
FAA ACTION ON SAFER RECOMMENDATIONS**

RECOMMENDATIONS	ACTION
<ul style="list-style-type: none"> <li>● ESTABLISH CONTRIBUTION OF CABIN INTERIOR MATERIALS TO THE POST-CRASH FIRE HAZARD</li> <li>● DEVELOP FIRE BLOCKING LAYERS FOR POLYURETHANE FOAM CUSHIONING MATERIAL</li> <li>● EXPEDITE DEVELOPMENT OF USU CHAMBER AND DEVELOPMENT TEST FOR FLAMMABILITY, SMOKE, AND TOXICITY</li> <li>● AMEND PART 25 AFTER ASTM MODIFIES BUNSEN BURNER TEST TO ACCOUNT FOR MELT AND DRIP AWAY OF MATERIALS</li> <li>● DEFINE POST-CRASH FIRE SCENARIOS AND ESTABLISH THEIR APPLICABILITY TO FIRE MODELING, RESEARCH, AND DESIGN</li> </ul>	<ul style="list-style-type: none"> <li>● COMPLETED AS PART OF SEAT FIRE BLOCKING AND INTERIOR MATERIALS RESEARCH</li> <li>● COMPLETED AMENDMENTS ISSUED OCTOBER 1984</li> <li>● FULL-SCALE TESTS IN C-133 INDICATE THAT IF FLAMMABILITY IS REDUCED, OTHER PARAMETERS NOT SIGNIFICANT. INTERIOR MATERIALS NPRM TO BE ISSUED IN DECEMBER 1984 TO INCLUDE MODIFIED OSU TEST.</li> <li>● NO LONGER NECESSARY AS NEW TESTING METHODS HAVE BEEN DEVELOPED FOR IMPROVED SEATS, CABIN INTERIOR MATERIALS, AND CARGO COMPARTMENT LINERS</li> <li>● FIRE SCENARIO STUDIES USED EXTENSIVELY FOR FULL-SCALE FIRE TESTING AND SUBSEQUENT CRITERIA DEVELOPMENT</li> </ul>

**TABLE V (Continued)  
FAA ACTION ON SAFER RECOMMENDATIONS**

RECOMMENDATIONS	ACTION
<ul style="list-style-type: none"> <li>● CONTINUE TO EXPEDITE AND COORDINATE FULL-SCALE FIRE TEST PLANS</li> <li>● ANALYTICAL POST-CRASH AIRCRAFT FIRE MODELING</li> </ul>	<ul style="list-style-type: none"> <li>● FULL-SCALE FIRE TEST FACILITY COMPLETED, AND MOST FULL-SCALE TEST ACTIVITY COMPLETED</li> <li>● LIMITED USE OF MATH MODELING. PHYSICAL MODELING USED EXTENSIVELY IN FIRE SCENARIO DEVELOPMENT</li> </ul>
<ul style="list-style-type: none"> <li>● IMPROVE RADIANT HEAT RESISTANCE STANDARDS FOR EVACUATION SLIDES</li> </ul>	<ul style="list-style-type: none"> <li>● TSO-C69A ISSUED JUNE 1983</li> </ul>
<ul style="list-style-type: none"> <li>● PROMOTE OPEN FORUMS, DOCUMENTS AND PRESENTATIONS TO MAKE TOXICOLOGY ISSUES MORE UNDERSTANDABLE</li> <li>● ENCOURAGE DEVELOPMENT OF CABIN INTERIOR MATERIALS DATA BANK</li> </ul>	<ul style="list-style-type: none"> <li>● SEVERAL MEETINGS SCHEDULED BY THE FAA TECHNICAL CENTER AND NUMEROUS REPORTS ISSUED</li> <li>● DATA BANK IN USE AT TSC FOR RAPID TRANSIT VEHICLES. INCLUDES DATA ON AIRCRAFT MATERIALS SUFFICIENT FOR FAA NEEDS</li> </ul>

**TABLE V (Continued)  
FAA ACTION ON SAFER RECOMMENDATIONS**

RECOMMENDATIONS	ACTION
<ul style="list-style-type: none"> <li>• SUPPORT CONTINUED DEVELOPMENT OF MATERIALS TO ACCOMPLISH LONG-TERM IMPROVEMENTS IN CABIN FIRE SAFETY</li> </ul>	<ul style="list-style-type: none"> <li>• NUMEROUS MATERIALS TESTED AT THE TECHNICAL CENTER SU FAK AND STATE-OF-THE-ART MATERIALS CONTINUALLY EVALUATED AS THEY ARE MADE AVAILABLE</li> </ul>
<ul style="list-style-type: none"> <li>• EVALUATE SMOKE MASKS AND PROTECTIVE CLOTHING FOR CREWMEMBERS TO AID IN POST-CRASH EMERGENCY EVACUATION</li> </ul>	<ul style="list-style-type: none"> <li>• BOTH WERE INVESTIGATED AND NEITHER PROVED TO BE WORTHWHILE. PROTECTIVE BREATHING EQUIPMENT TO BE PROVIDED TO THE CREW TO ASSIST IN FIGHTING FIRES</li> </ul>
<ul style="list-style-type: none"> <li>• FAA AND NTSB SHOULD IMPROVE AND STANDARDIZE POST-CRASH ACCIDENT INVESTIGATION</li> </ul>	<ul style="list-style-type: none"> <li>• NEW NTSB ACCIDENT INVESTIGATION FORM IMPLEMENTED IN 1984</li> </ul>
<ul style="list-style-type: none"> <li>• ESTABLISH TECHNICAL ADVISORY BOARD TO PROVIDE SPECIALIST ADVICE</li> </ul>	<ul style="list-style-type: none"> <li>• WHILE NO FORMAL BOARD HAS BEEN ESTABLISHED, THE FAA HAS SOUGHT TECHNICAL ADVICE FROM NASA, THE INDUSTRY, AND ALL KNOWN SOURCES OF SUCH KNOWLEDGE. EXPERTS INVITED TO TECHNICAL CENTER TO COMMENT ON RESEARCH</li> </ul>

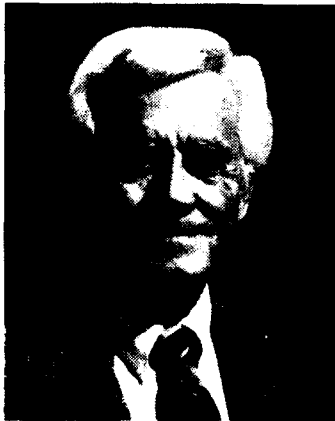

**Dr. Richard K. Brown**  
**Institute of Safety and Systems Management**

Dr. Richard K. Brown, Associated Executive Director for Extension and In-service Programs at the University of Southern California's Institute of Safety and Systems Management, has had extensive experience in specialized education. He served as Chief of the Education Branch of the United States Air Force Directorate of Aerospace Safety, Director of Academics in Pilot Training and Director of Personnel Plans at the Air Force Academy before coming to the University of Southern California.

Dr. Brown has studied and lectured extensively in the area of Aviation Psychology and is trained in Accident Investigation and Aviation Safety Program Management. His professional affiliations include the American Psychological Association and the International Society of Air Safety Investigators.

## ANNUAL INTERNATIONAL AIRCRAFT CABIN SAFETY SYMPOSIUM

Richard K. Brown

For some years now the commercial airline industry has undergone tremendous change. When you think that only a mere 30 years ago it took over ten hours to fly here (Washington) from Los Angeles and we had no commercial jet aircraft in operation until about 1958 — just 26 years ago, the problems we've come here to address seem a little more understandable.

The changes made by the manufacturers were mainly in the areas of cockpit automation — autopilots, inertial navigation systems, radar/map overlays, and warning systems for example. The marketing folks insisted on larger airplanes with more seats and more space for passenger carry-ons. During this time little attention was paid to the change in work place for the cabin crew. With the advent of the wide-bodied aircraft in 1970, the problems of safety in the cabin especially increased in magnitude.

Patricia Goldman pointed out the lag in Cabin Safety design so clearly in her address to the First Annual International Aircraft Cabin Safety Symposium at USC in February of this year. "Seat strength virtually the same now as in 1954. Life vest design, unchanged, and passenger emergency briefings still seriously deficient". And, at the same time, more passengers to serve and more carry-ons encouraged by marketing.

Various groups of Flight attendants have been working in recent years to get someone's attention to improve the working environment and cabin safety. They have worked hard and developed a very professional approach to presenting their case on most issues. Unfortunately to many management organizations, the word "Union" seemed to be a red flag and in spite of the best intentions and good presentation, recommendations often fell on biased and deafened ears.

Over the last fifteen years I began to notice the presence of Flight Attendants at the professional meetings of safety organizations such as the Flight Safety Foundation Annual Seminar, ISASI and others. One is now enrolled in our Aviation Safety Certificate Program on campus. In talking with several of them it became clear that they had a lot to say and needed a place to say it. The personnel in the Cabin were the only group in the aviation industry, prior to our first USC symposium, which did not have a collective and universal meeting at which to present and discuss the issues that concerned them.

Some early attempts to interest some Flight Attendant Organizations in a joint venture in Cabin Safety courses failed for various reasons but finally, in 1983, a Planning Group was formed and the ground work laid for the first USC Symposium. The sole objective was to improve cabin, cockpit and management coordination and cooperation. We believed a forum provided by an outside Institution, such as the University of Southern California, with no membership or other special interest group pressures, could most effectively help to bring about the changes and improvements desired.

As everyone in this room knows, dissention has grown between people in management, the cabin and the cockpit over the years and I believe it is one of the major factors standing in the way of advancement in airline cabin safety.

This Flight Safety Foundation Seminar and our annual Symposia will go a long way to help break down these barriers. One of the objectives of our planning committee for the USC event is to balance the speakers evenly between the various factions. Four of the 23 speakers in 1984 represented unions, and two were "cockpit" people. It is difficult to ascertain from enrollment data just who is management and who is not. Management from a number of major airlines was represented, however,

I'm very happy to report that the First Annual International Cabin Safety Symposium was acclaimed a resounding success. Here is the agenda:

# FIRST ANNUAL INT'L AIRCRAFT CABIN SAFETY SYMPOSIUM AGENDA

## Opening Session

"Aircraft Cabin Safety: Fire Isn't The Only Hazard"  
Ms. Patricia Goldman, Vice Chairman,  
National Transportation Safety Board

Panel Session 1: **CABIN DESIGN/TRAINING**

Panel Session 2: **PERSONAL WELLNESS**

Panel Session 3: **PASSENGER HEALTH AND IN-FLIGHT CARE**

Panel Session 4: **SURVIVABILITY**

Panel Session 5: **CABIN, COCKPIT, AND MANAGEMENT COORDINATION**

A frequent comment following the meeting was, "It was long overdue," or "We need this kind of exchange to continue." There were over 300 people in attendance from 55 organizations and 25 countries around the world. About half were from foreign carriers. As a group, the participants were especially positive, suggesting improvements and direction for next year in their written critiques:

## EVALUATION QUESTIONNAIRE

1. Was there a specific session of the Symposium that you felt more valuable than any other? If so, describe and state why.

	U.S.	Other	Total
Cabin Design/Training	6	8	14
Personal Wellness	20	7	27
Pax Hlth-In-Flt Care	10	0	10
Survivability	37	14	51
Cabin-Cockpit-Mgmt. Coord.	35	20	55

2. Was there a particular session that you feel could have been omitted. Which one and why?

Interior Design	6		
Invisible Injury	3		
(7 other items were mentioned but by less than three people)			

3. On which area would you like further information in future symposiums?

	U.S.	Other		U.S.	Other
Design	6	5	Psych.	5	1
CAMI	3	1	Stress	6	1
Pax Ed	7	0	FAA	8	1
Coordination	5	5	Health	12	3
Emergencies	5	5	Mgmt.	12	4
Cockpit	2	2			



## EVALUATION QUESTIONNAIRE (Continued)

4. Are there any subjects you would like added to future symposiums?

Small Carriers	6	2	Comm.	8	3
Communications	8	3	Hijack/Bomb	5	0
Manufacturers	1	5	FAA	6	0
Training	12	12	Invest.	4	0

5. Additional Comments:

Too Union	7	7	More Int'l.	14	25
More Workshops	4	2	Accolades	20	20
More Pragmatic	9	8			

Many more comments were made by less than three people each. Comments were very constructive and will aid a great deal in developing next year's symposium.

As you can see, the most frequent suggestion was that, although advertised as an international symposium, all of the speakers were from the United States and Canada. We had no idea that 25 countries would be represented or that over 50% of the attendees would be from beyond our shores. We have corrected the error and next year's panels all have speakers from other countries.

Another surprise to me was the numerous requests that speakers be more pragmatic with how-to-do-it information and less theory.

The respondents also asked for more and smaller sessions and a better opportunity to mingle and talk with other attendees. They wanted more participation by management and the cockpit also. All of these suggestions will be integrated in the second symposium which will be held in Palm Springs, California in February.

In 1985, three of the 26 speakers are flight attendant union representatives, three represent the cockpit, four are from the federal government, five from management and the remainder, specialists largely from private companies and institutions. Representatives from non-U.S. carriers are on each panel. We have a good balance.

Here is the agenda for the 1985 symposium:

### SECOND ANNUAL INT'L AIRCRAFT CABIN SAFETY SYMPOSIUM

A Training Program for Flight Crews

12-14 February 1985

Keynote Speaker: The Honorable Donald D. Engen,  
Administrator, Federal Aviation Administration

#### Plenary Sessions

- I. Cabin, Cockpit and Management Coordination
- II. Survivability
- III. Training
- IV. Terrorism

## 1985 AGENDA (Continued)

### Topical Sessions

Legal Aspects of Crashes

Decision Making for Safe Evacuation

Personal Health of Flight Attendants

Communications: Passengers-Flight Attendants

Safety Related Aspects of Cabin Design

Leadership in Emergencies

Emergency Procedure and Equipment Standardization

Instituting Regulatory Change in Cabin Safety

Emergency Training for Commuter/Corporate Aircraft

As you can see, a different format will be used to meet the demand. Plenary sessions will be conducted in the morning of all three days and in the afternoon of the third day. Topical sessions are available during the afternoons of the first and second days. In this way we can offer more subjects and in special areas of concern such as Emergency Training for Commuter/Corporate Aircraft.

The Institute of Safety and Systems Management at USC is grateful to the many speakers from all areas willing to share their expertise and to help all of us in making flying safer. We strongly believe that through well planned and executed gatherings such as this and the USC symposium, we will make greater strides toward fulfillment of that objective.



**Denise Noe**  
**International Organization of Flight Attendants Management**

Denise Noe was born and educated in England, attended school in Hertfordshire, immigrated to America in 1967. She flew as an Eastern Airlines flight attendant for one and one half years out of Miami, became an initial training school instructor for four years and a recurrent instructor for one year. She was promoted to specialist of training program development in 1975, and became manager of training in 1977. She returned to flying for two years while completing her Bachelor of Science Degree in Aviation Management and came back into management in 1979 as Manager of Line Training and Procedures.

She is an active member of American Society of Training and Development and a member of the International Organization of Flight Attendants Management, and is here today to represent the Inter-Airline Training Conference.

# THE INTER-AIRLINE TRAINING CONFERENCE

Denise Noe

Good Morning.

It is my pleasure to have the opportunity to address this conference and workshop on cabin safety, and to represent the many national and international air carriers which have made the Inter-Airline Training Conference such a success over the last decade.

The first formal conference, attended by representatives from training departments of 17 carriers, was hosted in Minneapolis in 1974 by Republic and Braniff. Since then, the conference has been held every Fall, and has been hosted by a different major carrier each year. Our most recent conference, as you can see here, was hosted this last September by Air Canada in Montreal, and had over 60 attendees from 40 airlines in attendance.

We feel the growth in participation at the Inter-Airline Training Conference is indicative of airline management's concern for enhanced cabin safety, and an active willingness to discuss pertinent safety issues in an open forum. Many of the topics which will be discussed here during the group meetings are topics which have been addressed during similar working meetings at our conference.

Let me spend a few moments reviewing the basic reasons for convening this conference annually.

First and foremost, the IATC is a vehicle to promote cabin safety through inter-airline communication. Despite a time of intense airline competition, a time during which how many grapes placed on a fruit plate could be considered a top corporate secret, those of us involved in cabin training and safety openly and willingly exchange knowledge and new ideas. It is important to note that this exchange goes well beyond the conference itself. Those of us involved in training and safety have formed a valuable network. The result of the network is that throughout the year I feel totally comfortable contacting my counterpart at another airline about a training or safety concern, and I know the feeling is mutual.

The second major purpose of the conferences is to present and discuss training topics of common interest and compare how topics are addressed at different airlines.

Last September, for instance, a presentation was made on a teaching method for handling medical emergencies. The concept of first responder was introduced as a simple way of instructing non-medical personnel on how to confidently access and treat symptoms, while sustaining life.

Several skyjacking training techniques were presented ranging from a dramatic one-hour videotape production to an actual simulated terrorist takeover. Another vital issue, crew coordination, was the focal point of brainstorming sessions devoted to improved communications between flight deck and cabin crewmembers. Effectiveness of passenger briefings also caused much discussion.

As a result of these sharing sessions, many of the airlines willingly allow representatives from other carriers to visit their actual training facilities to see first hand how teaching methods impact crewmember learning and class participation.

A third purpose of the IATC is to improve the knowledge of all IATC participants by inviting distinguished guests, from throughout the cabin safety and training field, to address the conference. Over the last two years, we have had speakers from the F.B.I. and F.A.A. discuss skyjacking management; a speaker from the N.T.S.B. discuss survival factor investigation, and a representative from the Canadian Ministry of Transportation address regulatory issues common to all North American carriers. We also typically have in attendance additional guests from the F.A.A. as well as the A.T.A. to bring us up to date on the status of research and rulemaking.

Finally, the Inter-Airline Training Conference is an opportunity for new training materials to be introduced.

I would like to take about five minutes to show you a videotape comprised of brief excerpts from many training videos shown and exchanged at past conferences. What you will see is a composite of tapes that we in the industry have shared over the last few years. Because it is a composite of different tapes from various airlines, it moves very quickly in an effort to highlight the many subjects we have covered. It includes accidents and incidents, firefighting, ditching, first aid, and crew communication.

Many airlines are equipped with their own facilities which allow them to produce professional training aids. One advantage of the IATC is that those carriers who do not have these facilities are afforded the opportunity to obtain these types of programs.

Of course, videotapes are by no means the only training materials or techniques discussed and shared, others range from use of specific emergency equipment, such as enhancing training by the use of door training devices, to roleplay simulations such as briefing passengers for a planned evacuation.

As we look toward the future, I anticipate the Inter-Airline Training Conference will continue to grow in participation and continue to facilitate the flow of cabin safety information throughout the airline industry. Through conferences such as the I.A.T.C., and the establishment of a cooperative network throughout the year, airlines are able to expand their knowledge about training and thus better prepare crewmembers to handle their safety-related duties.

Thank you.

## **SESSION III INFLIGHT OCCUPANT PROTECTION**

**Panel Moderator**

**Peterlyn Thomas**

**Safety Coordinator of Flight Attendants,  
Ansett Airlines of Australia**

Ms. Thomas began with Ansett Airlines of Australia in 1968. In 1974 she established a Safety Committee within the Airline Hostesses Association and held the position of Federal Safety Coordinator from that time until 1983.

She attended safety training courses and the Crash Survival Investigators School in the U.S.

She has addressed and chaired safety seminars sponsored by Flight Attendant Associations locally and internationally and was a Session Chairman at the 36th Flight Safety Seminar in Brazil.

She presently holds the position of Flight Attendant Safety Coordinator for Ansett and still functions as an Inflight Purser.



**Nora C. Marshall**  
**Transportation Safety Specialist**  
**National Transportation Safety Board**

Ms. Marshall joined the Safety Board in June 1984 as a Transportation Safety Specialist. Prior to joining the Safety Board, she was employed by World Airways for 16 years. She was qualified as a Flight Attendant on 707, 727, DC-8, DC-10, and 747 aircraft and she served as Flight Attendant Instructor for the DC-8, DC-10, and 747. She was elected to serve on her union's Executive Council and served as the Council's Safety Committee Chairperson for two years. Ms. Marshall is a graduate of the University of California, Santa Barbara and holds a Bachelor of Arts Degree in Anthropology.

# OCCUPANT INJURIES ABOARD AIR CARRIER AIRCRAFT AS A RESULT OF TURBULENCE

Nora C. Marshall

On November 24, 1983, an Air Canada L-1011 encountered severe turbulence off the coast near Charleston, South Carolina. There were four serious and 20 minor injuries. The seatbelt sign was on and the captain had announced over the P.A. that they were expecting to encounter turbulence. He instructed everyone to remain seated with their seatbelts fastened. When the aircraft encountered the severe turbulence, loose articles flew about the cabin and three passenger service carts hit the ceiling (including one that a flight attendant had thought she had just secured to the floor) and then turned over when they struck the floor. One flight attendant was injured when she was struck by one of these carts. Three cabin crew members who were not seated and belted were thrown into the air; one incurred a serious back injury. The NTSB found problems with the locking mechanism of the passenger service carts to the floor anchor pins on Air Canada's L-1011. Therefore, the NTSB suggested to the Canadian Aviation Safety Board that it recommend to the Canadian Air Transportation Administration to require Air Canada to initiate an inspection program of the passenger service carts locking mechanisms until a positive lock indication is installed or a different means of positioning and anchoring of carts is designed and incorporated. The NTSB also made a recommendation to the National Weather Service regarding forecasting of high altitude clear air turbulence and notification of pilots when it is reported or expected.

Turbulence, or an irregular motion of the atmosphere, is a common occurrence in air carrier operations. Turbulence may be caused by thunderstorm activity, or may be a result of clear air turbulence (CAT). The intensity of the turbulence is described in the *Airmans Information Manual* as light, moderate, severe, or extreme<sup>3</sup>. Since accurate forecasting of turbulence remains a somewhat inexact science, we continue to experience occupant injuries as a result of turbulence.

This paper will review NTSB and FAA accident/incident investigations of turbulence injuries, special studies, NTSB recommendations, and regulatory changes.

Problems with compiling data on all injuries related to turbulence were described in an NTSB Special Study in 1973<sup>1</sup> and a Civil Aeromedical Institute study of flight attendant injuries published in 1982.<sup>2</sup> The problems described in these two reports indicate that not all injuries are reported and therefore do not become part of the NTSB or FAA data base. Comparing the statistics that I used for this paper with injuries reported to just one airline's flight attendant association indicated significant differences in the number of injuries. The statistics and information used should be considered significant only as indicating trends.

On November 4, 1970, a Pan American World Airways 747 took off from John F. Kennedy Airport, New York. The flight encountered moderate to severe turbulence (During moderate turbulence, "unsecured objects are dislodged and food service and walking are difficult". During severe turbulence, "unsecured objects are tossed about and food service and walking are impossible") for approximately 4 minutes 10 seconds over Nantucket, Massachusetts, and 21 passengers were injured. Six passengers and 2 flight attendants were hospitalized and the other injured passengers and flight attendant were given emergency room care and released.

During the turbulence encounter, several overhead storage bins opened, spilling their contents into the cabin and several headrests in the economy section became detached from their seat units.

The seatbelt sign was on constantly after takeoff because of light turbulence encountered during the climb. Most of the injuries were sustained by persons not secured by seatbelts. The passengers probably began moving about in the cabin because of the extended period of time the seatbelt sign remained on, with only light turbulence experienced and because no explanation from the flight deck was made as to why the seatbelt sign had not been turned off. Pan Am's policy permits flight attendants to move about the cabin at their own discretion when the seatbelt sign is on, except when specifically requested by the captain to remain seated. Several flight attendants, as well as passengers, were out of their seats when the turbulence was encountered. It was not determined if the failures of the headrests contributed to individual injuries.



As a result of the investigation of this accident, the Safety Board sent a letter to the Federal Aviation Administration (FAA) on April 28, 1971, recommending improvements and/or corrective action in the following areas: Seatbelt Discipline, Boeing 747 Overhead Bin Locking Mechanisms, Economy Seat Headrests, Narrow Aisle Stretchers, and Air Carrier Policy on Deviation of Flight. The Administrator's response on May 7, 1971, indicated that the FAA issued a bulletin emphasizing oral announcements, better surveillance, and seatbelt discipline. The FAA also requested their inspectors to review current air carrier directives and policies concerning in-flight assessments of injury in order to preclude unnecessary delays in securing necessary medical assistance.

On January 4, 1972, a National Airlines 747 operating from Miami, Florida, to Los Angeles, California, experienced a jolt of turbulence while flying at 31,000 feet near Lake Charles, Louisiana. The jolt of turbulence was described as light (During light turbulence, "unsecured objects may be displaced slightly. Food service may be conducted and little or no difficulty is encountered in walking") to moderate by crewmembers on the flight deck and by passengers in the forward sections of the passenger cabin. 38 passengers and 4 flight attendants in the aft section of the passenger cabin were injured. 4 passengers and one flight attendant were hospitalized. The other injured received emergency room care and were released.

The seatbelt sign had been on for approximately 30 minutes prior to the accident. The captain had made an announcement about seat belts and the flight attendants had also made an announcement inasmuch as passengers had not complied with the captain's request.

The flight attendants were not seated since they were completing a meal service and had not been instructed by the captain to be seated.

All of the injured were located in the aft coach sections of the aircraft. The injuries included bruises, lacerations, and fractures.

As a result of this accident, the Safety Board made recommendations to the FAA regarding the number and location of first-aid kits on board aircraft carrying more than 25 passengers. It also recommended that the required first-aid kits content be upgraded to ensure satisfactory capability for treatment of fractures and severe lacerations for extended periods of time.

The FAA amended FAR Part 121.309 and provided a more complete first-aid kit and related the number of kits carried to the seating capacity of the airplane. The Safety Board also recommended that whenever the seatbelt sign was lighted, irrespective of whether or not the flight attendants are performing passenger service duties, they shall immediately visually check seatbelts and remind the passengers to keep their belts snugly fastened. As a result of this recommendation FAR 121.571 was amended to require that after each takeoff, immediately before or immediately after turning the seatbelt sign off, an announcement shall be made that passengers should keep their seatbelts fastened while seated, even when the seatbelt sign is off.

The Safety Board published a special study in 1973 which examined in-flight safety of passengers and flight attendants aboard air carrier aircraft. The study examined non-fatal in-flight injuries of passengers and flight attendants in air carrier operations during the years 1968 through 1971. The conditions, circumstances, and pre-existing factors instrumental in creating a hazardous environment for persons aboard aircraft were examined, as well as types of injuries sustained and the treatment of such injuries. The study also examined the relationship of injuries to passenger seatbelt discipline, structure, and design of cabin furnishings, flight attendant duties, and the location in the airplane of passengers and flight attendants. Some of the conclusions reached in the 1973 Safety Study were:

- 1) Encounters with turbulence in the vicinity of thunderstorms caused more injuries than clear air turbulence (CAT).
- 2) The farther away that a person is located from the aircraft's center of gravity, the higher the potential for injury. Thus, occupants at the rear of the aircraft are at greater risk for injuries during turbulence.
- 3) Passengers sustained more minor injuries than did flight attendants in both types of turbulence encounters. Flight attendants sustained far more serious injuries as a result of these same turbulence encounters.
- 4) Flight attendants were the only crewmembers injured during turbulence encounters.

- 5) Most injuries were sustained by passengers who were in the rear of the aircraft. This was a result of fuselage acceleration and displacement in the rear cabin which caused persons to strike objects within lavatory and galley areas while they were out of their seats.
- 6) A hierarchy of risks for potential injuries to passengers and flight attendants is apparent. This hierarchy is based upon the location and the mobility of cabin occupants, passenger seat belt discipline, response of the airframe at various cabin locations, certain cabin furnishings, and the location of lavatories, galleys, and lounges.
- 7) The timely alerting of flight attendants by the cockpit crew, as well as the maintenance of close coordination between cockpit and cabin crewmembers is essential in preparing for turbulence. Frequently, flight attendants are not given warning prior to entering areas of turbulence in adequate time to prepare the passengers and to stow cabin service items.
- 8) Workload has often prevented flight attendants from monitoring passenger seatbelt discipline (an example of this was National Airlines 747 over Lake Charles, LA, on January 4, 1972, where four flight attendants were required to monitor the seatbelt discipline of 268 passengers during a meal service).
- 9) The inability of cabin attendants to maintain seatbelt discipline effectively and the capriciousness exhibited by passengers who refuse to heed warnings of anticipated turbulence are major contributory factors in in-flight passenger injury.
- 10) Flight attendants have sustained injuries while they were performing normal cabin service duties, such as preparing and serving beverages and meals.
- 11) Equipment for storing, preparing, and serving beverages and meals appears to be the most common source of injuries to flight attendants. Contents of galleys and serving carts tend to become hazardous missiles when turbulence is encountered.
- 12) First-aid training of flight attendants appears to be adequate for most minor in-flight injuries. However, certain inadequacies exist in the ability of attendants to treat serious in-flight injuries.

The recommendations resulting from this study were directed to the FAA and the Air Transport Association. The recommendations were concerned with the design of cabin interiors, seat belt signs, "Lavatory Occupied" signs, lavatory doors and methods of passenger education. (See appendix 2 for summary of recommendations and responses.)

On February 10, 1981, a United Airlines Boeing 737 enroute from Chicago, Illinois, to Newport News, Virginia, encountered moderate to severe turbulence while approaching Newport News. As the aircraft approached the airport, the captain saw clouds which had to be penetrated before landing. The captain instructed the second officer to inform the lead flight attendant that they would be encountering turbulence and "to get things squared away" and have the flight attendants take their seats. Approximately 5 to 6 minutes later, while descending from 10,000 feet to 7,000 feet, the aircraft entered the clouds and encountered moderate to severe turbulence which lasted about 2 minutes. During this time, flight attendants in the aft galley were cleaning up after passenger service and securing the galley in preparation for landing. Two of the flight attendants received serious injuries.

As a result of this accident the NTSB issued a recommendation to the FAA to review and require as necessary, modification of air carriers operations manuals to assure safe and effective coordination between cockpit and cabin crew. The operating procedures recommended by the NTSB included:

- 1) Flight crew pre-departure briefings of the senior flight attendant to include forecast turbulence-related weather conditions, scheduling of cabin services and cleanup, and securing of galleys, cabin, and passengers.
- 2) Flightcrew public address announcements to forewarn flight attendants and passengers of anticipated in-flight turbulence and to require flight attendant to cease in-flight service and to be seated with their restraints fastened when turbulence penetration is expected and the intensity is forecast to be "moderate" or greater<sup>3</sup>, or when turbulence is encountered.

On July 2, 1984, the FAA issued ACOB-No. 1-76-19, *Flight and Cabin Crewmember Coordination and Communication, and Safety Deriving Potentially Hazardous Conditions of Flight.*<sup>5</sup>

A review of the statistics of reported accidents and incidents combined from the NTSB, FAA, and CAMI from 1979 - 1983 data base indicate that flight attendants receive the higher percentage of serious injuries; 65% of the reported serious injuries were to flight attendants. Passengers receive a higher percentage of minor injuries; 68% of reported minor injuries were to passengers<sup>6</sup>. More injuries continue to occur to flight attendants and passengers in the aft sections of the aircraft. The NTSB data base, which includes information on weather conditions, seatbelt sign illumination, and seatbelt use, was examined for the period 1977 to the present to determine trends related to weather and seatbelt discipline. 35 accidents were examined. This series of reported accidents indicate that more injuries were a result of clear air turbulence (68%) than turbulence related to thunderstorms. The seatbelt sign was on in 32 of these accidents/incidents and no injuries were reported by anyone who had a seat belt snugly fastened in these 35 accidents.

The serious injuries that occurred included fractures to limbs, fractures to ribs, head injuries, back and neck injuries, facial lacerations, contusions, and unconsciousness. An injured flight attendant may be unable to perform his or her safety-related duties and therefore flight attendant injuries affect uninjured passengers.

A review of the data indicates that preventing occupant injuries continues to be a problem. At the least, we must address some of the problems that are described in the accident/incident investigations with equipment, crew coordination and seatbelt discipline.

Equipment, such as passenger service carts, used in the cabin and galleys by flight attendants must be "user friendly." This equipment must be able to be secured *quickly* and easily.

Effective crew coordination will enable flight attendants to anticipate and prepare for turbulence with as much warning as possible. A knowledge of the timing and type of cabin service being provided will enable the cockpit to understand the time required for the cabin to be secured. Passengers observe flight attendants moving about the cabin many times when the seat belt sign is on. Therefore, anytime the cockpit instructs the flight attendants to be seated because of turbulence, a P.A. announcement should be made which will also serve as a warning to passengers.

In addition, the cockpit crewmembers should be aware that the intensity of turbulence is not the same in all cabin locations.

Seatbelt useage is the area that can provide the greatest potential protection against injury during turbulence. The statistics and common sense indicate that occupants who do not have their seatbelts fastened are the most likely to be injured. However, seatbelt discipline is effected by many factors, including the length of time the sign is on and the perception of danger. When I worked as a flight attendant it was my experience that I could expect total compliance with the seatbelt sign for takeoff and landing, but I could always expect some people to disregard the seatbelt sign when it was turned on in-flight. I believe that this is a problem in the passenger education area that will not be easy to overcome.

Seatbelt discipline for flight attendants is another aspect of the problem. In the absence of instructions from the cockpit to be seated during turbulence, flight attendants must rely on their own judgment as to whether they should be seated.

I believe that improvements in these areas will lead to a decrease in occupant injuries. However, if we do not establish a means of obtaining accurate information on turbulence injuries we will continue to only be able to guess at the trends. Clearly defined reporting requirements for turbulence injuries are needed. Specific definitions of injuries that must be reported should be established so that *meaningful* statistics can be evaluated.

## References

1. National Transportation Safety Board Special Study, In-Flight Safety of Passengers and Flight Attendants Aboard Air Carrier Aircraft, NTSB Report Number AA-73-1, 1973.
2. Pollard, Donell W., Earl D. Folk, Richard Chandler: Flight Attendant Injuries: 1971-1976. FAA Office of Aviation Medicine Report Number AM-82-8, 1982.
3. Federal Aviation Administration, Turbulence Reporting Criteria Table.
4. National Transportation Safety Board Recommendations and Responses
5. Federal Aviation Administration, Air Carrier Operations Bulletin No. 1-76-19, issued August 2, 1984.
6. Federal Aviation Administration Summary of Non-Fatal Attendant and Passenger Injuries.



**E. Arnold Higgins**  
**Supervisor, Survival Research Unit**  
**Protection & Survival Laboratory**  
**F.A.A. Civil Aeromedical Institute**

Dr. Higgins earned his Ph.D. in Physiology from the University of Oklahoma in 1965.

Prior to joining the FAA Civil Aeromedical Institute in 1962, he taught in the Public School System. At CAMI he began as a Research Physiologist in the Aviation Physiology Laboratory; later became the Supervisor of the Environmental Physiology Research Unit and is presently the Supervisor of the Survival Research Unit in the Protection & Survival Laboratory.

He is a member of the Society For Experimental Biology and Medicine and the American Physiological Society. He is a Fellow of the Aerospace Medical Association.

He has been the recipient of four National Science Foundation Fellowships and one National Institute of Health Fellowship.

## PROTECTIVE BREATHING; OXYGEN MASK USE/PROBLEMS

### E. Arnold Higgins

In considering protective breathing equipment, we are concerned with three populations: (1) flight crew, (2) flight attendants, and (3) passengers. We are interested in two types of protection: (1) protection from hypoxia, and (2) protection from smoke and fumes.

Let's take a look at the incidence of depressurizations over the period 1974 through 1983. *SLIDE #1*. The source for this material is CAMI's Cabin Safety Data Bank. The drop in 1982 and 1983 is probably due to a decline in the number of reports available or not yet entered into the data base for those years, and not due to fewer depressurizations. Our definition of a significant depressurization is: (1) the cabin pressure exceeds 14,000 ft., or (2) the passenger masks are deployed, or (3) an injury results from the incident.

From the incidents reported over this 10-year period, only one fatality occurred (in May 1975). It was a passenger with a history of heart problems. There were only three serious injuries, one flight crewmember with a broken arm, one passenger with a nonfatal heart attack, and one passenger with a collapsed lung. There was a total of 66 passengers and 2 flight deck crewmembers who reported minor ear pain, and 55 passengers and 2 flight deck crewmembers who reported intense ear pain. There were also 11 passengers with serious ear damage including 8 with bleeding ears. Also there were three passengers with nose bleeds. No flight attendants reported any of these problems.

There were 17 reported cases of hypoxia. There were seven passengers and five flight attendants who suffered mild hypoxia, and there were one passenger and four flight attendants who suffered loss of consciousness. There were no flight deck crewmembers who reported symptoms of hypoxia. This may be attributed to the fact that flight deck crewmembers are probably the first to be aware that depressurization has occurred and they have ready access to quick-don masks with demand regulators.

#### SLIDE 1

### 10-YEAR HISTORY OF REPORTED DEPRESSURIZATIONS

<u>Year</u>	<u>Number of Significant Incidents</u>	<u>Number of Minor Incidents</u>	<u>Number of Undefined Incidents</u>	<u>Total Number of Incidents</u>
1974	18	24	12	54
1975	15	22	1	38
1976	17	10	6	33
1977	16	13	2	31
1978	16	17	6	39
1979	20	18	7	45
1980	19	20	5	44
1981	18	12	4	34
1982	8	8	2	18
1983	7	6	6	19
TOTAL	154	150	51	355

We feel that, in general, the oxygen masks that are supplied for all occupants are of good design and adequate function. Perhaps one consideration to keep in mind is the time available for the flight attendants to don an oxygen mask. In studies conducted at CAMI in 1976, it was determined that the level of physical activity typical of flight attendant duties reduces the time of useful consciousness (TUC) by about 40 percent. If a rapid decompression occurs and the attendant(s) are not close to their designated oxygen mask, they should don the closest spare passenger mask since only 15 to 20 seconds may be available to get the mask on without adverse effects. In fact, a policy letter from the Manager, Air Transportation Division, to all Regional Flight Standards Division Managers was issued in August of 1982 to establish this as the recommended procedure.

The continuous-flow passenger mask has proven satisfactory for cabin altitudes up to 40,000 ft. when properly used. Most of the problems with this mask appear to be associated with the lack of timely or proper donning techniques; i.e., being sure to pull the mask down to activate oxygen flow, being sure the mask covers both the nose and mouth, and tightening the straps for the best fit possible.

Now I would like to discuss protection from smoke and fumes. For all crewmembers, both flight deck and cabin, it is now possible to provide protection from smoke and fumes with the same system that is designed to provide protection from hypoxia. The Technical Standard Order, TSO-C99, that was issued June 27, 1983, defines the standards for protective breathing systems that will serve this purpose. We feel that when implementing regulations are issued that will require compliance with TSO-C99, the crews will be well protected. The TSO requires contaminant leaks of 5 percent or less for the mask, and 10 percent or less for the goggles, or 5 percent or less for a fullface mask.

Providing protection of passengers from smoke and fumes is a much more complicated problem. There are several complex questions to be answered. First, we are aware that several steps are being proposed to reduce the probability of uncontrolled in-flight fires; e.g. fire blocking material on seat cushions, automatic fire extinguishers at lavatory trash bins, installation of smoke alarms at possible ignition sites, and additional hand operated portable fire extinguishers. Considering these steps and the history of there being few in-flight noncontrollable fires, is it necessary or economically feasible to develop additional protection for passengers?

SLIDE 2

**10-YEAR HISTORY OF INCIDENTS INVOLVING  
SMOKE OR FUMES IN CABIN OR COCKPIT**

<u>Year</u>	<u>Emergency Landing Made</u>	<u>No Emergency Declared</u>	<u>Unknown Status</u>	<u>Total Number of Incidents</u>
1974	9	2	7	18
1975	11	1	4	16
1976	14	1	7	22
1977	11	8	2	21
1978	13	2	2	17
1979	19	3	2	24
1980	17	4	0	21
1981	9	7	1	17
1982	10	5	5	20
1983	17	9	4	30
TOTAL	130	42	34	206

SLIDE #2. Depicted on this slide is a 10-year history of incidents involving smoke or fumes in the cabin or cockpit. Over this period, the number of incidents averaged just over 20 per year. About 13 per year were serious enough to warrant an emergency landing. There were 24 passenger fatalities. Twenty-three were from the Air Canada accident. There was one passenger who set himself afire in a lavatory. It was determined, however, that he died from carbon monoxide and smoke inhalation, not from the burns. There were three passengers with serious injury (hospitalization), 17 passengers, 2 flight deck crewmembers, and 11 flight attendants with minor smoke inhalation injury. There were also five flight deck crewmembers who suffered eye irritation without smoke inhalation. And even though it is apparent the number of incidents of smoke or fumes in-flight is small, the number of fatalities during this 10-year period is greater than that resulting from decompressions.

Some of the questions asked concerning a device for passenger protection are: Could the continuous-flow oxygen mask be adapted to provide this protection? Or would a separate mask or other device be required? Since smoke could contain irritant gases, is it necessary to provide protection to the eyes, or is protection for the respiratory system, where fumes could be more life-threatening, adequate?

At CAMI, we have recently been evaluating a standard passenger mask with a rebreather bag added, like this one (SHOW MASK). The major advantages of this system are: (1) it is a single system for protection from both hypoxia and fumes; therefore, it would require only one stowage site and one set of donning instructions, and (2) it would be relatively inexpensive (around \$5.00) to retrofit an existing mask. The major disadvantages are: (1) it provides no protection for the eyes, (2) it would require engineering modifications for some aircraft to activate oxygen flow at normal cabin altitude pressures, and (3) though modest, it would involve some cost and some additional stowage space.

Results of tests of this device conducted to date are still inconclusive. As originally designed, the device worked quite well with the subject seated quietly at ground level with oxygen flows of about 5 L/min, Standard Temperature and Pressure, Dry (STPD), which is about 6 L/min, Body Temperature and Pressure, Saturated (BTPS). To test the device further, we imposed a workload of 50 watts to increase test subjects' respiratory minute volumes, as might be anticipated during an emergency situation. Tests were also conducted at 8,000 ft. (representative of a typical cabin pressure altitude), at 14,000 ft. and 21,500 ft. Subjects were tested at each altitude both at rest and exercising. The data for flows at rest confirmed the earlier study and demonstrated that altitude had little effect on BTPS flow requirements. Mean BTPS flows ranged from 5.29 L/min at ground level to 5.58 L/min at 21,500 ft. When subjects increased their minute volumes by exercise, the device functioned properly for only two of ten subjects, even with flows up to 11.28 L/min, BTPS.

The mask manufacturer submitted two new designs of the mask with a rebreather bag. One design, which had a reduced volume rebreather bag, did not function any better than the original design. The other design, which had the inhalation valve removed from the distal end of the rebreather bag and an improved seal to the mask provided some interesting data. *SLIDE #3*. This slide presents the minute volumes, respiratory rates, and tidal volumes for subjects when they exercised on the bicycle ergometer set at a 50 watt workload. When tidal volumes were 1.59 liters or higher, the masks did not function well. Either the buildup of carbon dioxide was unacceptable, or the rebreather bag collapsed, or a combination of these failures occurred, even when oxygen flows were increased to unacceptable levels.

SLIDE 3

**RESULTS OF STUDIES OF REDESIGNED MASK WITH REBREATHING BAG**

<u>Subject Number</u>	<u>Minute Volume with Exercise (Liters)</u>	<u>Respiratory Rate with Exercise (Breaths/Min.)</u>	<u>Tidal Volume with Exercise (Liters)</u>
2	23.6	23	1.03
4	22.0	18	1.22
5	18.5	14	1.32
7	27.5	20	1.38
1	22.8	16	1.43
<hr/>			
9	23.8	15	1.59
3	19.8	11	1.80
8	18.8	10	1.88
6	17.8	9	1.98

For those subjects above the dividing line, the redesigned mask worked well, requiring flows of only 5 to 6 Liters/min.



For those subjects below the dividing line, the redesigned mask did not work. Either the required flows were too high, the buildup of carbon dioxide was unacceptable, or the rebreather bag collapsed, or a combination of the failure criteria occurred.

*SLIDE #4.* This slide presents the flows and the pCO<sub>2</sub> values for the subjects while at rest. The upper limit for an acceptable pCO<sub>2</sub> is 15 mm Hg. Only subject #6, who had the highest tidal volume, produced an unacceptable pCO<sub>2</sub> when oxygen flows were limited to 5 L/min, BTPS. When the flow was increased to 6 L/min, BTPS, pCO<sub>2</sub> was again within acceptable limits.

*SLIDE #5.* As can be seen in this slide for pCO<sub>2</sub> values when subjects are exercising, those with the lower tidal volumes had satisfactory pCO<sub>2</sub> levels with low oxygen flows. Those with high tidal volumes had unacceptable pCO<sub>2</sub> levels with the exception of subject #6, for whom the rebreather bag collapsed before high pCO<sub>2</sub> levels were reached.

We feel that a reasonable explanation is: when tidal volumes are high, the exhalation valve into the rebreather bag is not able to handle the high volume of air and a part of the air escapes around the edges of the mask, instead of into the rebreather bag. However, during inhalation the mask has a better fit to the face and the emptying of the bag is more efficient than the filling. This has two deleterious results. First, it does not allow for enough air to enter the rebreather bag to force air out through the distal valve and thus, allows the CO<sub>2</sub> to build up. Second, with the inefficient filling, and efficient emptying of the rebreather bag, the rebreather bag will eventually collapse.

Our next step will be to improve the filling of the rebreather bag when high tidal volumes occur by increasing the diameter of the exhalation valve into the bag, or by reducing the resistance of that valve, or both. At this time, the concept is still viable, but there are still unanswered questions.

SLIDE 4

**pCO<sub>2</sub> VALUES FOR SUBJECTS WHILE USING REDESIGNED MASKS — WITHOUT EXERCISE**

Subject Number	2	4	5	7	1	9	3	8	6
Exercising Minute Volume (L/min.)	1.03	1.22	1.32	1.38	1.43	1.59	1.80	1.88	1.98
8,000 ft. Altitude									
Oxygen Flow (BTPS/STPD)	5.0/3.0	5.0/3.0	5.0/3.0	5.0/3.0	5.0/3.0	5.0/3.0	5.0/3.0	5.0/3.0	5.0/3.0
pCO <sub>2</sub> (mm Hg)	1	2	2	1	2	2	8	15	19*
14,000 ft. Altitude									
Oxygen Flow (BTPS/STPD)	5.0/2.3	5.0/2.3	5.0/2.3	5.0/2.3	5.0/2.3	5.0/2.3	5.0/2.3	5.0/2.3	6.0/2.8
pCO <sub>2</sub> (mm Hg)	1	1	1	1	1	8	8	11	8
21,500 ft. Altitude									
Oxygen Flow (BTPS/STPD)	5.0/1.6	5.0/1.6	5.0/1.6	5.0/1.6	5.0/1.6	5.0/1.6	5.0/1.6	5.0/1.6	6.0/2.4
pCO <sub>2</sub> (mm Hg)	1	1	1	1	1	6	3	2	3

\*pCO<sub>2</sub> too high, BTPS flow increased for next altitudes

SLIDE 5

**pCO<sub>2</sub> VALUES FOR SUBJECTS WHILE USING  
REDESIGNED MASKS — WITH EXERCISE**

Subject Number	2	4	5	7	1	9	3*	8*	6#
Exercising Minute Volume (L/min.)	1.03	1.22	1.32	1.38	1.43	1.59	1.80	1.88	1.98
8,000 ft. Altitude									
Oxygen Flow (BTPS/STPD)	5.0/3.0	5.0/3.0	5.0/3.0	5.0/3.0	5.0/3.0	6.0/4.2	7.0/4.8	9.0/6.0	9.0/6.0
pCO <sub>2</sub> (mm Hg)	5	2	11	3	1	11	10	11	1
14,000 ft. Altitude									
Oxygen Flow (BTPS/STPD)	6.0/2.8	5.0/2.3	5.0/2.3	5.0/2.3	5.0/2.3	6.0/2.8	8.0/3.7	9.0/4.2	10.0/5.1
pCO <sub>2</sub> (mm Hg)	2	1	5	1	4	19	20	16	1
21,500 ft. Altitude									
Oxygen Flow (BTPS/STPD)	7.0/2.3	5.0/1.6	5.0/1.6	5.0/1.6	5.0/1.6	5.0/1.6	6.0/2.0	6.0/2.0	8.0/2.4
pCO <sub>2</sub> (mm Hg)	1	4	1	1	2	8	16	23	7

\* less than 1 min recorded before pCO<sub>2</sub> reached unacceptable value or the rebreather bag collapsed.

# rebreather bag collapsed before pCO<sub>2</sub> reached unacceptable value.



**James J. Brenneman**  
**Fire Protection Engineer**  
**United Airlines**

Mr. Brenneman has been employed as Fire Protection Engineer, United Airlines, since September 1958. Prior to that time, he spent 8 years as a Field Engineer and Engineering Supervisor, primarily for a major industrial insurance pool. Since joining United, Mr. Brenneman's responsibilities have included all aspects of aviation fire safety, aircraft, aircraft maintenance, fire investigations, and the fire safety of all company ground facilities. For the past 25 years, he has served on various aviation technical committees of the National Fire Protection Association, including the Technical Committee on Aircraft Rescue and Fire Fighting — serving as Chairman of this group from 1967 to 1982. He presently serves as Chairman of the Aviation Correlating Committee. Mr. Brenneman served as Co-Director of the Joint UAL, ALPA, NASA Cleveland Aircraft Fire Tests in 1966 and 1968 which developed much information on fire behavior in aircraft cabins including heat and toxic gas generation. Mr. Brenneman has received major honors from United, ALPA, and the Flight Safety Foundation and numerous other awards. He served as Chairman of the NFPA sponsored International Seminar on Aircraft Rescue and Fire Fighting, Geneva, Switzerland in 1976, which covered a broad spectrum of aircraft fire situations. He has authored several papers on Aviation Fire Safety, including the section on Aviation in the NFPA Fire Protection Handbook. Mr. Brenneman has served as consultant, principal investigator, or as a member of the investigation team in over 30 commercial and general aviation fire incidents.

# SMOKE DETECTION AND CONTROL, INTERIOR SYSTEM DESIGN, FIRE PROOFING, OCCUPANT PROTECTION, CABIN EQUIPMENT AND USE

James J. Brenneman

In *any* aircraft fire, control, containment, and/or extinguishment has a direct impact on occupant injury or survival. Since this seminar and session is primarily devoted to cabin safety, this paper will be limited to that area.

Ever since the DC-9 accident at Greater Cincinnati Airport there has been great emphasis by the regulatory authorities, the Congress, the media, and the fire community on greater cabin fire safeguards. However, cabin fires in flight are not a new problem — an inflight cabin fire of undetermined origin resulted in an unsurvivable ground impact of a Viscount in the mid '60's'. Similar incidents are documented throughout the history of flight — others may also have occurred but were not recognized as such due to the investigative procedures and techniques available at the time.

Statistically, catastrophic inflight cabin fires are fortunately infrequent; however, exposure of cabin interior furnishings to the post crash fire scenario with resultant injuries and fatalities has long been recognized. Both situations are parallel in many respects — ignition resistance and flammability of cabin furnishings, heat, smoke, and toxic gas generation, geometry of the fuel bed, that is the arrangement of combustible materials within the cabin, not necessarily aircraft fuel, etc. Again, eliminating the post crash fire scenario, I would like to share some inflight cockpit/cabin smoke, fire or fume reports available to me. The period of this study is 1980 through September 1984.

During this period, on one airline, a total of 427 reports were filed, 114 for the cockpit, 313 for the cabin. During this same period, this airline flew over 2,000,000 flight segments.

The study of fire, smoke or fume reports for the cockpit revealed 3 incidents of actual flaming, 79 electrical problems of malfunctioning switches, overheated transformers or ballasts, etc., and 32 incidents were eliminated as not applicable to the fire problem, primarily fume ingestion from outside sources. In no case was a fire extinguisher used.

Cabin incidents, as to be expected, cover a much broader spectrum. Of the 313 reports reviewed, 56 were eliminated as non-applicable for the same reasons as the similar cockpit reports. There were 61 incidents of active flaming or smouldering combustion observed. These can be broken down as follows:

- 17 — Ovens and galley equipment
- 20 — Passenger cigarettes on seats
- 13 — Waste bin — either lavatory or galley
- 4 — Electrical malfunctions
- 2 — Passenger carry-on bags
- 2 — Matches (Passenger or cabin supply)
- 1 — Malfunctioning oxygen generator
- 1 — Cigarette in lavatory supplies (suspected incendiarism)
- 1 — Passenger seats (insufficient data — caus unknown)

The remaining 196 incidents were overwhelmingly overheated lighting ballasts — the smoke dissipating shortly after the circuit breakers were pulled with no expansion of damage from the original source.

From these figures, as rough as they are, we can construct a pyramid — the broad base of incidents that are inconsequential and are easily handled by the system or procedures, a smaller number of a more serious nature requiring positive aggressive action on the part of the crew, on up to the apex — the catastrophe.

This is over simplification; however, it is the primary reason for the deep concern over occupant protection in inflight fire situations.

## Smoke Detection

Early detection of smoke is essential for early response to a potential fire situation. In all of the previously reported incidents the human nose was the smoke detector. It will remain the most effective detector since it is far more sensitive than any device presently used for this purpose. Coupled with the brain, it can also think and discriminate between friendly and unfriendly odors.

There has recently been considerable activity for the installation of smoke detectors in galleys and lavatories. I cannot disagree with the intent; however, I do have serious reservations as to the equipment proposed for this purpose — in most cases a battery operated home type product of combustion detector.

Units of this type were never intended, designed, tested, or certified for aircraft use. They can be super sensitive in small areas such as lavatories, leading to many unwanted actuations. They are also prone to actuate on changing airflows. This can lead to complacency on the part of the crew. They are also easily disarmed by the passenger who is *determined* to smoke in the lavatory, simply by removing the battery and replacing it (maybe) when finished.

It must be admitted that it may serve as a deterrent to lavatory smoking, as it has been shown that cigarette caused trash bin fires are high on the list of cabin fire reports.

What bothers me most is they can create a false sense of security as they will be very slow to react to a fire in a concealed lavatory space — for example beneath the toilet shroud.

I would sincerely hope these devices are an interim measure until more effective procedures or devices can be studied.

## Smoke Control

Control of smoke and toxic products of combustion is of serious concern in an inflight fire situation. The objective of effective smoke control is to remove it from the cabin environment without causing excessive forced draft effect on any fire. This is a manumetal task; however, I understand that the FAA has awarded a study contract as well as performing in-house work.

*Effective* smoke control could conceivably be the largest single advance for occupant survivability of any of the ideas now under study.

Obviously, uncontrolled smoke interferes with the crews' control of the aircraft, fire extinguishing efforts, and reduces passenger survival possibilities. By effectively removing smoke and toxic gases from the cabin, all three items are significantly enhanced. In the event of an uncontrollable fire, removal of the smoke also enhances the possibilities of a successful emergency landing or ditching.

There are at least two methods in which smoke/toxic gas removal can be accomplished. One — Procedures, and Two — Smoke removal hardware.

A brief discussion of each is in order:

1. **Procedures** — At least at the moment, procedures utilizing existing ventilation systems seems the least promising. Most aircraft today introduce cool air at the upper portion of the cabin and remove it near the floor level. In some cases, a portion of the air may be recirculated. Unfortunately, this is the opposite direction smoke wants to flow and has the added disadvantage of pushing smoke into the occupants breathing zone.

Other procedures have been proposed, or are in print, requiring the cracking open of doors in flight. This has an inherent danger to the crew members and in some cases converts a controllable fire into an uncontrollable one through the forced draft effect. Personally, I do not consider this a viable procedure.

2. **Hardware** — Modification of existing hardware or the development of new equipment seems to offer the most viable means of *effective* smoke control and removal. Not being an aeronautical engineer and with the limited time available, I cannot go into details; however, here are two of my own ideas which

may have a little merit:

- A. Close the cabin outflow valves and install venturi type devices on the upper portion of the fuselage. Conditioned air would then flow upwards and overboard. Smoke generated at or near the floor would be carried into the ventilation zone and overboard.
- B. Devise a means to reverse the normal ventilation system — that is introduce fresh air at or near the floor, exhausting through the normal air input ducting.

I am sure there are many other ways, however the concept is to introduce fresh air at some point between the floor line and the occupant breathing zone and remove smoke, etc. near the top of the cabin. Any ducting employed in smoke removal would, of necessity, need to be fire hardened and resistant to high temperatures.

One last point on this subject, an artificial fire smoke may need to be created to test such a system. Smoke candles, smoke bombs, theatrical smoke, etc. do not have the same physical characteristics as fire smoke as far as temperature, buoyancy, etc. are concerned.

## Interior Systems Design

From a fire viewpoint, two of the most serious problems facing us today are unrestricted concealed spaces between the cabin interior panels and the aircraft structure, and adequate methods of testing candidate materials which reflect the geometry of installation.

Concealed spaces, whether in an aircraft or in a building, are a fire fighters and fire protection engineers' nightmare. Access is usually limited, the geometry of the combustible material is ideal for re-radiation of heat to quickly intensify any fire, and fires can exist for considerable periods of time, sometimes hours, before breaking out into the open where they are discovered. I personally know of two cases where this occurred, one on an aircraft was about 45 minutes, the other in a building approximately 5 hours.

The two accepted methods of protecting against fire in concealed space are passive and active.

In the passive mode, the space is subdivided by partitions or flame barriers. This method limits the combustibles available, limits flame spread and enhances the probability of early detection.

In the active mode, an automatic fire suppression system is installed in the space using an appropriate extinguishing media.

For buildings, both methods are often simultaneously employed; however, I do not feel this would be practical on an aircraft from a weight and cost standpoint.

The FAA has embarked on a program of fire hardening of aircraft interior panels, at least according to the information available to me at this time. The space *behind* the panels should be included in this program.

The other item I mentioned was testing methods which represent the geometry of installation. The geometry of the fuel bed — that is the combustible material — is critical to fire growth and behavior. Few present and proposed test methods, in my opinion, take this vital item into adequate consideration.

Present laboratory test methods measure, to a degree, the ignition resistance of a candidate material, usually in a vertical plane. A material may exhibit acceptable char length and self-extinguishing properties, the same material may burn freely on the test bench when another material of the same or different composition is brought into close proximity to the test surface due to re-radiation. Even the radiant panel test has severe limitations as opposed to real time conditions.

As an example of this geometry effect, try to burn just one oak log, once the kindling is gone the log gradually self extinguishes — however, two or three logs in close proximity burn readily.

Even with the limited ignition resistance of cabin materials available today, success cannot be overlooked. This is witnessed by the previously mentioned 279 incidents of electrical malfunction which did not progress beyond the point of ignition. It is when the ignition source exceeds the ability to resist, and the geometry of the combustible is conducive to fire growth that catastrophe occurs.

Even wire bundles are not exempt — a single overheated wire may burn itself 'open' before the fire spreads, while wires in close proximity may go to active flaming due to the overheating of a single wire in the group.

I have purposely avoided discussing the fire blocking of seat cushions. This is an admirable and needed forward step; however, it does little to reduce the probability of a severe cabin fire except in cases of incendiaryism or the post crash fire mode.

## Individual Occupant Protection

As a result of the Cincinnatti accident, several proposals have been made for individual occupant protection which include, but are not limited to modification of the existing oxygen masks, a hood with air supplied by the gasper system, and a filter type hood. All have serious disadvantages which must be carefully considered prior to adoption. Briefly, I would like to talk about each individually:

1. Modified Oxygen Mask.
  - A. this mask was never designed or intended as a smoke mask — even fitted with a re-breather bag, a negative pressure must be developed inside the mask to utilize the contents of the re-breather. A *tight* seal to the face is therefore extremely important. Certain toxic gases generated in an aircraft cabin fire are debilitating even in very low concentrations.
  - B. the oxygen lines supplying the mask need to be changed since the aluminum lines presently used can fail early in a fire in the concealed spaces negating the usefulness of the mask and possibly intensifying the fire on a local basis.
  - C. A greatly increased oxygen supply will be necessary to extend the time that the mask is needed to be used.
2. Filter Type Hood.
  - A. Carbon monoxide is by volume, the largest component of the toxic gases generated in an aircraft fire. In the hoods of this type that I am familiar with, this gas rather quickly breaks through the filter media. This gas is colorless and odorless. The user has no warning that the filter is no longer effective. The hood is absolutely worthless in an oxygen deficient atmosphere. Fire services have long ago discarded cannister (filter) type masks as too dangerous to use in their operations.
3. Gasper Supplied Hood.
  - A. Again we have the vulnerability of the supply of air to the hood. Ducting is of lightweight construction and can fail early in the fire. Fans supplying the gasper system are vulnerable to interruption of the electrical power supply.
  - B. Some aircraft are not equipped with a gasper system, while in others the gasper outlets are not in easy reach of a seated occupant.
  - C. A connection must be made by the user to an eyeball socket and the socket *opened*. In an emergency situation, this may not be easily accomplished and the *opening* of the socket for air supply easily forgotten by a person unfamiliar with the operation.

Whether it be mask or hood, devices of this type can interfere with rapid evacuation of the aircraft.

While not totally opposed to individual occupant protection, the point to be made is that if this type of equipment *must* be supplied, we should be assured that what is done is *truly viable* and a thorough fault tree analysis is done on the system chosen.

Cabin crew members should be provided with a self-contained individual breathing system as they are the primary fire fighters and must set-up and direct evacuation.

Briefly, another item that has been suggested is smoke/fire containment curtains to subdivide the cabin. While seemingly simple, they too have serious shortcomings. Unless a corresponding barrier is placed in the concealed space, fire and smoke will easily by-pass the curtain. A totally non-combustible section must be in

place fore and aft of the curtain where it joins the cabin walls — again to prevent by-passing. It has also been shown in the past that cabin subdivision with equipment of this type can be detrimental to evacuation time.

## Cabin Fire Equipment

At present, there are four major extinguishing agents in use on aircraft.

1. Water
2. Dry Chemical
3. Carbon dioxide
4. Halon 1211 and mixtures of Halon 1211 and 1301

Objectively looking at each individual agent and its containing hardware as presently used on aircraft, we can find certain shortcomings in each.

1. **Water** — The best all round extinguishing agent known to man. It has high heat absorbing capabilities and will generate a certain amount of steam for smothering action which aids in quick flame knockdown. The basic disadvantage in an aircraft cabin is water's electrical conductivity which can be a shock hazard to the operator and also result in secondary shorting and damage to electrical equipment.

The primary problem with water extinguishers as used on aircraft today is the packaging hardware — the extinguisher itself. Water is discharged in a fine pencil point stream which makes minimal use of the excellent cooling properties of the water and requires exceptional skill on the part of the operator. Present extinguishers are clumsy and difficult to use effectively in confined spaces or for underseat fires.

2. **Dry Chemical** — An excellent agent in its place but not aboard an aircraft. Visibility is quickly lost due to the large cloud of opaque powder. While not conductive, secondary damage to un-involved electrical equipment can result due to the non-conductive qualities of the chemical. The most commonly used dry chemical on aircraft today, potassium bicarbonate (Purple — K) is ineffective on burning solid materials where a deep seated fire can be expected. As a final note on dry chemical, one major manufacturer refuses to sell its equipment if it is known that it is to be used on an aircraft.
3. **Carbon Dioxide** — An excellent agent for ordinary electrical fires; however, secondary damage to delicate electronic equipment can occur due to the rapid chilling effect. It is not effective on deep seated fires in solid materials. The hardware is heavy for the amount of agent.
4. **Halon 1211 or mixtures** — This is the best agent available today for aircraft use. It is effective on burning solids, liquids, and safe for use on all electrical equipment. A word on the burning solids — most if not all — Halon extinguishers carried on aircraft today do not carry a Class A rating (burning solids) by a recognized testing laboratory. This is not due to lack of agent capability — only due to lack of quantity that will extinguish the rating test fires.

Halon is not without some drawbacks. Toxicity of the neat agent is low and in the quantities carried are well within allowable limits even if all units carried were discharged simultaneously within the cabin. Tests by the FAA Technical Center and our own tests in an unventilated 737 cockpit confirm this statement.

Toxicity of the agent when decomposed in a fire can be a problem if the extinguisher is improperly used. Toxic products such as hydrogen fluoride, hydrogen bromide, hydrogen chloride, and some carbonyl halides are formed during decomposition. Fortunately all of these materials have an extremely acrid odor and become unbearable well below the toxic levels — similar to household ammonia.

I know of two cases where toxicity might have been a problem — in both cases the extinguishers were used in short bursts without ever determining the fire was completely out between bursts. This 'squirt and peek' technique is poor practice with Halon as well as any other extinguisher. The *entire contents* of the unit should be used in a *continuous* application or until it is absolutely certain that the fire is out. This technique reduces to a minimum the agent decomposition. The area should be ventilated as soon as



possible after use.

Since Halons have limited heat absorptive capabilities, rekindling may occur in the case of a deep seated fire. Wherever possible water should be used as a follow-on agent.

Selection of Halon hardware should be given serious consideration. Most units on the market of less than 5 lbs. capacity do not have a flexible discharge device (a hose); however, there is one, possibly two units in the 2½ to 3 lb. capacity range that are so equipped, commercially available. Others may follow.

Our own testing program, consisting of well over thirty fires in a simulated aircraft environment using actual aircraft materials show that the provision of a hose increases the effectiveness of the unit by an order of magnitude, particularly in confined spaces such as underseat fires, behind panels — both decorative and instrument — and other hard to reach spots. A new "Standard for Aircraft Hand Fire Extinguishers #408" published by the National Fire Protection Association recommends the provision of a hose on Halon fire extinguishers.

Regardless of the agent or the hardware, training in the use of extinguishers is of critical importance. My own ideas of adequate training are impractical due to time and cost constraints for all crew members — remember I have been using fire extinguishers for over 30 years and do not consider myself an expert by any yardstick; however, at least the Instructors should be thoroughly familiar with the use, operation, and limitations of aircraft fire extinguishers. In a recent quick and dirty survey, only about 25% of Instructors had any training on their use or had ever used an extinguisher on a live fire. Fire fighting is not as easy as it looks in the training films.

**SESSION IV**  
**CRASH AND FIRE PROTECTION**

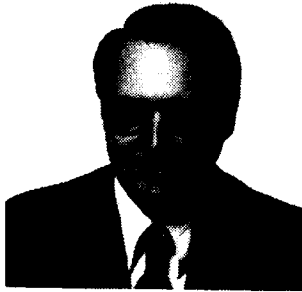

**Panel Moderator**

**Doug Clifford**

**Chief Engineer, Airworthiness and Product Assurance  
Boeing Commercial Airplane Company**

Mr. Clifford has an MSEE Degree from the University of Washington and has worked for the Boeing Company for more than 30 years in a variety of engineering design and technical staff management positions. For the last 6 years he has been designated Chief Engineer — Airworthiness and Product Assurance, and in this capacity is responsible for management of certification, safety, reliability and maintainability activities for Boeing Commercial Airplane Programs.

He is a member of the Flight Safety Foundation International Advisory Committee.



**Warren A. Stauffer**  
**Director, Engineering-Technology**  
**Lockheed California Company**

Mr. Stauffer has had 42 years experience in the design of military aircraft. He has been a consultant and advisor to NASA and the U.S.A.F., in problems regarding loads and structures problems. He is currently Chairman of the NASA Aeronautical Advisory Committee, Material and Structures Sub-Panel and is a consultant and special advisor to the U.S.A.F. Scientific Advisory Board.

In 1974, Mr. Stauffer was the recipient of the Outstanding Achievement Award — Society of Manufacturing Engineers and was the Engineer of the Year, Valley Engineering Council. In 1978, he received the AIAA Structures, Structural Dynamics, and Materials Award for Outstanding Contributions to the Development of Internationally Accepted Fatigue and Damage Tolerance Requirements for Commercial Aircraft. In 1982, Mr. Stauffer was elected a Fellow of the American Institute of Aeronautics and Astronautics.

Mr. Stauffer is presently responsible for the direction of the structures, flight sciences, and test and evaluation organizations in the engineering branch for the Lockheed-California Company.

# TRANSPORT CRASH DYNAMICS - AIRFRAME STRUCTURAL INTEGRITY, DESIGN CRITERIA

W.A. Stauffer and G. Wittlin

## ABSTRACT

The progress that has been accomplished to date with regard to the field of Impact Dynamics of transport airplanes includes the following achievements:

- A comprehensive review of transport airplane accident history.
- The formulation of candidate crash scenarios.
- Improvements in methodology for predicting large-airframe structural response during an impact.
- Full-scale instrumented section and airplane tests.

The accomplishments noted are part of an overall joint FAA/NASA Impact Dynamics Program, which includes industry participation. Many facets of the FAA/NASA program still need to be completed, however, to establish meaningful design procedures that will enhance occupant safety in a survivable accident. In particular, a wide range of impact severity parameters for candidate crash scenarios must be applied to past and current transport aircraft (with satisfactory crash survival records) to establish upper bounds of crash severity for application to new transport design configurations and new advanced materials.

## INTRODUCTION

Nearly a decade ago industry and government collaborated to map out a course of action with the goal of providing a continuing high level of occupant safety in future transport airplanes exposed to survivable accidents. As a result, the FAA and NASA jointly,<sup>1</sup> with the assistance of industry, embarked upon a program to develop a technical database and methodologies

necessary to assess the dynamic impact environment and requirements needed for occupant survivability in survivable accidents involving civil aircraft.<sup>2</sup>

There are many facets to this program including a definition of the impact environment; development of analytical methods to produce structural and occupant responses consistent with test results; acquisition of meaningful measured data from appropriate full-scale tests; and the establishment of performance parameters to ensure that a high level of occupant safety in future designs will be maintained. This is a comprehensive undertaking that should lead to improvements in design criteria if each step is carried out to its logical conclusion.

The key elements of the program are depicted in Figure 1. Several of the tasks have been completed or are in progress as noted. The results of the completed tasks have been encouraging. Significant tasks are still to be accomplished, however. An assessment of the progress to date stresses the importance of completing all aspects of the program to provide meaningful design criteria that will ensure a high level of occupant survivability in future aircraft accidents.

## ANALYSIS OF ACCIDENT DATA

In-depth studies<sup>3, 4, 5</sup> for the period 1958-1979 reveal that the overall survivability record for large transport accidents is excellent. Air carriers account for less fatalities than any of the other major travel modes. For example, air carrier fatalities were less than 0.7 percent of all transportation fatalities in 1979 (Figure 2). Since 1980 this enviable record has improved. In fact, the accident study results indicate that jet aircraft, particularly the U.S. fleet, show increasingly significant improvements over the last 20 years, as can be observed in Figure 3. So, why the concern about transport air-

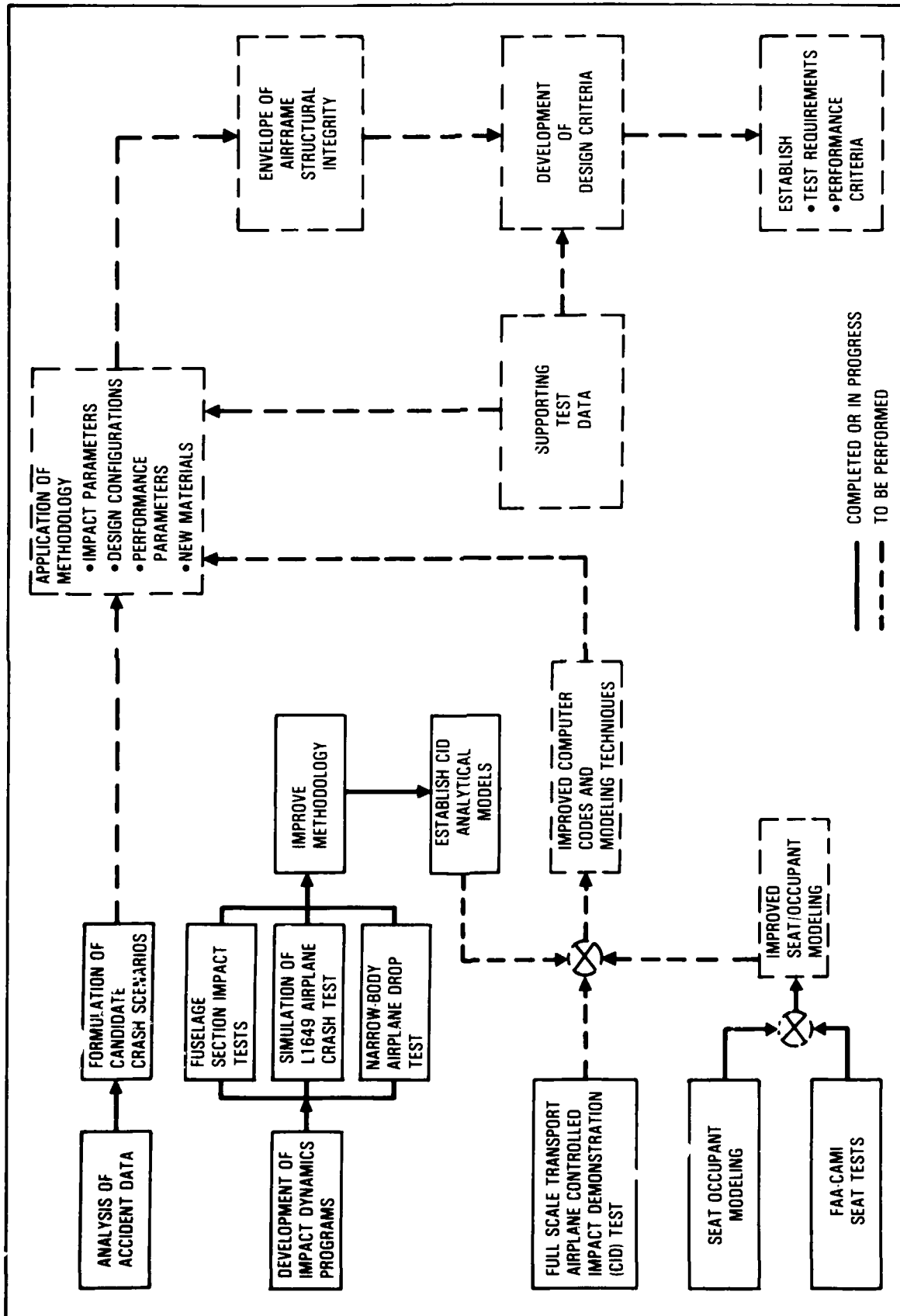

FIGURE 1. TRANSPORT AIRPLANE IMPACT DYNAMICS PROGRAM - MAJOR TASKS

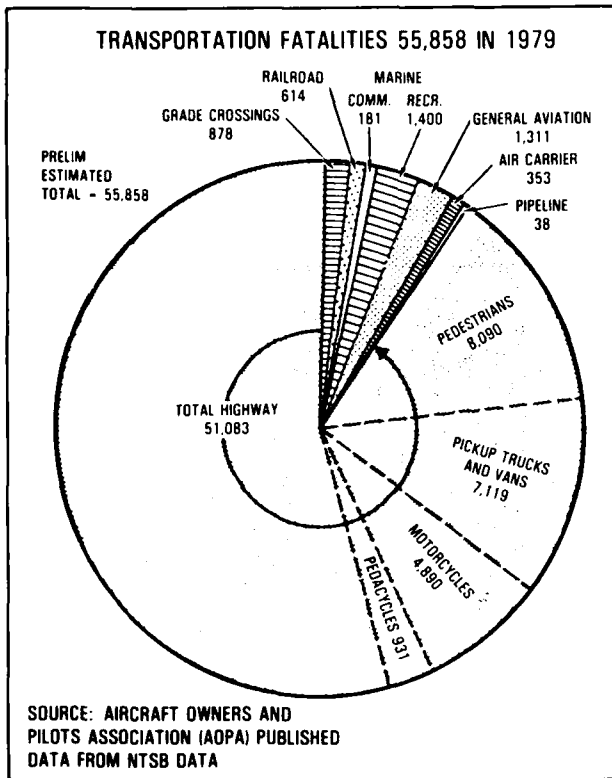

FIGURE 2. TRANSPORTATION FATALITIES, 1979

plane impact design criteria? Accidents cannot be completely eliminated; thus, passenger injuries and fatalities will continue to occur in the future. Furthermore, new transport configurations and aircraft structures using new materials may be less "forgiving" than current metal designs and thus could result in a more hazardous environment for occupants. Consequently, industry and government jointly have an obligation to take all necessary steps to ensure that safety in future advanced transport airplane survivable accidents is not degraded but, rather, improved.

The definition of the impact environment is essential before aircraft structural integrity and design criteria can be assessed. There were 176 detailed accident files reviewed by the three major domestic transport airplane manufacturers.<sup>6</sup> While no two accidents are identical, there are similarities which allow for a rational arrangement of hundreds of accidents into a few candidate crash scenarios. Accidents that happen when an airplane is on the ground and where no major hazards are involved, are rarely fatal. Conversely, when impact occurs at high speed, with a high-impact angle and hazards (as accidents away from airports often do), the accident has a high probability of fatality. Between the extremes, the outcome in terms of occu-

part survivability depends on the impact parameters and surrounding hazards. Figure 4 shows a distribution of the severity of accident versus accident type.

It is expected that occupants should be given every reasonable chance of surviving as long as the airframe

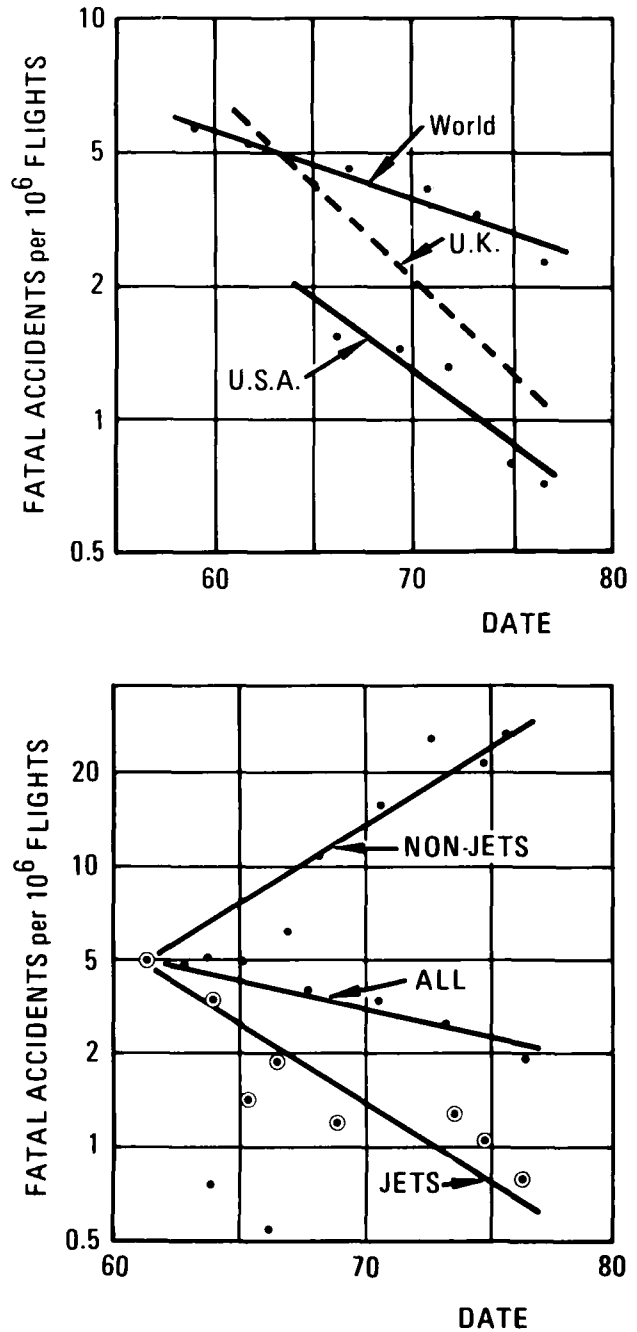

FIGURE 3. TREND OF ACCIDENTS RATES, USA VERSUS THE WORLD AND JETS VERSUS NONJETS (REFERENCE 21)

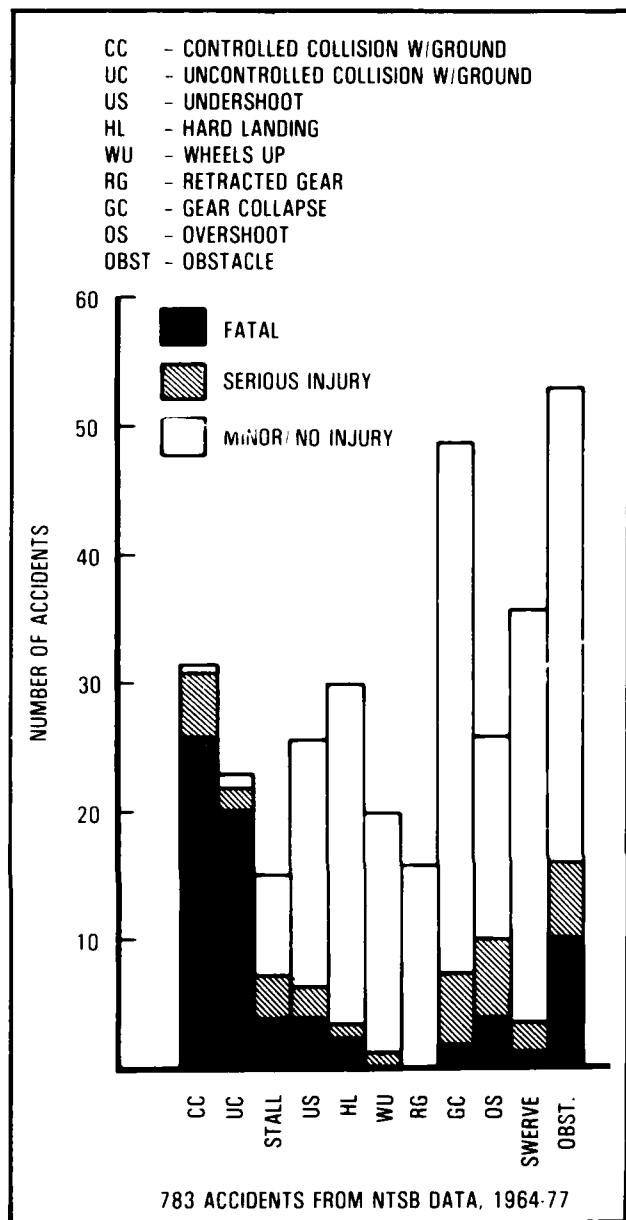

FIGURE 4. SUMMARY OF RESULTS OF ACCIDENT STUDY (REFERENCE 4)

can maintain the structural integrity of the basic shell. This level of integrity can vary depending on the size and configuration of the aircraft. Thus, the initial step in the process is to define applicable crash scenarios. In simple terms, a crash scenario is no more than a set of initial impact conditions such as forward velocity, sink speed or attitude, weight, center of gravity (c.g.), terrain, and gear position. Two of the more likely candidate crash scenarios are shown in Table 1. The actual quantitative values associated with each scenario have to be determined as part of the overall program.

## Full-Scale Impact Test Data

In 1965 full-scale crash tests were performed for two medium-sized, transport-category aircraft; a DC-7 (122,000 pounds) and an L-1649 (159,000 pounds)<sup>7,8</sup> The L-1649 test provided some meaningful measured passenger floor pulse data. Prior to these tests, the highest gross weight aircraft tested was 42,000 pounds. The 1965 tests were of the ground-to-ground overrun type. Sample measured floor pulses from the L-1649 full-scale test, for a 6-degree slope impact, are shown in Figures 5 and 6 for the longitudinal and vertical directions, respectively. These data represented the most significant available transport airplane data until the recent FAA/NASA crash dynamics program. In the last two years several section impact tests have been performed in conjunction with this program. Table 2 lists some of these tests.

All of the airframe sections noted in Table 2 were dropped vertically with an impact velocity of 20 ft/sec. Sample results of the tests are shown in Figures 7 through 10. As can be observed, the floor pulses show a wide variation in peak deceleration and response shape. The pulses and resultant damage are a function of the design (floor support, frame segment), construction (soft or hard point), and loading (occupant, cargo). In addition to the fuselage section tests a full-scale, narrow-body aircraft (196,000 pounds) was dropped in a 1-degree, nose-up attitude with an impact velocity of 17 ft/sec. The response data are not available at this time but the resultant damage has been recorded. Of interest in this full airplane test is that the most severe damage occurred at the passenger floor structure in the region between the main landing gear wheel well bulkheads and included significant rupture. The hard points between the wing center section forward bulkhead and the main landing gear rear bulkhead produce high-magnitude, short-duration pulses similar to the pulse shown in Figure 8. It is the response at the hard points that tends to produce critical loads for the airframe and occupants. All of the aforementioned tests have been or are being modeled as part of the FAA/NASA Impact Dynamics Program. The data obtained from these tests have provided a valuable opportunity to improve computer coding and methodology techniques.

## Methodology Development

During the 1970s the application of computer technology to analyze large nonlinear behavior of rotary and fixed-wing aircraft structure improved significantly under U.S. Army,<sup>13</sup> FAA,<sup>14</sup> and NASA<sup>15</sup> sponsor-

TABLE 1. IDENTIFICATION OF CANDIDATE CRASH SCENARIOS

CANDIDATE CRASH SCENARIO	IMPACT CONDITIONS	ACCIDENT TYPE	TERRAIN
GROUND-TO-GROUND, OVERRUN	LOW SINK SPEED LOW FORWARD VELOCITY SYMMETRICAL AIRPLANE ATTITUDE GEARS COLLAPSED	TAKEOFF ABORT LANDING OVERRUN	RUNWAY HARD GROUND
AIR-TO-GROUND, HARD LANDING	HIGH SINK SPEED LANDING VELOCITY SYMMETRICAL AIRPLANE ATTITUDE GEARS EXTENDED OR RETRACTED	HARD LANDING UNDERSHOOT	RUNWAY HARD GROUND

ship. A number of full-scale section and airplane impact tests were performed and the results were correlated with the analyses. During this period the idea of approximating the nonlinear behavior of large regions of structure with simplified representations, supported by test data, showed great promise. This approach is often referred to as "hybrid modeling."

The hybrid application is particularly effective for the representation of underfloor crushable structure. Some early hybrid models for light fixed and rotary wing aircraft are shown in Figures 11 and 12, respectively. Large transport airframe representations are more difficult to model than light fixed and rotary wing aircraft, due to the large size of these configurations. The problem of modeling large transport airplane structure was further heightened by the lack of test data to provide simplified representations of more complex structure. Now, however, the increased activity in full-scale testing of transport airframe structure has provided valuable data and the opportunity to improve methodology.

One of the first attempts to model transport behavior with current techniques is described in Reference 16. The L-1649 ground slope impact test, previously noted, was modeled with both an airframe and floor model. The analysis results were compared with the reported test results, for an overrun condition in which the airplane, moving forward at 172 ft/sec gears removed, impacts a 6-degree sloped earthen mound (sink speed ~ 18 ft/sec). For this particular impact condition, the soil flexibility presents a difficult parameter to model.

Figure 13 shows the trend of the responses, in relation to fuselage region. In general, agreement is better in the midcabin region than at the extremes of the fuselage. The analysis assumes some ground flexibility to represent the earthen mound. More rigid terrain (i.e., concrete) results in higher acceleration peaks. Figure 14 shows a comparison of the vertical and longitudinal accelerations at the floor in proximity to the airplane c.g. (FS685). The amplitude peaks and pulse durations compare favorably, except for the higher frequency perturbations, particularly noticeable in the vertical response. Since the airframe maintained a protective shell for the occupants and the floor structure was not disrupted for the 6-degree slope impact, the pulses obtained from this test provide an indication of floor dynamic pulses for a medium- to large- size transport aircraft.

Subsequent to this analysis, computer coding and modeling improvements were incorporated. These improvements upgrade the capability of analysis to better represent structural behavior during an impact and facilitate the assessment of modeling results.

Modeling of frame segments has helped develop the means by which large regions of structure can be represented by a simple load-deflection curve. This type of data is essential for large-transport analyses since element-by-element modeling is impractical. Sample comparisons of recent analyses and measured test results are shown in Figures 15, 16, and 17. As expected, these comparisons between analysis and test do not agree in every respect. What is important is whether or not the differences are understood; the modeling tech-



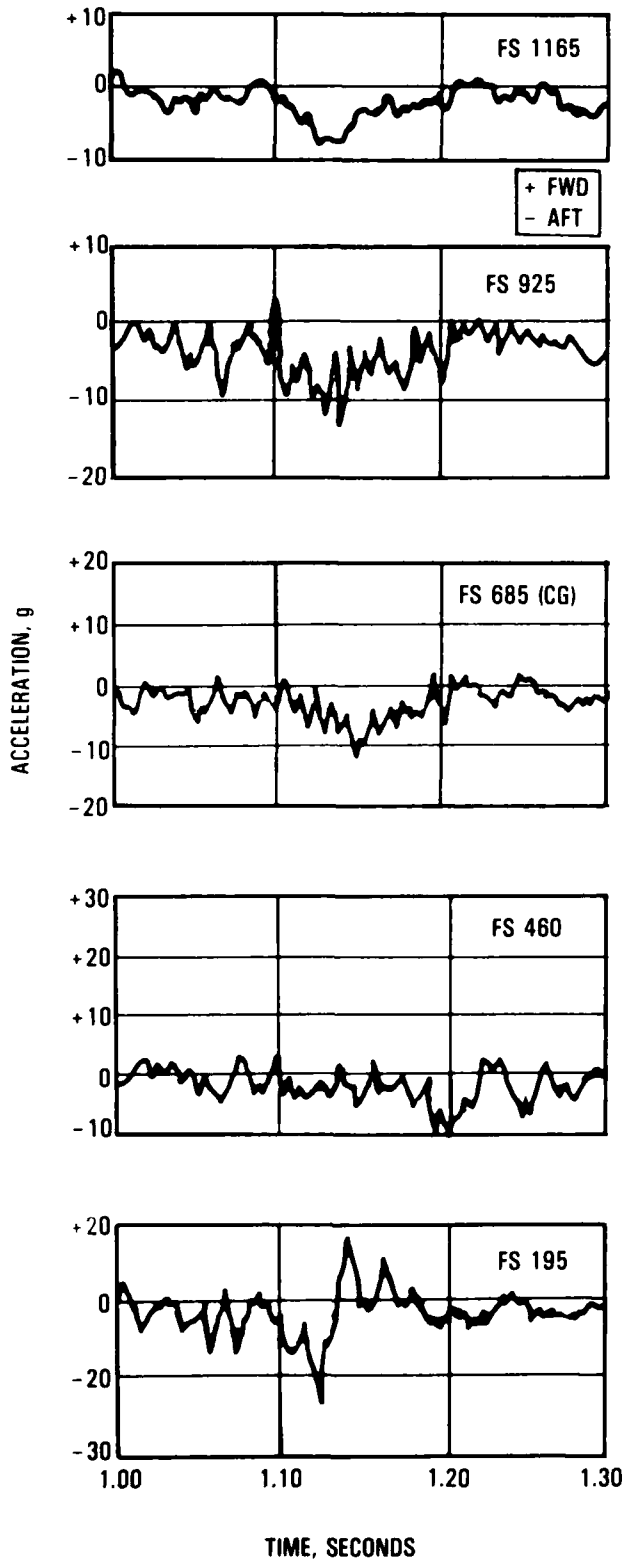

FIGURE 5. FLOOR LONGITUDINAL ACCELERATIONS, L-1649 TEST, 6-DEGREE SLOPE IMPACT (REFERENCE 8)

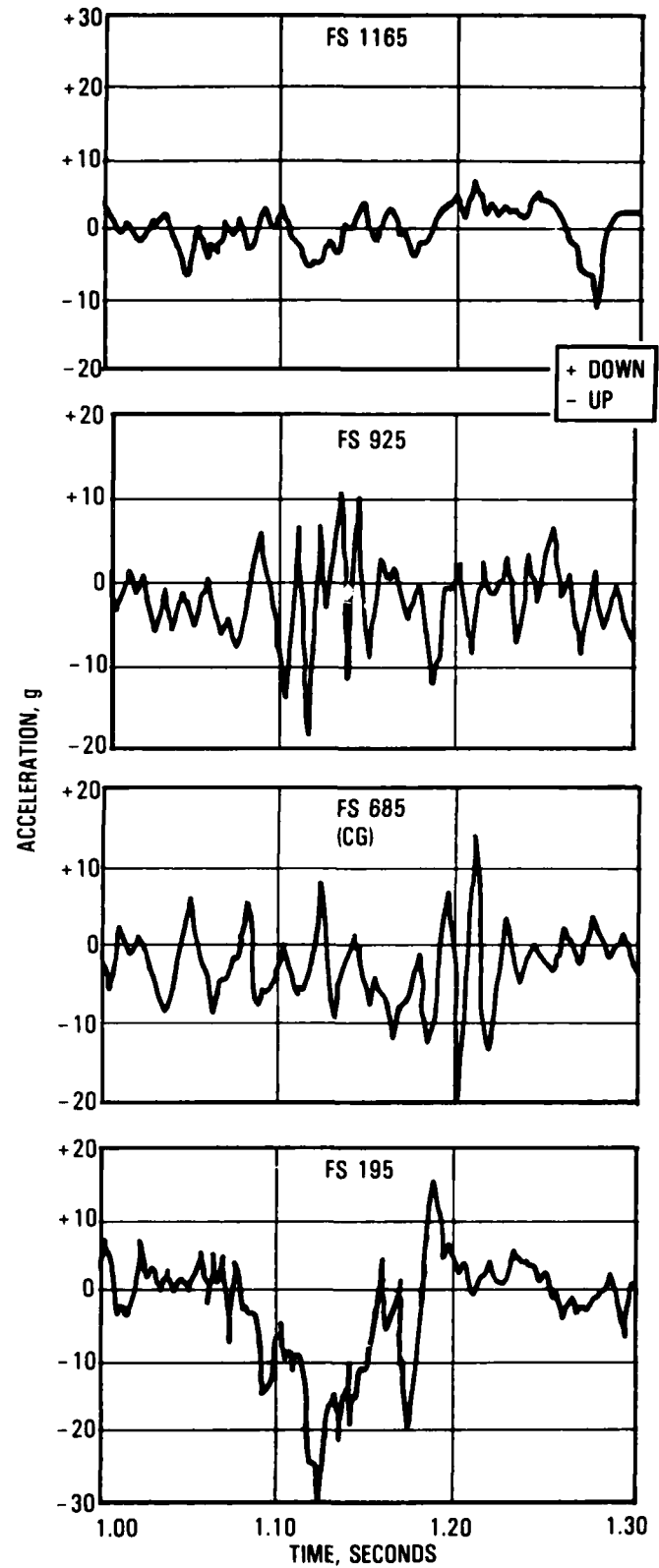
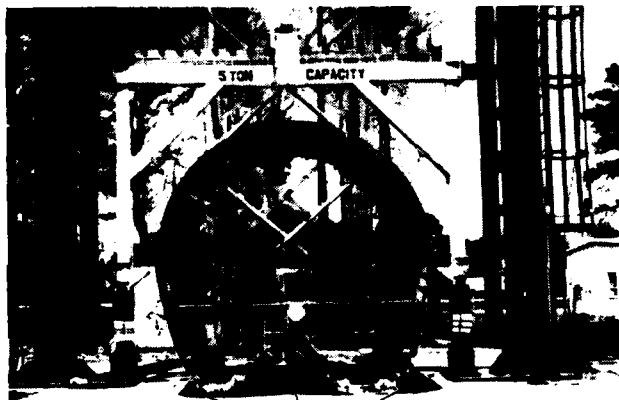

FIGURE 6. FLOOR VERTICAL ACCELERATIONS, L-1649 TEST, 6-DEGREE SLOPE IMPACT (REFERENCE 8)

TABLE 2. FAA/NASAA FULL-SCALE SECTION IMPACT TESTS

<u>STRUCTURE</u>	<u>APPROXIMATE* WEIGHT (lb)</u>	<u>AIRPLANE</u>	<u>TEST PERFORMED BY</u>
FORWARD FUSELAGE SECTION	5100	NARROW-BODY	NASA <sup>(9)</sup>
CENTER SECTION	8000	NARROW-BODY	NASA <sup>(10)</sup>
FORWARD FUSELAGE SECTION	6400	NARROW-BODY	FAA <sup>(11)</sup>
AFT FUSELAGE SECTION	5000	WIDE-BODY	FAA <sup>(12)</sup>
*SECTION, OCCUPANT AND CARGO			



POST TEST VIEW

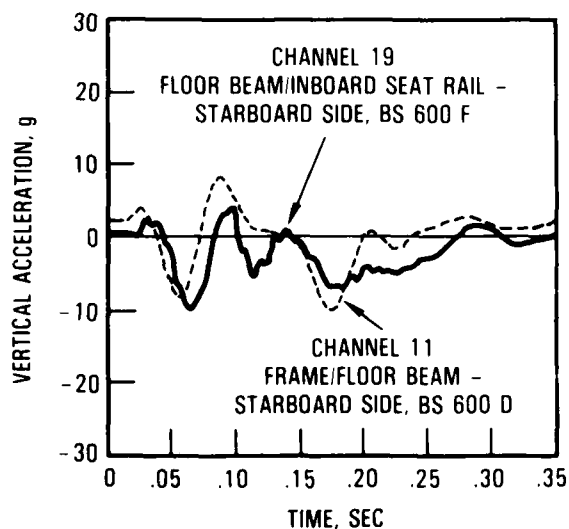

FIGURE 7. RESULTS OF NARROW-BODY AIRPLANE FUSELAGE SECTION TEST (REFERENCE 9)

niques can be improved; and the analysis can provide a simplified representation of overall behavior. For example, a major goal of frame analysis is to produce a load-deflection curve (Figure 16) for use in a much larger airframe model.

The data obtained from the section tests, as well as the data developed from the modeling of tests, are being used in current analyses [19, 20] of the Controlled Impact Demonstration (CID) test. Figure 18 shows a current model representation in which both the airframe and floor are integrated. The model shown in Figure 18 is more comprehensive than an earlier stick model (Figure 19), which provides overall airframe responses. Both models have advantages and limitations which must be explored further. The analytical results, using the CID models, will be compared with measured test data and further improvement in modeling techniques and computer coding is expected. The development of analytical procedures for determining nonlinear behavior of airframe structure for impact conditions is evolving through the continuous process of modeling, correlating, refining, and improving for known conditions.

### APPLICATION TO DESIGN CRITERIA

The CID test, which has been several years in the making, is intended to provide valuable structural response data for an impact condition. No matter how successful a full-scale test is, the results are representative of only one data point. Additional full-scale testing of the magnitude of the CID program will be extremely costly and not likely to occur in the near future. Airframe section tests provide supporting data with regard



POST TEST VIEW  
TIME HISTORY VERTICAL RESPONSE AT  
PASSENGER FLOOR

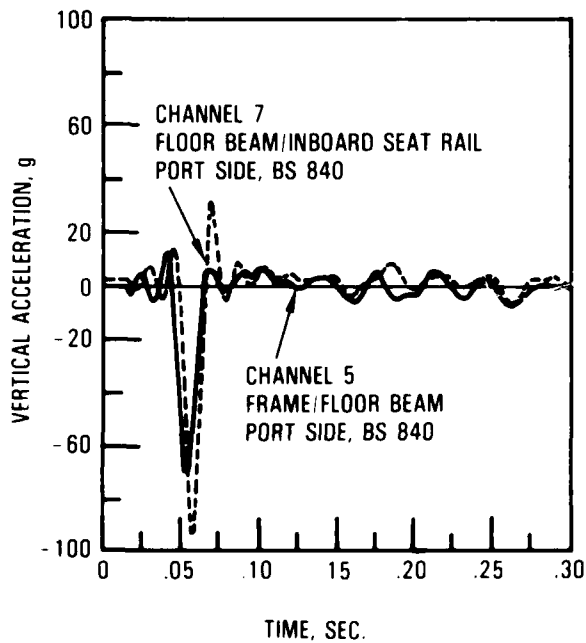

FIGURE 8. RESULTS OF NARROW-BODY AIRPLANE  
FUSELAGE CENTER SECTION TEST  
(REFERENCE 10)



POST-TEST VIEW

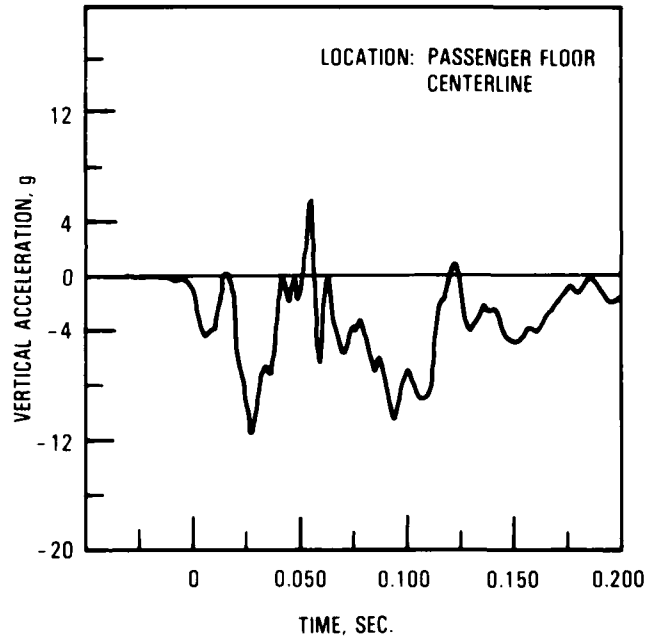
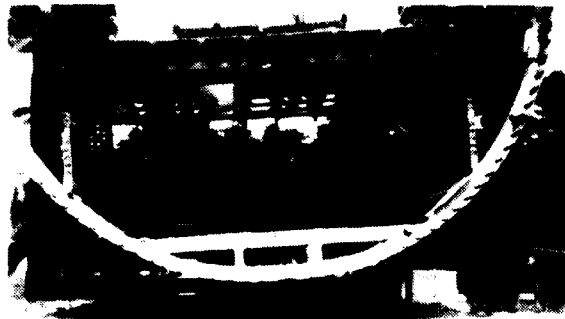

FIGURE 9. RESULTS OF NARROW-BODY AIRPLANE  
FORWARD FUSELAGE SECTION (WITH CARGO)  
TEST (REFERENCE 11)

to load-deflection behavior and energy absorption capability. The survival of occupants in an impact situation depends on how well the airframe shell structure maintains its overall integrity. Therefore, it is important to determine the limits of impact severity for candidate crash scenarios for past and current transport aircraft with satisfactory crash survival records. It is unrealistic to expect that the envelope of airframe structural integrity can be determined from a series of



OVERALL STRUCTURAL DEFORMATION



BUCKLING OF VERTICAL SUPPORT MEMBER

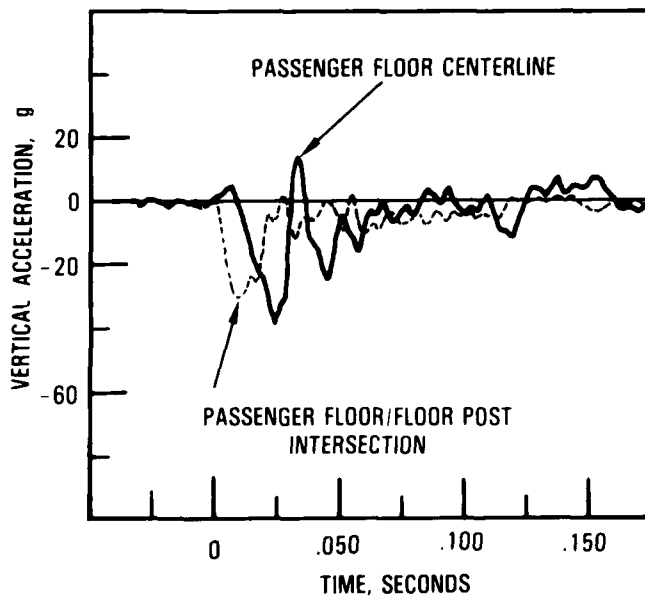

FIGURE 10. RESULTS OF WIDE-BODY AIRPLANE AFT FUSELAGE SECTION TEST (REFERENCE 12)

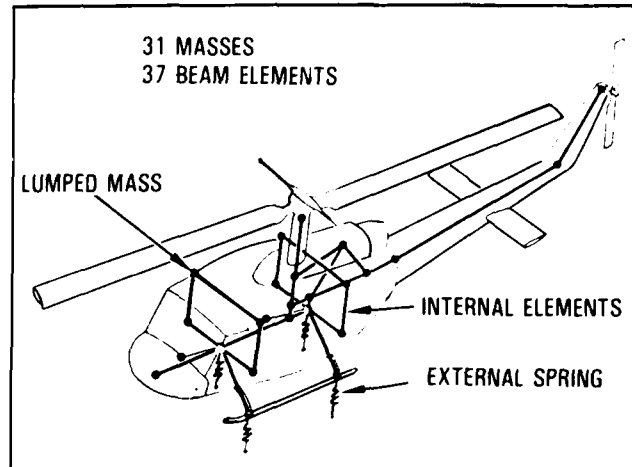

FIGURE 11. HELICOPTER ANALYTICAL MODEL (REFERENCE 13)

NOTE

- (a) ONLY LEFT SIDE SHOWN
- (b) BEAMS 6-7, 7-9, 6-10 NOT SHOWN FOR CLARITY

- MASS
- × MASSLESS NODE POINT
- INTERNAL BEAM OR RIGID CONNECTION
- SEAT/OCCUPANT DETAIL (UPPER TORSO)

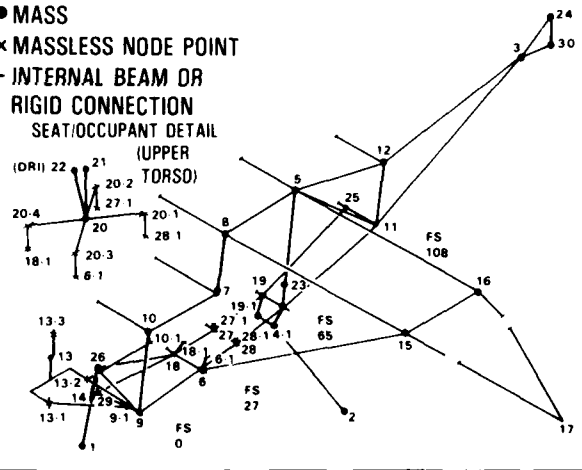
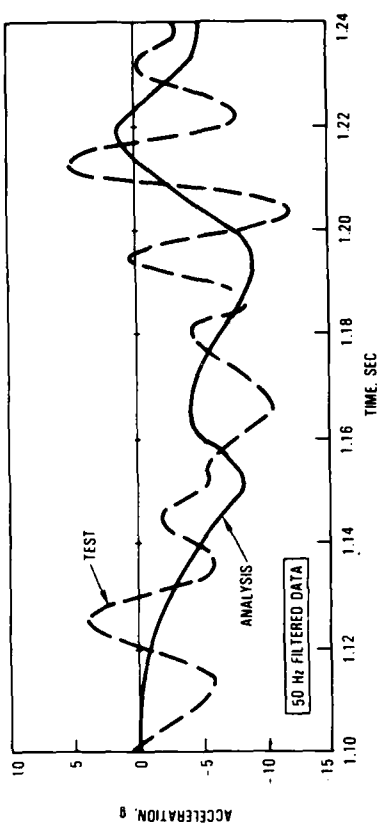
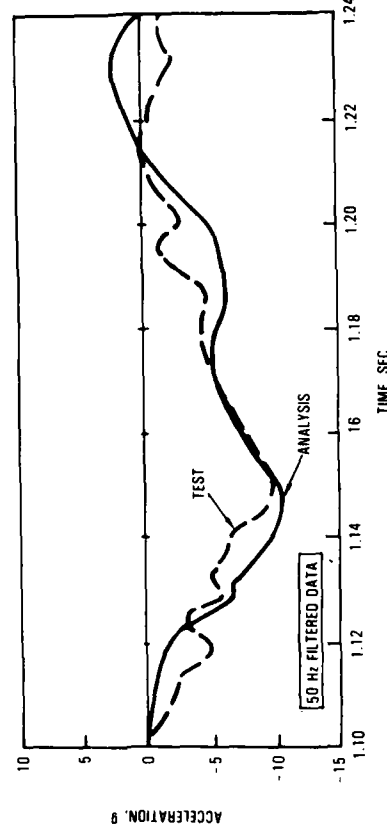

FIGURE 12. SINGLE-ENGINE HIGH-WING AIRPLANE ANALYTICAL MODEL (REFERENCE 14)

full-scale tests of these past and current aircraft due to cost, complexity and time constraints. Analyses validated with experimental data are the only viable alternative to extensive full-scale crash testing. Furthermore, the analytical application to the design of advanced transport aircraft of crash scenarios whose severity is established by validated analysis of past and current transport aircraft (with satisfactory crash survival records) provides us with the needed impact dy-



(A) VERTICAL



(B) LONGITUDINAL

FIGURE 14. COMPARISON OF ANALYSIS AND TEST MEASURED L-1649 FLOOR PULSE AT FS685 (REFERENCE 16)

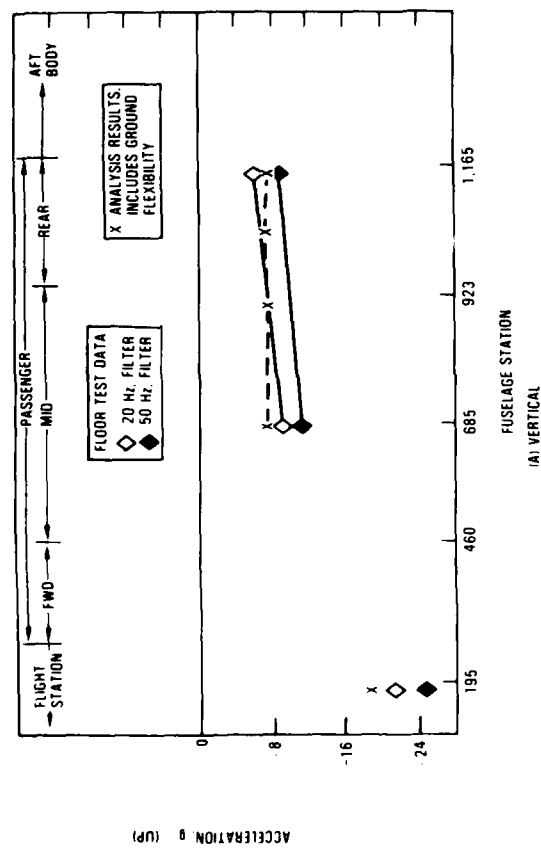

(A) VERTICAL

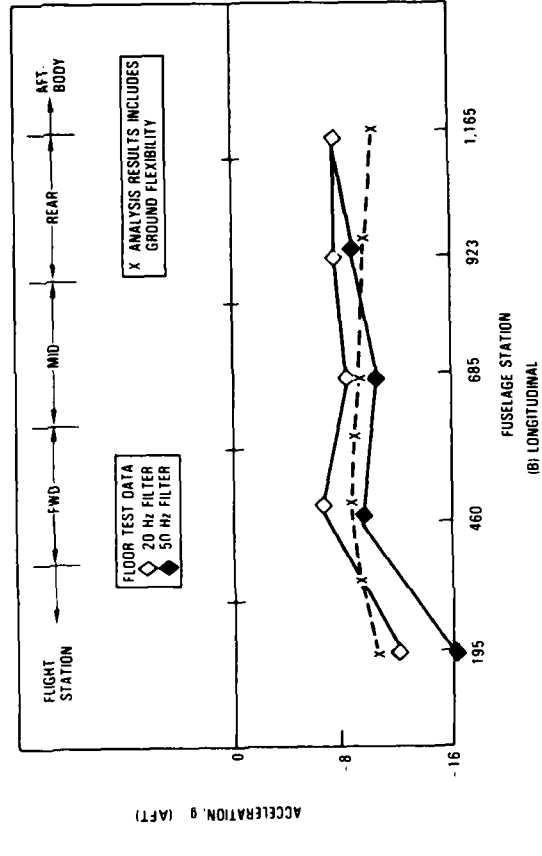

(B) LONGITUDINAL

FIGURE 13. ACCELERATION VERSUS FUSELAGE LOCATION, L-1649 6-DEGREE SLOPE IMPACT (REFERENCE 16)

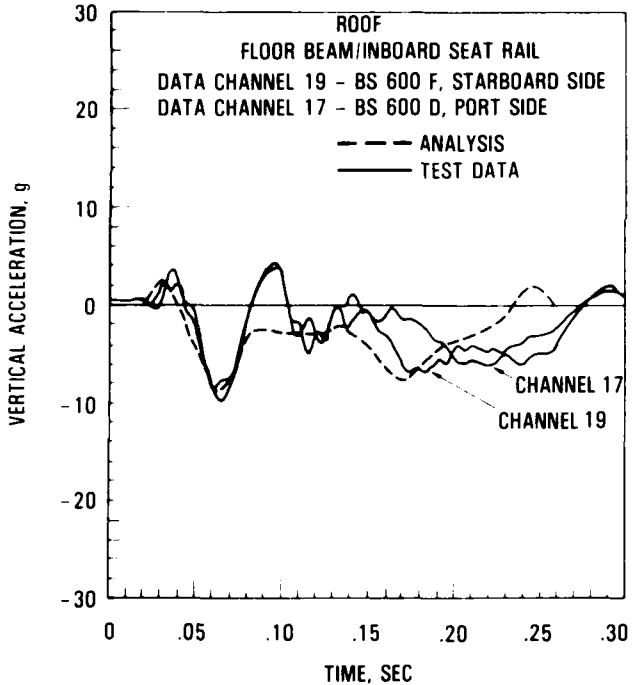
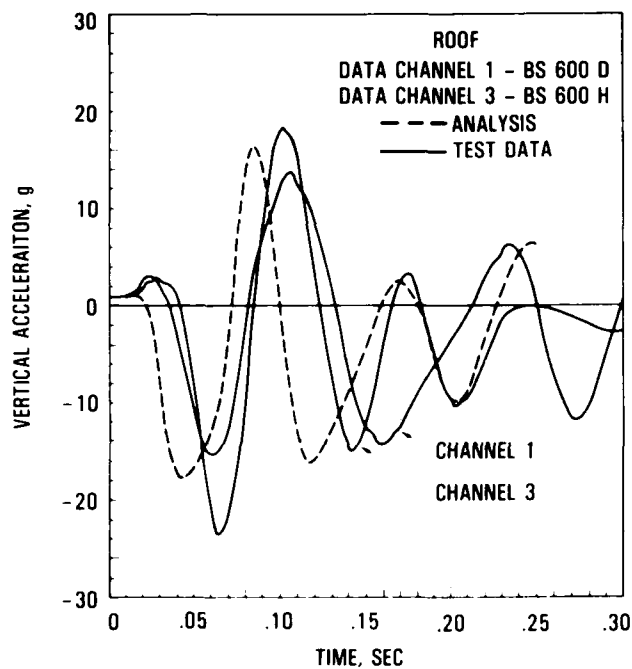

(a) FLOOR BEAM/INBOARD SEAT RAIL

FIGURE 15. COMPARISON OF NARROWBODY FRAME SECTION ANALYSIS AND TEST RESULTS (REFERENCE 20)

namics design criteria having its "foot firmly planted in the past" as we stride forward to new advanced design configurations and new materials.

Confidence is needed in the ability of the analytical procedures to represent the significant response parameters of transport airplanes during an impact. For rotary wing and light fixed-wing aircraft analytical modeling for determining impact responses has reached a level of acceptance after much correlation with test data and refinement of the procedures. For transport airplanes, particularly the large-size configurations several levels of modeling may be appropriate. For example, overall airframe behavior could be determined from a relatively coarse model taking advantage of available experimental data. More detailed models could then be applied to analyze critical regions (i.e., floor, seat/occupant, engine attachment, wing).

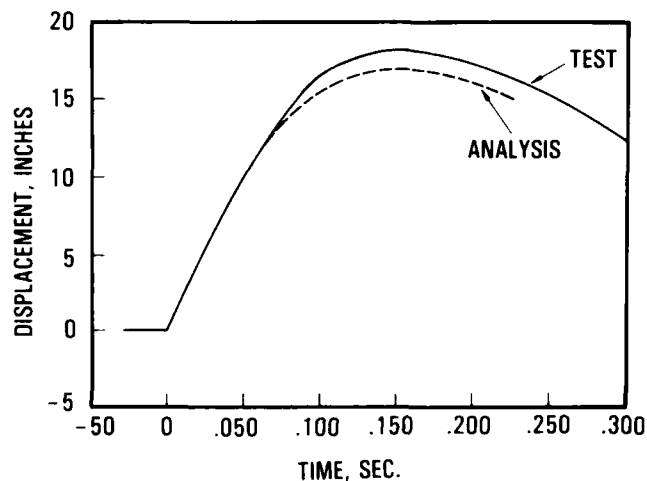

(a) VERTICAL DISPLACEMENT VERSUS TIME

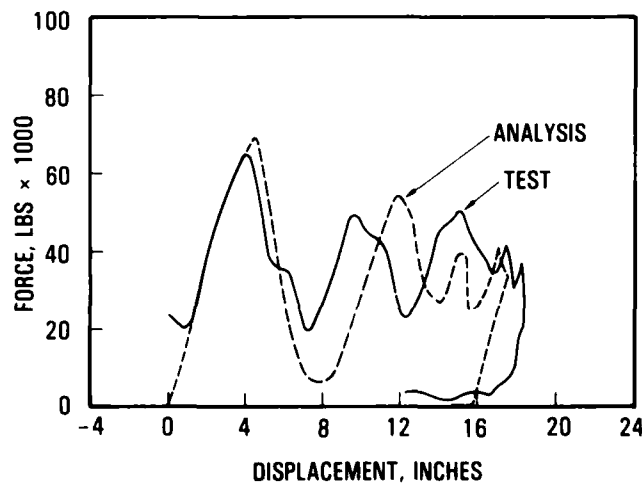

(b) FORCE VERSUS DISPLACEMENT, VERTICAL

FIGURE 16. COMPARISON OF NARROWBODY FRAME SECTION ANALYSIS AND TEST RESULTS (REFERENCE 20)

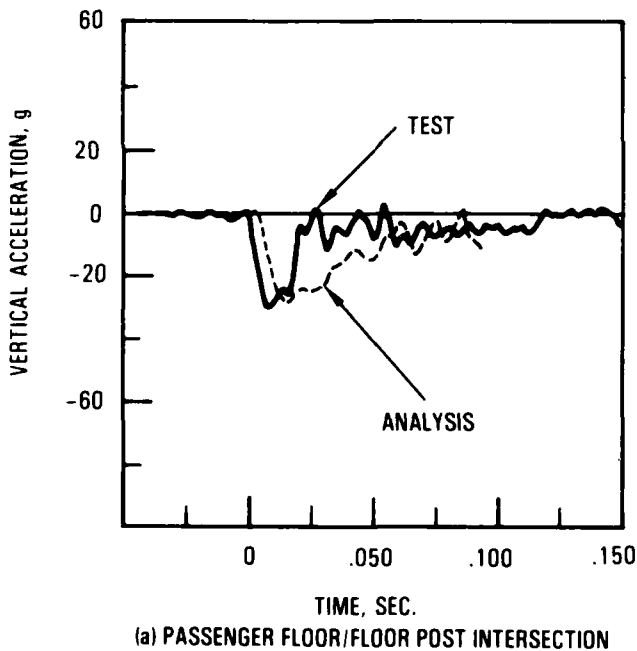
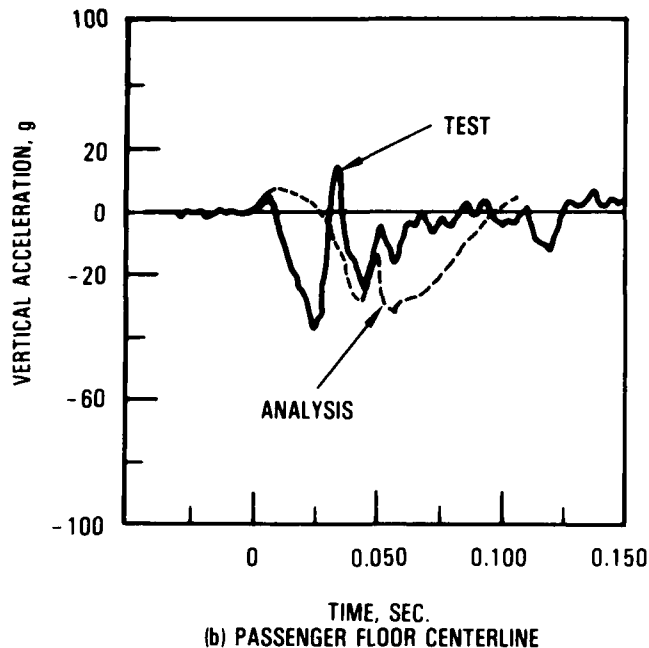

FIGURE 17. COMPARISON OF WIDEBODY FRAME SECTION ANALYSIS AND TEST RESULTS (REFERENCE 20)

Once a satisfactory model is developed, it needs to be applied to a wide range of survivable accident impact parameters and airplane configurations. From this effort, a definition of critical floor pulses will evolve which are then transmitted to the occupant. Dynamic

test requirements, in terms of change in velocity ( $\Delta v$ ), peak acceleration (g), pulse shape, and pulse direction must then be evaluated in light of current static load seat design and test requirements<sup>17</sup>. It is at this point that human tolerance criteria will be applicable as pass/fail criteria for measuring seat/airframe performance.

To this point our discussion has centered around structure of current metal designs. A major trend for the future is the increased application of advanced composite materials for primary structure. The accepted adage is that "composites must be at least as good as metals." To ensure this equivalence, a better understanding of differences in failure load, failure mode and energy absorption between current metal-designed structures and new designs using advanced composites, must be developed. Under a current NASA contract,<sup>18</sup> Lockheed is investigating the impact dynamic behavior of composite fuselage designs. Even closer at hand is the incorporation of seats using advanced composite materials. These seats could easily meet current static strength requirements while lacking the necessary energy absorption capability of metal designs.

There is additional effort needed beyond correlating analytical methodology with test data. Results of impact parameter studies, application to past and current design configurations, and the effect of using advanced materials must be evaluated to assess what, if any, design requirement changes are needed to ensure a high level of occupant survivability in advanced transport-airplane accidents. Figure 20 depicts accomplishments to date and at the same time shows the effort that remains. Among the tasks to be completed are:

- Correlation of analysis and CID tests results
- Refinement of airframe and floor models based on the CID test results
- Performance of parametric studies using validated analytical models for candidate crash scenarios to ascertain the envelope of airframe structural integrity for past and current transport aircraft having satisfactory crash survival records.
- Quantification of seat crash dynamic floor pulse through analysis of:
  - Existing test data
  - Application of analysis to candidate crash scenarios

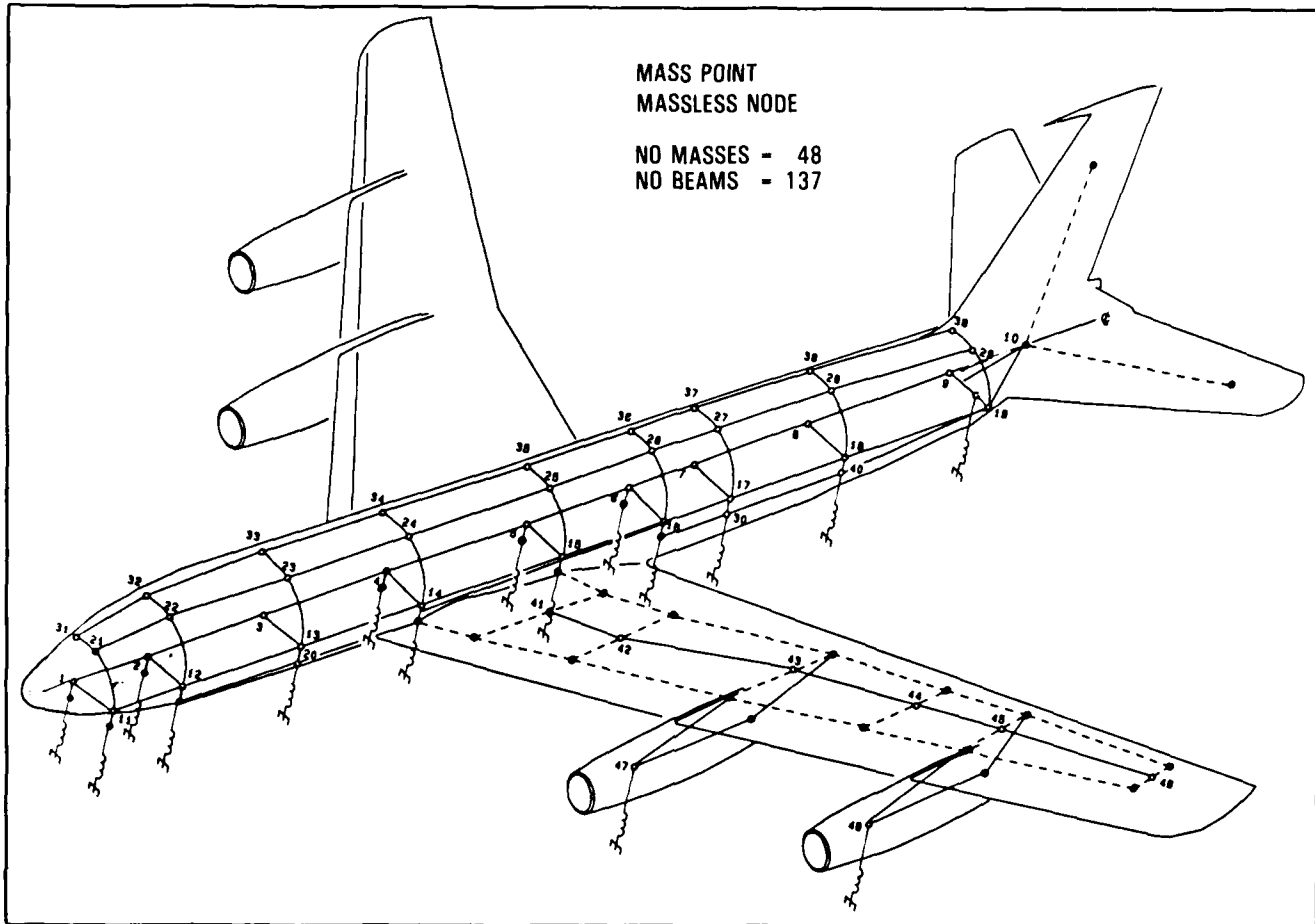

FIGURE 18. EXPANDED CID MODEL (REFERENCE 20)

- Tests to verify the influence of design and impact parameters.
- Development of compliance procedures for seat and occupant systems
  - Dynamic tests
  - Static tests based on dynamic equivalence
  - Analysis using verified acceptable procedures
  - Performance criteria for occupant, restraint system, seat, and attachments
- Application of verified analytical procedures to new advanced transports will require the creation of a component test database. These component tests would:
  - Use representative advanced structural concepts
  - Use realistic impact conditions
  - Identify critical failure modes
  - Use advanced composite or advanced metallic material designs
- Development of impact dynamics model representations and procedures in support of future designs which use advanced materials for critical energy absorbing regions.



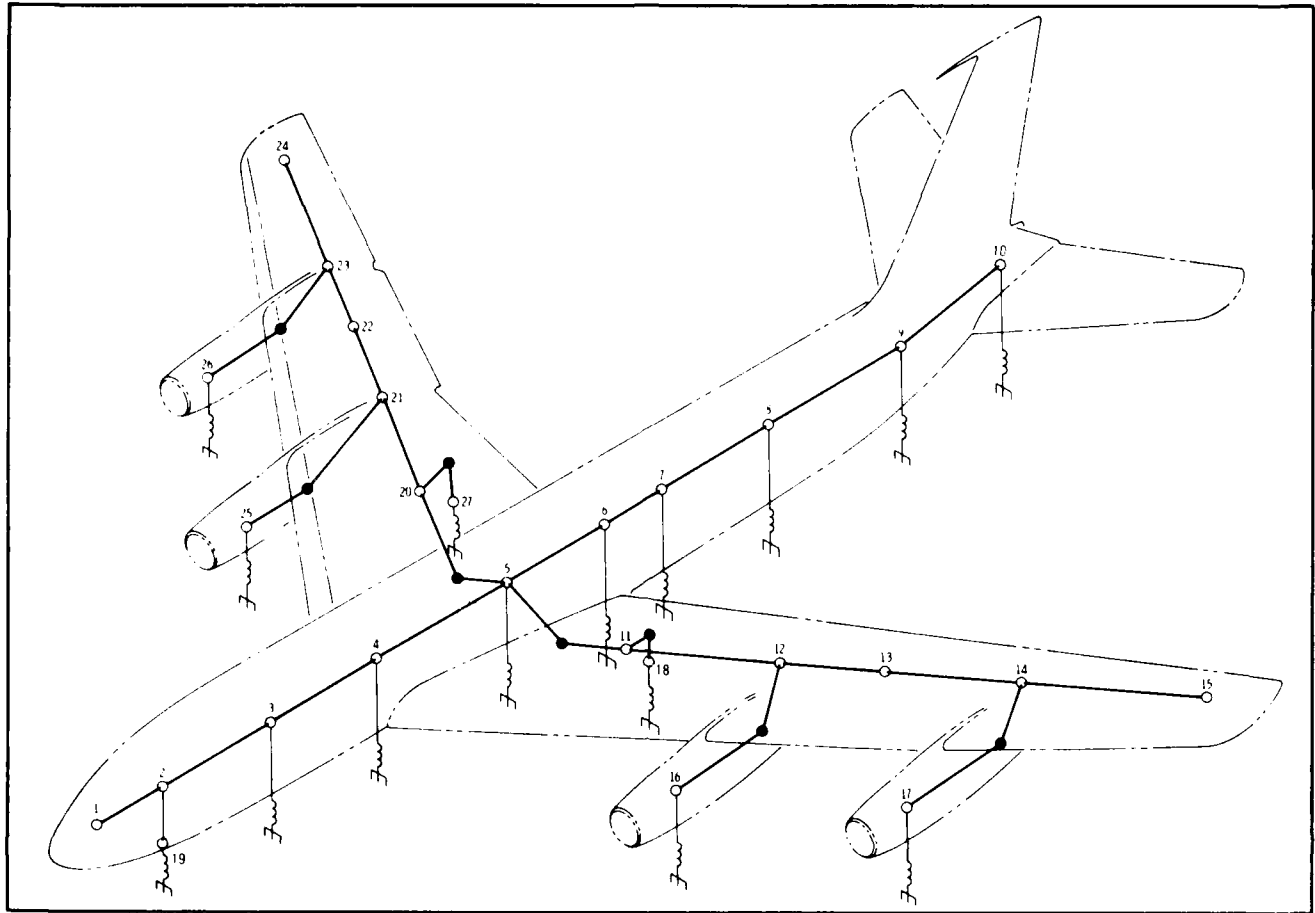

FIGURE 19. CID STICK MODEL (REFERENCE 20)

The achievements to date are noteworthy; however, without the additional effort required to complete the program, the results are not sufficient to quantify changes to existing design criteria. If decisions are made to change criteria prematurely there is a likelihood that undue penalties will be placed on the airframe design without any benefit to occupant survivability.

## CONCLUSIONS

The development of a technical database and the methodologies necessary to assess the dynamic impact environment and occupant survivability characteristics of civil aircraft has progressed rapidly in the last five years. A thorough review of transport airplane accident history has been performed and has shown the accident record for occupant safety in survivable accidents is excellent. To help ensure that this record is main-

tained with future airframe designs, candidate crash scenarios, which will be further evaluated, have been formulated. Data have been obtained from section impact tests, as well as controlled full-scale airplane impact tests. Analytical modeling has been performed on full-scale airframe sections and complete airplane impact tests, and improvements to the methodology have been incorporated.

While the accomplishments to date have been significant and provide an optimistic look to the future, more work must be done before changes in design requirements can be enacted. In particular, the methodology needs to be validated, then applied in parameter sensitivity studies to determine the envelopes of impact severity that have been inherently provided by the overall airframe structural integrity of past and current transports. Measures of performance must be established for both structural and seat integrity.

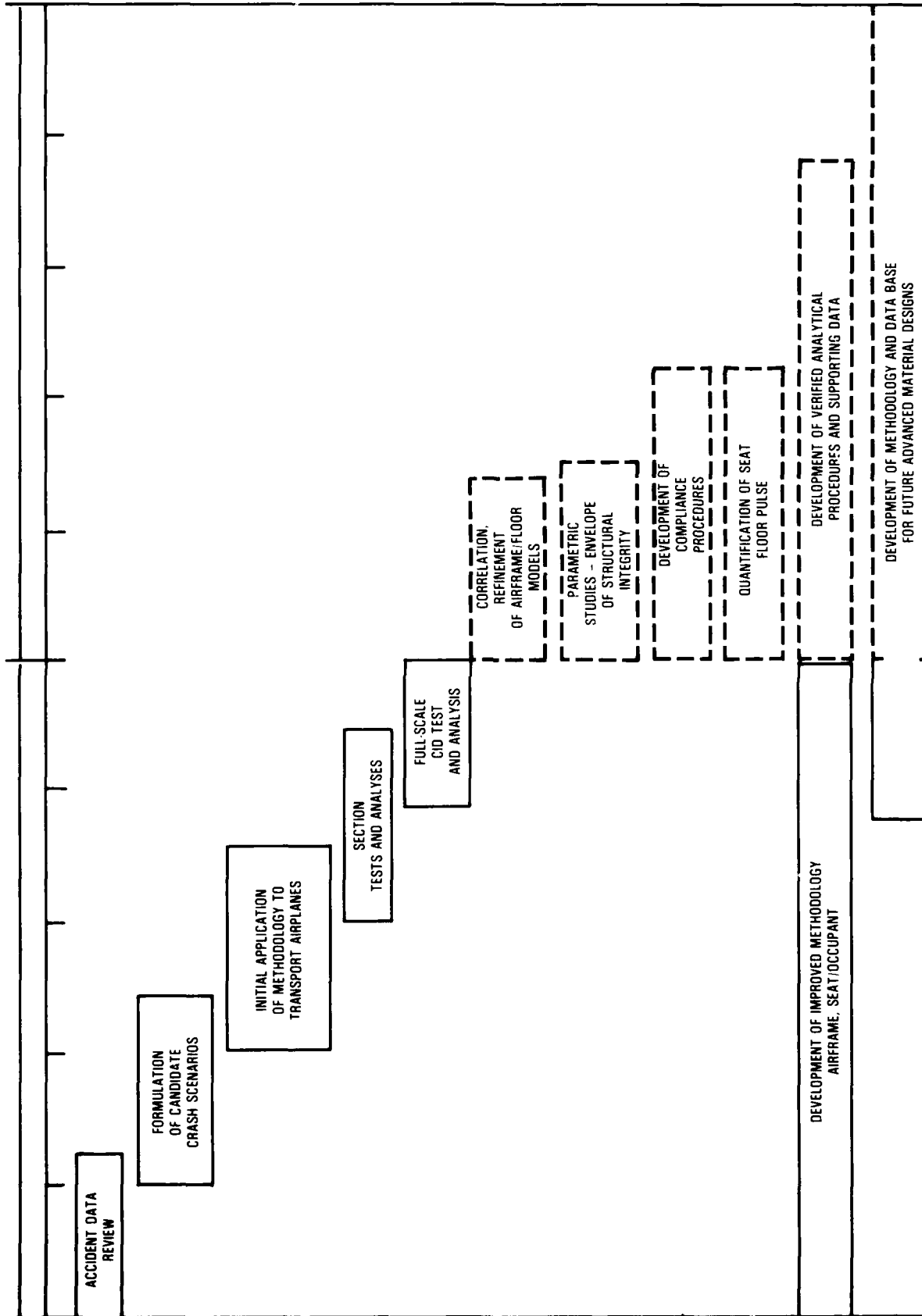
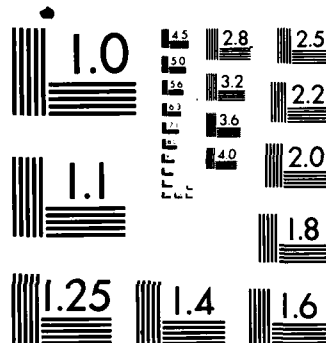

FIGURE 20. IMPACT DYNAMICS PROGRAM, 1980 - 1989





MICROCOPY RESOLUTION TEST CHART  
NATIONAL BUREAU OF STANDARDS-1963-A

## REFERENCES

1. Thomson, R. G. (NASA), Caiafa, C. (FAA), "Designing for Aircraft Structural Crashworthiness," AIAA Paper 81-0803, Atlantic City, New Jersey, May 26-28, 1981.
2. Federal Register/Vol. 49/No.185/Sept. 21, 1984/Proposed Rules
3. Widmayer, E. and Brende, O. B., "Commercial Jet Transport Crashworthiness," Boeing Commercial Airplane Company, NASA CR 165849, FAA Rept. DOT/FAA/CT-82/86, March 1982.
4. Wittlin, G., Gamon, M. A., and Shycoff, D., "Transport Aircraft Crash Dynamics." Lockheed-California Company, NASA CR 165851, FAA Rept. DOT/FAA/CT-82/69, March 1982.
5. Cominsky, A., "Transport Aircraft Accident Dynamics," McDonnell Douglas Corp., NASA CR 165850, FAA Rept. FAA-RD-74-12, March 1982.
6. Thomson, R. G., Caiafa, C., "Structural Response of Transport Airplanes in Crash Situations," NASA TM 85654, June 1983
7. Reed, W. H., et al, "Full-Scale Dynamic Crash Test of a Douglas DC-7 Aircraft," Aviation Safety Engineering and Research, Federal Aviation Administration, Washington, D. C., FAA Technical Report ADS-37, Oct. 1965.
8. Reed, W. H., "Full-Scale Dynamic Crash Test of a Lockheed Constellation Model 1649 aircraft," Aviation Safety Engineering and Research, Federal Aviation Administration, Washington, D.C., FAA Technical Report ADS-38, Oct. 1965.
9. Williams, S. A. Hayduk, R. J., "Vertical Drop Test of a Transport Fuselage Section Located Forward of the wing," NASA TM 85679, Aug. 1983.
10. Williams, S. A., Hayduk, R. J., "Vertical Drop Test of a Transport Fuselage Center Section Including the Wheel Wells," NASA TM 85706, Oct. 1983.
11. B707 Fuselage Drop Test Report, Calspan Report No. 7252-1, March 1984.
12. DC-10 Fuselage Drop Test Report, Calspan Report No. 7251-1, Sept. 1984.
13. Wittlin, G. and Gamon, M. A., "Experimental Program for the Development of Improved Helicopter Structural Crashworthiness Analytical and Design Techniques," Lockheed-California Company, USAAMRDL-TR-72-72, May 1973.
14. Wittlin, G., Gamon, M. A., "Full-Scale Crash Test Experimental Verification of a Method of Analysis for General Aviation Airplane Structural Crashworthiness," Lockheed-California Company, FAA-RD-77-188, Feb. 1978.
15. Armen, H., Pifko, A., Levine, H., "Nonlinear Finite Element Techniques for aircraft Crash Analysis," Aircraft Crashworthiness, University Press of Virginia, 1975, pp. 517-548.
16. Wittlin, G. and Lackey, D., "Analytical Modeling of Transport Aircraft Crash Scenarios to Obtain Floor Pulses," Lockheed-California Company, DOT/FAA/CT-83-23, NASA CR 166089, March 1983.
17. Federal Aviation Regulations: "Part 25 - Airworthiness Standards Transport Category Aircraft," April 1982.
18. Contract NAS1-17698 "Transport Composite Fuselage Technology: Acoustic Transmission and Impact Dynamics," Lockheed-California Company (in progress).
19. NASA Contract NAS1-16076, Boeing Airplane Company (in progress).
20. FAA Contract DTFA03-84-C-00004, Lockheed-California Company (in progress).
21. Tye, W. "Civil Aviation Safety, Aircraft Engineering," Sept. 1980.



**Richard F. Chandler**  
**Supervisor, Protection and Survival Research Laboratory**  
**FAA Civil Aeromedical Institute**

Richard F. Chandler is presently Supervisor of the Protection and Survival Research Laboratory at the FAA Civil Aeromedical Institute in Oklahoma City, OK. His background in human tolerance to impact and restraint system performance began in 1955 at the U.S. Air Force Aeromedical Research Laboratory at Holloman Air Force Base, New Mexico, under the direction of Col. J. P. Stapp. In 1967 he became Special Projects Manager in the National Bureau of Standards Office of Vehicle Systems Research, where he was responsible for directing research involving human response to automobile crashes. He joined the FAA in 1970. Mr. Chandler is a recognized specialist in seat and restraint system evaluation techniques, and has provided direction for numerous projects involving the DOT, NASA, DOD, and Manufacturers of Systems.

## SEATS, RESTRAINTS, AND CRASH INJURY PROTECTION

Richard F. Chandler

**Introduction.** The excellent safety record of the air transport industry in the United States is well documented. Years in which no fatalities occur as a result of aircraft crashes have become a realistic goal. Even when this goal is not achieved, the overall fatality rate is usually one of the lowest of all mass transport systems. This record was achieved through an accident prevention effort which encompasses all segments of the industry, and its success is a clear sign that continued emphasis on accident prevention is appropriate. However, when attempts are made to evaluate the performance of seat and restraint systems in transport aircraft crashes, it is found that the bulk of the data have been collected to define the cause of the accident and thus aid in accident prevention. Data relating to injuries, particularly passenger injuries, and rigorous correlation of those injuries with the cause of the injury is not included in most reports of accident investigations. For example, it is apparent that the classification of an injury as "serious" based upon the amount of time spent in a hospital tells little about the nature of the injury, but even when the injuries are documented in the (often unpublished) notes of the investigators, the descriptions are usually so general that an accurate assessment of the injury mechanism is impossible, and the problem is made even more difficult by lack of information which can place those injured passengers in a specific seat or location in the aircraft. The relatively few cases in which a reasonable "crash injury prevention" analysis can be made only serve to emphasize the lack of an adequate data base in a statistical sense.

What, then, can an investigator consider when faced with the problem of assessing the performance of seats and restraint systems in their role of reducing crash injury? Certainly, the reported injuries and problems with seat and restraint systems must be evaluated, because even though they may not be useful for statistically valid arguments, these reports provide clues as to potential problem areas. The so called "state of the art" must also be reviewed, since considerable resources have been devoted to increasing the state of the art of crash injury prevention in other forms of transportation. This work really applies to people rather than the form of transportation, and is useful in all seat and restraint system development. Finally, and perhaps most important, pragmatic common sense will aid in assessing the available data and in developing meaningful conclusions.

A thorough exploration of all these factors is beyond the scope of a brief paper such as this. Instead, the author will consider some of the major questions often asked, review some reported examples of seat and restraint performance, and indicate some current state of the art approaches to improvements in seat and restraint performance. Hopefully, pragmatic common sense will prevail in drawing conclusions from the discussion.

**Human Tolerance.** It is generally recognized that three basic considerations govern the chances of survival in a crash: the living space must be maintained, the occupant must be properly tied down to the vehicle, and the crash environment must be at a level which can be withstood by the occupant. This last consideration generates questions of defining the crash environment which can be withstood by a typical occupant of a civil transport. Over the years, we have come to call this "human tolerance," taking the terminology from the early military research by Stapp and others, and have looked to that research to provide guidelines for establishing acceptable levels of human tolerance.

Unfortunately, we have lost sight of the goal of that early work, which was to demonstrate that the acceleration and windblast environment generated in ejection from high speed military aircraft would not produce injury. With that knowledge, pilots would be confident that they could tolerate the ejection seat environment, and would choose to eject from an aircraft in an emergency situation rather than ride the aircraft down to a crash where they would more likely be injured. The word "tolerance" was used to describe an environment which was voluntarily acceptable to the occupant. Although the research was expanded to include studies of injury, we have often relied on these early military, voluntary human exposure limits as a basis for judging level of protection desirable in an involuntary crash environment. This is inappropriate for several reasons.

This military research was accomplished using young/mid-aged male subjects with sophisticated military restraint systems (although female subjects subsequently participated in tests, none were used in the tests which established the tolerance levels under discussion). While it can be argued that neither the subjects nor the restraint systems were representative of occupants and restraints found in civil transport aircraft, a more significant argument can be based on the limitation imposed by the voluntary nature of the tests.

Although there were a few notable exceptions, such testing was conducted only under carefully controlled conditions which were selected to prevent injury to the volunteer subjects. Even if injury did occur, it was transient and minor in nature. A limitation based on voluntary exposure with no injuries is inadequate for design of crash injury protection systems, since the goal of these systems is to prevent death or irreversible injury which will occur at levels greater than the voluntary exposure levels. Under the present state of the art, it is possible to use "injury criteria" rather than "human tolerance" in the development of crash injury protection systems.

Limitations based on injury criteria are even more difficult to obtain than those based on human tolerance since humans cannot be knowingly exposed to injury in a test environment. Injury criteria must be developed using a surrogate for the human; most commonly animals or cadavers, and the data which result must then be related to the living human occupant. This is not a simple matter and considerable research still remains to be accomplished. Nevertheless, certain criteria have been suggested which have been successfully used to develop crash protection systems in automobiles. Since the people who ride in automobiles are not different from people who ride in civil transport aircraft, and since the restraints in automobiles (to date) are similar to those in aircraft, these criteria should be equally applicable to crash protection systems in aircraft (See Note 1).

For the designer, a significant difference is immediately apparent between statements of injury criteria and of voluntary tolerance. Voluntary tolerance limits describe a crash environment, while injury criteria are limits placed on the response to a crash environment. While a statement of a crash environment could serve as a starting point for a design (and would be described in terms that are familiar to the designer), injury criteria serve as a pass-fail means of judging if the design has achieved some level of occupant crash protection. Moreover, there are no classical design methods familiar to the designer which will assure from the onset that the injury criteria can be achieved. The moment of truth comes during a dynamic test, an uncomfortable situation for an aircraft seating systems designer who does not have experience which can guide his efforts to a successful crash injury protection design.

Nevertheless, the dynamic test procedure represents the current state of the art in evaluating the occupant crash injury protection provided by seat, restraint or interior design. The method has been used for many years by the military services for evaluating aircraft systems, and has proved successful in evaluating automotive crash injury protection systems. More recently the General Aviation Safety Panel, with the participation of manufacturers represented by the General Aviation Manufacturers Association and others, has recommended a dynamic test procedure for evaluating seats, restraints and interiors for small general aviation aircraft (See Note 2).

**Existing Seating and Restraint Systems.** While the documentation of seat and restraint system performance in civil aircraft crashes has not been consistent, and (fortunately) is further limited by the infrequent occasion of a crash, we can obtain some indication of potential problems if we combine our observations with the pragmatic common sense mentioned earlier. For example, consider the aircraft shown in Figure 1, which skidded off the runway and groundlooped to the right after landing. The crash environment was not severe, and the fuselage remained intact, but 23 of the 50 occupants on board reported injuries. Figure 2a shows the interior of the aircraft. Seats on the right side of the aircraft were found displaced laterally into the aisle, even though they were designed for 3.0g (static) loads, and arm rests were found to be broken or bent.

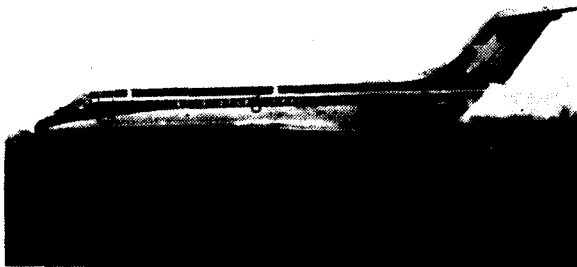

Figure 1



Figure 2a



As a consequence of the lateral loads, several seat legs separated from the seats, Figure 2b, and at least one leg broke the floor track lips, Figure 2c.

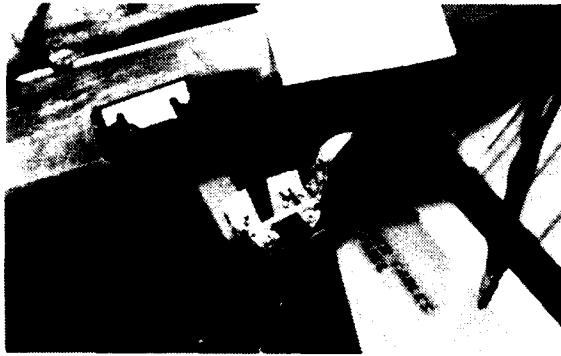

Figure 2b

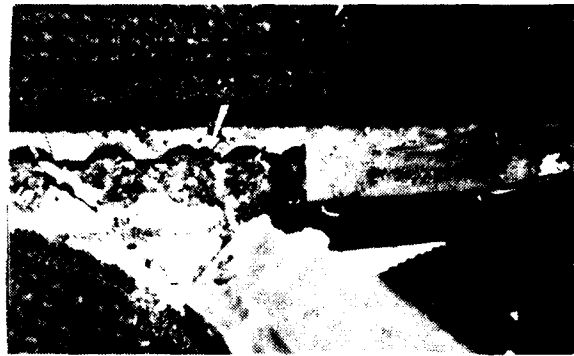

Figure 2c

Most of the minor injuries occurred on the left side of the body and resulted from contact with the armrests, the seat belt, seat backs or aircraft interior (flailing injuries). The one serious injury reportedly resulted from contact with the aircraft interior. The most obvious conclusion to be drawn from this example is that the seats broke and deformed laterally into the aisle in a crash environment that was not life threatening and where the fuselage was well able to maintain living space. As long as emergency evacuation of the aircraft is regarded as a primary safety feature, the aisle restriction which resulted from the seat deformations must be regarded seriously. Furthermore, since several seats broke loose from the floor, the occupants would not have been protected had the crash sequence continued. Other, competitive, seat designs may accommodate this type of deformation without failure. New seat criteria could be developed which could distinguish, and preclude, this failure mechanism. Another, somewhat more obscure, finding can be drawn from the failure of the floor track as the seat moved laterally. Typically, this occurs because there is no lateral relief for bending moments transmitted through the floor track fitting. Unfortunately, this is a common design characteristic of floor track fittings, but it could easily be changed if the criteria for acceptance required that it be done.

While the preceding discussion is based on just one example, several recent studies have indicated that seat failures in aircraft crashes are often associated with "floor disruption." This has often been used to imply that the severity of the crash was so great that the fuselage was destroyed and seat failure was a natural consequence. But floor disruption can occur in crashes well within survivable range, as shown in Figure 3.

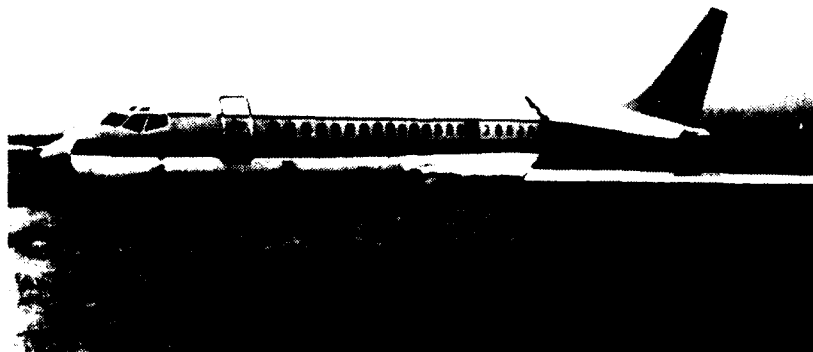

Figure 3

The most serious injury to a passenger in this aircraft was a broken clavicle, yet the conditions of the crash were enough to cause floor disruption, as shown in Figure 4.



Figure 4

Traditionally, aircraft seats have been designed and tested under the presumption that they will be attached to the aircraft through a rigid floor. No consideration is given to the fact that, during a crash, deformations and floor warpage are likely. If the seats are so rigid that they cannot accommodate floor warpage, they are likely to break the floor track or the leg attachment. This was recognized by the military and the General Aviation Safety Panel, and their test procedures have provisions for demonstrating the ability to accommodate floor warpage. Some transport aircraft seats can also accommodate floor warpage and still carry significant crash loads, so that it would appear that this capability is available if it were to be required.

At this point it would be appropriate to recognize a semantic problem with the use of the word "strength" as applied to aircraft seats. The easiest way to achieve additional strength in a structure is to use more material or a different material with a higher ultimate failure limit. Unfortunately, both of these approaches tend to make a structure more stiff, exactly the wrong result if we hope to also achieve improved accommodation of floor warpage. Those who have hoped to encourage improvement in aircraft seating systems by calling for "stronger" seats, when they really desire "more crashworthy" seats, have met opposition because of this semantic problem.

The compiled injury statistics from transport crashes show that back injuries are most often reported, followed by injuries to the legs, arms and shoulders, head, chest and pelvis, in that order. Although specific causes of these injuries remain elusive, the reported predominance of back injuries warrants concern. Such injuries can occur from a number of causes (the major injury in the crash shown in Figure 1 was reported as a spinal fracture caused by contact with the aircraft interior), but the possibility that the seat and restraint systems may contribute to these injuries cannot be overlooked. For example, the flexure which can occur if the body submarines around a loose or improperly located seat belt can promote back injury either through strain in the posterior ligaments or compression of the anterior vertebrae if a downward force is also present. It is also not unusual to find seats equipped with a soft, non-energy absorbing, seat cushion placed over a rigid seat frame bottom, the same condition which promoted back injuries in military ejection seats reported in the 1950's. A stronger, more rigid, seat could aggravate this condition. Military specifications for helicopter seats and the new General Aviation Safety Panel recommendations have included test procedures intended to limit these types of injuries, and more crashworthy, deformable seats have been developed in accordance with those recommendations.

Injuries to the legs, arms, shoulders, chest and head, when related to the performance of seats with only seat belt restraint systems, are most likely associated with the flailing reaction of the occupant to the crash

environment. Presently, there are no generally applied criteria for judging the ability of a transport aircraft seat and restraint system to limit these injuries. Consider, for example, the seat with the fold down center tray shown in Figure 5.



Figure 5

To be useful, the tray must fold down with a low activation force, measured at 18 pounds on the seat shown. In a crash, the head, without being injured, could easily knock the tray down. It leaves an upright stub seat back, padded with about 1/4 inch of soft foam rubber under the upholstery. Under this foam is the detent pin for the tray back latch, attached to a rigid, thin stub seat back, shown in Figure 6.



Figure 6

This pin and stub back are in the head, neck or chest contact area of the strike envelope of an occupant flailing around a lap belt (the exact contact point would depend on occupant size, seat pitch and the crash conditions). The potential for penetrating injury from the pin and cosmetic injury or crushing injury from the stub back should be apparent (See Note 3). Again, other designs do not have this problem, so it would appear that seat criteria which brought attention to this injury potential could be achieved without new cost.

**Crash Environment.** Several recent studies have attempted to define the conditions under which transport aircraft crash. In reviewing these studies it becomes obvious that there are numerous conditions which influence the crash environment. Indeed, even though crashes can be grouped together in certain broad categories, almost every crash seems to have certain unique characteristics pertinent to injury prevention. If one were concerned about creating some criteria to form the basis for improvements in the crash injury protection offered by seats and restraint systems, it would appear that selecting any single crash condition would not represent the variety actually experienced. In addition, the crash conditions most often are described in terms of the approach conditions of the aircraft with respect to earth, and do not describe, in useful analytical detail, the energy absorption characteristics of the aircraft. This encourages endless argument about the relative benefit of large body vs. narrow body vs. small transport crash characteristics, conventional material vs. composite material energy absorption, etc., without much progress towards establishing useful dynamic criteria for the seat designer. Perhaps another approach could be considered. The load carrying ability of the floor tracks found in aircraft is one limitation in the tie down chain for the occupant. These tracks are similar in many aircraft. If the seat were matched to the track, i.e., loads which could be applied by the seat to the floor track were equal to the ability of the floor track to carry those loads, then a balanced design could result (it might be argued that we should require a better floor track, but the author's experience indicates that attempts to alter major airframe components are not productive). If the seat and floor track were matched in their ability, it should be possible to select a dynamic test condition which would generate the intended loads. Conditions of floor warpage, downward components and lateral components could be included, and appropriate injury criteria could be selected to indicate the success of a design in a test. While some judgment would be required in selecting these criteria, the experience of the *General Aviation Safety Panel shows that agreement can be reached if done in a positive working environment.*

**Other Factors.** Several other considerations should be mentioned that don't seem to fit anywhere else in this report. While a certain commendable level of crash injury protection has been achieved in transport aircraft seat systems, significant changes are taking place which may jeopardize the gains which have been made over the years. These seats have evolved over 20 to 30 years to their present state. The people responsible for that evolution are approaching retirement or are moving on to larger responsibilities, and their experience, being largely undocumented, is not available to new designers or to new companies moving into this field. Moreover, the designer of a new seat is faced with challenges of economy and material selection that are much more difficult than in the past. These challenges will naturally lead to a design which is a compromise, and those design goals which are most strongly stressed will govern. Some of these will affect the crash protection capability of the seat and restraint system. For example, new materials, particularly composites, can provide excellent strength with low structural weight.

Unfortunately, these materials have relatively poor energy absorption characteristics unless carefully used in a design concept which emphasizes energy absorption. Traditional materials have inherently better energy absorption properties, and these properties have contributed to seat performance in many crashes. Yet, there is no requirement for energy absorption in the seat, and a designer could easily overlook this property when pressed by concerns of cost and weight. Several other examples could easily be mentioned. In the quest for higher passenger density, the seat pitch is often decreased. But, does the designer consider the loads imposed on the seat by the knees of occupants seated in the following row? Probably not, because it is not a design requirement. But these loads would be more likely considered than the injury potential on the occupant's knees. To gain more space, seat back thickness must be decreased, making the design of a breakover seat back more difficult. Fixed seat backs can now be found in service. This means that the occupant seated behind the seat is likely to hit the top of the seat with his head or neck. Is the designer familiar with the 20-year-old literature which illustrates potential injury from this source? Were meaningful tests accomplished to demonstrate crash injury protection? Since they are not required by current

criteria, we can't be sure. To save weight, the seat back can be made shorter. Would this increase the potential for injury? Again, without criteria for evaluating this change, we can't be sure.

The lack of uniform performance criteria has effect even when seat and restraint systems are carefully developed. For example, one recent effort involved an improved cabin attendant restraint system. An extensive industry effort included literature searches, evaluation of several design concepts and computer modeling (Figure 7), and several dynamic tests were conducted by the Civil Aeromedical Institute on the final design concept. Even though the maximum shoulder belt angle evaluated in this development was 35 degrees, at least one user chose to install the shoulder belts at an angle approaching 80 degrees, shown in Figure 8. Since no uniform criteria exist to evaluate the ability of a system to protect against crash injury, the user is not obligated to demonstrate that this change did not degrade the performance of the system.

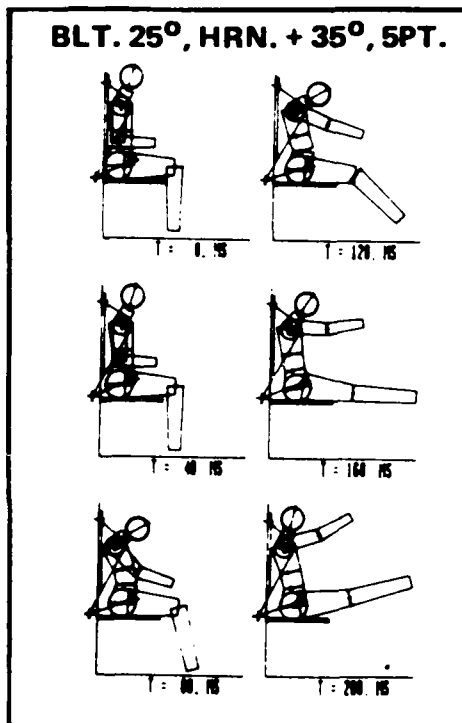

Figure 7



Figure 8

**Conclusions.** This report has attempted to illustrate several concerns regarding the performance of seat and restraint systems in a crash. Examples have shown seats breaking under lateral loads which were insufficient to cause serious injury to the occupants, with lateral displacement which obstructed the aisle, and, since there is no relief of lateral moments at the floor track fittings, caused the floor track to break. Floor deformation was illustrated, and it was noted that floor disruption of some kind is often reported in crashes with seat failure. Nevertheless, most seats are designed and tested under the assumption that the floor will always be flat. Voluntary whole body human tolerance to impact was mentioned, with the conclusion that these tolerance limits are inappropriate for seat design limitations. The concept of injury criteria was introduced as the "state of the art" technique for evaluating crash injury protection through dynamic testing. Illustrations of potential injury sources in some current seat and restraint installations were given.

It was also pointed out that accident investigations have not consistently reported seat or restraint problems, or injuries, in a manner which would allow rigorous analysis of the findings. This coupled with the infrequent occurrence of crashes in the transport environment makes meaningful statistical analysis of

seat, restraint and crash injury problems most difficult. Without statistical basis, we must rely on observations, good judgment, and the state of the art to develop improved criteria for crash injury protection for transport seat and restraint systems. The goal of improved criteria should be to establish some priority for seat and restraint system performance in a crash, particularly regarding crash injury protection, so that all designers would include these conditions in the design process. There are many systems in service with good crash performance features. That they exist is evidence that they are feasible and can be produced in a competitive market. Improved criteria could assure that the good features become widespread, and could eliminate those minor faults which become major problems.

**Acknowledgments.** The author wishes to acknowledge the assistance of Mr. Lee Lowery and Ms. Marlene Crane in selecting and providing material for this report.

**Note 1.** A draft Advisory Circular on Human Exposure to Impact was issued by the FAA on September 24, 1984. This document has further discussion regarding human tolerance to impact and injury criteria.

**Note 2.** The General Aviation Safety Panel, composed of a broad representation of the general aviation community, has developed new performance criteria for seats and restraint systems for small aircraft (less than 10 occupants). These criteria include two dynamic tests at levels up to 26g, and provide pass/fail criteria based on occupant protection from injury as well as structural performance of the system. These recommendations have been formally presented to the FAA for consideration for regulatory implementation.

**Note 3.** The performance of padding in preventing crash injury is often overestimated. Upholstery foam (comfort foam) has poor energy absorbing properties, and cannot be expected to provide protection. It may actually contribute to injury by "bottoming" under impact loads. Even padding with good energy absorbing qualities is best used to distribute the contact load over a body segment, so that locally high impact pressures are avoided. The structure supporting the energy absorbing padding should crush at loads below those which would cause injury, and absorb most of the energy of the impact.



**Constantine P. Sarkos**  
**Program Manager, Aircraft Cabin Fire Safety**  
**FAA Technical Center**

Constantine Sarkos is Technical Program Manager of the Federal Aviation Administration (FAA) Cabin Fire Safety Program conducted at the FAA Technical Center. The current program encompasses a broad range of in-house and contractual activities, including full-scale testing, modeling, small-scale test development, fire hazard assessment and fire management and suppression. Mr. Sarkos joined FAA as a Project Engineer in 1969 after working at the General Electric Re-Entry Systems Department. He has participated in or managed various projects related to the flammability, smoke and toxic gas emissions from cabin materials, fire management and suppression, and survival and evacuation. Mr. Sarkos has B.S. and M.S. Degrees in Mechanical Engineering from Rutgers University.

# EFFECTIVENESS OF SEAT CUSHION BLOCKING LAYER MATERIALS AGAINST CABIN FIRES

Constantine P. Sarkos  
Richard G. Hill

## ABSTRACT

Materials are available for preventing or retarding aircraft cabin fires involving urethane foam seat cushions. Realistic fire tests performed in a wide-body test article demonstrate that some in-flight and ramp fires can be prevented, and that the allowable time for safe evacuation can be significantly extended during a survivable postcrash fuel fire, when the urethane foam seat cushion is covered by a "blocking layer" material.

## OBJECTIVE

The main objective of this paper is to describe the effectiveness of aircraft seat cushion blocking layer materials when subjected to various realistic cabin fire conditions.

## BACKGROUND

The flammable nature of foamed plastics, in general, has focused attention on protecting or replacing urethane foam in such widespread residential applications as household insulation, upholstery furniture, and mattresses (reference 1). In transport aircraft, the large number of passenger seats constitute the major application for flexible urethane foam. Accordingly, the Special Aviation Fire and Explosion Reduction (SAFER) Advisory Committee, convened by the Federal Aviation Administration (FAA) to "examine the factors effecting the ability of aircraft cabin occupants to survive in the postcrash environment and the range of solutions available," made the following recommendation: "Develop for aircraft seats, fire blocking layers (e.g., fire barriers) for polyurethane foam cushioning material, in order to retard fire spread" (reference 2). This paper describes FAA test results on candidate blocking layer materials evaluated in wide-body cabin test article under various realistic fire conditions. The effectiveness of the blocking layer material is judged by comparing seat test results, with and without blocking layer protection, under identical fire test conditions.

Aircraft cabin fires may be categorized as follows: ramp, in-flight, and postcrash. The characteristics of each are sufficiently distinct to require separate analysis. Ramp fires occur when an aircraft is parked at the ramp, usually in an unattended condition, but on less frequent occasions during servicing. Past ramp fire experience has resulted in loss of property but not loss of life. For example, a 727 was extensively damaged as a result of a fire originating from discarded smoking material placed inside a plastic disposal bag located adjacent to a passenger seat (reference 3). The loss was estimated at \$3,200,000. The elapsed time before discovery of the fire, approximately 50 minutes, is consistent with the ability of polyurethane foam to support smoldering combustion for long periods of time, before transitioning to open flaming. Most in-flight fires occur in accessible areas, such as a galley, and are detected and extinguished promptly. On rare occasions in-flight fires become uncontrollable, leading to large loss of life. The most recent example was an L-1011 in-flight cargo compartment fire over Saudi Arabia, eventually claiming all 301 occupants onboard the airplane (reference 4). The fire became life threatening when flames penetrated through the cabin floor, involving seats and other interior materials. In the United States all fatalities attributable to fire occur in postcrash fire accidents (reference 5). Most postcrash cabin fires are accompanied by a large fuel spill fire. Burning interior materials may effect the survivability of cabin occupants in those accidents with a predominantly intact fuselage and a fuel fire adjacent to a fuselage opening, such as a rupture or door opening (references 6 and 7). Under these conditions, seats near a fuselage rupture or door opening will be subjected to intense thermal radiation and/or flames from the fuel fire.



## DISCUSSION

**BLOCKING LAYER MATERIALS** — Over the past 20 years or more, the aircraft industry has constructed aircraft seat cushions from urethane foam, which possesses low weight and excellent comfort, resiliency and durability. In applications where weight is not a consideration, neoprene foam is a viable replacement for urethane foam when improved fire performance becomes a requirement (reference 8). However, neoprene foam is approximately 3 to 4 times as dense as urethane foam, and would create a prohibitive weight penalty in aircraft seating. A thin, lightweight blocking layer material, encapsulating the urethane foam to prevent or retard fire involvement of the urethane, is an attractive protective measure for aircraft seating. The blocking layer material is an interliner between the upholstery cover and foam cushion. In some cases it can also function as a ticking.

Table 1 is a list of candidate blocking layer materials for aircraft seating evaluated in this paper. There are two basic types of blocking layer materials; (1) foams, and (2) aluminized fabrics. The foam blocking layers are neoprene (polychloroprene), which is glued to the urethane foam. Upon exposure to heat or flame, neoprene foam blocking layers produce a relatively stable char, which acts as an insulator and reduces the rate of heat transfer to the urethane foam. Of the two foams listed, only Vonar® is marketed as a blocking layer; LS-200 is normally used as a full cushion. The lightest Vonar blocking layer has a cotton scrim and weighs 23.5 oz/yd<sup>2</sup>.

A more recent blocking layer consideration is the aluminized fabrics, used primarily in protective clothing against heat or fire. These materials were identified by the National Aeronautics and Space Administration (NASA) as a possible alternate to a Vonar blocking layer at approximately ½ the weight (reference 9). Fabric blocking layers are designed to cover the urethane foam in the same manner as an upholstery cover, with the open end being sewn or fastened in some manner to completely cover the urethane. Fabric blocking layers are composed of high-temperature synthetic fibers, and an aluminized outer coating to reflect heat. The aluminized coating may also impart some degree of protection by preventing or delaying the formation of urethane drippings on the floor which, if ignited, can contribute to the spread of fire (reference 10).

**Table 1. Materials Tested**

Material	Chemical Composition
<b>Baseline</b>	
(1) Wool (90%)/Nylon (10%) Fabric	—
(2) FR Urethane foam	—
<b>Foam Blocking Layer</b>	
(3) Vonar®, 3/16 in. thick	FR polychloroprene
(4) LS-200, 3/8 in. thick	FR polychloroprene
<b>Fabric Blocking Layer</b>	
(5) Norfab®, 13 oz/yd <sup>2</sup>	Blend of predominately aromatic polyamide fibers wrapped around a fiberglass fire core, aluminized outer surface.
(6) Preox®, 11 oz/yd <sup>2</sup>	Heat stabilized polyacrylonitrile, aluminized outer surface.
(1) Type of seat upholstery cover used in all tests	
(2) Fire-retardant	
(3) Registered Trademark, DuPont Co., Wilmington, Delaware	
(4) Product of Toyad Corporation, Latrobe, Pa.	
(5) Registered Trademark, Norfab Corporation, Norristown, Pa.	
(6) Registered Trademark, Gentex Corporation, Carbondale, Pa.	

## TEST ARTICLE

The test article was a C-133 aircraft, modified to resemble a wide-body cabin interior, as shown in figure 1 and in reference 11. The cross sectional area is similar to, although slightly smaller than, a wide-body cabin. An interior volume of 13,200 ft<sup>3</sup> is representative of a wide-body jet.

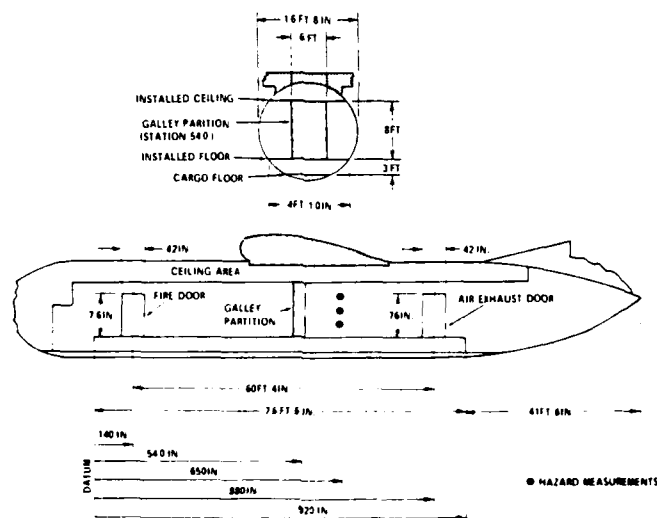
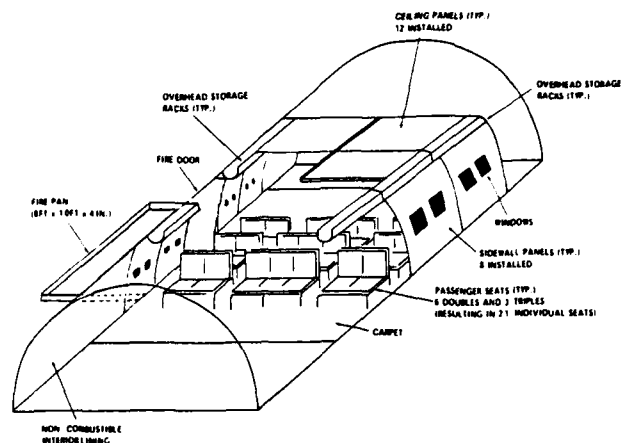

Figure 1. Schematic of C-133 Wide-Body Cabin Fire Test Article

All combustible materials installed in the original cargo aircraft were removed and the new floor, sidewall and ceiling surfaces are composed of noncombustible materials. A CO<sub>2</sub> total flooding system allows for the selective termination of a test. These protective measures have resulted in a durable test article, which has withstood hundreds of tests with only minor damage and thus allowed for the conduct of parametric studies with different materials or different fire test conditions.

The test article is extensively instrumented to measure the major hazards produced by a cabin fire as a function of time at various cabin locations. The following measurements are routinely taken: temperature, heat flux, smoke density, carbon dioxide (CO<sub>2</sub>), carbon monoxide (CO), oxygen (O<sub>2</sub>), acid gases (e.g., hydrogen fluoride (HF), hydrogen chloride (HCl)), and organic gases (e.g., hydrogen cyanide (HCN)). Video and photographic coverage documents the visual progress of the fire.

The C-133 test article was utilized to evaluate candidate blocking layer materials under test conditions representative of the three major types of cabin fires. Figure 2 illustrates the installation of interior materials in the forward part of the test article. The furnished test section is centered at the fuselage opening (test station 140) adjacent to an external fuel fire used in postcrash studies. For the postcrash test condition, an additional opening is provided at test station 880 (figure 1). A large fan behind the fire pan can be employed to simulate ambient wind and create penetration of fuel flames through the forward opening. Under both the ramp and in-flight test conditions, all fuselage openings are closed. For the in-flight condition, a ducting system was designed and installed in the test article to simulate ceiling air intake and baseboard air exhaust from a cabin environmental control system. One cabin air change occurs approximately every 3 minutes. No ventilation was used under the ramp fire condition.



**Figure 2. Installation of Wide-Body Materials Inside C-133 Test Article**

During some of the tests only aircraft seats were subjected to the fire conditions (e.g., ramp and in-flight tests). This was necessary because of the great expense of the ceiling and sidewall panel materials and stowage bins. The seating configuration was always centered at test station 140.

## IGNITION SOURCES

Table 2 lists the ignition sources used to evaluate the effectiveness of the candidate blocking layer materials. The plastic trash bag used in the ramp fire test was suggested by the 727 ramp fire discussed previously. Various ignition source intensities possible during an in-flight fire were employed, ranging from the relatively weak cigarette ignition to the more intense flight bag or gasoline fire. The burning flight bag ignition source, which was located underneath a seat, was also representative of floor burn through from a lower compartment. The most severe ignition source was the 80-square-foot fuel fire adjacent to a 76-inch by 42-inch fuselage opening, used to simulate a postcrash fire condition. Previous work had demonstrated that the intensity of the thermal radiation passing through an opening of this size was approximately 80 percent of the level produced by an infinitely large fuel fire under zero wind conditions (references 7 and 12).

**Table 2. Test Ignition Sources**

Type of Fire	Ignition Source
Ramp	<ul style="list-style-type: none"> <li>Plastic trash bag filled with approximately 18 ounces of paper towels and newspaper</li> </ul>
In-Flight	<ul style="list-style-type: none"> <li>Cigarette</li> <li>Newsprint (4 double sheets)</li> <li>Gasoline (1 pint)</li> <li>Simulated nylon flight bag (contents 2 shirts and 2 double sheets of newsprint approximately 22 ounces)</li> </ul>
Postcrash	<ul style="list-style-type: none"> <li>Jet fuel (80-square-foot pan containing 50 gallons of fuel)</li> </ul>

## TEST RESULTS

**RAMP FIRE** — In the ramp fire tests, three rows of triple aircraft seats, with each row containing two sets of triple seats and a section of carpet under the center row, were installed in the test article. The trash bag

was placed adjacent to an outer seat in the middle row and ignited with a match. Figure 3 compares results for a test with unprotected cushions and a test with cushions protected with an LS-200 blocking layer. The results demonstrated that the use of a foam blocking material on seat cushions can prevent a ramp fire which would become out of control in 3 to 5 minutes, if the seats were not protected.

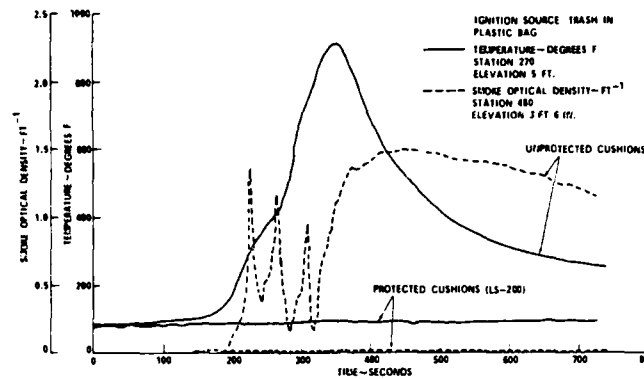

Figure 3. Seat Cushion Blocking Layer Benefit — Ramp Fire Scenario

Figure 3 indicates that the target seat became significantly involved in fire in about 3 to 3½ minutes. By almost 6 minutes oxygen depletion caused the flames to subside and the fire to transition to a smouldering stage, evidenced by the temperature peak and subsequent decrease in temperature and by the persistent increase in smoke level. Although not shown in the figure, the seats reignited into a flaming mode when a door to the test article was opened, because the supply of oxygen in the cabin was replenished. Eventually, all 6 sets of triple seats were consumed by fire.

**IN-FLIGHT FIRE (C-133)** — The in-flight fire test setup was identical to that used in the ramp fire tests with two exceptions: (1) simulated cabin air ventilation was employed, and (2) the ignition source was placed under (versus adjacent to) the target seat (same seat location). Figure 4 compares the temperature history slightly forward of the fire origin in tests with foam blocking layer protection, fabric blocking layer protection and no seat protection. Both types of blocking layer materials prevented a fire which would have spread uncontrollably without seat protection. Based on the peak temperatures, the foam blocking layer was more effective than the fabric blocking layer, although both types of material prevented fire spread beyond the vicinity of the ignition source.

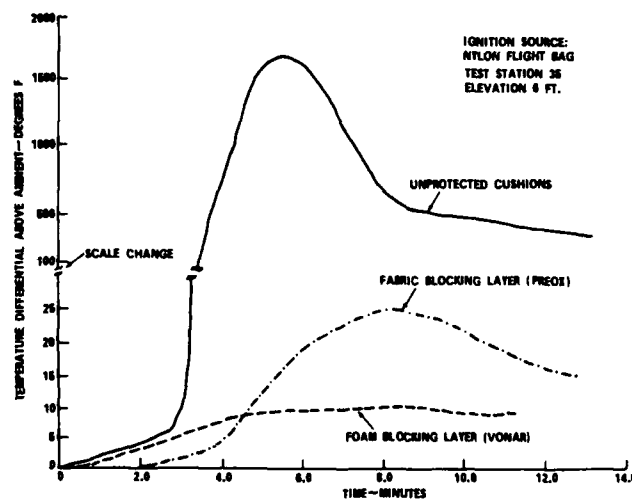

Figure 4. Seat Cushion Blocking Layer Benefit — In-flight Scenario

The ramp and in-flight test results were similar in terms of the time interval from ignition to a significant increase in cabin temperature — approximately 3 minutes in both cases. This finding was probably due to the weights of the ignition sources being nearly equivalent. However, the in-flight ignition source was observed to continue burning for a longer time than the ramp fire ignition source. From figure 4, it appears that the in-flight source fire persisted for 8 minutes, apparently because of the slower-burning clothing materials.

From a practical viewpoint, the time interval before significant seat involvement, without blocking layer protection, under most circumstances would be adequate for cabin crewmembers to extinguish the fire with hand-held extinguishers. Fires of this nature can be extinguished in 5 to 10 seconds under optimum firefighting conditions (e.g., immediate agent application, unobstructed access to base of fire, etc.). However, extenuating circumstances such as panic, or perhaps the fire origin being beneath the cabin floor, suggest the potential benefits of additional protection.

**EFFECT OF FLAME RETARDANT IN URETHANE** — In this period of unpredictable fuel costs, airplane operators continually strive for weight reduction. When a blocking layer material is employed, an increase in seat weight will be incurred. One method of minimizing the potential weight penalty of fire blocking layers is to utilize a nonfire-retardant (NF) urethane foam cushion, which is about 20 percent lighter than fire-retardant (FR) urethane foam. A series of tests were performed to determine if the use of a blocking layer over NF urethane foam presented any greater in-flight fire hazard than presently used FR urethane foam. Tests were also performed to study and compare the behavior of FR cushions with various blocking layers.

The tests were conducted in an open test bay area using a single aircraft triple seat (reference 13). The middle seat cushions were removed and the outer seats were configured in accordance to the comparison under study; e.g., in one test, both seats were protected with a foam blocking layer, but an NF foam was used in one seat and an FR foam in the other. For a given test, each seat was subjected to an identical ignition source. Figure 5 shows test results with newspaper ignition on the seat, with one seat comprised of an NF urethane foam protected with a fabric blocking layer and the other seat comprised of unprotected FR urethane foam. At 90 seconds, the protected seat had self-extinguished, while the unprotected seat fire was essentially out of control.

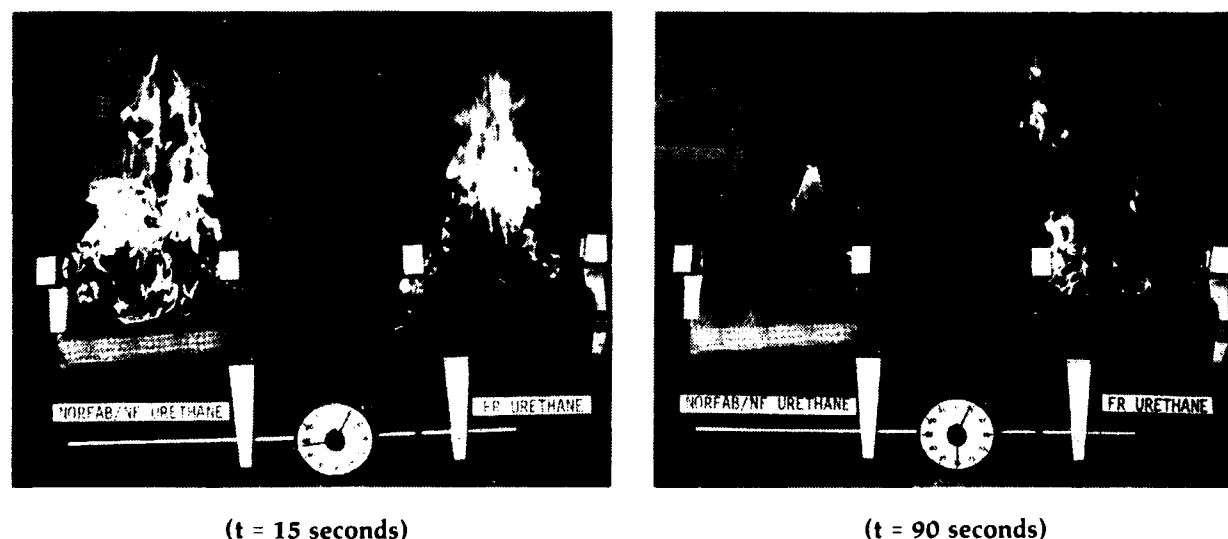

**Figure 5. Seat Performance Against Newspaper Fire**

Table 3 is a generalization of the in-flight ignition source results. It is apparent that either foam or fabric blocking layers over NF urethane cushions can prevent in-flight fires, which if left uncontrolled, can spread

beyond the ignition source when the cushion is simply FR urethane. Moreover, when a blocking layer material is utilized, the presence or not of fire retardants in the urethane foam cushion will not have a bearing on the ultimate result, which is self-extinguishment of the seat fire. During replicate tests with blocking layer materials, the time to self-extinguishment depended on whether other seat components (e.g., armrest, tray back) were ignited. If these components were not involved, the fire was essentially out after the ignition source was consumed. When the seat components became involved, the fire burned, appreciably longer before self-extinguishing. During this latter kind of behavior, the fire intensity and growth was subdued compared to the burning of an unprotected seat. Thus, blocking layer materials were effective even when seat components other than the cushions were ignited.

Table 3. Generalization of Small Ignition Source Results

Ignition Source	Blocking Layer Type				
	None	Foam		Fabric	
		Urethane Foam Treatment			
	FR	FR	NF	FR	NF
Cigarette	Self-Extinguished	Self-Extinguished	Self-Extinguished	Self-Extinguished	Self-Extinguished
Newspapers on Seat	Destroyed Seat	Self-Extinguished	Self-Extinguished	Self-Extinguished	Self-Extinguished
Newspapers under Seat	Destroyed Seat	Self-Extinguished	Self-Extinguished	Self-Extinguished	Self-Extinguished
Gasoline (1 pint)	Destroyed Seat	Self-Extinguished	Self-Extinguished	Self-Extinguished	Self-Extinguished

FR Fire-Retardant  
 NF Nonfire-Retardant

**POSTCRASH FIRE (FULL-SCALE TESTS)** — The postcrash fire tests were the most realistic undertaken. In these tests, a section of the C-133 test article was realistically lined and furnished with surplus or new wide-body materials, as illustrated in figure 2 and reference 7. The main objective was to examine the post-crash fire benefit of seat cushion blocking layer materials within the context of the remaining interior materials. The materials were subjected to a zero wind fuel fire adjacent to a large (22 ft<sup>2</sup>) fuselage opening. Prior testing had demonstrated that a zero wind condition would produce minimal cabin hazards from the fuel fire; therefore, any hazards detected with interior materials installed could be attributed to the burning materials. Four full-scale tests were conducted with the only variable being the cushion makeup. The following cushions were tested: (1) unprotected (FR urethane) cushion, (2) FR urethane cushion with foam (Vonar) blocking layer, (3) FR urethane cushion with fabric (Norfab®) blocking layer, and (4) noncombustible (ceramic fiber glass) cushion.

In each of the tests, the fuel fire ignited the interior and produced a condition called "flashover," which occurred at a different point in time in each test. Flashover corresponds to a rapid growth of the fire from an area in the immediate vicinity of the fuel fire to the remaining cabin interior.

Figure 6 is a set of photographs taken at 5-second intervals, evidencing the onset of flashover in the test with unprotected cushions. In a cabin fire, flashover seems to be caused by ignition of the hot smoke layer in the upper part of the cabin and of any materials nearby, leading to increased thermal radiation upon, and ignition of, materials in the lower cabin, and by burning ceiling panels which happen to fall upon and ignite seats.



(a) 2:05



(b) 2:10



(c) 2:15

**Figure 6. Photographic Documentation of Flashover**

In the C-133 test article, measurements are taken of what are believed to be the major fire hazards. Figure 7 contains these measurements as a function of time at an aft location for the test with unprotected cushions. Reference 7 contains an analysis which concludes that the various hazards are survivable before the onset of flashover, although widely accepted data does not exist for the incapacitation tolerance limits of the irritant gases HCl and HF. After flashover the various hazards increase markedly, and the analysis in reference 7 indicates that the tolerance limit is exceeded for five of the hazards. Thus, the occurrence of flashover indicates that conditions will rapidly become nonsurvivable throughout the cabin.

In order to quantitate the hypothetical survival time, a simple human survival model was developed which considers the effects of elevated temperature, CO<sub>2</sub>, CO, HCN, HF, and HCl (reference 7). The major assumptions were that the hazards are additive and that a classical hyperbolic relationship exists between gas concentration and time of incapacitation. The model is hypothetical, and was developed as a tool for reducing a number of somewhat abstract hazard measurements into a single, cogent parameter-survival time.

The model was applied to analyze the survivability associated with the four full-scale fire tests with different cushion makeups. In the model, a variable called the mixture fractional effective dose (FED) is

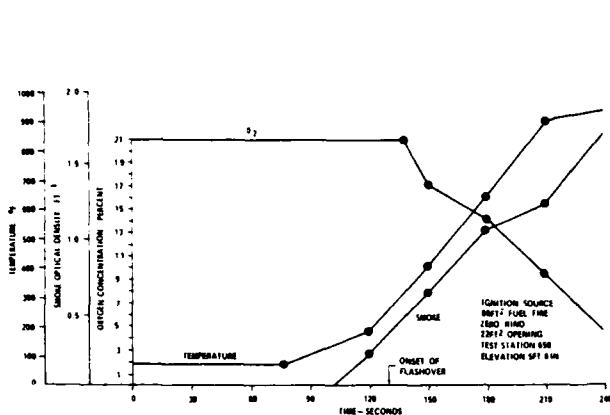

(a) During a Postcrash Fire

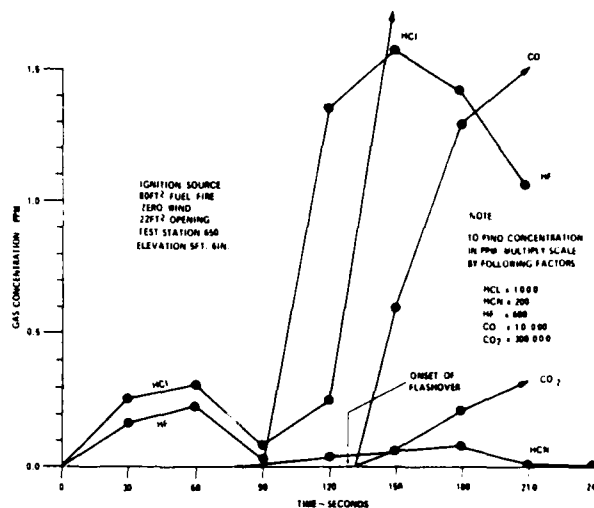

(b) During a Postcrash Fire

Figure 7. Hazards in Aft Cabin Produced by Burning Interior Materials

defined. It is calculated at each time increment analyzed, and is essentially the sum of the ratios for each hazard of measured dose to the incapacitation dose. Thus, the hypothetical survival time corresponds to that point in time when  $FED = 1.0$ .

Figure 8 is a plot of the calculated FED versus time in the aft cabin for the four full-scale fire tests. This plot indicates the safety benefit, in terms of increase in survival time, associated with seat blocking layer materials under the postcrash fire condition tested. The calculated FED does not include the effect of HCl in any of the tests because a malfunction in the analysis of HCl in one of the tests. The safety benefit of Vonar and Norfab blocking layer materials — 60 and 43 seconds, respectively — is considered significant, especially since the benefit is incurred within the context of the remaining interior materials. In addition, the results indicate that the amount of protection provided by Vonar is nearly equivalent to that of a noncombustible cushion, under the fire conditions studied. (note that the improvement in survival time with the noncombustible cushions was only 8 seconds better than with the Vonar protected cushions.) The shape of the FED profiles indicate to some degree the rapidity by which conditions become nonsurvivable after the onset of flashover. In fact, the calculated safety benefit (survival time increase) for each of the protected cushion tests corresponds to the increase in time before the onset of flashover relative to the unprotected cushion test. Figure 8 also indicates that  $FED = 0$  throughout the time framework of interest when the interior is noncombustible. This finding indicates that potential safety benefits exist, beyond that provided by seat blocking layers, by making improvements in the fire performance of other important interior materials; e.g., ceiling panels and overhead stowage bins.

Smoke was not a component of the human survival model. However, the impact of visibility obscuration resulting from smoke was calculated (reference 7). Figure 9 is a plot of cabin visibility in the aft cabin versus time for the four full-scale material tests. The most striking feature of the curves is the rapidity by which visibility becomes obscured, e.g., in some cases visibility was reduced from the length of the cabin to less than the width of the cabin in approximately 15 seconds. Also, by comparing figure 8 and 9, it is apparent that smoke becomes an important factor anywhere from 30 to 60 seconds before survival is no longer theoretically possible. This comparison also reveals that the ranking of results from best to worst for visibility loss was identical to the rankings for loss in survival time (i.e., noncombustible cushions > Vonar > Norfab > unprotected cushions).



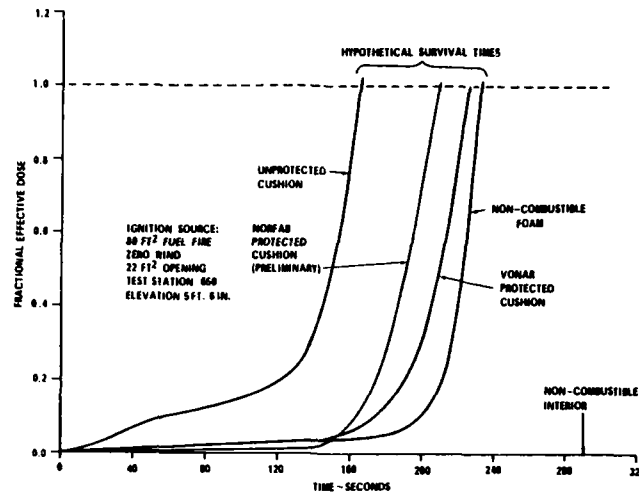

Figure 8. Effect of Cushioning Protection on Calculated Survival Time Under Full-Scale Postcrash Fire Conditions

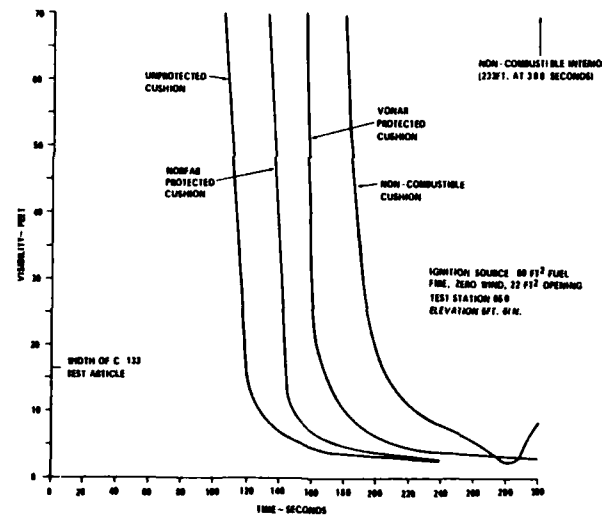

Figure 9. Effect of Cushioning Protection on Calculated Visibility Through Smoke Under Full-Scale Postcrash Fire Conditions

**POSTCRASH FIRE (OTHER SCENARIOS)** — The postcrash fire scenario discussed above was conceived for the purpose of creating a realistic impact-survivable fire situation wherein burning cabin materials have a dominant, if not controlling, effect on survivability. Obviously, a large number of other, and, perhaps more likely survivable postcrash fire conditions are possible. Another condition studied was a 2-foot-square opening, simulating a small fuselage rupture above the cabin floor, adjacent to the large external fuel fire. Because of the small rupture area, a simulated 3 miles per hour (mph) wind was utilized to intensify the cabin exposure conditions. Four double seats — three outboard and one inboard — symmetrically placed about the small rupture, were tested under these conditions. No other materials were placed in the test article. Figure 10 displays the cabin temperature history for three types of seating materials and for the fuel fire without seats. The results exhibit data crossover and small discrimination in the performance of different materials. For these reasons, this scenario was not utilized except for the above

tests. The data also demonstrates that wind conditions created significant fuel-fire hazards inside the cabin. Under the conditions tested, approximately 50 percent of the cabin hazards were caused by the fuel fire.

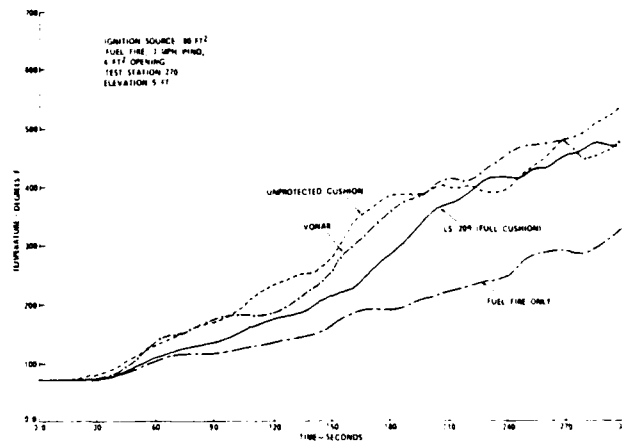

Figure 10. Postcrash Fire Test Results With Small Fuselage Opening and Wind

Another possible postcrash fire scenario consists of an intact fuselage with a door opening adjacent to a large external fuel fire. This scenario was also studied briefly, and is very similar to a past accident (reference 14). In these tests, a single triple outboard seat was located fore and aft of the type A door opening, and a 1.5 mph simulated wind was employed to create slight flame penetration into the cabin. Figure 11 compares temperature and smoke histories in tests with Vonar protected cushions and with unprotected cushions. In the test with protected cushions, the seat fire damage was minor and confined to the seat upholstery cover and various seat components; the flammable urethane foam did not become involved. By contrast, in the test with unprotected cushions, the fire became out of control in 3 to 4 minutes.

Thus, under this fire scenario, the benefit of seat cushion blocking layers is significant. An analysis of the results acquired for the three postcrash fire scenarios, as presented in figures 8, 10, and 11, demonstrate that potential benefits of seat cushion fire blocking layer materials are highly dependent upon fire scenario.

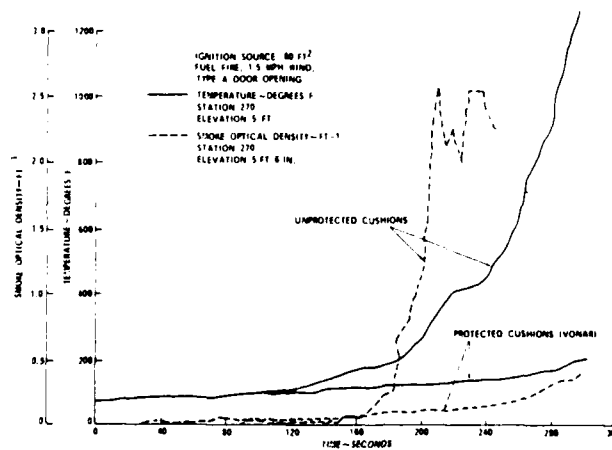

Figure 11. Seat Cushion Blocking Layer Benefit — Postcrash Fuel Fire Adjacent to Open Door

## SUMMARY OF SIGNIFICANT FINDINGS

Based on the realistic cabin fire tests and analysis described in this paper, and on the seat cushion blocking layer materials evaluated and the types of fire test conditions employed, the following are the significant findings:

(1) Seat cushion fire blocking layer materials such as neoprene foam or aluminized high-temperature fabrics can prevent ramp and in-flight fires which become out of control when initiated at an unprotected seat and left unattended.

(2) Seat cushion fire blocking layer materials can significantly increase the safe time available for evacuation during specific types of postcrash cabin fire scenarios.

(3) Under severe fire conditions, such as a postcrash fuel fire, neoprene foam materials are more effective seat cushion blocking layers than aluminized high-temperature fabrics.

(4) Fire-retardant urethane foam can be replaced by nonfire-retardant urethane foam in aircraft seat cushions covered with a blocking layer material without essentially any loss in in-flight fire protection.

## REFERENCES

1. "Fire Research on Cellular Plastics: The Final Report of the Products Research Committee," Library of Congress Catalog Card Number: 80-83306, April 1980.
2. "Final Report on the Special Aviation Fire and Explosion Reduction (SAFER) Advisory Committee," Federal Aviation Administration, Volume I, Report FAA-ASF-80-4, June 26, 1980.
3. "Bi-Monthly Fire Record," Fire Journal, Vol. 74, No. 2, p. 22, March 1980.
4. "Aircraft Accident Report: Saudi Arabian Airlines, Lockheed L-1011, HZ-AHK, Riyadh, Saudi Arabia, August 19, 1980," Presidency of Civil Aviation, Jeddah, Saudi Arabia, January 16, 1982.
5. "Special Study: U.S. Air Carrier Accidents Involving Fire, 1965 through 1974, and Factors Affecting the Statistics," National Transportation Safety Board, Report NTSB-AAS-77-1, February 17, 1977.
6. Eklund, T.I. and Sarkos, C.P., "The Thermal Impact of External Fuel Fires on Aircraft Fuselages, Journal of Fire and Flammability, Vol. II, pp. 231-240, July 1980.
7. Sarkos, C.P., Hill, R.G., and Howell, W.D., "The Development and Application of a Full-Scale Wide Body Test Article to Study the Behavior of Interior Materials During a Postcrash Fuel Fire," AGARD Lecture Series No. 123 on Aircraft Fire Safety, AGARD-LS-123, June 1982.
8. Morford, R.H., "The Flammability of Neoprene Cushioning Foam," Journal of Fire and Flammability, Vol. 8, pp 279-299, July 1977.
9. Kourtides, D.A. and Parker, J.A., "Test Methodology for Evaluation of Fireworthy Aircraft Seat Cushions," Journal of Fire and Flammability, Vol. 15, pp. 56-76, January 1982.
10. Schutter, K.J. and Duskin, F.E., "Study for the Optimization of Aircraft Seat Cushion Fire Blocking Layers - Full Scale - Test Description and Results," NASA Contractor Report, Contract NASA2-11905, Douglas Aircraft Company, Report No. MDC J2525, May 1982.
11. Hill, R.G., Johnson, G.R., and Sarkos, C.P., "Postcrash Fuel Fire Hazard Measurements in a Wide-Body Aircraft Cabin," Federal Aviation Administration, NAFEC, Report FAA-NA-79-42, December 1979.
12. Eklund, T.I., "Pool Fire Radiation through a Door in a Simulated Aircraft Fuselage," Federal Aviation Administration, NAFEC, Report FAA-RD-78-135, December 1978.
13. Hill, R.G., et al, "Aircraft Seat Fire Blocking Layers; Effectiveness and Benefits Under Various Fire Scenarios," Federal Aviation Administration, report to be published.
14. "Aircraft Accident Report: Continental Air Lines, Inc., McDonnell-Douglas DC-10-10, N68045, Los Angeles, California, March 1, 1978," National Transportation Safety Board, Report NTSB-AAR-79-1, January 25, 1979.

## ACKNOWLEDGEMENTS

The authors are grateful to the following individuals who made important contributions to this paper. Mr. Louis Brown directed the preparation and conduct of the C-133 fire tests. The work on the effect of foam treatment and blocking layer materials when seat cushions are subjected to in-flight ignition sources was performed by Mr. Lawrence Curran. Ms. Louis Speitel and Mr. Robert Filipczak devised and performed the difficult sampling and quantitative analysis of irritant and organic gases, respectively. Graphs and figures were skillfully prepared by Mr. George Johnson.

# TECHNICAL REPORTS AND PAPERS A SUMMARY OF FAA POSTCRASH CABIN FIRE SAFETY STUDIES

by  
Constantine P. Sarkos

## Fire Blocking Layers

1. Sarkos, C. P., and Hill, R. G., *Effectiveness of Seat Cushion Blocking Layer Materials Against Cabin Fires*, SAE Technical Paper No. 821484, presented at Aerospace Congress and Exposition, October 25-28, 1982.
2. Kourtidis, D. A., Parker, J. A., Ling, A. C., and Hovatter, W. R., *Optimization of Aircraft Seat Cushion Fire Blocking Layers*, Federal Aviation Administration, Report DOT/FAA/CT-82/132, March 1983.
3. Brown, L. J., and Johnson, R. M., *Correlation of Laboratory-Scale Fire Test Methods for Seat Blocking Layer Materials with Large-Scale Test Results*, Federal Aviation Administration, Report DOT/FAA/CT-83/29
4. Hill, R. G., Brown, L. J., Speitel, L., Johnson, G. R., and Sarkos, C. P., *Aircraft Seat Fire Blocking Layers: Effectiveness and Benefits Under Various Scenarios*, Federal Aviation Administration, Report DOT/FAA/CT-83/43, February 1984.
5. Hall, J. R., and Steifel, W. W., *Decision Analysis Model for Passenger-Aircraft Fire Safety with Application to Fire Blocking of Seats*, Federal Aviation Administration, Report DOT/FAA/CT-84/8, April 1984.

## Improved Fire Test Methods for Interior Materials

1. Nicholas, E. B., *Evaluation of Existing Flammability Test Methods by Comparison of the Flammability Characteristics of Interior Materials*, Federal Aviation Administration, Report FAA-NA-79-46, March 1980.
2. Spieth, H. H., Gaume, J. G., Luoto, R. E., and Klinck, D. M., *A Combined Hazard Index Fire Test Methodology for Aircraft Cabin Materials — Volume I and II*, Federal Aviation Administration, Report DOT/FAA/CT-82/36 — I and II, April 1982.
3. Sarkos, C. P., Hill, R. G., and Howell, W. D., *The Development and Application of a Full-Scale Wide Body Test Article to Study the Behavior of Interior Materials During a Postcrash Fuel Fire*, AGARD Lecture Series No. 123 on Aircraft Fire Safety, AGARD-LS-123, June 1982.
4. Quintiere, J. G., *An Assessment of Correlations Between Laboratory and Full-Scale Experiments for the FAA Aircraft Fire Safety Program, Part 1: Smoke*, National Bureau of Standards, Report NBSIR 82-2508, July 1982.
5. Quintiere, J. G., *An Assessment of Correlations Between Laboratory and Full-Scale Experiments for the FAA Aircraft Fire Safety Program, Part 2: Rate of Energy Release in Fire*, National Bureau of Standards, Report NBSIR 82-2536, July 1982.
6. Parker, W. J., *An Assessment of Correlations Between Laboratory and Full-Scale Experiments for the FAA Aircraft Fire Safety Program, Part 3: ASTM E 84*, National Bureau of Standards, Report NBSIR 82-2564, August 1982.
7. Quintiere, J. G., *An Assessment of Correlations Between Laboratory and Full-Scale Experiments for the FAA Aircraft Fire Safety Program, Part 4: Flammability Tests*, National Bureau of Standards, Report NBSIR 82-2525, July 1982.
8. Quintiere, J. G., and Tanaka, T., *An Assessment of Correlations Between Laboratory and Full-Scale Experiments for the FAA Aircraft Fire Safety Program, Part 5: Some Analyses of the Postcrash Fire Scenario*, National Bureau of Standards, Report NBSIR 82-2537, July 1982.
9. Parker, W. J., *An Assessment of Correlations Between Laboratory and Full-Scale Experiments for the FAA Aircraft Fire Safety Program, Part 6: Reduced-Scale Modeling of Compartments at Atmospheric Pressure*, National Bureau of Standards, Report NBSIR 82-2598, March 1983.

10. Harkleroad, M., Quintiere, J. G., and Walton, W., *Radiative Ignition and Oxygen Fuel Equivalence Measurements on Materials*, Federal Aviation Administration, Report DOT/FAA/CT-83-28, August 1983.
11. Eklund, T. I., *Quasi-Steady Analysis of Aircraft Panel Flammability*, Federal Aviation Administration, Report DOT/FAA/CT-84/14, June 1984.
12. Sarkos, C. P., Filipczak, R. A., and Abramowitz, A., *Preliminary Evaluation of an Improved Fire Test Method for Aircraft Materials*, Federal Aviation Administration, Report DOT/FAA/CT-84-22, December 1984.
13. Sarkos, C. P., and Hill, R. G., *Evaluation of Aircraft Interior Panels Under Full Scale Cabin Fire Conditions*, paper to be presented at AIAA 23rd Aerospace Sciences Meeting, January 14-17, 1985, Reno, Nevada.
14. Quintiere, J. G., Harkleroad, M., and Hasemi, Y., *Wall Flames and Implications to Aircraft Cabin Seating*, in preparation.
15. Quintiere, J. G., Babrauskas, V., Cooper, L., Harkleroad, M., Steckler, K., and Tewarson, A., *Flaming Aircraft Panel Materials in Cabin Fires and Their Properties*, in preparation.
16. Sarkos, C. P., Hill, R. G., Eklund, T. I., and Filipczak, R. A., *Development of an Improved Fire Test Method for Aircraft Interior Materials*, in preparation.

### Improved Emergency Lighting

1. Chesterfield, B. P., Rasmussen, P. G., and Dillon, R. D., *Emergency Cabin Lighting Installations: An Analysis of Ceiling vs Lower-Cabin-Mounted Lighting During Evacuation Trials*, FAA Office of Aviation Medicine Report No. FAA-AM-81-7, February 1981.
2. Demaree, J., *Examination of Aircraft Interior Emergency Lighting in a Postcrash Fire Environment*, Federal Aviation Administration, FAA Technical Center, Report DOT/FAA/CT-82/55, June 1982.
3. Teal, M., *Improved Interior Emergency Lighting Study*, Federal Aviation Administration, Report DOT/FAA/CT-83/31, September 1983.

### Heat Resistant Evacuation Slides

1. Cole, R., and Sims, G., *Aluminized Coating Study for Retrofitting Inservice Slide Materials*, Federal Aviation Administration, Report No. FAA-CT-81-151, November 1980.
2. *Symposium on New Safety Considerations for Emergency Evacuation Slides, October 28-29, 1980*, Federal Aviation Administration, Report No. FAA-CT-81-163, December 1980.
3. Brown, L. J., and Nicholas, E. B., *Effect of Thermal Radiation on the Integrity of Pressurized Aircraft — Evacuation Slides and Slide Materials*, Federal Aviation Administration, Technical Center, Report FAA-CT-81-28, March 1981.

## SESSION V

### EVACUATION AND SURVIVAL



**Panel Moderator**

**Hector Barrera**

**Manager, Flight Attendant Training and  
Procedures Department Frontier Airlines**

Mr. Barrera earned his B.A. Degree from St. Mary's College of Missouri in 1975. He started his career with Frontier Airlines as a Flight Attendant. He served as a Flight Attendant Training Instructor prior to assuming his present position as Manager of the Flight Attendant Training and Procedures Department.

He is a member of the Frontier Association of Flight Attendants' Air Safety Committee, a member of the Corporate Safety Committee, and a Representative to the ATA Cabin Operations Committee.

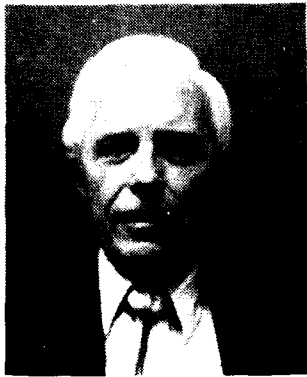

**Paul G. Rasmussen**  
**Supervisor, Evacuation Research Unit**  
**FAA Civil Aeromedical Institute**

Paul received his Bachelor's Degree in Psychology from Miami University of Ohio in 1958 and his Masters in Industrial Management from the University of Oklahoma in 1966.

He began his career at Wisconsin General Hospital as a Research Associate. He later worked for the General Electric Company as a Human Engineering Specialist and as a Human Factors Specialist.

He joined the FAA Civil Aeromedical Institute in 1968 as a Research Physiologist in their Aviation Physiology Laboratory.

He is presently the Supervisor of the Evacuation Research Unit in their Protection and Survival Laboratory.



## CONFIGURATIONAL FACTORS: EMERGENCY EGRESS, TECHNIQUES AND AIDS

Paul G. Rasmussen

Emergency evacuation is a complex subject matter involving many interacting elements. For the purpose of simplicity the broad topic has been divided into several narrower areas of consideration. It is difficult to specify where one area of emphasis overlaps another, but I will attempt to limit myself to the configurational factors which are essentially those associated with the physical environment, either as originally constructed, or as altered by accidental circumstances. I hope that the other speakers will forgive me if I lose sight of this distinction and occasionally stray into their topics.

It has only been in the last thirty years or so that emergency evacuation has become a major consideration in the broader area of passenger safety. Prior to this time the passengers' survival in an accident of any significant severity seems, at least in retrospect, to have been pretty much a matter of chance that we had little ability to influence. What began to dictate the need for effective means of emergency evacuation were the rapid advances in crashworthiness that were being made in airframe design. With the advent of better aircraft structures and other technology, we began to experience an increasing number of accidents where passengers survived the crash impact or other threat, only to see an increasing number of fatalities as the result of post crash fire. The urgency of the problem grew in approximately direct proportion to the growing size and complexity of modern aircraft, the number of aircraft operated in passenger service, and the rapidly rising number of passengers carried each year.

A modern airliner possesses some unique characteristics that are not common to other public facilities. It generally has a higher occupancy density than any fire marshall would permit for a fixed structure with comparable floor space. It has no fixed fire escape and therefore cannot be evacuated while being operated in its intended manner. It has sophisticated fire-extinguishing systems, but no handy fire hydrant. It has several exits but they differ in their sizes and manner of use from those we encounter elsewhere and may more readily be rendered inoperative by structural damage. And there are tons of flammable fluids stored in close proximity to the occupants. In its element, the modern airliner must be completely self-sustained for the duration of the flight. It is these and numerous other characteristics that dictate the need for special safety requirements to minimize the risk to passengers and crew when an immediate or potential threat arises.

As varied as the interiors of various aircraft may be, they share a great number of common features. Aside from purely functional considerations, the basic configurational design is heavily influenced by the requirements of the Federal Aviation Regulations (FARs). Part 25 specifies, among other things, the type, minimum number, minimum size, general location, and accessibility of exits for various seating capacities. The most commonly required exits for cabins with large seating capacities are Type I with minimal dimensions of 24 by 48 inches, Type III with minimal dimensions of 20 by 36 inches, and Type A with minimal dimensions of 42 by 72 inches. Type I and Type A exits are floor level exits and Type III are commonly used for over-the-wing exits. Oversized Type I exits up to 34 by 72 inches are sometimes provided and have the advantage of facilitating the preferred 'jump-and-slide' method of egress when using evacuation slides.

Also specified are the requirements for evacuation assisting means such as inflatable, self-erecting evacuation slides, minimum aisle width, maximum number of seats abreast to reach the aisle, minimum levels of general emergency lighting, and the size, brightness, and location of exit locators and exit identifiers. These requirements are generally adequate to provide for effective passenger evacuation except under the most adverse conditions. However, the emergency lighting requirements have occasionally proven to be less than adequate when dense smoke was present in the cabin. I will discuss this problem in a practical context later in this presentation.

Meeting these minimum requirements does not assure that the aircraft will be certified for passenger service. The manufacturer, or an operator making significant changes to the originally certified configuration, must prove by actual demonstration that a full complement of passengers and crew can be evacuated to the ground within 90 seconds. These certification demonstrations are conducted under actual or simulated nighttime conditions using only the installed emergency lighting and half of the installed exits.

There are other requirements for the conduct of these demonstrations but rather than reciting them here I will refer you to FAR 25.803 for more complete details.

Just how effective are these evacuation related safety requirements? It is difficult to say. Approximately 80% of the more than 900 fatalities in U.S. airline accidents involving fires since 1965 were directly caused by fire or its related effects because the passengers could not evacuate the involved aircraft. There are no figures that can give us a reliable estimate of how many passengers actually survived because of the provisions made for emergency evacuations, but we have an indication of the number of passengers and crew who can be considered to have been at some risk during recent years. The Civil Aeromedical Institute (CAMI) Cabin Safety Data Bank contains information on a total of 85 evacuations during the five year period 1978 through 1982. These evacuations involved in excess of 7100 passengers and crew. Even though these numbers are relatively small in view of the number of flights undertaken, and the number of passengers carried, they make it obvious that emergency evacuations can play a significant role in maintaining passenger safety.

By far the greatest number of evacuations initiated during operations are precautionary in nature and are conducted under relatively favorable conditions. I say 'relatively' because there are no truly ideal conditions. It is an unfamiliar activity conducted in unique surroundings with which the flying public has little or no practical experience, other than as passive observers, and for which they can never be fully prepared. However, when there is little or no structural damage to an aircraft, and there is no smoke or fire in the passenger cabin, and no significant fire in the immediate exterior area of the aircraft, an evacuation can generally be accomplished in a rapid and relatively safe manner.

Even under these conditions, minor injuries frequently result from such evacuations. Cuts, bumps, bruises, sprains, and comparable injuries occur not only in actual evacuations but also in the much more closely controlled environment of certification demonstrations and evacuations conducted in a research environment. Serious injuries, including broken bones, are relatively rare under these circumstances but still occur with a greater frequency than we would like to see.

If an aircraft comes to rest with significant structural damage the configurational factors can change drastically. Such damage and exterior conditions may limit the number and location of usable exits. Access to exits may also be hindered by disruptions to the interior of the cabin such as broken seat assemblies, dislodged cabin furnishings, and other debris, including carry-on luggage. Damage to, or the loss of, the undercarriage frequently imposes a combination of pitch, roll, and yaw on the floor surface that can adversely affect the passengers' spatial orientation and impede their physical movement through the cabin. An unusual aircraft cabin attitude can also alter the distance from the exit thresholds to ground level with a resulting change in the deployment angles of the evacuation slides. A slide deployed at a steeper angle than it was designed for, as would be encountered if the exit threshold is higher than normal, will result in a faster but less controlled, and therefore more dangerous descent. Less steeply deployed slides can actually slow the evacuation rate because the evacuating passengers may find themselves stopped about half way down the slides and find it difficult to gain solid footing and maneuver themselves away from the aircraft.

It is more difficult to assess evacuation related injuries when there has been a significant impact. Accident reports frequently fail to specify if an injury was sustained from the original impact or from subsequent evacuation activity. The CAMI Cabin Safety Data Bank lists 48 evacuations during the five year period 1975 to 1979 for which no prior injuries were reported but which resulted in evacuation related injuries. These evacuations were conducted under conditions ranging from bomb threats that involved no aircraft damage or malfunctions to those involving significant structural damage and, in some instances, fires of varying size and intensity. Of the 6012 passengers and crew aboard, 360 suffered minor injuries, 78 suffered major injuries, and there were two fatalities. The fatalities resulted from a fuel fire in the exterior evacuation area. There were six instances of aggravation of existing medical problems. The serious evacuation related injuries tended to be associated with falls from the wings when using the over-wing exits and falls from evacuation slides. It is reasonable to assume that injuries incurred prior to the initiation of an evacuation will not only slow the evacuation rate but that such injuries may be aggravated by the evacuation activity. It becomes a situation of exposing passengers to what is hopefully a lesser risk than would be incurred by remaining in or near the aircraft.

The most difficult conditions under which an evacuation will be required are encountered when there is fire and/or smoke in the passenger cabin. Fortunately, these instances are quite rare, but when they do occur, every element of the evacuation process becomes critical. The toxic properties of the smoke, heat, and the possibility of the phenomenon known as flash-over can reduce the difference between life and death to a matter of seconds.

Smoke, whether generated by an interior fire, or introduced from an exterior source such as a fuel fire, will behave pretty much as it does in any other enclosed space. It will tend to concentrate most heavily in the upper third of the cabin and can easily be dense enough to obliterate the general emergency lighting and the emergency exit signs while conditions in the lower part of the cabin are still survivable. I will remind you, however, that the smoke will not restrict itself solely to the upper part of the cabin. The distribution of smoke densities correlates fairly well with the temperature gradient through the lower two thirds of the cabin. It is not impossible to encounter smoke with an optical density of 0.5 per foot at mid-height while temperatures in the lower part of the cabin are still within short term survivable limits.

When smoke has an optical density of 0.5 we will have a total optical density of 2.0 over a four foot distance. This total density would permit only 1% of the light emitted by a source to reach the eyes of an observer at that viewing distance. At a six foot distance the total optical density would be 3.0, but because the density scale is logarithmic, only 1/10 of one percent of the emitted light would be discernible by an observer. In the context of an aircraft cabin this means that at a distance of six feet, which is approximately the distance from the center of the aisle to the cabin side-wall across three seats, you would just barely be able to discern the legend on the exit signs commonly found in many passenger cabins if all other viewing conditions were favorable. Under the adverse conditions of an evacuation involving dense smoke in the cabin, conventional exit signs, especially when mounted in the upper part of the cabin, are rarely visible at any useful viewing distance.

The loss of visual reference resulting from the shrouding smoke can seriously compromise the passengers' orientation to, and movement toward, an available exit at a time when speed and positive movement are most critical. The smoke not only blocks light but shrouds otherwise obvious physical features of the environment. There have been reported cases of passengers actually moving past open and available exits they could not see because of the smoke. Add these conditions to those described earlier involving structural damage and unusual attitudes and you have the worst imaginable conditions for an effective evacuation.

There are no known practical solutions to providing adequate illumination when very dense smoke is present in the vicinity of the source of the illumination. In developing solutions for improving visibility, care must be taken that the solution doesn't introduce other potentially serious problems. For example, the introduction of extremely bright sources of interior illumination is generally not effective in very dense smoke but may offer some advantage in less dense smoke. Very bright light sources, if not completely blocked by the smoke, may simply illuminate the smoke without improving the general visibility of the immediate environment. They may also prove blindingly bright when used in the absence of smoke. A generally good rule of thumb to follow is to use many smaller sources spaced close together rather than a few very bright sources spaced farther apart. Another good rule is to keep it as simple and familiar as possible. Complex systems of cascading or sequential lighting and high intensity strobe lighting can create confusion and ambiguity when and where it is least tolerable.

One solution to improving general emergency illumination and the visibility of exit signs is to position the signs and sources of illumination in the lower part of the cabin where the smoke is least dense. Experiments conducted at CAMI using lighting systems located at and below armrest level, and exit signs located at or below the mid-height of the cabin, resulted in a 20% faster evacuation rate from a smoke obscured cabin than when the signs and source of general emergency lighting were located in the upper part of the cabin.

Based in part on these results, as well as analysis of accident reports, it was recently announced in the Federal Register that the FAA has adopted a rule, effective November 26th of this year, that will require new standards for the provision of a floor proximity escape path marking system that will provide emergency evacuation guidance for passengers when all sources of illumination more than 4 feet above the cabin aisle floor are totally obscured. The marking system must permit passengers to readily identify each

exit from the emergency escape path by reference only to markings and visual features not more than 4 feet above the cabin floor. Though such a system is not required to function as a means for providing primary general emergency lighting, it will, if properly implemented, provide more positive passenger guidance than is presently available when the upper cabin is shrouded with smoke.

There is a constant effort to find new ways to improve the odds of survival for those passengers who find themselves at risk. In the Evacuation Research Unit at CAMI we are presently undertaking a program to evaluate the application of new and/or significantly improved lighting technology for possible applications to cabin safety. Special emphasis is being placed on effective means of implementing the floor proximity escape path marking system. We will be looking not only at the traditional incandescent and fluorescent lamp systems but also at systems based on light emitting diodes and the new high intensity electroluminescent lamps that have given some preliminary indications of providing better smoke penetration than has been achieved with traditional systems. In addition to lighting systems we also plan to evaluate an electronically synthesized voice system for possible application as an exit locating aid if a proposed system becomes available to us. It has also been suggested that some system of tactile cues might be useful as a means for providing location and guidance information when other means are rendered ineffective. I personally believe such an approach offers only limited possibilities but if a promising system becomes available we will definitely be interested in evaluating it.

At this point I would like to invite you to participate in this ongoing process. Inputs from the public at large, as well as the aviation and related industries, are always welcome. We particularly appreciate creative and practical suggestions that have direct application for improving the safety and effectiveness of emergency evacuation. I would ask you to remember, however, that the Civil Aeromedical Institute's Research Branch is not part of the regulatory process and we have no authority to require the implementation of any proposed changes in equipment or procedures.

In closing I would like to make the comment that no matter how many engineering solutions we devise to improve cabin safety in general, and emergency evacuations in particular, the value of what is implemented will be minimal unless airline passengers can be more positively engaged in an active role and responsibility for those aspects of their own safety over which they have some control. I take it, for instance, that most of you are seasoned air travelers. Yet, let me ask: "How many of you bother to notice the exits as you move along the aisle to your seat? How many of you pay attention to every passenger briefing and bother to study the passenger information card as requested? And how many of you make the effort to count the number of seat rows you would have to pass to reach the nearest exits fore and aft of your own seat row if you had to find an exit you couldn't see?" Conscious awareness and familiarity with the configuration of your environment and the limitations it may impose, as well as the safety features it provides, whether it be in your home, a car, a hotel, your workplace, or an aircraft passenger cabin, give you a significant safety advantage over those who passively consign themselves to chance fate or to being somebody else's responsibility.

Thank you.



**Capt. Roger Brooks**  
**Chairman, ALPA Accident Survival Technical Committee**

Mr. Brooks is a pilot with Frontier Airlines. He is a graduate of Arizona State University and has been a pilot for 20 years. In addition to airline flying, he is experienced in Corporate, Commuter Airline and Bush Pilot Operations.

Mr. Brooks is Chairman of the ALPA Accident Survival Technical Committee.

# EVACUATION TRAINING AND PROCEDURES

Roger Brooks

Good morning ladies and gentlemen, welcome aboard. Please listen to the following safety briefing as your life may depend upon this information. Place heavy carry-on items under the seat in front of you and observe the weight limitation of the overhead compartments. These compartments, like your seats, are not stressed to withstand survivable impact loads. Please don't put anything up there you don't wish to wear. To fasten your seatbelt, simply put the buckle in the holder. To unfasten, lift up on the release. Wear your seatbelt low and tightly about you for takeoff and landing. Your seat must be in the upright position with the tray table stowed for taxi, takeoff and landing to prevent injury and to facilitate escape in the event of a crash. This aircraft is equipped with 4 emergency exit doors and 2 over wing exits. The safety card found in the seat pocket in front of you will explain their operation. Please take a moment to find the exit nearest you. Now locate another exit to use as an alternate. In the event of an evacuation, go to the closest exit or proceed as directed by a crewmember. If you see or smell smoke, stay low to avoid breathing very hot air or toxic substances. As you leave your seat, assist your seatmates as necessary as yours may be the only assistance they receive. Once outside the aircraft, move far away and stay in groups. In the unlikely event of a sudden loss of pressurization, a mask will appear in front of you. Grasp the mask and pull the chord taunt to begin the flow of oxygen. If you are traveling with a small child, place your mask on first to preserve your consciousness before you assist your child. You should expect no assistance from your cabin crew until the aircraft has descended to a low altitude. There is a life jacket stowed in the seatback in front of you. In the event of a water landing, your seat bottom cushion may also be used as a flotation device. You will observe the "no smoking" and "fasten seatbelt" signs. Smoking is not permitted in the lavatories as it is a fire hazard. Please refer to the card in the seat pocket in front of you for further information. I now invite you to sit back, relax, keep your feet off the seats and enjoy your flight on Honest Airlines.

In their passenger briefing, Honest Airlines is educating and preparing their passengers to a greater degree than their competitors. Their concern for safety is also evident in their crew training. This airline recognizes that while crew emergency training and procedures are fairly standardized throughout the industry, there is no standardized accident scenario. Each emergency has its' own unique factors and crews must be trained to adapt to the situation at hand.

Let us now review Honest's crew training and see how it compares to our airlines. A good place to start is with the pilot and flight attendant manuals. Honest understands that crew response to an emergency situation is a team effort. Cooperation and coordination is emphasized to both flight deck and cabin personnel. Pilot and flight attendant manuals are periodically reviewed to confirm that non-conflicting if not identical information is provided in both manuals. The manuals contain information on the duties and responsibilities of the other team members. These manuals are also reviewed to insure that they reflect the current fleet mix of aircraft and any changes in on-board equipment.

This airline, like many others, gives their Captains instruction on leadership techniques and resource management. It is pointed out that 95% of their aircraft is located behind the cockpit door and the trained cabin crew members are resources available to the Captain. All pilots are told that with a pending emergency, the cabin crew must know the following: 1) The nature of the emergency. 2) The time available to prepare the cabin. 3) The signal to be used to signify taking the brace position. As well as a specific brace signal, Honest also has a signal to indicate if a flight attendant is needed in the cockpit immediately and one to tell the Captain that the cabin is not ready for take-off. Honest's fleet is equipped with evacuation alarms to preclude any misunderstanding as whether to evacuate. This also makes it abundantly clear that an evacuation is taking place. As the cockpit section is usually the first to arrive at the scene of an accident, flight attendants are told that evacuation assistance from the flight deck may not be available. Additionally, the pilots have very important functions to accomplish in the cockpit prior to their passenger evacuation duties. A pilot's evacuation checklist from one of their two-man airplanes is used to illustrate these cockpit tasks. I repeat it here for the benefit of this group:

Engines Shutdown .....	Start levers off
Standby Power Switch .....	Battery

Tower/Flight Attendants .....	Notify
Parking Brakes .....	Set
Flap Lever .....	40 Degrees
Speedbrake Lever .....	Down Detent
Pressurization Mode Selector .....	Manual DC
Outflow Valve Control Switch .....	Open
APU and Engine Fire Switches .....	Pull
Fire Bottles .....	Discharge
Emergency Exit Lights .....	On
Battery Switch .....	Off

The above functions take precedence to any cabin duties and the accomplishment of these functions can affect the whole viability of the evacuation process. Evacuation and over water recurrent training is a joint pilot and flight attendant exercise emphasizing teamwork.

Crews are taught that even with moderate "G" forces, overhead bins may open or fail. Seats may break loose and exits jam. The cabin you work in may not resemble the one you evacuate. If the aircraft has a moderate or greater passenger load, it may take more than 90 seconds to conduct the evacuation. Complications such as an unusual fuselage attitude, a water landing, darkness, smoke and fire will substantially increase the evacuation time. The danger of a post crash fire is emphasized. It is explained that many more people die of asphyxiation from smoke inhalation than from the fire itself. As well as being toxic, the smoke from an active fire is very hot and one breath can easily sear one's lungs and result in death.

The response sequence of the fire department, medical teams, police and other support groups is explained. A brief description of how fire trucks will deploy and how they will extinguish any fire is given. It is explained that foam is used to cover fuel and prevent or extinguish a fire by providing a chemical film cover which separates fuel from the air. Crews are taught that foam is not dangerous in any way, does not smell and is no more slippery than water. Foam may save their life.

Honest flies into several small cities where airport services are limited. A few of these airports have a part time tower with scheduled flights arriving after tower closure. Agents are glad that they received basic training in first aid, fire fighting and rescue techniques. They realize how important they and their training will be if one of their flights gets in trouble. When the tower is closed, an agent dutifully watches the flight approach and land. Crews and agents are aware that just knowing a flight has crashed does not mean that rescue services will be immediately available. The same fog that contributed to the crash will contribute to the delay in locating the accident site. Nor is it assured that when the aircraft is in sight, that fire and rescue equipment will be able to reach it. Soft ground, mud, tidal areas, deep snow, hills, gullies, lakes and wooded areas will complicate and delay CFR and medical response.

Even though Honest Airlines is a U.S. domestic carrier, they carry life vests for every passenger seat and for all crew members. Flight Operations is well aware that 31 of the country's 215 air carrier airports having significant nearby bodies of water are on their route system and they insisted that life vests be installed. Crews are reminded that a jet transport is not likely to float very long. Hypothermia is a problem in any water landing with cold water rescue times being very short. Water survival techniques are reviewed in training.

When an airliner is parked at its gate, the crew and passengers are in a relaxed state and there is no apparent danger. One activity that goes on almost every time the plane parks is fueling. Thousands of gallons or even tens of thousands of gallons of jet fuel are transferred into the aircraft at pumping rates up to 300 gallons per minute. While fires during fueling activities are rare, fuel spills are not. Honest operates one aircraft type that is notorious for spilling fuel out of tank vent lines. Any rupture of a high pressure hose or a loose fitting could quickly result in a large spill. Company policy is that the main entrance door must remain open during fuel operations with the jetway mated or the airstair deployed. Honest encourages safety improvements at the airports it serves. They also promote and participate in each airports' disaster drills.

It's obvious that Honest Airlines is a pretty sharp outfit. They strive for uniformly high quality in all their operations. The holding of an Air Carrier Operating Certificate allows them to sell tickets and transport

passengers. Being a publicly owned corporation operating in a free market, management has a fiduciary responsibility to the stockholders. Like any corporation, they seek not only profitability, but actively attempt to maximize earnings.

Honest management recognizes one other corporate obligation and goal... the safe transportation of its' passengers. Corporate philosophy dictates a conscious, continuous safety awareness. Sometimes non-required expenses are incurred such as the purchase of life vests. However, Honest, for the most part, accomplishes its safety goals just by having well trained and thorough employees and managers who are familiar with top management's concern for safety matters. My airline competes with Honest. So does yours. The fares are the same. Through this conference and workshop, let's strive to compete in quality as well.





**Charles R. Crane**  
**Supervisor, Aviation Toxicology Laboratory**  
**FAA Civil Aeromedical Institute**

Dr. Crane received his Ph.D. in Biochemistry from Florida State University in 1956.

After serving in various capacities in the academic field at Oklahoma University, Oklahoma State University and Florida State University, he joined the FAA Civil Aeromedical Institute in 1970 where he is now a Supervisor in their Biochemistry Research Unit.

Dr. Crane has authored and assisted in authoring numerous technical reports on biochemistry.

He is a member of the CAMI Library Committee and the FAA Chemical-Biological Warfare Defense Readiness Team.

He served as Chairman of the Toxicology group of the FAA/Industry Special Aviation Fire and Explosion Reduction (SAFER) Advisory Committee.

# HUMAN TOLERANCE TO TOXIC COMPONENTS OF SMOKE

Charles R. Crane

The Biochemistry Research group of the FAA's Aviation Toxicology Laboratory has been concerned since 1971 with the inhalation toxicology of combustion products, especially in the context of human survival in the environment of an aircraft fire.

Our resources are minimal, I have three people in my group, and our facilities are limited, yet by interacting with other FAA elements and with concerned scientists in other laboratories, significant contributions to the fundamental knowledge of this fledgling 'art' have been possible. Combustion toxicology may yet become a predictive, quantitative science.

I would like now to present a very condensed summary of where I think we stand today with regard to human tolerances to toxic components of smoke — along with some feeling for how we arrived there.

It is only within the last five or so years that most people, professional and layman alike, have become aware that over 80% of all fire fatalities are due directly to the inhalation of toxic gases (smoke, if you please), and not to thermal injury. Most fire victims are burned only after having been overcome (incapacitated or killed) by toxicity. Many victims, however, receive no thermal injuries whatsoever; once they have inhaled a quantity of toxic smoke sufficient to incapacitate them (prevent them from effecting their own escape), they collapse but continue to breathe the smoke until they have acquired a fatal dose.

It was exactly this sequence of events that led us to propose, over 10 years ago, that the toxicological endpoint with the most relevance to fire safety was physical incapacitation (loss of one's ability to escape the fire environment). Furthermore, it seemed to us that the most meaningful expression of relative hazard of smoke from different materials was a comparison of the total time one could breathe each smoke before losing that ability to escape. Therefore, all of our work has emphasized — for the first time in the field of inhalation toxicology — the measurement of relative times-to-effect, and especially time-to-incapacitation.

The significance of this emphasis on incapacitating dose, as opposed to fatal dose, is clearly demonstrated by the data in Table 1. In 1975, CAMI conducted a smoke toxicity study of 75 cabin interior materials, all of which met the Agency's current flammability standards for use in wide-bodied aircraft. Two seat-cover fabrics were burned in separate experiments and rats were exposed to the smoke. We measured both the time-to-death (td) and the time-to-incapacitation (ti). Fabric A gave a td of 8.4 minutes; fabric B, a td of 7.4. If material ranking were based on lethality of the smoke, then apparently fabric A presents less of a toxic hazard than fabric B, because survival time is longer by a full minute. Looking at incapacitation, however, smoke from fabric A incapacitated at 3 minutes, while it took 5.4 minutes to incapacitate rats with smoke from an equal quantity of fabric B. Thus, in a fire where survival is dependent on getting oneself out (and once you are incapacitated, you do not get out), material B obviously offers almost twice the time for escape as does material A. I would maintain fabric B is the safer material in terms of its potential toxic hazard in such a fire, — and thus our emphasis on time-to-incapacitation, rather than time-to-death, as the appropriate measurement.

Now, these incapacitation responses are measured using rats as the animal model, when obviously we are ultimately concerned with the relative toxicity of smoke and gases for humans. Are rats acceptable substitutes for humans — where smoke toxicity is concerned?

The answer to that question, on the part of many toxicologists, is that rats are all we have so they have to be good enough. The FAA has always felt it would like a little more assurance than that, especially if material usage might someday be regulated on the basis of toxicity test results. Consequently, we have strived to relate rat responses to predicted human responses — to the extent that existing data and/or reasonably acceptable animal testing will allow.

I, personally, have for some time felt quite comfortable about use of the rat as a model for human responses where the 'systemic' toxic gases are concerned. These are gases such as carbon monoxide (CO), hydrogen cyanide (HCN), and hydrogen sulfide (HSH) that are toxic because they react quantitatively and selectively with specific receptor systems that have a vital function in the body (Slide 2) The concentration of each of these critical receptor molecules is surprisingly constant in all mammalian species. Therefore, if a

surrogate mammal becomes incapacitated when one half of its hemoglobin is reacted with CO (or one half of its cytochrome oxidase with HCN, or one half of its sulfhydryl enzymes with HSH), the amount of the toxic gas required to accomplish that for a human would be the same amount multiplied by the ratio of their body weights. For the rat:human pair, this would be a factor of about 200, for a 70kg human as 200-times the body mass of a 350g rat.

In the case of CO, we have direct experimental data, from rats and humans, that verify this relationship. The incapacitating dose of CO for rats, as measured in our laboratory, is about 15mg/kg of body weight. This would be a dose of 5.25 mg of inhaled CO for a 350g rat. Drs. Peterson and Stewart have published data from human exposures to CO that indicate the incapacitating dose would be about 1000mg — this is about 200-times the rat dose. (Slide 3) (When the time to acquire a given dose is also involved, a 70kg person would take about 3- to 4-times longer than a rat to inhale the effective dose, since that person's minute-respiratory-volume is at least 50-times greater than a rat's:

$$(220/50 = 4).$$

Similar reasoning would apply for all other toxic gases that react quantitatively with specific receptors. Unfortunately, the human experimental data needed to demonstrate this are lacking for gases other than CO.

There is, then, a second general category of toxic gases. These gases react, not with a specific receptor target, but indiscriminately with any tissue. They are usually strong acids or bases, anhydrides, or other highly reactive molecules such as aldehydes, ketones, or unsaturated compounds. They produce widespread inflammation and generalized tissue destruction.

For several years we were quite concerned that, for this class of toxic gases, the rat might not be a useful model for predicting human responses. This was especially true after we had experimentally determined the incapacitating doses of two representative 'irritant' gases, namely hydrogen chloride (HCl) and acrolein. (Table 2) We found that to incapacitate a rat in 10 minutes required exposure to an HCl concentration of 40,000 to 50,000 parts-per-million (ppm); whereas Prof. Alarie (1973,1975,1977) has stated that about 300ppm HCl would prove incapacitating for humans in 10 minutes, and other sources suggest about 500ppm for 10 minutes. With acrolein, rats were incapacitated in 10 minutes when exposed to about 4,000ppm; whereas literature suggestions for human incapacitation range from 0.1ppm to about 30ppm.

The approximately 100-fold difference between rat and human effective doses — determined for rats and suggested for humans — prompted our serious questions concerning the suitability of the rat as a human surrogate. Either there is a problem with the rat, or, the suggested human doses are seriously in error.

This dilemma convinced us to proceed with long-delayed plans to evaluate the toxicity of such gases in a nonhuman primate species. The Southwest Research Institute (SwRI) at San Antonio was awarded a contract, sponsored by the FAA's Technical Center at Atlantic City Airport, to evaluate the effects of three gases in the juvenile baboon. The gases were CO, HCl, and acrolein; the specific incapacitation endpoint selected was loss of the ability to physically escape from the exposure cage at the end of a 5-minute exposure period.

The effect of CO and HCl on the ability of rats to perform a similarly designed escape task was evaluated also, for comparison with the CAMI endpoint for incapacitation, which is loss of the ability to walk on the inside of a motor-driven exercise wheel.

Results with rats exposed to CO in the SwRI escape test indicated (Table 3) the 5-minute incapacitating concentration to be 6780ppm; CAMI results gave 5500ppm. The CAMI rats are tested at a higher level of physical activity than the 'free roaming' SwRI rats and a difference in effective CO dose of 20% to 25% would not be unexpected, since the time needed to inhale a given quantity of a gas is inversely proportional to the minute-respiratory-volume. The 5-minute concentration that resulted in the baboon's failure to escape was 6850ppm.

For rat exposures to HCl, the 5-minute incapacitating concentrations ranged from about 80,000ppm (SwRI) to 110,000ppm (CAMI). In the SwRI tests, rats were exposed to HCl concentrations that ranged from about 12,000ppm to about 88,000ppm. The only death during exposure was at the highest concentration; that animal died just as the five-minute period ended. All rats exposed to less than 80,000ppm escaped

successfully; although all exposed to more than 15,000ppm eventually died, most of them 6 to 13 days postexposure.

(Table 4)

The baboons successfully escaped after 5-minute exposures to all hydrogen chloride concentrations tested, the maximum concentration tested being 17,290ppm. The animal exposed at 17,290ppm died, however, 76 days postexposure; the only other death occurred 18 days postexposure from the next highest concentration, 16,570ppm. (These 2 deaths may not, however, have been as a direct result of the HCl exposures.) None of the subjects seemed to even approach incapacitation during the exposures, but all that were exposed to concentrations above 12,000ppm exhibited serious postexposure respiratory problems. And, as with the rats, all exposed above 15,000ppm died postexposure.

(Table 5)

In all of the acrolein exposures, with concentrations ranging from 12 to 2780ppm, the animals were obviously distressed by the severe irritant effects. Once again, however, all animals escaped successfully at the end of the 5-min exposure. Animals from the two highest concentrations, 1025 and 2780ppm, developed severe pulmonary edema and died within the first 24 hours postexposure. The 5-minute incapacitating concentration of acrolein for rats in the CAMI test was 11,000ppm; SwRI did not expose rats to acrolein.

Summarizing the SwRI baboon results we find that although 5-minute incapacitating concentrations were never reached for either gas, the animals successfully escaped from concentrations that were 50- to 100-times higher than what has been proposed as incapacitating for humans! Therefore, our conclusion is that the suggested human limits were ultraconservative guesses. It is perhaps unfortunate that we were so influenced by these limits suggested for humans that we started the baboon exposures at an unnecessarily low concentration. Consequently we expended the animals that were budgeted for the study without reaching it for either HCl or acrolein. In a subsequent study, we plan to obtain these values, even though each such exposure will obviously mean sacrificing an animal, at least in a postexposure death.

It is clear, though, from the results we did obtain that, to the extent that the baboon is an adequate model for humans, the rat is certainly a better model for baboons and thus for humans than might have been predicted from the suggested human limits that have been utilized in the past.

## **Bibliography**

- Alarie, Yves. 1973. *CRC Crit. Rev. Toxicol.* 2:299-363
- Alarie, Yves, et al. 1975. *J. Fire Flammability (Comb. Tox. Supp.)* 2:139-50
- Barrow, C., Y. Alarie, et al. 1977. *Arch. Environ. Health* 32:68-76
- Crane, C. R., et al. 1977. FAA, Office of Aviation Medicine Report, FAA-AM-77-9
- Kaplan, H. L., et al. 1984. (SwRI Contract Report) DOT/FAA/CT-84/16

**Table 1.**  
**Comparison of Ti and Td for Two Seat Fabrics\***

<u>Material</u>	<u>Ti, minutes</u>	<u>Td, minutes</u>
Fabric A	3.0	8.4
Fabric B	5.4	7.4

\*Crane (1977)

### Body-Weight Ratio, Human:Rat

Body weight, average adult male human: 70,000 g

Body weight, average male laboratory rat: 350 g

$$\frac{70,000}{350} = 200$$

### Relative Time to Acquire Equivalent Dose by Inhalation

Incapacitating dose of CO, for both man and rat:

15 mg/kg body weight

Minute-respiratory volume = k (body weight)<sup>0.75</sup>

$$\frac{\text{MRV (man)}}{\text{MRV (rat)}} = \frac{70,000}{350}^{0.75} = (200)^{0.75} = 53$$

Relative time to acquire same dose per gram body weight:

$$\frac{200}{53} = 3.78$$

**Table 2.**  
**Ten-Minute Incapacitating Concentrations for Rat and Human**

<u>Irritant Gas</u>	<u>Concentration, ppm</u>	
	<u>Rat<sup>1</sup></u>	<u>Human<sup>2</sup></u>
HCl	40-50,000	300-500
Acrolein	4,000	0.1-30

<sup>1</sup>Rat data are from actual experiments.

<sup>2</sup>Human values are predictions (from the literature).

**Table 3.**  
**Five—Minute Incapacitating Concentrations of CO and HCl for Rats.**

<u>Laboratory</u>	<u>CO, ppm</u>	<u>HCl, ppm</u>
SWRI	6,780	80,000
CAMI	5,500	110,000

**Table 4.**  
**HCl Concentrations to Which Baboons Were Exposed  
for Five Minutes and Escaped Successfully.**

Lowest Concentration:	190 ppm
Highest Concentration for Survival:	11,400 ppm
Postexposure Fatality:	16,570 ppm 17,290 ppm

**Table 5.**  
**Acrolein Exposures for Rats and Baboons**

Baboons: Successfully escaped at all concentrations	
Lowest exposure:	12 ppm
Highest concentration survived:	505 ppm
Postexposure fatalities	1,025 ppm 2,780 ppm



**Gary Leegate**  
**V.P., DME Corporation**

Gary Leegate is Vice President of DME Corporation, a manufacturer of airline emergency radio, lighting, and survival products. He holds a Bachelors Degree in Aerospace Engineering from Georgia Tech and an M.B.A. Prior to joining DME Gary worked for three commercial airlines in a variety of capacities including Emergency Equipment Engineer. Gary is an Ex-U.S. Army Officer with service as an Air Defense Artillery Unit Commander in Korea, and as an Instructor at West Point. Gary has been a member of the SAE S-9 Cabin Safety Committee for ten years and is a past Chairman of the S-9A Sub-Committee on Emergency Equipment.

# WATER SURVIVAL A TRAGEDY IN ONE ACT

Gary Leegate

The few of you in this room who know me know that I am little more qualified to speak with authority on water survival than I am to direct a theatrical production. It follows quite logically then, that I present you this small play.

## "WATER SURVIVAL"

### A Tragedy in One Act

If you will bear with me a moment, I will set the stage and call up my cast.

*(Pause: as cast comes forward, and stage is set)*

In all fairness to this production, and the cast, this has not been rehearsed. Since the cast doesn't really know what is going to happen, or what I am going to say, it's safe to assume that they do not necessarily agree with or support the views that will be presented here. Neither do I, necessarily. We will just allow things to proceed as they will, and I have every confidence that I will, for many years, look back and ask myself why in the world I did this.

Our cast is a FLIGHT ATTENDANT, played by \_\_\_\_\_ who is a flight attendant in real life, PASSENGER NUMBER ONE, played by \_\_\_\_\_ who is often in real life a passenger, and PASSENGER NUMBER TWO, played by myself. One other cast member is needed, someone weighing between 100 and 125 pounds. This is not a lead role, and there are no speaking parts, but it is important.

*(Pause: hopefully to get my volunteer)*

This last member of the cast will play the part of a LIFE RAFT. Since we do not have an overhead bin on our set, I will ask the LIFE RAFT to take an inconspicuous and inaccessible position at the rear of our "cabin".

*(Pause: as LIFE RAFT takes position)*

## SCENE 1

**A commercial airliner about to take off  
from Logan Airport... today**

### SCENE 1:

*(The setting is the origination of a commercial airline flight today, December 12, 1984 from Boston Logan Airport. Let's say that the air temperature is 32°F and the water temperature is 38°F. The passengers have boarded and are preparing to ignore the flight*



*attendant who is preparing to deliver her emergency briefing)*

**FLIGHT ATTENDANT:** "Good morning, and welcome to Bad Luck Airlines flight number zero. Please take a few minutes to review some safety information with me..... (the remainder of the briefing, including a life vest demonstration).

*(Aside).* Since I am producer and director, I can exercise a certain theatrical license by stopping action at any point in the progress of the play, and performing another role as commentator. This is one of those times.

**It is estimated that nearly 70% of commercial airline arrivals or departures occur over significant bodies of water each year.**

It has been estimated that the setting of our little drama is acted out in real life approximately 7 million time a year in the United States, as scheduled airline flights take off or land over "significant" bodies of water. That may represent almost 70% of all airline arrival/departures.

**FAA Staff Study Slide on  
Accident Profile by Flight Regime**

The Federal Aviation's recent "WATER SURVIVAL STAFF STUDY" presents data that indicates for the twenty year period from 1959 to 1979, 27.6% of all jet accidents occurred in the takeoff, or climbout flight regimes, and 54.5% occurred in final regime from initial approach to landing.

The FAA's study points out that the probability of a ditching or water landing is extremely low due in part to jet aircraft reliability, and that such accidents, if and when they occur are usually characterized as non-survivable. Still, with seven million takeoffs or landings over water each year, it is fairly easy to acknowledge the possibility that we will have water accidents, and our limited experience includes some that were survivable.

**SCENE 2**

**The same aircraft cabin two or three minutes after takeoff.**

## SCENE 2:

*(The setting is the same aircraft cabin two or three minutes after takeoff, immediately after the senior flight attendant has been notified by the captain that the aircraft is in trouble and that a ditching is imminent)*

**FLIGHT ATTENDANT:** ...*(provides emergency announcement which may include seat belt, life vest, seat bottom cushion, emergency exit, and life raft instructions — hurry, you only have a few seconds.)*

*(Aside).* Some of the passengers, and the flight attendant, search for and with varying degrees of success locate and don their life vests, while Stan Switlik wonders which of the ten or more different varieties (or mix of those) he will find. He doesn't even care if they are Air Cruisers'. Mothers with infants in arms wish their children were harnessed in child restraints. Jerry Schneider wishes that he were sitting in a 20g automobile seat instead of a 9G airline seat. Wayne Williams pulls his own personal life preserver out of his briefcase thinking that this is a ironic way to end his career. A close friend of mine a couple of seats over, Randy Stigleman, who boarded the airplane in a wheelchair wishes he was anywhere else but here. Some of the rest of us are wishing that the Flight Safety Foundation had had this conference twenty years ago.

## SCENE 3

**The aircraft cabin immediately after the crash.**

## SCENE 3:

*(The setting is the same, immediately after the aircraft has settled in the water. Fortune has smiled on our cast; notwithstanding the high probability that the aircraft will break up and most of us will be incapacitated to killed outright in the crash, the aircraft has remained intact, and there has been little failure of cabin furnishings. Though bruised and buffeted, our cast has survived the crash, and with the exception of my friend Randy and the life raft, are ambulatory. The flight attendant is leading the evacuation.)*

**FLIGHT ATTENDANT:** ...*(exhorts passengers to exit the aircraft)*

*(Auditorium Lights Off)*

*(Aside).* Before I leave the aircraft to jump in the water, a bunch of questions are flashing through my mind: How many of us found our life preservers and how many of us got them on? Did anyone grab a seat bottom cushion on the way out? How long will they be able to hold on in this cold water? The evacuation slide inflated, but does it have a quick disconnect feature so we can use it to hang on to? What about the life raft? Does anyone have time to go and get it before this thing sinks? Do I have enough courage to try to help or am I going to take care of myself? — I don't know the answers. Let's get into the water and see what happens.

## SCENE 4

**The cold waters of the Atlantic ten miles from Logan airport**

#### SCENE 4:

*(The setting is now the cold waters of the Atlantic off Boston, about ten miles from shore. The water temperature, again, is 38°F and we have moderate sea conditions. It is dark. "Survivors" have exited from the "cabin" and have jumped off the raised platform.)*

*(Aside). While the cast is waiting for providence to intervene, let's take a look at their situation as the Coast Guard SAR office in Boston sees it. This information was provided by the National Transportation Safety Association who had requested the Coast Guard provide an analysis of accident response at three large coastal airports.*

**NTSA Slide on Boston Rescue  
Capability vs Environment**

Boston based Coast Guard SAR has at its access a number of rescue craft which are indicated here versus their response time to the accident scene and the number of survivors they could safely rescue. You will note that the first rescue craft is dispatched approximately 30 minutes after aircraft touchdown, and arrives at the scene about 10 minutes later.

By this time a lot has happened. The Coast Guard medical experts indicate that in our accident, most non-swimmers, disabled persons, and small children have become fatalities in the water within five (5) minutes. Most of us will lose the use of our hands and forearms in 10 to 15 minutes. **AT THAT POINT WE WILL NO LONGER BE ABLE TO HOLD ONTO SEAT BOTTOM CUSHIONS, OR OUR CHILDREN FOR THAT MATTER.** We lose functional mental facilities within 45 minutes, and we will all be dead due to hypothermia effects in 70 minutes. A lot of us will be dead from hypothermia related drowning well before then.

It looks like that perhaps twenty four (24) of us could be pulled from the water before the loss of mental facilities, though by that time all of us that were totally immersed in the water have been without use of our hands and arms for some time. Eighty three (83) of us could be pulled out before death from hypothermia, but many of those would still be fatalities if body core temperature therapy could not be administered almost immediately.

**BLANK/DARK**

This is all hypothetical and speculative. There are many experts in the audience who could take exception with any of these statistics and argue for a happier or a still more catastrophic situation.

Aside from the fact that this was billed as a tragedy, let's have a happy ending. It so happens that our crash occurred almost in the middle of regatta, and with much the same luck the survivors of the Escambia Bay accident enjoyed, we are rescued after only losing the few of us who couldn't don our life preservers in total darkness while dog paddling in 38°F water.

**CURTAIN**

**BLANK/DARK**

I would like to thank my cast for the courage to come up here and be guinea pigs in front of such a large audience.

*(Pause: As cast returns to seats)*

Now, let's get back to the real world. The FAA's recent staff study has quite a bit to say on the subject of water survival, and it will certainly be the major agenda item in the coming working sessions on this subject. Let's take a look at what the staff study says: (These are direct quotes from the

**"...the agency's (FAA) primary actions are rightfully directed at prevention of such accidents. If accident probabilities can be reduced to very low levels, then post accident protective measures can reasonably be appropriately adjusted."**

**"In the case of water accident safety in commercial aviation, it appears that the existing post accident safety boundaries are generally commensurate with these risks."**

**\* \* \***

**"...the magnitude of the problem is insufficient to justify any increase in required water survival equipment aboard aircraft."**

The FAA staff study talks about equipment and training, as well.

**"Recent near incidents or accidents have highlighted the role of human error and emphasized the need for improved training and increased or redirected surveillance, as ameliorative measures, rather than the need for more or different flotation equipment."**

**\*\*\***

**"...it appears that existing on-board rafts are of questionable value under any condition, but particularly in the inadvertant case..."**

**"As it stands, vests provide no added measure of protection from hypothermia or the effects of hypothermia over flotation cushions."**

**\*\*\***

**"Equipment access and operation is paramount, and in the inadvertant water accident case, cushion access might initially be the best of all the possible devices since they require no special operation or donning procedures."**

**"It might be expected that those proponents of quick-donning vest designs would themselves have provided such a design by now. That they have not done so and that no single universally acclaimed vest.... has appeared, documents the fact that apparent superiority of one device over another is often a matter of opinion."**

An agency vest standard would have to essentially specify one of the existing models as the chosen one. It is unlikely that this would benefit anyone other than the manufacturer of the chosen device.

The recommendations of the staff study center on the following subject areas:

**FAA STAFF STUDY  
RECOMMENDATION**

- 1) **Seat Fire Blocking**
- 2) **Flotation Platforms**
- 3) **Airport Response**
- 4) **Crew Training**
- 5) **Vest Donning Compliance**
- 6) **Flotation Cushions**
- 7) **Pilot Training**
- 8) **Life Vest Access**
- 9) **Escape Slide Disconnects**

- 1) Augment regulations requiring seat fire blocking to include flotation capability.
- 2) Encourage industry to continue development of flotation platform standards. Consider requests to substitute such devices for rafts when their technology is sufficiently developed.
- 3) Develop advisory guidance to airport operators in the areas of rapid response procedures and specialized rescue equipment.
- 4) Require operators to include crew training for inadvertant ditchings.
- 5) Develop criteria for assuring 15 second vest donning compliance.
- 6) Continue research on modified flotation cushions and other individual flotation devices. (The FAA's CAMI facility is quite active in this area with, among others a newly designed zip-front vest that is reportedly easier to don while providing added insulation protection against hypothermia effects.)
- 7) Emphasize water accident hazards to pilots during training and check-rides.
- 8) Examine current life vest storage media to determine if vest access problems exist; take action as necessary.
- 9) Examine feasibility to phased change to quick disconnect feature on narrow-body aircraft evacuation slides, so that they may be used for flotation.

Quoting out of context is tricking business, and usually unfair. I certainly don't mean to represent that I have either effectively or completely stated the FAA's position on the water survival issue.

I offered the preceding slides to elevate some positions taken by the FAA that are not universally accepted, positions that I trust will be debated with some heat in the following working sessions.

Since I am a self-proclaimed non-expert on the subject, I will act as the spokesman for the hypothetical survivors of our little drama today, and give you what I think their conclusions might be.

### CONCLUSIONS OF THE SURVIVORS

- 1) Accident Probability
- 2) Accident Survivability
- 3) Regulations versus the problem
- 4) Airport area rescue response
- 5) Life Rafts
- 6) Flotation Cushions
- 7) Life Vests

- 1) We have had water accidents and we will continue to have them. Notwithstanding the low statistical probability of a survivable airline water accident, we suffer the risk of putting an airplane full of people in the water hundreds of thousands of times a year.
- 2) Our limited experience with survivable water accidents establishes without a doubt that we will suffer post crash fatalities due to drowning and hypothermia.
- 3) Our maximum exposure to water accidents is in the immediate area of the air terminal; current regulations do not require any water safety equipment, save flotation cushions, unless the aircraft operates more than 50 miles from shore.
- 4) Airport area rescue facilities, even supported by other agencies such as the U.S. Coast Guard, are not now able to adequately respond to aircraft water accidents in time to save even able bodied survivors in cold water environments.
- 5) The multiple 125 pound life rafts that we carry stocked with survival rations, medical supplies, and canopies will not be deployed in the real, likely accident scenario.
- 6) Seat flotation cushions can be deadly placebos in cold water conditions — you may exit the aircraft with it thinking it will save you, only to slip away and drown in as little as ten minutes because you can no longer hold on to it.
- 7) Life vests are not effective in the most likely accident scenario for a variety of reasons including inaccessibility, non-standard configurations, lack of passenger education/awareness, insuitability for the entire range of potential wearers, and designs that encourage the aspiration of water.

I have read that you should never make a presentation unless it ends with a call for action. If action wasn't necessary, I assume the Flight Safety Foundation would have found another topic to fill this time slot. So let's talk about action for a minute.

I doubt that very many people who are important to interests of aviation safety, and particularly water accident survival are absent from this meeting, thanks to the Flight Safety Foundation. It is this group, the individuals, companies, and agencies that must take responsibility for the safety of airline passengers in this and following generations.

We can talk about cost-effectiveness, and reasonable risk in the context of safety, but let's don't talk out of both sides of our collective mouths. On board fires are also very rare, but because of a couple of recent

accidents that raised our awareness of the problem, we have stacks of new regulations and lots of dollars committed to those changes.

After doing some missionary work on the flotation platform concept, which is just a piece of the puzzle, I have reached the personal conclusion that we can address the real water accident safety hazard, and at a much lower cost to the operators, in the long run, than they will pay to continue with our current regulations. I hope we have a chance to discuss that in the working sessions.

Just a few days ago, I was discussing with a representative of one of our regulating agencies an unrelated, but significant safety problem involving the carriage of non-TSO'd large capacity lithium batteries in aircraft cabins. He said with a great deal of despair (a direct quote) that "we can't do anything until there is blood on the ground".

Let's don't wait until we have any more "blood on the ground" or bodies in the water. Let's don't wait until we have the water accident equivalent of an Air Canada cabin fire to appropriately address the problem. Let's don't wait until our statistical analyses catch up to us, and we have one of those rare water accidents that proves that the hazards we talk about are real.

The FAA should not be our scapegoat — a place to pile the blame when accidents happen because they didn't *make us* change. If we could agree today on what is needed to address the real water accident risks, and our FAA friends could write the laws effective tomorrow, it would still be ten years before their full benefit could be felt.

I believe that we in this room have a great opportunity to put a mark on the progress and future of aviation safety. And I believe that we have an obligation to sneak out of our corporate, political, or regulatory skins and do it.



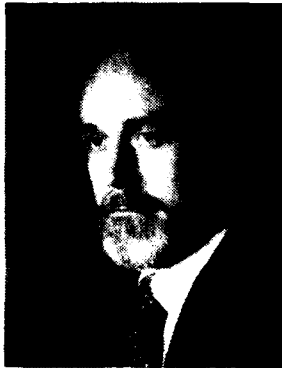

**Dan Johnson**  
**President, Interaction Research Corporation**

Dr. Dan Johnson worked in the passenger safety program at Douglas Aircraft for 10 years. He helped in the design and evaluation of safety equipment for DC-9 and DC-10 aircraft and also conducted experiments on passenger reactions during emergencies. From these studies he determined that improved passenger safety could be obtained by increasing passengers' awareness of safety equipment and procedures. He formed a company, Interaction Research Corporation, Olympia, Washington, which is involved in cabin crew training, passenger briefing cards and video tapes for commercial and corporate operators. He has also conducted crisis intervention sessions for crewmembers following several recent aircraft disasters. While at Douglas he attended Claremont Graduate School where he earned an M.A. and Ph.D. in Psychology. He is a part-time Instructor in Human Factors for the Institute of Safety and Systems Management at the University of Southern California. He has written many technical reports and the book, "Just In Case: A Passenger's Guide To Airline Safety and Survival" which was published in March, 1984.

# PASSENGER SELF-HELP PROGRAMS

Dan Johnson

Most would agree that aircraft passengers who know what to do in an emergency are more likely to react quickly and correctly when an emergency arises than those who do not know what to do. Furthermore, one commonly reads in accident reports of passengers who couldn't put on their life preserver, use an oxygen mask correctly, or find and operate the nearest emergency exit. While passengers today may figure out some safety information for themselves, they will have to learn other information from sources aboard the plane, namely the flight attendant briefing, video briefing tape, safety briefing card and emergency information placard. This paper examines some of the advantages and disadvantages of each of these sources and gives recommendations for improving passenger briefings.

## FLIGHT ATTENDANT BRIEFING

### Advantages

1. One advantage of the flight attendant briefing is that the passenger has to expend little or no effort to receive the information. Before normal flights, safety information seems of little relevance to most experienced passengers, and if it requires an effort on their part to get such information, then most will simply choose to go without. Attending to the flight attendant briefing is certainly easier than taking notice of the various placarded equipment locations on the plane while boarding, or sifting through the seat back material in order to find the safety briefing card. It comes as no surprise that most passengers gain most of their knowledge of safety procedures primarily from the flight attendant briefing.
2. A potential (though little used) advantage of the flight attendant briefing is that it can be altered to increase its novelty, and thereby the attention paid to it by passengers. Occasionally, one notices a flight attendant who gives the briefing in such an unusual and interesting manner that nearly everyone pays attention.
3. Another advantage (also seldom used) is that crewmembers can interact with the passengers, answering questions, and encouraging the passengers to attend.
4. A major advantage of the flight attendant briefing is that, when an actual emergency has occurred, the flight attendant can give specific information to the passengers, or modify, if necessary, previous commands. This flexibility to modify the information received by passengers in response to a specific situation is a prime benefit of flight attendant briefings.

### Disadvantages

1. A major disadvantage of the flight attendant briefing is the limited information that can be communicated. While exit locations are indicated in the briefing, how to open them and leave the plane is not. Raft locations may also be pointed out, but how to retrieve and use the rafts is not. Even the most basic information, how to assume the brace position, is not covered because it doesn't easily lend itself to verbal description.
2. Another disadvantage is that the information is delivered at a given pace and the passengers must keep up to understand. (Some other forms of communication are not limited in this respect, as will be seen later.) This requires passengers to perceive, comprehend, and store the safety information in memory at a pace dictated by the person giving the briefing.
3. A further disadvantage is that a flight attendant briefing, being primarily verbal, will not be understood by someone who doesn't speak the language.
4. A final disadvantage of many briefings is that many people don't pay attention to them. In part, this could be because they are given in a standard format within many airlines, and even different airlines have similar formats. Undoubtedly such standardization ensures that all required safety information

is provided each time. Unfortunately, it seems to result in passengers believing that briefings are the same, and since little new information seems forthcoming, many pay no attention.

## VIDEO TAPE BRIEFINGS

### Advantages

1. A major advantage of a video tape (or motion picture) safety briefing is that it can present more information than the flight attendant briefing. For example, door opening and slide inflation, brace positions, and putting the life vest on children are some of the areas that the flight attendant does not cover, but which can be shown on a video tape.
2. A second advantage is that a video tape can demonstrate the use of equipment, such as life preservers and oxygen masks, even better than the flight attendant can. One laboratory study (Johnson, 1973) found that viewing a well-designed video tape can increase the ability of people to put on life vests compared to those who saw a flight attendant demonstration.
3. A further advantage is that a video taped briefing, being mostly pictorial, can communicate to even those who don't understand the accompanying narration.
4. Another possible advantage is that some passengers will be able to see the video screen better than the flight attendant demonstration, depending on seat back height, passenger height, location of the screen, distance from the flight attendant, etc.
5. Passengers need not expend effort (other than looking and listening) to gain information from the video tape.

### Disadvantages

1. As with flight attendant briefings, video tapes share the disadvantage of being presented at a predetermined pace, requiring passengers to keep up with the flow of information regardless of their ability to do so.
2. A second disadvantage is that the information cannot be reviewed when quick action is required. In some emergencies there might be adequate time to review a video tape between the warning phase and the time passengers would need to perform crucial actions (e.g., warning prior to emergency landing or a ditching). But in most emergencies there would be no time to put the video tape on the machine and to bring up on screen the specific information relevant to the emergency.

## PASSENGER SAFETY INFORMATION CARDS

### Advantages

1. A safety card has the advantage of being a form of self-paced instruction. Because the passenger can study each section of the card until it is understood, more complex information can be presented than by the flight attendant briefing, and (perhaps) even by the video tape.
2. Safety information cards can be easily referred to anytime during the flight and thus have an advantage over other sources of information. It has been reported that when in-flight emergencies have occurred, and time was available, passengers closely studied the safety cards.
3. The safety card can depict information that cannot be provided by the flight attendant briefing. It can show raft locations at a glance, depict several types of brace positions, and illustrate exit operation.

### Disadvantages

1. To learn the safety information passengers must search for and read the card. Most will not expend the

effort to do this on a regular basis unless they have reason to, such as special encouragement from a crewmember or the occurrence of an inflight emergency.

2. A disadvantage of a safety card which attempts to provide information with a large number of words, or poorly designed pictures, is that it requires the reader to expend more effort to understand than a well-designed card.

## EQUIPMENT PLACARDING

### Advantages

1. Location Placards (those which indicate the location of a piece of equipment, such as a life vest or an exit) and Informational Placards (those which give instructions on how to use the equipment) are permanently attached to the equipment, or are attached to a specific location someplace in the plane. If correctly located they will be visible to the passenger or crewmember when needed. The advantage of this is that the person need not rely on memory (which is sometimes unreliable under the stress of an emergency) to find and use the equipment.
2. Instructional placards have the advantage of displaying information that is impractical to provide by the other information sources.

### Disadvantages

1. The major disadvantage of placards occurs if they are designed, or located, in such a way as to be ineffective when needed. To be effective, placards rely on a person's ability to see and understand the displayed information during the time it is needed; that is, during an emergency. Placards can be ineffective for a number of reasons:
  - a. Environmental — Under poor visual conditions placards may not be seen or easily read.
  - b. Past experience — Passengers may not understand the words or symbols used on placards.
  - c. Placement — An exit sign near the ceiling may be obscured by smoke; donning instructions on the back of a life jacket may go unseen by the user.
  - d. Complicated instructions written on a placard may not be comprehended by a person who, under stress of an emergency, tries to quickly perform a task.

## CONCLUSIONS AND RECOMMENDATIONS

Prior to a normal flight, passengers should be given adequate safety information in a form which requires the least amount of effort on their part. This can be accomplished by using a well-designed video tape, or when that is not possible, an attention attracting flight attendant briefing.

Both the video and flight attendant briefing must be designed in such a way as to catch, and hold, the passenger's attention, otherwise there is no legitimate reason for having them. A video tape is not going to gain passengers' attention simply because it is a video; it must be designed to gain and hold passengers' attention each time it is shown.

Each source of information has advantages, and disadvantages, not shared by the others. (See Table 1.) As such, the most effective method of providing passenger safety information would be to make the best use of each source. Unfortunately, the only obstacle is that many aircraft are not equipped to show video tapes or motion picture briefings.

**TABLE 1**

Passenger Safety Information Requirements	Information Source best suited for satisfying requirement			
	F/A	Video Tape	Card	Placard
1. Relatively complete overview of most safety equipment and procedures		X	X	
2. Relatively detailed information on each particular procedure			X	X
3. Individual help during emergency	X			
4. Little effort expended to receive information	X	X		
5. Self-paced information transfer			X	X
6. Understood by passengers regardless of language		X	X	
7. Information can be provided to passengers prior to emergency occurring	*X	X	X	
8. Information can be provided to passengers after emergency occurs (Review for quick action)	*X		X	X

*\*The Flight Attendant Briefing may or may not be effective in meeting requirements 7 and 8, depending on the emergency situation.*

### **Video Tapes**

For those aircraft equipped with video tape capability, interest arousing instructive video taped safety briefings can be shown, but this will require imaginative techniques. Simply showing a flight attendant talking, or actors going through a staged demonstration of what is usually shown in the flight attendant briefing, or close-up pictures of the briefing card, will not use the full potential that video has to instruct the passengers in an interesting and informative manner. A number of methods can be used to generate passenger interest, including content (slide inflation, exit operation), sound effects, background music to generate excitement, interesting characters, illustrations and computer-generated graphics, and situational drama.

There is only a short time, of perhaps three to four minutes in which to convey to passengers an overview of the safety equipment and procedures. This overview should also emphasize the need for passengers to study the passenger safety information card, identifying it as a source for more detailed instructions.

Airlines should not try to emulate each other, for this will result in a "standard video tape briefing". A passenger, having seen one of a similar format, will be unlikely to attend the next one. But if each airline has a different presentation for each of their models of aircraft, interest can be maintained. Differences among airlines, and peculiar to aircraft, or piece of emergency equipment, should be highlighted, and emphasized, in the presentation.

### **Flight Attendant Briefings**

For those airlines without video tape capability, a flight attendant briefing should be given prior to takeoff, but the briefing should be quite different from most of those currently given. Airline management should encourage the flight attendants to be innovative in presenting the information. And the flight

attendants should be convinced that each briefing is of vital importance to everyone on board.

Passengers must be convinced that the flight attendant (or video tape) briefing and the safety cards, are both of considerable importance. There is evidence that if passengers thought attending to these sources was as important as buckling their safety belt on landings and takeoffs, then more would attend (Johnson, 1980). By emphasizing the comparable importance of these actions, more passengers could be induced to attend both the briefing and the safety card.

## Safety Briefing Cards

The briefing card should provide relatively detailed information on all the safety procedures and equipment passengers may need to know. It should be easily understood regardless of the language passengers can read. This requirement usually means that pictures rather than words be used on the card.

One unfortunate aspect of pictures is that what is clearly communicated to one person may appear ambiguous to another. Just one of many such ambiguities is shown in Figure 1. The intended message is to remove high-heeled shoes, but some people interpret it to mean, "no loose shoes", or, in other words, to keep shoes on.



FIGURE 1

Figure 1. A commonly misinterpreted picture. Many believe it means that empty shoes are forbidden, and so should be kept on.

Each airline should undertake the testing of their safety briefing cards to determine whether the information is being communicated in an unambiguous manner. Recommendations on what information should be shown on cards are provided by the SAE (Reference, Aerospace Recommended Practice ARP 1384, Society of Automotive Engineers, 400 Commonwealth Dr., Warrendale, PA 15096, U.S.A.).

## Placards

Passengers gain information from placards under normal as well as emergency conditions, but only under emergency conditions may critical problems of a placard be realized. Periodic analysis and evaluation of locational and instructional placards should be carried out to determine if:

- a. The placards can be seen under emergency conditions.
- b. They are understood by passengers.
- c. The described procedures on the placard can be performed.

A placard which fails any of these criteria should be replaced.

More information on emergency placarding is provided by the SAE (ARP 577 and ARP 503). Although in neither one of these documents is it recommended that the passenger's understanding be evaluated, other industries do recommend testing the understandability of instructional graphics. (ANZI, 1972; ANZI, 1973; CAN FIP; DoT, 1974; ISO, 1980; ISO, 1975; NFPA, 1980.)

## SUMMARY

Any method of instruction must first attract and hold the passenger's attention. Video and flight attendant briefings can, and should be, developed with this in mind, especially avoiding "standardized" presentations.

Under threat of an emergency, however, passengers will actively seek out instructions. Safety information cards and placards can be readily available. However, the design of these instructions must consider the stresses that passengers may be under. Generally, pictorial instructions are preferred to written instructions, and should be tested for effectiveness.

## REFERENCES

ANZI Z35-1972 *Specifications for Accident Prevention Signs.*

ANZI Z35.4-1973, *Specifications for Informational Signs Complimentary to ANZI Z35.1-1972.*

CAN FIP, Federal Identity Program, *Graphic Symbols for Public Access Areas and Occupational Environments.* Treasury Board of Canada

DoT-OS-40192, *Symbol Signs*, 1974

ISO DIN 32830 (Proposed Revision of ISO 3461) *Graphic Symbols*, 1980.

ISO 3461-1976, *Graphic Symbols — General Principles for Presentation.*

Johnson, Daniel A. "Effectiveness of Video Instructions on Life Jacket Donning," *Proceedings of the Human Factors Society Annual Conventions*, Human Factors Society, Santa Monica, California, October, 1973.

Johnson, Daniel A. "Emergency Safety Instructions: Who Attends and Why?" *Human Factors in Transportation Research*, Vols 1 & 2, Osborne & Levis, Eds) Academic Press, London, 1980.

NFPA 178-1980, *Standard Symbols for Fire Fighting Operations.*

**SESSION VI**  
**ECONOMICS AND REGULATORY CONSIDERATIONS**

NOTE: The following papers were presented without a panel moderator.





**Thomas D. Hopkins**  
**Associate Professor**  
**University of Maryland**

Doctor Hopkins earned his Ph.D. in Economics at Yale University in 1971.

In addition to teaching and consulting in the private sector, he has served as Acting Director of the Council on Wage and Price Stability and as Deputy Administrator of the Office of Information and Regulatory Affairs for the Office of Management and Budget.

He is currently a Visiting Associate Professor at the University of Maryland School of Public Policy.

# ECONOMICS OF SAFETY

Thomas D. Hopkins

We face an imposing array of safety hazards in nearly every aspect of our daily life. As a matter of public policy, some of these hazards are singled out for collective action while others are left largely to the basic prudence of individual behavior. The former — those for which some intervention by government is sought — include a diverse collection drawn from the universe of all safety risks. One dimension of this diversity is the level of risk itself; we as a society have selected for public action many quite low as well as many quite high risk areas.

Just within the transportation sector itself, governmental safety efforts span modes whose accidental death risks range widely. In 1980, passenger fatalities per 100 million passenger-miles were as high as 1.32 for autos and taxis and as low as 0.01 for domestic scheduled airplanes. [1] Aircraft cabin safety initiatives clearly fall within the low-risk segment of this range. While there is understandably great concern about the ever-present possibility of hundreds of deaths from a single tragic event, in fact FAA analysis in September 1984 suggested that no U.S. certificated air carrier had had a fatal fire incident — the focus of most recent regulatory activity — for over five years. [2]

This may be a reflection of prudence or good luck, or both. It certainly invites questions about the logic of choosing for government attention areas such as aircraft cabin safety with already enviable safety records. The very essence of economics is the allocation of scarce resources to improve our material well-being. Since devoting resources to greater safety efforts in one area necessarily restricts society's ability to take on other efforts, decisions involve tradeoffs, either explicitly or implicitly. Decisions, in other words, imply targeting and the relative neglect of some problem areas.

Two considerations warrant particular attention in thinking through these choices and tradeoffs. The first is the adequacy of individual discretion, and the second is the cost as well as benefit of making discrete changes. When an individual has ample information about a safety hazard and discretion to lessen or avert it through reasonable efforts on his or her part, the merit of government intervention can be questioned, whether the particular risk is large or small. A mountain climber or deep sea diver in this regard may warrant less continuing government attention than a 747 passenger, despite the fact that the latter is more apt to survive the experience. The airline passenger, in the absence of any government intervention, would probably find it more difficult to obtain and appraise safety information, as well as surely more difficult to take prudent action to lessen the hazard, than the other two individuals. While in one sense boarding a plane is a voluntary action, it is reasonable to question the practicality of not boarding as a risk reducing effort. Moreover, by long tradition, consumers have come to expect that there is little need for individual judgment here, in that adequate safety of public transportation is ensured through other means. Certainly the arrival of airline rate and entry deregulation has not lessened the government's historic safety role, and without question thorough enforcement of existing safety regulation is essential.

The second consideration shifts attention away from where responsibility should reside and toward the potential changes that could be made. Suppose the most promising initiative in a certain area produces negligible risk reduction relative to its cost. Even if the total level of risk in that area is high, one logically could want to shift priorities toward other areas where bigger safety payoffs are attainable. Thus cabin safety could well warrant further regulatory attention despite its admirable safety record if relatively low cost measures can be found for nontrivial further risk reduction. This, at least, is the course to follow if society wants the greatest overall reduction in death and injury for any given level of safety efforts expended.

Efforts to lessen the risk of death and injury can be appraised, of course, from a number of differing perspectives. From the vantage point of an economist, a key focus is on the mix of policy actions selected and the stringency with which they are applied.

## Mix of Policy Instruments

To the extent that an area such as cabin safety is targeted for public policy attention, a broad array of government responses deserves review. Regulation has come to represent the dominant policy response, and it often is a perfectly sensible policy instrument. But it is not the only one. The chief alternative comes

under the general heading of information strategies. Government efforts to generate better information about safety problems and how they could be resolved is a central example. There is reason to believe that the incentive in the private sector for research into passenger safety may be inadequate. Expenditures by any one carrier or manufacturer may lead to better information about innovations for which there is little market demand and/or little likelihood that an initiator could garner enough of the benefits to warrant the investment. Information about better safety equipment or practices is hard to ration by price.

Equally important is the dissemination of safety information itself — making sure that the public as well as all producers are fully informed of benefits from improved practices. A good idea, widely disseminated, can in and of itself lead to substantial improvements whether or not embodied in regulation. Indeed, often the rulemaking process is so laborious and protracted that improved safety measures are in place long before officially mandated. It would seem useful, thus, to try to learn what motivates some portion of the industry to move faster than others in voluntarily implementing safer practices (whether or not they may be heading for rulemaking).

### **Stringency of Measures Taken**

More stringent application of any particular policy instrument such as a new regulation translates rather directly into greater costs incurred for compliance. These costs include those incurred by the government as well as by private parties. The time pattern of these costs is quite pertinent, since a cost deferred is in general a cost reduced. Thus stringency is a matter of what is to be done and how soon. Similarly, whatever safety benefits are anticipated will in general be lessened by delay and increased by more extensive and more demanding change.

In a sense the threshold question is whether a particular type of regulation should be applied at all. If so, the remaining key question is how stringently to proceed. Rarely is the situation devoid of flexibility; ordinarily numerous ways exist to tier the decision-making to permit consideration of successively more demanding actions. This has the important advantage of allowing incremental analysis of both compliance costs and safety benefits. The question of retrofit, for example, warrants such incremental analysis; a requirement that on benefit-cost grounds makes good sense for new aircraft may or may not for older aircraft with more limited life.

Typically, once stringency levels reach a certain point, additional benefits begin to rise more slowly and additional costs more rapidly. As a simple matter of arithmetic, this means that an initiative, viewed in its entirety, may continue to look sensible even when it extends beyond its optimal level of stringency. For each incremental tightening up after the optimal point is reached adds more cost than benefit, thus lessening the potential total net benefits from the initiative. Indeed, if the overall conclusion about a package is that its total ratio of benefits to costs just exceeds unity, a yellow warning light should go on. One would want to ask whether backing off in stringency might enable us to shed certain poorly justified features and actually enhance the value of the whole. Ratios of total benefits to total costs, as well as summary statements showing that total net benefits are non-negative, are apt to hide important decision-making information.

### **Economic Analysis Requirements**

Each of the most recent three Presidents has issued administrative requirements concerning the economics of regulation. With steadily increasing thoroughness and explicitness, these requirements have come to embrace traditional tenets of formal benefit-cost analysis. Certainly the most ambitious of these requirements is that now in place in the form of Executive Order 12291, but its predecessors going back to Executive Order 11821 of 1974 had considerable similarity. Corresponding to the directive embodied in the Executive Order is guidance issued in the first instance by the Office of Management and Budget and then more particularly by the individual departments affected. The Department of Transportation and its component Federal Aviation Administration have their own relatively longstanding and quite solid guidance documents for their policy officials, which provide useful specificity in translating the broad intent of the EO into actual practice. [3]

The economic inquiry called for by Executive Order 12291 in essence has two quite different but complementary thrusts. No regulation is to go forward toward implementation until the proposing agency clearly has shown that:

- a) no alternative remedy or mechanism can adequately solve the problem, and
- b) the contemplated regulation would produce greater net benefits to society than would any alternative.

For "major" regulations, such as those having compliance costs above \$100 million annually, this showing must be provided in a Regulatory Impact Analysis (RIA) issued at the time of publication of a proposed rule (and again, suitably revised, when a final rule is promulgated). An RIA has five elements:

- 1) explanation of the need for a regulatory remedy;
- 2) consideration of alternative regulatory approaches;
- 3) analysis of the benefits and costs of key alternatives, quantified to the extent practicable;
- 4) rationale for choosing the particular proposal; and
- 5) statement that the action is legally defensible.

Each department of course can establish additional requirements. Indeed the Department of Transportation requires an economic analysis for every regulation; for non-major regulations, this takes the form of a slightly less comprehensive Regulatory Evaluation.

At six month intervals each department announces its current and anticipated regulatory proceedings, indicating which are major. In the October 1984 version of this semiannual agenda, the FAA reported that no major rulemaking is on-going or projected; even the controversial anti-misting kerosene initiative was, surprisingly, termed non-major. [4] In any event, a total of 22 actions were described as current and projected non-major but priority rulemakings, all but five of which are basically aimed at safety (as distinct from noise and delays). Thus what we have is a fairly large number of rather small but quite discrete regulatory initiatives.

To the extent that each rests on solid analytical underpinnings — and the prospects for this are greater at FAA than at many other agencies which limit their analytical focus to major rules — final decisions are likely to be reasonable. But the main drawback to such piece-meal activity is that how well all the separate pieces fit together as a sound safety strategy may not be easy to determine. Moreover, how adequately costs and especially benefits are attributed to particular rules becomes open to question. It is particularly important to guard against inadvertently letting the benefits estimates for particular rules add up to a total, once all rules are viewed as a set, in excess of likely risk levels. A broad, cumulative appraisal of these and other past discrete safety actions would be helpful in providing perspective on the merits of further changes, at best, or at least reassuring if the result simply shows that "all's well."

In the absence of satisfactory cumulative information on either the costs or benefits of FAA safety regulation, the balance of this paper discusses a few key analytical issues that arise in safety regulations.

### **Base Case Issues**

Numerous forces bear on the level of risk of safety incidents. Any effort to identify the contribution that a new regulation can make in further lessening the hazard should be directed at the dual question of what would be the future level of hazard without the regulation and what other corrective influences are likely to be present.

FAA's Regulatory Evaluation of the Floor Proximity Emergency Lighting final rule is instructive in this regard. The hazard at issue is the restricted visibility due to smoke from a cabin fire, slowing exit once the aircraft is on the ground. The remedy is additional lighting nearer the floor where the smoke is less dense, to help passengers find exits.

In estimating the likely number of cabin fires in which this measure would be helpful, FAA assumed that the fire fatality experience of US airlines over the period 1965-83 is the best starting point for benefit

calculations. Yet were the base period assumed to be the past ten years, the number of deaths potentially avoidable by this regulation falls from 44.5 per billion passenger enplanements to 36.6 per billion. [5] Indeed if the past five years are considered more representative of what lies ahead, there were no pertinent fatalities and so no plausible benefits.

FAA did factor into its estimates other likely prospective safety efforts, but this does not allow for the possibility that fire hazard reduction efforts outside of the regulatory sphere over the past two decades may have lessened the problem already. And if true, the benefits of this rule are dubious. The problem is not of great significance in this particular proceeding, since the costs are quite small. But the issue could readily arise with greater importance in other cases where the costs are more substantial. The point is that care should be taken to use realistic estimates of the magnitude of the risk actually being encountered, and sensitivity analysis showing how results vary with differing risk reduction assumptions.

### **Treatment of Alternatives**

As previously discussed, alternative remedies for a safety problem cover a wide spectrum and differ in their relative costs and benefits. Confidence in the wisdom of a particular regulatory action can be enhanced by some analytical attention to principal alternatives, including those that build on the self-interest of the carriers themselves. That is, since property loss, safety reputation and liability exposure are central concerns of the industry, some showing of their inadequacy and of how an added remedy can buttress them is needed. In this regard, research and publicity about safety initiatives and relative hazards across individual operators may warrant particular attention.

While this may appear rather obvious, some related analytical issues remain troublesome. FAA's Regulatory Evaluation of the proposed Airplane Cabin Fire Protection rule is a case in point. Two of the elements of this proposal are improved hand fire extinguishers in passenger cabins and automatic fire extinguishers for lavatory trash receptacles. Much of the industry had already installed such equipment before the rule was even proposed; the FAA estimated that, respectively, 50 and 25 percent of the existing fleet had been so equipped. Moreover, FAA reported that these extinguishers are now regarded as basically standard equipment on newly manufactured aircraft. [6]

The regulatory remedy under consideration, in other words, serves to complement private action by filling in coverage gaps — ensuring the extinguishers are placed in more aircraft than otherwise. FAA's analysis of compliance costs correctly points out that the regulation will only impose a burden (in terms of equipment, maintenance and fuel costs) as to aircraft not voluntarily equipped. However, FAA appears to count as benefits of its regulation the lessened fire hazard in all aircraft — both those voluntarily equipped and those for which the mandate causes new costs to be imposed. This lack of symmetry in analysis of costs and benefits overstates the net contribution to safety of regulation and deflects attention from the residual role of regulation here relative to alternative remedies. Indeed it then implicitly makes less central the question of how to encourage more timely and comprehensive voluntary initiatives.

### **Valuation of Safety Benefits**

When the protection of human life is the objective, any measurement effort is apt to become more controversial than for other public policy objectives. The FAA has treated this difficult area with sensitivity and rigor and has resisted the temptation to side-step valuation questions. [7] The regulatory issue here is how far to go in the direction of securing relatively small reductions in risks facing a large number of people. That is, how much is it reasonable to spend to achieve a small incremental reduction in the risk?

Rarely can risk be totally eliminated, and rarely do we want to ignore risk altogether. This bounds the question, and invites systematic search for analytical tools to enable the decision-maker to reach tough judgment calls with greater consistency. The FAA has concluded that policy actions which lower risk enough to save one statistical life make reasonable economic sense if their cost is up to \$650,000 — so, for example, avoiding 50 fatalities by means of a regulation whose present value compliance costs is under \$32.5 million would look prudent.

The FAA has a carefully articulated derivation of this value of life, and terms it a lower bound estimate. In the years since FAA adopted its rationale, additional research results on valuation suggest that FAA probably is overly conservative and that a considerably higher value of life figure should be applied. In essence, the particular willingness to pay study at the heart of FAA's calculation reflected the risk valuation of workers having relatively high risk jobs. Subsequent research on risks somewhat more analogous to those facing airline passengers suggests that a figure roughly three times that of FAA's \$650,000 could quite rationally be applied. [8] Thus FAA's economic analyses tend to understate the benefits of regulation in this regard. At a minimum, this suggests greater use of sensitivity analysis showing implications of using various figures for the value of life.

A quite separable issue concerns the treatment of property losses in FAA benefits analysis. It surely is legitimate to regard a reduction in property damage to the aircraft as a societal benefit of a regulation. But it does seem useful to clearly separate safety benefits — reductions in fatalities and injuries — from those property loss savings that go directly to the owners of the aircraft. The reason is that, should a particular initiative have negligible safety benefits but substantial property loss savings, the logic of a government mandated regulation would seem particularly weak. Ample incentive would exist for private action to secure the optimal amount of savings. If the major basis for a rule is property loss, one might reasonably question its logic — it certainly no longer is much of a safety issue.

### **Comparison Across Programs**

While data are more extensive and reliable for some safety regulatory programs than others, efforts to make systematic comparisons of the relative effectiveness of safety regulation can contribute much toward better decisionmaking. The most obvious question to an economist is whether more lives can be saved by redirecting regulatory emphases. This is not necessarily a matter of shifting to programs with lower costs per statistical life saved (though this is always worth consideration) or higher ratios of benefits to costs. The key is the total size of net benefits, which is apt to be largest for the program that can produce the greatest total reduction in expected fatalities, so long as its cost per statistical death avoided does not exceed a reasonable benchmark value of a statistical life. Such a program may well have a lower benefit-cost ratio than that of markedly less valuable substitute programs.

But in any event, comparable data across programs are needed. Indeed, a powerful boost to better decisionmaking could be made by asking every regulatory agency to show the implicit range of cost per statistical life saved for each incremental regulatory action. As a policy matter, there no doubt are good reasons for considerable variation in these values across agencies and across types of risks, but direct discussion of such variation should be a useful spur to greater safety results.

### **Postscript**

These comments on the economics of safety applicable to cabin safety issues have been intended as general reflections on FAA's analytical approach to the regulatory decisionmaking process. Little noteworthy regulation has been promulgated of late, and cumulative assessments are not available for past actions, so little empirical comment is now possible. Perhaps the bottom line is a reiteration that thorough analysis of the benefits and costs to society of each new contemplated initiative should not be treated as an obstructionist strategem but rather as a way to ensure that the best safety outcome will emerge. Inaction when the only regulatory alternatives would be exceedingly costly per statistical life saved should not be cause for concern. A vigorous and timely research effort, fully integrated into the rule development process, is essential to enable us to distinguish prudent from unproductive regulatory activity. Administrator Engen said earlier this year that he intends "for our regulations to maximize safety to the American travelling public without inhibiting its ability to use air travel because of unreasonable added costs." [9] To that I would only note that the reasonableness of such added cost should properly be judged in relation to the amount of the lessening of the safety hazard encountered. This is the essence of the economics of safety.

## Footnotes

1. U.S. Department of Transportation, Federal Aviation Administration, FAA Statistical Handbook of Aviation, Calendar Year 1983, Table 9.11.
2. Federal Aviation Administration Regulatory Evaluation of Floor Proximity Emergency Lighting Final Rule, September 1984, pp. 3-6.
3. The key documents are:
  - Executive Order 12291 (February 17, 1981)
  - Office of Management and Budget Interim Regulatory Impact Analysis Guidance (June 12, 1981)
  - Department of Transportation Order 2100.5 (May 22, 1980)
  - Federal Aviation Administration, Office of Aviation Policy and Plans, "Economic Analysis of Investment and Regulatory Decisions — A Guide" (January 1982)
  - Federal Aviation Administration, Office of Aviation Policy and Plans, "Economic Values for Evaluation of Federal Aviation Administration Investment and Regulatory Programs" (September 1981, and June 1984 update).
4. Federal Register, October 22, 1984, pp. 41858-41924.
5. Op. cit., pp. 6-9.
6. Federal Aviation Administration Regulatory Evaluation... Airplane Cabin Fire Protection: Smoke Detector and Fire Extinguisher Requirements for Part 121 Passenger Aircraft (Project No. VS-83-324-R), pp. 26 f.
7. See in particular FAA documents dated September 1981 and June 1984 cited in footnote 3.
8. See, for example, U.S. Environmental Protection Agency, "Valuing Reductions in Risks: A Review of the Empirical Estimates," June 1983; W. Kip Viscusi, Risk by Choice (Cambridge: Harvard University Press, 1983).
9. Statement of the Honorable Donald D. Engen before the House Committee on Public Works and Transportation, Subcommittee on Aviation, August 2, 1984.



**Fred J. Emery**  
**President, Fred Emery Associates**

The rulemaking process has been the focus of Fred Emery's career for over 25 years.

First, after moving from a legal position with the New York State Government to the Legal Staff of the then Federal Aviation Agency, he participated in the FAA's recodification of the existing Aviation Safety Regulations into Uniform Federal Aviation Regulations. Then, in the late 60's, Mr. Emery served as Deputy Assistant General Counsel for Regulation of the Department of Transportation where he became involved in all of the department's transportation safety regulations. As director of the Federal Register during the 70's, he not only worked on implementing executive orders on regulatory reform but also received national attention for his efforts to make federal legal regulatory publications readable. Since starting his own consulting firm in 1980, Mr. Emery has drafted legislative and regulatory documents for several federal agencies.



## MAKING THE CURRENT REGULATORY PROCESS WORK

Many of us in this room can remember the good old days of government regulating. Twenty or more years ago regulators had to learn only the basic requirements of the Administrative Procedure Act (APA): to issue a notice of proposed rulemaking (NPRM), invite public comment, consider that comment, and then issue a final rule which stated that the comments had been duly considered. That was it. The only exception to this seemingly simple scenario was the reporting requirements of the Federal Reports Act of 1942. It didn't take long for a newcomer to learn these requirements; and once an agency had decided to take a rulemaking action, it didn't take long to issue a rule.

Times have indeed changed. A check list of current or potential requirements, compared to the requirements of 20 years ago, makes the past look like the golden age of rulemaking. The basic APA is still with us and a modernized version of the Federal Reports Act — the Paperwork Reduction Act of 1980. But today's list also includes another dozen potential requirements. Some of these requirements have been legislated, others judicially imposed, and still others are Executive branch requirements. Whatever branch of government has triggered their creation, the requirements are here to stay, and they have made the task of rulemaking far more complicated than it used to be. The following is a comparative list of 1964 requirements and 1984 requirements:

### Statutes, Executive Orders, Practices Relevant to Rulemaking

1964

Federal Reports Act  
APA  
NPRM  
Comments  
Final Rule

1984

Paperwork Reduction Act  
APA  
NPRM  
Comments  
Final Rule  
Advanced Notice of Proposed Rulemaking  
Freedom of Information Act  
National Environmental Policy Act  
Preamble  
Regulatory Agenda  
Regulatory Impact Analysis  
Hybrid Rulemaking  
Informal Record  
Sunshine Act  
Regulatory Flexibility Act  
Privacy Act  
E.O. 12291  
Ex Parte Communication  
Federal Advisory Committee Act

In addition to the above list, and related to it, the FAA must cope with an intensive review of each proposed rulemaking document within the Office of the Secretary of Transportation as well as a second level of review at the Office of Management and Budget. This double review process is repeated at the final rule stage. It is no wonder that the term "fast rulemaking" is today considered a contradiction in terms and that much time is spent within the FAA — as well as within virtually every Federal agency — looking for non-rulemaking solutions to regulatory problems.

Rulemaking has become a particularly frustrating process to many technical experts within the agency whose primary focus is to develop the best safety solution to an identified problem. The safety expert expects to identify a problem, to research potential solutions to that problem, and to select the solution that he or she considers the most viable. To the expert the legalistic, economic, and other time consuming reviews seem merely to delay implementation of sound solutions.

But there is another, more positive way to view these reforms. If we look honestly and realistically at some of the events that led to regulatory reform, we can appreciate why the new requirements exist. In addition, as rulemakers, the more knowledge we have about the various procedural requirements, the more efficiently we can comply with them and the more benefits we can gain from them for the agency and for the public. Let us look in some detail at a few of the "new" requirements:

1. *Advance Notice of Proposed Rulemaking.* This useful and at times overused regulatory technique is not spelled out in the APA nor is it judicially or otherwise mandated although its use was recommended — and almost required — in President Carter's regulatory reform Executive Order 12044. The advance notice of proposed rulemaking (ANPRM) was invented in the early 1960's, quite possibly within the FAA, as a useful way of getting the public actively involved in identifying and solving a regulatory problem at the early stages. When properly used, the ANPRM solves, or at least attempts to solve, the common complaint that by the time an agency publishes an NPRM it has actually made up its mind and is really just going through the APA motions. The ANPRM is also extremely useful when an agency is considering a major change in its regulatory philosophy. Thus, while an ANPRM is often viewed — and can be used — as a delaying device, when properly used it can speed up regulatory actions by allowing regulators and regulated to address issues broadly before either is committed — some might say "dug in" — to specifics.
2. *Semi-annual Agenda.* Under E.O. 12291 and under the Regulatory Flexibility Act, Federal agencies are required to publish in the *Federal Register* twice yearly an agenda of their active projects. The semi-annual agenda requirement (which first appeared in President Carter's E.O. 12044) had a two-fold purpose, one of which is related to the ANPRM. A common and consistent complaint from regulated industry and public interest groups is that by the time a Federal agency publishes an NPRM the game is virtually over. When testifying on proposed APA amendments some 25 years ago, one person compared the proposed rulemaking stage in most agencies to the conference committee stage in the legislative process. By the time a bill reaches the conference committee stage the legislative process is nearly complete. Thus, one important goal of initiating the semi-annual agenda was to require agencies to tell the public about rulemaking projects that were in the works, thus allowing the interested public to obtain potentially useful information at an early stage.

The second major goal of the agenda, a goal not yet fully appreciated in most Federal agencies, was a management goal. If you or I suddenly found ourselves Administrator of the FAA, we might soon conclude that our management skills were of little or no value to FAA rulemaking. We might soon conclude that even if we planned to stay around for 3-4 years (the average term for FAA Administrators since 1959 is 2.8 years), we could not have a major impact on FAA rulemaking. Why? Because to a large extent we would find ourselves a captive of the bureaucratic process. During our first month we would be faced with rulemaking documents (proposed or final) on their way to OST. We would quickly find our options limited. Virtually any question we might ask or suggestion we might make with respect to a document would likely produce a strong suggestion that unless we wanted to set the process back for many months (and most likely the document involved would already be many months overdue) we better just initial or sign where indicated.

The semi-annual agenda was an attempt to give Administrators a vehicle for identifying rulemaking projects that were already in the works, and using their management skills and authority, to make it possible for Administrators to affect the allocation of resources reflected in an agenda. To date, this management purpose has not been effectively utilized in most Federal agencies. However, the value of the semi-annual agenda as a potential management tool and as an information source for the public is gaining recognition among rulemakers and interested public groups.

3. *Ex parte requirements.* When I attended law school we were taught that the ex parte restrictions that applied in adjudicatory activities had no applicability in the informal rulemaking process — the process under which FAA rules and virtually all Federal rules are issued. The reason was simple. Ex parte was a litigation concept. One party was not allowed to talk to the judge — the decision maker — without the knowledge of the other party. Rulemaking is a legislative process. Therefore, like legislators, rulemakers could talk to, listen to, or consult with anyone at any time. Furthermore, they were allowed

and expected to draw on their own expertise and industry contacts — hence the FA Act requirement that the Administrator “shall have had experience in a field directly related to aviation.”

Unfortunately, the absence of formal *ex parte* requirements led to abuses in many agencies. Meetings were held. Drafts of documents were exchanged. Agreements were made. In the most flagrant cases the *public* rulemaking process was a fraud. The important exchanges of information all occurred outside the public record. Thus, only those in the favored group really “participated” in the rulemaking. All others were mere observers. Not surprisingly, those not included in the “in” group began to complain. Some even sued. Some won law suits. Some courts clearly went too far in imposing adjudicative-type *ex parte* rules to rulemaking. Although, we can sympathize with those judges who were appalled by the practices of some Federal agencies, the net result of the reaction to abuses is that many agencies have gone overboard in applying strict *ex parte* rules to rulemaking.

I do not think DOT is one of those agencies. The DOT order on *ex parte* contacts in rulemaking is in fact based almost entirely on an FAA order issued in the early 1960's. In short the order says that contacts are permitted throughout the rulemaking process so long as they are documented and docketed. While this may cause problems at times, we should recognize that the credibility of the FAA and the rulemaking process is important to all of us. Thus, adherence to the *ex parte* rules is important not just to prevent improper communications, but to give the overall process credibility.

4. *Preamble requirements.* Today it is hard to believe that in the 1970's the Executive branch and the Judicial branch had to force Federal agencies to write preamble type material at both the proposed and final rulemaking stage. Yet before 1972 many agencies (not the FAA) issued proposed rule documents which contained as preamble material only a statement that certain rule changes, as set forth, were being considered and that public comments were invited. The reasons for the proposed changes and the potential significance of those changes were not stated. At the final rule stage the agency would announce that a NPRM had been published, that comments had been invited and considered, and that the final rule had been changed — or not — to reflect comments received. A reader had to compare the final rule with the proposed rule to determine what changes had been made and had to analyze and evaluate on his or her own the significance of the changes.

Fortunately, the FAA (and its predecessors) have always written some sort of explanatory preamble, however minimal it may have been in the 1940's and 1950's. For anyone who must research the history and foundation of current regulations that preamble material is invaluable. While we have all seen preambles that tell us more than we want to know, I doubt that any of us would wish to eliminate this valuable source of information.

5. *Impact Statements — Economic, Paperwork, Small entities, etc.*

The number of “impact” statements now required before a rulemaking document is ever published in the *Federal Register* is probably the worst scourge of rulemakers. There is little doubt that “reform” in this area has made fast (efficient) rulemaking very difficult — sometimes virtually impossible — to achieve. Yet, if we pause for a moment to consider the alternative — the “real world” rulemaking of some agencies prior to the reforms — we can understand the justification for these requirements.

Let's look first at the National Environmental Policy Act (NEPA) and its requirement of an environmental impact statement. Just for a minute imagine that the area in which you live has no zoning requirements. Do you want a glue factory or a pig farm next door to your house? Extreme example? Maybe. But regulating without considering environmental impact is analogous to living in an area without zoning laws. Consider the position taken by the Atomic Energy Commission (AEC) before the National Environmental Policy Act (NEPA). AEC maintained that the only environmental issues it was required to consider were those of a radiological nature. Thus, AEC maintained that a nuclear reactor that spewed out millions of gallons of hot water killing all fish in the receiving body of water was not the agency's concern. The Supreme Court agreed. Congress did not. AEC fought to be exempted from NEPA and lost that fight in Congress. AEC then narrowly interpreted NEPA so that it would not have to change its previous practices. This time the courts disagreed (the case never reached the Supreme Court).

On the subject of economic impact statements, one sometimes gets the impression that before President Ford issued his first regulatory reform Executive order on "inflation impact statements" in 1974, no rulemaker ever took economic factors into consideration. Admittedly, in the area of safety regulation, consideration of "cost" has always been particularly sensitive. No safety regulator wanted to be caught equating dollars with lives. Yet it is absurd to say that before 1974 costs were not considered. Of course they were. But not up front.

Consider for example automobile safety regulations. Soon after the National Highway Traffic Safety Administration (NHTSA) was established, NHTSA knew how to mandate design of a virtually injury proof car. My recollection is that NHTSA (no doubt with considerable help from Detroit) had on paper an automobile design that would have allowed all occupants to walk away injury-free from a head-on crash of two automobiles each traveling at 40 mph. If everyone drove such an automobile, 50,000 lives a year could be saved and several hundred thousand serious injuries avoided. The dollar savings would be in the billions. Yet almost 20 years later no such automobile is available because its cost is too great. My recollection is that in late 1960's each such automobile would have cost about \$25,000 (about \$76,000 today). In short, had NHTSA mandated such a design, it would have eliminated the automobile industry as we know it. NHTSA may never have published a document discussing the tradeoffs between costs and lives saved, but clearly it considered costs in its design decisions.

While it is unfair to assume that we didn't have to consider costs in the halcyon days before reform, it is also unfair to assume — as many economists appear to — that cost considerations alone can and should drive every regulatory decision. Regulations are legislative documents. As in Congressional enactments, a large element of judgment is involved, and there are times when a regulatory decision maker — the FAA Administrator or any other — must trust his or her judgment to act or not act without regard to a strict cost/benefit analysis. Congress probably could not justify the 55 mph national speed limit (or many other of its decisions) on a cost/benefit basis to satisfy the purist economists. Safety regulators should not be held to artificial standards that go against their common sense and good judgment. But, they should recognize that rulemaking decisions cannot be made without reference to the cost implications.

This brief look at a few regulatory reform activities shows that although rulemakers often perceive a requirement as an obstacle, proper compliance with the requirement benefits the overall process. If all goes well, we end up with better rules. In addition, if all goes well, we may end up with fewer rules. The many steps required to publish a final rule cause rulemakers to think twice before deciding if rulemaking is the proper course, or if a better solution to the problem might be found, at least temporarily, somewhere else.

An agency can use a number of methods short of rulemaking or prior to rulemaking to resolve problems. These methods include issuing advisory circulars, notices, operations bulletins and other such documents. An obvious advantage to these less formal methods of regulating is that they do not require the full chain of review that rulemaking requires. A major disadvantage is that these documents are not enforceable rules. Nonetheless, rulemakers are often tempted to use one of these less formal documents, not because circumstances prescribe their use, but to avoid the full rulemaking review process. While this temptation is understandable, regulators should think twice before taking the easy way out. If an enforceable rule is needed, then an enforceable rule — not advisory material — should be issued.

Whatever method an agency uses to regulate, it should recognize the basic goals of regulatory reform: that the action taken by the agency be appropriate and be in the best interest of all of the public. In the "real world" of regulation many players are involved: the agency's technical experts, lawyers, drafters, and economists; plus policy and other reviewers within the agency and at OMB; plus persons outside the government within industry and public interest groups. It is important for each player — particularly the technical experts — to recognize that identifying the right regulatory solution to a problem is of no benefit if that solution is never implemented. This means that the technical safety experts must be aware of the needs of the lawyers, the economists, the policy makers, etc. No matter how right the technical expert is, it is not sufficient for him or her to say, "This is the right fix, take my word for it."

An example, of how an agency can attain maximum coordination among all players to assure the best possible rule is the FAA's recent efforts to improve its regulations on flight time limits in 14 CFR Part 121 and Part 135 (the number of hours an air carrier may schedule a pilot to fly). For years, the flight time limit regulations have been a source of numerous requests for interpretation and have led to numerous legal controversies, but each time the FAA issued an NPRM proposing changes to the rules, the agency was inundated with comments objecting to the proposal. To resolve the controversy, the FAA initiated a rulemaking process called Regulation by Negotiation. In short, Reg Neg brought representatives from the affected parties together with agency representatives to negotiate a rule. Instead of the notice/comment approach, which tends to intensify rigid positions towards a rule and casts the agency in the role of proposing an "acceptable" resolution which can survive the review process, Reg Neg provided a forum where the affected parties came together to hammer out an acceptable solution. The process required several meetings between June 1983 and September 1984 during which positions that were initially diametrically opposed moved closer together. The range of alternative options narrowed, and the FAA issued a proposed rule in March 1984 and intends to issue a final rule early in 1985. Clearly the process was no fast lane, but for regulations that had remained virtually unchanged for 30 years despite numerous problems with interpretation and enforcement, Reg Neg appears at this point to have produced great strides towards resolving a long-standing problem.

The collective efforts of this cabin safety conference where technical experts in the agency, industry experts, and passengers have been brought together to exchange information also illustrate a particularly commendable type of regulatory reform. No one agency could possibly have all the necessary resources and data to determine what is best for everyone, but by teaming resources to include the technical expertise of the agency, industry, and public interest groups, the rulemaking process can be made to work more efficiently. This increased efficiency need not be frustrated by the various impact statements and levels of review that must follow. Rather, the deliberations of the working groups can serve to provide a solid basis to those who must draft the regulatory documents. Therefore, we all must address rulemaking — both substantively and procedurally — as a problem solving process. If we identify acceptable and justifiable solutions and if we document those solutions, we will find that the regulatory process can work efficiently. The "R's" of Regulatory Reform need not stand for "Roadblocks to Regulations."



**Edwin I. Colodny**  
**Chairman and President, USAir Group, Inc.**

Edwin I. Colodny joined USAir in 1957 as Assistant to the President. Subsequent positions included Secretary, Vice President - Legal Affairs and Economic Research, and Senior Vice President - Legal Affairs and Economic Research.

In 1969 he was elected Executive Vice President - Legal Affairs and Marketing Services with responsibility for all customer services, inflight services, and station operations. He held this position until 1973 when he was named Executive Vice President - Marketing and Legal Affairs, a position that included the direction of the company's advertising and sales promotion programs.

He was appointed President and Chief Executive Officer and elected to the Board of Directors in July 1975. In May 1978 he was elected Chairman of the Board of Directors and President of USAir.

Colodny is a Trustee of the University of Rochester, and a Director of the PNC Financial Corp., the Pittsburgh National Bank, Gulf Oil Corporation, and the United States Chamber of Commerce.

Prior to joining USAir, Colodny was affiliated with the Office of the Judge Advocate General as a First Lieutenant in the U.S. Army and was a trial attorney with the Civil Aeronautics Board Bureau of Air Operations.

Colodny received the National Transportation Award for 1983-84 from the National Defense Traffic Association, was named 1984 Chief Executive Officer of the year for Regional Airlines by the *Wall Street Transcript*, was named *Washingtonian Magazine* Businessman of the Year for 1984, and has received the *Financial World* Airline Chief Executive Officer of the Year Award for 1981, 1982, and 1983.

He is a native of Burlington, VT, and received his A.B. degree with distinction in 1948 from the University of Rochester. He earned his LL.B from Harvard Law School in 1951.

## LUNCHEON ADDRESS

Edwin I. Colodny

As I walked through the lobby I saw an awful lot of luggage. I hope those of you traveling home today on airlines are planning to take that load as checked baggage.

We all are here because we are interested in safety — safety first, second, and third. This meeting provides an excellent forum for bringing everyone together for frank discussions.

Yes, the air travel industry has a good record and the airlines achieved this record because of their concern for safety. Air travel is safer than ever before. And, in the period since deregulation in late 1978, a period when the naysayers thought competitive pressures would cause air safety to decline, the airlines' safety record is second to none. In the six-year period since Deregulation, we've had the lowest fatal accident rate since jet operations began in 1958.

That is an exemplary record.

Let us give credit where credit is due. The credit goes to the experts. There are two general categories of experts.

The first category are those who are expert in building, operating, and manufacturing the airplanes, namely the manufacturers and the airlines.

The second category are those responsible for regulation, research, and development, namely the Federal Aviation Administration, the National Transportation Safety Board, NASA, and private sources.

Together, this combination of manufacturers, airlines, and government agencies has produced the finest and safest air transportation system in the world. And we are *all* committed to continuing this record.

Airlines demonstrate this commitment several ways — through the acquisition of modern, more efficient aircraft, through maintaining high — and continually improving — standards of maintenance, and through rigorous training programs.

*Aircraft.* Today there are some 450 new aircraft on order by the U.S. scheduled airlines. These aircraft have state-of-the-art navigational aids, new weather radar, and sophisticated flight management systems. The technology available in today's jets is a generation away from aircraft built just eight years ago.

The airlines are re-equipping. USAir, for one, has acquired 65 aircraft since airline deregulation became law, late in 1978. Two of those 65 are the new technology Boeing 737-300. We have 28 more of this modern twin-jet on order, bringing our total commitment to recent aircraft acquisition to over \$1 billion. By the end of this year, 61 of USAir's 129 jets — or 47 percent — will have been built in 1979 or later. By the end of 1987, 91 of a planned fleet of 147, or 62 percent, will have been manufactured since 1979.

*Maintenance quality.* In spite of the economic pressures on the airlines in the period following airline deregulation, the quality of maintenance has improved. In fact, the quality standards of the deregulated marketplace have dictated maintenance programs that are more stringent than those contained in the Federal Air Regulations.

In addition, in this competitive environment, the maintenance and engineering functions are more important than ever. This is not only due to the need for increased reliability because of greater competition, but also because of the need for flexibility in scheduling. We must be able to redeploy our resources quickly and efficiently. These higher standards produce safer and more reliable aircraft.

One last thought on maintenance quality: it cannot be competitive. On safety matters, competition must be put aside and we must continue to talk and work together.

*Training.* The airlines invest a lot in training employees — in initial and recurrent training. Most all of the training centers around safety. Pilots train intensively, and with the new flight simulators, they are able to train for emergencies and the not-to-be-expected situations. Over half of the flight attendant training

program is on safety issues and procedures, and ultimately, all of the maintenance training focuses on safety. All of the airline training programs are approved by the FAA.

It works well, this relationship between the FAA and the airlines. FAA sets the objectives, we determine how to meet them. FAA provides the challenge; the airlines in concert with the manufacturers decide how to meet it. It is the proper balance. We are the experts in operations and training; striving to meet FAA objectives and guidelines assures we continue to have that expertise.

As Congressman Mineta said in his keynote remarks on Wednesday the safety levels today are acceptable. However, he added a "but" and that was, but, the public wants more progress.

So do the airlines.

We want to make improvements that will make travel safer, and we are prepared, to use the expression, "put our money where our mouth is."

But there is more to it than money alone.

We cannot throw dollars at problems. Before investing the time and money needed to make changes we need to see that the changes will make a significant difference. For the changes that have been demonstrated to provide improvements, yes, the airlines will invest in them. For example, the value of portable halon fire extinguishers was demonstrated. We needed no convincing and legislative mandate was not necessary. Airlines started installing portable fire extinguishers two years ago and have almost completed the task.

But in other instances of changes for safety's sake, many appear to be rushing down the regulatory road without paying attention to the traffic signals. This is not an area for hasty decisions. The airlines and manufacturers rely on the government — with its great resources — to do development and testing, and much research, testing, and evaluation needs to be done before a new material, technique, or procedure is adopted.

We need to be absolutely sure that only good and not harmful side effects will result. Some of the suggested improvements have not been fully tested and their benefit, if any, is unclear. Anti-misting kerosene, or AMK, is a recent example. While the airlines support such research and development efforts, considerably more research on AMK and its use in commercial aircraft needs to be done. Extensive testing in a whole range of worldwide operating conditions will be necessary.

Such testing and evaluation is needed for a range of the current suggested changes. For example, fire retardant materials. We need materials that don't burn, don't smoke, and don't put out toxic materials. That means more research and testing.

As I've said, the airlines can only adopt programs after they have been demonstrated to be feasible improvements, and to be meaningful improvements for the money invested.

I have a suggestion. The airlines must take a more active — *and visible* — role in the development, testing, and evaluation of new materials and procedures. We have long been part of the process. Many of the projects talked about this week have been under study for years — cabin safety is not new — with airline technical people working with the manufacturers and the regulators.

We need to set realistic and achievable goals; realize that improvements are evolutionary, not revolutionary — they take time and study; and we need to be clear in our response on safety issues. The airlines need to continue to take the initiative on safety. Much of this will be through the Air Transport Association, which is taking an increasingly responsible role on behalf of the airlines on operating matters.

What has been called the three-legged stool — airlines, manufacturers, and regulatory agencies — needs to continue to communicate, cooperate, and remain committed to better safety for all.

I would like to conclude by making a few observations that I as a CEO think need to be said.

My role here today is not to resolve the issues that have been raised in your seminar, you're better at doing that than I am. But, I would offer these thoughts as a background against which we evaluate changes.



First, let me say that I believe that deregulation is not served by letting everyone into the business. I suggest that it is time to re-examine the standards of fitness. We have gone through six years of opening the door wide and I believe the CAB and the FAA have a joint responsibility to clearly redefine what it takes to become a scheduled airline operator. I think that we all know that regulation is only one leg of the stool. A very important leg of the stool is compliance and the capability of the organization, the entire organization, which means the management, the board of directors, and employees.

Secondly, the pressures to lower the price of air travel inevitably put pressure on the degree and speed of improvements. We have older aircraft flying longer. They are flying longer because that is the way you get into the business. Buy an older airplane, fly it and hope that you don't have a problem before it gets to its next check.

We have an inherent conflict between competition and safety improvements. The pressure is for lower ticket prices. I dare to say that the federal government, from the White House on down, has had a bias toward new entrants, particularly toward new entrants who promise to fly people for nothing. I am absolutely amazed that I pay \$20, \$30 to take a cab ride from Dulles Airport to Washington and somebody expects me to provide a modern jet to fly from Pittsburgh to New York for \$29. There is something wrong when our sense of values puts so much emphasis on price that we lose sight of other objectives. If the public wants price, there is going to be a price to pay for it — whether it be in the modernization of the system or somewhere else.

I am not against flying old airplanes. The point I want to make is that whatever improvements are decided upon by the industry, regulators, or legislators, the individuals who buy the product ultimately have to pay for it. It has got to come out of the ticket price.

Another observation is on how airline safety should be treated in the media. I think of all the stories that have appeared recently in the press and there needs to be a balance. We have a safe system, let's not create the impression that it is unsafe. Writers seem to like to redo accident history, to go back years and repeat previous incidents all over again. I have to question whether the need for instant news on TV in some way is not warping the issues as they really are. The Aviation Space Writers Association handbook has a statement in it that I would repeat: "Accidents often have complex causes. Hence, the golden rule of accident news coverage is identical to that of accident investigation. Don't jump to conclusions."

The final point I would like to make is this: while your forum is on cabin safety, I believe the real priority should be on rebuilding our airport/airways system. We should start spending the ADAP money. There is a \$3 billion surplus in the aviation trust fund. I fear it is going to get caught in the budget freeze. Either we spend this money and do it properly, or, let's give the customer back his 8 percent we are charging him on the ticket. Let's give it back to him and not fool him by telling him we are taking it out to support something he isn't getting.

Everybody in this room has an obligation in the days ahead to speak loudly and clearly to the Congress, the Administration, the Department of Transportation on that issue. We cannot afford to lose two, three, or four more years in doing the upgrading that is required. Don Engen knows, as he has said many times, we won't solve all these problems simply by adding air controllers. We need concrete, we need a lot of things. I hope we get on with that job real soon.

A final word to those of you who are in this business — we need you.

Thank you very much!

## SUMMARY OF WORKSHOP DISCUSSIONS

The following summaries contain comments which were voiced during each of the three workshop sessions. All comments are non-attributable, by previous agreements, so that there would be less reluctance to present personal, controversial, and possibly more sensitive views which would not otherwise be encouraged in such forums.

There has been no attempt to present any FSF opinions in this section, but to present, for the reader's benefit, only those topical areas and the resulting comments provided by the participants of each workshop.

An FSF analysis is presented in the section immediately following. (Combined Analysis of Workshop Discussions.)

### INFLIGHT OCCUPANT PROTECTION WORKSHOP SUMMARY OF PROCEEDINGS

Chairman: Peterlyn Thomas; Cabin Safety Manager, Ansett Airlines

The Inflight Occupant Protection Working Group met to discuss hazards associated with inflight turbulence, fires, and medical emergencies. In addition to the foregoing subjects, considerable discussion was devoted to food and beverage cart design, carry-on-baggage stowage, child restraint systems and the carriage of the handicapped. The following summarizes the discussions:

#### **Inflight Turbulence**

A number of subjects were discussed relating to the hazards of inflight turbulence and suggestions were made on how to minimize these hazards. A significant problem during turbulence stems from the carry-on-baggage in the passenger cabin. During turbulent flight the overhead baggage compartments can open and spill their contents.

Some air carriers are ordering airplanes with larger overhead baggage compartments. Passengers are thus encouraged to carry their baggage rather than check it through. It was pointed out that if more baggage is carried on by the passengers, fewer baggage handlers are required by the airline, and more cargo space is available for shipment of paid cargo.

Although the overhead baggage compartments are placarded for a maximum permissible load, the weight of the baggage which is placed in the overhead is unknown. One suggestion was to have a portable scale aboard the airplane to settle any disagreements regarding baggage weight between the passenger and flight attendant. On overseas flights which have a baggage charge for overweight luggage, passengers tend to carry on heavier luggage and check through the lighter pieces of baggage.

The Association of Flight Attendants (AFA) has petitioned with the Federal Aviation Administration (FAA) to initiate new regulations to limit the amount of carry-on baggage permitted aboard the airplane. The Air Transport Association (ATA) has recommended that the problem be handled within the existing regulations.

Quite a number of the workshop participants recommended that the airlines standardize their policies with respect to carry-on-baggage. It was pointed out that the passengers become confused when one air carrier permits almost anything to be carried aboard while the next carrier requires the baggage to be checked through. It was also suggested that the boarding agents should stop passengers from carrying excessive baggage aboard the airplane rather than leave that task to the flight attendant.

Two additional suggestions were made regarding the carry-on-baggage problems. One, that the cabin crew should tell the passengers of the hazards associated with the failure to stow carry-on baggage which

would result in peer pressure by passengers to encourage that the baggage is properly stowed by others. Secondly, the air carrier could encourage the passengers to check their baggage by providing more efficient and rapid baggage claim at the destination.

Turbulence can also result in hazards to cabin occupants from food and beverage carts. One manufacturer pointed out that if the cart's "mushroom" attachment is engaged properly, the cart will not move during turbulent flight. The flight attendants responded that the tethering of the carts is difficult and that the carts are not always maintained properly, so they cannot always secure them. From a maintenance standpoint, it was noted that the air carrier's maintenance department is not always informed that there is a problem. It was suggested that improved communications between departments within the carrier's organization would do much to relieve the problem of the flight crews' inability to secure the food and beverage carts.

One manufacturer pointed out that they have designed and sold a four-point harness tie-down attachment for food and beverage carts which can be attached to the passenger seats in the event of inflight turbulence. Another pointed out that they have ordered airplanes with "mushroom" attachments for carts not only in the galley area but placed periodically along the passenger aisles. A placard on these carts states that they must be secured when unattended.

It was the consensus of the participants that better forecasting of turbulence, improved weather briefing of cabin flight attendants, and better communication between the flight deck crew and flight attendants would also do much to reduce the inflight turbulence hazards.

## **Inflight Fires**

There was considerable discussion of catastrophic in-flight aircraft fires. The fatal inflight fire which broke out on a Varig Airlines B-707 July 11, 1973 was attributed to a discarded cigarette in a lavatory waste paper disposal unit.

The nonstop flight from Rio de Janeiro to Paris had progressed without incident until a passenger reported smoke in the lavatory shortly before its scheduled landing at Orly Airport near Paris. Within four to six minutes, a fire in the aft lavatory caused thick, black smoke to fill the cabin and cockpit. Unable to see their instruments, the pilots opened the sliding windows of the cockpit and put their heads out in order to make a forced landing in a field 4 miles from the airport. Of the 135 occupants on board, ten crew members and one passenger survived. The remaining 124 persons died from asphyxiation or the effects of toxic gases.

Another accident occurred in Riyadh, Saudi Arabia on August 19, 1980. A Saudia Airlines Lockheed L-1011 with 301 passengers and crew on board made an emergency landing after reporting an inflight fire. The aircraft landed normally and then taxied for several minutes before coming to a stop. No one inside the plane opened any of the doors and all 301 persons perished. Following an in-flight fire aboard an Air Canada DC-9, on June 2, 1983, a successful landing was made in Greater Cincinnati Airport, Kentucky. Twenty-three of the 46 occupants who were overcome by smoke and toxic fumes could not evacuate the airplane and died in the ensuing fire.

It was pointed out that the statistics on inflight fires are somewhat inconsistent. In one of the conference papers, United Airlines reported that it has had about sixty incidents, over a four-year period, while NTSB data contains only forty fires in the last ten years. A spokesman for one airline insisted that the FAA gets all of their reports.

It was suggested that criteria be established for reporting inflight incidents of fires and hazardous smoke. Even though the definitions would be somewhat restrictive, the carriers could still have their own criteria for reporting by the crew. One participant suggested that everything be reported and that the categories of incidents could be broken down into sub-groups. There was no suggestion as to which organization would be responsible for storing the data reported.

One airline allegedly reprimanded a flight attendant for reporting an incident directly to the FAA rather than going through channels. This suggests that the carrier may not have reported the incident to the FAA had the flight attendant gone through the company channels.

There was considerable discussion on the method of protecting the cabin occupants in the event of an

inflight fire. In 1960, the FAA issued a Notice of Proposed Rule-Making (NPRM) to require smoke hoods for air carrier passengers. This hood was designed to protect the passenger for two to five minutes in the event of a post-crash fire. After tests were conducted, the NPRM was withdrawn, primarily because of the difficulty and excessive time in donning the hood. This hood would not be effective in protecting cabin occupants during an inflight fire because of the limited air volume. It was pointed out that a hood is presently available which contains an oxygen generating candle which supplies oxygen for fifteen to seventeen minutes' time. It was stated that this type of hood requires special training for its use and therefore would not be recommended for passengers but could be used by the flight attendants. Other hood-type masks were mentioned such as one that can be attached to the oxygen system, the air conditioning gasper type, and filter-type hoods. For discussion of these hood types, see the paper by James J. Brenneman, presented during Session III of these proceedings.

It was suggested that an Advance Notice of Proposed Rulemaking (ANPRM) be issued by the FAA so that industry could come up with what is available in the area of rebreather equipment for passenger protection. Objection was voiced to this proposal since the FAA already has a research project looking into this subject.

It was the consensus of the participants in this workshop that the best protection for the cabin occupants, in the event of an inflight cabin fire, is to land the airplane as soon as possible and evacuate the occupants.

A suggestion was made that wet hand-towels to cover the nose and mouth may be of help in the event of an in-flight fire. It was proposed that the carrier provide a wet cloth in an airtight plastic bag in each seat back. In the Air Canada accident, wet hand-towels were used by the passengers but the effectiveness of the towels was questioned by some in the meeting. The towels were handed out to the passengers seated in the first few rows of the airplane while the majority of the occupants that survived were seated just forward of the overwing area.

It was suggested that the best fire detector is the human nose. For those fires occurring in the cabin, a simple smoke detector is also helpful, but more dependable detectors are needed for fires in inaccessible areas. Two vendors are presently developing smoke detectors for use on aircraft.

It was suggested that many inflight fires, such as seat and lavatory fires, are minor in nature and easily controlled by the cabin crew. The problem is the hidden fire which becomes well developed before it is detected and cannot be extinguished because of its inaccessibility.

Inflight fires present two problems: containing or extinguishing the fire, and ventilating the airplane. Unfortunately, these are conflicting problems. Ventilating the airplane provides oxygen to the fire and increases its intensity. Without ventilation, the effect of smoke and toxic fumes in the cabin may be increased. It was suggested that the solution to this problem is within present technical capabilities.

## **Inflight Medical Emergencies**

The discussion centered around the emergency kits aboard the airplane, what medical assistance flight attendants can provide passengers, and the training received by flight attendants to handle inflight medical emergencies.

The Canadian air carriers carry a physician's kit aboard each aircraft. It is estimated that at least one physician is on board seventy-five percent of all flights. Although litigation might result from the treatment of a passenger in flight, it was stated by one participant that the air carriers in Canada assume any liability by designating the physician as a temporary company employee.

It was pointed out that passengers readily accept treatment during the inflight emergency but may file suit afterward. In many cases doctors refuse to provide medical assistance in flight because of liability aspects. A recent proposal presented to the U.S. Congress was intended to protect the physician in such situations; however, it has not been adopted.

It was reported that the FAA is developing an NPRM for an improved emergency first-aid kit to be carried on all U.S. air carrier aircraft.

Medical training for flight attendants was reported to be rather limited. It was proposed that the flight

attendants should receive a standard Red Cross first aid course with CPR training. It was pointed out that about eighty-five percent of the air carriers already provide some CPR training for flight attendants. It was suggested that there is insufficient time during recurrent training to provide the necessary medical training such as CPR and first-aid.

An article entitled "Emergency Medicine and the Airline Passenger" published in *Aviation, Space, and Environmental Medicine*, September, 1980 provides information on inflight emergencies and describes some simple and effective first-aid and CPR techniques suitable for inflight operations.

### **Food and Beverage Cart Design**

It appears that there is very little consideration in the design of the cart to human capabilities. It was suggested that the manufacturers, operators, and users (flight attendants) should collaborate on a design which would provide for easy and safe use by the flight attendants. A British representative indicated that they buy their carts from two European companies and said that they have considerable input in the design. Some U.S. operators buy from the same companies but provide much less input on design. It was suggested that the SAE develop proposed standards for these carts.

One participant indicated that poor cart design has resulted in back and arm problems for flight attendants. The hand braking mechanism, a horizontal bar which has to be pushed down to release the brake, has caused lower arm problems among some attendants. The problem has been diagnosed as "carpel tunnel syndrome." The first indication of the problem is tingling in the fingers and numbness. The second stage is loss of grip.

One flight attendant said that her airline had a cart with a foot brake. It has two pedals; one for "go" and one for "stop." If you step on the brake, the cart will not move. To date, the attendants with this airline have had no problem with carpal tunnel syndrome. More data is needed with regard to this medical problem before a solution can be found.

Regarding cart tie-down, one participant indicated that they have a single point attachment on their carts and a clip in the galley area for its attachment. This clip can also be attached to the passenger seats while serving; however, this seat-clip method is only practical if it is conducted prior to a turbulence encounter.

### **Carry-on Baggage**

In addition to the previously discussed problems of carry-on baggage from the standpoint of turbulence, there was a great deal of discussion specifically concerning the amount of such baggage and the problem of its stowage.

It was suggested that there should be a common standard among the airlines so that the passenger will know what can be taken aboard. Often passengers will be able to take certain items on one airline but will not be able to do so on another. It was suggested passengers be limited to two bags, each of which can fit under a seat. Excess cabin baggage should be disallowed prior to boarding. Frequently the last minute passenger shows up with excess carry-on baggage and is permitted to board, leaving the stowage problem to the flight attendant. One air carrier representative mentioned that they have a sizing gage at the ticket counter to determine if the luggage can go under the seat. If it does not meet the proper dimensions, the passenger will not be allowed to carry it on board.

One individual suggested that only hats and coats be permitted in the overhead bins. Another suggested that a baggage closet be installed near the entrance door so that passengers could leave their bags as they entered. This suggestion was opposed by the group since it would accommodate probably only the first quarter of the passenger load, leaving the remaining three quarters with nowhere to stow their baggage.

Some carriers' solution to the problem of carry-on baggage has been to provide large overhead bins. Many carriers recognize the limitation on the weight of luggage permitted in these bins and have conducted considerable testing to assure that they will meet design requirements. Some carriers solicit the input from the cabin crew with respect to suggestions for improvement of cabin interiors.

The attitude among the flight attendants in this workshop is that there will be no change in the situation regarding carry-on baggage unless regulations are promulgated.

During an emergency, passengers attempt to take their personal belongings with them, thereby interfering with a rapid evacuation.

### **Child Restraint Systems**

The FAA has recently approved, for aircraft use, those child restraint seats certified by the National Highway Traffic Safety Administration (NHTSA) for use in automobiles. The participants indicated that they have difficulty knowing which seats have the NHTSA approval. Usually the model number is on the bottom of the seat and the approved list is in the flight attendants manual.

The flight attendants believe that the seat should be checked by the ticket agent before it is permitted to be carried aboard. Even though it is an approved model, it may not be in proper condition to provide restraint.

It is anticipated that there will be an increase in child restraint seats carried aboard the aircraft. Parents are becoming more aware of child restraints particularly since many states require children to be restrained in automobiles.

It was agreed by all participants that an easily identified standardized marking should be affixed to the approved child restraint seat.

### **Carriage of the Handicapped**

The airline sets its own policies with respect to handicapped persons. Basically it is a problem of educating the handicapped for their protection in an emergency as well as for the protection of the other passengers. The ATA has assisted in an educational effort by working with the "Access to the Skies Program", which is devoted to making commercial air travel more accessible to the elderly and disabled.

### **Other Areas of Discussion**

A brief discussion was held regarding the brace position with an infant on the passenger's lap. Most agreed that the best procedure is to relocate the family to the bulkhead row if there is time. Wrap infants in blankets and place them on the floor against the bulkhead.

The question of oxygen masks on the airplane was raised with respect to an additional child in a row of seats. It was pointed out that the carriers are required to have ten percent additional oxygen mask installations. The location of these additional masks may not be known. It was suggested that a placard be placed on the outside of the oxygen mask compartment so the flight attendant would know where additional installations are located.

It was pointed out that there is presently no consideration for the effects of flight attendant fatigue. It was proposed that standards be established for flight and duty time for flight attendants.

It was also suggested that the FAA issue a bibliography of cabin safety material which would contain a short synopsis of each publication. This would facilitate research into cabin safety problems.

# CRASH AND FIRE PROTECTION WORKSHOP SUMMARY OF PROCEEDINGS

Chairman: Doug Clifford, Boeing Commercial Airplane Co.

The Crash and Fire Protection Workshop was dominated by the subject of post-crash fire protection, particularly the proposed aircraft seat cushion flammability requirements and the forthcoming Notice of Proposed Rulemaking (NPRM) on flammability standards for aircraft cabin interior materials, including side walls and ceiling panels. The proposed rules on seat-cushion flammability were published in October 1983 and call for all seat cushions in the jet air carrier fleet to comply with the new standard within three years after the effectivity date. The proposed NPRM on cabin interior materials was scheduled for release for Executive Branch coordination by the end of December 1984 prior to publication as a NPRM. The NPRM will provide for a three-month review and comment period prior to further action by the FAA. Seat fire-blocking and cabin interior materials were generally discussed concurrently, although they have been treated separately by the FAA for regulatory purposes.

Another subject of extensive discussion was airframe structural integrity and design criteria for occupant survival. The FAA has indicated that it expects to have completed sufficient research and testing by June 1985 for publication of a NPRM covering improved seat-strength standards based on up-dated transport aircraft crash load modeling techniques and crash scenarios.

## Flammability of Cabin Interior Materials

Workshop representatives from the airlines expressed concern over the probable far-reaching implications of the proposed NPRM on cabin interior materials. The costs for modifications covering interior materials to the aircraft fleet represented by the Air Transport Association (ATA) was estimated to range from 250 million to one billion dollars, exclusive of the value of the lost utilization of the aircraft due to the time required by the modifications. Most airlines now schedule 10-day periods for major maintenance which would be the only time available for cabin interior modifications. Any additional down-time would result in lost aircraft utilization and revenue production. A time scale of three years for fleet modification would be almost impossible to meet, whereas a 5-7 year timetable would be more realistic and a 10-year period for compliance would have little impact on utilization. The cost of compliance with the proposed new seat cushion flammability rules was stated to be between 40 and 50 million dollars.

The need for closer industry/FAA coordination and cooperation prior to formal action on rulemaking was emphasized. By the time an NPRM is issued, opinions on the issues will probably have been formulated, and basic changes to the proposed regulations would not be likely. Involvement of new technologies and far-reaching implications in many of the regulatory areas may force affected parties to spend considerable time and effort to develop meaningful and timely responses to NPRMs. The issuance of an Advance Notice of Proposed Rulemaking (ANPRM) was described as a useful means for involving the public in the early stages of rulemaking activity, when changes are readily made and often expected. Continuing coordination and contact among technical personnel ensures that the interests of all affected parties are considered. The FAA repeatedly indicated that it welcomes and solicits this sort of participation by industry and the public in its technical activities.

There was much concern expressed by workshop participants as to their lack of knowledge of the details of the forthcoming NPRM on interior materials. This is because FAA rulemaking procedures do not permit discussion by the FAA of proposed regulations except with public notice and opportunity to participate. It was pointed out that although the aircraft manufacturers and airlines are primarily affected by the proposed rules, the flying public, airline employee groups, and the other elements of the air transportation industry have legitimate interests and concerns, and desire to participate in FAA rulemaking activity.

Several of the workshop participants criticized the proposed flammability rules both as to seat blocking and interior materials suggesting that the FAA action was politically forced as a result of congressional pressures. The FAA countered that the timetables for most of the scheduled rulemaking had been

established prior to recent Congressional hearings, and that the timing is coincidental. Comments by the public on the NPRM on seat-cushion flammability have not reflected this concern and most participants considered the proposed regulation to provide significant safety improvement.

The three-month time period for public review and comment on the NPRM on interior materials was considered inadequate according to several workshop participants because of the complexity of the required aircraft modifications, and the lack of available information concerning the detailed requirements. Also, this NPRM may be published at the same time as a number of other cabin-safety-related rule-making actions are under consideration by the FAA. These considerations may prevent compliance by the aircraft manufacturers and airlines with the three-month deadline, and an extension of time to submit comments on the NPRM will undoubtedly be requested.

It was also stated that much of the data comprising the technical justification for the proposed interior materials flammability rules have not been reviewed in detail by the industry, although industry has participated extensively in the research and test program planning and development. Also the industry has participated in testing to evaluate new and improved test procedures and to determine repeatability of test data and to develop predictive techniques and methods.

The technical justification for the proposed aircraft cabin interior rules was questioned. An industry study is currently under way utilizing aircraft accident data. It was mentioned that from the information available it does not appear possible to determine the contribution of the seats and interior materials on the probability of fatalities from inflight fires. These data indicate the dominance of fuel fire as the cause of fatalities, and provide the basis for the consequent dissatisfaction with the FAA test scenarios leading to proposed new standards on flammability of seat cushions and cabin interior materials. The report of this study is not yet available, but was promised to the FAA when completed.

It was acknowledged that seat fire-blocking layers will provide protection against the spread of inflight fires, even though the fire scenarios are not known. It appears prudent to the industry to adopt seat fire-blocking standards now, especially in view of the relatively moderate cost of compliance. Due to the present uncertainty with cabin interior fire scenarios and the contribution of other cabin interior materials to the fire problem, research and testing on further improvements should be continued by the FAA with industry participation and cooperation.

Minimum fire safety standards for interior materials should be developed and new improved materials should be required for installation in new production aircraft if costs are not significantly increased by the requirement. It was suggested that interiors complying with the new standard should be retrofitted on a routine, non-interfering basis in existing aircraft.

The FAA expressed strong disagreement with the statements concerning fire scenarios and the relative contribution of various interior materials to fire fatalities. Approximately five years ago, the Special Aircraft Fire and Explosion Reduction (SAFER) Advisory Committee recommended an extensive program to the FAA to study the role of materials in post-crash cabin fires. Subsequent testing has shown that, in certain fire scenarios, interior materials have been the dominant factor as the cause of fatalities. This has been verified by accident records. Cyanide and other toxic chemicals which result from flammability of polymeric materials have been found in victims. Certainly, fuel fires predominate as the major hazard in post-crash fires but interior materials have also been the dominant factor in some cases. This would be especially true in cases where the intact aircraft shell and interior panels inhibit the spread of fuel fires.

The problem of inflight fire safety is presently considered by the FAA to be primarily a fire management issue, involving identification of hidden fires. Any future work on this should not result in changes to the standards for interior materials.

The forthcoming NPRM on aircraft cabin interior materials will not contain separate testing procedures for smoke, toxicity and flammability but will consider flammability progression and the threat of flashover as the overriding consideration in determining survival in a post-crash fire. Smoke and gas emissions ensue when burning interior material is the dominant factor in an aircraft fire. The more stringent panel flammability standards to be proposed will result in reduced fire-growth capability, and will delay and reduce smoke and toxicity. The criteria to be used will exclude from use those materials which exhibit early



flashover. The subject of toxicity itself has not been addressed directly. Toxicity testing procedures have not been validated thus far, and no meaningful standards have been developed.

In response to questions concerning the cost-benefit analysis for the cabin interior materials proposal, the FAA indicated that it could not separate the benefits in terms of aircraft hulls and lives saved from the seat fire-blocking and interior materials improvements in relation to the costs involved. It is not possible to predict accurately lives which will be saved, or to equate dollar costs with lives saved. The approach taken has been to demonstrate by full-scale testing that the proposed concept provides increased safety over the existing methods, and that the costs involved are small or reasonable in view of the better performance.

### **Transport Aircraft Crash Dynamics and Occupant Survival**

Several speakers stressed the need for defining seat strength in terms of dynamic criteria based on the energy loading and crash environment, including human impact tolerances, rather than in terms of static "g" loading. Analytical techniques are needed to produce structural and occupant response data which could be validated against test information including the recent Controlled Impact Demonstration (CID) results. It should be possible to predict the dynamic response of the aircraft cabin floor, seat, and occupant in representative crash scenarios. Human impact tolerance criteria can then be established with needed confidence. Considerable work must be accomplished prior to initiating rulemaking.

An industry/FAA subcommittee was established through the Air Transport Association in its four-phase transport aircraft crash survivability program. This industry group disagreed with the FAA plan to issue advisory circulars on human impact tolerance, crash scenarios, analytical modeling techniques, and proposed rules defining dynamic criteria and seat performance based on recognized human tolerances. This disagreement is based on the perceived lack of data needed for the advisory circulars, including crash-load pulse patterns for transport aircraft and human tolerance criteria, as well as the lack of available computational capability needed for some of the analytical modeling techniques proposed. The subcommittee had made a concerted effort to convince the FAA to change the B-720 CID to match the test conditions of the previous L-1649 crash demonstration, so that the results might be directly compared. In particular, 18 fps was suggested instead of the scheduled 20 fps sink rate. In response, the FAA pointed out that the referenced transport aircraft crash survivability program was about 10 years old and was conducted parallel to related general-aviation and rotorcraft programs. Those programs were very successful and, preparation of advisory circular material and regulatory proposals for seats are well under way. The FAA recognizes that the transport aircraft program is a long way from completion and that the forthcoming advisory circulars must be considered only tentative, pending availability of additional data. Some of these data will come from the B-720 CID, which was largely successful from a structural testing standpoint, even though the test conditions were not in accordance with industry subcommittee recommendations. It was agreed, however, that the planned June, 1985 completion date may be unrealistic, but the FAA believes that good progress has been made and that a preliminary draft of a tentative seat standard may be available by that time. The computer capacity limitations for analytical modeling are also recognized, but should not be an insurmountable limitation. Perhaps predictions from element tests might be utilized for demonstration of compliance with certification standards in some cases.

### **On-board Fire Management**

The FAA has no plans for work specifically on burn-through resistance of cabin interior panels, but will evaluate the effectiveness of on-board total flood foam/water sprinkler systems. Performance of the most promising system will be evaluated for a variety of fire intensities, and should be completed by November, 1986. The FAA expressed some concern over the possible toxicity of Halon total flood systems under conditions of inadequate ventilation in occupied compartments. It was pointed out that new centralized computer-controlled fire management systems for aircraft utilizing Halon 1301 have been developed and approved for installation on general aviation and transport category aircraft. This new technology should provide for earlier detection and better containment of on-board compartment fires. It was recommended that the FAA extend its total flood research and testing to include Halon 1301.

## **On-board Equipment**

The usefulness of a fire axe for gaining access to on-board fires was questioned. Instructions and/or caveats for its use are not generally provided to the crew while non-discriminatory use may damage important electrical or hydraulic equipment. It was noted that the fire axe can be used as a pry bar for removal of decorative panels to gain access to hidden fires such as those which have occurred in lavatories. The area of smoke emergence is frequently not at the source of the fire, but the source may be located by feeling for the hottest panels in the suspected area. The axe could be useful at that time.

It was pointed out that available on-board water, if atomized, would be a very effective auxiliary fire extinguishing and cooling agent. This would require relatively little additional effort and expense. The FAA has investigated the use of fire blankets made of fire-blocking materials in its anti-hijacking efforts. It was found that fire-blocked seats with fire-blocking layers can withstand a fire involving about one pint of gasoline but that fire blankets appear to be effective only for small or flat "pan" fires. Any large or three-dimensional fires involving approximately three rows of seats are best handled by an on-board Halon 1211 extinguisher with supplementary water afterwards.

## **Occupant Restraints**

One problem with child restraint seats is that some may block ready access to the aisles by passengers in adjacent seats. Problems of this nature will continue until considerably more experience by the public and the airlines is obtained in dealing with the FAA and NHTSA rules governing these devices. This subject is discussed more extensively in the *Inflight Occupant Protection* section of these proceedings.

## **Compliance Problems**

Airline representatives reported that the number of recent FAA regulatory actions relating to aircraft cabin safety has severely taxed the ability of the airline industry to respond in a timely fashion, e.g., the proposed three-month response time to the forthcoming NPRM on interior materials is insufficient. The two-year time period for compliance with the new floor-proximity lighting standards is not realistic in view of the lack of guidance material for compliance with the new design standards and the time required to accomplish the needed installations on each airplane in the fleet. A suggestion was offered that all of the currently proposed rules be integrated in a single package so that compliance problems and costs may be minimized.

The views of the domestic airlines were repeated by representatives of foreign airlines and manufacturers, which desire to comply with FAA rules and desire to respond to FAA rulemaking proposals.

# EVACUATION AND SURVIVAL WORKSHOP

## SUMMARY OF PROCEEDINGS

Chairman: Hector Barrera; Manager, Flight Attendant Training & Passengers, Frontier Airlines

The Evacuation and Survival Working Group met to discuss factors affecting evacuation and occupant survival in the post-crash environment. Considerable attention was given to the role of passenger education as well as flight attendant training. Other discussions included evacuation-related injuries, new emergency lighting standards, evacuation signal systems and the merits of flotation devices, particularly during inadvertent water landings. Attention was also focused on the FAA's rulemaking activities and procedures. The following is a summary of the discussions.

### Passenger Education

This workshop group was in total agreement that passenger education is a critical area of cabin safety. Three aspects of passenger education were discussed.

- 1.) There is a need to correct passengers' misconceptions regarding evacuation. For example, most passengers overestimate the amount of time they can safely stay in the aircraft when there is an external post-crash fire. Two surveys revealed that passengers thought they had an average of 5 minutes to evacuate the aircraft in an accident with post-crash fire. The responses ranged from 30 seconds to 17 minutes. This could result in passengers waiting too long in their seats before moving towards the exits. Another misconception is that all seat cushions are flotation cushions. (See *Water Survival Section*). In another study, over 50% of the individuals surveyed said they would *not* use oxygen masks, should they be deployed, until an announcement pertaining to their use was made. This is supported by actual decompressions and in experimental studies where people do not react for a considerable period of time. One solution is to have automatic recorded commands. This is an optional item available to air carriers in several languages. Many passengers also have misconceptions about the correct brace position or the best positions to hold infants.
- 2.) Revision of verbal commands which crew members give to passengers is needed. An example given was the command to "GRAB ANKLES", when this is an impossible task for most people due to narrow seat pitch.
- 3.) There is a need to increase information which passengers receive regarding cabin safety. For example, passengers need to know the correct brace positions before takeoff, however, few passengers read the safety card and this information is not covered in the pre-departure briefing. It is also important to educate passengers on how to survive in a cold-water environment including the effects of movement in the water and of hypothermia. A suggestion was made to teach school children about the importance of airline passenger safety could be useful in influencing their parents and would also prepare the children for when they become airline passengers.

The group also discussed the effectiveness of innovative flight attendant safety announcements to stimulate passenger interest. While a flight attendant's announcement may stimulate one passenger's interest in the safety briefing, it may well cause another passenger on the same flight to lose confidence in the cabin crew's dedication to safety. For this reason, innovative safety announcements must be viewed with caution. One carrier's solution to the problem of routine announcements is to standardize announcements but to vary them on a periodic basis. It was suggested that passengers may be more responsive to safety information if they are told the reason why they are being asked to do something. It was further offered that peer pressure can have positive effects, in that, when some passengers begin to obey safety instructions, other passengers follow. The importance of the visual part of the briefing was voiced as a concern in that some passengers cannot see the briefing when there is only one flight attendant in the first class cabin and one flight attendant in the main cabin.

## Training

There was general agreement among the workshop participants that hands-on training is the most effective. The representative of one organization recommended that the FAA require 8 hours minimum flight attendant training to facilitate hands-on training in the classroom for transition and recurrent training. It was further stated that some air carriers have hands on training every 24 months and that this should be changed to every 12 months. Other participants also had a serious concern about the inadequacies of current requirements for hands-on training and suggested a reevaluation of the number of hours required.

The majority of air carriers stress hands-on training; however, the FAA specified number of hours which must be devoted to hands-on training does not take into account individual carrier differences such as fleet size, differences of aircraft, and route structure. The importance of allowing the airlines flexibility in terms of hours and how they structure their training programs, based upon the needs of the particular airline, was stressed. On the related topic of crew training in the area of ditching procedures, there was little consensus. Some participants believe that wet-ditching training is essential for all crewmembers while others believe that current regulations are adequate. A need for further evaluation is indicated.

## Emergency Equipment

One participant pointed out that the designs for improved emergency equipment, standard life vest, single chamber individual flotation devices, and better lighting have been available for years. In many cases they are lighter and less expensive than equipment presently being used.

Regulatory agencies, such as the FAA, specify only performance requirements and this results in a variety of designs. These designs do not always come from the manufacturer, many of them come from the airlines who are responsible for the equipment under product liability law. The airlines are responsible for deciding what kinds of equipment they want to carry and if they want to come to an agreement in order to standardize.

One individual commented that it is not reasonable to expect passengers to be familiar with and be able to operate the many different types of emergency exits and life vests. This individual recommended standardization of emergency equipment. Many of the workshop participants were in agreement.

Non-standardization of location and type of emergency equipment as well as door operation is also a growing problem for flight attendants whose airlines are buying or leasing different make/model airplanes from other airlines. This problem is reflected in alleged poor performance of at least one air carrier's flight attendants at recurrent training. While it is possible to standardize basic training procedures and equipment on a particular aircraft (e.g., B-727 series door and window exit operation) standardization of the type and location of emergency equipment remains an air carrier's internal decision. This is due, in part, to the fact that FAA regulations specify performance requirements but not the particular means of compliance. One individual pointed out that regulations are intended to specify to a minimum level of safety and leave the means of achieving this level to the individual operator. If the FAA were to specify one particular means or design type, then further developments and advances would be hindered. Another individual stressed the importance of the free enterprise system and the fact that each air carrier has its own approach to meeting the requirements of regulations and solving the many safety issues. One participant suggested that airlines and manufacturers make better use of flight attendants as a resource in learning the best location for emergency equipment.

It was brought to the group's attention that the pen flash lights issued by some air carriers to their flight attendants are not adequate. The FAA's Civil Aeromedical Institute has studied the effectiveness of flashlights and has concluded that, beyond a certain light intensity level, brighter is not always better. A proposed Society of Automotive Engineers Aerospace Recommended Procedure No. (SAE ARP) standard for installed portable lighting at flight attendant stations addresses this issue. On the same subject, reference was made to the FAA having recognized the usefulness of flashlights in smoke evacuations.

Concern was expressed regarding the location of flight attendant jumpseats which project into the aisle. These jumpseats could interfere with passenger egress if the flight attendant became incapacitated in the

seat. There was a suggestion that the size of the jumpseats should be modified to accommodate the average male physique since many flight attendants are now male.

## Evacuation

Evacuation-related injuries and clarification of what constitutes a precautionary evacuation were discussed. One individual offered the definition of a precautionary evacuation as an evacuation which occurs anytime the safety of the aircraft is in doubt.

Discussion revealed that air carriers have different policies regarding flight-attendant initiated evacuations. Many participants agreed that the flight attendant is often in the best position to assess damage and/or fire in the cabin. Commencing an evacuation without notifying the cockpit, however, can present evacuation problems if the engines are still running. A suggestion was made that a camera be installed in the tail and a video screen be located in the cockpit and at each flight attendant station to provide crewmembers with capability to access external conditions. The group discussed the importance of supervising passengers on the ground, with the use of a megaphone following an evacuation. One participant expressed concern about the safety of passengers on the ground from rapidly approaching crash fire rescue vehicles. This individual recommended a regulation requiring procedures to ensure the safety of passengers on the ground after an evacuation. Another participant expressed doubt that procedures could be established to cover all possible situations and this individual stressed the importance of flight attendants "using their heads" in any given situation.

On the subject of emergency escape path lighting, it was questioned whether there were any systems that would presently meet the requirements of the new rule. In one individual's opinion, there are several lighting systems that appear quite promising. This individual went on to point out that with the present wording of the rule, it will be very easy for the manufacturers to meet the requirements. This participant then expressed hope that the air carriers would go beyond the minimum requirements specified by the rule. Later in the discussion similar concerns were expressed about the adequacy of the minimum requirement for compliance with the new emergency escape path lighting rule. (See discussion on Regulations)

One commenter stated that placement of lights on the armrests of the seats presumes that the seats will still be attached to the floor fittings. Research on emergency escape path lighting has shown that small, less intense lights which are close together are better than large, bright, strobe type lights. Another researcher found that in most cases, passengers did not follow sequentially flashing lights (SFL) to an exit unless they knew the purpose of the sequence lights. Their tendency was to head toward the door through which they boarded the aircraft. On the other hand, when they were instructed to follow the SFL, nearly everyone followed the directional lights. If an exit is blocked, passengers do not tend to go to another exit without being told beforehand that if the exit could not be opened, to try to find another. This raises some interesting questions regarding educating passengers on the various types of emergency lighting systems likely to be found as a result of the new lighting rule. This individual recommended that manufacturers and operators decide on a standardized emergency escape path lighting system.

Further, on the subject of the new emergency escape path lighting rule, clarification was offered which indicated that the rule was designed to indicate a path towards emergency exits and not to indicate which emergency exits are usable. Passengers will still be dependent upon voice commands for guidance and cabin crew training programs should incorporate such information.

There was a brief discussion of the merits of tactile cues in assisting crewmembers and passengers in locating exits during an evacuation. An obvious disadvantage of tactile cues located along overhead compartments was the fact that an individual would have to stand upright in a possible smoke-filled environment to use the cues. One individual felt that it was too much to expect passengers to use this type of tactile cue in any situation and that counting seat backs to an exit would be the best tactile cue if seats remain in their installed position.

On the subject of evacuation alarms, it was pointed out that in 1971, during the development of the B-747, the SAE developed ARP 1178 on an evacuation signal system which is presently a customer option. The purpose of this system is to indicate that an emergency evacuation is required. At this point the flight attendant then has the responsibility of assessing conditions to see if the escape route is useable. If it is not,

the flight attendant is expected to redirect passengers to a useable exit path. This system, when used properly, could be much more effective on wide-bodied aircraft than voice commands alone since voice commands take longer and can be misinterepreted.

Communication can also be a problem on narrow-bodied aircraft, especially if the engines are still running. Some type of audio warning is necessary to get flight attendants' attention so that they can assess conditions and redirect passengers if necessary. There was discussion of accidents involving aircraft which were not equipped with an alarm system and where the megaphone used in the back of the cabin could not be heard by occupants in the front. One participant raised the question of why flight attendants do not carry whistles to quiet the cabin and get everyone's attention before giving verbal instructions to one another and/or passengers. It was suggested that the FAA require evacuation alarms and establish who should use them. One commenter pointed out that even evacuation alarm systems can cause confusion. This individual emphasized the importance of flight attendants evaluating the nature of the emergency and reacting accordingly. The group concluded that evacuation alarm systems can prove to be effective in promoting successful evacuations; however, further study to determine the actual need for requiring such systems on aircraft is suggested.

The group also suggested that the public address (P.A.) system could be an effective way for flight attendants to communicate with passengers during an emergency landing and evacuation. It would be essential, however, that any information being carried over the P.A. system apply to everyone in the cabin. It was pointed out that the P.A. is not available after power has been shut down and that megaphones are seldom if ever used in unprepared emergencies. Even in prepared emergencies, megaphones are virtually useless because they are often inaccessible or can become projectiles upon impact. It was recommended that the P.A. system be independently powered or connected to the emergency bus. The obtaining of additional data on the viability of independently powered P.A. systems for emergency communication on aircraft was recommended. Many participants believe that shouted human voice commands can be the most effective means of conveying emergency procedures to passengers.

Also discussed was the question of whether to allow passengers to wear their shoes when evacuating down an escape slide. One researcher estimated that half of the airlines require passengers to take their shoes off and half do not. Four or five years ago the puncture strength of slides was improved. Slide manufacturers would prefer to have passengers keep their shoes on with the exception of ladies' high heels. The hazards of wearing crepe soled shoes on an evacuation slide was pointed out. When the crepe soles come into contact with the slide, serious injury can result from the braking action. The review of the TSO-C69 on evacuation slides for the purpose of possible inclusion of requirements for the physical properties of slide surfaces for newly manufactured slides should be considered.

## **Flotation Devices**

Flotation platforms are being developed and are currently defined as a "non-redundant air holding flotation device." They can be a single chamber device such as an evacuation slide. A flotation platform does not have to be an auxillary piece of equipment or even necessarily a new piece of equipment. On narrow-bodied aircraft, door mounted evacuation slides with quick-release girt bar and perhaps hand-hold straps could become the primary piece of flotation equipment. These flotation platforms would be simpler, lighter, and more accessible than current overwater equipment. One individual pointed out that life rafts stowed in overhead compartments are not practical because they are heavy and not readily accessible.

In a study involving U.S. airline passengers, three-fourths of the subjects believed that all seat-bottom cushions are flotation devices. This perception may have implications for U.S. air carriers relating to the following: passenger education; the installing of life vests in lieu of flotation cushions; and the functional utility of flotation cushions as individual flotation devices especially in the cold water environment.

On the subject of water survival, it was held by several workshop participants that current regulations regarding overwater equipment and the equipment specified in those regulations do not address the unplanned water landing in the significant bodies of water in the immediate areas of many U.S. airports. There are 216 airports in the U.S. adjacent to significant bodies of water. It is felt by these individuals that operations over significant bodies of water should be protected with both individual and mass flotation

devices. Mass flotation, under this concept, could be provided or at least augmented by door mounted evacuation slides which are configured with a quick disconnect feature as mentioned earlier. A representative from a non-U.S. air carrier said that their flight attendants are trained to use all single slides as flotation platforms.

One commenter suggested that since most accidents occur during takeoff or landing, water rescue equipment should be placed at the airport. Water rescue platforms exist at some airports such as Boston's Logan Airport and Washington's National Airport, according to this individual.

Another individual suggested that passengers carry their own life vests. This individual, as well as several of his friends carry an FAA-approved single cell life vest weighing 3-5 lbs. Another suggested possibility is to ask passengers to pay a few cents more for each airline ticket for safety improvements such as standardized life vests.

Regarding operation of the life vest, it was suggested that life vests should not be inflated before the passengers step out of the plane; otherwise, the passenger will rise with the water in the cabin. One individual suggested designing a floatable seat cushion with a strap that would wrap around the person and attach them to the cushion.

## **Rulemaking**

There was some discussion about whether or not regulations are intended to regulate to a minimum level of safety. One individual disagreed with the statement that regulations are minimum requirements, but rather regulations should be thought of as a compromise between people who don't want anything and people who want everything. A government representative present responded that this may be the subjective view of some individuals but, in practice, and objectively, regulation is by definition a minimum requirement.

Concern was expressed about the FAA's method of approving equipment or determining compliance with a given regulation. For example, FAA personnel responsible for approving new lighting systems under the new emergency escape lighting rule, may or may not seek additional guidance information before approving the system. An air carrier or airframe manufacturer could meet the requirement and show compliance with nothing more than properly designed flood lights at the exits which shine into the aisle. From a safety standpoint this is not adequate, yet, depending upon how the system will be evaluated, it may meet the minimum requirement. The need to consider crash scenario criteria rather than simple operational demonstrations in approving equipment and system designs was emphasized.

On the subject of improved emergency equipment, it was suggested that efforts should be directed towards improved performance standards in the TSOs. Standards need to be better defined; that is, goals and objectives of standards need to be spelled out. In many cases there are two criteria in conflict that must be balanced. For example, the donning criteria for life vests to make them easy to get on may not make them as effective in the water. Compromises involved in balancing the criteria must be considered. All newly designed equipment needs to be properly tested to ensure that the manufacturer is meeting the needs of the user. Much of the responsibility for the difference in the types of equipment being used lies with the air carriers. The demand of the public for improved safety equipment may be the incentive needed for the air carriers to make improvements in safety.

On the subject of comments in response to Notices of Proposed Rulemaking (NPRM), it was alleged that all NPRM comments may not be given equal weight. Important input from technical or user sources very often seems to be omitted from final rulemaking. This is a matter of great concern to the group.

## **Flight/Cabin Communication**

The group agreed that flight/cabin communication is critical. One suggested from the group called for those air carriers which have cockpit resource management programs to include flight/cabin communication in the training curriculum, recognizing the flight attendant as a safety resource. It was further suggested that all carriers consider implementing cockpit resource management programs.

Although discussion on this subject was very limited in this particular workshop, FSF believes it is of considerable importance, and therefore, it is given more extensive treatment in the combined analysis section of these proceedings.

# COMBINED ANALYSIS OF WORKSHOP DISCUSSIONS

## Passenger Education

Passenger safety information/education has long been a subject of interest, discussion and controversy within the aviation community. There is agreement, however, that a primary factor in assuring the rapid and safe evacuation of passengers from an airplane is the adequate transfer of passenger safety information. Information gathered in many accident investigations reveals that the present system for educating passengers regarding airplane safety features has failed to achieve its full potential of increasing survivability. For example, precious seconds can be wasted when passengers are uncertain which exit to use. Furthermore, if passengers are unaware of how to open an exit, they can hinder the escape of others.

Inadequate passenger safety information is also a problem during inflight emergencies such as a decompression. Many passengers are reluctant to use the oxygen mask without an inflight announcement directing them to do so.

Research indicates that instructions given at the time of a decompression can significantly increase the percentage of people who respond quickly and correctly. Flight attendants would not be able to help each individual passenger at the time of a decompression. Therefore, instructions should be given automatically over the public address system, or as printed instructions available to the passenger when a decompression occurs, such as a placard attached to the inside of the oxygen compartment door. A disadvantage of the placard approach, however, is that the placard could be obscured in low-level lighting at night or by the temporary fog that often accompanies a decompression. Another is the potential for excited passengers not reading instructions. Vision is more susceptible to hypoxia than is hearing and there is also a potential language problem, given the international composition of today's passenger group.

Another problem encountered during decompressions is the passengers' reluctance to pull the mask hard enough (it requires about 1-4 pounds pull force) to get the oxygen flowing. On some aircraft, pulling one mask will start the oxygen flowing to the other masks in the compartment. On other aircraft, each mask must be pulled to activate the oxygen flowing to the mask. To ensure that passengers use the amount of force necessary to activate the flow of oxygen, the pre-departure instructions on the operation of the emergency oxygen mask should be changed from "pull the mask towards you . . ." to "pull firmly" or "pull sharply" on the mask. Some airlines' cabin safety briefings are very explicit on this procedure.

Some passengers are not sure if the oxygen is flowing. Since oxygen is odorless, tasteless and colorless, it is difficult to detect. Furthermore, at 14,000 feet cabin pressure altitude, oxygen flows through the mask at between 0.5 and 1.0 liter per minute. At this rate, it may be difficult to feel oxygen flow on the face. Also, the reservoir bag probably will not expand at a low rate of oxygen flow even though there is an adequate supply of oxygen. Many people expect the gas bag attached to the oxygen mask to expand and contract with each breath. Some airlines point this fact out to their passengers during the safety briefings.

There are presently two types of oxygen-flow indicators in use. In one design, the oxygen supply tube leads into a small area of the reservoir bag which fills with oxygen before more oxygen flows into the larger section of the bag. This small area is colored green and has the words, "Green Inflated-Oxygen O.K." printed on it. The other type of indicator is built into the oxygen-supply tube which leads into the reservoir bag. This indicator is normally opaque white but when the oxygen is flowing, a small green inner cylinder becomes visible through a transparent section. The fact that in the majority of cabin safety briefings, passengers are not informed of the location and operation of these oxygen-flow indicators, once again indicates a lack of uniform high standards of passenger education.

The effective performance time (EPT), also known as the time of useful consciousness (TUC), is the period of time from onset of a decompression to the inability to perform a purposeful act. At 40,000 feet the TUC is only about fifteen seconds. Therefore, the speed with which a passenger puts on any oxygen mask is important. Even though the flight attendants demonstrate the use of the oxygen masks prior to each flight operating above 15,000 feet, there have been many instances where passengers have been unable to use the oxygen masks correctly in actual decompressions.

Recognizing that approximately 84% of major (hull loss) accidents occur during one of the phases



associated with take-off or landing, passenger education for these phases should be emphasized. Knowing the proper brace positions can significantly increase a passenger's chances of surviving impact forces. Air Carrier Operations Bulletin 1-76-23 "Brace for Impact Positions" was revised November 18, 1982 to reflect the most desirable brace positions for adults, children, pregnant or handicapped passengers, and flight attendants. One way to make this information available to passengers is to include it in a safety page in the airlines' inflight magazine. Other important safety information could also be included such as emphasizing the importance of evacuating an aircraft quickly and how to increase one's chance of survival in a cold water environment, including the adverse affects of excessive movement in the water. Through the creative use of illustrations, including cartoons, supplemented by brief written instruction, the educational possibilities are substantial.

Research on the effectiveness of the pre-departure briefing announcement has revealed that novelty is one of the key factors in capturing attention. For instance, one airline asks that . . . "you check to make sure your fellow passenger's seat belt is fastened." However, it was pointed out in the workshop that, while a flight attendant's announcement may stimulate one passenger's interest in the safety briefing, it may cause another passenger on the same flight to lose confidence. One air carriers solution to the problem of routine announcements is to standardize several announcements but vary them on a periodic basis. This approach warrants consideration for use by other air carriers. Workshop discussion also revealed that passengers are more responsive to the safety announcement if they are told "why" they are being asked to do something. This approach has merit and should be given careful consideration by air carriers.

Another idea would be the use of presentations at the departure gate, possibly with the use of passenger volunteers. These presentations could be of any type such as video, personal briefing, static display, etc.

Many airlines are using video presentations of safety information with good effect. For those aircraft equipped with video tape systems, consideration should be given to capturing passenger attention by using special sound effects, background music to generate excitement, interesting characters, illustrations and computer-generated graphics, and situational drama. Airlines should also test the information depicted on their safety briefing cards to ensure that it is being interpreted clearly and correctly.

There is a need for clarification of some of the verbal commands given by crewmembers during an emergency. For example, airlines should consider alternative commands such as "HEADS DOWN" instead of "GRAB ANKLES" which is physically impossible for many passengers in present aircraft configurations of high density seating. Evacuation commands should be positive, for example, "RELEASE SEATBELTS", instead of, "UNFASTEN SEATBELTS", because some passengers may not hear the "UN".

In July of 1983, the NTSB recommended that "the FAA convene a government/industry group to study the problem of passenger education and suggest improvements." In his remarks to this Cabin Safety Conference NTSB Chairman James E. Burnett stated that, "the FAA has been partially responsive in that it has indicated it will have a consulting group look at the issue in the general context of cabin safety."

## **Supplemental Oxygen**

Federal Aviation Regulation (FAR) 25.1447 requires that if a large airplane is certificated for an altitude exceeding 30,000 feet, the total number of oxygen dispensing units and outlets must exceed the number of seats by 10 percent. The extra units must also be uniformly distributed throughout the cabin as practicable.

Since the oxygen units are enclosed, there is no way of determining the location of the additional required units. It is common practice for major aircraft manufacturers, however, to install an additional mask at each grouping of seats. This eliminates the problem of identifying the location of the additional masks as long as the information is contained in the flight attendant and customer service publications.

Air carriers operating aircraft that are not equipped with an additional mask at each seat grouping should provide a means of identifying the location of the additional oxygen masks such as placarding. This information is essential to the flight attendant who may have a need to use a supplemental mask in the event of a decompression. Customer service representatives also need this information to ensure that adults traveling with infants who will not be occupying a seat, but will instead be sitting on their parents' lap, are assigned to a seat grouping that is equipped with an additional oxygen mask.

The Flight Safety Foundation recommends that the FAA's Principal Operations Inspectors (POI) review their air carrier's procedures to ensure that the flight attendant and customer service publications specify the location of additional oxygen masks and emphasize the importance of having ready access to these masks.

## Carry-on Baggage

Excessive or improperly stowed carry-on baggage can present a number of safety hazards to aircraft occupants. The most serious problem associated with carry-on baggage is that it can become dislodged in a crash and strike occupants or block access to exits. Excessive carry-on baggage may also make it impossible to reach emergency equipment stowed in overhead compartments or closets and it can block access to life vests under passenger seats. Carry-on baggage can also serve as a source of fuel that can contribute to the severity of inflight or post-crash fires. Finally, valuable seconds can be lost in an emergency evacuation as passengers attempt to gather personal belongings before leaving the aircraft.

Injuries from carry-on baggage can also occur in turbulence or a hard landing when overhead baggage compartments open and occupants are struck by unrestrained carry-on items. FAR's require that the overhead baggage compartments be placarded for the maximum weight of their contents; however, there is no assurance that the articles placed in the overhead compartments will not exceed the maximum authorized weight.

Despite the potential hazards of carry-on baggage, passengers prefer and in many cases, air carriers do not discourage passengers from, carrying their baggage on board the aircraft. For passengers, there is the obvious advantage of not having to wait for checked baggage at the end of the flight. In an increasingly competitive market, some airlines have embarked on advertising campaigns to promote larger and more accessible carry-on baggage compartments. From an airline economic standpoint, it may be beneficial to have passengers carry their baggage on board the airplane, since it reduces the number of baggage handlers required and provides more belly cargo space. Finally, the screening of carry-on baggage by airline personnel at the gate is a time-consuming task that could result in delayed departures unless additional personnel are utilized.

During the FAA Operations Review Program of 1975, the Association of Flight Attendants urged that FAR 121.589 be amended to require that carry-on baggage be screened prior to boarding. The intent of the proposal was supported by representatives of the Transport Workers Union (TWU), National Transportation Safety Board (NTSB), and Flight Engineers International Association (FEIA). At that time, the existing regulations specified simply that an aircraft could not take off or land unless each article of baggage was properly stowed. A. A commented on that regulation as follows:

JUSTIFICATION: Carry-on luggage has continued to dislodge and hamper exiting of aircraft in accidents; therefore, the amount and size of carry-on should be scrutinized and restricted prior to passenger boarding. Historically, flight attendants have been expected to monitor carry-on luggage; however, pre-boarding as well as boarding duties do not allow for proper surveillance and often necessitates unnecessary delays to rectify the problems. Surveillance and restriction of carry-on items should be accomplished prior to passenger boarding and should not be the sole responsibility of the flight attendants . . .

As a result of this proposal, the FAA issued a Notice of Proposed Rulemaking on May 11, 1978 (43 Fed. Reg. 20448) providing that:

121.589 (a) No certificate holder may allow the boarding of carry-on baggage on an aircraft unless the baggage can be stowed in accordance with this section. No certificate holder may allow an aircraft to takeoff or land unless each article of baggage carried aboard the aircraft is stowed . . .

In the preamble to this proposal, the FAA stated that:

During hard crash landings, carry-on baggage has become dislodged from stowage areas, inflicting injuries to passengers and hampering the emergency evacuation of aircraft. The FAA believes that all carry-on baggage should be screened before being allowed aboard the aircraft to prevent

loading of baggage which cannot be properly stowed.

FAR 121.589 was revised June 19, 1980 giving the certificate holder specific authority to prevent the boarding of carry-on baggage which cannot be properly stowed in a suitable closet or baggage stowage compartment. However, in the five years since enactment of this rule, in many instances oversized large carry-on baggage is still being brought on board and the space available for stowage is often being exceeded.

A special DOT/FAA National Air Transportation Inspection (NATI) team was formed to conduct a study of problems existing in Part 121 air carrier operations. Our discussion will be limited to their findings in the area of carry-on baggage.

In May of 1984, three FAA inspectors visited 10 selected airports, and conducted 198 inspections on 37 air carriers. In addition, 21 unannounced enroute observations and 17 regular enroute inspections were conducted. The findings of the NATI team were as follows:

- Odd size items and excess carry-on baggage are often stowed in the lavatories, cockpit, or empty seat rows due to the lack of space or adequate size facilities.
- Flight attendants frequently discover items during taxi that cannot be properly stowed due to the size or shape.
- Passengers frequently board with very large or odd shaped items that will not fit in an authorized stowage area.
- The number and size of garment bags (hang-up suitcases) take up so much space that it is difficult to store all items carried on board.
- Carry-on items stored under seats frequently leave insufficient leg room to facilitate rapid egress from that row.
- Flight attendants must spend considerable time during taxi-out relocating and stowing carry-on baggage instead of attending to other safety duties and requirements.
- Flight attendants expressed general confusion over FAR 121.285(c) concerning proper stowage of cargo in the passenger compartment.
- The weight of carry-on items frequently exceeds the weight limitations of stowage bins and closets.
- Excessive garment bags stowed in hang-up areas often bulge and partially block the main exit aisle.
- Hang-up closets are frequently not placarded or have only one placard not specifying if it applies to the rod or to the floor limits.
- Numerous flight crews have expressed serious concern about weight and balance limitations due to the amount of carry-on baggage.

In light of the foregoing problems caused by excessive carry-on baggage, the NATI team recommended that FAR 121.589 be amended to include the following requirements:

- a) Maximum limit of two carry-on items per passenger, excluding women's purses.
- b) Maximum weight of 15 pounds for each carry-on item.
- c) Each item carried on board must be of such a size so as to fit completely under a seat or in a designated carry-on baggage stowage area.
- d) An aircraft cannot be moved until each item of carry-on baggage has been properly stowed and the cabin is secure.

The NATI report went on to note that "it is important that regulatory changes limiting carry-on baggage be widely disseminated to the traveling public."

On August 23, 1984, the Association of Flight Attendants (AFA) petitioned the FAA for rules requiring airlines to measure and limit carry-on baggage prior to boarding. The proposal establishes means to ensure that carry-on baggage is, in fact, screened prior to boarding as required in existing regulations.

AFA proposes that "carry-on baggage would have to be measured and, taken together, would have to fit within a space of 9" x 16" x 20". However, if it were obvious that the baggage would fit within these dimensions, it would not have to be measured. If an airline could demonstrate to the agency that it has additional space available on its aircraft, then the airline could, in addition, measure and allow garment bags with a width of less than 3" aboard the aircraft." This proposed system for screening carry-on baggage is similar to a voluntary system successfully being used in Canada.

In support of their position, the AFA surveyed flight attendant safety representatives representing 21,000 flight attendants from 14 air carriers on the subject of carry-on baggage. The survey revealed that the total volume of carry-on baggage frequently exceeds the available space. The secondary and related problem is that individual items being brought on board are too large.

This raises the question of the need for screening carry-on baggage on the basis of weight as recommended in the NATI report. Similarly, it is necessary to establish a maximum limit of two carry-on items per passenger, excluding women's purses (as proposed in the NATI report) as long as, when measured together, the size allowance is not exceeded.

The Flight Safety Foundation recommends that the FAA require airlines to measure and limit carry-on baggage. Rulemaking of this nature would ensure that carry-on baggage is screened in accordance with existing regulations governing carry-on baggage and would eliminate existing hazards due to excess carry-on baggage on board aircraft.

### **Child Restraint Systems**

The FAA has issued an advisory circular (AC 91-62; 2/26/85) indicating that all models of child restraints are acceptable for use on aircraft, as long as they contain the Federal Motor Vehicle Safety Standard (FMVSS) No. 213 label. The FAA and the National Highway Traffic Safety Administration (NHTSA) recently revised FMVSS No. 213 to include the criteria of TSO-C100 so that certification to the new FMVSS No. 213 by the manufacturers would result in seats approved for use in aircraft as well as automobiles. The revised FMVSS No. 213 became effective February 26, 1985. The FAA has terminated TSO-C100 and now accepts new FMVSS No. 213 as the sole specification necessary for child restraints to be approved for aircraft.

It is anticipated that an increasing number of parents will wish to use these seats for restraining their children on board aircraft. Parents have become more aware of restraint systems in the many states which require children to be restrained in automobiles. All approved child restraint seats should be permanently marked to indicate they are certified for use on aircraft. All child restraint seats should also be inspected for serviceability before being allowed on the aircraft.

### **Food and Beverage Carts**

Food and beverage carts have been a source of injuries for both passengers and cabin crews in turbulent conditions. The major problems stem from failure or inability to secure the cart when turbulence is encountered. In many cases, once turbulence is encountered the flight attendant is unable to manage the unsecured cart. Due to improper or inadequate repair and maintenance, some carts cannot be secured under any conditions. This situation appears to arise from a breakdown in reporting a need for cart maintenance to the appropriate department in the air carrier company. This problem is further complicated since these carts are moved from one aircraft to another, thus the maintenance write-up may stay with the aircraft while the cart is taken off, restocked and put aboard another aircraft.

Design standards for food and beverage carts are inadequate. Some designs reportedly have contributed to medical problems for flight attendants such as back injuries, foot injuries, and "carpel tunnel syndrome" which is an injury to the wrist caused by frequent hand brake use on some carts.

Injury incidents from food and beverage carts should be reduced as a result of a revision to Air Carrier Operations Bulletin issued 1-76-19 July 2, 1984. This Operations Bulletin discusses flight and cabin crewmember coordination and communication, and safety during potentially hazardous conditions of



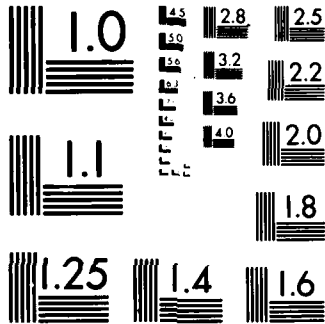

MICROCOPY RESOLUTION TEST CHART  
NATIONAL BUREAU OF STANDARDS-1963-A

flight. The Bulletin instructs principal operations inspectors to review their assigned operator's training program and operational manuals to ensure that the operator has established a safe and effective means of coordination and communication between the flight and cabin crewmembers. Some of the procedures to be addressed include:

Guidance to flight crewmembers on the importance of a predeparture briefing of the senior flight attendant to include anticipated turbulence conditions, scheduling of cabin services, clean-up, securing of galley and cabin, carry-on baggage, and passengers.

Use of the public address system to alert flight attendants and passengers of anticipated turbulence.

Guidance for notifying flight attendants when they are to cease inflight services, secure galley, be seated with their restraint fastened or to resume duties.

The FAA should continue to ensure strict adherence to these procedures. The FAA should also encourage air carriers to develop improved communications between their departments to assure proper maintenance of food and beverage carts. Flight Safety Foundation recommends that the SAE S-9 Committee consider this problem area and develop appropriate standards for food and beverage carts that identify good operator and passenger safety design principles. As a source of data for committee guidance, such systems as the ASRS, for example, might be employed to obtain everyday accounts of problems.

## **Inflight Fires**

Air carriers are required to report inflight fires" to the National Transportation Safety Board (NTSB) and to the FAA in accordance with FAR Part 121.703, yet, in spite of this requirement, there are inconsistencies in the number of such occurrences reported by the NTSB and the air carriers. The FAA data base consists of all of the inflight fire reports received by the NTSB in addition to reports from their mechanical reliability reports. The discrepancy in the number of inflight fires in the NTSB, FAA, and air carrier data bases may be due to differing interpretations of the severity of the fire. All major inflight fires are included in each reporting system. However, a fire which is perceived to be insignificant, such as a lighted cigarette on a passenger seat which is quickly extinguished by a flight attendant, may be entered into the air carrier's data base and not reported to the NTSB or the FAA.

## **Passenger Protective Breathing Devices**

The FAA has completed a staff study to reevaluate the appropriateness of the various types of protective breathing devices being proposed to protect passengers from smoke and toxic fumes in an inflight and post-crash fire. The study concludes that there are no devices presently on the market which protect the passengers without serious shortcomings.

Civil Aeromedical Institute (CAMI) research has shown that the use of smoke hoods can increase evacuation time significantly when used in a post-crash fire. However, when used for inflight fires, these devices, to be effective and useful, must have self-contained air or oxygen supplies, or the aircraft oxygen system must be significantly redesigned to provide oxygen to these devices. Since smoke hoods cannot function as breathing devices in the event of a sudden decompression, they must be supplemented by the present oxygen system.

Another proposed device which attaches to the individual passenger air outlets has the drawback that many aircraft are equipped to provide only recirculating cabin air to these outlets. Some outlets (as those located above the center seats in the Lockheed L-1011 airplane) are not reachable due to their location in the high ceiling, and more importantly, many airplanes are being manufactured without these individual-style outlets.

Another protective breathing device features a rebreather bag which attaches directly to the present decompression oxygen mask. Testing by the FAA showed some promise for this device, although significant changes to the airplane oxygen system would be necessary to accommodate the 100 percent oxygen demands at all altitudes for approximately 20 minutes. Recent tests by the FAA also indicate problems with the mask-to-face sealing at high cabin altitudes.

It was suggested that breathing through wet hand-towels might be the best available means of passenger protection from smoke and toxic fumes. There is, however, mixed evidence regarding the effectiveness of using wet towels as a survival measure. This is due in part to the differing susceptibilities of various irritant and lethal gases to filtering by wet fabric. In the Air Canada inflight fire aboard a DC-9, 15 to 20 wet towels were handed out and used by the passengers. Only three of these passengers survived, but the exact combination of factors involved is not fully understood. Wet cloths have been reported as effective in hotel fires. Currently, the best protection for aircraft occupants in the event of an uncontrolled inflight fire is to land as soon as possible and evacuate the aircraft. Additional protection may be provided to passengers if they cover their nose and mouth with any available cloth and breathe air that is closer to the cabin floor.

Research into methods to purge the airplane of smoke and toxic fumes while in flight appears to show more promise for solving this problem than individual passenger protective breathing devices. The Flight Safety Foundation supports the FAA's decision to complete the needed research on the best method of removing smoke from the airplanes during inflight fires in order to improve inflight survivability and to reduce the likelihood of flashover once on the ground when the doors are opened. New designs and design standards for passenger protective breathing devices should, however, continue to be evaluated by the FAA.

### **Crew Protective Breathing Devices**

Crewmember protective breathing equipment is an essential consideration in the event of an inflight fire. On June 27, 1983, the FAA issued TSO-C99 which established criteria for the protective breathing equipment for air transport flight crewmembers. This TSO is based on an SAE Aerospace Standard, developed from research at CAMI. The new standard requires a full-face oxygen mask or a combination smoke goggles and oxygen mask with positive purging of the smoke goggles to preclude fogging or the buildup of irritant gases that might impair vision.

The FAA has also completed action on an NPRM to improve the protective breathing equipment for all crewmembers operating under Part 121 of the FAR. The proposal would require that all protective breathing equipment for flight deck crew meet, within a 1-year time period, the otherwise optional standards of TSO-C99. It would also provide for equivalent portable protective breathing equipment for flight attendants to assist in fighting fires and would require "hands on" training for all crewmembers in fighting typical aircraft fires. Up to 2 years is being proposed to allow for air carriers to train all of their crewmembers.

### **Flammability and Toxicity of Interior Materials**

On October 26, 1984, the FAA published new standards which will significantly reduce the flammability of present-day foam seat cushions. The standards contain new laboratory test and acceptance criteria that were developed as a result of extensive industry and NASA research and full-scale testing at the FAA Technical Center.

Cushion materials that meet the new standard will significantly reduce the spread of inflight fires. In addition, according to the FAA, "Full-scale testing has shown that aircraft seat cushions designed to meet these criteria delay the onset of ignition within the cabin and reduce the spread of flame and products of combustion, such that at least 40 seconds in post-crash evacuation and survival time can be gained through the use of these cushions." The rule requires that all seat cushions on existing airplanes that were certificated after 1958, comply with the new standards within 3 years.

The FAA is also in the final stages of completing a proposal for improved flammability standards for transport airplane cabin interiors. The criteria focuses on the reduction of both material flammability and smoke and toxic by-products. The new interior wall and bulkhead materials that meet this proposed standard, when combined with similarly improved seat materials, should greatly reduce the spread of fire within the airplane cabin for both post-crash and inflight fires.



## Fire & Smoke Detection

On March 26, 1985, the FAA issued standards for air carrier airplanes which would require each lavatory be equipped with a smoke detector system, that each lavatory trash receptacle be equipped with an automatic fire extinguisher, and an increased number of portable fire extinguishers, at least two of which must contain Halon 1211 as the extinguishing agent. The compliance date for this final rule is February 29, 1986.

Another FAA activity, in the area of inflight fire safety, involves proposed standards to improve fire safety in Class D cargo and baggage compartments by upgrading the fire test criteria for the Class D compartment ceiling and wall liners and by limiting the total size of Class D compartments to 1,000 cubic feet. The FAA plans final action on the proposals by early 1986.

The Flight Safety Foundation supports these rulemaking activities as a material outgrowth of research and development carried out by government and industry laboratories in Europe, Canada and the U.S., as examined and recommended by the Special Aviation Fire and Explosion Reduction (SAFER) in its report of 1980.

## Crash and Fire Protection

Workshop participants generally avoided discussion of technical details of the forthcoming NPRM on improved standards for transport aircraft cabin interior materials, but instead concentrated on procedural aspects and expected problems of compliance with the proposed rule. The proposed standards for improved interior materials would delay flashover and would reduce the rate of fire spread within the cabin. Due to the far-reaching implications of the proposed rules, the three month response time may be insufficient. The time period required for compliance after eventual adoption of the regulation on improved transport aircraft cabin interior materials has not yet been determined by the FAA.

The final rule on floor proximity emergency lighting requires a two-year compliance time by all transport aircraft certificated after January 1, 1958, and operating under FAR Part 121. (See section on *Emergency Evacuation*) The new rule on seat cushion fire-blocking layers requires that all seat cushions on existing airplane types certificated after January 1, 1958, and operating under FAR Part 121 comply with the new standards within three years. (See section on *Inflight Fires*)

Although the Air Transport Association and the Aerospace Industries Association participants expressed the opinion that the FAA four-phase transport aircraft crash survivability program is premature, the Flight Safety Foundation believes that enough preliminary information exists to proceed in this area. It is agreed that this is a complex area, however basic improvements can be initiated to be further refined as more information becomes available from the analysis of the Controlled Impact Demonstration (CID) data and other sources.

Work which was accomplished by the General Aviation Safety Panel (GASP) in the area of improving crash protection in small aircraft should be reviewed by the FAA for techniques which may be applicable to transport category aircraft.

The FAA has no plans for additional research or testing on burn-through resistance of cabin interior materials, though industry effort is continuing. It will, however, investigate on-board total flood (foam-water sprinkler) fire-management systems for system and cost effectiveness over a range of fire intensities. Because Halon 1301 total flood systems can cause toxicity problems in poorly ventilated enclosures, FAA will first study Halon concentrations in small unpressurized aircraft. The development of centralized, computer-controlled, on-board fire management systems using Halon 1301 may offer significant benefits in on-board fire management capability, especially if extinguishment agent concentrations can be controlled to avoid toxicity problems. The Flight Safety Foundation encourages FAA to continue its work with Halon systems to look for improved fire management with acceptable toxicity levels.

## Emergency Evacuation

The FAA has a number of evacuation-related safety requirements such as inflatable evacuation slides, minimum aisle width, maximum number of seats abreast to reach the aisle, minimum intensity levels of emergency lighting, and the size, brightness, and location of exit locators. These evacuation-related requirements appear to be effective in preventing serious injuries. While serious injuries are relatively rare, minor injuries such as cuts, bruises, and sprains are common.

Evacuation-related injuries are more difficult to assess in an accident involving significant impact. Accident reports frequently fail to specify if an injury was sustained from the original impact or from the subsequent evacuation. Smoke and/or fire create the most difficult conditions for evacuation. Smoke tends to concentrate most heavily in the upper third of the cabin and can be dense enough to obliterate the general emergency lighting and the emergency exit signs while conditions in the lower part of the cabin remain visible and survivable. A tragic example of the loss of visual reference due to smoke occurred in an inflight fire aboard a DC-9 on June 2, 1983. Two male passengers who had been seated forward of the overwing exits at landing, were found dead in the aisle well aft of those overwing exits.

## Emergency Egress Indicators

On October 26, 1984 the FAA issued a final rule on Floor Proximity Emergency Escape Path Markings. The regulations will require all aircraft certificated after 1958, as Part 121 air carriers, to be equipped with an emergency evacuation guidance system designed to enable each passenger to visually identify the emergency escape path along the aisle of the cabin, and to readily identify each exit from the emergency escape path by reference only to visual features not more than 4 feet above the floor.

In response to this new FAA regulation, the Evacuation Research Unit at CAMI is undertaking a program to study new and/or significantly improved lighting systems. Early tests indicate that small light sources spaced close together are more effective than a few very bright sources spaced further apart. Extremely bright sources of illumination may simply illuminate the smoke without improving the general visibility of the cabin. Lighting systems should also be kept simple to avoid the confusion and ambiguity which can result from sequential lighting or high intensity strobe lighting. In addition to the traditional incandescent and fluorescent lamp systems, CAMI will be studying systems based on light emitting diodes and the new high intensity electroluminescent lamps. Early demonstrations of tritium markers raise serious questions regarding the ability of this system to adequately meet the objectives and intent of the new FAA regulation.

## Emergency Communication to Passengers

Evacuation signal systems, which are presently a customer option, can be useful in communicating the need to evacuate, particularly on wide-bodied aircraft where voice commands can be misinterpreted or not heard. If used improperly, however, they can cause confusion. Communication can also be a problem during the evacuation of a narrow-bodied aircraft, especially if the engines are still running. The voice commands of a flight attendant may not be heard, even with the use of a megaphone. Other disadvantages of megaphones include their inaccessibility and their potential for becoming projectiles upon impact. The FAA should give careful consideration to the benefits of aural warning devices/systems, including examining the merits of a suggestion from a workshop participant that flight attendants use a "police-type" whistle to quiet the cabin and get the passengers attention before giving verbal instructions. Prior to establishing any requirements, however, further study is needed to determine the effectiveness of warning devices/systems onboard aircraft.

The public address (P.A.) system is another way flight attendants can communicate with passengers during an emergency landing and evacuation. A disadvantage of using the P.A. system for this purpose is that any information conveyed must apply to all of the passengers. Additionally, P.A. systems are often difficult to hear, even under normal operating conditions.

The FAA currently requires the P.A. system to operate independently of the aircraft intercom system. It is usually one of the last systems to fail. The P.A. system is not operative, however, when the main aircraft power has been interrupted or engine power has been shut down. Loss of P.A. power can have serious implications for providing passengers with the necessary preimpact instructions and, in some cases, for initiating and directing emergency evacuations.

An NPRM to require power to be supplied to the P.A. system from a power source independent of the main electrical generating system was removed from consideration by the FAA in August 1982. Although a number of commenters supported adoption of the proposed rule, the FAA determined "that the cost of compliance with such a rule would outweigh any identifiable safety benefits. However, implementing this proposal for new aircraft designs will be considered in the future." This position was iterated in August 1984 in testimony before a Congressional subcommittee hearing on aircraft cabin safety. During this hearing, the F.A.A. Administrator stated that "the FAA will consider requiring that public address systems be powered by an independent power source on new aircraft designs." The Flight Safety Foundation supports this FAA position, feeling that it merits prompt attention.

### **Escape Slide Damage**

There is considerable difference of opinion regarding the advantages/disadvantages of wearing shoes during an emergency evacuation. In the past, the heels of shoes posed a threat to the integrity of slides, at times puncturing or tearing them and causing them to fail. In recent years, the tear strength of slide materials has been improved and the threat of damage from shoes has been greatly diminished (except in the case of high-heeled shoes). Yet, approximately half of the air carriers still include instructions for the removal of passengers' shoes in their procedures for preparation for evacuation.

Guidance information is needed to reflect the current FAA position that men's and ladies' low heeled shoes should be worn during an evacuation in order to protect the passenger from possible injury from post-crash fire, debris, and other hazards likely to be found on the ground at the crash site. Wearing crepe soled shoes, however, can impede the evacuation and can result in serious injury because of the high friction between the crepe sole and the evacuation slide. The Technical Standard Order (TSO-C69a) on evacuation slides should be reviewed for possible inclusion of requirements for the physical properties of slide surfaces for newly manufactured slides.

There has been a great deal of controversy surrounding the recent FAA approval to remove the overwing floor-level exits 3L and 3R on the Boeing 747-100 and -200 series airplanes with a seating capacity of less than 440 passengers.

The Boeing 747 was originally certificated with 10 exits and a maximum seating capacity of 550 passengers. Some foreign air carriers operating with less than 440 passengers have already modified their aircraft and approximately a dozen airlines have received modification kits from Boeing. The FAA has made a determination that two doors can be removed for every 110 passengers taken off the plane. However, this decision is being reviewed. Removing the exits will allow extra space to rearrange seating or to add galleys. Removal of the two doors, including their emergency slides reduces manufacturing costs and also reduces aircraft weight, which saves on fuel costs.

The Flight Safety Foundation shares the conference participant's concerns regarding the FAA approval to remove the exits for the following reasons: 1.) there is no precedent for the removal of Type A exits; 2.) Removing the exits from the overwing area of the B-747 creates a distance of 72 feet between the exits located forward and aft of the overwing area; 3.) the removal of these exits is in direct conflict with the specifications of FAR Part 25.807c which requires that passenger emergency exits must be distributed as uniformly as practicable taking into account passenger distribution; 4.) removal of these exits is not consistent with the FAA Act of 1958 which requires that full consideration by the FAA be given to the duty resting upon air carriers to perform their services with the highest possible degree of safety when prescribing standards, rules, and regulations; 5.) analysis of accidents and incidents involving emergency evacuation reveals that emergency exits are often rendered inoperable due to impact damage or mechanical failure and that exits may be unusable in the presence of external and cabin fires.

Based on the potential for egress problems in the event of an accident, Flight Safety Foundation cannot endorse FAA's action in approving the removal of 3L and 3R exit doors from the B-747-100 or -200 series airplanes with a seating capacity of less than 440 passengers.

## Flight/Cabin Crew Communication

Two recent accidents highlight the importance of effective flight/cabin crew communication as a vital ingredient in flight safety. In May 1983, an L-1011 carrying 172 persons was about to ditch in the Atlantic off the coast of Florida because oil leakage triggered the loss of all three engines. The senior flight attendant was correctly told by the flight engineer to "prepare the cabin for ditching". The next announcement from the flight crew came over the public address system, saying that the ditching was "imminent." As a result, the flight attendants instructed the passengers to assume the brace position. The aircraft was still about 10,000 ft. over the ocean and descending at 1,600 feet per minute which meant that the flight attendants could have had several minutes to prepare the cabin for ditching.

In a formal report on the L-1011 accident, the NTSB noted that the "9 or 10 minutes passengers spent in the brace position was excessive and caused problems with the passengers." The report also concluded that the absence of information from the flight deck during this period "made it difficult for the flight attendants to prepare for ditching."

As a result of its investigation, the NTSB recommended that the FAA require air carriers to revise their flight manual emergency landing/ditching checklist in the emergency procedures section and their flight deck crew duties checklist in the ditching/landing procedures section to:

- "make them consistent with those procedures in the flight attendant manual regarding the cockpit crew informing the flight attendants of the nature of the emergency and the approximate time available for cabin preparation . . .
- "prescribe a standardized signal (from the flight deck) to flight attendants to direct passengers to assume the brace position."

The NTSB also proposed that FAA air carrier operations inspectors be required to review the flight manuals, flight attendant manuals and training programs of their assigned air carriers to assure the adequacy of the emergency procedures and checklists.

The FAA issued an Air Carrier Operations Bulletin 1-76-19 entitled, "Flight and Cabin Crewmember Coordination and Communication Safety During Potentially Hazardous Conditions of Flight" on July 2, 1984. The bulletin requires FAA principal operations inspectors to review their operators' training programs and operational manuals to assure that a safe and effective means of communication and coordination is established between flight and cabin crew members. (See section on *Turbulence*)

In its report on the June 2, 1983, DC-9 inflight fire and subsequent emergency landing, the NTSB expressed concern about "the crew's underestimation of the severity of the fire" and "conflicting information on the progress of the fire provided to the captain by the crew." The NTSB report questioned the delay in the captain's decision to initiate an emergency descent and landing after being informed of the lavatory fire. The board said it "believes the first delay to allow the first officer to assess the situation may have been reasonable" but added:

" . . . the second delay (between the first officer's first and second visit to the lavatory area), based on optimistic reports concerning the condition of an unseen fire, contributed to the severity of the accident."

The total elapsed time, from the time the flight attendant reported the fire to the cockpit until a decision was made to land, was six minutes and 45 seconds. The report said that, "if the captain had made a decision to descend immediately after the first inspection, the aircraft could have been landed at Louisville Ky.

three-to-five minutes earlier than its arrival at Cincinnati. The earlier landing, in turn, would have decreased the time passengers were exposed to the toxic environment in the cabin and would have enhanced their chances of survival."

The FAA Air Carrier Operations Bulletin 1-76-19 revised on July 2, 1984 and referred to earlier in this section, is a positive step toward assuring that safety information in flight deck and cabin crew manuals is consistent and contains information on the duties and responsibilities of the entire crew. Flight deck and cabin crew communication could also be enhanced through flight deck personnel training on leadership techniques and resource management. Ninety-five percent of the flight crews' aircraft is located behind the cockpit door and the trained cabin crew members are resources available to the Captain.

## **Handicapped Passengers**

There are approximately 40 million U.S. citizens who are disabled. These individuals provide a unique challenge to the aviation industry to ensure their safety and comfort in air travel as well as the safety of others on board. The FAA issued Advisory Circular (AC) 120-32 on "Air Transportation of Handicapped Persons" on March 25, 1977, to identify the problems faced by handicapped air travelers and to provide guidelines to airline personnel to help alleviate these problems.

This AC defines a handicapped person as a person who may need the assistance of another person to expeditiously move to an exit in the event of an emergency. These people have a disability or a condition that could lead to a significant delay during an emergency evacuation of an aircraft or could increase the risk of that person being injured during the evacuation.

Handicapped passengers are further categorized as:

**Ambulatory** - A person who is able to board and deplane from the aircraft unassisted and who is able to move about the aircraft unassisted. This includes the blind, deaf, mentally retarded, etc.

**Nonambulatory** - A person who is not able to board and deplane from an aircraft unassisted or who is not able to move about the aircraft unassisted.

The FAA requires that a flight attendant brief a handicapped passenger before each take-off on where, when, and how to evacuate the airplane in the event of an emergency. More specifically, the flight attendant will brief the handicapped passengers and their personal attendant, if any, on the routes to each appropriate exit and on the most appropriate time to begin moving to an exit in the event of an emergency. During this pre-flight briefing, the flight attendant will also inquire of the handicapped passengers and/or their attendant as to the appropriate manner of assisting the person in order to prevent pain and further injury.

The FAA's Civil Aeromedical Institute (CAMI) has conducted extensive research to determine where handicapped passengers should be seated in anticipation of an emergency evacuation. In a report entitled "Emergency Escape of Handicapped Air Travelers," (FAA-AM-77-11) researchers revealed that handicapped passengers seated in window seats used nearly 50% of their total evacuation time moving from window seat to aisle. The AC recommends that handicapped passengers be seated in areas in which evacuation would normally occur through a floor-level, non-overwing exit.

CAMI also conducted tests to determine the feasibility and safety of permitting blind persons to keep their travel canes at their seats during takeoff and landing. Based upon this research and comments received on the FAA's NPRM, the FAA determined that the stowage of canes under passenger seats is acceptable provided that the cane is placed flat on the floor and does not protrude into an aisle or exit row.

There are obvious advantages for blind passengers to have ready access to their travel canes inflight and in deplaning the aircraft in normal conditions. However, in the event of an actual emergency evacuation, FAA studies reveal that canes were found to be associated with delays in evacuations through floor level

exits more often than when no canes were present. Attempts to rely on canes for guidance during an evacuation rather than to rely on fellow passengers for assistance, will be more likely to delay the blind passenger as well as able-bodied passengers. In a true emergency, with the presence of life-threatening smoke and fire, passengers may not be tolerant of such a delay and, in their rush to leave the aircraft, may injure the blind passenger who is using a cane.

Using escape slides will be difficult in any event, but the potential for damage to a slide or injury to passengers using the slide is increased if canes are in use. The problems of puncturing a slide with a cane are similar to those which exist with high heeled shoes, but are compounded by canes which fracture and can produce puncture wounds. If a cane is inadvertently placed so that it blocks the exit, it may be strong enough to resist breaking and thus delay the evacuation.

To complement the efforts of the airlines to provide safe and adequate service to handicapped passengers, Flight Safety Foundation recommends that the FAA should make a concerted effort to educate the handicapped on aviation safety issues that affect them, as part of overall passenger education efforts as previously discussed. In addition, a presentation could be made to each of the organizations for the handicapped which could then inform their constituents.

## **Flotation Devices**

Current FAA regulations regarding overwater equipment do not address the unplanned water landing in the significant bodies of water in the immediate areas of many U.S. airports. It is estimated that nearly 70% of U.S. commercial airline arrivals or departures occur over significant bodies of water. This amounts to approximately 7 million takeoffs or landings over water each year. Using statistics for the twenty year period from 1959 to 1979, the FAA's recent "Water Survival Staff Study" revealed that 27.6% of all jet accidents occurred in the takeoff, or climbout phase, and 54.5% occurred in the approach or landing phase. Add to these statistics the fact that airport area rescue facilities are unable to adequately respond to aircraft water accidents in time to save even able-bodied survivors in cold water environments. The FAA "Water Survival Staff Study" makes several recommendations:

- 1) Augment regulations requiring seat fire blocking to include flotation capability.
- 2) Encourage industry to continue development of flotation platform standards. Consider requests to substitute such devices for rafts when their technology is sufficiently developed.
- 3) Develop advisory guidance to airport operators in the areas of rapid response procedures and specialized rescue equipment.
- 4) Require operators to include crew training for inadvertant ditchings.
- 5) Develop criteria for assuring 15 second life vest donning compliance.
- 6) Continue research on modified flotation cushions and other individual flotation devices.
- 7) Emphasize water accident hazards to pilots during training and checkrides.
- 8) Examine current life vest storage methods to determine if vest access problems exist; take action as necessary.
- 9) Examine feasibility to allow quick disconnect on narrow-body aircraft evacuation slides, so that they may be used for flotation devices.

The Flight Safety Foundation supports the FAA's efforts to identify overwater safety initiatives that focus on the threat of an inadvertent water landing, and endorses the recommendations identified in the FAA "Water Survival Staff Study".

## Flight Attendant Training

Current Federal Aviation Regulations on flight attendant emergency training require 16 hours of instruction during initial training. The required subjects include the duties and responsibilities of the flight attendant, appropriate FAR's, emergency training, the authority of the pilot in command, passenger handling and a knowledge of each airplane type as it pertains to the flight attendant's duties. Twelve hours of recurrent training is required annually. However, the FAA frequently grants exemptions to the twelve-hour requirement resulting in the average length of recurrent training being between 6-10 hours. Emergency drills and instruction in emergency equipment are required once every 24 months.

The training methods utilized by air carriers (both U.S. and non-U.S.) vary considerably. For example, U.S. air carriers' training for evacuation from a smoke-filled cabin ranges from filling simulated cabin with a smoke substance and requiring the flight attendants to maneuver through the aisle to reach the emergency exits and locate missing passengers, to this question; "What would you do in a post-crash fire?"

Flight attendant training has been the subject of testimony at Congressional hearings and has been the subject of many NTSB recommendations. In numerous accident reports, the NTSB has cited poor training as contributing to flight attendant errors.

The benefits of hands-on training are well recognized in the aviation industry. However, as mentioned earlier, there are considerable differences among the airlines in the number of hours devoted to hands-on training and the types of hands-on training (i.e. fire fighting and wet ditching) offered during initial, transition, and recurrent training. The FAA also recognizes the benefits of hands-on training in its recent NPRM to require improved hands-on training for flight attendants in fighting typical aircraft fires.

Improved hands-on training is also needed in the operation of doors, ditching, and in first-aid. Other training improvements which should be considered are: combined emergency training for flight and cabin crews; emphasizing their respective duties and the importance of teamwork; and providing realistic information on what is expected in a post crash environment including the role of the fire department, medical teams, police, and other support groups.

Some air carriers provide the level of training described above while others do not. The Flight Safety Foundation endorses consideration of standardization of flight attendant training as a means of upgrading those training programs which fall short of the safety standard necessary to ensure competent and professionally trained flight attendants.

## First-Aid Training

Federal Aviation Regulations (FARs) require that "crewmember emergency training must provide for the proper use of first-aid equipment and the handling of emergencies involving illness, injury or other abnormal situations involving passengers or crewmembers." When a medical emergency occurs, the flight attendant makes a primary assessment and initiates appropriate action. The "immediate action" procedure for assisting an unconscious passenger, as outlined in the training manuals of most major air carriers, is to administer cardiopulmonary resuscitation (CPR).

U.S. carriers differ greatly in the scope of emergency medical training given flight attendants. A 1980 survey of 27 U.S. air carriers revealed that the number of hours devoted to first-aid training ranged from 4.5 hours to 28 hours in initial training. In the recurrent training program instruction in first-aid varied from 1/2 hour to 8 hours.

The survey also revealed considerable variation among the air carriers in CPR training. The amount of instruction ranged from no instruction to 15 hours of instruction in initial training. In the recurrent training program, instruction ranged from no instruction to 4 hours.

An FAA special report, "Air Carrier Cabin Safety - A Survey," December 1976 contained the following recommendation: "Office of Aviation Medicine, in coordination with the Flight Standards Service, develop guidance for air carriers on the scope and extent of first-aid training for flight attendants." The special report was developed following consultation with flight attendants, industry representatives and FAA

aeromedical and safety personnel. Flight attendants interviewed during the survey were desirous of becoming better informed and skilled so that they could handle inflight injuries and incapacitation of passengers or crew in a competent manner. The recommendation was also reviewed at the Flight Standards/Medical Research Committee meeting at the Civil Aeromedical Institute (CAMI), May 10-11, 1979, and received Committee support.

The airlines are not required to report inflight medical emergencies to the FAA unless the incident results in a fatality. However, one major air carrier provides passenger illness and injury statistics to the FAA on a voluntary basis. A summary of this air carrier's reported incidents for a 12-month period in 1979 reveals 44 incidents of passenger unconsciousness, 5 of which resulted in death.

Over 40 million Americans have some major form of heart and blood vessel disease resulting in over one million heart attacks each year. Add to this figure the elderly, debilitated, chronically ill persons and the fact that U.S. scheduled air carriers now account for more than 80% of all passenger-miles of intercity transportation, and the potential for inflight emergencies exists on virtually every scheduled air carrier flight.

The average length of service of U.S. flight attendants has increased from approximately 2 years in the 1950's to the present average seniority of 11 years. Given the career duration of today's flight attendants, the present 2 percent attrition rate, and the greater number and variety of passengers flying today, the likelihood of a flight attendant being confronted with a heart attack victim aboard an airplane is much more possible.

When asked about improving first-aid training or providing emergency medical equipment, airline managers often argue that an unscheduled landing is the best course of action. In many cases this may be true; however, unscheduled landings can take an hour or more. Widebody aircraft have an especially limited choice of emergency landing sites due to runway, taxi-way, and ramp limitations and all aircraft may have air traffic limitations or diversions during periods of adverse weather.

*Immediate emergency care, including first-aid and CPR should be available aboard the airplane to ensure the highest possible levels of occupant safety. Flight attendants trained to deal with inflight medical emergencies may be able to stabilize the victim. In some cases, this on-board capability may even allow continuation of the flight to the scheduled destination, obviating the need for a diverted landing and the accompanying inconveniences, fuel waste and other increased costs.*

CPR training for crewmembers for inflight medical emergencies raises questions about how this procedure can best be administered in the confines of an aircraft, how movement of the victim can be accomplished efficiently while the procedure is underway, and the best place in various types of aircraft to ultimately place the victim (e.g. out of the way of the aisle, the galley and emergency exits). Some simple and effective inflight techniques for administering CPR are described in an article entitled "Emergency Medicine and the Airline Passenger", *Aviation, Space, and Environmental Medicine*, September 1980.

Should first-aid and CPR training be extended to flightdeck crewmembers? A factor for consideration is that many freighter flights have no flight attendants onboard but do carry certain passengers such as couriers. Pilot incapacitation is another consideration. A study conducted by the International Civil Aviation Organization (ICAO) revealed that during a 7 year period, there were 17 instances of pilot deaths in the cockpit. Of these 17 deaths, 5 led to fatal accidents causing 148 fatalities. Of these 5, 4 deaths occurred during the approach phase of flight. It was also found that two-thirds of the 17 pilots who died were under the age of 50.

The potential for litigation in the U.S. has discouraged many professionals from volunteering their help in medical emergencies for fear of being sued by the victim or relatives for errors in judgment or treatment.

On January 3, 1985 Senator Barry Goldwater introduced Bill S-63, "Inflight Medical Emergencies Act" in the Senate of the U.S. This bill would encourage the rendering of inflight emergency care by requiring the placement of emergency first-aid medical supplies and equipment aboard aircraft and by relieving appropriate persons of liability for the provision and use of such equipment and supplies.



Careful consideration should be given to establishing an Office of Aviation Medicine recommended first-aid/medical training program to include thorough training in CPR. This suggested minimum training standard, along with current medical techniques in dealing with inflight medical emergencies, is presently being developed by the FAA in an Advisory Circular. Another alternative could involve developing a Notice of Proposed Rule Making (NPRM) concerning the standardization of airline basic first-aid and recurrent training programs.

## **Emergency Medical Equipment**

On March 3, 1981 the Aviation Consumer Action Project (ACAP) petitioned the FAA to require the carriage of emergency medical equipment on commercial flights. A large majority of commenters expressed support of the proposal indicating that U.S. air carriers should be required to have emergency medical equipment and medication on board their airplanes that would enable crewmembers and/or medically qualified passengers to respond to any inflight medical emergency. Opposing commenters expressed concern about the potential added cost to the traveler, malpractice accusations, pilferage of medicines and equipment, and the possible use of medical equipment and/or medication by unqualified individuals.

The FAA analyzed the comments and concluded that the FAA did not have the authority to require air carriers to provide equipment and medicine to handle general health emergencies unrelated to flight or not shown to affect aviation safety. A Denial of Petition was issued to ACAP on May 19, 1982. The petitioners requested the United States Court of Appeals for the District of Columbia Circuit to review the issue of whether the FAA lacks statutory authority to institute rulemaking to upgrade the quality of first-aid kits currently carried on board commercial aircraft. The court held that the FAA has the statutory authority to proceed with rulemaking on the subject if it deems that such action is advisable based upon merit.

As a result of the court's decision, the FAA has again reviewed the ACAP petition and comments received in response to its publication in the Federal Register. The majority of physicians who commented on the ACAP petition agree that the first-aid kits now required on aircraft by Part 121 of the Federal Aviation Regulations are inadequate for purposes of diagnosing and treating most inflight medical emergencies. These physicians strongly recommend that diagnostic equipment be provided on all flights as well as equipment and medication that may be used for the treatment of medical emergencies that may be expected to occur.

Upon reconsideration, on March 14, 1985 the FAA issued an NPRM to require one medical kit on each passenger-carrying flight. The kit should contain equipment and drugs required to provide basic life support during medical emergencies that might occur during flight, such as myocardial infarction, severe allergic reactions, acute asthma, insulin shock, protracted seizures, and childbirth.

The NPRM would also require each certificate holder to maintain records on each medical emergency occurring during flight resulting in use of the required emergency medical kit, diversion of the aircraft, or death of a passenger or crewmember. In making this proposal, the FAA recognizes that complex issues remain regarding who would be considered qualified to use the proposed kits, the user's licensing requirements, and whether or not the kits should be required on all flights or limited to flights of long duration where diversion to a surface facility is not possible. The FAA has invited public comment on these issues.

## **Flight Attendant Flight and Duty Time Regulations**

The FAA was considering flight attendant flight and duty time rules as early as 1962. In testimony before the House Subcommittee on Transportation and Aeronautics of the Interstate and Foreign Commerce Committee, the FAA explained that:

They (the flight attendants) have a residual responsibility for passenger safety, and, in several perilous situations, their contributions have been heroic. Many passengers owe their lives to the courage and calm skill with which flight attendants have carried out their duties in times of crisis.

(Testimony of George Prill, Director, FAA Flight Standards Service, May 1, 1962).

A survey of 33 flight attendant safety representatives in 1971, indicated that the longest scheduled duty days averaged 12-14 hours, although four representatives reported duty days over 17 hours. They stated that the maximum number of takeoffs and landings averaged between six and ten, although four representatives reported over 20 takeoffs and landings on a given day.

A 1974 FAA "Listening Session with Flight Attendants" resulted in a report which stated that:

The need was recognized, however, for a fuller and better coverage of flight attendants under the Federal Aviation Regulations. A number of cases were cited that demonstrated the need very graphically. Several instances were mentioned that involved flight attendants working 16 and 18 hours or more, without rest or relief, and without even a chance to eat. This obviously was detrimental in many ways; from the FAA's viewpoint of flight safety, such practices are particularly dangerous.

(FAA' Listening Session with Flight Attendants, October 17, 1974, p. 10)

In 1975, the FAA held its First Biennial Operations Review. In response to a proposal submitted by the Association of Flight Attendants (AFA) on flight time and duty time limits for flight attendants, the FAA proposed six specific recommendations followed by an evaluation and justification. The six recommendations are as follows:

- 1) An air carrier or commercial operator may schedule a flight attendant to fly in an airplane for eight hours or less during any 24 consecutive hours without a rest during those eight hours.
- 2) Each flight attendant who has flown more than eight hours during any 24 consecutive hours must be given at least 16 hours of rest before being assigned to any duty with the air carrier or commercial operator.
- 3) Each air carrier and commercial operator shall relieve each flight attendant from all duty for at least 24 consecutive hours at least once during any seven days.
- 4) No flight attendant may fly as a required flight attendant more than 120 hours during any 30 consecutive days.
- 5) No flight attendant may fly more than 1200 hours during any calendar year with an air carrier or commercial operator.
- 6) No flight attendant may be on duty for more than 16 hours during any 24 consecutive hours.

Action on these proposals was deferred pending the resolution of an ongoing pilot duty time proceeding. Ten years later, the FAA is faced with a petition for rulemaking from AFA for flight attendant flight and duty time regulations equivalent to those applying to the pilots.

The basis of the AFA petition is that through the FAA regulation of pilot flight and duty time, the FAA has acknowledged that:

- 1) Inadequate rest degrades performance.
- 2) Reduced performance of safety duties has a negative effect on the safety of passengers.
- 3) The contractual flight and duty time rules negotiated by some, but not all carriers, do not provide adequate assurance that crewmembers will have adequate rest.

In their petition for rulemaking, AFA contends that these principles apply equally to flight attendants and that "flight attendants perform important safety functions, which, if similarly degraded, will jeopardize passenger safety." The petition points out that "flight attendants must take with them to any flight a great store of knowledge which they have obtained through training and experience, and must have this information ready for their use." For example, flight attendants must know the location and use of emergency equipment; they must know the evacuation procedures for land and water crashes; they must also have the knowledge to deal with other emergencies including decompressions, inflight fires, hijackings, turbulence, inflight medical emergencies, etc. As stated in the AFA petition, "All of this detailed knowledge may not be easily recalled, much less acted upon, if the flight attendant is excessively fatigued."

These arguments form the basis of the AFA's proposal that flight attendants should be guaranteed the same amount of rest as the pilots. The Flight Safety Foundation shares the safety concerns outlined in the AFA petition for rulemaking on flight attendant flight and duty time regulations. Flight attendants do perform important safety functions that could be compromised by fatigue. It is recommended that the FAA respond favorably to this petition for rulemaking.

## **Rulemaking**

Coordination and cooperation between all facets of industry and the FAA is essential prior to formal action on proposed rulemaking. Industry considers this action to be crucial since their perception is that conclusions on many of the issues will likely have been formulated by the time an NPRM is issued, making substantive changes to the proposed regulations difficult if not impossible. An Advanced Notice of Proposed Rulemaking (ANPRM) is one useful means for involving interested parties in the early stages of the rulemaking process.

Continuing coordination and contact among technical personnel is also essential to ensure that the interests of all affected parties are considered. In many cases it appears as if all comments in response to proposed rules may not be given adequate consideration. For example, for the ten proposals that were withdrawn from the Operations Review Program; Amendment No. 11 regulatory package (published in the Federal Register August 2, 1982), seven of the proposals had "several commenters" or "a number of commenters" support the proposed rule and in each case only one commenter "objected" or "opposed" the proposal. Additionally, pertinent input from technical or user sources is often not reflected in final rulemaking.

The FAA's method of approving equipment or determining compliance with a given regulation should involve realistic operational demonstrations. For example, under the new floor proximity emergency lighting rule, an air carrier or airframe manufacturer could presumably meet the requirement with nothing more than properly designed flood lights at the exits that shine into the aisle. From a safety standpoint this is not adequate and it does not meet FSF interpretation of the intent of the rule. FAA personnel responsible for approving equipment or determining compliance should be provided with guidance information to ensure consistent interpretation.

Performance standards for emergency equipment need to be better defined. The goals and objectives of Technical Standard Orders (TSO) should be clearly stated. In many cases there are two criteria in conflict that must be balanced. For example, the donning criteria for life vests which makes them easy to get on may make them less effective in the water and vice versa. Compromises involved in balancing the criteria must be carefully considered.

In future rulemaking, the FAA should consider, where feasible, integrating related proposed rules in a single package to minimize compliance problems and costs.

## **Reference For Cabin Safety Publications**

A vast amount of information has been published on the subject of cabin safety. The FAA recently published a Cabin Safety Subject Index (FAA-AM-84-1) to promote awareness of FAA documents pertaining to cabin safety.

There remains a wealth of information on a variety of cabin safety subjects, however, that have not been identified or indexed to date. To facilitate easy access to this information, the FAA should publish a document containing an index of all cabin safety publications along with a brief description of each publication.

## COMMENTS AND RECOMMENDATIONS

1. FSF agrees with the NTSB recommendation of July 1983, to FAA with regard to efforts in passenger education. These efforts should encompass those aspects described in the *Combined Analysis Section* of these proceedings.
2. The FAA should require that their operations inspectors review their assigned air carriers' procedures to ensure that flight attendant and customer service publications specify the location of additional oxygen masks and emphasize the importance of having ready access to these masks. Air carriers operating aircraft which are not equipped with an additional mask at *each* seat grouping should provide a means of identifying the location of the additional oxygen masks, such as placarding.
3. The Foundation recommends that the FAA consider the AFA pending petition for rulemaking to require airlines to measure and limit carry-on baggage. Rulemaking of this nature would ensure that carry-on baggage is screened in accordance with existing regulations governing carry-on baggage and would eliminate existing hazards due to excess carry-on baggage on board aircraft.
4. All approved child restraint seats should be permanently marked to indicate they are certified for use on aircraft. All child restraint seats should also be inspected for servcability before being allowed on the aircraft.
5. The FAA should encourage air carriers to develop improved communications between their departments to assure proper maintenance of food and beverage carts. Standards for food and beverage carts should be developed by the SAE S-9 committee and problems encountered with food and beverage carts should be reported to a safety reporting system such as the Aviation Safety Reporting System (ASRS) or the Aviation Safety Analysis System (ASAS).
6. Procedures for reporting inflight fires should be reviewed and revised to assure that the desired information is being collected and that there are no discrepancies in these records within FAA, NTSB and the operators.
7. In future rulemaking, the FAA should consider, where feasible, integrating into a single package, concurrently proposed rules in an attempt to minimize compliance problems and costs.
8. The FAA should proceed in its effort to develop dynamic crash criteria, and should review the work done by the General Aviation Safety Panel (GASP) in this area.
9. The FAA should give prompt attention to the requiring of an independent power source for aircraft public address systems on new aircraft designs.
10. The FAA should disallow further removal of floor level exits from aircraft as was recently approved on some Boeing 747-100 and -200 series aircraft with a seating capacity of less than 440 passengers.
11. The FAA should make a concerted effort to further educate handicapped persons on cabin safety items, possibly by making presentations to each of the organizations for the handicapped.
12. The FSF endorses the findings of the FAA Water Survival Staff Study and recommends prompt adoption.
13. Consideration by the FAA should be given to establishing a recommended first-aid/medical training program to include thorough training in CPR.
14. All air carriers should provide cockpit resource management training and should expand that training to include flight/cabin communication techniques.
15. Standardization of flight attendant training should be accomplished, to the extent possible, as a means of upgrading those training programs which fall short of the safety standard necessary to ensure competent and professionally trained flight attendants.

16. The FAA should respond favorably to the pending petition for rulemaking for flight attendant flight and duty time.
17. The FAA should utilize the Advanced Notice of Proposed Rulemaking method, where possible, for inter-related safety proposals.
18. FAA personnel responsible for approving equipment or determining compliance should be provided with detailed guidance information to ensure consistent interpretation to achieve the design performance standard.
19. Research and development of a method to purge the airplane of smoke and toxic fumes while in flight appears to show more promise of a solution than individual passenger protective breathing devices. The Foundation supports the FAA's decision to complete the needed research on the best method of removing smoke from airplanes during inflight fires in order to improve inflight survivability and to reduce the possibility of flashover once on the ground when the doors are opened. New designs and design standards for passenger protective breathing devices should, however, continue to be evaluated by the FAA.
20. The Flight Safety Foundation encourages the FAA to continue its work with Halon flooding systems in an effort to improve fire management with acceptable toxicity levels.
21. The FAA should prepare a document listing all pertinent cabin safety studies along with a brief description of each publication.

**FLIGHT SAFETY FOUNDATION CONFERENCE AND WORKSHOP ON CABIN SAFETY  
REGISTERED ATTENDEES**

Fayseh Aboudi  
Chief Stewardess  
Alia Royal Jordanian Airlines  
CIO Alia, P.O. Box 302  
Queen Alia Airport, Inflight Service  
Amman, Jordan  
08-53111

Bengt Angfors  
Engineer  
Swedish Board of Civil Aviation  
S-601 79  
Norrkoping, Sweden S-601 79  
01146-11192063

Bryan Ashley  
Aviation Safety Inspector  
(Operations)  
FAA, ACDO Chicago  
2300 E. Devon Ave.  
Des Plaines, IL 60018  
(FTS) 251-3945

Barbara Atherton  
Assistant, Manager  
F/A Standards & Training  
Western Airlines  
6060 Avion Drive  
Los Angeles, CA 90045  
(213) 216-4100

Kay Avery  
Administrator Flight Service  
Emergency Procedures and  
Training  
American Airlines  
Learning Center  
P.O. Box 619618-MD.925  
Dallas-Fort Worth, TX 75261  
(817) 355-4114

Julia M. Baer  
End Use Manager  
Celanese Corp.  
P.O. Box 32414  
Charlotte, NC 28232  
(704) 554-3551

E. Alan Baird  
Manager, F/A Training  
Northwest Airlines, Inc.  
Minneapolis-St. Paul International  
Airport  
St. Paul, MN 55111  
(612) 726-2290

V.W. Ballenger  
Director, Engineering and  
Maintenance  
Air Transport Association  
1709 New York Ave., NW  
Washington, DC 20006  
(202) 626-4035

Walter Barr  
Systems Engineer  
Transamerica Airlines  
P.O. Box 2504  
International Airport, Oakland  
Oakland, CA 94614  
(4125) 577-6014

J.N. Barrack  
Senior Project Engineer  
Trans World Airlines, Inc.  
P.O. Box 20126  
KCI Airport  
Kansas City, MO 64195-0126  
(816) 891-4605

Hector Barrera  
Manager, Flight Attendant Training  
& Procedures  
Frontier Airlines  
8520 Smith Rd./DEN-DA  
Denver, CO 80207  
(303) 398-5291

Sharon Barthelmess  
President  
Free to Fly, Inc.  
1000 Connecticut Ave., N.W.  
Suite 1200  
Washington, DC 20036  
(202) 296-0947

Edward Bollinger  
Manager, Commercial Research  
BF Goodrich Co.  
9921 Brecksville Road  
Brecksville, OH 44141  
(216) 367-5220

Cicero Borborena  
Safety Instructor  
Varig Brazilian Airlines Training  
Center  
429 Pasteur Avenue, 5th Floor  
Urca-Rio DeJaneiro, Brasil

Edmond Boullay  
Aeronautical Engineer  
Armament Attache Office — French  
Embassy  
4101 Reservoir Road  
Washington, DC 20007-2172  
(202) 944-6444

Henri P. Branting  
Aerospace Engineer  
Federal Aviation Administration  
800 Independence Ave., S.W.  
Washington, DC 20591  
(202) 426-8382

James Brenneman  
Fire Protection Engineer  
United Air Lines MOC  
San Francisco International Airport  
San Francisco, CA 94128  
(415) 876-5539

Jack Broadbent  
Pilot  
Fairways Corp.  
National Airport  
Washington, DC 20001  
(703) 892-4070

Roger Brooks  
Accident Survival Committee  
ALPA  
12566 E. Bates Circle  
Aurora, CO 80014  
(303) 750-5985

Mary Jo Basso  
Customer Service Manager  
Peoples Express  
Neward International Airport  
Newark, NJ 07114  
(201) 961-8799

John Beams  
President  
Safety Training Systems, Inc.  
5151 South 110th East Avenue  
Tulsa, OK 74146  
(918) 665-0125

Harold Becker  
Manager, Safety Programs Division  
FAA-ASF-300  
800 Independence Ave., S.W.  
Washington, DC 20591  
(202) 426-9472

Milton I. Bickle  
Director, Aviation Services  
American Can Company  
Hangar E, Westchester County  
Airport  
White Plains, NY 10604  
(914) 946-8070

Vahe Vilezikjian  
Group Engineer-Structures  
Weber Aircraft  
2820 Ontario Street  
Burbank, CA 91343  
(818) 848-5543

William W. Bingham  
Manager, Structures Research  
The Boeing Commercial Airplane  
Company  
P.O. Box 3707, M.S. 73-03  
Seattle, WA 98124  
(206) 237-8888

A.C. Bisson  
Deputy Chief Inspector  
Britannia Airways Limited  
Luton Airport  
Luton Bedfordshire,  
England LU2 9ND  
(0582) 424-55

Paul Basista  
Fulltime Representative  
Independent Federation of Flight  
Attendants  
530 3rd Ave.  
New York, NY 10017  
(718) 632-8406

Richard K. Brown  
Associate Executive Director  
Institute of Safety & Systems  
Management  
University of Southern California  
ISSM, Room 104  
University Park  
Los Angeles, CA 90089-0021  
(213) 743-6523

Secor Browne  
Chairman, Board of Directors  
Flight Safety Foundation  
5510 Columbia Pike  
Arlington, VA 22204-3194  
(703) 820-2777

Cecil Brownlow  
Editor  
Flight Safety Foundation, inc.  
5510 Columbia Pike  
Arlington, VA 22204-3194  
(703) 820-2777

Marcia G. Bryars  
Manager, Inflight Training &  
Procedures  
Pacific Southwest Airlines  
9850 Carroll Canton Road  
San Diego, CA 92133  
(619) 586-6714

Joseph L. Buckley  
Assistant Manager Research  
Factory Mutual Research  
1151 Boston Providence Turnpike  
Norwood, MA 02062  
(617) 762-4300

Lee Buell  
Captain  
MCI Communications  
Corporation  
P.O. Box 17440  
Dulles International Airport  
Washington, DC 20041

Isabel A. Burgess, Honorable  
Consultant  
ALPA  
2500 Virginia Ave., NW  
Washington, DC 20037  
(202) 337-3130

Edward J. Burnett, Honorable  
Market Development Manager  
Tex. Tech Industries, Inc.  
20 Daisy Lane  
Orchard Park, NY 14127  
(716) 662-4911

Jim Burnett  
Chairman  
National Transportation Safety  
Board  
800 Independence Ave., S.W.  
Washington, DC 20594  
(202) 382-6500

Elizabeth Ann Burns  
Flight Attendant Safety Instructor  
Saudi Arabian Airlines  
Post Box 167  
Cost Center 959  
JEDDAH — K.S.A  
686-4328 JEDDAH

Edward J. Buxton  
Senior Airworthiness Engineer  
Lockheed  
P.O. Box 551  
Burbank, CA 91520  
(818) 847-5758

Vera Carneiro  
Chief Stewardess — Tap-Air  
Portugal  
National Union Flight Attendants  
Pc Pasteur, 11-R/C DTO  
Lisbon, Portugal  
888774-808191

Betsy Carroll  
First Officer  
Peoples Express  
North Terminal  
Newark International Airport  
Newark, NJ 07114  
(201) 961-8790

Betty Cassella  
Flight Attendant  
People Express  
North Terminal  
Newark International Airport  
Newark, NJ 07114  
(201) 961-8790

Susan Hitt Chambers  
Flight Assistant  
United Technologies Corp.  
400 Main St.  
East Hartford, CT 06108  
(203) 565-2131

Harrison Chandler  
Washington Representative  
Toyad Corp.  
6902 Maple Ave.  
Chevy Chase, MD 20815  
(301) 652-2860

Richard F. Chandler  
Supervisor  
Protection & Survival Laboratory  
CAMI/MMAC  
P.O. Box 25082  
Oklahoma City, OK 73125  
(405) 686-4851

Ross Cheit  
University of California, Berkeley  
2670 Hearst Avenue  
Berkeley, CA 94708  
(415) 642-4670

Collin Church  
Interagency Liaison  
U.S. Consumer Product Safety  
Commission  
CPSC, Rm 700  
Washington, DC 20207

Rick Clarke  
Vice President  
Events Analysis, Inc.  
P.O. Box 6617  
Arlington, VA 22206  
(703) 998-3060

Doug Clifford  
Chief Engineer  
Boeing Commercial Airplane Co.  
MS 6A-31 P.O. Box 3707  
Seattle, WA 98124  
(206) 251-3945

Donald Clobes  
CV-580 Program Manager  
Republic Airlines  
7500 Airline Drive  
Minneapolis, MN 55450  
(612) 726-06707

Robert F. Clossin  
Structural Engineer  
Cessna Aircraft Co.  
P.O. Box 7704  
Dept. 175  
Wichita, KS 67277  
(316) 946-7268

George T. Coen  
Office Manager  
Federal Aviation Administration  
FSDO P.O. Box 17325  
Dulles Airport  
Washington, DC 20041  
(202) 557-5360

Walter S. Coleman  
Director — Operations  
Air Transport Association  
1709 New York Avenue, N.W.  
Washington, DC 20006  
(202) 626-4015

Ed Colodny  
President  
USAir  
Greater Pittsburgh International  
Airport  
Pittsburgh, PA 15231

Lora Compton  
Flight Attendant Instructor  
Eastern Airlines  
1091 Bass Point Road  
Miami Springs, FL 33166  
(305) 873-6163

K.W. Comstock  
Manager of Interiors Engineering  
United Airlines, Maintenance  
Operations Division  
San Francisco International  
Airport  
San Francisco, CA 94128  
(415) 786-6025

Phyllis Conrad  
Political Liaison — DCA  
Association of Professional Flight  
Attendants  
1004 West Eules Blvd.  
Eules, Texas 76040  
800-433-7026

Rene Cosnotti  
Acting Manager  
Quality & Performance F/A  
Services  
USAir  
419 Meade Drive  
Coraopolis, PA 15108  
(215) 412-262

Mark Courtney  
Manager, Member Service  
National Air Transportation  
Association  
4226 King St.  
Alexandria, VA 22302  
(703) 845-9000

Cathy Covey  
Manager, Training Cabin Services  
Wardair Canada  
3111 Convair Dr.  
Mississauga, Ontario,  
Canada L5P 1C2  
(416) 617-1285

Dennis J. Crabtree  
Director, Safety Evaluation  
Continental Airlines  
Houston, TX 77019  
(713) 630-6623

Charles R. Crane  
Chief, Biochemistry Research  
Aviation Toxicology Laboratory  
FAA, Civil Aeromedical Institute  
P.O. Box 25082  
Oklahoma City, OK 73125  
(405) 749-4866

Charles B. Cross  
Manager F/A Training  
Piedmont Airlines  
P.O. Box 2720  
Winston-Salem, NC 27156  
(919) 767-5376

James W. Danaher  
Director, Bureau of Technology  
National Transportation Safety  
Board  
800 Independence Avenue, S.W.  
Washington, DC 20594  
(202) 382-6610

Joe Danon  
Principal Engineer  
Scott Aviation  
225 Erie St.  
Lancaster, NY 14086  
(716) 683-5100

Mary Kay Davies  
Interim Directo — Health &  
Safety  
Independent Union of Flight  
Attendants  
Pan Am  
116 Alpha St.  
Belle chasse, LA 70037  
(504) 391-1359

Alvin D. Delman  
Manager, Testing Services  
The Wool Bureau, Inc.  
225 Crossways Park Drive  
Woodbury, NY 11797  
(516) 364-0890

Robert Dodd  
Staff Engineer  
Airline Pilots Association  
1625 Mass. Ave., N.W.  
Washington, DC 20036  
(202) 797-4191

Thomas Dodds  
Program Analyst  
Office of Industry Policy  
Office of the Secretary  
U.S. Department of  
Transportation  
Nassif Bldg.  
400 7th Ave., S.W.  
Washington, DC 20590  
(202) 426-2916

Paul S. Donohoe  
Branch Manager,  
Operations/Airworthiness  
FAA — Alaskan Region  
2424 Captain Cook Dr.  
Anchorage, AK 99503  
(907) 271-5906

James E. Dougherty  
Aviation Consultant  
General Aviation Manufacturers  
Association  
1400 K Street, N.W.  
Washington, DC 20005  
(202) 393-1500

Bernard C. Doyle  
5807 Wiltshire Drive  
Bethesda, Maryland 20016



Paschal Dsanitsaris  
Ontario Research Foundation  
Sheridan Park Research  
Community  
Mississauga Ontario,  
Canada L5K-1B3  
(416) 822-4111 x310

Martin Dubovy  
Manager, Research and  
Development  
Douglas Aircraft  
3855 Lakewood Blvd.  
Long Beach, CA 90846  
(213) J 593-7256

Carroll DuBuc  
Senior Partner  
Finley Kumble  
1120 Connecticut Ave., N.W.  
Washington, DC 20006  
(202) 857-4475

H.R.F. Duffell  
Head Mechanical and Fluid  
Systems  
Civil Aviation Authority  
Airworthiness Division  
Brabazon House  
Redhill  
Surrey, England 65966

H.H. Duffey  
Project Engineer  
American Airlines  
Tulsa International Airport  
3800 N. Mingo Road  
Maintenance Engineering Center  
Tulsa, OK 74114  
(918) 832-2347

Phyllis A. Duncan  
Associate Editor  
Federal Aviation Administration  
800 Independence Ave., S.W.  
Washington, DC 20591  
(202) 426-3903

Barbara Dunn  
National Safety Chairperson  
Canadian Airline Flight  
Attendants' Assoc.  
#860-1200 West 73rd Ave.  
Vancouver, British Columbia,  
Canada V6P 6G5  
(604) 266-1421

Donald William Dwyer  
Air Safety Investigator  
Federal Aviation Administration  
800 Independence Ave., S.W.  
Washington, DC 20591  
(202) 426-3120

Mack W. Eastburn  
Senior Director Safety  
American Airlines, Inc.  
P.O. Box 619616  
Dallas/Fort Worth Airport  
Dallas, TX 75261-9616  
(817) 355-1066

W. Locke Easton  
Aeospace Engineer  
FAA — New England Region  
12 New England Executive Park  
Burlington, MA 01830  
(617) 273-7088

Barry L. Eberhardt  
Supervisor, Systems Technology  
Boeing Co.  
P.O. Box 3707  
Seattle, WA 98124  
M/S OT-15

Randy Edwards  
ORD Base Chair  
Association of Professional Flight  
Attendants  
1004 West Eules Blvd.  
Eules, TX 76040  
800-433-7026

Lynne Egge  
Director — Government Affairs  
Independent Union of Flight  
Attendants  
Pan Am  
1814 Edge Hill Drive  
Alexandria, VA 22307  
(703) 765-2302

Jeanne M. Elliott  
Inflight Service Representative  
Republic Airlines, Inc.  
310 South 327th Lane  
Federal Way, WA 98003  
(206) 838-5149

Fred J. Emery  
President  
Fred Emery Associates  
1511 K Street, N.W.  
Suite 545  
Washington, DC 20005  
(202) 628-1408

John H. Enders, Honorable  
President  
Flight Safety Foundation, Inc.  
5510 Safety Foundation, Inc.  
5510 Columbia Pike  
Arlington, VA 22204-3194  
(703) 820-2777

John Enga  
Airworthiness Inspection  
Specialist  
FAA — Great Lakes Region Office  
2300 E. Devon Ave.  
Des Plaines, IL 60018  
(312) 694-7350

Donald D. Engen, Honorable  
Administrator  
Federal Aviation Administration,  
AOA-1  
800 Independence Ave., S.W.  
Washington, DC 20591

Mary Terese Enk  
Vice President  
Total Flood Corporation  
1409 Plaza Center  
Blue Springs, MO 64015  
(816) 524-6300

William A. Enk  
President  
Total Flood Corporation  
1409 Plaza Center  
Blue Springs, MO 64015  
(816) 524-6300

G.P. Ewald  
Manager of Firex Products  
Walter Kidde  
Route 1 Airport Road  
Wilson, NC 27893  
(919) 237-7004

Soren Ewaldsson  
Certification Engineer  
SAAB-Scania AB  
Fack Linkoping, Sweden S-58188  
13-182761

Roscoe Ewalt  
Aviation Safety Inspector  
FAA-ACDO 34  
8160 Cooper Way E  
Invergrove Hts, MN 55075  
(612) 450-1550

William Fanning  
Manager, Technical Services  
National Business Aircraft  
Association  
One Farragut Square South  
Washington, DC 20006  
(202) 783-9000

Erich Feldkirchner  
Section Manager Cabin Interiors  
and Interior Material  
Technology  
Airbus Industrie  
Avenue Lucien Servanty  
Blagnac, France 31700  
(61) 93.36.30

Melvin Fielder  
Operation Unit Supervisor  
FAA-ACDO  
6201 34th Ave. South  
Minneapolis, MN 55450  
(FTS) 725-3337

M. Kay Figley  
In-flight Supervisor/Training  
Midway Express  
A.M.F.  
P.O. Box 592337  
Miami, FL 33159  
(305) 526-3627

Marshall Filler  
Assistant Counsel, Aviation  
U.S. Congress  
Committee on Public Works &  
Transportation  
Rayburn House Office Building  
Washington, DC 20515  
(202) 225-4472

Dr. Matthew Finucane  
Director of Air Safety  
Association of Flight Attendants  
1625 Massachusetts Ave., N.W.  
Washington, DC 20036  
(202) 328-5400

J. Roger Fleming  
Vice President — Operations  
Air Transport Association of  
America  
1709 New York Avenue, N.W.  
Washington, DC 20006  
(202) 626-4021

Robert Fraebel  
SLS Manager  
Air Cruisers Co.  
P.O. Box 180  
Belmar, NJ 07719  
(201) 681-3527

Dominic Franco  
Health & Safety Member — JFK  
Independent Union of Flight  
Attendants  
Pan Am  
17 Amalia Lane  
Commack, NY 11725  
(516) 499-2682

Francesco Friscia  
Supervisor, Emerg. Equip. &  
Safety Procedures  
Alitalia  
Fiumicino Airport  
Rome, Italy 00100  
6010-3050

William R. Fromme  
Director of Aviation Safety  
FAA, Office of Aviation Safety  
800 Independence Ave., S.W.  
Washington, DC 20591  
(202) 426-2604

Nancy Gabel  
Safety Representative DFW.I  
Association of Professional Flight  
Attendants  
1004 West Eules Blvd.  
Eules, TX 76040  
800-433-7026

Julius A. Ganoza  
Economist  
FAA — Office of Aviation Policy &  
Plans  
800 Independence Avenue  
Washington, DC 20590  
(202) 426-3070

David Gee  
Staff Engineer  
Beech Aircraft  
P.O. Box 85  
Wichita, KS 67201  
(316) 689-6557

Milton J. Getker  
International Marketing Manager  
Environmental Tectonics  
Corporation  
Southampton, PA 18966  
(215) 355-9100

Gordon A. Gilbert  
Senior Staff Editor  
Business & Commercial Aviation  
6 Garry Knolls  
Danbury, CT 06810  
(914) 948-1912

David Gill  
Instructor — Flight Attendant  
Training  
Continental Airlines  
2929 Allen Parkway, 13th Floor  
Houston, TX 77373  
(713) 603-5246  
Lawrence E. Gillespie  
Manager, Flight Operations  
Air Transport Association  
1709 New York Avenue, N.W.  
Washington, DC 20006  
(202) 626-4011

John Gillette  
Chief Pilot  
Campbell Taggart, Inc.  
8623 Lemmon St., Hangar E  
Dallas, TX 75209-5788  
(214) 358-9242

Lucien Gormont  
International Technical Staff  
Federal Aviation Administration  
800 Independence Ave., S.W.  
Washington, DC 20591  
(202) 426-3256

Barry Gosnold  
Chief, Development Engineer  
British Airways  
P.O. Box 10, Hounslow  
Middlesex, England, TW6-2JA  
(01) 750-5562

Paul Grafton  
Cabin Crew Supervisor  
British Airways  
TriStar House  
P.O. Box 6  
London (Heathrow) Airport  
North Hounslow, Middlesex  
England, TW6 2JR

Bonita Graham  
F/A Training/Inflight Supervisor  
Eastern Provincial Airways  
P.O. Box 178  
Elmsdale, Nova Scotia, Canada  
BON 1MO  
(902) 861-4030

George Graham  
Captain-Pilot  
Wardair Canada, Ltd.  
3111 Convair Drive  
Mississauga Ontario, Canada  
L5P 1C2  
(416) 671-1444

Paul H. Greenlee  
Technical Director - Grimes  
Division  
Midland-Ross Corporation  
550 Route 55  
P.O. Box 247  
Urbana, OH 43078  
(513) 652-1431

Terrance J. Greifenberger  
Flight Mechanic  
General Electric Company  
Hangar E, Westchester County  
Airport  
White Plains, NY 10604  
(914) 948-6517

Thomas Guastavino  
Fuel Fire Safety Engineer  
FAA-Technical Center ACT-350  
Atlantic City Airport  
Atlantic City, NJ 08405  
(609) 641-6909

Diane Hall  
Customer Service Manager  
People Express  
Newark Airport  
Newark, NJ 07144  
(201) 961-2929

barry Halsted  
Manager, Technical Service  
Symbolic Displays  
P.O. Box 19626  
Irvine, CA 92713  
(714) 261-8202

J. Hannifin  
Chief Aerospace Correspondent  
Time, Inc. #850  
1050 Commonwealth Ave., NW  
Washington, DC 20036-5334  
(202) 861-4000

Kaj Juel Hansen  
Flight Crew Instructor  
Scandinavian Airline System  
SAS — Copenhagen Airport 2770  
Denmark  
01-509-111, Ext. 3097

Alan Hardisty  
Flight Safety Officer  
Air Canada  
P.O. Box 489  
RRI Hudson  
Montreal, Quebec, Canada  
(514) 636-2467

Janna Harkrider  
Co-Safety Chairperson  
Union of Flight Attendants,  
Local #1  
8639 Lincoln Blvd. Suite 200  
Los Angeles, CA 90045  
(213) 670-5591

Steve Harmon  
Development Engineer  
Celanese Corp.  
P.O. Box 32414  
Charlotte, NC 28232  
(704) 554-3382

Tom Harmon  
Manager, Distributor, Aviation  
Scott Aviation  
225 Erie St.  
Lancaster, NY 14086  
(716) 683-5100

Bill Hendricks  
Chief, Aviation Accident Division  
National Transportation Safety  
Board  
800 Independence Ave., S.W.  
Washington, DC 20594  
(202) 382-6830

Hendrick J. Hendriks  
Head, Emergency Equipment and  
Procedures  
KLM Royal Dutch Airlines  
Amsterdamseweg 55  
Amstelveen, Holland 1182GP  
020-491845

Richard Herrera  
Engineer  
Gulfstream Aerospace  
P.O. Box 2206  
Savannah, GA 31402  
(921) 964-3494

Howard Hess  
Aviation Safety Inspector  
Federal Aviation Administration  
800 Independence Ave., S.W.  
Washington, DC 20591  
(202) 426-8094

David Heymsfeld  
Counsel, House Aviation  
Subcommittee  
Committee on Public Works and  
Transportation  
U.S. House of Representatives  
Room 2165, Rayburn Office Bldg.  
Washington, DC 20515  
(202) 225-9161

E. Arnold Higgins  
Supervisor, Survival Research  
Unit  
Civil Aeromedical Institute, FAA  
AAC-119D  
P.O. Box 25082  
Oklahoma City, OK 73125  
(405) 686-4851

Billy G. Hill  
Program Analyst  
FAA — Office of Aviation Safety  
800 Independence Ave., S.W.  
Washington, DC 20591  
(202) 426-9472

Richard Hill  
Fire Safety Engineer  
FAA — Technical Center  
ACT-350  
Atlantic City Airport  
Atlantic City, NJ 08405  
(609) 641-5997

M.M. Hirschler  
Director, Chemical Group  
BF Goodrich  
Walker Road  
Avon Lake, OH 44012  
(216) 933-1789

Charles Hoch  
Manager, Safety Analysis Division  
FAA, Office of Aviation Safety  
800 Independence Ave., S.W.  
Washington, DC 20591  
(202) 426-8256

Fritz Hofmann  
Instructor/Deputy Manager  
Emergency Training Flight  
Operations  
Swissair Otie  
Zurich-Airport  
Switzerland CH-8508  
01/812-6135

Thomas D. Hopkins  
Visiting Associate Professor  
School of Public Affairs  
University of Maryland  
College Park, MD 20742  
(301) 454-7240

S.M. Hooper  
Manager, Interiors, Engineer  
Eastern Airlines  
International Airport  
Miami, FL 33148  
(305) 873-7351

Andrew F. Horne  
Program Scientist Accident  
Investigation  
FAA, Office of Aviation Medicine  
800 Independence Ave., S.W.  
Washington, DC 20591  
(202) 426-3433

Wayne Howell  
Manager, Fire Safety Branch  
ACT-350  
FAA — Technical Center  
Atlantic City Airport  
Atlantic City, NJ 08405  
(609) 641-5150

William A. James  
Manager — Flight Training  
American Airlines  
6647 Lakewood  
Dallas, TX 75214  
(817) 355-5142

Diane Jefferson  
Flight Attendant Instructor  
McDonnell Douglas Aircraft  
3855 Lakewood Blvd.  
Long Beach, CA 90846  
(213) 595-2806

Rinse Jellema  
Chief Aircraft Safety Engineer  
Fokker b.v.  
P.O. Box 76f00 Schiphol  
The Netherlands 1117 2J  
(020) 544-3087

Fred Jenkins  
Crashworthiness Specialist  
FAA, ANM-130L  
4344 Donald Douglas Drive  
Long Beach, CA 90808  
(213) 548-2831

Allison Johnson  
Supervisor  
Delta Airlines  
Atlanta International Airport  
Atlanta, GA 30320  
(912) 765-2189

Daniel Johnson  
President  
Interaction Research Corp.  
2002 E. State  
Olympia, WA 98506  
(206) 357-4454

Gilbert Johnson  
Manager, Hydromechanical  
Engineering  
Republic Airlines  
7500 Airline Drive  
Minneapolis, MN 55450  
(612) 726-7649

Dick Jones  
Federal Aviation Administration  
ADA-1  
800 Independence Ave., S.W.  
Washington, DC 20591  
(201) 426-3111

Leroy A. Keith  
Manager  
Aircraft Certification Division  
Federal Aviation Administration  
Northwest Mountain Region  
17900 Pacific Highway South,  
C-68966  
Seattle, WA 98168  
(206—) 431-2100

George L. Kempf  
Engineering Manager  
SAE A-20C Chairman  
Bell Industries Illuminated  
Displays Div.  
18225 NE 76th St.  
Redmond, WA 98052  
(206) 885-4353

Toni Ketchell  
Safety Administrator  
Association of Professional Flight  
Attendants  
1004 West Euleus Blvd.  
Euleus, TX 76040  
(800) 433-7026

Nancy Kilch  
Senior Flight Attendant Instructor  
Delta Air Lines  
Atlanta International Airport  
Atlanta, GA 30320  
(912) 765-2885

Gary Killion  
Manager, Regulations Branch  
FAA — Northwest Mountain  
Region  
17900 Pacific Highway South  
Seattle, WA 98168  
(206) 431-2112

Mary K. King  
Manager Inflight-Service Training  
Republic Airlines  
Hartsfield International Airport  
Atlanta, GA 30320  
(404) 762-4611

KAI Kiock  
Director, Payload Systems  
Interior—Cargo—Emergency  
Airbus Industrie  
Avenue Lucien Servanty  
Blagnac, France 31700  
(61) 93.36.36

Warren Jones  
Manager, Cabin Interior  
Trans World Airlines  
P.O. Box 21026  
Kansas City Mo. Airport  
Kansas City, MO 64195  
(816) 8901-4644

John C. Kal  
Manager, Airport Operations  
Safety  
Federal Aviation Administration  
Airports, AAS-300  
800 Independence Ave., S.W.  
Washington, DC 20591  
(202) 426-3061

Muhammad Kalimat  
Chief Steward  
Alia Royal Jordanian Airlines  
Amman, Jordan

Linda Scott Kaufman  
Director, Flight Attendant Service  
Western Airlines  
6060 Avion Drive  
Los Angeles, CA 90045  
(213) 216-3185

Robert Y. Keegan, Jr.  
Aviation Safety Inspector  
FAA — Detroit Flight Standards  
District Office  
1265 Kuehne Avenue  
Ann Arbor, MI 48103  
(313) 372-23282

James H. Keeler  
Transportation Program Manager  
General Electric Co., Plastics  
Business Group  
One Plastics Ave.  
Pittsfield, MA 01201  
(413) 494-4652

William C. Keil  
Staff Director — Engineering/QA  
USAir  
Greater Pittsburgh International  
Airport  
Pittsburgh, PA 15237  
(412) 262-7266

Dick Kirsch  
Aircraft Safety Program Manager  
FAA, AWS-100  
800 Independence Ave., S.W.  
Washington, DC 20591  
(202) 426-8323

Verena Klemm  
Chairperson, Health & Safety  
—LON  
Independent Union of Flight  
Attendants

Pan Am  
P.O. Box 1731  
08034 Germering  
Munich, West Germany  
011.49.89.841.6299

Joyce Klein  
Manager, In-Flight Services, Inc.  
Eastern Airlines  
5731 N.W. 37 Street  
Virginia Gardens, FL 33166  
(305) 873-6163

Robert W. Kneisley  
Attorney  
Southwest Airlines  
1200 New Hampshire Ave.  
Suite 300  
Washington, DC 20036

Noreene Koan  
Chairperson, National Air Safety  
Committee  
Association of Flight Attendants  
United Airlines  
2448 Coronet Blvd.  
Belmont, CA 94002  
(415) 591-8795

Juergen Kummer  
Manager, Material Processing  
Messerschmidt Bolkow Blohm  
Huenefeldstrasse  
Bremen, F.R.G. 28  
49.42.15.381

John Kunkle  
First Officer  
MCI Communications  
Corporation  
P.O. Box 17440  
Dulles International Airport  
Washington, DC 20041

Judy Ladislaw  
Base Chairperson — DCA  
Association of Professional Flight  
Attendants  
1044 West Eules Blvd.  
Eules, TX 76040  
800-433-7026

Daniel Laing  
Aeronautical Engineer  
Ozark Airlines  
P.O. Box 10007  
Lambert St. Louis Airport  
St. Louis, MO 63145  
(314) 429-8556

Walter D. Lamon  
Aviation Safety Manager  
AETNA/CIGNA Flight Operations  
Bldg. 85-176 Bradley  
International Airport  
Windsor Locks, CT 06082  
(203) 627-9364

Gary Leegate  
Vice President  
DME Corporation  
111 Southwest 33rd Street  
Fort Lauderdale, FL 33315

Dee Lewis  
Manager, In-Flight Training &  
Scheduling  
Air Cal  
3636 Birch St.  
Newport Beach, CA 92660  
(714) 752-7000 or 8084

Allan Lewis  
Economist  
FAA — Office of Aviation Policy  
800 Independence Avenue, S.W.  
Washington, DC 20591  
(202) 426-3070

Sonja Ligthart  
Martinair Holland NV  
Martinair Bldg  
P.O. Box 7507  
1118ZG Schiphol-centrum  
Holland, The Netherlands  
020-153666

Bibiana H. Liu  
Secretary, Operations Div.  
China Airlines  
Sung-Shan Airport  
Taipei, Taiwan, Republic of China  
02/712-3141

C. David Lockman  
Engineering Project Manager  
Piedmont Airlines  
Smith Reynolds Airport  
Winston-Salem, N.C. 27156  
(919) 767-5637

D.K. Benny Lynch  
Manager, Passenger Safety  
Inspection  
Air Regulations, Transport Canada  
LCOP/L, Place DeVile  
Ottawa, Ontario,  
Canada K1A ON8  
(613) 992-5095

John H. Lyons  
Paralegal  
Paul, Hastings, Janofsky & Walker  
1050 Thomas Jefferson Street,  
N.W.  
Washington, DC 20007  
(202) 333-8500

Richard E. Macdonald  
Assistant Director, Aviation  
Programs  
Aerospace Industries Association  
1725 DeSales St., NW  
Washington, DC 20036  
(202) 429-4618

John C. Macidull  
Aerospace Engineer  
Federal Aviation Administration,  
ASF-300  
2832 B, S. Wakefield St.  
Arlington, VA 22206  
(703) 755-8088

John MacKinnon  
Transportation Safety Specialist  
Federal Aviation Administration  
Office of Aviation Safety  
800 Independence Ave., S.W.  
Washington, DC 20591  
(202) 755-8088

A.F. Madayag  
Special Projects Office, ACE-104  
Federal Aviation Administration  
601 E. 12th Street  
Kansas City, MI 64106  
(816) 374-5955

T. Madgwick  
Head, Fire Precaution Engineering  
British Aerospace PLC  
Aircraft Group  
Civil Division  
Filton House  
Briston BS99 7AR, England  
0272-693831

James H. Major  
Aerospace Engineer  
FAA — Southwest Region  
P.O. Box 1689  
Ft. Worth, TX 76101  
(817) 877-2549

Laurance Malara  
Inspector  
United Technologies  
400 Main Street  
East Hartford, CT 06108  
(203) 565-5071

Hans-Joachim Mallwitz  
Certification Engineer  
MBB Commercial Aircraft  
Division  
P.O. Box 950109 Ds103  
Hamburg 95, West Germany  
49-40-7437-3133

Arthur Marcozzi  
Director, Research and  
Development  
Toyad Corp.  
P.O. Box 30  
La Trobe, PA 15650  
(412) 537-9000

Ralph G. Marrujo  
VP Product Development  
Fairchild Burns Co.  
1455 Fairchild Road  
Winston-Salem, NC 27105  
(919) 744-1040

Nora Marshall  
Transportation Safety Specialist  
National Transportation Safety  
Board  
800 Independence Ave., S.W.  
Washington, DC 20594  
(202) 382-6574

Gerry F. Marsters  
Director of Airworthiness  
Transport Canada, DADL  
200 Kent Street  
Ottawa, Canada K1A ON8  
(613) 990-5511

John Martin  
146 Project Designer  
British Aerospace PLC  
Aircraft Group  
Civil Division  
Hatfield, Herts AL10 9TL  
England  
7072-62345

Karl-Erik Marteusson  
Assistant QA Flight Operation  
Scandinavian Airlines  
S-16187 Bromma, Sweden

Sigfried Yves Martin  
Engineer  
Avions Marcel Dassault-Breguet  
Aviation  
78 quai Carnot Saint Cloud  
Cedex, France 92214  
(1) 602-50-50

Margi Mason  
Manager, Centralized Training  
American Airlines  
P.O. Box 619618  
Dallas-Fort Worth International  
Airport  
Dallas, TX 75261-9618  
(817)-355-4125

Doug Massie  
Chairman, Cabin Safety  
Committee  
Canadian Air Line Pilots  
Association  
1300 Steeles Ave., East  
Brampton, Ontario  
Canada L6T 1A2  
(416) 453-8210

James L. McAbee, Jr.  
Commercial Business Manager  
IC1 Americas  
F.F. Chemicals, Specialty  
Chemicals  
Fairfax Road  
Wilmington, DE 19897  
(302) 575-3761

Francis H. McAdams  
Safety Counselor  
Air Transport Association of  
America  
1709 New York Avenue, N.W.  
Washington, DC 20006  
(202) 426-4237

Robert C. McClain  
Pilot-Captain  
Red Lobster Inns  
6770 Lake Ellenor Dr.  
Orlando, FL 32809  
(305) 851-0370 x2170

Matt McCormick  
Senior Engineer  
National Transportation Safety  
Board  
800 Independence Avenue  
Washington, DC 20594  
(202) 382-6629

Laurie McLain  
APFA Safety Rep. — DFW  
Association of Professional Flight  
Attendants  
1004 West Eules Blvd.  
Eules, TX 76040

John R. McLaughlin  
Staff Manager — Passenger  
Services  
USAir  
Greater Pittsburgh International  
Airport  
Pittsburgh, PA 15231  
(412) 262-7456

J. Corey McMillan  
Chief, Materials Technology  
Boeing Commercial Airplane  
Company  
P.O. Box 3707  
Seattle, WA 98124  
(206) 237-9725

Thomas E. McSweeney  
Manager, Aircraft Engineering  
Division  
Federal Aviation Administration  
800 Independence Ave., SW  
Washington, DC 20591  
(202) 426-8160

George Michel  
Manager, Technical Flight Safety  
Swissair  
Zurich, Switzerland

C. O. Miller  
President  
System Safety Inc.  
7722 Bridle Path Lane  
McLean, VA 22101  
(707) 356-5065

Mary Ellen Miller  
Safety Chairperson  
Independent Federation of Flight  
Attendants  
6301 Rockhill Road  
Suite 404A  
Kansas City, MO 64131  
(816) 444-3603

Susan Miller  
Central Safety Chairperson  
Association of Flight Attendants  
United Airlines  
2550 Colorado Blvd.  
Denver, CO 80204  
(303) 355-8853

Norman Y. Mineta, Honorable  
U.S. Congressman  
U.S. House of Representatives  
Rayburn House Office Bldg.  
Room 2165  
Washington, DC 02515

Martha Minter  
Manager F/A Training  
Alaska Airlines  
Box 68900  
Seattle, WA 98188  
(206) 431-7238

Christian Monteil  
Director, Performance Operations  
Engineering  
Airbus Industrie  
BF N°33  
Blagnac 31700, France

Rosemary Morris  
Inflight Supervisor  
Midway Airlines, Inc.  
5700 S. Cicero  
Chicago, IL 60638  
(312) 838-4565

Hortencio G. Morsch  
Safety Advisor  
Varig Brazilian Airlines  
Av. Alm. Silvio Noronha, 365  
Rio de Janeiro, Brazil 20021

L.F. Mortimer  
Technical Officer  
International Civil Aviation  
Organization (ICAO)  
1000 Sherbrooke St., W  
Suite 400  
Montreal, Quebec,  
Canada H3A 2R2  
(514) 285-8155

Werner Muenster  
Manager, Interior Systems  
MBB, Commercial Aircraft  
Division  
P.O. Box 950109, D2103  
Hamburg, 95 West Germany  
49-40-74375615

Reagis P. Musgrove  
Field Service Representative  
U.S. Marine Corps  
S.O.E.S. Stop #21  
Mcas Cherry Point, NC 28533  
(919) 447-1043

Moin Amin Muzaffar  
Supervisor, Flight Attendant  
Safety Training  
Saudi Arabian Airlines  
Post Box 167, Cost Center 959  
JEDDAH — K.S.A.  
686-4328 JEDDAH

David Nay  
Director, Aviation Safety  
U.S. Marine Corp.  
Headquarters Marine Corp., ASA  
Washington, DC 20380  
(202) 694-2147

Marijka Nazarewycz  
Manager, In-Flight Training  
America West Airlines  
222 South Mill  
Tempe, AZ 85281  
(602) 894-0800

Richard Nelson  
Aerospace Engineer  
FAA Northwest Mountain Region  
Regulation and Policy Office  
17900 Pacific Highway South  
C-68966  
Seattle, WA 98168  
(206) 431-2112

Connie Nemes  
Central Region Safety  
Coordinator  
Association of Professional Flight  
Attendants  
1004 West Eules Blvd.  
Eules, TX 76040  
800-433-7026

Roberto Nin  
Vice Chairperson SJU  
Association of Professional Flight  
Attendants  
1004 West Eules Blvd.  
Eules, TX 76040  
800-433-7026

Denise Noe  
Manager, Procedures and  
Training, In-Flight Services  
Eastern Airlines  
Building #16 MIAFH  
International Airport  
Miami, FL 33148  
(305) 873-3138

Dennis A. Nollen  
Research Chemist  
E.I. Dupont DeNemores & Co.  
701 Building, Chestnut Run  
Wilmington, DE 19898  
(302) 999-2901

Alexandria B. Noller  
Manager, Crew Safety Procedures  
& Training  
Pan American World Airways  
5000 NW 36th St.  
Miami, FL 33166  
(305) 874-6673

Janice E. Northcott  
Inflight Services Safety Manager  
United Airlines  
P.O. Box 66100  
Chicago, IL 60666  
(312) 952-4438

Anna-Karin Oberj  
Engineer, Interior & Safety  
Standards  
Scandinavian Airlines  
S16187  
Stockholm, Bromma,  
Sweden 16187  
08-780-2311

Anne O'Connor  
Flight Attendant  
People Express  
North Terminal  
Newark International Airport  
Newark, NJ 07114  
(201) 961-8790

Leonard Oberlander  
Policy Analyst  
Federal Aviation Administration  
800 Independence Ave., S.W.  
Washington, DC 20591  
(202) 426-3070

Thomas O'Brien  
Flight Attendant  
Executive Air Fleet  
118 Billy Diehl Road  
Teterboro, NJ 07608  
(201) 288-8400

James Olavarria  
Industry Economist  
FAA — Policy & Plans  
800 Independence Ave., S.W.  
Washington, DC 20591  
(202) 426-3070

Dale Onderak  
Technical Director  
Schneller, Inc.  
6019 Powder Miller Rd.  
Kent, OH 44240  
(216) 673-1400

James Ott  
Transport Editor  
Aviation Week  
1777 N. Kent Street  
Arlington, VA 22207  
(703) 463-1781

James O. Ortiz  
Aviation Safety Inspector  
FAA, ACDO-Chicago  
2300 East Devon Ave.  
Des Plaines, IL 60018  
(FTS) 384-7266

David Ostrowski  
Technical Program Officer  
FAA Rotorcraft Program Office,  
ARO-1  
800 Independence Ave., S.W.  
Washington, DC 20591  
(202) 426-8748

A. Tom Peacock  
Douglas Aircraft company  
3855 Lakewood Blvd.  
Long Beach, CA 90846  
(213) 593-7156

William Perrella  
FAA — Aircraft Certification  
Office  
1790 Pacific Highway South  
C 68966  
Seattle, WA 98168  
(206) 431-2903

J. Petersen  
Instructor  
Maerskain  
Copenhagen Airport South  
Denmark  
0153-4444

James M. Peterson  
Materials Engineer  
Boeing Company  
Box 3707  
Seattle, WA 98124  
(206) 237-9725

Gordon Petri  
Manager, Inflight Technical  
Standards  
Pacific Western Airlines  
Internatioal Airport South  
Vancouver British Columbia,  
Canada V7B 1V2  
(604) 276-5743

Theodor Pfister  
Manager, Evacuation Procedures  
& Equipment  
Swissair  
8058 Zurich Airport  
Zurich, Switzerland  
01/812-7153

Peter Piersol  
Engineer  
Ontario Research Foundation  
Sheridan Park  
Mississauga, Ontario  
Canada M5K 1B3

Homero G. Pisco  
Engineer, Quality control  
Varig Airlines  
18 De Novembro, 800 Porto  
Alegre  
RS, Brazil 90000  
(0512) 424233

Frank Poliafico  
President  
Emergency & Safety Programs  
13 Northgate Village  
Media, PA 19063  
(215) 566-3680

B. Keith Potts  
Deputy Director of Aviation  
Safety  
FAA/Office of Aviation Safety  
800 Independence Ave., S.W.  
Washington, DC 20591  
(202) 426-2604

Marisue C. Prince  
Program Analysis Officer  
FAA, Office of Aviation Safety  
4559 King Edward Ct.  
Annandale, VA 22003  
(703) 426-2604

Edward Radkey  
Training & Safety Officer  
Marathon Oil, Aviation Division  
539 South Main St.  
Findlay, OH 45840  
(419) 422-2121, x2235

Paul G. Rasmussen  
Supervisor  
Emergency Evacuation Research  
Federal Aviation Administration  
P.O. Box 25082  
Oklahoma City, OK 73125  
(405) 868-4851

John Reed  
CID Program Manager  
FAA Technical Center  
Atlantic City airport  
Atlantic City, NJ 08405  
(609) 484-5147

John P. Reese  
Director, Aviation Programs  
Aerosapce Industries Association  
1725 DeSales St., N.W.  
Washington, DC 20036  
(202) 429-4666

Roy Reichenbach  
Assistant Division Manager,  
APM-701  
FAA, Aircraft Safety & Airport  
Technology  
800 Independence Ave., S.W.  
Washington, DC 20591  
(202) 426-8423

Arnold Reiner  
Director, Flight Analysis &  
Communications  
Pan American World Airways  
J.F.K. International Airport  
Hangar 14  
Jamaica, NY 11430  
(718) 632-5218

Ted Rist  
Captain  
Wayfarer Ketch Corp.  
Westchester County Airport  
White Plains, NY 10604  
(914) 949-4424

Marlene Rockstroh  
Safety Instructor  
Varig Brasilians Airlines  
Training Center  
429 Pasteur Ave., 5th Floor  
URCA  
Rio De Janeiro, Brasil

Marion F. Roscoe  
Director  
International Safety Consulting  
113 Tanglewood Drive  
Pauls Valley, OK 73075  
(9405) 238-6568

Henrique Ruhe  
Safety Instructor  
Varig Brasilians Airlines  
Training Center  
429 Pasteur Ave., 5th Floor  
URCA  
Rio De Janeiro, Brasil

Heinz Sagel  
Vauth-Sagel GmbH & Co.  
Neue Str. 27  
Brakel-Erkeln, West Germany  
3492  
05272/7047

Constantine Sarkos  
Technical Program Manager  
Federal Aviation Administration  
Technical Center  
ACT-350, Bldg. 201  
Atlantic City Airport, NJ 08405  
(609) 484-5620

David Schaffer  
Professional Staff  
U.S. Congress  
Subcommittee on Aviation  
Rayburn House Office Building  
Washington, DC 20515  
(202) 225-4472



Philip Schaenman

President  
Tri-Data  
1500 Wilson Blvd.  
Arlington, VA 22209  
(703) 841-2975

Edward M. Schew, Jr.  
Chairman  
Luminescent Systems, Inc.  
Etna Road  
Lebanon, NH 03766  
(603) 448-3444

Donald Schroeder  
Manager, Aircraft Safety  
Program, APR-710  
FAA, Program Engineering and  
Maintenance Service  
800 Independence Ave., S.W.  
Washington, DC 20591  
(202) 426-3593

Alan Scripture  
Aerospace Representative  
White Marketing, Inc.  
49011 "F" St.  
Omaha, NE 68117  
(402) 734-6600

Peter Seaman  
Safety Officer  
United Technologies  
400 Main St.  
East Hartford, CT 06108  
(203) 565-2131

Diane M. Sena  
Vice President  
Inflight Services  
United Airlines  
H.P.O. Box 6610  
Elk Grove Township, IL 60007

Beatriz Serrano  
Safety Officer, AirCal (TWU)  
Transport Workers Union of  
America  
1521 Rollins Road  
Burlingame, CA 94010-2388  
(714) 650-4514

Anne Seymour  
Director In-Flight Service  
Sun World International Airways  
2333 Renaissance Drive  
Las Vegas, NV 89109  
(702) 798-0088

William T. Shepherd  
Program Scientist  
FAA, Office of Aviation Medicine,  
AAM-550  
800 Independence Ave., S.W.  
Washington, DC 20591  
(202) 426-3177

M. Shiff  
Marketing Manager  
IAI International  
50 W. 23rd Street  
New York, NY 10010  
(212) 620-4472

William H. Shook  
Staff Engineer  
Douglas Aircraft Company  
3855 Lakewood Blvd.  
Long Beach, CA 90846  
(213) 593-5173

Joel L. Slotsky  
Senior Evaluator  
U.S. General Accounting Office  
Room 130, FAA Building  
800 Independence Ave., S.W.  
Washington, DC 20590  
(202) 426-8462

Karen Smith  
Recurrent Training Institute  
USAir  
2520 Holly Drive  
Pittsburgh, PA 15235  
(412) 262-7454

Kathy Snavelly  
Washington Safety Representative  
Transport Workers Union, Local  
553  
4930 Herkimer  
Annandale, VA 22003

Dave Snowdon  
Aviation Safety Specialist  
FAA, Southern Region, ASO-264  
3400 Norman Berry Drive  
East Point, GA 20636  
(404) 763-7421

Barry Snyder  
Flight Engineer  
Wayfarer Ketch Corporation  
Westchester County Airport  
White Plains, NY 10604  
(914) 949-4424

Stephen Soltis  
NRS-Crash Dynamics  
DOT/FAA  
4344 Donald Douglas Drive  
Long Beach, CA 90808  
(213) 548-2662

Cathy Spengel  
Eastern Region Safety  
Coordinator  
Association of Professional Flight  
Attendants  
1004 West Euleus Blvd.  
Euleus, TX 76040  
(800) 433-7026

Judy Spruill  
FAA, Office of Aviation Safety  
800 Independence Ave., S.W.  
Washington, DC 20591  
(202) 426-2604

Joseph Starkel  
FAA, Aircraft Certification Office,  
ANM-1005  
17900 Pacific Highway South,  
C-68966  
Seattle, WA 98168  
(206) 431-2903

Warren A. Stauffer  
Director of Engineering  
—Technology  
Lockheed-California Company  
P.O. Box 551  
Burbank, CA 91520  
(818) 847-5104

J.R. Stevens  
Technical Director  
Graviner Limited  
Poyle Road  
Colnbrook, Slough  
Berks, England SL3 OHB  
02812.3245

Albert Stewart  
Chief Engineer  
Heath Tigna Aerospace  
19819 84th Ave. S.  
Kent, WA 98938  
(206) 872-7500

Ted Stranczek  
President  
Total Flood Corporation Service  
Center  
6611 South Meridian  
Oklahoma City, OK 73159  
(800) 654-4492

William J. Sullivan  
Manager, Safety Regulations  
Division  
Associate Administration for  
Aviation Standards, FAA  
800 Independence Avenue, S.W.  
Washington, DC 20591  
(202) 426-7815

Hideo Suzuki  
Manager  
Flight Operations Engineering  
Japan Air Lines  
1-1 Hanedakuko, 2 Chome  
OTA-KU Tokyo, Japan  
03-747-3331

Stanley Switlik  
Director of Manufacturing  
Switlik Parachute Company  
1325 E. State St.  
Trenton, NJ 08607  
(609) 587-3300

Nancy Szmaida  
Customer Service Manager  
People Express  
Newark Airport  
Newark, NJ 07114  
(201) 961-8799

Earsa Tankesley  
Manager-Policy & Regulations  
FAA, Central Region Ace-110  
601 E. 12 St.  
Kansas City, MO 64106  
(816) 374-6930

Frank T. Taylor  
Director  
Aviation Safety Enterprises  
3542 Church Road  
Ellicott City, MD 21043  
(301) 465-3889

Wanda Lea Taylor  
Project Manager, Cabin Service  
Wardair Canada  
3111 Convair Dr.  
Mississauga, Ontario,  
Canada, L5P 1C2  
(416) 671-1285

Jerome Teplitz  
Consultant  
Flight Safety Foundation, Inc.  
5510 Columbia Pike  
Arlington, VA 22204-3194  
(703) 820-2777

Peterlyn Thomas  
Safety Coordinator of Flight  
Attendants  
Ansett Airlines of Australia  
Astrojet Centre  
Melbourne Airport  
Victoria, Australia 3045

Jody Thompson  
Chairperson-Safety-LAX  
Independent Union of Flight  
Attendants  
Pan Am  
2020 Farrell Ave. #4  
Redondo Beach, CA 90278  
(213) 379-9569

Robert Thurber  
Senior Policy Analyst  
Office of Industry Policy  
Office of the Secretary, P-10  
U.S. Department of  
Transportation  
Nassif Bldg.  
400 7th Ave., S.W.  
Washington, DC 20590  
(202) 426-2916

Siegfried Torbohm  
General Sales Manager  
Vauth & Sohn KG  
Hembser Str.1, 3492  
Brakel-Beller, Germany 3492  
05272-9191

Bruce Torrey  
Product Performance Specialist  
General Electric Company  
Plastics Business Group  
1 Plastics Avenue  
Pittsfield, MA 01201  
(413) 494-7629

Arno C. Trapp  
Engineering Technical Plan &  
Control Manager  
Varig Airlines  
18 De Novembro, 800 Pto. Alegre  
RS, Brazil 90000  
(0512) 42-4233

David Traynham  
Prof., Staff Member (Aviation)  
Committee on Public Works and  
Transportation  
2165 Rayburn House Office  
Building  
Washington, DC 20515  
(202) 225-9161

Thomas M. Tripp  
Manager, Technical Information  
Air Transport Association  
1709 New York Avenue, N.W.  
Washington, DC 20006  
(202) 626-4205

Wen-Pao Tsui  
Instructor  
China Airlines  
131 Nanking East Rd.  
Section 3  
Taipei, Taiwan  
Republic of China  
(02) 712-3143, Ext. 642

Michael W. Tyler  
Superintendent, Safety Studies  
Canadian Aviation Safety Board  
Hotel de Ville,  
Hull, Quebec, Canada  
(514) 994-4633

Francoise Van Kammen  
Flight Safety Instructor  
Fokker BV  
P.O. Box 76f00  
Schiphol, The Netherlands 1117  
ZJ

John D. Versaggi  
Director, Product Support  
Fairchild Burns Company  
1455 Fairchild Road  
Winston-Salem, NC 27105  
(919) 744-1015

H.J. Versteegen  
Manager Construction and  
Interior  
KLM Royal Dutch Airways  
P.O. 7700 - 1117 ZL  
Schiphol Airport  
Amsterdam, Netherlands  
027-491-415

John Vincent  
Technical Representative Seattle  
Qantas Airways  
Box 3707 MS OC-95  
Seattle, WA 98124  
(206) 644-0456

Steven Vincent  
Chairperson  
Aircraft Technical Committee  
Association of Flight Attendants  
Alaska Airlines  
412 Bellevue Ave., East, #304  
Seattle, WA 98102  
(206) 324-2049

Melvin E. Volz  
Vice President  
Flight Safety & Industry Affairs  
United Airlines  
P.O. Box 66100  
Chicago, IL 60666  
(312) 952-4557

Ray Walder  
Director, Engineering &  
Environmental Dept.  
International Air Transport  
Association  
2000 Peel Street  
Montreal, Quebec,  
Canada H3A 2R4  
(514) 844-6311

Steve Waldrip  
Structures Engineer  
Republic Airlines  
7500 Airline Drive  
Minneapolis, MN 55423  
(612) 726-6787

Gerrit J. Walhout  
Chief, Survival Factors Division  
National Transportation Safety  
Board  
800 Independence Ave., SW  
Washington, DC 20594  
(202) 3822-6628

James M. Wallace  
Aviation Medical Officer  
Health and Welfare Canada  
4900 Yonge St.  
Suite 300  
Willowdale, Ontario  
Canada M2N 6A5  
(416) 224-3144

Peggy Walrod  
Safety Representative  
Association of Professional Flight  
Attendants  
1004 West Euleess Blvd.  
Euleess, TX 76040  
800-433-7026

Udo G. Wargenau  
Manager, Cabin Engineering  
Lufthansa German Airlines  
Airport Area West-1F5 D6000  
Frankfurt, West Germany  
69-69427

Kenton D. Warner  
Chemical Products Manager  
Puritan-Bennett Aero Systems Co.  
10800 Pflumm Road  
Lenexa, KS 66215  
(913) 888-4000

Daniel Warnick  
Pilot  
MCI, Flight Operations  
P.O. Box 17440  
Dulles International Airport  
Washington, DC 20041  
(703) 661-8821

Dale S. Warren  
Director, Air Frame Technologies  
Douglas Aircraft Company  
38955 Lakewood Blvd.  
Long Beach, CA 908a46  
(213) 593-5173

Bill Weeks  
Captain  
ALPA  
446 Brittany Ct.  
Winston-Salem, NC 27103  
(919) 765-5348

Brenda Wells  
Instructor, Flight Attendant  
Training, Continental Air  
2929 Allen Pkwy  
Houston, TX 77373  
(713) 630-5246 x5256

Mimi Westbrook  
Safety Representative — DCA  
Association of Professional Flight  
Attendants  
1004 West Euleess Blvd.  
Euleess, TX 76f040  
800-

Lawson White  
Director, Flight Operation  
Services  
International Air Transport  
Association  
2000 Peel Street  
Montreal, Quebec,  
Canada H3A 2R4  
(514) 844-6311

Peter Wilander  
Specialist In-Flight Service Line  
Training  
Eastern Airlines  
Building #16 MIAFH  
International Airport  
Miami, FL 33148  
(305) 873-3158

Wayne E. Williams  
President  
National Transportation Safety  
Association  
8000 N. Ocean Drive  
Dania, FL 33084  
(305) 475-7487

Judi Wilmore  
Safety Co-Chairperson  
Union of Flight Attendants  
8639 Lincoln Blvd., Suite 200  
Los Angeles, CA 90045

Lilla Wilson  
President  
Jetco Safety Training  
37 Longfellow Drive  
Huntington St., NY 11746  
(516) 549-4285

Mile Wilson  
Marketing Manager  
Safety Training Systems, Inc.  
51512 South 110th East Ave.  
Tulsa, OK 74146  
(918) 665-0125

Roger L. Windblade  
Assistant Director for Aeronautics  
National Aeronautics and Space  
Administration  
600 Independence Ave.  
Washington, DC 20546  
(202) 453-2805

Daniel M. Wingard  
U.S. Marine Corps  
SOES, Stop 21, MCAS  
Cherry Point, NC 28532  
(919) 447-1700

Loretta Wishne  
Flight Attendant Instructor  
Ozark Airline  
P.O. Box 10007  
St. Louis, MO 63145  
(314) 429-8443

Richard Witkin  
Aviation Editor  
New York Times  
229 W. 43rd Street  
New York, NY 10036  
(212) 517-1087

Chris Witkowski  
Aviation Consumer Action Project  
1346 Connecticut Ave., N.W.  
Suite 717  
Washington, DC 20036  
(202) 223-4498

Gilbert Wittlin  
Research and Development  
Engineer  
Aeromechanics Division-Lockheed  
Calif. Co.  
P.O. Box 551  
Burbank, CA 91520  
(818) 847-3835

Edward C. Wood  
Director  
Engineering and Maintenance  
Flight Safety Foundation, Inc.  
5510 Columbia Pike  
Arlington, VA 22204-3194  
(703) 820-2777

William D. Wood  
Chief, Aviation Safety Division  
U.S. Department of  
Transportation  
Kendall Square  
Cambridge, MA 02142

**END**

**FILMED**

**12-85**

**DTIC**