

2



US ARMY  
MATERIEL COMMAND



**M**ANUFACTURING  
**M**ETHODS &  
**T**ECHNOLOGY

**PROJECT SUMMARY  
REPORTS**

FILE COPY

JUNE 1985  
PREPARED BY

USA INDUSTRIAL BASE ENGINEERING ACTIVITY  
MANUFACTURING TECHNOLOGY DIVISION  
ROCK ISLAND, ILLINOIS 61299-7260

85 09 12 025

REPORT DOCUMENTATION PAGE		READ INSTRUCTIONS BEFORE COMPLETING FORM
1. REPORT NUMBER	2. GOVT ACCESSION NO. <b>AD-A159360</b>	3. RECIPIENT'S CATALOG NUMBER
4. TITLE (and Subtitle)  MANUFACTURING METHODS AND TECHNOLOGY PROJECT SUMMARY REPORTS		5. TYPE OF REPORT & PERIOD COVERED  Semi-Annual - Jan - June 85
		6. PERFORMING ORG. REPORT NUMBER
7. AUTHOR(s)  Manufacturing Technology Division US Army Industrial Base Engineering Activity		8. CONTRACT OR GRANT NUMBER(s)
9. PERFORMING ORGANIZATION NAME AND ADDRESS  US Army Industrial Base Engineering Activity ATTN: AMXIB-MM Rock Island, IL 61299-7260		10. PROGRAM ELEMENT, PROJECT, TASK AREA & WORK UNIT NUMBERS
11. CONTROLLING OFFICE NAME AND ADDRESS  HQ AMC, US Army Materiel Development and Readiness Command, ATTN: AMCMT, 5001 Eisenhower Avenue, Alexandria, VA 22333-0001		12. REPORT DATE  June 85
		13. NUMBER OF PAGES  129
14. MONITORING AGENCY NAME & ADDRESS (if different from Controlling Office)		15. SECURITY CLASS. (of this report)
		15a. DECLASSIFICATION/DOWNGRADING SCHEDULE
16. DISTRIBUTION STATEMENT (of this Report)  Distribution unlimited. Document for public release		
17. DISTRIBUTION STATEMENT (of the abstract entered in Block 20, if different from Report)  Distribution unlimited. Document for public release.		
18. SUPPLEMENTARY NOTES		
19. KEY WORDS (Continue on reverse side if necessary and identify by block number)  Manufacturing methods Manufacturing technology Technology transfer MMT Program		
20. ABSTRACT (Continue on reverse side if necessary and identify by block number)  This report contains summaries of 47 projects that were completed under the Army's Manufacturing Methods and Technology (MMT) Program. The MMT program was established to upgrade manufacturing facilities used for the production of Army Materiel. The summaries highlight the accomplishments and benefits of the projects and the implementation actions underway or planned. Points of contact are also provided for those who are interested in obtaining additional information.		



DEPARTMENT OF THE ARMY  
 US ARMY INDUSTRIAL BASE ENGINEERING ACTIVITY  
 ROCK ISLAND, ILLINOIS 61299

REPLY TO  
 ATTENTION OF:

AMXIB-M

16 July 1985

SUBJECT: Manufacturing Methods and Technology Program Project Summary  
 Report (RCS DRCMT-302)

SEE DISTRIBUTION (Appendix II to Enclosure 1)

1. In compliance with AR 700-90, dated 15 March 1982, the Industrial Base Engineering Activity (IBEA) has prepared the enclosed Project Summary Report.
2. This Project Summary Report is a compilation of MMT Summary Reports prepared by IBEA based on information submitted by AMC Major Subordinate Commands and project managers. These projects represent a cross section of the type of efforts that are being conducted under the Army's Manufacturing Methods and Technology Program. Persons who are interested in the details of a project should contact the project officer indicated at the conclusion of each individual report.
3. Additional copies of this report may be obtained by written request to the Defense Technical Information Center, ATTN: TSR-1, Cameron Station, Alexandria, VA 22304-6145.

*James W. Carstens*  
 JAMES W. CARSTENS  
 Chief, Manufacturing Technology Division

Encl

Accession For	
NTIS GRA&I	<input checked="" type="checkbox"/>
DTIC TAB	<input type="checkbox"/>
Unannounced	<input type="checkbox"/>
Justification	
By	
Distribution/	
Availability Codes	
Dist	Avail and/or Special
A1	



## TABLE OF CONTENTS

	<u>PAGE</u>
Disclaimer	Inside Front Cover
Introduction	1
Highlights of Noteworthy Projects	3

### CAD/CAM

<u>Project G83 0002</u> - Application of Robotics to Shelter Refinishing	C-1
<u>Project 483 5005</u> - Establishment of a Computer-Aided Design (CAD)/Computer-Aided Manufacturing (CAM) Process for the Production of Cold Forged Gears	C-4
<u>Project 483 6121</u> - Robotic Welding and Weld Seam Tracking for the Bradley Fighting Vehicle (BFV), Phase I	C-7
<u>Project 782 8192</u> - Turbine Engine Productivity Improvement	C-10

### ELECTRONICS

<u>Project H80 3510</u> - Transducer Process Technology for Microwave Delay Lines	E-1
<u>Project 084 5071-57</u> - General Purpose Bit-Slice Minicomputer Interface	E-4
<u>Project E82 3796</u> - Combat Vehicle Deperming Production Facility	E-6

Tables of Contents (Continued)

	<u>Page</u>
<u>INSPECTION AND TEST</u>	
<u>Project 0 5071-71</u> - Improved Copper Crusher Pressure Gages	I-1
<u>Project 082 5071-100</u> - Automated Particle Contamination Measurement in Hydraulic Fluids	I-4
<u>Projects 580, 83 0900</u> - Automated Multiple Filter Life Tester	I-6
<u>Project 581 1907</u> - Automated Gaging for Medium Caliber Projectile Bodies	I-9
<u>Project 682 8370</u> - Automatic Inspection and Process Control of Weapons Parts Manufacturing	I-11
<u>METALS</u>	
<u>Project 181 7285</u> - Cast Titanium Compressor Impellers	ME-1
<u>Project 182 7366</u> - Spiral Self-Acting Seals	ME-3
<u>Project 383 1086</u> - Cobalt Replacement in Maraging Steel for Rocket Motor Components	ME-4
<u>Project T82 5090</u> - Improved and Cost Effective Machining Technology (Phase IV)	ME-7
<u>Projects 480, 82 6059-06</u> - M2 and M3 Fighting Vehicle System - Laser Heat Treating	ME-9
<u>Project 679 7482</u> - Modified Ribbon Rifling Generating Machine	ME-12
<u>Project 682 8050</u> - Recycling Spent Gun Tubes by ESR Melting	ME-15
<u>Project 682 8113</u> - Establishment of Ion Plating Process for Armament Parts	ME-18
<u>Project 681 8152</u> - Improved Anode Straightness for Chromium Plating	ME-21
<u>Project 682 8242</u> - Dual Press Straightening Gun Tubes	ME-24
<u>Projects 782, 82 8190</u> - Improved Blisk Impeller Cutter Life	ME-27

Tables of Contents (Continued)

	<u>Page</u>
<u>MUNITIONS</u>	
<u>Project 580 4210</u> - Jet Cutting of Energetic Materials	MU-1
<u>Project 581 4231</u> - In-Plant Reuse of Pollution Abated Waters	MU-5
<u>Project 581 4267</u> - Granular Process for Composition B	MU-8
<u>Project 583 4298</u> - Evaluation of DMN Disposal on Holston AAP B-line	MU-11
<u>Project 583 4453</u> - Determination of Spacing of Munition Items to Prevent Propagation	MU-14
<u>Project 580 4484</u> - Improved Hi-Speed Waterproofing Applicator for Small Caliber Ammunition	MU-17
<u>Project 582 4560</u> - Mod Tape-Stiffener Assembly Process, M42/M46 Grenades	MU-19
<u>NON-METALS</u>	
<u>Project 383 1089</u> - Integral Rocket Motor Composite Attachments	N-1
<u>Projects 383, 84 1126</u> - Wound Elastomer Insulator Process	N-3
<u>Project 382 3423</u> - Low Cost/High Performance Carbon-Carbon Nozzles	N-5
<u>Projects 476, 77, 83 5052</u> - Army Engineering Design Handbook for Production Support	N-7
<u>Task 483 6107-02</u> - Adaptive Fluidic Damper	N-9
<u>Projects 478, 79 1335</u> - Manufacturing Techniques for New Protective Mask	N-12
<u>Projects 580, 81, 82 1335</u> - Machining Techniques for New Protective Mask	N-15
<u>Project E79 3532</u> - Molten Salt Lithium/Chlorine Battery	N-18

Tables of Contents (Continued)

Page

APPENDIX I

Army MMT Program Offices

AI-1

APPENDIX II

Distribution

AII-1

## INTRODUCTION

### Background

The Manufacturing Methods and Technology (MMT) Program was established to upgrade manufacturing facilities used for the production of Army materiel, and as such, provides direct support to the Industrial Preparedness Program. The Manufacturing Methods and Technology Program consists of projects which provide engineering effort for the establishment of manufacturing processes, techniques, and equipment by the Government or private industry to provide for timely, reliable, economical, and high-quality quantity production means. The projects are intended to bridge the gap between demonstrated feasibility and full-scale production. The projects are normally broad based in application, are production oriented, and are expected to result in a practical process for production. The projects do not normally include the application of existing processes, techniques, or equipment to the manufacture of specific systems, components, or end items, nor do they apply to a specific weapon system development or a product improvement program.

### MMT Program Participation

MMT Programs are prepared annually by AMC Major Subordinate Commands. These programs strive for the timely establishment or improvement of the manufacturing processes, techniques, or equipment required to support current and projected programs.

Project proposals (Exhibits P-16) are submitted to the appropriate MMT Program office. A list of offices is provided in Appendix I. Additional information concerning participation in the MMT Program can be obtained by contacting an office listed or by contacting Mr. James Carstens, AUTOVON 793-5113, or Commercial (309) 782-5113, Industrial Base Engineering Activity, Rock Island, IL 61299-7260.

In anticipation of the lengthy DOD funding cycles, projects must be submitted in sufficient time for their review and appraisal prior to the release of funds at the beginning of each fiscal year. Participants in the Program must describe manufacturing problems and proposed solutions in Exhibit P-16 formats (see AR 700-90, 15 March 1982, for instructions). Project manager offices should submit their proposals to the Command that will have mission responsibility for the end item that is being developed.

### Contents

This report contains summaries of 47 completed projects that were funded by the MMT Program. The summaries are prepared from Project Status Reports (RCS DRCMT-301) and Final Technical Reports submitted by organizations executing the MMT projects. The summaries highlight the accomplishments and



benefits of the projects and the implementation actions under way or planned. Points of contact are also provided for those interested in obtaining additional information.

The MMT Program addresses the entire breadth of the Army production base and, therefore, involves many technical areas. For ease of referral, the project summaries are grouped into six technical areas. The technical areas are: CAD/CAM, Electronics, Inspection and Test, Metals, Munitions, and Non-Metals. Abstracts were prepared to highlight projects which achieved noteworthy accomplishments.

This report was also organized and bound to facilitate its disassembly. A disassembled report may be used to selectively circulate certain summaries and for filing of selected summaries for future reference.

The Summary Reports are prepared and published for the Directorate for Manufacturing Technology, AMC, by the Manufacturing Technology Division of the US Army Industrial Base Engineering Activity (IBEA) in compliance with AR 700-90. The report was compiled and edited by Mr. Wayne R. Hierseman and ably assisted by Ms. Eileen Griffing and Ms. Lisa Anderson with the typing and graphics arrangements.

## HIGHLIGHTS OF NOTEWORTHY PROJECTS

<u>Project Number</u>	<u>Project Title</u>	<u>Page</u>
782 8192	Turbine Engine Productivity Improvement	C-10

It was recognized that the Stratford Army Engine Plant (SAEP) physical plant and equipment were substantially antiquated, as were its manufacturing methods and control systems. This project continues the analysis of the present (As-Is) total manufacturing operation and developing a conceptual design for the future (To-Be) factory. The conversion of the SAEP manufacturing operation from a "overgrown job shop" to a group technology oriented manufacturing facility is the thrust of the planned and on-going production improvement. Group technology offers for batch manufacturing some of the line flow efficiencies typically found in mass production. The design worked out to reorganize the factory is a well developed plan that has improved productivity, delivery, quality, as well as the working environment. Thus far, savings of \$12 million of indirect costs have been recognized against current aviation engine contracts. Another \$110 million in savings are projected for later implementation.

084 5071-57	General Purpose Bit-Slice Minicomputer Interface	E-4
-------------	--	-----

To satisfy the instrumentation requirements of Test and Evaluation Command (TECOM) projects, a unique bit-slice processor was designed for use on each project. Experience suggested that a general purpose computer interface might be designed that could be used on any project. This project began by studying bit-slice minicomputer interface (BSI) future requirements in order to determine the essential features. This caused some rethinking by the design engineers about controller design. However, the result was the development of a general purpose computer interface. The BSI is designed so that any system requiring a minicomputer interface can use it. It utilizes both an interrupt and direct memory access (DMA) scheme. Application of the BSI concept will help designers reduce engineering time spent on custom designing. Savings up to \$10,000 per project are projected.

Configuration requirements for medium caliber munitions are many and varied. The acceptance inspection system currently in use consists primarily of single attribute type inspection equipment which is very labor intensive. The purpose of this project was to design an automated acceptance inspection gaging system for medium caliber projectile bodies. After an automated system was determined to be feasible, a prototype system was built for data reduction. Finally, an automated inspection gage was built to supplement 20 standard gages now used. The resulting automated system is cheaper, faster, and more accurate. The present manual methods cost an average of 20¢/body overall. This is reduced to 10¢/body with an automated system. In addition, the latter system permits 100 percent inspection versus only 20 percent under the manual system.

Current high performance rocket motor components utilize maraging steel in large quantities. Although predominately a nickel-alloy, maraging steel historically has been heavily dependent on cobalt for its physical properties. This element is becoming increasingly difficult and frequently expensive to obtain. The objective of this last phase of the three-phase effort was to produce and test scaled-up solid rocket motor case assemblies made from maraging steel not containing cobalt (co-free). The program has conclusively demonstrated that co-free maraging steel is an acceptable alternative material for rocket motor components. Besides providing a strategic benefit of reducing United States dependency on foreign sources of cobalt, a savings of \$522,000 has been projected by MICOM.

Conservation of critical alloys that must be imported has become extremely important. Many gun tubes are regularly fired-out and discarded for scrap value at a great monetary loss. The objective of this project was to determine whether spent gun tubes could be remelted and salvaged by the electroslag refining (ESR) process. As it turned out, the ESR melting and subsequent forging and heat treating of the material produced a product with mechanical properties superior in quality to the material presently being used. Furthermore, it proved that the ESR process of remelting spent gun tubes will conserve critical alloy elements such as chrome, nickel, molybdenum, and vanadium that are required in high quality gun steel. Monetary savings of \$300 to \$700 per tube are projected.

**SUMMARY**

This project established the direction of the entire program by defining the overall problems and recommendations for an overall solution. Hence, the objective of this Phase II-A effort was to improve production at SAEP by reducing costs, enhancing timely delivery, and improving quality.

The conversion of the SAEP manufacturing operation from a "overgrown job shop" to a group technology oriented manufacturing facility is the thrust of the planned production improvement. Group technology offers for batch manufacturing some of the line flow efficiencies typically found in mass production with continuous line flow.

The parts to be produced at SAEP were grouped into families having similar manufacturing characteristics. The factory floor plan was arranged into cellular groups to produce parts in accordance to their family manufacturing characteristics. A three-dimensional scale model of the SAEP total floor plan, which was used to analyze the "As-Is" factory, was used to provide a conceptual design layout of the factory "To-Be." It was used in conjunction with a computer program modeling technique called IDEF (Integrated Computer Aided Manufacturing Definition) to develop a customized model for current operations and proposed changes.

The major emphasis of Phase II-A was to carry out detailed design of the total factory and act on specific improvement concepts (see figure 2). These were identified under Phase I to insure their integration into the total factory environment.

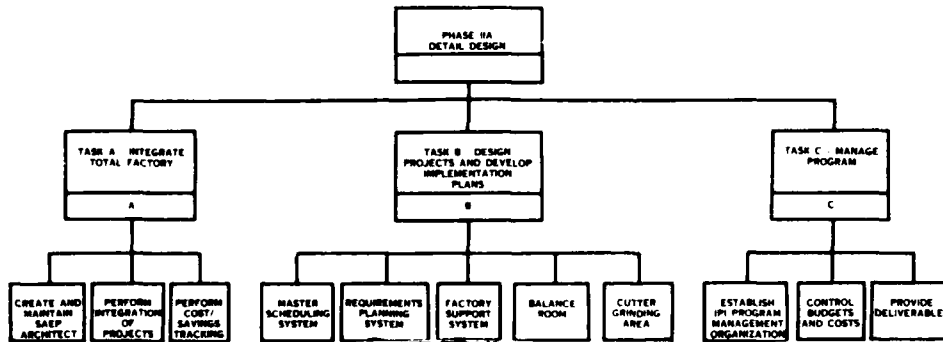

Figure 2 -  
Phase II-A  
Program

Phase II-A accomplished the completion of the detail design for an information system to improve master scheduling, factory support, and material requirements planning. The master scheduling system project provided an interactive simulation capability to balance the production schedule with resource capacity. The factory support system project provided design for computer-aided system to provide on-line transaction for expendable tools, routing sheets, processing sheets, inventory control of fixtures, gages and plant maintenance. An integrated systems architecture was structured in which one command data base shareable by all user functions will serve all of AVCO-Lycoming. This design defined the data elements, data relationship, and included specification of the types of communication devices required in

**MANUFACTURING METHODS AND TECHNOLOGY  
PROJECT SUMMARY REPORT  
(RCS DRCMT-302)**

MMT Project 782 8192 titled "Turbine Engine Productivity Improvement" was completed by the US Army Aviation Systems Command in September 1983 at a cost of \$2,559,000.

**BACKGROUND**

The AVCO Lycoming Division (ALD) operates the Stratford Army Engine Plant (SAEP) (see figure 1). They are the prime contractor of the AGT-1500, T-53 and T-55 turbine engines supporting both Army aviation and tank production. At the inception of this project, it was recognized that the SAEP physical plant and equipment were substantially antiquated, as were the manufacturing methods and control systems then being used. The proximate results of this situation were manifested in excessive cost, an inability to meet schedules, and quality problems - particularly on the AGT-1500 engine for the M1 Abram Tank.

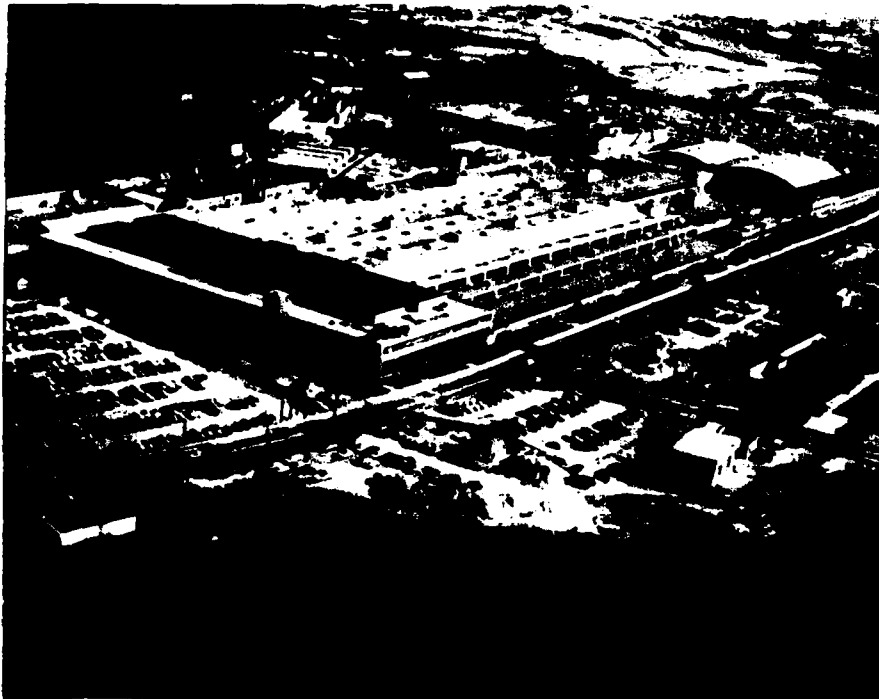

Figure 1 - Stratford Army Engine Plant

The first phase of this ongoing effort consisted of analyzing the present (As-Is) total manufacturing operation and to provide a conceptual design for the future (To-Be) factory. This project begins the second phase.

## **IMPLEMENTATION**

This project represents Phase I of a two-phase project. Phase II will apply the technology developed in Phase I to actual BFV joints. If Phase II is successful, the system will be used in the production of the BFV.

## **MORE INFORMATION**

To obtain additional information, contact the project engineer M. King, (313) 574-6065 or obtain a copy of the final technical report "Robotic Welding and Seam Tracking for the Bradley Fighting Vehicle," TR 13007, July 1984, from the US Army Tank-Automotive Command, ATTN: AMSTA-TSL, Warren, MI 48090.

---

Summary report, Jun 85, was prepared by F. Stonestreet, Manufacturing Technology Division, US Army Industrial Base Engineering Activity, Rock Island, IL 61299-7260

performed. System tracking was tested by moving the specimen off the programmed path with the tracking equipment energized. The robots ability to find the center of the weld joint was tested by locating the weld electrode within the area of the joint. The optical system was tested for its ability to track even if the weld specimen was not located on the proper path. In all tests the system performed as specified. The results of the study showed that the seam tracking system works as designed. The system is capable of correcting the weld path to compensate for a joint that may start near the preprogrammed start point and which deviates from the programmed path by as much as an inch in each of the two directions orthogonal to a 15" long weld path.

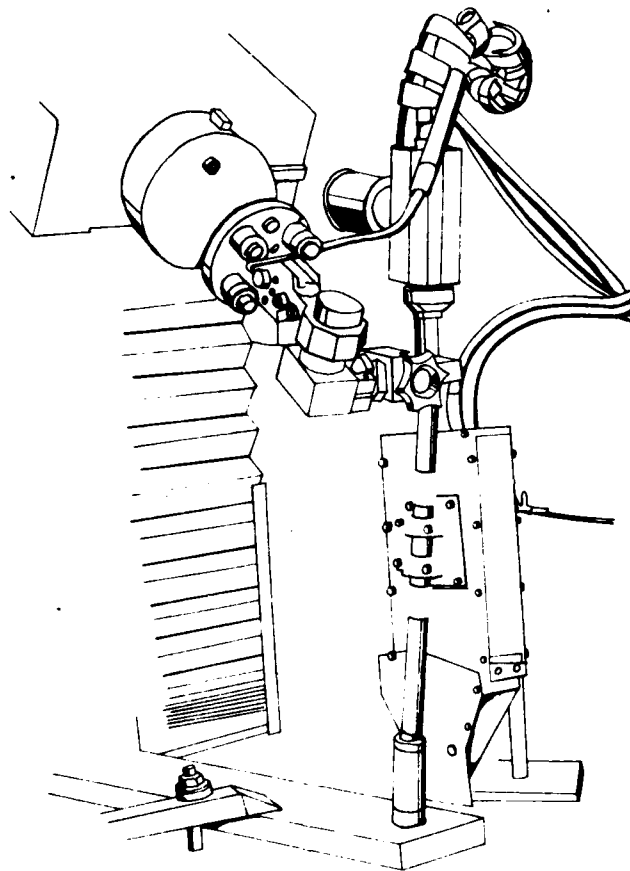

Figure 1 - Robotic Weld Seam Tracking System

#### **BENEFITS**

The development of a simple, real-time seam tracker for use in directing a robot during welding of aluminum alloys is faster and less costly than other methods. It is more cost effective to find the actual position of the weld seam rather than tighten part fabrication tolerances to ensure the seam is in the same place every time to allow use of "blind" welding robots.

**MANUFACTURING METHODS AND TECHNOLOGY  
PROJECT SUMMARY REPORT  
(RCS DRCMT-302)**

MMT Project 483 6121 titled "Robotic Welding and Weld Seam Tracking for the Bradley Fighting Vehicle (BFV), Phase I" was completed by the US Army Tank and Automotive Command in June 1984 at a cost of \$750,000.

**BACKGROUND**

Welding large products made from heavy gage metal normally requires manual control of the torch to ensure centering, high precision in parts fabrication to ensure path location, or a seam tracking system to ensure that the weld joint position is found. The simplest seam tracking system uses a mechanical probe. Unfortunately, the probe intrudes in the weld area and can be damaged. A more recent development is a robotic welding system that is nonintrusive and uses a system that senses the current between the consumable electrode and the workpiece to locate the weld groove. The problem with this system is that it only works for material with high resistivity such as steel. The electrical "noise" caused by the arc in material such as aluminum is so large that the signal-to-noise ratio is too low for detection. The solution to the seam welding problem is to combine two seemingly unrelated technologies; a through-the-arc signal to control the transverse location of the electrode and an optical range-finding sensor for proximity control.

**SUMMARY**

The primary goal of Phase I of this study was to develop a simple weld seam tracking system using commercially available components whenever possible and then to demonstrate the system's performance of robotic welding of aluminum alloys in the thicknesses common to BFV fabrication. The three main parts of the weld-seam tracking system are the robot, the optical system and the host computer. Three capabilities of robot performance were sought:

- tracking the seam
- connecting to a vision system
- welding a large variety of BFV components

The criteria established for the optical system were usefulness as a component in a seam tracking system, size, and ease of communication with the robot system through the host computer. A IBM PC was selected as the host computer based on the large variety of available software. Once the criteria for the entire system was established, the system was purchased, installed, and tested. Figure 1 depicts the system as tested.

Using weld parameters given to vendors for robot selection, tests were performed to examine the effects of changes in weld weave, cross time and weld voltage. Twelve tests were performed varying these and other parameters. The welds were inspected and the parameters giving the best results were selected. Once the weld parameters were selected, tracking tests were



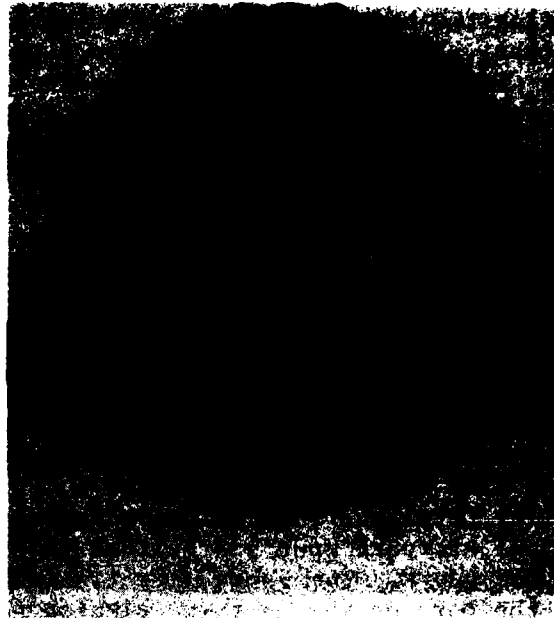

Figure 2 - Extruded Helical Gear

#### **BENEFITS**

Use of the GEARDI program can significantly reduce unit production cost of spur gears. Using reasonable production rates (above 10,000 a month), a 25 percent increase in manufacturing efficiency is projected.

#### **IMPLEMENTATION**

Eaton Corporation will use some of the project results for precision forging or extrusion of spur gears. Other companies have expressed interest in applying this technology and Battelle, the prime contractor, is investigating the possibility of starting a GEARDI users group.

#### **MORE INFORMATION**

For additional information on this project, contact Mr. D. Ostberg, AV 786-5814 or send for a copy of the final technical report "Establishment of a CAD/CAM Process for the Production of Cold Forged Gears," TR 13090, April 1985, US Army Tank-Automotive Command, ATTN: Mr. D. Ostberg, DRSTA-RCKM, Warren, MI 48397-5000.

Summary report, Jun 85, was prepared by F. Stonestreet, Manufacturing Technology Division, US Army Industrial Base Engineering Activity, Rock Island, IL 61299-7260

For the selected gears the extrusion dies were designed using GEARDI and the methodology developed in Phase I. Tool manufacturing was the next task in the project. After a suitable material was selected, GEARDI was used to develop the NC tapes needed to guide the Electrical Discharge Machining (EDM) process. The tooth cavity of the spur gear die was generated by using a wire EDM. The tooth cavity for the helical gear die was generated by using a ram-type EDM. The four previous tasks were required to prepare for the extrusion trials. A total of fifty-eight spur gears were extruded in four groups or series. After each series design changes were made as needed until thirty-seven spur gears were satisfactorily extruded in the final series. The helical gears required three series of extrusions totaling sixty-seven trials. Each series required design changes in the die. The third and final change was still not quite acceptable, but the gears could be finish machined to specifications. The next task was to test the spur and helical gears. Both the spur gears and helical gears were tested to quality levels defined by the American Gear Manufacturers Association (AGMA). AGMA Class 8 or 7 are considered acceptable standards for these types of gears. All tested spur gears were within AGMA Class 8 tolerance. The helical gears did not do as well. The inspection results of a typical extruded helical gear was at AGMA Quality Level 5. This is below the acceptable level. Figures 1 and 2 depict typical extruded spur and helical gears. The final task was finish processing the gears. The gears were finish machined in order to qualify the face and the bore of the gear in relation to the forged teeth.

The developed CAD/CAM system produced reliable results when applied to the design and forging of spur gears. The results of the spur gear trials indicated a high degree of accuracy in the ability of GEARDI to compensate for elastic deflection and bulk shrinkage of the extrusion dies. Due to unanticipated dynamic responses of the tooling during extrusion, the quality of helical gears was rather poor. Technical problems will need solutions before the helical gear can be mass produced using GEARDI.



Figure 1 - Extruded Spur Gear

**MANUFACTURING METHODS AND TECHNOLOGY  
PROJECT SUMMARY REPORT  
(RCS DRCMT-302)**

MMT Project 483 5005 titled "Establishment of a Computer-Aided Design (CAD)/ Computer-Aided Manufacturing (CAM) Process for the Production of Cold Forged Gears" was completed by the US Army Tank-Automotive Command in April 1985 at a cost of \$307,000.

**BACKGROUND**

The cold forging process is being used today to produce small gear blanks. The process has not proved feasible for larger gear blanks due to residual stresses and excessive distortion introduced during the manufacturing process. The cost is high using traditional design methods because they depend on extensive trial and error methods. Since cold forming processes offer potential savings in labor and material as well as improvement in product quality, it would be advantageous to have a method of not only designing target size gears but also designing families of gears. The use of CAD/CAM gives industry the tool to accomplish the task of designing and manufacturing cold forged gears.

**SUMMARY**

The project was broken down into two phases. Phase I is the development of a computer-aided design program for cold forged gear dies and Phase II is the computer-aided manufacturing of gears using the results of Phase I. Phase I was summarized in the December 1984 issue of Project Summary Reports. This report is a summary of the final phase, Phase II. The final product of Phase I was the CAD program called GEARDI. The objective of Phase II was to use GEARDI to design spur and helical gear dies and to subsequently manufacture these gears through an extrusion process. Phase II was divided into seven tasks: selection of gears, data transfer, die design, tool manufacture, trials, test, and finish processing. To demonstrate the process two gears, one spur and one helical not to exceed 6" in diameter, were selected. Table 1 shows some of the data that was transferred to GEARDI, the gear design program.

TABLE 1

<u>ATTRIBUTE</u>	<u>SPUR GEAR</u>	<u>HELICAL GEAR</u>
Number of teeth	16	32
Helix angle	0°	30°
Addendum	0.250"	0.100"
Dedendum	0.312"	0.125"
Root radius	1.687"	1.475"

## **MORE INFORMATION**

Additional information relating to this project can be obtained from the following technical reports: "Robotic Work Station Capable of Performing the Surface Preparation Phase in the Reconditioning Process for Aluminum Communication Shelters," DAAG38-83-MB876, November 1983 by MRC. "Automated Robotic Work Station for Painting Communication Shelters," EDEU-83/01+687, October 1983, by El Dorado Engineering Incorporated. Copies may be obtained by contacting Frank J. Estock, Tobyhanna Army Depot, AV 795-7099 or Commercial (717) 894-7099.

---

Summary report, Jun 85, was prepared by F. Stonestreet, Manufacturing Technology Division, US Army Industrial Base Engineering Activity, Rock Island, IL 61299.

The MRC robotic work station was designed to perform the surface preparation phase in the reconditioning process for aluminum communication shelters. The production target rate was 1500 shelters per year or 0.72 shelters/hour for a single shift operation. The work station is comprised of two exterior robots, one interior robot, a shelter handling system, a bead blast system, and an operator control station. The exterior robots control the vertical positioning of the shelter to accommodate reach and stroke limitations. The interior robot had to be compact enough for introduction into the shelter and yet possess sufficient reach to access all surface areas. All three robots manipulate bead blast nozzles or guns to accomplish the surface preparation. The data input for each type of shelter being worked on comes from a worksheet the operator prepares when evaluating the shelter. Each surface is programmed into the robot as a grid. This allows the operator to control the speed that the robot can bead blast a particular "grid." The only manual operations requiring human help are masking, inspection, evaluation prior to blasting, loading and unloading the shelter, entering data, opening shelter access door for the robot, making manual adjustments to bead blast system and cleaning up upon termination of cycle.

The next phase in the operation was the painting of the shelter using the El Dorado Engineering Incorporated system. Each shelter is loaded onto a track mounted dolly which moves into a spray painting booth. The dolly is positioned on a turn table and lift table assembly which orients and positions the shelter in front of two robots. The first robot paints the shelter underside and exterior walls. The second robot paints the shelter interior walls and shelter roof. The shelter exteriors may be painted a solid color, or in a camouflage pattern. An automatic paint supply system with five color changes and solvent flushing provides the multiple camouflage colors. A dry filter, side draft paint booth encloses the system and provides ventilation and pollution control. Separate control and mechanical equipment rooms are provided adjacent to the paint booth. Upon completion of the painting process, the dolly exits the booth, the shelter is unloaded, and transferred by forklift to a drying area.

The MRC system can process 0.72 shelter/hr; no cycle time is available for the painting system. The requirement is only 1500 shelters/yr, well within the capability of both systems.

#### **BENEFITS**

There is a cost savings from using the robotic shelter refinishing system of \$166/shelter. The greatest benefit, however, is the elimination of hazardous working conditions and increased efficiency.

#### **IMPLEMENTATION**

The system is to be installed at the Tobyhanna Army Depot by December 1985. The \$370,000 MMT funds have been approved for the purchase of one robotics system. Contract for installation may be awarded by September 1984.

**MANUFACTURING METHODS AND TECHNOLOGY  
PROJECT SUMMARY REPORT  
(RCS DRCHT-302)**

MMT Project G83 0002 titled "Application of Robotics to Shelter Refinishing" was completed by the Tobyhanna Army Depot, Tobyhanna, PA, in March 1984 at a cost of \$50,000.

**BACKGROUND**

Surface preparation and painting of aluminum communications shelters is presently performed manually by personnel at the Tobyhanna Army Depot. Working conditions in both operations are unacceptable because of the hazardous atmosphere generated. Operators are required to use cumbersome breathing apparatus. Surface preparation operations are very inefficient because they are done with vibrating hand sanders. Use of sand blasting methods cause damage to the shelter's skin; therefore, it cannot be used. Painting the shelter is a very time consuming operation since the camouflage pattern has to be hand traced onto the shelter. In both processes, the operators take frequent breaks due to the poor working conditions. Robots are ideal candidates for doing preparation and painting of shelters.

**SUMMARY**

This project had dual purposes: (1) to eliminate exposure of personnel to the harsh environment existing with the present manual system and (2) to increase efficiency and productivity in the shelter refinishing process. It was divided into two parts: surface preparation using robotic work stations and painting shelters using robots. One contractor (MRC) was assigned the task of developing a method of preparing the surface and another (El Dorado Engineering Incorporated) was given the task of developing painting techniques. A general layout of the preparation workstation can be seen in the figure 1 below.

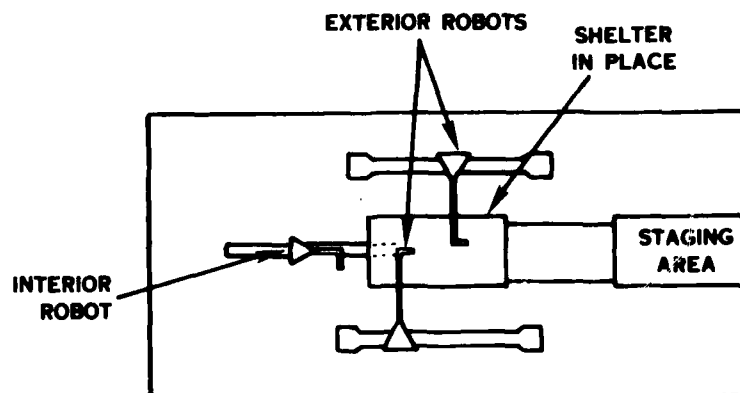
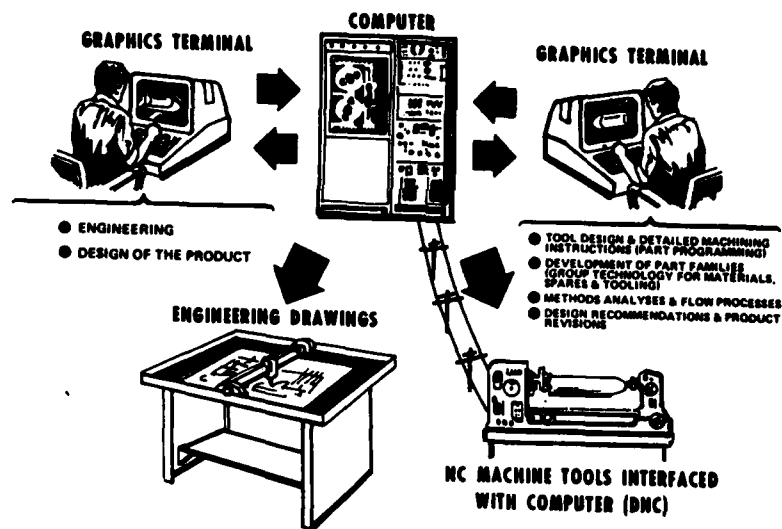

Figure 1 - Preparation Workstation

COMPUTER AIDED DESIGN/  
COMPUTER AIDED MANUFACTURING  
(CAD/CAM)



INFORMATIONAL FLOW IN A COMPUTER SYSTEM

Current fabrication methods for rocket motor insulators are costly due to extensive labor and tooling requirements. They also lack design change flexibility and suffer from long lead times. The goal of this program was to verify the cost effectiveness and versatility of a wound-elastomeric-insulator (WEI) process. A microprocessor-controlled winding machine is used to extrude green elastomer to a precisely controlled thickness and wind it directly onto the case mandrel. The motor case is then wound directly onto the insulator in the conventional manner. Testing of WEI materials resulted in the selection of an insulator which performed equal to, or superior to, the insulator presently being used. For the Pershing II program, a savings of \$4.3M will be realized on a \$950,000 implementation cost. The process may be applied to any missile system using a KEVLAR wound filament case as small as 12" to 15" in diameter.

Research and development work on rechargeable lithium/molten salt batteries has been underway for the past decade. One likely area of potential application is power sources for forklift trucks. The objective of this program was to make improvements in the manufacturing process of molten salt batteries and demonstrate them in an operational forklift. The design basis for the forklift battery was the space available on an Allis Chalmers ACE 45A Electric Rider Truck. Modifications made as a result of tests resulted in the development of a long-lived cell technology. This program provided additional confirmation of the advantages foreseen for Li-Al/FeS forklift truck batteries. These include 1) doubling or tripling of the vehicles' range, 2) decreased maintenance, 3) improved safety, 4) continuous operation via quick-charge, and 5) equivalent or improved life-cycle cost compared to the present lead-acid batteries.



681 8152

Improved Anode Straightness for Chromium Plating

ME-21

Two of the basic requirements in an anode for maximum and uniform distribution of current are straightness and mechanical rigidity. Although the anodes are fabricated as straight as possible, straightness is still a recurring problem and is reflected in the economics of reworking a badly plated cannon tube. The objective of this project was to develop an improved method of fabricating the core for the anodes used to deposit chromium to large bore gun tubes. The approach was to develop a composite anode using unidirectional, graphite filaments. The new technique provides an anode lighter in weight and sufficiently rigid to preclude bending and kinking when in use. For the 8-inch cannon and the 120mm XM256, a yearly cost savings of \$1,275,000 is projected.

781, 82 8190

Improved Blisk Impeller Cutter Life

ME-27

The expense of purchasing end mill tooling associated with machining T-700 turbine engine blisk and impeller airfoils is approximately \$2,400 per engine. An additional \$370 per engine is expended in the changing of cutters. The objective of this effort was to reduce these costs by 50 percent. Tooling material and geometry, as well as machining feeds and speeds, were investigated in order to identify parameters most significantly related to tool life. As a result of these tests, it was determined that tool life may be significantly improved by increasing primary and secondary clearance angles, and increasing the primary land width. Increasing the helix angle was found to be detrimental to tool life as was increasing the rake angle. Increasing feed rates was found to have little or no effect on tool life for certain operations.

580 4210

Jet Cutting of Energetic Materials

MU-1

Benite is made by extruding propellant material into 2.16mm diameter strands. The resulting product is dried, tied into a bundle, dried again, sawed, redried a third time, untied, sorted, inspected, redried and finally packaged. The conventional method of cutting these stick propellant strands is with carbide-tipped circular saw blades. The objective of this project was to develop a fluid jet cutting system that would reduce operating costs and improve safety. The fluid jet cutting technique uses a narrow beam of deionized water at very high pressures as the cutting tool. Performance testing of the two benite cutting operations, conventional sawing and the fluid jet cutter, concluded that there is no significant quality difference between the two. However, there is a significant reduction in drying time and a general improvement in safety by using the jet cutter. Besides the time savings, scrap is reduced by 32%.

managing everyday business. The design has flexibility as manifested by the following:

- Changes to the data base design can be accommodated without radical redesign.
- It contains and supports pathways for likely future evolution.
- It provides space for future needs.
- It can be implemented in phases.

The design to reorganize the factory is a well developed plan that has improved productivity, delivery, quality, and the working environment. The complete output of Phase II-A work is represented in a 9-volume final report.

#### **BENEFITS**

Thus far, savings of \$12 million of indirect costs have been recognized against current aviation engine contracts. As a result of the Army's planned implementation, another \$110 million in savings are projected.

Another important benefit from the effort is that the Army will be able to meet its M-1 surge requirement for the AGT 1500 engines (150 per month).

#### **IMPLEMENTATION**

Implementation cost of the floor design and the management information systems developed under the Phase II contract was to be borne by AVCO Lycoming Division (ALD) under the terms of a savings/sharing agreement negotiated between ALD and the Army. However, the savings/sharing agreement was not concluded. The Army has funded it partially at \$32 million, with an expected return of \$110 million. Presently, \$22 million has been placed on contract with the balance to be let by the end of 1985.

#### **MORE INFORMATION**

Additional information can be obtained from the AVSCOM project engineer, Nirmal Singh, AV 693-2294 or Commercial (314) 628-2294. Also, the following AVSCOM/ALD technical reports are available:

Technical Report 84-F-8, "Stratford Army Engine Plant Industrial Productivity Improvement Program" - Volumes 1 through 9, all dated 1 November 1984.

Final Report 84-F-9 "Stratford Army Engine Plant AVCO Lycoming Industrial Productivity Improvement Capacity Engineering Support Program" - Volumes 1 through 7, all dated 7 November 1984.

---

Summary report, June 85, was prepared by Rolf Anderson, Manufacturing Technology Division, US Army Industrial Base Engineering Activity, Rock Island, IL 61299-7260.

# ELECTRONICS

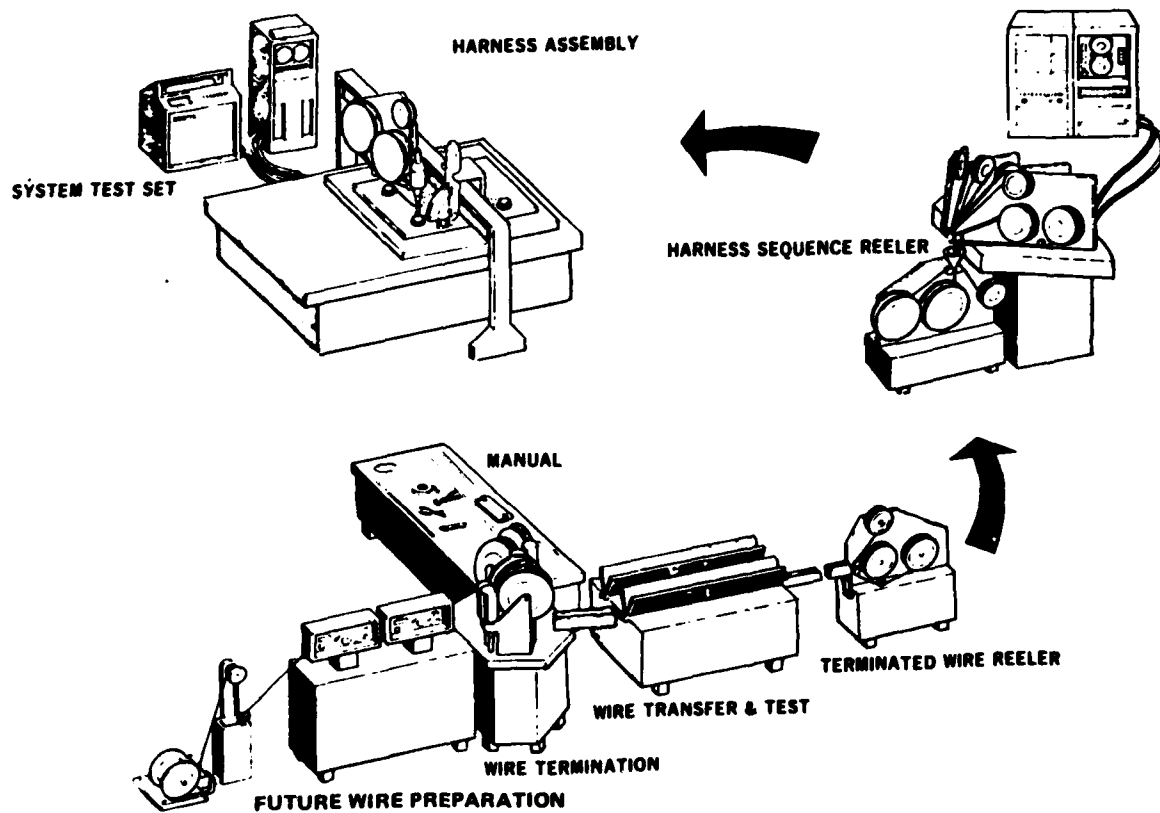

CONCEPTUAL APPROACH TO FIXING  
ELECTRICAL CONNECTORS TO CABLES

**MANUFACTURING METHODS AND TECHNOLOGY  
PROJECT SUMMARY REPORT  
(RCS DRCMT-302)**

MMT Project H80 3510 titled "Transducer Process Technology for Microwave Delay Lines" was completed by the U.S. Army Electronics Research and Development Command in May 1983 at a cost of \$509,000.

**BACKGROUND**

Microwave delay lines are integral parts of two Army fuze designs: XM735 (8-inch nuclear projectile) and XM821 (improved Hawk missile). Delay lines are coherent memories that raise jamming energy tolerance levels and offer extremely accurate distance measurement resolution. The fabrication techniques are quite common with the microelectronics industry. Zinc Oxide (ZnO) is the piezoelectric thin film transducer material for which process technology has not matured as fast as the remaining delay line technologies. This is because the requirements placed on it are ever increasingly stringent. Although delay lines have been produced since 1970, there has been little documentation of the process parameters. This has resulted in low yield, production halts, little technology transfer, and high costs.

Previous MMT Project 5 75 3061 proved that the processing technology required for this delay line was viable. MMT Project 2 77 9834 then adapted these techniques to be compatible with production pilot line requirements. This project, H 80 3510, was subsequently funded with the intent to increase the yield in the ZnO thin film transducer deposition process.

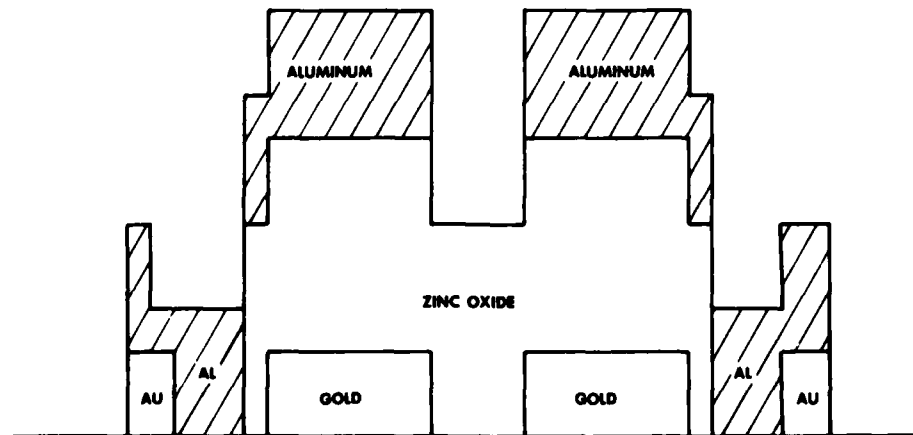

Figure 1 - ZnO Transducer Cross Section

## SUMMARY

Westinghouse Electric Corp., Defense and Electronics Center, was contracted by Harry Diamond Labs to improve specific processes in the fabrication of a 4 GHz broadband monolithic inductor-matched mosaic transducer delay line. The specific design cross-section in figure 1 shows the ZnO piezoelectric thin film transducer which is on both sides of a quartz bulk delay medium substrate. The process problems to be eliminated were a "dead" initial layer of amorphous ZnO, non-repeatable ZnO lattice orientation, ZnO contamination, gold/aluminum alloying, poor metal layer step coverage and poor packaging.

The "dead" ZnO layer phenomena was found to be due to improper orientation of the gold layer on which the ZnO is deposited. Because the ZnO lattice must be oriented in the  $\langle 0,0,2 \rangle$  direction, the gold lattice must be oriented in the  $\langle 1,1,1 \rangle$  direction for lattice match. A new gold evaporation system was purchased and set up (Consolidated Vacuum Corporation Model CVM-66) to overcome older equipment limitations. It was found that "flash" evaporation with this system produces the proper  $\langle 1,1,1 \rangle$  gold orientation repeatably.

Many RF diode sputtering runs were made with ZnO to address the ZnO contamination and orientation problem. It was found that when using a ZnO target and Ar/O<sub>2</sub> gas, the O<sub>2</sub> tends to maintain the target composition and oxidize contaminants (mainly carbon). A low O<sub>2</sub> atmosphere would leave the system contaminated, ruining the next run. The system is now preconditioned routinely by presputtering with pure O<sub>2</sub>. Another discovery of the experiments was that the ZnO lattice size is directly dependent on gas pressure and an optimal pressure was found for correct orientation of the ZnO.

There are two places where the step coverage problem could become manifest in the transducer design. One is where the 1800 angstrom thick aluminum steps a 4500 angstrom thick gold layer and the other is where a 1200 angstrom thick gold layer steps a 10,000 angstrom thick gold layer. The concern stems from possible shadowing of the thin metal path leading to a discontinuity. This problem was solved by increasing the thickness of the thin layer to the same as the ZnO layer. It is kept off of the active area to prevent mass loading.

The delay line design uses an aluminum top layer transducer element contact to a gold bottom layer transducer element contact. This gives the possibility of forming a variety of alloys at the interconnect which are notorious in the semiconductor industry for causing failures. The alloys such as the "purple plague" have very high resistance. To circumvent this, a chromium barrier layer deposition process was added between the aluminum and gold layers. No metal migration was found in the reliability tests.

A package feedthrough RF leakage problem was found to be due to leakage over and around the quartz substrate. In order to ground this leakage, a conductive "fuzz ball" of #32 wire was used to ground all four sides of the substrate with conductive polyimide. It contacts the lid and seals the radiation path.

The final technical report contains a complete description of the required delay line processing in Appendix A. Testing and inspection procedures are also described.

#### **BENEFITS**

The use of the new processing has increased the packaged device yield to 50 percent. A prescribed process description is available for transfer to other delay line manufacturers.

#### **IMPLEMENTATION**

The results of this project were self-implementing at Westinghouse thereby creating a second source for these delay lines. The delay lines are used in the Airborne Self Protection Jammer (ASPJ) which went into production in 1983.

#### **MORE INFORMATION**

Additional information is available by contacting Mr. Stuart Lieberman, Harry Diamond Labs, AV 290-3110 or Commercial (202) 394-1551. The contract number was DAAK21-80-C-0059.

---

Summary report, Jun 85, was prepared by Dan Richardson, Manufacturing Technology Division, US Army Industrial Base Engineering Activity, Rock Island, IL 61299-7260

**MANUFACTURING METHODS AND TECHNOLOGY**  
**PROJECT SUMMARY REPORT**  
**(RCS DRGNT-302)**

MMT Project 084 5071-57 titled "General Purpose Bit-Slice Minicomputer Interface" was completed by the US Army Test and Evaluation Command in October 1983 at a cost of \$20,000.

**BACKGROUND**

During the past few years the US Army Materiel Test and Evaluation Directorate (ARMTE) has utilized bit-slice technology in computer instrumentation support of Test and Evaluation Command (TECOM) test projects. To satisfy the instrumentation requirements of each project, a unique bit-slice processor was designed for use on each project. Experience has suggested that a general purpose computer interface could be designed that could be used on any project. Only changes to the bit-slice microprograms would be required to tailor the interface to the project.

**SUMMARY**

ARMTE conducted a study to determine their bit-slice minicomputer interface future requirements in order to determine the features essential to development of a general purpose computer interface. Among the many facts established by the study were: data requirements of a parallel nature, interface requires high speed decision-making abilities, and the interface must be versatile enough to permit field changes. The study resulted in some rethinking by ARMTE's design engineers about controller design. Bit-slice is a universal building block where the user has full control of the amount of processing and control that is required. Users have the flexibility to create their own customized instruction set without any hardware redesign other than a simple firmware update and a one-to-one replacement of control store memory. As the complexity of operations and the number of control signals increase (see figure 1), bit-slice devices become the preferred approach.

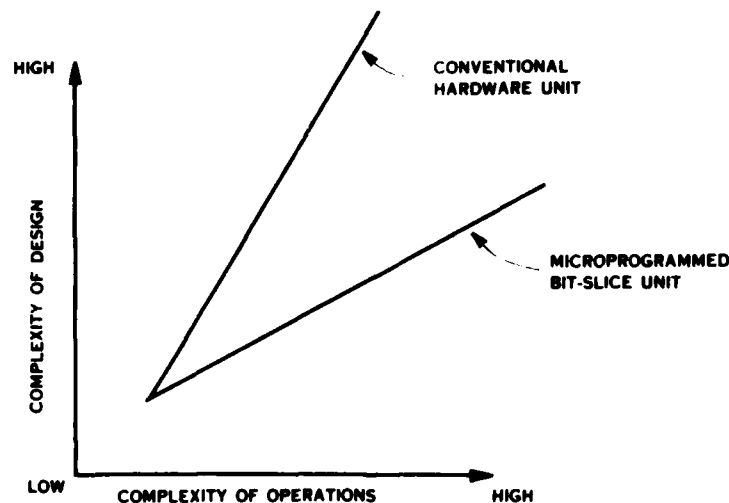

Figure 1 - Complexity of Operations vs Design

The heart of the Bit Slice Interface (BSI) is the microprogrammable controller designed around the Advanced Micro Devices 2900 Series bit-slice architecture. The BSI is designed so that any system requiring a minicomputer interface can use the BSI. The BSI utilizes both an interrupt and direct memory access (DMA) scheme. A multiple Data/Control buffer algorithm allows communication between the BSI's RAM to be loaded via the mini-computer. This arrangement allows the RAM's contents to be edited, saved and executed via the minicomputer generated software. Using the BSI the designer is provided with the following:

- o Quick instrumentation response
- o Economical Operation
- o Procurement lead time reduction
- o Reduced technical expertise
- o Decreased design time
- o Higher System reliability/maintainability
- o Self-test features
- o Simple field changes

Application of the BSI concept will help designers reduce engineering time spent on custom designing.

#### **BENEFITS**

Dollar savings will be realized by not requiring \$10,000 engineering efforts to produce a specialized bit-slice computer interface for each project. Instrumentation reliability will be increased and more projects can be supported with existing instrumentation.

#### **IMPLEMENTATION**

The results of this study will be applied to an existing bit-slice microprocessor which will be modified to function as a general purpose computer interface for a feasibility demonstration.

#### **MORE INFORMATION**

Additional information may be obtained from Mr. Larry W. Alejo, AV 258-4808 or Commercial (505) 678-4808 or obtain a copy of the final technical report, "General Purpose Bit-slice Minicomputer Interface," RDTE IT 665702D625, October 1983, from the Army Material Test and Evaluation Directorate, US Army White Sands Missile Range, New Mexico 88002.

Summary report, Jun 85, was prepared by F. Stonestreet, Manufacturing Technology Division, US Army Industrial Base Engineering Activity, Rock Island, IL 61299



**MANUFACTURING METHODS AND TECHNOLOGY  
PROJECT SUMMARY REPORT  
(RCS DRCMT-302)**

MMT Project E82 3796 titled "Combat Vehicle Deperming Production Facility" was completed by the US Army Belvoir Research and Development Center in September 1984 at a cost of \$916,000.

**BACKGROUND**

Present design and fabrication techniques associated with armored vehicle production results in a significant magnetic signature for the vehicle. This magnetic signature can be used to fuze a land mine. Field tests using operational facilities in Britain and Germany confirmed that a tank can be degaussed such that the vehicles magnetic signature is virtually eliminated. This series of projects, when completed, will result in a prototype facility for degaussing armored vehicles. The follow-on systems will be installed in factories and field depots.

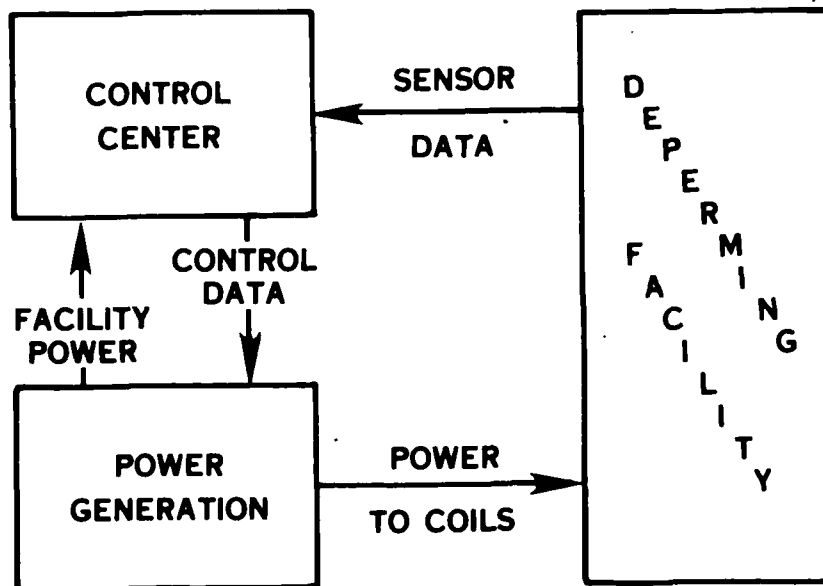

Figure 1 - Deperming Facility Schematic

**SUMMARY**

This is the first FY of a three-year effort. The purpose of this phase was to establish the design criteria and performance specifications for a vehicle mobile deperming facility. The facility will provide the ability to measure the magnetic state of the vehicle and deperm the vehicle. Major components of the system include the deperming structure, a power system and a control shelter as shown in figure 1. The deperming structure will contain the deperming coils into which the vehicles will be driven and then aligned over a set of sensors and the coils. Under the structure will be an array of magnetic field measuring sensors and to the side will be a triaxial magnetometer. A gaussmeter will be placed inside the vehicle for experimental purposes, to monitor the internal magnetic field during the deperming process.

The power source will be diesel engine/generator sets and associated power converters to provide the plus and minus electrical currents to the deperming coils and to provide AC power to the control shelter. These units will be located remotely from the deperming structure to reduce the possibility of interactions between the units.

The control shelter will contain a computer to maintain system control, monitor the sensors and provide system performance statistics. Data from the sensors will be monitored to determine the actual number of cycles and the effectiveness of the system in reducing the vehicle signature. These signals in turn provide the basis for control of the current in the degaussing coils. The profile of current flow as a function of time will be readily alterable such that an optimum current-time relationship can be determined for each vehicle or class of vehicle.

The next phase of this effort will initiate fabrication of the individual components based on the design criteria developed during this phase. The final phase (third) will provide the system integration, technical data package, and testing results.

#### **BENEFITS**

This project has provided the design for a degaussing system to reduce the magnetic signature of combat vehicles.

#### **IMPLEMENTATION**

The implementation of this project will occur after completion of the final two follow-on projects.

#### **MORE INFORMATION**

Additional information may be obtained Ms. B. Briggs, Belvoir R&D Center, AV 354-6979. A final report titled "Vehicle Mobile Deperming Facility," contract DAAK70-82-C-0241, is also available.

---

Summary report, Jun 85, was prepared by Hal Weidner, Manufacturing Technology Division, US Army Industrial Base Engineering Activity, Rock Island, IL 61299-7260.

# INSPECTION AND TEST

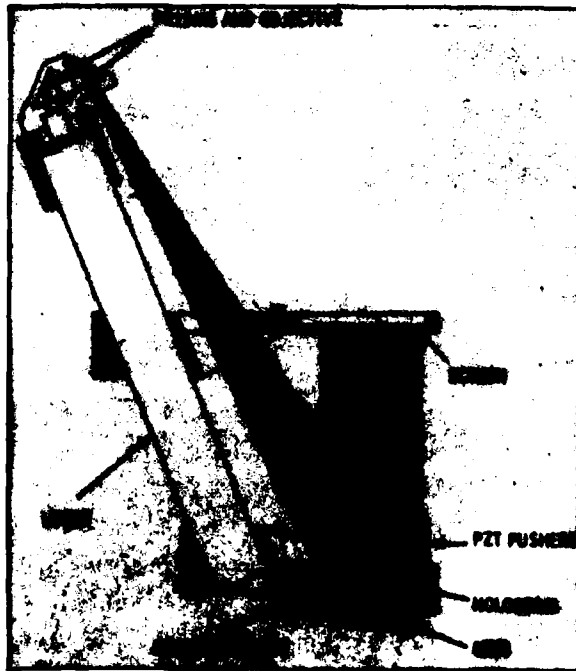

OPTICAL HOLOGRAPHIC TEST EQUIPMENT

**MANUFACTURING METHODS AND TECHNOLOGY  
PROJECT SUMMARY REPORT  
(RCS DRGMT-302)**

MMT Project O 5071-71 titled "Improved Copper Crusher Pressure Gages" was completed by the US Army Test and Evaluation Command in May 1984 at a cost of \$80,000.

**BACKGROUND**

Copper crusher pressure gages are instruments used to measure the peak chamber pressure in guns. Figure 1 is a simplified representation of a copper crusher pressure gage. When the gage is subjected to an increase in pressure, the crusher is pressed between the piston and anvil and plastically deformed in proportion to the applied pressure. The deformed crusher is measured to determine its final height. Calibration tables list the pressure that corresponds to the final height. For 20 years the M11 Copper Crusher Gage has been the standard US Army crusher gage for high pressure measurement. Advances in artillery weapons and ammunitions in recent years has created a concern that the M11 does not provide the precision needed. In 1977 this concern became reality during NATO firing tests held at Meppur, Germany. The M11 gage was entered during the 1977 trials and qualified at high pressures and ambient temperatures. At high temperatures and low temperatures the M11 gage did not qualify. It was apparent that a program was needed to improve the performance of the M11 gage.

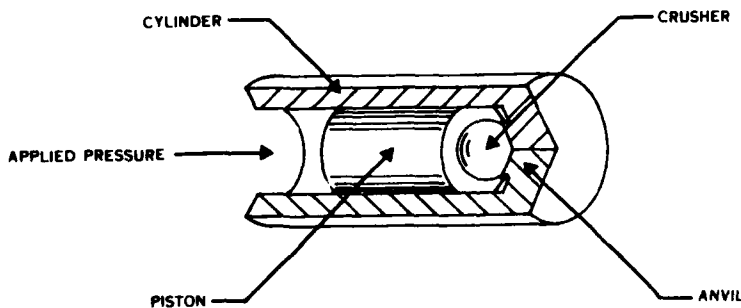

Figure 1 - Copper Crusher Pressure Gage

**SUMMARY**

To improve the precision of the M11 Copper Crusher Pressure Gage, it was necessary to first determine the mechanism responsible for the lack of precision. A stress analysis using finite elements was performed to simulate the forces acting on crusher gage during testing. The stress analysis revealed

that external pressure on the gage body caused the cylinder to constrict around the piston and hinder its movement. The first modification made involved deepening the trepan. The trepan has the effect of isolating a portion of the cylinder from the rest of the gage body. Included in the modification was the use of a shorter piston. A stress analysis indicated that the piston would operate freely at pressures up to 8,300 bars. Based on the stress analysis a modified gage was designed and fabricated for testing.

The first phase of testing was designed to insure that the modifications had not changed the basic operation of the M11 gage. To optimize control of the tests, a Hydrodynamic Pressure Generator was used at six pressure levels. There was no significant difference between the standard M11 and the modified M11 at pressure levels below 3,000 bars. Tests performed at the 3,450 bar level indicated that there were some changes due to the modification. Testing at higher pressures required actual test firing in the field. The weapons used were expected to deliver chamber pressure in excess of 4,000 bars. Of the 26 modified gages tested, 18 were irreparably damaged after exposure to just one round. Damage was caused by propellant gases leaking by the piston. In an attempt to alleviate the problem, it was decided to substitute the standard M11 piston for the modified shortened piston. At about the same time as these decisions were being made, the Combat Systems Testing Activity (CSTA) acquired a new pressure generator capable of pressures up to 8,300 bars. Tests were performed on the newly modified gages using the Dynamic Pressure Generating System (DPGS). The results indicated that the longer piston provided adequate resistance to leakage.

An optimization study determined that the ideal piston length to maximize leakage resistance should be 9.5 mm, longer than the original modified piston but shorter than the standard piston. The study also indicated that piston body modifications were needed. Stress analysis of the modification indicated that the piston would move freely over the full operation range of pressures. Comparative testing using the DPGS was performed on the standard M11 gage, the first modification and the second modification. The results indicated that both body modifications with the standard piston gave the best results. The 9.5 mm piston prevented leakage but gave inconsistent pressure indications. The next step was to compare the two modifications under actual field conditions. The original purpose of the study was to improve precision at extreme temperatures. Therefore, the comparison tests were performed at  $-45^{\circ}\text{C}$ . The first modification consistently out-performed the second modification. Comprehensive tests were done using the first modification of the M11 crusher gage. The modified gage is still unreliable at high temperatures ( $260^{\circ}\text{C}$ ), but it out-performs the standard M11 at ambient temperatures and at  $-40^{\circ}\text{C}$ .

## **BENEFITS**

This project greatly improved the ability to reliably measure pressure at ambient and lower temperatures. Failure to obtain correct pressure measurements during acceptance testing of weapons and ammunition can result in serious problems. Examples are loss of lives and millions of dollars in manufacturing rework.

#### **IMPLEMENTATION**

Limited quantities of the modified gage will be procured. The gages will be made available to TECOM Proving Grounds for low temperature testing.

#### **MORE INFORMATION**

For more information contact Arlen L. Weddle, Material Testing Directorate, ATTN: STEAP-MT-GP-M, Aberdeen Proving Grounds, MD 21005 or obtain a copy of the final technical report "Improved Copper Crusher Pressure Gages," May 1984, report number APG-MT-6014.

Summary report, Jun 85, was prepared by F. Stonestreet, Manufacturing Technology Div., US Army Industrial Base Engineering Activity, Rock Island, IL 61299-7260

**MANUFACTURING METHODS AND TECHNOLOGY  
PROJECT SUMMARY REPORT  
(RCS DRCMT-302)**

MMT Project 082 5071-100 titled "Automated Particle Contamination Measurement in Hydraulic Fluids" was completed by the US Test and Evaluation Command in September 1984 at a cost of \$6,300.

**BACKGROUND**

As a part of the routine analysis of oil samples from vehicles, hydraulic fluid samples are tested for particle contamination. Each analysis requires 355 ml (12 oz) of hydraulic fluid for a particle count analysis on the automatic particle counter. In many cases it is not possible to get the required 355 ml sample. Procedures for determining the contamination in small samples were not available. It was decided that an investigation should be undertaken to develop procedures for determining particles in small quantities of fluid.

**SUMMARY**

Two methods of counting particles in hydraulic fluid were investigated:

- dilution with a fluid of known contamination
- recycling the fluid

To insure that unwanted contamination does not enter into the tests, a method was developed to properly clean the glassware. The procedure developed involved two solvents, hot water, detergent, distilled water and oven drying. The method of particle counting via dilution required finding a compatible fluid as the diluent. Tests were performed using particle counters and it was found that the flow rate was a highly critical factor in particle count determinations. The flow rate tests led to the decision that, whenever possible, the diluent and the contaminated hydraulic fluid should be of the same type. The next step was to determine the most accurate procedures for dilution and recycling. To determine the most accurate method of dilution the first step was to develop a method to clean the diluting hydraulic fluid. The method developed involved centrifuging and deaerating the fluid. To simulate actual field conditions, all work was carried out in normal environmental conditions, i.e., with dust and other particles in the air. Each time the diluting fluid was transferred, transfer time was the only factor considered in preventing dust contamination. The next step was to add a small amount of the contaminated hydraulic fluid to the clean diluent. The resulting fluid is thoroughly mixed and run through a particle counter.

To determine the most accurate method of recycling, some hydraulic fluid was "run" through the particle counter, then centrifuged, and again run through the particle counter. The particle count changed drastically as expected. The next step was to transfer the fluid to a clean beaker and then run the particle count again. The count increased almost to the original level. Different methods of transferring the fluid through the particle counter drain tube were tried (within the constraint of field conditions) and

**MANUFACTURING METHODS AND TECHNOLOGY  
PROJECT SUMMARY REPORT  
(RCS DRCMT-302)**

MMT Project 383 1086 titled "Cobalt Replacement in Maraging Steel for Rocket Motor Components" was completed by US Army Missile Command in December 1984 at a cost of \$500,000.

**BACKGROUND**

Current high performance rocket motor components utilize maraging steel in large quantities. Maraging steel is predominately a nickel-alloy. However, it has historically been heavily dependent on cobalt for its physical properties. Most compositions contain about nine percent cobalt. This element is becoming increasingly difficult and frequently expensive to obtain because the United States must import almost 100 percent of its requirements from politically sensitive areas of the world.

In order to overcome the cobalt dependency in rocket motor components, a three-phase effort was initiated to establish manufacturing methodology for producing rocket components using a new cobalt-free maraging steel designated "co-free."

The first and second phases of this effort entailed the fabrication of rocket motor cases made with cobalt-free maraging steel. Also, the effects of various forging and anneal temperatures on the mechanical properties of the material were evaluated relative to forging, drawing, shear forming, and welding operations. Manufacturing characteristics and mechanical properties were compared to those obtained with the cobalt material containing 18 Ni 300 grade maraging steel, which is currently being used in rocket motor cases.

**SUMMARY**

The objective of this last phase of the three-phase effort was to produce and test scaled-up solid rocket motor case assemblies made from co-free maraging steel. Detailed manufacturing procedures were to be prepared as well.

Two different forms of raw material were used: 8" round corner square (RCS) billet mullets or slugs for forging, and extruded pipe mullets. The procedures developed for both assemblies are basically the same except for the



**MANUFACTURING METHODS AND TECHNOLOGY  
PROJECT SUMMARY REPORT  
(RCS DRGMT-302)**

MMT Project 182 7366 titled "Spiral Self-Acting Seals" was completed by the US Army Aviation Systems Command in March 1984 at a cost of \$90,000.

**BACKGROUND**

A need exists for a zero-leakage air-to-air seal which can withstand the high temperatures, pressures, and rubbing velocities inherent in the Army's current man-rated engines. The labyrinth seals presently used exhibit a definable leakage rate even when new. This leakage rate worsens with seal wear and results in significant power loss and decreased engine life.

**SUMMARY**

An RFP was prepared for use in a competitive procurement for the spiral self-acting seal. A re-evaluation of the cost savings potential indicated that sufficient production volumes would not exist by the time project results would be ready for implementation. Consequently, this project was terminated at the request of the T-700 Program Manager.

**BENEFITS**

None.

**IMPLEMENTATION**

None.

**ADDITIONAL INFORMATION**

Additional information may be obtained by contacting Mr. William Brand, AVSCOM, AV 693-3079 or Commercial (314) 263-3079.

---

Summary report, June 85, was prepared by Alan Peltz, Manufacturing Technology Division, US Army Industrial Base Engineering Activity, Rock Island, IL 61299-7260.

Detroit Diesel Allison has completed all specimen testing of cast-to-size test bars and impeller sections. The results have shown tensile strength of the Ti6246 castings to be comparable to the forged product. Also, fatigue properties are comparable to forged Ti64. An overspeed spin test to 139 percent design speed was successfully completed with a cast impeller. A detailed analysis of the processes developed will be reported in the final year of this effort.

#### **BENEFITS**

This is the fourth year of a 5-year program. Anticipated benefits upon the successful completion of this program will enable the Army to produce titanium centrifugal compressor impellers at reduced cost compared to forged impellers. In addition, the results of this program will have direct application to other titanium centrifugal compressors.

#### **IMPLEMENTATION**

After completion of this program, an Engineering Change Proposal will be prepared for introduction of cast titanium impellers into T62T-40 production. Detroit Diesel Allison will introduce cast impellers in the GMA500 during development testing to qualify the parts prior to initial production.

#### **MORE INFORMATION**

Additional information covering this project may be obtained from Mr. M. Galvas, Applied Technology Laboratory, US Army Research and Technology Laboratories, AVRADCOM, AV 927-2771 or Commercial (804) 878-2771.

---

Summary report, June 85, was prepared by Wally Graham, Manufacturing Technology Division, US Army Industrial Base Engineering Activity, Rock Island, IL 61299-7260.

**MANUFACTURING METHODS AND TECHNOLOGY  
PROJECT SUMMARY REPORT  
(RCS DRCMT-302)**

MMT Project 181 7285 titled "Cast Titanium Compressor Impellers" was completed in August 1984 by the US Army Aviation Research and Development Command at a cost of \$128,000.

**BACKGROUND**

Current titanium compressor impellers are produced by machining the flowpath and blade surfaces from an oversized forging. This results in a substantial loss of material and expensive machining operations. Typically, as shown in figure 1, about 75 percent of the initial forging is machined away. Machining operations generally constitute about 66 percent of the total impeller cost. Investment casting to near-net shape will improve material utilization and reduce machining operations. In addition, hot isostatic pressing and heat treatment of the castings will improve the mechanical and fatigue properties to a level attractive for dynamic applications.

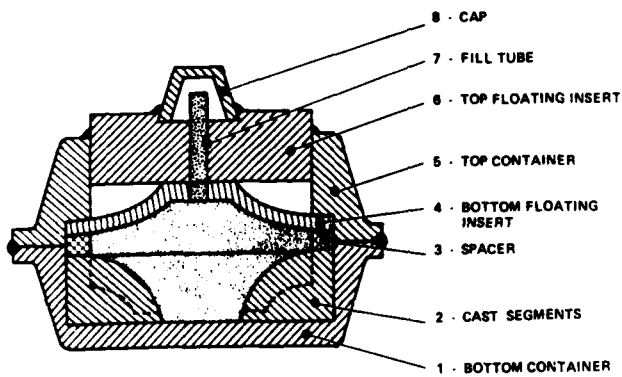

Figure 1 - Compressor Impeller

**SUMMARY**

The major objective of this program was to develop and demonstrate a pilot production process for investment casting titanium centrifugal compressor impellers to near-net shape. The compressor impellers were produced and tested to completely evaluate the economic advantages of the selected casting technique and processing against life cycle costs of the conventional forged and machined compressor impeller.

# METALS



**DETAIL**

- 1
- 2
- 3
- 4
- 5
- 6
- 7
- 8

**MATERIAL SHAPE**

- BAR OR TUBING AND PLATE
- INVESTMENT CAST SEGMENTS WELDED INTO A RING
- PLATE OR TUBING
- PLATE
- BAR OR TUBING
- BAR OR PLATE
- TUBING
- BAR

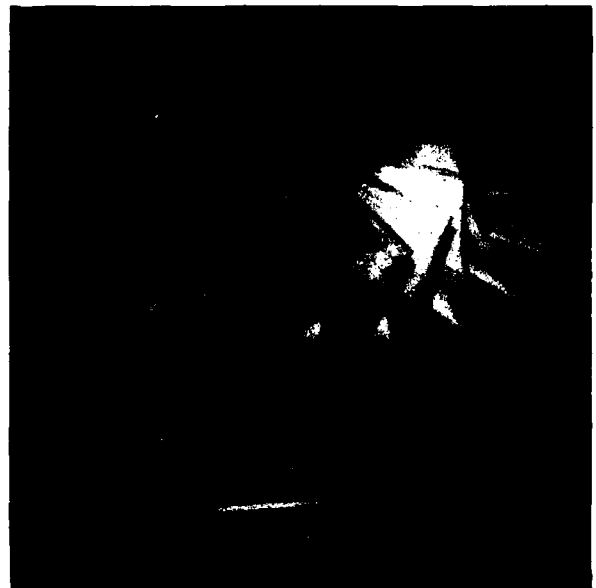

FLUID DIE SCHEMATIC AND RESULTING IMPELLER

## **BENEFITS**

The primary benefit realized by the Army from this project was identification of the areas of opportunities for automation. Also, a prototype gun barrel laser straightness measuring concept was established. Automated land, groove and diametral gun barrel inspection equipment has been identified for use in a production environment with continuous feedback to the process operator.

## **IMPLEMENTATION**

The results of this project will be used for Phases II-IV of this effort to automate the inspection and process control of small caliber weapons part manufacturing.

## **MORE INFORMATION**

A technical report is available, titled "Improve Inspection Procedures and Process Control for Modernized Small Arms Gun Barrel Manufacture," dated September 1983, SACO Defense System Division, Maremont Corporation, SACO, ME. For additional information, contact F. Baker, AMCCOM, ARDC, AV 880-5698 or Commercial (201) 724-5698.

Summary report, Jun 85, was prepared by D. Brim, Manufacturing Technology Div., US Army Industrial Base Engineering Activity, Rock Island, IL 61299.

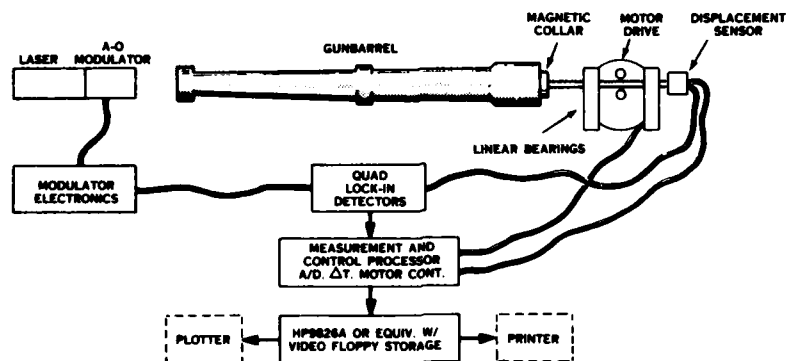

Figure 1 - Gun Barrel Laser Straightness Measuring Concept

monitors its output, converts it to actual dimensional measurements from bore centerline established by the laser, and correlates it to axial location inputs from a linear displacement transducer recording target location. The processed data is compared to present limits entered in the computer. If the barrel is out of tolerance, the computer will identify the axial location, radially orient the barrel, and command the press to apply a specific load to straighten the barrel. This inspection, analysis, and straightening procedure will continue automatically until the barrel is radially within tolerance of all preselected axial locations.

Task III - In-Plant Survey of Inspection Techniques and Process Controls was conducted to identify viable candidates for feedback controlled processes. This survey identified the following candidates for automatic process inspection and feedback control.

- o Inspection and automatic process control in machining gun barrel outside diameters and geometry.
- o Automation of chamber inspection.
- o Automation of chrome/plating inspection, and fixturing processes.
- o Automation of the M2, caliber .50, gun barrel tube, liner, and retainer assembly processes.

In summary, this project has provided a first look at the present SACO defense systems inspection and process control capabilities. The areas with the greatest opportunities for automation have been identified.

**MANUFACTURING METHODS AND TECHNOLOGY  
PROJECT SUMMARY REPORT  
(RCS DRGMT-302)**

MMT Project 682 8370 titled "Automatic Inspection and Process Control of Weapons Parts Manufacturing" was completed in February 1984 by the US Army Armament, Munitions and Chemical Command, Armament Research and Development Center, at a cost of \$193,000.

**BACKGROUND**

The Army is in the process of modernizing the small caliber gun barrel production line at the Maremont Corporation's SACO Systems Division plant, SACO, ME. The current inspection techniques and process controls used in the manufacture of small caliber gun barrels are 1940-1950 vintage. The inspection techniques and controls for chamber contours, bore diameter, rifling diameter, concentricity, and flaw detection are labor intensive and are currently limiting the production rate of the recently installed rotary forge. For example, the chamber measurement now requires the use of 20-24 separate gaging operations. These antiquated inspection techniques and process controls require updating to be able to support a modernized small caliber gun barrel production line.

**SUMMARY**

This effort was initiated to modernize the Army's small caliber gun barrel manufacturing inspection techniques and process controls. This project, Phase I of a IV-phased effort, included the following tasks:

Task I-Land, Groove, and Diametral Gun Barrel Inspection Equipment Evaluation consisted of accessing the efficiency and effectiveness of state-of-the-art equipment using air or electronic probes. This evaluation included determining whether this equipment could be used in an automated production environment for continuous feedback to the process operator. It was concluded that the accuracies, repeatability and inspection time for the state-of-the-art equipment evaluated were comparable and performed within the tolerances required to inspect the gun barrels. However, it should be noted that electronic gaging other than that associated with mechanical contact type air and electronic probes was not evaluated. Other measurement means such as capacitance, eddy current, inductance, and optical should be considered and evaluated prior to selecting the bore measurement techniques.

Task II - Gun Barrel Laser Straightness Measuring Concept Evaluation was to determine which competing conceptual prototype demonstration mode was the most efficient and effective. The basic operation theory of these competing systems (figure 1) included supporting the barrel at each end and directing a laser beam through the bore to a target which can be traversed through the bore from the opposite end. The laser beam creates a straight line reference. The target vehicle tracks the bore diameter and changes output when the laser light spot illuminates a different location within the circumference of the target. As the target is moved through the bore, the computer

pneumatic activating system. The LVDT instrumentation system coordinates the movements of the 16 LVDT's. A HP 85 calculator is used to analyze, display and printout all data collected by the LVDT's and ultrasonic transducers. The heart of the automated gaging system is a Z80 microprocessor that is in the Microcontroller console. The Z80 controls everything from LVDT's to the air valves. The automated inspection system gives the user 100 percent inspection capability of the complete projectile body. The savings in time and money combined with the increase in quality makes the system ideal for Army use.

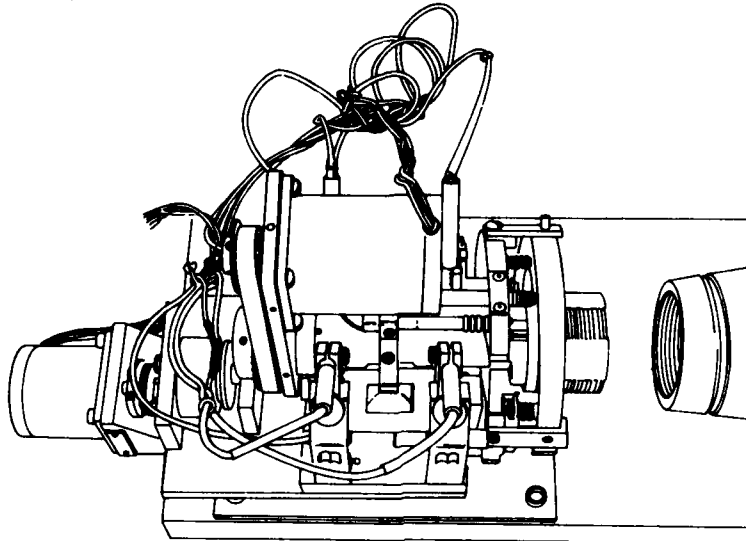

Figure 1 - Automated Gaging System

#### **BENEFITS**

The automated gaging system is cheaper, faster, and more accurate. The present manual methods cost an average of 20¢/body overall. This is reduced to 10¢/body with an automated system. In addition, the latter system will permit 100 percent inspection versus only 20 percent under the manual system.

#### **IMPLEMENTATION**

Upon acceptance of the automated projectile gage, the system will be implemented at the Louisiana Army Ammunition Plant, the Mississippi Army Ammunition Plant, Norris Industries and the American International Manufacturing Corporation.

#### **MORE INFORMATION**

For more information on the project contact Robert L. Copeland, AV 933-0111, ext. 426, Commercial (714) 620-0426 or obtain a copy of the final technical report "MMT - Automated Gaging for Medium Caliber Projectile Bodies (CAM)," February 1985, from the Department of the Navy, Gage and Standards Center, Naval Weapons Station, Seal Beach, Pomona Site, PO Box 2426, Pomona, California 91769.

Summary report, Jun 85, was prepared by F. Stonestreet, Manufacturing Technology Div., US Army Industrial Base Engineering Activity, Rock Island, IL 61299-7260



**MANUFACTURING METHODS AND TECHNOLOGY  
PROJECT SUMMARY REPORT  
(RCS DRCMT-302)**

MMT Project 581 1907 titled "Automated Gaging for Medium Caliber Projectile Bodies" was completed by the US Army Armament, Material and Chemical Command in December 1984 at a project cost of \$539,600.

**BACKGROUND**

The number of configuration requirements for medium caliber munitions for US military and foreign military sales are many and varied. Each of these configurations require specific gage designs, adequate copies of each design, and maintenance procedures to support the weapons system throughout its life cycle. The acceptance inspection system currently in use today consists of primarily single attribute type inspection equipment which is labor intensive. Current inspection requirements for medium caliber ammunition involve inspection of such areas as internal nose thread, pitch, diameter, internal and external runout. These are only five of many inspection requirements. An appreciable amount of time and money could be saved by developing an automated gaging system. The AMCCOM sponsored work was performed by the Navy's Gage and Standards Center.

**SUMMARY**

The purpose of this project was to design an automated acceptance inspection gaging system for medium caliber projectile bodies. The development of the Automated Gaging System can be divided into three basic phases. The first phase was a feasibility study to determine if developing an automated system was possible. The second phase involved building a prototype system capable of carrying out data deduction of 155mm projectile fuse thread diameter, runout and bourrelet diameter. The third and final phase was to build an automated inspection gage that would supplement 20 standard gages now in use. The developed system is composed of a holding fixture (roller "V" blocks), an ultrasonic gaging system, an expandable thread plug gage, a projectile rotating drive system, pneumatic activation system, a Linear Variable Differential Transformer (LVDT) instrumentation system, an HP 85 calculator and a microcontroller enclosure. The final gage built is set up to inspect 5"/54 caliber projectile bodies.

The following is a brief description of the Automated Gaging System (see figure 1). The holding fixture is designed to position the projectile body with respect to the LVDT's. The LVDT's are used to determine the bourrelet diameter which define datum A, the theoretical centerline of the projectile body. The ultrasonic gaging system is highly sophisticated unit that features 8-5MHz transducers, an 8-channel multiplexer and a coupling fluid recirculation system. To measure the pitch diameter of the fuze threads requires an expandable thread plug gage. Five LVDTs are used to collect the required data. To ensure complete inspection of the projectile body, a projectile rotating drive system is incorporated into the system. A microprocessor controlled air valve is activated at the proper time so that air cylinders will bring the LVDT tips to the projectile body. This is the

With the actuation of the START switch, the proper valves were actuated and the challenge flow (without agent) began. Once temperature, humidity, and flow were within testing limits, the test mode was entered. Agent injection began and the system remained in this mode until the filter experienced a "break," at which time the filter break parameters were printed and the PURGE mode was entered. In the PURGE mode, flow (without agent injection) continued, and when the agent concentration dropped below preprogrammed limits, the system returned to the IDLE state. This completed a single challenge cycle.

The contractor, Systems and Applied Sciences Corporation, successfully developed and demonstrated the prototype automatic multiple filter life tester. The system functioned well with the agent simulant, dimethylmethylphosphonate (DMMP), and several test filters were challenged and saturated within the contract requirements.

### **BENEFITS**

An automated multiple filter life tester was developed which is more accurate, reliable, and easier to operate than previous testers. This test equipment will be applicable throughout the life cycle of gas filters and will result in improved test results and increased production rates.

### **IMPLEMENTATION**

The proposed equipment will be added to the item specifications by engineering change proposals for use in acceptance testing. The test equipment will be procured through the PS & ER program for use by the Government in the performance of acceptance testing operations.

### **MORE INFORMATION**

Additional information on this project is available from Mr. G. Lattin, CRDC (Aberdeen Proving Ground, MD), AV 584-3510 or Commercial (301) 671-3510.

---

Summary report, June 85, was prepared by Pete Martin, Manufacturing Technology Division, US Army Industrial Base Engineering Activity, Rock Island, IL 61299-7260.

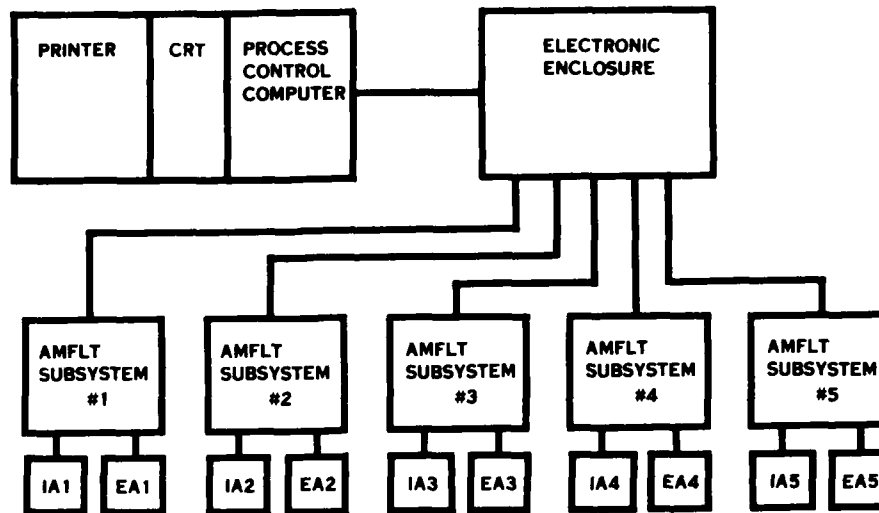

IA - INFLUENT ANALYZER  
EA - EFFLUENT ANALYZER

Figure 1 - Schematic Diagram of Modular Testing System

The gas supply source was composed of an agent container and a generator section. The liquid agent was fed to the generator by air pressure. In the generator, the liquid agent was dispersed into small particles by means of a piezoelectric crystal.

The filter/canister chamber is a separate unit in which the canister can be mounted and locked into place. A series of microswitches can be actuated to sense the type of canister installed. (M10A1, M11, M13A2).

To measure both the influent and effluent, three different analyzers were used. They were a hydrocarbon analyzer, halide detector, and FPD phosphorus analyzer.

A process control computer was used between the operator and the testing system and to gather, print, and store test data.

The following operation sequence was performed to test (challenge) a filter/canister:

Initially, the filter was installed onto the filter housing and the chamber door closed. If the operator wanted to observe specific test parameters during the challenge sequence, the computer was set to the desired parameter. The FILTER TYPE was set to agree with the type of filter installed. The MODE was set for either the intermittent (INT) or continuous (CONT) challenge flow. If the intermittent mode was selected, the BREATH RATE control was set for the desired breath rate.

**MANUFACTURING METHODS AND TECHNOLOGY  
PROJECT SUMMARY REPORT  
(RCS DRCMT-302)**

MMT Projects 580 0900 and 583 0900 titled "Automated Multiple Filter Life Tester" were completed by the US Army Armament, Munitions, and Chemical Command in January 1985 at a total cost of \$350,000 and \$367,000, respectively.

**BACKGROUND**

Currently, the filters/canisters used with protective masks are tested with a Q233 filter life tester. The tester has a low test rate since only two filters can be tested at a time. In addition, establishment and control of conditions for each test are labor intensive. Anticipated filter evaluation requirements for increased production and surveillance demonstrates the need for increased capacity.

Therefore, there is a need for an automated filter tester which would test more filters simultaneously. Also, it should be easier to use and more accurate to reduce manpower and increase reliability.

**SUMMARY**

The major objective of this project was to develop prototype test equipment which would evaluate the gas life of individual protective filters. The requirement for this tester was established to insure compliance with Training and Doctrine Command (TRADOC) gas life requirements for these filters.

Initially, a design concept for an automated multiple filter life tester was developed. The concept was basically a multiple chamber tester which allowed five filters to be tested simultaneously. Based on this concept, a tester was designed and fabricated by Systems and Applied Science Corporation.

The testing system was modular in design and is shown in figure 1. Each automated multiple filter life tester (AMFLT) subsystem was composed of a pump system, gas supply, and filter/cannister chamber.

The flow pump system consisted of a driven diaphragm cylinder which could produce an intermittent flow to simulate human breathing. A separate air pump was used to provide continuous flow. A humidifier was used to maintain the humidity within limits.

each time it was shown that a high particle count resulted. The drain tube was placed at three different positions: at the top, at the bottom, and at the liquid level (which varied as the level changed). It was found that keeping the tube at the liquid level gave the best results.

A comparison was made to determine which method was preferred. The accuracy of each method was determined by comparing the predicted and actual particle counts. Table 1 depicts the average error factor for each method.

TABLE 1

<u>Particle Size (Microns)</u>	<u>Avg. % Error (Dilution)</u>	<u>Avg. % Error (Recycle)</u>
5	5	86
15	5	83
25	8	87
50	11	73
100	16	48
250	0	10

It can be seen from Table 1 that the dilution method gives the best results. As a result, US Army Combat Systems Test Activity (CSTA) has recommended the use of the dilution method on all hydraulic fluids submitted to their chemistry laboratory.

#### **BENEFITS**

Accurate analysis of hydraulic fluid can be made with a sample as small as 25ml. A savings of \$180/sample can be obtained, increased accuracy is realized, rapid turn-around time is possible and a wider range of equipment can be serviced.

#### **IMPLEMENTATION**

All samples sent to CSTA will be tested using the dilution method and automatic particle counters.

#### **MORE INFORMATION**

Additional information may be obtained from William Deaver, AV 298-3677 or by obtaining the final technical report "Automated Particle Contamination Measurement in Hydraulic Fluids," report number USACSTA-6082, September 1984, published by the US Army Combat Systems Test Activity, Aberdeen Proving Ground, MD 21005-5059.

Summary report, Jun 85, was prepared by Frank Stonestreet, Manufacturing Technology Division, US Army Industrial Base Engineering Activity, Rock Island, IL 61299-7260

processes used to obtain the contour shape. There were six sub-assemblies fabricated each from forged components and from extruded components, except for the dome insert which was produced from a forging for both sub-assemblies. These were successfully fabricated utilizing processing operations which included forging, extruded sections, shear forming, profile milling, lathe turning, heat treat, electron beam welding, and hydraulic pressure testing. See figure 1 for the forging process diagram.

All twelve assemblies were hydraulic proof tested at 4,130 psig for one minute, and two assemblies were burst tested at 5,000 psig for one minute, with no failures or measurable deformation. There was no difference in the fabrication or proof test characteristics between the forged or extruded assemblies.

The Phase III requirements have been completed. Dimensionally and structurally acceptable scaled-up solid rocket motor cases, nominally 14-in. diameter x 0.143-in. wall thickness x 83-in. in length, were delivered to MICOM at the Redstone Arsenal, Huntsville, Alabama, for test firing.

The program has conclusively demonstrated that co-free maraging steel is an acceptable alternative material for rocket motor components. Manufacturing procedures have been established that will enable successful production of rocket motor components.

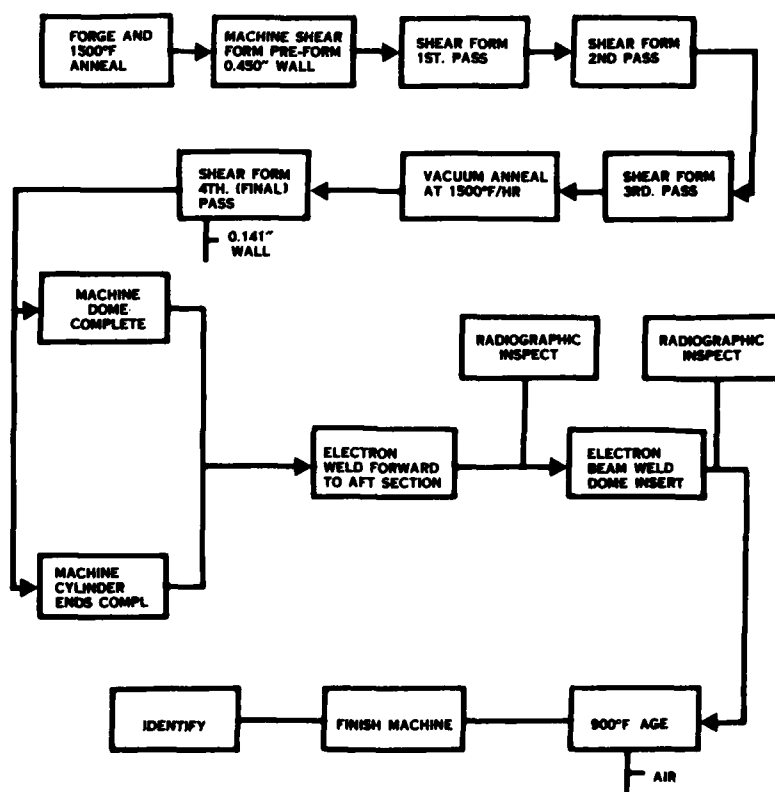

Figure 1 - Process Diagram for Forged Cylinder Sub-Assembly

## **BENEFITS**

This project provides a strategic benefit of reducing United States dependency on foreign sources of cobalt. The cost for cobalt maraging steel per unit is \$50.60 versus \$32.20 for cobalt-free maraging steel, resulting in a savings of \$18.40 per unit. Based on requirements of 30,000 units, a savings of \$522,000 can be realized.

The knowledge gained through testing and developing of manufacturing procedures for the production of rocket motor components can be applied to other products that specify maraging grade steel that contains cobalt.

## **IMPLEMENTATION**

Cobalt-free maraging steel is presently being used in the TOW Missile buy. Also, drawing changes are presently underway in the Stinger rocket motor project, since they plan to implement the use of cobalt-free maraging steel.

## **MORE INFORMATION**

Additional information may be obtained from Technical Report RK-CR-84-5 titled "Fabrication and Delivery of Cobalt-Free (Co-Free) Maraging Steel Rocket Motor Components" or by contacting Mr. William Crownover at MICOM, AV 746-5821 or Commercial (205) 876-5821.

---

Summary report, June 85, was prepared by Rolf Anderson, Manufacturing Technology Division, US Army Industrial Base Engineering Activity, Rock Island, IL 61299-7260.

**MANUFACTURING METHODS AND TECHNOLOGY  
PROJECT SUMMARY REPORT  
(RCS DRCMT-302)**

MMT Project T82 5090 titled "Improved and Cost Effective Machining Technology (Phase IV)" was completed by the US Army Tank-Automotive Command in September 1984 at a cost of \$250,000.

**BACKGROUND**

Many tracked combat vehicle components are subject to high recurring costs and long lead times. This is typically the result of poor manufacturing system performance. Often, machining technology selections are made without benefit of specific machining data, resulting in the use of costly tooling and leading to inefficient metal removal rates.

**SUMMARY**

The objectives of this project were threefold:

- (1) Perform an analysis of current and planned machining methods for tracked combat vehicle components;
- (2) Perform testing and evaluation of cutting tools, cutting fluids, and machining conditions;
- (3) Summarize study results in a series of data tables.

The latter should be broken down further according to recommended cutting tool, tool geometry, speed, feed, depth of cut, and cutting fluid for each work material and machine operation combination tested.

As noted in the summary report for Phases II and III of this effort, numerous parameters were addressed for turning, milling, drilling, and tapping operations. Machining tests were conducted using statistically designed models, with emphasis placed on difficult-to-machine parts and on alloys used in high volume components.

Machining test results have been published in the form of a handbook of machining data. This handbook contains separate data sections which present both modeled and historical data for turning, grinding, reaming, tapping, drilling, and several types of milling operations. An introductory section provides extensive explanatory material relative to work material designations, cutting tool descriptions, and cutting fluid nomenclature. In addition, an appendix has been included to provide guidance relative to chip control in turning operations.



## **BENEFITS**

The execution of this project has resulted in the development and documentation of machining parameters required for the efficient production of tracked combat vehicle components.

## **IMPLEMENTATION**

The results of this project were presented at an end-of-project presentation to representatives of industry and government. In addition, approximately 80 handbooks have been provided upon request to the industrial community.

## **MORE INFORMATION**

Additional information may be obtained from Ms. Janice Dentel, TACOM, AV 786-8718 or Commercial (313) 574-8718.

---

Summary report, June 85, was prepared by Alan Peltz, Manufacturing Technology Division, US Army Industrial Base Engineering Activity, Rock Island, IL 61299-7260.

**MANUFACTURING METHODS AND TECHNOLOGY  
PROJECT SUMMARY REPORT  
(RCS DRCT-302)**

MMT Projects 480 6059-06 and 482 6059-06 titled "M2 and M3 Fighting Vehicle System - Laser Heat Treating" were completed by the US Army Tank-Automotive Command in September 1984 and April 1985 at costs of \$257,000 and \$130,000, respectively.

**BACKGROUND**

Track shoes in infantry (M2) and cavalry (M3) fighting vehicles are subject to wear along the grousers, sprocket contact, and guide contact locations. (See figure 1.) These components are currently hardened by flame or induction hardening.

Surface hardening is accomplished by changing the structure of the metal on and close to the surface. This is carried out by heating the metal surface to a specific temperature range below its melting point and quenching rapidly to form a hard, wear-resistant surface. This treatment has the advantage of retaining the ductility of the core material while providing a harder, more wear-resistant surface.

The laser has been proposed for surface hardening. In this case, it is a heat source to rapidly raise the surface temperature. As the laser beam traverses the surface, the heat is rapidly conducted into the mass, thus producing a hardened surface layer.

**SUMMARY**

The objective of this project was to evaluate laser heat treatment to improve wear resistance along the specific locations shown in figure 1 by increasing surface hardness.

Laser surface hardening of the Bradley Fighting Vehicle (BFV) track shoes was performed at the Rockwell Science Center, Thousand Oaks, California. Eighty track shoes were surface hardened and evaluated by laboratory and vehicle tests to compare the wear properties of induction and laser surface hardened track shoes. The relative wear life of the laser heat treated shoes exceeded that of the induction hardened shoes up to 2.8mm (0.110 inches). Beyond this depth, the relative life of the induction hardened shoe exceeded that of the laser hardened shoe. The maximum difference in the relative lives of the track shoes occurred at a depth of approximately 2.00mm (0.08 inch). At this depth, the relative lives of the laser hardened shoes exceeded that of the induction hardened shoes by approximately 17 percent.

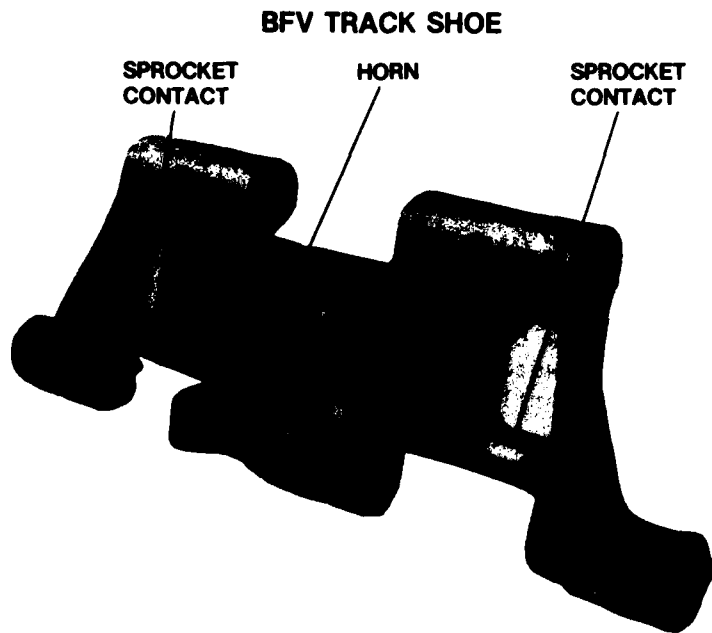

Figure 1 - Sprocket contact and horn regions of track shoe that are surface hardened

An economic evaluation was performed on the two processes. The laser system utilized a 5 kw laser beam generator, a beam integrator for removing hot spots in the beam, and a 3-axis control table for moving the shoe under the beam. A 200-second cycle time for heat treating the grouser, horn, and sprocket contact regions was successfully accomplished with this program. The laser process did not require quenching or tempering, as did the induction process, but the surfaces to be laser hardened needed to be coated with a black paint to absorb the beam energy.

The induction process analysis was developed from existing process parameters and equipment specifications currently utilized at FMC's Anniston facility for surface hardening track shoes. For comparison purposes, both the laser and induction process economic analyses assume that no facilities exist and the proposed facility would utilize automated material handling equipment so that an optimum cycle time per part for each process could be achieved.

The results of the analysis indicated that the existing induction process is slightly more than half the cost per part of the laser process (\$1.88 vs. \$2.90). The parameter which contributes most to the laser process being more costly is the cycle time per part. The laser system with 100 percent beam utilization requires a 200-second cycle time per part under optimum conditions. The laser process, therefore, requires 6 or more work cells to meet the equivalent production capability of each induction process work cell and this is the major contributing factor for the higher cost of the laser process.

## **BENEFITS**

Laser heat treating has been proven to provide longer wear life up to about 1/10th. of an inch in depth in track shoes. For wear requirements beyond this, the induction hardening process results in longer wear life.

## **IMPLEMENTATION**

There is no planned implementation in this particular application due to the cost/wear requirements relationship for track shoes.

## **MORE INFORMATION**

Further information may be obtained from Mr. Mike King, TACOM, AV 786-6065 or Commercial (313) 574-6065. Reference TACOM Technical Report No. 13008 titled "Manufacturing Methods and Technology Investigation of the Technical and Economic Advantages of Laser Hardened Track Shoes," June 1984.

Summary report, June 85, was prepared by Robert Hellem, Manufacturing Technology Division, US Army Industrial Base Engineering Activity, Rock Island, IL 61299-7260.

**MANUFACTURING METHODS AND TECHNOLOGY  
PROJECT SUMMARY REPORT  
(RCS DRCMT-302)**

MMT Project 679 7482 titled "Modified Ribbon Rifling Generating Machine" was completed by the US Army Armament, Munitions, and Chemical Command in March 1984 at a cost of \$74,100.

**BACKGROUND**

Watervliet Arsenal is a manufacturer of medium and large caliber artillery weapons. The primary component of these weapons is the cannon tube, most of which employ a rifled bore in order to impart a rotational force to the projectile as it is fired. Currently, all rifling is accomplished on dedicated, mechanically controlled broaching machines. These broaching machines employ a different rifling bar for each of the various rifling configurations. A complex mechanical linkage must be re-established every time a different rifling configuration is produced, resulting in an average setup time of eighty hours.

**SUMMARY**

The objective of this project was to study the design and application of several alternative methods for producing rifling grooves in cannon tubes. The methods investigated involved essentially two different approaches.

The first approach was to investigate modification of existing equipment. A system was designed which employed digital measuring devices coupled with a hydro-mechanical tracer system. During the time procurement-related problems were being addressed, a re-evaluation of this system by Operations Directorate personnel resulted in the cancellation of a retrofit approach. It was then decided to concentrate on evaluation of the feasibility of developing a CNC rifling machine.

As a first step in this CNC evaluation, an industry survey was conducted to determine the extent to which CNC technology was being employed in the production of helical grooves. It was discovered that the vast majority of rifling machines being used today employ the same rifling (lead) bar system presently in use at Watervliet Arsenal. CNC systems were not found being applied in any medium or large caliber broaching applications.

Overall, the machine tool builder community indicated that CNC rifling systems have been seriously considered and are viewed as viable. Projected high development costs and a limited world market potential, however, have prevented any actual developmental work from being undertaken.

After completion of the industry survey, a CNC Rifling Machine Project Description was prepared for use as the basis of a contractual feasibility study relative to CNC rifling for medium and large caliber cannon tubes. This Project Description identified 15 requirements that were to be addressed in the feasibility studies. Two studies were conducted; one by Estech and the other by Lapointe Broach Company. Figure 1 shows the approach proposed by the former.

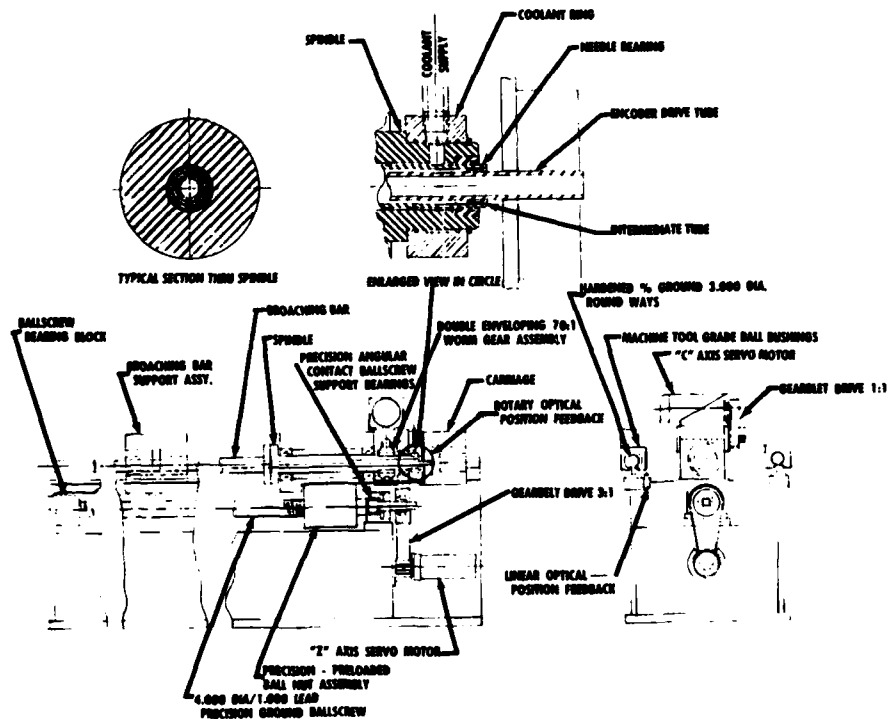

Figure 1 - CNC Rifling Machine

Both studies concluded that the CNC rifling was applicable to Watervliet Arsenal's manufacturing operations. However, during the course of these investigations and studies, Watervliet Arsenal re-evaluated its position on the use of CNC rifling and concluded that potential cost savings did not warrant the development of a CNC rifler.

## **BENEFITS**

This project has defined the performance requirements of CNC rifling equipment. It also documented the results of feasibility studies which concluded that CNC rifling is viable for the manufacture of medium and large caliber cannon tubes. In this regard, it has provided the basic information necessary for CNC rifling development.

## **IMPLEMENTATION**

Watervliet Arsenal re-evaluated its position on the use of CNC rifling and determined it would not pursue development of a CNC rifling capability at the present time. The results of this project have not, therefore, been implemented.

## **MORE INFORMATION**

Additional information may be obtained by contacting Mr. Alex Wakulenko, Benet Weapons Laboratory, AV 974-5737 or Commercial (518) 266-5737.

---

Summary report, June 85, was prepared by Alan Peltz, Manufacturing Technology Division, US Army Industrial Base Engineering Activity, Rock Island, IL 61299-7260.

**MANUFACTURING METHODS AND TECHNOLOGY  
PROJECT SUMMARY REPORT  
(RCS DRGMT-302)**

MMT Project 682 8050 titled "Recycling Spent Gun Tubes by ESR Melting" was completed by the US Army Armament, Munitions, and Chemical Command in September 1984 at a cost of \$142,000.

**BACKGROUND**

Conservation of critical alloys that must be imported into this country has become extremely important. Many gun tubes are regularly fired-out and discarded for scrap value at a great monetary loss.

Several years ago, a program was initiated to recycle the larger size gun tubes; 155mm, 175mm and 8", by rotary forging them into smaller tubes. However, there is no requirement for a gun tube smaller than 105mm that would justify retooling the large rotary forge to use this same technique on the 105mm tubes.

The 105mm gun tubes, which are produced in the greatest quantity, require a special technique to recycle them back into 105mm tubes. In addition, 175mm and 8" tubes of very old vintage are unsuitable for direct recycling by rotary forging because of the impurity level of sulphur which is not consistent with that of the modern tubes.

Electroslag refining (ESR) is a process by which a conventionally cast ingot is remelted under a molten slag cover to further purify the previously melted material.

**SUMMARY**

The objective of this project was to prove that spent gun tubes can be remelted by the ESR process, conserving the critical alloys and producing a material equal in quality to the present material being used.

The ESR process (see figure 1) was used to individually remelt three fired-out 8" M2A2 gun tubes into individual solid ingots. These ingots were then forged into preforms and rotary forged into the configuration of 105mm gun tubes. Discs were cut from the breech and muzzle end to provide test specimens so that the mechanical properties of the material could be tested and analyzed. Also, heat treating specifications were developed.



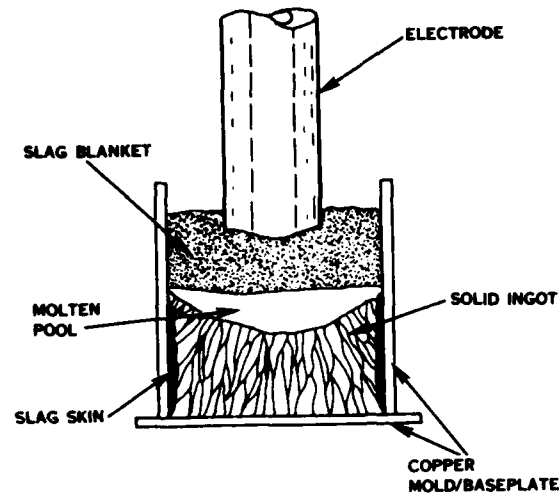

Figure 1 - ESR Process

The ESR melting and subsequent forging and heat treating of the material produced a product with mechanical properties superior in quality to the material presently being used.

This project has proven two very important points:

1. The ESR process of remelting under a molten slag cover removed large amounts of sulphur from the steel, thereby lowering sulfide and other inclusions which are detrimental to the quality of the material.
2. The other chemical elements are not affected in this process so there is no loss of critical elements such as nickel, chrome, molybdenum or vanadium.

The ESR refining, melting and subsequent forging of ingots into 105mm gun tubes is a viable process for recycling the large quantities of spent 105mm gun tubes that have normally been sold for scrap. This process will provide a means to recycle the old vintage 175mm and 8"mm gun tubes presently unsuitable for direct recycling because of the high sulphur impurity level. This process will also allow recycling of other large caliber tubes into whatever size gun tubes are required at the time. There appears to be no limit on the number of times a gun tube can be recycled through the ESR method.

#### **BENEFITS**

This project is beneficial in proving that the ESR process of remelting spent gun tubes will conserve critical alloy elements such as chrome, nickel, molybdenum, and vanadium that are required in high quality gun steel.

The ESR process offers a feasible technique to conserve critical material by recycling the 105mm M68 gun tubes presently being scrapped.

This project has also provided a method by which out-of-date models of gun tubes can be ESR melted into ingots to produce others that are currently required.

The ESR method of recycling spent gun tubes offers a monetary savings which will vary depending on the market price of steel. Presently, the market is depressed and a \$300 saving per 105mm M68 gun tube can be realized. This savings could realistically increase to \$700 when the steel market price improves.

#### **IMPLEMENTATION**

No difficulties are anticipated in implementing this project. The plan is to return worn out gun tubes directly from the field to private contractors and remelt them into ESR ingots. These ingots will then be further processed into either rotary forged preforms or forged gun tubes to be sent to Watervliet Arsenal for final machining into cannon barrels.

Watervliet Arsenal is presently in the process of pursuing implementation.

#### **MORE INFORMATION**

Additional information can be obtained from the AMCCOM project officer, V. J. Colangelo, AV 974-5827 or Commercial (518) 266-5827.

---

Summary report, June 85, was prepared by Rolf Anderson, Manufacturing Technology Division, US Army Industrial Base Engineering Activity, Rock Island, IL 61299-7260.

**MANUFACTURING METHODS AND TECHNOLOGY  
PROJECT SUMMARY REPORT  
(RCS DRCMT-302)**

MMT Project 682 8113 titled "Establishment of Ion Plating Process for Armament Parts" was completed by the US Army Armament, Munitions and Chemical Command in March 1984 at a cost of \$142,000.

**BACKGROUND**

Cadmium electroplating has been the preferred method for protecting steel for many years. Obvious problems with its use were minimal prior to the use of high strength steel and aluminum alloys. Cadmium electroplating on high strength steel often caused hydrogen embrittlement, and cadmium plated fasteners installed in high strength aluminum alloy components promoted exfoliation in the countersinks. More recently, it has received further disfavor because it was found to cause solid metal embrittlement of titanium structure and because of its toxicity and harmful effects on the environment.

Over 3,000 armament components are currently electroplated with cadmium. All DOD organizations are committed to replace toxic cadmium wherever feasible. There is an equal need to alleviate the potential for hydrogen embrittlement failures in armament components as well. Aluminum ion plating has been proposed as an attractive alternative to electroplated cadmium.

**SUMMARY**

The objective of this project was to establish and document the process parameters and coating requirements for aluminum ion plating of armament components. The basic equipment required for ion vapor deposition (IVD) is a steel vacuum chamber, a vacuum pumping system, an evaporation source and a high voltage power supply. A schematic of a typical IVD unit is shown in figure 1. The process sequence consists of pumping the system down to about  $10^{-4}$  Torr. The chamber is then backfilled with an inert gas to about 10 microns and a high negative potential is applied between the parts being coated and the evaporation source. The gas becomes ionized and creates a glow discharge around the parts to be coated. The positively charged gas ions bombard the surface of the parts and give them a final cleaning. Clean surfaces are essential for good coating adhesion.

After the glow discharge cleaning process, commercially available aluminum wire (1100 alloy) is evaporated by continuously feeding it into resistance heated crucibles. As the aluminum vapor passes through the glow discharge, a portion of it becomes ionized. Bombardment by the inert gas ions accelerates the aluminum vapor toward the surface of the part, resulting in denser coatings and improved coating adhesion. The ionization also provides better throwing power and allows complex shapes to be more uniformly plated. The total coating cycle requires about 45 minutes.

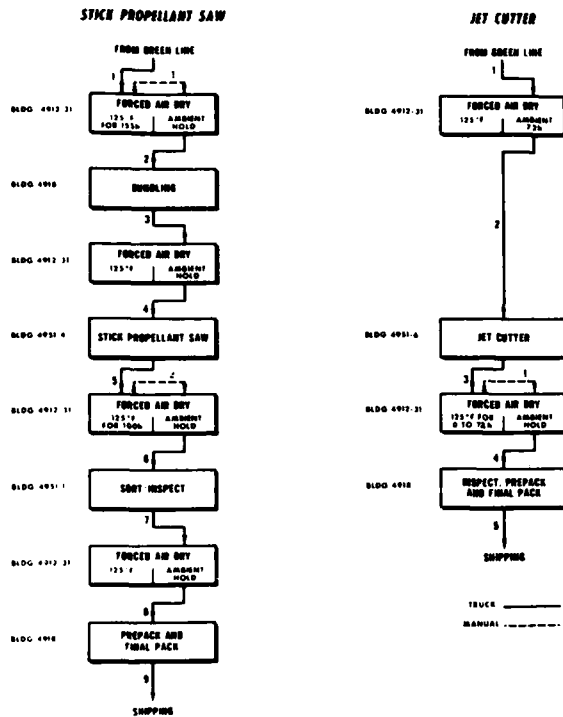

Figure 2 - Transportation Steps of Benite Processing

Other conclusions about the fluid jet cutter are summarized as follows: Because the kerf is only a few thousandths of an inch wide, the loss of material is small. The material that is cut out by the fluid exits the cutting station as a slurry that can be disposed of or reclaimed. As a result, there is no airborne dust generated. The jet never dulls, and frictional drag is eliminated making a coolant unnecessary. The degree of wetting is therefore limited to a very small area. Also, water is an optimum cutting fluid because, in most cases, it does not adversely affect product quality. The cutting action does not mutilate the edges of soft materials and does not cause sparking when embedded metal is encountered. The compact nozzle requires very little space at the cutting station, permitting easy mounting and guarding. Finally, the electrical and pressurization equipment can be remotely located.

#### BENEFITS

1. The fluid jet cutter has the capability of cutting benite and other stick propellant products to specification length without strand breakage and chipping.

2. Cutting of dry energetic materials can be accomplished without a coolant deluge, resulting in a significant reduction in drying time and a general improvement in the quality of the product.

modifications resulted from this investigation. The change in hazards classification will also influence present and future handling and storage of benite.

Necessary building modifications were carried out and a prototype jet cutter facility consisting of four bays was built. After evaluating the equipment of two principal vendors, a contract was awarded to supply the fluid jet cutter shown in figure 1. After initial debugging and a checkout with inert simulant, evaluation was carried out with live benite. The effects on cutting of jet pressure, orifice diameter, feed rate and bed depth were determined.

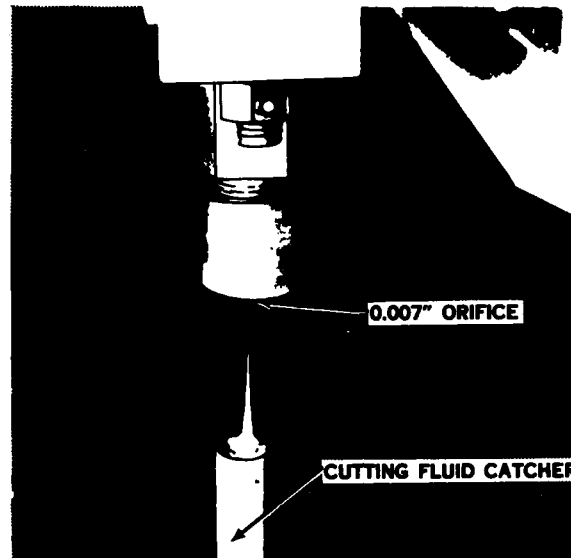

Figure 1 - Fluid Jet Cutter

Performance testing of the jet cut benite was conducted with M83 electric primers. Ten pounds each of jet cut and conventional mechanically saw cut benite were loaded into primers at Lone Star AAP and shipped to ARDC for static test firings. The settings for cutting with the jet cutter were:

pressure	55,000 psi
orifice diameter	0.007 inch
belt rate	4 ft/min
bed depth of benite	1/2 to 5/8 inch

Static testing of the jet and saw cut benite was conducted at -50°F, 70°F and 145°F.

A statistical analysis was then performed at ARDC for the purpose of comparing the two benite cutting operations - conventional sawing and the fluid jet cutter. The analysis concluded that there is no significant quality difference between the two. Figure 2 shows the reduced number of processing steps for the jet cutter.

**MANUFACTURING METHODS AND TECHNOLOGY  
PROJECT SUMMARY REPORT  
(RCS DRCMT-302)**

MMT Project 580 4210 titled "Jet Cutting of Energetic Materials" was completed by the US Army Armament Research and Development Center (ARDC) in October 1984 at a cost of \$620,000.

**BACKGROUND**

The name "benite" was coined from the description terms "black powder/extruded/nitrocellulose." As implied, it is a single-base propellant consisting of a homogeneous matrix of potassium nitrate, sulfur, charcoal, ethyl centralite, and nitrocellulose. The material is first colloided with alcohol and ether solvents to permit extruding into 2.16mm diameter strands. The resulting product is dried, tied into a bundle, dried again, sawed, redried a third time, untied, sorted, inspected, redried and finally packaged. Ultimately, it is used as ignition material in a variety of artillery ammunition products.

The conventional method of cutting these stick propellant strands to specification length is with carbide-tipped circular saw blades mounted on a common arbor. This involves excessive propellant handling and drying time. An analysis showed that substantial savings might be possible by changing the cutting technique to a method that would not require a coolant and would not cause strand breakage or chipping. Five alternatives were considered, which, in turn were narrowed down to one: a high pressure fluid jet cutting system. The jet cutter was recommended for further study because of its likely advantages over the other cutters. Already, the technique is well established for cutting and trimming in the aerospace, auto, corrugated board and other industries.

**SUMMARY**

The objective of this project was to develop a fluid jet cutting system that would reduce operating costs and improve safety. It was decided to install and test a prototype production system for cutting benite strands to length at Radford AAP. The fluid jet cutting technique uses a narrow beam of deionized water at very high pressures as the cutting tool.

A contract was awarded to Radford AAP in July 1980 to carry out this project. Initially, a program was conducted to investigate changing the benite hazard classification from 1.1 (explosive) to 1.3 (fire). Tests indicated benite to be a low mass burning rate propellant and resulted in a change to a 1.3 hazards classification. Significant savings for building

# MUNITIONS

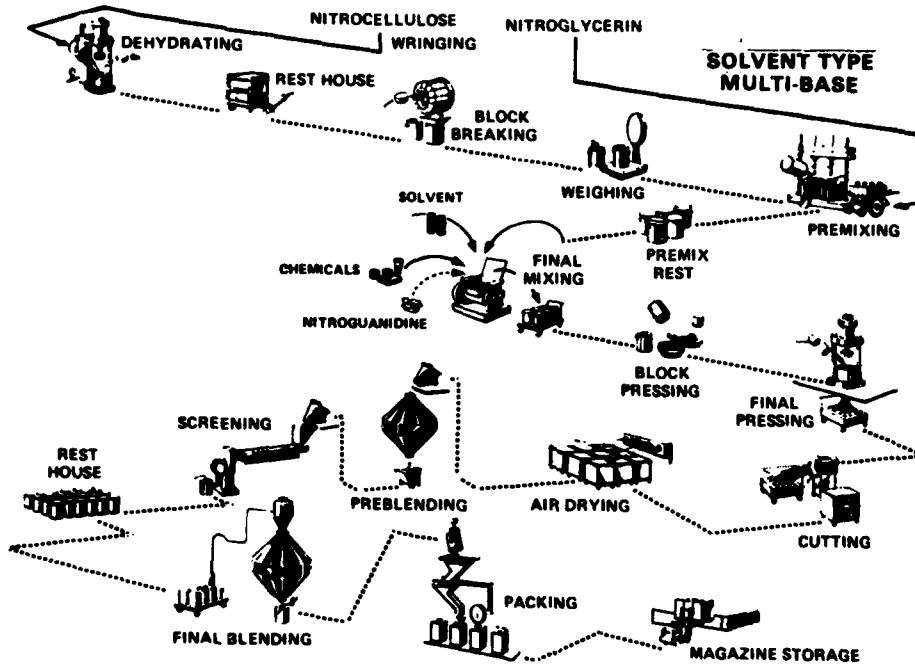

## CONVENTIONAL PROPELLANT MANUFACTURE

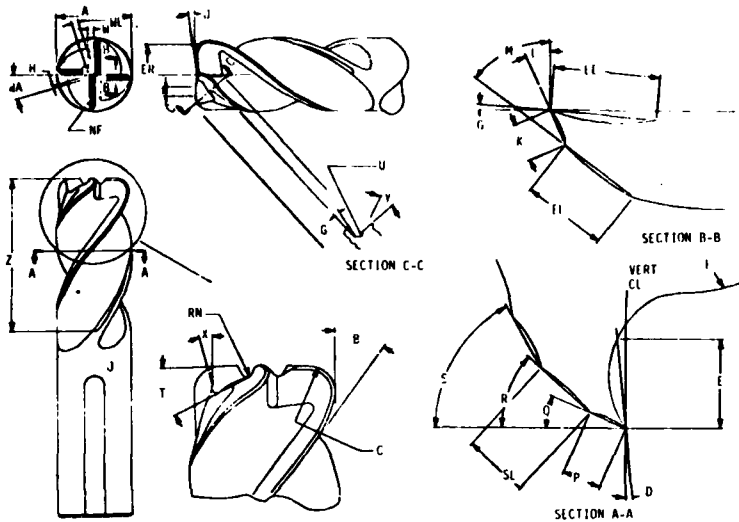

Figure 2 - Cutter Geometry

As a result of these tests, it was determined that tool life may be significantly improved by increasing primary and secondary clearance angles, and increasing the primary land width. Increasing the helix angle was found to be detrimental to tool life as was increasing the rake angle. Increasing feed rates was found to have little or no effect on tool life for certain operations. A technical report containing detailed documentation of the results of this two-year effort has been prepared.

#### **BENEFITS**

The execution of this project has resulted in a significant reduction in tooling costs associated with all military turbine engine blisk and impeller manufacture. Total savings associated with the implementation of this effort is estimated to be approximately \$9.3 million.

#### **IMPLEMENTATION**

The results of this effort have been implemented at General Electric Company, Hookset, New Hampshire, in the production of military turbine engine components.

#### **MORE INFORMATION**

Additional information may be obtained by contacting Mr. N. Singh, AV 693-2294 or Commercial (314) 263-3353.

Summary report, June 85, was prepared by Alan Peltz, Manufacturing Technology Division, US Army Industrial Base Engineering Activity, Rock Island, IL 61299-7260.



**MANUFACTURING METHODS AND TECHNOLOGY  
PROJECT SUMMARY REPORT  
(RCS DRGMT-302)**

MMT Projects 781 8190 and 782 8190 titled "Improved Blisk Impeller Cutter Life" were completed by the US Army Troop Support Command in March 1983 and April 1984 at costs of \$225,000 and \$486,000, respectively.

**BACKGROUND**

The expense of purchasing end mill tooling associated with machining T-700 turbine engine blisk and impeller airfoils is approximately \$2400 per engine. An additional \$370 per engine is expended in the changing of cutters. These costs are excessively high.

**SUMMARY**

The objective of this effort was to reduce, by 50 percent, the end mill tooling and tooling related costs associated with the machining of T-700 turbine engine blisk and impeller airfoils by increasing tool life. Tooling material and geometry, as well as machining feeds and speeds, were investigated in order to identify parameters most significantly related to tool life. See figure 1.

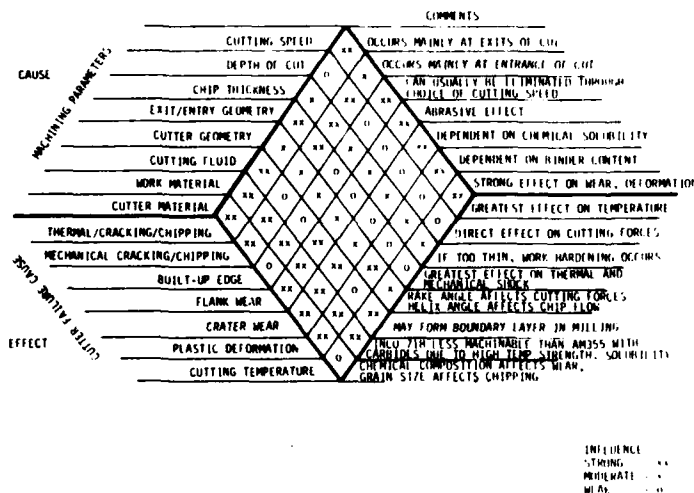

Figure 1 - Correlation Matrix Between Machining Parameters and Cutter Failure Causes

Initially, tests were conducted with parameters such as tool material, tool geometry, and machining speeds and feeds; parameters being varied one at a time. Initial test results were then used to construct a statistically designed experiment in which the combined effect of tool material, tool geometry, and machining speeds and feeds were studied. Figure 2 shows some of the complex geometry studied for cutters.

This project has established straightness criteria and has perfected a dual point loading device which eliminates hot straightening of gun tube forgings at a cost savings of \$300.00 per tube. At present, this is worth at least \$15,000 per year.

#### **IMPLEMENTATION**

The straightening criterion, when approved by the Benet Weapons Laboratory Management, will be incorporated as a requirement on the appropriate tube drawings. The dual point loading device will be used by the Watervliet Arsenal Production Facility to straighten gun tube forgings. Implementation is proceeding as planned for implementation in July 1985.

#### **MORE INFORMATION**

Additional information may be obtained by contacting Mr. William Garber, Watervliet Arsenal, Watervliet, NY 12189, AV 974-5319 or Commercial (518) 266-5319.

---

Summary report, June 85, was prepared by Rolf Anderson, Manufacturing Technology Division, US Army Industrial Base Engineering Activity, Rock Island, IL 61299-7260.

The amount of out-of-straightness that can be removed is a function of the distance between supporting anvils and the method used, i.e., single point loading or dual point loading.

The results from a study made of hot (600°F-1000°F) straightening versus cold (room temperature) straightening indicated no significant benefit from hot straightening. The actual strain from hot straightening is approximately the same as for cold straightening. The amount of residual longitudinal stress that exists is somewhat less (70-80 percent) than after cold straightening. However, this difference is not considered to be significant.

Greater gun tube deflections can be corrected by dual point loading without exceeding 2 1/2 percent maximum strain (figure 1). This provides a method of cold straightening gun tubes with out-of-straightness exceeding 0.240 TIR/ft.

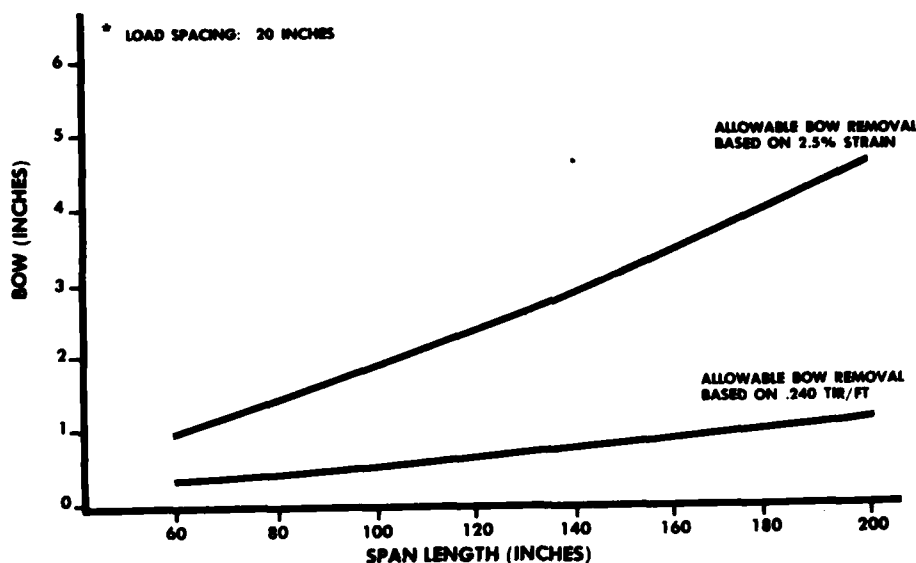

Figure 1 - VS Span Length for 155mm M185

#### BENEFITS

Straightening with dual point loading allows much larger bends to be removed than with the single point loading. The dual point loading method resulted in one-half the amount of total strain and 70-80 percent of the residual longitudinal stress from the single point loading method.

**MANUFACTURING METHODS AND TECHNOLOGY  
PROJECT SUMMARY REPORT  
(RCS DRGNT-302)**

MMT Project 682 8242 titled "Dual Press Straightening Gun Tubes" was completed by the US Army Armament, Munitions, and Chemical Command in December 1984 at a cost of \$118,000.

**BACKGROUND**

The present method of straightening gun tube forgings with a single point load creates large residual stresses and large local plastic strains which decrease material toughness. The straightening of gun tube forgings is currently being done on a single ram hydraulic press. This method of straightening applies a load at one point on the tube in order to remove the out-of-straightness. The straightening press operator determines by trial and error at which location to place the support anvils, where to locate the loading ram of the press, and the amount of load or deflection required to straighten the bend in the gun tube. The tube is then bent and measured as required until the out-of-straightness is removed to within predetermined limits.

Presently, tubes are straightened at room temperature (cold straightening) providing the bend does not exceed 0.240 TIR (total indicator reading) per foot. If the out-of-straightness exceeds this amount, the tube must be heated to approximately 1000°F. During hot straightening, a temperature of 600°F to 1000°F must be maintained.

**SUMMARY**

The objective of this project was to improve the method used in straightening gun tube forgings and to establish engineering criteria for cold straightening of gun tubes.

The criterion of 2 1/2 percent maximum allowable strain that any tube will experience during straightening was established. It was also decided to investigate the use of a dual point loading device instead of just the conventional single point pressure point. The second one was mounted to the existing straightening hydraulic press.

A theoretical mathematical equation was developed for the allowable bend (permanent deflection) versus distance between supporting anvils. The theoretical equation was validated through measurement of load versus deflection, load versus strain, and deflection versus strain. The validation of the equation proved to be reasonably accurate for strain and deflection amounts that are applicable for gun tube straightening calculations.

## **BENEFITS**

The use of composite anodes will eliminate off-side plating caused by a bent anode. Presently, to correct this plating problem, an estimated 50 hours of grinding time, at \$33.56 per hour, is required. For the 8-inch cannon with a yearly production of 40 tubes, a cost savings of \$67,120 can be realized. When the 120mm XM256 with a proposed production of 720 tubes is considered, the combined cost savings of \$1,275,000 is possible. The non-quantifiable benefits of a lightweight, stiffer composite anode are very attractive. Heavy angle iron anode carriers will not be needed to move and store anodes.

## **IMPLEMENTATION**

The composite anode will be implemented into the production cycle for large caliber tubes after the flow-thru plating equipment has been transferred to the new production facility. In the meantime, the anode will be used on an experimental basis to determine its maximum electrical current carrying capacity.

## **MORE INFORMATION**

Additional information may be obtained by contacting Mr. R. Murray, Benet Weapons Laboratory, AV 974-5682 or Commercial (518) 266-5682. The final technical report, ARLCB TR-84042, is titled "The Development of a Large Composite Anode for Plating Gun Tubes," dated December 1984.

---

Summary report, June 85, was prepared by Robert Hellem, Manufacturing Technology Division, US Army Industrial Base Engineering Activity, Rock Island, IL 61299-7260.

## 105MM/120MM COMPOSITE ANODE

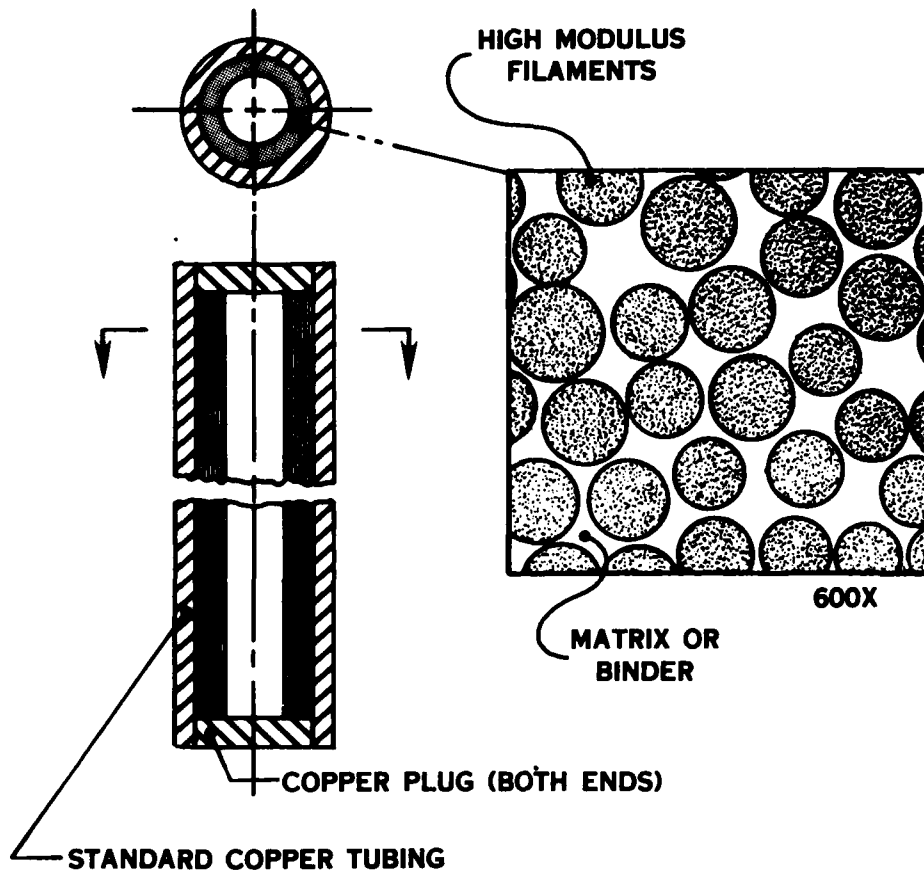

Figure 1 - Anode Cross-Sectional Sketch

The thermal expansion molding (TEM) technique was selected as the means of fabricating the composite anode. The initial step of this process was to hand lay-up two-inch wide graphite epoxy tape into the steel mold. Then the silicone rubber mold was inserted and capped with the aluminum plate. The entire assembly was then oven cured. During curing, the silicone expanded thereby pressuring the unidirectional composite at the inside diameter.

Testing of the composite anode was conducted by chrome plating a 105mm rifled steel liner. The liner was first electropolished to remove sufficient steel stock to allow for a 10 mil thickness of low contractile chrome. As predicted, no problems were experienced with the composite anode when subjected to a current density of  $90 \text{ amp/dm}^2$ . From these results, it was concluded that it is possible to construct a plating anode using composite materials. The composite anode is considerably lighter which greatly enhances its transportability. The highly rigid anode will withstand rough handling without incurring permanent deflections. This eliminates the need for straightening or remaking anodes. Straighter anodes produce more uniform deposits during plating.

**MANUFACTURING METHODS AND TECHNOLOGY  
PROJECT SUMMARY REPORT  
(RCS DRGMT-302)**

MMT Project 681 8152 titled "Improved Anode Straightness for Chromium Plating" was completed by the US Army Armament, Munitions, and Chemical Command in June 1984 at a cost of \$280,000.

**BACKGROUND**

Two of the basic requirements in an anode are straightness and mechanical rigidity. Straightness and rigidity are important for maximum and uniform distribution of current. A solid copper rod is presently used for this purpose. Although the anodes are fabricated as straight as possible and are carefully preserved in this condition by vertical suspension, straightness is still a recurring problem and is reflected in the economics of reworking a badly plated cannon tube.

**SUMMARY**

The objective of this project was to develop an improved method of fabricating the core for the anodes used to deposit chromium to large bore gun tubes. The approach was to develop a composite anode using unidirectional, graphite filaments that would have specific strength and specific modulus 33 and 9 times higher than copper, respectively. See figure 1. The new technique would provide an anode lighter in weight and sufficiently rigid to preclude bending and kinking when in use. The anode stiffness design criteria was that the finished anode mid-span deflection (due to its own weight) when simply supported at its ends should not exceed 0.5 inches and/or take a permanent deflection. The anode would be designed to withstand a reasonable amount of abuse through normal handling during assembly and disassembly. A horizontal load factor of three, i.e., when supported at each end, the anode should withstand three times its finished weight. The electrical capacity of the finished anode should be capable of carrying 90 amp/dm<sup>2</sup> (900A/ft<sup>2</sup>) for a duration of four hours.

Because of the requirements for a highly rigid and lightweight anode, it was decided to investigate a graphite epoxy construction. From several fibers evaluated, Union Carbide VSC-32 graphite fiber was selected to meet the stringent deflection requirements. An epoxy matrix of DOW 324 was selected to provide the long pot life necessary for the fabrication process.

The hand lay-up method was chosen as the means of composite construction. It is a processing technique which can utilize various fiber types and resins and can be used to fabricate any desired shape. In the hand lay-up technique, both tows and tapes were candidate fiber forms. The tape form was selected since it provides a uniform component and a controllable fiber volume.

## **IMPLEMENTATION**

The ion plating process is available for implementation in armament part applications. Discussions and analyses with project engineers on specific candidates for implementation are necessary to clarify the specification changes needed and the potentials of cost reduction for the individual items. Additional funding support for the implementation task is needed.

## **MORE INFORMATION**

Additional information may be obtained by contacting C. Feng, ARDC, AV 880-5746 or Commerical (201) 328-5746.

---

Summary report, June 85, was prepared by Robert Hellem, Manufacturing Technology Division, US Army Industrial Base Engineering Activity, Rock Island, IL 61299-7260.



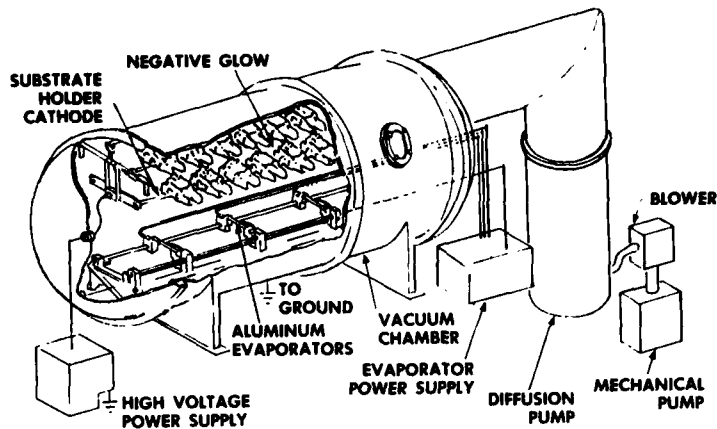

Figure 1 - Schematic of an Ion Vapor Deposition System

The parts are generally chromate treated after being coated. This provides additional protection against corrosion. Chromate treatment also provides a good base for paint adhesion which is a common requirement for aluminum surfaces.

The previous year project scope of work involved evaluations on coating thickness, distribution of deposit, adhesion, corrosion resistance, and faster qualification tests. The ion vapor deposition (IVD) process was also evaluated.

This project completed the evaluation of several test specimens, and process parameters optimization was accomplished. IVD aluminum coatings have several advantages over electroplated cadmium. It provides good coating distribution and eliminates hydrogen embrittlement. It is non-toxic and has a higher service temperature (925°F vs. 450°F for cadmium).

#### **BENEFITS**

This program has established an IVD aluminum coating process and associated equipment suitable for coating armament components. The IVD process provides the best adhesion and most uniform coating thickness when compared with physical vapor deposition and chemical vapor deposition. The contractor's experience in production has shown the processing costs for IVD aluminum to be comparable to vacuum cadmium but slightly greater than electroplated cadmium. However, if pollution abatement costs are included in the costs for electroplated cadmium, then the IVD process becomes even more cost effective. When substituting IVD aluminum for cadmium or other coatings, care should be taken to insure that the coating is being used for corrosion protection. In those cases where lubricity and/or wear-resistance is required, a case by case evaluation of the substitution is advisable.

3. The jet cutter is an inherently safe method of cutting energetic materials. It was shown that safety was enhanced in benite production by elimination of the earlier hazardous bundling operation. This is a manual process that exposes operators to benite in a very dry, easily ignitable state.

4. Production costs of benite can be significantly reduced with the use of the jet cutter. Besides the time savings, due to fewer stops, scrap was reduced by 32 percent. Total energy savings of \$108 per 1000 pounds of finished benite was obtained.

#### **IMPLEMENTATION**

This project provided a full-scale prototype facility for handling production quantities of benite during 1985. Furthermore, it has flexibility for potential applications with other propellant processes as well.

#### **ADDITIONAL INFORMATION**

Additional information may be obtained by contacting the ARDC project officer, Mr. W. Leach, AV 880-3637 or Commercial (201) 724-3637. Also, a Technical Report, ARLCD-CR-84013, "Fluid Jet Cutting of Energetic Materials" was published by ARDC in August 1984.

---

Summary report, June 85, was prepared by Wayne Hierseman, Manufacturing Technology Division, US Army Industrial Base Engineering Activity, Rock Island, IL 61299-7260.

**MANUFACTURING METHODS AND TECHNOLOGY  
PROJECT SUMMARY REPORT  
(RCS DRGMT-302)**

MMT Project 581 4231 titled "In-Plant Reuse of Pollution Abated Waters" was completed by the US Army Armament Research and Development Center in September 1984 at a cost of \$446,700.

**BACKGROUND**

The Federal Pollution Control/Clean Water Acts of 1972 and 1977 established that the discharge of pollutants into navigable waters shall ultimately be eliminated. Although this extreme has not been promulgated, the Environmental Protection Agency (EPA) has established lower interim standards and guidelines for AAP wastewater discharges.

Attainment of zero discharge may entail the development of advanced technology and/or expensive replicate treatment via state-of-the-art. Costs of pollution abatement are expensive and new facility abatement project costs are likely to become prohibitive. Also, related problems such as the question of treatment plant sludge disposal are arising, and abatement plant throughput must be minimized.

The most direct way to achieve zero discharge of pollutants is not to discharge plant effluent in the first place. This concept combines abatement of wastewater contamination by some method of current state-of-the-art treatment with recycle and reuse of the abated wastewater within the plant.

**SUMMARY**

The main objective of this project was to abate water pollution at AAP's by recycling and reusing water while concurrently recovering waste acids and other contaminants for reuse. Two plants in particular were chosen for study - the Lone Star AAP (LSAAP) and the Milan AAP (MAAP).

Work was conducted at LSAAP to establish process water specifications, determine the quality and quantity of pollution abated waters, evaluate the practicability and economics for recycle/reuse, and to determine the minimum required treatment prior to recycle-reuse. Several areas of the plant were selected as potential candidates for recycle/reuse of pollution abated waters. As a result of this work effort, it was determined not to be economical at this time to recycle/reuse pollution abated waters at LSAAP. However, if discharge limits become more stringent, technology is available for implementation.

Work was conducted at MAAP in two steps. The first, Phase I, was to determine the practicability, economics, and minimum required treatment prior to recycle/reuse of pollution abated waters at this facility. Several areas of the plant were selected as potential candidates for recycle/reuse.

Based on the results from the Phase I feasibility study, it was determined that a large percentage of MAAP's wastewater is generated on Line "0". See figure 1.

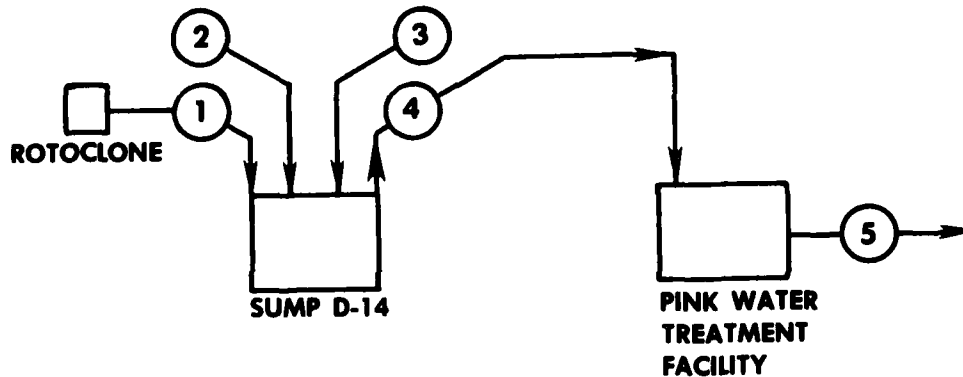

Figure 1 - Process Flow Diagram, Line "0", MAAP

Line "0" is a rework line with the major quantity of wastewater generated from washout operations. Wastewater in this process area is contaminated with a variety of chemicals and explosives (i.e., RDX, HMX, Comp B, Comp A-3, Comp A-5, tetryl, etc.). The contaminants in the wastestream are present in unpredictable quantities.

As a result of the pilot study, Phase II, it was determined that following settling and filtration, wastewater generated from Line "0" can be recycled and reused directly in washout operations. This results in a significant reduction in wastewater that must be treated in the MAAP pink water treatment facility.

## **BENEFITS**

As a direct result of this project, less water will have to be treated at MAAP with attendant cost savings. For both LSAAP and MAAP, important knowledge was gained to be able to apply more strict standards for wastewater discharges.

## **IMPLEMENTATION**

Results from the MAAP work effort have been self-implemented into process operations. At LSAAP, should water discharge limits become more stringent, technology is available to implement recycle/reuse measures under future modernization or MCA projects.

## **MORE INFORMATION**

Additional information on this project can be obtained by contacting Mr. J. M. Swotinsky at the US Army, Armament Research and Development Center, AV 880-4284 or Commercial (201) 724-4284. Also, four technical reports have been published covering the various studies carried out.

ARLCD-CR-83001 March 1983	"In-Plant Reuse of Pollution Abated Waters Phase I - Lone Star Army Ammunition Plant"
ARLCD-CR-83005 March 1983	"In-Plant Reuse of Pollution Abated Water Phase I - Milan Army Ammunition Plant"
December 1984	"Pilot Plant Studies for Water Reuse Systems Milan Army Ammunition Plant"
ARLCD-CR-84043	"In-Plant Reuse of Pollution Abated Waters Phase II - Milan Army Ammunition Plant"

Summary report, June 85, was prepared by Wayne R. Hierseman, Manufacturing Technology Division, US Army Industrial Base Engineering Activity, Rock Island, IL 61299-7260.

**MANUFACTURING METHODS AND TECHNOLOGY  
PROJECT SUMMARY REPORT  
(RCS DRCMT-302)**

MMT Project 581 4267 titled "Granular Process for Composition B" was completed by the US Army Armament, Munitions, and Chemical Command in March 1985 at a cost of \$194,000.

**BACKGROUND**

This project is a follow-on of the effort to develop a continuous method for the production of granular Composition B. It was planned to use granular Composition B as an alternate fill for Composition A-5. Previous process development (FY77, 78) work under this effort indicated that the dry prilling process was the most advantageous technique for controlling process parameters, product granulation, and bulk density in the final product. The dry prilling of both inert and live Comp B was demonstrated on a laboratory scale by at least three methods; two-fluid nozzle, centrifugal atomizer, and batch water slurry. The centrifugal atomizer was proven to be the most effective.

**SUMMARY**

The objective of this project was to develop the centrifugal (spinning cup) atomizer process further. A goal was established to prill inert Comp B simulant acceptably at rates of 1,500 to 4,500 pounds per hour.

The approach involved the comparison testing of two experimental designs; a bottom drive assembly and a top drive assembly of the spinning cup. The effectiveness of the rotary cup process included determining the capability to obtain production quantities of granulated Composition B. A requirement had been identified for large scale production of granular Composition B to be used in pressloading munitions. The purpose of this development program was to determine technical performance parameters, identify process cost factors, and characteristics of the production process for actual applications.

The characteristic functional performances addressed the ability of the rotary cup process to produce continuously, under steady state conditions, production quantities of granular Composition B that complied with MIL-C-401E. The attributes included in the evaluation and analysis were functional process, material solidification, process continuance, and granular size distribution.

The parameters considered included process feed rates, rotary cup angular speed, rotary cup size and configuration, consistent material uniformity, particle sphericity, particle size distribution, and resultant bulk density.

The test facility for prilling simulated (inert) Composition B was constructed at the contractor, Valimet, Inc. A sketch of the melting container and spinning cup is shown in figure 1. The process was initiated by introducing inert Composition B into the melting unit. As the simulant melted, the agitator paddle was rotated to provide homogeneity of the melt. Attached to the bottom of melting unit drain was a heated valve connecting to a heated downspout.

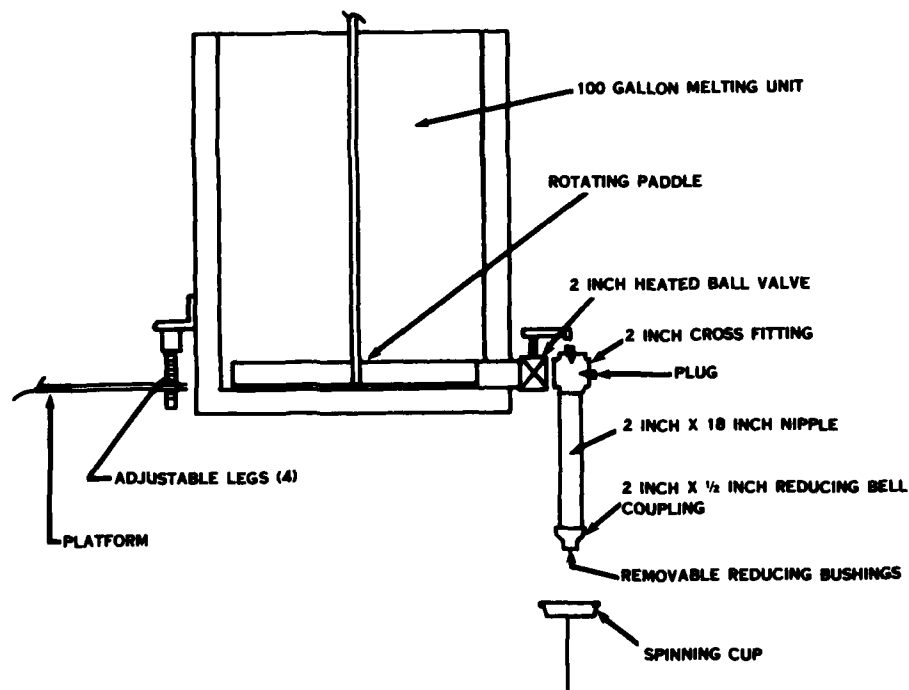

Figure 1 - Melting Container and Spinning Cup

The melting unit was suspended by adjustable legs so that the drop distance to the spinning cup and the drop point on the cup could be varied. The temperature of the simulant was regulated by controls built into the melting unit.

The spinning cup was attached to a vertically mounted motor, such that the driving impetus came from below the cup. The motor was driven by a variable speed motor generator set. Various cup configurations were used for the tests.

The results of the test runs showed that inert Composition B could be successfully atomized using the spinning cup with bottom-drive assembly method. This method produced a continuous processing prilling operation at rates of approximately 3000 pounds per hour. The powder formed was free flowing, spheroidal, and within the particle size ranges required for Composition B.

The actual running of active Composition B could vary from the results obtained from the inert simulant. However, these tests indicated that if homogenous material was delivered to the spinning cup, the powder could be formed at a desirable rate and within the requirements of the specification. Cup speed, flow rate, and drop height should be adjustable to obtain optimum atomizing parameters when designing the production equipment.

Subsequent to the completion of the test runs utilizing a bottom-drive spinning cup assembly, work was accomplished to include a series of tests to centrifugally atomize inert Composition B by means of a spinning cup driven by a top-drive assembly.

The test facility was identical to that used earlier as were the general test procedures. The primary differences were in the design of the spinning cup drive mechanism, the number of test runs, and a lesser number of test parameters.

The results of the test runs indicated that the top-drive assembly method using a stub shaft extension welded to the top center of a spinning cup severely reduces the efficiency of the spinning cup atomizer. If a top-drive mechanism is used, the design must be such that the molten simulant is permitted to impinge on the cup in the center recessed dimple in order to prevent the formation of waves or plumes.

#### **BENEFITS**

This work demonstrated that simulated Composition B can be successfully atomized using the spinning cup with the bottom-drive assembly method. This method produced a continuous processing prilling operation at a rate of approximately 3,000 pounds per hour.

#### **IMPLEMENTATION**

The results of this work were implemented into MMT 582 4267 for the design, construction, and testing of a spinning cup to produce live granular Composition B under contract at Southwest Research Institute.

#### **MORE INFORMATION**

Additional information on this project is available from Mr. J. Van Sciver, ARDC, AV 880-2009 or Commercial (201) 328-2009.

Summary report, June 85, was prepared by Pete Martin, Manufacturing Technology Division, US Army Industrial Base Engineering Activity, Rock Island, IL 61299-7260.



**MANUFACTURING METHODS AND TECHNOLOGY  
PROJECT SUMMARY REPORT  
(RCS DRGHT-302)**

MMT Project 583 4298 titled "Evaluation of DMN Disposal on Holston AAP B-line" was completed by the US Army Armament, Munitions, and Chemical Command in October 1984 at a cost of \$295,000.

**BACKGROUND**

Previous work began to develop the technology for the abatement of dimethylnitrosamine (DMN), a carcinogen present in the wastewater stream at Holston AAP (HSAAP). The FY82 project provided the process design for the catalytic hydrogenation of the final sludge stream to dispose of the DMN. A drawing package and materials list was prepared to permit the procurement of processing equipment, piping, instrumentation, and installation materials required to construct a functional DMN disposal facility at HSAAP. In addition, work continued on investigation of a semi-continuous activated sludge treatment system for treating munition wastewaters.

**SUMMARY**

The objective of this project was to complete the effort by procuring the equipment for the DMN disposal facility at HSAAP. Also, the work on evaluating a semi-continuous sludge treatment system was to be completed.

The DMN disposal system design was prepared on the basis of installing and operating the system as a pilot plant facility at building B-3 in the B-line at HSAAP. The design was detailed in a drawing package consisting of drawings and the supporting materials list. The pilot plant design permitted the new catalytic hydrogenation process to be evaluated and, if necessary, modified without disrupting current B-line operations. The system was sized to handle the total amount of final sludge generated from the acetic acid recovery operation of a small sized B-building. This full-scale sizing, coupled with the operational flexibility of the pilot plant design, will make the DMN facility readily adaptable to production usage after system proveout has been completed.

Since the DMN disposal system was designed to eliminate DMN and explosives from the final sludge stream at building B-3, some of the existing equipment at or near building B-3 will be used to support the pilot plant evaluation. This includes one acetic acid stripping column, three final sludge storage tanks in the tank farm, two reactor feed pumps used to feed final sludge into the caustic reactors, one caustic reactor used as a finished sludge hold-up and transfer tank, and one transfer pump. The new process equipment which was

purchased includes a sludge feed tank, two-stage centrifugal pump system, catalytic hydrogenation reactor, vapor-liquid separator, finished sludge hold-up tank, and finished sludge transfer pump.

The equipment procurement, instrumentation, and piping for the DMN disposal system was initiated under this project. The final procurement and installation actions will be completed under MMT Project 58X 4511, "Disposal of Final Sludge from Acid Recovery Operations."

The contracted effort at George Washington University to evaluate the use of a semi-continuous activated sludge treatment system for treating munition wastewaters was completed. A synthetic waste stream simulating Holston AAP's waste effluent was used for this evaluation. The reactor design, construction, and testing were completed. A diagram of the reactor system is shown in figure 1.

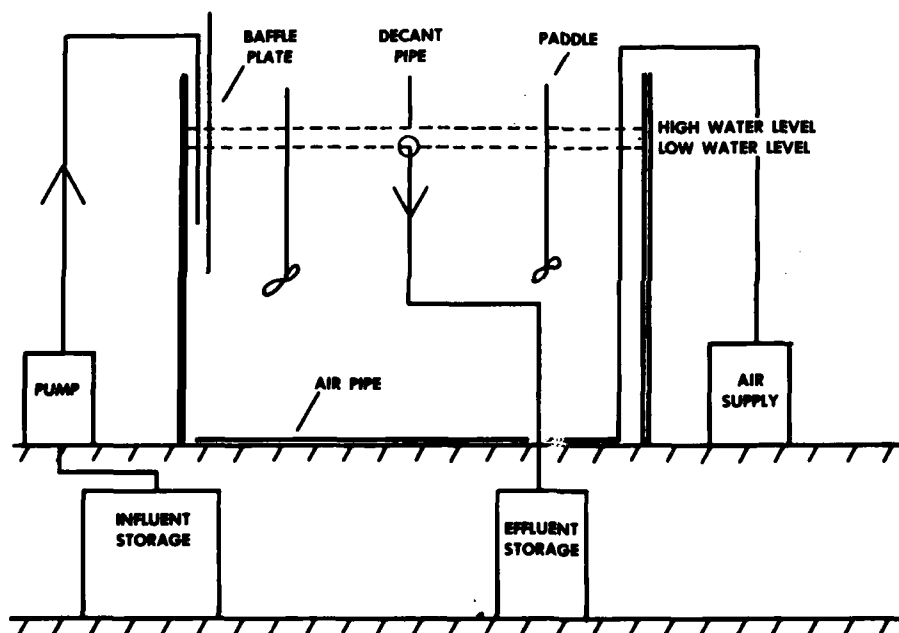

Figure 1 - Schematic of Experimental Reactor

In this system, wastewater was continuously fed to an intermittently operated reactor. The reactor was aerated for a period of time. The air was then turned off and the contents of the reactor allowed to settle. After settling, the reactor was decanted and the cycle repeated. The operation sequence was varied to include a period where mixing was provided but aeration was not. Under these conditions, an anoxic environment was created where denitrification took place using the organic matter in the incoming wastewater

as the carbon source. Changing the timing of any portion of the cycle allowed the operational flexibility of varying detention times in any portion of the process to meet the variation in load or wastewater characteristics. In this way, consistent effluent quality could be maintained under varying loadings. A major advantage of the system was that effluent quality could be loosely monitored prior to discharge.

The bench-scale semi-continuous activated sludge system was acclimated to a synthetic munitions wastewater containing the following constituents: RDX, HMX, TNT, water, nitromethane, formaldehyde, sodium phosphate, calcium sulfate, acetic acid, hexamine, cyclohexanone, 1-propanol, n-propyl acetate, methyl amide, dimethyl amide, toluene, stearic acid, acetone, methyl acetate, and formic acid. This wastestream simulated the waste effluent from the Industrial Liquid Waste Treatment Facility at Holston AAP. Studies were conducted over a period of 30 months with the experimental reactor system.

The system proved to be extremely stable and easy to operate. Organic removals reached almost 100% biodegradable COD removal and were consistently in excess of 95%. Complete nitrification and denitrification were consistently achieved. Solids, separation, and sludge settleability were excellent. Partial removals of RDX and HMX were achieved. DMN was neither formed nor removed during the operation of the system. TNT removal was complete, and despite intensive efforts to find them, no metabolites or degradation products of TNT were found in either the effluent or sludge.

#### **BENEFITS**

This project provided the basic process equipment for the DMN pollution abatement facility at HSAAP. In addition, a semi-continuous activated sludge treatment system was developed and tested successfully for the treatment of munitions wastewater.

#### **IMPLEMENTATION**

The equipment procured under this project will be installed and tested under MMT Project 58X 4511, "Disposal of Final Sludge from Acid Recovery Operations." The effort on the semi-continuous activated sludge treatment system will be continued under Value Engineering Project 583 3046, "Improved RDX/HMX Wastewater Treatment Facility."

#### **MORE INFORMATION**

To obtain additional information, contact the project officer, Mr. J. Swotinsky, AV 880-3544 or Commercial (201) 328-3544.

Summary report, June 85, was prepared by Pete Martin, Manufacturing Technology Division, US Army Industrial Base Engineering Activity, Rock Island, IL 61299-7260.

**MANUFACTURING METHODS AND TECHNOLOGY  
PROJECT SUMMARY REPORT  
(RCS DRCMT-302)**

MMT Project 583 4453 titled "Determination of Spacing of Munition Items to Prevent Propagation" was completed by the US Army Armament, Munitions, and Chemical Command in October 1984 at a cost of \$213,000.

**BACKGROUND**

This project is a continuation of a multi-year effort to develop safety criteria that can be used as a basis for the design of all future explosive, load, assemble, and pack (LAP) facilities. As an integral part of the program, the Army Armament Research and Development Center (ARDC) is engaged in the development of safety criteria which includes the establishment of safe separation (nonpropagation) distances. The prior year's efforts were carried out under MMT 581 4288 and consisted of studies to determine the safe separation distances for 30mm M789 HEDP projectiles, 25mm M792 HEI-T cartridges, and M74 AP/M75 AT-AV mines.

**SUMMARY**

The objectives of this program were to establish the safe separation (nonpropagation) distance criteria for the cloud detonator (XM130 SLUFAE Rocket) and the BLU-97/B submunition. The following paragraphs provide examples of work accomplished on them:

Cloud Detonator for XM130 SLUFAE Rocket

Since the presently planned LAP operations at Hawthorne AAP for the XM130 SLUFAE Rocket system (and thus its subcomponents) were for a low volume, hand assembly sequence, the safety testing for the cloud detonator was based on the use of a standard three-bay loading table. Two series of tests were configured: (1) a standard safe separation (nonpropagation) distance test sequence to determine how far apart the cloud detonators should be kept, and (2) a test sequence to insure the structural integrity of the walls between the assembly table loading bays.

For each test layout, one donor and two acceptor cloud detonators were arrayed in a straight line and raised off the ground to simulate the average standoff distance of the assembly table (or conveyor system) above the building floor. The enter specimen served as the donor, or initiated cloud detonator, while the cloud detonators on either side served as the acceptor

specimens, thus producing two acceptor sets of test data results for each test donor detonated. During the exploratory test phase, and within the single test firings, the test separation distance between the donor and acceptor cloud detonators was varied from test to test. However, during the confirmation test phase, the donor-to-acceptor separation distance was always held constant.

In all cases where the donor cloud detonators were simulated, they were primed and initiated with an engineer's special J2 blasting cap without using a boosting charge. The blasting cap, in all cases, was inserted in the firing well provided in the simulated cloud detonators. When fully assembled cloud detonators were used as donors, as in the assembly table structural integrity tests, the nose end was primed with the same engineer's blasting cap but containing a booster of 15 g (0.45 oz) of C4 explosive. These methods of initiation insured that the donor specimen always detonated to a high order explosion, which was further conformed by the examination of the steel witness plates after detonation.

It was concluded from the results of the cloud detonator nonpropagation test program for the XM130 SLUFAE that the 122.0 cm (48.0 in) safe separation spacing between cloud detonators sufficiently deters the potential propagation of an unexpected explosive incident. With this arrangement, the probability of an explosive incident was 7.11% at the 95% confidence level.

In addition, a 1.27 cm (0.5 in) thick steel wall between work stations of the assembly table was sufficient to protect adjacent operators from accidental detonation fragments.

#### BLU-97/B Submunition

A test program was implemented to determine the safe spacing distance for various BLU-97/B submunition LAP facilities under simulated loading plant conditions. The spacing distance was established so that the effects of a major accidental detonation during manufacture would be limited to the immediate area or loading bay and would not be propagated to the adjacent loading activities with catastrophic results. These separation distances were measured in two ways: (1) edge to edge from the bodies of the nearest submunitions between pallets containing 16 submunitions and (2) centerline to centerline on the individual submunitions.

During each test phase, the general test array consisted of a centrally located donor and two acceptors, one on each side of the donor. (figure 1) The specimens, either pallets or single submunitions, were raised above the surrounding terrain to simulate the average height of an assembly line off the loading building floor. This configuration produced two sets of acceptor test data results for each donor detonation initiated. The separation distances between the donor and acceptor specimens were varied during both exploratory and individual tests. However, this distance was held constant throughout the entire series of confirmatory tests.

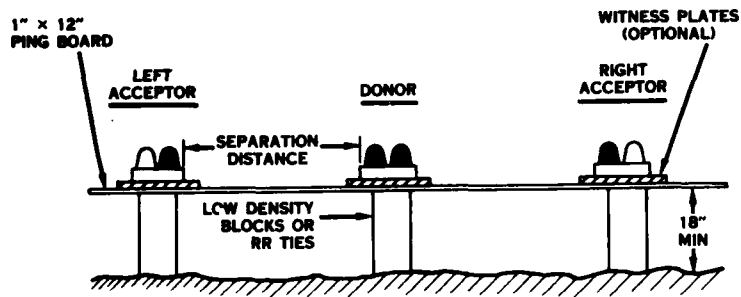

Figure 1 - Submunition Test Array

The test plan involved four phases of testing. Phases 1 and 2 included pallets of 16 submunitions separated by a barrier allowing airflow and a solid barrier, respectively. Phases 3 and 4 included single submunitions separated by a 9.5 cm (3.75 in) high barrier and a full height barrier, respectively. The following results were obtained for the test phases:

- (a) Phase 1 - A separation distance of 1.54 m (5.0 ft) was established for pallets of 16 submunitions separated by an airflow barrier.
- (b) Phase 2 - A separation distance of 1.33 m (4.0 ft) was established for pallets of 16 submunitions separated by a solid barrier.
- (c) Phase 3 - A separation distance of 22.9 cm (9.0 in) was established for single submunitions separated by a 9.5 cm (3.75 in) high barrier.
- (d) Phase 4 - A separation distance of 22.9 cm (9.0 in) was established for single submunitions separated by a full height barrier.

**BENEFITS**

This project developed new safety criteria which was integrated into safety regulatory documents (DARCOM 385-100) to permit construction of both functional and safe munitions manufacturing facilities. The data generated is derived from realistic testing rather than engineering judgment.

**IMPLEMENTATION**

The safe separation distance data for the BLU submunition was incorporated into the design of the modernization facility project 585 2386 at Kansas AAP.

**MORE INFORMATION**

Additional information on this project is available from Mr. W. Stirrat, AMCCOM (D), AV 880-3828 or Commercial (201) 328-3828.

Summary report, June 85, was prepared by Pete Martin, Manufacturing Technology Division, US Army Industrial Base Engineering Activity, Rock Island, IL 61299-7260.

**MANUFACTURING METHODS AND TECHNOLOGY  
PROJECT SUMMARY REPORT  
(RCS DRCMT-302)**

MMT Project 580 4484 titled "Improved Hi-Speed Waterproofing Applicator for Small Caliber Ammunition" was completed by the US Army Armament, Material and Chemical Command in February 1984 at a project cost of \$126,000.

**BACKGROUND**

The primer lacquer and mouth waterproofing applicator system on the SCAMP primer insert submodule periodically fails to perform as required. At times the primer lacquering system applies insufficient amounts of sealant and the mouth waterproofing system will not apply the sealant over the full 360°. Misapplication of either of the sealants may allow the passage of moisture into the primer or propellant resulting in erratic performance. As part of this system upgrade, a central reservoir will also be integrated into the design.

**SUMMARY**

The purpose of this project was to increase the efficiencies of the primer insert and case mouth sealing systems. The improved design included force feeding of the lacquer sealant to assure consistency of application. Testing of the first prototype system found that the lacquer solvent reacted with the delrin applicator. These applicators were replaced with stainless steel units which performed well. The central reservoir system was designed and has performed well with no significant problems being found. The primer system has been operating for 3 1/2 months with virtually no down time and the mouth waterproofing system has operated for over a year, again, with virtually no down time.

**BENEFITS**

The average filling time for the reservoirs is now 8 minutes which is sufficient for an 8-hour shift. The design goal was not to exceed 10 minutes. The stainless steel applicators have operated over 3 1/2 months without changing. The previous (plastic) tooling required replacin after 8 hours of use.

The new system when used on lines 4 & 5 was performing in the 99.5 percent reliability range.

**IMPLEMENTATION**

The results of this project were self implementing on one SCAMP line at Lake City. Facilities projects have been submitted for implementation on the remaining lines.

**MORE INFORMATION**

Additional information relating to this project can be obtained from the AMCCOM project engineer, Mr. Mark Leng AV 880-3737 or Commercial (201) 328-3737.

---

Summary report, Jun 85, was prepared by H. Weidner, Manufacturing Technology Division, US Army Industrial Base Engineering Activity, Rock Island, IL 61299-7260.



**MANUFACTURING METHODS AND TECHNOLOGY  
PROJECT SUMMARY REPORT  
(RCS DRCHT-302)**

MMT Project 582 4560 titled "Mod Tape-Stiffener Assembly Process, M42/M46 Grenades" was completed by the US Army Research and Development Command in March 1984 at a cost of \$142,000.

**BACKGROUND**

The 155mm and 8-inch Improved Conventional Munitions (ICM) are loaded with many dual purpose grenades. The assembly and loading of these grenades into the ICMs is a labor intensive operation. Although some of the operations are automated, some of the assembly and inspection operations still need to be automated to increase production rates, improve safety to operating personnel, and allow a 100 percent self-inspecting capability.

One of the labor intensive operations in this manufacturing process is the application of tape stiffener assemblies to the grenades. The tape stiffener assemblies are procured as completed assemblies and are shipped to government plants in bulk cartons of several thousand per carton. The removal of individual tapes from the carton and their placement on the grenade's fuze is a hand operation which is slow and requires the services of many operators. If a totally automatic machine could be designed and built to perform these functions, many of the manual operations could be eliminated.

An attempt to design and fabricate such a machine began with MMT Project 576 4338, but technical difficulties and cost growths caused a termination of that effort. This project was funded to complete the development initiated by the original contractor, but this time the work was going to be done by one of the eventual users of the equipment.

**SUMMARY**

The objective of this project was to complete, install, and debug the Tape-Stiffener Assembly (TSA) machine developed under the prior project. The specific functions designed into the TSA machine included the fabrication of the tape assembly, placing it on a fixture, installing a washer, and inspecting the completed assembly. The work was to be performed by Kansas Army Ammunition Plant personnel. When the development of this prototype machine was completed, it was to be proven-out on-line under actual production conditions. A schematic of the equipment layout is illustrated in figure 1.

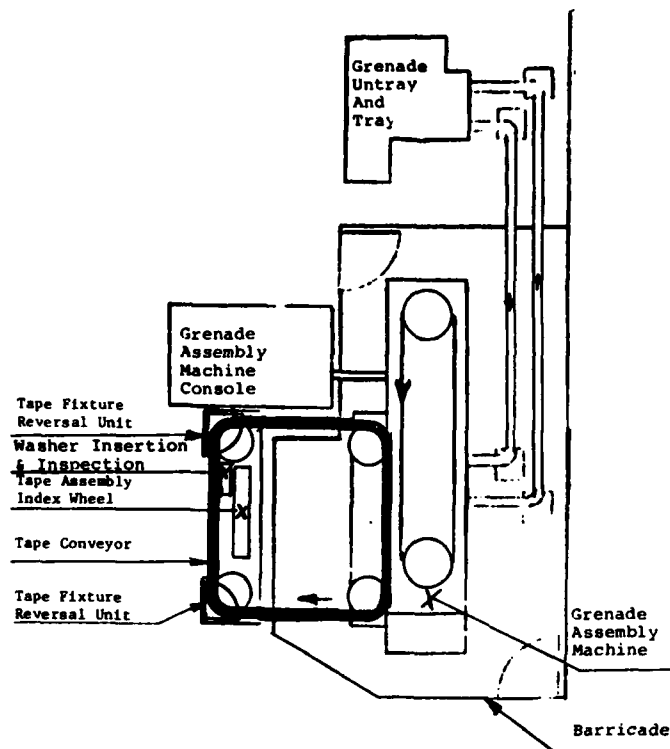

Figure 1 -  
Equipment Layout

Reproducible masters of the mechanical sketches were obtained for Kansas AAP from the contractor who had the original development contract. Three equipment modules had been delivered to Kansas AAP. They were the main dial assembly, an inspection station, and a washer insertion module. The main assembly element was set up off-line for testing, debugging, and modifications. Improvements were made to the control system and the index wheel to improve the tucking operation. Appropriate documentation concerning the off-line operation of the main dial assembly was prepared.

Tape fixture reversal units were fabricated and the installation and interface of the washer insertion and inspection stations were completed. Tapes and stiffeners required for the debugging and RAM/acceptance testing were purchased. Improvements were made in the transfer of the tape assembly from the machine stations to the tape fixtures. Changes were also made to the programmable controller improving the sequential control of the machine. The machine was placed on-line and installation, interfacing, and debugging were initiated in preparation for the RAM/acceptance testing. However, before this testing could be completed, a high priority production order was received and the machine had to be removed from the production line. Nevertheless, data derived during the on-line installation and debugging showed that additional design changes would be required to improve machine operations. It was determined that an additional \$278,000 and nine months development time would be required for these design changes.

As a result of this cost growth, it was decided to terminate this effort. Aiding in this decision was the experience that was gained during the operation of the 30 parts-per-minute grenade assembly machine. When this effort was initially begun, four operators were required to manually place washers and tape assemblies on the tape fixtures. Currently, only two operators are required. Therefore, even upon the successful completion of this effort, only one operator would be replaced, making the economic returns marginal.

#### **BENEFITS**

The benefits expected from this effort have changed since its inception. The number of operators required was reduced from four to two by other means. Cost growths in the effort and preemption of development work by high priority production orders have detracted from the originally expected benefits. The effort has been terminated.

#### **IMPLEMENTATION**

This effort will not be implemented.

#### **MORE INFORMATION**

Additional information on this project is available from Mr. W. Field, ARDC, AV 880-4422 or Commercial (201) 724-4424.

---

Summary report, June 85, was prepared by A. Kource, Manufacturing Technology Division, US Army Industrial Base Engineering Activity, Rock Island, IL 61299-7260.

# NON-METALS

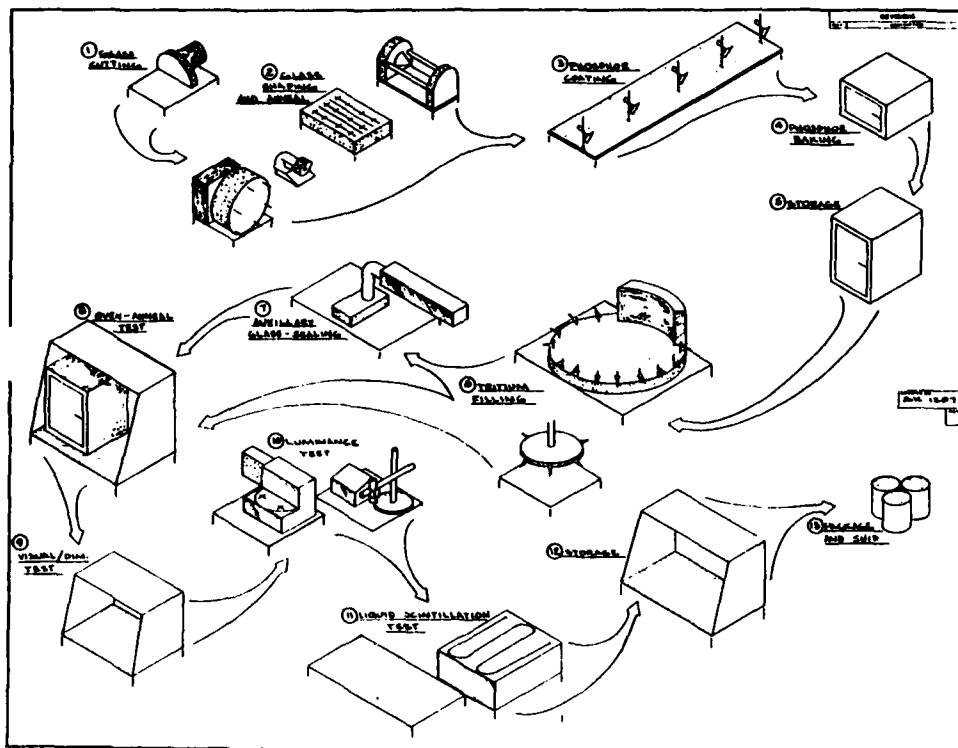

SELF-LUMINOUS LIGHT SOURCE PROCESS

**MANUFACTURING METHODS AND TECHNOLOGY  
PROJECT SUMMARY REPORT  
(RCS DRGHT-302)**

MMT Project 383 1089 titled "Integral Rocket Motor Composite Attachments" was completed by the US Army Missile Command (MICOM) in June 1984 at a cost of \$50,000.

**BACKGROUND**

The propulsion system for the Pershing II missile (figure 1) has three metallic thrust reversal ports on each of its solid fuel rocket motors. Failures have occurred where the metal port attachment ring attaches to the composite motor case causing critical system delays. The attachment rings may be fabricated as an integral part of the case from filament winding material. This can be done by modifying current winding techniques. The method has been successfully proven out on a small scale. However, the method needs to be optimized for production capability.



Figure 1 - Pershing Missiles

## **SUMMARY**

This project is the first of three phases to optimize production capability of rocket motor composite attachments. It encompasses material selection and three-dimensional (3-D) finite element modeling. The contractual work for this effort is being carried out by Hercules Aerospace of Magna, UT, under the guidance of MICOM.

A fiber-resin composite of AS6 graphite and 55A resin was selected for use. This material shows improved performance over the KEVLAR/HBRF-279 system presently in use. It also has a 30 percent improvement in fiber strength over KEVLAR 49 and a 19 percent increase over high strength KEVLAR. Material properties for injection molding and 3-D weave were investigated for use in later phases of this effort.

A 3-D port model developed during the Pershing development program was reactivated for the finite element modeling. Both linear and non-linear static analyses, as well as dynamic analyses, were conducted. Strains tangent to the port were over-predicted by linear analysis and under-predicted by non-linear. The dynamic analysis determined the mode shapes and attempted a transient analysis.

## **BENEFITS**

The AS-6 graphite/55A resin composite system selected will provide improved performance over the previous system. All the information obtained in this phase will be utilized in the next for design optimization.

## **IMPLEMENTATION**

Implementation of these results is dependent on the outcome of two follow-on MMT projects, 384 1089 and 385 1089.

## **MORE INFORMATION**

Additional information may be obtained from Mr. William Crownover, MICOM, AV 746-5821 or Commercial (205) 876-5821. The interim technical report from the contractor is MMT 1089, "Manufacturing Methods and Technology for Integral Rocket Motor Composite Attachments", dated February 1984.

---

Summary report, June 85, was prepared by David Bernreuther, Manufacturing Technology Division, US Army Industrial Base Engineering Activity, Rock Island, IL 61299-7260.

**MANUFACTURING METHODS AND TECHNOLOGY  
PROJECT SUMMARY REPORT  
(RCS DRCMT-302)**

MMT Projects 383 1126 and 384 1126 titled "Wound Elastomer Insulator Process" were completed by the US Army Missile Command (MICOM) in January 1985 at a cost of \$359,000 and \$450,000, respectively.

**BACKGROUND**

Current fabrication methods for rocket motor insulators are costly due to extensive labor and tooling requirements. They also lack design change flexibility and suffer from long lead times. Insulators for large tactical and strategic motors are made by two processes. One process molds and cures the green insulator to final dimensions in precision matched metal molds under heat and high pressure. The insulator is then assembled on the case mandrel and bonded together using splice strips. The other method uses sheets of green stock cut to shape using templates or patterns. The sheets are then layed up on a mandrel, stitched together, and the unit vulcanized. After curing, the insulator must be carefully ground to final dimensions, removed from the mandrel and reassembled on the motor mandrel.

A new method of motor insulator fabrication is that of a wound-elastomeric-insulator (WEI). Under Research & Development funding, this process has been advanced from the fabrication of subscale units to a Pershing II second stage motor.

**SUMMARY**

The goal of this program was to verify the cost effectiveness and versatility of the WEI process. The work was performed by the Bacchus Works of Hercules Aerospace of Magna, UT, under the direction of MICOM.

With the WEI process, a microprocessor controlled winding machine is used to extrude green elastomer to a precisely controlled thickness and immediately wind it directly onto the case mandrel (see figure 1). The insulators' thickness is dependent upon the number of plies of extruded elastomer laid down. The case is then wound directly onto the insulator in the conventional manner. An automated thickness profile measuring system was developed to inspect the uncured insulator. Should the insulator be out-of-tolerance, rework can be done before the motor case is wound. The standard case cure cycle provides an adequate cure for both the casing and the WEI insulator.

Testing of WEI materials resulted in the selection of a insulator which performed equal to, or superior to, the insulator presently being used. A Pershing II first stage case fabricated by WEI was burst tested at

77°F. The burst pressure obtained was the highest ever achieved for this case at this temperature.

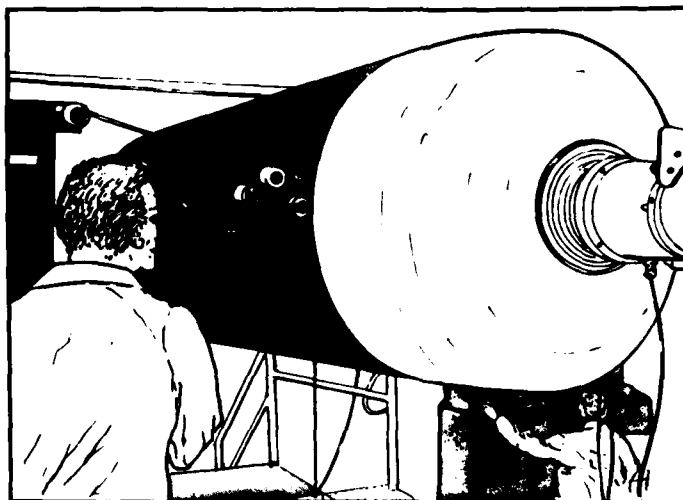

Figure 1 - WEI Process for Making Rocket-Motor Insulators

#### **BENEFITS**

The WEI process provides cost reduction, lead time improvement, and producibility enhancement in motor case fabrication. For the Pershing II program, a savings of \$4.3M will be realized on a \$0.95M implementation cost. The process may be applied to any missile system using a KEVLAR wound filament case as small as 12" to 15" in diameter. Two other DOD missile systems have already been designed to facilitate utilization of the WEI process.

#### **IMPLEMENTATION**

This process is to be implemented in the production of Pershing II motor cases at Hercules Aerospace in fiscal year 1986. It is being investigated for use in several other missile systems.

#### **MORE INFORMATION**

Additional information may be obtained from Mr. Thomas Shaw, MICOM, AV 746-2147 or Commercial (205) 876-2147. The contractors technical report is H241-12-17-002, "Development of a Wound Elastomeric Concept for Solid Rocket Motors", dated September 1984.

Summary report, June 85, was prepared by David Bernreuther, Manufacturing Technology Division, US Army Industrial Base Engineering Activity, Rock Island, IL 61299-7260.



**MANUFACTURING METHODS AND TECHNOLOGY  
PROJECT SUMMARY REPORT  
(RCS DRCMT-302)**

MMT Project 382 3423 titled "Low Cost/High Performance Carbon-Carbon Nozzles" was completed by the US Army Missile Command (MICOM) in September 1984 at a cost of \$500,000.

**BACKGROUND**

Increasing use of tactical missile systems by the Armed Services has created a need for low cost/high performance rocket motor nozzles. Premium 3-D type carbon-carbon materials have thermal and mechanical properties which are well suited for this application. Unfortunately, the cost of these materials is prohibitively high for tactical missiles. Conversely, polycrystalline bulk graphite provides a distinct cost benefit, but its properties are inadequate for this application. A multi-component system is presently being used which provides the necessary physical properties. However, due to the machining and hand lay-up required to fabricate the complex part design, its cost is still high. Two carbon-carbon materials have indicated a potential to provide the necessary physical properties while also being more economic to fabricate.

**SUMMARY**

The purpose of this project was to develop, evaluate, and optimize production techniques for the fabrication of low cost/high performance rocket motor nozzle throats using carbon-carbon materials. The work was performed by Fiber Materials Incorporated, Biddeford, ME, under the direction of MICOM.

Two low cost carbon-carbon materials were investigated: random carbon fibers in a carbon matrix and four directionally (4-D) woven carbon-carbon matrix. Because it lacks continuous fiber reinforcement, the random fiber composites were considered for just small diameter throat configurations. A number of fabrication variations were evaluated before an optimal variation was selected for each of the materials. Pitch fiber (VME) and 15,000 psi pressure-impregnation-carbonation (PIC) were selected for the random fiber composite while P-25 continuous pitch fiber with 15,000 psi PIC was chosen for the 4-D woven matrix.

With both materials, a billet of the material is fabricated from which blanks are cut for individual nozzles (see figure 1). The final shape of the nozzle is then machined from the blank. Large billet fabrication offers cost effectiveness in the areas of manufacturing, quality assurance, and material handling. Producibility and reproducibility are enhanced in that established manufacturing methods are used for preform fabrication and billet densification.

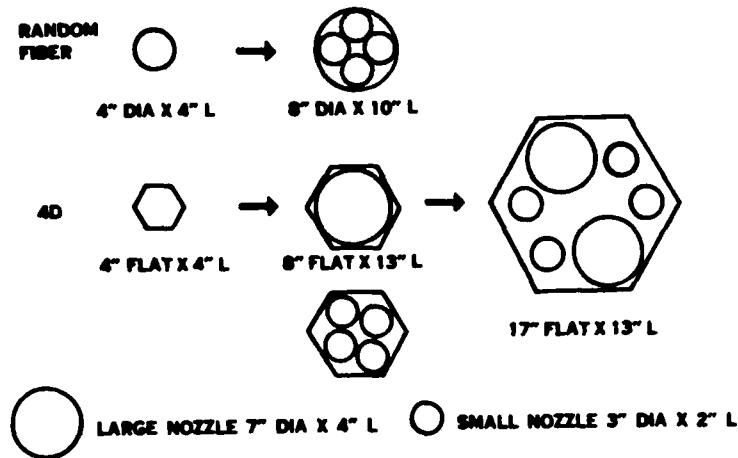

Figure 1 - Carbon-Carbon Billet Configurations

### BENEFITS

This project has provided a cost effective method to produce high performance rocket motor nozzles. The material concepts developed allow material properties to be tailored to a specific application and facilitates design flexibility. This will enhance the implementation of the concepts developed in this project into a number of missile systems.

### IMPLEMENTATION

Implementation plans for this technology are in the process of being prepared by several Department of Defense missile systems.

### MORE INFORMATION

Additional information may be obtained by contacting William Crownover, MICOM, AV 746-5821 or Commercial (205) 876-5821. The contractors technical report is number RK-CR-85-1, "Low Cost/High Performance Carbon-Carbon Nozzles", dated September 1982.

Summary report, June 85, was prepared by David Bernreuther, Manufacturing Technology Division, US Army Industrial Base Engineering Activity, Rock Island, IL 61299-7260.

**MANUFACTURING METHODS AND TECHNOLOGY  
PROJECT SUMMARY REPORT  
(RCS DRCMT-302)**

MMT Projects 476,77,83 5052 titled "Army Engineering Design Handbook for Production Support" were completed by the US Army Management Engineering Training Activity in August 1982 at costs of \$450,000, \$305,000, and \$120,000, respectively.

**BACKGROUND**

Today's technology is changing so rapidly it is becoming increasingly difficult for the design engineer to keep up with the changes. In many instances the design engineer is forced to "re-invent the wheel" due to lack of standard information that would allow him to save design time. The series of AMC Engineering Design Handbook provide references that can supply design engineers and technicians with the information needed to augment their knowledge in such fields as production, inspection, drawings, testing, maintenance, and maintainability.

**SUMMARY**

The purpose of the Engineering Design Handbook is to conserve time, materials, and funds by taking engineering problems and outlining the approaches which are most likely to result in successful solutions. The Engineering Design Handbooks provide fundamental design information not readily available elsewhere. In an effort to preserve unique technical knowledge, the handbooks are constantly being updated with the latest technical information. During the fiscal years covered in this summary, six handbooks were completed and three handbooks are being revised (see Table 1).

TABLE 1

<u>Handbook No.</u>	<u>Title</u>	<u>Status</u>
706-101	Army Weapons Systems Analysis, Part One	Complete
-102	Army Weapons Systems Analysis, Part Two	Complete
-103	Selected Topics in Experimental Statistics with Army Applications	Complete
-122	Quantitative Description of Obscuration Factors for Electro-Optical and Millimeter Wave Systems	Complete
-134	Maintainability Guide for Design	Under Revision
-177	Properties of Explosives of Military Interest	Under Revision
-316	Joining of Advanced Composites	Complete
-317	Continuous Fiber Reinforced Composites	Complete
-342	Recoil Systems	Under Revision

**APPENDIX I**

**ARMY MMT PROGRAM OFFICES**

The life cycle testing of the Li-Al/FeS cells was to be compared with the existing standard used for forklift trucks, i.e., the lead-acid battery. Accordingly, the National Electrical Manufacturers Association (NEMA) standard, which is used to test the lead-acid batteries, provided the basis for testing the Li-Al/FeS cells.

Modifications made as a result of tests resulted in the development of a long-lived cell technology. A group of five cells under test have achieved over 900 cycles in deep-discharge cycling. The mean cycle life projected is considerably higher than 1000 cycles.

#### **BENEFITS**

This program provided additional confirmation of the advantages foreseen for Li-Al/FeS forklift truck batteries. These include 1) doubling or tripling of the vehicles's range, 2) decreased maintenance, 3) improved safety, 4) continuous operation via quick-charge, and 5) equivalent or improved life-cycle cost compared to the present lead-acid batteries.

#### **IMPLEMENTATION**

The BRDC is not pursuing the molten salt technology at this time. However, the Department of Energy is funding such an effort. Hence, BRDC will continue to monitor the battery development for possible inclusion in the mission area.

#### **MORE INFORMATION**

Additional information on this project is available from Alayne A. Adams, BRDC, AV 354-5309 or Commercial (703) 664-5309. Also, Technical Report ANL-84-23 was published by the Argonne National Laboratory in August 1984 entitled "Status of the Lithium-Aluminum/Iron Sulfide Batteries Manufacturing Technology."

Summary report, June 85, was prepared by Wayne Hierseman, Manufacturing Technology Division, US Army Industrial Base Engineering Activity, Rock Island, IL 61299-7260.

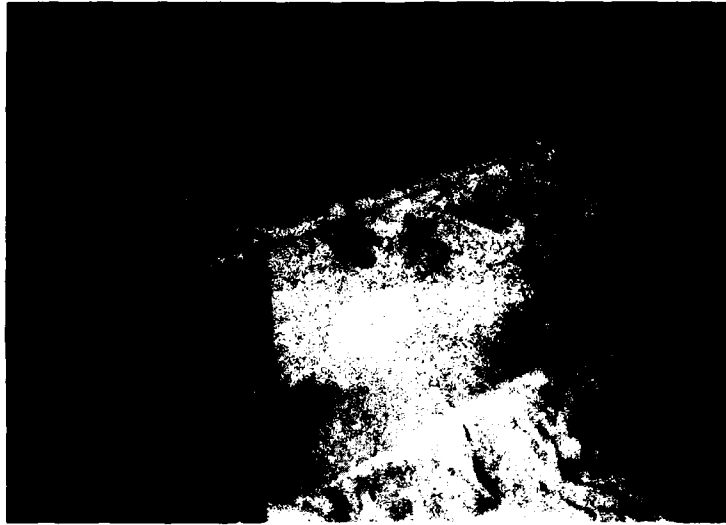

Figure 2 - View of 30-Cell Battery Case

It employs an insulating case which uses a special high-efficiency thermal insulation. It has a removable top that permits modules to be loaded conveniently from the top. The battery has 60 cells arranged in two levels, with 30 cells per level. The 30 cells are subdivided further into 5 modules of 6 cells each. Each module is contained in an electrically insulated metal tray that provides for the required cell restraint and isolation of each module in case of electrolyte leakage. Within each module, the cells are paired in parallel, and each pair is connected in series within the module, resulting in a module discharge voltage of about 3.6 V. The 10 modules connected in series provide a total nominal battery voltage of 36 V. They are expected to deliver greater than 48 KWH at the 6-hour rate.

A lithium-aluminum/iron sulfide (Li-Al/FeS) cell must operate at a temperature that is above the melting point of the molten salt electrolyte. For this reason, the battery must be initially heated to, and held at, an operating temperature of approximately 460°C for continued operation.

As is shown in figures 1 and 2, the insulated top has an interlocking edge that provides a sealing surface for a hermetic seal. Heating and cooling of the cells are provided by a heat exchanger that uses ambient air for cooling and electrical resistance heaters for heating. The heaters are sized to heat the battery to its operating temperature in 16 hours. The heat exchanger features a corrugated construction which provides the required rigidity to support the cell modules.

**MANUFACTURING METHODS AND TECHNOLOGY  
PROJECT SUMMARY REPORT  
(RCS DRMT-302)**

MMT Project E79 3532 titled "Molten Salt Lithium/Chlorine Battery" was completed by the US Army Belvoir Research and Development Center (BRDC) in February 1985 at a cost of \$295,000.

**BACKGROUND**

Research and development work on rechargeable lithium/molten salt batteries has been underway for the past decade. One likely area of potential application is power sources for forklift trucks. Prior MMT work in this area suggested that work be concentrated on a cell with an iron sulfide cathode. The anode should remain a lithium-aluminum alloy and the electrolyte a mixture of lithium chloride and potassium chloride.

**SUMMARY**

The objective of this program was to make improvements in the manufacturing process of molten salt batteries and demonstrate them in an operational forklift.

The design basis for the forklift battery was the space available on an Allis Chalmers ACE 45A Electric Rider Truck. This, as shown in figures 1 and 2, is a space roughly 38.5 in. x 23.5 in. x 27.3 in.

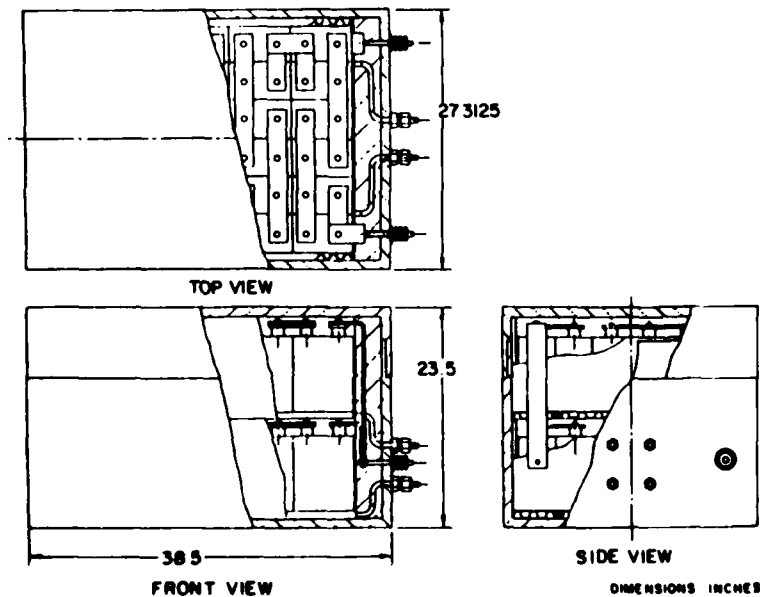

Figure 1 - Battery Layout

## **BENEFITS**

This effort resulted in improvements to the XM30 Mask which included economic and enhanced producibility features coupled with improved inspection procedures. These improvements are estimated at \$20.64 per mask.

## **IMPLEMENTATION**

The improvements for the new protective mask were usable on both the XM30 (now Air Force MCUZP, and in procurement) and the XM40 mask procurements scheduled to start in FY86.

## **MORE INFORMATION**

To obtain additional information, contact the project officer, Mr. H. MacIver, CRDC, AV 584-2937 or Commercial (301) 671-2937.

---

Summary report, June 85, was prepared by Pete Martin, Manufacturing Technology Division, US Army Industrial Base Engineering Activity, Rock Island, IL 61299-7260.



The material finally approved for XM30 mask fabrication was a Dow Corning unpigmented silicone. This material was selected because it could be bonded to the urethane lens. The material was tacky and necessitated revising the faceblank injection mold to a transfer mold to make satisfactory parts.

Three sizes of molds were built for the polyurethane lens and a standard injection machine was procured for its operation. Polyurethane material was purchased from Mobay Chemical Corporation. Some difficulties were encountered in making lens because some batches of material were contaminated with long strands of extruded stock. Processing the material was also a problem as the mold release agent in the material left a residue on the mold surface. The result was a hazy lens if it was not removed by wiping the mold each cycle. Despite these problems, a lot of 250 lens were produced in a production run with good results and an 89 percent yield.

By an amendment to the contract, MSA was tasked to provide a lens bonding system. Initial development pointed to a simple process using Goodyear 4001/4002 adhesive. Tooling and equipment were built to produce bonds to the process established. In the XM30 contoured configuration, however, the process did not prove satisfactory. Directives from CRDC were to duplicate a Sierra Co. process. This included plasma treating, priming, the use of Synthetic Systems 34D adhesive and the Dow unpigmented silicone. Satisfactory results were still not obtained, however, until a bladder type fixture was built that could apply a uniform pressure to the assembly. A lot of 50 assemblies did pass the 18-week environment storage test.

A further modification to the contract was to provide complete tooling for the XM30, 33 and 34 mask including 1600 assemblies. Complete tooling, with the exception of packaging tooling, was built along with test equipment and make-ready of facilities. Later modifications to the contract substituted bonding studies in lieu of most of the complete assemblies. In addition, a physical configuration audit was added instead of first article testing.

As a result of this contract, a set of tooling was built by MSA that would support production of 1000 masks per month. Despite the availability of tooling and the technical data package, some problems remained that could impact on manufacturability. These included producibility of the lens and obtaining satisfactory lens bonds. Manufacturing the lens was of primary concern because of material non-uniformity and availability. Lens bonding procedures were established that produced acceptable assemblies. Test methods, however, were either subjective or destructive.

The efforts on developing test equipment were stopped in June 1982 and the pilot testing was held to a minimum. On July 1982, DA decided not to type classify the new protective mask but to complete these MMT projects. The Army did not accept the XM30 mask for field use, but the mask will be utilized by the Navy and Air Force.

**MANUFACTURING METHODS AND TECHNOLOGY  
PROJECT SUMMARY REPORT  
(RCS DRGHT-302)**

MMT Projects 580, 81, and 82 1335 titled "Manufacturing Techniques for New Protective Mask" were completed by the US Army Armament, Munitions, and Chemical Command in December 1983 at total costs of \$1,574,000, \$2,575,900, and \$1,000,000, respectively.

**BACKGROUND**

These projects are a continuation of a multi-year effort to provide a pilot facility for evaluating the manufacturing processes for the XM30 New Protective Mask. During FY78 and FY79, a manufacturing plan identifying the equipment and tooling requirements was accomplished. In addition, a DIPEC search was completed.

**SUMMARY**

The main objective of this portion of the effort was to provide a pilot facility with the necessary machinery, tooling and test equipment and prove-out the process to produce the mask.

Mine Safety Appliances Company (MSA) was awarded a contract in May of 1980 for the design and fabrication of a rubber molding system consisting of presses, molds and related controls for the XM30 faceblank, nose cup, and lens. The program objective was to use basic XM29 unimold data and design a two-piece mask (periphery and lens) incorporating a biradial "barrel" shaped lens instead of the unimolded ellipsoid shaped lens.

The XM29 data was in the form of steel faceblank molds and Devcon nose cup models. These were found not to be symmetrical from the right to the left side. To correct this condition, an amendment was issued to the contract for MSA to provide waterline drawings of the faceblank and nose cup in order that symmetrical molds could be constructed. The XM30 faceblank and nose cup molds were built by duplicating models based on XM29 data.

Various materials were molded into faceblanks:

- ° Silicon (3 types)
- ° Hydrin
- ° Nitrile/Rubber
- ° Butyl

During this initial phase of the protective mask effort, in-process reviews were held, and, as a result, design changes and rescheduling of milestones were necessary. One of the major changes in the direction of the project was that the entire MMT effort was transferred to industry and would not be planned for an in-house pilot plant.

A contract was awarded to Mine Safety Appliances Company (MSA) in April 1980 for the procurement and set-up of processes, molds and controls for the pilot plant. A modification to the contract was made in April 1981 to conduct the effort on lens bonding automation. The results of the contractors' efforts are to be completed and reported during the project years initially funded in FY80, 81, and 82.

#### **BENEFITS**

A manufacturing plan was developed for pilot facility manufacturing the new protective mask. Equipment and tooling requirements were identified by the plan.

#### **IMPLEMENTATION**

The information was developed for the equipment and tooling requirements for a future production facility. The purchase, installation and operation of the equipment is programmed in the follow-on projects.

#### **MORE INFORMATION**

Additional information on this project is available from Mr. H. Mac Iver, CRDC, AV 584-2937 or Commercial (301) 671-2937.

---

Summary report, June 85, was prepared by Pete Martin, Manufacturing Technology Division, US Army Industrial Base Engineering Activity, Rock Island, IL 61299-7260

components for the pilot run. This task also included the key element in the MMT project which is an analysis of each assembly sequence and process to attempt to optimize the individual assembly sequences to proceed and insure a smooth operating pilot run.

4. (FY81) Pilot facility completion - This task involved the plant preparation, equipment installation, and pilot line set-up, and included equipment adjustment.

5. (FY81) Pilot operations - This task involved the production of a limited number of masks and a larger pilot run of selected components to demonstrate the operations capability of the pilot facility and to check out the final technical data package and quality control provisions and Description of Manufacture (DOM).

6. (FY82) Acquisition of automated test equipment - This task involved the definition of design concept, preparation of design drawings, fabrication and evaluation of a prototype high-speed automated production test system. The system was to be utilized and proved-out during the pilot production run.

During the FY78 and FY79 project efforts, the manufacturing plan identifying equipment and tooling required was developed. The plant layout and DIPEC search were also completed. A schematic drawing of the typical in-house plant layout is shown in figure 1. The two major areas shown are the mask/facepiece area and the aerosol filter area.

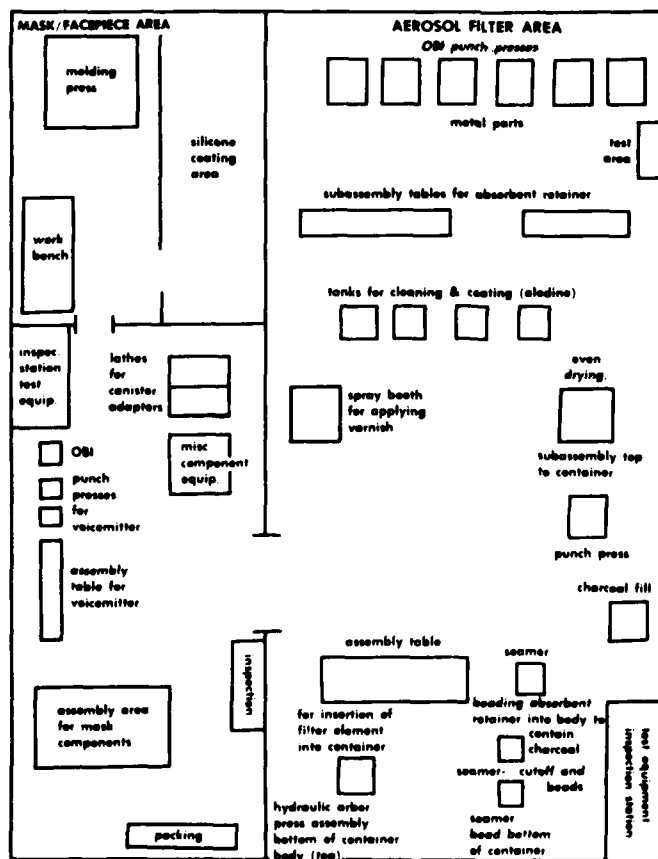

Figure 1 - P-T Line - XM30 New Protective Mask

**MANUFACTURING METHODS AND TECHNOLOGY  
PROJECT SUMMARY REPORT  
(RCS DRCMT-302)**

MMT Projects 578 1335 and 579 1335 titled "Manufacturing Techniques for New Protective Mask" were completed by the US Army Armament, Munitions, and Chemical Command in December 1983 at total costs of \$764,000 and \$1,173,000, respectively.

**BACKGROUND**

The XM30 Series New Protective Mask, in engineering development, was intended to replace all current Army mask systems and certain Navy and Air Force mask systems. The Five-Year Defense Plan (FYDP) of Sep 79 indicated a procurement program in excess of one million masks over a six-year time frame. The mask was designed with a large optically clear flexible lens area which, for the first time, provided operational compatibility with modern optical fire control and sighting equipment. The lens was to be produced in a single molding operation and bonded to a molded facepiece. Based on knowledge gained during the producibility engineering and planning (PEP) effort, serious manufacturing problems were anticipated in the facepiece - lens bonding operation. Similarly, molding of the facepiece and lens in order to prevent leaks and unacceptable vision reduction and distortion was expected to be difficult. Inspection equipment was to be automated to meet maximum anticipated production rates of 3500-4000 masks per day and to minimize both initial equipment cost and cost of inspection masks during production. Therefore, an extensive pilot process engineering effort was planned to establish mass production technology to produce the new protective masks.

**SUMMARY**

The major objective of this effort was to provide a pilot facility with the necessary machinery, tooling, and test equipment for producing the new protective mask. The complete program encompassed six subtasks, as follows, for the FY78 through FY82 time period.

1. (FY78, 79) Procurement of molds and presses - This task included a survey of DIPEC for usable equipment and preparation of a contract to purchase and install three presses and nine molds (three lens molds, three periphery molds, and three nose cup molds).

2. (FY80) Automatic lens bonding - Procedures for the bonding of the lens to faceblank was defined and optimized and an automated system fabricated and used during the pilot run.

3. (FY80) Process/tool engineering - This task involved the definition of component assembly procedures and the necessary tooling to produce the

Table 1 - Material and Process Combination Rating

M&P COMBINATION		CRITERION						COMBINATION RATING
		UNIT COST	PERFORMANCE	RELIABILITY	DEVELOPMENT COST	TECHNOLOGICAL RISK	AVAILABILITY OF TECHNOLOGY	
1	300 S. Steel, Photo Etch, CNC, Electro Plate Vacuum Furnace Bond	1	10	10	10	10	10	330
2	400 S. Steel, Laser Mach, CNC, Electro Plate Vacuum Furnace Bond	8	9	10	9	9	10	380
3	Nickel, Laser Mach, CNC, Clad Metal Conventional Furnace Bond	10	7	9	3	8	9	359
4	Mild Steel, Fine Blank; Vacuum Sinter Adhesive Bond - Furnace Cure	8	5	5	5	5	6	244
5	300 S. Steel, Vacuum Sinter, Laser Mach Fine Blank, Braze Preform, Vac. Fur. Braze	3	6	8	4	6	6	226
6	Titanium, Fine Blank, CNC Static Diffusion Bond	10	8	8	6	7	7	335
7	S. Steel-Nickel, EDM-CNC, Laser Mach Fine Blank, Ceramic, HIP	9	6	6	4	4	5	256
8	Nickel, Laser Mach, Photo Etch, CNC Clad Metal, Conv. Furnace Bond	10	7	9	9	8	8	361
9	300 S. Steel, EDM-CNC, Laser, CNC Braze Preform, Vacuum Furnace Braze	2	6	8	7	7	7	243
10	Plastic, Laser, CNC Adhesive Bond-Furnace Cure	8	3	3	3	3	4	180

**BENEFITS**

The redesign of FD components to take advantage of specific volume production techniques can further reduce component costs. The application of CNC machine techniques can reduce the cost of the rod guide, base cup, and the diffuser ring by an average of 87 percent. Several material and process combinations have been identified which have the potential to reduce FJV production costs by approximately 75 percent. Upon completion of field testing, life cycle cost verification and performance improvement documentation, the overall cost advantage of the fluidic damper will be readily apparent.

**IMPLEMENTATION**

During FY85, work on this task will be continued with Phase II. This will include the fabrication of sufficient quantities of fluidic dampers to optimize the fabrication process. An economic analysis will be conducted and the adequacy of the components will be verified by field testing.

**MORE INFORMATION**

Additional information may be obtained by contacting M. Whitmore, TACOM, AV 786-8675 or Commercial (313) 574-8675. The final TACOM R&D Center Laboratory Technical Report No. 12866 is titled "Material and Process Development for Fabrication of the Fluidic Damper Phase I Technology Assessment" dated August 1983.

Summary report, June 85, was prepared by Robert Hellem, Manufacturing Technology Division, US Army Industrial Base Engineering Activity, Rock Island, IL 61299-7260.

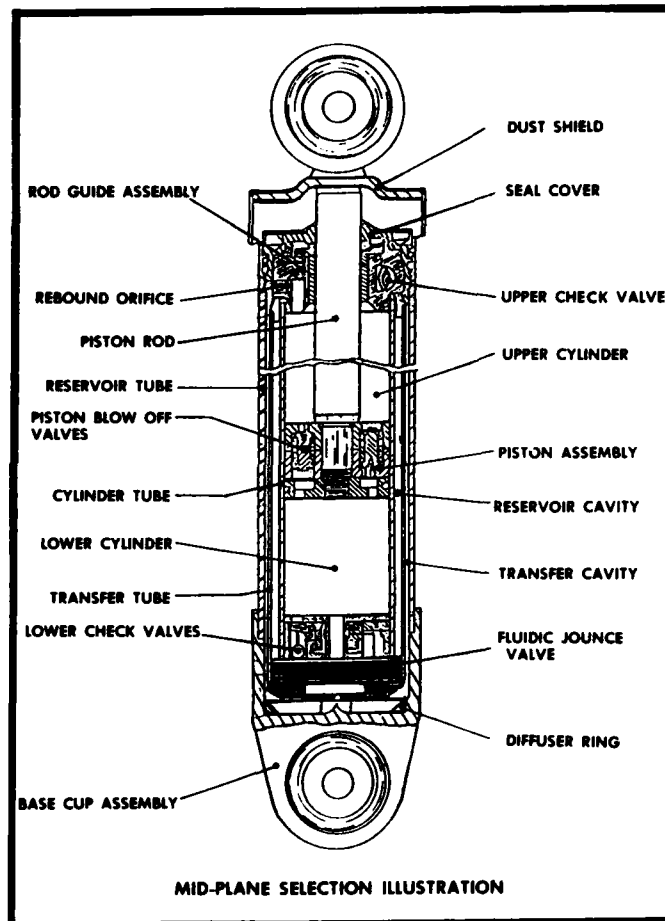

Figure 1 - Fluidic Damper

The initial step in generating the product specification was to analyze the FJV circuit to determine fluid pressure forces at critical locations within the valve. An analysis of the effect of external pressure on the valve was also performed. The resulting sets of data were combined, and a stress analysis was performed to establish material property requirements. These requirements were integrated into key FJV assembly and component drawings to form the product specification.

The availability of suitable materials, fabrication methods and bonding processes for FJV manufacture was investigated by contacting vendors and distributing the product specification. A number of materials and processes may be used for efficient FJV production such as mild steel and adhesives, nickel and laser machining, stainless steel and conventional furnace bonding. Ten material and process combinations were evaluated using a rating system developed specifically for the program. This process provided a relative evaluation of all the combinations in accordance with the criteria established for the rating system. Criterion variable values were determined for each of the ten combinations, and each criterion function value was calculated. The object was to maximize the criterion function so that combinations with higher function values are more desirable. Table 1 summarizes the combination rating process showing each combination, its criterion variable values, and the criterion function values. All efforts were made during the selection process to pick combinations which would explore a wide range of fabrication alternatives. Emphasis was also placed on minimizing tooling cost and technological risk involved in M&P process validation.

**MANUFACTURING METHODS AND TECHNOLOGY  
PROJECT SUMMARY REPORT  
(RCS DRCMT-302)**

MMT Task 483 6107-02 titled "Adaptive Fluidic Damper" was completed by the US Army Tank-Automotive Command in December 1984 at a cost of \$90,000.

**BACKGROUND**

The increased performance of the M1 tank and other tracked combat vehicles has placed an increased demand on the performance of lightweight track components. Advanced materials proven under RDT&E have not seen widespread application in track/suspension due to their high production costs and low volume mass production methodologies. The fabrication techniques used in the development phase were adequate to demonstrate the design but are too costly to be utilized for economical mass production.

**SUMMARY**

The objectives of this task were to identify manufacturing materials and processes (M&P) which may be used to reduce the fabrication costs of special fluidic damper (FD) components and of the fluidic jounce valve (FJV). The objectives were achieved by evaluating all FD components, developing an FJV product specification, surveying vendors and soliciting quotations, rating materials and processes, and selecting material and process combinations for development.

In the FD, the conventional jounce valve is replaced with the FJV which provides the following advantages compared to the conventional damper:

- ° Increased wheel-to-ground contact time.
- ° Improved vehicle stability and handling.
- ° Reduced damper energy absorption and heat build-up.
- ° Increased damper reliability and service life.
- ° Reduced logistics costs.

The primary functional assembly of the FD (figure 1) is the FJV, and it is therefore the focal point of this cost reduction program.

The damper component evaluation indicated that the rod guide, base cup and diffuser ring would have the greatest impact upon cost and performance if they were improved. Component drawings for these parts were distributed to vendors for quantity production quotations. Based on the information received, cost projections were developed to indicate the net savings possible by using automated machine tool fabrication.



The handbooks identified in Table 1 cover a wide range of topics. Handbook 706-103 will be available as a design tool for the physical scientist designing an experiment or the engineer who is working on a Statistical Process Control (SPC) system for a production line. Advanced composites are coming into wider use everyday. Handbook 706-316, the Joining of Advanced Composites, can be a valuable aid to the material design engineer who must deal with dissimilar materials. The range of topics covered in the Engineering Design Handbooks are very diverse. The subjects can be very practical or they can be theoretical such as handbooks 706-101 and -102, Army Weapons Systems Analysis. These handbooks discuss battle tactics and war game strategies.

The Engineering Design Handbooks are available to any engineer or technician interested in improving their designing ability. DOD personnel may obtain the handbooks from the Defense Technical Information Center and non-DOD personnel may obtain the handbooks from the National Technical Information Center. The Engineering Design Handbook program helps Army designers keep up with the latest changes in technology and contributes greatly to the Army's effort to stay on the "cutting edge" of high technology.

#### **BENEFITS**

It is very difficult to put a monetary value on the benefits realized by using the handbooks. If design time can be optimized a savings is realized in engineering design costs. The benefits obtained are dependent on the designer using the handbooks to their fullest capacity.

#### **IMPLEMENTATION**

Upon completion and publication the handbooks are made available for use by all US Army engineers and technicians through the Letterkenny Army Depot.

#### **MORE INFORMATION**

Additional information may be obtained by contacting Paul Wagner, AV 793-4041 or Commercial (309) 782-4041. Also, there is a brochure explaining the program, "U.S. Army Materiel Command; Engineer Design Handbooks, Study and Design," U.S. Armament Management Engineering Training Activity, Rock Island, IL 61299-7260.

---

Summary report, Jun 85, was prepared by Frank Stonestreet Manufacturing Technology Division, US Army Industrial Base Engineering Activity, Rock Island, IL 61299-7260.

ARMY MMT PROGRAM REPRESENTATIVES

Department of the Army

ODCSRDA

ATTN: DAMA-PPM-P/LTC S. Marsh  
Room 3C400, The Pentagon  
Washington, DC 20310

C: (202) 695-0507  
AV: 225-0506

HQ, AMC

U.S. Army Materiel Command  
ATTN: AMCPD-(MT)/Mr. F. Michel  
5001 Eisenhower Avenue  
Alexandria, VA 22333-0001

C: (202) 274-8284/8298  
AV: 284-8284/8298

AMCCOM

U.S. Army Armament, Munitions & Chemical Command  
ATTN: AMSMC-PBS-A (R)/Mr. Carrol Schumacher  
Rock Island, IL 61299-6000

C: (309) 782-3517/3665  
AV: 793-3517/3665

U.S. Army Armament, Munitions & Chemical Command  
Armament Research and Development Center  
ATTN: SMCAR-PMP-P/Mr. Donald J. Fischer  
Dover, NJ 07801

C: (201) 724-6092  
AV: 880-6092

U.S. Army Armament, Munitions & Chemical Command  
Chemical Research and Development Center  
ATTN: SMCCR-PMI/Mr. John Kurtz  
Building E5101  
Aberdeen Proving Grounds, MD 21010

C: (301) 724-3418/3586  
AV: 584-3418/3586/3010

U.S. Army Armament, Munitions & Chemical Command  
Production Base Modernization Agency  
ATTN: AMSMC-PB (D)/Mr. Joseph Taglairino  
Dover, NJ 07801

C: (201) 724-3560/3563  
AV: 880-3560/3563

AMC Intern Training Center

ATTN: AMXMC-ITC-E/Mr. Mickey Carter  
Red River Army Depot  
Texarkana, TX 75507

C: (214) 838-2001  
AV: 829-2001

AMETA

U.S. Army Management Engineering Training Activity  
ATTN: AMXOM-SE/Mr. Paul Wagner  
Rock Island, IL 61299

C: (309) 782-4041  
AV: 793-4041

AMMRC

U.S. Army Materials & Mechanics Research Center  
ATTN: AMXMR-PP/Mr. John Gassner  
Watertown, MA 02172

C: (617) 923-5521  
AV: 955-5521

AMRDL

U.S. Army Applied Technology Laboratory  
Army Research Technology Lab (AVSCOM)  
ATTN: DAVDL-ATL-ATS/J. Waller  
Fort Eustis, VA 23604

C: (804) 878-5921/2401  
AV: 927-5921/2401

AVSCOM

U.S. Army Aviation Systems Command  
ATTN: AMSAV-PEC/Mr. Fred Reed  
4300 Goodfellow Blvd.  
St. Louis, MO 63120

C: (314) 263-3079/3080  
AV: 693-3079/3080

CECOM

U.S. Army Communications & Electronics Command  
ATTN: AMSEL-POD-P-G/Mr. Al Feddeler  
AMSEL-PC-SI-I/Mr. Leon Field  
Fort Monmouth, NJ 07703

C: (201) 535-4926  
AV: 995-4926  
C: (201) 532-4035  
AV: 992-4995

DESCOM

U.S. Army Depot Systems Command  
ATTN: AMSDS-RM-EIT/Mr. Mike Ahearn  
Chambersburg, PA 17201

C: (717) 263-6591  
AV: 238-6591

ERADCOM

U.S. Army Electronics R&D Command  
ATTN: AMDEL-PO-SP/Mr. Harold Garson  
2800 Powder Mill Road  
Adelphi, MD 20983

C: (202) 394-3812  
AV: 290-3812

HDL

Harry Diamond Laboratories  
ATTN: DELHD-PO-P/Mr. Julius Hoke  
2800 Powder Mill Road  
Adelphi, MD 20783

C: (202) 394-1551  
AV: 290-1551

IBEA

U.S. Army Industrial Base Engineering Activity  
ATTN: AMXIB-M/Mr. James Carstens  
Rock Island, IL 61299-7260

C: (309) 782-5113  
AV: 793-5113

MICOM

U.S. Army Missile Command  
ATTN: AMSMI-ET/Mr. Bobby Park  
Redstone Arsenal, AL 35898

C: (205) 876-2147  
AV: 746-2147

RIA

Rock Island Arsenal  
ATTN: SMCRI-ENM/Mr. J. W. McGarvey  
Rock Island, IL 61299-5000

C: (309) 782-4142  
AV: 793-4142

TACOM

U.S. Army Tank-Automotive Command  
ATTN: AMSTA-RCKM/Mr. Donald Cargo  
Warren, MI 48090

C: (313) 574-8709  
AV: 786-6191

TECOM

U.S. Army Test & Evaluation Command  
ATTN: AMSTE-AD-M/Mr. William Deaver  
Aberdeen Proving Ground, MD 21005

C: (301) 278-3677  
AV: 298-3677

TMDE

U.S. Army Test Measurement Diagnostic Equipment Support Group  
ATTN: AMXTM-S/Mr. Ken Magnant  
Redstone Arsenal, AL 35898

C: (205) 876-1850/2575  
AV: 746-1850/2575

TROSCOM

U.S. Army Troop Support Command  
ATTN: AMSTR-PT/Mr. Richard Green  
4300 Goodfellow Blvd.  
St. Louis, MO 63120

C: (314) 263-2878  
AV: 693-2818

U.S. Army Troop Support Command  
Belvoir R&D Center  
ATTN: STRBD-HE/Mr. K. K. Harris  
Fort Belvoir, VA 22060

C: (703) 664-5433  
AV: 354-5433

U.S. Army Troop Support Command  
Natick R&D Center  
ATTN: STRNC-EML/Mr. Ralph Merullo  
Natick, MA 01760

C: (617) 651-4899  
AV: 256-4899

WVA

Watervliet Arsenal  
ATTN: SMCWV-PPI/Mr. William Garber  
Watervliet, NY 12189

C: (518) 266-5319  
AV: 974-5319

**APPENDIX II**

**DISTRIBUTION**

SUMMARY REPORT

AMXIB-MT

DISTRIBUTION:

Department of the Army:

HQDA, OASARDA, ATTN: Mr. William Takakoshi  
HQDA, DCSRDA, ATTN: DAMA-PPM-P/LTC S. Marsh  
HQDA, DCSRDA, ATTN: DAMA-CS/MAJ Eby  
HQDA, DCSRDA, ATTN: DAMA-CSM-P/Mr. John Mytryshyn  
HQDA, DCSRDA, ATTN: DAMA-WSA/LTC Ron Williams  
HQDA, DCSRDA, ATTN: DAMA-WSM/Mrs. Janet Fox  
HQDA, DCSRDA, ATTN: DAMA-WSW/Mr. Jack Lynn

Department of Defense:

OUSDRE (R&AT), ATTN: Dr. Lloyd L. Lehn (2 cys)  
Defense Logistics Agency, ATTN: Mr. Garland Smith

Department of Energy:

Dir, ATTN: DOE/NBL/Mr. Warren McGonnagle

U.S. Army Materiel Command:

Cdr, ATTN: AMCCG  
Cdr, ATTN: AMCDE  
Cdr, ATTN: AMCDMD  
Cdr, ATTN: AMCDMR  
Cdr, ATTN: AMCPD-(MT)/Mr. Fred Michel (10 cys)  
Cdr, ATTN: AMCPP  
Cdr, ATTN: AMCPP-I  
Cdr, ATTN: AMCPP-I/Ms. Mary Brittain  
Cdr, ATTN: AMCTM-S  
Cdr, ATTN: AMXAM-TL/Technical Library  
Deputy Exec Dir for Conventional Ammo, ATTN: AMXED-AL/Mr. Jim Lutterback

U.S. Army Armament, Munitions and Chemical Command:

Cdr, ATTN: AMSMC (D)  
Cdr, ATTN: AMSMC-LCA-G (D)/Mr. Tony Beardell  
Cdr, ATTN: AMSMC-PB (D)/Mr. Joseph Taglairino (5 cys)  
Cdr, ATTN: AMSMC-PBM-EP (D)/Mr. Dave Fair  
Cdr, ATTN: AMSMC-QAH (D)/Mr. George DeMassi, Mr. George Drucker  
Cdr, ATTN: AMSMC-CG (R)  
Cdr, ATTN: SMCAR-ESP-L (R)/Technical Library (3 cys), [Defense Technical Information Center, ATTN: DDR-1 (2 cys)]  
Cdr, ATTN: AMSMC-LEP (R)/Mr. Bolton (6 cys)  
Cdr, ATTN: AMSMC-PBS-A (R)/Mr. Carrol Schumacher (2 cys)  
Cdr, ATTN: AMSMC-QAK (R)/Mr. Richard Fer  
Cdr, Plastics Technical Evaluation Ctr., ATTN: Harry Pebly  
PM, Tank Main Armaments Systems, ATTN: AMSMC-TMA (D)

U.S. Army Armament, Munitions and Chemical Command - Armament R&D Center:

Cdr, ATTN: SMCAR-PMP-P/Mr. Donald J. Fischer (8 cys)  
Cdr, ATTN: SMCAR-TSS/Technical Library (2 cys)  
PM, Cannon Artillery Weapons Systems, ATTN: AMCPM-CAWS

AMXIB-MT

DISTRIBUTION (Cont'd):

U.S. Army Armament, Munitions and Chemical Command - Chemical R&D Center:

Cdr, ATTN: SMCCR-PMI/Mr. John Kurtz, Mr. Joe Abbott (2 cys)

Cdr, ATTN: SMCCR-CLY-T/Technical Library

U.S. Army Aviation Systems Command:

Cdr, ATTN: AMSAV-G

Cdr, ATTN: AMSAV-PEC/Mr. Fred Reed

Cdr, ATTN: AMSAV-QE/Mr. A. Spratt

Cdr, ATTN: Technical Library

PM, Advanced Attack Helicopter, ATTN: AMCPM-AAH

PM, Blackhawk, ATTN: AMCPM-BH

PM, CH-47 Mod. Program, ATTN: AMCPM-CH47M

U.S. Army Ballistic Research Lab:

Dir, ATTN: AMXBR-BL (A)

Dir, ATTN: AMXBR-TSB-S (A)

U.S. Army Belvoir R&D Center:

Cdr, ATTN: STRBD

Cdr, ATTN: STRBD-HE/Mr. K. K. Harris (3 cys)

Cdr, ATTN: Technical Library

U.S. Army Communications & Electronics Command:

Cdr, ATTN: AMSEL

Cdr, ATTN: AMSEL-PA-M/Mr. C. Faulkner

Cdr, ATTN: AMSEL-PC-SI-I/Mr. Leon Field

Cdr, ATTN: AMSEL-POD-P-G/Messrs. Feddeler, Esposito, Resnic (1 cy ea)

Cdr, ATTN: RD&E Technical Documents Center

U.S. Army Depot System Command:

Cdr, ATTN: AMSDS

Cdr, ATTN: AMSDS-QM/Mr. T. Wolf

Cdr, ATTN: AMSDS-RM-EIT/Mr. Mike Ahearn (2 cys)

U.S. Army Electronics R&D Command:

Cdr, ATTN: AMDEL

Cdr, ATTN: AMDEL-PA/Mr. J. Goon

Cdr, ATTN: AMDEL-PO-SP/Mr. Harold Garson

Cdr, ATTN: DELET-R/Messrs. Key, Reich (2 cys ea)

Cdr, ATTN: DELEW-ES-PE/Mr. Al Bohnert

U.S. Army Materials and Mechanics Research Center:

Dir, ATTN: AMXMR, AMXMR-M (1 cy ea)

Dir, ATTN: AMXMR-EO/Dr. Morton Kliman

Dir, ATTN: AMXMR-PP/Mr. John Gassner

Dir, ATTN: AMXMR-STQ/Mr. Paul Rolston

U.S. Army Missile Command:

Cdr, ATTN: AMSMI

Cdr, ATTN: AMSMI-ET/Mr. Bob Austin, Mr. Bobby Park (5 cys)

Cdr, ATTN: AMSMI-IDB/Mr. Charles Laney, Jr. (4 cys)

Cdr, ATTN: AMSMI-RST/Mr. L. Chapman

Cdr, ATTN: RSIC/Documents

Cdr, ATTN: RSIC/Magazine Room

AMXIB-MT

DISTRIBUTION (Cont'd):

U.S. Army Natick R&D Center:

Cdr, ATTN: STRNC  
Cdr, ATTN: STRNC-EML/Mr. Ralph Merullo  
Cdr, ATTN: AMXTM-TRL/Technical Library

U.S. Army Tank-Automotive Command:

Cdr, ATTN: AMSTA  
Cdr, ATTN: AMSTA-EB/Ms. Vivian Buarkhalter  
Cdr, ATTN: AMSTA-QAT/Mr. F. Braun  
Cdr, ATTN: AMSTA-RCKM/Mr. Don Cargo (5 cys)  
Cdr, ATTN: Technical Library  
PM, Fighting Vehicle Armament, ATTN: AMCPM-FVA  
PM, M-1 Tank System, ATTN: AMCPM-GCM

U.S. Army Test and Evaluation Command:

Cdr, ATTN: AMSTE  
Cdr, ATTN: AMSTE-AD-M/Mr. William Deaver (3 cys)

U.S. Army Troop Support Command:

Cdr, ATTN: AMSTR  
Cdr, ATTN: AMSTR-PT/Mr. Richard Green (3 cys)  
Cdr, ATTN: AMSTR-Q/Mr. W. Creel

Aberdeen Proving Ground:

Cdr, ATTN: STEAP-MT-M/Mr. J. L. Sanders  
PM, Smoke/Obscurants (SMOKE), ATTN: AMCPM-SMK

Watervliet Arsenal:

Cdr, ATTN: SMCWV-CO (2 cys)  
Cdr, ATTN: SMCWV-ODP/Mr. Joseph Baran  
Cdr, ATTN: SMCWV-PPI/Mr. William Garber (3 cys)  
Cdr, ATTN: SMCWV-PPI/Mr. R. MaCabe  
Cdr, Benet Wpns Lab, ATTN: AMSMC-LCB-S/Dr. F. Heiser (3 cys)  
Cdr, Benet Wpns Lab, ATTN: AMSMC-LCB-SE/Mr. Gary Conlon  
Cdr, Benet Wpns Lab, ATTN: AMSMC-LCB-TL/Tech Library

Arsenals:

Cdr, Pine Bluff Arsenal (PBA), ATTN: SMCPCB-CO (2 cys)  
Cdr, Rock Island Arsenal (RIA), ATTN: SMCRI-CO (2 cys)  
Cdr, Rock Island Arsenal (RIA), ATTN: SMCRI-ENM/Mr. J. W. McGarvey (2 cys)  
Cdr, Rocky Mountain Arsenal (RMA), ATTN: SMCRM-IS (2 cys)

Army Ammunition Plants:

Cdr, Crane AAA, ATTN: SMCCN, SMCCN-QAM-C/Mr. S. R. Caswell  
Cdr, Hawthorne AAP, ATTN: SMCHW-CO  
Cdr, Holston AAP, ATTN: SMCHO-CO  
Cdr, Indiana AAP, ATTN: SMCIN-CO  
Cdr, Iowa AAP, ATTN: SMCIO-CO  
Cdr, Kansas AAP, ATTN: SMCKA-CO  
Cdr, Lake City AAP, ATTN: SMCLC-CO  
Cdr, Lone Star AAP, ATTN: SMCLS-CO  
Cdr, Longhorn AAP, ATTN: SMCLO-CO  
Cdr, Louisiana AAP, ATTN: SMCLA-CO



AMXIB-MT

DISTRIBUTION (Cont'd):

Army Ammunition Plants (Cont'd):

Cdr, McAlester AAP, ATTN: SMCMC-PM/Mr. Garold Stevens  
Cdr, Milan AAP, ATTN: SMCMI-CO  
Cdr, Mississippi AAP, ATTN: SMCMS  
Cdr, Radford AAP, ATTN: SMCRA-CO  
Cdr, Riverbank AAP, ATTN: SMCRB-CO  
Cdr, Scranton AAP, ATTN: SMCSC-CO

Depots:

Cdr, Anniston Army Depot, ATTN: SDSAN-MD, SDSAN-DRM-MOD/R. W. Blicker,  
SDSAN-DRM-PPM/Mike Trowse  
Cdr, Corpus Christi Army Depot, ATTN: SDSCC-MPI, SDSCC-CME/Brenda Lake,  
SDSCC-MPI/Don Wells  
Cdr, Letterkenny Army Depot, ATTN: SDSLE-MM, SDSLE-MME/David Kaufman,  
SDSLE-MM/Michael Baccellieri  
Cdr, Mainz Army Depot, ATTN: SDSMZ-FMD/Ruby Demesone  
Cdr, New Cumberland Army Depot, ATTN: SDSNC-ME, SDSNC-F/Joseph Bush,  
SDSNC-QQ-R/Technical Library  
Cdr, Red River Army Depot, ATTN: SDSRR-MO, SDSRR-ME/Gary Fuller  
Cdr, Sacramento Army Depot, ATTN: SDSSA-MPE, SDSSA-QSM-2/Mike Sheehan,  
SDSSA-RPM-1/Pat Coghlan  
Cdr, Seneca Army Depot, ATTN: SDSSE-OP, SDSSE-FX/Scott Woodworth  
Cdr, Sharpe Army Depot, ATTN: SDSSH-R, SDSSH-FMD/John Creedon  
Cdr, Sierra Army Depot, ATTN: SDSSI-EM, SDSSI-DED/Donald Smedes  
Cdr, Tobyhanna Army Depot, ATTN: SDSTO-M, SDSTO-ME-E/Frank Estock, Technical  
Library  
Cdr, Tooele Army Depot, ATTN: SDSTE-MAE, SDSTE-FM/Stan Perkes

Army Organizations:

Dir, AMC Intern Training Center, ATTN: AMXMC-ITC-E/Mr. Carter, Mr. Achord,  
AMXMC-ITC-L/Mr. H. E. Lynch  
Cdr, Army Air Mobility R&D Labs, ATTN: Technical Library  
Cdr, Army Applied Tech Labs, ATTN: DAVDL-ATL-ATS/Mr. J. Waller (3 cys)  
Cdr, Army Foreign Science and Technology Center, ATTN: AMXST-MT1/  
Mr. James Wamsley (2 cys)  
Cdr, Army Logistics Management Center, ATTN: AMXMD  
Dir, Army Management Engineering Training Activity, ATTN: AMXOM-SE/  
Dr. Shallman (3 cys)  
Cdr, Army Plant Rep Office, ATTN: SAVBV-Q/Mr. James Doyle  
Cdr, Army Research Office, ATTN: AMXRO-AO  
Cdr, Army Signals Warfare Lab, ATTN: DELSW-MP  
Cdr, Detroit Arsenal Tank Plant, ATTN: AMCPM-M60-TP/Mr. Tom Zemke (2 cys)  
Cdr, Dugway Proving Grounds, ATTN: Technical Library  
Cdr, Harry Diamond Labs, ATTN: DELHD-CO (6 cys), DELHD-PO-P/  
Mr. Julius Hoke (3 cys)  
Cdr, Night Vision & Electro-Optics Lab, ATTN: DELNV-SE  
Cdr, White Sands Missile Range, ATTN: STEWS-TE-TL/Technical Library  
Cdr, Yuma Proving Grounds, ATTN: Technical Library

NASA

Ames Research Center, ATTN: Dr. Walter Goldenrath

AMXIB-MT

DISTRIBUTION (Cont'd):

Air Force:

Cdr, Air Force, ATTN: USAF/RDCM/MAJ E. Ross, The Pentagon  
Cdr, Air Force Systems Command, ATTN: AFSC/DLF, AFSC/PPD, SD/PDP/Mr. Henry Black, ASD/ENSID/Mr. John Hiles  
Cdr, Air Force Wright Aeronautical Lab, ATTN: AFWAL/LT, AFWAL/LTE, AFWAL/LTM, AFWAL/LTN, AFWAL/MLSS (1 cy ea)  
Cdr, Hanscom AFB, ATTN: AFGL-SULL/R. Bergmann, Mr. John Orphanos  
Dir, Marshall Space Flight Center, ATTN: AT-01/Mr. Walt Crumpton  
Cdr, San Antonio Air Logistics Ctr, ATTN: B. Boisvert-MMEI, Kelly AFB

Navy Organizations:

Cdr, Long Beach Naval Shipyard, ATTN: Code 202.4/Mrs. Zeoli, Code 385/  
Mr. Louis H. Smith  
Cdr, Los Alamos National Laboratory, ATTN: A. P. Torres  
Cdr, Naval Air Systems Command, ATTN: Code AIR 7640/Mr. R. A. Retta  
Cdr, Naval Material Command, ATTN: Code 064/Mr. J. W. McInnis  
Dir, Naval Mat Comd Ind Resources Detachment, Officer-In-Charge, Bldg. 75-2  
Cdr, Naval Ocean Systems Ctr, ATTN: Code 926/Dr. Wil Watson  
Cdr, Naval Ordnance Station, ATTN: Code 5253/Mr. Craig Smith  
Cdr, Naval Sea Systems Command, ATTN: Code SEA-05R23/Mr. T. E. Draschil  
Cdr, Naval Ship Systems Engrg Station, ATTN: 035.1  
Cdr, Naval Surface Wpns Ctr/Dahlgren, ATTN: Code G-52/Mr. E. E. Rowe, Jr.  
Cdr, Naval Surface Wpns Ctr/Dahlgren Lab, ATTN: Code E 431  
Cdr, Naval Surface Wpns Ctr/White Oak Lab, ATTN: Code E345/Mr. Chas. McFann  
Cdr, Naval Weapons Ctr, ATTN: Code 36404

Miscellaneous Organizations:

Aerospace Industries Association (2 cys)  
ATTN: Mr. Walter Weitner, 1725 Desales St., N.W., Washington, DC 20036  
American Defense Preparedness Association (2 cys)  
ATTN: Mr. William Holt, 1700 N. Moore Street, Arlington, VA 22209  
American Society for Metals (1 cy)  
ATTN: Mr. James Hontas, Metals Park, OH 44073  
American Society for Testing and Materials (2 cys)  
ATTN: Mr. Samuel F. Etris, Special Assistant, 1916 Race Street,  
Philadelphia, PA 19103  
Assoc. for Intergrated Mfg Tech (2 cys)  
ATTN: Ms. Marti DeGraaf, 111 East Wacker Dr., Suite 600, Chicago, IL 60601  
Cast Metal Federation (2 cys)  
ATTN: Mr. William E. Gephardt, Chairman, Govt. Supply Committee,  
4870 Packard Road, Niagara Falls, NY 14304  
Center for Utilization of Federal Technology (1 cy)  
ATTN: Mr. Edward J. Lehmann, Room 11R, NTIS, Springfield, VA 22161  
Electronic Industrial Association (20 cys)  
ATTN: Mr. Jean Caffiaux, 2001 I St., N.W., Washington, DC 20006  
Forging Industry Association (10 cys)  
ATTN: Mr. C. G. Scofield, Room 1121, 55 Public Square,  
Cleveland, OH 44113  
Metcut Research Associates, Inc. (1 cys)  
ATTN: Dr. John Kahles, 3980 Rosslyn Drive, Cincinnati, OH 45209-1196  
Society of Manufacturing Engineers (1 cy)  
ATTN: Messrs. Thomas Heath, Thomas Akas, One SME Drive, P.O. Box 930,  
Dearborn, MI 48128