

MICROCOPY RESOLUTION TEST CHART
NATIONAL BUREAU OF STANDARDS-1963-A

UNCLASSIFIED

SECURITY CLASSIFICATION OF THIS PAGE (When Data Entered)

AD-A158 349

REPORT DOCUMENTATION PAGE		READ INSTRUCTIONS BEFORE COMPLETING FORM	
1. REPORT NUMBER RO 21671.1-EG	2. GOVT ACCESSION NO. 22148.1-EG-RI N/A	3. RECIPIENT'S CATALOG NUMBER N/A	
4. TITLE (and Subtitle) Stress Analysis Combining Speckle Metrology with Finite Element Modelling		5. TYPE OF REPORT & PERIOD COVERED Reprint	
6. AUTHOR(s) Matthys, D.R., Dudderar, T.D., Gilbert, J.A., Taher, M.A., Johnson, H.S.		7. PERFORMING ORG. REPORT NUMBER	
8. CONTRACT OR GRANT NUMBER(s) DAAG 29-84-K-0183 DAAG 29-84-G-0045		9. PROGRAM ELEMENT, PROJECT, TASK AREA & WORK UNIT NUMBERS N/A	
10. PERFORMING ORGANIZATION NAME AND ADDRESS Board of Regents - Univ. of Wisconsin System University of Wisconsin-Milwaukee Milwaukee, Wisconsin 53201		11. CONTROLLING OFFICE NAME AND ADDRESS U. S. Army Research Office Post Office Box 12211 Research Triangle Park NC 27709	
12. MONITORING AGENCY NAME & ADDRESS (if different from Controlling Office)		13. REPORT DATE invited paper, SPIE conference	
		14. NUMBER OF PAGES 12	
		15. SECURITY CLASS. (of this report) Unclassified	
		15a. DECLASSIFICATION/DOWNGRADING SCHEDULE	
16. DISTRIBUTION STATEMENT (of this Report) Approved for public release; distribution unlimited.			
17. DISTRIBUTION STATEMENT (of the abstract entered in Block 20, if different from Report) NA			
18. SUPPLEMENTARY NOTES The view, opinions, and/or findings contained in this report are those of the author(s) and should not be construed as an official Department of the Army position, policy, or decision, unless so designated by other documentation.			
19. KEY WORDS (Continue on reverse side if necessary and identify by block number) Speckle Metrology, Hybrid Stress Analysis, Digital Image Processing			
20. ABSTRACT (Continue on reverse side if necessary and identify by block number) The work described in this paper represents an effort to demonstrate the validity of the hybrid approach to the analysis of structural deformation. Mathematical modelling was incorporated into the process of reducing data from a digital correlation analysis of speckle data. Considerable savings of time and resources can be realized through this approach and the strengths of the theoretical and experimental procedures complement each other beautifully. The final results agreed within a few percent of each other and with values obtained by another independent method (high frequency moire),			

DTIC ELECTED

AUG 27 1985

DTIC FILE COPY

UNCLASSIFIED

SECURITY CLASSIFICATION OF THIS PAGE (When Data Entered)

demonstrating the accuracy of the procedure.

UNCLASSIFIED

Stress analysis combining speckle metrology with finite element modelling

D. R. Matthys
Marquette University
Milwaukee, WI 53233

T. D. Dudderar
AT&T Bell Labs
Murray Hill, NJ 07974

J. A. Gilbert
University of Wisconsin-Milwaukee
Milwaukee, WI 53201

M. A. Taher
University of Wisconsin-Milwaukee
Milwaukee, WI 53201

H. S. Johnson
University of Wisconsin-Milwaukee
Milwaukee, WI 53201

Abstract

The work described in this paper represents an effort to demonstrate the validity of the hybrid approach to the analysis of structural deformation. Mathematical modelling was incorporated into the process of reducing data from a digital correlation analysis of a speckled surface. The experimental data was collected both by directly imaging the surface onto a digitizing vidicon system and by transmitting the image through a coherent optical fiber bundle. Considerable savings of time and resources can be realized through the hybrid approach and the strengths of the theoretical and experimental procedures complement each other beautifully. The final results agreed within a few percent of each other and with values obtained by another independent method (high frequency moire), demonstrating the accuracy of the procedure. *Key words: Digital image processing.*

Hybrid approach

The idea of a hybrid approach to structural analysis is not new[1,2,3,4]. Although a long history of development can be traced for engineering studies based on mathematical models (finite-difference equations, boundary value integrals, finite element models) and on experimentally obtained data (gaging, optical or acoustical metrology), each method has well known limitations. Mathematical studies depend on the correspondence between some abstract model undergoing specified affects and a real structure subjected to a complex of interacting forces. A detailed model quickly becomes very large and mathematically complex, placing large burdens on the computational and financial resources of the designer. Also, the validity of the results depends on how well boundary conditions have been incorporated into the model.

On the other hand, direct experimental methods of analysis often depend on only a few data values, measured at isolated points on the structure. The obtaining of this data for certain critical regions may be difficult or dangerous (complex structures, inaccessible locations, hazardous environments). In such cases, the surface can be illuminated by an incoherent fiber optic bundle and the image transmitted back through a coherent fiber optic bundle to a remote analyzing system.

The hybrid method is an attempt to take advantage of the strengths of these two approaches, while minimizing their weaknesses. Basically, the idea is to drastically reduce the finite element mesh required and to incorporate real measured values instead of generalized boundary conditions.

Speckle metrology

Surface motion studies using speckle photography (as opposed to speckle interferometry[5]) usually fall into one of two basic classes: methods that use fringes[6] and methods that utilize digital correlation techniques[7,8]. The former approach has the advantage of simplicity, but only a few fringes can be obtained and they are overlaid with secondary speckle resulting from the coherent light used to interrogate the specklegram, making precise measurements difficult. Also, photographic techniques must be employed to produce the specklegram, and to be observable the minimum deformation must be at least equal to the size of the speckles being used. On the other hand, digital techniques require a digitization system and computer codes for correlation; also, the data obtained are less easily understood. However, these digital methods obviate the need for photographic work and are not limited to displacements greater than the speckle size. Utilization of a fiber optic bundle, however, requires that the speckle size be at least equal to three times the diameter of a single fiber in the bundle[9].

Experiment

In order to compare the hybrid approach with the standard finite element method, an experiment was carried out using both techniques. A simple structure was modelled with a finite element mesh on which mathematical analysis could be performed using a standard commercial finite element program (ANSYS), and the same structure was realized in a physical model. The structure used in the experiment was a notched beam approximately 76 mm x 12 mm x 9 mm made of PSM-1 polycarbonate material with a small notch of approximately 3 mm radius cut into the bottom edge at the center of the long dimension. (Cf. Figure 1.)

The finite element mesh used to model the notched beam is shown in Figure 2a. Because of the symmetry of the design, only half of the beam had to be actually analyzed. Boundary conditions appropriate to the known loading configuration were selected and these boundary conditions, together with the mesh, were input to the finite element program (ANSYS) running on a mainframe computer. The ANSYS program produced a listing of the displacements at all the nodal points and a plot of the stress intensity values throughout the entire half-model. This plot is shown in Figure 3, where the stress intensity contours are labelled in multiples of 3.45 MPa (500 psi). Assuming that trust is placed in the mesh used to model the notched beam and that the boundary conditions specified accurately describe the loading, the problem of the notched beam has been solved. Displacements and stresses are known throughout the beam.

To perform the second half of the investigation, the prototype was mounted in a loading frame so that a contact line across the top of the beam (above the notch) held the center of the top edge fixed, while upward motions of 254 microns were imposed by two load lines spaced 50.8 mm apart and centered across the bottom of the device (cf. Figure 1). In order to produce artificial "white light" speckle, the notched beam was first spray painted white, then black paint was spattered randomly over its surface.

This surface was then illuminated with the light from a tungsten filament lamp transmitted through a small fiber bundle. The reflected light was imaged directly onto a vidicon camera (Hamamatsu C1000) and the collected image digitized into a 256 by 256 pixel array, with intensity levels distributed over an 8-bit gray scale. The optical setup for data acquisition is shown in Figure 4.

A subset of the finite element model was chosen to enclose the notched area of the beam. A set of nine locations was selected around the boundary of the subregion, corresponding to the nodal points of the boundary of the finite element mesh for the same region. This region, with the specified locations, is shown in Figure 2b.

The full-field speckle patterns obtained from this region before and after deformation of the beam were digitized, and then submitted to a correlation routine. The program used in this study performed a two dimensional correlation and assumed that the displacements were homogeneous over small areas. No corrections were made for possible rotation or warping. If these types of displacement are anticipated, more complex routines, as presented in Reference 8, may be used. However, the program did incorporate Lagrangian weighting functions to allow interpolation of subpixel displacements. The 'u' and 'v' displacements calculated by the program for the selected locations are given in Table 1.

These values were now input as nodal displacements to the small mesh consisting of only that portion of the original mesh which modelled the subregion. This small mesh, together with the boundary values (measured nodal displacements), was submitted to the ANSYS program. An enlarged view of that section of Figure 3 which contains the subregion of interest is shown in Figure 5a. This plot shows the stress intensity contours as determined by a standard finite element approach, while the ANSYS output plot of stress intensity values determined using the experimentally measured nodal displacements for the same region is shown in Figure 5b. Although there are some discrepancies between the two figures around the outer boundaries (this effect was also discussed in Reference 2) due to experimental inaccuracies, the close agreement between the two plots for the region around the notch is visually obvious. The maximum stress intensity at the root of the notch was calculated by ANSYS as 25.0 MPa (3617 psi) using the standard finite element approach and as 25.4 MPa (3679 psi) using the hybrid approach, a difference of only 2 percent.

A coherent fiber optic bundle was now used to transmit the surface image to the vidicon camera (cf. Figure 6). The whole analysis was repeated and the displacement values obtained for the selected nodal points are given in Table 2. Minor variations between the displacements given in Table 1 and those in Table 2 are to be expected, since the model was unloaded and then loaded again for the fiber optic bundle test.

These values were input to ANSYS and the stress plot obtained is shown in Figure 5c. The same comments could be made here as for the direct image analysis; around the boundary, minor irregularities are evident, but in the neighborhood of the notch, agreement with the two previous plots is excellent. The ANSYS program gave a maximum stress intensity value at the notch root of 24.7 MPa (3573 psi), which again is within 2 per cent of the value obtained for a full finite element analysis.

Summary

The excellent agreement between the results obtained from the standard finite element method and from a hybrid approach demonstrates the validity of the latter, while the much simpler mesh and the incorporation of actual data values demonstrate its power and increase confidence in the results.

Although a full finite element analysis has advantages for the initial design of a structure and allows the specification of overall system parameters, it is cumbersome and expensive when the task is to analyze local anomalies in an existing structure. In this latter case, the hybrid approach can be a much simpler and more cost effective way to solve problems or to study the response of prototypes.

The experimental data required for the application of the hybrid method can be obtained in many ways. In this project, nodal displacements were obtained by using artificial speckle. These data were acquired both by direct imaging and by transmission through a fiber optic bundle. Another measurement technique that has been used is high frequency moire[10]. Equivalent results were obtained from all these methods, demonstrating that the power of the hybrid approach is not in the particular measurement technique utilized, but in the incorporation of experimentally measured values obtained from the actual structure (or a model of the structure) into a finite element routine.

Acknowledgments

The authors gratefully acknowledge the support of the Army Research Office (Grant Nos. DAAG 29-84-K-0183 and DAAG 29-84-G-0045) and the National Science Foundation (Grant No. MEA-8305597).

Table 1

Displacement values for selected locations (nodes) on notched beam. Data obtained by direct imaging of surface onto vidicon. Values calculated using speckle correlation and inserted into ANSYS finite-element program.

Node	u (mm)	v (mm)
1	0.055	0.058
2	0.042	0.057
3	0.023	0.054
4	0.008	0.057
5	0.001	0.055
6	0.000	0.037
7	0.000	0.021
8	0.000	0.011
9	-0.001	0.008

Table 2

Displacement values for selected locations (nodes) on notched beam. Data obtained by transmitting image through fiber bundle. Values calculated using speckle correlation and inserted into ANSYS finite-element program.

Node	u (mm)	v (mm)
1	0.050	0.053
2	0.037	0.057
3	0.028	0.051
4	0.014	0.058
5	-0.001	0.057
6	0.000	0.040
7	0.002	0.027
8	0.002	0.018
9	-0.001	0.014



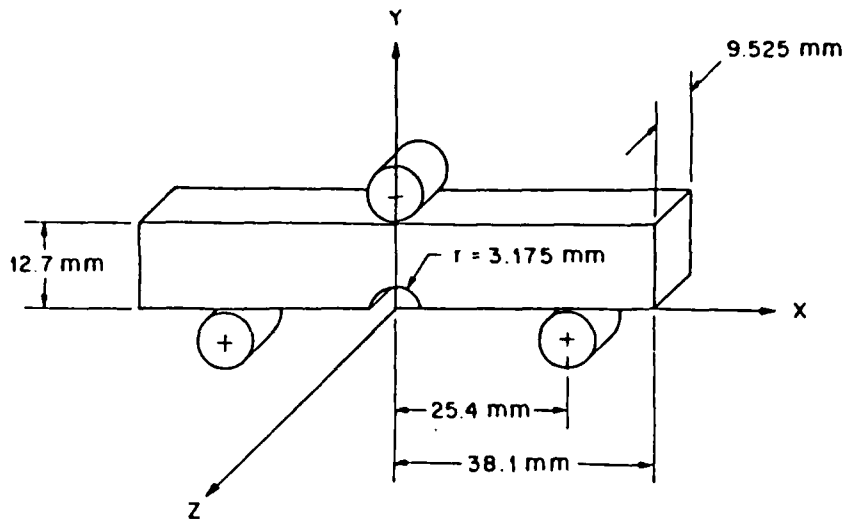

Figure 1. Notched beam used for comparing standard finite element method with hybrid approach to analysis.

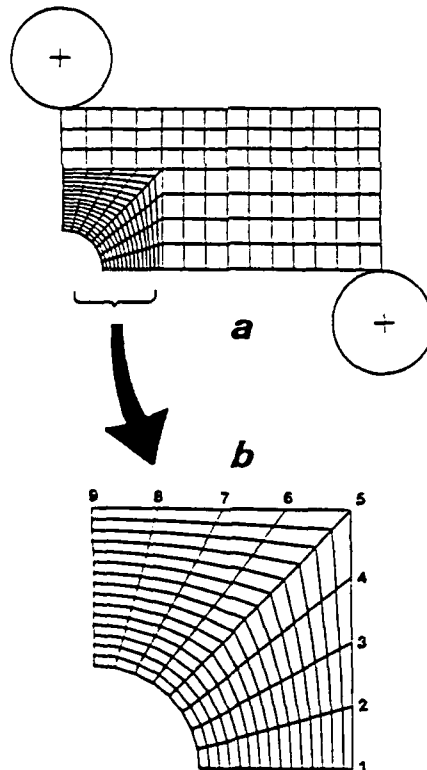

Figure 2. a) Finite element mesh used to model the notched beam of Figure 1. Because of symmetry, only half of the beam has to be modelled.

b) Subregion of mesh around the notch in the beam. Numbers indicate locations (nodes) chosen for displacement analysis using speckle correlation technique.



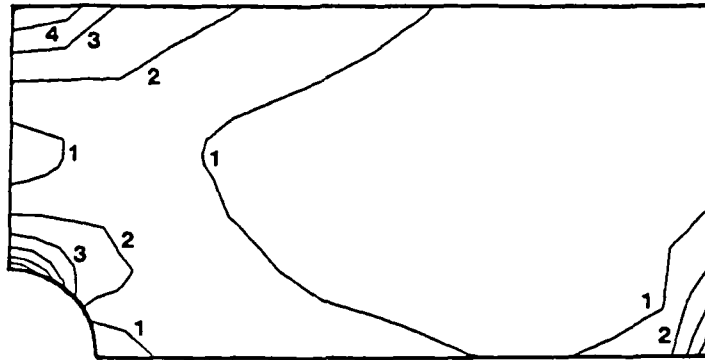

Figure 3. Stress intensity plot for the notched beam under load. Values are calculated by standard finite-element method. Stress intensity contours are labelled in multiples of 3.45 MPa (500 psi).

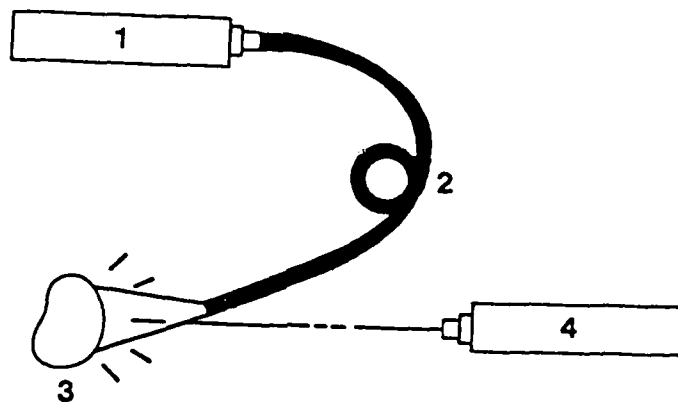

Figure 4. Experimental setup for direct imaging of speckled surface onto vidicon digitizing camera. (1) tungsten lamp, (2) incoherent fiber optic bundle, (3) test surface with artificial speckle, (4) vidicon camera.

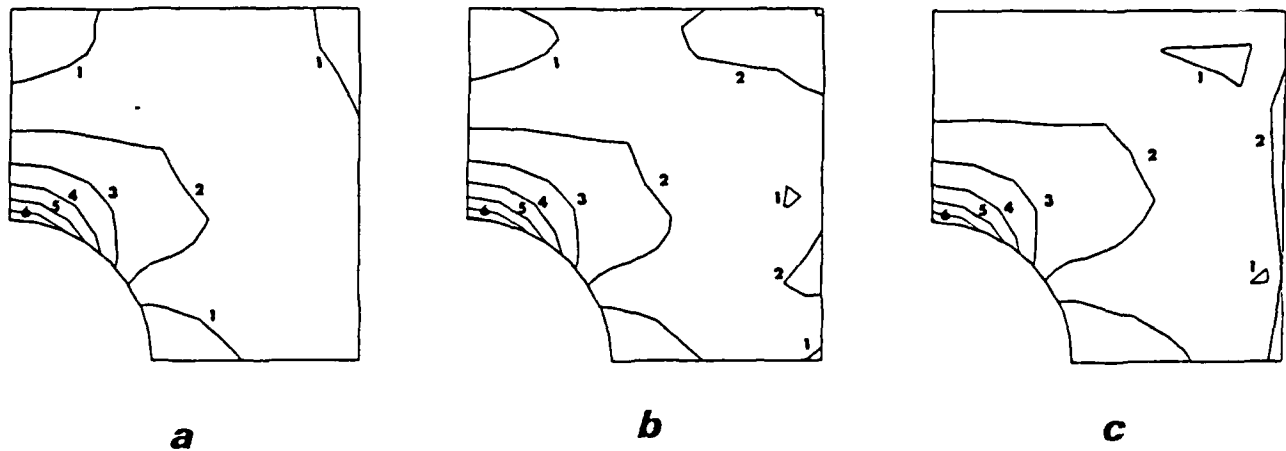

Figure 5. a) Stress intensity plot for subregion around notch. This is an enlargement of part of Figure 3. Contours are labelled in multiples of 3.45 MPa (500 psi).
 b) Stress intensity plot for subregion around notch as calculated by ANSYS using nine measured values of nodal displacement. Contours labelled as in a).
 c) Stress intensity plot using data obtained through coherent fiber optic bundle.

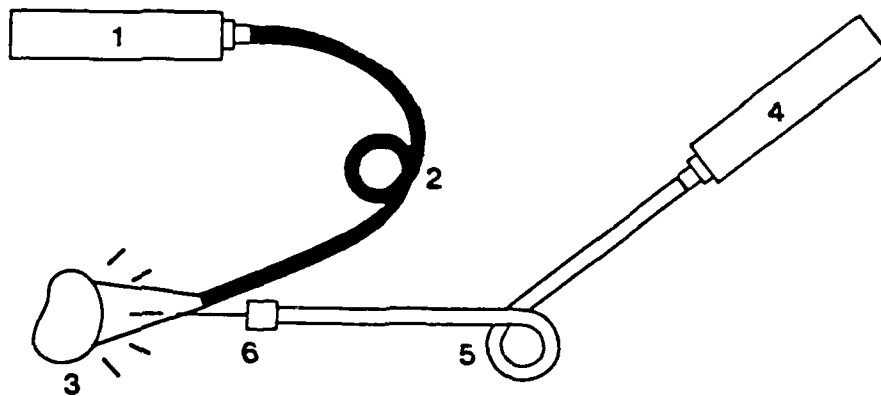
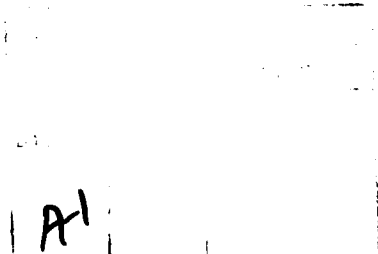

Figure 6. Experimental setup with image transmitted to digitizing camera through coherent fiber optic bundle. (1) tungsten lamp, (2) incoherent fiber optic bundle, (3) test surface with artificial speckle, (4) vidicon camera, (5) coherent fiber optic bundle, (6) imaging lens.

References

1. Barishpolsky, B. M., "A Combined Experimental and Numerical Method for the Solution of Generalized Elasticity Problems," *Experimental Mechanics* 20, No. 10, 345-349 (1980).
2. Weathers, J. M., Foster, W. A., Swinson, W. F., Turner, J. L., "Integration of Laser Speckle and Finite Element Techniques of Stress Analysis," *Experimental Mechanics* 25, No. 1, 60-65 (1985).
3. Kobayashi, A. S., "Hybrid Experimental-Numerical Stress Analysis," *Experimental Mechanics* 23, No. 3, 388-347 (1983).
4. Gilbert, J. A., Dudderar, T. D., Schamell, J. H., Van Rossum, E. J., "Initial Studies on the Development of a Hybrid Method for Stress Analysis," AT&T Bell Laboratories Technical Memorandum (1984).
5. Stetson, K. A., "Review of Speckle Photography and Interferometry," *Optical Engineering* 14, No. 5, 482-489 (1975).
6. Erf, R. K., (ed.), "Speckle Metrology," Academic Press, New York, 1978. Cf. chapters 4 and 5.
7. Dudderar, T. D., Gilbert, J. A., "Fiber Optic Measurement of the Deformation Field on a Remote Surface Using Numerically Processed White-Light Speckle," *Applied Optics* 21, 3520-3527 (1982).
8. Peters, W. H., Ranson, W. F., et al, "Application of Digital Correlation Methods to Rigid Body Mechanics," *Optical Engineering* 22, No. 6, 738-742 (1983).
9. Dudderar, T. D., Gilbert, J. A., Beohnlein, A. J., Schultz, M. E., "Application of Fiber Optics to Speckle Metrology--a Feasibility Study," *Experimental Mechanics* 23, No. 3, 289-297 (1983).
10. Gilbert, J. A., Dudderar, T. D., Matthys, D. R., Johnson, H. S., Franzel, R. A., "Hybrid Stress Analysis Combining High Frequency Moire Patterns with Finite Element Modeling," AT&T Bell Laboratories Technical Memorandum (1985).



RTIS

@A158349 U FIELD/GROUP eeeee

UNCLASSIFIED TITLE
STRESS ANALYSIS COMBINING SPECKLE METROLOGY WITH FINITE ELEMENT MODELING.

FINITE ELEMENT MODELING
USE FINITE ELEMENT ANALYSIS
MODELS

STRESS ANALYSIS
USE STRESS ANALYSIS

POSTING TERMS ASSIGNED

SPECKLE METROLOGY
USE METROLOGY
SPECULAR REFLECTION

PHRASES NOT FOUND DURING LEXICAL DICTIONARY MATCH PROCESS

UNCLASSIFIED

PAGE 6

SEP 19, 1985

UNCLASSIFIED

PREVIOUS PAGE
IS BLANK

END

FILMED

10-85

DTIC