

AD-A156 986    DESIGN AND SPECIFICATION OF LOW PRESSURE SEWER SYSTEMS    1/1  
FOR RECREATION AREAS(U) ARMY ENGINEER WATERWAYS  
EXPERIMENT STATION VICKSBURG MS ENVIR.    M J CULLINANE  
UNCLASSIFIED    FEB 85 WES/TR/EL-85-1    F/G 13/2    NL

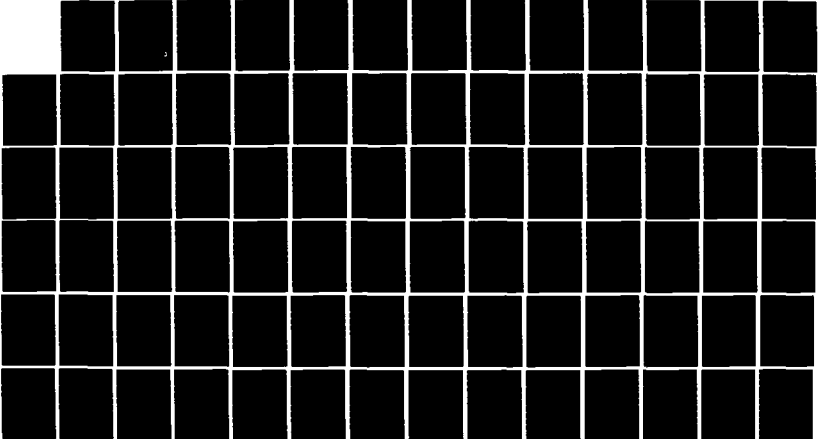

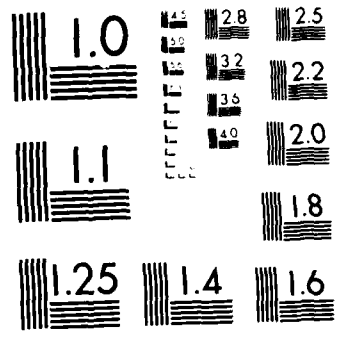

MICROCOPY RESOLUTION TEST CHART  
NATIONAL BUREAU OF STANDARDS-1963-A

2

TECHNICAL REPORT

# DESIGN AND SPECIFICATION OF LOW PRESSURE SEWER SYSTEMS FOR RECREATION AREAS

AD-A156 986

Author(s)  
Title

FOR THE ARMY  
Waterways Experiment Station, Corps of Engineers  
Vicksburg, Mississippi 39180-0631



DTIC FILE COPY

DTIC  
ELECTE  
JUL 15 1985  
S D  
G

FOR THE ARMY  
Waterways Experiment Station, Corps of Engineers  
Vicksburg, Mississippi 39180-0631

85 6 25 014

Destroy this report when no longer needed. Do not return it to the originator.

The findings in this report are not to be construed as an official Department of the Army position unless so designated by other authorized documents.

<b>Accession For</b>	
NTIS GEA&I	<input checked="" type="checkbox"/>
DTIC TAB	<input type="checkbox"/>
Unannounced	<input type="checkbox"/>
Justification	
By _____	
Distribution/	
Availability Codes	
Dist	Avail and/or Special
A1	

The contents of this report are not to be used for advertising, publication, or promotional purposes. Citation of trade names does not constitute an official endorsement or approval of the use of such commercial products.

Unclassified

SECURITY CLASSIFICATION OF THIS PAGE (When Data Entered)

REPORT DOCUMENTATION PAGE		READ INSTRUCTIONS BEFORE COMPLETING FORM	
1. REPORT NUMBER Technical Report EL-85-1	GOVT ACCESSION NO. <b>AD-A156996</b>	ADVISORY	ATTACHMENT NUMBER
4. TITLE (and Subtitle) DESIGN AND SPECIFICATION OF LOW PRESSURE SEWER SYSTEMS FOR RECREATION AREAS	TYPE OF REPORT & PERIOD COVERED Final report		
7. AUTHOR(s) M. John Cullinane, Jr.	5. PERFORMING ORG. REPORT NUMBER		
9. PERFORMING ORGANIZATION NAME AND ADDRESS US Army Engineer Waterways Experiment Station Environmental Laboratory PO Box 631, Vicksburg, Mississippi 39180-0631	8. CONTRACT OR GRANT NUMBER		
11. CONTROLLING OFFICE NAME AND ADDRESS DEPARTMENT OF THE ARMY US Army Corps of Engineers Washington, DC 20314-1000	10. PROGRAM ELEMENT PROJECT, TASK AREA & WORK UNIT NUMBER Work Unit 31687		
14. MONITORING AGENCY NAME & ADDRESS (if different from Controlling Office)	12. REPORT DATE February 1985		
	13. NUMBER OF PAGES 78		
	15. SECURITY CLASS. of this report Unclassified		
	15a. SECURITY CLASS. of this report SCHEDULE		
16. DISTRIBUTION STATEMENT (of this Report)  Approved for public release; distribution unlimited.			
17. DISTRIBUTION STATEMENT (of the abstract entered on Block 20, if different from Report)			
18. SUPPLEMENTARY NOTES  Available from National Technical Information Service, 5285 Port Royal Road, Springfield, Virginia 22161.			
19. KEY WORDS (Continue on reverse side if necessary; and identify by block number) Recreation areas--hydraulic aspects (IC) Sewage disposal plants--design and construction (IC) Sanitary engineering (IC) Specifications (IC)			
20. ABSTRACT (Continue on reverse side if necessary; and identify by block number) The objective of a wastewater collection system is to convey wastes from the point of generation to the point of treatment or disposal. Pressure sewer systems have been suggested as a cost-effective alternative to gravity sewer systems in those cases where topographic or geological constraints make gravity sewer systems prohibitively expensive or technically unfeasible. The geographic criteria for gravity sewer systems are well developed and readily available. (Continued)			

Unclassified

SECURITY CLASSIFICATION OF THIS PAGE (When Data Entered)

ABSTRACT (Continued)

the other hand, design criteria for pressure sewer systems are limited and difficult to obtain. This report codifies design criteria for pressure sewer systems.

The design of pressure sewer systems is accomplished by evaluating the requirements of the two major components of the system: the onsite pressurization unit and the offsite pressure sewer main. Design criteria and standards are presented for both the onsite and offsite portions of the system. Onsite facility design criteria include standards for septic tanks and wetwells, pressurization units, onsite piping, and onsite appurtenances. Offsite facility design criteria include standards for hydraulic design, materials of construction, appurtenances, installation and testing, and special construction requirements.

In addition to the specific design criteria, information is also provided on general system design considerations, estimation of design flows, and system costs. The emphasis in each of these areas is placed on the unique requirements associated with US Army Corps of Engineers recreation areas.

Accession For	
NTIS GRA&I	<input checked="" type="checkbox"/>
DTIC TAB	<input type="checkbox"/>
Unannounced	<input type="checkbox"/>
Justification	<input type="checkbox"/>
By _____	
Distribution/ _____	
Availability Codes	
Dist. _____	Special and/or _____
Special _____	_____

Unclassified

SECURITY CLASSIFICATION OF THIS PAGE (When Data Entered)

## PREFACE

The study reported herein was funded by the Office, Chief of Engineers, US Army, from Civil Works Appropriation 96X3123, "General Investigations - Research and Development," Work Unit 31687, "Innovative/Alternative Wastewater Collection, Transportation, and Treatment Systems for Recreation Areas."

The study was conducted during 1983 by personnel of the Environmental Engineering Division (EED) of the Environmental Laboratory (EL), US Army Engineer Waterways Experiment Station (WES).

The study was conducted by Mr. M. John Cullinane, Jr., under the direct supervision of Mr. Norman R. Francingues, Chief, Water Supply and Waste Treatment Group, and the general supervision of Mr. Andrew J. Green, Chief, EED, and Dr. John Harrison, Chief, EL.

The information presented in this report is adapted from design and specification guidelines for low pressure sewer systems developed by a technical advisory committee to the State of Florida Department of Environmental Regulation. Appreciation is extended to the Department for allowing use of these guidelines as the foundation for developing low pressure sewer design criteria for recreation areas. Appreciation is also extended to Mr. W. Carroll Murphy of Engineering Service, Inc., Jackson, Miss., for furnishing the cover photographs.

Commander and Director of WES during the study and preparation of this report was COL Tilford C. Creel, CE. Technical Director was Mr. F. R. Brown.

This report should be cited as follows:

Cullinane, M. J., Jr. 1985. "Design and Specification of Low Pressure Sewer Systems for Recreation Areas," Technical Report EL-85-1, US Army Engineer Waterways Experiment Station, Vicksburg, Mississippi.

## CONTENTS

	<u>Page</u>
PREFACE . . . . .	1
LIST OF FIGURES . . . . .	3
CONVERSION FACTORS, US CUSTOMARY TO METRIC (SI)	
UNITS OF MEASUREMENT . . . . .	4
PART I: INTRODUCTION . . . . .	5
Background . . . . .	5
Purpose and Scope . . . . .	6
Organization of Report . . . . .	6
PART II: GENERAL DESIGN CONSIDERATIONS . . . . .	7
Background . . . . .	7
System Components . . . . .	8
Design Factors . . . . .	12
Wastewater Quality and Treatment . . . . .	16
Contingency Planning . . . . .	17
Summary . . . . .	18
PART III: DESIGN FLOWS . . . . .	19
Background . . . . .	19
Fixture Unit Method . . . . .	19
Per Capita Use Method . . . . .	22
PART IV: ONSITE FACILITY CONSTRUCTION . . . . .	27
Background . . . . .	27
Septic Tank and Wetwell . . . . .	27
Pressurization Units . . . . .	31
Onsite Piping . . . . .	32
Appurtenances . . . . .	35
PART V: PRESSURE SEWER MAIN CONSTRUCTION . . . . .	38
Hydraulic Design . . . . .	38
Materials of Construction . . . . .	42
Appurtenances . . . . .	45
Installation and Testing . . . . .	54
Special Construction . . . . .	56
PART VI: SYSTEM COSTS . . . . .	59
Capital . . . . .	59
Operation and Maintenance . . . . .	61
PART VII: SUMMARY . . . . .	64
REFERENCES . . . . .	66
TABLES 1-12	



LIST OF FIGURES

<u>Figure</u>		<u>Page</u>
1	Typical components of pressure sewer systems . . . . .	10
2	Typical grinder pump pressurization unit installation . . . . .	11
3	Typical septic tank-effluent pumping pressurization unit installation . . . . .	12
4	Pump capacity based on total value of fixture units . . . . .	20
5	Fixture units for a male comfort station . . . . .	20
6	Fixture units for a female comfort station . . . . .	21
7	Fixture units for a male bathhouse . . . . .	21
8	Fixture units for a female bathhouse . . . . .	22
9	Mean daily water use at JFK and Heber Springs recreation areas . . . . .	23
10	Mean hourly water use for Loop F campground at Heber Springs recreation area . . . . .	25
11	Mean hourly water use for Camp Area Z and campsites Y7-Y14 at JFK recreation area . . . . .	25
12	Mean hourly water use for all campsites at Heber recreation area . . . . .	26
13	Mean hourly water use for all campsites at JFK recreation area . . . . .	26
14	Volume of septic tank for various design flows . . . . .	28
15	Typical capacity-head characteristics for centrifugal and semipositive displacement grinder pumps . . . . .	31
16	Nodal schematic representation of a pressure sewer system . . . . .	41
17	Schematic representation of pump head calculation . . . . .	43
18	Valve box and cleanout arrangement along straight run and in changes of direction . . . . .	46
19	Valve box and cleanout arrangement with hose connection . . . . .	47
20	Valve box and cleanout arrangement at intersection of pressure sewer mains . . . . .	48
21	Cleanout arrangement at end of pressure sewer main . . . . .	49
22	Terminal manhole connection . . . . .	52
23	Typical service connections to pressure sewer mains . . . . .	53

CONVERSION FACTORS, US CUSTOMARY TO METRIC (SI)  
UNITS OF MEASUREMENT

US customary units of measurement used in this report can be converted to metric (SI) units as follows:

Multiply	By	To Obtain
Fahrenheit degrees	5/9	Celsius degrees or Kelvins*
feet	0.3048	metres
feet per second	0.3048	metres per second
gallons per day	3.785412	cubic decimetres per day
gallons per hour	3.785412	cubic decimetres per hour
gallons per minute	3.785412	cubic decimetres per minute
gallons (US liquid)	3.785412	cubic decimetres
horsepower (electric)	746.0	watts
inches	25.4	millimetres
miles (US statute)	1.609347	kilometres
pounds (force) per square inch	6894.757	pascals

\* To obtain Celsius (C) temperature readings from Fahrenheit (F) readings, use the following formula:  $C = (5/9)(F - 32)$ . To obtain Kelvin (K) readings, use  $K = (5/9)(F - 32) + 273.15$ .

DESIGN AND SPECIFICATION OF LOW PRESSURE  
SEWER SYSTEMS FOR RECREATION AREAS

PART I: INTRODUCTION

Background

1. The objective of a wastewater collection system is to convey wastes from the point of generation to the point of treatment or disposal. Depending on site conditions and cost of construction, the US Army Corps of Engineers (CE) has traditionally used either trucked transport or gravity pipe systems for collection and transmission of wastewaters (Cullinane 1981). The use of trucked transport systems is limited to the collection and transport of small volumes of wastewater such as septic tank sludge, vault toilet wastes, recirculating and portable chemical toilet wastes, and isolated low volume flush toilet wastes. Gravity pipe systems, on the other hand, are the systems of choice in the majority of cases where waterborne sewerage is provided.

2. Gravity sewer systems consist of a network of underground pipes that slope continually downhill to some termination point such as a discharge into a treatment plant or a regional sewer system. To obtain proper flow velocities, piping must be installed with sufficient slope in spite of the topographic and geologic characteristics of the site. Gravity systems also usually incorporate lift stations and force mains to avoid deep excavations that would be necessary in flat or undulating terrain.

3. Unfortunately, the topography and geology of many CE recreation areas are complex and not well suited for economical use of gravity wastewater collection systems. The very characteristics that make for an aesthetically pleasing recreation area often complicate the design and construction of necessary sanitary facilities. Hilly or rocky terrain may increase the cost of construction of traditionally designed gravity sewer systems, making otherwise desirable locations unsuitable for development as recreation areas (Office, Chief of Engineers, 1980).

4. Various innovative/alternative (I/A) wastewater collection technologies have been proposed and/or developed for municipal applications where topographic, geologic, or development density constraints had previously been found to make gravity collection systems economically infeasible

(Cullinane 1981). Three I/A collection and transport systems have been identified as viable alternatives in the municipal sector (National Utility Contractors Association 1979): low pressure-small diameter systems, vacuum systems, and small diameter gravity systems. To date, low pressure sewer systems have received the most attention and appear to have the most applicability to CE recreation area facilities.

#### Purpose and Scope

5. One of the purposes of Work Unit 31687, "Innovative/Alternative Wastewater Collection, Transportation, and Treatment Systems for Recreation Areas," is to develop and disseminate information concerning the applicability of I/A wastewater collection systems to the requirements of CE recreation areas. This report presents a summary of design criteria and standards for the construction of low pressure sewer systems at CE recreation area facilities. The contents of this report are intended to supplement existing CE design guidance (EM 1110-2-501, Part 2 of 3).

#### Organization of Report

6. The remainder of this report is organized into six primary parts generally described below:

- a. Part II. Part II provides a general overview of the concepts and planning criteria for the design of low pressure sewer systems.
- b. Part III. Part III presents a detailed analysis of various design flow development techniques and provides currently available information concerning the wastewater generation characteristics of various CE recreation area sanitary facilities.
- c. Part IV. Part IV describes design procedures and criteria for construction of onsite facilities associated with low pressure sewer systems. These facilities include onsite pressurization units as well as onsite piping and appurtenances.
- d. Part V. Part V discusses the design and construction of the major offsite facilities associated with low pressure sewer systems. These facilities primarily consist of offsite piping and appurtenances.
- e. Part VI. Part VI presents a summary of planning level cost estimates for various components of a low pressure sewer system.
- f. Part VII. Part VII discusses the applicability of low pressure sewer systems in CE recreation areas and presents a general summary of the report.

## PART II: GENERAL DESIGN CONSIDERATIONS

### Background

7. A gravity flow sewer system is usually considered first when water-borne waste disposal is to be provided at a CE recreation area. Unfortunately, unique site-specific constraints found at many CE recreation areas, such as topography, geology, low population density, and intermittent system use, discourage consideration of conventional gravity flow concepts. Pressure collection systems using low pressures provided by small pumps to assist in the collection and transmission of the generated wastewaters have been proposed as a solution to the limitations associated with conventional gravity sewer system design.

8. Pressure sewer systems are analogous to potable water distribution systems operating in reverse (Kriessel, Cooper, and Reyek 1977). A pressurization unit is required at each point of entry of the wastewater into the collection system. The collection system eventually empties the waste into a larger pumping station or wastewater treatment facility. Because pressure sewers transmit wastes independent of terrain constraints, they are most commonly used for lakeside communities where flow must travel uphill, areas with very hilly or very flat terrain, or areas where excavation is hindered by high water tables or rock formations. The primary advantage reported for pressure sewer systems is the reduction in excavation and pipe installation costs. This advantage is somewhat offset because of the construction, operation, and maintenance costs associated with the installation of PU's at each service connection.

9. Positive pressure sewer systems eliminate the need to lay collection system piping to strict hydraulic grade lines and the necessity for intermediate pumping stations that are often associated with conventional gravity collection systems. Smaller diameter polyvinyl chloride (PVC) pipe is substituted for larger diameter PVC, vitrified clay, or concrete pipe generally used in gravity systems. Typical pipe sizes for a pressure sewer system range between 1-1/2 and 3 in.<sup>2</sup> Pipe sizes up to 6 in. may be appropriate for 4

\* A table of factors for converting US customary units of measurement to metric (SI) is presented on page 9.

recreation area use; however, the actual size selected is a function of the design flow of the system.

10. The use of relatively small diameter PVC pipe with solvent welded or compression joints, the absence of manholes, and the low-pressure environment virtually eliminate infiltration/inflow in pressure sewer systems. On the other hand, because of the small pipe sizes, pressure sewer systems are more susceptible to hydraulic design errors and may have limited capabilities for expansion. As a result, a more detailed assessment of system requirements should be conducted during the planning and preliminary design phases if use of a pressure sewer system is selected for a particular site.

#### System Components

11. Pressure sewer systems have two basic components: offsite small-diameter pressurized collectors and an onsite pressurization system.

Offsite pressurized collectors

12. One of the first tasks in the design of a pressure sewer system is the preparation of a system schematic. In developing the initial system layout, the designer should attempt to minimize the length of the required sewer. It should be remembered, however, that pressure sewer systems can follow a relatively unconstrained alignment.

13. As a result, the designer has much greater latitude in developing the system alignment. The lower construction cost per linear foot also allows the designer more flexibility in system design.

14. Several factors should be considered in developing a preliminary layout of a pressure sewer system:

- a. Site environment.
- b. Right-of-way, access, and easements.
- c. Resident and traffic disruption.
- d. Potential for main breakage, repair time, and number of users affected.
- e. Sustaining pressures in the system.
- f. Prevention of air entrainment.
- g. Horizontal and vertical alignment.

One of the main concerns in the layout and alignment of pressure sewer systems is the maintenance of positive pressure in the system. The maintenance of positive pressure prevents the plugging of solids and grease, potential air accumulation

requires knowledge of the number of visitors, types of facilities, and required peaking factors. The average daily flow from a facility is calculated as the product of design visitation and estimated average daily wastewater generation per visitor. The design should be based on the peak visitation day estimated for the facility. An additional peaking factor must be applied to determine peak hourly design flows for pressure sewer system pumping units.

51. Over the years, surprisingly little definitive guidance has been developed concerning water usage and wastewater generation at recreation areas. Francinques and Green (1976) investigated water use and wastewater generation at the North Abutment Recreation Area, Arkabutla Lake, Mississippi. Table 8 summarizes wastewater production at a CE camping area.

52. A more recent study (Nills 1983) investigated water usage at two CE recreation areas on Greers Ferry Lake near Heber Springs, Arkansas. The study analyzed water usage at toilet/shower facilities. Because of data collection deficiencies, the study only developed a range of per capita water usage. Average daily per capita use was found to range between 5 and 44 gal per day depending on the season. Figure 9 illustrates the average daily per capita

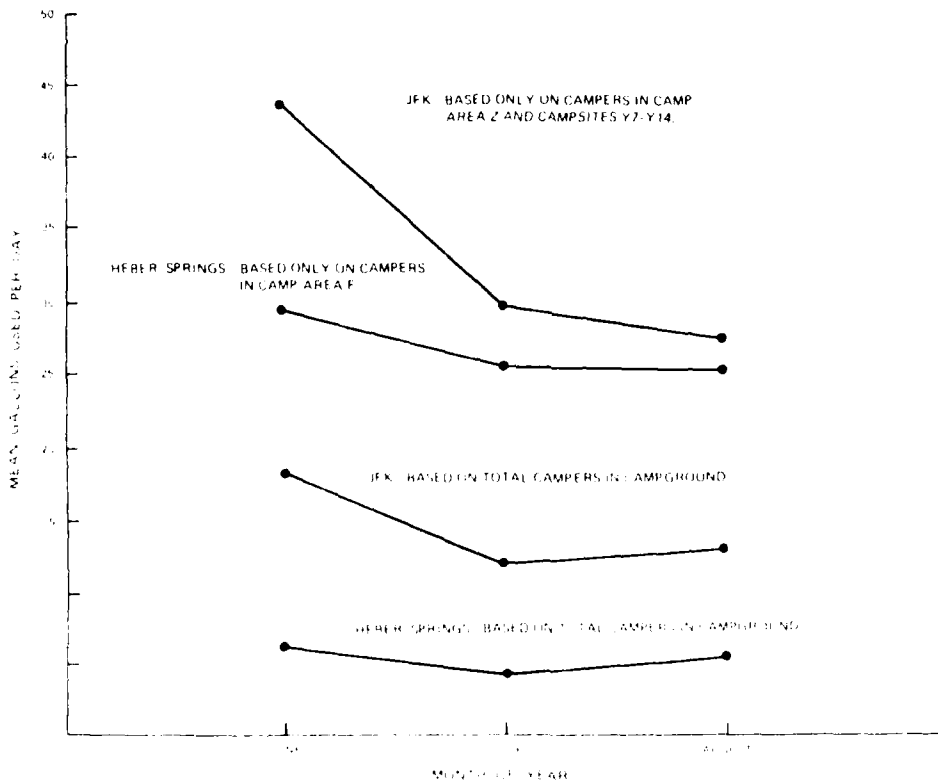

Figure 9. Mean daily water use at JFK and Heber Springs recreation areas

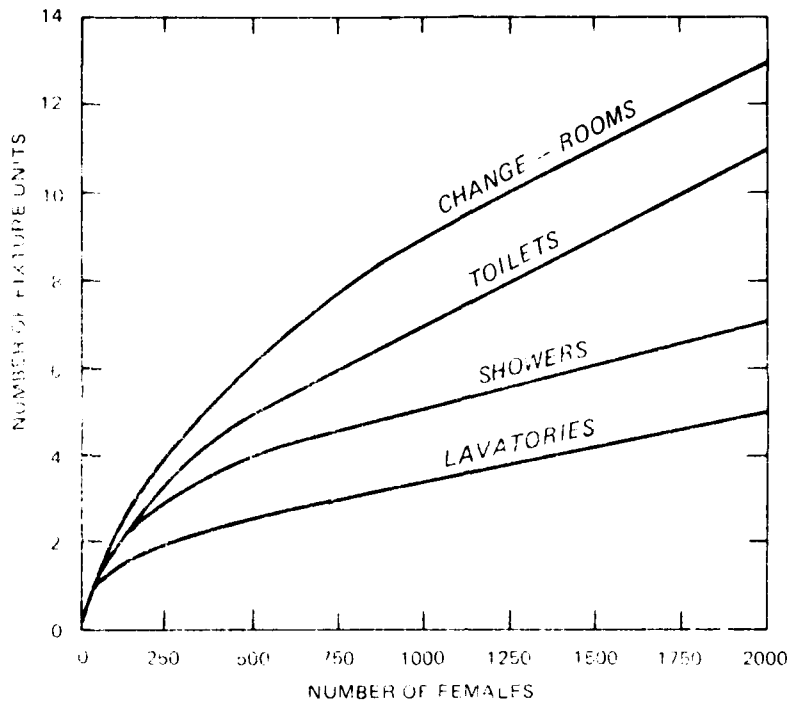

Figure 8. Fixture units for a female bathhouse

provides an estimate of the minimum number of fixtures required based on the number of camping or picnic sites.

49. When using the fixture unit basis, the engineer or planner must allow for special features such as trailer hookups and wastewater disposal stations, which may be included in the per capita use rate but which do not appear when the fixture unit method is used. The engineer should also realize that the fixture unit rate, presented in Table 5, is an hourly rate generally used to estimate total daily flow and may not be directly related to fixture units as usually used in plumbing codes to determine pipe sizes. Also, some caution should also be used in applying the fixture unit basis since it is valid only when fixtures are properly proportioned to user population. Areas where use is limited and minimum fixture comfort stations are provided can indicate several times the actual requirements if the fixture unit method is followed blindly.

#### Per Capita Use Method

50. The per capita use method of calculating design flows is based on the development of a daily water use or wastewater generation rate for a recreation area visitor. The per capita use method of design flow calculation



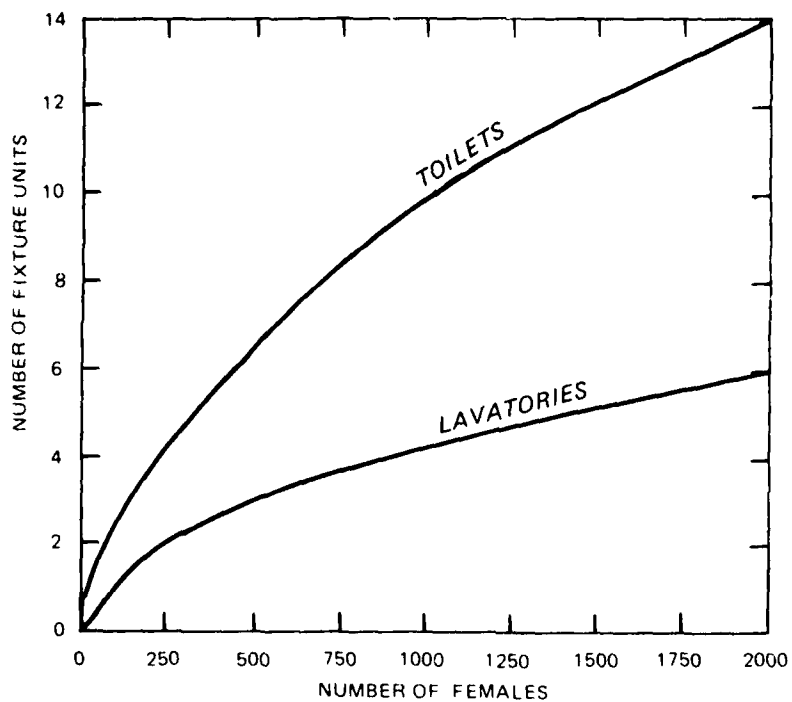

Figure 6. Fixture units for a female comfort station

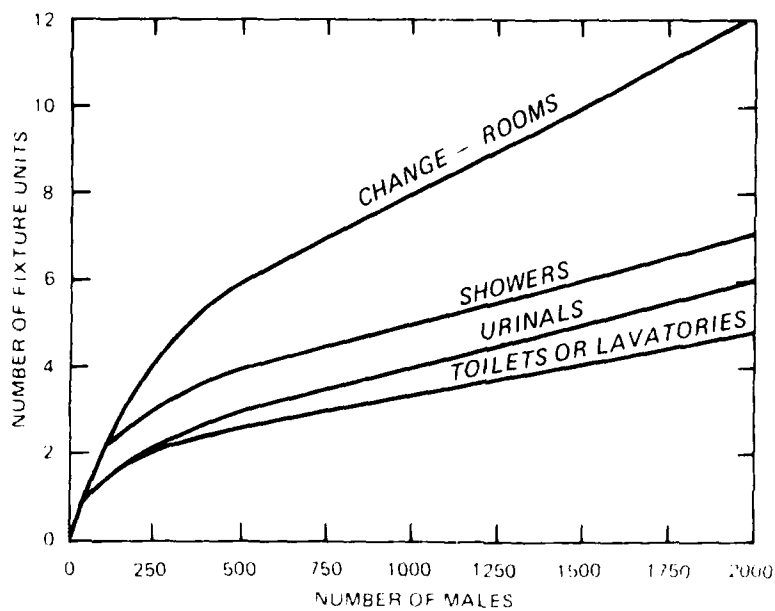

Figure 7. Fixture units for a male bathhouse

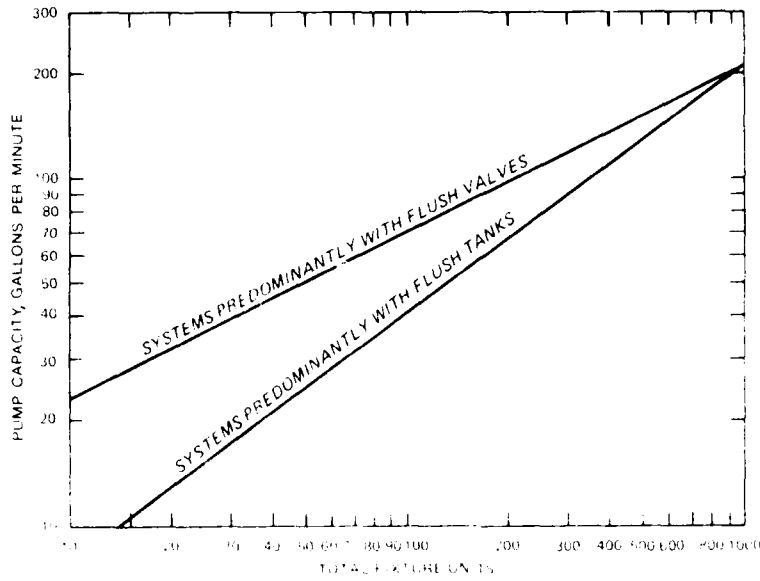

Figure 4. Pump capacity based on total value of fixture units

8. Before applying the fixture unit method, the engineer or planner may wish to check the facility's design. Figures 5 through 8 may be used to compute fixture requirements on the basis of anticipated visitation. Table 7 provides an estimate of the minimum number of fixtures required based on the number of camping or picnic sites.

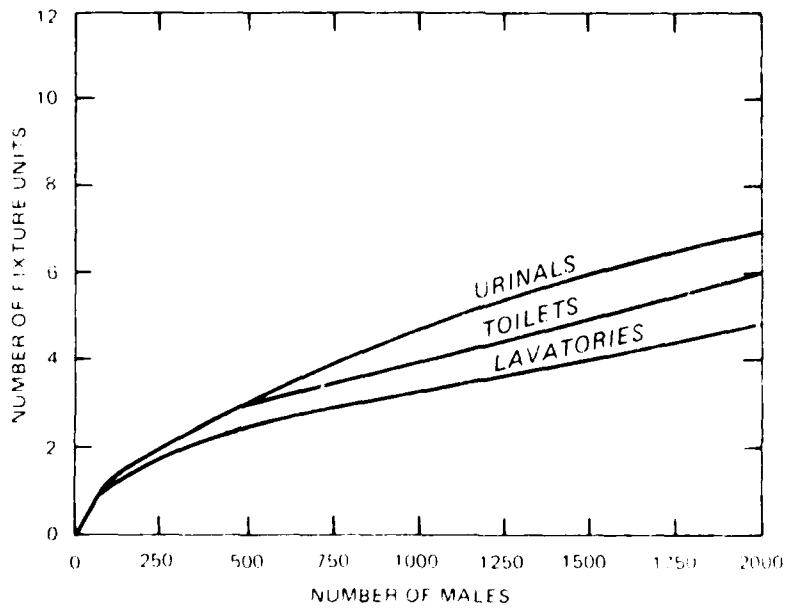

Figure 5. Fixture units for a male comfort station

## PART III: DESIGN FLOWS

### Background

44. The major design parameter for low pressure sewer systems is the peak flow generated by the type of facility and the number of people being served by the system. To a lesser degree, some consideration must also be given to the various physical and chemical constituents contained in the wastewater. Water usage rates, wastewater production rates, and wastewater characterization data have been well documented for domestic sewage generated from the municipal environment. These data, however, are not well documented for small waste-generating facilities such as those found in CE recreation areas.

45. There are two basic approaches to determining sewage flow rates from recreation areas: the fixture unit method and the per capita use method (Office, Chief of Engineers, 1980). Each of these methods has limitations and should be used with caution when developing design flows for recreation area low pressure sewer systems. Detailed procedures for the application of both methods, as well as design examples are presented in EM 1110-2-501, Part 2 of 3 (Office, Chief of Engineers 1980).

### Fixture Unit Method

46. The fixture unit method of calculating design flows is based on the development of an hourly use rate for each type of fixture proposed for installation. The fixture use method of design flow calculation requires knowledge of the number of fixtures to be installed, the type of fixtures to be installed, and the duration of use for which the facilities are designed.

47. It can be used to predict wastewater flows on the basis of the number of fixtures used (Pennsylvania Bureau of Resources Programming 1972, US Department of Interior 1984).

48. The E. I. DuPont Company (1984) provides general guidance on selecting required pump capacities for pressure sewer installations. This method uses a fixture unit value table (Table 6) and a chart (Figure 4) to develop required pumping capacities. The total number of fixtures of each type is calculated and multiplied by the value listed in Table 6 for the specific type of fixture. The total value is then used in Figure 4 to determine pump capacity. This

warning signs along the sewer route, off set markings, and inductive wire burial with the pipe are effective measures in eliminating pressure sewer main breakage and reducing repair times should breakage occur.

#### Summary

42. The previous sections of Part II have provided a general overview of the basic concepts associated with the design of low pressure sewer systems. Although the design of a particular system is site-specific, there are certain aspects of the design that are common to all situations. A basic sequence for design of low pressure sewer systems is presented below (Florida Department of Environmental Regulation 1981):

- a. Determine required data for the planning area including the location of buildings to be served, types of buildings to be served, population to be served (present and design), water use, geotechnical data (soils profiles), ground-water and surface water characteristics, wastewater treatment requirements, climate, and topography.
- b. Compile Federal, state, and local regulations that may be applicable to the site.
- c. Evaluate alternative treatment plant designs and locations and choose the most cost-effective.
- d. Prepare a preliminary layout of pressure sewer mains based on minimized pipe lengths.
- e. Locate and determine minimum quantity of air-release and pressure-sustaining valves, in-line and terminal cleanouts, and main line shut-off valves.
- f. Determine design flows.
- g. Perform hydraulic analyses to determine pipe sizes, transition points, and valve and cleanout locations.
- h. Analyze alternative onsite components with respect to the pressurization unit, control and alarm equipment, contingency plans, residuals disposal plan, and capital and operating costs. Determine the most cost-effective, generic onsite system.
- i. Prepare detailed plans and specifications including operation and maintenance plans for the proposed system.
- j. Review plans and specifications with appropriate approval agencies.

43. The above step-by-step procedure helps to ensure that the proposed systems are efficiently designed and constructed. In addition, the development of the preliminary operation and maintenance plan ensures that the system is both operable and maintainable.

38. The wastewater treatment aspects of pressure sewer systems are probably the least studied. However, the two most commonly used systems from which information is available have reported in major journals (Kilham, Cooper, and Kevsek, 1977) some additional pertinent information. There is a major difference in treatment requirement between septic tank-effluent pumping and grinder pump systems. In the former, only relatively weak wastewater in terms of  $BOD_5$  and suspended solids must be treated via infiltration and maintenance in the form of septic tank pumping and septage disposal is required. In the latter case, a very concentrated waste in terms of  $BOD_5$  and SS must be treated. The trade-offs between the two must be weighed by the designer.

#### Contingency Planning

39. The contingency needs for grinder pump units are greater than for septic tank-effluent pumping units. The greater onsite storage capacities of septic tank-effluent pumping systems reduce operation and maintenance personnel requirements by permitting repairs to be made during normal working hours and minimizing the need for extra working shifts and associated additional manpower. Connection to abandoned soil-absorption systems where ground-water conditions are favorable, enlarged pump chambers and wetwells with quick disconnect arrangements, and adjoining overflow tanks with gravity drainage back to the wetwell during normal operation are possible contingency solutions that are simple and economical to implement.

40. The general requirement for contingency planning is to provide storage for an average day of flow. The exact contingency requirement is subject to local conditions and some judgment is required. Most contingency planning criteria are based on residential systems with little resemblance to CB recreation area characteristics. Consideration should be given to such factors as the critical nature of the facility and the estimated repair times. Repair times should include the possibility of pump breakdowns as well as a break in the pressure sewer service lines and mains.

41. Although primary attention will focus on pumping system malfunctions, problems associated with pressure sewer main construction must also be anticipated. Location of pressure sewer mains in areas where damage is less likely, provision of detailed and accurate architect-contractor's plans,

<u>Component</u>	<u>Recommended Material of Construction</u>
Pump impellers	Plastic, bronze, cast iron
Appurtenances	Plastic, 316 stainless steel

31. Electrical connections to the main panel should be constructed in accordance with appropriate electrical and construction codes. Approved underground wiring is recommended for both pump and control circuits. Separate fuses or circuit breakers should be provided. Control systems should be located in full view of the pressurization unit and placed in a lockable tamperproof and weatherproof circuit breaker box. The pump panel should have a smaller fuse or breaker than the service panel. The pump motor connections should be watertight.

32. The potential for power outages at CE recreation areas requires consideration of reserve holding capacity, either in the grinder pump wetwell or the septic tank in the septic tank-effluent pumping system. Depending on the site, the loss of power may not be critical if the water supply to the site also terminates when the power fails.

33. In those cases where several facilities are to be served by the pressure sewer system, consideration should be given to the use of hydraulically similar pressurization equipment. Use of similar equipment will simplify both design and operation and maintenance tasks. Spare parts and equipment inventories should be maintained based on system maintenance experience. No guidance is available for recreation area facilities; however, the tabulation below provides guidance on systems serving residential developments.

<u>Pressurization Units Installed</u>	<u>Number of Spare Units Required</u>
1-10	1
10-20	2
20-40	3
40-60	4
60-100	5
100-200	6
>200	3%

34. The typical CE recreation area should have one spare for each type of pressurization unit installed. Additional spare parts requirements should be developed based on system operating experience.

26. Serviceability of the onsite components is important to both minimize the time lost because of equipment malfunctions and to keep the cost of inspection and maintenance to a minimum. Quick disconnect features are recommended for both piping and electrical connections so that the pressurization unit can be quickly removed for inspection, repair, or replacement. For shallow wetwell installations (less than 3 ft), a simple union arrangement is often acceptable. For deeper wetwells, slide-away coupling arrangements with slide rail and lifting chains should be considered. Complete packages are generally employed which incorporate simplified removal arrangements.

27. Safety problems associated with pressure sewer systems in CE recreation areas are generally related to the protection of the visitor and maintenance personnel.

28. One of the more frequent concerns is that of unauthorized access to the pressurization unit. This concern can be alleviated by incorporating a locking mechanism on the wetwell cover. Only authorized maintenance personnel should be able to obtain access to the pressurization unit.

29. In addition to normal safety considerations, maintenance personnel should be particularly aware of the potential of falls in deep wetwells and the accumulation of toxic or explosive gases in the wetwell. Proper venting of the wetwell can minimize the potential for accumulation of hazardous and potentially explosive gases. Emergency pressure relief devices should also be incorporated in the design.

30. Materials of construction must be capable of withstanding the environmental conditions of service. Grinder pump systems are generally packaged by the manufacturer in such a manner that these considerations have been incorporated at the factory. Septic tank-effluent pumping systems are generally locally designed and field erected, thus requiring the designer to be more cognizant of the highly corrosive nature of septic tank effluent. All components of the septic tank-effluent pumping system exposed to the atmosphere must be highly resistant to corrosion. Materials that have been found to be acceptable for various system components are listed below:

Component	Recommended Material of Construction
Septic tank and wetwell	Concrete, plastic, coated steel
Valves	Bronze, plastic
Pump housing	Cast iron, plastic, bronze, coated cast iron

(Continued)

designing pressure sewer systems are similar to those of conventional gravity sewers. At a minimum, the following information should be developed before final design (Peabody Barnes, Inc., 1977).

- a. Topographic map of the area to be served.
- b. Site plan indicating locations of wastewater generating facilities.
- c. Geologic conditions including soil and water table conditions.
- d. Location of wastewater treatment plant.
- e. Types and capacities of wastewater generating facilities to be served.
- f. Climatic conditions (frostline).
- g. Location of present utilities including sewer systems.
- h. Power requirements, location of existing power sources, and power outage data.
- i. Applicable local, state, and Federal codes and construction criteria.
- j. Type of system (total pressure or pressure-gravity combination) and proposed system layout.

23. The major capital and operation and maintenance costs of pressure sewer systems are usually related to the onsite pressurization facilities.

Factors affecting onsite component design include:

- a. Type of pressurization system selected.
- b. Single versus multiple service.
- c. Location of the pressurization system.
- d. Alarms and control systems.
- e. Aesthetics and safety.
- f. Component serviceability.
- g. Materials of construction.
- h. Electrical requirements.

24. The first basic design decision is the specification of the generic type of pressurization unit. This decision affects the remainder of the system design. Unless local conditions preclude one of the two primary alternatives, both the grinder pump and septic tank effluent pump system should be evaluated. Table 1 presents a qualitative comparison of the two systems.

25. Economics tend to favor multiple services per pressurization unit if the sources of wastewater are within reasonable proximity. The cost-effective separation distance is a function of local construction costs and system design.



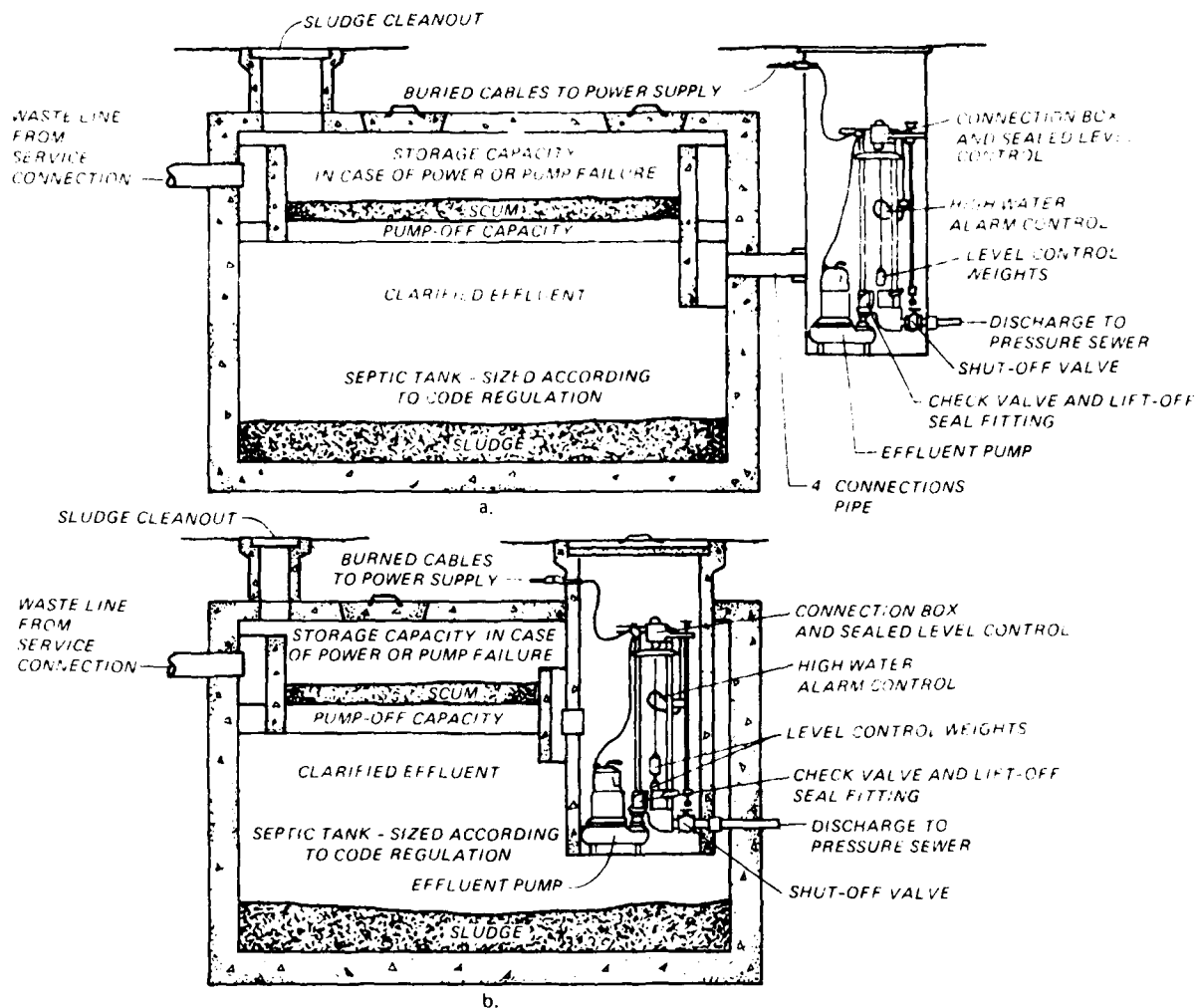

Figure 3. Typical septic tank-effluent pumping pressurization unit installation

essence, the septic tank-effluent pumping concept removes large solids and other materials via sedimentation rather than reducing the size of the objects by grinding as in the case of the grinder pump system. Because septic tank-effluent pumping pumps handle only supernatant from the septic tanks, these pumps are generally smaller and require less maintenance than grinder pumps.

#### Design Factors

22. The initial step in planning for the use of a low pressure sewer system is to define the area to be served and inventory the wastewater collection and treatment requirements. Information requirements for planning and

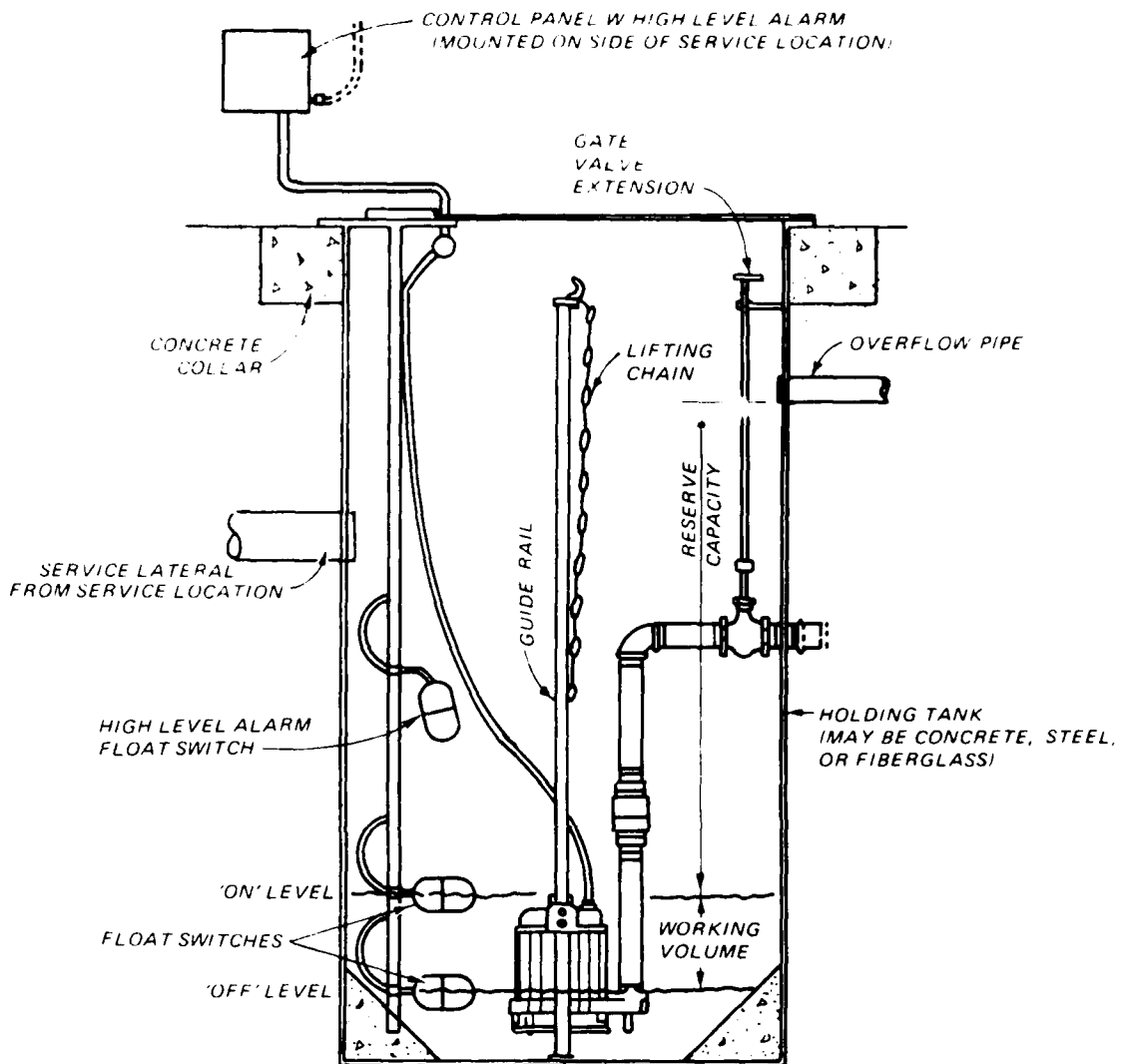

Figure 2. Typical grinder pump pressurization unit installation

21. Septic tank effluent pumping systems. Septic tank-effluent pumping systems consist of a conventional septic tank, the onsite pressurization unit, and the collection system piping. In the septic tank-effluent pumping system, wastewaters are collected by the building sewer and transported to a septic tank. The pressurization unit may be placed either inside the septic tank or outside the septic tank in a separate structure. Figure 3 illustrates a typical septic tank-effluent pumping system installation. The septic tank provides significant levels of treatment by removing from 80 to 90 percent of the grease, 70 to 90 percent of the suspended solids, and 50 to 80 percent of the biochemical oxygen demand (BOD) (Kriessell, Cooper, and Reyek 1977). In

system. Two basic concepts are available for pressurization unit design. The first uses a grinder pump to grind the wastes into a slurry and then pump the slurry through the piping system. The second concept is the septic tank-effluent pumping system. The septic tank-effluent pumping system concept employs a septic tank for anaerobic treatment and removal of gross solids from the wastewater prior to injection of the wastes into the collection system with small centrifugal pumps. Figure 1 illustrates the typical components of a pressure sewer system.

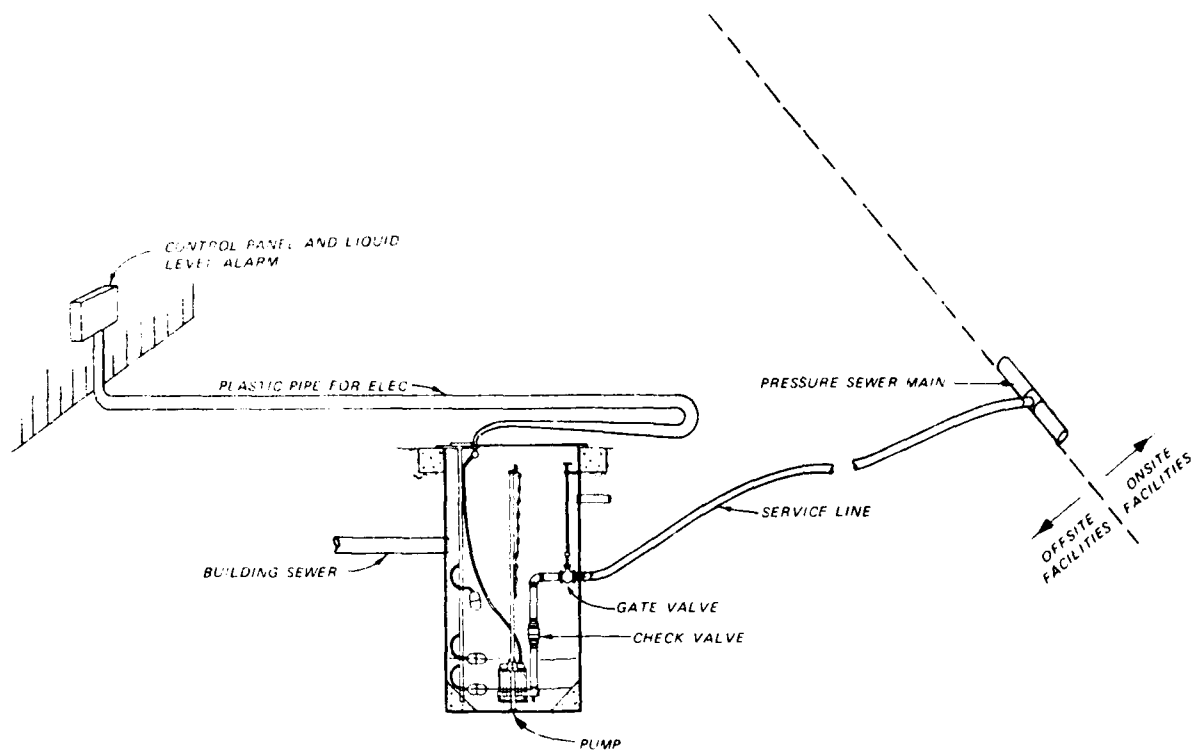

Figure 1. Typical components of pressure sewer systems

20. Grinder pump systems. Grinder pump systems usually consist of a holding tank, the grinder pump, associated electrical and mechanical appurtenances, building sewer, service line, and collection system piping (Hydr-O-Matic Pumps 1978). The grinder pump is installed slightly above the bottom of the holding tank, which may be located in a building basement or separate structure. The holding tank receives wastewater flows by gravity. Level sensors activate the grinder pump operation pump at preset levels. Emergency overflow and high water level alarms are also generally provided. Figure 2 illustrates a typical grinder pump installation.

at high points, and possible siphoning effects on pumping units (Peabody Barnes, Inc., 1977). Positive pressures can be maintained through the use of positive pressure regulating valves or by locating the system terminals at the highest point in the system.

15. Air accumulation at system high points can have a detrimental effect on the operation of pressure sewer systems. The number of high points in the system can be minimized by installing piping on a uniform grade where possible. Precise survey profiles, however, are not required. Although air accumulated at system high points can be purged if sufficient wastewater velocities are maintained, some form of positive air relief at major high points should be provided (Hydi-O-Matic Pumps 1978).

16. The selection of an appropriate horizontal alignment for the proposed pressure sewer system is primarily a function of the location of facilities to be served. The normal CE recreation area will have a limited number of facilities to be served when compared to a residential development using pressure sewer systems. As a result, system alignment should be simplified.

17. Residential applications of pressure sewer systems have been based on either dendriform or grid layouts. Dendriform layouts usually require the least amount of pressure sewer main construction; however, any damage to the main sewer interrupts service to all upstream connections. Grid layouts overcome the loss of service problems, but result in uneven flow patterns which adversely affect scouring velocities and thus may be detrimental to proper functioning of the system.

18. A compromise to either the dendriform or grid layout has been the clustered feeder approach, where smaller branched systems service multiple connections and feed into a main sewer. In this design, service of mainline breakage is more likely to affect only the particular cluster in which breakage occurs and flows would remain predictable as in the dendriform layout. A reduction in the number of anticipated service interruptions can also be accomplished by the installation of connector lines between clusters. The connector line would normally be valved from service; however, the connector line could be opened to service if necessary to provide continuous service. Onsite pressurization system.

19. The onsite pressurization unit serves two basic functions: removing objects capable of lodging in the small-diameter piping system and providing the pressure necessary to drive the wastewater through the piping.

water consumption for the two sites investigated. An important aspect of the Mills study is the development of hourly per capita use rates. These rates are presented in Figures 10-13.

53. In addition to the Francingues and Green (1976) and Mills (1983) studies, various other sources of guidance on water use in recreation areas are available. Table 9 presents basic information for the calculation of daily per capita wastewater generation rates. The quantities presented in Table 9 agree with water usage values reported for various CE recreation areas. Tables 10 and 11 may also be used as additional guidance where site-specific data are not available. It should be remembered that in a zero infiltration system, such as found in low-pressure sewer systems, water usage may be reduced by up to 20 percent to determine average daily wastewater flows.

54. Estimating visitation is another important variable in the use of the per capita method for generation of wastewater flows. Although visitation estimation is more art than science, standardized techniques have been developed. Mischon and Wyatt (1979) provide general guidance on calculating attendance at CE recreation areas. Research is currently under way to update and standardize appropriate procedures.\* For existing recreation areas, an estimate of design population estimates can be obtained from current visitation records. For proposed facilities, the visitation records of comparable recreation areas at other projects can be reviewed.

55. Although the per capita use method for generating wastewater flows has been very popular, the method is more suited for estimating average or peak daily flows rather than the peak minute or peak hourly flows required for proper design of pressure sewer systems. The fixture unit method of design flow estimation provides a better estimate of the peak hourly flows needed for design purposes. However, the per capita use method can be used as a general check of flow projections generated by the fixture unit method to ensure reasonable, cost-effective designs.

\* Personal Communication, January 1984, R. Scott Jackson, Outdoor Recreation Planner, US Army Engineer Waterways Experiment Station, Vicksburg, Mississippi.

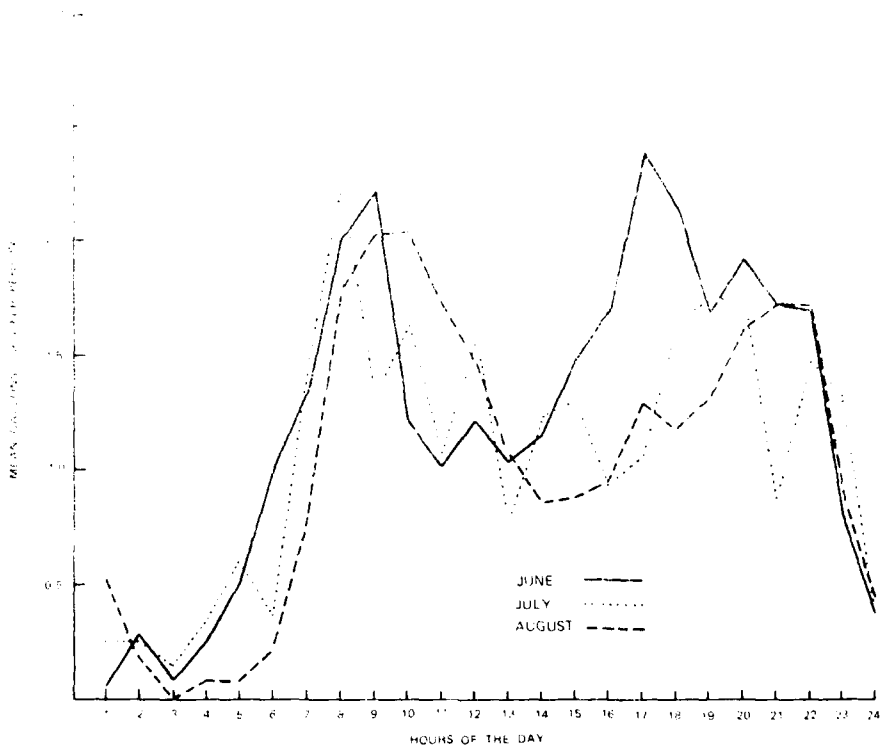

Figure 10. Mean hourly water use for Loop F campground at Heber Springs recreation area

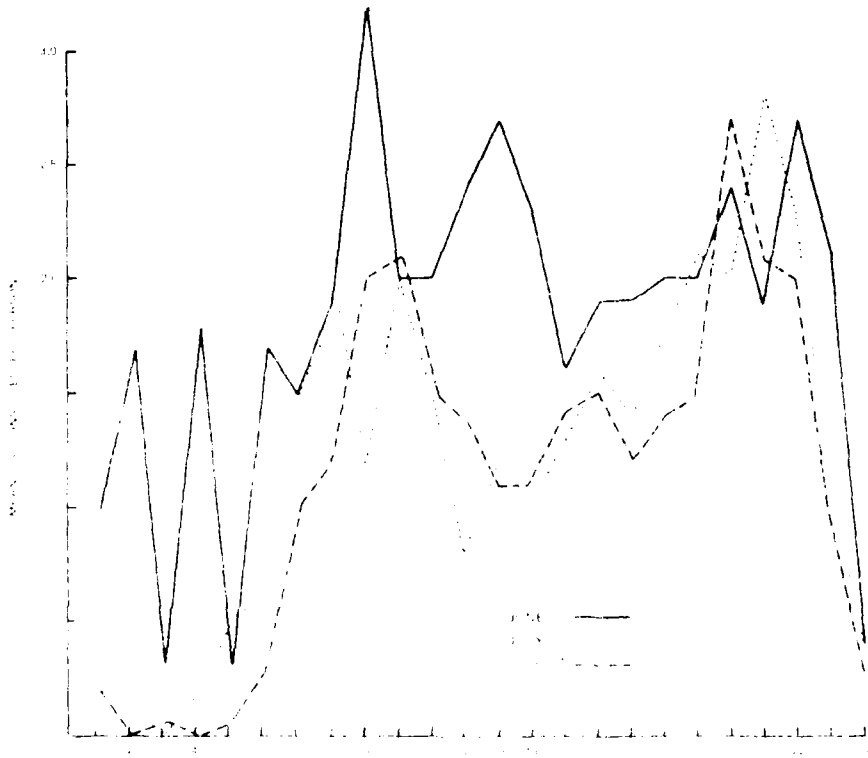

Figure 11. Mean hourly water use for Loop A and Loop B campgrounds at Heber Springs recreation area

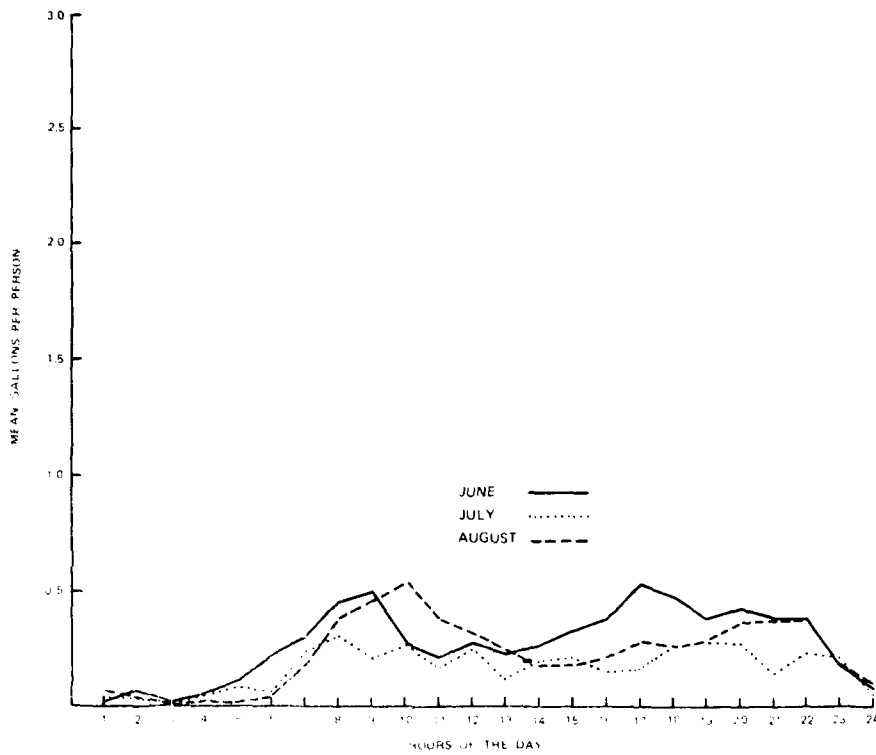

Figure 12. Mean hourly water use for all campsites at Heber recreation area

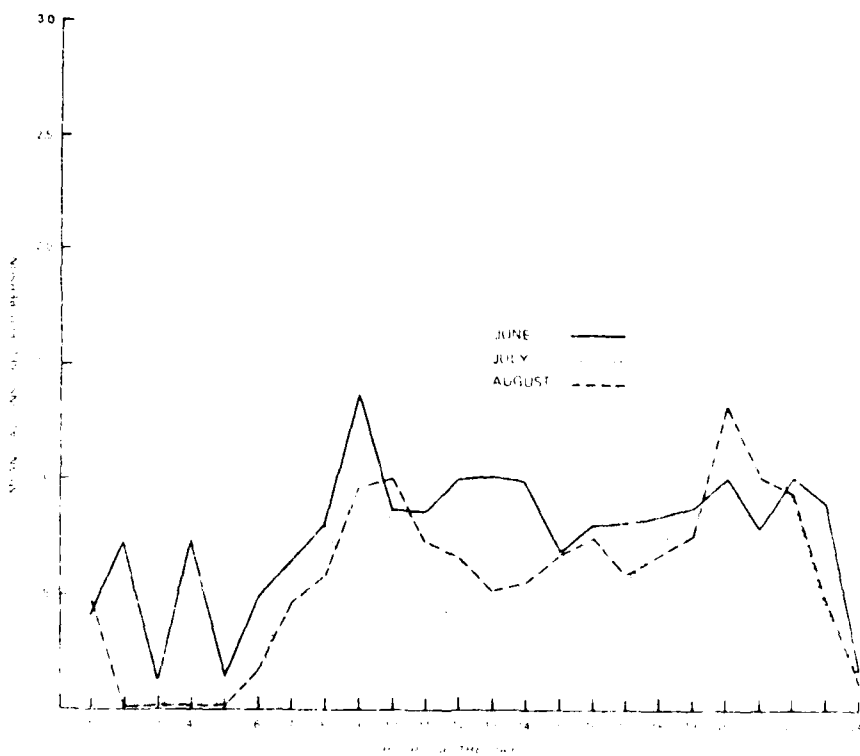

Figure 13. Mean hourly water use for all campsites at Jik recreation area

## PART IV: ONSITE FACILITY CONSTRUCTION

### Background

56. Onsite facility construction includes those facilities that must be constructed immediately adjacent to the point of wastewater generation. In traditional pressure sewer construction oriented towards providing service to a residence, onsite construction refers to the facilities that are constructed on the individual property owner's lot. This definition is not suitable for application to the construction of pressure sewers at recreation areas; therefore, a somewhat artificial definition must be developed. For purposes of this study, onsite facility construction is defined as those facilities that must be constructed between the point of wastewater generation and the pressure sewer main. Specifically, onsite facilities include: septic tank and/or wetwell, pressurization unit, service connection, and all structural and electrical appurtenances thereto.

### Septic Tank and Wetwell

#### Sizing

57. Septic tank. Septic tank sizing is normally based on a specified detention time, a function of wastewater flow. Detention time in a septic tank should be a minimum of 10 hr. When septic tanks are used in conjunction with a surface drainage field, a minimum of 24 hr detention time based on average flows is usually recommended. The septic tank must not only provide the required detention for the design flow but must also include an additional capacity for sludge storage and any reserve storage requirements. For systems larger than 1500 gal/day may be determined by the following equation (Duro, Chief of Engineers 1984):

$$V = 1,125 + 0.75q \quad (1)$$

#### Terms

- V = required tank capacity, gal
- q = average sewage flow, gal/day

58. Figure 14 gives the required volume of septic tank for a given flow rate.



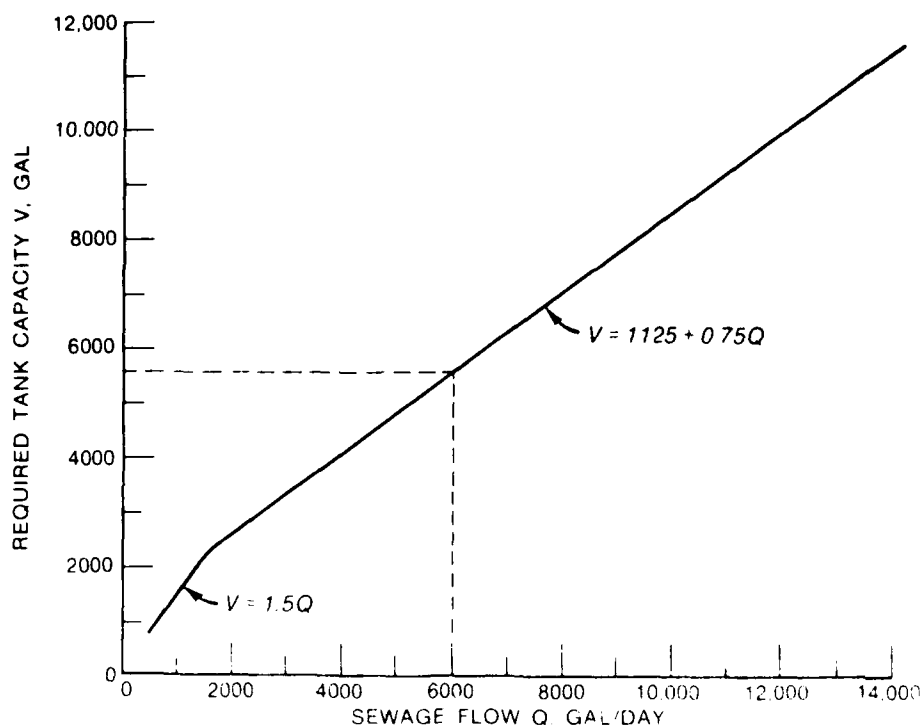

Figure 14. Volume of septic tank for various design flows

59. In addition to the additional volume required for sludge storage, it is also desirable to include some reserve capacity in case of pressurization unit or power failure. Figure 3 illustrates the freeboard within a septic tank that is usually available for reserve storage. Additional storage can be provided if deemed necessary.

60. Wetwell. Wetwell sizing is normally a function of the wastewater generating facility being served, pressurization unit hydraulic characteristics, and desired reserve capacity. Reserve capacity is the volume available for storage between the elevations of the high water alarm float switch and the invert of the overflow pipe. Typical wetwell reserve capacity for a residential installation is 50 gal. For recreation area applications, reserve capacity requirements can be estimated as the product of the hourly wastewater generation rate and the length of time that it will take to replace a pressurization unit. A 1-day (8-hr) holding capacity is usually sufficient.

#### Structural design and materials

61. Structural design. The structural design of septic tanks must consider soil loading resulting from their buried installation, hydrostatic

loadings that may occur because of high water tables, and external loads that may result from vehicular traffic. Loads on septic tank and wetwell walls, floors, and roofs should be evaluated. Septic tanks are usually located in areas not subject to vehicular traffic; however, a vehicle may occasionally pass over the tank and, therefore, the septic tank roof should have sufficient strength to resist collapse. All septic tanks should have an approved structural design.

62. Materials. Prefabricated septic tanks in standard sizes are available in three basic materials: concrete, plastic, and steel. For larger non-residential sizes the choices are probably limited to concrete or steel.

63. The most common material of construction for septic tanks is concrete. Concrete septic tanks should be constructed in accordance with recommendations of the American Concrete Institute or an approved equal. Concrete has proven to be a very durable material for septic tank construction. Weibull, Straub, and Thoman (1949) conducted a study of 150 concrete septic tanks ranging in age from 0.5 to 39 years of age. Of the 150 tanks inspected, 91 percent were judged to be in good to excellent structural condition. Corrosion at or above the water line was found in some tanks.

64. Septic tanks are available in three plastic materials: fiberglass, polyethylene, and acrylonitrile-butadiene-styrene (ABS). Fiberglass-reinforced plastic is probably the most common. Fiberglass septic tanks should be constructed in accordance with American Society of Testing and Materials (ASTM) D3299 or International Association of Plumbing and Mechanical Officials IGC-74 as applicable. Wall and bottom thicknesses should be determined from a structural evaluation of the most severe structural loading conditions. Because of their light weight, hydrostatic loads are of particular importance in the design of plastic septic tanks. The need for antifoatation measures should be specifically evaluated for all plastic septic tank installations.

65. Common carbon steel with coal tar epoxy coatings has also been used for the construction of both wetwells and septic tanks.

66. The impact of corrosion on the materials used for septic tank and wetwell construction may be significant. The interior surfaces of septic tanks are subject to corrosion from several sources. As wastewater is retained in the septic tank for long periods of time, oxygen is depleted and anaerobic conditions develop. Hydrogen sulfide generated under these conditions is released within the tank. Bacterial organisms on moist interior

surfaces convert the hydrogen sulfide into sulfuric acid which may attack the material used for construction.

67. Various materials have been applied to the interior surfaces of septic tanks; however, many of these have shown little success in reducing corrosion. Corrosion protection is more important in steel septic tank construction than in either concrete or plastic tanks. Prior to fabrication, the steel should be sandblasted or shotblasted to a "white metal" finish as recommended by the steel structural painting specification SP-5-63 or NACE#2. After cleaning, fabrication, inspection, and spot recleaning, the surface must be coated before oxidation can reoccur. Coal tar epoxy or bituminous products are often applied in one or two coats to a dry film thickness of 8 mils. Cathodic protection may also be used in conjunction with steel tanks. Magnesium anodes are normally used for cathodic protection.

68. In addition to corrosion considerations, fiberglass has been shown to deteriorate from moisture wicking along the glass fibers should the edges become exposed to moisture. Wicking may be reduced by application of resin-rich coating or gel coat to all surfaces.

#### Installation

69. Septic tanks should be installed in accordance with sound engineering practice. The excavation backfill adjacent to the installed septic tank should be placed in 6-in. lifts, moisture to be optimum, and compacted to 90-percent relative density (AASHTO T-99 or T-180 for standard and modified proctor). Stones or debris having a diameter of 4 in. or larger should not be included in the backfill material. Backfill in the vicinity of the septic tank inlet and outlet piping should be manually placed and should consist of crushed rock or washed gravel to a depth of 6 in. over the inlet and outlet pipes with the remaining backfill placed in the same manner as that adjacent to the septic tank. Septic tanks installed in soft or yielding soils should be bedded on crushed rock or gravel having a thickness not less than 6 in. For particularly soft soils, a foundations analysis should be performed. If the area is subject to high ground water, i.e. ground water above the septic tank floor, the septic tank should be secured against flotation.

#### Testing

70. Septic tanks should be watertight and must be tested for leakage. Septic tanks should be tested for watertightness by filling with water to the soffit, left standing for 24 hr, and examined for leakage.

## Pressurization Units

### Grinder pumps

71. Two types of grinder pumps are generally available: submersible centrifugal or semipositive displacement progressive cavity. The performance of the two types of pumps is different with respect to capacities and shut-off heads. The centrifugal type pumps operate at reduced delivery at high system heads whereas the positive displacement pumps provide a constant delivery relatively independent of system heads. Figure 15 illustrates the head-discharge relationships for typical centrifugal and semipositive displacement pumps.

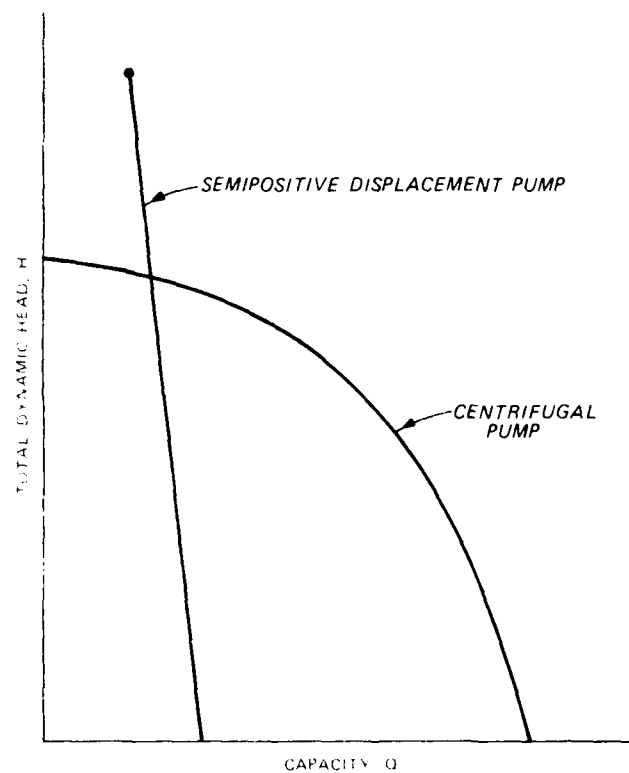

Figure 15. Typical capacity-head characteristics for centrifugal and semipositive displacement grinder pumps

72. Submersible centrifugal and semipositive displacement pumps are available in a variety of ratings. One to two horsepower pumps are normally specified for residential applications. For installations where larger flows are generated, submersible centrifugal grinder pumps are available in sizes up to and including 5 hp. The semipositive displacement pump is not presently available in sizes exceeding 1 hp.

73. The grinder pump unit (both centrifugal and semipositive displacement) must be capable of comminuting (grinding) all material expected to be found in the wastewater being handled. Reasonable amounts of foreign materials such as glass, eggshells, sanitary napkins, and disposable diapers must be ground into particles that will pass through the structure piping and downstream valves. Stationary and rotating cutter blades should be made of hardened stainless steel.

74. Both single-phase and three-phase motors are available. Single-phase motors are available for 115- and 230-v service. These motors should be of the capacitor start/capacitor run type for high starting torque. Three-phase motors are available for 208-, 203-, 460-, or 575-v service. All grinder pumps should be of standard construction. The grinder pump should be inspected to include visual inspection to confirm construction in accordance with the specifications, including: model, horsepower, cord length, impeller size, voltage, phase, and hertz. Of special importance, the pump and seal housing should be tested for moisture and insulation defects. After connection to the discharge piping, the grinder pump should be submerged and amperage readings taken in each electrical lead to check for unbalanced stator winding.

#### Effluent pumps

75. Effluent pumps are usually of the centrifugal type with a submersible motor. Typical construction may include cast iron, bronze, and/or plastic. The pump is usually mounted in the wetwell or septic tank on three integral support feet or base. Effluent pumps are available in sizes ranging from 0.25 to 2 hp. Effluent pumps with ratings up to 0.75 hp are available for either 115- or 230-v service and pumps with ratings over 0.75 hp are available for 230-v service. Effluent pumps are generally capacitor start with either permanent split capacitor or split-phase motors. Motor starters and capacitors can be located in the motor or adjacent housing. Either a control box housing or a junction box is required to connect the pump and level controls to the power source.

76. Effluent pumps should undergo the same testing as required for grinder pumps.

### Onsite Piping

#### Building sewer

77. The building sewer, also called the service connection, service

interior of the pipe. The pipe should be installed in the same manner as a gravity sewer except that the slope of the pipe should be increased to provide the desired velocity. The pipe was written for a 12-in. diameter pipe. A 12-in. diameter pipe is usually 12 in. or 8 in. in diameter installed with a slope of approximately 2 percent. (American Society of Civil Engineers, 1982). Materials of construction include PVC, vitrified clay, concrete, and ductile or cast iron. Joints and workmanship in construction of building sewers should be equivalent to those found in construction of conventional gravity sewer systems. Since the building sewer represents the major source of infiltration/inflow in pressure sewer systems, particular attention should be paid to jointing techniques and the compaction of bedding and backfill material. American Society of Civil Engineers (1982) and Illinois Society of Professional Engineers (1973) provide detailed information concerning the design, construction, and specification of gravity sanitary sewer systems.

#### Service lines

78. The service line consists of the piping and appurtenances between the pressurization unit and the pressure sewer main. Service line piping is sized to ensure the maintenance of minimum flow velocities. Service line piping usually varies between 1-1/4 and 2 in. in diameter. Small residential installations usually use 1-1/4-in. service lines which have been recognized to offer the best compromise between costs, provision of necessary scouring velocities, and minimization of head losses. The larger pump installations found at recreation area facilities will generally use the larger pipe diameters (1-1/2 and 2 in.).

79. Service lines are normally constructed with PVC pipe, although some polyethylene (PE) pipe service lines have also been installed. Both PVC Schedule 40 and Sbk-21 PVC pipe have been used for service lines. Solvent weld joints are normally used. Care must be taken in the installation of both PVC and polyethylene pipe. Manufacturer's instructions should be followed in the installation of both kinds of pipe. Other piping materials have been used for service lines, however, they are generally considered to be higher in cost than PVC construction. The location of the service line should be well marked to prevent possible damage because of future excavation or development in the area.

80. Although a check valve is normally installed on the pressurization unit's discharge piping, it is also desirable to install an additional check

valve either directly outside the pump wetwell or near the pressure sewer main connection.

81. In addition to the check valves, a gate or ball valve will normally be located in the wetwell on the discharge side of the pressurization unit. These valves serve to prevent backflow when the pressurization unit is removed from service. Maintenance on the service line is also facilitated by the installation of a corporation stop or other type of valve on the service line near the pressure sewer main.

82. Service lines must be installed at a depth sufficient to prevent damage from either mechanical loads or freezing. The installation depth depends on the site; however, a minimum depth of 1 ft is recommended. In most cases, the service line slopes upward to the pressure sewer main connection. In those cases where the service line slopes downward to the pressure main, a spring-loaded check valve should be installed in the pressurization unit wetwell to minimize the potential for siphoning problems.

83. Pressure sewer service lines and potable water supply piping should be installed with at least 10-ft horizontal separation. Where pressure sewer mains are installed on one side of a street or road, service line connections from the opposite side of the street should be installed by boring (if the roadway has been surfaced), or installed within a bored casing in heavily trafficked areas. The potable water supply line and the pressure sewer service line may be bored beneath the street surface in the same proximity provided that either line is installed in an approved casing.

84. A corporation or "V" valve should be located at the street or property line to isolate the service line from the pressure sewer main. The valve riser and cap should be located out of access of road traffic to prevent damage to the riser which could, in turn, crush the service line. Some pressure sewers do not provide a riser or valve box to locate or service the check valve located near the street on the assumption that failure would be a rare occurrence and that these components could, if necessary, be located, excavated, and repaired.

85. Service lines can be joined on the surface and then placed into the excavated trench. Pipes shall be joined in accordance with the manufacturer's printed instructions.

86. The trench should not be excavated for a distance greater than can be backfilled during the same day of excavation.

It is not expected that the service line and valves will be damaged by severe adverse normal operating conditions. Occasionally, the service line may be damaged due to mechanical excavation in the area or possibly an earth slide. If this happens, the service line can be isolated.

### Appurtenances

#### level controls

88. The operation of both grinder pump and septic tank-effluent pumping systems is controlled by measuring the level in the septic tank or the wetwell. There are four basic types of level sensors used with grinder pump and septic tank-effluent pumping systems. These include mercury level control switches, magnetic weight displacement switches, pressure-sensing switches, and diaphragm switches.

89. Mercury level control switches. Mercury level switches contain a mercury contact switch encased in a polyurethane ball. In the simplest system, three separate switches are required with each switch designated to either turn the pump on, off, or activate the high level alarm. Differential mercury switches that combine the functions of the on and off switches have recently been introduced. A separate mercury switch is still required to activate the high level alarm.

90. Magnetic weight displacement switches. On-off level is controlled by two adjustable plastic displacement weights connected to a magnetic switch. During operation, water rises in the wetwell or septic tank until about one-half of the upper weight is submerged. This reduces the weight of displacement weights by the weight of the volume of water displaced by the plastic weight. The reduced weight of the plastic weights causes a spring to release, allowing a magnetic follower to move upward and to attract a permanent magnet attached to a switch arm. This operation closes the switch and starts the pump. The pump continues to operate until about one-half of the lower weight is out of the water. The resulting increase in loading on the spring causes it to compress and pull the follower away from the magnet. This opens the switch and stops the pump. A mercury level control switch may be used for the high water alarm. The switch is contained in a sealed housing. All parts of the switch can be taken apart for replacement or maintenance without disturbing the pump or the piping.



91. Pressure-sensing switches. Pressure-sensing switches can be used in conjunction with a bubbler system to measure liquid depth and thus control the operation of the pumps. Bubbler systems measure liquid level by determining the air pressure required to force a small stream of air through the lower end of a tube extending to the bottom of the wetwell or septic tank. The back pressure in the pipe depends on the depth of liquid over the open end of the pipe. A pressure switch senses the hydrostatic pressure and activates the pump. A similar switch can be installed as a high water alarm. Bubbler systems require a source of compressed air and must be vented to the atmosphere.

92. Diaphragm switches. Pressure diaphragm box type sensors operate on the principle that air in a diaphragm box compresses as the water level rises. The diaphragm box is fixed at a location that becomes the reference point for the measurement (Metcalf and Eddy 1981). As the liquid level rises above the diaphragm, the pressure on the diaphragm compresses the air trapped in a closed tubing system connected to a pressure-sensing element. The pressure-sensing element transmits the on-off signal to the pump. The diaphragm switch can be used in septic tank-effluent pumping systems; however, it is not generally recommended for grinder pump systems because of the potential for solids buildup around the diaphragm. Diaphragm switches must be vented to the atmosphere. A second diaphragm switch, mercury switch, or pressure-sensing switch must be used if a high water alarm is installed.

#### Electrical

93. Electrical appurtenances primarily depend on the type of pump and motor selected for the installation. Additional attention must also be given to the pump and alarm system wiring.

94. Grinder pumps. Most grinder pump installations require either a 208- or 230-v single-phase power source. Some larger installations will use a three-phase service. In either case, the following recommendations can be made concerning the electrical installation.

95. Since the single-phase submersible grinder pumps have a capacitor-start type motor, the capacitors and starter relays must be located in a separate control panel enclosure. The control panel can be located either outside using a NEMA 3 enclosure or inside the service location using a NEMA 1 enclosure. For safety reasons, it is usually recommended that the control panel be placed within sight of the pump wetwell or septic tank.

96. At a minimum, the control panel should include a magnetic starter

with ambient compensated bimetallic overload relay. The relay should have a test button for simulation of overload trip and a manual reset button. Fault protection should be provided via a molded case magnetic circuit breaker and internal common trip or multiple poles. A hand-off-automatic toggle switch for hand operation with a green light to indicate the pump running mode should be provided for each grinder pump and mounted on a bracket inside the control panel enclosure. The control panel should be of high quality construction that meets all safety codes as well as national electrical codes. Pump controls and wiring must be accessible and comply with all code regulations to ensure the safety of the service user or operating personnel in the event of power failure, pump failure, or flooded wetwell. In extreme cases, as an alternative to the above installation, an explosion-proof combination motor control/junction box may be installed inside the wetwell or septic tank.

97. Semipositive displacement pumps having the starter and capacitor in the pump core require only a standard junction box hookup to the power source.

98. Septic tank effluent pumps. The control systems for septic tank effluent systems are somewhat less complicated than those for grinder pump systems. Since the motor starters and capacitors are located inside the motor housing, a separate control panel containing these components is not required. A separate control panel may be required, however, for the level control sensors and other components.

99. Wiring and alarm systems. Wiring to connect the pump motors to the power source must be of the correct size and suitable for direct burial. Wiring should comply with all applicable electrical codes. Wiring for the level sensors and control panel (if required) should also comply with applicable codes.

100. An audio and/or visual high water alarm should be provided in both types of pump installations. This alarm alerts service personnel to possible system malfunctions. The alarm should be designed such that it can be reset after a malfunction, but not be disabled for future malfunctions. The alarm system can be mounted inside or outside the service installation. It also may be desirable to install one alarm inside the service location with a backup alarm located at the pump installation.

valves should be installed in accessible locations with adequate clearance for operation and maintenance. Air and ground are not to be used for valve float action. The design of such devices must provide float and valve from reaching the valve operating mechanism. Provision should be made for cleaning the valve by backflushing. Manually operated valves can also be installed. To ensure successful performance, these valves must be opened at frequent intervals by operating personnel.

#### Cleanouts

132. Cleanouts should be provided at strategic locations throughout the system. The actual location of cleanouts is a function of the system layout. Single dead-end layout requires only one terminal cleanout while a multiple cluster feeder design would require a terminal cleanout for each cluster.

Cleanouts and/or shutoff valves should be provided at all pipe junctions and at locations where pipe sizes change. Line cleanouts for small-diameter force mains may be constructed using meter boxes as illustrated in Figure 21. Where more space is required for cleaning equipment, cleanouts may be constructed in manholes or vaults. If it is considered necessary to isolate a section of the pressure sewer main, a valve may be installed ahead of the wye (Figures 18-20). When the cleanout is placed in a vault or manhole, a sump should be constructed in the floor. Ground water, condensate, or wastewater that accumulates in the structure can be more readily removed with a portable sump pump.

#### Terminal manholes

133. The pressure sewer main will terminate at a treatment facility, lift station, or gravity sewer system. Pressure sewers should be designed to backflow at all times. A typical terminal manhole for a pressure sewer system discharging to a gravity sewer system is illustrated in Figure 22. This arrangement is designed to minimize turbulence. Note that the end of the pressure sewer should have a removable plug to facilitate cleaning.

#### Service connections

134. A wye or tee structure for maintaining connections from the service lines to the main sewer main are to wet tap the service line as the service connection is being made to provide a plugged connecting wye or tee on the main sewer main at the time of construction. If wyes or tees are provided on the main sewer main during construction, the location of the connection should be marked with a flag or otherwise excavation to locate connection points. The location of the wye or tee on the service line and pressure sewer main

## Valves

127. All valves should be full diameter opening to permit cleaning of the pressure sewer with a polypig or other devices which are pushed or pulled through the system. The materials of construction of valves should be compatible with the materials used in construction of the pressure sewer system. Valves in nonmetallic pipelines should be iron, bronze, PVC, nylon, or other approved material. Valves should have either flanged or screwed ends. Valves in metal pressure sewer systems should be iron body, bronze mounted with flanged or mechanical joint ends. In smaller sizes, valves may be all bronze with screwed ends.

128. Valves should be hydrostatically tested in the shop at 250 psi. Pressure should first be applied while the valve is in the open position and then with the valve in the closed position. Valves should remain tight and secure under the test pressure. Valves failing the test should be rejected for pressure sewer service.

129. Valve station location of valves will be a function of the system design and layout. In order to permit segment isolation may be necessary for maintenance purposes. The longer the distance between valve stations, the more difficult it is to make the necessary isolations. The use of an arbitrary limit for maximum valve spacing, however, is unnecessarily restrictive. For example, a 4- to 5-mile spacing in a relatively sparsely populated area may be appropriate for construction, while in more densely developed areas, the spacing may have to be in 100-foot increments. Spacing not to exceed 600 ft is recommended for transmission lines, while spacings in low-density areas should be 100 to 200 ft. In addition to most relatively simple valve box designs, valves should be equipped with the necessary gate elements and valves, should be equipped with the necessary gate elements and valves, should be equipped with the necessary gate elements and valves.

## Pressure Relief Valves

130. Pressure relief valves in the pressure sewer system should be installed at the highest elevation in the system. Tripped pressure rises should be avoided. Pressure relief valves should be installed at high points in the system. Pressure relief valves should be installed at the buildup of air or gases from the system. Pressure relief valves should be fabricated from materials compatible with the materials of construction of the pressure sewer system.

131. Pressure relief valves may be either manually or automatically

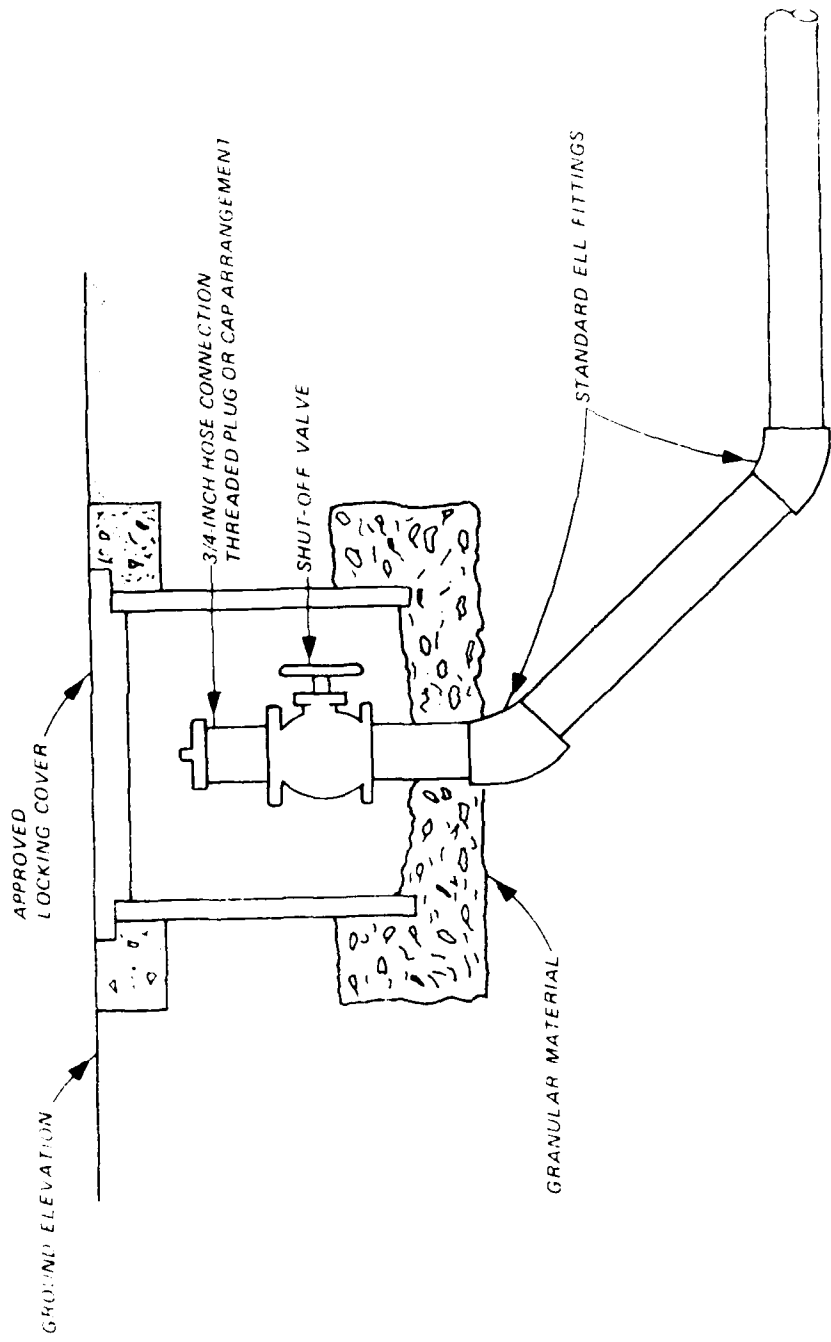

Figure 41. Cleanout arrangement at end of pressure sewer main.

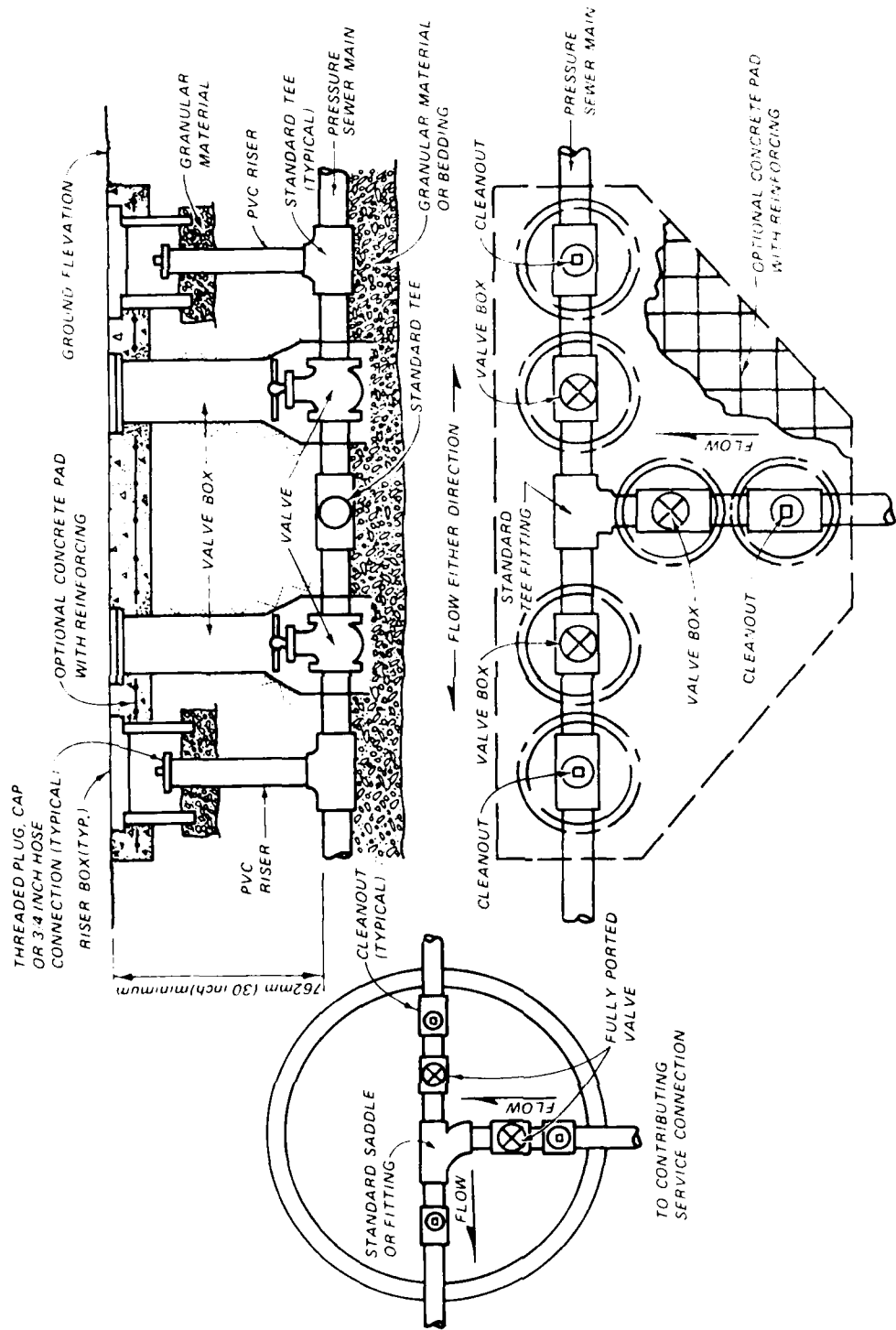

Figure 20. Valve box and cleanout arrangement at intersection of pressure sewer main.

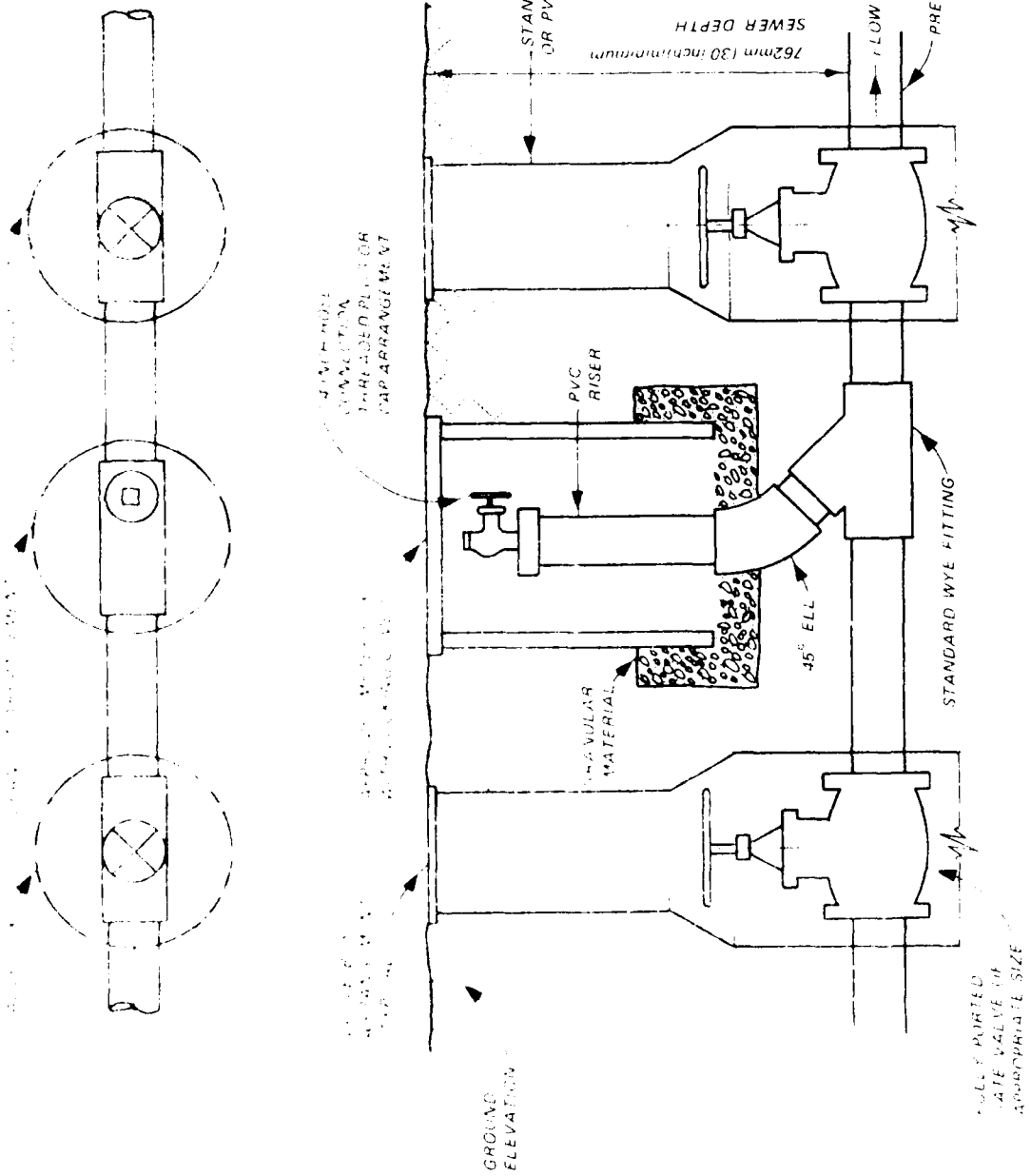
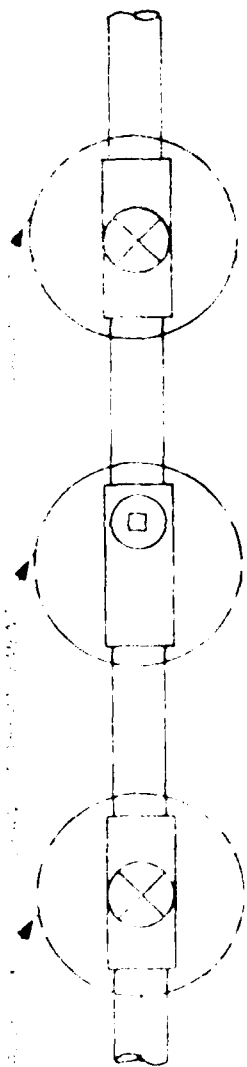

Figure 19. Riser box and cleanout arrangement with hose connection



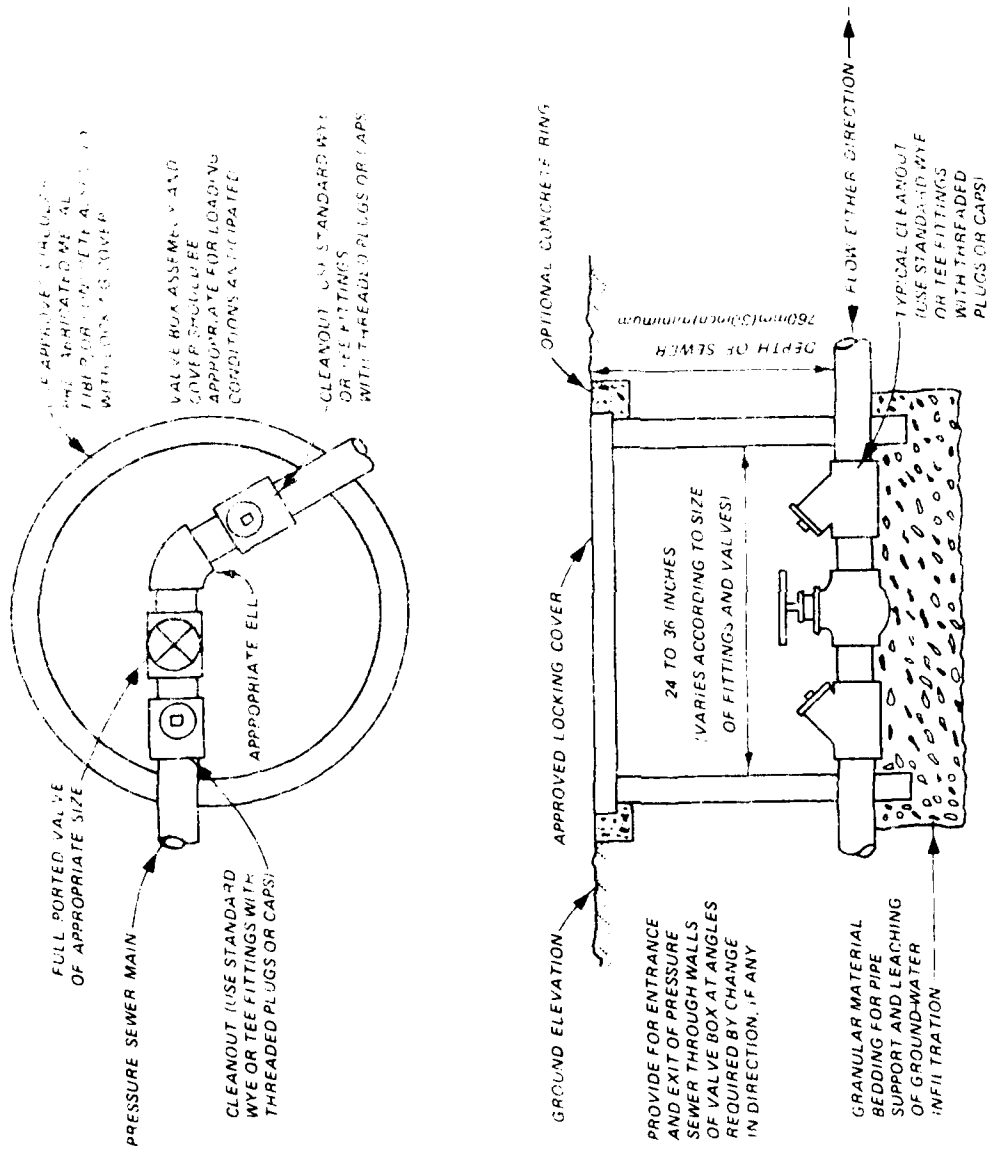

Figure 18. Valve box and cleanout arrangement along straight run and in changes of direction



pipe are common materials of construction for water distribution piping and wastewater force mains. Various linings such as cement mortar and coal tar epoxy are often used with DI or CI pipe to minimize corrosion problems. The relatively high cost of DI and CI pipe limits its application in pressure sewer installations. *DI and CI pipe may have application in those cases where severe structural loadings are expected to occur.*

124. DI pipe is available in sizes ranging from 3 in. to 54 in. and a variety of pressure classes. The pipe should be manufactured in accordance with American National Standards Institute (ANSI) A21.11 (AWWA C151). DI pipe may be specified to meet any diameter, class, lining, and type of joint. The design of the pipe should take into account the internal pressure or vertical deflection under the anticipated loading conditions. The design also must account for manufacturing tolerances and the installation procedures as specified in ANSI A21.11 (AWWA).

#### Special Notes

box and cover.

125. Boxes and covers for man release facilities, cleanouts, and other *appurtenances* should be so constructed to permit easy removal of the facilities for maintenance and to permit convenient operation of any operating mechanisms located in the box. The facilities should be installed such that operation can be accomplished from a convenient, accessible position. The word "SEWER" should be clearly marked on each of the box or cover covers. Figures B7-21 illustrate typical box and cover configurations for sewers and force sewer systems.

Valve box

126. Valve boxes should be constructed of vehicular traffic-rated plastic or casted cast iron. The boxes should be set in its position during backfilling operations to ensure that they will be in vertical alignment and parallel to the valve operation stem. The lower casing of the unit should be installed in such a manner as to be supported and fast to rest directly on the body of the valve or on the pressure sewer main. The upper casing of the unit should then be placed in proper alignment and adjusted to the final grade. Care should be taken during the backfilling process to ensure that the backfill is *uniformly compacted* around the unit and that the vertical alignment of the unit is not disturbed.

manufactured in accordance with the requirements of ASTM D2239, ASTM D3035, or AWWA C901. PE pipe has performance characteristics similar to PVC pipe. PE pipe joints are heat fused in accordance with the requirements of ASTM D3261.

118. Acrylonitrile-butadiene-styrene pipe. ABS pressure pipe is not normally used for pressure sewer system piping. However, ABS pressure rated pipe has been used in water distribution systems and could have application in the construction of pressure sewer systems. ABS has performance characteristics similar to PVC or PC pressure pipe. ABS pressure pipe should be manufactured in accordance with ASTM D2282. ABS pressure pipe can be jointed using either flexible elastomeric seals in accordance with ASTM D3139 and ASTM F477 or cement joints in accordance with ASTM F545 and ASTM D2235.

#### Other piping materials

119. Fiberglass reinforced thermosetting resin (FTR) pressure pipe. FTR pipe is used commonly in the chemical process industries for the transport of water and wastewaters with elevated temperatures (up to 125° F). The relatively high cost of FTR pipe has precluded its general use for pressure sewer service. However, FTR pipe would be an acceptable alternate pipe material for severe service. FTR pipe should be manufactured in accordance with ASTM D2996, D2310, or D3754 with dimensions as specified by ASTM D3567.

120. Pressure sewer pipe is normally specified by either the pressure rating or the required resistance to the anticipated hydrostatic stress as determined in accordance with ASTM D1598, D1599, or D2837. The anticipated pressures in the system must be quantified for both magnitude and frequency. In the cases where this is not possible, it is common practice to specify pipe rated at twice the normal anticipated operating pressure.

121. The sustained pressure capacity of pressure PVC pipe is a function of its operating temperature and the length of time that the sustained pressure acts upon the pipe. Tables and charts are available from PVC pipe manufacturers to determine the allowable sustained pressure for the design water temperatures and length of pressure (Uni-Bell Plastic Pipe Association 1982).

122. For temperatures higher than the 74° F standard rating temperature, the pressure-sustaining capacity of the PVC pressure pipe decreases significantly. The reduction in pressure rating must be considered during the design process in those cases where there is any possibility of encountering elevated wastewater temperatures.

123. Ductile iron pressure pipe. Ductile iron (DI) and cast iron (CI)

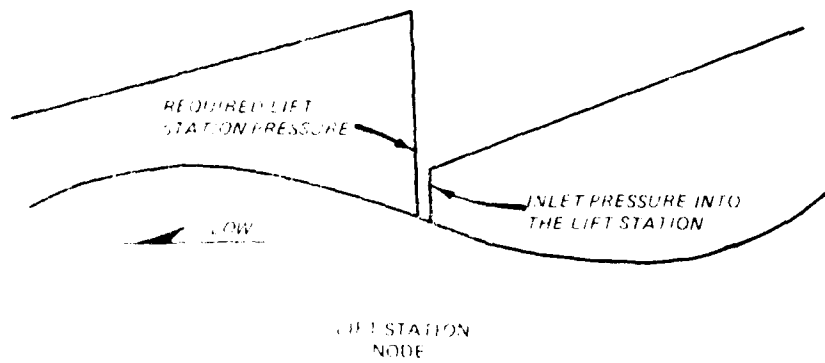
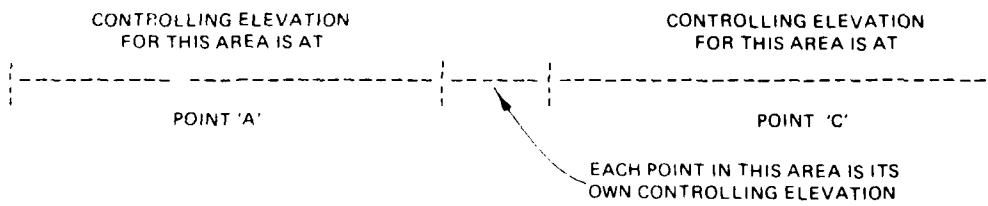
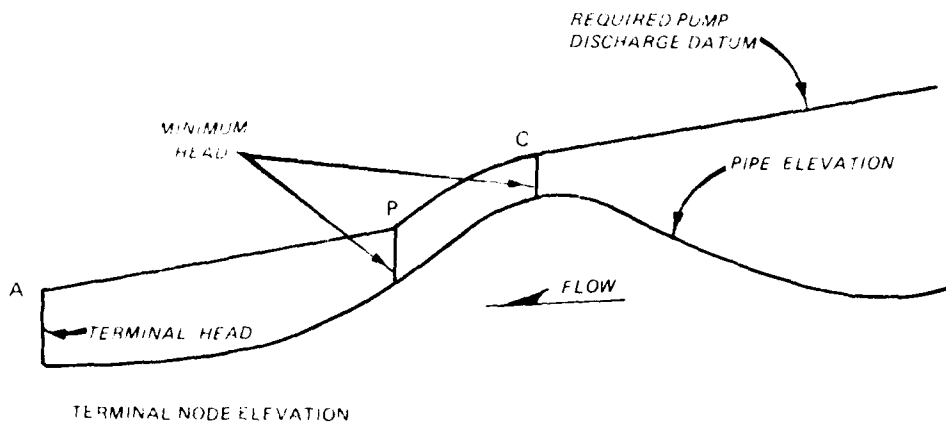

Figure 17. Schematic representation of pump head calculation

terminal node, a lift station, or a controlling elevation is accumulated and the required pump head at each node may be determined. Figure 17 illustrates the calculation of the required pump heads. The required pump head is the difference between the required pump discharge datum and the pipe elevation. If the required pump pressure becomes excessive, the user may wish to install intermediate lift stations at selected points in the system.

### Materials of Construction

#### Thermoplastic materials

114. Polyvinyl chloride. Pressure sewer mains have generally been constructed of PVC. PVC pressure sewer pipe should be manufactured in accordance with the requirements of ASTM Specifications D1785, D2241, or D2672. American Water Works Association (AWWA) Standard C900 is also suitable for use in pressure sewer construction; however, it is usually more expensive than the ASTM pipe because it is designed to a higher standard. The ASTM designations are applicable to pressure pipe having nominal diameters between 1/8 and 12 in. The AWWA C900 designation is applicable for pressure pipe having nominal diameters between 4 and 12 in.

115. PVC pipe can withstand short-term pressure surges significantly higher than the long-term pressure rating of the pipe without damage. For example, Class 150 PVC pipe conforming to AWWA C900 can withstand an internal pressure of 755 psi for about 1 min but will fail if the same pressure is applied for about 5 min. The same pipe will, however, normally withstand an internal working pressure of 150 psi throughout the design period without failure. The design of PVC pressure pipe must be based on the long-term working pressure of the pipe. PVC pressure pipe may have flexible bell joints using elastomeric seals or may be solvent welded. Joints should conform to the requirements of ASTM F477, ASTM D1139, ASTM F543, or ASTM D2564.

116. Various fittings have been developed for PVC pipe. The fittings must be compatible with the pressure pipe and also must be designed to withstand the normal operating pressure as well as anticipated surge pressures without failure. Steel or iron pipe fittings may also be utilized if the appropriate ASPI or AWWA specifications are met. Internal and external corrosion protection must be considered when ferrous metal fittings are used.

117. Polyethylene pipe. Polyethylene pressure pipe should be

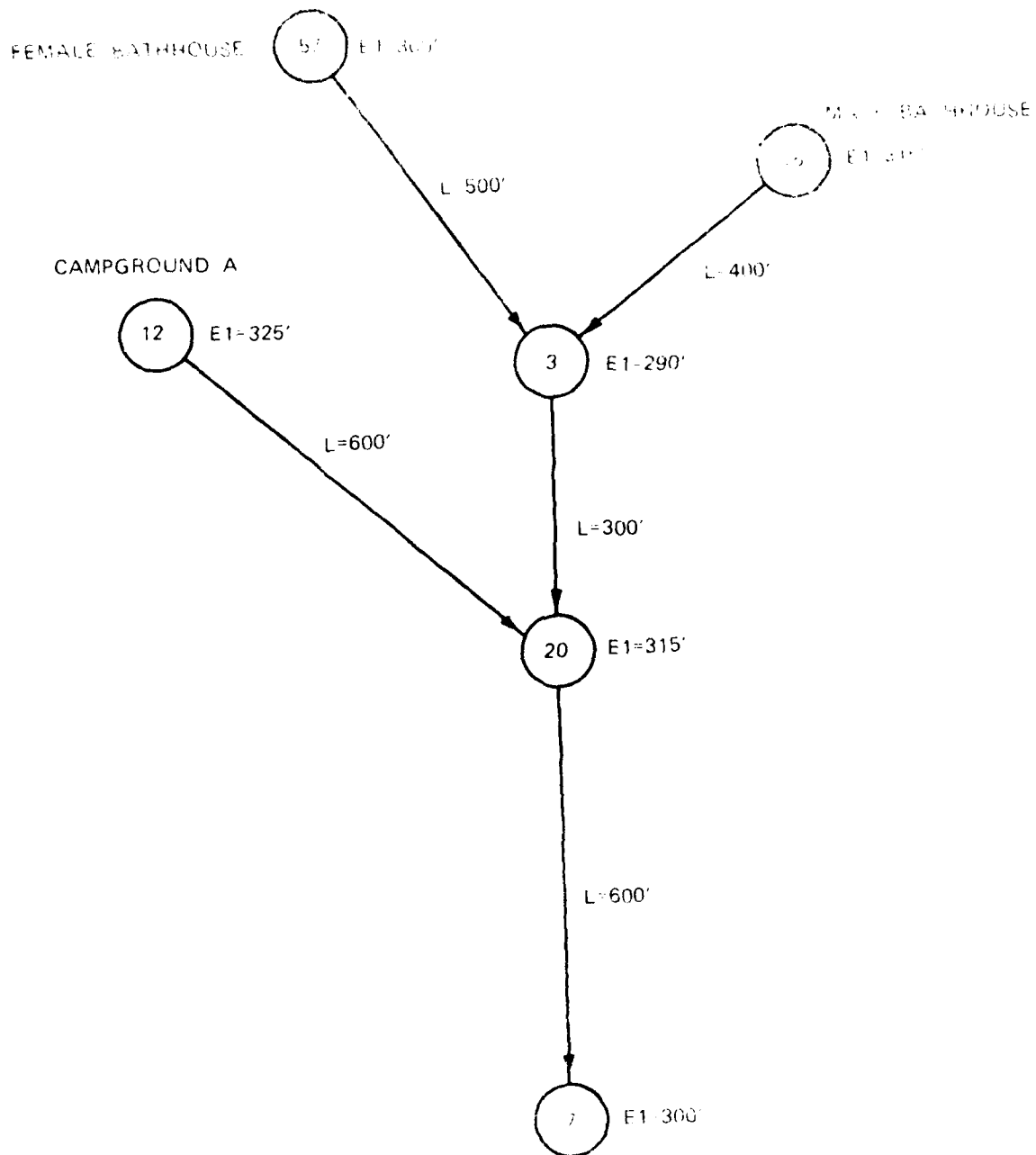

Figure 10. Total cost of compressed air compressor power system

iterations to determine system characteristics under several operating conditions to simulate the time-varying nature of the system; i.e., the system should be analyzed with various combinations of pumps in simultaneous operation.

109. In addition to traditional hydraulic design concerns, an analysis of water hammer and surge conditions may sometimes be necessary. Water hammer and surge analysis normally will not be a major concern in the recreation area design because of the small size of the system and the relatively low heads and flows. For large systems or systems operating at relatively high heads (greater than 100 ft), the system should be analyzed for potential water hammer and surge problems.

110. Computer programs are available for the design of pressure sewer systems (H. E. Myers Company 1984, Systec 1982). These programs are usually node-oriented. Figure 16 is typical of a simplified system nodal schematic. The solution of the network is usually accomplished in two passes. The first pass of the system is conducted in the direction of flow. Flows, if they occur, are accumulated at each node along the network. The magnitude of the flows entering at each node is usually input by the user; however, in some programs formulated for the design of residential installations, the user inputs the number of houses served by the node and flows are calculated within the program.

111. The first path through the system is designed to accumulate flows and assign initial values for pipe sizes. Two options are generally available for selecting pipe sizes. In the first option the user preassigns the sizes of pipe between each node. In the second option, the program will select pipe sizes based on the maintenance of a minimum specified velocity for the flows accumulated in the upstream node of that pipe segment. Typically, the programs will select the minimum commercially available pipe size that will produce a velocity at design flow between 2 and 3 fps.

112. Once the pipe size has been selected, the head loss in each pipe segment is calculated for design flows. In addition, it is customary to calculate wastewater residence time in the pipe at design flows. The residence time can be used to estimate the wastewater characteristics at the treatment plant.

113. After completion of the first pass through the system, a second pass is made in the direction opposite the flow. The head loss from the

Barnes, Inc. (1977), recommends using a C-factor of 150 for septic tank-effluent pumping systems. For grinder pump systems a C-factor of 140 provides a safety factor for anticipated grease and solid buildup problems.

106. Although the hydraulic design of a pressure sewer system must take into account several factors, the primary concern is the head discharge characteristics of the selected pressurization units. The simplest and most common installation employs use of centrifugal pumping units that exhibit the general capacity-head curves illustrated in Figure 15. In addition to matching capacity-head requirements of the individual pressurization units, it is also recommended that a centrifugal pump should not be specified under conditions requiring greater than 85 percent of the available head when operating alone.

107. The following procedure is typically used to approximate the initial hydraulic design of a low pressure sewer system.

- a. Determine the ultimate number of facilities to be served by the system and choose a design peak flow value for each facility.
- b. Prepare a condensed plan and profile of the system including appropriate nodes for changes in direction, changes in pipe size, and points of entry for wastewater flows.
- c. Evaluate the requirement for air release and pressure-sustaining valves.
- d. Determine and plot hydraulic grade lines (HGL) corresponding to various pipe sizes. Pipe sizes that indicate an excessive total dynamic head (TDH) should be eliminated from further consideration. Appropriate adjustments must be made where pressure-sustaining valves are used to maintain positive pressure and prevent line drainage.
- e. Select initial pressure main configurations and sizes based on economics, pressure limitations, and a reasonable approximation of pump characteristics.
- f. Prepare a dynamic HGL based on the configuration and pipe sizes selected in step e above and select individual pressurization units based on site-specific head conditions and required flow capacities. Individual pressurization unit characteristics, derived from manufacturer's literature, must be tested for sufficiency by comparing the pump curves with the system HGL where the pump lateral intersects the pressure sewer main. The pump capacity-head curves must be adjusted for head losses in the service line.

108. The selection of an appropriate pressurization unit depends on the hydraulic profile of the system and the characteristic (capacity-head) curves of the pump chosen for the system. The analysis should include several

## PART V: PRESSURE SEWER MAIN CONSTRUCTION

### Hydraulic Design

101. Pressure sewer systems are generally designed as a branched system. Looped systems similar to water distribution systems are technically feasible; however, branched systems are considered to have both operational and maintenance advantages. If problems develop in one of the branches, the branch can be isolated for repair without affecting the remainder of the system. The branches and mains should be laid out to provide the shortest run and the fewest changes of direction. Interconnecting piping between branches may be installed to provide some degree of system redundancy; however, the opportunity to economically install these looping interconnections does not occur very often. In any case, valves in appropriate places ensure that the system is operated in the branched mode and as such must be analyzed as a branched system.

102. The hydraulic design of pressure sewer systems is normally based on a compromise between maintenance of scouring velocities and minimization of head losses in the system. Maintenance of scouring velocities is particularly important for grinder pump systems where grease and solids may present problems in system operation.

103. Minimum scouring velocities can be estimated by the following equation (Kriessel, Cooper, and Reyek 1977):

$$V_s = \frac{\sqrt{D}}{2} \quad (2)$$

where

$V_s$  = minimum scouring velocity, fps

$D$  = inside diameter of pipe, in.

104. Experience in the operation of several pressure sewer systems indicates that an absolute minimum velocity of 2 fps should be maintained if at all possible.

105. Head loss calculations for pressure sewer systems are generally based on the Hazin-Williams formula. For PVC or other relatively smooth pipe materials, a Hazin-Williams C factor of 140 to 150 is normally used. Peabody



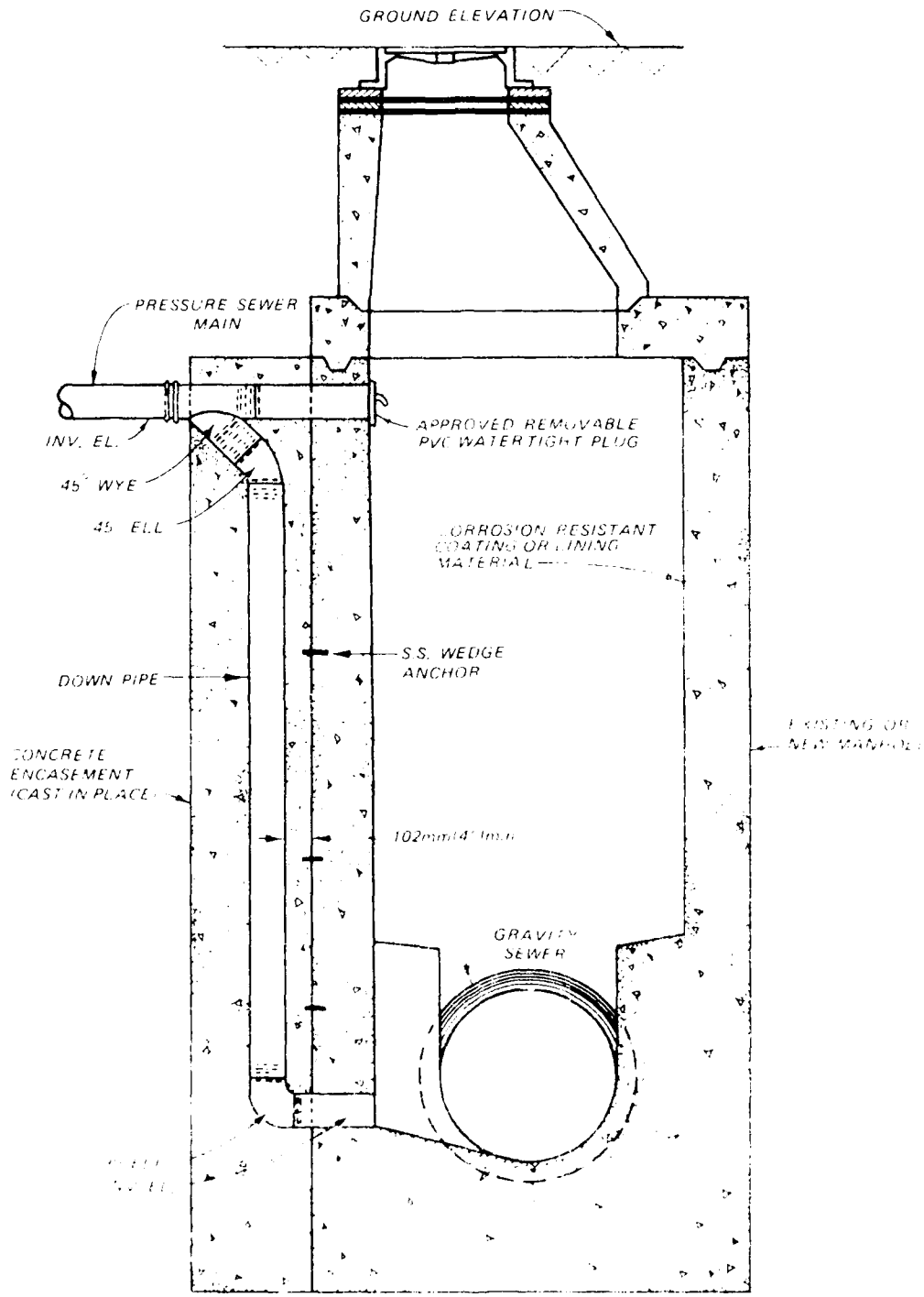

FIGURE 22. DETAIL FOR PRESSURE MAIN CONNECTION

are constructed using PVC or PE materials, this section is restricted to a discussion of compatible materials. However, similar connections could be made were other nonplastic materials and compatible fittings utilized.

135. Wye and tee saddles are available to install 1-1/4 to 2-in. ID service lines to the pressure sewer main. The pressure sewer main in the street or right-of-way location can vary between 1/2 and 12 in. ID.

136. A popular method of connection of PVC service lines to PVC pressure sewer main is by wet tapping and installation of a tee connection. Solvent weld service connections of this type are available in 1/2- to 2-in. diameters. Typical service connections are illustrated in Figure 23.

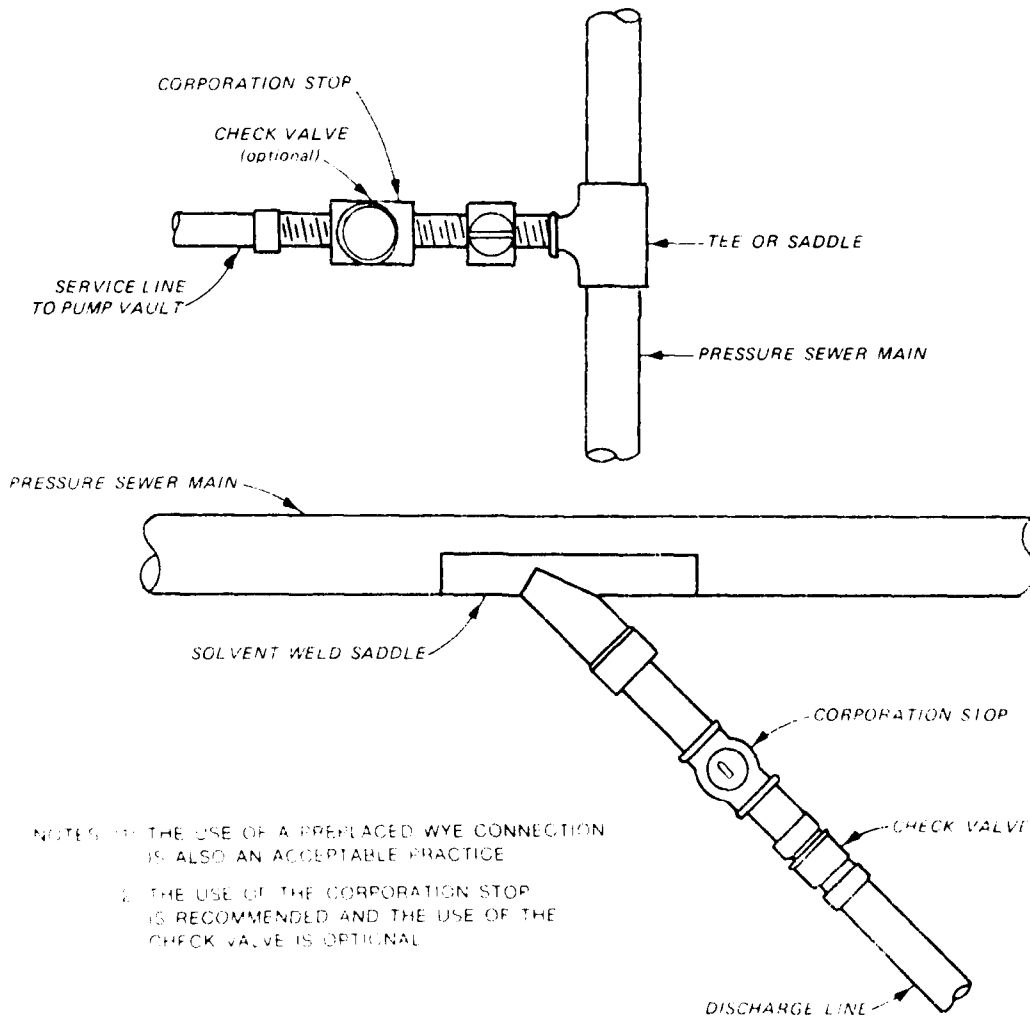

Figure 23. Typical service connections to pressure sewer mains

137. Polyethylene pipe cannot be solvent welded but must be heat fused to provide installation of connecting service lines. Polyethylene can form a solid joint at high temperatures so that the joint itself is stronger than the pipe wall. A variety of transition fittings for polyethylene pipe are available.

### Installation and Testing

#### Pipe installation

138. Pipe laying. Pressure sewer main installation should be in accordance with AWWA C600 for ferrous pressure pipe, ASTM D2774 for thermoplastic pressure sewer pipe, and ASTM D3839 for thermosetting pressure sewer pipe. As an alternative, approved manufacturers' written installation instructions can be used.

139. Fittings and connections used where grade alignment changes require offsets greater than those recommended by the pressure sewer pipe manufacturer should be certified by the fitting or connection manufacturer for compatibility with the pressure sewer pipe. Prior to installation, all pipe and fittings should be cleaned and inspected for defects. All imperfections on the face of the spigot, tongue end, or shoulder should be cut away or repaired. Cracked, broken, or defective pipe or ancillary items should be rejected and removed from the job site.

140. During installation, all open pressure sewer main pipelines should be sealed with appropriate plugs when actual construction is not in progress. As installation progresses, the interior of the pressure sewer main should be kept free of dirt and debris.

141. Pressure sewer main installation should be approved only in dry trenches having a stable bottom. Where ground water is encountered, every effort should be made to secure a trench bottom free of water.

142. Pipe jointing. The requirement for pipe jointing for pressure sewer main installation shall be in accordance with AWWA C600 for ferrous pressure pipe, ASTM D2774 for thermoplastic pressure sewer pipe, and ASTM D3839 for thermosetting pressure sewer pipe. As an alternative, approved manufacturers' written jointing instructions can be followed.

143. Plugs, anchorage, and thrust restraints. Plugs for pressure sewer pipe wyes or tees, stubs, and valves which are not to be used immediately

should be made of an approved material and should be secured in place with a joint comparable to the pressure sewer main joint.

144. Anchors on pressure sewer mains should be placed at bends greater than 22.5 deg and changes in pipe size. Anchors should also be provided for appurtenances such as tees, stops, and valves. The anchors should consist of thrust blocks, restrained joints, or tie-rods depending on the piping material used and the trench conditions.

145. Thrust blocks should be concrete placed on and against undisturbed soil. The thrust blocks must be constructed such that the thrust forces are transmitted to the undisturbed soil. The concrete should have a minimum 28-day compressive strength of 2000 psi.

146. Restrained push-on joints, mechanical joints utilizing set screw retainer glands, or metal harnesses of tie-rods or clamps may be used instead of concrete thrust blocking. Tie-rods, clamps, or other components of dissimilar metal should be protected against corrosion by hand application of a bituminous coating or by encasement of the entire assembly with 8-mil-thick, loose polyethylene film applied in accordance with AWWA C105.

147. Pipe marking. The pressure sewer main should be color coded or clearly marked to indicate the function of the piping system. Nonmetallic pressure sewer system piping should be traced with underground magnetic marking tape. The marking tape should be installed directly over the pipeline 4 to 6 in. below the ground surface or pavement. Marking tape should be made of inert polyethylene material with a minimum thickness of 4 mils. The marking tape should be color coded "safety green" as adopted by the American Public Works Association. The tape should bear printed identification describing the type of pipeline being marked. The imprint should continuously repeat itself for the entire length of the tape. The marking tape should have a 1-mil-thick reflective foil core.

148. Where ductile iron is installed, a 6-mil sheet of inert green polyethylene marking a width of twice the pipe diameter should be laid directly on top of the pipe before the trench is backfilled.

(p) Backfilling

149. Flushing. Prior to the commencement of pressure and leakage tests, the sections of pipe to be tested should first be polyrigged or flushed to remove any debris that may remain in the pressure sewer main. The flushing procedure should develop a water velocity in the pressure sewer main sections of

at least 2.5 fps and should result in at least a 100-percent turnover of the water in the pressure sewer main.

150. Pressure test. After the pressure sewer main has been installed, partly backfilled, and fully charged with water, it should be subjected to a hydrostatic pressure equal to either 150 percent of the maximum operating pressure or the maximum pressure obtainable during the cleaning operation, whichever is greater, but not to exceed the pressure rating of the type of pressure pipe specified. The duration of this pressure test should be for a period of not less than 1 hr. The basic provisions of AWWA C600 and C603 should be applied.

151. Leakage test. After completion of the pressure test, a leakage test should be conducted to determine the quantity of water lost by leakage under the specified test pressure. The test pressure is defined as the maximum operating pressure of the pressure sewer main. Applicable provisions of AWWA C600 and C603 will apply. Duration of each leakage test should be a minimum of 1 hr for the pressure test period.

152. Leakage is defined as the quantity of water to be supplied in the newly constructed pressure sewer or valved section under test, which is necessary to maintain the specified leakage test pressure after the pressure sewer main has been filled with water and the air expelled. The allowable leakage in gallons per hour for pressure sewer mains should not be greater than that determined by the formula (Florida Department of Environmental Regulation 1981):

$$L = \frac{ND\sqrt{P}}{7,400} \quad (3)$$

where:

L = allowable leakage, gal/hr

N = number of pipe joints in length of pressure sewer main tested

D = nominal diameter of the pressure sewer main pipe, in.

P = average test gauge pressure during leakage test, psi

Allowable leakage rates at various pressures are shown in Table 12 based upon nominal pressure pipe sections having a length of 20 ft.

#### Special Construction

153. The installation of pressure sewer mains may require consideration

of special construction materials if the proposed sewer is to be installed over existing transportation facilities. The appropriate design and construction provisions may apply to the following: under-crossings, roadway crossings, bridge crossings, potable water supply crossings, and installation in the vicinity of a potable water supply well.

#### Roadway crossings

154. All required permits and construction requirements should be obtained from the roadway owner prior to construction. In those cases where all roadways will be crossed, appropriate internal coordination should be accomplished.

#### Railroad crossings

155. The railroad owner has jurisdiction over all railroad tracks that may be crossed by pressure sewer mains. All required permits and construction requirements should be obtained from the railroad owner prior to construction. The railroad owner must approve and authorize the under-crossing and must be notified in advance of any construction within the railroad right-of-way. Formal permitting procedures are normally implemented by each railroad owner. The method of installing casing and carrier pipes under the railroad tracks, either by open trench excavation, jacking, or boring, must receive the written approval of the railroad owner.

#### Bridge crossings

156. Bridge crossings design and construction must conform to all regulations of the agency having jurisdiction over the work regarding the methods of construction and the protection of the site of the bridge crossing during the construction period. Pressure pipe and fittings installed at bridge crossings must meet the requirements for ductile iron pressure pipe. All bolts, pipe hangers, nuts, studs and bolt anchors for pipe hangers, clamps, and supports should be series 300 stainless steel or shop coated for corrosion protection. Pipe suspension systems must receive written approval prior to construction of the pressure pipe materials and pipe hanger spacing.

157. The word "WASTEWATER," in easily discernible letters, should be stenciled or otherwise printed with fade resistant paint at each end and at each midpoint between pipe hangers after installation.

#### Potable water supply crossings

158. Under normal conditions, pressure sewers crossing under potable water supply mains shall be constructed to provide a separation of at least

18 in. between the bottom of the water main and the top of the pressure sewer.

159. When location conditions are such that pressure sewer mains crossing under water mains will have less than 18 in. of vertical separation, the pressure sewer main shall be concrete encased or installed within a carrier pipe for a distance of about 10 ft measured perpendicularly on either side of the potable water supply main.

160. When pressure sewer mains cross over potable water supply mains, additional protection of the potable water supply shall be achieved by either providing adequate structural support for the pressure sewer main to prevent excessive deflection of joints and settlement, or centering the pressure sewer main pipe at the crossing such that the joints will provide about 10 ft of clear distance from the potable water supply main.

161. Under normal conditions, all pressure sewer mains should be located with at least a 10-ft horizontal clearance from potable water supply mains or should be provided with an approved method of installation.

Installation in vicinity  
of potable water supply well

162. While no general statement can be made to cover all conditions, it is generally recognized that sewers should meet the requirements of the appropriate reviewing agencies (or in the case of CE recreation, reviewing agencies in the area) with respect to minimum distances from public water supply wells. Typical separation values range from 50 to 300 ft. For example, the state of Florida (Florida Department of Environmental Regulation 1981) requires that any public water supply well "shall be located a minimum of 100 feet from any potential source of contamination unless otherwise justified by natural or alternate treatment barriers." Babbitt, Doland, and Cleasley (1962) recommend a minimum separation of 50 ft, but state that 300 ft is preferred.

5.1.1.1

The cost of a sewer system is related with the construction of pressure sewer systems can be evaluated by considering the costs associated with the possible component parts of the system. The total capital cost of a specific system can be calculated as the sum of the costs of the individual components. The major components of a pressure sewer system may include: gravity piping and appurtenances, pressure sewer mains, conventional pumping stations, grinder pump stations, effluent pumps, and septic tanks. The costs presented in the following discussion are based on April 1984 manufacturers' and contractors' information. It should also be noted that most costs are based on residential applications since low pressure sewers have not been widely applied in recreation areas.

Gravity piping and appurtenances

164. The cost of gravity piping is primarily a function of pipe material, diameter, and depth of burial. The following tabulation presents typical unit costs for 8-in. vitrified clay, ABS truss pipe, and PVC sewer pipe for depths of burial up to 12 ft based on recent bid prices updated to April 1984 by using the Environmental Protection Agency Sewer Construction Index.

Depth ft	Vitrified clay \$/lin ft	ABS Truss Pipe \$/lin ft	PVC Sewer Pipe (SDR-26) \$/lin ft
0-6	11.10-19.20	11.59-21.00	13.00-16.00
6-8	12.00-20.34	14.00-22.50	15.00-19.00
8-10	13.00-30.00	15.00-27.00	18.00-22.00
10-12	25.00-38.00	25.00-35.00	22.00-26.00

The cost of gravity piping appurtenances consists primarily of manholes. The cost of other common appurtenances are included in the cost of the piping. The following tabulation presents typical costs quoted for construction of a 48-in.-diam manhole (April 1984).

Depth, ft	Estimated Cost Range, \$
0-6	870-1,000
6-8	1,000-1,350
8-10	1,200-1,400
10-12	1,385-1,600



### Pressure sewer mains

165. Pressure sewer main costs can be estimated as a function of pipe size and pipe material. Depth of burial is generally not a determining factor since pressure sewer mains can be buried at a minimal depth to provide protection from frost or concentrated loads. The estimated costs (April 1984) of pressure sewer mains of various materials buried at a depth of 4 ft are presented in the following tabulation.

<u>Diameter</u> <u>in.</u>	<u>DR 26</u> <u>\$/lin ft</u>	<u>C900 (DR 25)</u> <u>\$/lin ft</u>	<u>C900 (DR 18)</u> <u>\$/lin ft</u>
1 1/4	1.50-2.25	--	--
3	2.00-3.50	--	--
4	3.00-4.25	3.50-4.50	4.50-5.50
6	3.50-5.00	4.25-5.75	6.00-7.00
8	4.50-8.00	6.00-8.50	10.00-11.00
10	7.50-11.00	10.00-11.50	13.00-14.00

### Conventional pumping stations

166. Pumping station costs are primarily a function of station capacity and depth of the station. For those flows associated with recreation areas, pump stations are usually purchased as package units. For a typical recreation area (design flow 100 gpm, depth 15 ft) pump station costs are estimated to range from \$17,000 to \$25,000 for a station using submersible pumps and \$20,000 to \$30,000 for a station using self-priming pumps. Costs may be higher where depths of installations are excessive or unusual soil conditions exist. These prices are based on manufacturers' quotes received in April 1984.

### Grinder pump stations

167. Grinder pump stations are limited in both available capacities and head ranges. Furthermore, the cost of grinder pump installations may be quite variable depending on the project. Quantity and/or distribution discounts may be substantial. Optional accessories and appurtenances will also affect the cost of the installation. For general planning purposes, it is only possible to develop a range of possible costs based on the size of the pumps installed. An estimate of the installed cost for both simplex (one pump) and duplex (two pumps) grinder pump stations of various sizes is presented in the following tabulation.

Pump Size hp	Simplex Station, \$	Duplex Station, \$
2*	4,125-5,500	6,000-8,000
3	7,500-10,000	10,000-13,500
5	**	12,500-16,000
7-1/2†	**	12,500-16,000

\* Recommended for residential use only.

\*\* Usually furnished in duplex station only.

† Available in high head capacity.

### Effluent pumps

168. Effluent pumps for septic tank-effluent pumping systems have been primarily utilized in residential applications and are generally available in smaller sizes than grinder pumps. Typical sizes used in residential application range from 1/2 to 2 hp. The installed cost of the pumping system for a septic tank-effluent pumping system is estimated to range between \$1,500 and \$3,000, depending on the pump and appurtenances selected for installation.

### Septic tanks

169. If a septic tank-effluent pumping system is selected, a septic tank must be installed as an integral part of the system. The cost of the septic tank will depend primarily on the size of the system being installed, type of excavation, and materials of construction. The installed cost of a typical residential size septic tank (1,000 to 2,000 gal) is estimated to range between \$1,500 and \$2,500. Difficult excavation conditions could significantly affect system cost. The cost of larger septic tank should be estimated based on site-specific conditions.

### Operation and Maintenance

170. The operation and maintenance costs associated with pressure sewer systems are less well defined than system capital costs. The operating experience with pressure sewer systems is relatively short term, and long-term impacts of system aging are not yet established. Furthermore, most cost studies have been performed on pressure sewer systems installed in residential rather than industrial or, more specifically, recreational area applications. Varying estimates have been provided by numerous authors. These estimates have been synthesized and are summarized below.

### Gravity piping

171. The operation and maintenance cost of gravity sewer piping is estimated to range between \$100 and \$400 per mile per year. This estimate is based on municipal application in an urban and suburban environment. It is anticipated that the operation and maintenance costs in a recreation area environment would be in the low range.

### Pressure sewer mains and service connections

172. The operation and maintenance costs associated with pressure sewer mains and service connections are ill defined; however, it is reported (Kriessell, Cooper, and Reyek 1977) that they are likely to be less than the cost of operating and maintaining gravity collection systems. Estimates of pressure sewer main and service connection operation and maintenance costs range from \$100 to \$300 per mile per year. As in the case of gravity sewer systems, the cost of maintaining pressure sewer systems in recreation areas will probably be in the lower range.

### Conventional pumping stations

173. The operation and maintenance costs for conventional pumping stations have been defined in a number of studies (Weston Environmental Consultants/Designers 1977; Cullinane, Harris, and Sun 1981). Although a number of factors affect the cost of operation and maintenance, a range of costs can be developed for station sizes that will normally be found in recreation areas. Maintenance costs (labor and materials) are estimated to range between \$500 and \$1,500 per year. The cost of operation is primarily a function of the quantity pumped, pumping head, and power cost. Annual power cost can be estimated using the following expression:

$$APC = \left( \frac{1536 \times Q_{ave} \times TDH}{e} \right) \times PC \quad (4)$$

where

APC = annual power cost, \$/year

$Q_{ave}$  = average flow, mgd

TDH = total dynamic head, ft

$e$  = wire to water efficiency, %/100

PC = cost per kilowatt hour, \$

### Grinder pumping stations

174. Grinder pump maintenance is estimated to range between \$200 and \$300 per year. However, these estimates are based on data collected from residential application, i.e., pumps less than 2 hp. Maintenance of larger grinder pumping stations associated with recreation area development will probably approach or slightly exceed that of conventional pumping stations. Service manpower requirements for grinder pump installations have been estimated to average 1 man-day per year (Kriessel, Cooper, and Reyek 1977). Again, it must be pointed out that these data were developed from residential installation using pumps less than 2 hp. Service manpower requirements in recreation areas will probably be slightly greater.

175. Operation costs consist primarily of power utilization, which is a function of pump size, pumping head, and quantity of wastewater pumped. Power requirements can be estimated using the formula presented above or using a "rule of thumb" of 1 watt per gallon pumped. It should be pointed out, however, that the rule of thumb was developed from residential applications and may not be strictly applicable to recreation area installations. Using the rule of thumb approach, the total power cost can be estimated by multiplying the volume of wastewater pumped, in gallons, times the cost per watt of electricity.

### Effluent pumping systems

176. The operation and maintenance costs associated with septic tank-effluent pumping systems have been estimated to be slightly less than grinder pump operation and maintenance (Kriessel, Cooper, and Reyek 1977). Estimates range between \$100 and \$200 per year for pump maintenance. Again, these estimates are based on residential applications. The savings in pump maintenance costs are offset by the costs associated with septic tank maintenance which include cleaning every 5 to 10 years at a cost ranging from \$100 to \$200 per cleaning. Service manpower has been estimated to range between 0.5 and 1.0 man-day per year per pump unit.

177. Power requirements can be estimated using the expression presented above for the flow rate of conventional pumping stations or by using a rule of thumb of 0.5 watt per gallon of wastewater pumped.

## PART VII: SUMMARY

178. Innovative and alternative wastewater collection and transport systems may provide a cost-effective alternative to waterborne transport of waste materials generated in recreation areas. Low pressure sewer system technology is well developed and has substantial potential for application at CE recreation areas. System design procedures have been developed for traditional residential community applications and require some modification for use in recreation areas. Both grinder pump and septic tank effluent pump systems may be suitable for recreation area use. For very small flow generating facilities, septic tank-effluent pumping systems may offer the advantage of reduced operation and maintenance cost over grinder pump systems. However, for general applications to recreation areas, the grinder pump system is probably the system of choice.

179. Although the design concepts have been substantially developed, each manufacturer offers equipment with somewhat different design criteria. This report attempts to synthesize suitable design criteria from a variety of sources. The information presented in this report can be used in conjunction with manufacturers' information to make appropriate design decisions.

180. The most important aspect of wastewater system design in recreation areas is the accurate projection of quantity and strength of wastewater that will require collection, transport, and treatment. Although the information developed in recent years has improved the accuracy of projection, the uncertainties associated with the projection of wastewater flows continue to be a major obstacle to the design of cost-effective systems.

181. The cost of low pressure sewer systems must be estimated on a project-specific basis. Cost estimates must be developed in close coordination with equipment vendors and manufacturers. Although capital costs are relatively well defined, operation and maintenance costs are lacking in both reliability and detail. This is particularly true for those systems using larger pump sizes. Extreme care must be exercised if accurate estimates of operation and maintenance costs are to be developed.

182. Generally, a traditional gravity sewer system is the least costly means of collecting and transporting wastewater. However, low pressure sewer systems offer a feasible alternative where topographic and geologic constraints preclude gravity collection systems. The criteria for design and

certification of low pressure sewer systems provided in this report serve as a  
guidance for the design of technically sound and cost-effective low pressure  
sewer systems for recreation areas.

## REFERENCES

- American Society of Civil Engineers. 1982. Gravity Sanitary Sewer Design and Construction, ASCE Manuals and Reports on Engineering Practice No. 60, New York, N.Y.
- Babbitt, H. E., Doland, J. J., and Cleasley, J. L. 1962. Water Supply Engineering, McGraw-Hill, New York.
- Cullinane, M. J., Jr. 1981. "Innovative/Alternative Wastewater Collection Systems for Corps of Engineers Recreation Areas," Miscellaneous Paper EL-81-7, US Army Engineer Waterways Experiment Station, Vicksburg, Miss.
- Cullinane, M. J., Harris, R. W., and Sun, P. T. 1981. "Process Design and Cost Estimating Algorithms for the Computer Assisted Procedure for Design and Evaluation of Wastewater Treatment Systems," US Environmental Protection Agency, Washington, DC.
- Ehlen, J. E., and Clark, L. K. 1978. "Pressure and Vacuum Sewer Demonstration Project - Bend, Oregon," EPA-600/2-78-166, US Environmental Protection Agency, Cincinnati, Ohio.
- E. H. Myers Company. 1984. "Myers Engineering & Design Manual," Ashland, Ohio.
- Florida Department of Environmental Regulation. 1981. "Design and Specifications for Low Pressure Sewer Systems," Tallahassee, Fla.
- Franklin, N. R., and Green, A. J. 1976. "Water Usage and Wastewater Characterization at a Corps of Engineer Recreation Area," Miscellaneous Paper Y-8-1, US Army Engineer Waterways Experiment Station, Vicksburg, Miss.
- Hahn-Matrix Pumps. 1978. "Pressure Sewer System Manual and Engineering Guide," Ashland, Ohio.
- Illinois Society of Professional Engineers. 1973. "Standard Specifications for Water and Sewer Main Construction in Illinois," Springfield, Ill.
- Kennedy, J., Cooper, T. A., and Keyek, J. W. 1977. "Alternatives for Small Wastewater Treatment Systems: Pressure Sewers/Vacuum Sewers," EPA 625/4-77-001, US Environmental Protection Agency, Cincinnati, Ohio.
- Ketchum and Eddy, Inc. 1979. Wastewater Engineering: Treatment Disposal, McGraw-Hill, New York.
- Ketchum and Eddy, Inc. 1981. Wastewater Engineering: Collection and Pumping of Wastewater, McGraw-Hill, New York.
- Reilly, M. S. 1968. "Analysis of Water Use at Toilet Shower Facilities in Two Recreation Areas at Great Ferry Lake," Tech. Report, US Army Engineer Waterways Experiment Station, Vicksburg, Miss.
- Reilly, M. S., and Carter, E. C. 1979. "A Study of the Collecting Recreation Areas and Toilet Shower Attendance at Ferry Lake Recreation Area," Technical Report, US Army Engineer Waterways Experiment Station, Vicksburg, Miss.
- Water Pollution Control Administration. 1975. "Performance of Wastewater Treatment Alternatives for Small Communities," Survey and Environmental Analysis, Washington, DC.

Office, Chief of Engineers. 1980. "Design of Small Systems Wastewater Treatment Facilities," Engineer Manual EM 1110-2-501, Part 2 of 3, Washington, DC.

. 1984. "Decentralized Wastewater Treatment," Engineer Circular EC 1110-2-531, Washington, DC.

Peabody Barnes, Inc. 1977. "Effluent Pressure Sewer Systems," Paper presented at the Water Pollution Control Federation Conference, Philadelphia, Peabody Barnes, Inc., Mansfield, Ohio.

Pennsylvania Bureau of Resources Programming. 1972. "Engineering Report, Sanitary Fixture Requirements for Pennsylvania Park Facilities," Philadelphia, Pa.

Systec, Inc. 1982. "Pressure Sewer Analysis," Mississippi State, Miss.

Uni-Bell Plastic Pipe Association. 1982. Handbook of PVC Pipe - Design and Construction, Dallas, Tex.

US Department of Interior. 1958. "National Park Building Constructor Handbook," Washington, DC.

Weibul, S. R., Straub, C. P., and Thoman, J. R. 1949. "Studies on Household Sewage Disposal Systems - Part I," US Public Health Service, Washington, DC.

Weston Environmental Consultants-Designers. 1977. "Wastewater Treatment Processes and Systems, Performance and Cost," West Chester, Pa.



Table 1  
Comparison of Grinder Pump and Septic Tank-Effluent  
Pump Pressurization Systems

<u>Item of Comparison</u>	<u>Grinder Pump</u>	<u>Septic Tank- Effluent Pump</u>
Onsite capital cost		
Pressurization unit	More	Less
Appurtenances	Less	More
Onsite operation and management (O&M)		
Pressurization unit	More	Less
Residuals handling	Less	More
Sewer main capital cost	Similar	Similar
Sewer main O&M		
$\frac{\text{Present Population}}{\text{Design Population}} \approx 1$	Similar	Similar
$\frac{\text{Present Population}}{\text{Design Population}} \ll 1$	More	Less
Treatment plant		
Capital cost	More	Less
O&M cost	More	Less
Corrosion and odor potential	Less	More

Table 2  
Typical Grinder Pump Wastewater Characteristics

Parameter	Average	Range
Biochemical oxygen demand (BOD <sub>5</sub> ), mg/l	350	216-504
Chemical oxygen demand (COD), mg/l	855	570-1,450
Total suspended solids (TSS), mg/l	350	138-468
Total Kjeldahl nitrogen (TKN), mg/l	80	41-144
Total phosphorus, mg/l	16	8-50
Grease, mg/l	81	31-141
pH (units)	--	7.1-8.7

Table 3  
Typical Septic Tank-Effluent Characteristics

Parameter	Average	Range
BOD <sub>5</sub> , mg/l	150	7-480
COD, mg/l	311	25-780
TSS, mg/l	95	10-695
Total nitrogen, mg/l	40	9-125

Table 4  
Recreation Area and Domestic Wastewater Characteristics\*

Parameter	(1)	(2)	(3)	(4)	(5)	(6)
Total organic carbon (TOC)	120	158	144	1,980	--	200
BOD	203	229	196	3,320	145	200
COD	430	439	336	6,370	388	500
BOD/TOC	1.69	1.45	1.36	1.68	--	1.00**
COD/TOC	3.58	2.78	2.33	3.22	--	2.50**
Total phosphorus	--	10.6	10.3	166	10	10
Orthophosphate	--	8.0	7.5	72	8	7
TKN	48.1	44.9	82.8	1,040	114	40
Ammonia (NH <sub>3</sub> )	39.4	40.5	82.4	1,000	64	25
Chlorine (Cl) <sup>†</sup>	--	84.4	91.9	1,070	--	50
pH (range)		(7.2-8.7)	(7.3-8.3)	(8.0-8.3)	--	

Note: (1) Denotes camping area without trailer waste dump; (2) denotes camping area with trailer waste dump; (3) denotes picnic area waste; (4) denotes trailer waste dump; (5) denotes average of three combination camping and picnic areas, Shelbyville, Ill.; and (6) denotes data from Metcalf and Eddy (1979).

\* All values except pH and ratios given in milligrams per litre.

\*\* Slightly lower than values given in other principal texts.

† Should be adjusted for Cl in supply water.

Table 5  
Estimate of Water Use by Fixture

Item	Rate gal/hr/fixture	Duration, hr		
		Camping	Picnic	Fishing
Water closet	36	8	10	--
Water fountain	10	4	8	--
Urinal	10	8	10	--
Laundry	50	4	--	--
Lavatory	15	8	10	--
Dump station	10	4	--	--
Shower	100	3	--	--
Fish cleaning station	50	--	--	4
Service sink	10	2	2	--

Table 6  
Fixture Unit Values (F. E. Meyers 1984)

Fixture Description	Fixture Unit Value
Bathroom group, consisting of lavatory, bath- tub or shower, and (direct flush) water closet	8
Bathroom group, consisting of lavatory, bathtub or shower, and (flush tank) water closet	6
Bathtub with 1-1/2-in. trap	2
Bathtub with 2-in. trap	3
Bidet with 1-1/2-in. trap	3
Dental unit or cuspidor	1
Drinking fountain	1/2
Dishwasher domestic type	2
Kitchen sink domestic	2
Kitchen sink domestic with waste grinder	3
Lavatory with 1-1/2-in. waste plug	1
Lavatory barber or beauty shop	2
Laundry tray two-compartment	2
Shower stall	2
Shower (group) per head	3
Sink (direct flush valve)	8
Sink (service type with floor drain)	3
Sink (scullery)	4
Sink (surgeons)	3
Urinal (with flush valve)	8
Urinal (with flush tank)	4
Water closet (flush valve)	8
Water closet (flush tank)	4
Swimming pools (per each 1,000-gal. capacity)	1
Unlisted fixture with 1-1/4-in. trap size	1
Unlisted fixture with 1-1/2-in. trap size	2
Unlisted fixture with 2-in. trap size	3
Unlisted fixture with 2-1/2-in. trap size	4
Unlisted fixture with 3-in. trap size	5
Unlisted fixture with 4-in. trap size	6
Water softener (domestic)	4

Table 7

Minimum Number of Plumbing Fixtures

Type of Facility	Water Closets				Type of Fixture				Lavatories			
	No. of Sites		No. of Fixtures		No. of Sites		No. of Fixtures		No. of Sites		No. of Fixtures	
	Male	Female	Male	Female	Male	Female	Male	Female	Male	Female	Male	Female
Commercial buildings	1-20	1	2	1-20	1	1-20	1	1-20	1	1	1	1
	21-30	2	3	21-30	2	21-30	2	21-30	2	2	2	2
Comfort stations for public areas	No. of Car Parking Spaces		No. of Fixtures		No. of Car Parking Spaces		No. of Fixtures		No. of Car Parking Spaces		No. of Fixtures	
	1-40	1	2	1-40	1	1-40	1	1-40	1	1	1	1
	41-80	2	4	41-80	2	41-80	2	41-80	2	2	2	2
	81-120	3	6	81-120	3	81-120	3	81-120	3	3	3	3

Note. A comfort station with good balance should contain two water closets, two lavatories, and one urinal for males, and three water closets and two lavatories for females. A sanitand substituted for one water closet is desired for females. A comfort station should provide facilities for 60 percent of users inside a 300-ft radius, 90 percent inside a 450-ft radius, and 100 percent inside a 600-ft radius except where conformance with local health codes might require a smaller radius. All fixtures are subject to possible malfunction and vandalism; therefore, stand-by fixtures should be provided even though user ratio would require only one fixture. Drinking fountains should not be installed in toilet rooms. Where urinals are provided for women, the same number should be provided as for men.

Table 8  
Camping Area Wastewater Production

Flow	Daily gal	Weekly gal	Wastewater Production	
			gost*	gpcd**
Minimum	71	5,222	34	9.7
Maximum	7,345	16,375	205	30.2
Range	7,274	11,153	171	20.5
Mean	1,406	9,947	105	18.8
Standard deviation	1,403	3,796	46	7.1

\* gost = gallons per occupied campsite per day.

\*\* gpcd = gallons per capita per day.

Table 9

## Design Criteria Information

Type of Area	Type Facility	Turnover Rate		No. of Persons per Unit			Range of Values Used			Water Quantities gpcd*			Sewage Quantities gpcd			
		Low	High	Median	Low	High	Median	Low	High	Median	Low	High	Median	Low	High	Median
Day use	Picnic--comfort station	1	1.5	1.5	3	6	4	3	10	5	2	8	4			
	overlook--comfort station	1	3	--	4	8	4	2	5	4	2	4	3			
	Boat launching ramp--comfort station	1	1	1	2	4	3	2	5	4	2	4	3			
Overnight	Camping (tent) water hydrant	--	--	--	--	--	5	--	--	25	--	--	19			
	Camping (trailer) water hydrant	--	--	1	4	5	5	15	50	30	--	--	25			
	Camping comfort station	1	1	1	4	5	--	25	25	25	--	--	20			
	Camping water hydrant plus washers	--	--	--	5	5	--	--	--	30	--	--	25			
	Camping water hydrant plus trailer	1	1	1	--	--	--	--	--	35	--	--	30			
	hookups	--	--	--	--	--	--	5	5	5	5	4	4	4		
Maintenance	Shops	--	--	--	--	--	--	--	--	2	--	--	1			
Visitor	information center	--	--	--	--	--	--	--	--	--	--	--	--			

\* gpcd = gallons per capita per day.



Table 10  
Average Wastewater Flows from Recreation Areas

Source	Unit	Typical Flow, gpud*
Apartment, resort bathhouses	Person	57
Bathhouses	Person	10
Cabin, resort	Person	42
Cafeteria	Customer	2
	Employee	10
Camps		
Camping, tent	Person	20
Camping, trailer	Person	25
Day camp (no meals)	Person	13
Resorts, limited plumbing	Person	50
Tourist, central bath and toilet facilities	Person	35
Cottages (seasonal occupancy)	Person	50
Cocktail lounge	Seat	20
Coffee shop	Customer	5
	Employee	10
Country club	Member present	104
	Employee	13
Dining hall	Meal served	8
Dormitory, bunkhouse	Person	39
Hotel, resort	Person	52
Laundromat	Wash	50
Store, resort	Customer	2.5
	Employee	10
Swimming pool	Customer	10
	Employee	10
Theater	Seat	2.5
Visitor center	Visitor	1
Parks		
Overnight, flush toilets	Person	20
Trailers, individual bath	Person	50
Picnic		
Bathhouse, showers, and flush toilets	Person	20
Toilet only	Person	4
Vault	Person	0.28

\* gpud = gallons per unit per day.

Table 11  
Miscellaneous Water Usage Estimates

Unit	Normal Water Consumption
water closet, tank	4-6 gal/use
water closet, flush valve, 25 psi	30 gal/min
wash basin	1-1/2 gal/use
bathtub	50 gal/use
flower head	25-30 gal/use
garden hose, 5/8 in., 25-ft head	200 gal/hr
garden hose, 3/4 in., 1/4-in. nozzle, 25-ft head	300 gal/hr
fire hose, 1-1/2 in., 1/2-in. nozzle, 70-ft head	2400 gal/hr
continuous flowing drinking fountain	75 gal/hr
lawn sprinkler	120 gal/hr
automatic home laundry machine	30-50 gal/load
dishwashing machine, home type	6 gal/load
dishwashing machine, commercial (does not include water to fill wash tank)	
Stationary rack type, at 15 psi	6-9 gal/min
Conveyor type, at 15 psi	4-6 gal/min
garbage grinder, home type	1-2 gal/day/ person

Table 12

Allowable Leakage per 1000 Ft of Pressure Sewer Main (gph)\*

Pipe Size in.	Test Pressure			
	60 psi	80 psi	100 psi	125 psi
2	0.10	0.12	0.14	0.15
3	0.16	0.18	0.20	0.23
4	0.21	0.24	0.27	0.30
6	0.31	0.36	0.41	0.45
8	0.42	0.48	0.54	0.60
10	0.52	0.60	0.68	0.76

\*For pipe with a nominal length other than 20 ft, the recommended allowable leakage may be obtained by multiplying the leakage calculated from Table 12 by the ratio of pipe lengths.

**END**

**FILMED**

8-85

**DTIC**