

AD-A156 507

METALLURGICAL CHARACTERIZATION OF THE INTERFACES AND
THE DAMPING MECHANIS. (U) MARTIN MARIETTA AEROSPACE
DENVER CO M S MISRA 12 JUN 85 MCR-85-605-ISSUE-1

1/1

UNCLASSIFIED

N00014-84-C-0413

F/G 11/4

NL



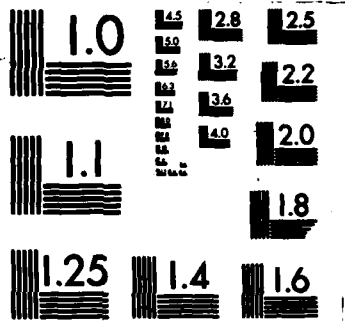

MICROCOPY RESOLUTION TEST CHART
NATIONAL BUREAU OF STANDARDS-1963-A

12

MCR-85-605
Issue 1

AD-A156 507

Progress Report No. 1

Metallurgical Characterization of the Interfaces
and the Damping Mechanisms in Metal Matrix Composites

Contract No. N00014-84-C-0413

Submitted to
Dr. Steve G. Fishman
Office of Naval Research

Mohan S. Misra
Program Manager

Martin Marietta
Denver, Colorado 80201

DTIC
ELECTE
S JUL 11 1985 D
E

DTIC FILE COPY

This document has been approved
for public release and sale; its
distribution is unlimited.

85 6 18 034

1.0 REPORTING PERIOD

This report summarizes the work performed from 2/4/84 to 6/12/85 on "Metallurgical Characterization of the Interfaces and the Damping Mechanisms in Metal Matrix Composites."

2.0 INTRODUCTION

Metal matrix composites are candidate structural materials for space applications. Large structures in space encounter natural and hostile disturbances, which introduce vibrations of a broad spectrum of frequencies (10^{-5} Hz to 10^5 Hz). These vibrations must be damped fast enough for effective maneuverability and dynamic dimensional precision. In the vibrational control designs of such structures, damping capacity of the structural material is a significant parameter. If metal matrix composites are to be used for space structures; their intrinsic damping behavior needs to be clearly understood and improved if necessary, through metallurgical modifications.

this report,
In the present investigation, a graphite-aluminum (Gr/Al) composite has been selected to study the microstructural features and mechanisms responsible for dissipating vibrational energy.

3.0 OBJECTIVES of this program were:

- (i) Development of a reliable test technique to accurately measure the damping capacity of metal matrix composites (MMC).
- (ii) Metallurgical characterization of the interface structures.
- (iii) Investigate the damping mechanism in metal matrix composites, and
- (iv) Recommend microstructural modifications to enhance damping in metal matrix composites.

4.0 TECHNICAL APPROACH

4.1 Specimen Design

A systematic approach to accomplish the objectives is to design fiber reinforced composite specimens with controlled interfaces, as outlined below:

Fiber Matrix Interface:

- (a) Pitch 55 Gr/6061 Al precursor wire (with perfect bond - Figure 1a).
- (b) Pitch 55 Gr/6061 Al precursor (imperfectly bonded - Figure 1b).
- (c) 6061 aluminum alloy wire.

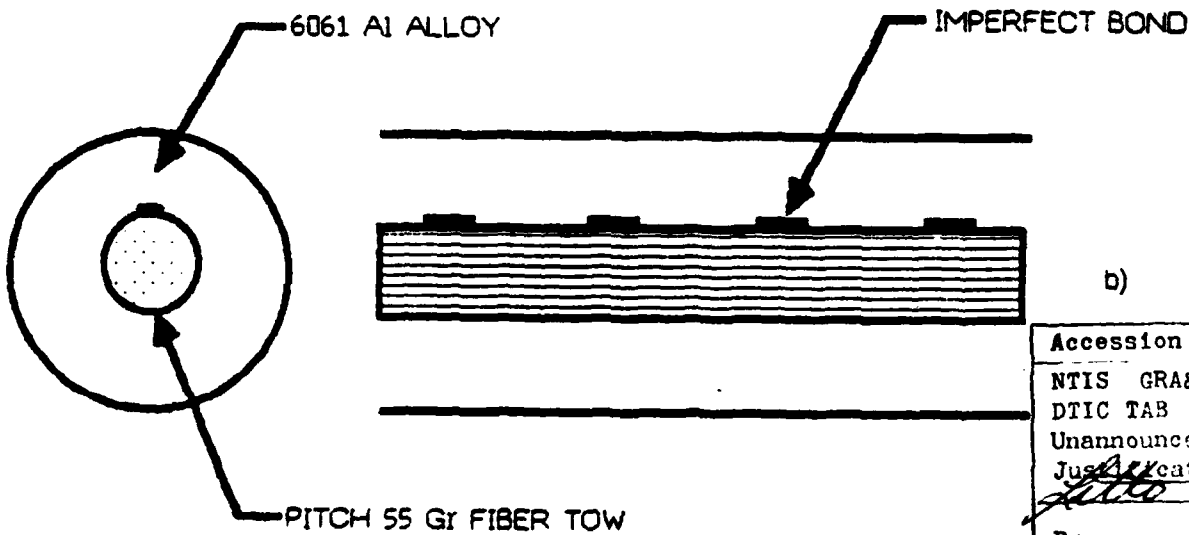
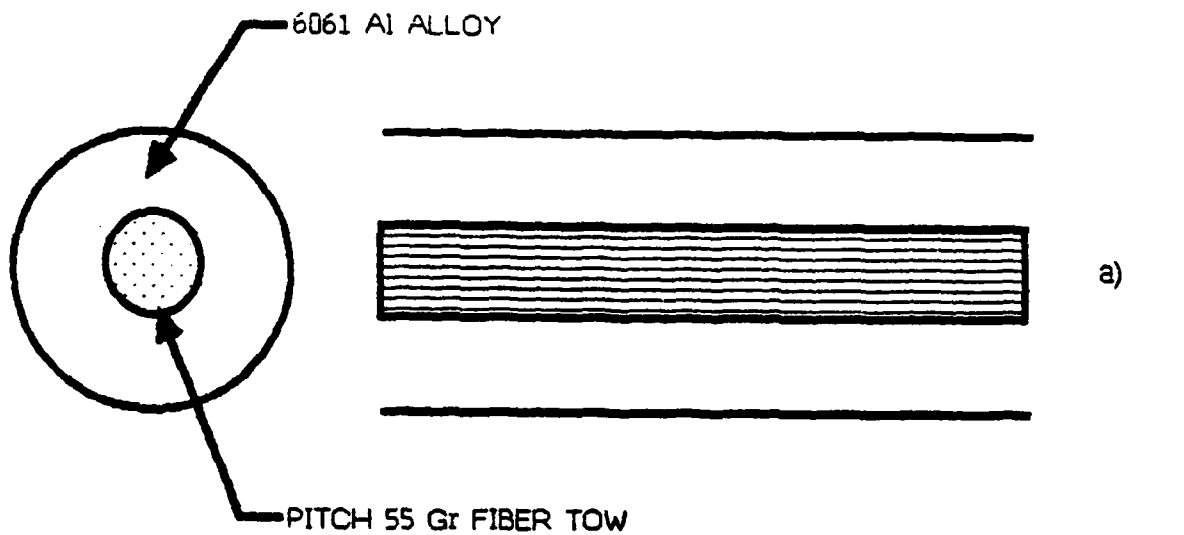

END VIEW

CROSS SECTION

Accession For	
NTIS GRA&I	<input checked="" type="checkbox"/>
DTIC TAB	<input type="checkbox"/>
Unannounced	<input type="checkbox"/>
Justification	<i>file</i>
By _____	
Distribution/ _____	
Availability Codes	
Dist	Avail and/or Special
A-1	

Figure 1 Specimen Design to Study Effects of Fiber/Matrix Bonded Interface Showing; a) Perfectly Bonded Gr/Al Precursor Wire, b) Imperfectly Bonded Gr/Al Precursor Wire.



Diffusion Bonded Interface:

- (a) A composite panel of Pitch 55 Gr/6061 (using state-of-the-art hot pressing process - Figure 2a).
- (b) A composite panel of 6061/6061 Al (Figure 2b).
- (c) An imperfectly bonded panel of Pitch 55 Gr/6061 Al.
- (d) An imperfectly bonded panel of 6061 Al/6061 Al.

4.2 Development of Test Technique

Damping data in literature has been obtained by using various test conditions, test techniques and damping parameters. In order to produce consistent damping capacity data, a reliable test method will be developed for metal matrix composites. Tests will be conducted to evaluate the frequency dependence and strain amplitude dependence of damping in MMC.

4.3 Metallurgical Characterization of the Interfaces

4.3.1 Non-destructive Examination

All specimens will be non-destructively examined by ultrasonic C-scan and X-radiography before and after damping measurements.

4.3.2 Microstructural Characterization

Specimens, after tension tests and damping tests, will be examined by scanning and transmission electron microscopy to evaluate interface integrity, interface submicrostructure, and plasticity.

4.4 Damping Mechanism(s)

Data from the damping tests of different specimens designs and as careful study of microstructural characteristics examined in 4.4 will provide a basis for the operative damping mechanism(s).

5.0 WORK ACCOMPLISHED

5.1 Literature Search

Damping capacity of viscoelastic materials and organic matrix composites has been extensively studied, though very few investigations have been conducted on metal matrix composites. On the basis of the literature search, the damping behavior of metal matrix composites could be summarized as follows:

(a) MMC exhibit a high damping capacity, when its metal matrix undergoes plastic deformation during a fatigue test (1-3). Damping tests in these investigations were conducted at 0.2% - 0.7% strain levels. A model of composite damping behavior was proposed (1-2) with the following assumptions:

(i) Bauschinger effect may be neglected;

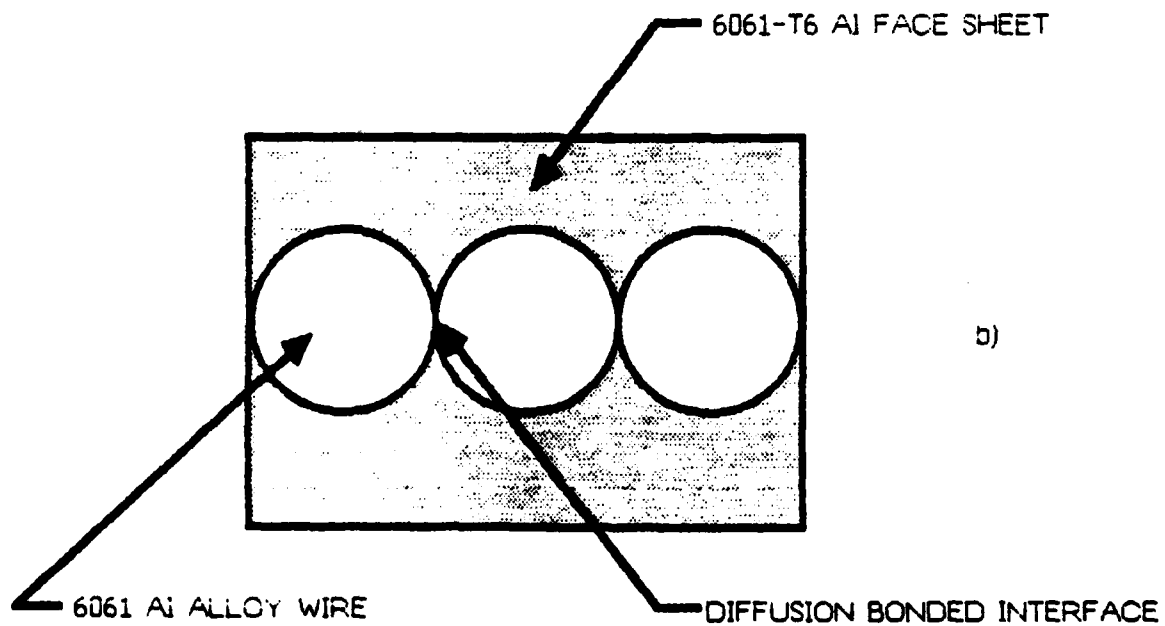
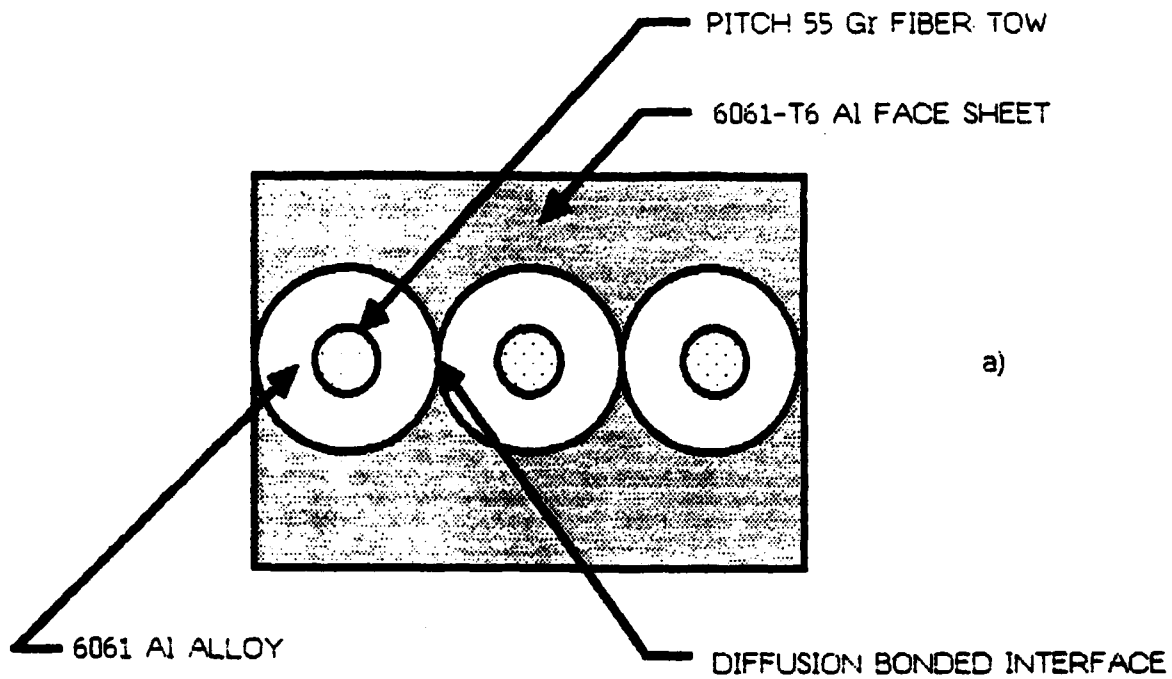

Figure 2 Specimen Design to Study Effects of Diffusion Bonded Interface Showing; a) Hot Pressed Gr/Al Composite, b) Hot Pressed Al/Al.

- (ii) A stabilized hysteresis loop exists for the matrix under cycling stress;
- (iii) The hysteresis loop shows well defined elastic and perfectly plastic region.

(b) The axial damping capacity of boron/aluminum composites is greater than the damping capacity of aluminum alloys (matrix), and significantly greater than the axial damping capacity of $\text{Al}_2\text{O}_3/\text{Al}$ and SiC/Ti composites (4-5), as shown in Figure 3. The axial damping capacity of composites can be predicted by a rule of mixture if linear anelasticity prevails (4-5). These conclusions are based on the damping tests conducted at 2000 Hz and at strain amplitudes 10^{-6} between 20°C to 500°C . It was observed during this investigation that at strain amplitude below 10^{-6} , the B/Al composite behaves like a linear anelastic solid. The enhanced damping in boron reinforced composites has been attributed to the high intrinsic damping capacity of boron fibers (6).

(c) The axial and transverse damping capacity of Gr/Al and Gr/Mg composites is greater than the damping capacity of matrix aluminum and magnesium alloys, respectively (7) (Table 1).

In general, the sources of vibrational energy dissipation at MMC can be classified in the following two categories:

- (a) Fabrication:
 - composite imperfections (voids, delamination, microcracks)
 - residual stresses
 - fiber alignment (particularly at low volume fraction)
 - fiber twist
- (b) Material:
 - fiber
 - metallic matrix

Therefore, it is possible that one or more of the damping mechanisms, such as thermo-elastic, hysteretic, coulambic, magnetoelastic, dislocation unpinning, and grain boundary relaxation, could be operative at different frequency and strain levels for the vibrational energy dissipation in metal matrix composites.

5.2 Specimen Preparation

Specimen design has been identified as the critical aspect of our technical approach and also to establish the fabrication parameters. The fiber matrix interface and diffusion bonded interface had to be accentuated to determine the effect of interface structure on the damping measurements. In order to study the contribution of constituents (fiber and matrix) damping capacity into the damping behavior of composite, few samples of reinforcing wires have been designed. The following specimen configuration will be fabricated for this study:

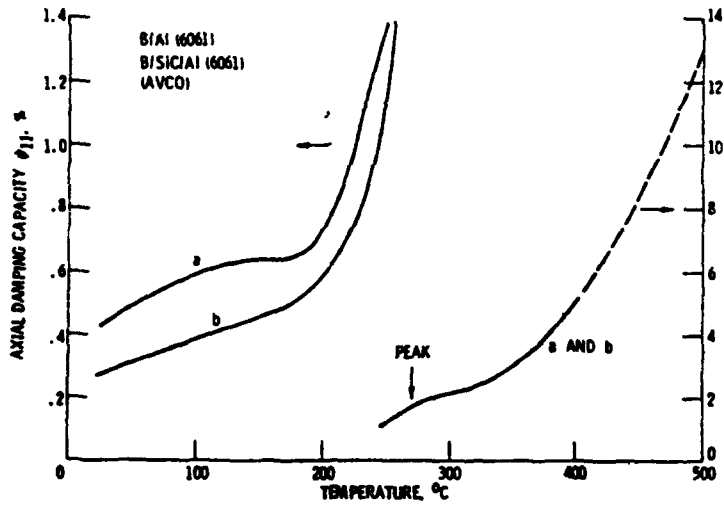

- Temperature dependence of damping for the Avco B/Al (6061) and B/SiC/Al (6061) axial specimens in the as-fabricated (curve a) and the heat-treated at 400° C (curve b) conditions. The dashed curve and curve b are damping for the B/SiC/Al (6061) specimen after heat treatment at 550° C. Measurements were made near 2000 Hz at strains $< 10^{-6}$.

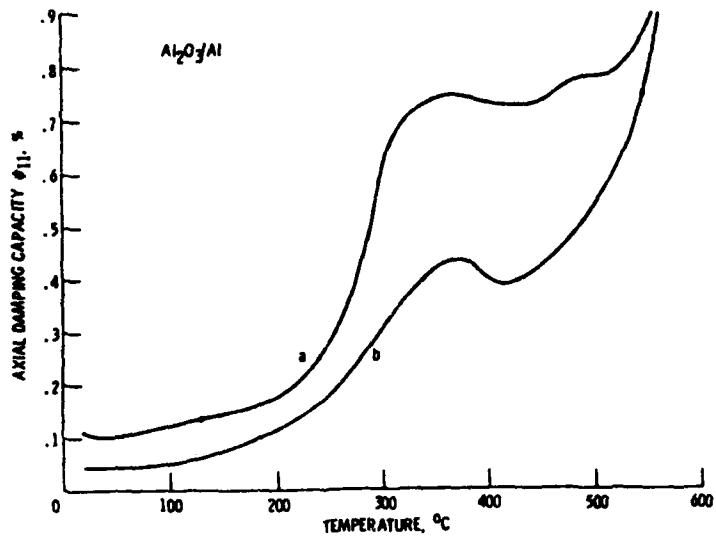

- Temperature dependence of damping for the Al_2O_3/Al axial specimen in the as-fabricated (curve a) and heat-treated at 560° C (curve b) conditions. Measurements were made near 2100 Hz at strains $< 10^{-6}$.

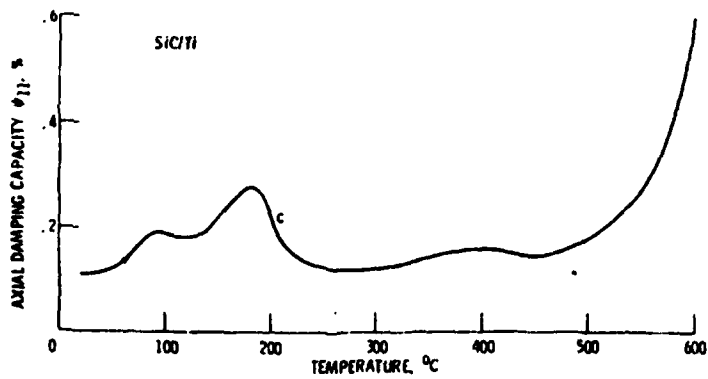

- Temperature dependence of damping for the SiC/Ti-6Al-4V axial specimen in the as-fabricated (curve a) and heat-treated at 590° C (curve b) conditions, and for the SiC/Ti axial specimen in the as-fabricated condition (curve c). Measurements were made near 2100 Hz and 1200 Hz, respectively, and at strains $< 10^{-6}$.

Figure 3 Axial Damping Capacity of B/Al, Al_2O_3/Al and SiC/Ti Alloy Composites

Table 1 - Preliminary Damping Tests Data

Damping Properties of Composites

Material	Specimen Orientation	Frequency (Hz)	Damping Factor*** (%)
*Pitch 100/AZ91C/AZ31B (26.5% v/o, Single Ply, Unidirectional)	Longitudinal	1.0	0.69
	Transverse	1.0	1.28
**Pitch 100/6061/6061 (34% v/o, Single Ply, Unidirectional)	Longitudinal	1.0	0.52
	Transverse	1.0	1.38
Pitch 100/AZ91C/AZ31B	Longitudinal	13.6	0.61
	Transverse	8.6	0.94
Pitch 100/6061/6061	Longitudinal	35.5	0.46
	Transverse	38	1.22
6061-T6 Aluminum	--	15	0.29

* 0.032"x1.0"x4.0" Specimen; 0.008 Face Sheet Thickness

** 0.038"x1/0"x4.9" Specimen; 0.011 Face Sheet Thickness

*** Damping Factor $\zeta = \frac{\delta}{2\pi}$; $\delta = \frac{1}{n} \ln \frac{A_0}{A_n}$ ($\delta = \log$ decrement), $\psi = 4\pi\zeta$

5.2.1 Composite Panels

- (A) Pitch 55 Gr/6061 aluminum composite panel with standard bond, by using state-of-the-art hot pressing process (as in Figure 2a).
- (B) Pitch 55 Gr/6061 Al composite panel with imperfect bond. This has been achieved by using low pressure and temperature conditions during hot pressing. In the fabrication of composite panel 'A', P55 Gr/6061 Al precursor wires form a good bond with the 6061 aluminum alloy face sheets and undergo complete deformation. Whereas, during the preparation of composite panel 'B', the precursor wires undergo low deformation, and the weakly bonded face sheet becomes striated between the precursor wires.
- (C) 6061 Al/6061 Al composite panel with standard bond and it does not have a fiber matrix interface (Figure 2.b.).
- (D) 6061 Al/6061 Al composite panel with imperfect bond.

5.2.2 Precursor wires

- (a) Standard Pitch 55 Gr/6061 Al wire prepared with state-of-the-art infiltration technique (Figure 1a).
- (b) Pitch 55 Gr/6061 Al wire - 50% shear deformed. These shear deformed precursor wires are flat and there is some fiber damage and disbonding introduced during processing (Figure 4).
- (c) Pitch 55 Gr/6061 Al wire - 100% shear deformed.
- (d) Standard 6061 aluminum wire.
- (e) 50% shear deformed 6061 aluminum wire.

6.0 SELECTION OF EXPERIMENTAL METHODS

The choice of a particular technique primarily depends on frequency, strain amplitude, temperature and the magnitude of damping. In damping tests, measurements are extremely sensitive to test fixtures such as gripping devices (flat vise or grips), bonded tabs, or accelerometer attachments. Parasitic energy losses due to clamping friction may erroneously indicate high material damping. It was considered best to use the free-free flexural method for damping tests and a Bruel and Kjaer company's apparatus has been set up at Texas A&M University.

Preliminary tests have been conducted by fatigue testing a tensile specimen on a MTS machine, and determine damping by measuring the area of hysteresis loop. This technique is essentially limited to low frequencies (below 10 Hz) and at strain levels above 10^{-5} .

7.0 FUTURE WORK PLAN

- (a) Non-destructive evaluation of panels and wires by high resolution x-radiography and ultrasonic C-scan.
- (b) Volume fraction analysis by using chemical and quantitative metallography methods.
- (c) Mechanical property tests (tensile modulus and strength).
- (d) Damping tests of MMC as a function of frequency for constant strain amplitude.

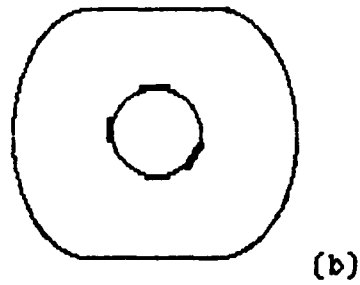
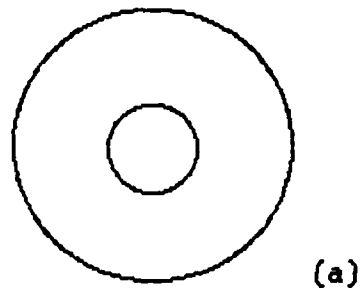

End View

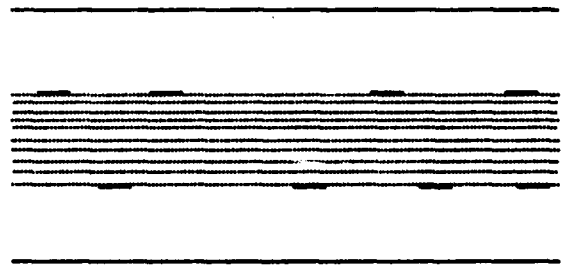

Figure 4 Pitch 55 Graphite/6061 Aluminum Precursor Wire
After Shear Deformation

- (e) Damping measurements at different strain amplitude levels 10^{-6} - 10^{-3} for a certain frequency.
- (f) Metallurgical characterization of each specimen before and after tests with specific reference to fiber-matrix interface and diffusion bonded interface.
- (g) Damping measurements of P55Gr/Al precursor wires (standard, 50% and 100% shear deformed).
- (h) Data analysis to determine the contribution of fiber and matrix damping to the damping capacity of the composite.
- (i) Investigate the operative mechanism on the basis of test data and microstructural characteristics.

8.0 REFERENCES

1. Baker, A.A. (1968), "The Fatigue of Fiber Reinforced Aluminum," J. Mat. Sci., 3(4), 412-423.
2. Varschavsky, A. (1972), "The Matrix Fatigue Behavior of Fiber Composites Subjected to Repeated Tensile Loads," J. Mat. Sci. 7(2), 159-167.
3. Weiss, H.J. (1977), "The Effect of Axial Residual Stresses on the Mechanical Behavior of Composites," J. Mat. Sci. 12(4), 797-809.
4. DiCarlo, J.A. and Maisel, J.E. (1979), "Measurement of the Time Temperature Dependent Dynamic Mechanical Properties of Boron/Aluminum Composites," ASTM STP 674, 201-227.
5. DiCarlo, J.A. and Maisel, J.E. (1979), "High Temperature Dynamic Modulus and Damping of Aluminum and Titanium Matrix Composites," NASA TM-79080.
6. DiCarlo, J.A. and Williams, W. (1980), "Dynamic Modulus and Damping of Boron, Silicon Carbide, and Alumina Fibers," presented at the Fourth Annual Conference on Composites and Advanced Materials, Cocoa Beach, FL, Jan. 20-24.
7. Misra, M.S. (1984), "Damping Behavior of Metal Matrix Composites," Vibration Damping 1984 Workshop Proceedings, AFWAL-TR-84-3064 U-1, Nov. 1984.

END

FILMED

8-85

DTIC