

1

AD-A156 251

BLACKSTONE RIVER BASIN
UPTON, MASSACHUSETTS

WILDWOOD LAKE DAM
MA 00667

**PHASE I INSPECTION REPORT
NATIONAL DAM INSPECTION PROGRAM**

DTIC
SELECTE
JUL 1 1985
G

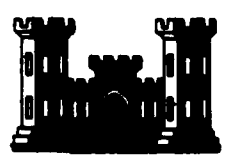

DTIC FILE COPY

DEPARTMENT OF THE ARMY
NEW ENGLAND DIVISION, CORPS OF ENGINEERS
WALTHAM, MASS. 02154

DISTRIBUTION STATEMENT A
Approved for public release;
Distribution Unlimited

APRIL 1979

85 5 28 230

JW

UNCLASSIFIED

SECURITY CLASSIFICATION OF THIS PAGE (When Data Entered)

REPORT DOCUMENTATION PAGE		READ INSTRUCTIONS BEFORE COMPLETING FORM
1. REPORT NUMBER MA 00667	2. GOVT ACCESSION NO.	3. RECIPIENT'S CATALOG NUMBER
4. TITLE (and Subtitle) Wildwood Lake Dam NATIONAL PROGRAM FOR INSPECTION OF NON-FEDERAL DAMS	5. TYPE OF REPORT & PERIOD COVERED INSPECTION REPORT	
	6. PERFORMING ORG. REPORT NUMBER	
7. AUTHOR(s) U.S. ARMY CORPS OF ENGINEERS NEW ENGLAND DIVISION	8. CONTRACT OR GRANT NUMBER(s)	
9. PERFORMING ORGANIZATION NAME AND ADDRESS	10. PROGRAM ELEMENT, PROJECT, TASK AREA & WORK UNIT NUMBERS	
11. CONTROLLING OFFICE NAME AND ADDRESS DEPT. OF THE ARMY, CORPS OF ENGINEERS NEW ENGLAND DIVISION, NEDED 424 TRAPELO ROAD, WALTHAM, MA. 02254	12. REPORT DATE April 1979	
	13. NUMBER OF PAGES 70	
14. MONITORING AGENCY NAME & ADDRESS (if different from Controlling Office)	15. SECURITY CLASS. (of this report) UNCLASSIFIED	
	15a. DECLASSIFICATION/DOWNGRADING SCHEDULE	
16. DISTRIBUTION STATEMENT (of this Report) APPROVAL FOR PUBLIC RELEASE: DISTRIBUTION UNLIMITED		
17. DISTRIBUTION STATEMENT (of the abstract entered in Block 20, if different from Report)		
18. SUPPLEMENTARY NOTES Cover program reads: Phase I Inspection Report, National Dam Inspection Program; however, the official title of the program is: National Program for Inspection of Non-Federal Dams; use cover date for date of report.		
19. KEY WORDS (Continue on reverse side if necessary and identify by block number) DAMS, INSPECTION, DAM SAFETY, Blackstone River Basin Upton, Massachusetts West River-Tributary of the Blackstone River		
20. ABSTRACT (Continue on reverse side if necessary and identify by block number) The dam is an earthfill dam with a concrete spillway located at the center of the dam. There are deficiencies which must be corrected to assure the continued performance of the dam. It is small in size with a hazard potential of significant.		

DISCLAIMER NOTICE

THIS DOCUMENT IS BEST QUALITY PRACTICABLE. THE COPY FURNISHED TO DTIC CONTAINED A SIGNIFICANT NUMBER OF PAGES WHICH DO NOT REPRODUCE LEGIBLY.



DEPARTMENT OF THE ARMY
 NEW ENGLAND DIVISION, CORPS OF ENGINEERS
 424 TRAPELO ROAD
 WALTHAM, MASSACHUSETTS 02154

REPLY TO
 ATTENTION OF
 NEEDED

JUN 18 1979

Honorable Edward J. King
 Governor of the Commonwealth of
 Massachusetts
 State House
 Boston, Massachusetts 02133

Dear Governor King:

I am forwarding to you a copy of the Wildwood Lake Dam Phase I Inspection Report, which was prepared under the National Program for Inspection of Non-Federal Dams. This report is presented for your use and is based upon a visual inspection, a review of the past performance and a brief hydrological study of the dam. A brief assessment is included at the beginning of the report. I have approved the report and support the findings and recommendations described in Section 7 and ask that you keep me informed of the actions taken to implement them. This follow-up action is a vitally important part of this program.

A copy of this report has been forwarded to the Department of Environmental Quality Engineering, the cooperating agency for the Commonwealth of Massachusetts. In addition, a copy of the report has also been furnished the owner, Town of Upton, Upton, Massachusetts 01568.

Copies of this report will be made available to the public, upon request, by this office under the Freedom of Information Act. In the case of this report the release date will be thirty days from the date of this letter.

I wish to take this opportunity to thank you and the Department of Environmental Quality Engineering for your cooperation in carrying out this program.

Sincerely yours,

[Signature]
 JOHN P. CHANDLER
 Colonel, Corps of Engineers
 Division Engineer

Incl
 as stated



Accession For	
NTIS GRA&I	<input checked="" type="checkbox"/>
DTIC TAB	
Unannounced	
Justification	
By	
Distribution/	
Availability	
Availability	
A1 23 CM	

WILDWOOD LAKE DAM

MA 00667

BLACKSTONE RIVER BASIN
UPTON, MASSACHUSETTS

PHASE I - INSPECTION REPORT
NATIONAL DAM INSPECTION
PROGRAM

NATIONAL DAM INSPECTION
PROGRAM

PHASE I INSPECTION REPORT

BRIEF ASSESSMENT

Identification No.: MA00667

Name of Dam: Wildwood Lake (Jourdan Pond)

Town: Upton

County and State: Worcester County, Massachusetts

Stream: West River - Tributary of the Blackstone
River

Date of Inspection: November 27, 1978

Wildwood Lake Dam is an earthfill dam with a concrete spillway located in the center of the dam. The dam including spillway is 430 feet long and 23 feet high above the original stream bed. The dam was constructed in 1963 on the site of an earlier dam that was washed out in 1936. The spillway is an ungated concrete ogee weir 75 feet long with a crest at elevation (El) 307.7. The outlet conduit which is 4-foot square and 18-foot long extends through the spillway and outlets on the downstream face of the weir. Flow through the conduit is regulated by a sluice gate located on the vertical upstream face of the spillway. The hand-operated mechanism for opening and closing the sluice gate is mounted on a concrete platform that overhangs the lake.

There are deficiencies which must be corrected to assure the continued performance of this dam. This conclusion is based on the visual inspection at the site, available engineering data, and review of operating and maintenance procedures. Generally, the dam is in fair condition.

The following are visible signs of distress at the site: seepage through the dam, particularly severe in an area to the right of the spillway; a large eroded area on the upstream face of the dam, above the right wing wall; vegetation growing along the water line on

WILDWOOD LAKE

the upstream face of the dam and on the right abutment of the spillway; erosion on the downstream slope of the left embankment; and minor accumulation of debris in the discharge channel.

Based on Corps of Engineers' guidelines, the dam has been classified as "small" and in the "significant" hazard category. Accordingly, a test flood equal to one-half the probable maximum flood (PMF) was used for this analysis. Hydraulic analyses indicate that the spillway can discharge a flow of 6,000 cfs with the water surface at El 315.1, which is the low point on the crest of the dam. An outflow test flood of 3,600 cfs will not overtop the dam.

It is recommended that the Owner employ a qualified consultant to investigate the seepage through the dam, and the severe erosion on the upstream face of the dam, above the right wing wall. In addition, the Owner should backfill the eroded areas on the embankment, clear the brush and trees from the right embankment and from the upstream slope of the dam, and clear the debris from the downstream channel. The Owner should also implement a systematic program of inspection and maintenance.

The recommendations and remedial measures outlined above and in Section 7 should be implemented by the Owner within a period of one year after receipt of this Phase I Inspection Report. The Owner should immediately open the sluice gate and lower the lake to El 300.0. The lake should be maintained at this level until the recommended work has been completed. An alternative to these recommendations would be to lower the lake level permanently by opening the sluice gate.

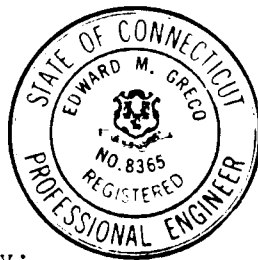

Edward M. Greco
Edward M. Greco, P.E.
Project Manager
Metcalf & Eddy, Inc.

Connecticut Registration
No. 08365

Approved by:

Stephen L. Bishop
Stephen L. Bishop, P.E.
Vice President
Metcalf & Eddy, Inc.

Massachusetts Registration
No. 19703



WILDWOOD LAKE

This Phase I Inspection Report on Wildwood Lake Dam has been reviewed by the undersigned Review Board members. In our opinion, the reported findings, conclusions, and recommendations are consistent with the Recommended Guidelines for Safety Inspection of Dams, and with good engineering judgment and practice, and is hereby submitted for approval.

Joseph A. McElroy

JOSEPH A. MCELROY, MEMBER
Foundation & Materials Branch
Engineering Division

Carney M. Terzian

CARNEY M. TERZIAN, MEMBER
Design Branch
Engineering Division

Joseph W. Finegan, Jr.

JOSEPH W. FINEGAN, JR., CHAIRMAN
Chief, Reservoir Control Center
Water Control Branch
Engineering Division

APPROVAL RECOMMENDED:

Joe B. Fryar

JOE B. FRYAR
Chief, Engineering Division

PREFACE

This report is prepared under guidance contained in Recommended Guidelines for Safety Inspection of Dams, for a Phase I Investigation. Copies of these guidelines may be obtained from the Office of Chief of Engineers, Washington, D.C. 20314. The purpose of a Phase I Investigation is to identify expeditiously those dams which may pose hazards to human life or property. The assessment of the general condition of the dam is based upon available data and visual inspections. Detailed investigations, and analyses involving topographic mapping, subsurface investigations, testing, and detailed computational evaluations are beyond the scope of a Phase I investigation; however, the investigation is intended to identify any need for such studies.

In reviewing this report, it should be realized that the reported condition of the dam is based on observations of field conditions at the time of inspection along with data available to the inspection team. In cases where the reservoir was lowered or drained prior to inspection, such action, while improving the stability and safety of the dam, removes the normal load on the structure and may obscure certain conditions which might otherwise be detectable if inspected under the normal operating environment of the structure.

It is important to note that the condition of a dam depends on numerous and constantly changing internal and external conditions, and is evolutionary in nature. It would be incorrect to assume that the present condition of the dam will continue to represent the condition of the dam at some point in the future. Only through continued care and inspection can there be any chance that unsafe conditions be detected.

Phase I inspections are not intended to provide detailed hydrologic and hydraulic analyses. In accordance with the established Guidelines, the Spillway Test Flood is based on the estimated "Probable Maximum Flood" for the region (greatest reasonably possible storm runoff), or fractions thereof. Because of the magnitude and rarity of such a storm event, a finding that a spillway will not pass the test flood should not be interpreted as necessarily posing a highly inadequate condition. The test flood provides a measure of relative spillway capacity and serves as an aid in determining the need for more detailed hydrologic and hydraulic studies, considering the size of the dam, its general conditions and the downstream damage potential.

WILDWOOD LAKE

TABLE OF CONTENTS

	<u>Page</u>
BRIEF ASSESSMENT	
PREFACE	
OVERVIEW PHOTO	iii
LOCATION MAP	iv
REPORT	
SECTION 1 - PROJECT INFORMATION	1
1.1 General	1
1.2 Description of Project	1
1.3 Pertinent Data	6
SECTION 2 - ENGINEERING DATA	10
2.1 General	10
2.2 Construction Records	10
2.3 Operating Records	10
2.4 Evaluation	11
SECTION 3 - VISUAL INSPECTION	12
3.1 Findings	12
3.2 Evaluation	15
SECTION 4 - OPERATING PROCEDURES	16
4.1 Procedures	16
4.2 Maintenance of Dam	16
4.3 Maintenance of Operating Facilities	16
4.4 Description of Any Warning System in Effect	16
4.5 Evaluation	16
SECTION 5 - HYDRAULIC/HYDROLOGIC	17
5.1 Evaluation of Features	17

WILDWOOD LAKE

TABLE OF CONTENTS (Continued)

	<u>Page</u>
SECTION 6 - STRUCTURAL STABILITY	20
6.1 Evaluation of Structural Stability	20
SECTION 7 - ASSESSMENT, RECOMMENDATIONS, AND REMEDIAL MEASURES	22
7.1 Dam Assessment	22
7.2 Recommendations	23
7.3 Remedial Measures	23
7.4 Alternatives	24
APPENDIXES	
APPENDIX A - PERIODIC INSPECTION CHECKLIST	
APPENDIX B - PLANS OF DAM AND PREVIOUS INSPECTION REPORTS	
APPENDIX C - PHOTOGRAPHS	
APPENDIX D - HYDROLOGIC AND HYDRAULIC COMPUTATIONS	
APPENDIX E - INFORMATION AS CONTAINED IN THE NATIONAL INVENTORY OF DAMS	

WILDWOOD LAKE

**OVERVIEW
WILDWOOD LAKE DAM
UPTON, MASSACHUSETTS**



Early inspection reports on the former dam at this site made frequent reference to leaks through the toe of the dam, and bulging in the downstream wall, particularly along the northerly end of the wall. The wall was apparently repaired in 1928, but the problem of leakage persisted up to the time that the dam failed in 1936. The seepage observable in the present dam may also be caused by leaks through the remains of the old embankment.

There is a large hole, approximately 6 feet in diameter and 2 feet deep, on the upstream face of the dam above the right wing wall of the spillway. The hole is believed to be due to erosion. The chainlink fence along the wing wall and outlet works has been partially dismantled and should be replaced.

There are bushes growing in the riprap along the present water line on the upstream face of the dam. These should be removed, as well as the heavy accumulation of brush on the downstream slope in the main seepage area. A few trees on the downstream slope of the left embankment should also be cleared.

The crest of the dam is clear, and there is some evidence of vehicular traffic on both embankments, probably originating from the nearby DPW Garage, and the picnic area adjacent to the right abutment. Foot traffic has also eroded a path across the downstream slope of this embankment. This minor erosion on the crest and slopes does not appear to be a problem.

- c. Appurtenant Structures. The spillway is a 75-foot long concrete ogee weir located about 150 feet from the south abutment of the dam. A flat concrete apron extends about 36 feet beyond the toe of the spillway. Beyond the end of the apron the spillway discharges into an earth and rock channel. The weir and the apron are bounded by concrete side walls. The spillway appears to be in good condition, except for minor erosion of the concrete at the base of the side walls.

SECTION 3
VISUAL INSPECTION

3.1 Findings

- a. General. The Phase I Inspection of the dam at Wildwood Lake was performed on November 27, 1978. A copy of the inspection check list is included in Appendix A. Previous inspections of the former dam at this site have been made by others since 1925. A partial listing of these inspections is in Appendix B. An inspection was made in 1963 during construction of the new dam, and again in 1972 by personnel from the Massachusetts Department of Public Works. Copies of their reports are included in Appendix B.
- b. Dam. Wildwood Lake Dam consists of an earth-fill embankment with a concrete spillway located in the center of the dam. Concrete cutoff walls extend into the embankment from each side of the spillway. The present dam was constructed over the remnants of a previous dam that had been washed out in 1936. A 1936 County inspection report described the former dam as an earth embankment with reinforced concrete walls on the upstream and downstream slopes. Figure B-5, however, indicates that some walls were of masonry construction. A 15-foot section of stone wall on the downstream slope of the left embankment was observed during the inspection. According to Figure B-5, the embankment was constructed with gravel borrow at the toe, beyond the old wall.

The dam appears to be in fair condition, however, several signs of distress were noted at the site. Seepage through the dam has created a large wet area on the downstream slope of the embankment, to the right of the spillway. This area is overgrown with brush and marsh vegetation and the ground is spongy and soft. A second, smaller area of seepage was apparent in the riprap below the left retaining wall of the spillway.

WILDWOOD LAKE

2.4 Evaluation

- a. Availability. There is engineering data available on the design of the spillway.
- b. Adequacy. The available hydraulic, structural, and construction data were reviewed. The evaluation of the adequacy of this dam is based on review of available drawings and computations, visual inspection, past performance history, and engineering judgment.
- c. Validity. Comparison of the available drawings with the field survey conducted during the Phase I inspection indicates that the information is valid.

SECTION 2

ENGINEERING DATA

2.1 General. There were two sets of drawings available for this dam at the Worcester County Commissioners Office. One set is dated December 1936, and shows the proposed plan for rebuilding the dam. Apparently this design was never used. The second set consists of seven sheets of design drawings, dated 1959, by Green Engineering Affiliates, Inc. A copy of this set is included in Appendix B. There were no as-built drawings available. Hydraulic and stability computations on file at Green Engineering (now known as Green International Affiliates, Inc.) were also reviewed for this report. Standard specifications by the Massachusetts Division of Waterways were used for construction of this dam.

We acknowledge the assistance and cooperation of personnel of the Massachusetts Department of Public Works and of the Massachusetts Department of Environmental Quality Engineering, Division of Waterways.

Also, we acknowledge the cooperation and assistance of personnel from the Worcester County Engineer's Office.

In addition, we thank Messrs. James Bates and Henry Poirier, of the Town of Upton who provided information on the history of the operation and past performance of the dam.

We also acknowledge the assistance of personnel from Green International Affiliates, Inc., who provided the available design data.

2.2 Construction Records. The only construction records are the 1959 Plans referred to in section 2.1 and included in Appendix B. There are no as-built drawings for the dam, spillway or outlet structures.

2.3 Operating Records. No operating records are available, and there is no daily record kept of the elevation of the pool or rainfall at the dam site.

WILDWOOD LAKE

- (5) Upstream channel: concrete wing walls on upstream face of dam. Lake bed graded to El 295.0 at spillway.
- (6) Downstream channel: Broad, gently sloping concrete apron extends 36 feet from toe of weir, leads to 75-foot wide discharge channel partially paved with riprap. Channel narrows to 25 feet.
- (7) General: Baker Pond located 400 feet downstream, concrete box culvert under Williams Street, 1,500 feet downstream. Baker Pond Dam below Williams Street.

j. Regulating Outlets. The regulating outlet at the dam is a 4-foot square conduit through the spillway, adjacent to the south side wall. The conduit is shown on the drawings to be 18 feet long with an invert at El 296.0. The inlet to the conduit is located on the vertical upstream face of the weir, and the outlet on the downstream face.

Flow through the conduit is controlled by a 4-foot square sluice gate on the upstream face of the weir. The gate is operated by a hand crank located on a concrete platform overhanging the upstream face of the dam.

WILDWOOD LAKE

f. Reservoir Surface (acres)

- *(1) Top dam: 36
- *(2) Test flood pool: 36
- (3) Flood-control pool: N/A
- (4) Recreation pool: 36
- (5) Spillway crest: 36

g. Dam

- (1) Type: earthfill
- (2) Length: 430 feet
- (3) Height: 23 feet
- (4) Top width: 15 feet
- (5) Side slopes: upstream and downstream
2.5:1
- (6) Zoning: homogeneous impervious fill
- (7) Impervious core: earth
- (8) Cutoff: cutoff trench 2 to 4 feet deep
beneath centerline of embankment; 15-foot
long cutoff wall on each side of spillway
- (9) Grout curtain: none.

i. Spillway

- (1) Type: ogee
- (2) Length of weir: 75 feet
- (3) Crest elevation: 307.7 MSL (assumed bench-
mark)
- (4) Gates: None

*Based on the assumption that the surface area will not increase significantly with changes in reservoir elevation from 307.7 to 315.1.

WILDWOOD LAKE

spillway crest. This elevation was shown on drawings of the dam dated 1959 (see Figure B-4).

- (1) Top dam: 315.1 to 316.5
- (2) Test flood pool: 313.0
- (3) Design surcharge (1958 design): Maximum Design Flow El 313.15
- (4) Full flood control pool: Not Applicable (N/A)
- (5) Recreation pool: 307.7
- (6) Spillway crest (ungated): 307.7
- (7) Upstream portal invert diversion tunnel: N/A
- (8) Stream bed at centerline of dam: 292.0
- (9) Maximum tailwater: 294.4

d. Reservoir

- (1) Length of maximum pool: 5,200 feet
- (2) Length of recreation pool: 5,200 feet
- (3) Length of flood control pool: N/A

e. Storage (acre-feet)

- (1) Test flood surcharge (Net): 192 at El 313.0
- (2) Top of dam: 460
- (3) Flood control pool: N/A
- (4) Recreation pool: 190 (Approximate)
- (5) Spillway crest: 190

WILDWOOD LAKE

1. Normal Operating Procedure. There is no standard operating procedure at the dam. The new dam was completed in 1966, and since that time the gate has been kept closed. There are no provisions for flashboards on the spillway.

1.3 Pertinent Data

- a. Drainage Area. The drainage area for Wildwood Lake covers about 4,896 acres (7.65 square miles). Miscoe Brook and the West River flow roughly north to south in a broad swampy flood plain. Cider Mill Pond and Silver Lake, upstream of Wildwood Lake, were also formed by dams on the West River. The remaining drainage area is comprised of farm and woodland with slopes ranging from 5 to 15 percent. Limited residential development occurs on the east side of Pigeon Hill, in the north, and along Route 140 and several secondary roads. The Massachusetts Turnpike crosses the watershed at the northern end, and a high tension line at the southern end.

- b. Discharge. Normal discharge is over the un-gated ogee spillway. The spillway is 75 feet long, with a crest at El 307.7. Water flows down the 13-foot high surface of the weir, and over a concrete apron which extends for 57.5 feet from the upstream wall of the weir. At the toe of the apron the water enters the discharge channel. The channel is 75 feet wide and lined with rock fill and boulders at the toe of the spillway. Beyond 90 feet, however, the channel narrows to a 25-foot wide stream that flows through woodland to Baker Pond, about 400 feet downstream.

The spillway can discharge an estimated 6,000 cfs with the water surface at El 315.1 which is the low point on the crest of the dam. The outflow test flood (one-half PMF) is 3,600 cfs at El 313.0 and will not overtop the dam.

The maximum flood level at the present dam is unknown. The original dam was overtopped and washed out in the 1936 flood.

- c. Elevation (feet about Mean Sea Level (MSL)).
A benchmark was established at El 307.7 on the

WILDWOOD LAKE

even a dance pavilion on the island. The Lake Wildwood Improvement Association purchased the property in 1934, after the mills closed.

The dam failed during a flood on March 12, 1936. The reports of the failure are incomplete, but apparently the dam failed due to overtopping. One report suggested also that ice on the lake may have had a part in the failure. Reports on the condition of the dam after the flood are conflicting. One states that the breached section was 70 feet long, while another says only one abutment of the spillway remained. The 1960 plans of repairs show the remnants of a concrete abutment to the right of the stream, and of a concrete wall on the left side.

Shortly after the failure, plans for reconstruction of the dam were submitted to the Worcester County Commissioners, but the dam was never built. Eventually the Lake Wildwood Improvement Association went bankrupt and sold the property in 1946.

The Town of Upton acquired the property in 1956. The lake bed was by this time overgrown with trees and brush, and heavily silted in.

In 1958 Green Engineering Affiliates conducted a study on the proposed repairs to the dam at Jourdan Pond (Wildwood Lake). A copy of their preliminary report is included in Appendix B. The present dam was built in 1963 by the Massachusetts Division of Waterways, and designed by Green Engineering. Available information indicated that debris and remnants of the old dam were excavated only when necessary. Figure B-4 shows a typical section of the dam, and indicates that the new embankment was constructed slightly upstream of the old one, and that part of the former embankment and stone wall has been incorporated into the dam. Rubble stone that had been washed from the embankment during the flood was used as riprap on the slopes, and in the discharge channel. There has been no other work on the dam since its completion.

WILDWOOD LAKE

- d. Hazard Classification. The discharge channel from Wildwood Lake Dam flows through a wooded area bounded by open fields. Baker Pond is a small pond located about 400 feet below Wildwood Lake. The pond is formed by a second dam on the West River, south of Williams Street. According to the water superintendent for the Town of Upton, the Baker Pond Dam is in very poor condition. Failure of the dam at Wildwood Lake would cause flooding of Baker Pond. The flow would probably be impeded by the culvert under Williams Street and by Baker Pond Dam. There is, however, a possibility of flood damage to homes along the river and on Glen Avenue in West Upton, particularly if the Baker Pond Dam were to fail. For these reasons the dam at Wildwood Lake has been placed in the "significant" hazard category.
- e. Ownership. The dam is owned by the Town of Upton, Massachusetts (617-529-3565, Town Clerk). Mr. Aldo Consigli, Chairman of the Board of Selectmen, granted permission to enter the property and inspect the dam. There is, however, a long-standing dispute between the Town and the State of Massachusetts over the responsibility for operation and maintenance of the dam.
- f. Operator. The Highway Superintendent, who is also the Water Superintendent, is the designated operator of the dam.
- g. Purpose of the Dam. The construction of the existing dam was completed in 1966; the lake is currently used for recreational activities such as swimming and fishing.
- h. Design and Construction History. There have been two other dams located at this site. The first, which was built in 1833, was replaced in 1851 by a stone masonry and earth structure. The reservoir behind the second dam covered 48 acres and was used for power by various industries. Until 1930 the lake was the property of the Smith Mills. Lake Wildwood became well known as a recreational center in the early part of this century, with cottages, fishing and boating facilities, and

side walls. The concrete apron is 2 feet thick over a gravel bed. At the downstream end of the apron a concrete cutoff extends 5 feet below the bottom of the spillway slab. The apron has been constructed with two rows of 4-inch weep holes spaced on 15-foot centers. In addition, the underdrain system for the spillway includes a 6-inch diameter perforated pipe located behind the cutoff wall at the upstream end of the weir. The perforated pipe drains to 6-inch diameter lateral pipes which discharge downstream of the apron. Figure B-3 also shows perforated drain pipe outside of the sidewalls to the spillway.

The spillway discharges into the stream channel at the toe of the apron. The beginning of the channel is paved with riprap for a distance of about 10 feet. There is also riprap placed along the toe of the retaining wall. The channel is about 75 feet wide directly below the spillway and has steep earth slopes that are partly covered with boulders. The floor of the channel is covered with sand, gravel and boulders. The width of the channel is reduced to 25 feet, about 90 feet downstream from the toe of the apron.

The outlet for Wildwood Lake is a 4-foot square 18-foot long opening which extends through the spillway adjacent to the right side wall. The upstream end of the outlet is on the vertical upstream face of the spillway. Figure B-9 shows a trash rack covering the inlet. The outlet has an upstream invert at El 296.0. The outlet end is located on the downstream face of the spillway. Flow through the outlet is controlled by a 4-foot square sluice gate at the upstream face of the spillway. The gate is operated by a hand-operated crank mounted on a concrete platform which overhangs the upstream face of the spillway.

- c. Size Classification. Wildwood Lake Dam is classified in the "small" category since it has a maximum height of 23 feet and a maximum storage capacity of 460 acre-feet.

the Town of Upton, Worcester County, Massachusetts (see Location Map and Drainage Area Map in Appendix D).

- b. Description of Dam and Appurtenances. Wildwood Lake Dam is an earthfill dam with a concrete spillway section, totalling 430 feet long and a maximum height of 23 feet above the original stream bed. (See Figures B-1 through B-6). The crest of the dam averages 15 feet wide. The elevation of the crest varies from 315.1 near the spillway, to 316.5 at the right abutment. The embankment is constructed of impervious fill. A cutoff trench beneath the embankment extends 2 to 4 feet into material indicated as sand, gravel and boulders on the boring logs shown on Figure B-3. The upstream side of the embankment slopes at 2.5:1. The downstream slope varies from 2.5:1 to slightly flatter. The upstream slope is covered with a gravel bedding and riprap from the toe to about 2 feet above the normal water line. The crest and downstream slopes are covered with grass. A drainage swale has been constructed of concrete on the downstream slope of the left embankment. A concrete cutoff wall which extends 15 feet from each abutment of the spillway, is located at the center of the embankment.

The entrance to the spillway has concrete wing walls that extend for 31 and 42 feet along the upstream face of the dam. As shown in Figure B-6, there is no approach channel;. The upstream face of the spillway is a vertical concrete wall about 13 feet high. Figure B-6 indicates a 7-foot deep cutoff below the upstream end of the spillway. The spillway is a concrete ogee weir with concrete side walls. The crest of the weir is 75 feet long and is at El 307.7.

The downstream face of the spillway is a steep slope leading over a "bucket deflector" radius and onto a gently sloping apron. The side walls continue downstream from the lip of the bucket for the length of the apron, a distance of 36 feet, and terminate at 11-foot long retaining walls on the downstream face of the dam. These walls are at right angles to the

WILDWOOD LAKE

NATIONAL DAM INSPECTION
PROGRAM

PHASE I INSPECTION REPORT

WILDWOOD LAKE

SECTION 1

PROJECT INFORMATION

1.1 General

- a. Authority. Public Law 92-367, August 8, 1972, authorized the Secretary of the Army, through the Corps of Engineers, to initiate a national program of dam inspection throughout the United States. The New England Division of the Corps of Engineers has been assigned the responsibility of supervising the inspection of dams within the New England Region. Metcalf & Eddy, Inc. has been retained by the New England Division to inspect and report on selected dams in the State of Massachusetts. Contract No. DACW 33-79-C-0016 dated November 28, 1978 has been assigned by the Corps of Engineers for this work.
- b. Purpose:
- (1) Perform technical inspection and evaluation of non-Federal dams to identify conditions which threaten the public safety and thus permit correction in a timely manner by non-Federal interests.
 - (2) Encourage and assist the States to initiate quickly effective dam safety programs for non-Federal dams.
 - (3) Update, verify and complete the National Inventory of Dams.

1.2 Description of Project

- a. Location. The dam is located on the West River, a tributary of the Blackstone River, in

WILDWOOD LAKE

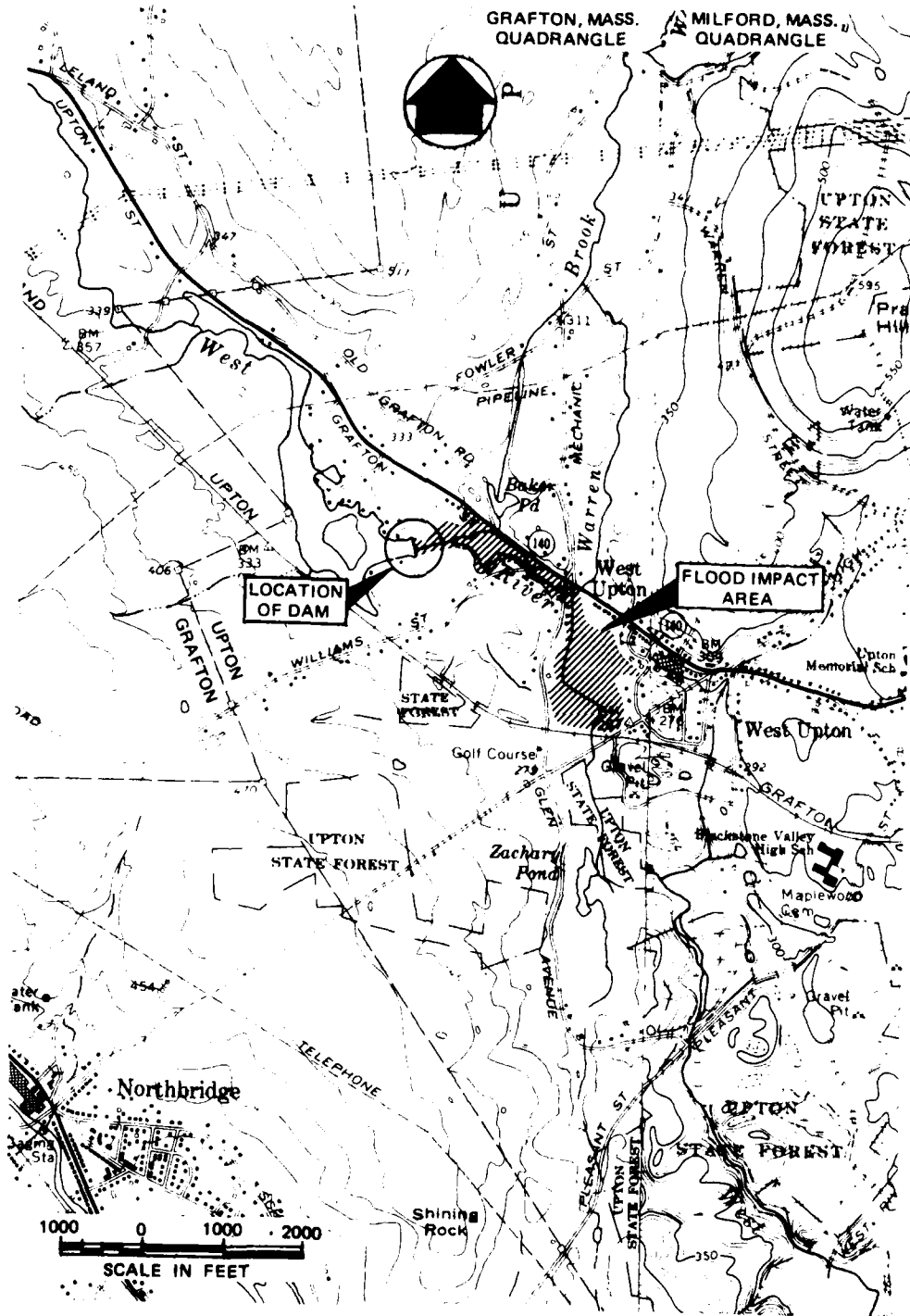

LOCATION MAP - WILDWOOD LAKE DAM

The outlet conduit is a 4-foot square opening which extends through the spillway and discharges at the downstream face of the weir.

The visible concrete appears to be in good condition. Water flowing over the weir prevented a closer inspection of the outlet, and the gated inlet was submerged. The hand operated sluice gate mechanism is standing on an open platform which overhangs the lake. The mechanism is unlocked, but the hand crank is not kept at the site. The gate apparently has not been opened since the dam was built. Its condition is unknown.

- d. Reservoir Area. Development in the Wildwood Lake area is limited to the east side of the lake, near Route 140, and along Williams Street, in the south. Future development is possible along the west shore of the lake, but at the present time there are no roads. This area is generally wood and farm land, with slopes of 5 to 8 percent adjacent to the pond.
- e. Downstream Channel. Discharge from the spillway and outlet flows over the concrete apron of the weir, and enters the channel of the West River. The width of the channel is reduced from 75 to 25 feet about 90 feet downstream. The upper 10 feet of the discharge channel is protected with riprap on the floor and boulders on the banks, apparently all debris from the former dam at this site. The remainder of the channel has a natural pavement of sand, gravel, and cobbles, and earth slopes. Sections of the banks beyond the riprap are undercut, exposing the roots of trees which overhang the channel. A footbridge of rocks and debris has been constructed across a narrow section of the channel, about 150 feet downstream of the dam. This minor amount of debris does not appear to obstruct flow. Elsewhere the channel is clear.

About 400 feet downstream of the dam, the stream, which is the West River, enters Baker Pond. The outlet for this pond is restricted by a concrete culvert under Williams Street.

WILDWOOD LAKE

The dam for Baker Pond is downstream of this culvert, and according to Town Personnel, this lower dam is in very poor condition.

The river flows in a shallow, rocky channel under a bridge on Glen Avenue before entering the floodplain for the West Hill Flood Control Reservoir. There are about five homes on the east side of Glen Avenue, adjacent to the flood plain, which could be endangered in a flood.

- 3.2 Evaluation. The above findings indicate that the dam is in fair condition, but there are several deficiencies which require attention. Apparently there is no established maintenance program at this site.

Recommended measures to improve these conditions are stated in Section 7.3.

WILDWOOD LAKE

SECTION 4

OPERATING PROCEDURES

- 4.1 Procedures. Since the new dam was completed (about 1966) the normal procedure has been to keep the outlet gate closed and allow the ungated spillway to discharge flow over the crest.
- 4.2 Maintenance of Dam. There is no regular maintenance procedure at the dam. The town owns a small park adjacent to the south abutment of the dam that is well-maintained by the Conservation Commission and the Tree Warden. Apparently no work has been done on the dam since its completion. An eroded area on the upstream slope of the dam has not been filled in, and the chainlink fence along the right wing wall, which was torn at some time, has not been replaced.
- 4.3. Maintenance of Operational Facilities. The gate appears to be in good condition, but reportedly has not been used since its installation. No problems have been reported at the outlet or on the spillway since the dam was built.
- 4.4 Description of Any Warning System in Effect. There is no warning system in effect at this dam. One of the Town selectmen indicated that the Water Superintendent is relied upon to open the gate when he deems it necessary.
- 4.5 Evaluation. There is no regular program of maintenance or a warning system in effect at Wildwood Lake Dam. Apparently there is a long-standing dispute between the Town and State over who is actually responsible for the operation and maintenance of this facility. This is undesirable considering the dam is in the "significant" hazard category. A program of inspection and maintenance and a surveillance system for this dam should be implemented as recommended in Section 7.3.

WILDWOOD LAKE

SECTION 5

HYDRAULIC/HYDROLOGIC

5.1 Evaluation of Features

- a. General. The drainage area for Wildwood Lake includes two smaller ponds on the West River: Cider Mill Pond, which is largely silted up, and Silver Lake. The West River and Miscoe Brook drain several large swampy areas in the northern part of the watershed before joining north of Cider Mill Pond. The dam at Wildwood Lake was constructed in 1963 to replace one that was washed out in the flood of March 1936. The new dam is an earth embankment with a central concrete spillway. The crest of the weir is 75-feet long and at El 307.7. This was also the elevation of the original spillway at this site. There are no provisions for flashboards on the weir. There is a concrete apron at El 292.0 at the toe of the weir. The weir and apron are bounded by sloping concrete side walls. Discharge from the lake flows over the weir and the apron and into an earth channel. The channel is 75-feet wide and lined with riprap at the upper end. Approximately 90 feet downstream from the toe of the apron, the width of the channel is reduced to about 25 feet. The stream channel, which is the West River, flows 400 feet through woodland to Baker Pond.
- b. Design Data. Hydraulic computations were reviewed, and are available at the office of Green International Affiliates, Inc. The maximum design discharge for the spillway was calculated to be 3,600 cfs at a head of 5.45 feet. Based on a spillway crest elevation of 307.7, the design flood elevation was computed to be 313.15. The upstream riprap does not extend this high.
- c. Experience Data. Hydraulic records are not available for this dam.

WILDWOOD LAKE

- d. Visual Observations. The dam is relatively new, and the spillway appears to be in good condition. There is no approach channel, and the entrance to the spillway is clear except for minor amounts of debris floating near the crest of the weir. The outlet conduit extends through the spillway and discharges at the downstream face. The mechanism for operating the gate appears to be in good condition, although it is reported that the gate has not been opened since the dam was built. The narrow discharge channel shows some erosion of its banks. Local accumulations of rock and debris do not appear to impede the flow in the channel.
- e. Test Flood Analysis. The Probable Maximum Flood (PMF) rate was determined to be 1,000 cfs per square mile. This calculation is based on the average slope of the drainage area of 1.5 percent, the pond-plus-swamp area to drainage area ratio of 10 percent, and the U.S. Army Corps of Engineers' guide curves for Maximum Probable Flood Peak Flow Rates (dated December 1977). Applying one-half the PMF to the 7.65 square miles of drainage area results in a calculated peak flood flow of 3,800 cfs as the inflow test flood. By adjusting the inflow test flood for surcharge storage, the maximum discharge rate was established as 3,600 cfs (472 cfs per square mile), with a water surface at El 313.0.

Hydraulic analyses indicate that the spillway could discharge 6,000 cfs when the water surface is at El 315.1 which is the low point on the crest of the dam. This discharge exceeds the outflow test flood of 3,600 cfs. Using the outflow test flood, the pond level would be 2.1 feet below the low point on the crest (El 313.0). The outflow test flood of 3,600 cfs is the same as the design flood for the spillway.

The 4-foot square outlet through the spillway has a capacity of 300 cfs with the water surface at El 307.7. The lake could be lowered 1 foot below the spillway crest in about 1-1/2 hours.

WILDWOOD LAKE

- f. Dam Failure Analysis. The discharge rate due to failure of the dam was calculated with the water surface at El 313.0, which is the lake level during the test flood. The total flow, would be approximately 13,300 cfs, with a maximum river depth of 12 feet. This flow rate includes 3,600 cfs discharging through the spillway and a depth of flow of 7.5 feet in the downstream channel, prior to failure of the dam. At 400 feet downstream of the dam, the flood wave would flow into Baker Pond, and be partially restricted by the culvert under Williams Street. The resulting backup into Baker Pond could cause flooding along Route 140. There is also a potential for damage to the buildings in West Upton, particularly three homes along Glen Avenue. For these reasons, the dam has been placed in the "significant" hazard category.

SECTION 6

STRUCTURAL STABILITY

6.1 Evaluation of Structural Stability

- a. Visual Observations. The evaluation of the structural stability of Wildwood Lake Dam is based on review of the available drawings and computations, and the visual inspection conducted on November 27, 1978. As discussed in Section 3, Visual Inspection, the dam is in fair condition, however, seepage through the downstream face of the dam could indicate an unfavorable situation. Accordingly, it is recommended that this condition be evaluated further.

- b. Design and Construction Data. There are seven sheets of drawings dated 1959 available from the County on the design of this dam (see Figures B-3 through B-9). Structural computations by Green Engineering Affiliates, Inc., on the stability of the concrete spillway side walls and retaining walls were reviewed. The computations appear to be in conformance with current design procedures. These are the only plans, specifications, or computations available on the design and construction of this dam from the Owner, State, or County, or Green Engineering Affiliates, Inc. There were no computations available regarding the stability of the earth dike.

Information does not appear to exist on the type, shear strength, and permeability of the soil and/or rock materials of the embankment. The drawings note the embankment material as impervious borrow.

Wildwood Lake Dam was constructed in 1963 to replace an earlier dam that had been washed out in 1936. The present dam is partially built over the remains of the former dam including part of a downstream retaining wall. According to the boring logs shown in Figure B-3, the foundation material is sand, gravel, and boulders. The design drawings indicate a cutoff trench 2 to 4 feet deep under the

WILDWOOD LAKE

centerline of the dam. There is also a concrete cutoff wall that extends 15 feet into the embankment from each wall of the spillway.

The foundation of the spillway is apparently keyed into undisturbed material consisting chiefly of sand and gravel. There is also a 5-foot deep cutoff wall at the toe of the spillway apron.

- c. Operating Records. There is no instrumentation of any type in Wildwood Lake Dam, and no instrumentation was ever installed in this dam. The performance of this dam under prior loading can only be inferred by physical evidence at the site.
- d. Post-Construction Changes. There are no as-built drawings available for Wildwood Lake Dam. Based on the visual evidence, and field measurements, the dam appears to be built essentially as shown on the 1959 drawings.
- e. Seismic Stability. Wildwood Lake Dam is located in Seismic Zone 2. Because the dam is classified as "small" and retains a low head of water, seismic analysis is not warranted.

WILDWOOD LAKE

SECTION 7

ASSESSMENT, RECOMMENDATIONS, AND REMEDIAL MEASURES

7.1 Dam Assessment

- a. Condition. Based upon a review of available drawings, the visual inspection of the site, and from the limited operational or maintenance information, there are deficiencies which must be corrected to assure the continued performance of this dam. Generally, the dam is considered to be in fair condition. The major problem at the site is the amount of seepage through the embankment on both sides of the spillway, but particularly on the right side. Other signs of distress were the erosion on the upstream face, to the right of the spillway; the bushes growing along the upstream face of the dam at the water line; dense growth of brush on the slope of the right abutment (in the vicinity of the seepage); erosion on the downstream slope of the left embankment; and minor accumulation of debris in the downstream channel.

Hydraulic analyses indicate that the spillway can discharge a flow of 6,000 cfs with the water surface at El 315.1 which is the low point on the crest of the dam. An outflow test flood of 3,600 cfs (one-half the probable maximum flood) will not overtop the dam.

- b. Adequacy. The available hydraulic, structural, and construction data were reviewed. The evaluation of the adequacy of this dam is based on review of available drawings, and computations, visual inspection, past performance and engineering judgment. The information is considered adequate for a Phase I inspection.
- c. Urgency. The recommendations and remedial measures outlined below should be implemented by the Owner within 1 year after receipt of this Phase I Inspection Report.
- d. Need for Additional Investigation. Additional investigations to further assess the

WILDWOOD LAKE

adequacy of the dam are outlined below in Section 7.2, Recommendations.

- 7.2 Recommendations. In view of the concerns on the continued performance of this dam, it is recommended that the Owner employ a qualified consultant to investigate the seepage through the dam, and the severe erosion on the upstream face of the dam near the right spillway wing wall.
- 7.3 Remedial Measures. The dam is about 12 years old and has not yet required any major repairs. It is recommended, however, that the Owner accomplish the following:
- a. open the sluice gate and lower the lake to El 300.0, which is approximately 8 feet below the crest of the spillway. The lake should be maintained at this level until the recommendations and following remedial measures are implemented.
 - b. add riprap to the upper slope of the upstream face of the dam. This would provide complete riprap protection for the entire face of the dam.
 - c. backfill and protect the eroded area on the upstream face of the dam, adjacent to the spillway. Also, repair the erosion on the downstream face of the embankment.
 - d. clear brush and trees from the upstream face near the water line, and from the downstream face of the right abutment.
 - e. clear the accumulated debris from the downstream channel.
 - f. repair the fence on the wing wall of the spillway.
 - g. implement a systematic program of maintenance inspections. As a minimum, the inspection program should consist of a monthly inspection of the dam and appurtenances. It is essential that a department in the Town be assigned permanent responsibility for maintaining the dam and operating the gate. All

WILDWOOD LAKE

repairs and maintenance should be undertaken in accordance with all applicable State regulations.

- h. periodic technical inspections of this dam should be continued on an annual basis.
- i. institute a definite plan for surveillance and a warning system during periods of unusually heavy rains and/or runoff.

7. Alternatives. The alternative to implementing the recommendations and maintenance procedures listed above would be to lower the lake level permanently, by opening the sluice gate.

WILDWOOD LAKE

APPENDIX A
PERIODIC INSPECTION CHECKLIST

WILDWOOD LAKE

PERIODIC INSPECTION

PARTY ORGANIZATION

PROJECT Widwood Lake

DATE NOV 27, 1978

Note Available construction drawings
are included in Appendix B
of this report

TIME 12:00

WEATHER cloudy snow flurries

W.S. ELEV. 3077 2944

Benchmark E1 3077 at
spillway crest - based on 1959 drawings

INSPECTION:

- 1. E Greco 6. L. Branagan
- 2. S Pierce 7. _____
- 3. E Grecco 8. _____
- 4. Lord 9. _____
- 5. D Cole 10. _____

PROJECT FEATURE	INSPECTED BY	REMARKS
<u>Dam</u>	<u>E Greco / S Pierce</u>	
<u>spillway</u>	<u>L. Branagan</u>	

PERIODIC INSPECTION CHECK LIST

PROJECT Wildwood Lake DATE 11/27/78
 PROJECT FEATURE Dam NAME E Greco
 DISCIPLINE Geotechnical NAME S Pierce

Note: d/s = downstream, u/s = upstream

AREA EVALUATED	CONDITIONS
<u>DAM EMBANKMENT</u>	
Crest Elevation	315.1 to 316.5
Current Pool Elevation	307.7
Maximum Impoundment to Date	Unknown
Surface Cracks	n/a
Pavement Condition	grass cover, wheel marks indicate some vehicular traffic
Movement or Settlement of Crest	none apparent
Lateral Movement	none
Vertical Alignment	relatively straight
Horizontal Alignment	straight except at left abutment where embankment curves d/s
Location at Abutment and at Concrete Structures	r.e. into natural ground right: picnic area beyond abutment left: DPW Garage beyond abutment
Indications of Movement of Structural Items on Slopes	none visible
Trespassing on Slopes	footpath on d/s slope, left of spillway
Slumping or Erosion of Slopes or Abutments	u/s - 6' hole behind right wing of spillway, ~ 2' deep d/s - vehicle path on left embankment
Bank Slope Protection - Riprap retained	u/s - hand placed riprap, sparse planted on water's edge, covers riprap
Lateral Movement or Tracking at Riprap Line	none visible
Seepage, Impoundment or Downstream Channel	d/s, right on embankment - large wet area on slope to right of spillway left: seepage through rock core below left training wall of spillway
Sliding or Falls	none visible
Structural Drainage Features	none visible - underdrain system around beneath spillway apron and training walls - see drawings
Other	none
Other Structural Features	none
Concrete Slab constructed on d/s slope, left embankment	see A-2 p. 5

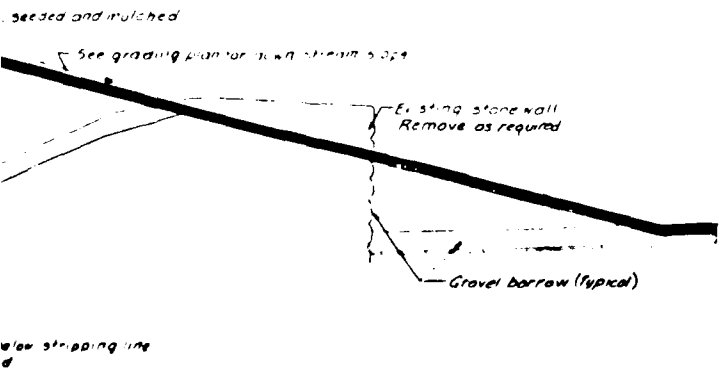
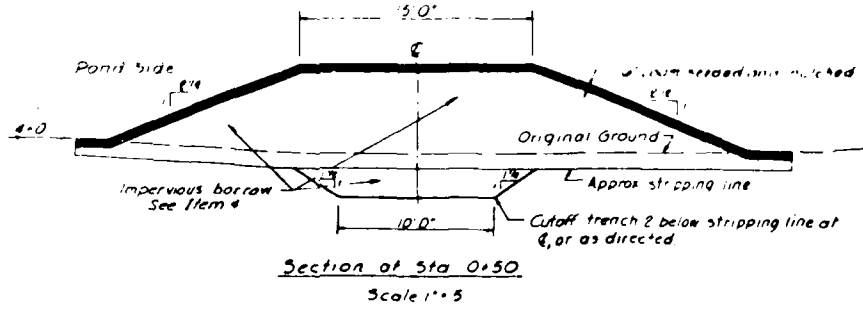
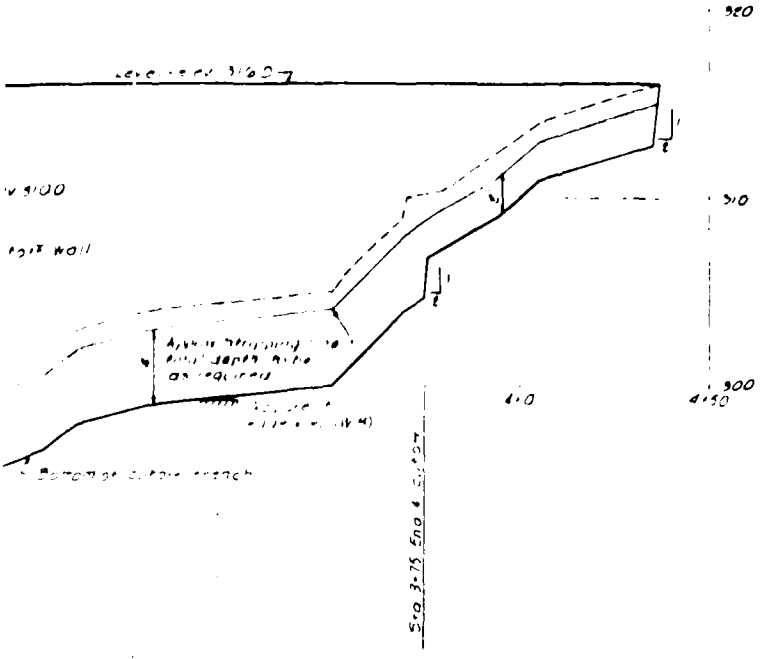

NOTE: DRAWING HAS BEEN REDUCED FOR THIS REPORT.

PROPOSED DAM REPAIRS JOURDAN POND WEST RIVER UPTON, MASS DEPARTMENT OF PUBLIC WORKS OF MASSACHUSETTS DIVISION OF WATERWAYS		
PROFILE AND TYPICAL SECTIONS		SHEET NO 5 OF 7
GREEN ENGINEERING AFFILIATES, INC. ENGINEERS BOSTON		
	DESIGNED: CAG	SCALE AS SHOWN
	DRAWN: CL A	DATE: SEPTEMBER 1968
	CHECKED: NEM	CONTRACT NO: 8048
THE PATENT ENGINEERS ALL RIGHTS RESERVED		

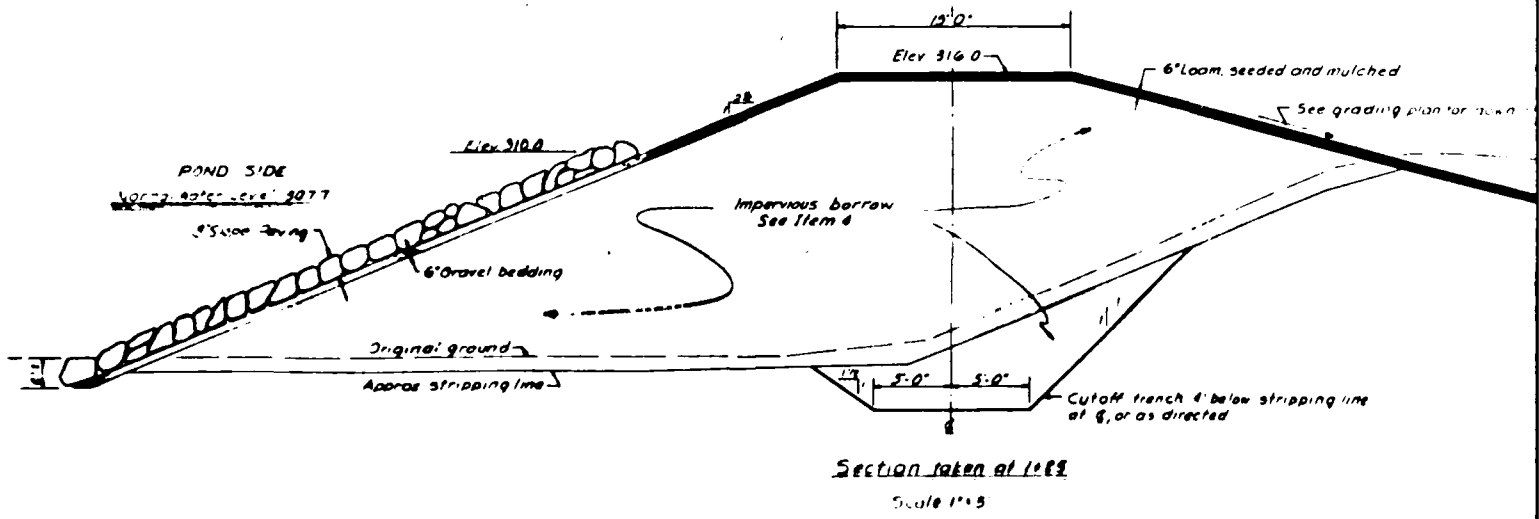
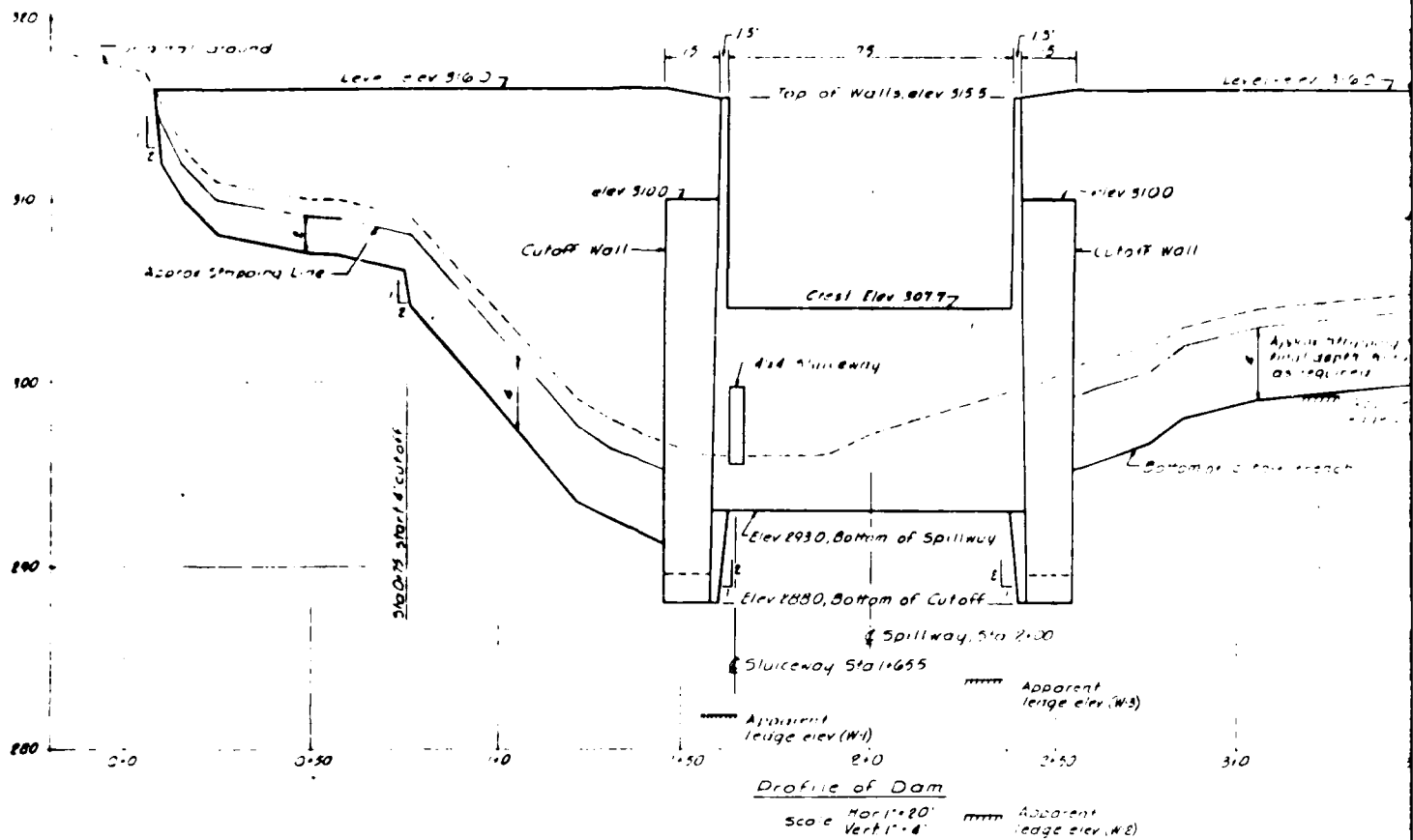

PRECEDING PAGE BLANK-NOT FILMED

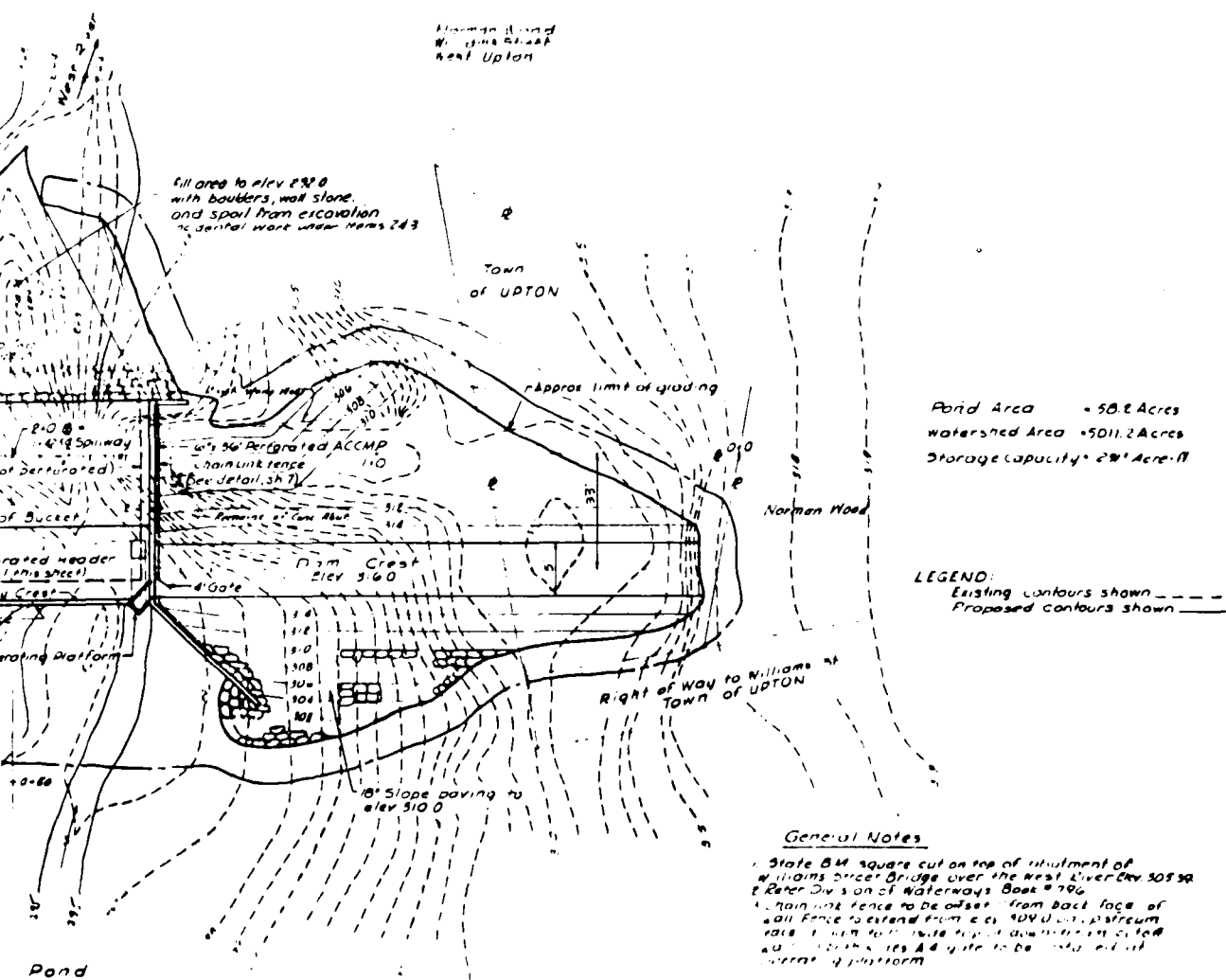

Pond Area = 58.2 Acres
 Watershed Area = 5011.2 Acres
 Storage Capacity = 29.1 Acre-ft

LEGEND:
 Existing contours shown - - - -
 Proposed contours shown - - - -

- General Notes
- State BM square cut on top of abutment of Williams Street Bridge over the West River City 30539 Refer Division of Waterways Book # 196
 - Chain link fence to be offset from back face of wall fence to extend from elev 304.0 to 310.0
 - 8\"/>

NOTE: DRAWING HAS BEEN REDUCED FOR THIS REPORT.

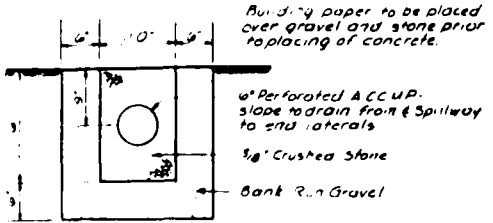

Detail of Drain Header and Trench
 No Scale

PROPOSED DAM REPAIRS JOURDAN POND WEST RIVER UPTON, MASS DEPARTMENT OF PUBLIC WORKS OF MASSACHUSETTS DIVISION OF WATERWAYS		
GENERAL PLAN		SHEET NO 2 OF 7
GREEN ENGINEERING AFFILIATES, INC. ENGINEERS BOSTON		
DESIGNED CAG DRAWN CLB CHECKED MCM	SCALE AS SHOWN DATE SEPTEMBER 1969 CONTRACT NO 2040	CHIEF WATERWAYS ENGINEER ACC 25022-B

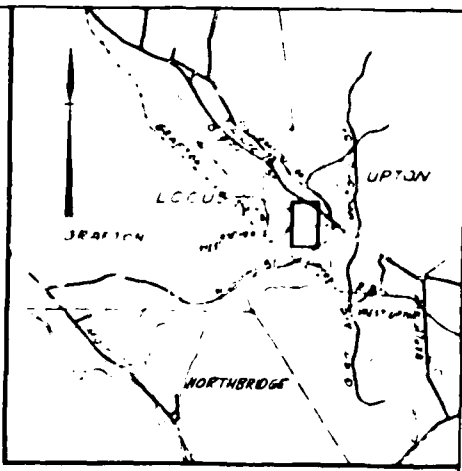
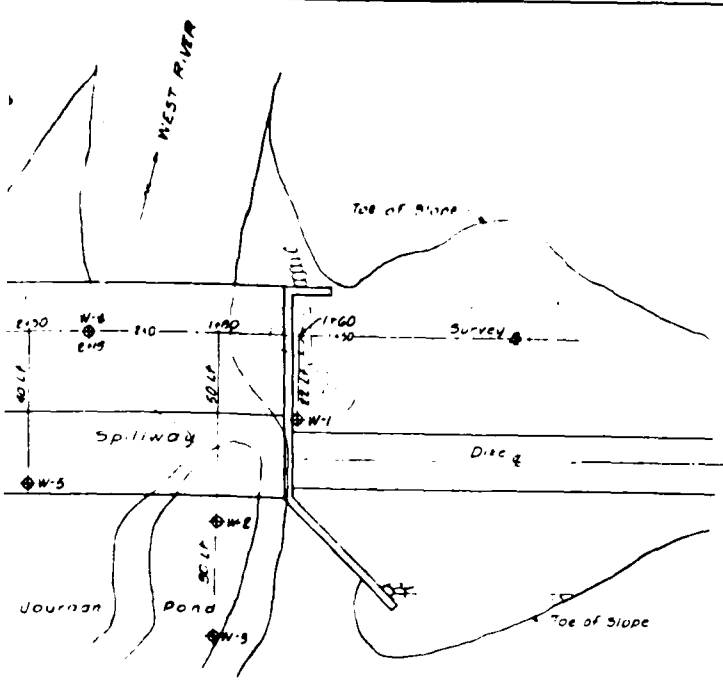

LOCATION PLAN
Scale 1"=100'

129 6-12-17 2-27
129 6-12-17

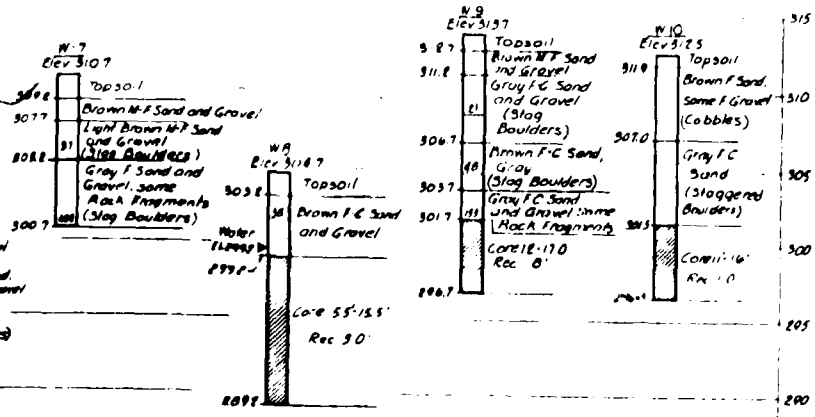

NOTE: DRAWING HAS BEEN REDUCED FOR THIS REPORT.

WORCESTER COUNTY COMMISSIONERS
 WORCESTER COUNTY ENGINEERING DEPARTMENT
 PLAN OF REPAIRS TO DAM
 JOURDAN POND WEST RIVER
 UPTON
 AS FILED AND APPROVED BY THE
 COUNTY COMMISSIONERS
 SCALES AS NOTED
 APPROVED June 23, 1900
 COUNTY ENGINEER
 ENGINEERS
 GREEN ENGINEERING APPLICATED, INC.
 DAM-NO-52-04

PROPOSED DAM REPAIRS
 JOURDAN POND WEST RIVER
 UPTON, MASS.
 DEPARTMENT OF PUBLIC WORKS OF MASSACHUSETTS
 DIVISION OF WATERWAYS

LOCATION PLANS AND BORING DATA

GREEN ENGINEERING APPLICATED, INC.
 ENGINEERS BOSTON
 MEMORIALS SCALE AS SHOWN
 DRAWN C.A.B. DATE SEPTEMBER 1900
 CHECKED A.M.H. CONTRACT NO. 2045
 DIVISION OF WATERWAYS ENGINEER
 REC 94030-2

WILDWOOD LAKE DAM FIGURE B-3

In conditions of
 nature of material
 on 1"=10' samples produced

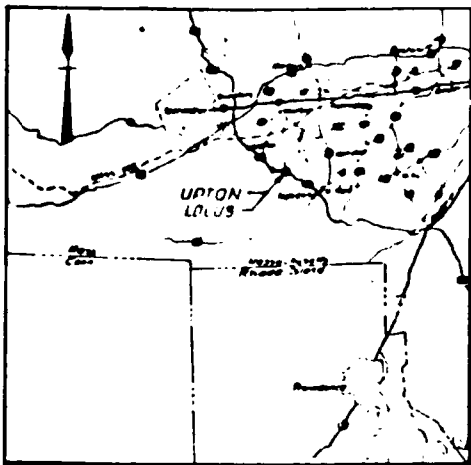

AREA PLAN
Scale 1" = 87M

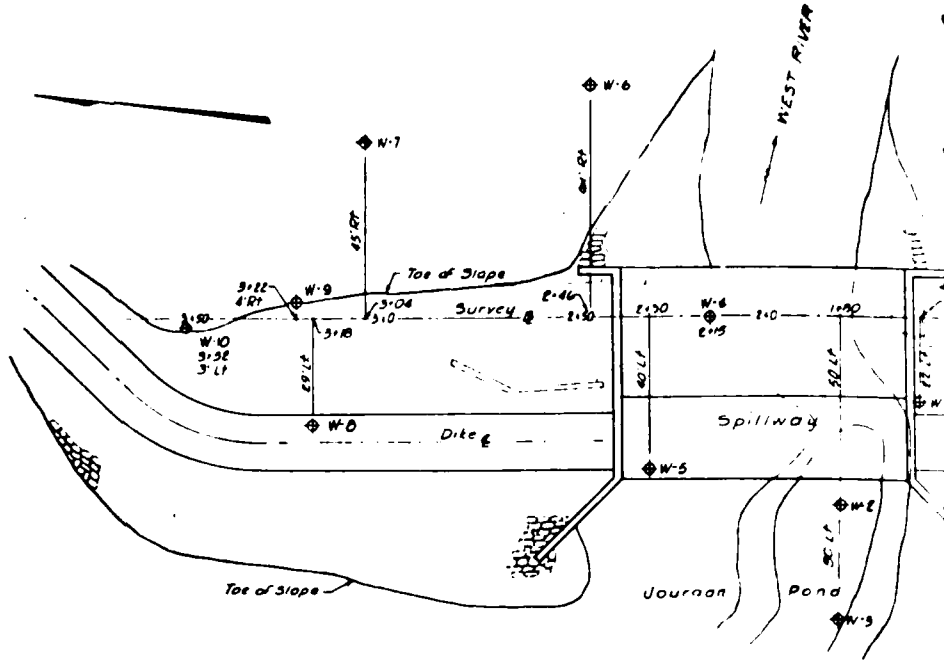

Boring Location Plan
Scale 1" = 100'

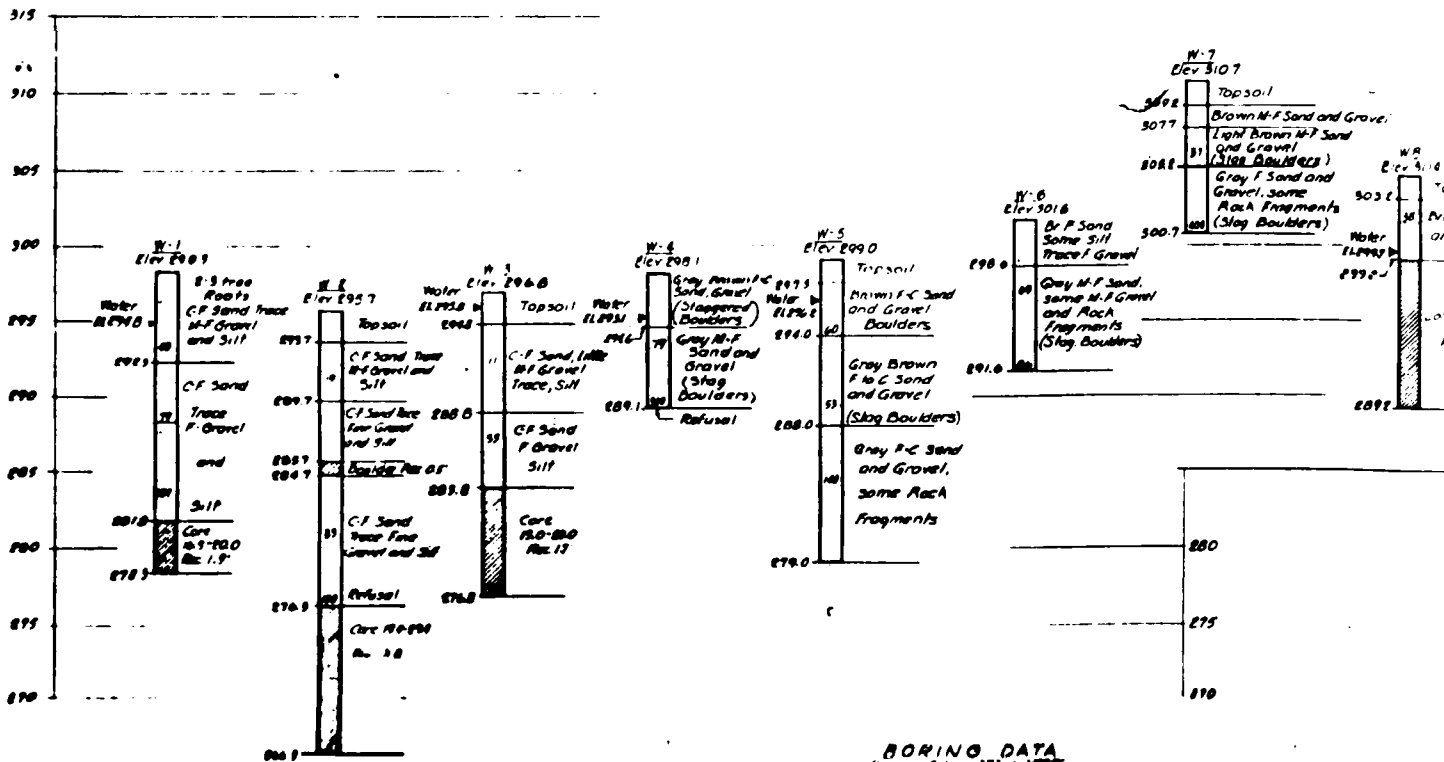

BORING DATA

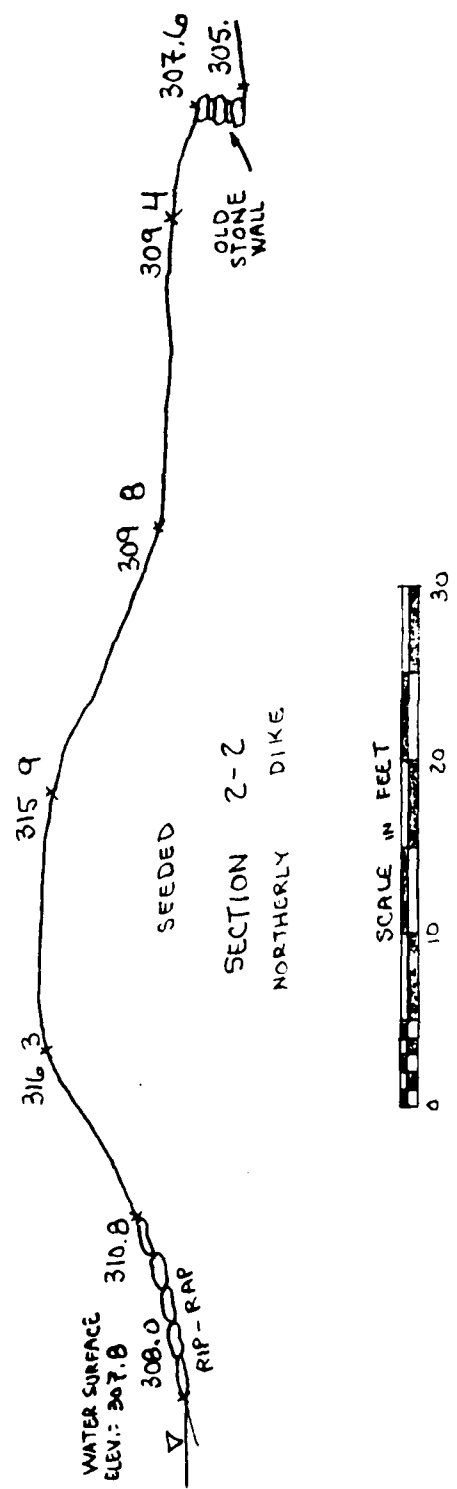
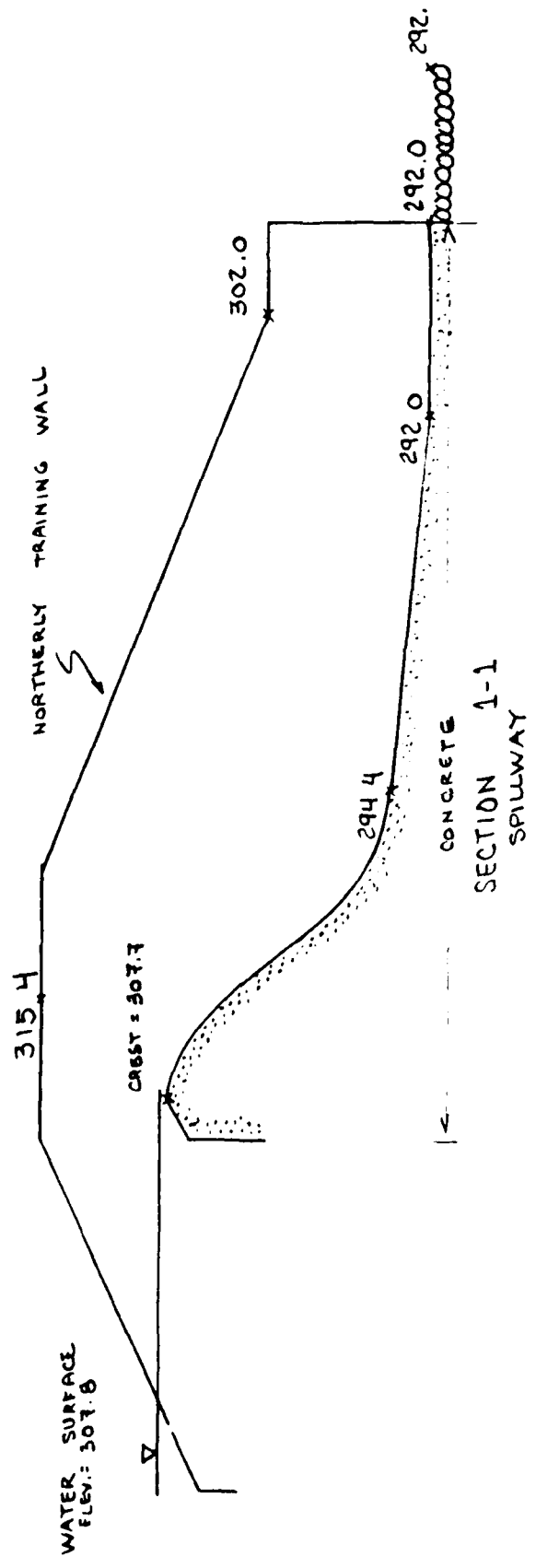

Notes
 1. Borings taken for purpose of design and show conditions at boring points only, but do not necessarily show nature of material to be encountered during construction.
 2. Figures in columns indicate blows per foot on 140 lb sampler produced by 30" fall of 140 lb hammer.



METCALF & EDDY, INC.

METCALF & EDDY, INC. ENGINEERS BOSTON, MASS.	U.S. ARMY ENGINEER DIV. NEW ENGLAND CORPS OF ENGINEERS WALTHAM, MA.
NATIONAL PROGRAM OF INSPECTION OF NON-FED. DAMS	
WILDWOOD LAKE DAM	
FIGURE B-2 SECTIONS THROUGH DAM	
TRIBUTARY BLACKSTONE RIVER	MASSACHUSETTS
SCALE: 1" = 10'	DATE: JANUARY, 1979

NOTES:

1. ELEVATIONS SHOWN ARE REFERENCED TO CREST ELEVATION 307.7 (MSL) AS SHOWN ON WORCESTER COUNTY PONS OF DAM REPAIRS - JOURDAN POND - WEST RIVER, JUNE 23, 1960
2. INFORMATION SHOWN BASED ON FIELD SURVEY OF NOVEMBER 27 1978 AND AFOREMENTIONED DAM REPAIR PLANS
3.  DENOTES SEEPAGE
4.  #2 INDICATES LOCATION AND DIRECTION OF VIEW FOR PHOTOGRAPHS
5. SEE FIGURE B-2 SECTIONS THROUGH DAM

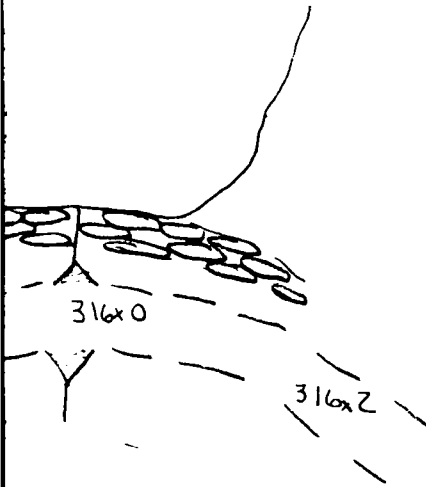

STONE WALL

317x0

METCALF & EDDY, INC. ENGINEERS ROCTON, MA.	U.S. ARMY ENGINEER DIV. NEW ENGLAND CORPS OF ENGINEERS WALTHAM, MA.
NATIONAL PROGRAM OF INSPECTION OF NON-FED. DAMS	
WILDWOOD LAKE DAM	
FIGURE B-1 PLAN OF DAM	
TRIBUTARY BLACKSTONE RIVER	MASSACHUSETTS
SCALE: 1" = 40'	DATE: JANUARY, 1979

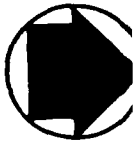

WILDWOOD LAKE

WATER SURFACE ELEV. = 307.8

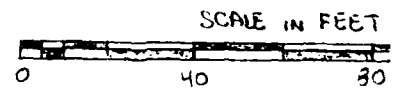
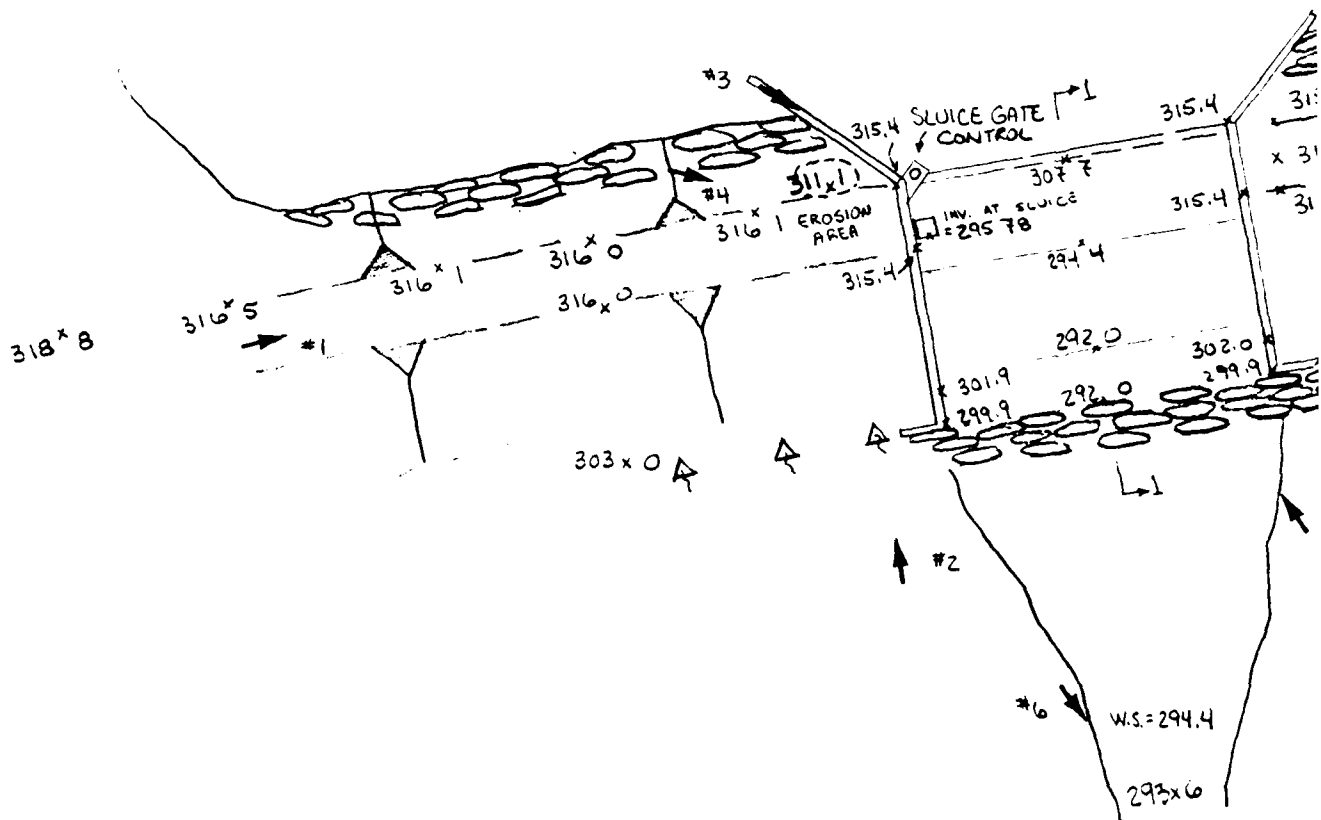

METCALF & EDDY, INC.

APPENDIX B
PLANS OF DAM AND PREVIOUS
INSPECTION REPORTS

	<u>Page</u>
Figure B-1. Plan of Dam	B-1
Figure B-2. Sections through Dam	B-2
Figures B-3 through B-9, Design Drawings by Green Engineering Affiliates, Inc., dated September, 1959	
Location Plans and Boring Data	B-3
General Plan	B-4
Profile and Typical Sections	B-5
Spillway Plan and Profile	B-6
Upstream Wingwall Details	B-7
Apron and Wall Details	B-8
Miscellaneous Details	B-9
Previous Inspections (Partial Listing)	B-10
Report of Study, Proposed Dam Repair, Jourdan Pond, West River, Upton, Massachusetts by Green Engineering Affiliates, Inc., August, 1958	B-12
Dam Inspection Report, Worcester County Engineering Department, 1963	B-21
Inspection Report by Massachusetts Department of Public Works, January, 1972	B-24

WILDWOOD LAKE

PERIODIC INSPECTION CHECK LIST

PROJECT Windwood Lake DATE 11/27/78
 PROJECT FEATURE Spillway NAME L. Branagan
 DISCIPLINE Hydraulic NAME E. Greco

AREA EVALUATED	CONDITION
<u>WEIR WORKS - SPILLWAY WEIR, APPROACH AND DISCHARGE CHANNELS</u>	
a. Approach Channel	No channel - approach is vertical concrete wall of weir. Concrete wing walls on each side of weir.
General Condition	/
Loose Rock Overhanging Channel	
Trees Overhanging Channel	
Floor of Approach Channel	
b. Weir and Training Walls	fair concrete walls over weir. Upraise force on wall exposed on each side except for concrete at base of training walls.
General Condition of Concrete	fair
Rust or Staining	fair
Spalling	fair
Any Visible Reinforcing	fair
Any Seepage or Efflorescence	fair
Train Holes	fair
c. Discharge Channel	fair
General Condition	fair
Loose Rock Overhanging Channel	fair
Trees Overhanging Channel	fair
Floor of Channel	fair
Other Obstructions	assumed fair of debris and material at base of weir. 150' dia. tree trunk in channel.

PERIODIC INSPECTION CHECK LIST

PROJECT Wildwood Lake
 PROJECT FEATURE Outlet Works
 DISCIPLINE Geotechnical

DATE 11-27-78
 NAME E Greco
 NAME S. Pierce

AREA EVALUATED	CONDITION
<u>OUTLET WORKS - OUTLET STRUCTURE AND OUTLET CHANNEL</u>	
General Condition of Concrete	Outlet opens at dis face of gate next to right training wall in good condition
Rust or Staining	none visible
Spalling	none
Erosion or Cavitation	none
Visible Reinforcing	none
Any Seepage or Efflorescence	none
Condition at Joints	-
Crack Holes	-
Channel	Discharge from outlet enters into stream channel below spillway
Loose Rock or Trees Overhanging Channel	large boulders placed on both ends for erosion protection, some small trees, fence on secondary channel
Condition of Discharge Channel	fair. Channel is about 1/5 width of discharge area immediately lower reach of spillway

PERIODIC INSPECTION CHECK LIST

PROJECT Wildwood Lake DATE 11-27-78
 PROJECT FEATURE Outlet Works NAME E Greco
 DISCIPLINE Geotechnical NAME S Perce

AREA EVALUATED	CONDITION
<u>OUTLET WORKS - INTAKE CHANNEL AND INTAKE STRUCTURE</u>	
1. Approach Channel	/
Slope Conditions	
Bottom Conditions	
Rock Slides or Falls	
Log Boom	
Debris	
Condition of Concrete Lining	
Drains or Weep Holes	Hard-operated sluice gate operation * see drawing for details
2. Intake Structure	
Condition of Concrete	
Stop Logs and Slots	-

* Rating Chart 28270-2 Ser # 5-5012-A

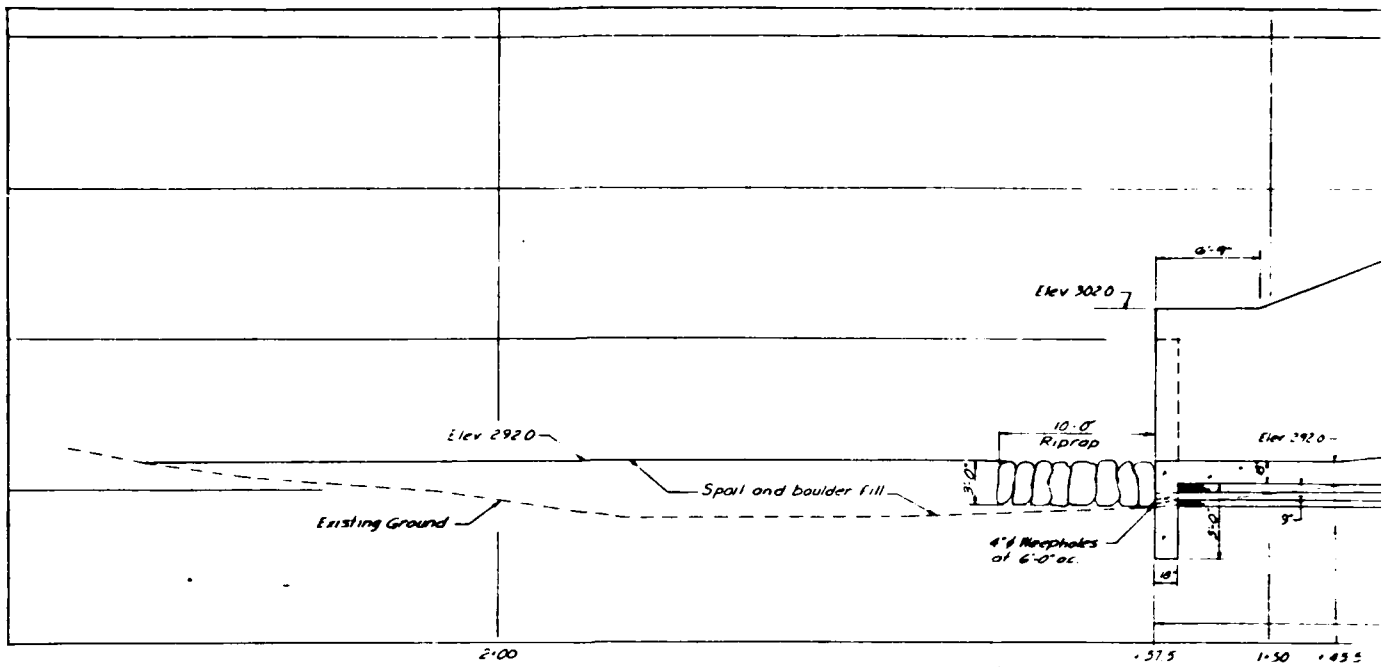

PROFILE & PROPOSED SPILLWAY

Scale: 1/4" = 1'-0"

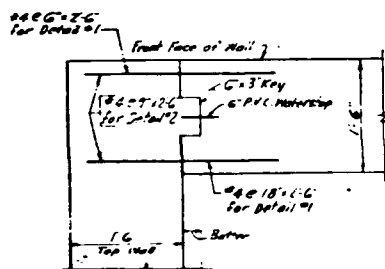

DETAIL #1
Scale: 1" = 1'-0"

NOTE:
For sections see
Sheet 6

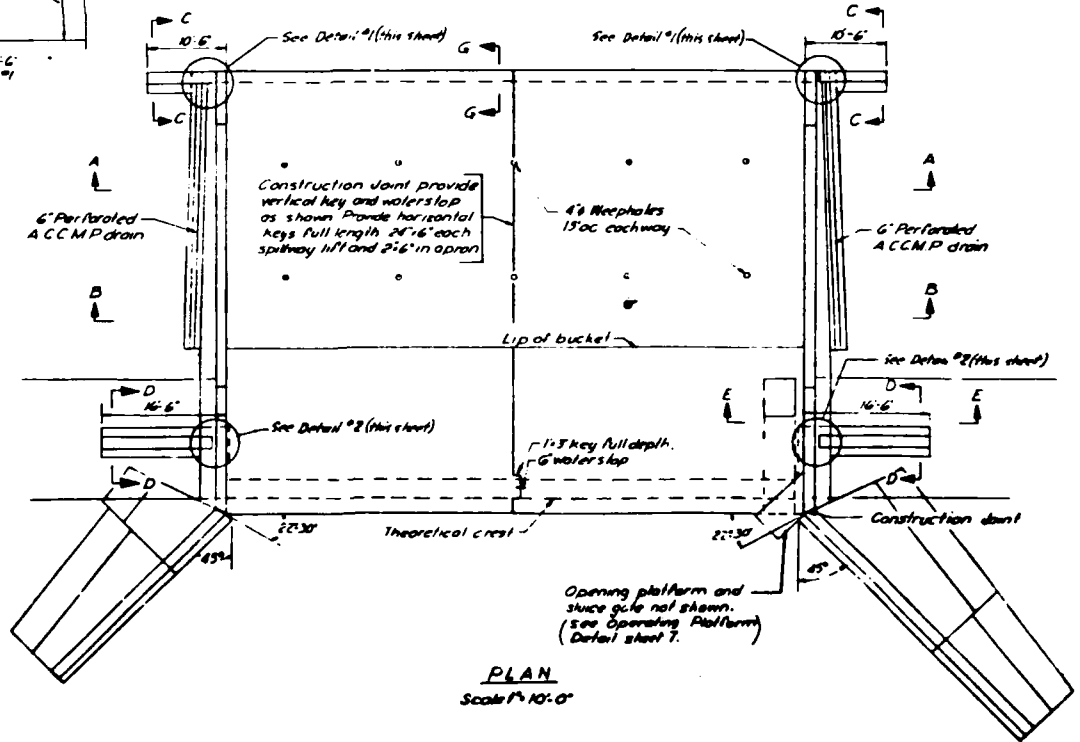

PLAN
Scale: 1/4" = 1'-0"

PRECEDING PAGE BLANK-NOT FILMED

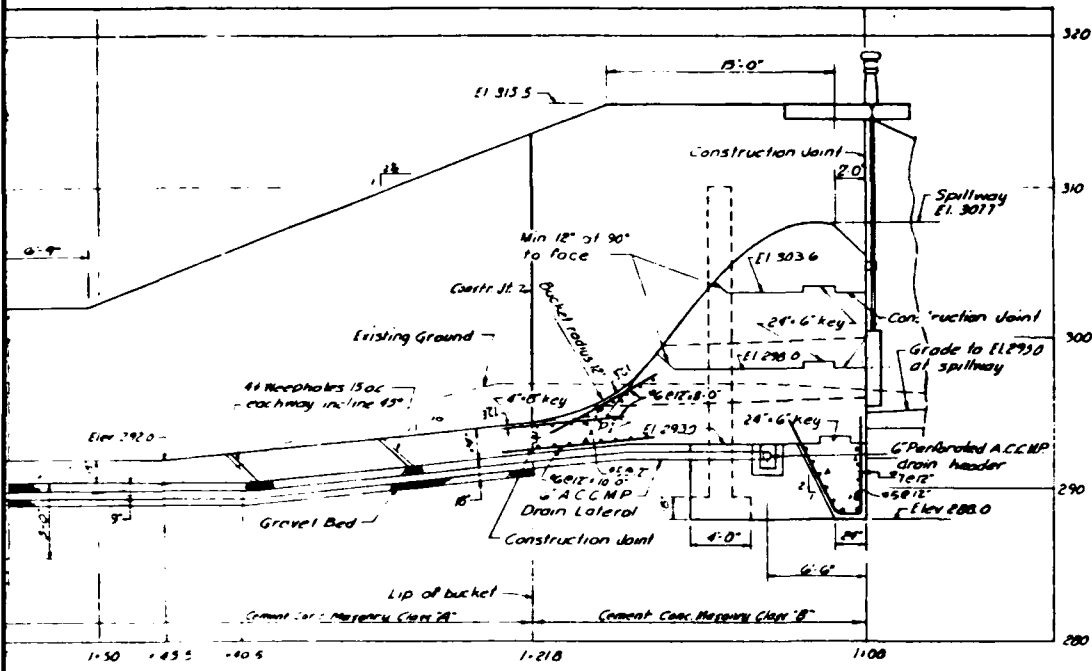

PROPOSED SPILLWAY

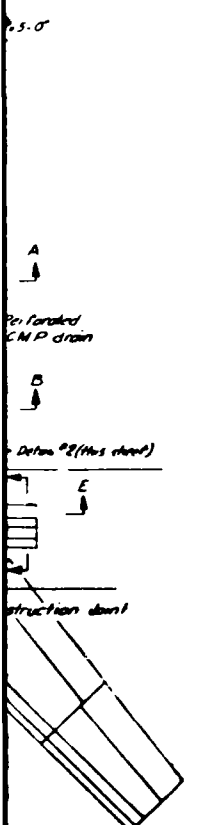

CO-ORDINATES OF SPILLWAY	
STATION	ELEVATION
1+02.0	307.46
1+02.6	307.64
1+03.1	307.70
1+03.7	307.67
1+04.2	307.57
1+05.3	307.20
1+06.4	306.64
1+07.5	305.87
1+08.6	304.97
1+09.7	303.85
1+11.4	301.93
1+11.5	301.70
SLOPE 9 HORIZONTAL TO 12 VERTICAL TO BUCKET	
P.I. OF BUCKET	
1+16.60	294.89

STRUCTURAL NOTES:

1. Chamfer on all exposed corners.
2. Cement concrete masonry class "B" - 3000 p.s.i. compressive strength.
3. Cement concrete masonry class "B" - 2500 p.s.i. compressive strength.
4. Reinforcement Steel - 20,000 p.s.i. used in design.
5. Minimum bar laps at splices - 24 dia. or as shown.
6. Provide 2" clear cover over reinforcing at formed surfaces.
7. 3" of surfaces poured against earth, unless otherwise noted.

PROPOSED DAM REPAIRS JOURDAN POND WEST RIVER UPTON, MASS. DEPARTMENT OF PUBLIC WORKS OF MASSACHUSETTS DIVISION OF WATERWAYS		
SPILLWAY PLAN AND PROFILE		SHEET NO. 4 OF 7
GREEN ENGINEERING AFFILIATES, INC. ENGINEERS BOSTON		
DESIGNED CAS DRAWN AJP CHECKED AB	SCALE: AS SHOWN DATE: SEPTEMBER 1960 CONTRACT NO. E040	CWP WATERWAYS ENGINEER S.C.C. 04035-9

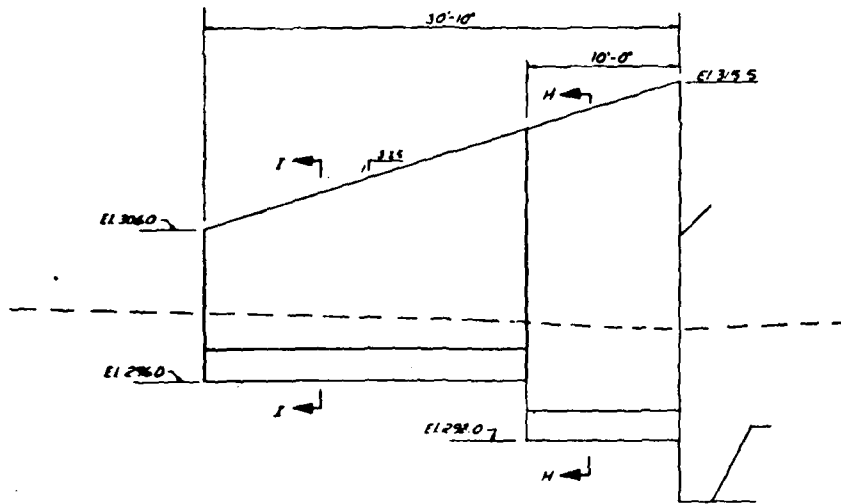

SLICE
17x. 896.0
EI 291

ELEVATION OF LEFT UPSTREAM WINGWALL
Scale 1" = 5'-0"

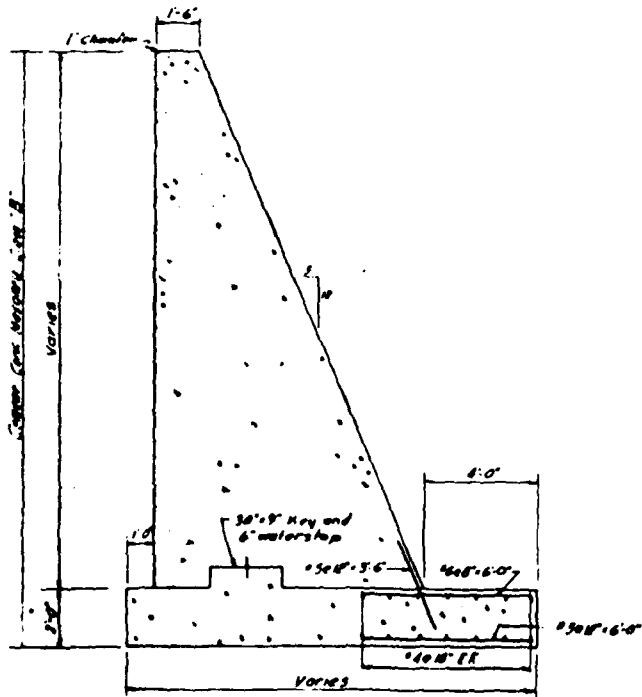

SECTION N-N
Scale 1/8" = 1'-0"

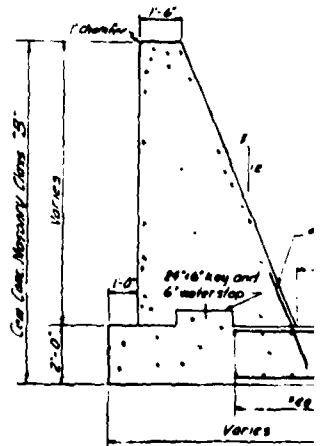

SECTION I-I
Scale 1/8" = 1'-0"

PRECEDING PAGE BLANK-NOT FILMED

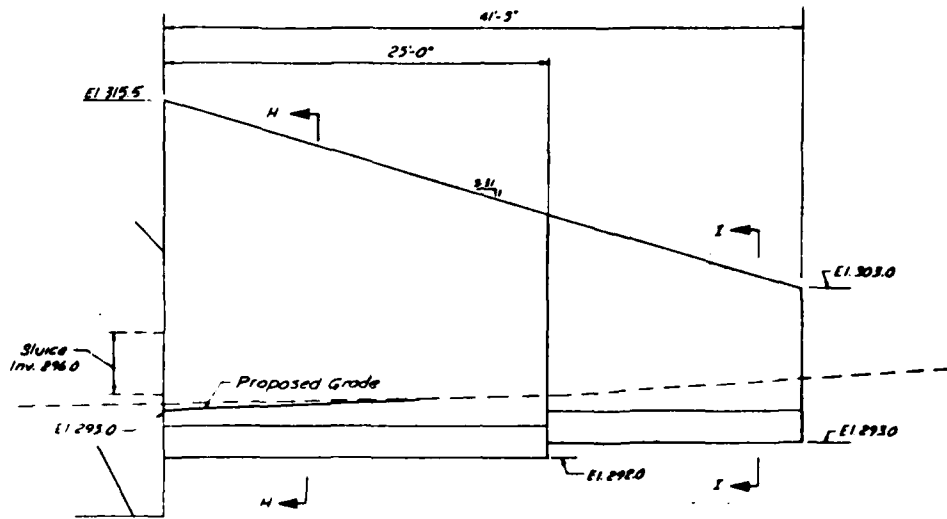

ELEVATION OF RIGHT UPSTREAM WINGWALL
Scale 1" = 5'-0"

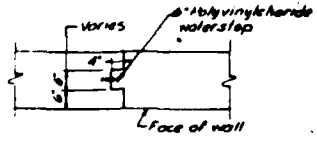

Waterstop at Joints
CONSTRUCTION JOINT DETAIL
Scale 1/2" = 1'-0"

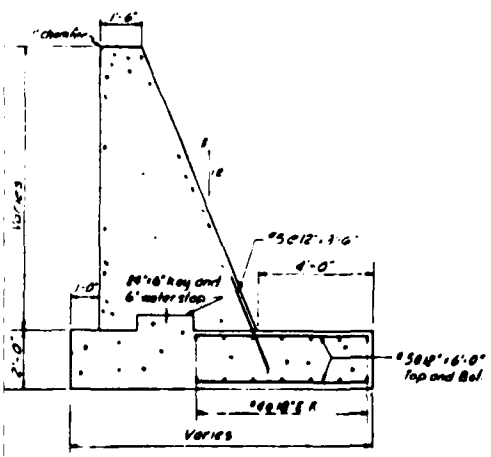

SECTION I-I
Scale 1/2" = 1'-0"

NOTE: DRAWING HAS BEEN REDUCED FOR THIS REPORT.

PROPOSED DAM REPAIRS JOURDAN POND WEST RIVER UPTON, MASS. DEPARTMENT OF PUBLIC WORKS OF MASSACHUSETTS DIVISION OF WATERWAYS			
UPSTREAM WINGWALL DETAILS			SHEET NO 6 OF 7
GREEN ENGINEERING AFFILIATES INC ENGINEERS		BOSTON	
	DESIGNED: CAG	SCALE AS SHOWN	CHIEF WATERWAYS ENGINEER ACC 04030-E
	DRAWN: ALP	DATE: SEPTEMBER 1999	
	CHECKED: ADM	CONTRACT NO 2049	

WILDWOOD LAKE DAM

DAM - NO - 52-04

FIGURE B-7

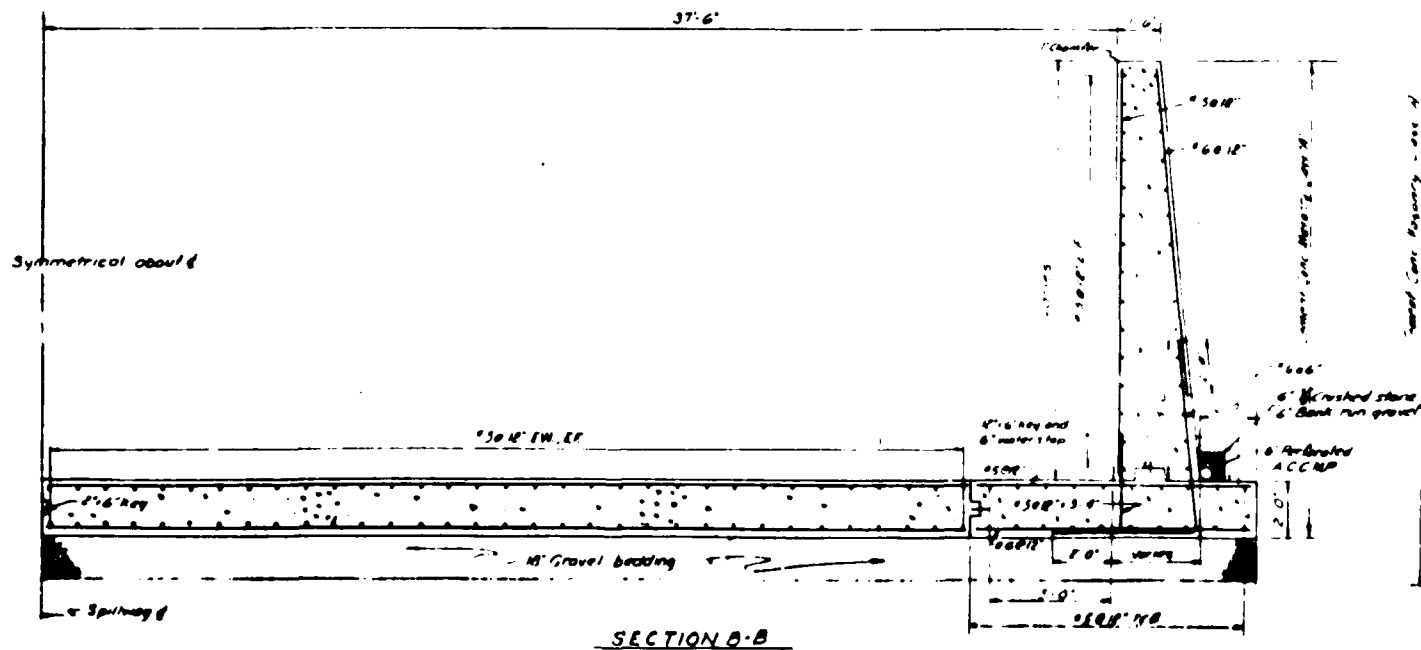
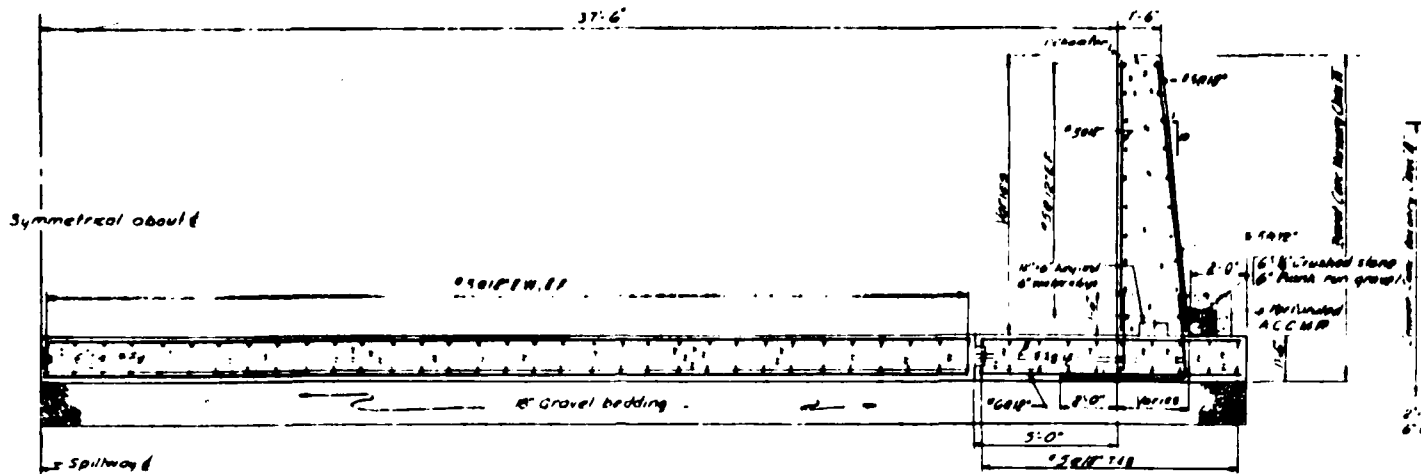

PRECEDING PAGE BLANK-NOT FILLED

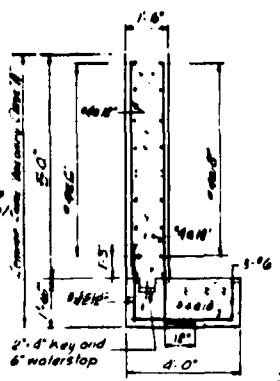
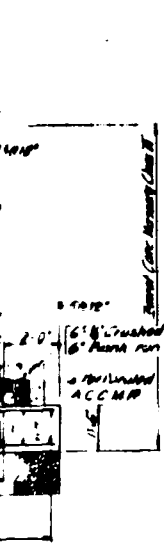

SECTION C-C

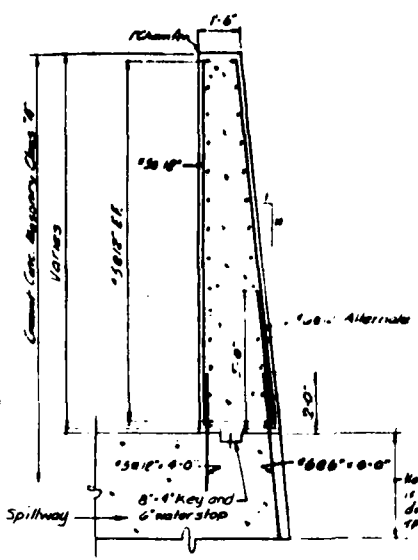

SECTION E-E

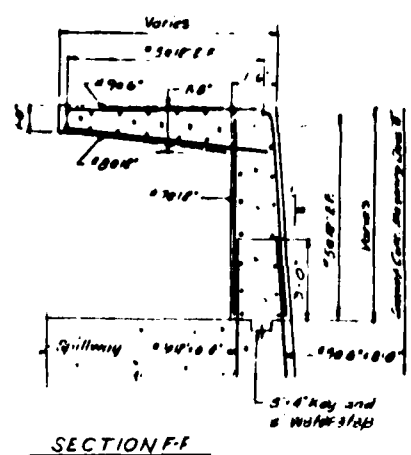

SECTION F-F

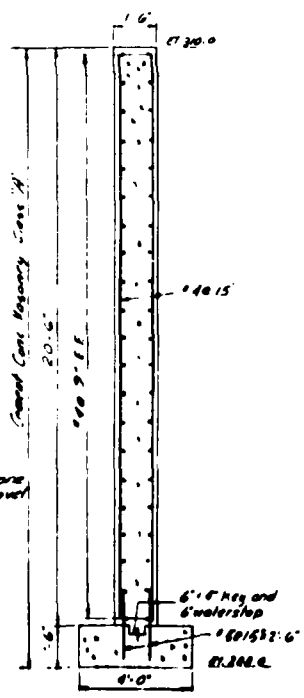

SECTION D-D

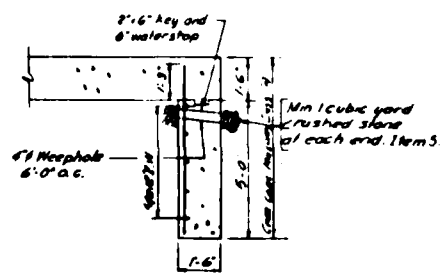

SECTION G-G

NOTE: DRAWING HAS BEEN REDUCED FOR THIS REPORT.

PROPOSED DAM REPAIRS JOURDAN POND WEST RIVER UPTON, MASS. DEPARTMENT OF PUBLIC WORKS OF MASSACHUSETTS DIVISION OF WATERWAYS		
APRON AND WALL DETAILS		SHEET NO 6 OF 7
GREEN ENGINEERING AFFILIATES, INC. ENGINEERS BOSTON		
DESIGNED CAG DRAWN ACP CHECKED MCM	SCALE: 3/8" = 1'-0" DATE: SEPTEMBER 1988 CONTRACT NO 8040	CHIEF WATERWAYS ENGINEER ADC 0-000-7

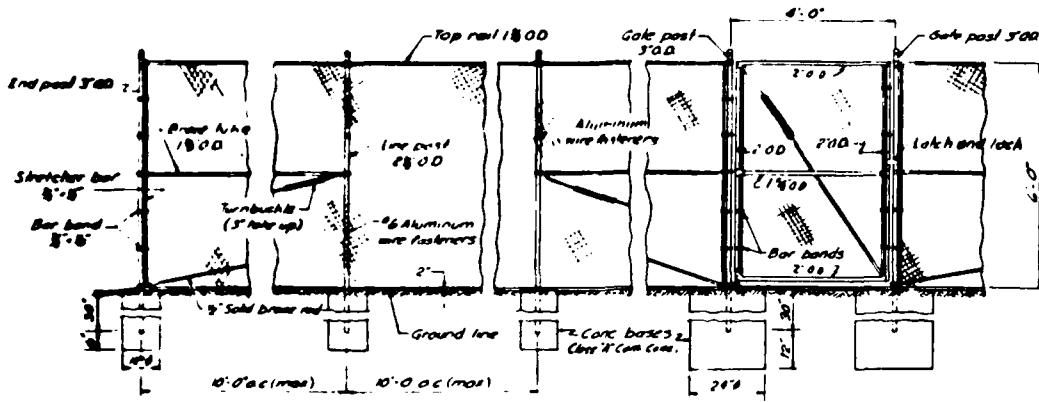

CHAIN LINK FABRIC FENCE

No Scale

NOTES:

- 1 Chain link fabric to be 2' mesh, #6 galvanized copper bearing steel wire.
- 2 Top and bottom selvage to have knuckled finish.
- 3 All posts, rails, and braces to be copper bearing steel pipe, galvanized inside and outside. All fittings to be galvanized.
- 4 Grade of fence to be parallel to top of dam.

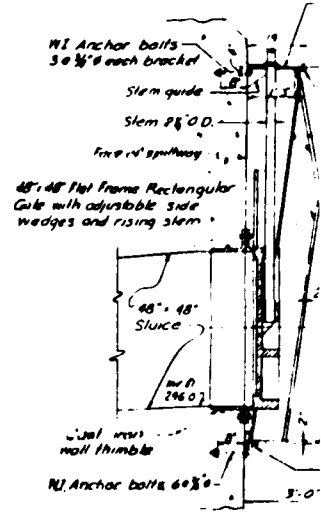

SECTION

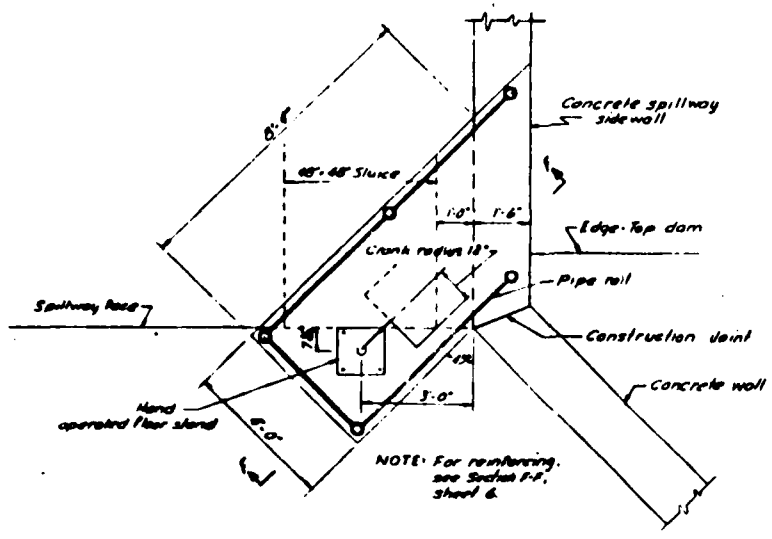

OPERATING PLATFORM DETAIL
Scale 1/4"=1'-0"

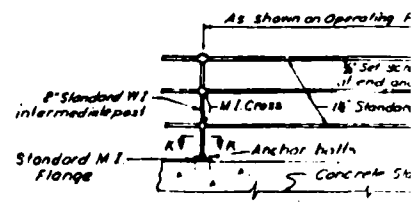

ELEVATION

- NOTES:**
- 1 Anchor to 6 mm of
 - 2 All pipe to bear Man.
 - 3 For point, see spec

IRON

PRECEDING PAGE BLANK-NOT FILMED

TOWN OR CITY	Upton	DEGREE NO.	Maplan	PLAN NO.	1936 Flood	DAM NO.	58-04
LOCATION	West River - W. Upton - washed out by 1936 Flood	DESCRIPTION OF DAM	DESCRIPTION OF RESERVOIR & WATERSHED	PLAN NO.	1936 Flood	DAM NO.	58-04
Type	Earth - dry stone walls	Length	Name of Main Stream	PLAN NO.	1936 Flood	DAM NO.	58-04
Length	Heavy Stone Concrete spillway	Height	" " any other Streams	PLAN NO.	1936 Flood	DAM NO.	58-04
Height	150' - at waste Gate 28.0	Thickness top	Length of Watershed	PLAN NO.	1936 Flood	DAM NO.	58-04
Thickness bottom	160'	Downstream Slope	Width " "	PLAN NO.	1936 Flood	DAM NO.	58-04
Upstream	12:1 gravel	Upstream	Is Watershed Cultivated	PLAN NO.	1936 Flood	DAM NO.	58-04
Length of Spillway	10.5' - Depth 4.7' - Top Crest El. 3090	Length of Spillway	Percent In Forests	PLAN NO.	1936 Flood	DAM NO.	58-04
Site of Gates	18' x 12' - also 2.43 x 2.6	Location of Gates	Steepness of Slope	PLAN NO.	1936 Flood	DAM NO.	58-04
Location of Gates	20' East of spillway	Flashboards used	Kind of Soil	PLAN NO.	1936 Flood	DAM NO.	58-04
Flashboards used	Yes	Width Flashboards or Gates	No. of Acres in Watershed	PLAN NO.	1936 Flood	DAM NO.	58-04
Width Flashboards or Gates	El. 07.3	Dam designed by	Length of Reservoir	PLAN NO.	1936 Flood	DAM NO.	58-04
Dam designed by	" reconstructed by up & downstream concrete walls	Year constructed	Width " "	PLAN NO.	1936 Flood	DAM NO.	58-04
Year constructed	spillway rebuilt 1912	GENERAL REMARKS	Max Flow Cu. Ft per Sec.	PLAN NO.	1936 Flood	DAM NO.	58-04
Owner	Smith Mills Co. { Dr. C.E. Smith	GENERAL REMARKS	Head of Flashboards - Low Water	PLAN NO.	1936 Flood	DAM NO.	58-04
"	1928 - Angelo Mazzi - West Upton	GENERAL REMARKS	" " " - High "	PLAN NO.	1936 Flood	DAM NO.	58-04
"	1937 - Wildwood Lake - Associates.	GENERAL REMARKS	Inspected: May 29, 1928 - F. E. Perry	PLAN NO.	1936 Flood	DAM NO.	58-04
Inspected	April 22, 1925 - L. O. Marden.	GENERAL REMARKS	June 2 " L.O.M.	PLAN NO.	1936 Flood	DAM NO.	58-04
"	Nov. 11, 1926 "	GENERAL REMARKS	" 12, " "	PLAN NO.	1936 Flood	DAM NO.	58-04
"	Sept. 7, 1927 - L. O. M. Goodale.	GENERAL REMARKS	Aug. 10, " L.O.M. - Goodale - Cooke	PLAN NO.	1936 Flood	DAM NO.	58-04
"	Jan. 18, 1928 " Ins. May 24 '28	GENERAL REMARKS	" 11, " " - H. Johnson	PLAN NO.	1936 Flood	DAM NO.	58-04
with A. Mazzi	May 26 " F. E. Perry	GENERAL REMARKS	" 14, " " " F. E. P.	PLAN NO.	1936 Flood	DAM NO.	58-04
"	" 28 " " - L.O.M.	GENERAL REMARKS	Oct. 18, " " S. H. Pitcher	PLAN NO.	1936 Flood	DAM NO.	58-04
Part Survey	7-26-28 Marden - Johnson - BK 3616 P. 25	GENERAL REMARKS	Feb. 7, 1929 - " C. M. Brough	PLAN NO.	1936 Flood	DAM NO.	58-04

LETTERHEAD

Date

The Commonwealth of Massachusetts
Department of Public Works
Division of Waterways
100 Nashua Street
Boston, Massachusetts

Attention: Mr. R. B. MacKinnon, Chief Waterways Engineer

Gentlemen:

Subject: Report of Study
Proposed Dam Repair
Jourdan Pond
West River, Upton

We submit the following report of study and preliminary design for your review in accordance with our contract.

It should be noted that we have not yet completed our subsurface investigations; however, our soils consultant has examined the site and no foundation difficulties are anticipated.

We would like to point out that the dam above Jourdan Pond, at Silver Lake, has inadequate spillway capacity, and it could be a hazard to the proposed work under design conditions.

We are proceeding with subsurface investigations and will commence contract plans as soon as we hear from you as to the layout selected.

Very truly yours,

GREEN ENGINEERING AFFILIATES, INC.

R. E. Crawford
Vice President

REC:mo'd
Enclosures

B-12

WILDWOOD LAKE DAM

REPORT OF STUDY

PROPOSED DAM REPAIR

JOURDAN POND

WEST RIVER

UPTON, MASSACHUSETTS

Prepared For

DEPARTMENT OF PUBLIC WORKS OF MASSACHUSETTS

DIVISION OF WATERWAYS

AUGUST 1958

By: Green Engineering Affiliates, Inc.
Engineers Boston

WILLOWOOD LAKE DAM

TABLE OF CONTENTS

	<u>Pages</u>
<u>Text of Report</u>	1-6
General	1
Hydrology	2-3
Pond Levels	4
Layout A	4
Layout B	5-6
Recommendations	6
 Appendix	
Runoff Computations	1-3
Hydrograph	4-5
Routing computations	6-8
Sketch of Silver Lake Spillway	9
Layout "A"	
Plan	
Profile of Spillway	
Dike Section	
Estimate	
Layout "B"	
Plan	
Spillway Section	
Dike Section	
Estimate	

WILDWOOD LAKE DAM

REPORT OF STUDY
PROPOSED DAM STUDY
JOURDAN POND, UPTON

General

Jourdan Pond, or Lake Wildwood, as it was sometimes called, was impounded by a stone masonry and earth dam constructed about 1851 as a power reservoir. The dam was operated and maintained by various industrial interests until 1934, when the pond and dam became the property of the Lake Wildwood Improvement Association, an organization formed locally. At and before this time the pond was much used for recreation, and supported a boat house and a dance pavilion, as well as cottages and fishing. It covered some 50 acres and extended over half a mile toward the Grafton line.

On March 12, 1936 at about 6:45 p.m. the dam failed, apparently due to overtopping. The property later passed to Mr. Grebenstien, who sold it to the Town. At present, the pond has been empty some 22 years, and it is heavily grown to brush and trees. This study is limited to the restoration of the dam itself, as provided in the act of the General Court providing for reconstruction. Clearing and preferably stripping of the pond area will be necessary before filling; this is the responsibility of the Town of Upton.

WILLOW LAKE DAM

APPENDIX D
HYDROLOGIC AND HYDRAULIC
COMPUTATIONS

	<u>Page</u>
Figure D-1. Drainage Area Map	D-1
Computations	D-2

WILDWOOD LAKE



NO. 5 OGEE WEIR AND RIGHT TRAINING WALL



NO. 6 DOWNSTREAM VIEW OF DISCHARGE CHANNEL

WILDWOOD LAKE DAM



NO. 3 UPSTREAM VIEW OF SPILLWAY AND GATE MECHANISM



NO. 4 EROSION ON UPSTREAM SLOPE

WILDWOOD LAKE DAM



NO. 1 CREST OF DAM FROM RIGHT ABUTMENT



**NO. 2 DOWNSTREAM FACE OF DAM, TO RIGHT
OF SPILLWAY (SEEPAGE AREA)**

WILDWOOD LAKE DAM

APPENDIX C
PHOTOGRAPHS

WILDWOOD LAKE

(11-H.)

INSPECTION REPORT & DATA FOR DAMS

Owner: TOWN OF UPTON SELECTMAN
His Address:
Function of Dam: STORAGE

Dam No. 303-04
Town: UPTON
Stream: WEST RIVER
Pond: WILDWOOD LAKE
Date: 1/14/72
By:

Location & Access: REAR OF DFW MAINTENANCE
PIT ON RTE #140 IN UPTON.
USGS Quad. Grafton Lat. 42° 10' 25" Long. 71° 37' 50"
Drain. Ar.: 797 Sq. Mi.; Ponds: ac.; Res. @ dam:
Character of D.A.:

CONDITION RATING
Structural: GOOD
Hydraulic: 75' x 75'
General: GOOD
PRIORITY: NONE

Estimated Discharge:
Capacity:

General Description of Dam and Discharge Control:

RC OGEE SPILLWAY W/ 1-4' x 4' GATE
EARTH DAM ON BOTH SIDES OF SPILLWAY

Sketch (Not to Scale):

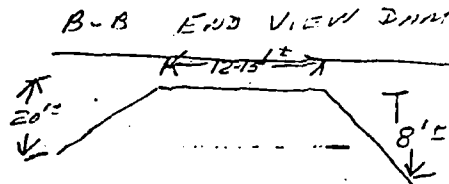
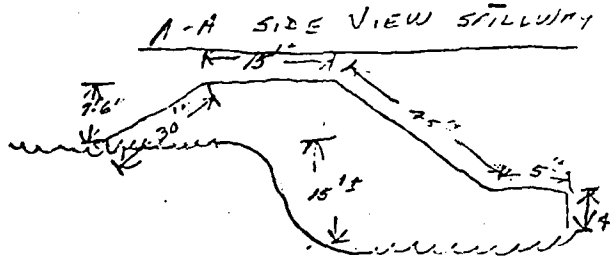
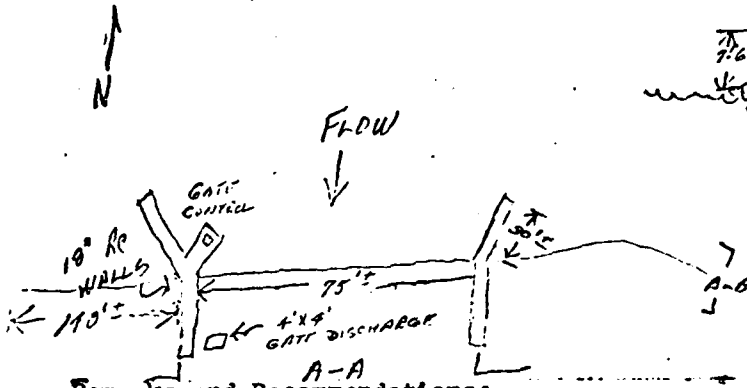

Remarks and Recommendations:

Date 1/14/72

By JFP
RZ

Comment

3-14-303-04
Dam No. 52-04

Hudson Pond - (Continued)

1963

The foundation of this trench, on the northerly side, is on good hard pan - no dangerous water was encountered while excavating this trench. On the southerly side, the foundation is on gravel - this trench should be excavated deeper to reach suitable material. 2 inspectors are on the job at this time.

June 24. W.O. Bigden, Colahan, Tongas. The construction work is nearly completed. The contractor will try to complete the heavy work this week.

July 1. W.O. The spillway is completed - very good. The embankment is nearly seeded - very good. The gate is completed - very good - the gate is wide open. This gate will remain open until the pond area is cleared of all brush, trees, debris, etc.

(The contractor on this project was Abland's Boynton Construction Co.)

Lordan Pond

1963

Mar. 9 - WOL - Carpenters are working on the forms for the 2nd lift, at the southerly half of the spillway. The northerly half is completed.

Mar. 14 - WOL - No men working on this date. The concrete has been poured in the 2nd lift. The temporary rd. in the dam is very poor.

Mar. 19 - WOL, etc. Inspector & (MOPW-Waterways Dept) is checking work - workmen are finishing off the concrete that was poured this morning on the 3rd lift of the one curve in at the spillway - the curved crest is hand finished. The work will stop for 2 weeks or more, on account of the high water conditions. These forms were strained on 3/17.

Apr. 1 - WOL - No work is being done by the contractor

Apr. 5 - WOL - This project is still closed down (Apr 17 - see above) now.

Apr. 9 - WOL - MOPW-Waterways Div. District Inspector was checking work on

date. The southerly concrete cur wall has been poured. The carpenters are

May 8 - WOL - RSL - Carpenters are erecting forms for downstream apron - also

May 9 - WOL - Concrete is being poured at southerly 1/2 of dam apron. Inspection of work by Theo. Demesha. The concrete cut-off wall has been poured. The concrete is furnished by Varney Bros.

May 17 - WOL - The concrete is being poured at the wing wall on the southerly end of the spillway - the pour began at 11 am - the dist. spillway apron is completed, including the section beyond the cut-off or toe wall. The MOPW inspector is Mr. Marcucci.

June 4 - WOL - Carpenters on forms for final section of northerly abutment wall. To be poured later this week - 24 yds required. Shovel is clearing the last channel.

June 23 - WOL - The contractor will complete the concrete work in the southerly part of the dam. The cut-off wall on the northerly half of the spillway apron. The concrete is being poured around the wings, spillway, cut-off wall, apron, etc. A trench has also been dug in the dam. The concrete cur wall - for lift.

TOWN Upton DAM NO. 52-04
LOCATION above dam 52-04 STREAM West Pond
Sawden Pond

WORCESTER COUNTY ENGINEERING DEPARTMENT
WORCESTER, MASSACHUSETTS

DAM INSPECTION REPORT

Owned by Town of Upton Place Selectman Use Recreation and Storage Pond
Inspected by W.C. Date 1963
Type of Dam Earth and concrete Condition Very Good

SPILLWAY

Flashboards in Place _____ Recent Repairs _____
Condition _____
Repairs Needed _____

ABUTMENT

Recent Repairs _____
Condition _____
Repairs Needed _____

GATES

Recent Repairs _____
Condition _____
Repairs Needed _____

LEAKS

How Serious _____

DAMS: _____

County Engineer

WILDWOOD LAKE DAM

Layout "B" would benefit less from favorable earthwork prices, but would be more apt to attract low prices for concrete. With favorable bids, this scheme might be built for \$85,000 to \$90,000, but again we feel that our estimate (\$101,000) is better for use in financial planning.

Layout "B" has the disadvantages in price which result from placing the spillway in the center of the dikes, and there is a slight added risk of creep along the walls; hardly serious at these heads. Otherwise, this is a preferable scheme from many viewpoints; the longer spillway gives less rise at design conditions, and a less frequent rise above 310.40. The layout requires only releases for sloping on private lands, and could get underway more readily. Finally, stream diversion should be considerably simpler.

Recommendations

While Layout "A" is cheaper, and more pleasing from an engineering viewpoint, we feel that, if funds are available, Layout "B" is preferable.

considerably so. Since we do not know the source of the borrow for the dike, we have estimated a high figure for borrow, and arrived at a construction cost, without contingencies, of \$92,000. With local borrow and favorable bids on other items, this might be as low as \$75,000 to \$30,000, but the figure of \$92,000 is considered better for financing use.

This scheme has several disadvantages. The necessity for channel paving and a long approach wall reduces the advantage usually gained by placing the spillway in an abutment. The rise in the pond for design conditions is quite large. Administratively, the fact that this scheme would require acquisition in fee of private lands would be a handicap. During construction, stream diversion would be a problem, though not an insurmountable one.

Layout "B"

In view of the disadvantages of Layout "A," a second, less orthodox, layout was considered, using a 75' spillway in the center of the dike. This was estimated as costing \$101,000 to build, without contingencies, surprisingly close to the figure for Layout "A."

Sketches of this are appended as Layout "B." (It should be noted here that these sketches are for general layout only, and no attempt has been made to show details of exact final configurations.)

Pond Levels

Survey levels indicate that the normal pond elevation was 307.7 above mean sea level. This is the level of the remains of the old spillway crest, and is borne out by the old shore line, which is still distinguishable. This elevation is proposed for the new spillway crest.

Old property plans show the high water level as a drill hole in a rock above the dam, which we found at elevation 310.40. This is apparently the limiting elevation for flowage rights. We have assumed that for unusual floods it will be necessary to allow the pond level to exceed this elevation by 3 to 4 1/2 feet, which would reach above the floor levels of a few cottages and cause other temporary inconveniences. In fact, elevation 310.40 reaches near the sill of one cottage. Since this high level might occur only once or twice in a lifetime, we feel it would be tolerable.

Layout "A"

The first layout considered was the normal approach with the spillway in the north abutment of the dike, and a sluice pipe through the deep section of the dike. Since this requires a paved channel to the river, we used a 50-foot spillway crest and 7-foot pond rise. This is the maximum permissible rise without saddle dams.

This scheme is appended as Layout "A". This approach is least expensive to build, and with favorable bids for borrow could be

(Conant Brook at Monson Reservoir, 1955). Rare flood runoff was computed as 258 cubic feet per second per square mile, and the adjusted rare flood as 715 cfs per square mile. This was reduced by routing with an empirical hydrograph to a spillway capacity of 460 cfs per square mile, or a total spillway capacity of 3500 to 3600 cfs.

There are no gaging data available on West River. Mr. Childs, of the Corps of Engineers, informed us that in their studies for West Hill Dam they had located high water marks at Waukentuck Mills (drainage area 28 square miles) and had computed the following runoff peaks for recent storms.

<u>Year</u>	<u>Peak</u>	<u>Peak/square mile</u>
1936	1340 cfs	49 cfs
July 1938	1340 "	49 "
Sept. 1938	2380 "	85 "
Aug. 1955	6000 "	214 "

Since the Jourdan Pond watershed is roughly one fourth this area, considerably higher unit runoffs might be expected. It is of interest that the spillway design runoff being considered for West Hill at the time of our discussion was 26,000 cfs, or around 900 cfs per square mile for an area some four times that of Jourdan Pond. This is felt to be more conservative than could be justified for a pond the size of Jourdan Pond.

Runoff and routing computations are appended.

Hydrology

The West River watershed above the dam site is about five miles long, one to two miles wide, and contains 7.84 square miles. The average elevation is 150 feet above the pond, and the average run-off distance to Jourdan Pond is about two miles. The river runs the full length of the valley and with its tributary brooks drains sizable swamp areas, mostly on the valley floor.

Two ponds, Cider Mill Pond and Silver Lake, are located on the river above Jourdan Pond. Cider Mill Pond, the farthest upstream is largely silted up and may be disregarded. Silver Lake, while partly silted, still has a sizable pool (0.043 square miles) and would seriously affect the water level at Jourdan Pond should the Silver Lake Dam fail.

Silver Lake is contained by an old stone masonry and earth dam with an inadequate spillway, a sketch of which is appended. While this dam withstood overtopping in 1955 and presumably at other times in the past, it is not considered safe for current design floods, nor can Jourdan Pond be considered completely safe for design conditions in the event of a failure at Silver Lake near the flood peak.

Runoff was computed by the Kinnison-Colby method, and adjusted for the greatest measured runoff in a nearby area of similar size

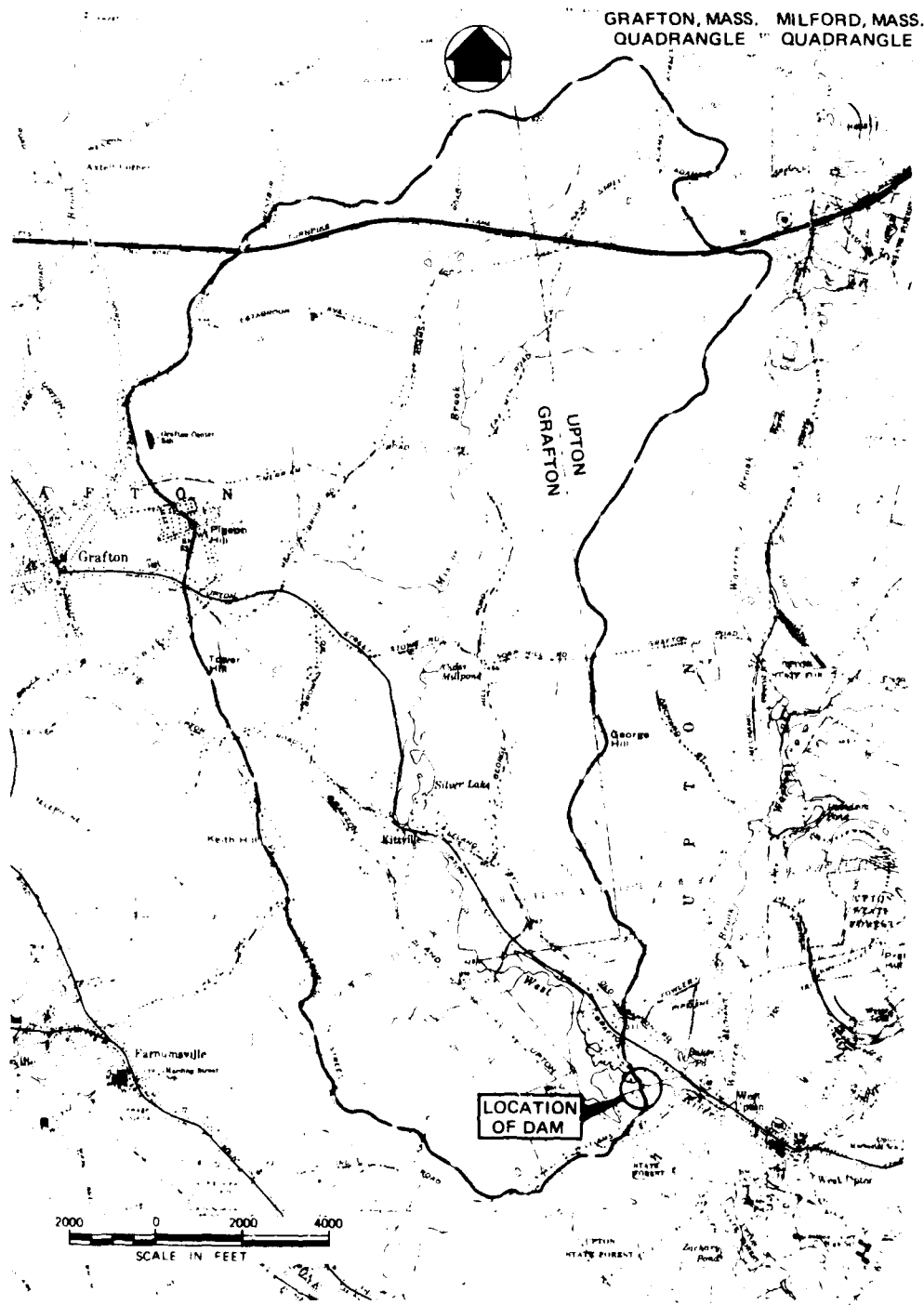

FIG. D-1 DRAINAGE AREA MAP - WILDWOOD LAKE

Project Nat. Review of Non Fed. Dams Acct No. 6191 Page 1 of 4
 Subject Worcester County, Mass. Comptd By LEB Date 1/2/79
 Detail WILDWOOD LAKE DAM Ckd By MBA Date 1/4/79

I Test Flood, Storage & Storage Functions

1- Total Drainage Area - 7.65 mi²

2- Pond(s) Area: .057 + .084 = 0.091 mi²
 Swamp(s) Area: .108 + .024 + .093 + .026 + .339 + .063 + .043 = 0.696
 Total Area Ponds & Swamps: 0.787

% Ponds & Swamps = $\frac{0.787}{7.65} \approx 10\%$

3- $\frac{640 - 307}{22300} = 1.49\%$ } Say Ave Slope = 1.5%

4- Using C. of E. Curves for Peak Flow Rates & above guide values the Peak Flow Rate was estimated to be somewhat above Flat & Coastal and taken at 1000 c.f.s./mi²
 Size Class: Small ; Hazard Pot.: Signif. ; Spill. Des. Flood: 100yr to 1/2 PMF
 Use: Test Flood = 1/2 PMF

5- Test Flood Inflow = 1/2(1000) 7.65 = 3800 c.f.s.

6- Pond Storage

The pond area is 0.057 sq. mi. at elev. 307.7
 Based on a const. area, storage increases at 36.3 ac. feet per foot of depth increase.
 At pond el. 316, 301 ac. ft. are stored above the spillway crest.

7- Spillway crest elev. is 307.7 (where D = 0)

8- Storage Functions are based on $Q_{out} = Q_{in} [1 - \frac{S_{out}}{R}]$

S_{out} = Storage Vol. in Reservoir related to final Q_{out} in terms of inches of rain over the drainage area.

S (in Inches) = $12 D (\frac{.057}{7.65}) = 0.089 D$; $R = 6$ hr rain of storm

D = Storage depth in feet above spillway crest in reservoir

9- Storage Functions: (Test Flood & 1/2 PMF - if needed)

$F_{TF} = 3800$	$- 403 S$	$= 3800 - 36 D$
$F_{1/2 PMF} = F_{TF}$	$-$	$S = - D$

METCALF & EDDY, ENGINEERS

Project Nat. Review of NonFed. Dams Acct No. 6191 Page 3 of 4
 Subject Worcester County, Mass. Comptd By LEB Date 1/2/79
 Detail WILDWOOD LAKE DAM Ckd By MBP Date 1/4/79

Lead 11/1/79

② Discharge Ratings

A. Spillway

Shape "ogee", length - 75', Crest El. 307.7

$$\text{Use } Q_s = CL(H_s)^{1.5} = 4.0(75)(H_s)^{1.5}$$

Pond El.	308	310	312	314	316	318
H_s	0.3	2.3	4.3	6.3	8.3	10.3
Q_s	50	1040	2680	4770	7180	9920

B. Low Level Outlet

Sluice gate on face of opening. Short length. Size 4' x 4' thru spillway. losses $\approx 0.5h_v + 1.0h_v + 0.3h_v = H_L$
(entr.) (cont.) (exit)

$$H_L = 307.7 - 297.8 = 1.8h_v = 1.8 \frac{V^2}{2g}$$

$$V = \left[\frac{2g(9.9)}{1.8} \right]^{1/2} = 18.8 \text{ fps}; Q_L = 300 \text{ cfs}$$

Pond could be lowered 1' in approx. $\frac{36.3(43500)}{300(3600)} = 1.5 \text{ hours}$

METCALF & EDDY, ENGINEERS

III Discharge, Storage & Storage Function vs Pond Eleu.

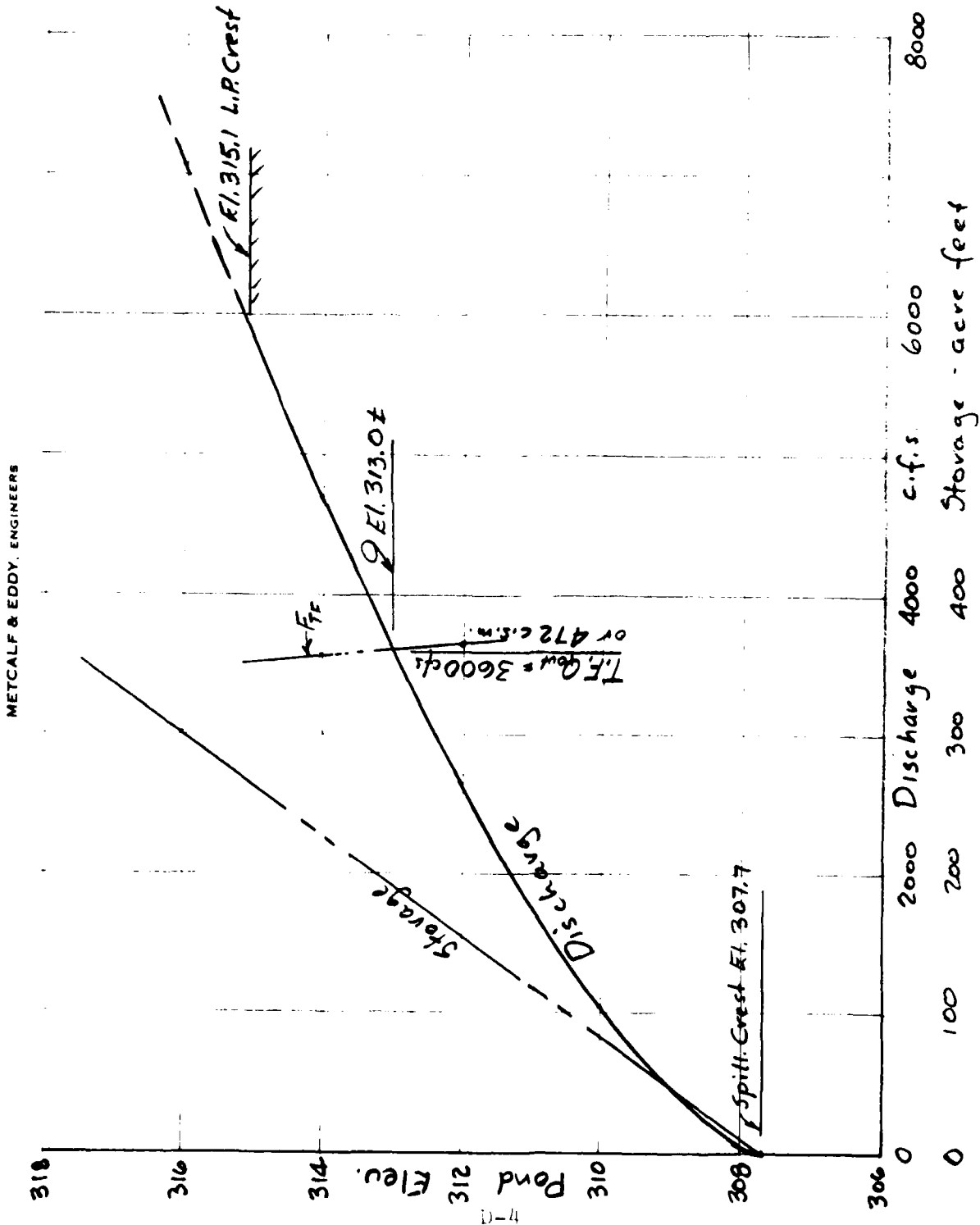

IV Failure of Dam

Peak Failure Flow:

Pond Elevation - 313 (approx. w.s. w/ T.F.)

Toe Elevation - 292 toe

$Y_0 = 21$

Dam Length Subject to Breaching = 150 (South embankt.)

$W_0 = 40\%(150) = 60 \text{ ft}$

$Q_{P1} = 1.68 W_0 (Y_0)^{1.5} = 1.68 (60) (21)^{1.5} = 9700 \text{ cfs}$

Total flow, incl. T.F., = 9700 + 3600 = 13,300 cfs

Storage Volume Released:

Storage Above Spillway $(313 - 307.7) 36.3 = 190 \text{ ac. ft.}$

Storage Below Spillway $\frac{1}{3}(21 - 5.3) 36.3 = 190 \text{ " "}$

$S = \text{Total Storage} = \frac{190}{380}$

Channel Hydraulics:

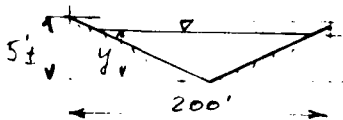

$S \approx \frac{2}{400} = .005, n = .08, V = 1.32 R^{4/3}$

$R \approx \frac{1}{2} y \therefore V = 0.83 y^{4/3}, A = 20 y^2$

y	A	V	Q
5	500	2.42	1200
10	2000	3.85	7700
7	980	3.04	3000
17	2880	4.35	12500
13	3380	4.59	15500

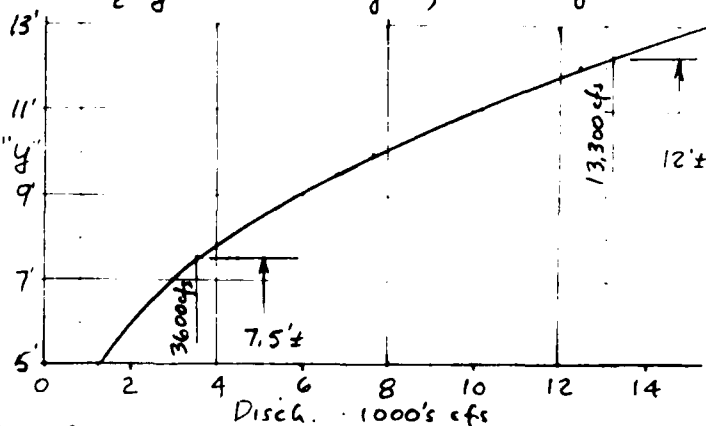

Channel is about 400 ft long before flow reaches small pond. Failure flows would spread in pond area, be restricted by Williams St. bridge.

Time to Drain:

$\frac{43560 (380)}{3600 (\frac{1}{2}) (9700)} = 0.95 \text{ Hours, or 57 Minutes}$

APPENDIX E
INFORMATION AS CONTAINED IN THE
NATIONAL INVENTORY OF DAMS

WILDWOOD LAKE

INVENTORY OF DAMS IN THE UNITED STATES

STATE	DIVISION	CONGR. DIST.	STATE	COUNTY	NAME	LONGITUDE (WEST)	REPORT DATE
MA	667	NED	MA	027	WILDWOOD LAKE DAM	713R.01	01 MAR 79

POPULAR NAME	NAME OF IMPONDMENT
JOURDAN POND	
REGION BASIN	NEAREST DOWNSTREAM CITY - TOWN - VILLAGE
01 06	WEST RIVER
	UPTON
	POPULATION
	3800

TYPE OF DAM	YEAR COMPLETED	PURPOSES	HYDRAULIC HEIGHT	IMPOUNDING CAPACITIES	DIST. OWN	FED	H	PHV	FED	S	C	S	A	VER/DATE
RECTPG	1963	CR	28	460	N									N N N 07MAR79

REMARKS

D/S HAS LENGTH	SPILLWAY TYPE	WIDTH	VOLUME OF DAM (CY)	MAXIMUM DISCHARGE (FT.)	YEAR COMPLETED	PURPOSES	HYDRAULIC HEIGHT	IMPOUNDING CAPACITIES	DIST. FROM DAM (MI.)	POPULATION
7	430	11	75	6000	1963	CR	28	460	0	3800

OWNER	ENGINEERING BY	CONSTRUCTION BY
TOWN OF UPTON	GREEN ENGINEERING AFF.	ABLONDI AND BOYNTON

DESIGN	CONSTRUCTION	OPERATION
	WORCESTER CITY ENGR	NONE

INSPECTION BY	INSPECTION DATE
METCALF AND EDDY INC.	27 NOV 78
	AUTHORITY FOR INSPECTION
	PUBLIC LAW 92-567

REMARKS

DATE
L MED
— 8