

AD-A155 766

2

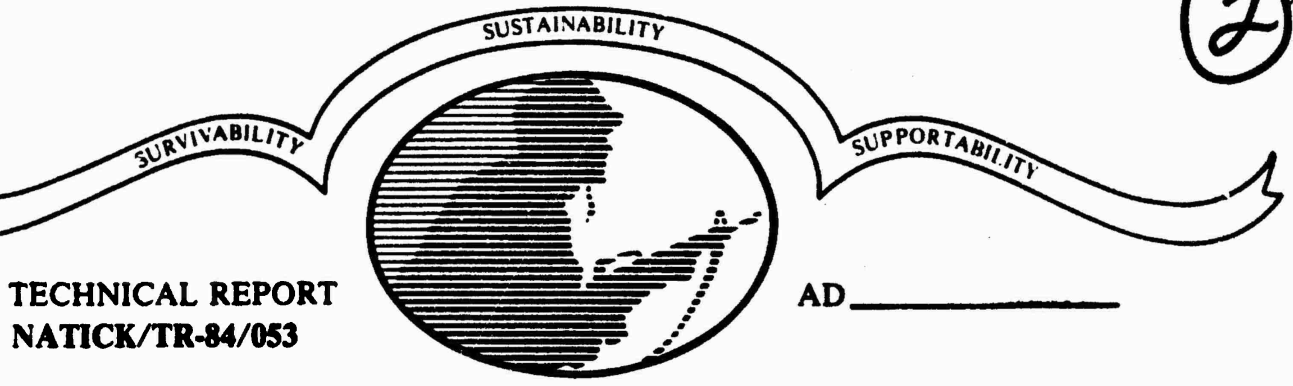

TECHNICAL REPORT  
NATICK/TR-84/053

AD \_\_\_\_\_

# SOFT AND SEMISOFT LANDING LIMITS OF M151 AND M35 MILITARY VEHICLES

BY  
WILLIAM NYKVIST  
JUNE 1984

DTIC  
ELECTE  
JUN 21 1985  
S B D

DTIC FILE COPY

APPROVED FOR PUBLIC RELEASE;  
DISTRIBUTION UNLIMITED

UNITED STATES ARMY NATICK  
RESEARCH AND DEVELOPMENT CENTER  
NATICK, MASSACHUSETTS 01760-5000  
AERO-MECHANICAL ENGINEERING LABORATORY

8 5 6 3 1 2 3

Disclaimers

The findings contained in this report are not to be construed as an official Department of the Army position unless so designated by other authorized documents.

Citation of trade names in this report does not constitute an official endorsement or approval of the use of such items.

DESTRUCTION NOTICE

For classified documents, follow the procedures in DoD 5200.1-R, Chapter IX or DoD 5220.22-M, "Industrial Security Manual," paragraph 19. For unclassified documents, destroy by any method which precludes reconstruction of the document.

REPORT DOCUMENTATION PAGE		READ INSTRUCTIONS BEFORE COMPLETING FORM
1. REPORT NUMBER NATICK/TR-84/053	2. GOVT ACCESSION NO.	3. RECIPIENT'S CATALOG NUMBER
4. TITLE (and Subtitle) SOFT AND SEMISOFT LANDING LIMITS OF M151 AND M35 MILITARY VEHICLES		5. TYPE OF REPORT & PERIOD COVERED 5/83 - 4/84
		6. PERFORMING ORG. REPORT NUMBER NATICK/TR-84/053
7. AUTHOR(s) WILLIAM NYKVIST		8. CONTRACT OR GRANT NUMBER(s) N/A
9. PERFORMING ORGANIZATION NAME AND ADDRESS US Army Natick Research and Development Center Aero-Mechanical Engineering Laboratory Natick, MA 01760-5017		10. PROGRAM ELEMENT, PROJECT, TASK AREA & WORK UNIT NUMBERS 6.2, 1L162210D283AH001
11. CONTROLLING OFFICE NAME AND ADDRESS		12. REPORT DATE June 1984
		13. NUMBER OF PAGES 31
14. MONITORING AGENCY NAME & ADDRESS (if different from Controlling Office) US Army Natick Research and Development Center Aero-Mechanical Engineering Laboratory Natick, MA 01760-5017		15. SECURITY CLASS. (of this report) UNCLASSIFIED
		15a. DECLASSIFICATION/DOWNGRADING SCHEDULE
16. DISTRIBUTION STATEMENT (of this Report) Approved for public release; distribution unlimited.		
17. DISTRIBUTION STATEMENT (of the abstract entered in Block 20, if different from Report)		
18. SUPPLEMENTARY NOTES		
19. KEY WORDS (Continue on reverse side if necessary and identify by block number) SOFT LANDING, AIRDROP OPERATIONS, IMPACT TESTING, AERIAL DELIVERY, MILITARY VEHICLES, LANDING IMPACT.		
20. ABSTRACT (Continue on reverse side if necessary and identify by block number) This study investigates soft and semisoft impact velocity limits of two frequently airdropped, uncushioned and semicushioned, military vehicles. A jeep and 2½-ton truck were tied down to an airdrop platform, raised to various heights, and released. Semisoft impacts were those in which some paper honeycomb stacks were slipped between the vehicle frame and platform. Time variation of vehicle acceleration, suspension travel, and bump stop contact were recorded; data for nineteen jeep drops and seven 2½-ton truck drops		

cont.

20. is presented here. The results of this study provide baseline data for design of a soft or semisoft-landing airdrop platform or airdrop system.

19

PREFACE

Past studies of impact cushioning for airdropped vehicles included comprehensive materials investigations and fragility tests. These studies, many sponsored by Natick Research and Development Center, were all concerned with materials and techniques for absorbing kinetic energy due to impact at the standard 28.5 ft/s (8.7 m/s) parachute descent velocity.

Determination of the maximum impact velocity and deceleration that typical uncushioned vehicles can withstand is the objective of this study. Data generated will be used to design a soft landing airdrop platform or an airdrop system for uncushioned military vehicles and equipment. This study goes one step further and also investigates the soft landing limits of a partially cushioned vehicle ("semi-soft" limits) where paper honeycomb is inserted beneath the frame at selected locations without the use of lifting or jacking equipment. This preserves the important drive-on/drive-off capability and increases the soft landing limits to more practical levels.

Appreciation is expressed to Nick Rosato, Engineering Technology Division, AMEL, for his expert help in setup and operation of transducers and data recording equipment, and to John Doucette and John Lupien of Experimental Analyses Branch, AMEL for obtaining the vehicles, skilled rigging assistance, and orchestrating the tests.

This work was funded under exploratory development Project 1L162210D283, Airdrop Technology, task AH, Soft Landing Concepts.

**DTIC**  
**ELECTE**  
**S** JUN 21 1985 **D**  
**B**

Accession For	
NTIS GRA&I	<input checked="" type="checkbox"/>
DTIC TAB	<input type="checkbox"/>
Unannounced	<input type="checkbox"/>
Justification	
By _____	
Distribution/ _____	
Availability Codes	
Dist	Avail and/or Special
A-1	



## TABLE OF CONTENTS

	Page
Preface	iii
List of Illustrations	iv
Introduction	1
Previous Studies	2
M151 1/4-Ton Truck	2
Description	2
Transducers	3
Data Recorders	4
Soft Landing Tests-M151	5
M35 2 1/2-Ton Truck	14
Description	14
Transducers and Data Recorders	15
Soft Landing Tests-M35	16
Discussion	26
Conclusions	28
Literature Cited	29
Appendix	30

## ILLUSTRATIVE DATA

### LIST OF FIGURES

Figure		Page
1	Overall view of jeep	2
2	Jeep rear view showing position of weight	2
3	Mounting of displacement transducers	3
4	Honeycomb stacks on drop 28: under vehicle and appearance after crush	7
5	Acceleration-time traces for selected drops, M151 jeep center of gravity	10
6	Displacement-time traces for selected drops, M151 jeep driver's side	11
7	Peak acceleration of M151 jeep vs. pitch angle for two impact velocities	12
8	Peak displacement and acceleration vs. impact velocity for M151 jeep	13
9	M35A2 truck	14
10	Accompanying load on truck bed	14
11	Displacement transducer mounts, M35 truck driver's side	15
12	Positioning of honeycomb under M35 truck	18
13	Honeycomb arrangement under center of M35 truck	19
14	Honeycomb appearance after impact, drop 15	20
15	Acceleration-time traces for M35 truck engine	22
16	Acceleration-time traces for M35 truck center of gravity	23
17	Displacement-time traces for M35 truck	24
18	Peak displacement and acceleration vs. impact velocity for M35 truck	25
A-1	Typical stress-strain curve for four 5 1/2 x 5 1/2 x 12-inch (14 x 14 x 30 cm) paper honeycomb stacks, impact velocity 23 ft/s (7 m/s)	30

LIST OF TABLES

Table		Page
1	Summary of M151 test data	6
2	Determination of honeycomb stack area	8
3	Summary of M35 test data	17



## SOFT AND SEMISOFT LANDING LIMITS OF M151 AND M35 MILITARY VEHICLES

### INTRODUCTION

This study investigates the dynamics and impact velocity limits of two uncushioned military vehicles to define airdrop soft landing limits. The results of this study will provide baseline data for design of a soft landing airdrop platform or airdrop system. The need for a soft landing system arises from a need for new airdrop capabilities as well as a desire to reduce undesirable aspects of the present airdrop system.

The present means of impact energy absorption for airdropped military vehicles features tall, glued, stacks of paper honeycomb carefully positioned on the platform beneath vehicle areas such as the frame, differential, and cross-members. Lifting the vehicle up onto these stacks during rigging requires a crane or heavy lifting device. The rigging procedure is labor-intensive and time consuming due to the cutting, gluing, and positioning of honeycomb and load spreaders as well as vehicle modifications, such as removing and stowing the muffler and spare tire. At impact, the honeycomb is crushed, effectively absorbing the impact energy, but it often gets crushed up under the vehicle making it difficult and time consuming to remove from, or drive off of, the platform.

The capability of airlanding an airdrop-rigged vehicle and getting it quickly deployed in a tactical situation cannot be achieved with the present system. There is no means to remove the loaded platform from the aircraft, and no means to remove the vehicle from the honeycomb stacks.

What is needed is a platform drive-on/drive-off capability where the vehicle is secured directly to the platform and impact energy absorption is built into the platform or into the airdrop system (for example retrorockets). Such a design would permit simplified rigging and much more rapid derigging, and an airland capability would be provided since the vehicles could be driven over the platforms and off the aircraft. No cranes would be needed to rig the vehicle, and preparation and conditioning of the vehicle for airdrop would be greatly reduced.

The vehicle itself has some energy absorbing qualities built into the suspension system, which could be taken advantage of in designing a new airdrop soft landing system. In this study, two frequently airdropped vehicles were tested; one lightweight vehicle, an M151 1/4-ton truck, and one heavy vehicle, an M35 2 1/2-ton truck. These uncushioned vehicles were secured to an airdrop platform, instrumented, and dropped from a series of heights. Vehicle suspension travel, accelerations, and bump stop contact were measured. At the drop height where damage was imminent, stacks of honeycomb were slid under frame members and additional, higher drops were carried out to determine how much soft landing limits could be raised with a "honeycomb assist". These drops were referred to as semi-soft landings.

## PREVIOUS STUDIES

Over the past 30 years, many studies in the area of airdrop impact shock absorption have been published. These studies were all concerned with cushioning methods for absorbing the impact shock from the standard 28.5 ft/s (8.7 m/s) descent velocity. A literature search was conducted for soft landing studies or fragility studies of uncushioned vehicles; none were found.

The studies carried out on cushioned vehicles were primarily done by the University of Texas Structural Mechanics Research Laboratory. A total of 100 reports were published, of which 56 were sponsored by the Natick Research and Development Center. Investigations included evaluation of energy absorbing materials and devices such as styrofoam, vermiculite concrete, felt pads, wood, fluid-filled metal cylinders, foamed plastics, airbags, aluminum honeycomb, foamed sulphur, popcorn, frangible tubing, and paper honeycomb. Several analytic studies were carried out to determine the dynamic response of vehicle models to sudden impacts inherent in airdrops, and many studies were devoted to determination of vehicle fragility using paper honeycomb as the energy dissipator. In the fragility studies, various honeycomb arrangements were experimented with to determine the optimum for specific vehicles. These studies demonstrated that properly conditioned and cushioned vehicles can withstand a deceleration of approximately 20 G (that is a decelerating force 20 times the rigged weight). Accordingly, Military Standard 669<sup>1</sup> specifies a deceleration force ratio, neglecting gravity, of  $18.5 \pm 10\%$  times the airdrop weight, achievable by using 3.1 ft<sup>2</sup> (0.3 m<sup>2</sup>) of paper honeycomb for each 1000 lbm of item airdrop mass (454 kg), with a total stack height of 12 in. (30 cm).

### M151 1/4-TON TRUCK (JEEP)

#### Description

A salvage M151 vehicle was obtained for this test program. The vehicle, hereafter called the jeep, was an M151A1C model with the following components missing: carburetor, spare tire, batteries, drive shaft, steering box, and steering wheel. For the tests, the seats, fuel tank, and windshield were removed. To compensate for the mass of the items removed or missing, a 400-lbm steel weight (182-kg) was attached to the bed. Fig. 1 and 2 show the jeep and the attached weight.

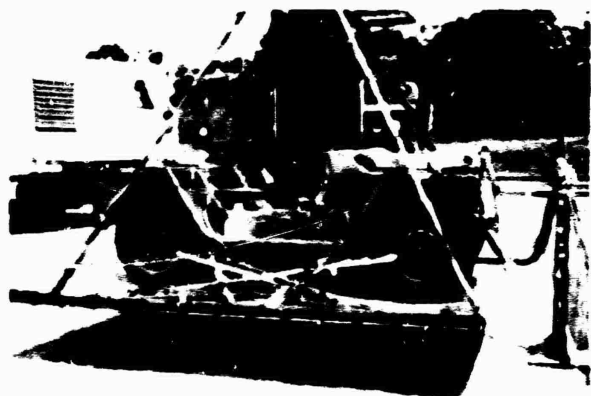

Figure 1. Overall view of jeep

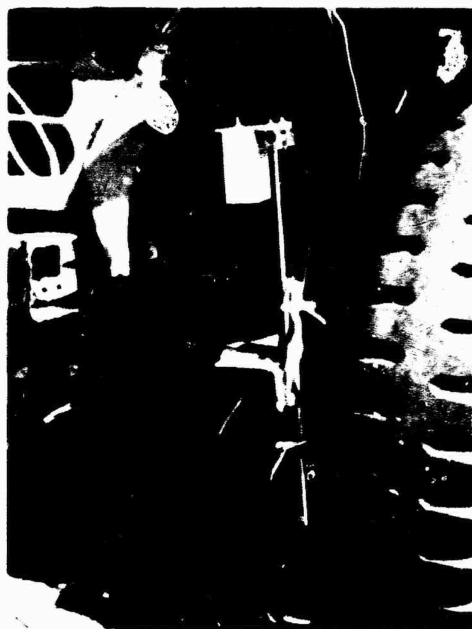

Figure 2. Jeep rear view showing position of weight.

The mass of the jeep, including the added weight, was 2390 lbm (1086 kg); the total mass with platform and tie-downs was 3067 lbm (1394 kg).

### Transducers

Trans-Tek model 246-000 displacement transducers were used at each of four suspension points. These are the DC to DC LVDT (linear variable differential transformer) type with a 8-inch (20-cm) stroke, a linearity of + 0.5 percent full scale, and a break frequency (3 dB down) of 75 Hz. Beyond 75 Hz, the LVDT behaves like a low pass filter due to the modulation/demodulation rolling off at 20 dB/decade. Steel plates were welded to the suspension and body to provide mounting points. Since the LVDT only measures straight-line displacement, and the suspension geometry is such that the wheels travel through an arc, mounting these transducers required the use of hinges. The core element of the LVDT is easily bent, so a double brass tube slider was clamped to the LVDT body to provide strain relief. Mounting hardware was nonmagnetic as required. Fig. 3 shows the LVDT mount on the left front and rear suspensions, respectively.



Front

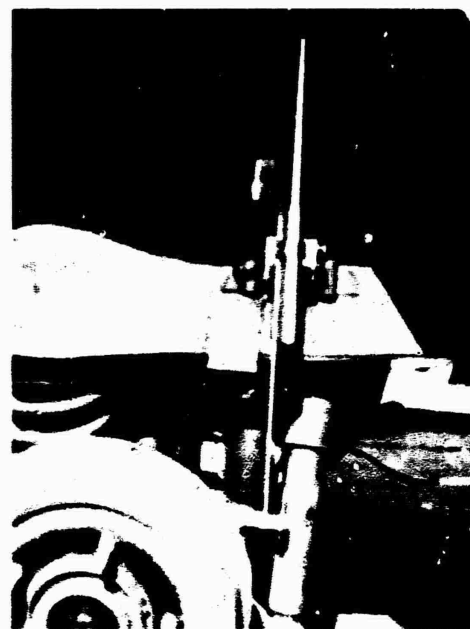

Rear

Figure 3. Mounting of displacement transducers.

Contact switches, Microswitch model BZ-2RW-A2, were installed at both rear rubber suspension bottoming protection devices, hereafter called bump stops. The front suspension does not have bump stops. For each rear bump stop, one switch closed when the bump stop contacted the frame, and a second switch closed when there was a 1/2-inch (1.3 cm) crush of the bump stop. Contact switches were also located at each corner of the airdrop platform; switch closure indicated contact with the ground.

Accelerometers were located on the engine (vertical), center of gravity (CG) (3-axis), and rear (vertical). The engine accelerometer was mounted on top of the intake manifold; the CG 3-axis accelerometer block was mounted on a frame member on the passenger side of the transmission housing adjacent to the passenger foot rest area; and the rear accelerometer was mounted on the bed at the rear, centered side-to-side. All accelerometers were a DC-excited strain gage type, Bell and Howell model 4-202-0001, range  $\pm 50$  g, damped to 0.6 to 0.8 critical at 77°F (25°C), natural frequency 880 Hz, with linearity and hysteresis less than 0.75 percent of full range output.

#### Data Recorders

Two eight-channel heated stylus analog data recorders were used to record the 17 data outputs. To accomplish this, the eight switch closure outputs were squeezed onto four data channels by using an R2R ladder network circuit. The two front platform contact switch outputs were wired through this resistive network such that three levels of output were created: one voltage indicated a front drivers side switch closure, a higher voltage indicated a front passenger side switch closure, and an even higher voltage indicated both switches were closed. This same network was used for the two rear platform contact switches, the two drivers side bump stop switches, and the two passenger side bump stop switches.

The four switch closure data channels and the three 3-axis accelerations were recorded on the Hewlett Packard model 7418A eight-channel thermal tip recorder. Each channel is 1.6 inches (40 mm) wide with 50 divisions, and the chart paper speed used was 4 in./s (100 mm/s). Model 8803A low level preamplifiers were used. Specified frequency response of the system (preamplifiers plus recorder power amplifiers) is  $\pm 1$  percent for DC to 20 Hz and DC to 3 dB down at 100 Hz. System linearity and hysteresis is better than 0.25 divisions over 50 divisions, and system step response is a 7-ms rise time from 10 percent to 90 percent of final value.

The four suspension displacements, the rear vertical acceleration, and the engine vertical acceleration were recorded on the Gulon TR-8000 eight channel recorder. Channels are 40 mm wide with 50 divisions and a paper speed of 100 mm/s was used, same as the HP 7418A recorder. Model TSC-820 signal conditioners were used; specified frequency response for 50 divisions peak-to-peak was 1 dB over DC to 35 Hz.

The event marker on the HP recorder was connected in parallel with a spare channel on the Gulston to provide a time reference for comparison of data on the two recorders. During a drop, the event marker button on the HP recorder was pressed several times, recording a pulse simultaneously on each recorder. This permitted time synchronization between the two recorders.

#### Soft Landing Tests - M151

A total of 34 drops of the jeep were carried out over the period 5/31/83 to 8/19/83; 19 of these drops are reported here. The other 15 were either preliminary, duplicates, or those with transducer or data recording problems. Original data is located in Laboratory Notebook 7478 pages 65 - 78.<sup>2</sup>

The drop tests were performed at Natick Research and Development Center on the reinforced concrete drop pad. This extremely rigid surface presents the worst case condition with regard to impact shock. Suspension slings were attached to the 12-ft (3.7-m) type II airdrop platform to which the jeep was tied down, and brought to a confluence point by means of a large clevis. A release mechanism was used to connect the clevis to the hook of the crane. A snag line was tied between the clevis and crane hook so the clevis and slings, when released, did not "slingshot" down onto the jeep.

Both the uncushioned drops and the paper honeycomb cushioned drops were conducted with level attitude and 8 degrees pitch. In addition, two uncushioned drops were performed with 8 degrees roll attitude. Table 1 summarizes data for the drop tests.

Drops 7 through 12 were conducted with a level platform attitude, starting with a 6-in. (15-cm) drop height, and incrementing by 6 in. (15 cm) up to a drop height of 30 in. (76 cm). Bump stop contact was first made on the 18 in. (46 cm) drop, and the 24 and 30 in. (61 and 76 cm) drops recorded more than 1/2 in. (1.3 cm) bump stop crush. For the 30 in. (76 cm) drop, the rebound energy of the jeep caused the jeep and platform to bounce approximately 3 inches. Additional uncushioned drops above this height were not conducted since suspension forces would increase substantially with little increase in stroke, and serious damage very likely would have resulted.

Drops 13 to 18 were conducted to determine vehicle response to oblique impacts. Typically, airdropped cargo can have a system angle with respect to vertical as much as 30° due to oscillations for single parachutes, but usually 10° or less in clusters. These tests investigated typical clustered parachute oscillation angles of  $\pm 8^\circ$  pitch and roll at three different average (center of jeep) drop heights.

In drops 21 to 32, paper honeycomb was used to increase the soft landing impact velocity. The paper honeycomb was cut into appropriate size squares, glued to create stacks 12 inches (30 cm) high, and inserted between the jeep frame and platform. In this soft landing work, it was intended that any paper

TABLE 1.  
Summary of M151 Test Data

Drop No.	Date	Drop Height (In)	Platform Attitude (Deg)	Impact Velocity (FPS)	Peak Vertical Accelerations (G)	Rear		Peak Suspension Displacements (In)			Paper Honeycomb (In. x In.)	Honeycomb Avg Crush (In)
						Engine	CC	FD	FP	RD		
7	7/14/83	6	0	5.7	1.8	2.0	2.2	1.5	2.0	1.6	1.2	-
8	7/14/83	12	0	8.0	-	-	2.7	2.5	2.8	3.0	2.5	-
10	7/20/83	18	0	9.8	5.6	6.3	4.0	3.2	2.9	3.5	3.4	-
11	7/21/83	24	0	11.3	5.6	8.0	4.8	3.4	2.9	4.2	4.0	-
12	7/21/83	30	0	12.7	8.0	9.6	6.5	3.4	3.1	4.5	4.4	-
13	7/21/83	12	-8 Pitch	8.0	1.2	0.8	4.4	1.0	0.4	4.1	4.0	-
14	7/21/83	24	-8 Pitch	11.3	3.2	4.5	8.8	3.0	2.4	4.6	4.5	-
15	7/27/83	12	+8 Pitch	8.0	4.0	4.6	0.8	3.2	3.0	0.8	0.8	-
16	7/27/83	20	+8 Pitch	10.4	6.2	9.2	3.6	3.2	3.2	2.9	3.0	-
17	7/27/83	12	-8 Roll	8.0	3.2	2.2	2.5	1.8	3.0	1.8	3.7	-
18	7/29/83	24	+8 Roll	11.3	11.2	7.2	4.3	3.0	3.0	3.3	4.3	-
21	8/3/83	36	0	13.9	11.1	10.2	9.0	3.0	3.4	4.1	4.2	5 1/2 x 5 1/2
22	8/4/83	42	0	15.0	12.0	10.4	8.4	3.1	3.2	4.0	4.2	8 x 8
23	8/4/83	48	0	16.0	14.4	13.6	10.4	3.0	3.2	4.0	4.0	9 x 9
27	8/16/83	42	0	15.0	9.6	9.0	6.8	3.0	3.0	4.2	4.4	5 1/2 x 5 1/2
28	8/16/83	48	0	16.0	12.0	10.0	8.4	3.3	3.0	4.4	4.6	7 x 7
29	8/16/83	60	0	17.9	15.0	12.4	10.0	3.2	3.1	4.6	4.6	6 1/2 x 6 1/2
31	8/17/83	36	+8 Pitch	13.9	6.0	5.9	8.2	3.2	3.0	4.5	4.6	5 1/2 x 5 1/2
32	8/17/83	36	-8 Pitch	13.9	9.8	11.2	6.4	3.4	3.2	4.1	4.3	5 1/4 x 5 1/4

honeycomb installed beneath the vehicle should be done without the need for any lifting device. This would keep rigging the vehicle simple and quick compared to the present system. There is a problem when the vehicle is rigged this way, however. When the jeep is released and is free-falling to the ground, the suspension system is unloaded, and the suspension and frame move apart. The honeycomb then is free to move around prior to impact, and did so in some preliminary drops. In actual airdrops, the strong, turbulent air velocity during deployment would quickly blow away any honeycomb not securely installed. Tightening the tie-down straps helped somewhat, but did not solve the problem.

In some of the early drops with paper honeycomb, drops 21 to 23, the jeep was jacked up slightly to install the honeycomb (contrary to the philosophy just mentioned) and no load spreaders were used where the honeycomb contacted the 3 - inch (7.6-cm) wide frame members. In drops 25 thru 32, upper load spreaders were used made of plywood and pieces of 2 x 4 pine. Also, a layer of 2-inch (5-cm) thick polyurethane foam, squeezed to 1 inch (2.5 cm) or less, was added under the stack to maintain compression when the suspension released during free-fall. Fig. 4 shows the honeycomb stacks in place for drop 28, and the appearance of the crushed stacks after the drop. An uncrushed stack was included for comparison.



Under vehicle.



After crush.

Figure 4. Honeycomb stacks on drop 28- position under vehicle and appearance after crush.

As a starting point for sizing the honeycomb needed for drops greater than 30 inches (76 cm), it was noted that in drop 12 the impact kinetic energy of 6011 ft-lb (8150 J) was dissipated without damage occurring. In this drop, analysis of the high-speed motion picture film showed that jeep frame travel relative to the platform, or stroke, was 9 inches (23 cm). Adding honeycomb between the vehicle frame and platform will reduce the stroke somewhat, so it was assumed the vehicle alone could dissipate 5000 ft-lb (6780 J) of kinetic energy. Assuming a stroke of 8 inches (20 cm) and using the degraded value of crushing stress of 3600 lb/ft<sup>2</sup> (172 kPa) (see Appendix for determination of this value), the area of honeycomb needed to absorb the kinetic energy in excess of 5000 ft-lb (6780 J) was calculated, and is shown in Table 2. The nominal crushing stress of paper honeycomb is 6300 lb/ft<sup>2</sup> as specified by MIL-H-9884D.<sup>3</sup>

TABLE 2. Determination of Honeycomb Stack Area

Drop Height (in.)(cm)		Excess Kinetic Energy (ft-lb) (J)		Total Honeycomb Area Needed (in. <sup>2</sup> ) (cm <sup>2</sup> )		Individual Stack Size (in./side)(cm /side)	
36	91	2200	2983	132	852	5.7	15
42	107	3385	4590	203	1310	7.1	18
48	122	4660	6319	280	1804	8.4	21
60	152	6940	9410	416	2686	10.2	26

In drops 21 to 23 the honeycomb area determined by this method reduced the stroke at impact excessively; strokes ranged from 3.7 to 5.2 inches (9 to 13 cm). Peak accelerations were substantially higher due to the reduced stroke. For the remaining drops, the stack size was reduced to provide for more stroke and less acceleration. Accordingly, peak accelerations decreased and strokes increased.

Acceleration-time traces for five representative drops are shown in Fig. 5. Time zero was arbitrarily chosen where the acceleration crossed the 1-G line. Peak accelerations listed have the 1 G due to gravity subtracted out and therefore only represent acceleration exerted on the jeep to arrest its vertical velocity. Displacement-time traces for the front and rear driver's side for the same five drops are shown in Fig. 6.

An analysis of the pitched impacts, drops 13 to 16, is shown in Fig. 7 where peak acceleration is plotted against pitch angle. Zero degree pitch drops 8 and 11 are also included. The impacts with the front end raised were more severe than equivalent flat impacts due to the 55/45 front-to-rear weight distribution and the stiffer front suspension.



As a final comparison of jeep impact data, peak suspension displacement and acceleration is plotted against impact velocity in Fig. 8. Addition of paper honeycomb either reduced peak displacement (front) or kept it from increasing (rear). Beyond approximately 13 ft/sec (4 m/s), peak accelerations would increase dramatically without the addition of honeycomb; rear bump stop compression would be substantial, and suspension forces would increase with only tiny increases in stroke. The honeycomb dissipated kinetic energy during the stroke, effectively increasing the impact velocity at which suspension forces become dangerously high.

The vehicle was inspected after each drop for damage, especially the engine mounts. After drop 29 an existing crack on the driver's side engine mount enlarged. This crack was adjacent to the machine screw and washer holding the mount to the jeep frame. It appeared the washer was too small, not spreading the machine screw bearing area adequately. An additional larger washer was added below the first, and no further crack growth appeared in subsequent drops.

In two additional drops not included in Table 1, from 42 and 48 inches (107 and 122 cm) height, honeycomb stack heights of 9 inches (23 cm) instead of 12 inches (30 cm) were used to see if more even crush could be obtained. The idea was that the shorter stack would be more stable and there would be less tendency for buckling. The stacks did in fact crush more vertically and evenly, but accelerations were higher. The crush stroke was 7 inches (20 cm), which is 86% strain; beyond 70% strain, the crushing stress of paper honeycomb increases greatly.

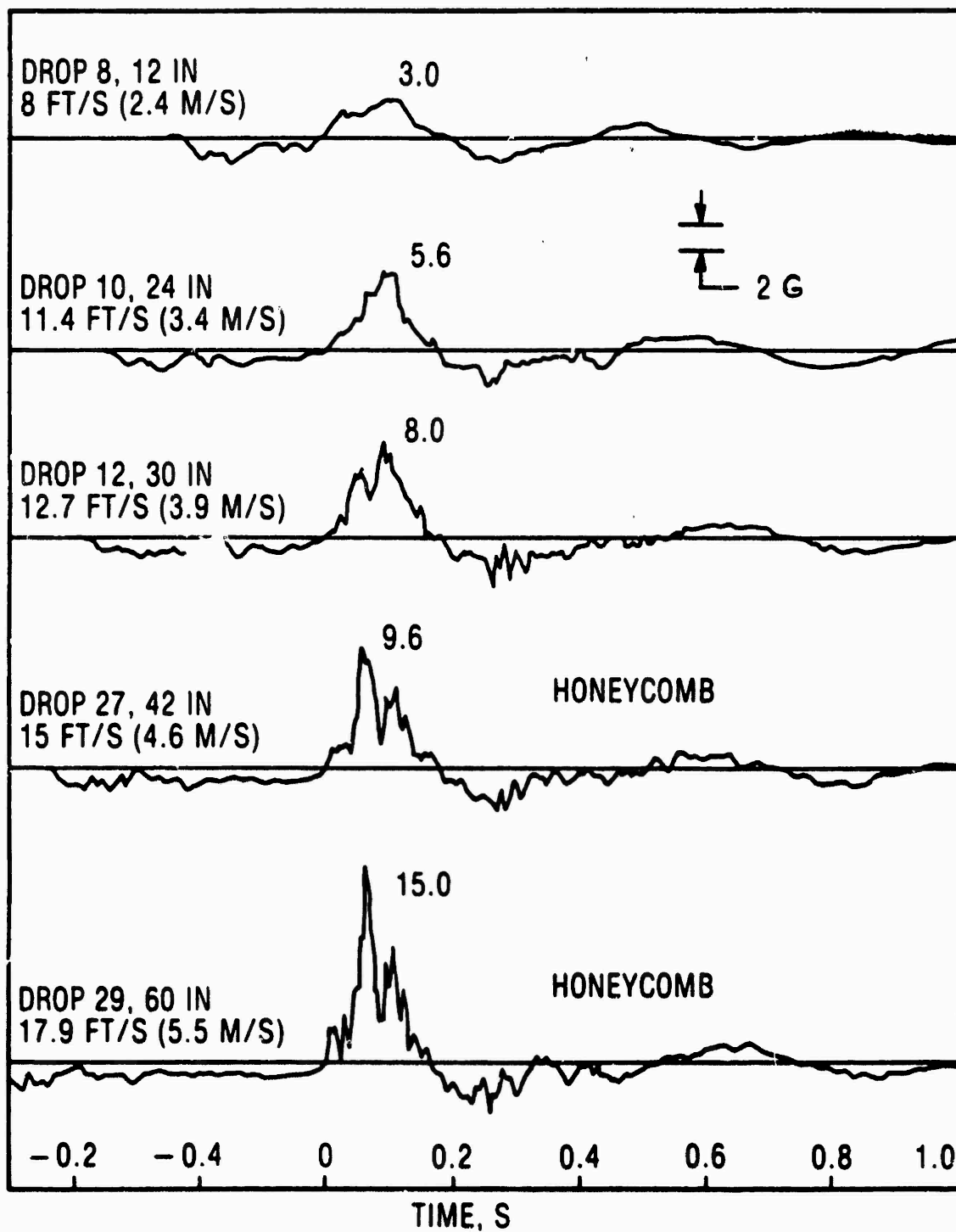

Figure 5. Acceleration-time traces for selected drops, M151 jeep center of gravity.

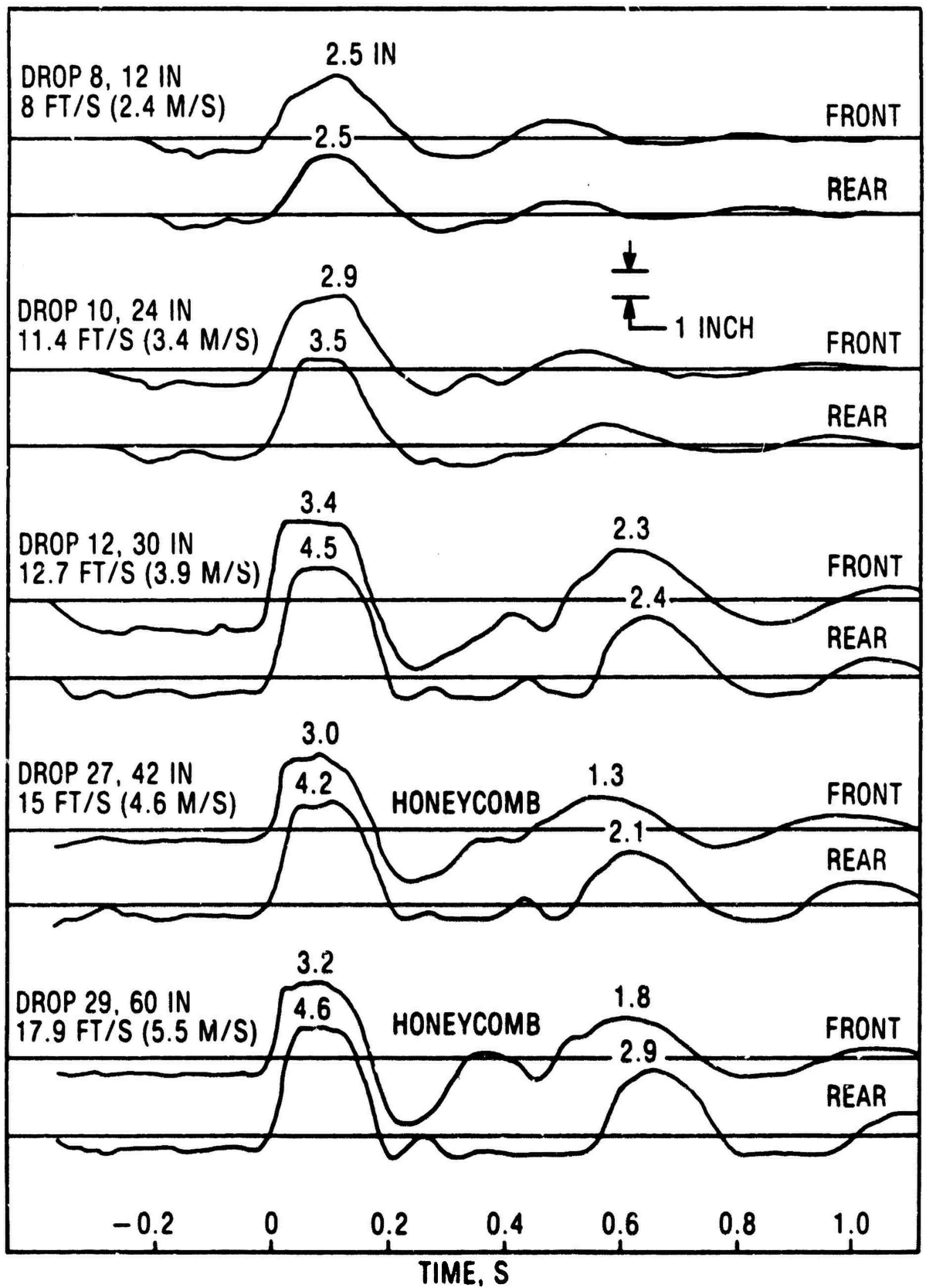

Figure 6. Displacement-traces for selected drops, M151 jeep driver's side.

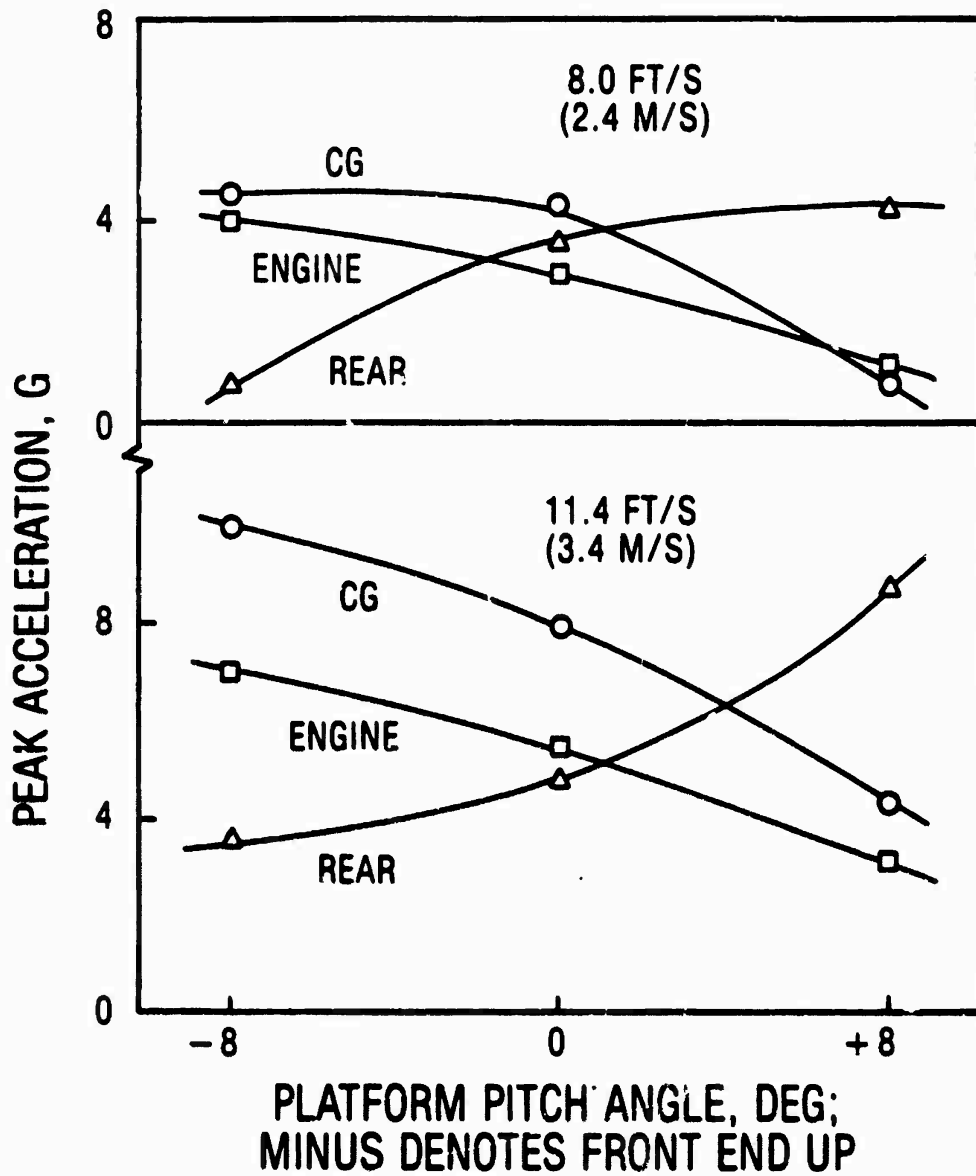

Figure 7. Peak acceleration of M151 jeep vs. pitch angle for two impact velocities.

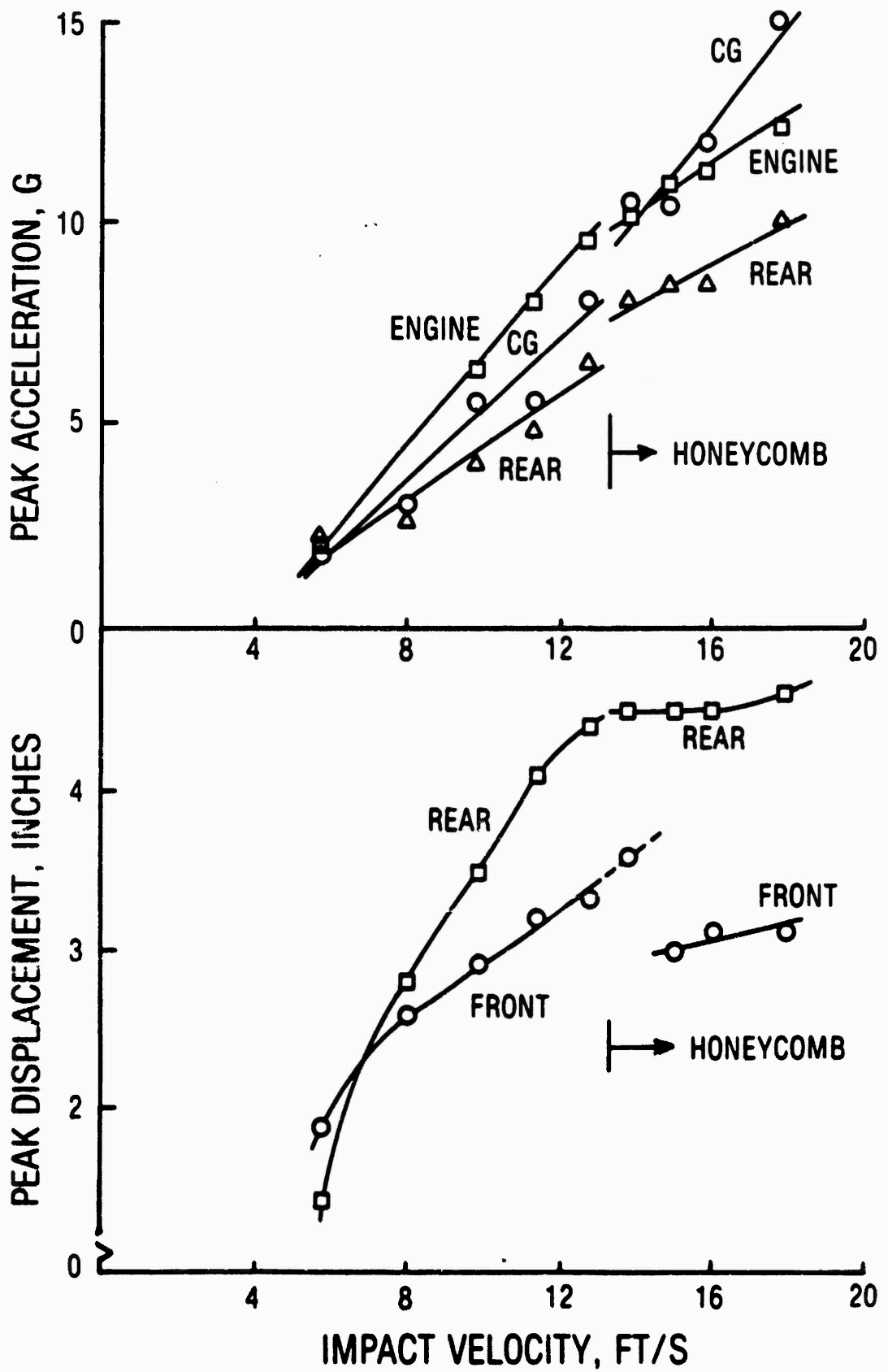

Figure 8. Peak displacement and acceleration vs. impact velocity for M151 jeep.

## M35 2 ½-Ton TRUCK

### Description

An M35A2 Truck, model year 1966, was obtained on loan from the Natick Research and Development Center motor pool. This truck was routinely used around the Center and was in good condition. For the test series, the fuel tank was drained so that only about one inch of fuel remained, for safety. Also removed was: spare tire, cab frame, front and side racks, bows and canvas cover, and side view mirrors. The windshield was padded, rotated forward onto the hood, and tied down. The truck was equipped with a winch on the front end, and its unrigged mass was listed as 13,530 lbm (6150 kg.). After one test drop to check the instrumentation, an accompanying load of 2400 lbm (1090 kg) was added to the bed centered over the rear wheels. This load consisted of six 400-lbm (180 kg) steel weights. Figure 9 shows the truck prior to the test program, and Figure 10 shows the accompanying load raised up on pallets and honeycomb and tied down to the bed.



Figure 9. M35A2 Truck

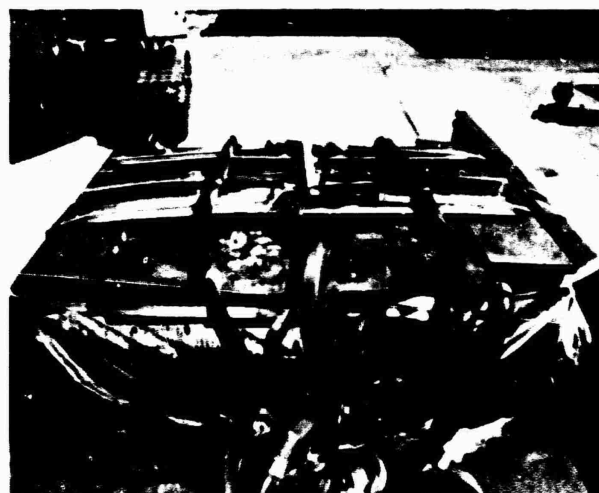

Figure 10. Accompanying load on truck bed.

The truck was tied-down to a 24-ft (7.3-m) Type II airdrop platform with mass approximately 1200 lbm (545 kg) so the mass of the truck, accompanying load, and platform was 17,130 lbm (7786 kg). The suspension slings were attached directly to the truck at the front and rear; attachment points can be seen in photographs appearing later in the report.

## Transducers and Data Recorders

The same Trans-Tek displacement transducers used on the jeep were used here. Only two were installed, front and rear on the driver's side. Fig. 11 shows the installed transducers. The rear transducer was mounted adjacent to the rearmost bump stop of the tandem wheel; as only level drops were conducted, only one rear displacement transducer was deemed necessary.



Figure 11. Displacement transducer mounts, M35 truck drivers side.

Bump stop contact switches were installed at front and rear drivers side bump stops, and can also be seen in Fig. 11.

Accelerometers were located on the engine, on the frame near the CG, and on the frame at the rear. Accelerometers were Entran EGA-125F-25D, range  $\pm 25$  G, damped 0.7 critical, with natural frequency 1000 Hz and nonlinearity  $\pm 1\%$ ; all were mounted to sense vertical accelerations. A ground contact switch was located on the front of the airdrop platform.

Data recorders used were the same used with the jeep drops, HP 7418A and Gulton TR-8000. The two suspension displacements and three accelerations were recorded on the HP 7418A, and the ground contact and bump stop switch outputs were recorded on the Gulton TR-8000. As before, a pulse was recorded simultaneously several times during the drop on both recorders, permitting a time synchronization between recorders.

## Soft Landing Tests - M35

A total of 15 drops of the 2 1/2-ton truck were carried out over the period 11/15/83 to 4/10/84; seven of these drops are reported here. Other drops were either preliminary, duplicates, or had data recording problems. Paper jams in the recorder especially plagued this series of drops. Original data is located in Laboratory Notebook 7478, pages 81-942.<sup>2</sup>

A decision was made to drop this vehicle only in a level attitude since it was an inventoried truck on loan and was needed, preferably undamaged, as soon as we finished testing it. Also, the jeep drops had already given us an idea of what to expect with oblique impacts. Only the driver's side was instrumented with displacement transducers and bump stop switches, since in level jeep drops, very little difference was observed between driver and passenger side data.

Table 3 summarizes data for the drop tests. As with the jeep, we started from a drop height of 6 inches (15 cm) and incremented by 15 cm on each successive drop. Front bump stop contact was made on the lowest drop height and on all subsequent drops. The clearance between the frame and the front bump stop is only 2.2 inches (5.6 cm). Rear bump stops never touched the frame in any of the drops; maximum recorded suspension travel was about 3 1/2 inches (9 cm) and the rear frame bump stop clearance was measured to be 4 inches (10 cm) with the accompanying load in place. At a 24-inch (61-cm) drop height, review of the high speed motion picture film showed a bounce of the truck and platform of about 3 inches (7.6 cm). Peak accelerations were at 15 G, so the decision was made to go to honeycomb drops rather than risk damage to the truck at an uncushioned 30-inch (76-cm) drop.

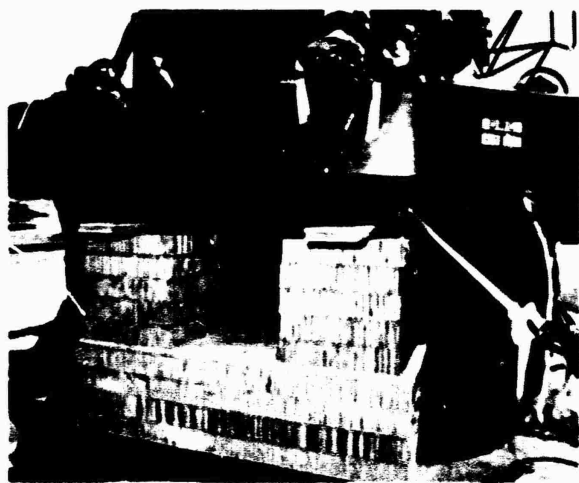

TABLE 3. SUMMARY OF M35 TEST DATA

DROP NO	DATE	DROP HEIGHT (IN)	IMPACT VELOCITY (FPS)	PEAK CC (G)	ACCELERATIONS		PEAK SUSPENSION DISPLACEMENTS (IN)		PAPER HONEYCOMB SIZE (INxIN)	
					ENGINE (G)	REAR (G)	FRONT	REAR	SIZE (INxIN)	AV CRUSH (IN)
6	11/22/83	6	5.7	5.6	3.2	16	2.8	1.6		
7	11/23/83	12	8.0	9.6	8	21	3.2	3.2		
8	11/23/83	18	9.8	13.6	12	25	3.5	3.4		
10	11/23/83	24	11.4	15	15	40	3.6	-		
11	12/16/83	36	13.8	14	18	35	3.4		FOUR 15x15	3.4
12	1/5/84	36	10.8	-	11	17	3.2	3.1	SIX 15x15	3.5
15	4/10/84	42	15.0	18	13.5	15	3.5	-	SIX 15x15	3.6

In determining the area of paper honey comb needed, a honeycomb crush force with magnitude equivalent to a 3-G truck deceleration was arbitrarily chosen. Using a crushing stress of paper honey comb of 6300 lb/ft<sup>2</sup> (301 kPa) and a vehicle mass of 15,500 lbm (7045 kg) the honeycomb area required was 7.4 ft.<sup>2</sup> (0.7m<sup>2</sup>). Divided into four equal stacks, the size would be 16 inches (41 cm) square. For drop 11, four stacks of honeycomb were used, each measuring 15 inches (38 cm) square. A stack size of 15 inch (38 cm) square was chosen over the 16 inch (41-cm) size because it would provide more stroke. Fig. 12 shows the positioning of the honeycomb. For this drop, the front end upper load spreader was inadvertently left out. The lower four layers of honeycomb are just used as dunnage, and did not crush due to the presence of the intermediate plywood load spreader.

Inspection of the truck after drop 11, the first honeycomb drop, revealed that the two main frame members were bent downward about 1 inch (2.5 cm) with the deepest part of the bend just below the point where the cab and truck bed meet. A gap of ¼ in. (1.3 cm) was visible between the truck bed frame and the main frame. Also the battery box cover incurred a slight buckle.



Front

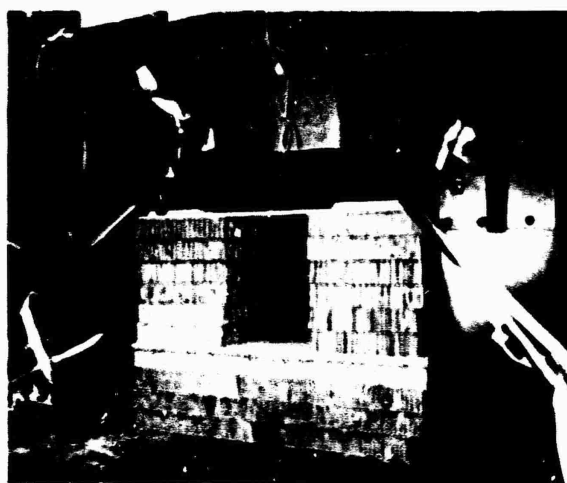

Rear

Figure 12. Positioning of honeycomb under M35 truck.

For the next drop, an arrangement of honeycomb was designed for installation below this bent area of the frame. The presence of the fuel tank and spare tire bracket, and proximity of the muffler and drive shaft made installation quite difficult. Fig. 13 shows the arrangement used. Thus for drop 12 there were six 15 inch (38-cm) square stacks compared to four in the previous drop.

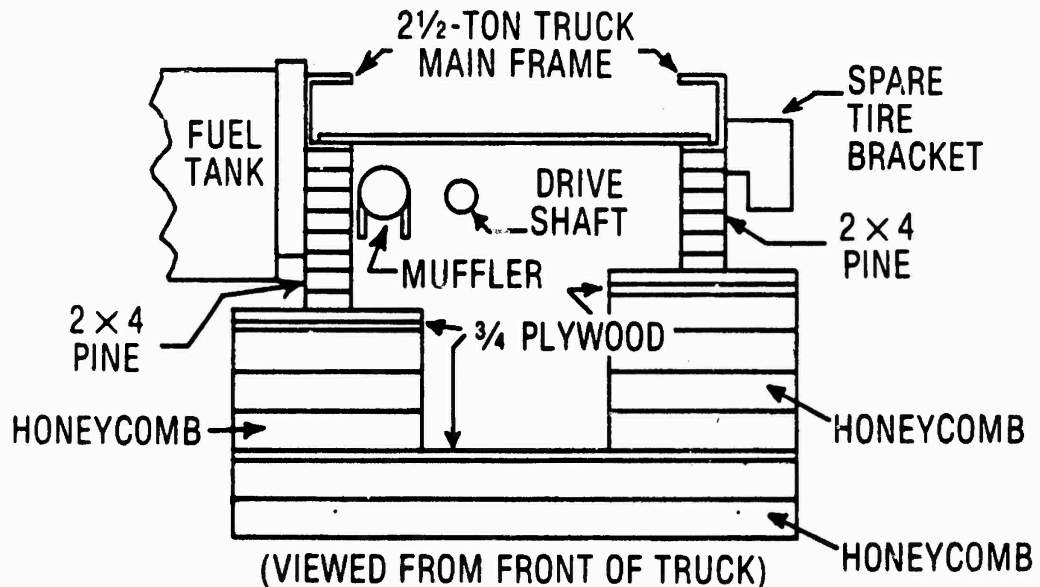

Figure 13. Honeycomb arrangement under center of M35 truck.

Results of drop 12 were much better, with no additional frame bending taking place. When the vehicle was lifted prior to the drop, gaps of  $1\frac{1}{2}$  to 2 inches appeared between the honeycomb and frame; this occurred because the truck, not the platform, was being lifted. Additional plywood shims were added prior to the drop, assuring more honeycomb crush.

The appearance of honeycomb after crush is shown for drop 15 in Fig. 14.



Front

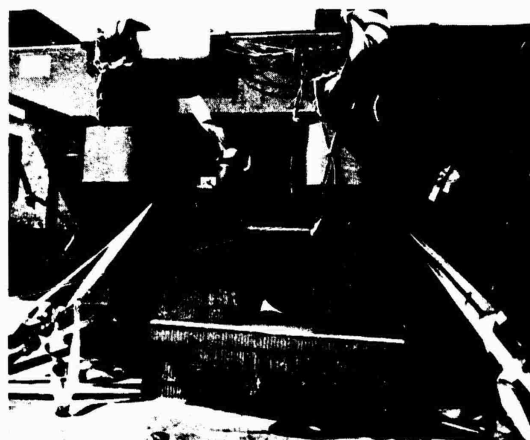

Rear



Center

Figure 14. Honeycomb appearance after impact, drop 15.

The front honeycomb popped out as shown after the major crush stroke; this is the only drop where the pop out occurred and it can be attributed to inadvertently leaving out the top 15-by 45-inch (38-by 114-cm) plywood load spreader. Also, for all drops the honeycomb was not glued so that uncrushed layers could be reused. For an airdrop, stacks would be glued. Center honeycomb stacks crushed much more evenly in previous drops than in drop 15.

Acceleration-time traces for four representative drops for the engine and center of gravity are shown in Fig. 15 and 16. The large mass of the engine was relatively vibration-free compared to the frame where the CG accelerometer was mounted. Displacement-time traces for the four drops are shown in Fig. 17. For drop 7 it is evident the rear suspension has a higher natural frequency than the front. The truck was designed to carry a 5000-lbm (2270-kg) load, and the accompanying load was only 2400 lbm (1090 kg), so when the front suspension system is on the rubber bump stop, the rear suspension still has approximately 1 inch (2.5 cm) of travel before bump stop contact. Also, the eight wheels in the rear compared to the two wheels in the front contribute to a higher spring constant for the rear of the vehicle, and a higher natural frequency. In Fig. 16, data for drop 11 is substituted for drop 12, since the drop 12 accelerometer failed; both drops were from the same height. The drop 12 displacement data (Fig. 17) shows that the paper honeycomb reduced the length of time the front suspension remained at maximum deflection and modified the suspension movements so the front and rear displacements were similar. Unfortunately, transducer malfunctions resulted in no rear displacement data for drops 10 and 15.

A summary of peak acceleration and displacement data is shown in Fig. 18. As with the jeep, the honeycomb substantially reduces peak accelerations over what would be expected without the honeycomb. This is also true with peak displacements. No damage was observed beyond the frame bending that occurred in drop 11. The vehicle started right up after the tests and operated normally in a driving test.

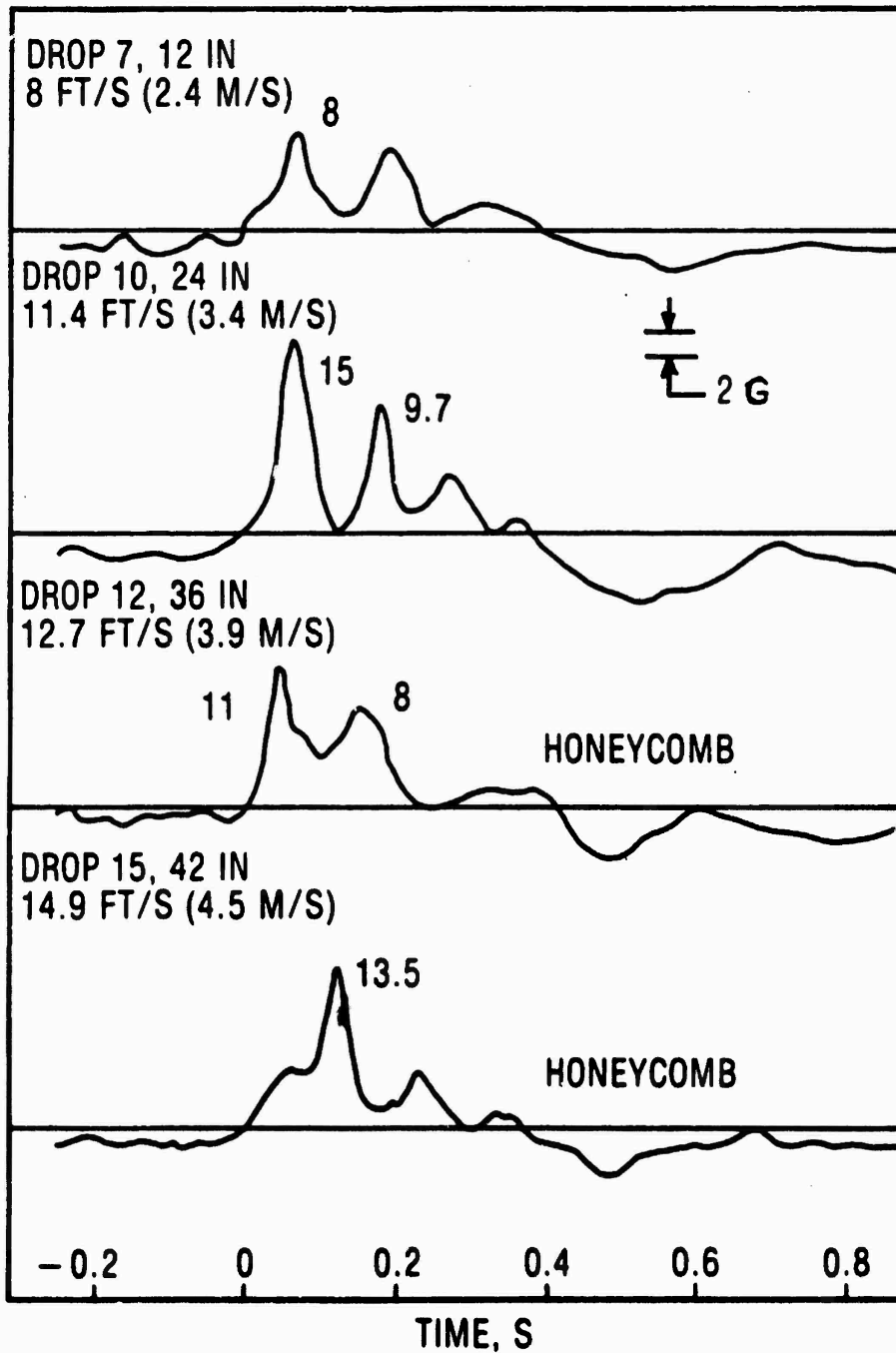

Figure 15. Acceleration time traces for M35 truck engine.

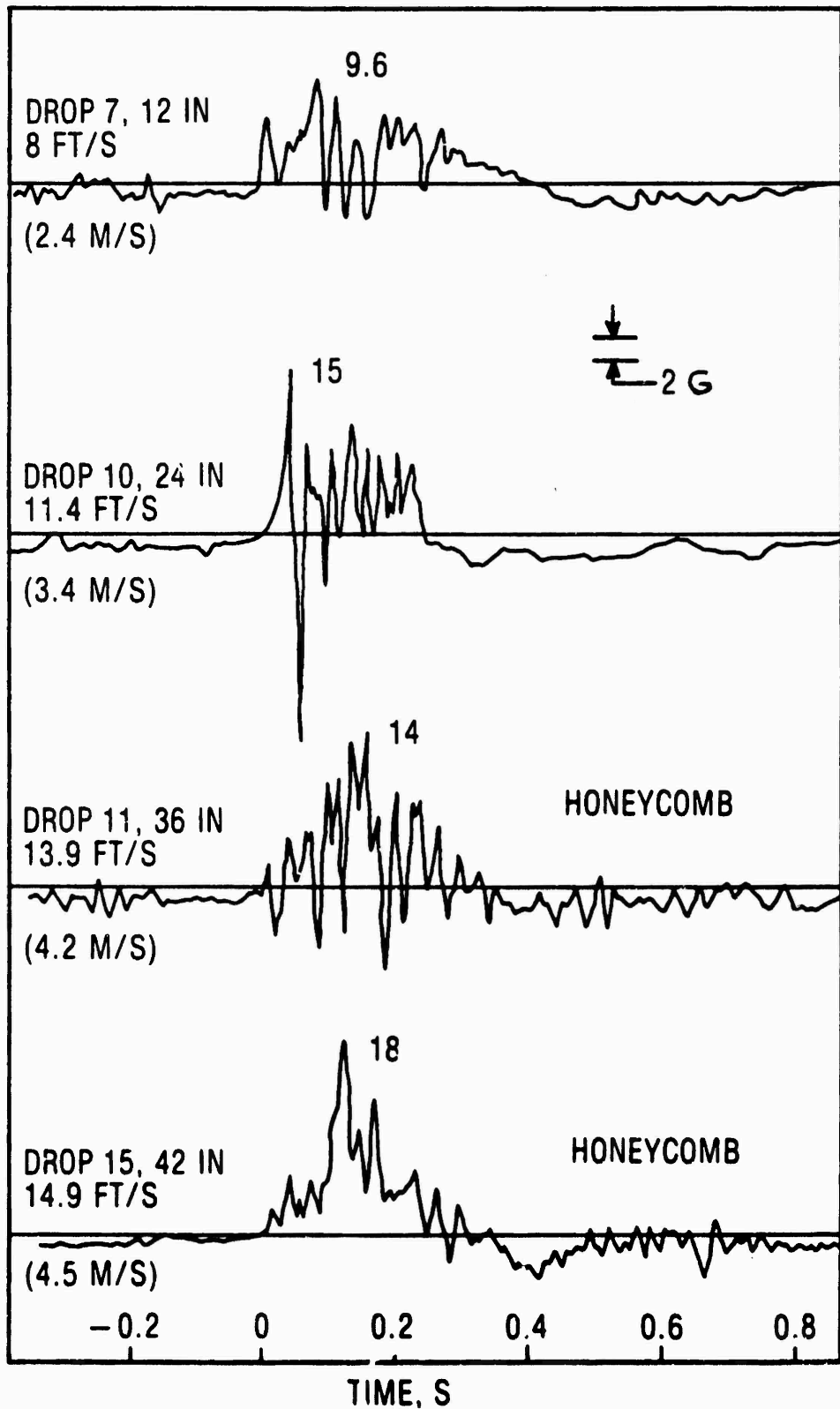

Figure 16. Acceleration-time traces for M35 truck center of gravity.

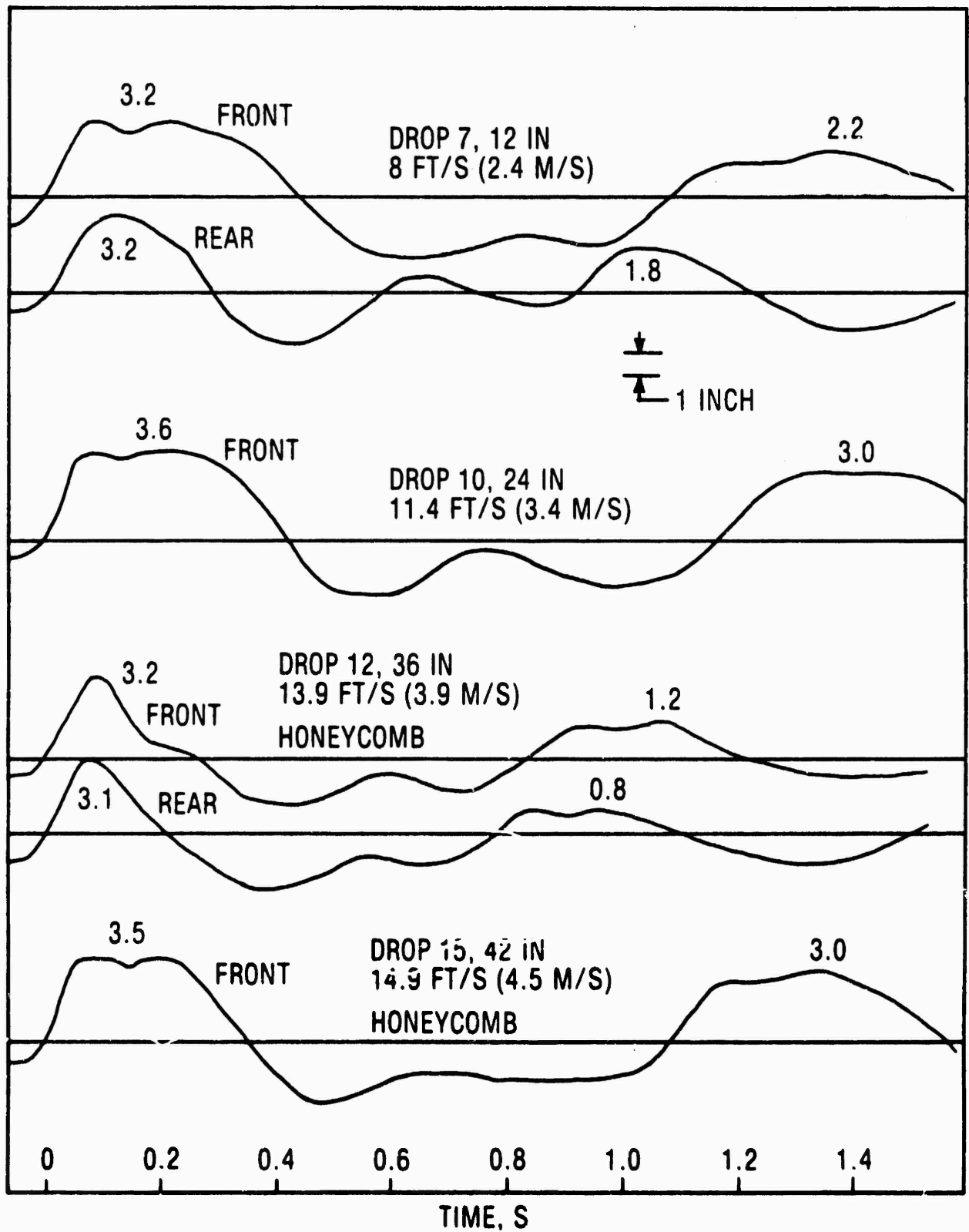

Figure 17. Displacement-time traces for M35 truck.



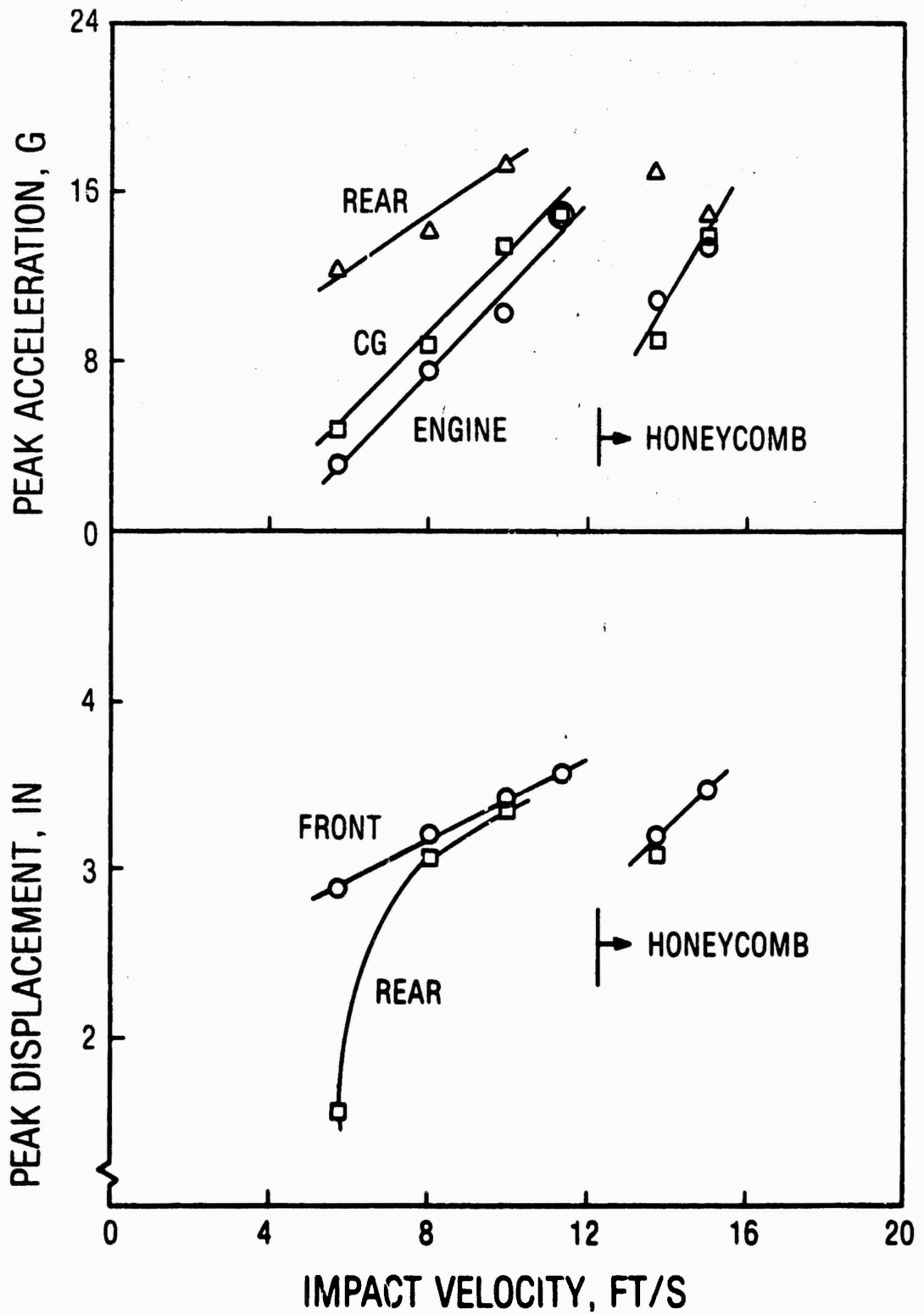

Figure 18. Peak displacement and acceleration vs. impact velocity for M 35 truck.

## Discussion

This study was not intended as a statistically accurate, comprehensive study of ultimate vehicle fragility, but rather an experimental determination of what impacts two typical military vehicles could withstand. No stresses or strains in load carrying members of either vehicle were measured, and fatigue was not considered. Actual impact-related physical damage was not used as a criterion for the upper limit of a soft or semisoft impact velocity; engineering judgement based on review of high-speed motion picture films and review of measured data was the criterion. It is possible the vehicles could withstand more severe impacts, both uncushioned and cushioned, than were determined in this report. The impact velocities determined in this report represent a good, conservative, engineering approximation to the soft and semisoft impact limits of these vehicles that can be used as baseline data in the concept and preliminary design of a soft/semisoft landing airdrop system.

The limitation that a 3/4-full fuel tank would put on impact velocity limits was not investigated here. For safety reasons, the fuel tank on the jeep was removed, and the tank on the 2 1/2-ton truck was drained so only about 1 inch (2.5 cm) of fuel remained in it. In the standard airdrop system, rigging manuals require that the fuel tanks be not more than 3/4 full. In standard full-honeycomb drops, the vehicle is decelerated at about 20 G and the fuel tank is usually unsupported; on some vehicles, additional support using webbing is specified. If the fuel tank can survive a 20-G deceleration in the present system, it can survive the 15 to 18 G peak decelerations measured in this study.

Securing the honeycomb stacks under the load is an area that needs more investigation. When the vehicle is supported by the suspension slings, the weight of the airdrop platform stretches the tie-downs, resulting in a gap between the honeycomb and the vehicle. Since the tie-down slings generally are at a considerable angle from vertical, and there is a limit to how much tension can be put on them, there is little hope of eliminating the gap. In the jeep drops a semi-crushed layer of polyurethane foam was used to fill the gap and spring-load the honeycomb, but installation was quite difficult. Other possibilities suggested here, but not tested or evaluated, are gluing the honeycomb to the platform, or developing a spring-ratchet, spacer mechanism that provides a spring force on the stack to hold it in place but has a ratcheting action to prevent compression of the device as the honeycomb crushes.

Uniformity of crush of the honeycomb stacks in pitched impacts of the jeep was no worse than in level impacts. In all jeep drops there was a tendency for stack buckling during crush since the side dimension was typically only 46% of the height. In the two jeep drops where the height of the stacks was reduced to 9 inches (23 cm), much more uniform crush resulted. This implies that a side dimension of at least 7 1/4 inches (18 cm) is needed on 12-inch (30-cm) stacks to promote uniform crush. No problems were encountered with stack buckling on the the 2 1/2-ton truck drops. The side dimension here was 15 inches (38 cm), and the tallest stack was 18 inches (46 cm).

No drops were performed with any horizontal velocity at impact. This is an added variable that should be investigated. It is rare in an actual airdrop to have impact occur with no horizontal velocity. It may be necessary to modify the standard tie-down sling arrangement to keep the load/platform shear to a minimum.

## CONCLUSIONS

The following conclusions are made as a result of this series of soft and semisoft landing tests:

1. Uncushioned impacts:

- a. The M151 jeep can withstand a 12.7-ft/s (3.9-m/s) impact velocity, equivalent to a 30-inch (76-cm) free fall; CG peak acceleration was 8 G.
- b. The M35 truck can withstand a 11.4-ft/s (3.5-m/s) impact velocity, equivalent to a 24-inch (61-cm) free fall, CG peak acceleration was 15 G.

2. Semicushioned impacts:

- a. The M151 jeep can withstand a 17.9-ft/s (5.5-m/s) impact velocity, equivalent to a 60-inch (152-cm) free fall; CG peak acceleration was 15 G .
- b. The M35 truck can withstand a 15.0-ft/s (4.6-m/s) impact velocity, equivalent to a 42-inch (107-cm) free fall; CG peak acceleration was 18 G .

3. The M35 truck must have honeycomb stacks under the middle area of the frame to prevent frame bending at impact velocities above 11.4 ft/s (3.5 m/s).

4. For drops where suspension slings are attached to the vehicle, some means of securing the honeycomb is needed.

This document reports research undertaken at the US Army Natick Research and Development Command and has been assigned No. NATICK/TR- 84/053 in the series of reports approved for publication.

LITERATURE CITED

1. Military Standard MIL-STD-669, Loading Environment and Related Requirements for Platform Rigged Airdrop Material, 9 August 1968.
2. Unpublished data: US Army Natick R&D Center Laboratory Notebook 7478, pp. 65-78, 1983
3. Military Specification MIL-H-9884D, Honeycomb Material, Cushioning, Paper, 26 November 1973

APPENDIX

DETERMINATION OF PAPER HONEYCOMB CRUSHING STRESS

The nominal crushing stress of paper honeycomb used in airdrop operations is  $6300 \pm 900 \text{ lb/ft}^2$  ( $302 \pm 43 \text{ kPa}$ ); this is specified in MIL-H-9884D, reference 3. In this specification, a dynamic crushing stress test is specified, and honeycomb lots are accepted only if the average dynamic crushing stress is within the range mentioned above. The sample size is 16 by 18 by 6 inches (41 by 46 by 15 cm). When a piece of honeycomb is cut to 5 1/2 by 5 1/2 inches (14 by 14 cm), the percentage of the area within an inch (2.5 cm) of the edge becomes substantial. Near the cut edge, little or no resistance to crush is provided by the cut honeycomb cell, and the adjacent cell is weakened. Also, in a stack that is 12 inches (30 cm) high, edge buckling may affect the uniformity of crush and may reduce the overall resisting force provided during crush. The result is a significantly reduced dynamic crushing stress.

Four tests were run on the dynamic impact testing machine here at Natick Research and Development Center; data is in Laboratory Notebook 7478, pages 95-96 (reference 2). For each test, four stacks of paper honeycomb each 5 1/2 by 5 1/2 by 12 inches (14 by 14 by 30 cm) were glued together and to a piece of plywood. The machine then crushed these samples at a velocity of 17 to 23 ft/s (5.2 to 7 m/s). An accelerometer and strain transducer on the input provided data from which a stress-strain graph was drawn.

The average dynamic crushing stress was  $3600 \text{ lb/ft}^2$  (172 kPa), or only 57% of the nominal value. A typical stress-strain curve is shown in Figure A-1.

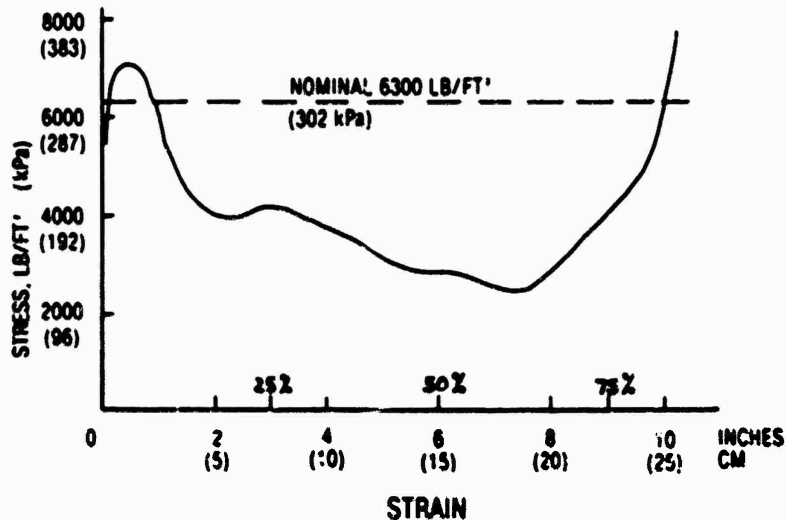

Figure A-1. Typical stress-strain curve for four 5-1/2 x 5-1/2 in x 12 in. (14 x 14 x 30 cm) paper honeycomb stack, impact velocity 23 ft/s (7 m/s).