

β (2)

NRL Memorandum Report 5587

Current Enhancement in a Conducting Channel

Y. Y. LAU, M. LAMPE, R. F. FERNSLER AND B. HUI

*Plasma Theory Branch
Plasma Physics Division*

AD-A155 418

May 30, 1985

This work is supported by the Defense Advanced Research Projects Agency under ARPA Order 4395, Amendment Number 41, and monitored by the Naval Surface Weapons Center.



DTIC
ELECTE
JUN 26 1985
S B D

DTIC FILE COPY

NAVAL RESEARCH LABORATORY
Washington, D.C.

Approved for public release; distribution unlimited.

85 06 13 130

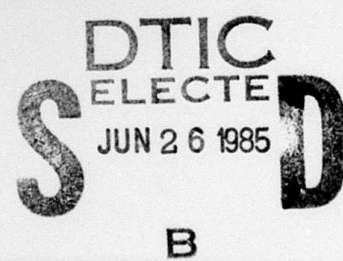
REPORT DOCUMENTATION PAGE				
1a REPORT SECURITY CLASSIFICATION UNCLASSIFIED		1b RESTRICTIVE MARKINGS		
2a SECURITY CLASSIFICATION AUTHORITY		3 DISTRIBUTION / AVAILABILITY OF REPORT		
2b DECLASSIFICATION / DOWNGRADING SCHEDULE		Approved for public release; distribution unlimited.		
4 PERFORMING ORGANIZATION REPORT NUMBER(S) NRL Memorandum Report 5587		5 MONITORING ORGANIZATION REPORT NUMBER(S)		
6a NAME OF PERFORMING ORGANIZATION Naval Research Laboratory	6b OFFICE SYMBOL (If applicable) Code 4792	7a NAME OF MONITORING ORGANIZATION Naval Surface Weapons Center		
6c ADDRESS (City, State, and ZIP Code) Washington, DC 20375-5000		7b ADDRESS (City, State, and ZIP Code) Silver Spring, MD 20910		
8a NAME OF FUNDING / SPONSORING ORGANIZATION DARPA	8b OFFICE SYMBOL (If applicable)	9 PROCUREMENT INSTRUMENT IDENTIFICATION NUMBER N60921-84-WR-W0131		
8c ADDRESS (City, State, and ZIP Code) Arlington, VA 22209		10 SOURCE OF FUNDING NUMBERS		
		PROGRAM ELEMENT NO 62707E	PROJECT NO	TASK NO
				WORK UNIT ACCESSION NO. DN680-415
11 TITLE (Include Security Classification) Current Enhancement in a Conducting Channel				
12 PERSONAL AUTHOR(S) Lau, Y.Y., Lampe, M., Fernsler, R.F. and Hui, B.				
13a. TYPE OF REPORT Interim	13b. TIME COVERED FROM 1984 TO 1985	14. DATE OF REPORT (Year, Month, Day) 1985 May 30	15. PAGE COUNT 13	
16 SUPPLEMENTARY NOTATION This work is supported by the Defense Advanced Research Projects Agency under ARPA Order 4395, Amendment Number 41, and monitored by the Naval Surface Weapons Center.				
17 COSATI CODES		18 SUBJECT TERMS (Continue on reverse if necessary and identify by block number)		
FIELD	GROUP	SUB-GROUP		
		Beam interaction in plasma		
		Conductivity, discharges		
19 ABSTRACT (Continue on reverse if necessary and identify by block number)				
<p>By the use of a simple model, we show that the transverse motion of a current-carrying filament in an electrically conducting medium may inductively produce a total current three times as large. An explanation of this phenomenon is given. The implications are explored.</p> <p style="text-align: right;">  </p>				
20 DISTRIBUTION / AVAILABILITY OF ABSTRACT <input checked="" type="checkbox"/> UNCLASSIFIED/UNLIMITED <input type="checkbox"/> SAME AS RPT. <input type="checkbox"/> DTIC USERS		21 ABSTRACT SECURITY CLASSIFICATION UNCLASSIFIED		
22a NAME OF RESPONSIBLE INDIVIDUAL Y. Y. Lau		22b TELEPHONE (Include Area Code) (202) 767-2765	22c OFFICE SYMBOL Code 4790	

CURRENT ENHANCEMENT IN A CONDUCTING CHANNEL

In a series of recent experiments,¹⁻³ it was observed that when a relativistic electron beam propagates in a gas (air, neon, or nitrogen) at about 100 torr, the net current is higher than, and at times almost twice as large as the beam current. This is remarkable as the plasma current generated by the beam ionization usually flows opposite to the beam. Concurrent with this current enhancement is detected a large amplitude hose motion of the electron beam. Several attempts have been made to explain this current enhancement.^{1,4} Our recent numerical simulations⁵ show that large amplitude hose motion can enhance the current up to eighty per cent, in reasonable agreement with experimental observations.¹⁻³

In this paper, we show that current enhancement is a general feature when a current source (electron beam) moves sideways inside an electrically conducting channel. Specifically, the present study indicates that the total current (the beam current and the induced current in the plasma) may be as much as three times the beam current when the beam reaches the conducting boundaries of the channel. These conclusions are valid as long as the channel conductivity is sufficiently high. They are a direct consequence of the Ampere-Faraday's Laws and appear to be relatively insensitive to the geometry of the channel. Following the presentation of our analysis of a highly simplified model, we provide an interpretation of this factor of three of current enhancement. The implications will be addressed but the details will be published elsewhere.

To illustrate the ideas, consider first a one-dimensional system. In our model, an infinitesimally thin current sheet, of surface density I_B , flows in the z -direction. This current sheet is initially located midway between two perfectly conducting plates, P_L and P_R , at $x = 0$ and $x = L$, respectively. We

Manuscript approved April 5, 1985.

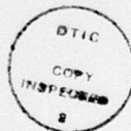

Dist	Special
A-1	

OR

assume that the medium between P_L and P_R is characterized by a constant electrical conductivity σ . We further assume that the current sheet has been situated at $x = x_B = L/2$ for a long time so that a steady state is already established at time $t = 0$, i.e., any plasma current has decayed to zero at $t = 0$. For $t \geq 0$, the current sheet is given a uniform x-ward motion, i.e., $x_B(t) = L/2 + ut$ where the speed u is assumed to be constant. In the following, we only consider the response of the magnetic fields to this transverse motion of I_B . We ignore the reaction on I_B , due to the resulting modification of the field profiles. Presumably this sideward motion is caused by some beam instabilities, or simply externally driven.

In terms of the vector potential $\vec{A} = \hat{z}A(x,t)$, the above system is governed by the diffusion equation

$$-\frac{c}{4\pi} \frac{\partial^2 A}{\partial x^2} = -\frac{\sigma}{c} \frac{\partial A}{\partial t} + I_b \delta(x - x_B(t)); \quad 0 < x < L, \quad 0 < t < L/2u \quad (1)$$

where c is the speed of light and δ is the Dirac delta function. Gaussian units are used and displacement currents are ignored. The boundary condition to Eq. (1) is $A(0,t) = A(L,t) = 0$, since P_L and P_R are perfect conductors. The initial condition to (1) is $A(x,0) = (\pi L I_B / c) (1 - |2x - L|/L)$ for $0 \leq x \leq L$, reflecting the assumption that a steady magnetic field is established prior to $t = 0$.

In terms of the vector potential \vec{A} , the (inductive) electric field $\vec{E} = -(c^{-1}) \partial \vec{A} / \partial t$ and the magnetic field $\vec{B} = \nabla \times \vec{A}$. Thus, the term $-(\sigma/c) \partial A / \partial t$ in Eq. (1) is the current density induced within the conductivity channel and the current enhancement factor F is given by $F(t) = 1 - (\sigma / I_b c) \int_0^L dx \partial A / \partial t$, which is the total current within the channel divided by the beam current.

The diffusion equation (1), together with its associated initial conditions and boundary conditions, may be solved by standard techniques. It can be shown that, in the limit $t \rightarrow \tau_t = L/2u$, (i.e., shortly before the current sheet makes contact with P_R) the current enhancement factor F is given by

$$F = 1 + \tanh\left(\frac{\pi v}{2}\right) + \frac{4}{\pi} \sum_{n=1, \text{ odd}}^{\infty} (-1)^{\frac{n-1}{2}} e^{-\frac{n^2 \pi}{2v} \frac{v^2}{n(n^2 + v^2)}} \quad (2)$$

where

$$v = \tau_d / \tau_t = 4u\sigma L / c^2 \quad (3)$$

is the ratio of the characteristic diffusion time $\tau_d = 2\sigma L^2 / c^2$ and the transit time $\tau_t = L/2u$. The infinite sum in Eq. (2), converges rapidly for finite values of v .

The enhancement factor F , as given by Eq. (2), is shown in Fig. 1 as a function of the normalized velocity v . Several features are noteworthy. Perhaps the most interesting one is that F approaches an asymptotic limit of three as v becomes large. From Fig. 1, one sees that $F > 2$ for $v \geq 1$. Thus, according to the present model, the total current within the channel exceeds twice the beam current the moment the current sheet strikes the plate P_R if $\tau_d > \tau_t$. For $v = \tau_d / \tau_t \leq 0.5$, a good approximation to F is $F \approx 1 + \pi v / 2$, as is readily verified from Eq. (2), and is also easily deduced from a quasi-static argument.

The asymptotic limit of three is quite unexpected. To gain insight into the physical processes, we show in Fig. 2 the evolution of F as a function of the normalized time t/τ_t , for various values of v . It is readily seen from

Fig. 2 that the current enhancement occurs mostly when x_B reaches within a "boundary layer" width of P_R . The width of this boundary layer (skin depth) is on the order of L/v , as suggested by Fig. 2. This may also be deduced by a dimensional argument from the diffusion equation (1).

The above phenomenon of current enhancement is also observed when we extend our model to two dimensions (e.g., a current carrying wire, situated inside a waveguide filled with conducting medium, is given a uniform transverse motion). Specifically, the maximum enhancement factor of three, as well as the presence of a boundary layer, is again obtained. Indeed, these features are of such a universal nature that they are independent of the initial location of the current wire (or current sheet for the one-dimensional problem), as long as $\tau_d \gg \tau_t$.

This asymptotic limit of three demands an explanation. To fix ideas, we return to the one-dimensional model described above. We let the speed u be finite and the channel conductivity σ be large (so that $v \propto \sigma u$ is large). The beam current always contributes one unit to the enhancement factor F , so it suffices to argue that the induced current contributes twice the beam current as the current sheet approaches P_R .

One unit of the induced current comes from the persistence of the initial magnetic field $\partial A(x,0)/\partial x$ which is already present at $t = 0$. The associated current distribution, which relaxes slowly in the limit $\tau_d \gg \tau_t$ is represented by J_A in Fig. 3. It is approximately gaussian in space. The total current associated with J_A is approximately equal to I_B since little of this initial magnetic energy is dissipated on the time scale τ_t if $\tau_d \gg \tau_t$.

The remaining unit of the induced current originates from the motion of current sheet. [This unit is independent of the initial $A(x,0)$, it therefore exists even in the hypothetical case $A(x,0) = 0$.] For uniform motion of the

current sheet, Eq. (1) admits a self-similar solution of the form $A_C(x,t) \propto f[x - x_B(t)]$. Such a solution A_C yields an induced current density given by

$$J_C(x,t) = \begin{cases} 0 & ; \quad x < x_B \\ - \left(\frac{\pi I_B v}{L}\right) e^{-\pi v(x-x_B)/L} & ; \quad x > x_B \end{cases} \quad (4)$$

which is sketched in Fig. 3. In physical terms, the movement x_B inductively drives a return current at the leading edge of x_B , as given by Eq. (4). However, $A_C(x,t)$, which gives rise to J_C , does not satisfy the boundary condition $A_C(L,t) = 0$. An image current source of the form $-I_B \delta\{x-[2L-x_B(t)]\}$ must be added to render the vector potential zero at $x = L$.⁶ Associated with this image is the current density

$$J_D(x,t) = \begin{cases} 0 & , \quad x > 2L - x_B \\ \left(\frac{\pi I_B v}{L}\right) e^{-\pi v(x - 2L + x_B)/L} & , \quad x < 2L - x_B \end{cases} \quad (5)$$

which is also sketched in Fig. 3. Summing up all contributions (J_A, J_B, J_C, J_D) between P_L and P_R , a current enhancement factor of 3 is then obtained as $x_B \rightarrow L$, since the contribution from J_C becomes negligibly small, while the contribution from J_D becomes significant. From Eqs. (4) and (5), as well as Fig. 3, it is clear why the current enhancement would occur within a boundary layer of width L/v of P_R when v is large, as shown in Fig. 2.

The above result has been based on idealized models. Nevertheless, the exposition of the basic physical processes enables us to give an assessment of more complicated situations. For example, if the electrical conductivity σ is highly concentrated only near the central region of the channel, (i.e., σ is small near the boundaries P_R and P_L), then only J_A and J_B would be the

dominant contributions as the current sheet (source) approaches P_R . In this case, an upper bound of $F \rightarrow 2$ is expected. As another example, if the motion of the current source is nonuniform, e.g., the current source is accelerated (decelerated) toward the wall P_R , a simple argument shows that the limiting value of F (Fig. 1) will be greater (smaller) than 3. We have also repeated our calculations with the displacement current term $(4\pi c)^{-1} \partial^2 A / \partial t^2$ included on the left-hand side of Eq. (1). We found that inclusion of the displacement current increases the enhancement factor F in general, but F does not exceed a value of 3.2 if $u/c \leq 0.3$ for the simplified model treated above.

Finally, we remark that Fig. 2 suggests the possibility of building a short pulse current amplifier, the maximum amplification being a factor of the order of three. From this figure, the pulse duration τ_p is on the order of $\tau_p = (1/v) \times L/2u = c^2/8u^2\sigma$. The transverse motion of the current may be provided mechanically or explosively. This process may also be viewed as one form of magnetic compression.

In conclusion, current enhancement takes place naturally when a current-carrying body undergoes transverse motion in a conducting medium. Especially large current enhancement may occur when this current moves to within a boundary layer thickness from the container. The recent experimental observations cited above may be just one of the many manifestations of this electromagnetic phenomenon. Indeed, because of the simplicity but surprising nature of these phenomena, one may well wonder whether this and related phenomena, in particular the limiting value of $F \approx 3$, have been noted elsewhere (e.g., geomagnetic dynamo, magnetohydrodynamic boundary layers, etc.).

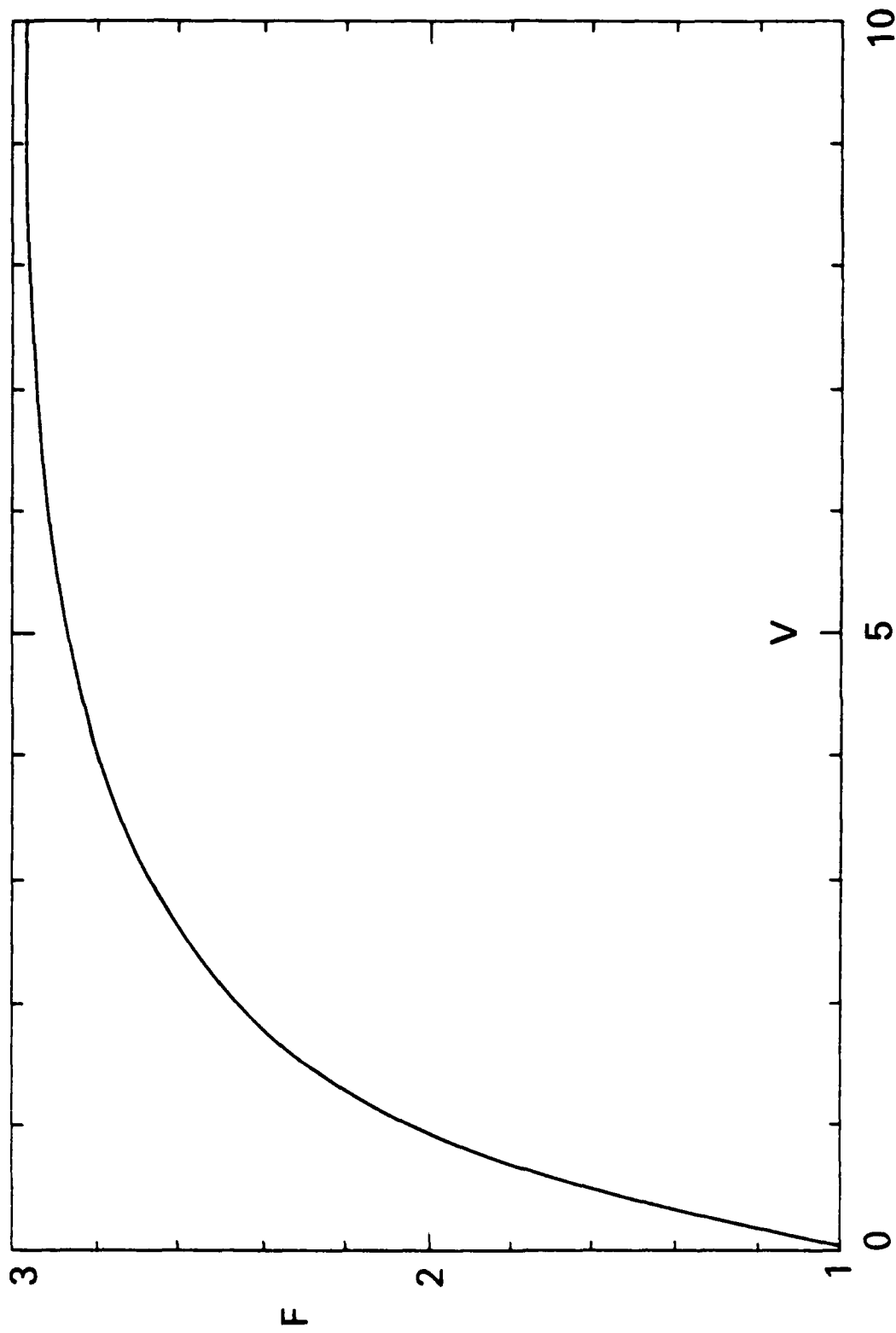

Fig. 1. The current enhancement factor F as a function of $v = \tau_d/\tau_t$, evaluated at the time when the moving current sheet is about to touch the conducting boundary.

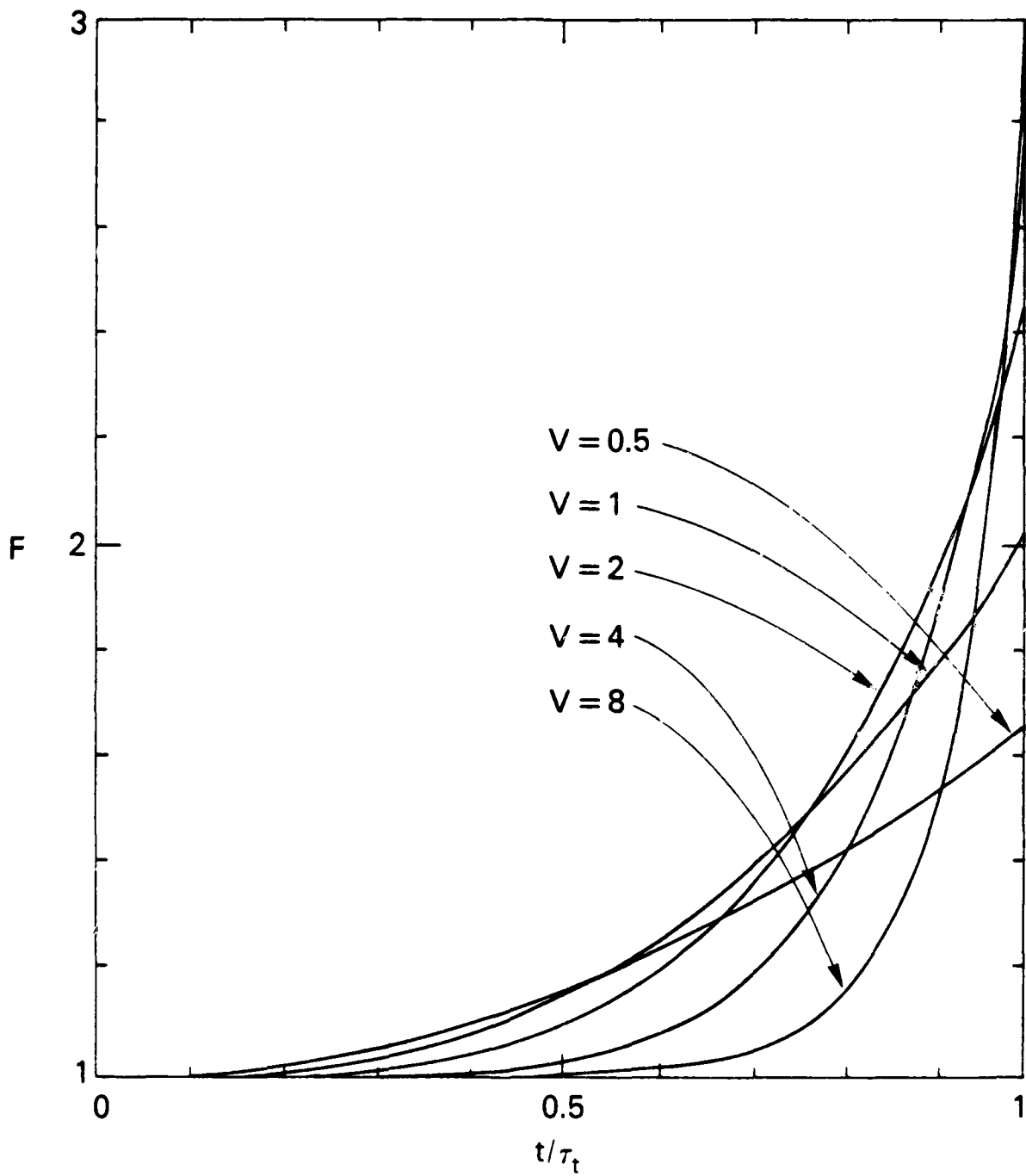

Fig. 2. Evolution of F for various parameters of v .

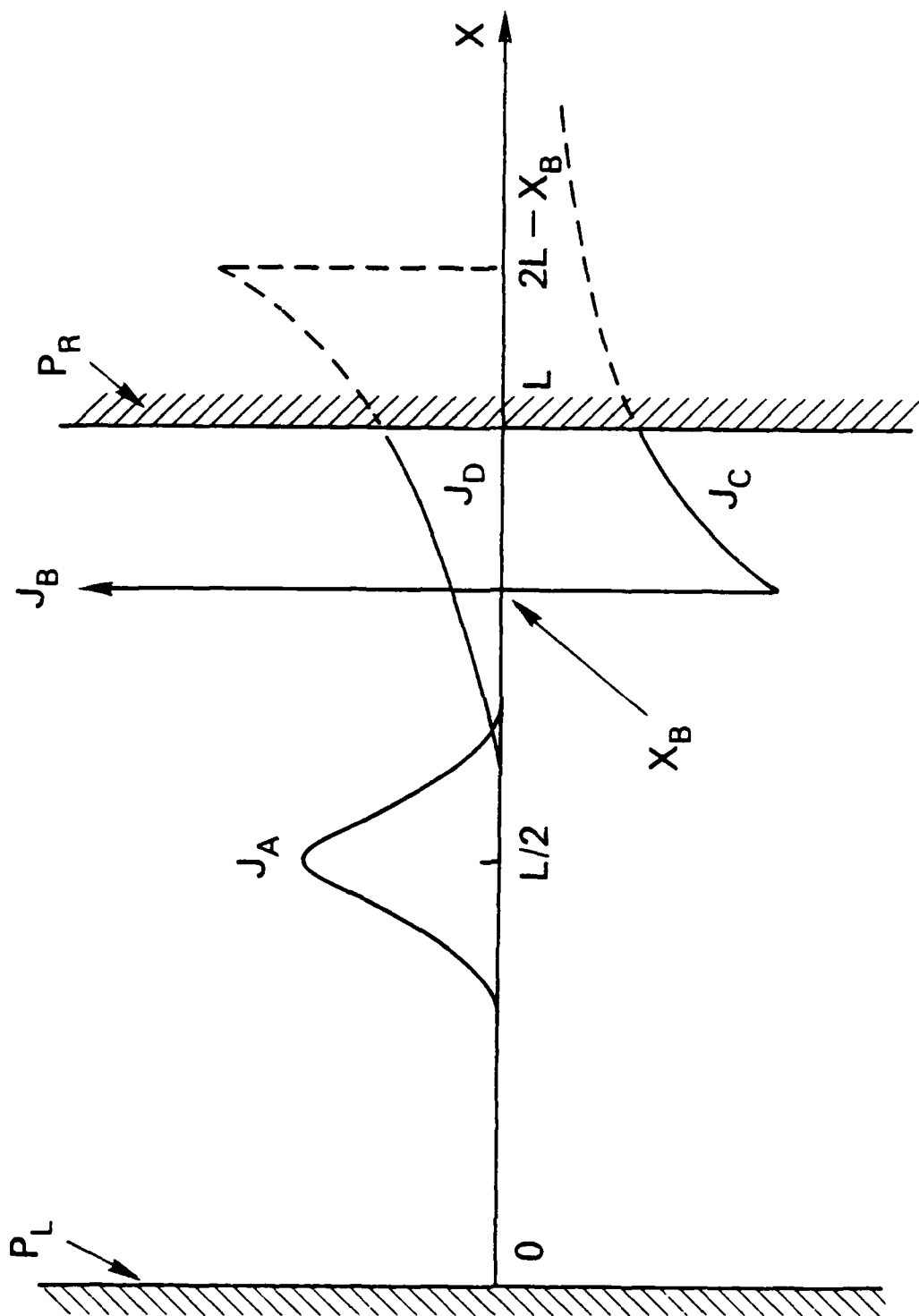

Fig. 3. The various contributions to the enhancement factor F (see text).

We thank G. Joyce and R. F. Hubbard for discussions on this work. This work is supported by DARPA, under ARPA Order 4395, Amendment Number 41, and monitored by Naval Surface Weapons Center.

References

1. J. C. Clark, K. W. Struve, S. S. Yu and R. E. Melendez, Proc. 5th Intl. Conf. on High Power Particle Beams, p. 412 (San Francisco, 1983).
2. J. C. Clark, E. J. Lauer, D. S. Prono and K. W. Struve, Lawrence Livermore National Laboratory Report No. UCID-20263 (1984).
3. F. W. Chambers, J. C. Clark, K. W. Struve and S. S. Yu, Lawrence Livermore National Laboratory Report No. UCID-90910 (1984).
4. S. S. Yu and R. E. Melendez, Lawrence Livermore National Laboratory Report No. UCID-19965 (1983).
5. B. Hui, R. F. Fernsler, M. Lampe, Y. Y. Lau, G. Joyce and R. F. Hubbard, submitted to Phys. Rev. Lett.
6. Strictly speaking, an infinite array of images is required if A is to satisfy the homogeneous boundary conditions at both $x = 0$ and $x = L$. However, it is quite clear that only the one included here can contribute significantly to F in the limit $\tau_d \gg \tau_t$, $t \rightarrow \tau_t$.

DEPARTMENT OF THE NAVY

NAVAL RESEARCH LABORATORY
Washington, D.C. 20375-5000

OFFICIAL BUSINESS
PENALTY FOR PRIVATE USE, \$300



POSTAGE AND FEES PAID
DEPARTMENT OF THE NAVY

DoD-316

THIRD CLASS MAIL

