

Report DAAK40-78-C-0272

# METHODOLOGY FOR UV CURED CONFORMAL COATING

AD-A151 972

John R. Fay and Edward A. Anderson  
Hughes Aircraft Company  
El Segundo, CA 90245

JUNE 1980

Final Report for Period 15 September 1978 - 15 June 1980

DTIC FILE COPY

Prepared for  
U.S. ARMY MISSILE RESEARCH AND DEVELOPMENT COMMAND  
Redstone Arsenal, AL 35809

ADVANCED SYSTEMS DEVELOPMENT AND MANUFACTURING TECHNOLOGY  
DIRECTORATE, DRDMI-EAA  
Redstone Arsenal, AL 35809

This document has been approved  
for public release and sale; its  
distribution is unlimited.

Best Available Copy

85 03 12 056

UNCLASSIFIED

SECURITY CLASSIFICATION OF THIS PAGE (When Data Entered)

REPORT DOCUMENTATION PAGE		READ INSTRUCTIONS BEFORE COMPLETING FORM
1. REPORT NUMBER	2. GOVT ACCESSION NO.	3. RECIPIENT'S CATALOG NUMBER
4. TITLE (and Subtitle) Methodology For UV Cured Conformal Coating		5. TYPE OF REPORT & PERIOD COVERED Final Report, 16 September 1978 to 15 June 1980
		6. PERFORMING ORG. REPORT NUMBER
7. AUTHOR(s) John R. Fay		8. CONTRACT OR GRANT NUMBER(s) DAAK40-78-C-0272
9. PERFORMING ORGANIZATION NAME AND ADDRESS Hughes Aircraft Company El Segundo, CA 90245		10. PROGRAM ELEMENT, PROJECT, TASK AREA & WORK UNIT NUMBERS
11. CONTROLLING OFFICE NAME AND ADDRESS U.S. Army Missile Research and Development Command, Redstone Arsenal, AL 35809		12. REPORT DATE June 1980
		13. NUMBER OF PAGES 17
14. MONITORING AGENCY NAME & ADDRESS (if different from Controlling Office) Guidance and Control Directorate DRDMI-EAT		15. SECURITY CLASS. (of this report) UNCLASSIFIED
		15a. DECLASSIFICATION DOWNGRADING SCHEDULE
16. DISTRIBUTION STATEMENT (of this Report)		
17. DISTRIBUTION STATEMENT (of the abstract entered in Block 20, if different from Report)		
18. SUPPLEMENTARY NOTES		
19. KEY WORDS (Continue on reverse side if necessary and identify by block number) Printed wiring board assemblies, insulating compound-electrical, ultra-violet curing, UV sensitive material, application and curing processes.		
20. ABSTRACT (Continue on reverse side if necessary and identify by block number) Printed wiring board assemblies coated with a newly developed UV sensitive material have met the applicable requirements of the Military Specification for Insulating Compound, Electrical MIL-I-46058. Material screening resulted in the development of this new material. A process for application by spraying, UV curing, and oven bake-out has been developed and documented (Continued)		

DD FORM 1473

UNCLASSIFIED

SECURITY CLASSIFICATION OF THIS PAGE (When Data Entered)

UNCLASSIFIED

SECURITY CLASSIFICATION OF THIS PAGE/When Date Entered:

20. ABSTRACT (Continued)

A cost/value analysis has been made and documented.

A high rate production facility has been specified and detailed and the supporting work flow diagram has been produced.

Production samples have been processed and delivered.

At the conclusion of the program, a debriefing session was held at Hughes, El Segundo. The data and results obtained in this program were passed on to the attendees and included all the information in this final report.

*Handwritten note:* See also Hughes, El Segundo, California

UNCLASSIFIED

SECURITY CLASSIFICATION OF THIS PAGE/When Date Entered

## PREFACE

This final report documents the results obtained during the Manufacturing Methods and Technology (MM&T) Program entitled "Methodology for UV Cured Conformal Coating."

This report was prepared by the Hughes Aircraft Company, El Segundo, California, under contract DAAK40-78-C-0272.

The effort was sponsored by U.S. Army Missile Research and Development Command (MIRADCOM).

The principal Hughes contributors were John Fay, Program Manager; Ed Anderson, Principal Investigator; J. Tull; R. Rawls; L. Long; R. Dunaetz; and H. Schwartz.

The work covered by this report was performed between 15 September 1978 and 15 June 1980.

*Little copy*

*11*

## CONTENTS

	<u>Page</u>
SUMMARY	1
Summary of Phase I Tasks	2
Summary of Phase II Tasks	3
Summary of Results and Conclusions	4
SECTION 1 - Background and Objectives	1-1
1. The Need for New PWB Conformal Coating Techniques	1-2
2. Objectives of the Manufacturing Methods and Technology Program	1-4
SECTION 2 - Phase I	2-1
Task 1. Materials Assessment and Selection of Candidate Material	2-2
Task 2. Process Evaluation and Optimization	2-14
Task 3. Projected Cos. Value Analysis	2-20
SECTION 3 - Phase II	3-1
Task 1. Production Facility Specified and Documented	3-2
Task 2. Delivery of Printed Wiring Boards	3-6
Task 3. Industry Debriefing Session Held	3-7
SECTION 4 - Conclusions and Recommendations	4-1
APPENDICES	
A. MIL-I-46058C Test Report - Hughes Technology Support Division	A-1
B. Fungus Resistance Test Report - Truesdail Laboratories	B-1
C. Thermal Humidity Aging Report No. 1 - Delsen Laboratories	C-1
D. 120 Day Hydrolytic Stability Test Results - Specimen Photograph	D-1
E. Thermal-Humidity Aging Report No. 2 - Delsen Laboratories	E-1
F. Existing Conformal Coating Process - Hughes Tucson	F-1
G. Existing Conformal Coating Process - Hughes SCG	G-1
H. Detailed UV Conformal Coating Process - Hughes SCG	H-1

## SUMMARY

Summary of Phase I Tasks

Summary of Phase II Tasks

Summary of Results and Conclusions

## SUMMARY OF PHASE I TASKS

- Materials assessment and selection of candidate materials
  - Industry survey
  - Material procurement
  - Material selection and preliminary testing
  
- Process evaluation and optimization
  - Qualification testing of materials
  - Documentation of processes
  
- Projected cost value analysis
  - Material costs
  - Comparison with existing conformal coating processes

A literature review of technical journals and a survey of 16 suppliers resulted in 35 candidate materials for initial testing. From the results of the initial tests, three material candidates were selected for qualification testing.

The Hughes Space and Communications Group (SCG) developed process for application and curing of the materials was documented. An attempt was made to qualify each material by testing a minimum of four sample specimens to the requirements of MIL-I-46058. Of the three material candidates, only one passed.

Data was obtained relative to the cost of coating printed wiring boards (PWBs), using the material that passed and the developed process for application and curing.

## SUMMARY OF PHASE II TASKS

- Production facility was specified and documented.
- Production type PWBs were processed and delivered.
- Industry debriefing sessions were held.

A production line capable of producing 750 PWBs in an 8 hour shift was specified and documented for the coating of PWBs, using the technology developed under this contract. Included was a process flow chart, production equipment specifications, and an assembly floor layout. Ten typical production-type PWBs were coated and cured in the Hughes SCG facility and delivered to MIRADCOM for their evaluation.

At the conclusion of the contract, two 1-day industry/government debriefing sessions were held at Hughes SCG in El Segundo, California. The attendees were briefed on the test data, results, and methodology established by this program.



## SUMMARY OF RESULTS AND CONCLUSIONS

- Material selection resulted in only one material, Hughson RD 3650-21, that met the objectives of a one part system, and passed the applicable MIL-I-46058C test requirements.
- The application process developed used spray coating and UV curing.
- The conclusions arrived at from this evaluation were:
  - UV cured conformal coating can be successfully utilized in production.
  - UV cured conformal coating has the potential to save production cost if the material used:
    - Is a single component ready-to-apply system
    - Does not require the addition of solvents
    - Cures in seconds, including obscured areas
  - There is no tangible cost reduction in materials and labor of the Hughson material versus the present conformal coating.

SECTION I  
BACKGROUND AND OBJECTIVES

1. The Need for New PWB Conformal Coating Techniques
2. Objectives of the Manufacturing Methods and Technology Program

## 1. THE NEED FOR NEW PWB CONFORMAL COATING TECHNIQUES

The methodologies presently used in industry for conformal coating of PWB assemblies need improvements or changes in order to reduce the possibility of mixing errors and accelerate the curing cycle to make it more cost effective. The application of ultraviolet (UV) cured conformal coatings on PWB assemblies can meet this requirement.

MIL-I-46058 is the specification for Insulating Compound, Electrical (For Coating PWB Assemblies). Use of existing qualified coating systems on PWB assemblies involves several disadvantages that UV cured conformal coating are expected to overcome. These disadvantages are:

- 1) Requires slow curing which takes hours of oven cure (or parylene batch deposition) cycles.
  - a) There is a strong possibility of contaminating coating during the curing operation
  - b) A program schedule delay is built in for the original coating and for any repair or rework operations that are needed
  - c) Allows coating to sag, providing minimal or no coverage over sharp contours on the PWB assembly (i.e., trimmed component leads, flatpack lead edges, and capacitor edges)
  - d) requires expensive parylene batch deposition
- 2) Usually requires mixing of two (or more) part formulated coating systems.
  - a) Adds another manufacturing technician labor increment to the coating process
  - b) Offers the possibility of a mixing error
- 3) Usually requires solvent systems (thinners) to lower the viscosity of the resin system for ease of application and to allow tailoring of the formulation.
  - a) Normally requires explosion-proof exhaust systems. Also, local ordinances may limit the amount of solvent vapors which can be exhausted into the surrounding plant environment. This could:
    - (1) Curtail the volume of hardware coated per hour
    - (2) Necessitate a change in type of solvent system used

UV cured coatings as specified for this study required no mixing of components or catalysts by the user, UV cured in seconds, and were usually solvent-free systems. The potential elimination of mixing steps and rapid curing make the UV cured coating process more desirable than conventional MIL-I-46058 coatings due to potential decrease of rework and scrap, and enhanced possibility of using high speed, conveyORIZED, and semiautomated processing.

This Manufacturing Methods and Technology (MM&T) Program was conducted to

- Evaluate and qualify UV conformal coating material candidates
- Optimize conformal coating processing of PWBs
- Define a production line capable of coating and curing 750 PWBs in an 8-hour work day.

## 2. OBJECTIVE OF THE MANUFACTURING METHODS AND TECHNOLOGY PROGRAM

The program was devoted to the evaluation, selection and qualification of materials suitable for coating (PWBs) using UV curing. The resultant PWBs coated with these materials must meet the requirements of MIL-I-46058 to be considered as qualified.

Hughes SCG was awarded a contract for an MM&T Program on UV Cured Conformal Coating of Printed Wiring Boards. The contract ran from September 1978 to June 1980 and consisted of two major phases.

### Phase I

- Material screening and selection
- Process evaluation and development
- Cost/value analysis

### Phase II

- Production line specification
- Two-day industry/government demonstration
- Delivery of ten typical PWB assemblies

Phase I (20 months) was a material and process evaluation effort with the goal of selecting and qualifying materials suitable for the conformal coating of PWBs using UV curing. The PWBs coated by these prototype processes were to result in an acceptable end-product (defined as meeting requirements of MIL-I-46058). The UV conformal coating process was to have reliability, good producibility, and be competitive in cost with normal conformal coating processes. The technology also was to be readily adaptable to current PWB production systems building U.S. Army hardware, with minimal conversion costs.

In Phase II (6 months), the objective was to specify a production line using the optimized process developed in Phase I. Finally, a government/industry debriefing session was to be held wherein the results of this program would be disseminated to government and industry representatives at two 1-day sessions.

SECTION 2

PHASE I

- Task 1. Materials Assessment and Selection of Candidate Materials
- Task 2. Process Evaluation and Optimization
- Task 3. Projected Cost/Value Analysis

## TASK 1. MATERIALS ASSESSMENT AND SELECTION OF CANDIDATE MATERIALS

UV coating suppliers were contacted to obtain coating samples already formulated and ready for direct application (see Table I). These suppliers either submitted materials for testing (Figure 1) or declined for various reasons.

Screening of candidate materials continued through June, 1979. Approximately 30 candidate materials were screened during this period. The preliminary tests were chosen to weed out unsatisfactory candidates with a minimum of testing expenditures.

The initial testing resulted in the identification of two coating materials which were fast curing, had few processing problems, and had the potential of meeting MIL-I-46058C requirements (see Table II). The first was W. R. Grace's NB XRCP-10526-51-1, and the second was De Soto's DeSolite 2353-7 with about 5 percent benzoyl peroxide (BP) catalyst (Lucidol's Luperco ATC) mixed into it just before coating application.

Some processing problems were encountered with these two materials. The Grace material had too high an initial viscosity (the cured coating thickness was about 0.016 inch). After about 2 months, it started gelling in its metal container. The De Soto coating required that BP be added just before applying it to the PWB. De Soto did not send their 2353-7 with the BP in it because of the possibility it might greatly shorten the shelf life of the material (i.e., it would cure in its shipping container before it could be evaluated). The De Soto material with BP in it cured more slowly than the Grace material, requiring twice the UV and thermal exposure time. Neither of these cured coating exhibited the required ultraviolet fluorescence.

During the selection period, five materials and modifications of two additional materials were chosen for additional screening. Table III summarizes the results of this screening. Applications of the coating by spraying and by dipping were attempted. From these tests, three coatings, applied by spray and by dipping, were deemed satisfactory to be subjected to MIL-I-46058 qualification testing. These were De Soto 2353-7 (+BP), Grace 9332 (A&B) and Hughson RD 3650-21.

The decision was made to submit samples of each of the three materials, applied by spraying, for MIL-I-46058 qualification testing. Table IV summarizes the characteristics of the materials chosen.

In October 1979, all the tests required under MIL-I-46058 were completed for three candidate materials (Hughson RD 3650-21, Grace 9332 (A&B), and De Soto 2353-7). A summary of the results is shown in Table V. The Grace 9332 (A&B) and De Soto 2353-7 materials were considered failures, since neither passed the thermal humidity aging test (Appendix A) or the fungus tests (Appendix B). As a result of these failures, the 6 month shelf life tests for these two candidates were cancelled. The results of the Q resonance tests are displayed with no pass-fail judgement added. This is because the candidate materials, which fall into either the acrylated polyurethane (De Soto and Hughson), or polyene-thiol (Grace) class, do not fall in any of the existing classes of materials noted in MIL-I-46058 (acrylic resin, epoxy resin, silicone resin, polyurethane resin or paraxylylene).

TABLE I. UV COATING MATERIAL SUPPLIER CONTACT LIST

Company Name	Candidates Supplied	Contact	Telephone No.
W.R. Grace	11	Charles Morgan	(301) 531-5711
		Dick Bush	(301) 531-4000
De Soto	6	John Krajewski	(312) 391-9441
		Wally Brown	(312) 391-9203
Hughson	4	Jim Fonda	(814) 868-3611
Du Pont	3	John Wood	(215) 896-2358
Conchemco	2	Jim Fischer	(213) 222-5111
Dynachem	2	Larry Ernster	(714) 551-6101
3M	1	Jack Deviny	(612) 733-6995
Celanese	1	Ken Zeliznak	(201) 273-6600
Lilly Industries	1	Bill Richardsor.	(317) 634-8512
Mac Dermid	1	Bill Adams	(203) 754-6161
Thiokol	1	Betsy Peterson	(609) 396-4001
B. F. Goodrich	0	Gary Koch	(213) 386-7436
ICI America	0	Joe Lombardo	(302) 575-8422
Inmont	0	Bernie Howard	(513) 841-6100
UVEXS	0	Allan Puder	(408) 737-2760



FIGURE 1. COATING SAMPLES (PHOTO 79-80643)



TABLE II. UV CURED COATING MATERIALS CONDENSED TEST SUMMARY CHART (U.S. ARMY CONTRACT)

Activity	Coating Type				Thiokol ZM894
	Grace NBXRCP-10526-51-1	De Soto 2353-7 (+BP)	Grace NBXRCP-10526-51-2	Celzone Formula 25605-30C	
Cure					
Under resistors	Yes	Yes	Yes	No	No
Surface	Yes	Yes	Yes	Yes	Yes
Initial electrical insulation resistance, ohms	>20 x 10 <sup>12</sup>	>20 x 10 <sup>12</sup>	2.0 x 10 <sup>12</sup>	2.8 x 10 <sup>12</sup>	Not run
Thickness, in.	0.016	0.006	0.013	0.005	0.032
Cure method	Horizontal; 1 scan + 5 min in 200°F oven	Horizontal; 2 scans + 10 min in 200°F oven	Horizontal; 1 scan + 5 min in 200°F oven	Horizontal; 1 scan + 5 min in 200°F oven	Vertical; 1 scan + 5 min in 200°F oven
Application method	Dip	Dip	Dip	Dip	Dip
Appearance	Clear, uneven (wavy), no black light response	Clear, some pinholing, no black light response	Clear, wavy, no black light response	Bubbles in cured coating, clear, no black light response	Bubbles in cured coating, clear, no black light response
Comments	Gelled in can (probably due to unfiltered light exposure); initial viscosity too high; subsequently installed room light filters	BP added at time of use. Requires 5/100 BP to cure it. Slower curing than Grace system. Shelf life tests to be run with BP in it	Initial viscosity too high, cannot spray properly, excessive bubbles trapped in cured coating	Ingredients mixed at time of use; excessive bubbles trapped in mix	About 2 years old sample; high initial viscosity

TABLE II. UV CURED COATING MATERIALS CONDENSED TEST SUMMARY CHART (U.S. ARMY CONTRACT)  
(Continued)

Activity	Coating Type				Grace RCC 15D
	Conchenco 817 C-301	Conchenco 817 C-301	Dyachem/Thiokol Base 3/Sensitizer 1	Dyachem/Thiokol RD 7/Sensitizer 1	
Cure	No	No	No	No	No
Under resistors Surface	Yes	No	Yes	Yes	Yes
Initial electrical resistivity, ohms	Not run	Not run	Not run	Not run	Not run
Thickness, in.	0.002	0.008	0.005	0.004	0.007
Cure method	Vertical; 1 scan + 5 min in 200°F oven	Horizontal; 1 scan + 5 min in 200°F oven	Horizontal; 1 scan + 5 min in 200°F oven	Horizontal; 1 scan + 5 min in 200°F oven	Horizontal; 1 scan + 5 min in 200°F oven
Application method	Dip	Dip	Dip	Dip	Dip
Appearance	Clear, no black light response	Clear, no black light response	Clear, no black light response	Cured coating cracked, amber, no black light response	Bubbles on back of board, clear, no black light response
Comments	-	-	Ingredients mixed at time of use; 20/1 (Base 3 to sensitizer 1)	Ingredients mixed at time of use; 20/1 (RD 7 to sensitizer 1)	About 2 years old sample; high initial viscosity

TABLE III. UV CURED COATING SYSTEMS TESTED; JANUARY -- JUNE 1979

Activity	Coating Type			
	Racco 01109-1	Hughison RD 3420-73	De Soto 2353-7 (+BP)	De Soto 2353-7 (+BP)
Application method	Dip	Spray	Spray	Spray
Cure	No	No	Yes	Yes
Under resistors	Yes	Yes	Yes	Yes
Exposed surface	Not run	3.6 x 10 <sup>12</sup>	>20 x 10 <sup>12</sup>	>20 x 10 <sup>12</sup>
Insulation resistance, ohms	Not run	Not run	Not run	Not run
Initial	Not run	Not run	Not run	Not run
1 hr after cycle*	Not run	Not run	Not run	Not run
24 hr after cycle*	Not run	Not run	Not run	Not run
Thickness, in.	0.005	0.003	0.001	0.001
Cure method	Horizontal; 2 scans + 15 min in 200°F oven	Horizontal; 2 scans + 15 min in 200°F oven	Horizontal; 2 scans + 15 min in 200°F oven	Horizontal; 2 scans + 15 min in 200°F oven
Appearance	Coating yellowed after thermal cure; no black light response	Orange peel, bubbles; no black light response	Has black light response	Has no black light response
Flex test	Not run	Cracked across bend	No cracks at bend	No cracks at bend
Comments	Initial viscosity too high to spray	No thinner needed to spray apply	100 ml resin + 35 ml toluene + 0.2% Tracer-Tec 704/80 (125 cps viscosity), slight surface tack	100 ml resin + 40 ml acetate + 0.2% anthracene; slight surface tack

\* Temperature-humidity tests run per MIL-STD 202 Method 106, 10-day cycle. Exception: insulation resistance readings taken before (initial), 1 hour, and 24 hours after test.

TABLE III. UV CURED COATING SYSTEMS TESTED: JANUARY - JUNE 1979 (Continued)

Activity	Coating Type		
	Grace 932A	Grace 9332 (A+B) (Old Cure)	Grace 9332 (A+B) (Old Cure)
Application method	Spray	Dip	Spray
Cure			
Under resistors	Not run	Yes	Yes
Exposed surfaces	Yes	Yes	Yes
Insulation resistance, ohms			
Initial	> 1 x 10 <sup>16</sup>	> 1 x 10 <sup>16</sup>	> 1 x 10 <sup>16</sup>
1 hr after cycle*	Not run	1.6 x 10 <sup>11</sup>	3.5 x 10 <sup>12</sup>
24 hr after cycle*	Not run	2 x 10 <sup>15</sup>	1 x 10 <sup>15</sup>
Thickness, in.	0.002	0.007	0.002
Cure method	Horizontal; 1 scan + 200°F oven for 10 min	Horizontal; 1 scan + 200°F oven for 10 min	Horizontal; 1 scan + 200°F oven for 10 min
Appearance	Lower boiling temperature solvents blistered off metal surfaces; fillers gave milk white coloration	Smooth, clear	Smooth, clear
Flex test	Cracked across bend	No cracks at bend	No cracks at bend
Comments	Thinning with reactive diluents or using 20% by weight talc or Hydrid 710 resulted in failing flex test; undiluted 9332A viscosity approximately 24,000 CPS, no shelf life stability	Has black light response; three part system**	Has black light response; three part system**

\* Temperature humidity tests run per MIL STD 202 Method 106, 10-day cycle. Exception: insulation resistance readings taken before (initial), 1 hour, and 24 hours after test.

\*\* Three parts - Blend B is dissolved in acetone, then added to Blend A.

TABLE IV. UV CURED COATING SYSTEMS SELECTED FOR MIL-I-46058 QUALIFICATION;  
ONLY SPRAY SAMPLES BEING TESTED

Activity	Coating Type				
	Hughson RD 3650-21	Hughson RD 3650-21	Grace 9332 (A+B) (New Cure)	Grace 9332 (A+B) (New Cure)	De Soto 2353-7 (+BP)
Application method	Dip	Spray	Dip	Spray	Dip
Cure					Spray
Under resistors	Yes	Yes	Yes	Yes	Yes
Exposed surface	Yes	Yes	Yes	Yes	Yes
Insulation resistance, ohms					
Initial	>1 x 10 <sup>16</sup>	>1 x 10 <sup>16</sup>	>1 x 10 <sup>16</sup>	>1 x 10 <sup>16</sup>	>1 x 10 <sup>16</sup>
1 hr after cycle*	1.3 x 10 <sup>15</sup>	1.4 x 10 <sup>15</sup>	7.8 x 10 <sup>14</sup>	7.3 x 10 <sup>14</sup>	>4 x 10 <sup>15</sup>
24 hr after cycle*	1.6 x 10 <sup>15</sup>	3.0 x 10 <sup>15</sup>	2.4 x 10 <sup>15</sup>	1.9 x 10 <sup>15</sup>	2 x 10 <sup>15</sup>
Thickness, in.	0.002	0.001	0.002	0.002	0.002
Cure method	Horizontal; 2 scan + 200°F oven for 15 min	Horizontal; 2 scan + 200°F oven for 15 min	Horizontal; 2 scan + 200°F oven for 15 min	Horizontal; 2 scan + 200°F oven for 15 min	Horizontal; 2 scan + 200°F oven for 20 min
Appearance	Wavy; few small craters; clear	Very slight orange peel on on back; clear	Smooth, clear	Smooth, clear	Smooth, clear
Flex test	No cracks at bend	No cracks at bend	No cracks at bend	No cracks at bend	No cracks at bend
Comments	Has black light response; one part system	Has black light response; one part system	Has black light response; three part system**	Has black light response; three part system**	Has black light response; two part system (add 5% BP to resin)

\* Temperature-humidity tests run per MIL-STD 202 Method 106 10-day cycle. Exception: insulation resistance readings taken before (initial),  
1 hour, and 24 hours after test.

\*\* Three parts - Blend B is dissolved in acetone, then added to Blend A.

TABLE V. MIL I 46050 TEST RESULT SUMMARY FOR UV CURED COATING CANDIDATES

Examination of Test	Coating Specimen Test Results	
	Hughson RD 3650-21	De Soto 2353-7 (+BP)
<b>GROUP I</b>		Grace 9332 A/B
Cure time and temperature	Interpress Scan Series 720-1 200 watt/inch mercury arc lamp, low intensity, scan speed 69 inch/minute, followed by 25 minute dwell in a 200°F air circulating oven	
Appearance	Passed	Passed
Coating thickness	Passed (0.001 in.)	Passed (0.001 in.)
Fungus resistance	Passed	Failed (growth noted after 21 days)
<b>GROUP II</b>		
Shelf life	Passed	Not tested*
Appearance	Passed (1.4 x 10 <sup>15</sup> ohm)	Not tested*
Insulation resistance	Passed (0.77 μA)	Not tested*
Dielectric withstanding voltage		
<b>GROUP III</b>		
Q (resonance)		
Percent change in Q before and after coating	10.1	26.7
1 MHz	18.4	7.6
50 MHz	9.1	27.3
100 MHz		
Percent change in Q before and after 24 hr immersion in water		
1 MHz	16.3	40.8
50 MHz	5.9	37.0
100 MHz	5.9	3.9
Thermal shock		
Appearance	Passed	Passed
Dielectric withstanding voltage	Passed (0.50 μA)	Passed (0.51 μA)
		Passed (0.49 μA)

\*Will not be tested since samples failed fungus resistance and thermal humidity aging, hydrolytic stability.

TABLE V. MIL I 4605B TEST RESULT SUMMARY FOR UV CURED COATING CANDIDATES (Continued)

Examination or Test	Coating Specimen Test Results		
	Hughson RD 3650-21	Grace 9132 A/B	De Soto 2353-7 (VBP)
<b>GROUP IV</b>			
Appearance	Passed	Passed	Passed
Insulation resistance	Passed (3.2 x 10 <sup>15</sup> ohm)	Passed (3.8 x 10 <sup>15</sup> )	Passed (3.5 x 10 <sup>15</sup> )
Moisture resistance	Passed	Passed	Passed
Appearance	2.6 x 10 <sup>10</sup> avg	1.8 x 10 <sup>9</sup> avg	7.6 x 10 <sup>9</sup> avg
Insulation resistance (at 10 cycles)	1.6 x 10 <sup>10</sup> min	5.0 x 10 <sup>8</sup> min	5.9 x 10 <sup>9</sup> min
Average and minimum lowest value during cycles, ohms	Passed (0.58 μA)	Passed (0.79 μA)	Passed (0.76 μA)
Dielectric withstanding voltage	Passed	Passed	Passed
<b>GROUP V</b>			
Flexibility	Passed	Passed	Passed
<b>GROUP VI</b>			
Thermal humidity aging	Passed (slight shade change, resistor markings legible, no corrosion)	Failed (after 56 days: complete reversion, resistor alpha-numeric markings illegible and missing, color change, severe metal corrosion)	Failed (after 56 days: coating fractured, resistor alpha-numeric markings illegible and missing, metal corrosion, slight shade change)
<b>GROUP VII</b>			
Flame resistance	Passed	Passed	Passed

After the thermal humidity aging test, Hughson RD 3650-21 on the test boards appeared to have a light orange shade. It was agreed at the time of the oral report at MIRADCOM in October 1979 that it would be desirable to determine whether the coating or the board had changed shade by rerunning the thermal humidity aging test.

While preparing for this additional testing, three new candidate materials, Grace XRCP 432C, De Soto 2633-115-1 (+BP), and 3M L-4637 (a cationic epoxy system), were received, evaluated, and passed initial testing (see Table VI).

The second thermal humidity aging test was conducted from January through May 1980 with an uncoated board used as a control. In addition to the uncoated board, and boards coated with the previously tested Hughson RD 3650-21 material, samples coated with three new candidate materials were included in the test. Boards coated with Hughes SCG material (HP 16-170, Type I) an adaptation of Uralane 5750 (M&T Chemicals Co.) conformal coating, was added as a control. This coating is routinely used at Hughes to coat spacecraft production boards. Each type of coating specimen (three), plus a bare laminate, were placed in their own separate container to minimize the chance of contamination from the degradation of another coating. In the initial thermal humidity aging test, all samples were run in a single dessicator which could possibly have caused cross-contamination of test samples.

The results of this test indicated that shade changes during the test period occur in the coating, since no shade changes were observed in the bare laminates (see Appendix A). No reversion, softening, chalking, blistering, cracking, tackiness, or loss of adhesion or liquefaction of either the Hughson coating or two of the three new candidate materials was observed.

The 3M material samples showed evidence of liquefaction as exhibited by flow patterns (a nonuniform sag of the coating caused by gravity) across the specimen. The coatings were also slightly tacky to the touch (see Appendix C).



TABLE VI. UV CURED COATING CONDENSED TEST SUMMARY CHART (U.S. ARMY CONTRACT)

Activity	Coating Type				
	Grace XHCP 432C	De Soto 2633-115-1 (+8P)	Hughson RD 3050-21	3M L-4637	HP16-170 Type I (Modified Uralane 5750)
Cure					
Under resistors Surface	Yes Yes	Yes Yes	Yes Yes	Yes Yes	Conventional coat- ing not applicable
Initial electrical resistivity, ohms	1.0 x 10 <sup>15</sup> Beckman L-8	1.0 x 10 <sup>15</sup> Beckman L-8	1.0 x 10 <sup>15</sup> Beckman L-8	1.0 x 10 <sup>15</sup> Beckman L-8	1.0 x 10 <sup>15</sup> Beckman L-8
Thickness, in.	0.0015	0.0008	0.0010	0.0015	0.0110
Cure method	Horizontal; 1 scan/ width plus 4 hrs in 200°F oven	Horizontal; 1 scan/ width plus 25 mins in 200°F oven	Horizontal; 1 scan/ width plus 25 mins in 200°F oven	Horizontal; 1 scan/ width plus 4 hrs in 200°F oven	4 hr 130°F first coat; overnight ambient + 200°F 4 hr second coat
Application method	Spray	Spray	Spray	Spray	Spray first coat; pour second coat
Appearance	Occasional clusters of small bubbles; glossy clear coating	Occasional clusters of small bubbles; slightly clear coat	Slight orange peel effect	Some small bubbles	Small craters
Flex test	Pass	Pass (-2 material failed)	Pass	Pass	Pass
Comments	3 part system, heat part 2 to 130°F; pour into part 1 then dissolve in 1, 1, 1 trichloroethane. Thin fastener with IPA, 50R/5T/3 IPA. Soak bolts in IPA; air blast dry with gun. 30 min air dry before UV cure.	2 part system; add butyl acetate 7 parts to 100 parts resin -- add 1% Grace Tech 704/80 5 phw BP (Lacindol's Lupercio ATC).	1 part system, add 27 g butyl acetate to 100 g resin.	4 part system, Ref. letter 12/3/79 E.J. Deviny. 10 phw L4637, 10 phw base resin, 1 phw flexibilizing resin, 0.5 phw L4638, 2 phw MIBK.	2 part kit. First coat 50 g 5750B, 9 g 5750A, 17 drops 1% Thermolite 12. Second coat, hand mix all ingredients.

## TASK 2. PROCESS EVALUATION AND OPTIMIZATION

A complete process for application, curing and testing PWBs, using UV conformal coating, has been developed (see Appendix A).

### Application

Dipping was the first method used to apply the coating to the PWBs. The evaluation was successfully redirected toward the use of spray application for the following reasons:

- 1) Dip application usually requires more equipment (holding racks, holding fixtures, tanks, conveyors, circulation devices), results in more coating material waste (coating holding fixtures, as well as PWB assemblies, and run or dripoff losses), and requires more cleanup after coating, than does spray application.
- 2) Since the UV coating material would be inside a container during spraying operations, instead of in an open tank as during dipping operations, there should be the ability to spray under existing incandescent or fluorescent lighting (UV spectrum emission filtering in production areas may not be required).
- 3) Implementation of the spray process for UV would entail only minor changes to the evaluated existing Hughes facility for coating PWBs.

After thinning each material to approximately 175 centipoise, material was applied with a Binks model 26 spray gun with a 785 nozzle. With the air pressure between 30 and 40 psi, the gun was held about 6 inches from the board and the box coat applied (see Figure 2).

### Curing

#### Equipment

The UV curing equipment used for this Program was Interpress Corp., Model BP 720-1 SPL scan series (see Figure 3). This equipment was used because it was already in existence at Hughes SCG, and has built-in features to protect electronic hardware to prevent component overtemperature, electrostatic discharge, and scanning lamp interference. This curing equipment is set up in the Hughes SCG Digital Electronics Production Area near the existing PWB conformal coating and UV cured marking ink process areas. UV curing parameters for the oven were selected based on previous experience with UV cured ink marking presently used to identify electronic assembly hardware at Hughes SCG.

#### Tooling

Horizontal and vertical holding fixtures were fabricated. The horizontal holding fixture (HOFX) (see Figure 4), was selected so that the coated board surface could be placed in the focal plane of the lamp. Although some cure occurs with a vertical HOFX, a coating slump to the lower edge of the board occurs and the focal plane is compromised, resulting in lack of uniform cure.

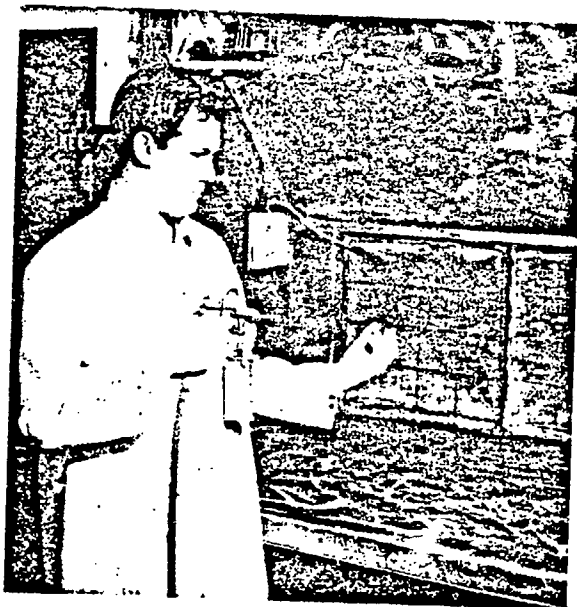

00216.2

a) SPRAYING AREA (PHOTO 80-85010)

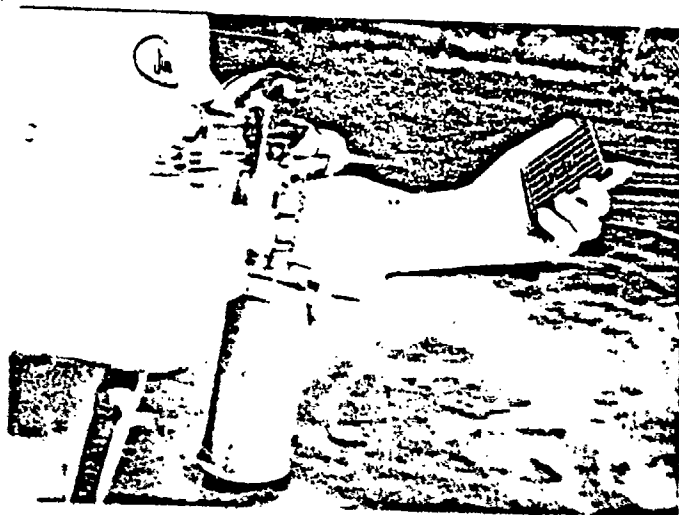

00216.3

b) SPRAYING TECHNIQUE (PHOTO 80-85011)

FIGURE 2. UV COAT SPRAY OPERATION

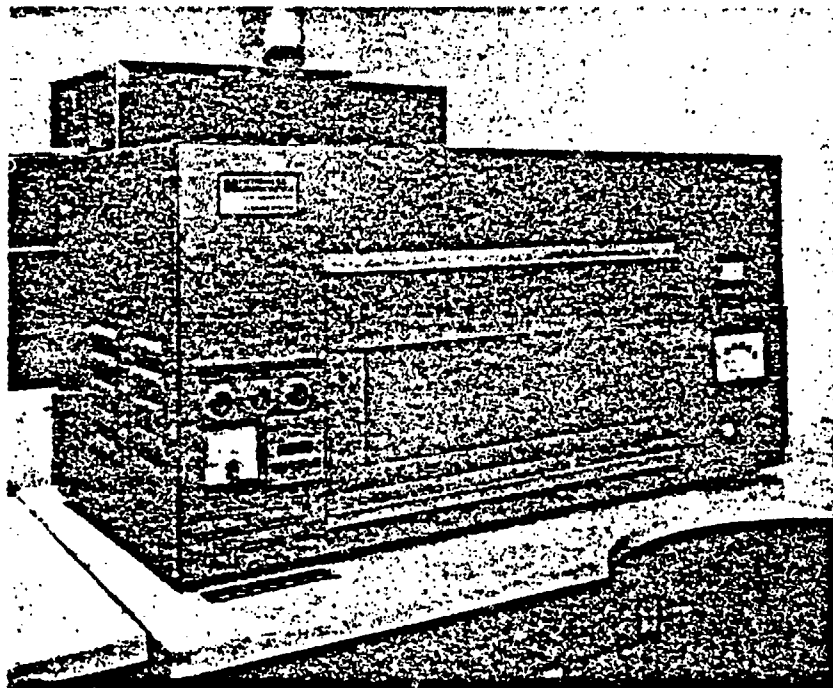

00216-4

a) DOOR CLOSED

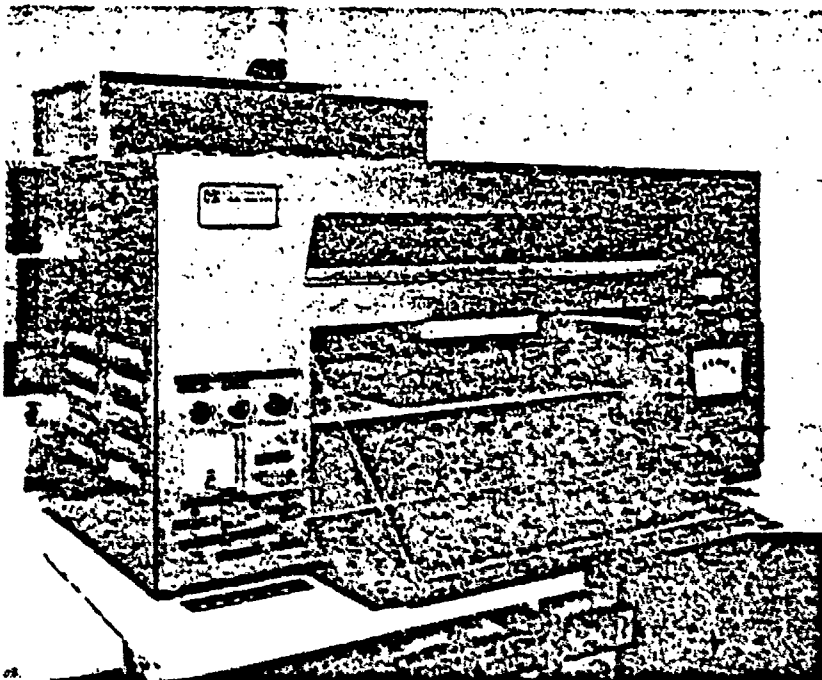

00216-5

b) DOOR OPEN

FIGURE 3. ULTRAVIOLET CURING OVEN

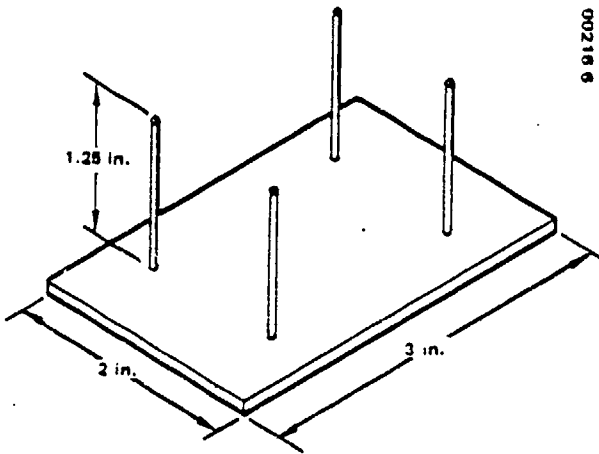

00216 6

FIGURE 4. HORIZONTAL HOLDING FIXTURE

## Testing

### Cure Test Boards

The cure test boards (see Figure 5) were 2 by 3 inch pieces cut from Circuit-Stik GP C8102 boards with two groups of three, side-by-side, 0.25 inch long by 0.09 inch diameter, carbon resistors soldered to the board sections. The lower surface of the resistors were mounted to stand about 0.05 inch off the board. This area was hand filled with candidate material to simulate a maximum filleting condition under the components. To check the cure of coating in shadowed areas, the leads on one side of one group of resistors were cut after UV exposure and the resistors peeled back to see if there was uncured coating material under them. This was determined by probing in the fillet, and by finger touch. After the secondary thermal exposure, the leads of the second set of resistors were cut and the resistors peeled back. The completeness of coating surface cure was checked by rubbing with a dry Q-tip and by touch.

### Insulation Resistance

Y pattern test boards, with about 2 inch long standard electrical insulated wires soldered to them (similar to the boards called out in MIL-I-46058), were isopropyl alcohol scrubbed, Ajax scrubbed, deionized water rinsed, and oven dried for 2 hours at 200°F. They were then electrically tested at room temperature with a Model 1863 General Radio Megohmmeter. All the boards produced resistance readings greater than  $20 \times 10^{12}$  ohms. This was a preliminary screening test, since the meter's next-to-last division is at  $20 \times 10^{12}$  ohms, and the last division is infinity. The boards were then coated and UV cured and the insulation resistance was measured again.

### Coating Thickness Measurements

Cured coating thickness measurements were taken using a micrometer on both the cure test boards and the insulation resistance test boards.

### Appearance Observations

Visual observations were made, usually without magnification, for such items as bubbles, transparency, color, and cracking using fluorescent lamp room lighting.

The coating was checked to see if fluorescence was exhibited when viewed under UV illumination using a Black-Ray Model B-100A (Ultra-Violet Products Inc., San Gabriel, CA) longwave UV lamp unit.

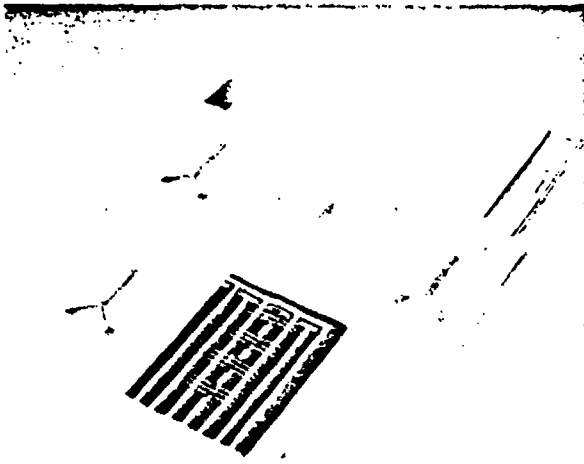
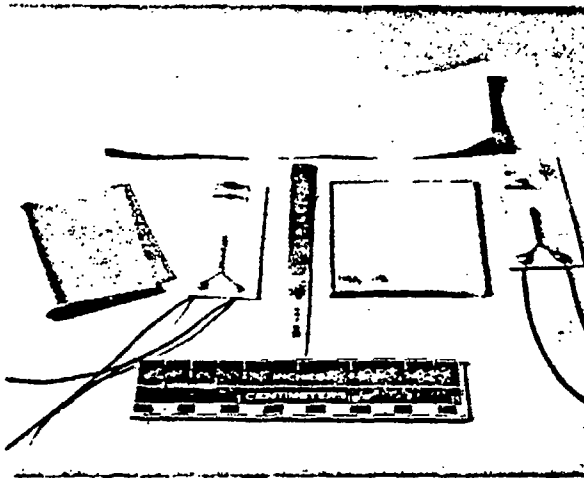

FIGURE 5. CURE TEST BOARDS (PHOTOS 80-88122 AND 80-88567)

### TASK 3. PROJECTED COST/VALUE ANALYSIS

An analysis of the material costs to conformally coat a typical PWB using the spray application method was performed. The Hughson material was the only material that passed all the applicable MIL-I-46058 tests, and was, therefore, the only material priced. A comparison was made between the coating costs using a CONAP Conathane kit applied per Hughes specification HP 16-119 (see Appendix D) versus the Hughson Chemical UV curing material. No cost advantage was determined for either system. Results and calculations are shown in Table VII.

It is noted, however, that nonquantifiable advantages may be gained from sprayable UV cured coatings qualified subsequent to this Program, such as:

- No component mixing (excess material can be reused)
- Usually solvent free
- Initial cure in seconds, including obscured areas

The savings that accrue are from the elimination of mixing and ease of handling.

TABLE VII. MATERIAL COST ANALYSIS

Material	Cost/Gallon, dollar	No. PWBs Coated	Cost/Board, dollar
CONAP Conathane Kit	43.10*	130	0.33
Hughson Chemical RD 3650-21 70% at \$51.85 = \$36.30			
Butyl acetate 30% at \$27.73 = \$ 8.31			
Total cost <u>\$44.61</u>	44.61**	137	0.33

Source: \*Hughes Tucson pricing  
 \*\*Vendor verbal quote  
 (Telecon)



SECTION 3

PHASE II

- Task 1. Production Facility Specified and Documented
- Task 2. Delivery of Printed Wiring Boards
- Task 3. Industry Debriefing Session Held

## TASK 1. PRODUCTION FACILITY SPECIFIED AND DOCUMENTED

A production facility capable of producing 750 typical PWB assemblies per 8 hour work day was specified. A survey was made of two of the principal Hughes groups manufacturing military electronics systems containing PWBs. These were Hughes Missile Systems (Tucson) and Hughes Electro Optical and Data Systems (El Segundo).

Personnel contacted at Hughes Missile Systems were Tom Sutherland and Bob Knorr. Contacted at Hughes Electro Optical and Data Systems (EODS) were Earl Holst and Bill C. De Baca. These persons are knowledgeable and actively involved in conformal coating processing of PWBs. The specified facility contains a series of batch-run automated and semiautomated processing machines. This concept, rather than a fully automated system, was chosen because of high initial implementation cost requirements, and to minimize production losses due to individual machine outage.

Table VIII lists the materials and equipment required. Figure 6 is the work flow diagram and Figure 7 shows the facility layout. Figures 8 through 11 are photographs showing the individual equipment.

TABLE VIII. PROPOSED UV PWB COATING MATERIAL AND EQUIPMENT REQUIREMENTS

Material/Equipment	No. Req'd	Cost \$K	Model	Solvent
Automatic cleaner	1	40	Electro Kleen System: 2004 In-Line Solvent Cleaner; EKS-503 Auxiliary Solvent Cleaner; 7.5AF Insta Chill, with stands, variable height load mod- ule, DIGI-LOK controller, and automatic refill system	Trichloroethane
Zicon automatic coater	1	40	Hughson Chemical Part No. 3650-21	Butyl acetate or equivalent
UV cure system	1	20	Screen Printing Enterprises UV Reactor Model 3PI-303 (modified) or equivalent	
Bake out oven	1	19	Spectra IR Model or equivalent	
On-line inspection	1	5	Conveyor-Black Light	
Fume scrubber and venting	1	10		
Total cost		134		

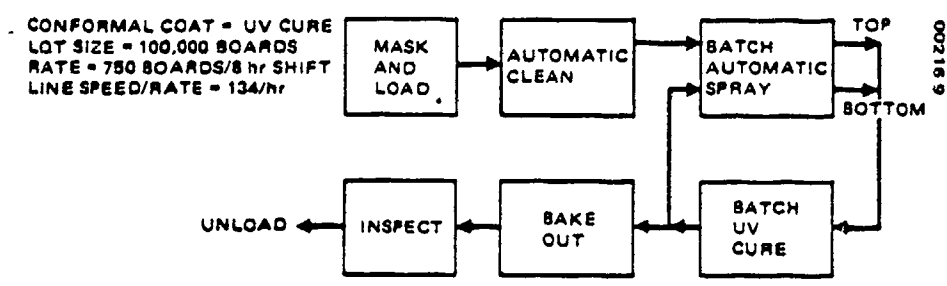

FIGURE 6. PROPOSED UV PWB COATING WORK FLOW DIAGRAM

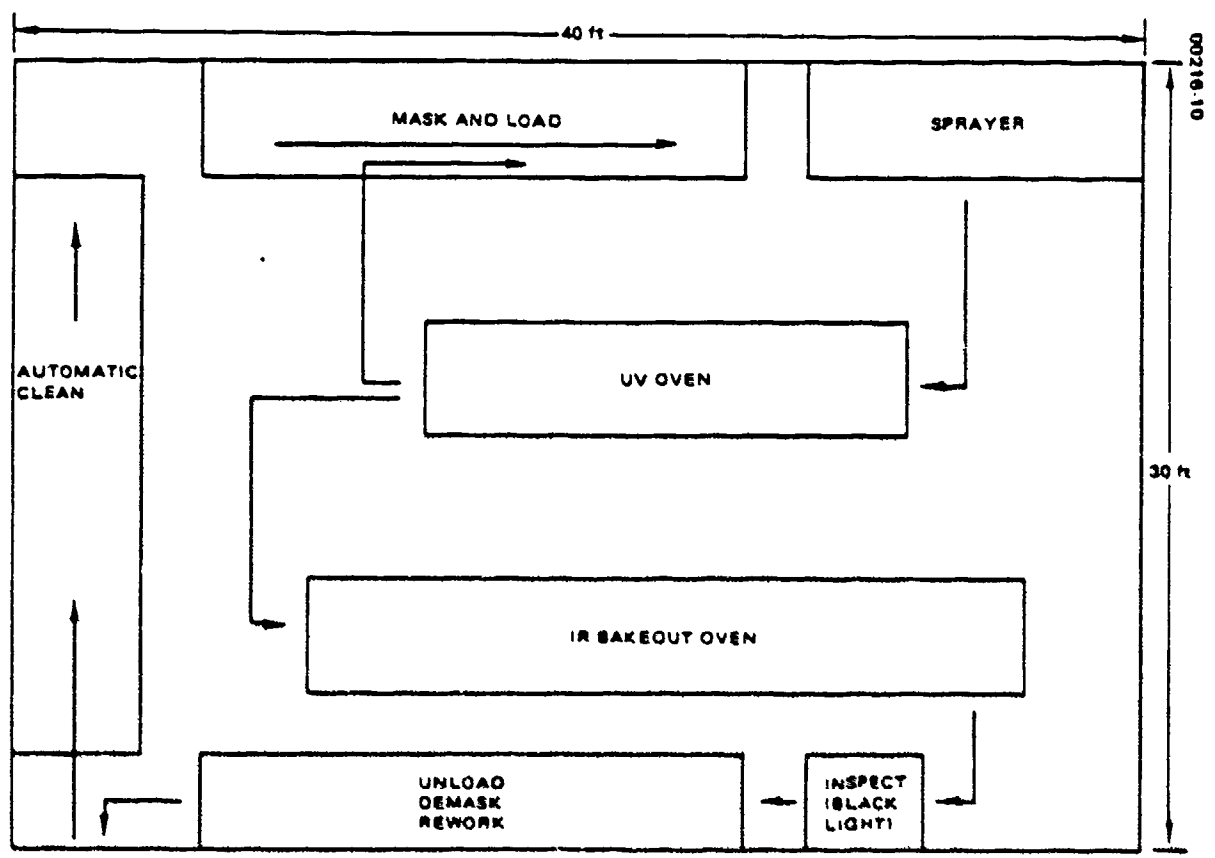

FIGURE 7. PROPOSED UV PWB COATING FACILITY LAYOUT

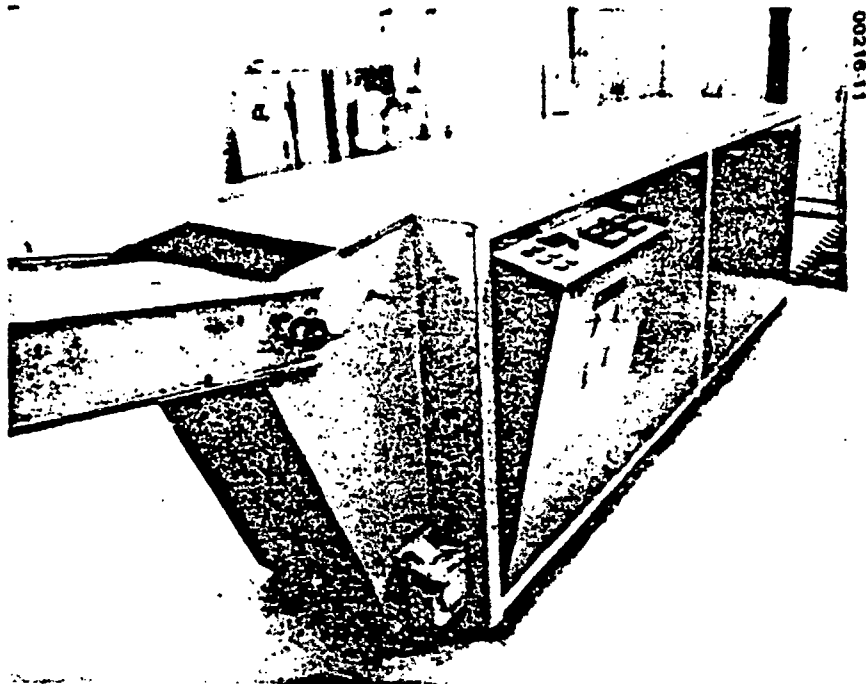

FIGURE 8. AUTOMATIC CLEANER (HUGHES EODS)

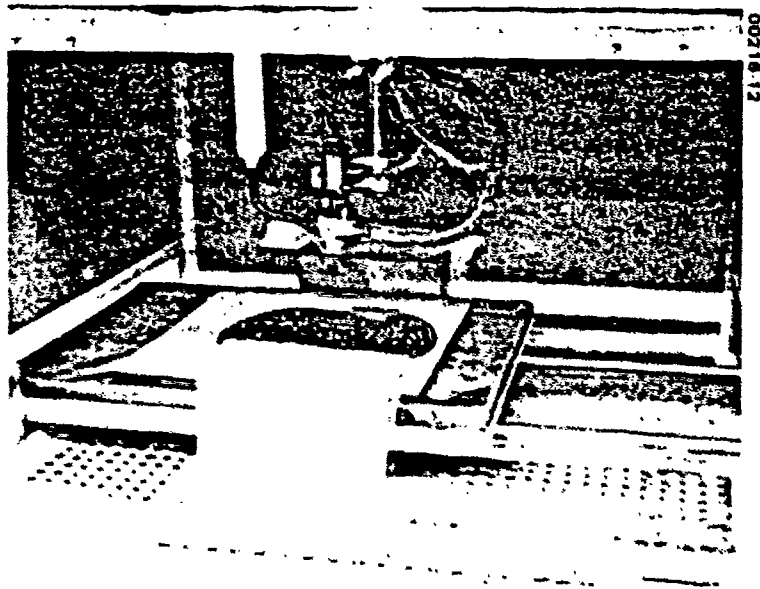
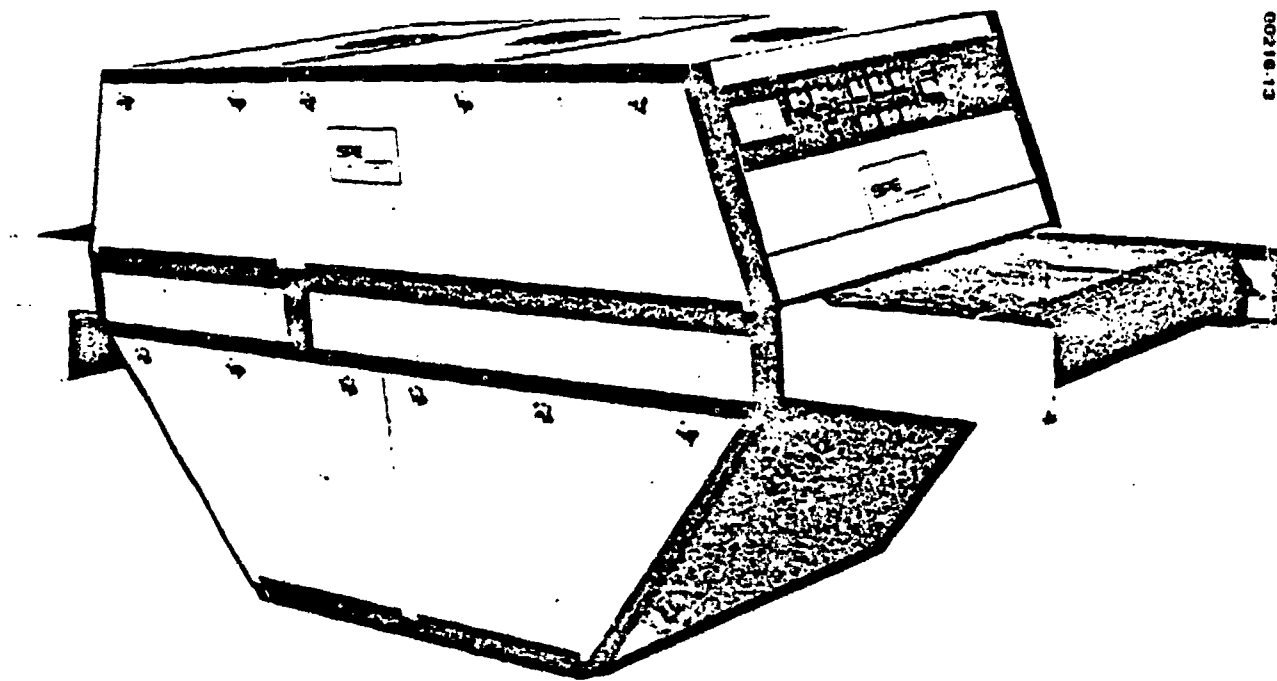
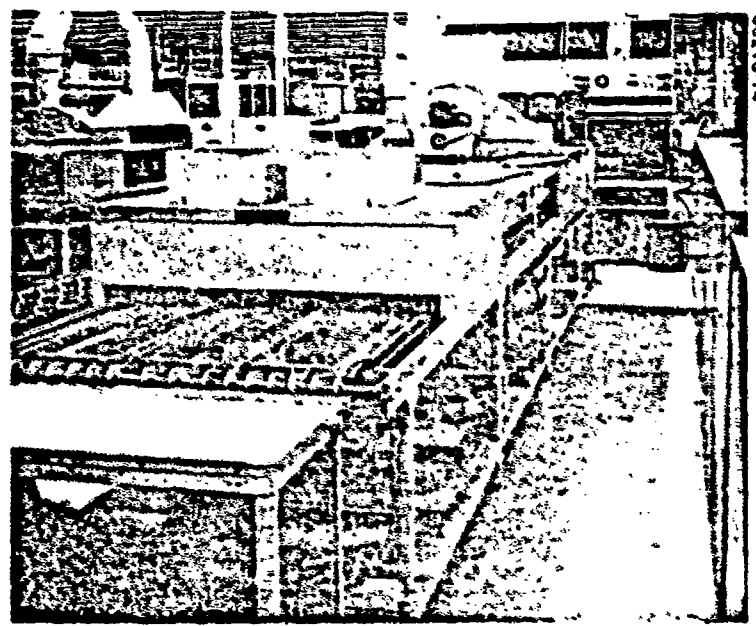

FIGURE 9. AUTOMATIC COATER (HUGHES TUCSON)



00218-13

FIGURE 10. ULTRAVIOLET REACTOR



00218-14

FIGURE 11. BAKE OUT OVEN (HUGHES TUCSON)

## TASK 2. DELIVERY OF PRINTED WIRING BOARDS

Ten production type PWBs, Hughes Part No. 867218, were processed with UV conformal coating (Hughson) and delivered to the customer (see Figure 12).

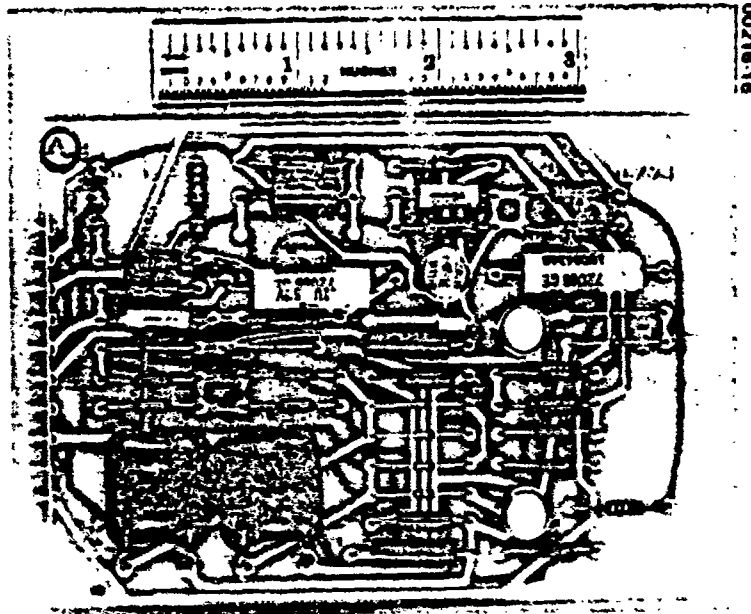

00218-18

a) TOP VIEW (PHOTO 79-83783)

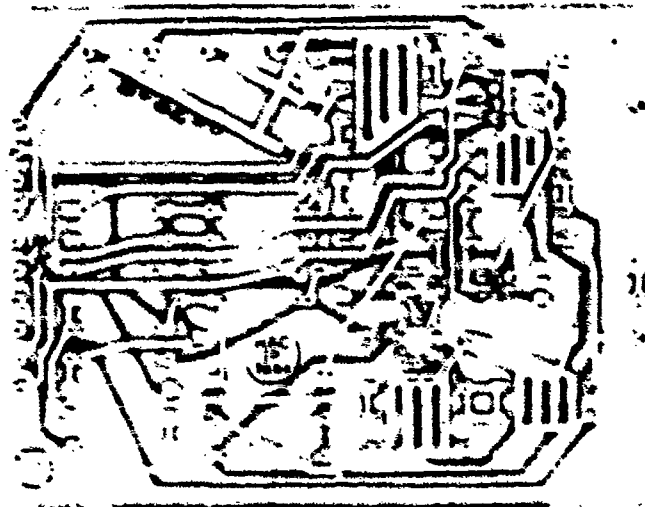

00218-18

b) BOTTOM VIEW (PHOTO 79-83785)

FIGURE 12. PRINTED WIRING BOARD

### TASK 3. INDUSTRY DEBRIEFING SESSION HELD

As required by the contract, two 1-day sessions were held on 23 and 24 June, 1980 at Hughes Aircraft Company in El Segundo. Attendees from outside Hughes were:

<u>Name</u>	<u>Organization</u>	<u>Location</u>	<u>Phone</u>
James Blust	Litton Guidance and Controls	Woodland Hills, CA	213-887-4801
Louis Boccia	Lockheed Missiles and Space	Sunnyvale, CA	408-742-3984
Jim Brewer	Interpress	Duarte, CA	213-357-5061
Robert Brown	USA MICOM	Huntsville, AL	205-876-5742
Wally Brown	De Soto	Des Plaines, IL	312-391-9203
Dick Bush	W R Grace	Columbia, MD	301-531-4566
Napoleon Celestine	Boeing Military Aircraft	Wichita, KA	316-687-2653
James Cherry	Vought	Dallas, TX	214-266-2486
Bill Clark	Magnavox Electronics	Ft. Wayne, IN	219-462-4411
Tom Clark	Ford Aerospace	Newport Beach, CA	714-759-6671
Tom Clawson	Ford Aerospace	Newport Beach, CA	714-759-5096
Irven Coppenger	Vought	Dallas, TX	214-266-7355
Jari Drlik	Lockheed Missiles and Space	Sunnyvale, CA	408-742-1336
James Ewell	Lockheed Missiles and Space	Sunnyvale, CA	408-742-9889
J. Flinchbaugh	Lilly	Los Angeles, CA	213-722-7511
James Fonda	Hughson	Erie, PA	814-868-3611
Alan Gershman	General Dynamics	Pomona, CA	714-620-6511
F. Mc Daniel	Boeing Military Aircraft	Wichita, KA	316-687-2653
Dick Moe	TRW	Redondo Beach, CA	213-536-2136

Ben Nieswiadomy	Vought	Dallas, TX	214-266-3748
Dan O'Halloran	Ford Aerospace	Newport Beach, CA	714-759-6351
George Phelps	Ford Aerospace	Newport Beach, CA	714-759-5674
Allen Puder	UVEXS	Sunnyvale, CA	408-737-2760
B. Rocha	TRW	Redondo Beach, CA	213-535-2493
Richard Schecter	Litton Guidance and Controls	Woodland Hills, CA	213-887-2160
David Selvis	Raytheon	Lowell, MA	617-230-0601
Maria Villa	E. W. Dorn	Gardena, CA	213-532-0300



SECTION 4  
CONCLUSIONS AND RECOMMENDATIONS

1. Conclusions Regarding Materials and Processes
2. Recommendation for Future MM&T Effort

## 1. CONCLUSIONS REGARDING MATERIALS AND PROCESSES

The conclusions arrived at from this evaluation were:

- 1) UV cured conformal coating of PWBs can be performed successfully.
- 2) One material, Hughson RD 3650-21, met the objectives of one-part system (no mixing), and passed all applicable MIL-I-46058 test requirements.
- 3) Minor shade changes during hydrolytic stability testing occurs within the coating, but no detrimental effect has been noted, since the lettering on components under the coating is clearly visible.
- 4) The material can be spray applied, UV cured, and oven post-cured (25 minutes at 200°F) using a Hughes SCG developed process.
- 5) Two late arriving candidates, Grace XRCP 432C and De Soto 2633-115-1 (+BP), have passed all the tests run to date (cure, hydrolytic stability, flex, insulation resistance, and appearance) and are potential candidates for later full qualification testing.

## 2. RECOMMENDATION FOR FUTURE MM&T EFFORT

It has been demonstrated that PWBs can be conformally coated with a UV sensitive material and UV cured in a matter of seconds. An additional cure (conventional) is required to ensure complete curing of the shadowed areas (areas beneath or adjacent to components that are shielded from the UV source).

### Recommendations:

- Solicit and test new material candidates to meet the requirements of MIL-I-46058. This should result in material cost reductions due to vendor competition.
- Develop combination UV/thermal one-step cure equipment. This would result in less physical handling of production hardware, which would reduce costs and reduce chances of damage due to dropping, etc.
- Develop rework and repair techniques for cured coating, including: removal and replacing of components; patching uncoated areas; fixing flaws, inclusions, bubbles; etc.
- Evaluate effect of stresses on coated glass body components. If no sleeving prior to coating is required, the assembly price would be lowered.
- Develop aerosol spray can coating application method to be used for repair, etc.
- Develop optimized methods for covering sharp projections on PWBs.
- Evaluate benign reactive diluents as replacement for the resin thinners used on this program to eliminate the need for solvent vapor exhaust systems.

## APPENDICES

- A. MIL-I-46058C Test Report - Hughes Technology Support Division
- B. Fungus Resistance Test Report - Truesdail Laboratories
- C. Thermal Humidity Aging Report No. 1 - Delsen Laboratories
- D. 120 Day Hydrolytic Stability Test Results - Specimen Photograph
- E. Thermal-Humidity Aging Report No. 2 - Delsen Laboratories
- F. Existing Conformal Coating Process - Hughes Tuscon
- G. Existing Conformal Coating Process - Hughes SCG
- H. Detailed UV Conformal Coating Process - Hughes SCG

APPENDIX A. MIL-I-46058C TEST REPORT - HUGHES  
TECHNOLOGY SUPPORT DIVISION

HUGHES

TECHNICAL INTERNAL CORRESPONDENCE

TO: J. R. Fay  
45-30

DATE: 12 November 1979  
REF: 7611.33/213

SUBJECT: Final Report - Evaluation  
of Ultraviolet (UV)  
Curable Conformal Coatings  
(Div. 45 Prime Program)

FROM: L. E. Long  
76-11-33

BLDG. 316 MAIL STA. RL29  
EXT. CC 5750 (AP)

ABSTRACT:

Qualification tests in accordance with MIL-I-46058 were performed on three different ultraviolet radiation curable conformal coatings. The three coating materials were 9332 A + B from W. R. Grace Co., 2353-7 plus benzoyl peroxide (BP) from Desoto, Inc., and RD-3650-21 from Hughson Chemical Co. The W. R. Grace and Desoto coatings are two component materials and the Hughson coating is a single component material. The W. R. Grace and Desoto materials did not meet the MIL-I-46058 requirements for fungus resistance and hydrolytic stability. The Hughson material met all requirements of MIL-I-46058 with the exception of Q (resonance). The Hughson coating, however, does not fit into the five coating types specified in MIL-I-46058. New Q (resonance) requirement values for this coating, or for U.V. cured coatings in general, should be established in order for this type coating to be qualified to MIL-I-46058.

INTRODUCTION

S&CG received a U.S. Army Contract, DAAK 40-78-C-0272, to test and evaluate ultraviolet radiation curable conformal coatings in accordance with the requirements of MIL-I-46058. S&CG personnel conducted a survey of various coating manufacturers and procured sample coatings. After an initial screening process, the three most promising candidate coatings were selected for qualification testing to MIL-I-46058. The three candidate coatings were submitted by W. R. Grace Co., Desoto, Inc., and Hughson Chemical Co.

PROCEDURE

TSD personnel prepared all test specimens, conducted the tests, except for fungus resistance and hydrolytic stability, and evaluated the results. The fungus resistance test was performed by Truesdell Laboratories, Inc., Los Angeles, and the hydrolytic stability test was performed by Nelson Testing Laboratories, Inc., Glendale. S&CG personnel applied all coatings and performed the U.V. cure procedure. Test descriptions and conditions are shown in Table I. The test specimens were marked with the following designations to identify the three different coatings: DS (Desoto), GS (W. R. Grace), and HS (Hughson). The letter "S" in each case stands for spray application. The letter designation "R", "RR", or "RRR" on test specimens refers to 1st repeat, 2nd repeat and 3rd repeat respectively. The specimens were divided as specified in Table I for Groups I to VII inclusive and subjected, in the order shown, to the inspections for their particular group.

TABLE I. Qualification Inspection.

Examination or Test	Test Method
<u>Group I</u>	
Curing time and temperature-----	FED.STD.141, Method 4061
Appearance-----	Visual-10 Power Magnification
Coating thickness-----	Micrometer
Fungus resistance-----	ASTM G-21
<u>Group II</u>	
Shelf life-----	
Appearance-----	Visual-10 Power Magnification
Insulation resistance-----	MIL-STD-202, Method 302, Cond. B
Dielectric withstanding voltage-----	MIL-STD-202, Method 301
<u>Group III</u>	
Q(resonance)-----	ASTM D150 & Para. 4.8.8
Thermal shock-----	MIL-STD-202, Method 107, Cond. B-2
Appearance-----	See I & II
Dielectric withstanding voltage-----	See II
<u>Group IV</u>	
Appearance-----	See I & II
Insulation resistance-----	See II
Moisture resistance-----	MIL-STD-202, Method 106
Appearance-----	See I & II
Insulation resistance-----	See II
Dielectric withstanding voltage-----	See II
<u>Group V</u>	
Flexibility-----	FED-STD-141, Method 6221, 1/8 Inch Mandrel
<u>Group VI</u>	
Hydrolytic stability-----	120 Days at 85 ± 1 °C and 95 ± 4% Relative Humidity
<u>Group VII</u>	
Flame resistance-----	FED-STD-406, Method 2021

## RESULTS

The results of the qualification tests listed in Table I are shown in Tables III through XVIII. A summary of all test results is shown in Table II. Table XIX lists the dry film thicknesses of all specimens which were subjected to the Group III test schedule.

TABLE II.. Summary Table of Results.

MIL-I-46058 Test	Reference Table	U.V. Cured Coating		
		Desoto	W. R. Grace	Hughson
Group I				
Curing Time and Temperature	III	Passed	Passed	Passed
Appearance	III	Passed	Passed	Passed
Coating Thickness	IV	Passed	Passed	Passed
Fungus Resistance	V	Failed	Failed	Passed
Group II				
Shelf Life	VI	Not Tested	Not Tested	Passed
Appearance	VI	Not Tested	Not Tested	Passed
Insulation Resistance	VI	Not Tested	Not Tested	Passed
Dielectric Withstanding Voltage	VI	Not Tested	Not Tested	Passed
Group III				
Q(Resonance)	VII, VIII, IX, X	<u>1/</u>	<u>1/</u>	<u>1/</u>
Thermal Shock	XI	Passed	Passed	Passed
Appearance	XI	Passed	Passed	Passed
Dielectric Withstanding Voltage	XI	Passed	Passed	Passed
Group IV				
Appearance	XII, XIII, XIV	Passed	Passed	Passed
Insulation Resistance	XII, XIII, XIV	Passed	Passed	Passed
Moisture Resistance	XII, XIII, XIV	<u>2/</u>	<u>2/</u>	Passed
Appearance	XII, XIII, XIV	Passed	Passed	Passed
Insulation Resistance	XII, XIII, XIV	<u>2/</u>	<u>2/</u>	Passed
Dielectric Withstanding Voltage	XV	Passed	Passed	Passed
Group V				
Flexibility	XVI	Passed	Passed	Passed



TABLE II (Continued).

MIL-I-46058 Test	Reference Table	U.V. Cured Coating		
		Desoto	W. R. Grace	Hughson
Group VI				
Hydrolytic Stability	XVII	Failed	Failed	Passed
Group VII				
Flame Resistance	XVIII	Passed	Passed	Passed

- 1/ The requirement values for this test are different for each generic coating type specified in MIL-I-46058. See discussion section of report.
- 2/ This test was run three times. The Desoto and W. R. Grace coatings "passed" once (2nd set) and "failed" twice (1st and 3rd sets). The requirement values are for MIL-I-46058 types AR(acrylic), SR(silicone), UR(polyurethane), and XY(parylene). The Desoto and W. R. Grace coatings "passed" and "failed" by a small margin in each case.

TABLE III. Cure and Appearance.

Specimen Designation	Curing Time and Temperature		Appearance	
	Test Result	Requirement	Test Result	Requirement
IDS 1-4	↑ U.V. Cured Plus 25 Minutes In 200 °F Air Circulating Oven 1/ ↓	Time and Temperature Recommended By The Supplier	Passed	MIL-I-46058, Para. 3.5
IGS 1-4			Passed	
IHS 1-4			Passed	

- 1/ The U.V. cure apparatus is an Interpress Corp. Scan Series T20-1. The light source is a 200 watt/inch, low intensity mercury vapor lamp. The parts or specimens are cured in the focal plane at a scan speed of 69 inches/minute.

TABLE IV. Dry Film Coating Thickness (Inches).

Desoto	IDS 1	IDS 2	IDS 3	IDS 4
	0.0015	0.002	0.001	0.001
W. R. Grace	IGS 1	IGS 2	IGS 3	IGS 4
	0.001	0.0015	0.001	0.001
Hughson	IHS 1	IHS 2	IHS 3	IHS 4
	0.001	0.0015	0.0015	0.001
Requirement	0.002 ±0.001			

TABLE V. Fungus Resistance 1/

Specimen	Rating 2/				Requirement
	After 7 Days	After 14 Days	After 21 Days	After 28 Days	
Controls (Filter Paper)	4	4	4	4	—
IDS 1-4	0	0	1	1	0
IGS 1-4	0	0	0	1	0
IHS 1-4	0	0	0	0	0

1/ See attached test report from Truesdail Laboratories, Inc.

2/ Rating: 0 = no growth, 1 = traces of growth, 2 = light growth, 3 = moderate growth, 4 = heavy growth.

TABLE VI. Shelf Life 1/.

Specimen	Appearance		Insulation Resistance		Dielectric Withstanding Voltage	
	Observation	Requirement	Test Result (Ohms)	Requirement (Ohms Minimum)	Test Result (Microamperes)	Requirement (Microamperes)
IDS 1	Passed	MIL-STD-46058 Para. 3.5	$2 \times 10^{14}$	$1.5 \times 10^{12}$	0.74	No disruptive discharge. Leakage rate shall not exceed 10 microamperes
IDS 2	Passed		$5 \times 10^{15}$		0.82	
IDS 3	Passed		$4 \times 10^{14}$		0.74	
IDS 4	Passed		$3 \times 10^{14}$		0.76	
Average 2/	—	—	$2.4 \times 10^{15}$	$2.5 \times 10^{12}$	—	—

1/ The Hughson coating was the only material tested for typical shelf life characteristics.

2/ The average of the insulation resistance of the coated specimens shall be a minimum of  $2.5 \times 10^{12}$  ohms. The insulation resistance for each coated specimen shall be not less than  $1.5 \times 10^{12}$  ohms.

TABLE VII. Q (Resonance) Values 1/

Specimen Condition	Measurement Frequency (MHz)	Q Value					
		IIIDS 1R	IIIDS 2R	IIIDS 3R	IIIDS 4R	Average	Requirement (Minimum)
DESOTO							
Uncoated Specimens	1	43.402	22.901	35.976	43.171	36.362	50
	50	73.504	73.097	71.972	71.573	72.536	70
	100	77.329	83.678	89.467	68.897	79.843	70
Coated Specimens	1	54.396	57.623	57.623	56.701	56.586	--
	50	79.197	75.171	73.126	76.782	76.069	--
	100	83.449	80.465	79.362	81.935	81.303	--
Coated Specimens (After 24 Hr. Immersion In Water)	1	42.306	35.694	38.244	38.244	38.622	--
	50	52.016	46.707	47.656	49.774	49.038	--
	100	81.273	79.676	79.454	81.133	80.384	--
W. R. GRACE							
		IIIGS 1R	IIIGS 2R	IIIGS 3R	IIIGS 4R	Average	Requirement (Minimum)
Uncoated Specimens	1	46.768	43.171	46.768	37.214	43.480	50
	50	67.688	72.930	74.653	71.972	72.810	70
	100	64.705	70.496	67.941	67.941	67.771	70
Coated Specimens	1	55.318	55.318	53.474	56.240	55.087	--
	50	80.185	74.170	79.094	75.737	77.297	--
	100	86.173	84.593	89.792	84.593	86.288	--
Coated Specimens (After 24 Hr. Immersion In Water)	1	38.244	27.008	27.008	38.244	32.626	--
	50	48.715	47.722	48.715	49.734	48.721	--
	100	82.632	80.960	88.331	79.676	82.900	--
HUGHSON							
		IIHS 1R	IIHS 2R	IIHS 3R	IIHS 4R	Average	Requirement (Minimum)
Uncoated Specimens	1	34.352	28.473	28.473	7.195	24.623	50
	50	74.653	72.697	73.097	81.561	75.502	70
	100	67.941	66.554	73.390	68.880	69.191	70
Coated Specimens	1	53.013	56.240	55.318	36.878	50.362	--
	50	80.870	80.870	79.094	102.483	85.829	--
	100	84.593	84.593	90.308	141.879	100.343	--
Coated Specimens (After 24 Hr. Immersion In Water)	1	38.244	31.690	31.690	41.665	35.822	--
	50	51.980	52.362	54.010	49.329	51.670	--
	100	83.772	80.775	80.775	139.984	96.227	--

1/ Q(Resonance) testing at 100 MHz has been eliminated from MIL-I-46058 per Amendment 5, 3 April 1979.

TABLE VIII. Q(Resonance) Values - Additional  
Hughson Specimens (3rd Set) 1/

Specimen Condition	Measurement Frequency (MHz)	Q Value					
		IIHS 1RR	IIHS 2RR	IIHS 3RR	IIHS 4RR	Average	Requirement (Minimum)
Uncoated Specimens	1	68.330	68.330	74.024	74.024	71.177	50
	50	89.824	86.805	88.808	90.144	88.895	70
	100	83.169	76.442	76.988	81.802	79.600	70
Coated Specimens	1	56.271	86.753	58.325	57.503	64.713	—
	50	70.369	67.550	68.784	71.368	69.517	—
	100	78.359	75.523	76.115	74.253	76.077	—
Coated Specimens (After 24 Hr. Immersion In Water)	1	55.423	53.575	52.651	42.375	51.006	—
	50	67.702	68.658	75.542	73.967	71.466	—
	100	68.881	68.881	70.306	67.931	68.999	—

1/ See Table VII, footnote 1.

TABLE IX. Q(Resonance) Values - Additional  
Hughson Specimens (4th Set) 1/

Specimen Condition	Measurement Frequency (MHz)	Q Value					
		IIHS 1RRR	IIHS 2RRR	IIHS 3RRR	IIHS 4RRR	Average	Requirement (Minimum)
Uncoated Specimens	1	93.685	88.863	88.363	81.974	86.346	50
	50	78.036	76.897	76.897	74.763	76.648	70
	100	80.414	81.869	79.231	78.349	79.890	70
Coated Specimens	1	79.107	80.006	76.860	78.208	78.545	—
	50	61.208	68.039	67.060	64.123	65.108	—
	100	67.563	71.536	68.386	67.985	68.867	—
Coated Specimens (After 24 Hr. Immersion In Water)	1	88.150	85.595	88.150	88.150	87.511	—
	50	68.503	72.939	69.649	72.418	70.877	—
	100	66.274	69.942	76.840	68.897	70.488	—

1/ See Table VII, footnote 1.

TABLE X. Percent Change In Q(Resonance) 1/

Specimen Condition	Measurement Frequency (MHz)	Percent Change In Q					Requirement (Maximum) 2/
		IIIDS 1-4R	IIIGS 1-4R	IIHS 1-4R	IIHS 1-4RR	IIHS 1-4RRR	
Before And After Coating	1	55.6	26.7	104.5	9.1	11.1	9
	50	4.9	7.6	13.7	21.8	15.0	19
	100	1.8	27.3	45.0	4.4	13.8	9
Before And After 24 Hr. Immersion In Water	1	31.7	40.8	28.9	21.2	11.4	9
	50	35.5	37.0	39.8	2.8	8.9	5
	100	1.1	3.9	4.0	9.3	2.4	7

1/ See Table VII, footnote 1.

2/ These requirement values are for acrylic (Type AR) coatings only (See MIL-I-46058, Para. 3.11). These values are shown for reference only and should not be binding upon acceptance or rejection of these coatings to the Q(Resonance) test. A new classification, U.V., should be established and maximum Q(Resonance) parameters designated.

TABLE XI. Thermal Shock 1/

Specimen	Appearance		Dielectric Withstanding Voltage	
	Observation	Requirement	Test Result (Microamperes)	Requirement
DESOTO				
IIIDS 1R	Passed	↑ MIL-I-46058, Para 3.5 ↓	0.48	↑ No Disruptive Discharge. Leakage Rate Shall Not Exceed 10 Microamperes ↓
IIIDS 2R	Passed		0.50	
IIIDS 3R	Passed		0.50	
IIIDS 4R	Passed		0.48	
W. R. GRACE				
IIIGS 1R	Passed		0.52	
IIIGS 2R	Passed		0.52	
IIIGS 3R	Passed		0.48	
IIIGS 4R	Passed		0.50	
HUGHSON (2nd Set)				
IIIES 1R	Passed		0.50	
IIIES 2R	Passed		0.52	
IIIES 3R	Passed		0.52	
IIIES 4R	Passed		0.50	
HUGHSON (3rd Set)				
IIIES 1RR	Passed		0.48	
IIIES 2RR	Passed	0.50		
IIIES 3RR	Passed	0.50		
IIIES 4RR	Passed	0.50		

1/ Thermal Shock Test was not run on specimens IIIES 1-RRR.

TABLE XII. Insulation and Moisture Resistance (1st Set) 1/

Specimen	Insulation Resistance (Ohms)							24 Hrs. After Test	Requirement, 2/ 3/	
	Initial Value	1st Cycle (24 Hrs.)	4th Cycle (96 Hrs.)	7th Cycle (168 Hrs.)	10th Cycle (240 Hrs.)	Initial Value	During And After Test			
DESOTO										
IVDS 3	$1.7 \times 10^{12}$	$6.5 \times 10^9$	$5.3 \times 10^9$	$4.8 \times 10^9$	$4.3 \times 10^9$		$2.0 \times 10^{12}$			
IVDS 4	$3.0 \times 10^{13}$	$1.1 \times 10^{10}$	$9.3 \times 10^9$	$6.0 \times 10^9$	$5.0 \times 10^9$		$6.5 \times 10^{12}$			$5.0 \times 10^9$
Average	$1.6 \times 10^{13}$	$8.7 \times 10^9$	$7.3 \times 10^9$	$5.4 \times 10^9$	$4.6 \times 10^9$		$4.2 \times 10^{12}$			$1.0 \times 10^{10}$
W. R. GRACE										
IVGS 3	$1.6 \times 10^{13}$	$1.3 \times 10^{10}$	$7.5 \times 10^9$	$3.7 \times 10^9$	$2.8 \times 10^9$		$4.3 \times 10^{12}$			$5.0 \times 10^9$
IVGS 4	$5.2 \times 10^{12}$	$1.1 \times 10^{10}$	$7.0 \times 10^9$	$5.0 \times 10^9$	$3.6 \times 10^9$		$5.6 \times 10^{12}$			
Average	$1.1 \times 10^{13}$	$1.2 \times 10^{10}$	$7.2 \times 10^9$	$4.3 \times 10^9$	$3.2 \times 10^9$		$4.9 \times 10^{12}$			$1.0 \times 10^{10}$
HUGHSON										
IVHS 3	$2.8 \times 10^{13}$	$3.3 \times 10^{11}$	$1.5 \times 10^{11}$	$9.0 \times 10^{10}$	$5.8 \times 10^{10}$		$4.6 \times 10^{13}$			$5.0 \times 10^9$
IVHS 4	$1.5 \times 10^{13}$	$4.4 \times 10^{10}$	$3.2 \times 10^{10}$	$2.4 \times 10^{10}$	$1.9 \times 10^{10}$		$6.4 \times 10^{12}$			
Average	$2.1 \times 10^{13}$	$1.9 \times 10^{11}$	$9.1 \times 10^{10}$	$5.7 \times 10^{10}$	$3.8 \times 10^{10}$		$2.6 \times 10^{13}$			$1.0 \times 10^{10}$

1/ Specimens IVDS 1, IVDS 2, IVGS 1, IVGS 2, IVHS 1 and IVHS 2 were erroneously separated from the 3 and 4 numbered specimens shown in the above table. These specimens were tested at a later date (see Table XIV).

2/ All test specimens satisfied the appearance requirement of MIL-I-46058, Paragraph 3.5, before and after exposure to the Moisture Resistance Test.

3/ This requirement is for MIL-I-46058 types AR(acrylic), BR(silicone), UR(polyurethane), and XY(parylene).

Special Note: See Table VI, footnote 2/ for average and individual requirements. The same explanation applies to values  $1.0 \times 10^{10}$  ohms and  $5.0 \times 10^9$  ohms.

TABLE XIII. Insulation and Moisture Resistance (2nd Set).

Specimen	Insulation Resistance (Ohms)						Requirement, 1/ 2/ (Ohms Minimum)	
	Initial Value	1st Cycle (24 Hrs.)	4th Cycle (96 Hrs.)	7th Cycle (168 Hrs.)	10th Cycle (240 Hrs.)	24 Hrs. After Test	Initial Value	During And After Test
DESOTO								
IVDS 1R	$2.0 \times 10^{14}$	$6.5 \times 10^{10}$	$5.8 \times 10^{10}$	$5.2 \times 10^{10}$	$5.0 \times 10^{10}$	$1.9 \times 10^{14}$	$1.5 \times 10^{12}$	$5.0 \times 10^9$
IVDS 2R	$1.5 \times 10^{14}$	$4.7 \times 10^{10}$	$2.4 \times 10^{10}$	$1.9 \times 10^{10}$	$1.1 \times 10^{10}$	$3.0 \times 10^{14}$		
IVDS 3R	$2.0 \times 10^{14}$	$5.8 \times 10^{10}$	$4.1 \times 10^{10}$	$4.3 \times 10^{10}$	$4.1 \times 10^{10}$	$4.0 \times 10^{14}$		
IVDS 4R	$1.8 \times 10^{14}$	$2.3 \times 10^{10}$	$1.8 \times 10^{10}$	$1.6 \times 10^{10}$	$1.0 \times 10^{10}$	$3.5 \times 10^{14}$		
Average	$1.8 \times 10^{14}$	$4.8 \times 10^{10}$	$3.5 \times 10^{10}$	$3.2 \times 10^{10}$	$2.8 \times 10^{10}$	$3.1 \times 10^{14}$	$2.5 \times 10^{12}$	$1.0 \times 10^{10}$
W. R. GRACE								
IVGS 1R	$1.2 \times 10^{14}$	$4.8 \times 10^{10}$	$3.8 \times 10^{10}$	$4.8 \times 10^{10}$	$4.0 \times 10^{10}$	$1.8 \times 10^{14}$	$1.5 \times 10^{12}$	$5.0 \times 10^9$
IVGS 2R	$1.8 \times 10^{14}$	$6.2 \times 10^{10}$	$5.6 \times 10^{10}$	$5.7 \times 10^{10}$	$5.2 \times 10^{10}$	$1.0 \times 10^{14}$		
IVGS 3R	$1.8 \times 10^{14}$	$4.8 \times 10^{10}$	$4.2 \times 10^{10}$	$4.8 \times 10^{10}$	$3.8 \times 10^{10}$	$1.0 \times 10^{14}$		
IVGS 4R	$2.0 \times 10^{14}$	$6.3 \times 10^{10}$	$5.3 \times 10^{10}$	$5.5 \times 10^{10}$	$5.2 \times 10^{10}$	$1.8 \times 10^{14}$		
Average	$1.7 \times 10^{14}$	$5.5 \times 10^{10}$	$4.7 \times 10^{10}$	$5.2 \times 10^{10}$	$4.6 \times 10^{10}$	$1.4 \times 10^{14}$	$2.5 \times 10^{12}$	$1.0 \times 10^{10}$
HUGHSON								
IVIS 1R	$2.0 \times 10^{14}$	$4.0 \times 10^{10}$	$3.6 \times 10^{10}$	$2.8 \times 10^{10}$	$2.4 \times 10^{10}$	$4.5 \times 10^{14}$	$1.5 \times 10^{12}$	$5.0 \times 10^9$
IVIS 2R	$2.0 \times 10^{14}$	$1.5 \times 10^{10}$	$1.2 \times 10^{10}$	$1.5 \times 10^{10}$	$1.4 \times 10^{10}$	$1.0 \times 10^{14}$		
IVIS 3R	$3.0 \times 10^{14}$	$1.3 \times 10^{10}$	$1.0 \times 10^{10}$	$8.0 \times 10^9$	$7.1 \times 10^9$	$3.5 \times 10^{14}$		
IVIS 4R	$8.0 \times 10^{14}$	$3.5 \times 10^{11}$	$1.4 \times 10^{11}$	$1.8 \times 10^{11}$	$1.0 \times 10^{11}$	$5.0 \times 10^{14}$		
Average	$3.8 \times 10^{14}$	$1.0 \times 10^{11}$	$5.0 \times 10^{10}$	$5.8 \times 10^{10}$	$3.6 \times 10^{10}$	$3.5 \times 10^{14}$	$2.5 \times 10^{12}$	$1.0 \times 10^{10}$

1/ See Table XII, footnote 2.

2/ See Table XII, footnote 3 and special note.



TABLE XIV. Insulation and Moisture Resistance (3rd Set) 1/

Specimen	Insulation Resistance (Ohms)								24 Hrs. After Test	Requirement, 2/ 3/	
	Initial Value	1st Cycle (24 Hrs.)	4th Cycle (96 Hrs.)	7th Cycle (168 Hrs.)	10th Cycle (240 Hrs.)	Initial Value	During And After Test				
DESOTO											
IVIS 1	3.0 x 10 <sup>15</sup>	1.5 x 10 <sup>10</sup>	8.5 x 10 <sup>9</sup>	6.5 x 10 <sup>9</sup>	5.9 x 10 <sup>9</sup>	1.2 x 10 <sup>13</sup>	1.5 x 10 <sup>12</sup>	5.0 x 10 <sup>9</sup>			
IVIS 2	4.0 x 10 <sup>15</sup>	2.0 x 10 <sup>10</sup>	1.3 x 10 <sup>10</sup>	1.0 x 10 <sup>10</sup>	7.8 x 10 <sup>9</sup>	6.0 x 10 <sup>12</sup>					
IIHIS 3	3.0 x 10 <sup>15</sup>	1.8 x 10 <sup>10</sup>	1.1 x 10 <sup>10</sup>	8.5 x 10 <sup>9</sup>	7.2 x 10 <sup>9</sup>	1.2 x 10 <sup>13</sup>					
IIHIS 4	4.0 x 10 <sup>15</sup>	2.2 x 10 <sup>10</sup>	1.4 x 10 <sup>10</sup>	1.1 x 10 <sup>10</sup>	9.5 x 10 <sup>9</sup>	1.5 x 10 <sup>13</sup>					
Average	3.5 x 10 <sup>15</sup>	1.9 x 10 <sup>10</sup>	1.2 x 10 <sup>10</sup>	9.0 x 10 <sup>9</sup>	7.6 x 10 <sup>9</sup>	1.1 x 10 <sup>13</sup>	2.5 x 10 <sup>12</sup>	1.0 x 10 <sup>10</sup>			
W. R. GRACE											
IVCS 1	4.0 x 10 <sup>15</sup>	7.0 x 10 <sup>9</sup>	7.0 x 10 <sup>9</sup>	4.4 x 10 <sup>9</sup>	3.4 x 10 <sup>9</sup>	8.0 x 10 <sup>12</sup>	1.5 x 10 <sup>12</sup>	5.0 x 10 <sup>9</sup>			
IVCS 2	3.0 x 10 <sup>15</sup>	5.0 x 10 <sup>9</sup>	2.8 x 10 <sup>9</sup>	1.3 x 10 <sup>9</sup>	8.0 x 10 <sup>8</sup>	7.8 x 10 <sup>12</sup>					
IIIGS 3	4.0 x 10 <sup>15</sup>	8.0 x 10 <sup>9</sup>	5.7 x 10 <sup>9</sup>	4.3 x 10 <sup>9</sup>	2.5 x 10 <sup>9</sup>	6.0 x 10 <sup>12</sup>					
IIIGS 4	4.0 x 10 <sup>15</sup>	1.1 x 10 <sup>9</sup>	6.5 x 10 <sup>8</sup>	5.7 x 10 <sup>8</sup>	5.0 x 10 <sup>8</sup>	3.4 x 10 <sup>11</sup>					
Average	3.8 x 10 <sup>15</sup>	5.3 x 10 <sup>9</sup>	4.0 x 10 <sup>9</sup>	2.6 x 10 <sup>9</sup>	1.8 x 10 <sup>9</sup>	6.0 x 10 <sup>12</sup>	2.5 x 10 <sup>12</sup>	1.0 x 10 <sup>10</sup>			
HUCHISON											
IVHS 1	3.0 x 10 <sup>15</sup>	5.4 x 10 <sup>10</sup>	1.8 x 10 <sup>10</sup>	1.8 x 10 <sup>10</sup>	1.6 x 10 <sup>10</sup>	2.0 x 10 <sup>13</sup>					
IVHS 2	4.0 x 10 <sup>15</sup>	4.5 x 10 <sup>10</sup>	3.5 x 10 <sup>10</sup>	3.4 x 10 <sup>10</sup>	3.3 x 10 <sup>10</sup>	2.0 x 10 <sup>13</sup>					
IIHIS 3	3.0 x 10 <sup>15</sup>	2.0 x 10 <sup>11</sup>	6.6 x 10 <sup>10</sup>	4.4 x 10 <sup>10</sup>	2.8 x 10 <sup>10</sup>	6.0 x 10 <sup>12</sup>	1.5 x 10 <sup>12</sup>	5.0 x 10 <sup>9</sup>			
IIHIS 4	3.0 x 10 <sup>15</sup>	7.2 x 10 <sup>10</sup>	5.8 x 10 <sup>10</sup>	4.3 x 10 <sup>10</sup>	2.7 x 10 <sup>10</sup>	7.5 x 10 <sup>12</sup>					
Average	3.2 x 10 <sup>15</sup>	9.3 x 10 <sup>10</sup>	4.4 x 10 <sup>10</sup>	3.5 x 10 <sup>10</sup>	2.6 x 10 <sup>10</sup>	1.3 x 10 <sup>13</sup>	2.5 x 10 <sup>12</sup>	1.0 x 10 <sup>10</sup>			

1/ Specimens IIHIS 3, IIHIS 4, IIIGS 3, IIIGS 4, IIHIS 3, IIHIS 4 were tested for Insulation and Moisture Resistance in order to make a set of four required specimens. These specimens intended for Group III testing were erroneously separated from the 1 and 2 numbered specimens and were never tested for Group III characteristic.

2/ See Table XII, footnote 2.

3/ See Table XII, footnote 3 and special note.

TABLE XV. Dielectric Withstanding Voltage <sup>1/</sup>

Leakage Current (Microamperes)					
2nd Set		3rd Set		Requirement	
Specimen	Test Result	Specimen	Test Result		
DESOTO					
IVDS 1R	1.057	IVDS 1	0.48	No Disruptive Discharge. Leakage Rate Shall Not Exceed 10 Microamperes	
IVDS 2R	0.867	IVDS 2	0.96		
IVDS 3R	0.957	IIIDS 3	1.08		
IVDS 4R	0.804	IIIDS 4	0.50		
W. R. GRACE					
IVGS 1R	1.082	IVGS 1	0.48		
IVGS 2R	0.910	IVGS 2	0.46		
IVGS 3R	0.697	IIIGS 3	1.08		
IVGS 4R	0.741	IIIGS 4	1.12		
EUGESON					
IVES 1R	1.017	IVES 1	0.52		
IVES 2R	0.839	IVES 2	0.58		
IVES 3R	1.158	IIIES 3	0.54		
IVES 4R	0.763	IIIES 4	1.06		

<sup>1/</sup> The Dielectric Withstanding Voltage was not run on 1st set of specimens due to inadequate number of specimens available.

TABLE XVI. Flexibility Test.

Specimen	Observation	Requirement	
DESOTO			
VDS 1	Passed	No Cracking or Cracking	
VDS 2	Passed		
VDS 3	Passed		
VDS 4	Passed		
W. R. GRACE			
VGS 1	Passed		
VGS 2	Passed		
VGS 3	Passed		
VGS 4	Passed		
HUGHSON			
VES 1	Passed		
VES 2	Passed		
VES 3 <u>1/</u>	Failed, 1 3/16 Inch Crack		
VES 4	Passed		
VES 4R	Passed		

1/ This test specimen had a coating thickness of 0.005 inches (5 mils) at the edge of the specimen where the failure occurred. The coating thickness for types AR(acrylic), ER(epoxy), and UR(polyurethane) shall be 0.002 ±0.001 inches. For type XY(parylene), the coating thickness shall be 0.0006 ±0.0001 inches. For type SR(silicone), the coating thickness shall be 0.005 ±0.003 inches.

TABLE XVII. Hydrolytic Stability 1/

Specimen	Appearance/Observation				Requirement
DESOTO	After 28 Days	After 56 Days	After 84 Days	After 120 Days	
VIDS 1 VIDS 2 VIDS 3	↑ Slight Discoloration ↓	↓ Slight Corrosion, Tackiness, and Loss of Adhesion ↓	↓ Slightly Worse Corrosion, Tackiness, and Loss of Adhe- sion ↓	Coating Frac- tures, Cor- rosion, MIL-R-55182 Resistor Mark- ings Illegi- ble 3/	MIL-I-46058, Para. 3.15
VIDS 4	Control	Control	Control	Control	
W. R. GRACE					
VIGS 1 VIGS 2 VIGS 3	↑ Slight Discoloration ↓	↑ Extreme Corrosion, Tackiness, and Liquefaction of Coating ↓	↓ Severe Corrosion, Tackiness, and Liquefaction of Coating ↓	Complete Rever- sion, Corrosion, MIL-R-55182 Resistor Mark- ings Illegible 3/	
VIGS 4	Control	Control	Control	Control 2/	
HUGHSON					
VHS 1 VHS 2 VHS 3	↑ Slight Darkening ↓	↑ Additional Darkening ↓	↓ No Additional Degradation ↓	Slight Darkening - All Resistor Markings Legible 3/	
VHS 4	Control	Control	Control	Control	

1/ See attached test report from Delsen Testing Laboratories, Inc.

2/ This control specimen was slightly tacky to the touch after 120 days at 25 °C and 50 percent relative humidity.

3/ There are two resistors on each test specimen. The MIL-R-39008 resistor is color coded and the MIL-R-55182 resistor is numerically coded.



TABLE XIX. Dry Film Thickness (Inches).

Specimen	Uncoated Specimen Thickness	Total Thickness (Both Sides Coated)	Total Coating Thickness	Approximate Coating Thickness Per Side <u>1/</u>
<b>DESOTO</b>				
IIIDS 1R	0.059	0.060	0.001	0.0005
IIIDS 2R	0.061	0.0625	0.0015	0.0007
IIIDS 3R	0.063	0.064	0.001	0.0005
IIIDS 4R	0.060	0.061	0.001	0.0005
<b>W. R. GRACE</b>				
IIIGS 1R	0.058	0.059	0.001	0.0005
IIIGS 2R	0.060	0.062	0.002	0.001
IIIGS 3R	0.059	0.060	0.001	0.0005
IIIGS 4R	0.062	0.063	0.001	0.0005
<b>HUGHSON</b>				
IIHS 1R	0.059	0.060	0.001	0.0005
IIHS 2R	0.062	0.063	0.001	0.0005
IIHS 3R	0.060	0.0615	0.0015	0.0007
IIHS 4R	0.062	0.063	0.001	0.0005
IIHS 1RR	0.058	0.060	0.002	0.001
IIHS 2RR	0.059	0.0615	0.0025	0.0012
IIHS 3RR	0.059	0.061	0.002	0.001
IIHS 4RR	0.061	0.063	0.002	0.001
IIHS 1RRR	0.061	0.0645	0.0035	0.0017
IIHS 2RRR	0.061	0.064	0.003	0.0015
IIHS 3RRR	0.062	0.0645	0.0025	0.0012
IIHS 4RRR	0.062	0.0645	0.0025	0.0012

1/ The dry film thickness of the coating on each side of the specimen was not measured separately. The total coating thickness of both sides was measured and divided by two. Thus, the coating thickness per side is only an approximation.

DISCUSSION

The Desoto and W. R. Grace U.V. cured coatings failed the Fungus Resistance, and Hydrolytic Stability Tests. These two coatings, therefore, are not acceptable for inclusion into MIL-I-46058. The Hughson coating met all requirements of MIL-I-46058 with the exception of Q(Resonance).

The U.V. cured coatings do not fit into any of the five coating types specified in MIL-I-46058. The "percent change in Q" values for these coating types vary considerably from one to another. New Q(Resonance) requirement values for the U.V. curable generic type of coating should be established for qualification purposes. The Hughson and Desoto coatings are based on a urethane-acrylate resin system and the W. R. Grace coating is based on a polyene-polythiol resin system. The Q(Resonance) values for the Desoto, W. R. Grace, and Hughson uncoated specimens in Table VII did not meet the minimum Q requirement at 1 MHz for the MIL-P-13949, Type GF laminate material which was used to make the test specimens. The "percent change in Q" values (see Table VIII), before and after coating, for the IIHS 1-4R, IIIS 1-4R, and IIHS 1-4R specimens are, therefore, not significant at 1 MHz.

The Desoto and W. R. Grace coatings were not retested for Q(Resonance) nor tested for shelf life characteristics because they failed the hydrolytic stability test. Two additional sets of Hughson Group III specimens, IIHS 1-4RR and IIHS 1-4RRR, were prepared and subjected to the Q(Resonance) test. The "Percent change in Q" values for the IIHS 1-4RR set of specimens at 1 MHz, before and after coating, and before and after immersion in water should be corrected because of an inconsistent Q value for one of the four specimens in that group. The Q value for coated specimen IIHS 2RR at 1 MHz is much higher than the Q value for the other three specimens at 1 MHz (see Table VIII). This Q value, 86.753, should be deleted and the other three Q values averaged. The corrected average Q value will then be 57.366 instead of 64.713. The corrected "percent change in Q" value for the IIHS 1-4RR set of specimens at 1 MHz before and after coating will be 19.4 percent instead of 9.1 percent. The corrected "percent change in Q" value for the IIHS 1-4RRR set of specimens at 1 MHz before and after immersion in water will be 11.1 percent instead of 21.2 percent. These corrections reflect more accurate values for this set of Hughson specimens. It is not uncommon to get large variations in Q values due to contamination or moisture effects. It is recommended that at least two sets of four specimens each be used for future Q(Resonance) testing to compensate for specimens with "inordinate" Q values relevant to most of the other Q values within the group. Q(Resonance) testing at 100 MHz has been eliminated from MIL-I-46058 per Amendment 5, 3 April 1979, and should no longer be included for any future work.

It has been stated that the Hughson U.V. coating passed the hydrolytic stability test even though the coating darkened (turned amber) after the 120 day test (see photo). MIL-I-46058, paragraph 3.15.2, states that "conditioning shall not cause coating discoloration greater than any discoloration of the control panel". The Project Manager, J. R. Fay, showed the exposed hydrolytic stability test specimens to the cognizant U.S. Army personnel. The U.S. Army position was that the exposed Hughson coating exhibited a "shade change" and not a color change. This shade change or darkening of the coating was considered acceptable to U.S. Army reviewing personnel.

FUTURE WORK

The U.S. Army requires at least two approved sources of U.V. cured conformal coatings qualified to MIL-I-46058. Future work will include the evaluation of an additional U.V. cured conformal coating submitted by W. R. Grace. The Hughson coating may also be retested for hydrolytic stability. The foregoing activities are predicated on a time/cost extension of the existing program contract.

*L. E. Long*

L. E. Long

Approved:

*R. A. Dunaetz*

R. A. Dunaetz, Head  
Adhesives & Finishes Section

LEL:dlh



APPENDIX B. FUNGUS RESISTANCE TEST REPORT - TRUESDAIL  
LABORATORIES

# TRUESDAIL LABORATORIES, INC.



CHEMISTS • MICROBIOLOGISTS • ENGINEERS  
RESEARCH • DEVELOPMENT • TESTING

4101 N. FIGUEROA STREET  
LOS ANGELES 9006  
AREA CODE 213 • 223-1546  
CABLE: TRUELAB

**CLIENT** Hughes Aircraft Company  
Centinela and Teale  
Culver City, California 90230  
ATTN: Mr. George Acosta Bldg 17, M/SJL32,  
Lynn Lora, Bldg 316, M/S R 129

**SAMPLE** Three sets of coated glass (four specimens each)  
Contract No. DAAK40-79-C-0272  
P. O. No. S4-403253-FEM

**DATE** July 16, 1979

**RECEIVED** May 30, 1979

**LABORATORY NO.** 26840

**INVESTIGATION** Fungus Resistance Testing (ASTM G-21-70).

## RESULTS

Fifteen day cultures of the following pure culture fungi were harvested, washed and their spore counts adjusted to 1,000,000 ( $\pm$  200,000) per ml.

<u>Organism</u>	<u>ATCC Number</u>
Aspergillus niger	9642
Penicillium funiculosum	9644
Chaetomium globosum	6205
Trichoderma sp	9645
Pullularia pullulans	9348

The spore suspensions were combined and sprayed onto the samples and controls which were placed on sterile nutrient salts agar. The samples were incubated at 30°C for 28 days and examined weekly. The results are given below:

<u>Sample Designation</u>	<u>Observations (Rating)</u>			
	<u>7 days</u>	<u>14 days</u>	<u>21 days</u>	<u>28 days</u>
1. Hughson Glass Panels, HBS 1-4	0	0	0	0
2. DeSoto Glass Panels, IDS 1-4	0	0	1	1
3. Grace Glass Panels, IGS 1-4	0	0	0	1
4. Controls (filter paper)	4	4	4	4

B-1

This report represents only the results of the investigation and is not intended to be a statement of the quality of the product or process. It is the responsibility of the customer to ensure that the product or process is suitable for the intended use. The results of this investigation are based on the information provided by the customer and are not intended to be used as a basis for any other action.

\*Rating: 0 = no growth, 1 = traces of growth, 2 = light growth,  
3 = moderate growth, 4 = heavy growth

The samples are being returned by separate cover.

Respectfully submitted,

TRUESDAIL LABORATORIES, INC.

*Karl W. Schiller*

Karl W. Schiller, M. S.  
Chief Microbiologist



APPENDIX C. THERMAL HUMIDITY AGING REPORT  
NO. 1 - DELSEN LABORATORIES

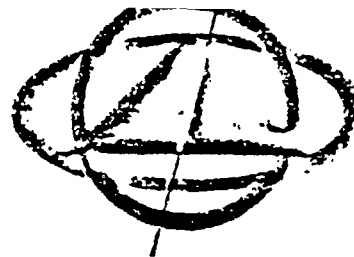

**TEST REPORT**

IN ACCOUNT WITH  <b>HUGHES AIRCRAFT</b> Cantinela and Teale Culver City, CA 90230	Date	10/15/79	Page 1 of 4 Pages
	W.O. No.	T 16459	P.O. No. S4-403254FEM
	Identification	As noted	Shower 27273

**THERMAL-HUMIDITY AGING**

**DESCRIPTION :** Twelve (12) specimens, identified below, were submitted for Thermal-humidity aging per Mil-I-46058C, Amendment 4, paragraphs 3.15 and 4.8.12.

<u>GROUP</u>	<u>SERIAL NUMBERS</u>
I	VI GS1, VI GS2, VI GS3, and VI GS4
II	VI DS1, VI DS2, VI DS3, and VI DS4
III	VI HS1, VI HS2, VI HS3, and VI HS4

Specimen 4 of each group was maintained at 25°C and 50 percent relative humidity as a control.

**TEST METHOD :** Mil-I-46058C, Amendment 4, paragraphs 3.15 and 4.8.12; Fed-Std-141a, Method 4061.1.

**REQUIREMENTS:** 3.15 Thermal-humidity aging. When tested as specified in 4.8.12, the coating materials shall meet the following requirements:

3.15.1 Hydrolytic stability. There shall be no evidence of reversion as indicated by softening, chalking, blistering, cracking, tackiness, loss of adhesion, or liquefaction.

3.15.2 Discoloration. The examination shall determine legibility and distinguishability of identification markings and color codes used to identify parts. Conditioning shall not cause coating discoloration greater than any discoloration of the control panel.

As a direct reaction to clients, the public and other consumers, this report is submitted for the exclusive use of the client to whom it is addressed. This report applies only to the work(s) tested and is not necessarily indicative of the quality of apparatus, materials or operating products. Use of this report, whether in whole or in part, or of any parts or segments hereof, in any advertising or publicity or for without prior written authorization from Delsen Corporation is prohibited.

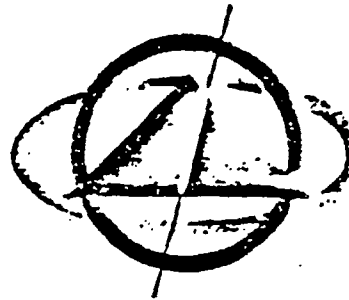

W.O. No.	T 16459	Page 2 of 4 Pages
----------	---------	-------------------

**PROCEDURE:** 4.8.12 Thermal-humidity aging (see 3.15). One panel shall be maintained as a control at 25°C and 50 percent relative humidity. Three panels shall be subjected to 120 days at 85° + 1°C and 95 + 4 percent relative humidity, and examined as follows (using normal or corrected 20/20 vision):

- (a) After 28, 56 and 84 days of exposure, the panels shall be returned to 25°C and 50 percent relative humidity and held for 2 hours. The panels shall be examined following each exposure and then returned to the chamber for continuation of conditioning.
- (b) After the 120-day aging period, the panels shall be returned to 25°C and 50 percent relative humidity and held for 7 days. The panels shall be examined and compared with the control panel. The panels shall also be tested for tackiness in accordance with method 4061 (Dry-through for varnish, lacquers and enamels) of Fed-Std-141.

**RESULTS :**

EXPOSURE PERIOD  
(Days)

RESULTS

28

All nine specimens met the requirements of paragraphs 3.15, 3.15.1, and 3.15.2, except all were slightly darker than the control specimens.

56

(1) Specimens GS1, GS2, and GS3 showed extreme corrosion, tackiness, and liquefaction. The resistor color codes and identifications were readable.

(2) Specimens DS1, DS2, and DS3, showed slight corrosion, tackiness, and loss of adhesion. The resistor color codes and identifications were readable.

As a mutual protection to clients, the public and Delsen Corporation, the report is submitted for the exclusive use of the client to whom it is addressed. The report covers only the samples tested and is not necessarily indicative of the quality of components similar or identical products. Use of the report, whether in whole or in part or of any such or similar connected therewith, in any advertising or publicity matter, without prior written authorization from Delsen Corporation is prohibited.

C-4



W.O. No.	T 16459	Page	3	of	4	Pages
----------	---------	------	---	----	---	-------

**RESULTS (continued)**

EXPOSURE PERIOD  
(Days)

RESULTS

56

(3) Specimens HS1, HS2, and HS3, met all the requirements of paragraphs 3.15, 3.15.1, and 3.15.2, except for additional darkening of the coating.

All nine specimens exhibited measling of the base material.

84

(1) Degredation (including corrosion) of specimens DS1, DS2, and DS3 was slightly worse than that noted after 56 days.

(2) Specimens GS1, GS2, and GS3 were severely corroded and showed severe liquefaction and tackiness.

(3) Specimens HS1, HS2, and HS3, showed no additional degradation since the 56 day level; except for additional blistering of the base material.

120

All nine specimens showed additional degradation from that noted after 84 days.

120 days plus  
7 days at 25°C  
and 50% R.H.

(1) Specimens HS1, HS2, and HS3 met all the requirements of paragraphs 3.15, 3.15.1, and 3.15.2, except for the slight darkening of the coating, after the tackiness test of Fed-Std-141a, Method 4061.1.

As a mutual protection to clients, the public and Delsen Corporation, this report is submitted for the exclusive use of the client to whom it is addressed. This report applies only to the samples tested and is not necessarily indicative of the condition of equipment similar or identical thereto. Use of this report, whether in whole or in part, or of any data or figures contained hereon, in any advertising or publicity matter, without prior written consent, express from Delsen Corporation is prohibited.

C-5

TESTING • RESEARCH AND DEVELOPMENT



W.O. No.

T 16459

Page

4

of

4

Pages

**RESULTS (continued)**

**EXPOSURE PERIOD**

(Days)

**RESULTS**

120 days plus  
7 days at 25°C  
and 50% R.H.

(2) Specimens DS1, DS2, and DS3 met the requirements of the tackiness test. Fractures, not associated with the tackiness test, were also noted on all three specimens. The markings of the Mil-R-55182 resistor were totally illegible. Also, the control sample, DS4, was slightly tacky to the touch.

(3) Examination of specimens GS1, GS2, and GS3 at 40X magnification showed the coating had reverted and dripped from the surface; only a thin, discontinuous, tacky film remained.

Photographs of one specimen from each group were submitted to Ed Anderson, Hughes Aircraft Co., after 68, 84, and 120 days exposure.

All twelve (12) specimens were returned to client for further evaluation.

Respectfully submitted,

**DELSEN TESTING LABORATORIES, INC.**

As a matter of protection to clients, the public and Delsen Corporation, this report is submitted for the exclusive use of the client to whom it is addressed. The report applies only to the samples tested and is not necessarily indicative of the quality of equipment, material or finished products. Use of this report, in whole or in part, or of any data or diagrams contained therein, in any advertising or publicity matter, without prior written authorization from Delsen Corporation is prohibited.



APPENDIX D. 120 DAY HYDROLYTIC STABILITY  
TEST RESULTS - SPECIMEN PHOTOGRAPH

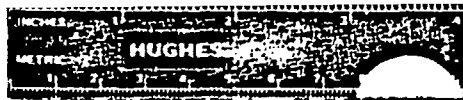

CONTROL

EXPOSED SPECIMENS

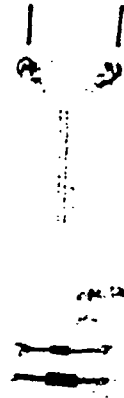

HUGHSON CHEMICALS RD-3650-21

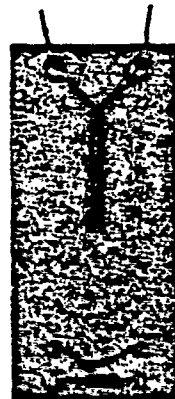
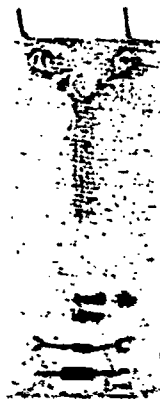

DESOTO, INC. 2353-7 PLUS BP

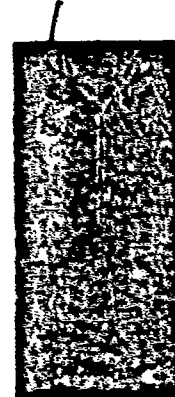
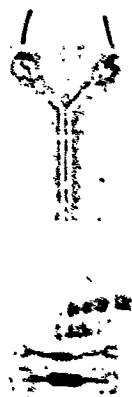

W. R. GRACE CO. 9332 A+B

120 DAY HYDROLYTIC STABILITY TEST RESULTS

APPENDIX E. THERMAL-HUMIDITY AGING REPORT  
NO. 2 - DELSEN LABORATORIES



**TEST REPORT**

IN ACCOUNT WITH <b>HUGHES AIRCRAFT</b> Centinela and Teale Culver City, CA 90230	Date	6/9/80	Page	1	of	7	Pages
	N.O. No.	T 17157	P.O. No.	28-716201LEN			
	Identification	As noted	Shooter	None			

**THERMAL-HUMIDITY AGING**

**DESCRIPTION:** Twenty-five (25) specimens, identified below, were submitted for Thermal-humidity aging per MIL-I-46058C, Amendment 4, paragraph 3.15 and 4.8.12.

<u>GROUP</u>	<u>SERIAL NUMBER</u>
I	MS-1, MS-2, MS-3, MS-4, MS-5
II	GST-1, GST-2, GST-3, GST-4, GST-5
III	HSR-1, HSR-2, HSR-3, HSR-4, HSR-5
IV	DR-1, DR-2, DR-3, DR-4, DR-5
V	HP16-170-1, HP15-170-2, HP16-170-3, HP16-170-4, HP16-170-5

Specimen 4 of each group was maintained at 25°C and 50 percent relative humidity as a control.

Specimen 5 of each group was an uncoated control exposed to the Thermal-Humidity Aging along with specimens 1, 2 and 3.

Three specimens of each coated type plus one each uncoated specimen (the control for that particular coating group) were placed in an individual dessicator using a different dessicator for each of the five different coated material specimens. A total of five dessicators were used. Except for the Teflon specimen holder, no other materials were in the dessicators.

As a matter of protection to clients, the public and Delsin Corporation, this report is submitted for the exclusive use of the client to whom it is addressed. This report applies only to the material tested and is not necessarily indicative of the qualities of apparently similar or identical products. Use of this report, whether in whole or in part, or of any facts or figures contained therein, in any advertising or publicity matter, without prior written authorization from Delsin Corporation is prohibited.

RESEARCH AND DEVELOPMENT

TESTING

E-3



WO No

T 17157

Page 2

of 7

Pages

TEST METHOD : MIL-I-46058C, Amendment 4, Paragraphs 3.15 and 4.8.12;  
FED-STD-141A, Method 4061.1.

REQUIREMENTS: 3.15 Thermal-humidity aging. When tested as specified in 4.8.12, the coating materials shall meet the following requirements:

3.15.1 Hydrolytic stability. There shall be no evidence of reversion as indicated by softening, chalking, blistering, cracking, tackiness, loss of adhesion, or liquefaction.

3.15.2 Discoloration. The examination shall determine legibility and distinguishability of identification markings and color codes used to identify parts. Conditioning shall not cause coating discoloration greater than any discoloration of the control panel.

PROCEDURE : 4.8.12 Thermal-humidity aging (see 3.15). One panel shall be maintained as a control at 25°C and 50 percent relative humidity. Three panels shall be subjected to 120 days at 85° + 1°C and 95 + 4 percent relative humidity, and examined as follows (using normal or corrected 20/20 vision):

- (a) After 28, 56 and 84 days of exposure, the panels shall be returned to 25°C and 50 percent relative humidity and held for 2 hours. The panels shall be examined following each exposure and then returned to the chamber for continuation of conditioning.
- (b) After the 120-day aging period, the panels shall be returned to 25°C and 50 percent relative humidity and held for 7 days. The panels shall be examined and compared with the control panel. The panels shall also be tested for tackiness in accordance with Method 4061 (Dry-through for varnish, lacquers and enamels) of FED-STD-141.

As a mutual protection to clients, the public and Delsen Testing Laboratories, Inc., this report is submitted for the exclusive use of the client to whom it is addressed. This report applies only to the samples tested and is not necessarily indicative of the quality of apparently similar or identical products. Use of this report, whether in whole or in part, or of any text or insights connected therewith, in any advertising or publicity matter, without prior written authorization from Delsen Testing Laboratories, Inc. is prohibited.

E-6

TESTING • RESEARCH AND DEVELOPMENT



WO No T 17157	Page 3 of 7 pages
------------------	-------------------

RESULTS:

A. Visual examination after 28 days exposure

Group I:

MS-1, MS-2, MS-3: Light yellow-brown streaks were noted along the length of the specimens on both sides. These streaks appear to be where the coating is thicker. Otherwise, the specimens have discolored only slightly. All other requirements were met.

Group II:

GST-1, GST-2, GST-3: Only slightly discolored. Meets all requirements.

Group III:

HSR-1, HSR-2, HSR-3: Only slightly discolored. Meets all requirements.

Group IV:

DR-1, DR-2, DR-3: Slightly darker (brown) than HSR and GST specimens.

Group V:

HP16-170-1, HP16-170-2, HP16-170-3: Moderate brown with slight orange tint. Meets all other requirements.

NOTE:

All five bare laminates showed a very slight darkening in color (darker green).

As a mutual protection to clients, the public and Delsen Testing Laboratories, Inc., this report is submitted for the exclusive use of the client to whom it is addressed. This report applies only to the samples tested and is not necessarily indicative of the quality of associated similar or identical products. Use of this report, whether in whole or in part, or of any tests or methods connected therewith, in any advertising or publicity matter without prior written authorization from Delsen Testing Laboratories, Inc., is prohibited.

E-5

TESTING • RESEARCH AND DEVELOPMENT



W.O. No.	T 17157	Page 4	of 7	Pages
----------	---------	--------	------	-------

3. Visual Examination after 56 days exposure.

Group I:

MS-1, MS-2, MS-3: All three coated specimens showed additional darkening of the yellow-brown streaks previously noted at the 28 day exposure level. MS-1 and MS-3 showed a slight loss of legibility of the MIL-R-55182 resistors. The MIL-R-55182 resistor of MS-2 was completely faded away. There does not appear to be any change in the coating in the area of the resistors which would be attributed to an interaction between the marking ink and the coating (when examined at normal (corrected) vision). There was no loss of legibility of the MIL-R-39008 resistors. All other requirements were met, except for a slight amount of corrosion along all conductors

Group II:

GST-1, GST-2, GST-3: Only slightly discolored. The markings of all three MIL-R-55182 resistors were completely faded away. Meets all other requirements, except for a slight amount of corrosion along the conductors of GST-3.

Group III:

HSR-1, HSR-2, HSR-3: Only slightly discolored. The markings of all three MIL-R-55182 resistors were completely faded away. Meets all other requirements, except for a slight amount of corrosion along the conductors of HSR-3

Group IV:

DR-1, DR-2, DR-3: All three samples continue to be slightly darker than the HSR and GST specimens. All markings of the MIL-R-55182 resistors are completely faded away. Meets all other requirements.

Group V:

HP16-170-1, HP16-170-2, HP-16-170-3: All markings on all resistors are completely legible. The coatings are somewhat darker. The "Y" pattern seems to be darkened, also. Meets all other requirements.

NOTE: All five bare laminates showed a very slight darkening in color. (shift almost imperceptible).

As a mutual protection to clients, the public and Delsen Testing Laboratories, Inc., this report is submitted for the exclusive use of the client to whom it is addressed. This report applies only to the samples tested and is not necessarily indicative of the quality of apparently similar or identical products. Use of this report, whether in whole or in part, or of any tests or weights connected therewith, in any advertising or publicity matter, without prior written authorization from Delsen Testing Laboratories, Inc. is prohibited.



WO No

T 17157

Page 5

of 7

Pages

C. Visual Examination after 89 days exposure.

Group I:

MS-1, MS-2, MS-3: All three coated specimens showed additional darkening. The markings on the MIL-R-55182 resistors on MS-1 and MS-1 were only slightly legible and completely gone on MS-2. The markings of the MIL-R-39 resistors were totally legible, except for the gold band. MS-2 showed considerable corrosion on one lead and terminal of the MIL-R-55182 resistor. There was additional corrosion of the "Y" pattern conductors. All other requirements were met.

Group II:

GST-1, GST-2, GST-3: All three coated specimens showed a slight amount of corrosion along the "Y" conductors. The gold band was partially gone on all three specimens. Otherwise, there was no apparent change or difference from the 56 day level.

Group III:

HSR-1, HSR-2, HSR-3: Slight corrosion of the MIL-R-39008 resistor leads was noted on HSR-1 and HSR-2. A moderate amount of corrosion was noted on the MIL-R-39008 resistor leads on HSR-3. The gold band was partially gone on all three specimens. Otherwise, there was no apparent change from the 56 day level.

Group IV:

DR-1, DR-2, DR-3: Slight corrosion of the MIL-R-39008 resistor leads was noted on all three specimens. Also, all three specimens were slightly darker in color. Only the orange and yellow bands were legible on the three specimens.

Group V:

HP16-170-1, HP16-170-2, HP-16-170-3: Slight corrosion of the MIL-R-39008 resistor leads was noted on all three specimens. All three specimens were significantly darker, making all markings essentially unreadable.

NOTE: All five bare laminates showed only slight additional darkening.

As a matter of protection to clients, the public and Delsen Testing Laboratories, Inc., this report is submitted for the exclusive use of the client to whom it is addressed. This report applies only to the samples tested and is not necessarily indicative of the quality of apparently similar or identical products. Use of this report, whether in whole or in part, or of any tests or methods connected therewith, in any advertising or publicity matter without prior written authorization from Delsen Testing Laboratories, Inc. is prohibited.

E-7

TESTING • RESEARCH AND DEVELOPMENT





WO No.

T 17157

Page 6

of 7

Pages

D. Visual examination after 120 days exposure.

Group I:

MS-1, MS-2, MS-3: All three coated specimens showed evidence of liquefaction as exhibited by flow patterns (A non-uniform sag of the coating caused by gravity) across the specimens. All MIL-R-39008 markings were totally illegible; all MIL-R-39008 markings apparently were not degraded further. Additional corrosion of all conductors ("Y" pattern and resistor leads) was noted. The coatings were slightly tacky to the touch.

Group II:

GST-1, GST-2, GST-3: No apparent change from the 89 day level.

Group III:

HSR-1, HSR-2, HSR-3: The MIL-R-39008 resistor lead of HSR-3 show additional corrosion. There was no other apparent change from the 89 day level.

Group IV:

DR-1, DR-2, DR-3: The MIL-R-39008 resistor leads on all three specimens showed additional corrosion. There was no other significant change from the 89 day level.

Group V:

HP16-170-1, HP16-170-2, HP16-170-3: Additional corrosion of all resistor leads was noted. There was no evidence of corrosion on the "Y" pattern. All three specimens were notably darker than the 89 day level colors. There were apparently no other changes.

NOTE: All five bare laminates showed little or no additional darkening.

As a matter of protection to clients, the public and Delsen Corporation, this report is submitted for the exclusive use of the client to whom it is addressed. This report contains data to the company, tested and is not necessarily indicative of the quality of apparently similar or identical products. Use of this report, whether in whole or in part, or of any text or figures contained therein, in any advertising or publicity matter, without prior written authorization from Delsen Corporation is prohibited.

E-8

TESTING • RESEARCH AND DEVELOPMENT



W O No T 17157	Page 7 of 7 Page
-------------------	------------------

E. Tackiness test after 120 days Thermal-Humidity aging plus 7 days at 23°C and 50% relative humidity.

METHOD:

MIL-STD-141, Method 4061

RESULTS:

Following the tackiness test, there was no additional degradation of any of the materials (specimens) when compared to the 120 day results. All five coatings were hard to the touch with no evidence of chalking, blistering, tackiness, loss of adhesion, or liquefaction.

Respectfully submitted,

DELSEN TESTING LABORATORIES, INC.

As a mutual protection to clients, the public and Delsen Corporation, this report is submitted for the exclusive use of the client to whom it is addressed. The report applies only to the samples tested and is not necessarily indicative of the quality of apparently similar or identical products. Use of this report, whether in whole or in part, or of any words or designs connected therewith, in any advertising or publicity matter without prior written authorization from Delsen Corporation is prohibited.

E-9

TESTING • RESEARCH AND DEVELOPMENT

APPENDIX F. EXISTING CONFORMAL COATING  
PROCESS - HUGHES TUCSON

HUGHES STANDARD

1. SCOPE

1.1 Scope. This Specification covers the requirements for the application of polyurethane coatings to electronic assemblies operating in the temperature range of -65 to 212 °F (-54 to 100 °C) (219 to 373 K) (see 6.1).

1.2 Classification

1.2.1 Types. The process shall be one of the following types as specified according to the type of material used:

Type I	Using HMS 16-1533, Type I, one-component, nonelastomeric compound. Solvent resistant, atmospheric moisture cured.
Type II	Using HMS 16-1533, Type II, two-component, nonelastomeric compound. Solvent resistant.
Type III	Using HMS 16-1533, Type III (MIL-I-46058, Type UR), two-component, nonelastomeric compound. Solvent resistant.
Type IV	Using MIL-I-46058, Type UR, two-component, elastomeric compound. Not solvent resistant.
Type V	Using MIL-I-46058, Type UR, one-component, nonelastomeric compound, solvent resistant. Curing is moisture independent.

1.2.2 Grades. Type III and Type V coatings shall be one of the following grades as specified according to the environmental protection required:

Grade A	Some protection against condensing moisture.
Grade B	Handling protection, with minimal environmental protection.

1.3 Superseding data. When existing drawings call out Type III and do not specify grade, Type III, Grade A, shall be used.

F-3

COATING, CONFORMAL, POLYURETHANE TYPE, REVERSION  
RESISTANT, FOR ELECTRONIC ASSEMBLIES, APPLICATION OF

PAGE  
1  
of  
14

HP 16-119

REVISION

R

2. APPLICABLE DOCUMENTS

2.1 Government documents. The following documents of the latest issue in effect form a part of this Specification to the extent specified herein:

SPECIFICATIONS

Federal

O-A-51	Acetone, Technical
TT-I-735	Isopropyl Alcohol
TT-M-261	Methyl Ethyl Ketone, Technical
TT-N-95	Naphtha, Aliphatic
TT-X-916	Xylene (For Use in Organic Coatings)

Military

MIL-E-7125	Ethylene Glycol Monoethyl Ether Acetate
MIL-I-46058	Insulating Compound, Electrical (For Coating Printed Circuit Assemblies)
MIL-C-81302	Cleaning Compound, Solvent, Trichlorotrifluoroethane

STANDARDS

Military

MIL-STD-105	Sampling Procedures and Tables for Inspection by Attributes
-------------	---

2.2 Other publications. The following documents of the latest issue in effect form a part of this Specification to the extent specified herein:

Hughes Aircraft Company

HMS 16-1533	Coating Compound, Polyurethane Conformal, Electrically Insulating, Reversion Resistant
HMS-20-1707	Tracer Material, Fluorescent, Conformal Coating
HMS 16-1963	Epoxy Adhesive, Temperature Curing, Flexible
HP 9-24	Solder Flux Removal, Rosin Base

PAGE		REVISION
2	HP 16-119	R

3. REQUIREMENTS

3.1 End product requirements

3.1.1 Workmanship

3.1.1.1 Applicable to all coated areas. Coating shall not exhibit gross film defects, such as frothy areas (massive bubbles), blisters, or peeling. Normal pull back from sharp edges and points shall be permitted.

3.1.1.2 Applicable to coatings over underlying circuitry. The coating shall exhibit no pinholes, cracks, broken (unfilled) bubbles, craters, or voids which expose underlying circuitry. There shall be no bubbles (broken or unbroken) larger than approximately 0.03 inch (0.76 millimeter (mm)) in diameter bridging more than 50 percent of the distance between circuitry. The coating shall be free of foreign particles.

3.1.2 Cured coating thickness. The cured coating thickness shall be as follows.

3.1.2.1 Type I, Type II, Type III Grade A, and Type IV and Type V Grade A. The cured coating thickness shall be 0.003 to 0.006 inch (0.076 to 0.15 mm).

3.1.2.2 Type III Grade B and Type V Grade B. The cured coating thickness shall be 0.001 to 0.003 inch (0.025 to 0.076 mm).

3.1.3 Surface condition. Types I, II, III, and V coatings shall be dry to touch and shall exhibit no softness or tackiness. Type IV coating shall be dry and resilient with a rubbery feel.

3.2 Facilities and equipment (Not Applicable)

3.3 Material. The materials used for coating in accordance with this Specification shall be as specified in Table I.

PAGE	REVISED
3	HF 16-119 R

TABLE I. MATERIALS

Material	Source
Primer (JR228-1)	HMS 16-1963, Class 1 or 2
Methyl ethyl ketone (MEK)	TT-M-261
Coating:	
Type I	HMS 16-1533, Type I
Type II	HMS 16-1533, Type II
Type III	HMS 16-1533, Type III and MIL-I-46058, Type UR (Conathane CE 1155)
Type IV	MIL-I-46058, Type UR (Uralane 5750)
Thinner	
Butyl cellosolve acetate. (polyurethane grade)	Union Carbide Corp. New York, New York
or	
Cellosolve acetate (polyurethane grade)	MIL-E-7125
Type V	MIL-I-46058, Type UR (Humiseal Type 1A33)
Thinner	
Xylene	TT-X-916, Grade A (Humiseal thinner #33)
Ultraviolet tracer	HMS 20-1707

3.4 Procedure

3.4.1 Surface preparation. The surfaces shall be cleaned of foreign matter in a manner that will make them receptive to conformal coating in accordance with this Specification. Areas intended to be free of coating shall be masked by any convenient method that will leave no residual products.

3.4.1.1 Circuit boards. Circuit boards shall be cleaned in accordance with HP 9-24, Grade B, except that the requirements for insulation resistance shall be deleted. Boards shall be sufficiently dry (cleaning solvents and moisture evaporated) to prevent coating imperfections during application and cure. An oven dry cycle may be employed, but the drying schedule shall not exceed the cure schedule.

3.4.1.2 Other assemblies. Assemblies other than circuit boards shall be cleaned with one of the following solvents: a combination of 50 ±1 parts of isopropyl alcohol conforming to TT-I-735 (grade optional) and 50 ±1 parts of naphtha conforming to TT-N-95, Type I, fluorocarbon conforming to MIL-C-81302 (type and class optional) "PC", "TE" or "TF" (manufactured by E. I. du Pont de Nemours Co, Wilmington, Delaware) or vapor degreased in Freon "PC", "TE" or "TF". If these solvents are not compatible with the assemblies of the surfaces to be coated, only isopropyl alcohol shall be used. After solvent cleaning, the assemblies may be dried in a forced air oven, but part temperature shall not exceed 160 °F (71 °C) (344 K).

3.4.1.3 Handling cleaned surfaces. The cleaned boards or assemblies shall be handled and stored prior to further processing in a manner that will prevent contamination or absorption of excess moisture.

3.4.2 Primer preparation. Application of primer shall be optional as approved by the cognizant Process Engineering activity. Primer specified in Table I shall be mixed as specified in Table II.

TABLE II. MIXING RATIOS FOR PRIMER

HMS 1963 Class	Material	Concentration, Parts by Weight
1	JR 228-1 Resin	10
	JR 228-1 Hardener	12
	Methyl ethyl ketone	20 to 60
2	JR 228-1 Frozen premix	10
	Methyl ethyl ketone	5 to 8

3.4.2.1 Primer cure. The primer shall be air dried for not less than 30 minutes at room temperature before conformal coating is applied.



3.4.3 Coating material preparation. Coating materials specified in Table I shall be mixed as specified in Table III.

TABLE III. MIXING RATIOS FOR COATINGS

HP 16-119 Type	Material	Concentration
I	HMS 16-1533, Type I (PC 18 Std or PC 18 M (fluorescent))  Thinner Ultraviolet tracer dye <u>1</u> /	100 parts by weight (pbw)  As required 12 drops or 0.6 cc per 100 grams of coating
II (See Table I)	HMS 16-1533, Type II (PC 15 Std)  Thinner	2 parts of Component A to 1 part of Component B by weight  As required
III	MIL-I-46058, Type UR (Conathane CE 1155)  Thinner	100 parts of Component A to 70 parts of Component B by weight  As required
IV	MIL-I-46058, Type UR (Uralane 5750)  Thinner	100 parts of Component B 18 parts of Component A by weight  As required
V	MIL-I-46058, Type UR (Humiseal type 1A33)  Thinner	100 parts by weight  As required

1/ When Hysol PC 18 Std is used, the ultraviolet tracer dye shall be added. However, no tracer dye addition is necessary for PC 18 M (fluorescent).

3.4.4 Coating application. The coating shall be applied to achieve the coating thickness range specified in 3.1.2. To achieve the thickness range specified, it may be necessary to apply the coating in more than one application (see 6.2). The primer specified in 3.4.2 may be used as an initial coating application over difficult-to-wet areas. When so used, the primer shall be applied sparingly, so as to avoid excessive fillets.

3.4.4.1 Drying time (Types I, II, III, IV). All coatings shall be air dried for not less than 10 minutes at room temperature before being placed in an oven, whether the coating application is between coats or as a final coat. Between applications, the coating shall be dried for a period conforming to Figure 1, Curve A, but not to exceed Curve B. Type V coating material shall be dried for a period conforming to Figure 2, Curve A, but not to exceed Curve B.

At elevated temperatures, the coating shall be dried in a ventilated circulating air oven or ventilated infrared oven. Infrared heating, when used, shall provide for uniform heating of the various coated surfaces and shall be controlled to produce the required surface temperature.

PAGE	REV	REVISION
7	RP 16-119	R

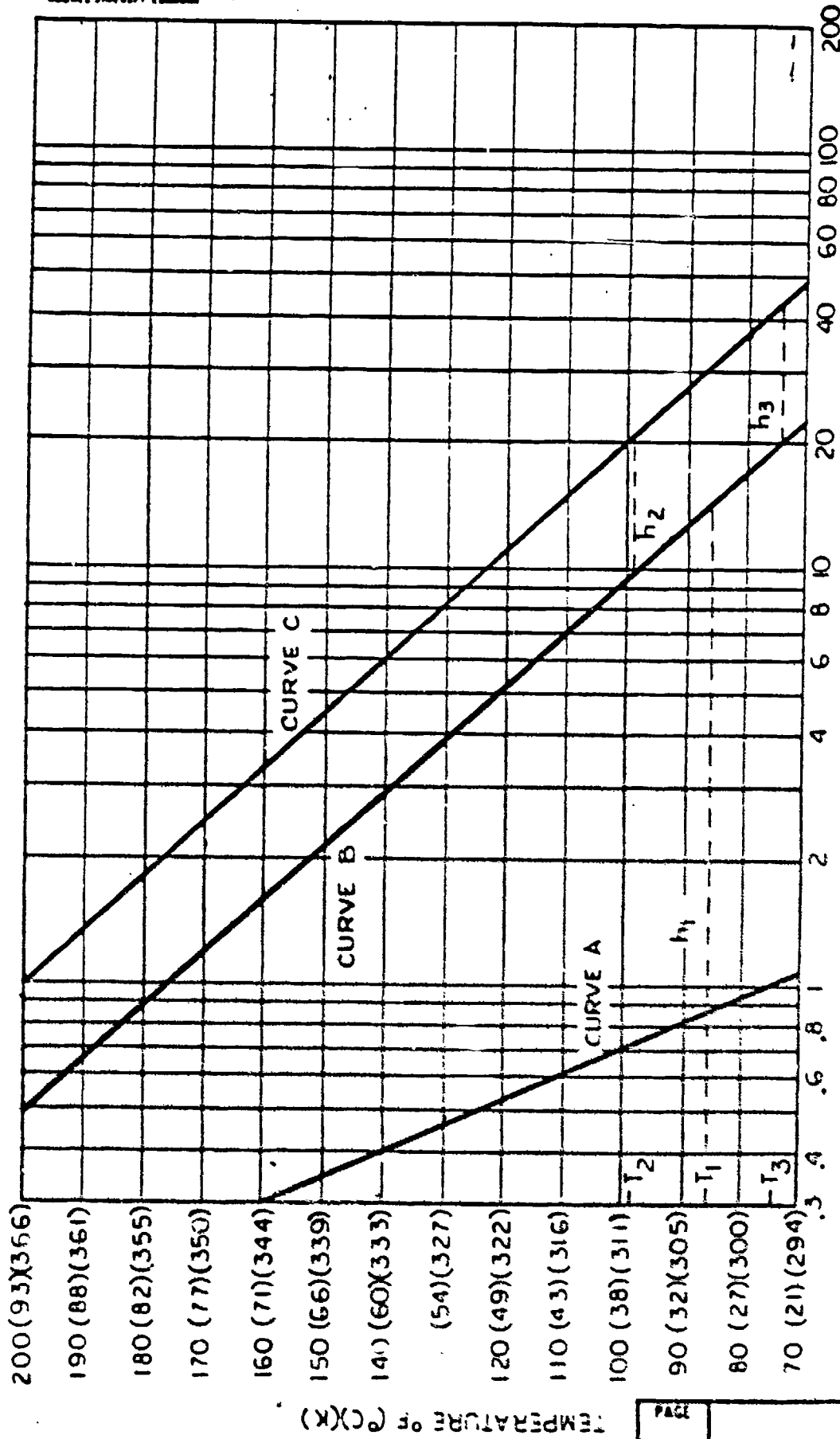

TIME IN HOURS, MINIMUM

1. The temperature shall be accurate within  $\pm 10$  of  $(\pm 6 \text{ oc})$  ( $\pm 6 \text{ K}$ ) and shall not exceed the range shown. Elevated temperature cure may be accomplished in an air circulating or infrared oven.
2. When a different temperature is used to complete the cure than that used to achieve handling strength, the minimum time to cure can be determined by subtracting the time to handling strength at the new temperature from the time at this temperature. Full cure may be completed at different temperatures; for example,  $t_1$   $t_2$  hours at temperatures  $T_1$  and  $T_2$ ; or  $t_1$   $t_3$  hours at temperatures  $T_1$  and  $T_3$ , respectively.

FIGURE 1. CURE SCHEDULE (TYPES I, II, III AND IV COATINGS)

TEMPERATURE OF °C(K)

F-10

8	16:00	21
---	-------	----

HUGHES STANDARD

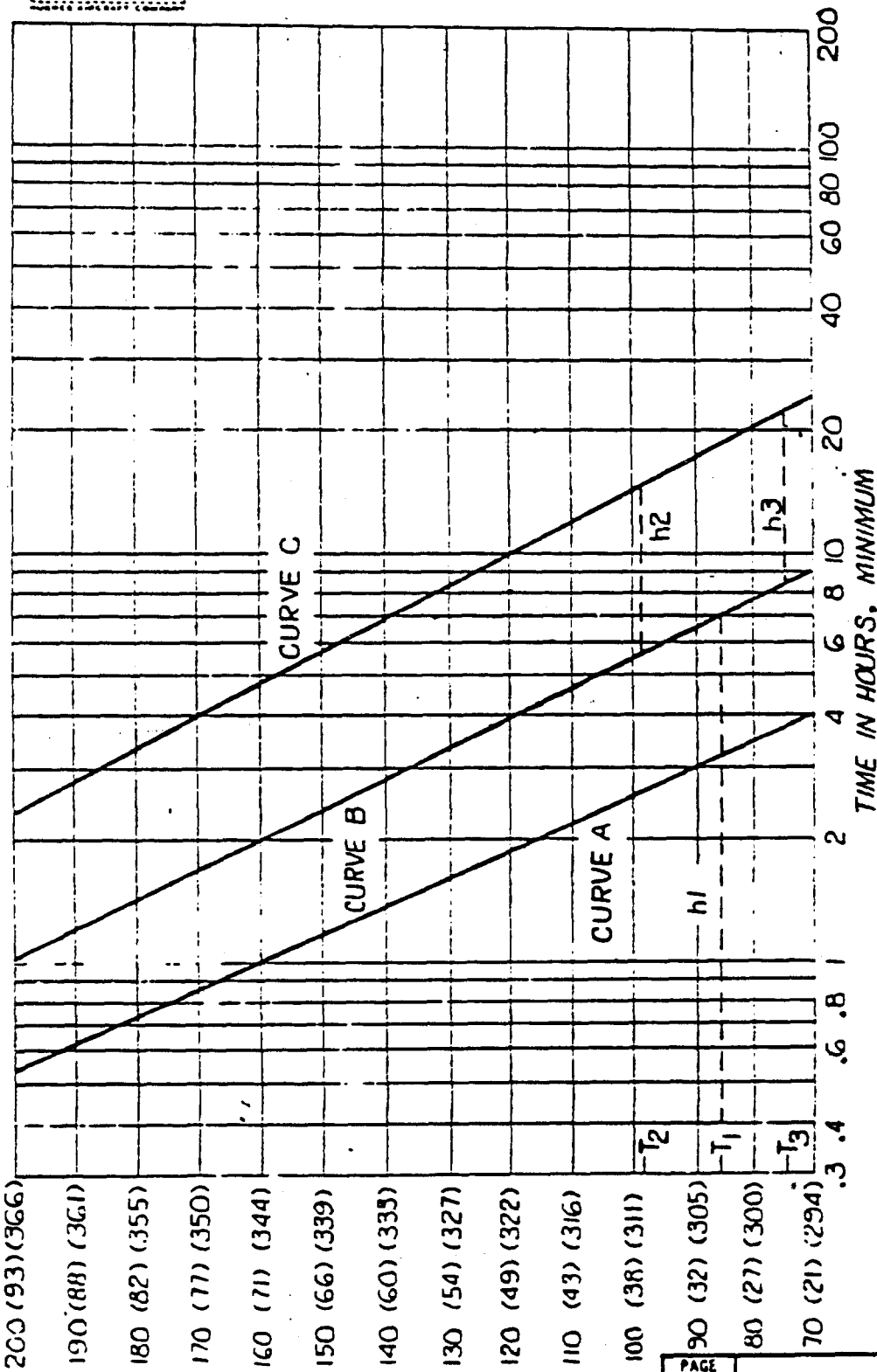

1. The temperature shall be accurate within  $\pm 10^\circ\text{F}$  ( $\pm 6^\circ\text{C}$ ) ( $\pm 6^\circ\text{K}$ ) and shall not exceed the range shown. Elevated temperature cure may be accomplished in an air circulating or infrared oven.
2. When a different temperature is used to complete the cure than that used to achieve handling strength, the minimum time to cure can be determined by subtracting the time to handling strength at the new temperature from the time at this temperature. Full cure may be completed at different temperatures; for example,  $t_1$   $t_2$  hours at temperatures  $T_1$  and  $T_2$ ; or  $t_1$   $t_2$  hours at temperatures  $T_1$  and  $T_3$ , respectively.

FIGURE 2. CURE SCHEDULE (TYPE V COATING)

9	611-61-111	REVISION
PAGE		R

3.4.5 Curing

3.4.5.1 Types I, II, III and IV. Curing shall be accomplished in accordance with Figure 1, Curve C.

3.4.5.2 Type V. Curing shall be accomplished in accordance with Figure 2, Curve C.

NOTE: Cure may be interrupted at any point after Curve B (minimum cure time for handling), and final cure may be completed at room temperature concurrent with inspection or continued processing. For Type I, the room temperature curing time shall be doubled if the relative humidity is less than 50 percent. For Type I, an open container of water (plain tap water is satisfactory) shall be maintained inside the oven during elevated temperature curing.

3.4.6 Touch-up. Small uncoated areas or structurally impaired coating shall be touched up or "spotted" by brush application of the material. Drying and curing shall be as specified in 3.4.4.1 and 3.4.5.

3.4.7 Cleanup. Excess material shall be removed in a manner that will not damage or detrimentally affect the coating, circuit board or assembly. Uncured excess material shall be wiped off with a solvent such as methyl ethyl ketone (MEK) conforming to TT-M-261, acetone conforming to O-A-51, or butyl cellosolve acetate (see 3.3). Cured material filling terminal board holes, in which soldered connections are to be made, shall be removed by touching the eyelets with a hot soldering iron tip, caution being taken to avoid overheating and lifting of the film adjacent to the heated area. Coatings that have aged longer than 4 days will be more difficult to remove. All four types of coating can be removed using a hot knife. Cured Type IV coating is readily softened by solvents (see 6.1).

3.4.8 Storage. Thinned Type I material remaining after the spraying operation may be stored in tightly sealed jars or cans for periods from 1 to 2 weeks preferably at 40 to 50 °F (4 to 10 °C) (277 to 283 K). All other activated materials (coating Types II, III, IV and primer) shall be discarded after 4 hours from the time of mix, except sealed bottled material (for touch-up purposes) which shall be discarded at the end of 8 hours. Type V material shall be discarded when its viscosity exceeds 250,000 centipoises, or after 6 months from time of first usage.

PAGE	REVISION
10	2
HF 16-119	

# HUGHES STANDARD

## 4. QUALITY ASSURANCE PROVISIONS

4.1 Quality conformance inspection. Quality conformance inspection comprises all of the tests performed on individual lots which have been submitted for acceptance. The tests are described in the following subparagraphs.

4.1.1 Sampling for quality conformance. All parts shall be inspected 100 percent. The cognizant Quality activity may, in lieu of 100 percent inspection, select a sampling plan in accordance with MTL-STD-105. Where applicable, sampling of lots processed on a line flow basis to achieve the required sampling level may be accomplished by selecting at random the required number of parts or specimens during the lot processing as the lot accumulates at the end of the line.

4.1.2 Lot formation. A lot shall consist of all parts of similar configuration coated at one time by the same process, by the same processing activity using the same batch of coating material in accordance with this Specification and submitted at one time. The determination of similarity shall be the responsibility of the cognizant Process Engineering activity. Parts processed on a line flow basis using automated equipment shall be considered processed at one time provided the coating material used is from the same batch and the coating operation does not extend beyond one shift and the operation is not interrupted for equipment maintenance or significant adjustments.

4.1.3 Inspection. Inspection of the sample specified in 4.1.1 to determine compliance with the characteristics specified in Table IV shall be in accordance with the corresponding test and inspection paragraphs.

TABLE IV. QUALITY CONFORMANCE INSPECTION

Characteristic	Requirement Paragraph	Test and Inspection Paragraph
Workmanship	3.1.1	4.2.2.1
Coating thickness	3.1.2	4.2.2.2
Surface conditions	3.1.3	4.2.2.3
Packaging and packing	5.1	4.2.2.4

F-13

PAGE	REVISION
11	R

CODE IDENT NO. 42577

**4.2 Test methods and procedures**

**4.2.1 Test specimen preparation.** Coating thickness shall be determined on specimens that are representative of the work being inspected and shall be prepared and coated concurrently with the representative units. For "flow line operations", one specimen shall be prepared at the beginning, one at the middle, and one at the end of the run. For "batch type operations", no less than one specimen shall be prepared for each batch.

**4.2.2 Tests**

**4.2.2.1 Visual inspection.** The coating shall be visually inspected, without magnification, for conformance to the workmanship requirements in 3.1.1 and for conformance to the packaging and packing requirements in 5.1.

**4.2.2.2 Coating thickness.** Coating thickness shall be measured using a micrometer caliper or equivalent measuring device to establish conformance to the requirements of 3.1.2. The coated part or test specimen shall be measured directly in flat areas at least 0.25 inch (6.35 mm) from component bodies, conductor paths and board edges.

**4.2.2.3 Surface condition.** The coating shall be subjected to the scratching or abrading action of heavy fingernail pressure or similar pressure applied by an untreated orangestick to establish conformance to the applicable requirement of 3.1.3.

**5. PREPARATION FOR DELIVERY**

**5.1 Packaging and packing.** The coated and finished assemblies shall be placed in polyethylene bags or other suitable containers as approved by the cognizant Process Engineering activity to prevent damage or contamination, if the finished assemblies are stored or shipped prior to usage.

PAGE	REV	REVISION
12	16-119	1

**6. NOTES**

**6.1 Intended use.** The procedures described herein are intended to provide a physical and environmental protective barrier against abrasion and contamination of electronic assemblies. This process will not always provide a continuous coating for covering sharp points, corners and edges. The coating may form a fillet with component bodies at circuit board interfaces, depending on the proximity of the component body to board surface.

**NOTE:** These coatings should not be used on printed wiring boards where moisture can condense or for the protection of high impedance circuits in a moist atmosphere.

Type I coating requires extended periods of time for curing where the humidity of the environmental air is below 50 percent. Types II, III, IV and V coatings may be cured where the humidity is below that level.

Type IV coating is preferred where modules may undergo prolonged thermal cycling or where minimum stress to the component body or soldered joint is of paramount importance. However, Type IV coating should not be used where resistance to strong solvents is required.

**NOTE:** Solvents, such as, 1, 1, 1-trichloroethane, trichloroethylene, toluene, and methyl ethyl ketone will soften and swell the Type IV coating after a few minutes at room temperature. Hot Freon TF or Freon TE, naphtha, and alcohols have little effect and such effect is normally reversible upon drying.

**6.2 Coating uniformity.** Coating uniformity within the specified thickness range (see 3.1.2) can often be improved by the application of thin multiple coats rather than a thicker single coat.

**6.3 Filletting (For reference only).** When using Types I, II, III or V coatings, it is recommended that filletting between glass-bodied axial lead components (i.e., diodes, capacitors) and the printed wiring board or adjacent components be limited to that resulting from nominal thickness coating and minimal runoff from the component. Filletting in excess of this amount may be removed by use of a solvent-moistened brush to reduce the amount of filletting.

PAGE	NO	REVISION
11	NP 16-119	1



RELEASE AND REVISION RECORD

Rev	Authority	Description	Release	
			Date	Approval
—	—	Initial release as HP 16-119.	3/8/65	
A thru K	—	Records of changes are contained in the document history file.		
L	CMER 51154	P1: Revise Para. 1.2, and add 1.2.1, 1.2.2, and 1.3 to add Grades A and B. P3: Revise Para. 3.1.2, add 3.1.2.1 and 3.1.2.2. P6: Deleted Para. 3.4.4.1, Figure 1, renumber 3.4.4.2. P10: Add Para. 6.3.	5-31-77	<i>G. Sypher</i> G. Sypher
M	CMER 51160	P8 and P9: Section 4 completely revised for clarification and to address the differences between batch processing and time flow processing.	9-12-77	<i>Y. Moriwaki</i> Y. Moriwaki
N	CMER 18092	P1: Moved Type listing from 1.3 to 1.2.1. P3: Revised para 3.1.1.2. P8: Revised para 4.1.1.2, added 4.1.1.3. P9: Revised para 4.2.1. Minor editorial changes throughout.	12-14-77	<i>Y. Moriwaki</i> Y. Moriwaki
P	CMER 21418	P1: Revised scope by correcting temperature range and deleting last sentence. P2: Added MIL-STD-105 to document section P10: Added note to 6.1	10-03-78	<i>G. Russell</i> G. Russell
R	CMER 22538	Specification has been revised to add Type V coating process and primer cure (3.4.2.1), to revise 1.2.2 (Grades) and 4.2.1 (Sampling plan).	3/1/79	<i>D. P. Andersen</i> D. P. Andersen
F-16			PAGE 14	REVISION 16-119

APPENDIX G. EXISTING CONFORMAL COATING  
PROCESS - HUGHES SCG

# HUGHES STANDARD

## RESTRICTED USAGE - APPROVED PROGRAMS

THE PROCESS DESCRIBED HEREIN SHALL BE USED ONLY FOR THE PROGRAMS LISTED BELOW. PROCESSING TO THIS DOCUMENT FOR ANY OTHER USAGE IS PROHIBITED EXCEPT WITH THE PRIOR APPROVAL OF THE COMPONENTS AND MATERIALS LABORATORIES.

APPROVED PROGRAMS: SPACE AND COMMUNICATIONS PROGRAMS

### 1. SCOPE

1.1 This specification covers a process for the application of an elastomeric, polyurethane, conformal coating system to electronic assemblies. This process is approved for space applications at temperatures from  $-65$  to  $200^{\circ}\text{F}$  ( $-54$  to  $93^{\circ}\text{C}$ ) ( $219$  to  $300^{\circ}\text{F}$ ).

### 1.2 Classification

1.2.1 Types. The process shall be one of the following types specified in accordance with the use of coating system.

Type I	Two step conformal coating system providing good coverage
Type II	One step conformal coating system providing adequate coverage

1.3 Superseding data. When no type is specified on an existing drawing, Type I shall be used.

### 2. APPLICABLE DOCUMENTS

2.1 Government documents. The following documents of the latest issue in effect form a part of this specification to the extent specified herein:

#### SPECIFICATIONS

##### Federal

TT-T-543	Toluene, Technical
TT-X-915	Xylene (For Use in Organic Coatings)

##### Military

MIL-E-7125	Ethylene Glycol Monocethyl Ether Acetate
MIL-I-17178	Insulating Compound, Electrical For Coating Printed Circuit Assemblies.
MIL-S-47119	Silicone Dioxide, Microfine

COATING, CONFORMAL, ELASTOMERIC, POLYURETHANE TYPE,  
FOR ELECTRONIC ASSEMBLIES, APPLICATION OF

PAGE

1

OF

1

REVISION

3

2.2 Other publications. The following documents of the latest issue in effect form a part of this specification to the extent specified herein:

Hughes Aircraft Company

HMS 16-2105	Coating Formulations for Electronic Assembly
HMS 20-1802	Talc, Powdered
HMS 20-1966	Accelerators for Resin Systems
HP 9-47	Cleaning of Electronic Assemblies

3. REQUIREMENTS

3.1 End product requirements

3.1.1 Workmanship

3.1.1.1 Appearance. The cured coating shall have the following appearance:

- a. The etched circuitry and components of the electronic assembly shall be visible after coating.
- b. A fillet shall be required around each component.
- c. The coating shall have no blisters, cracking, or peeling. No pinhole, foreign particle, or bubble (broken or unbroken), or combination of these, shall bridge between different circuits. No pinhole or broken bubble shall expose conductors. There shall be no bubbles (broken or unbroken), larger than 0.045 inch (1.11 millimeters (mm)) in diameter bridging more than 50 percent of the distance between circuitry. Bubbles bridging more than 50 percent of the distance between circuitry are permitted if they are filled.
- d. The coating that is in contact with conductors shall be free of foreign particles.
- e. Bubbles shall be permitted in the fillet area adjacent to components provided that they occupy not more than 30 percent of the fillet perimeter.

3.1.1.2 Continuity. Assemblies shall be completely coated except as noted in 3.1.1.1 and with the following exceptions:

- a. Areas under flat-bottomed components which are mounted flush with the wiring board need not be coated.
- b. Areas surrounding a mounting stud may remain uncoated providing there is at least 0.010 inch (0.25- mm) of acceptable coating insulating any circuitry from the uncoated areas.

3.1.1.3 Completeness of cleanup. Masking material and adhesive residue shall be completely removed. All glass material shall be trimmed to the required contour.

PAGE		REVISION
2	HP 16-175	D

# HUGHES STANDARD

3.1.2 Coating thickness. The total coating thickness shall be 0.007  $\pm$  0.001 inch (0.178  $\pm$  0.025 mm) per side when measured on the flat areas of the board.

## 3.2 Facilities and equipment

3.2.1 Processing areas. Silicone mold release agent or silicone grease shall not be allowed in the immediate processing area where coatings are applied (see 6.2).

3.3 Materials. The materials used in accordance with this Specification shall be as specified in Table 1.

TABLE 1. MATERIALS

Materials	Material Description	Source
Polyurethane resin and curing agent	Uralane 5750 B/A	MIL-I-46058, Type UR
Accelerator	Dibutyltin dilaurate	HMS 20-1966, Type I
Fillers	Talc	HMS 20-1802
	Colloidal silica	MIL-S-47129
Thinners	Cellosolve acetate (ethylene glycol monoethyl ether acetate), urethane grade	MIL-E-7125
	Toluene	TT-T-546
Frozen premix	Complete formulation (see Table II)	HMS 16-2109 1
Two-component kit	Complete formulation (see Table II)	HMS 16-2109 2

1/ HMS 16-2109 types and formulations correspond to those contained herein.

3.4 Procedure

3.4.1 Handling. All cleaned boards shall be handled only with clean noncontaminated gloves or handling aids.

3.4.2 Assembly preparation. Prior to coating, surfaces shall be cleaned in accordance with HP 9-47. Dry for not less than 2 hours at 150 to 210 °F (66 to 99 °C) (339 to 372 K).

3.4.3 Masking. Components, contact areas, jacks, switches, etc, specified on the applicable drawing as requiring no protective coating, shall be suitably masked with tape or masking covers. The masking material shall be in close contact with the surface in order to prevent the coating from seeping under the masking material during application.

3.4.4 Coating with Type I material. Type I conformal coating system shall consist of not less than one spray coat (Formulation I) followed by not less than one dip or pour coat (Formulation II).

PAGE		REVISION
1	HP 16-170	D

**HUGHES STANDARD**

3.4.5 Coating formulations. The polyurethane coatings shall be formulated in accordance with Table II:

TABLE II. COATING FORMULATIONS

Material	Coatings (Parts by Weight) <sup>4/</sup> <sup>5/</sup>			
	Type I			Type II
	Formulation I Spray	Formulation II Dip or Pour	Formulation III Touchup	
Uralane B	100 ±1.0	100 ±1.0	100 ±1.0	100 ±1.0
Uralane A	18 ±0.2	18 ±0.2	18 ±0.2	18 ±0.2
Accelerator, 1 per- cent solution <sup>1/</sup>	0.7 ±0.1	0.7 ±0.1	0.7 ±0.1	0.7 ±0.1
Talc filler <sup>2/</sup>	47 ±1.0	—	—	—
Colloidal silica filler <sup>2/</sup>	—	—	0 to 8	1 to 2
Solvent blend of 90 percent toluene and 50 percent cellosolve acetate, by volume	45 ±1.0 <sup>3/</sup>	0 to 28	—	0 to 20

- <sup>1/</sup> Prepare 1 percent solution by adding 4 drops of accelerator to each 10 grams of toluene conforming to TT-T-548 or xylene conforming to TT-X-916, Grade A.
- <sup>2/</sup> Dry filler in air circulating oven for not less than 1 hour at 150 °F (66 °C) (339 K) to 200 °F (93 °C) (366 K) prior to mixing.
- <sup>3/</sup> Initial value (see 3.4.6.1, Formulation I (3)).
- <sup>4/</sup> All components may be premixed, except Uralane A, and stored at room temperature for up to six months. Mixture must be degassed prior to storing.
- <sup>5/</sup> All these coating types and formulations are available as frozen premixes (-40 °F (-40 °C) (233 K) or as two-component kits (see SMS 16-2105).

## HUGHES STANDARD

3.4.6 Mixing. The materials specified in 3.4.5 shall be thoroughly mixed until the mixture is smooth and free of lumps. Type I, Formulation I coating shall be mixed using a high speed mechanical stirrer (such as Lightning Mixer Model F, from Mixing Equipment Company, Rochester, New York). The other formulations may be machine-mixed or hand-mixed.

### 3.4.6.1 Detailed mixing instructions

#### a. Type I, Formulation I

- (1) Weigh out all components except the accelerator and blend to a homogeneous mixture.
- (2) Add the accelerator to the mixture and thoroughly blend in.
- (3) Add additional solvent blend if needed to facilitate spray application. (Typical spray viscosity is 175 centipoises (0.175 pascal-seconds)).

#### b. Type I, Formulations II and III, and Type II

- (1) Weigh out all components, except the accelerator, and blend to a homogeneous mixture.
- (2) Add the accelerator to the mixture and thoroughly blend in.
- (3) Mixture shall be degassed to eliminate entrapped air. Degassing shall not be prolonged; it shall be sufficient only to cause first foaming to collapse.

3.4.7 Work life. The mixed polyurethane coatings shall be applied within 1 hour after mixing.

3.4.8 Spray application. The Type I, Formulation I coating shall be sprayed on each side of the assembly as described below and shall cover all visible unmasked external surfaces. Additional solvent (toluene-cellosolve acetate blend) may be added when using frozen premix to obtain a sprayable mixture. (Typical spray viscosity is 175 centipoises (0.175 pascal-seconds)).

- a. Spray the coating onto the assembly using clean, dry air at a pressure sufficient to provide good atomization.
- b. Spray one pass across the entire surface of the assembly.
- c. Rotate the assembly 90 degrees and repeat b.
- d. Rotate the assembly 90 degrees more and repeat b.
- e. Rotate the assembly 90 degrees more and repeat b., so that one pass has been applied from four directions.
- f. Repeat procedures a. through e. as necessary to cover incompletely coated areas. Pay particular attention to surfaces such as leads, lead tips, and other conductor areas.
- g. Cure the coated assembly in accordance with 3.4.10.

NOTE: Where a surface is inaccessible for adequate spray application, brush application of Type I, Formulation I may be applied.

PAGE	REVISION
6	D



## HUGHES STANDARD

3.4.9 Dip or pour application. Unless otherwise specified on the engineering drawing, the entire assembly shall be dip coated or pour coated as follows:

Dip the entire assembly into a container filled with Type I, Formulation II, or Type II coatings and remove the assembly at an extraction rate of  $2.0 \pm 0.5$  inches ( $51 \pm 12$  mm) per minute or pour the coatings onto the surface area to be coated, or pour and brush where drainage cannot be performed well. If necessary, spread the coatings over the surface by using a soft bristle brush to obtain complete coverage and generous fillets. Allow the coated assembly to drain for at least 3 minutes or until the coating stops running. Reposition the assembly several times during the drain cycle to maintain uniform coating buildup and generous fillets.

NOTE: Additional solvent (toluene-cellosolve acetate blend) may be added when using the frozen premix to obtain a dippable or pourable mixture. (Typical pour viscosity is 505 centipoises (0.525 pascal-seconds)).

3.4.10 Curing. A drying cycle is recommended prior to curing which will help reduce the amount of bubbles which can occur in the cured coating. The following drying methods may be used:

Method I

Place the assembly in a vacuum oven at 150 to 180 °F (66 to 82 °C) (339 to 355 K) and 5 inches of mercury absolute (6.3 kilopascals) or lower pressure for 4 to 6 minutes.

Method II

Air dry the coated assembly for not less than 6 hours.

The coated assemblies shall be cured in accordance with Figure 1, using a ventilated heat source. Coated assemblies may proceed to next processing stage, as required, after minimum cure. However, full cure is required prior to any environmental testing.

3.4.11 Touchup. Examine the cured coating visually and under ultraviolet light to determine coverage. Touch up as required over leads, terminals, and part-to-part areas using a soft bristle brush and Type I, Formulations II and III or Type II coating.

3.4.11.1 Touchup procedure. The touchup procedure shall be as follows:

- a. Remove the tops of bubbles using a fiberglass brush, orange stick, or other appropriate tool. Removal may be assisted by the local application of a small amount of toluene applied under the supervision of the cognizant Process Engineering activity.
- b. Fill broken bubbles by coating the area with Type I, Formulations II, III, or Type II coating applied with a soft bristle brush.
- c. Cure the coating in accordance with 3.4.10.

PAGE	REVISED	REVISION
-	AP 12-17	D

**HUGHES STANDARD**

SMALL PARTS (100000)

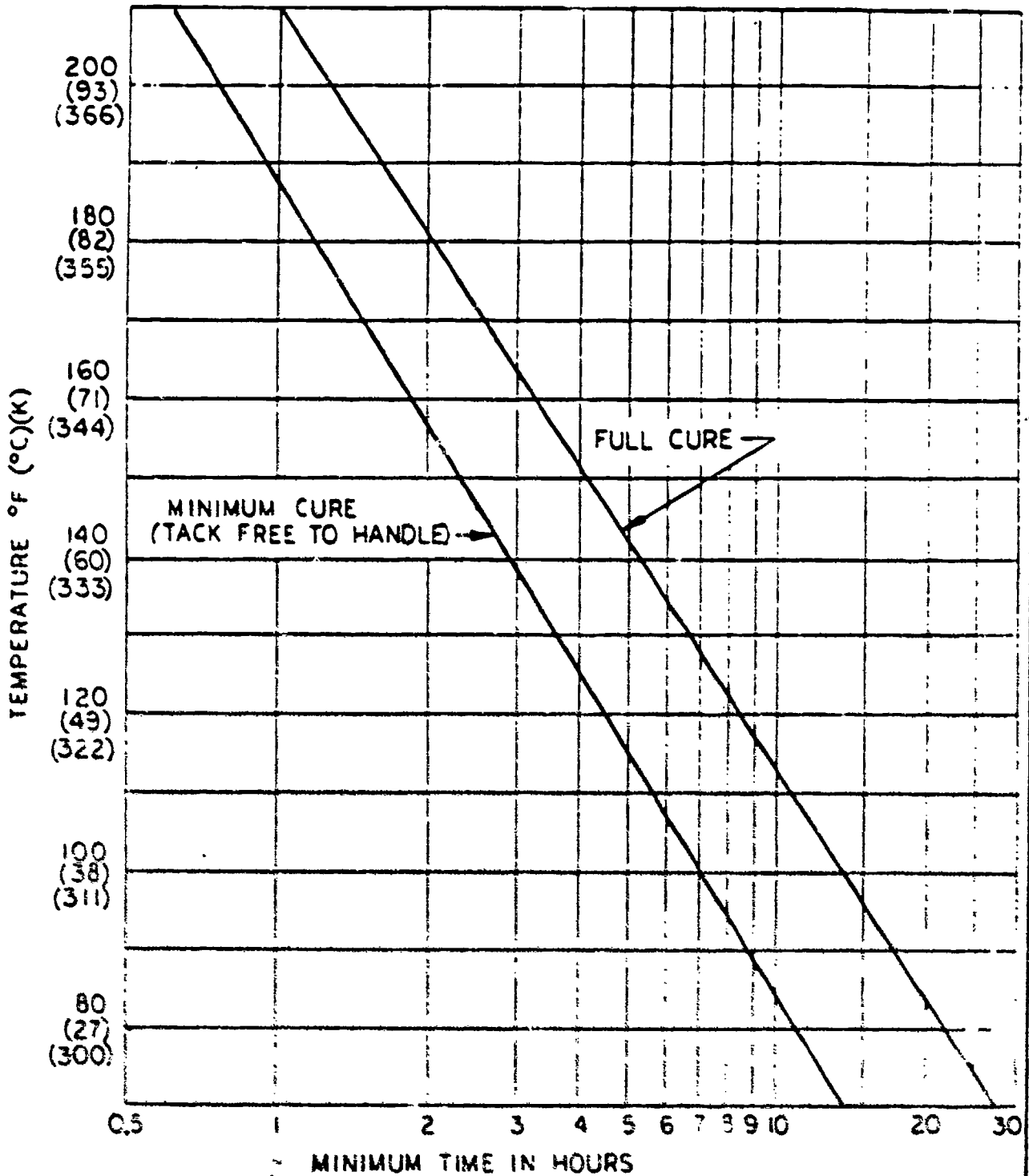

FIGURE 1. CURE CYCLE

The temperature shall be accurate within  $\pm 10^\circ\text{F}$  ( $\pm 5^\circ\text{C}$ ) ( $\pm 6^\circ\text{K}$ ) but shall not exceed the range shown. Elevated temperature cure may be accomplished in an air circulating or infrared oven. When a different temperature is used to complete the cure than that used to achieve handling strength, the minimum time to cure can be determined by subtracting the time to handling strength at the new temperature from the time to cure at the new temperature.

PAGE	REVISED
3	SEP 16-70
	0

**HUGHES STANDARD**

.....  
.....

3.4.12 Replacing coating. When a component must be replaced, the coating shall be removed and the area touched up as follows:

- a. Soften the coating under and around the component by prewarming the assembly at 150 to 210 °F (66 to 99 °C) (339 to 372 K) for at least 10 minutes. Using an orange stick, remove the coating before it rehardens. The coating removal may be assisted by the local application of a small amount of toluene or 1,1,1-trichloroethane applied under the supervision of the cognizant Process Engineering activity. As an alternate procedure, the coating may be removed carefully using a hot knife, with or without prewarming of the assembly.
- b. Repeat step a. as necessary and remove the component.
- c. Clean assembly in accordance with 3.4.2 after the component has been replaced.
- d. Coat the uncoated area and component by brush application of Type I, Formulations II, III, or Type II coatings.
- e. Cure the coating in accordance with 3.4.10.

3.4.13 Maskant removal and cleanup. After the coating has been cured, masking material and adhesive residue shall be completely removed. All flash material shall be trimmed off to the required contour and sharp or ragged edges removed. Care shall be taken to avoid cutting or damaging the assembly or peeling the edges of the coating.

4. QUALITY ASSURANCE PROVISIONS

4.1 Quality conformance inspection. Quality conformance inspection comprises all of the tests performed on individual lots which have been submitted for acceptance. The tests are described in the following subparagraphs:

4.1.1 Sampling for quality conformance. All parts shall be 100 percent inspected.

4.1.2 Inspection. Inspection to determine compliance with the characteristics specified in Table III shall be conducted in accordance with the corresponding test and inspection paragraphs.

TABLE III. QUALITY CONFORMANCE INSPECTION

Characteristics	Requirement Source	Test and Inspection Paragraph
Workmanship	3.1.1	4.2.1
Coating thickness	3.1.2	4.2.2
Packaging	5.1	4.2.1

PAGE	REVISED
3	82 16-171

# HUGHES STANDARD

## 4.2 Test methods and procedures

4.2.1 Visual examination and inspection. The assemblies shall be visually inspected for conformance to the workmanship requirements in 3.1.1 and packaging requirement specified in 5.1. In addition, inspection for completeness of coating shall be performed by examining the assembly under ultraviolet light in a dark area. Coated areas will have a blue glow. Areas to be inspected shall include component leads, circuitry, and solder tips and joints.

4.2.2 Coating thickness. The coating thickness shall be measured using a calibrated tool or instrument (such as a micrometer caliper or a light section microscope) to establish conformance to the requirements of 3.1.2.

## 5. PREPARATION FOR DELIVERY

5.1 Packaging. The coated and finished assemblies shall be placed in a plastic box or other suitable container to prevent damage or contamination.

## 6. NOTES

6.1 Intended use. This process is intended to provide a finished and cured coating that will provide flexibility with good adhesion and insulation characteristics. The coating lends itself to repair with hot knife techniques and may be removed sufficiently from solderable surfaces for subsequent soldering by prior heating of the joint. The coating may be applied directly onto glass bodied components without the need for sleeving the component. Cured coating is not resistant to solvents such as acetone, methyl ethyl ketone, toluene, 1,1,1-trichloroethane and trichloroethylene. Immersion for 2 minutes will cause coating to swell and lose adhesion.

Type I. Formulation I is for general application by spray to secure overall uniform coverage over flat surfaces as well as over protruding surfaces such as leads and component bodies. It does not form a fillet around component bodies. This coating serves as an undercoat for Formulation II.

Type I. Formulation II is for general application by dipping or pouring. It gives good coverage over flat surfaces and forms an excellent fillet around component bodies. It does not cover protruding surfaces well. This coating serves as an overcoat over Formulation I.

Type I. Formulation III is for general application by brush for touchup and component replacement.

Type II is a one step coating process used for general application to secure uniform coverage over flat and protruding surfaces. Type II does not give as good a coverage as the Type I coating system over component leads and bodies.

6.2 Silicone materials, including RTV's, can contaminate direct contact areas as well as adjacent areas. Use of these materials as processing aids should be avoided.

**HUGHES STANDARD**

**RELEASE AND REVISION RECORD**

Rev	Authority	Description	Release	
			Date	Approval
A thru B	—	Records of changes are contained in the document history file.	—	—
C	CMER 17547	Extensively revised to incorporate Type II coating system.	7-27-78	<i>N. J. Thum</i> D. Guritz
D	CMER 17806	P2: Para 2.2, added EMS 16-2105. Revised 3.1.1.1 P3: Table I, added frozen premix, two-component kit, and note 1/. Renumbered following pgs. P5: Table II, added note 5/. Revised footnote 2/. P6: Para 3.4.8, added provision to add solvent. Revised 3.4.6.1. P7: Revised 3.4.9 and added note. P9: Para 3.4.12a, added "or trichloroethane".	4-25-79	<i>H. W. N...</i> <i>(for a. G...)</i> P. McGuinness
G-13			PAGE 12	REVISION D

APPENDIX H. DETAILED UV CONFORMAL COATING  
PROCESS - HUGHES SCG

**HUGHES**

HUGHES AIRCRAFT COMPANY  
SPACE AND COMMUNICATIONS GROUP

DIVISION 45

**MANUFACTURING ENGINEERING INSTRUCTION**  
UV CURED CONFORMAL COATING OF  
PWB ELECTRONIC ASSEMBLIES

MEI NO. 1.16.39

PAGE 1 of 9

DATE 6/6/80

PREPARED BY: J.A. Tull

*J.A. Tull*

APPROVALS: F.R. Salmon

*F.R. Salmon*

E.A. Anderson

*E.A. Anderson*

J.R. Fay

*J.R. Fay*

W.M. Kendziorek

*W.M. Kendziorek*

ISSUE	DATE	APPROVALS	PARAGRAPHS AFFECTED
-------	------	-----------	---------------------

TABLE OF CONTENTS

		<u>Page</u>
1.0	GENERAL	4
1.1	Scope	4
1.2	End Use	4
2.0	PROCEDURE	5
2.1	Assembly Preparation	5
2.2	Coating Preparation	5
2.3	Spray Application	6
2.4	Curing of Coated PWB Assembly	6
2.5	Component Replacement	7
3.0	REQUIREMENTS	8
3.1	General	8
3.2	Equipment	8
3.2	Product Materials	8
3.4	Process Materials	8
4.0	APPLICABLE DOCUMENTS	9
4.1	MEL Specifications	9



## 1.0 GENERAL

1.1 Scope

1.1.1 This MEI describes the process for the UV cured conformal coating of exposed circuitry of electronic assemblies. The application method described is spraying.

1.2 End Use

1.2.1 This MEI is not for use on production hardware. Only Manufacturing Engineering Laboratory personnel are authorized to perform this process. The coating described here is in the development stage and is not approved for use on space hardware.

H-6

PAGE	REV
4	MEI 1.16.39

HUGHES AIRCRAFT COMPANY  
SPACE AND COMMUNICATIONS GROUP

- 2.0 PROCEDURE
- 2.1 Assembly Preparation
  - 2.1.1 If required, place the printed wiring board (PWB) assembly in holding fixture.
  - 2.1.2 Degrease the assembly per MEI 1.9.1. Do not touch areas to be coated. When handling clean parts, wear clean gloves or clean finger cots, use clean handling aids, or pick up the parts by their rigidizing fixtures or areas to be masked.
  - 2.1.3 Place the clean assembly on a clean Kaydry tissue and cover with a second Kaydry tissue to avoid airborne contaminants.
  - 2.1.4 Using the following materials, mask areas not to be coated as specified on the applicable assembly drawing: frame, masking cover, tube caps, tape or PC Flex Mask.
  - 2.1.5 If the PWB assembly is in a rigidizing frame, adjust the frame to mask the edge areas that are not to be coated.
  - 2.1.6 Irregular areas or terminals may be masked with PC Flex Mask. Apply and cure as specified in Table 1.

Table 1. Cure Time for PC Flex Mask

Temperature	Cure Time
Ambient	60 minutes minimum
160 $\pm$ 10°F	30 minutes minimum
200 $\pm$ 10°F	15 minutes minimum

- 2.2 Coating Preparation
  - 2.2.1 NOTE: All mixing must be done in spray booth. Use a metal or plastic stir rod, or tongue depressor to blend material. Do not degas.

Formulate the coating using the mix ratios listed in Table 2.

PAGE	REV
5	MEI 1.16.39

Table 2. Coating Formulations

Material	Amount Formulated
Hughson RD3650-21	100 pbw
Butyl Acetate	27 pbw

Using 27 pbw as the starting point, add additional butyl acetate to facilitate spraying.

2.3 Spray Application

2.3.1 CAUTION: Put on rubber gloves, protective smocks, and eye protection. Spraying must be done in spray booth.

Set air pressure to 30  $\pm$ 10 psi and adjust spray gun to fine light fan. Hold the assembly at about 45° and spray across the assembly with slow steady sweeps. Spray rear of PWB only.

2.3.2 Rotate assembly 90° and repeat the spray operation. Continue until all four sides have been coated.

2.3.3 Spray the PWB from vertical position.

2.3.4 Visually examine the coated assembly and spray as necessary to completely coat required areas.

2.3.4.1 Air dry 15  $\pm$ 2 minutes.

2.3.5 Cure rear of assembly in accordance with 2.4 minimum handling cure.

2.3.6 Coat the front side of assembly. Repeat 2.3.1 through 2.3.4.

2.3.7 Cure front of assembly in accordance with 2.4 minimum handling cure. Full cure per 2.4.

2.4 Curing of Coated PWB Assembly

2.4.1 Cure for minimum handling by using oven scan setting 5 (low intensity). Repeat for second side.

2.4.2 To achieve full cure of shadowed areas cure in air circulating oven for 30 minutes minimum at 200  $\pm$ 10°F.

2.4.3 After full cure, remove all masking materials with tweezers.

- 2.5            Component Replacement
- 2.5.1        Cut component leads close to body of component.
- 2.5.2        Remove the fillet of conformal coating from around component body with a hot knife. Scrape off residual coating with orange stick.
- 2.5.3        Remove component from PWB.
- 2.5.4        Insure that solder pads are free of coating material. Remove per 2.5.2.
- 2.5.5        Install the new component onto the assembly.
- 2.5.6        Clean the assembly per MEI 1.9.1.
- 2.5.7        Dilute small amount of UV conformal coating material per 2.2.1 and Table 2.
- 2.5.8        Brush on small amount of material and cure per 2.4.

3.0 REQUIREMENTS

3.1 General

- 3.1.1 When measured on the flat areas of the board, the thickness of the coating shall be 0.0015  $\pm$  0.001 inch.
- 3.1.2 The coating shall have no blisters, peeling, or bubbles.
- 3.1.3 Continuity and coverage may be determined with the use of any ultraviolet light. Required areas shall be coated.
- 3.1.4 Areas under flat bottomed components which are mounted flush with the circuit board need not be coated.

3.2 Equipment

- Oven, air circulating Blue M Electric Co.  
Blue Island, IL
- Oven, Ultra Violet,  
Model BP720-1SPL Interpress Corp.  
Duarte, CA

3.3 Product Materials

- UV conformal coating,  
Hughson 3650-21 Hughson Chemical Co.

3.4 Process Materials

- Brush #2, camel hair MRO N70-0404
- Butyl acetate MCB BX1750
- Cotton smock Commercial
- Hot knife Commercial
- Orange stick MRO N60-2714
- PC Flex Mask, #2 heavy Contronic Services  
Westminster, CA
- Rubber gloves MRO N60-1260
- Stirring rod Commercial
- Tape, Teflon Commercial
- Tongue depressor MRO N60-1010

PAGE	REV
8	MEI 1.16.39

4.0 APPLICABLE DOCUMENTS

4.1 MEL Specifications

MEI 1.9.1

Cleaning of Electronic  
Parts and Assemblies

MEI 2.1.28

Operation of Ultraviolet  
Curing Oven

PAGE		REV
9	MEI 1.16.39	