

AD-A151 532

CAD/CAM (COMPUTER-AIDED DESIGN/COMPUTER-AIDED
MANUFACTURING) HIGHLIGHTS(U) ARMY INDUSTRIAL BASE
ENGINEERING ACTIVITY ROCK ISLAND IL D L RICHARDSON
OCT 84 SBI-AD-E700 014

172

UNCLASSIFIED

F/G 13/8

NL

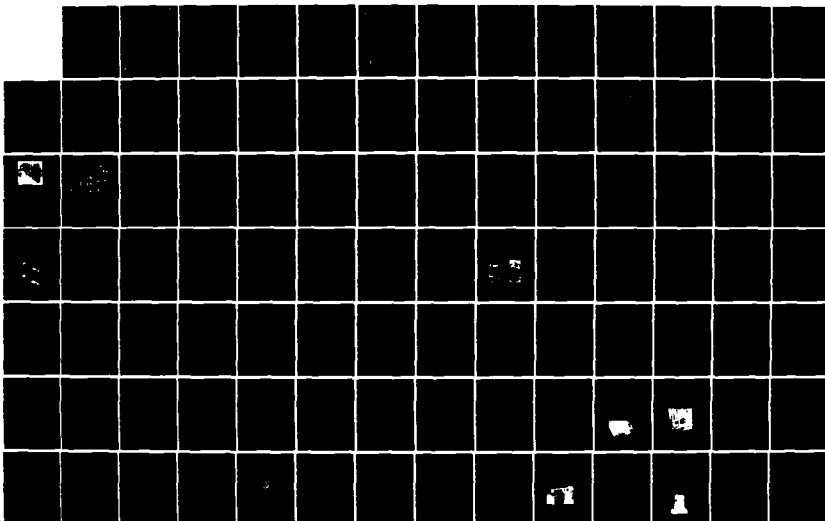

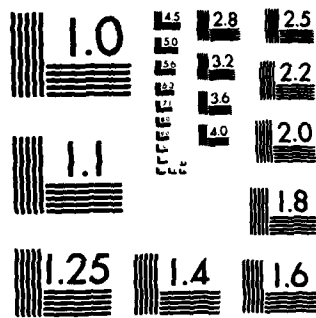

MICROCOPY RESOLUTION TEST CHART
NATIONAL BUREAU OF STANDARDS-1963-A

700014



AD-A151 532

US ARMY MATERIEL COMMAND

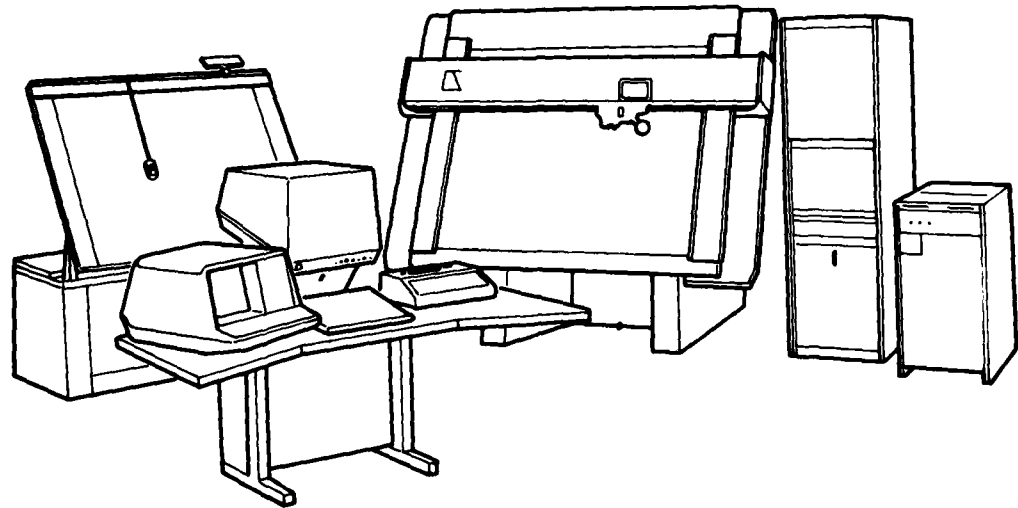

CAD/CAM HIGHLIGHTS

(FY 84)

DISTRIBUTION UNLIMITED; DOCUMENT FOR PUBLIC RELEASE

DTIC FILE COPY

PREPARED BY

OCTOBER 1984

USA INDUSTRIAL BASE ENGINEERING ACTIVITY

MANUFACTURING TECHNOLOGY DIVISION

ROCK ISLAND, ILLINOIS 61299-7260

S DTIC ELECTE **D**
MAR 5 1985

B

DISCLAIMER

This document presents information for the US Army Materiel Command (AMC) Computer-Aided Design/Computer-Aided Manufacturing Program.

The citation of trade names and names of manufacturers in this document is not to be construed as official Government endorsement or approval of commercial products or services referenced herein.

Neither the Department of Army nor any of its employees makes any warranty, expressed or implied, or assumes any legal liability or responsibility for the accuracy, completeness, or usefulness of any information apparatus, product or process disclosed, or represents that its use would not infringe on privately owned rights.

UNCLASSIFIED

SECURITY CLASSIFICATION OF THIS PAGE (When Data Entered)

REPORT DOCUMENTATION PAGE		READ INSTRUCTIONS BEFORE COMPLETING FORM											
1. REPORT NUMBER	2. GOVT ACCESSION NO. AD A151532	3. RECIPIENT'S CATALOG NUMBER NONE											
4. TITLE (and Subtitle) MANUFACTURING METHODS AND TECHNOLOGY CAD/CAM HIGHLIGHTS		5. TYPE OF REPORT & PERIOD COVERED Biennial Final Report											
7. AUTHOR(s) DANIEL L. RICHARDSON		6. CONTRACT OR GRANT NUMBER(s) N/A											
9. PERFORMING ORGANIZATION NAME AND ADDRESS US Army Industrial Base Engineering Activity Attn: AMXIB-MT Rock Island, IL 61299-7260		10. PROGRAM ELEMENT, PROJECT, TASK AREA & WORK UNIT NUMBERS N/A											
11. CONTROLLING OFFICE NAME AND ADDRESS US Army Industrial Base Engineering Activity Attn: AMXIB-MT Rock Island, IL 61299-7260		12. REPORT DATE October 1984											
14. MONITORING AGENCY NAME & ADDRESS (if different from Controlling Office) US Army Materiel Command Attn: AMCMT 5001 Eisenhower Avenue Alexandria, VA 22333-0001		13. NUMBER OF PAGES											
		15. SECURITY CLASS. (of this report) Unclassified											
		15a. DECLASSIFICATION/DOWNGRADING SCHEDULE N/A											
16. DISTRIBUTION STATEMENT (of this Report) This document has been reviewed for operations security (OPSEC). Distribution Unlimited													
<div style="border: 1px solid black; padding: 5px; display: inline-block;"> DISTRIBUTION STATEMENT A Approved for public release; Distribution Unlimited </div>													
17. DISTRIBUTION STATEMENT (of the abstract entered in Block 20, if different from Report) Distribution Unlimited													
18. SUPPLEMENTARY NOTES N/A													
19. KEY WORDS (Continue on reverse side if necessary and identify by block number) <table style="width: 100%; border: none;"> <tr> <td>Army</td> <td>Manufacturing</td> </tr> <tr> <td>Automation</td> <td>Processing</td> </tr> <tr> <td>Computer Applications</td> <td>Systems Engineering</td> </tr> <tr> <td>Industrial Production</td> <td>Technology Transfer</td> </tr> <tr> <td>Management Engineering</td> <td></td> </tr> </table>				Army	Manufacturing	Automation	Processing	Computer Applications	Systems Engineering	Industrial Production	Technology Transfer	Management Engineering	
Army	Manufacturing												
Automation	Processing												
Computer Applications	Systems Engineering												
Industrial Production	Technology Transfer												
Management Engineering													
20. ABSTRACT (Continue on reverse side if necessary and identify by block number) <p>This document contains summaries of Army Computer-Aided Design (CAD) and Computer-Aided Manufacturing (CAM) efforts that are either completed or ongoing. The Army CAD/CAM Program funds efforts through a wide variety of sources and AMC programs.</p> <p>Significant information contained in this document was obtained from various management documents submitted to IBEA in the data collection cycle. AMC Major Subordinate Commands, Installations, Activities, and</p>													

20. Program Offices as well as defense contractors, are the sources for this management data. The summaries highlight the integration of computers in the materiel development and production environment. They are organized into eleven sections corresponding to system technology areas which are listed with their numerical classification below.

TECHNOLOGY
AREA NUMBER

TECHNOLOGY AREA TITLE

100	Architecture
200	Fabrication
300	Data Base/Data Automation
400	CAD/CAM Interaction
500	Planning and Group Technology
600	Manufacturing Control
700	Assembly
800	Simulation, Modeling and Operations Research
900	Materials Handling and Storage
1000	Test, Inspection and Evaluation
1100	Continuous Flow Processes



DEPARTMENT OF THE ARMY
 US ARMY INDUSTRIAL BASE ENGINEERING ACTIVITY
 ROCK ISLAND, ILLINOIS 61299-7260

REPLY TO
 ATTENTION OF:

AMXIB-MT

SUBJECT: Computer-Aided Design/Computer-Aided Manufacturing (CAD/CAM)
 Highlights

SEE DISTRIBUTION

1. Reference DARCOM-R 15-13, "DARCOM Computer-Aided Design/Computer-Aided Manufacturing (CAD/CAM) Steering Group," dated 14 March 1984.
2. The CAD/CAM Highlights presents summaries of Army CAD/CAM efforts that are either completed or ongoing. The Army funded these efforts through a variety of AMC Programs that promote productivity. The document was prepared under the auspices of DARCOM-R 15-13, and represents a compilation of efforts up to October 1984. Information presented was obtained from various management documents submitted to IBEA during the data collection cycle of this publication.
3. Comments on this material may be sent to Mr. D. Richardson, US Army Industrial Base Engineering Activity, AMXIB-MT, Rock Island, IL, 61299-7260. Additional copies may be obtained by written request to the Defense Technical Information Center, Attn: TSR-I, Cameron Station, Alexandria, VA, 22314.

FOR THE DIRECTOR:

James W. Carstens
 JAMES W. CARSTENS

Chief, Manufacturing Technology Division

S DTIC
 ELECTE **D**
 MAR 5 1985
B

Accession For	
NTIS SPA&I	<input checked="" type="checkbox"/>
DTIC TAB	<input type="checkbox"/>
Unannounced	<input type="checkbox"/>
Justification	
By PER CALL JC	
Distribution/	
Availability Codes	
Dist	Avail and/or Special
A-1	



TABLE OF CONTENTS

<u>TITLE</u>	<u>PAGE</u>
INTRODUCTION	1
HIGHLIGHTS	5
100 ARCHITECTURE	7
Electronics Computer Aided Manufacturing	9
200 FABRICATION	13
Flexible Manufacturing Systems	15
Robotic Shelter Refinishing	18
Automated Laser Beam Welding	20
Energy Adaptive Precision Grinding	23
300 DATA BASE/DATA AUTOMATION	27
Relational-Based Data Management System	29
400 CAD/CAM INTERACTION	33
CAD for Casting	35
Sacramento Army Depot CAD/CAM	38
Tobyhanna Army Depot CAD	41
Powder Metallurgy Preform CAD	43
500 PLANNING AND GROUP TECHNOLOGY	45
Group Technology for AMCCOM	47
Group Technology for Watervliet Arsenal	50
Group Technology for Rock Island Arsenal	52
Computerized Production Process Planning	54
600 MANUFACTURING CONTROL	57
Maintenance Shop Floor Systems	59
Projectile Manufacturing Control	63
Factory Automated Communication System	65
700 ASSEMBLY	69
Automatic Hybrid Die Bonder	71
Robotic Wire Harness Assembly	73

TABLE OF CONTENTS (Cont.)

<u>TITLE</u>	<u>PAGE</u>
800 SIMULATION, MODELING AND OPERATIONS RESEARCH	77
Simulation of Metal Forming	79
REARM Production Line Simulation	82
Simulation of Ammunition Production Lines	84
900 MATERIALS HANDLING AND STORAGE	87
Depot Automatic Storage and Retrieval System	89
1000 TEST, INSPECTION AND EVALUATION	93
Integrated Blade Inspection System	95
Automatic Inspection Device of Explosive Charge in Shell	98
Automatic Infrared Test and Inspection System	101
Computerized Color Matching System	103
Ultrasonic Tire Inspection	105
Weld Arc Spectrum Analyzer	107
1100 CONTINUOUS FLOW PROCESS	111
Continuous Multi-Base Propellant Production	113
Continuous Process Control Feedback	116
APPENDICES	119
A Interactive Graphics Inventory	A1
B Numerical Control Tool Inventory	B1
C Robotics Inventory	C1
D CAD/CAM Steering Group Members	D1
E MTAG CAD/CAM Subcommittee Members	E1
F DISTRIBUTION	F1

INTRODUCTION

The CAD/CAM Highlights is a collection of technical articles describing ongoing or recently completed efforts by the Army to implement computer technology. These articles accentuate the successful achievements of Army organizations. The objective of this publication is to promote the development and use of computers in the design, production and management of Army materiel. Hopefully, this document will enhance management awareness and promote information exchange.

The CAD/CAM efforts described in this document are divided into eleven technology categories. These categories were originally developed by the Air Force Integrated Computer Aided Manufacturing (ICAM) Program model and later refined by the Computer and Automated Systems Association (CASA) of the Society of Manufacturing Engineers and the DOD Manufacturing Technology Advisory Group, CAD/CAM Subcommittee. A synopsis of these categories is provided on the next page.

Also included in this document are the results of surveys which attempted to identify Army's inventory of Interactive Graphic Systems (Appendix A), Numerical Control Tools (Appendix B), and Robotic Equipment (Appendix C).

The AMC CAD/CAM Steering Group is responsible for coordinating Army CAD/CAM efforts. This group is also responsible for the preparation of the AMC CAD/CAM Program Plan. Objectives for the AMC CAD/CAM Steering Group include: developing strategic plans, establishing ad hoc working groups, and recommending revision to CAD/CAM policy. Each of the working groups has specific tasks with areas of emphasis in: System Engineering Methodology and Training, Computer Aided Engineering, Manufacturing Systems Integration, and Configuration Management of Systems. The CAD/CAM Steering Group membership is provided in Appendix D.

On a tri-service basis, the Army has taken an active role in the CAD/CAM Subcommittee of the Manufacturing Technology Advisory Group (MTAG). The Army chairs this subcommittee and participates with other government agencies, industry and professional societies. The MTAG CAD/CAM Subcommittee provides Government wide coordination of MMT CAD/CAM Related Projects and provides a forum for the exchange of information on these efforts. The MTAG CAD/CAM Subcommittee membership is provided in Appendix E.

COMPUTER AIDED DESIGN/COMPUTER AIDED MANUFACTURING TECHNOLOGY CATEGORIES

100 ARCHITECTURE

The purpose of the manufacturing architecture is to provide a clear understanding of the manufacturing environment and the interrelationships between subsystems that exist today. The manufacturing architecture, or framework, provides a common baseline in building integrated manufacturing systems. It establishes the structure into which the other ten technology areas will be integrated.

200 FABRICATION

The fabrication technology area serves as a focus for all other technology area activities. Projects categorized into this area are directed toward increasing the productivity of manufacturing by systematically applying computer technology to all functions which directly and indirectly participate in fabricating parts.

300 DATA BASE/DATA AUTOMATION

The thrust area of data base and data automation is for technology required to support integration of the many stages and disciplines of manufacturing.

400 CAD/CAM INTERACTION

The purpose of this technology thrust area is to establish subsystems and procedures which will integrate the efforts of product design and manufacturing. The underlying concept is that of a common data base between engineering and manufacturing.

500 PLANNING AND GROUP TECHNOLOGY

This technology is directed at optimizing process planning, production scheduling and control, factory layout and other tasks normally performed by indirect personnel that have a significant impact on manufacturing cost.

600 MANUFACTURING CONTROL

Manufacturing control is generic technology for producing management oriented information tools for scheduling, monitoring and controlling operations within the manufacturing environment. This thrust area is closely related to the fabrication and planning and group technology areas.

700 ASSEMBLY

Briefly stated, this thrust area integrates computer aided technology into assembly operations.

800 SIMULATION, MODELING AND OPERATIONS RESEARCH

Simulation, modeling, and operations research is soft technology for optimizing manufacturing systems through the application of operations research techniques.

900 MATERIALS HANDLING AND STORAGE

This thrust area concerns the integration of computer aided technology to aid in material handling. Objectives here include complying with OSHA and EPA standards and reducing costs and materials handling time through automated material storage, handling, and retrieval systems.

1000 TEST, INSPECTION AND EVALUATION

The purpose of projects in this thrust area is to develop and transition real time, computerized, nondestructive testing techniques for use in fabrication and assembly operations. Emphasis is put on automatic, in-process inspection and decision making without human intervention.

1100 CONTINUOUS FLOW PROCESSES

This technology area addresses the range of manufacturing processes that, for the most part, are continuous with minimum human interaction.

HIGHLIGHTS

100 ARCHITECTURE

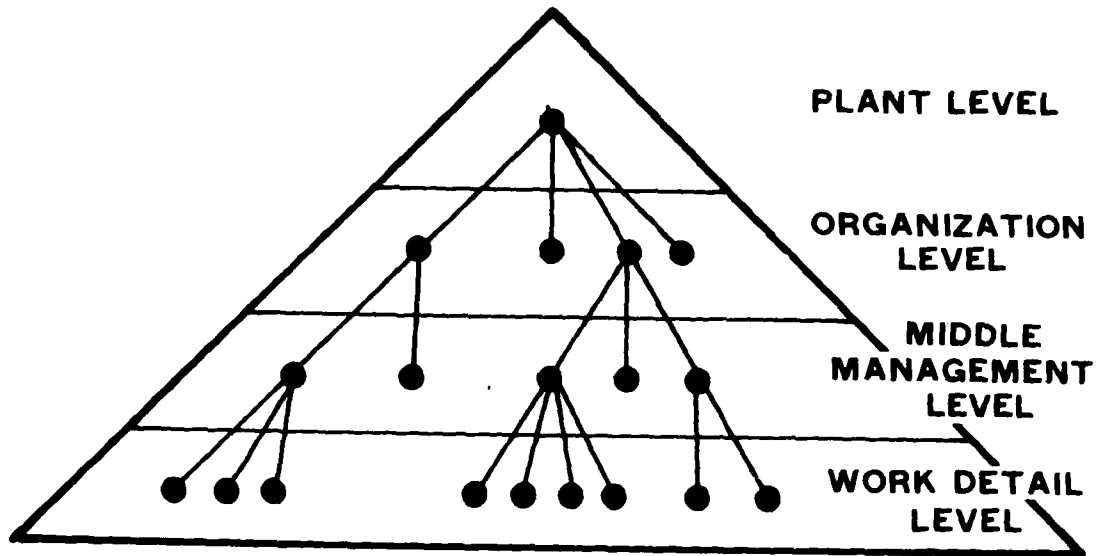

To clearly define the purpose of manufacturing architecture, the theory is to provide a clear understanding of the manufacturing environment and the interrelationships between subsystems that exist today. The manufacturing architecture, or framework provides a common baseline upon which integrated manufacturing systems can be built.

The architecture provides an installation, a plant, or management level, a framework into which individual modules of CAM accomplishments will be integrated for total disciplined manufacturing operation and control. An example of the framework is illustrated for several levels of the manufacturing operation in the above figure.

The integration of all levels of CAM from the work detailed level to the top management or facilities level is not an easy task to accomplish. Total integration requires persistent visualization of each subsystem into a hierarchial framework of all subsystems.

ELECTRONIC COMPUTER AIDED MANUFACTURING

An industry review found that automation and computer control techniques are used extensively in the manufacture of high volume consumer products, but are applied to a much lesser extent to the manufacture of military equipment. The products manufactured for the military are extremely diverse and have characteristics which differentiate them from consumer and industrial electronic products. For instance, one of a kind production is not unknown and production of a few dozen units per year is relatively common.

For the maintenance of DOD's industrial base, it was determined that a type of automation which can be quickly and cheaply redirected from one product to another was needed. This is sometimes called "flexible automation" as opposed to "fixed automation" which is used in facilities devoted for long periods to production of a single product.

Many firms producing electronic equipment for DOD have computer-aided design (CAD) and computer-aided manufacturing (CAM) systems which help them in the layout of components. Most of the software systems are independent of each other, are written in different languages, and run on different computers. A few firms have developed interfaces on a sketchy basis, but are not tied in with manufacturing, inspection, or management information systems. A top-down approach was needed for a tighter coupling of CAD and CAM within a logical factory architecture (as shown below) utilizing group technology as the data base organizational concept.

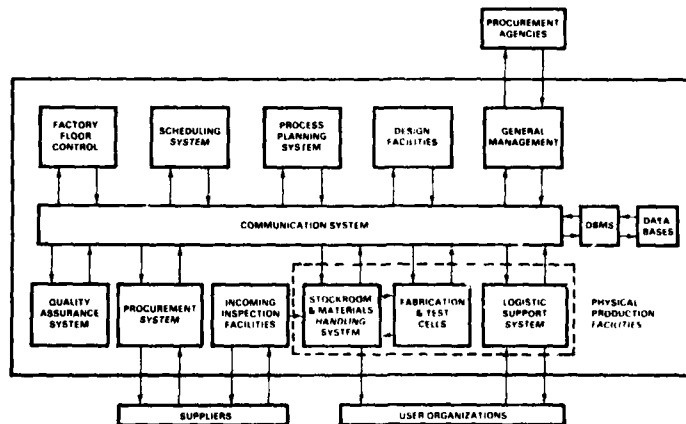

CONCEPTUAL EXAMPLE FACTORY STRUCTURE

The Electronic Industry Association formally asked DOD to undertake a project to identify the opportunities and advantages of applying flexible computer-integrated manufacturing to military electronics. The Electronics Computer-Aided Manufacturing (ECAM) program, managed by the US Army Missile Command (MICOM), was initiated in response. The Army funding contribution came from MMT effort 3-1075. The objective of this effort was to produce a master plan for Government investment and technology development to support computer-aided design, manufacture, and test of electronic equipment. This plan would be used to assist in managing the Army, Navy, and Air Force manufacturing technology programs in electronics over the next few years.

Battelle Columbus Laboratories was contracted to perform an investigation and define the scope of the problem, determine what DOD projects were already surveying the area, and develop an architecture for a generalized computer controlled system for the manufacture of electronics. The program was a concentrated development effort with higher factory level functions common to those established by the Air Force's Integrated Computer-Aided Manufacturing (ICAM) program. Battelle developed a Master Plan of actions to be taken, identified software needs, established an architecture of "As Is" and "To Be" factory models, and developed descriptions of additional tasks required.

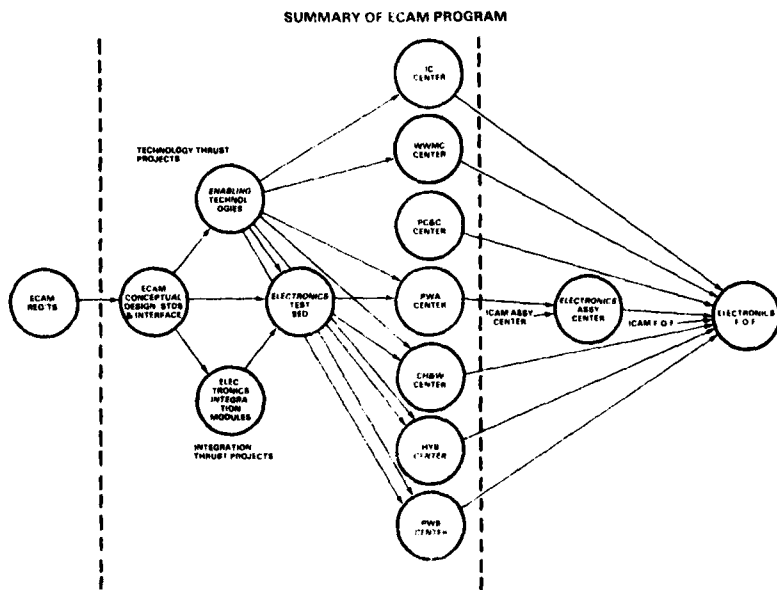

Battelle established an ECAM Coalition which sought advice from a broad base that included more than 180 people from Government agencies, academia, non-profit associations, trade associations, and technical societies. Each firm in the coalition developed information for several of seven basic commodity areas. These are: (1) panels, covers, and chassis; (2) cables, harnesses, and wiring; (3) printed wiring boards;

(4) integrated circuits; (5) hybrid microelectronics; (6) wirewound magnetic components; and (7) electronic assemblies. A preliminary analysis of current design and manufacturing practices for the seven electronic commodities was performed. The main products of the commodity groups were process diagrams which describe "As Is" factory arrangements and other diagrams which show "To Be" factory arrangements.

The coalition has completed the analysis and planning phase of the ECAM effort. It represents a consolidation of ideas, technical know-how, recommendations, and expressed needs from 16 major companies working in close cooperation with the representatives of the Army, Navy, and Air Force. It has resulted in a definition of the entire process of design, manufacture, and test of military electronics equipment and a recommended Master Plan for Government action.

Each service has agreed to concentrate its future efforts on certain commodity areas for the development of the enabling technology under the auspices of the Master Plan. The implementation of this modular technology will be achieved in ongoing and future electronic factories in a bottom-up fashion. The required integration is to be achieved through guidelines and standards in certain key technological areas. The areas considered to be the most important are data bases, communications, interfaces, software languages, and perhaps operating systems.

Additional information may be obtained from Mr. Gordon Little, US Army Missile Command, AMSMI-RST, Huntsville, AL 35898, AUTOVON 746-3604 or Commercial (205) 876-3604.

200 FABRICATION

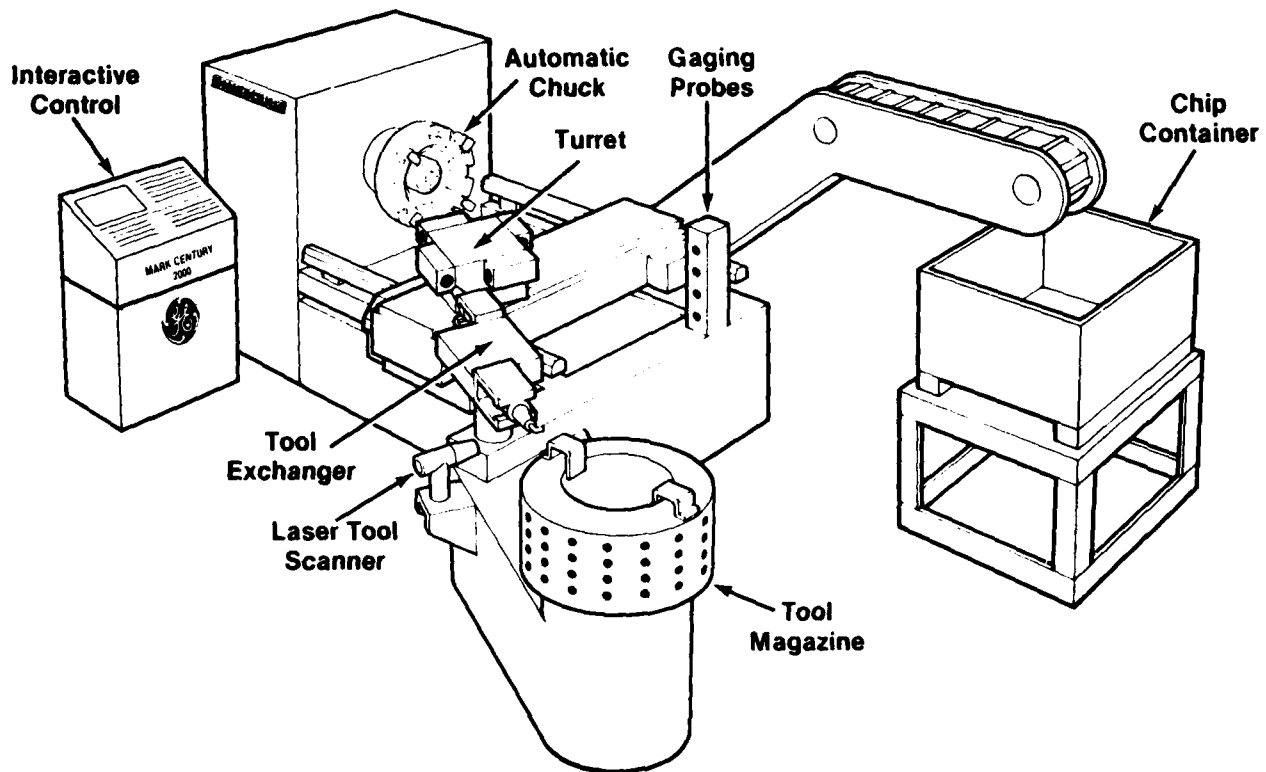

Computer Controlled Machine Tool

Efforts categorized into this area are directed toward increasing the productivity of manufacturing by systematically applying computer technology to all functions which directly and indirectly participate in fabricating parts. Specifically, this area encompasses improved computer and sensor implementation through algorithm development for the real-time analysis and control of fabrication processes. It also embraces the modular concepts of fabrication such as Flexible Manufacturing Systems and Machining Centers. This technology area is the lowest tier in the Factory of the Future architecture and serves as the focal point for the other technology areas.

FLEXIBLE MANUFACTURING SYSTEMS

Flexible Manufacturing Systems (FMS) offer a means to capitalize on the economics of mass production techniques without sacrificing all the flexibility inherent in general purpose stand alone equipment. A conceptual FMS is shown below. FMS is a relatively new concept integrating three primary elements: work stations, material transport, and automatic control. Justifying, purchasing, and optimal operation of FMS presents unique problems not common to stand alone equipment. Significant up-front engineering is required to address the systems engineering and integration aspects.

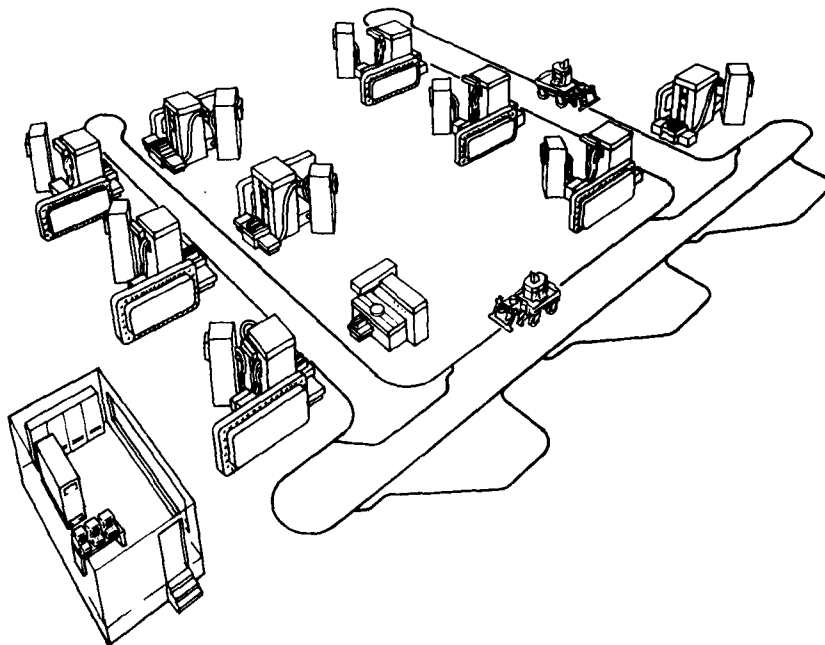

Conceptual FMS Setup

In order to provide a guide and approach to these problems and encourage DOD contractor investment in FMS, the US Army Tank-Automotive Command (TACOM) executed MMT Effort T-5082. The goal was to develop a multi-volume handbook that describes:

- o The need for and advantage of FMS
- o The technology of a typical FMS
- o Detailed advice on acquiring, installing, and operating an FMS
- o Preparation of request for proposals (RFP) for FMS
- o Case study of an FMS

During the development of the handbook, Draper Labs maintained coordination with a number of defense contractors and Rock Island Arsenal (RIA) to ensure wide applicability. Upon completion of the handbook, Draper Labs gave analytical support to the defense contractors and Rock Island Arsenal in determining their needs for FMS.

Draper Labs developed six software modules which provide the capability to simulate many of the dynamics of an FMS machining system. A data base was established from which various configurations of an FMS could be created and simulated. Cutting speeds and feeds by material type were defined for the machining processes along with operating parameters for each type of machine.

Preparing process plans for each part is complicated because a part may have multiple processing methods that vary according to the type of machine being used. This significantly increases the number of FMS configurations that can be created. Fixturing and tooling requirements were established for each part to facilitate simulation.

From the data base, machine time for each part was generated. This data was used with production rate variables to generate information to determine the approximate number of machines necessary to meet the selected production rate. Configuration of the system was further assisted by a batching and balancing algorithm that allocated parts to specific machines based on the number of tools used by the part, part cycle time, and tool capacity of the machine.

The simulation model was able to establish system throughput, as well as utilization of the machine tools, material handling carts, and load/unload stations. Analysis of these simulations significantly increased insight into the FMS approach. Machine requirements based on part processing methods can now be better understood. As the impact of production rate changes were more accurately determined, confidence in establishing system size and cost increased. Productivity of the system was equal to or greater than dedicated and special purpose machining alternatives. Opportunities for improving the FMS configuration by changing part processing methods, fixturing, and tooling were identified.

With Draper Labs simulation software and analysis, FMC Corporation has developed plans for the implementation of an \$8 million FMS. The FMS will initially turn out a family of seventeen parts for the drive train and chassis of the Army's Bradle Fighting Vehicle. Initially, four Cincinnati Milacron Model 20HC CNC machining centers will perform twenty-three machining operations, but three more will be added later. The entire FMS will be managed by two DEC PDP 11/24 minicomputers under the control of a DEC PDP 11/44 minicomputer. These will control the operation of the CNC coordinate measuring machine and the Eaton-Kenway automatic wire-guided vehicle system. The software consists of Cincinnati Milacron modules for work-order processing, fixture staging, load/unload staging, parts routing, vehicle traffic management, remote job entry, batch scheduling, and system operation simulation.

In addition to the Draper software, Hughes Aircraft augmented the software with executive control, data base communications, and management software. This software has been named FLEXPLAN. The executive software enables communication between the FMS and Hughes CAM Center's HP 3000, where the simulation and optimization modules reside. Using the executive, the FMS operator is able to describe situations and problems that he faces and must make decisions on. It allows the operator to make graphical displays of system status information, resource allocation, etc., as well as generate a number of different reports.

The predictive side of FLEXPLAN includes a detailed simulation which mimics the major activities of the system and tracks the important measures of performance to provide reliable answers to a variety of "what if" questions that the operator might pose. Another module also performs simulations of the FMS, but only assesses steady-state behavior of the system, using less computer time to yield system performance information.

A seventh module will be available to management to determine if the system is being underutilized and which parts are the most economically attractive to have manufactured by the system. It is a tool that assists management in analyzing all options and making the best selection.

RIA is investing in a multimillion dollar renovation of its armament manufacturing facilities (Project REARM), a significant portion of which involves replacement of obsolete metal cutting machine tools. Selection of the most appropriate configuration for these machine tools (stand-alone or integrated into an FMS) will keep production costs as low as possible and increase mobilization response capabilities. Draper Labs has been assisting in determining whether an FMS is an economically attractive investment.

The development of the fixturing concepts and detailed process plans for 53 of RIA's FMS compatible parts has been completed. Based on these process plans and Draper Lab's FMS simulation programs, an FMS consisting of four machining centers, one vertical turning center, one inspection robot, and two load/unload stations was recommended. The simulation is being rerun with revised input parameters; however, the recommendation that an FMS is economically justifiable will probably stand. A small portion of the work for RIA is being funded by MMT Effort T-5082 with the remainder of work funded by MMT Effort 6-8416. This effort is also related to MMT Effort 6-8400 which will develop special tooling methods that will be incorporated into the operation of RIA's FMS.

Additional information is available on the TACOM effort and contractor implementation by contacting Mr. David Pyrcce, TACOM, AUTOVON 786-5814 or Commercial (313) 574-5814 and on the RIA implementation by contacting Mr. John Wilkins, Rock Island Arsenal, AUTOVON 793-5897 or Commercial (309) 794-5897.

ROBOTIC SHELTER REFINISHING

The manual method of sanding and spray painting aluminum skinned military containers currently in use at Tobyhanna Army Depot (TOAD) exposes personnel to an unpleasant and unhealthy environment. Even with self-contained breathing apparatus, the jobs are difficult to perform and impose an exceptional hardship on the personnel involved, especially with the increasing use of polyurethane paints. In addition, the camouflage painting operation is difficult, requiring workers to draw the camouflage pattern on the shelter surfaces manually with chalk and number the appropriate areas according to a set pattern. Workers must continually change the paint colors to match the pattern.

Under MMT Effort G-0002, TOAD let two contracts to develop an automated robotic shelter refinishing capability. Robots, such as the one depicted below, can replace manual labor in undesirable environments. The MRC Corporation developed the automated sandblast cleaning workstation design package, system specifications, and standard operating procedures. El Dorado Engineering, Incorporated developed the robotic spray painting work station design package, system specifications, and standard operating procedures.

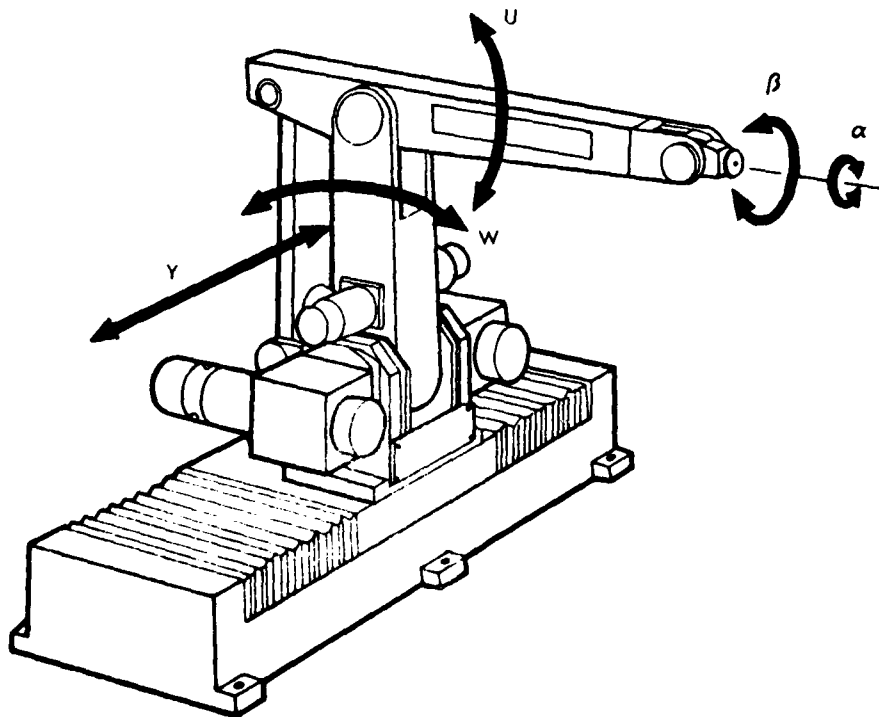

Degree of Freedom for Typical Robot

During the operation of the automated blast cleaning workstation, the shelter enters the workstation area by way of an overhead crane, and is loaded and properly aligned onto a scissors lift platform support frame. The combined motions of the scissors lift platform, the robot positioning

devices, and the robots facilitate the shelter cleaning. The robots travel on vertical tracks along the length of each side of a shelter. The scissors lift platform enables the robots to clean the shelter bottom in the highest position and to clean the top in its lowest position. After the shelter is blast cleaned, the operator enters the workstation to perform a manual vacuum clean-up operation, using medium recovery vacuum attachments. The shelter is then unloaded with the overhead crane to the staging area for removal from the workstation. The open work area is then vacuumed for recovery of medium. Provisions will be available in programming of the system so that portions of a shelter can be done separately without having to blast clean the entire surface.

During the operation of the robotic painting workstation, each shelter is loaded by an overhead hoist onto an air-powered dolly. The dolly runs on a track which enters the side of the paint booth. The dolly moves onto a turntable, straddling a lift table. The combined motions of the turntable, lift table, robot positioning device, and the robot facilitate the shelter painting. The robot travels a vertical track along the length of the shelter. The lift table in its highest position allows access to the shelter bottom, and in its lowest position, to the shelter top. The painted shelter exits the booth and is lifted off the dolly by the overhead hoist which loaded it. An automatically controlled paint supply and solvent flush system provides color changes. A mezzanine-mounted control booth allows an unobstructed view of operations in the booth.

The procurement and implementation phase of the sand blast workstation is currently unfunded, but the robotic spray painting workstation is currently in contracting. The use of an automated robotic workstation for spray painting aluminum shelters is expected to yield the following benefits: (1) The elimination of worker exposure to the unpleasant and unhealthy atmosphere of these operations; (2) Increased productivity by use of a more efficient and continuous process, elimination of the manual camouflage tracing operation, and increased equipment usage; (3) Improved quality of painting due to greater consistency of application.

Additional information is available by contacting Mr. Frank Estock, TOAD, AUTOVON 795-7099 or Commercial (717) 894-7099.

AUTOMATED LASER BEAM WELDING

The Lycoming AGT 1500 Turbine Engine which powers the Army's Abrams Main Battle Tank, derives its specific fuel efficiency from its recuperator. This is a heat exchanger made of several hundred 0.008 in. plates. They are embossed with one of two patterns and, when stacked alternately, form both the circumferential air flow passages and the radial exhaust gas passages as shown below. Until recently, all joints were made by automated resistance seam welding. This method was selected as the best available during the original development of the recuperator. Because of seam welding's speed limitations, and the problems inherent in the use of contacting electrodes, the US Army Tank-Automotive Command (TACOM) initiated MMT Effort T-5085 to investigate the feasibility of laser beam welding, and to develop it as an improved method of joining. The goal of the program was to produce a totally automated laser facility to make these welds. Such a facility requires the integration of lasers with load/unload devices, automated welding stations, and controllers.

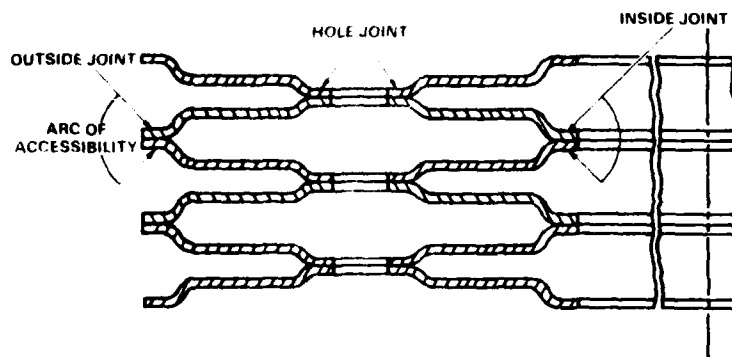

Recuperator Cross-Section

During the development of welding techniques and holding tools, it was found that the relationship between the beam track and the holding tool edge is critical. If the beam runs too close to the holding tool, energy is absorbed by the tool, and inadequate joint penetration results. However, the welding power required to join two plates is sufficient to cut the top plate if they are not held in contact. Therefore, the weld track must run very close to the holding tool yet must not run off the contacting area. This critical relationship was best maintained by fixing the welding tools under the X-Y table and indexing only the plates from hole pair to hole pair.

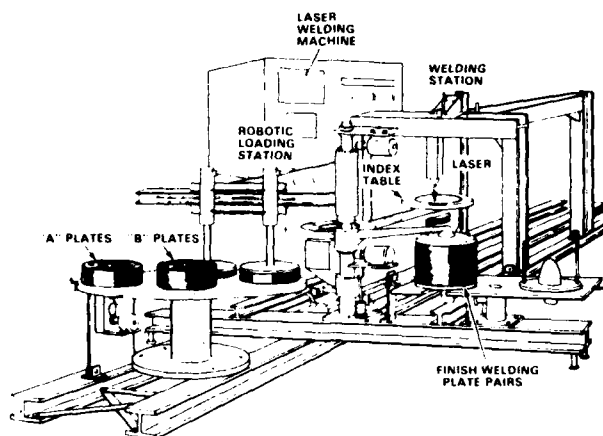

LASER WELDING STATION

Because the welding stations, shown above, must process thousands of parts per week, it was necessary to reduce as many mechanical functions as possible to software functions. For example, the index position of the part rotating table might be controlled by a solenoid-driven tapered pin but such devices usually cause problems. A better way is to use an optical encoder on the index drive motor shaft which allows the computer to lock the motor at exactly the desired position. This design concept was used throughout the system.

The high production rate dictated the selection of a carbon dioxide laser for this application; no other lasing medium is capable of operating at this production duty cycle. Most of the commercially available CO₂ lasers were investigated. Two were evaluated extensively -- a 2000W constant wave and a 525W pulsed mode laser. The choice was between using a single constant wave (CW) laser or two smaller pulsed lasers for a system of the desired production capacity. The CW laser was found to make acceptable welds at 1600W and 235 ipm. The pulsed laser makes an almost identical weld at 400W and 100 ipm. It was found, however, that plates welded with the pulsed laser were much less distorted than those welded with the CW laser. For this reason and the desirable redundancy, the two pulsed lasers were used.

The system has two Coherent pulsed CO₂ lasers, two welding stations, and two Allen-Bradley computer numerical controllers. Between them is a single load/unload robot. Each station controller calls the robot, which has no controller of its own, when required. Since manual loading and unloading of the welding station is possible from the side opposite the robot, failure of the robot does not stop production. If one welding station is not operating, or is being manually loaded and unloaded in order to do part rework, the robot and the other station continue production.

The computer must assure that the resultant beam velocity is constant as the motors drive the mirrors around the joint path to control joint penetration. At speeds over 200 ipm, the time to calculate and transmit path and velocity corrections is not available for joints with small corner radii. If calculation in real time is used, following errors accumulate until control is lost. This problem was resolved by storing a precomputed ideal path in a buffer memory and utilizing the feedback signal to correct the beam track path.

The key system components were extensively tested by welding actual parts prior to specifying the final design. Rather than build the entire system, then start it and begin debugging, the key components of one welding station were built first and installed in a welding facility in the vendor's applications laboratory. A number of problems that could have been serious in the finished facility were found in this way and eliminated from the final design.

Benefits resulting from this project include decreases in expenditures for labor, electricity, water, and electrodes. A significant unit cost savings has been realized. Lower rework rates and higher quality welds were also obtained. This pilot production system is now operating on-line at Avco Lycoming.

Additional information is available from Mr. David Pyrcce, TACOM, AUTOVON 786-6722 or Commercial (313) 574-6722.

ENERGY ADAPTIVE PRECISION GRINDING

In the recent past, the better knowledge of materials and mechanisms has greatly improved the quality of grinding wheels and the usefulness of grinding machines, but basic grinding methodology has not changed. The separation of grinding wheel technology from grinding machine technology has prevented a view of grinding technology from systems viewpoint. As a result, precision grinders are notoriously slow and sensitive to operator skill. Multiple operations, metallurgical damage from heat build-up, and high wheel-wear rates are common user complaints. Scrap rate is especially critical due to the high value added since grinding is a final operation. These factors lead to high cost and low productivity.

Large caliber cannons require close machined tolerances on recoil slide surfaces. The only practical means of machining these surfaces is by cylindrical grinding. The problem of specifying the best process variables is not one that can be arrived at using handbook factors and calculations. Instead, the user determines grinding feed and speed standards empirically.

The objective of MMT Effort 6-8120 was to reduce the grinding process art to more of a science, and apply the results to gun tube recoil surfaces. The US Army Armament, Munitions & Chemical Command (AMCCOM) contracted Energy-Adaptive Grinding, Incorporated to conduct an engineering evaluation relative to the application of their patented adaptive control cold grinding process called Energy Adaptive Grinding (EAG) as shown below. In the EAG system, the controlled variables are power used, wheel velocity, metal-removal rate, grinding heat, and grinding time. The only parameter of interest that is not directly controlled is the wheel wear.

Energy-adaptive grinder

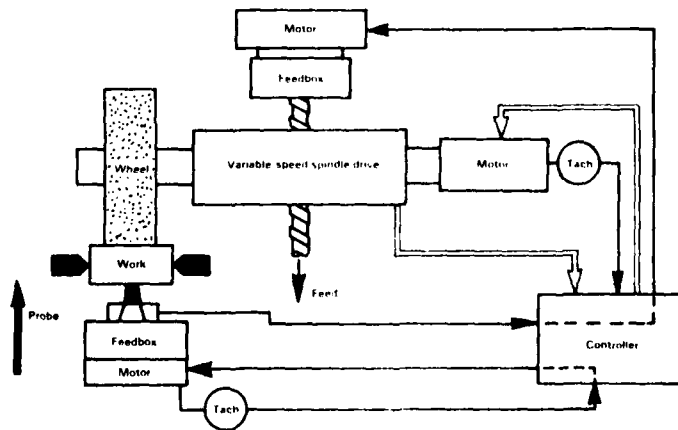

The conventional center-type cylindrical grinder with an added variable-speed spindle drive has a separate feed motor, feed drive, wheel system, and work-holding centers. The energy-adaptive cylindrical grinder uses these basic elements with improved control modifications.

The first additions--a work-surface eddy-current probe, a probe feedbox, the controller, and a closed-loop servo speed control with tachometer feedback--enable the probe to be fed toward the workpiece. Probe feedrate is selectable and held constant by means of the associated controller and the closed-loop servo.

The next addition is the wheel-feedrate control loop which is the closed-loop servo between the work-sensing probe, through the controller, to the wheel-slide feedbox motor. The loop operates in conjunction with the eddy-current probe. At the start of the grinding cycle, the probe makes a fast approach to the workpiece and then nulls its position at a specified gap. The controller directs the wheel-slide forward in a fast approach--until contact with the workpiece is sensed--and the grinding cycle starts. The probe is switched from a nulling mode, and it is moved toward the workpiece at a selected rate. This loop keeps the radius-reduction rate of the workpiece constant, and thereby the metal-removal rate.

The final addition to the system is the speed control of the wheel-spindle motor. This closed loop from the spindle drive to the controller to the spindle motor, provides speed control based on the net power. A software program lowers the speed of the drive when the upper limit is exceeded and raises speed when the power goes below the lower limit. This final circuit controls the specific energy with which the wheel face is cutting and therefore controls the wheel-face sharpness.

Other additions to the system provide safety, size-control functions and automatic sequencing normally associated with modern numerically controlled grinders. A size-control feedback, for example, is attached to the probe system. When the circuit senses that programmed final size is approaching, the probe is switched from a gap-signalling mode back to a measuring mode. The probe then continues with creep feed until the part is at final size. Position feedback enables wheel-slide retraction at the end of the grinding cycle.

Another addition is the wheel-overspeed safety control necessary with a variably controlled spindle. Wheel speed can be entered into the controller within a certain range. If a fault occurs, the controller shuts the grinder down. A redundant system senses loss of tachometer signal and monitors actual speed vs directed speed.



Retrofitted EAG Grinder

The energy adaptive machine, like the one above, puts the operator's skill into the grinder, and makes the industrial engineer's job of estimating grinding time and providing standards easier. Because of this, scrap problems relating to heat variations and grinding-wheel variations can be minimized.

The results of the evaluation indicate that adaptive control technology for grinders should be pursued. A conventional production grinder will be retrofitted with the new control technology for further evaluation at Watervliet Arsenal. A Cincinnati-Milacron grinder has been reserved for this project through DIPEC. A detailed specification for the retrofit work has been prepared and is being reviewed in-house.

Additional information is available from Mr. Ralph LeBarron, Watervliet Arsenal, AUTOVON 974-5590 or Commercial (518) 266-5590.

300 DATA BASE/DATA AUTOMATION

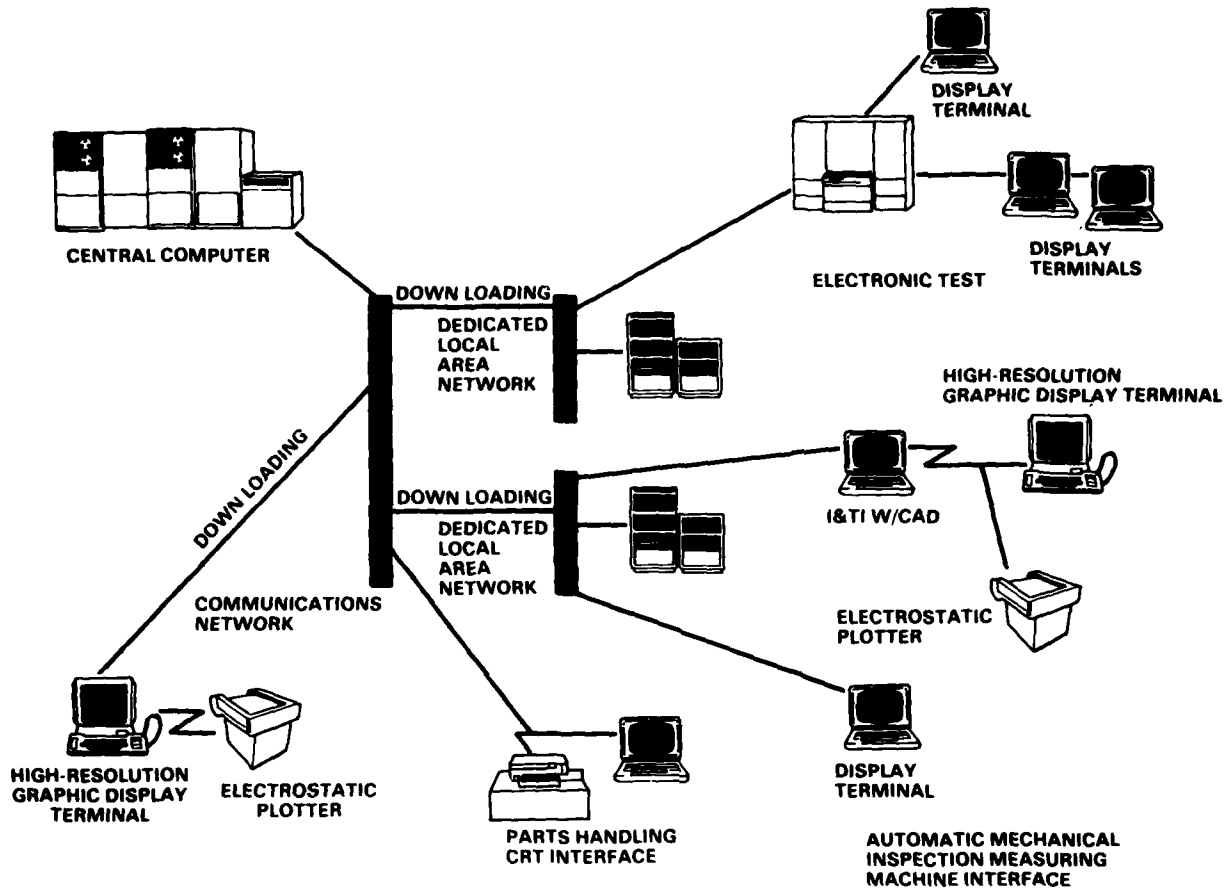

Data Network

The purpose of Data Base and Data Automation technology is to support the integration of the many stages, subsystems and disciplines of manufacturing into the manufacturing architecture. Although CAM applications may be classified and evaluated in various technology areas, consideration should always be given to their evolution into a common model of manufacturing architecture. Conceptually, this technology area could be visualized to be the glue matrix that holds the Factory of the Future architecture together. Management is often concerned with ultimately establishing a network of subsystems which, when integrated, will provide a total manufacturing information system supportive of planning, production, and control.

RELATIONAL-BASED DATA MANAGEMENT SYSTEM

The engineering community generates data from many varied sources. These sources are characterized by results generated in areas such as testing, designing, and simulating. The data generated also vary greatly in content, controls that are applied to the data, degree of data correctness, and intended use.

Recent advances have shown that relational data base systems, such as the one shown below, are capable of handling the large magnitude of data and number of analyses to be performed in engineering applications. The data base management system (DMS) environment must allow for unpredictable growth, organization, multiple networks of data (data interaction), nonrepeating retrieval criteria, and data that requires caveats to maintain credibility. This environment strongly supports the development of the DMS to be used by the "casual user," thus requiring a high degree of data independence.

A research study was undertaken by the US Army Missile Command (MICOM) to provide a Relational-Data-Model-Based Data Management System which meets the engineering requirements. The system provides a stand-alone, interactive data base management capability to the nonprogrammer which frees him of the requirement to know the data structure. This allows the use of higher level, non-procedural languages through which he may communicate with the data. This also allows basic data storage and implementation changes to be made without impacting the user.

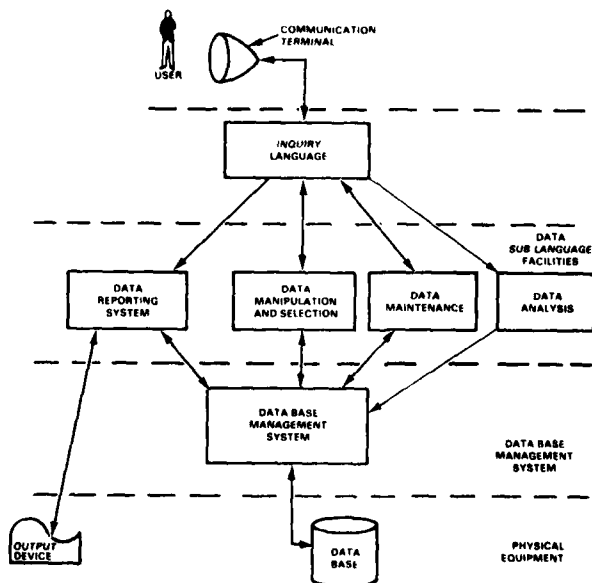

Conceptual View of DMS

The hardware used in the study is as follows:

- a. Minicomputer Interdata 8/32.
- b. 15 CRT Terminals.
- c. 1 - Card Reader.
- d. 1 - 600 LPM Printer.
- e. 1 - 9 Track Tape Drive.
- f. 1 - 7 Track Tape Drive.
- g. 2 - Phone Modem.
- h. 1 - Electro Static Plotter/Printer.

The system software which was available to support the Interdata 8/32 is as follows:

- a. Multi-Task Operating System.
- b. Multi-Terminal-Monitor (MTM).
- c. FORTRAN VI Compiler.
- d. BASIC Level II Compiler.
- e. File Support System.
 - o Indexed Files.
 - o Contiguous Files.

This effort has produced a user-friendly relationally-complete data management system. The system is operational in a multi-terminal, interactive environment provided by the Interdata operating system.

The DMS is a stand-alone system programmed in FORTRAN VI through a structured programming precompiler language called FLEC. It provides data reporting capabilities which allows selective output. In addition, two fundamental data analysis features which allow summing a column of data and performing some basic statistical analyses are provided.

The DMS can support a minimum of 50 data relations per user, with each relation containing between 250-500 columns depending on data types. As it is designed, the number of rows that can be supported is unlimited. The actual number is a function of many variables such as disk size, data types, and other data already on a given disk. The four data types allowable are integers, decimal numbers, single characters, and character strings.

The user is able to interactively create data relations in a real-time environment using the procedure below. While many applications are possible, the system was developed to support the developmental testing community who commonly use operations such as selective retrieval, updating, and inserting of data as tests are being performed. The design allows for changes in the computer hardware support capabilities without affecting the user, maximizing the user's heuristic abilities by providing a group of powerful yet simple tools for his use. More sophistication to reduce the user's load leads to negation of this concept.

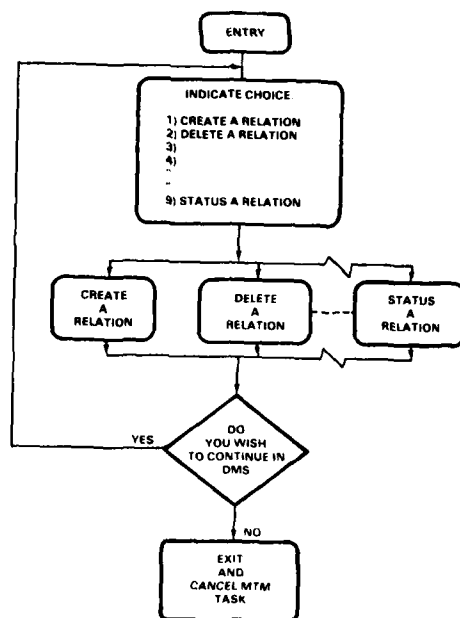

Procedure for Modifying a Data Relation

The use of the system to date indicates the overall objectives of the DMS have been achieved. Although some problems have been uncovered in data storage and maintaining the status indicators of the various relations, the DMS has demonstrated some capabilities that far exceed the initial expectations. The ability of the system to recover from computer system failures has been particularly pleasing. The data retrieval and manipulation features have also proven more versatile and powerful than originally envisioned.

Additional information is available by contacting Maurice Hallum III, MICOM, AUTOVON 746-4141 or Commercial (205) 876-4141.

400 CAD/CAM INTERACTION

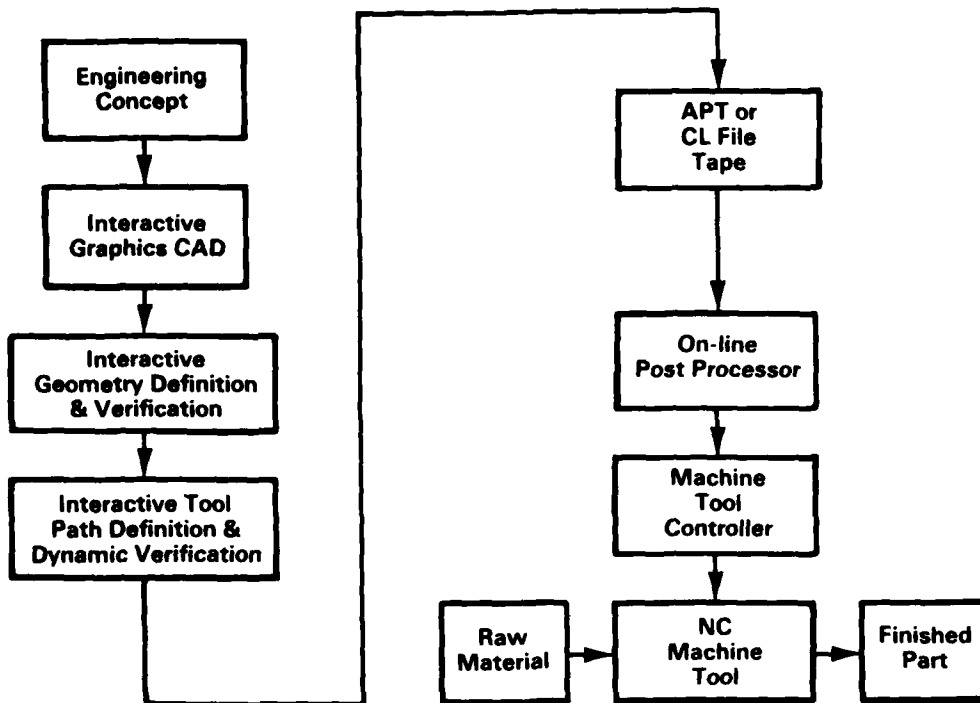

CAD Generation of Machine Tool Instructions

The definition of manufacturing architecture is extended to include the design function, its interaction drivers and computer assisted tools to increase the effectiveness of these interactions. This area focuses on the traditional gap between product design and production engineering by establishing integral bidirectional data paths as bridging so that a product may transition through the gap much more smoothly. Established data requirements and common data bases between design and manufacturing engineering are the usual bridging instruments. Interactive graphics is one of the computer assisted tools which supports a data base for manufacturing.

CAD FOR CASTING

The casting process is an optimum method for producing complex shapes in many alloys such as the one shown below. The process requires lower cost capital equipment and raw materials, offering a wide range of material properties. It has the potential for flexibility of control not found in any other processes. However, the conventional casting process is wasteful in raw materials and energy. About 50 percent more material is melted than is utilized in the final cast configuration. The inefficiency of the process control has resulted in a cost penalty since the scrap and waste must be paid for.

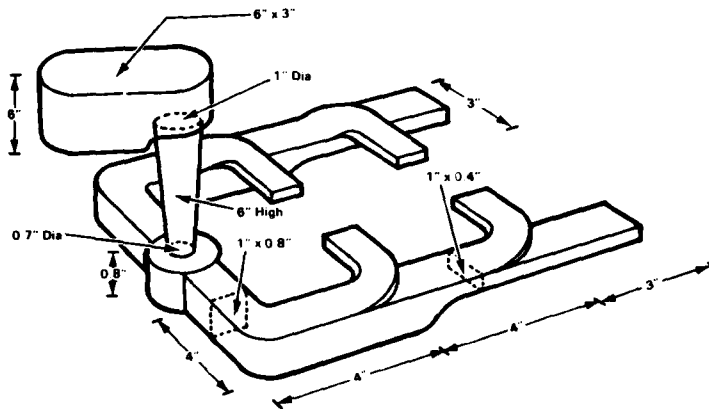

Typical Casting Configuration

Under MMT Effort T-5014, the US Army Tank-Automotive Command (TACOM) contracted the University of Pittsburgh to develop a computer-assisted methodology for designing and analyzing the casting process for the manufacture of high integrity steel castings in sand molds. The overall objective was to replace the art of casting design with the systematic use of scientific principles and the accumulated experience of many designers.

This effort has resulted in a collection of software routines called UPCAST to assist foundrymen in making decisions on the process of manufacturing sound, high integrity sand molds. The design and analysis routines, linked by the overall supervisory program, offer foundrymen the ability to interactively utilize computer graphics and specially tailored analysis packages to design the mold configuration for a steel casting and to analyze the filling and freezing patterns of the casting. Through finite difference and finite element techniques incorporated in the UPCAST software, mold design may be updated based on the results of heat flow and fluid flow simulations.

The UPGCAST software may be said to be driven by a hierarchy of command menus. Once the UPGCAST system is entered, any of the major programs may be called by giving a simple command in response to a query from the program. When a program is entered from UPGCAST, the functions to be performed by routines within the program are specified by typing simple commands from the highest level menu within the program. If further specification of function is required, the user responds to queries from the program by selecting commands from lower level menus. The UPGCAST supervisory routine calls the major programs with the commands: CAD2D, FINGRD, AG3D, BCAST, FITLGS, FEM2D, FDM2D, CSSP1, SOLID. Other UPGCAST commands are HELP and END.

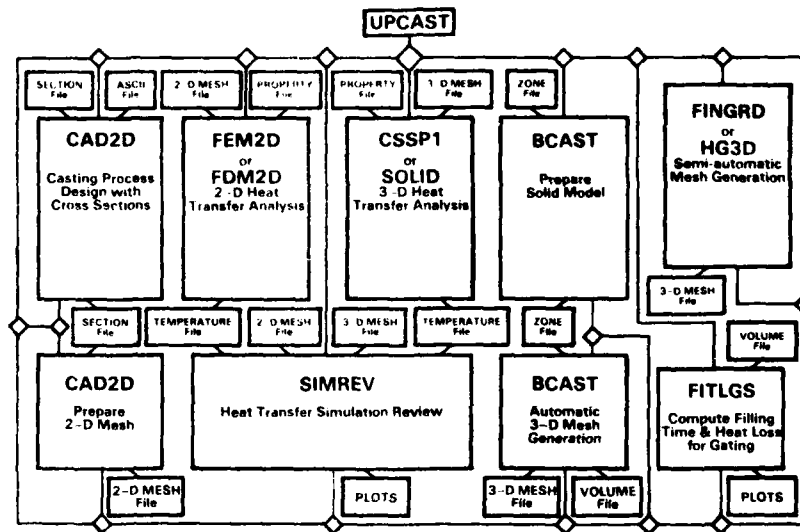

Interface Scheme of UPGCAST Major Programs

Communication of information between different programs is done through the preparation of data files in preset formats as shown above. For example, the outline of the cross section of a casting may be described and entered into memory using CAD2D. The description of the section will be stored in a section file. CAD2D may then be used to create a 2-D finite element mesh of the cross section stored in the section file and the result stored in a 2-D mesh file. Later the mesh file may be used as input to FEM2D for neat transfer analysis. The results can be stored in a temperature file suitable to input along with the mesh file to SIMREV where the analysis of the results of the computations may be done.

The routine and data in UPGAST have been developed for the casting of steel in sand molds; however, the routines are general and may be adapted for other alloys, mold materials, and casting processes. The basis of the simulation routines for computing freezing patterns are applicable to sand casting of any alloy and to any casting process in which the molten alloy is poured into thick insulating molds. Only very general computations and graphical analyses have been incorporated in the design routines. These design procedures are consistent with commonly used methods of riser size and placement determination.

In parallel with the development of the UPGAST software, a verification program was undertaken. Blaw-Knox Foundry and Mill Machinery Co. cast several instrumented test plate castings and over 100 demonstration torsion bar housing castings, of which several were instrumented. All were cast in no-bake sand molds. Lebanon Steel Foundry cast instrumented test plate casting and about 10 demonstration torsion bar housings, two with instrumentation, using green sand molds.

Current production castings will probably not realize benefits from this effort but new casting designs are candidates for implementation of the design procedures. Moreover, because of the resistance to design automation and the low cost of prototype castings, the casting design and analysis software will probably be used on only high cost, large and complex castings.

Upon completion in 4Q 1984, all of the data, results, and software will be available for implementation. Software and procedures will be implemented in two ways:

- a. Battelle, in conjunction with Computer-Vision, presently markets the products, and
- b. The University of Pittsburgh has established a casting technology center as a service to area and regional industry. The center is by membership subscription, and receives subsidized state funding.

Many companies have expressed interest in the results and have conducted parallel efforts. John Deere has selectively incorporated aspects of the technology into their production. Under MMT Effort 6-8231, Rock Island Arsenal is acquiring the UPGAST software and modifying it for the casting of iron, copper alloys, aluminum alloys and steel alloys. Additional verification castings will be made for these other metals.

Additional information is available by contacting Mr. Ed Borto, TACOM, AUTOVON 786-8711 or Commercial (313) 574-8711.

SACRAMENTO ARMY DEPOT CAD/CAM

The principal operation at the Sacramento Army Depot (SAAD) Directorate for Maintenance concerns the design, modification, and fabrication of communications vans and trailers. These structures house a wide range of sophisticated military equipment and serve as radio and telephone centers, repair shops, and storage units in tactical locations. The mechanical design and drafting are complicated processes demanding months of intensive labor. The manual methods were effective for minor design alterations; however, there were many dimensioning problems on large projects which warranted as many as 20 drawings to describe a complete internal modification. Tolerance overruns in mounting bracket fabrication were not uncommon, and drilled hole alignments in brackets and structural members were up to an inch off in some instances.

Under Modernization Effort GS02, SAAD contracted Gerber Systems Technology (GST) Inc. for the purchase, installation, and checkout of their CAD/CAM system. With this system, SAAD engineers, designers, and draftpersons can interactively create three-dimensional, geometric models of intricate parts and assemblies on the high-resolution, color workstation screen as shown below. These precisely calculated graphics models can be viewed in any orientation, fully dimensioned, stored in the system's data base, and recalled to output comprehensive engineering drawings or to generate tool path data for machining.

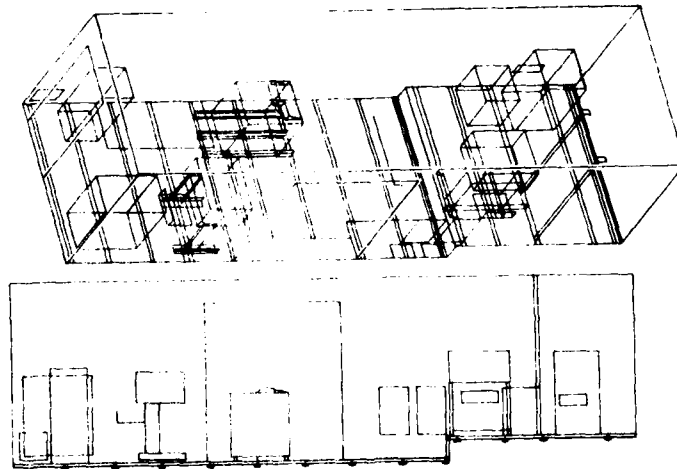

CAD Display of Shelter

SAAD received their first ten Autograph systems and one Shared Resource Manager (SRM) in July 1983. A sophisticated CAD facility was built within the PD&D building. This environmentally controlled room currently houses six Autographs and peripherals as well as the SRM and two pen plotters. The remaining four Autographs are located in the Engineering Branch, approximately 1500 feet away in another building and linked to the SRM via a remote network. Three of these systems are used for facilities modernization planning, mold design, fixturing, and special printed circuit board (PCB) work. The fourth system is located in the Manufacturing Engineering Technology Section to support the N/C department.

The SRM combines hardware and software into an intelligent, independent network node consisting of a CPU with 1M byte of memory, a 300M byte disk drive, an 800/1600 switchable magnetic tape unit, a reliable edit terminal, and GST's unique Data Management System.

Along with the 10 standard Autograph hardware packages, SAAD selected GST's color graphic workstations. With 256 design levels and comprehensive color-coding capabilities, the workstation screen permits a clear display of dense graphic data. For expansion and flexibility, the SAAD also purchased 10 hard copy graphics printers, 3 portable and adjustable data entry tablets, a paper tape reader/punch for N/C applications, and 2 industry-standard, E-size drafting plotters.

Using the Mechanical Design and Drafting software, the designer interactively constructs the entire shelter one part at a time on selected design levels. Every component is included in this data base model including color-coding specifications. For designing both the mounting brackets and the metal boxes that house the electronics, the Sheet-Metal Development (SMD) software is employed. This provides functions which automate the unfolding of 3D sheet-metal models into flat pattern layouts. It facilitates the design and fabrication of singly curved sheet-metal parts consisting of straight section, straight flanges, and singly curved smooth contours.

PD&D is also involved in PCB design for electrical assemblies used in instrumentation from air traffic control units to automatic fire detection devices. The Auto-Path software is an automatic placement and multi-layer routing program. This software graphically builds a board from a completed schematic diagram. A 5:1 improvement over manual design procedure has been realized to date.

SAAD has many CAM projects in planning. CAD will be introduced into the sheet-metal operations by integrating CAD/CAM with punch presses for shelter skin and mounting bracket fabrication. The CAM facilities will be expanded by the acquisition of more lathes and machining centers. Productivity increases have already been realized in both 2-1/2 axis milling and lathe machining.

In the first 12 months of CAD/CAM system utilization, a 30 percent savings in engineering design time, up to 200 percent increase in drawing output, and increased shop production have been realized which support a 2-year payback schedule.

Additional information is available by contacting Mr. Duane George, SAAD, AUTOVON 839-2398 or Commercial (916) 388-2398.

TOBYHANNA ARMY DEPOT CAD

The Production Engineering Division's capabilities at Tobyhanna Army Depot (TOAD) have been greatly enhanced by the addition of an interactive graphics CAD/CAM system with Asset Capitalization Program Effort GT102. This system aids in creating, changing, dimensioning, and manipulating CAD drawings like the one below. Following a 3-year leasing period, the system was purchased from Applicon in April 1984.

The system is located in an environmentally controlled room adjacent to the drafting operation, and is controlled by a PDP 11/34 Central Processing Unit (CPU). The data base is on a 200 million byte disc pack and on a magnetic tape drive. There are four graphic work stations tied to the CPU, three of them black and white and one color. Attached to the terminals are a keyboard, menu pad for macro commands, and an electronic stylus which is similar to a draftsman's pencil. This gives the operator several methods of inputting information to make a drawing. One of these work stations has a digitizer which is used to input existing drawings into the computer. Three plotters provide the output of this system. They are hard copy units which give the operator a quick and rough copy of what is on his screen, an electrostatic plotter which gives a 24" wide quick check print, and a large flatbed plotter to produce a high quality finished drawing.

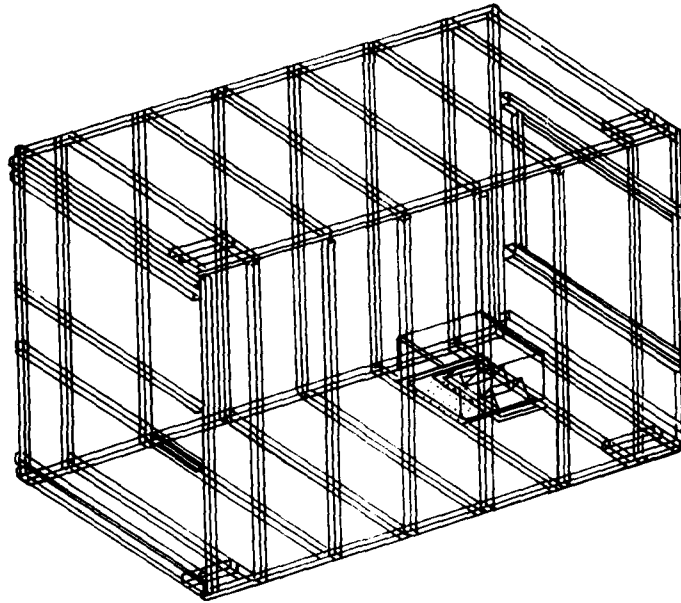

Typical CAD Drawing

The system's drafting capability includes creating, changing, dimensioning, or manipulating a drawing and displaying it in any view. Whatever the draftsman could do on a drawing board can be done with this

system, only easier and faster. With the printed circuit board design software, components can be picked and placed on a board, automatically routed the circuit paths, circuits checked against schematics, and a net listing printed. It can also be used to design schematics, equipment nameplates, and show cable runs. With mechanical or 3-D design, an engineer can place an entire shelter or van configuration in the system; then design the racks, place components or equipment in the racks, check tolerances and cable runs. Jigs and fixtures can be designed and the item placed into the fixture and tolerances checked before the fixture is even built. Inspection includes such things as checking tolerances and fit. Such tool design is expeditious in the performance of the depot's activity.

For demonstrating the 256 layer architectural lay-out capability, an extensive surveying project was conducted to determine the square footage of all shops in the Maintenance Directorate, as well as the exact location of all benches and equipment in the shops. Once the depot and shop layouts are placed in the computer, the materiel and workload flow can be manipulated for optimum performance.

Once a drawing and pertinent information are in the computer, the system will automatically generate data including engineering analysis, bill of material, and NC tape for that drawing. The engineering analysis software calculates such things as weight, volume, center of gravity, and if necessary, stress and strain analysis. A bill of material listing all of the components or material required to produce an item will be generated, and by selecting the machine, types of tools, and cutter path, an NC tape will be produced.

A CAD/CAM expansion planned for FY 85 will provide increased capacity and capabilities necessary to fulfill mission requirements, reduce backlogs, improve productivity, and enhance the design and engineering support functions. The following equipment will be linked with the existing CAD/CAM system: 1 VAX 11/751 CPU with Applicon disc drive, 1 tape drive, 1 alphanumeric terminal, 2 black and white terminals, 4 function keyboards, 1 hardcopy unit, 1 24" plotter, and various application software packages. Plans beyond the initial expansion include CRT displays in the shops, Quality Assurance, and Engineering, which will be used to transfer information between these areas and drafting. A direct link to the CNC machines will also be established, eliminating the need for paper tapes.

The future plan envisions the Applicon System as the controller of a large integrated system. Once the total system is in place, an engineer can design a part, analyze it for such things as stress and strain, have it finalized by drafting, prepare an NC program, and send it directly to a CNC machine for fabrication. Other capabilities will include merging text and graphics for technical manuals, automatic visual inspection or testing with ATE, programming robots, or a link-up to other computers such as the Standard Depot System computer to order material through the automatic bill of material, generate procurement packages, or transmit drawings.

Additional information is available by contacting Mr. Frank Estock, TOAD, AUTOVON 795-7099 or Commercial (717) 894-7099.

POWDER METALLURGY PREFORM CAD

Powder forging is a process in which preforms made by press and sinter powder metallurgy (P/M) techniques are hot forged in closed impression dies. Powder preform forging successfully combines the advantages of conventional P/M with forging property enhancement. P/M preform design was time consuming and error prone because it was empirical. Rational powder preform design requires knowledge of a plethora of parameters to be controlled. The high cost and long lead time of manual design procedures has been a significant motivation for the development of a CAD approach.

Under MMT Effort 6-7649, Rock Island Arsenal (RIA) contracted the University of Pittsburgh to develop an interactive CAD approach for P/M forging preform design and to apply it to the design of the M85 machine gun cartridge guide ramp. The resulting CAD approach consists of two major activities, Part Geometry Description and Preform Design. The part geometry description program was developed to describe a 3-dimensional part in a form that is suitable for subsequent processing by the preform design phase. The preform design phase is in an interactive graphics environment to allow for a rapid evaluation of trial preforms.

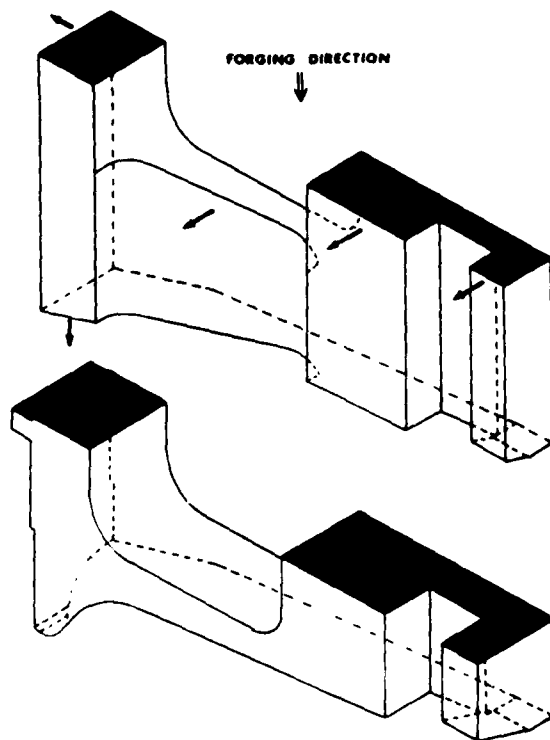

CAD Preform and Final Forging

The sub-division of a complex part into regions may be accomplished either by the designer explicitly specifying the regions or the program determining the region sub-divisions automatically according to a predetermined set of rules. The regions are explicitly specified, during part description, according to rigid guidelines to prevent possible design failures at a later stage.

The software program that was developed is called "PADEL" (Part Description Language). It is tailored to specifically meet the requirements of powder forging. In addition to being able to describe the part, region sub-divisions may be readily accomplished, forging directions specified, and volumes calculated which are features peculiar to powder forging. It is not generalized to describe all possible components. Nevertheless, it is capable of describing a large class of parts that are currently being powder forged. PADEL was written for the most part in Fortran 10, except for some routines which were written in assembly language. The current version of this software is operational on a Digital Equipment Corporation PDP-10. Computer graphics capability is provided using Tektronix Plot-10 software.

In the interactive preform design phase, the preform shape is arbitrarily specified for each region by the designer. Depending upon the specification, the generic modes are isolated and the specified shape is evaluated for consistency, densification, fracture, etc. by the program. The preform profile is then interactively manipulated by the designer until a satisfactory preform is determined. Some experience is required to judge whether the preform is satisfactory from a practical standpoint. Additional decision making functions can be built in as further knowledge and experience is obtained in preform design.

The Cartridge Guide Ramp of the M85 Machine Gun was selected for demonstration purposes because of its relative complex configuration and non-axisymmetric shape. After the design was complete, six preforms were machined according to the preform drawing. The material was 4640 steel powder, compacted to 80 percent density and sintered at 2050F. Each machined preform was coated with graphite, reheated to 1800F and forged in a hydraulic press. Prior to forging, graphite in water was sprayed on the dies for lubrication. The forging trials were successful with no defects in the forgings. The lugs, lip, etc. were fully formed. Macrographs taken at various sections indicated good densification, except for some residual porosity at the surfaces.

The PADEL software established by this effort was used by TRW, Inc. to design preforms for tank gears under TACOM MMT Project 4 7X 5083. Borg Warner is also using modules of the software. Hoeganaes Corp. has recently invested \$1 million in a CAD system, a 700 ton press, and a reheat furnace. Their simulation software is based on the PADEL.

Additional information is available by contacting Mr. M. Solanki, RIA, AUTOVON 793-6198 or Commercial (309) 794-6198.

500 PLANNING AND GROUP TECHNOLOGY

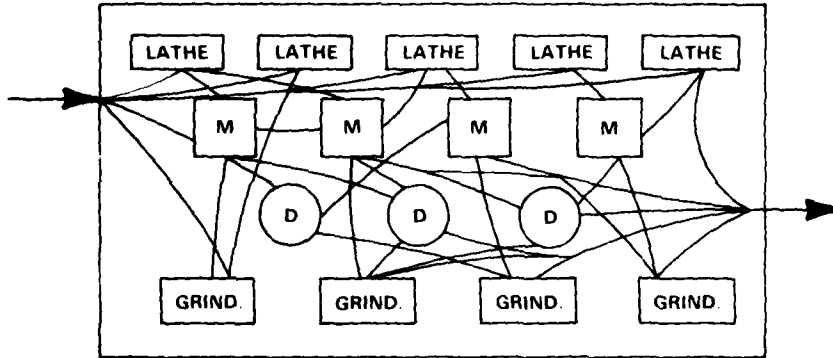

Typical Process Flow

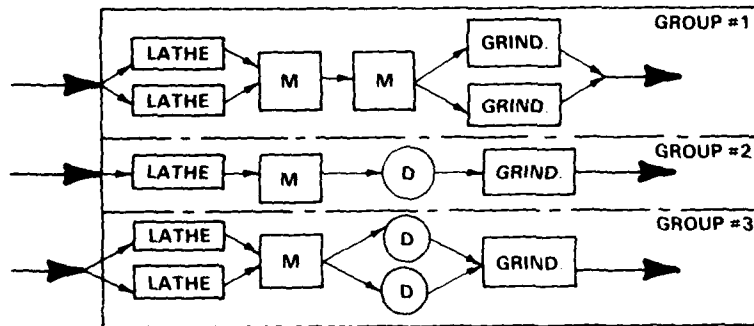

Group Technology Process Flow

This area encompasses efforts directed at optimizing process planning, production scheduling and control, factory layout, and other tasks that have a significant impact on manufacturing cost and which are normally performed by indirect personnel. These tasks are intended to develop software systems that promote using the physical characteristics of a component to minimize its own production schedule and to ease its fabrication planning cycles.

GROUP TECHNOLOGY FOR AMCCOM

A major area of concern in industry today is production scheduling of job shop operations. Most scheduling efforts for large limited product line companies are centralized in a production control department. However, when the typical job shop situation is observed, part routings result in a maze of parts traffic throughout the shop. Unique problems such as job priorities, machine breakdowns, absenteeism, and misplaced parts cause job sequencing to be performed by the foreman on the shop floor. Because of the many combinations of possibilities for scheduling, the foreman has a difficult time selecting the optimal job sequence.

Production scheduling can be greatly simplified by Group Technology (GT). GT is a manufacturing philosophy that identifies and exploits the underlying sameness of parts and manufacturing processes yielding significant benefits as shown below. GT is currently being used as an aid from the design process through facilities planning. GT reduces the scope of the scheduling problem from the full shop to smaller groups of machines. Algorithms developed specifically for sequencing jobs using GT concepts are categorized as Group Scheduling. Proper applications can result in a reduction of set-up time and cost, optimal group sequence and job sequence, optimal machine loading for more effective machine utilization and reduced inventories.

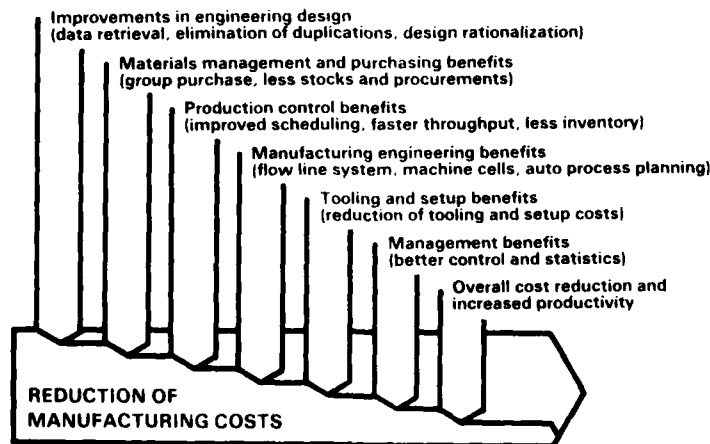

Benefits of Group Technology

Under MMT Effort 6-7963, the US Army Munitions and Chemical Command (AMCCOM) contracted the Organization for Industrial Research, Inc. (OIR) to establish a pilot GT system for fire control machined parts. The long term goal in mind was to establish a standard common coding and classification (C/C) system throughout all Army installations. The major thrust of this effort consisted of the installation of MICLASS C/C & MIGROUP Software, MICLASS, MIGROUP, and MIPLAN Training; and coding/data storage for 3300 part drawings in a common data base. A prior MMT project established the basic group technology requirements for fire control parts and assemblies.

MICLASS version 2.0 software was installed on the AMCCOM CDC 6500/6600 computers. This is an updated, improved MICLASS software package that is both easier and more efficient to use than the version purchased with the prior effort. The flexible record layout of the version 2.0 software includes actual machine tool time in a real value and the capability to handle unusual character lengths for drawing numbers. Retrieval possibilities and speed, and matrix analysis capabilities have been expanded. The input/output requirements for each program have been changed for better user understanding, and have been human engineered to require little or no computer knowledge.

MIPLAN is a production oriented computer assisted process planning system. It's modular construction makes it possible for the process planner to generate process plans in any of three ways: Construct a new process plan from standard texts for each operation; retrieve a previously used process plan from the files by a part number or other descriptor; or use partial or complete GT code numbers to retrieve plans for the same or similar parts. Any plan retrieved from the file can be edited to meet the specific needs of the part being manufactured.

The MIGROUP Software is a software program for analyzing and processing MICLASS files. The software provides for production flow analysis based on current routing information relationships and provides code number analysis based on relating part characteristics to machining requirements.

A code number analysis was performed to find preliminary families of similar AMCCOM parts by relating part characteristics to machining requirements. The analysis of the first four digits produced 665 distinct configurations. These 665 configurations separate into 20 identical part shapes each. Five of these groups have populations with more than 100 parts with another five groups totalling between 50 and 100 parts.

Updating of MICLASS System is being pursued due to its limitations of providing for machined parts and sheet metal parts. Discussion with OIR has provided additional information their new MULTICLASS System and its application to existing systems. MULTICLASS is a comprehensive system which utilizes consistent C/C software to accommodate the full range of the components of manufacturing system (electronics, optics, assemblies, tooling, etc.). MULTICLASS is a complete system ready for implementation in the working environment, although some customizing may be required.

AMCCOM contracted Pennsylvania State University to develop algorithms for group scheduling. The Group Technology Scheduling Software developed by Penn State University was installed and debugged on the AMCCOM CDC computer. Initially, parts are formed into families according to the GT concept. If parallel sequencing transfer of jobs is selected, the machines must also be grouped into cells. Each lot of parts is viewed as a job with a specific sequence of operation (stages/machines) required for the unidirectional and non-unidirectional problem with either successive or parallel sequencing transfer. Alternately, the software is capable of determining the schedule for minimum tardiness. This method takes due dates into account for each job, but only considers successive sequencing transfer. This software is currently being evaluated.

Upon completion of this effort in 4th Quarter 1984, the group technology system and software will be transferred to candidate USA depots and interfaced with MMT Effort 6-8327 titled "CIM for Fire Control Material."

Additional information is available by contacting Mr. Nathaniel Scott, ARDC, AUTOVON 880-6945 or Commercial (201) 724-6945.

GROUP TECHNOLOGY FOR WATERVLIIET ARSENAL

Watervliet Arsenal (WVA) has embarked on an aggressive plan to implement CAD/CAM technology in its REARM (Renovation of Armament Manufacturing) program. This gives the opportunity to rectify the prior inefficient manufacturing practices. The objective of MMT Effort 6-7724 was to reduce manufacturing costs and improve throughput time via the application of CC/GT at WVA. This is part of the AMCCOM long term goal of establishing a standard CC/GT system throughout the Army. The Organization for Industrial Research (OIR) was contracted to code, classify and analyze a grouping of parts for the identification of part-families, a manufacturing cell or cells, and make/buy parts. OIR created a Machine Tool File (MTF), a Material File, and a Parts File to perform a comparative analysis.

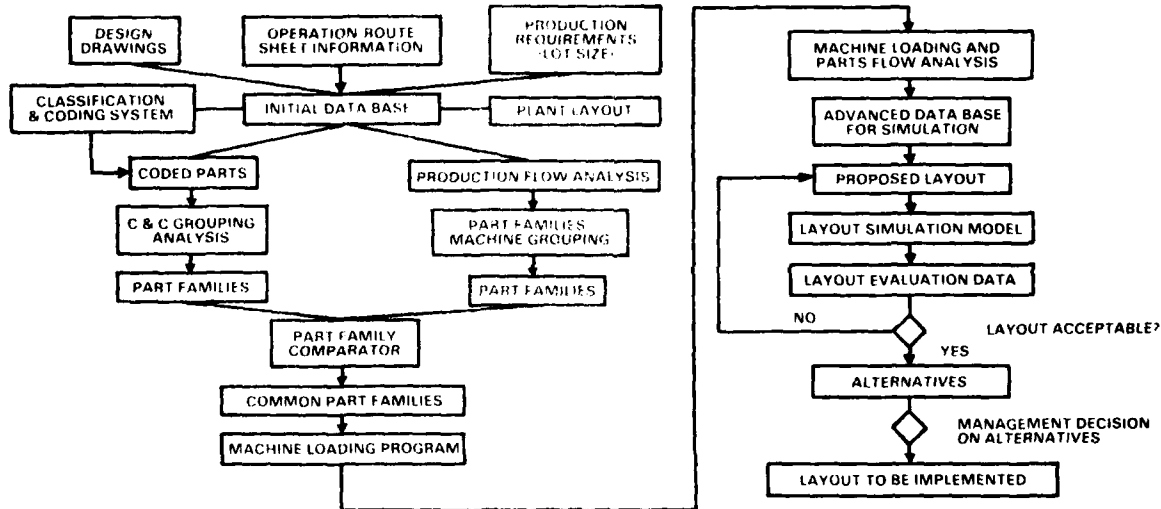

Group Technology Process and Equipment Planning Flow

The MTF file is a binary file used by the previously purchased CC/GT software, MICLASS, to determine individual machine costs and loadings. The MTF includes information for machine codes, machine tool name, the number of machines in the category, and the total available hours within the release period.

The Material File consists of material names and a code number. The material name specifies both the composition and the general shape of the raw material. An established index of values by WVA, comprising 120 different material categories, was coded by the MICLASS System and entered into a binary datafile.

The Parts File was split into a file consisting of parts that were never purchased, and another file containing purchased parts that may have been manufactured in-house. Included in both files were the MICLASS code number, part drawing number, part nomenclature, year of manufacture or purchase, quantity manufactured or purchased, along with set-up time, piece rate, machine code, and department numbers.

The MICLASS code number consisted of 18 digits. The first 12 digits were in reference to the geometry of the parts; i.e., form, dimensions, tolerances, and materials. The remaining six digits depicted annual lot sizes and releases, additional dimensional information, and manufacturing operation codes.

OIR employed the MICLASS code number to find families of similar parts. Since the basic design of the MICLASS coding system relates part characteristics to machining requirements, this technique can also be applied to find manufacturing families. A net total of 474 rotational parts were coded, classified, and analyzed. Eight different part families were identified which comprised 171 parts total. Along with each part family was the identification of a potential manufacturing cell.

A scheduling system to support manufacturing was developed by Prof. Inyong Ham of Pennsylvania State University. Scheduling algorithms using GT concepts were developed independently from this project. The two most significant algorithms are the "Ham-Petrov" near optimal scheduling algorithm and the "Cho-Enscore-Ham" due date constraint, multi-stage, scheduling algorithm. Both of these algorithms are heuristic procedures which produce a schedule that closely parallels an optimal schedule for least makespan time of manufacturing M parts using N machines. The algorithm was programmed in BASIC for use on a microcomputer. The programs have been enhanced, converted into FORTRAN 77, and successfully demonstrated. Testing and evaluation are ongoing to determine their usefulness.

IBM and Tektronics microcomputer hardware has been purchased and installed to support solid modeling. WVA personnel have been trained in the operation of the hardware. Acceptance of the system and integration are ongoing with completion expected in September 1985.

Additional information is available by contacting MAJ Walter Olson, WVA, AUTOVON 974-5827 or Commercial (518) 266-5827.

GROUP TECHNOLOGY FOR ROCK ISLAND ARSENAL

Rock Island Arsenal (RIA) has been producing gun mounts, recoil mechanisms, artillery, gun carriages and machine guns for many years using equipment which is rapidly being antiquated and which is widely disbursed in the facilities. RIA is currently executing a modernization program Renovation of Armament Manufacturing (REARM). This offers the opportunity to improve on all currently used production methodologies.

Current developments in the areas of classification and coding (C/C) systems and group technology (GT) as applied to discrete parts manufacturing indicate substantial savings can be achieved to bring many of the benefits of mass production to small lot production. The objective of MMT Effort 6-7949 is to incorporate GT to reduce manufacturing costs and lead times in the REARM program. By classifying and coding production parts utilizing the commercially available MICLASS software, the inherent similarities of parts can be taken advantage of to improve manufacturing processes and control. This effort is similar to MMT Effort 6-7963 for AMCCOM and MMT Effort 6-7724 for Watervliet Arsenal.

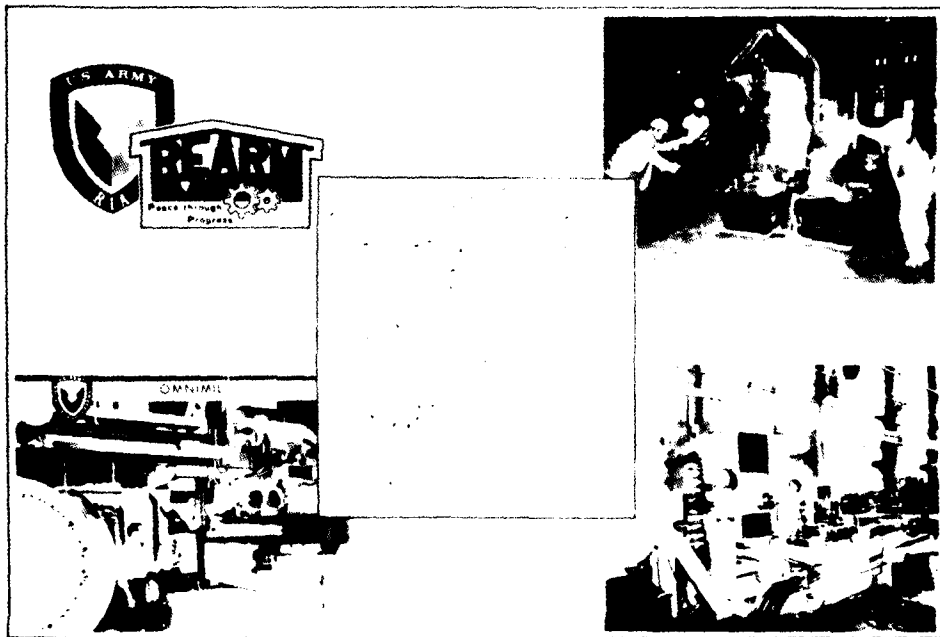

The MICLASS software has been installed on the in-house PRIME computer system. The MICLASS software uses an interactive program to assign code numbers to parts. The code number identifies the part shape, size, machining tolerance, etc. These code numbers then provide the basis for analysis via the group technology programs.

The Organization for Industrial Research was contracted to identify part families for RIA's machined parts and submitted its report identifying part families and analyzing in detail three of the identified part families. A total of 3288 production parts were coded with the first 18 digits of the MICLASS code number (MICLASS I and II). Additionally, 1484 parts were coded with an extension to code number (digits 19-30, MICLASS III). These coded parts, combined with MICLASS software, training, and part process routings, form the basis for part family and machine layout analyses. The percentage of parts coded represents 76 percent of the parts for RIA's major production items.

A plant layout was developed using MICLASS for consideration in RIA's REARM modernization. A machining department organization was developed, consisting of five departments which maintain 97 percent of the part moves within the same department. The comparable figure for the existing organization is 82 percent. Making each of the five major machining departments responsible for almost all machining on their assigned parts will provide the following benefits:

- (a) Reduced part movement.
- (b) The capability to standardize process plans for groups of similar parts (part families), to group the machines required to manufacture each part family into machine cells, and to reduce the total setup time by scheduling, in sequence, parts requiring similar setups.
- (c) Easier control of production resulting from fewer departments involved in the machining of any one part.

Extensions to the MICLASS were developed to assist in developing and analyzing various layouts. The GT data base and software was utilized to assist in flexible machining system, mobilization, and machine replacement analyses. The requirement for a parts classification system was identified to support a future computer assisted process planning (CAPP) system. Implementation of an automated process planning system will be carried out under MMT Effort 6-8306, On-Line Production Information System.

Actual plant rearrangement into GT organized machining departments will be part of RIA's Project REARM. The major part of Project REARM will be performed during FY 83 through FY 87.

Additional information is available by contacting Mr. John Wilkins, Rock Island Arsenal, AUTOVON 793-5897 or Commercial (309) 794-5897.

COMPUTERIZED PRODUCTION PROCESS PLANNING

Early in product engineering and development, process planning is responsible for determining the general methods of production. In the last stages of design, part design data is transferred from engineering to manufacturing and process planners develop the detailed work package for fabricating the part. Computerized Production Process Planning (CPPP) is the activity of using a computer program to describe how to manufacture a product. It gives an opportunity for the planner to identify the best set of parts and operations in the most advantageous sequence and time required to derive the optimum process plan for a given product.

The two broad areas of process planning are overall part planning and operational detail planning. The overall part planning includes activities that involve the entire part such as developing the sequence of operation, selecting the correct machine tools, and selecting the work-piece blank. The operational detail planning covers such areas as the NC programming, selecting the cut pattern, and selecting tooling and fixtures.

MMT Effort R-1021 for the development of computerized process planning technology was initiated by the US Army Missile Command (MICOM) with several criteria in mind. First, the CPPP system must be adaptable to any manufacturer of mechanical parts. Secondly, a CPPP system should be capable of generating alternative solutions to a process problem and then pick the best. Thirdly, full part design information should be available to the system. Finally, a man/machine interaction capability is needed for situations where manufacturing would want to change computer decisions.

The CPPP system developed by United Technologies is an integrated system of seven principal software modules as follows:

- o The Data Input System
- o The Language Processor System
- o The Data Base
- o The Process Decision and Analysis System
- o The Vocabulary and Cut Application System
- o The Interactive Display System
- o The Process Plan Output System

The data input and language processor systems provide a manufacturer with the means to build the large data base that is required for process planning. The data base contains descriptions of the workshop's machine and tool resources, stock removal allowances for cutting materials, cutting tolerances, machineability information, process decision models, and the part design.

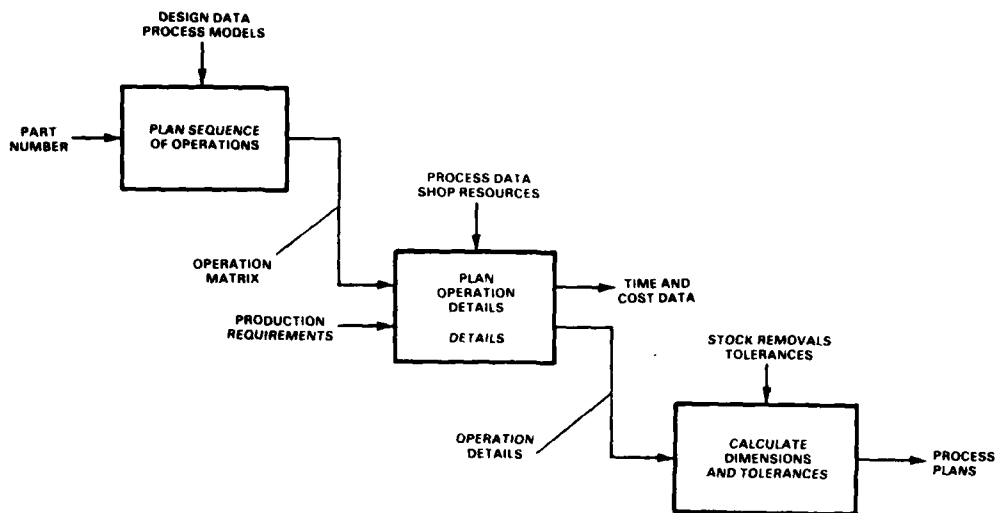

Process Planning Flow

Three primary process planning functions of CPPP are organized to produce a process plan in distinct and separate steps as shown above. The first step generates the sequence of operations. It begins when the process planner inputs a part number to retrieve the design data from the data base. The raw material description and a classification code retrieved identifying the part family are used to retrieve the appropriate process model from the data base. The sequence of operations is generated with the process model alone or by a combination of the model and process planner interacting with the system. The model is programmed to determine a sequence of operations based on specific geometry and material characteristics found in the part design data.

The second planning function generates the details of each operation. An analysis procedure was developed to evaluate alternative combinations of machine tools, cut sequences, and cutter tools for each operation. The best combination is based on optimum production rate or cost performance. As in the first planning function, the process planner has the option to interact with CPPP to review or modify decisions made.

The third planning function calculates the actual workpiece dimensions and tolerances for each operation. This function serves to ensure the part can be made within tolerance by the process plan. A salient characteristic of this function is the use of tolerance chart procedures for analyzing tolerance buildup and calculating dimensions. The output produced is used to generate operation sheets with dimensioned workpiece sketches.

The CPPP system has been partially implemented at three divisions within United Technologies Corporation; Pratt-Whitney, Sikorsky Aircraft, and Hamilton Standard. The system has also been applied on two military aircraft engines and on components used on the Blackhawk helicopter, Navy lamp helicopter, CH53E helicopter, and F-16 and A-10 aircraft.

Additional information can be obtained from Mr. Bobby Austin, US Army Missile Command, AUTOVON 746-2147 or Commercial (205) 876-2147.

600 MANUFACTURING CONTROL

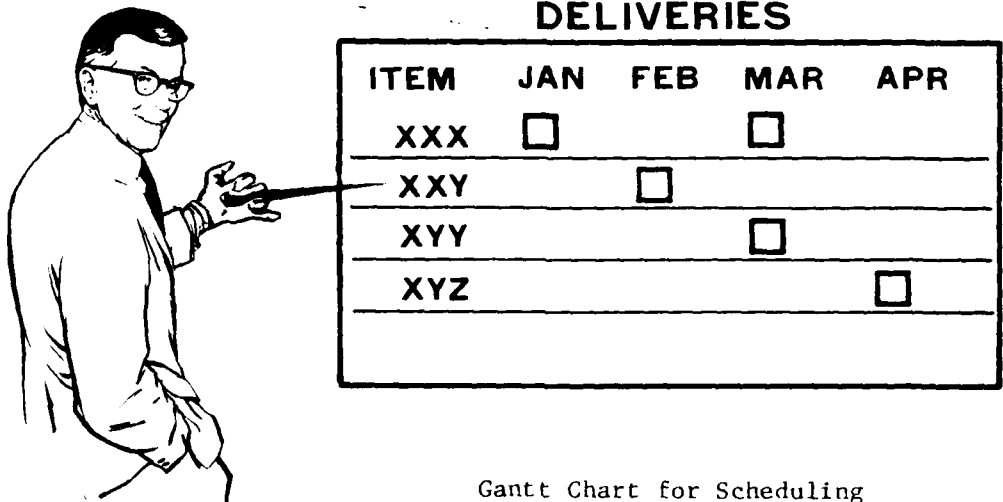

The generic technology for producing management oriented information tools for scheduling, monitoring, and controlling operations within the manufacturing environment resides at a high level in the Factory of the Future architecture. It is closely related to the technology areas of Fabrication, and Planning and Group Technology. Production manufacturing control activities historically bear the major burden for exercising the coordination of production facilities to produce products on schedule at optimum cost. Manual systems of scheduling, monitoring and controlling processes are not sufficiently responsive to a constantly changing workload environment to permit optimization of high productivity and economics offered by modern manufacturing methods and equipment.

MAINTENANCE SHOP FLOOR SYSTEM

The shop floor control and data reporting systems at Army depots have needed updating for many years. In the manual control system, data records for the functional reporting areas were physically transported from the shop floor to the management record keeping. Because of the delays in data reporting and compilation of the shop status, scheduling and control were difficult and inaccurate. With increasing workloads, the system deteriorated further.

In order to improve the management of the depot maintenance activities, the US Army Depot Systems Command (DESCOM) initiated the Standard Maintenance Shop Floor System (MSFS) Program with Asset Capitalization Program funding. The objective was to design, develop, and implement a system providing overall material in-process control and visibility to support the work processes on the shop floor of each of the depot's maintenance activities.

The MSFS consists of integrated computer hardware and software which improve procedures, receipt control, and information accessibility, by allowing real-time access to the data base. This reduces operational complexities, manpower effort, and costs. The hardware used to access MSFS will also be used to access the Automated Labor and Production Scheduling (ALPS) System when it goes on line.

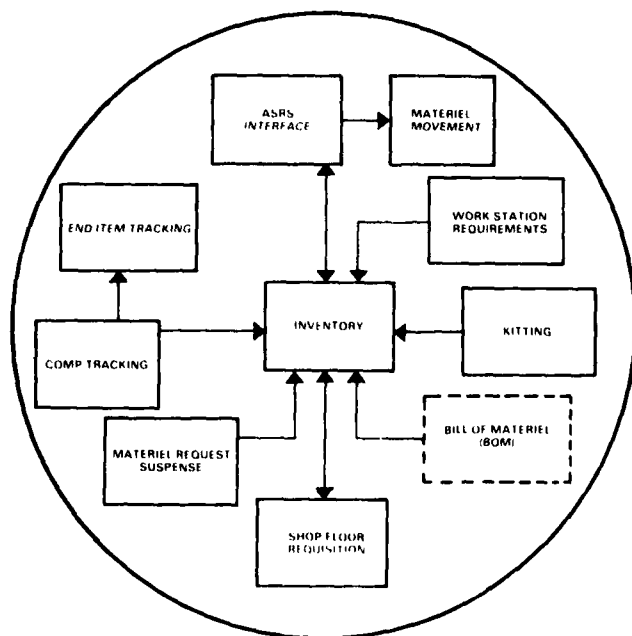

MSFS Modules

The system shown in the illustration consists of seven independent interfaceable modules and an optional ASRS interface. The Inventory Module is the hub of the system. Interfacing the inventory module are: Work Station Requirements Module, Kitting Module, Requisition Module, Maintenance Materiel Request Suspense Module, Component Tracking Module, and the End Item Tracking Module. A Bill of Materials Module will be developed to further enhance the MSFS capabilities.

The Inventory Module is the hub of the Maintenance Shop Floor System. It can be used by itself with the data base being built entirely by manual input, or can be used in conjunction with other modules. It is the source of asset information for any requirements versus assets comparison. In addition, it provides a baseline from which to begin transferring assets upon closeout of one program and the cross-reference for catalog update and file maintenance access to the data base.

The Work Station Requirements Module provides repair parts and component item data and visibility necessary to permit any one work station to know what its overall materiel support requirements are for any one job or for all jobs collectively. A primary feature of this module is the capability of simulation to project parts shortages and pre-assembly of a work station repair parts based on the current work station production schedule. The preassembly of work station parts at a central parts staging area reduces the requirements for floor stock and provides visibility of all assets regardless of the source of supply.

The Kitting Module provides the ability to maintain a list of items that can be pre-assembled in a fixed quantity for common use. Kits can be assembled at any time and sorted as a single line item, either complete and incomplete. Records of each item missing from the incomplete kits are kept. Thus, the module reflects kitting requirements as well as kitting status.

The Requisitioning Module gives the capability to order repair parts from the shop floor. When used in conjunction with kitting and work station requirements, this module provides the capability to produce individual or multiple line-item transactions with minimal user input. In addition, when used with the Inventory Module, a real-time update is provided for current due-in quantities for requisitioned repair parts.

The Maintenance Materiel Request Suspense Module automates the process of maintaining status on all open requests for parts, including the delivery status by the storage activity, and actual receipt of material by the maintenance activity. Initial suspense data set is built by copying requests for issue. Updating consists of shipment confirmation action from the storage issues application, exception status from the installation supply application, and notice of receipt of materiel from the maintenance activity.

The Component Tracking Module provides the ability to track components of end items through various shops until the rebuilt item is placed in inventory or delivered to final assembly. The component track is automatically related back to the end item to identify possible constraints to the end item schedule.

Because of the high volume of components to be tracked, and the number of work stations reporting, LOGMARS bar coding is used. A bar code number is assigned and printed on the move ticket. As the component moves from workstation to workstation, a read of the bar code will create an update action against the data base. The bar code number becomes a cross-reference to the key data elements used for updating the master data base.

The End Item Tracing Module provides the Maintenance Directorates the capability to develop a pre-defined process route of selected work areas. By having this process route defined, the user has the capability to track the end item from induction to completion. The pre-defined route can identify selected work areas from the overall repair process route as critical checkpoints in the route. Comparison of projected cycle times against actual process times provides the capability to predict when the repairable end item will be completed.

The MSFS is being implemented at Tobyhanna Army Depot under Project 84-031 with a scheduled completion of February 1985. Five additional

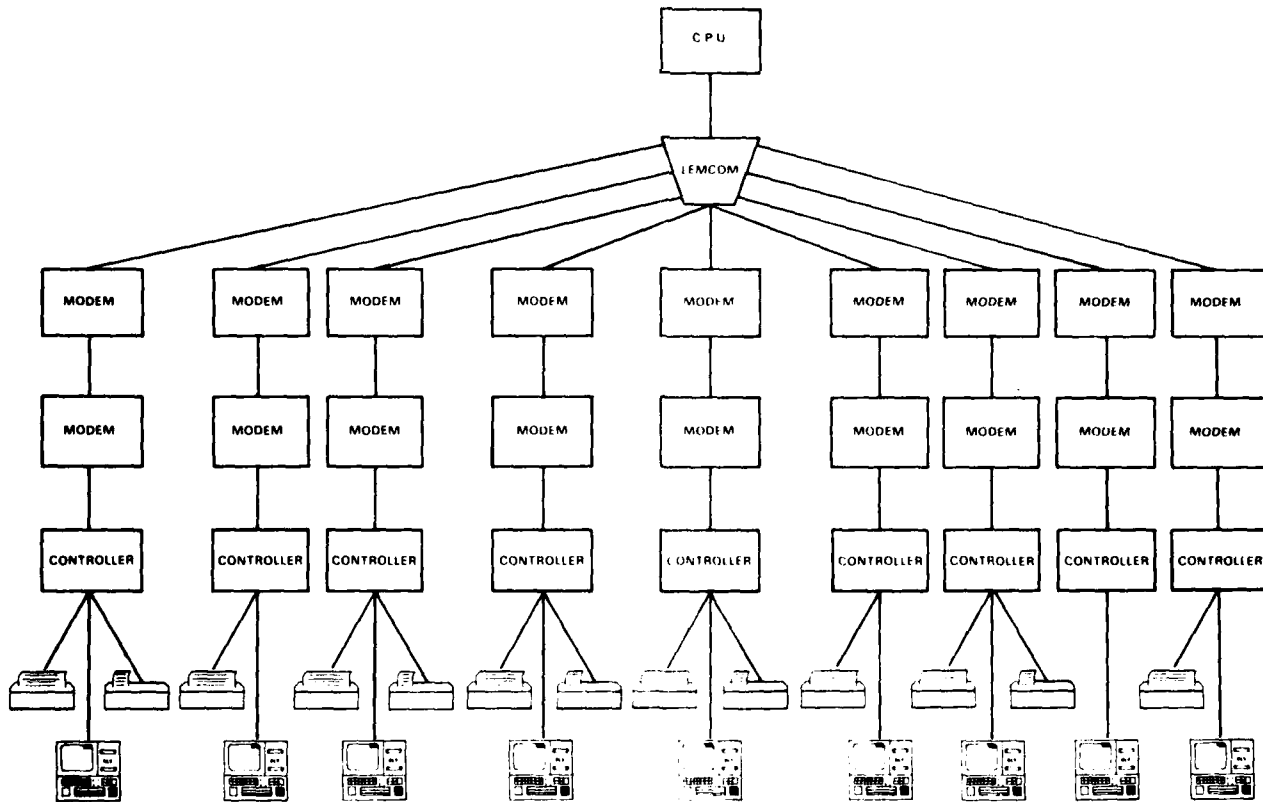

Corpus Christi Inventory Module Implementation

depots with maintenance support missions are scheduled to receive the MSFS. Tobyhanna is the first depot to test the MSFS-ASRS Plus Interface using a Local Area Network (LAN) for system interconnection. (ASRS Plus is covered in the Material Handling and Storage section of this publication.) Although all modules are scheduled to be implemented at Tobyhanna, most users will only be utilizing two or three of the modules most applicable to their job.

The MSFS Inventory Module has been operational at Corpus Christi Army Depot since completion in May 1984. The hardware is interconnected in the hierarchial manner shown. The Central Processing Unit (CPU) has direct interaction with the LEMCOM I/O processor. The LEMCOM is connected to nine line controllers. The line controllers are connected to three types of devices: Okidata Printers, P300 printers, and Video Display Terminals (VDT). These devices are located in the shops that are using the MSFS. Each VDT is equipped with an attached Bar Code Reader (wand and INTERMEC), 25 Program Load Modules (PLM), and two Scanmark Bar Code Label Makers.

Additional information is available by contacting Mr. Don Smith, Tobyhanna Army Depot, AUTOVON 795-7641; Mr. Jack Brooks, Corpus Christi Army Depot, AUTOVON 861-3713; or Mr. Mike Ahearn, DESCOM, AUTOVON 238-6591.

PROJECTILE MANUFACTURING CONTROL

The US Army maintains a number of load, assemble, and pack lines at various ammunition plants. The melting and pouring of an explosive into a projectile is one of the most hazardous manual operations. In addition, the dedicated manual line is inflexible to changing production constraints.

Under Modernization Project 5 75 2626, contracts were let to Day & Zimmermann, Inc. and Pearce, DeMoss and Company to implement a computer controlled 105mm medium caliber projectile manufacturing line at the Lone Star Army Ammunition Plant (LSAAP). The system is responsible for directing projectile traffic through the line, controlling the explosive melting and pouring processes, sequencing machine operations, and maintaining a data base on the 800 projectile carriers on the line. The data base includes information on X-ray inspection results, cavity depth and diameter inspection results, lot number, and other quality control information.

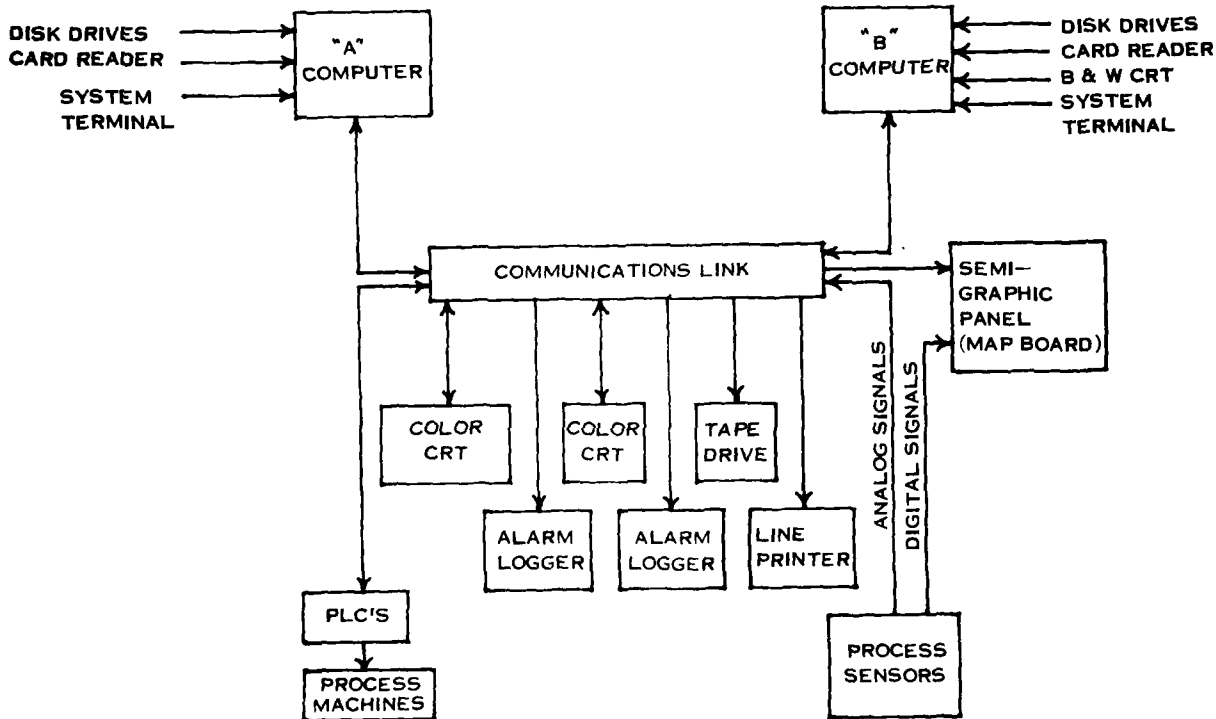

Control System Implementation

The heart of the line is a dual Taylor 1010 computer system as shown above. Each computer is completely redundant with 128K words of memory and 33 megabytes of disc storage. The machine operations are controlled through a network of seven Allen-Bradley Programmable Logic Controllers (PLC), and the carrier system is controlled by another five PLCs. Two

PLC programming panels are located in the control room. One is connected to the machine-control PLCs, and one is connected to the carrier-control PLCs. They are capable of making remote changes to the PLC programs when necessary and trouble-shooting equipment malfunctions remotely.

One of the advantages of this system is the improved quality control. Each projectile is brought to a specific temperature before it is poured. After pouring, the projectiles are cooled at a carefully controlled rate. The projectiles are then subject to as many as four automated inspections and three visual inspections. The facing machine drills the fuze cavities into the projectiles. This and the cavity depth and diameter inspection station are both unmanned. Shells that have been rejected by either automatic or visual inspections are automatically removed from the line to be recycled.

The projectiles are X-rayed to determine the quality of the pour cast. Normally, 10 percent of the projectiles are X-rayed at random. If a defective projectile is found, the system enters a 100 percent X-ray mode. The control room operator needs only to preset the number of projectiles to be X-rayed after a defect is found. The computer supervises the rest of the X-ray process.

The computer has complete control over the melt-pour process. Various temperatures, pressures, and valve positions are continuously monitored and displayed through a multiplexed analog system of sensors tied directly into the computer. The control room operator designates which pour units are in use and sets the temperature setpoints in the jacketed explosive piping. Temperatures, pressures, and valve positions are displayed on a semi-graphic panel in the control room and on CRT screen. Changes in process setpoints and valve positions are logged as well as alarms. Three levels of alarms, white, amber, and red, are monitored on the computer system. The semi-graphic panel is designed so that an operator can see the level and approximate location of any alarm. The exact location and alarm condition is printed out on one of two redundant data loggers and on a special CRT screen.

Work is continuing to prove out the line under PIF Project 5 83 9982. In the most recent activity, 3888 projectiles on 243 carriers were poured. Completion is expected in 4Q 1984.

Additional information is available by contacting Mr. David Self, LSAAP, AUTOVON 829-1305 or Commercial (214) 838-1305.

FACTORY AUTOMATED COMMUNICATION SYSTEM

The electromechanical data collection system at Rock Island Arsenal (RIA) has been wearing out for 16 years. It was purchased from Springfield Arsenal in 1966 and used until a year ago. It exhibited poor functional reliability and data inaccuracies. The difficulty was in knowing if a data collection transaction had been accepted and if it was accurate. The manual corrections, necessary because of the inaccuracies, increased as the system wore out. The old system gave erroneous readings, down time was considerable, and without a back-up system, the manual work required was extensive.

Under PSER Effort 6-6966, RIA has been purchasing and installing a Factory Automated Communication System (FACS) which will provide data input and output in manufacturing areas, inspection cribs, in-process store cribs, and selected office areas for the collection of information about production jobs for cost collecting and estimating purposes. The illustration below shows how the FACS manufacturing control functions interact.

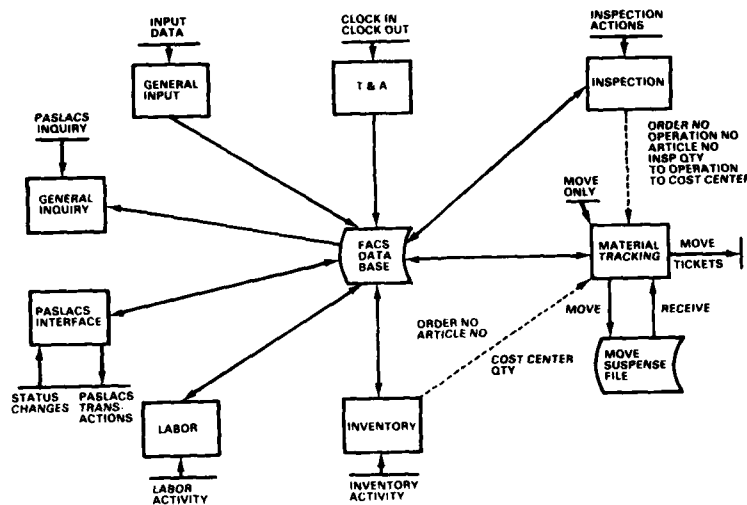

Control and Reporting Functions of FACS

FACS presently consists of two interconnected Tandem Nonstop II computers linked to the HQ, AMCCOM Business Computer System and 56 data collection terminals used for labor reporting. The expandable TANDEM computer system is slaved to a C3 Inc. controller. Each computer is linked and cross-linked to mirror image pairs of disk storage. If a computer or disk faults, the other will be scheduled to take over the entire workload. This significantly reduces the down time and lost information problems experienced with the old system.

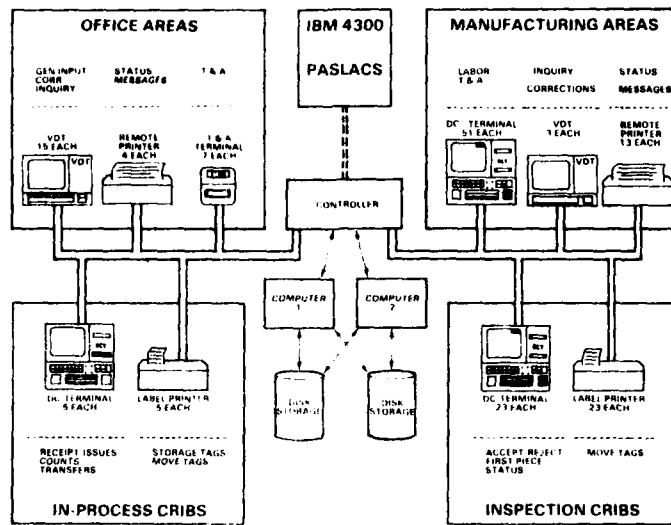

Hardware Implementation of FACS

The C3 Inc. labor data collection terminals (DCT) are located in the various manufacturing areas as shown above. When a production job is finished, the employee goes to a nearby terminal and inserts an identification card into the unit. The identification card allows the employee to access the system and transact the work performed. Once on the system, the employee inserts the appropriate job card, and machine card when required, into the terminal. There is one job card for each job and if for some reason the information isn't being accepted, an error message will flash on the screen and the employee makes the correction. If a card is lost or destroyed, an employee can key the information manually. Supervisory inquiry and corrections can be made through the 13 Control Concepts, Inc. video display terminals (VDT). The data received from the cards is stored in the FACS system and transmitted twice daily by wire directly to the HQ, AMCCOM Business Computer System (a major part of the PASLACS production control system) whereas before it was hand-carried after being transferred to magnetic tape. The benefits realized already from the new labor reporting capability are that the overhead hours have been reduced by 91 percent and the preparation and posting of manual labor transactions has been reduced by 69 percent.

The inspection and material tracking capability for the inspection cribs is scheduled for completion in November 1984. The hardware being installed for this capability are 23 more DCTs and 23 Dataroyal IPS - 7000-A label printers. The expected benefits are the elimination of manual preparation and keypunching input, immediate notification of "hot" parts ready for movement and on-line access to inspection and material tracking data.

The remaining phases of this project will add inventory reporting, time and attendance reporting, and open order status inquiry applications to the existing labor reporting function. When all currently planned applications are implemented, the total number of remote terminal devices (shop DCTs, VDTs, and printers) connected to the system will be approximately 160. Completion of the entire FACS system is expected in June 1985.

Additional information is available by contacting Mr. Scott Macomber, RIA, AUTOVON 793-6316 or Commercial (309) 794-6316.

700 ASSEMBLY

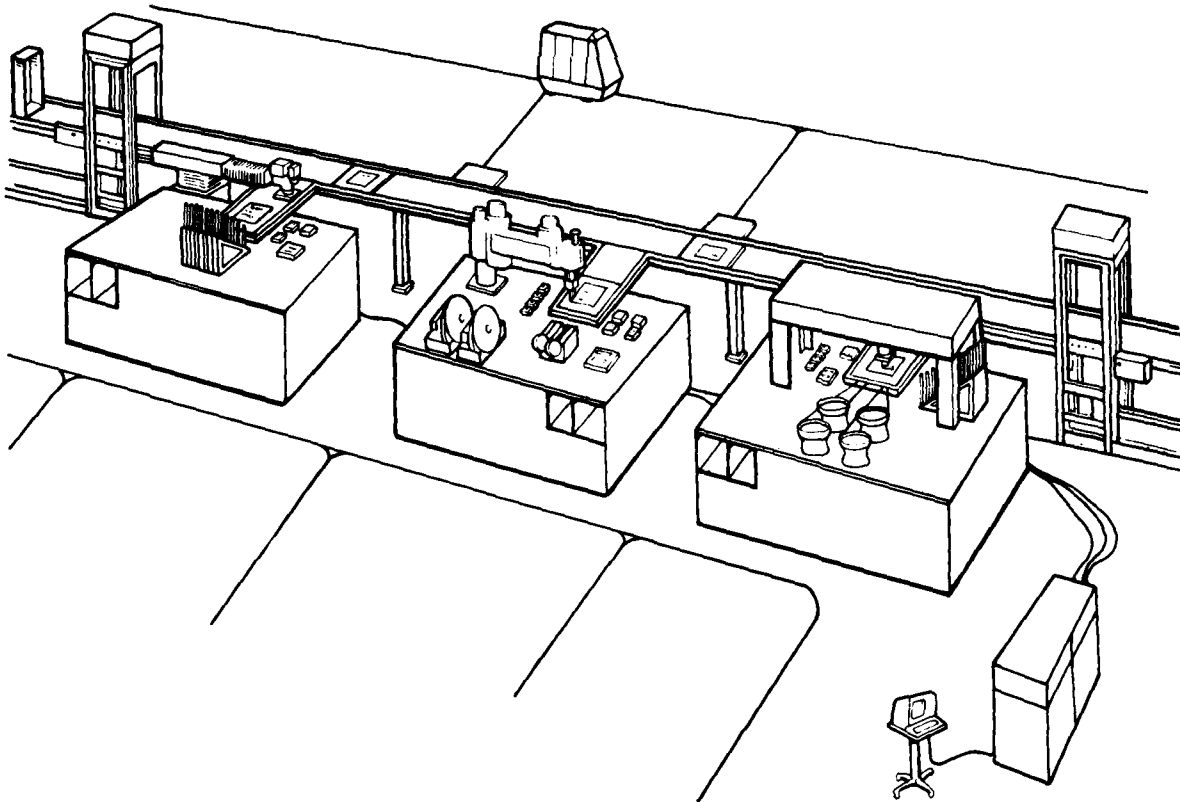

Electronics Assembly Operation

The integration of computer-aided technology into assembly operations is characterized by the use of robotics in workcells. Robots provide the most flexible form of automation and respond to changing workload and product mix. The increased use of robots introduces the need for improved programming languages, hierarchical control, end effectors and tools, sensing systems and machine intelligence.

The robotic workcell has functional similarity to a flow chart process block in that components are input, assembled products are output, control is from a remote source, and factory information is feedback to the controller. Assembly operations are found at a lower level of the Factory of the Future architecture.

AUTOMATED HYBRID DIE BONDER

The typical configuration of military hybrid circuits consists of an average of 10 to 15 different types of components. New designs are rapidly progressing to an average of thirty-five. The available computer-controlled optical pattern recognition equipment for the alignment of an electronic component to a hybrid substrate bonding pad was not able to recognize the topography of more than six or seven different chips on one substrate. This problem is primarily the result of software limitations. The probability of a missing or misoriented component was high.

Under MMT Effort 3-3219, the US Army Missile Command (MICOM) contracted Hughes Aircraft to design and develop a semi-automatic chip recognition die bonding system. The majority of work was done by Kulicke and Soffa (K&S) with Hughes in an overseer's capacity.

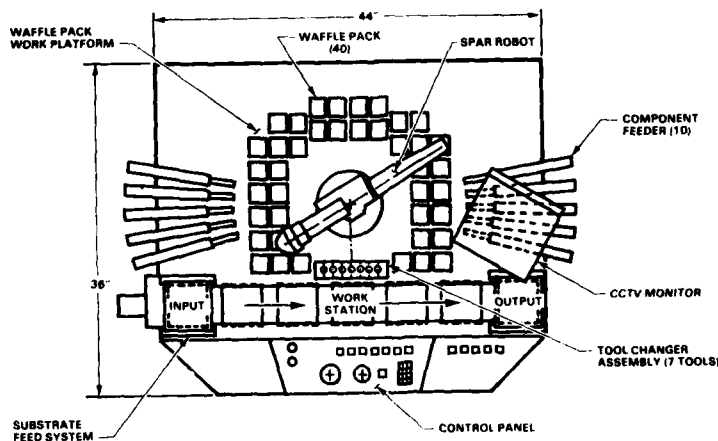

Automatic Hybrid Die Bonder

The resulting K&S Model 8500 Automatic Hybrid Die Bonder (AHDB) is an integrated system for automatic assembly of multi-chip hybrid circuits. The AHDB is shown in the above illustration. The system is designed for either semiautomatic or automatic operation and can interface with a host computer and CAD/CAM input data in an automated factory setting. It is especially suited to assemble a large number of different hybrid circuits of various lot sizes. It consists of a proprietary adjustable speed K&S Model 8101 Small Parts Assembly Robot (SPAR), a closed-circuit television (CCTV) system mounted within the robot's end-of-arm tooling, computer

controls, an automatic tool changing system, a motorized substrate magazine and feed system, optical means of identifying substrates and devices, and a work platform that accommodates up to 40 waffle pack chip trays and 10 passive component vibratory stick feeders.

The system's K&S Model 835R Pattern Recognition System allows the machine to run without an operator. It automatically aligns the substrate, picks up active and passive chip-type components regardless of their orientation in the waffle packs, and accurately places them in proper location and orientation on the substrate.

The machine also includes a Video Augmentation System to create graphic overlays which simplifies operator alignment of chips for semi-automatic operation. It is an external peripheral slaved to the main processor through an RS-232 serial interface. This subsystem has the capacity to store and manipulate up to 50 different chip types, with each chip having as many as 4 views.

The AHDB control system consists of a DEC PDP 11/23 host computer with floppy disk and Winchester disk drives which contain 11.8 megabyte storage capacity. This large capacity was included to handle the memory and data processing requirements for the normal programming and operation of the SPAR robot in various modes. The AHDB interfaces with host computers and accesses component identification and process control requirements. It provides ample capacity for a data base for a large number of chip geometries and waffle pack chip tray configurations.

The CCTV system displays software generated menus and prompts that make it easy for non-technical personnel to operate the machine or teach it the circuit assembly program. Once taught, it can function without an operator.

Software design for the complete AHDB is divided into two parts: robotics and hybrid die bonder. Robotics are controlled by the real-time multi-tasking disk operating system, KSDOS. This program controls and manages the computer memory, processor, and input/output facilities. All diagnostics and run-time security and safety features are under control of the robot. The hybrid die bonder control executive is the manager of all bonder processes. This program performs management of all die bonder operational modes (manual, teach/edit, auto, single-step, and diagnostic/set-up). The software was developed in PASCAL and Robot Control Language.

Under MMT Effort 3-1076, MICOM contracted K&S to build, test, and evaluate the AHDB system. The system will be operational and will be presented to industry via a manufacturing demonstration in a production environment in late 1984. The demonstration will be conducted at Hughes Aircraft Company facility, Tucson, Arizona, and the related hardware and software will remain in place at USAF Plant 44 at the completion of the demonstration for use by Hughes Aircraft Company. The K&S model 8500 AHDB has already been made commercially available. It is priced at about \$200,000 depending on options.

Additional information is available by contacting Mr. Milton Sulkowski, MICOM, AUTOVON 746-2147 or Commercial (205) 876-2147.

ROBOTIC WIRE HARNESS ASSEMBLY

Wire harness assembly is one of the most labor intensive processes in electronics manufacturing. The problem is compounded by the large variety of different harnesses. Current manual harness procedures utilize several stations and repeated material handling and transfer. Wires are prepared on a batch basis, stored in material buffers, and then routed to assembly stations where they must be identified before assembly. Approximately 50 percent of harness assembly time is devoted to handling, sorting, and identification. The actual harness assembly is done by hand.

Several semi-automatic and automatic machines have been developed which handle a limited combination of wire gauges, lengths, markings, and simple end preparation. They route and terminate wires using an X, Y axis machine table that is programmable with an overhead Z-axis rail system for wire laying. These machines perform well within their prescribed limitations, but lack the versatility and progressive domain growth potential necessary for general electronics manufacturing.

Under MMT Effort 3-1109, the US Army Missile Command (MICOM) let a contract to Hughes Aircraft in partnership with Unimation, Inc. for a feasibility study to investigate the application of robotics technology to the manufacturing of wire harness assemblies. The scope of the study plan was to investigate the domain required of a robot to make it cost effective, and to do preliminary design and model shop hardware construction which would establish the risk levels of the more difficult operations. A broad domain of wire/terminations combinations has been shown possible with robot performed operations.

MICOM subsequently contracted Boeing Aerospace Company to design a modular workcell, consisting of multiple robots, special equipment, commercial wire termination equipment, computers and associated peripherals, vendor software and application software integrated into a flexible system dedicated to the automated assembly of aerospace wire harnesses. The design of the Robotized Wire Harness Assembly System (RWHAS) has been completed:

- (1) The Data Generator generates the necessary process control data for each subsystem. Harness definition data are input either manually or from an existing data base, processed, and output to the system controller. The Data Generator host computer is directly connected with a MODEM capable of operating on dial-up lines. The printer will use a Centronics-type industry-standard parallel interface.
- (2) The System Controller controls all signals to and from the subsystems and provides the necessary operator instructions for material requirements and hardware setup. Data files transferred from the data generator to the system controller are distributed to the operational subsystems.

- (3) The Wire Preparation Subsystem selects the appropriate wire, marks the part number, and cuts it to the desired length with a Westland, Inc. laser cable marking system.
- (4) The Wire Reeling Subsystem reels the wire into a canister that provides wire end control and precision length measurement.
- (5) The Wire Termination Subsystem provides complete end termination of single conductor wires using an American Robot Corp. "Merlin" robot.
- (6) The Wire Queuing Subsystem stores canisters that have completed wire termination for layup processing.
- (7) The Wire Layup Subsystem routes terminated wires, inserts terminated ends in the appropriate connector, and ties the completed harness using an IBM 7565 robot.

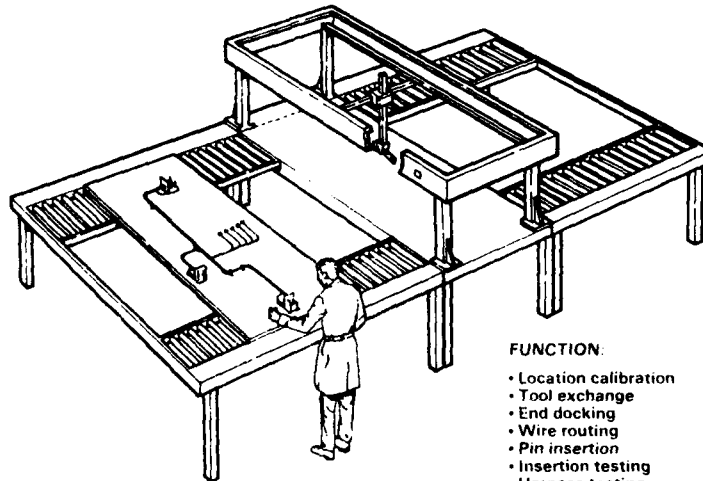

Wire Layup Subsystem of the RWHAS

The System Controller (INTEL 86/380) includes: an operator's console with keyboard and monitor, line printer, hard disk with a minimum of 9 megabytes, floppy disk, RS232 interfaces, parallel I/O ports, modem and interface, and a minimum of 128K words of memory.

The System Controller vendor software includes: a multi-tasking operating system, text editor, high level language, assembly language, linkage editor/loader, RJE utility, and the necessary run-time libraries.

The application software includes: an interrupt handler, error handler, task monitor, Data Generator interface, user interface, equipment inventory, system set-up, report generator, and harness fabrication routine.

Boeing Aerospace has been awarded a contract to build the RWHAS. The automated wire harness assembly module is a development for one of the commodity areas the Army has selected from the ECAM Master Plan (covered in the Architecture section of this publication). Upon completion of the RWHAS effort in the 3rd Quarter 1985, the modular system will be able to integrate into the Electronic Factory of the Future model envisioned in the ECAM effort. The RWHAS is expected to be available commercially for purchase.

Additional information is available by contacting Mr. Mike Anderson, MICOM, AUTOVON 746-2147 or Commercial (205) 876-2147.

800 SIMULATION, MODELING & OPERATIONS RESEARCH

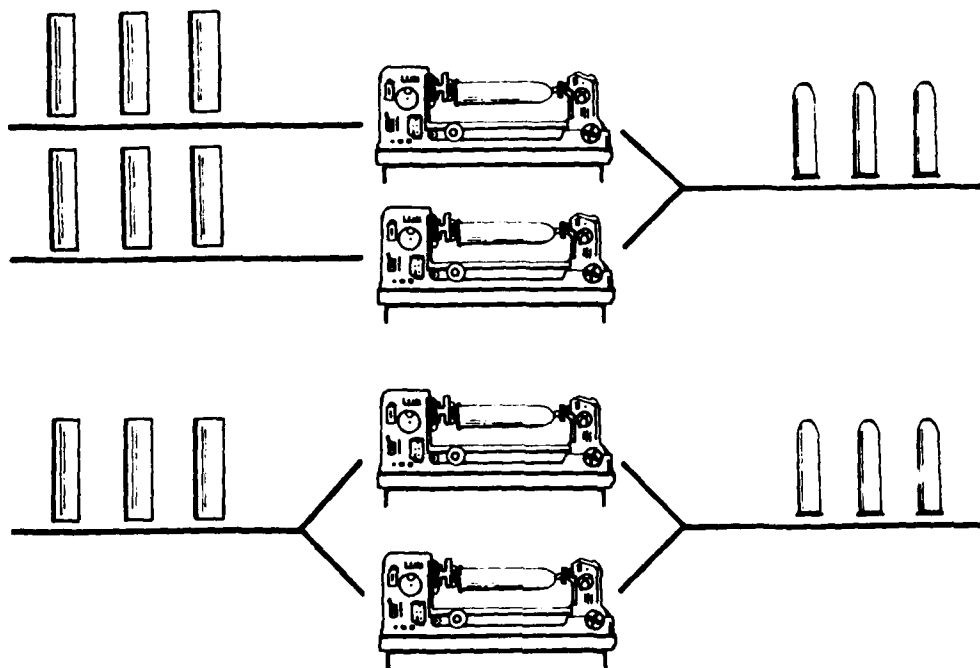

Simulation, modeling, and operations research is the soft technology for optimizing manufacturing systems. Each module of a manufacturing system may be simulated and optimized with the goal of having an all encompassing simulation and optimization such that it may be used as a model reference baseline for factory operations. Analytic and stochastic models with varying inputs and constraints are the most often employed.

SIMULATION OF METAL FORMING

The manufacturing of artillery shells typically involves a series of metal forming, machining, and heat treating operations. Depending on the metal forming process (hot, cold, or a combination), the billet is obtained either by nicking and breaking, sawing, or shearing. Then the billet is formed by the cabbaging, piercing, drawing, and nosing processes. Since no predictive technique existed for coordinating the design and optimization of each metal forming operation, there was: no commonality of tooling between plants, a large amount of unnecessary initial engineering effort for preparation of technical data packages, no prediction of metal part failure during forming operations, and no optimal design of the production line.

Under MMT Effort 5-6716, the US Army Armament, Munitions & Chemical Command (AMCCOM) contracted Battelle and Chamberlain Manufacturing Corp. for the development and confirmation testing of computer models of the blocking, cabbaging, piercing, drawing and nosing operations, and to consolidate them into a comprehensive system of programs.

The resulting system is a set of integrated modular mathematical models: CABBAG, PIERCE, DRAWNG, NOSING, CDVEL, and VOLUME. CABBAG simulates the cabbaging operation; PIERCE simulates the piercing operation; DRAWNG simulates the drawing operation; NOSING simulates the nosing operation; CDVEL designs the streamlined-die for the drawing operation; and VOLUME calculates the volume or dimensions of the initial billet.

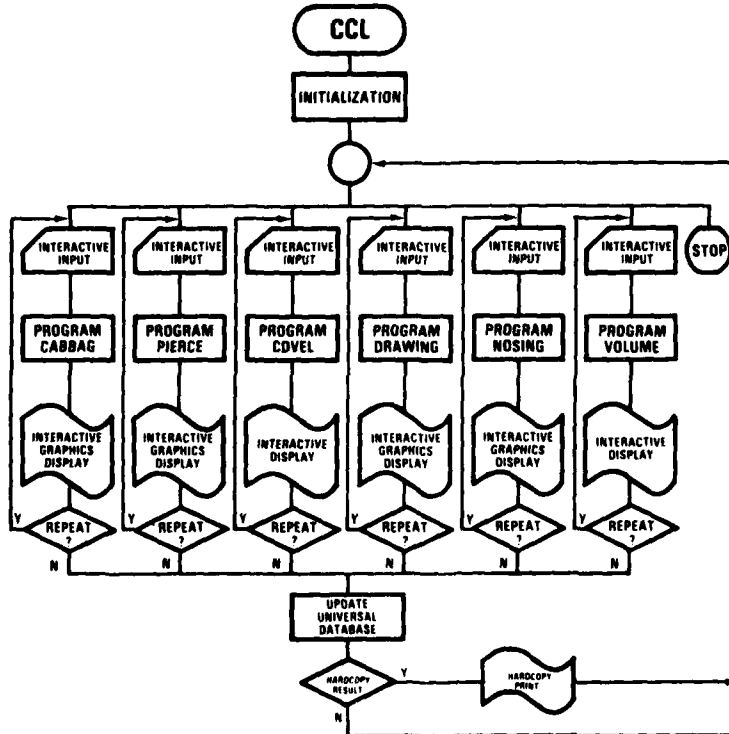

Interaction of Simulation Software Modules

The modules are linked by a monitor program, CCL, which directs the flow of data and program execution as shown in the illustration. The user exercises control of the system through CCL and is able to execute each of the modules individually to simulate a single operation or as a system to simulate an entire production line. The system works well for both cases. When executed as a system, input/output are drawn from a universal data base which is generated at the execution of the first module (usually NOSING) and is updated after the subsequent execution of any of the modules. Iterations can be performed until the process is optimized. The system is now operational on Battelle's CDC 6000 computer with interactive graphic capabilities.

The validity and accuracy of the nosing model were tested under a near production environment at both cold and hot working temperatures. The cold tests were conducted on the 105mm M60 shell at Chamberlain, Waterloo, Iowa. The hot tests were conducted on the 155mm M107 in Chamberlain Manufacturing Corporation's Scranton, PA Division under production condition.

Computer predictions of the cold nosing operation were generated by the NOSING model. The correlation between the predicted and load-stroke curves and shell thicknesses was good. Furthermore, as predicted by the model, all 45 as-nosed shells passed Chamberlain's quality inspection.

Computer simulation was generated for the hot nosing operation. Excellent correlation was found between the actual and simulated metal flow. The actual and simulated cavity volumes of the as-nosed shells correspond within 0.5 percent. The predicted load-stroke curve is found to be somewhat higher than the measured valves due to a slight temperature profile variation. All shells produced in the nosing tests passed Chamberlain's production inspection.

The cabbaging and piercing models were validated by confirmation tests conducted under production conditions at Chamberlain, Scranton, PA. The shell selected for these tests was the 155mm M107. The actual production tooling, lubrication, and other techniques were used. Simulation of the metal flow during the cabbaging operation was performed and the load-displacement curve was calculated using CABBAG. The measured experimental and calculated load-stroke curves were compared and the agreement was found to be excellent. Simulation of the piercing operation was performed which showed good correspondence between the load-stroke curve and the experimental curves.

With this system, shell production engineers will be able to determine the metal flow which occurs during these metalforming operations and analytically calculate the required forming load, stress/strain of the material, preform configurations, and the toolings and process variables for each of these operations. In addition, with the predictive capability of this system, the formability or producibility of future items can be accurately assessed during the design phase before commitment to production.

Effort is currently underway to transfer the system to the AMCCOM CDC computer so that it will be available to potential AMCCOM/industrial users. The possibilities of conducting a users training course is also being investigated.

Additional information is available by contacting Mr. Fee Lee, AMCCOM, AUTOVON 880-7912 or Commercial (201) 328-7912.

REARM PRODUCTION LINE SIMULATION

In the early stages of the Watervliet REARM project, facility designers were analyzing the manufacturing lines and trying to justify the proposed manufacturing equipment. In order to perform the analysis, a computer simulation was needed but the available simulation packages were not capable of handling the complexity of the REARM project.

A mathematical model of the REARM manufacturing lines was developed by the US Army Armament, Munitions & Chemical Command (AMCCOM) under REARM planning funding. The computer implementation was written in FORTRAN IV for an IBM 370. Inputs to the model include the steps required to transform raw material into a finished product and the resources available for production. From these data, the model will predict such things as the number of items produced by the line, utilization of machines and workers, and areas where the number or quality of the resources are not adequate to meet the desired production goals.

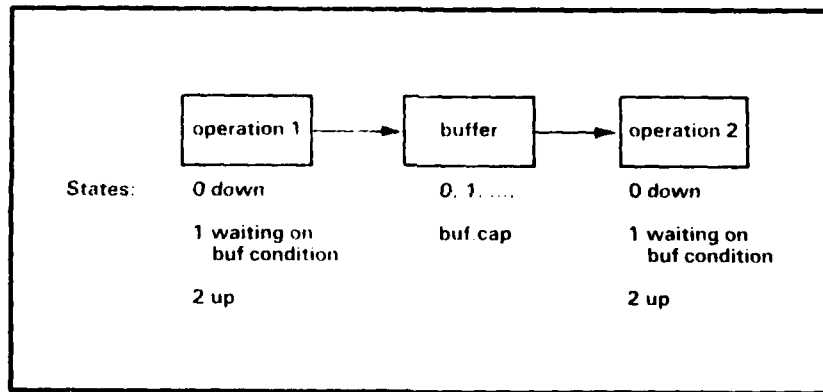

Box Model with Buffer Queue

The simulation uses a box analogy to conveniently describe equipment modules as shown above. The product components are considered to be in batches which may or may not consist of only one item. Each box has a maximum and a minimum batch input. Each box's maximum capacity is the largest number of items that can be in the box at one time.

Equipment breakdown and maintenance are not distinguished in the model. These are considered together as random variables with an exponential distribution. This gives a reasonable approximation to the historical breakdown data.

Workers are organized into "crews" and "shifts." The crew concept is a way of modeling the division of workers by skill and location. Each crew has the responsibility for certain tasks and is defined by the tasks assigned to it. A task is assigned to a given crew and a worker can perform only those tasks assigned to his crew. Every worker is assigned to only one crew. However, within a crew, each worker is considered interchangeable with any other member of his crew. The shifts model the behavior of workers over time. Normally there are three shifts, although the model makes no assumptions about the number of shifts.

Jobs are divided into two categories: continuous and halting. Halting jobs are those that can be stopped at any time and then be resumed later after possibly some delay. If the job is an operation, then the items on the halted box remain in the box and are not returned to queue. When a halted job is resumed, it is taken up from the point where the halt occurred.

Continuous jobs are those that, once started, must be completed with no interruption. The first priority of the incoming shift is to relieve all workers on continuous jobs. If there are not enough workers to do this, then as many workers as required from the outgoing shift are detained so that all active continuous jobs are covered.

The last major element of the model are the queues. There is one queue for each step in each production process. The queues are assumed in the model to be as large as they need to be.

The computer program PRDLN exercises the model for a real or planned production line. Input data to the program consists of descriptions of the production processes, facilities, and workers. Output from the program includes production figures, facility and worker usage, and queue data to identify "bottlenecks" in the system. Raw items enter the system at a predefined rate and have a sequence of production processes assigned to them. For each process step, the item may pass through one of many pieces of equipment. It stays there during the process time and then moves on to the next step queue. A conflict of two candidate items to be processed by the same equipment is resolved by a priority assignment.

The model and its computer implementation have been tested with satisfactory results on real-life data from Watervliet Arsenal. The model was able to identify problem areas correctly, and to give reasonable predictions for production figures.

Additional information is available by contacting Mr. Eugene Coppola, Benet Weapons Lab., AUTOVON 974-5256 or Commercial (518) 266-5256.

SIMULATION OF AMMUNITION PRODUCTION LINES

The Department of Defense (DOD) typically acquires new or improved ammunition production facilities under a contract with the plant's operating contractor. After debugging a new line--generally, on a machine-group-by-machine-group basis--there exists substantial uncertainty whether the production capacity of the line meets or exceeds its assigned mobilization capacity. Experience indicates that often the actual capacity of a line, after acceptance by DOD, falls short of its projected capacity. One reason for this situation is that it is not considered economically feasible to prove out an entire line under realistic mobilization conditions.

Faced with the problem of estimating the mob capacity of a line without being able to conduct a realistic test, one must use mathematical models for this purpose. Analytic models cannot cope with the manifold complexities that characterize actual production systems so DOD must resort to stochastic (Monte-Carlo) simulation.

It is desirable that the computer code for such a simulation be as flexible as possible, in several senses: (1) Program code should admit a variety of line structures without reprogramming. (2) If reprogramming is necessary to accommodate special features, the program language should facilitate this without major recoding. (3) The model should treat all production resources in a comprehensive and coherent manner. (4) The program should permit events to be traced and statistics gathered on interesting events. (5) It should provide an appropriate statistical analysis automatically without additional burden to the program user. (6) It should include a capability to verify the correctness of outputs, and to display statistics which can validate the model.

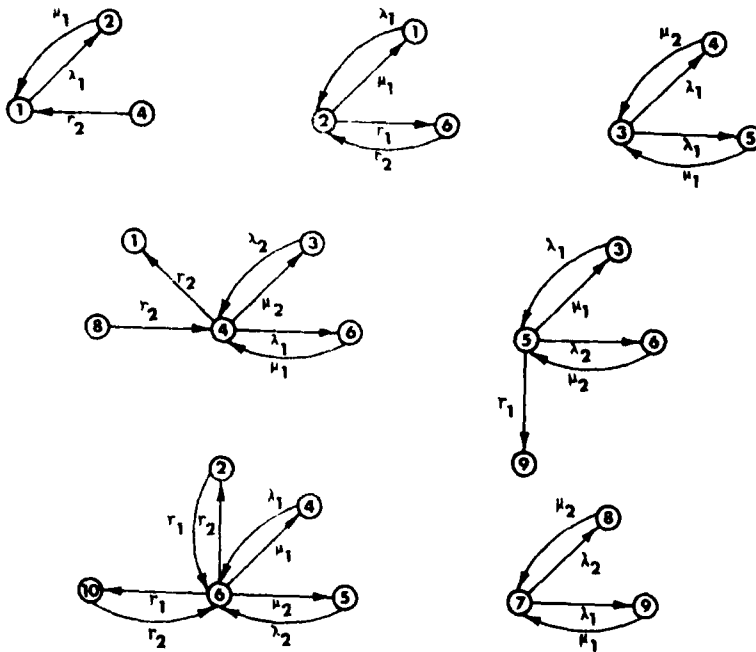

Simulation State Diagrams

Due to inadequacies of existing production simulations, the US Army Armament, Munitions & Chemical Command (AMCCOM) developed a discrete-event simulation called TANDEMT under internal OMA funding. Particular emphasis was placed on the statistical analysis and interpretation of simulation statistics. Analytic models, using the same data base as the simulation, run concurrently. It exploits the Simgcript II.5 compiler which had only recently been written for the Prime minicomputer.

The simulation and associated analytical/statistical programs provide information for the design, analysis, and statistical testing of a production system organized conventionally with serial processes. TANDEMT is also capable of treating T-configurations, i.e., merging of parts' branches, as well as straight in-line systems. Input of data is interactive with prompting messages given to the program user at the terminal. For simulating elaborate systems, it is preferable to input data from a file rather than to interact via a terminal, although the latter option is preserved. A finite-state Markov queueing model is used to analytically describe the behavior of the machine repair system prior to actual simulation. Analytic models of this scope are both tractable and useful as a simulation check. After executing the simulation, the sample statistics are compared with the analytic results. Because most lines are not balanced, it is useful to calculate and display certain analytic quantities which are helpful in identifying choke points and which can be correlated with subsequent simulation results.

The simulation output statistics reported daily are: (a) acceptable parts produced, (b) total rejects from all machine types, (c) within-replication time-average number of machines down, (d) within-replication time-average and -standard deviation of machine repair queue, (e) within replication average and standard deviation of number of busy machine repairmen, (f) within-replication probability that a failed machine must queue for service, (g) replication-sample probability distribution for time between output of units, (h) replication average and standard deviation of inter-output time and (i) the replication-sample autocorrelation functions of the parts' production rates.

Daily totals of net parts production and in-process rejects over all replications are used to estimate the probability distributions of these quantities via order statistics. Quantiles of these quantities can be calculated and printed as well as confidence limits for the mean values. Comparisons can be made between sample statistics for the utilization of repairmen with the analytical probability distribution.

Applications of TANDEMT have been made to various modules of the M483/M509 projectile lines at Louisiana AAP and Mississippi AAP. These included both LAP and metal parts. Additionally, the simulation was run for various test cases for comparison with analytic models. Although debugged and verified, this program involves modeling assumptions which have not been validated against full-scale production experience.

Additional information is available by contacting Mr. George Schlenker, AMCCOM, AUTOVON 793-5041 or Commercial (309) 794-5041.

900 MATERIALS HANDLING AND STORAGE

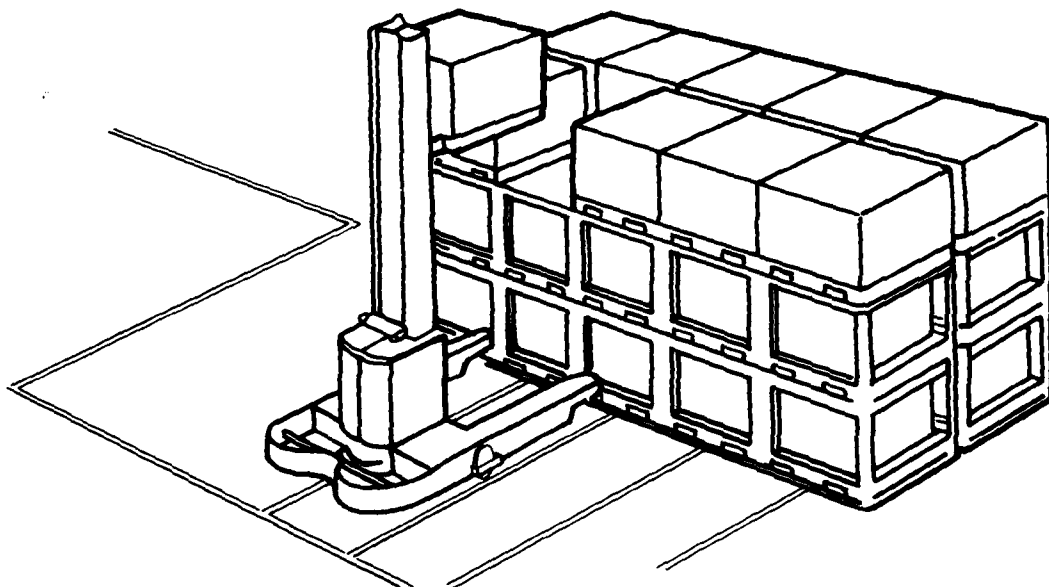

Pallet Storage System

This area involves the integration of computer aided technology with material handling and storage to comply with OSHA and EPA standards and to reduce costs and time associated with materials handling. Automated material storage, handling and retrieval systems in Army facilities are receiving a great deal of support. This is due to the Army's need to maintain a ready inventory of weapon system components. This philosophy is also being implemented in the Army's manufacturing facilities.

DEPOT AUTOMATIC STORAGE AND RETRIEVAL SYSTEM

Concurrent with the initiation of the Standard Maintenance Shop Floor System Program described in the Manufacturing Control section of this publication, the US Army Depot Systems Command (DESCOM) also initiated a study of maintenance oriented materiel handling capabilities at certain user depots. This study identified a dramatic need to upgrade these facilities during the 1980-1990 timeframe. Tobyhanna Army Depot (TOAD) was assigned lead responsibility for not only the study and cost analysis, but also the development and implementation of a prototype system. It was determined that this system would be the location and storage element which supplements the Maintenance Shop Floor System. Subsequent to the project at TOAD, the material handling and storage system would be installed at other DESCOM major maintenance depots such as the Anniston system illustrated below.

Early in the DESCOM Automatic Storage and Retrieval System (ASRS) Plus Program, it was decided that establishing performance specifications, rather than fixed designs, was the desired approach so that supplier innovation could be obtained to the fullest extent. These performance specifications were planned for each depot, individually, by contractors with an in-depth background in materials handling. The performance specifications were prepared to allow turnkey procurement of the entire depot ASRS Plus project.

There was potential for some standardization of the control systems, however, total standardization of the control systems looked impossible. It was established as an ASRS Plus policy that the control portion of the TOAD ASRS Plus performance specifications (the first project) would be a prototype for the other depots.



Under the Asset Capitalization Program 83-FA01, Eaton Kenway, Inc. was contracted to design, install, and maintain an ASRS Plus at TOAD which has a 3-1/2 year payback. The resulting system is composed of a Materiel Control and Information System and a Materiel Handling and Distribution System.

The Materiel Control and Information System is a mini-computer system consisting of the hardware and software necessary to handle the requisition, information, and accountability of Maintenance Mission materiel. Specifically, this computer and peripheral hardware must control the ASRS and AGVS (Automated Guided Vehicle System) systems, store all associated tables and files, print reports and system status, and provide ASRS computer to Host computer communications.

The Materiel Handling and Distribution System consists of five elements: a pallet load storage system for medium size parts, a mini-stacker storage system for small size parts, an oversize and floor storage system, conveyor transportation systems, and an automated guided vehicle system.

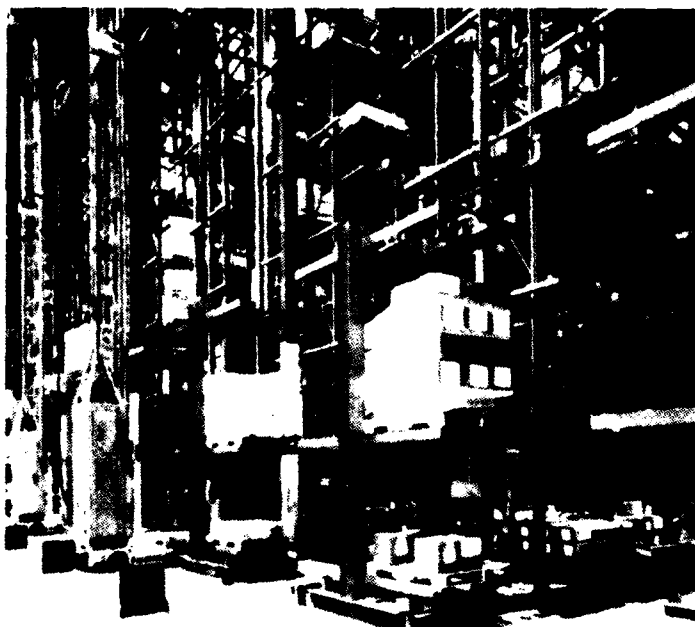

Pallet Storage System

The Pallet Storage system, such as the one shown above, is a rack support structure containing six aisles of storage. Each aisle is segmented into horizontal bays and vertical tiers with each of its 4,548 openings having a discreet address. The storage/retrieval machines used in this area will be man-ride vehicles with a fixed mast capable of carrying 2000 pounds at a height of 526'.

The Mini-Stacker storage system is a rack supported structure also containing six aisles of storage. The 24x48x6 or 12 inch mini-stackers trays may be subdivided into as many as 32 separate compartments. Each of the 13,224 trays will be given a unique ID identified by a bar code label attached to one side of the tray.

There will be six storage/retrieval machines (one for each aisle) in this area. These machines, capable of carrying a maximum tray weight of 500 pounds, have a horizontal speed up to 366 feet per minute and two vertical speeds of 108 and 27 feet per minute. Each machine has the capability of accessing storage bins on either side of the aisle and is equipped with photocells to detect misaligned loads or uncentered trays. Each mini-stacker aisle is equipped with a microprocessor which will be the distribution point for messages sent to the storage/retrieval machines. Each storage/retrieval machine will in turn decode the messages and carry out its proper functions.

The Large and Oversize item storage consists of 13 rows of cantilever racks with multiple configurations, floor storage, side loader vehicle for cantilever rack and fork truck vehicle for handling loads in floor storage. There will be three (3) sizes of cantilever racks with 50 bays of each size. The side loader vehicle furnished for these racks will have a maximum speed of 4.5 mph and a load capacity of 10,000 pounds. The side loader vehicles will be guided by polyurethane wheels located at each corner of the vehicle. These wheels will roll against metal guide rails along the base of the rack, thereby eliminating the need to steer the vehicle and allowing it to travel at full speed.

There are three (3) separate and independent conveyor systems which will be used by the ASRS Plus. These are the MRA (Maintenance Receiving Area) package conveyor, the tote conveyor, and the tray conveyor. The MRA package conveyor will deliver corrugated containers varying in size from 6x6 inches up to 24x24 inches. This conveyor will run from the video input processing station (VIPS) where materiel is received and documented by Receiving to the MRA. The speed of this conveyor will be approximately 60 feet per minute.

The Tote Conveyor System will transport full and empty totes between MRA and the Mini-Stacker/Distribution Area. The system includes a continuous moving overhead enclosed track conveyor loop with six (6) input/output stations interfacing it. Tracking in this system will be done using photocells and a fixed bar code scanner at station 1 to read carrier ID's. The totes used in this system will be made of plastic and have a capacity of .83 cubic feet.

The Tray Conveyor System is provided to move trays in and out of the Mini-Stacker storage system. The system consists of a conveyor loop with storage/retrieval machine input/out stations and operator work station modules interfacing the loop. Trays will be positively tracked on the conveyor system using photocells.

The AGVS used for materiel distribution is divided into two sub-systems. The two systems use separate guidepaths and are independent of each other. The primary system will be handling cart modules and pallets up to 2000 pounds. The secondary system will be used to deliver materiel to work centers in the Electronic shop from an adjacent staging area. The primary system will use a wire guided path while the secondary system will use a fluorescent paint for its guidepath.

The Primary AGVS consists of a control system, guidepath, and 16 Eaton-Kenway XR Narrow Aisle AGV's. Three frequencies will be present in the guidepath wire; two for guidance and one for vehicle communications. The control system is broken into two areas. The first area will handle the communications to the manager and vehicle scheduling, while the second will handle move commands from area 1, process the move commands, and communicate to the vehicle the moves required.

The automated guided vehicle itself is a Eaton-Kenway XR Narrow Aisle Fork Truck. This is a driverless, bi-directional vehicle with 2000 pound capacity and a forward speed of 220 feet per minute and reverse speed of 60 feet per minute. The load and forks of the vehicle trail the vehicle when it is traveling along in the forward direction.

While the TOAD ASRS Plus is totally new from the ground up, the other depot systems have different approaches. The Letterkenny, Red River, and Anniston systems are upgrades of older ASRS systems. The Sacramento system will be totally new hardware in an existing building.

The entire TOAD ASRS Plus system is scheduled for completion by November 1985. The other systems are in different stages of development. The Sacramento system is contracted. The Red River and the first half of the Letterkenny system are expected to be contracted by the end of 1984. Corpus Christi and Anniston have completed their performance specifications.

Additional information on the total Army ASRS Plus effort is available by contacting Mr. John Pace, DESCOM, AUTOVON 238-6591 or Commercial (717) 263-6591. For information on the TOAD ASRS Plus, contact Mr. Jerry Collins, TOAD, AUTOVON 795-7771 or Commercial (717) 894-7771.

1000 TEST, INSPECTION AND EVALUATION

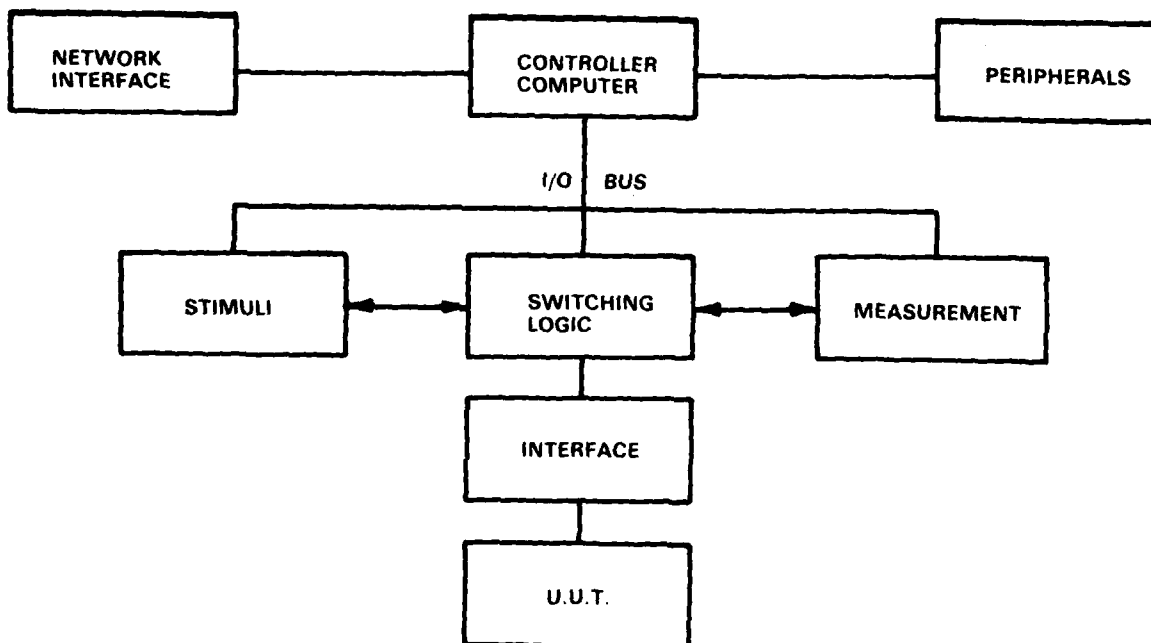

Modular Test and Inspection System

This thrust area addresses real time, computerized, nondestructive testing techniques for use in fabrication and assembly operations. Emphasis is put on automatic in-process inspection, accept/reject decision making, and failure disposition. Test systems tend to be modular in nature and are encountered at many points in the manufacturing flow. Incoming material inspection, in-process test, and final product test are on a lower tier of the Factory of the Future architecture but are tied in with the higher order technologies such as the manufacturing control system.

INTEGRATED BLADE INSPECTION SYSTEM

The inspection requirements for the Army, Air Force, and Navy's engine airfoil blades and vanes specify a high degree of accuracy, reliability, repeatability, and thoroughness. The features to be inspected include contour, grill holes, internal and external surfaces. The conventional inspection methods currently employed, such as visual, airflow, waterflow, and probe are performed manually and are subject to human limitations. Consequently, a number of flawed parts pass inspection and are incorporated into engines. The costs associated with the assemble, tear-down, repair and reassemble cycles can be very large.

Under MMT Effort 1-7371, the US Army Aviation Systems Command (AVSCOM) contracted General Electric Company jointly with the Air Force and Navy to establish the Integrated Blade Inspection System (IBIS), a computer-based, automated system for the precision inspection of individual airfoil parts.

The IBIS system illustrated below is comprised of four automated inspection modules, interconnected through a computerized data management network. Each module is designed to perform a specific type of inspection required during manufacture and overhaul of stationary and rotating airfoil parts. The system utilizes many well-defined, structured design techniques, including the Air Force Integrated Computer Aided Manufacturing project's IDEFO.

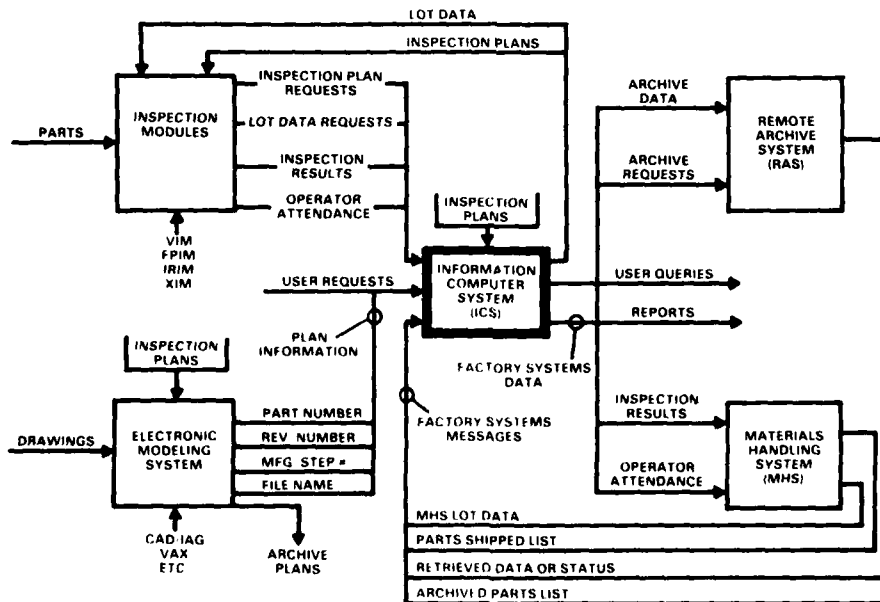

IBIS Interfacing

The IBIS system is programmed with a geometric model of the airfoil part to be inspected from the manufacturer's design data base. An inspection plan is then developed using the Information Computer System (ICS). This plan is stored in an inspection plan data base. When an inspection plan is needed by an IBIS module, the plan is down loaded into the module. The module automatically performs the inspection process. The part disposition decisions reported by the inspection modules are entered into the airfoil part data base of the ICS. The data base serves as the source of data for reports and analyses used by quality, manufacturing, and overhaul organizations. The content of this data base also will be accessible by the module user through a query facility in the system. Through it, data concerning particular lots of airfoil parts will be available on an interactive basis. After an airfoil leaves a manufacturing or overhaul facility, its history can be transferred to archives within the ICS or at an external facility. The archives provide for long term retention of airfoil part inspection data.

The Visual Inspection Module (VIM) inspects for airfoil surface defects, such as dents, nicks, and scratches at a peak rate of 500 parts per hour. These indications are detected using an optical profile sensor. A VIM minicomputer system provides overall supervision of module processes. It controls part and sensor manipulation, provides decision-making for flaw interpretation, and serves as an on-line data base.

The Fluorescent Penetrant Inspection Module (FPIM) inspects for surface flaw indications at a peak rate of 500 parts per hour. The FPIM and the VIM are similar in design, construction, and performance. The main hardware differences between the FPIM and VIM are in the sensor and preprocessor. The FPIM sensor uses a helium/cadmium laser to excite the penetrant phosphors and a photomultiplier tube to measure the resultant fluorescence. The FPIM preprocessor is concerned only with flaw fluorescent light intensity and its location.

The Automated Fluorescent Penetrant Preprocessing Module (AFPPM) automatically applies fluorescent penetrant materials to airfoil parts. The AFPPM processes an average of 1,500 parts per hour for subsequent inspection by the FPIM.

The X-Ray Inspection Module (XIM) is being established to perform filmless X-ray inspections. In the digital fluoroscopy mode, the XIM will inspect at an average rate of 60 parts per hour which is approximately three times faster than current manual methods. The system is being configured such that the average through-put can be upgraded to 120 parts per hour. The computerized tomography mode, while slower, results in a cross-sectional image and is better able to resolve internal structural flaws and reveal flaws partially or completely masked in the fluoroscopic data format.

The Infrared Inspection Module (IRIM) is an automated inspection system being designed to replace existing manual airflow and waterflow inspection methods for air-cooled airfoil parts. The IRIM utilizes infrared thermography techniques to detect cooling flaws in air-cooled parts at a rate of 500 parts per hour. It is capable of detecting thermal conditions attributable to these flaws both at the surface and within internal passages of the part.

The initial IBIS system is planned for installation at the Air Force's San Antonio Air Logistics Center, San Antonio, Texas for the F-100 engine. (The only exception is the X-ray Inspection Module (XIM) which will be installed at the engine manufacturer's plant.) Recently, the first module, FPIM was delivered, installed, and is undergoing verification testing. IRIM and VIM are scheduled for installation in 1985 and 1989 respectively. Once the IBIS program has been completed, the Army may purchase the IBIS system and software for the T-700 turbine engine inspection at Corpus Christi Army Depot.

For additional information, contact W. Brand, AVSCOM, AUTOVON 693-2294 or Commercial (314) 263-2294.

AUTOMATIC INSPECTION DEVICE OF EXPLOSIVE CHARGE IN SHELL

The Army's Production Base Modernization Program for ammunition plants includes requirements for high rate inspection of 105mm-155mm HE projectiles to detect critical cavitation defects. Explosive defects in artillery shells is a safety hazard and would require 100 percent inspection. The 100 percent inspection with current inspection techniques is not economically feasible due to high labor and film costs. Of equal importance is the limited reliability of conventional manual radiographic inspection. The continued use of film inspection carries with it inherent time delays and the use of many inspection personnel in explosive production line environments.

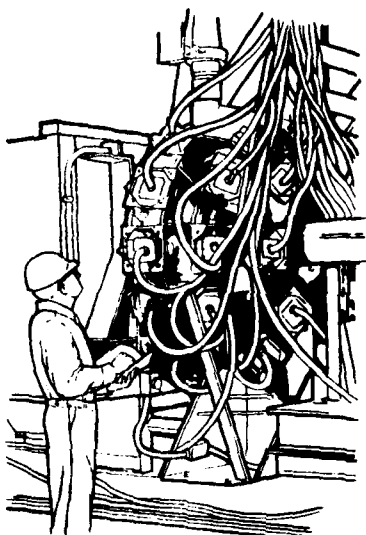

Inspection Subsystem

Under MMT Effort 5-4454, the US Army Armament Research and Development Center (ARDC) contracted IRT Corp. to design, fabricate, and test a filmless, real-time, automated X-ray inspection system using existing state of the art technology. This effort produced an Automatic Inspection Device for Explosive Charge in Shell (AIDECS) pilot production prototype system for inspection of the whole spectrum of Army ammunition from 40mm to 8-inch rounds. AIDECS utilizes Compton scattering to analyze the explosive filler and can detect base gaps of as small as .030 inch and voids that have diameters as small as 1/16 inch. The computer software recognizes flaw patterns and compares the data to previously established limits for automatic accept/reject decisions. The prototype system is comprised of four subsystems. These are: Control, Mechanical Handling, Inspection, and Data Processing Subsystems.

The Inspection Subsystem shown in the illustration above provides the means to irradiate the shells and detect the Compton-scattered radiation. It is comprised of five major assemblies. The Bremsstrahlung source assembly provides irradiation of the shells. The detector/collimator structure assembly provides detection of Compton-scattered radiation using modular tapered multihole focusing collimators. The exit port and beam stop assembly provide shielding of the primary beam after it has passed through the shell. The support mounting frame assembly provides support for the components of the Inspection Subsystem. The outer enclosure assembly provides protection of the Inspection Subsystem components from the environment and assists in rendering the subsystem explosion-proof.

The Mechanical Handling Subsystem provides loading and unloading of the shells and moving the shells through the scan pattern. It is comprised of the lifting carriage, lifting frame, shell holding kit, hydraulic power, load/unload, and outer enclosure major assemblies. The load/unload assembly provides for the loading and unloading of the shells, whereas the other assemblies enable movement of the shells through the scan pattern. It was designed to accommodate a scan time of 1 minute for the M549 155mm shell, and be quickly retrofitable to handle shells up to 8 inches in diameter, 36 inches long, and weighing 200 pounds.

The Control Subsystem provides system initialization, operator's interface, sequencing of subsystem operations, conversion of detector data into a form suitable for processing, system abort, system shutdown, and self-check for maintenance and safety. The Control Subsystem is comprised of three hardware major assemblies and one software major program. These are the operator's console and equipment racks, monitoring and control hardware, data acquisition and conditioning hardware, and controller software. The Control Subsystem not only ties all of the subsystems together, but provides the primary control over the entire system.

The Data Processing Subsystem collects and normalizes the raw scan data, analyzes the data, determines defect types and whether the shell is acceptable, prepares the shell status report, archives the results, and performs subsystem maintenance. The Data Collection Hardware consists of: a DEC PDP 11/44 computer, two DEC RLO2 hard disk drives, a DEC FPIIF floating point processor, and an RSX-11M operating system. The four major software programs within the subsystem are Data Collection and Normalization, Data Analysis and Defect Classification, Report Generation and Archiving, and Subsystem Maintenance. The Analysis and Classification software is written in FORTRAN IV for the PDP 11/44.

The AIDECS color graphics display utilizes processed data and creates several different images of the defect information. Each color within the display represents a different density of the charge material.

Therefore, a quick perusal of the image shows the type of defect and how it varies with density. Defect information can be displayed in a three dimensional projection that rotates, translates and zooms. Tomographic type slice displays can be generated and used to gain quick insight into the results of analysis changes as well as a process control.

The AIDECS pilot production system resides at ARDC's newly constructed high technology radiographic testing facility. The production design concept and performance specifications are currently being used to design the production equipment. Once completed, PIF Project 5 87 2222 will implement the results of this effort at the Iowa Army Ammunition Plant for the inspection of M549 projectiles. Also, because of recent discussions of reactivating the 105mm production, the AIDECS system may be installed at Lone Star Army Ammunition Plant.

To obtain more information, contact E. Barnes, ARDC, AUTOVON 880-4274 or Commercial (201) 724-4274.

AUTOMATIC INFRARED TEST AND INSPECTION SYSTEM

In the fabrication of electronic components and the assembly of printed circuit boards (PCB), certain flaws can cause an abnormally high localized power dissipation. This can result in a heat related failure occurring at an unknown time in the life cycle of the weapon system. Poor solder joints, poor heat sinking, and components out of electrical specification are examples of such flaws. The resulting marginal operating condition is not detectable by standard electrical tests. A method for determining abnormal emitted heat density was needed to fill this requirement.

Under MMT Effort R-3075, the US Army Missile Command (MICOM) funded Hughes Aircraft jointly with the Air Force to develop and evaluate an automatic PCB infrared emission tester. The resulting inspection system is called the Automatic Infrared Test and Inspection System (AITIS). The system, illustrated below, consists of a workbench-height console having three modules, IR scanning equipment, a TV screen, and a computer terminal movable from the console. Above the console is a frame and socket for holding the test board. The system uses a TOW common module IR detector which consists of a 60 element detector cooled by a closed cycle cooler.

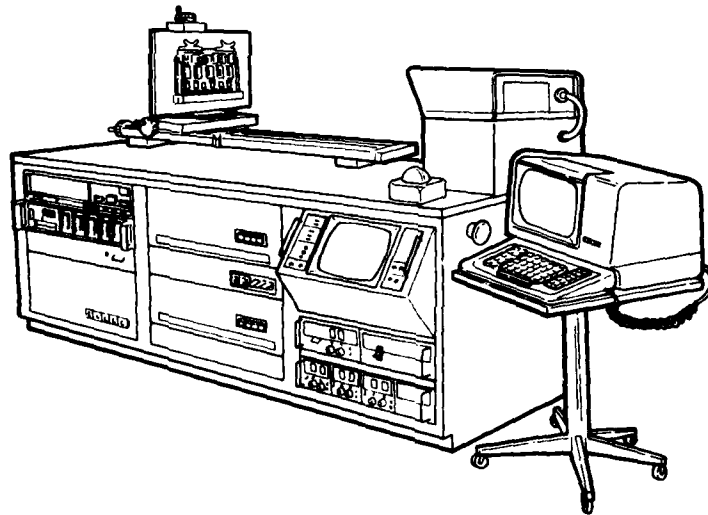

AITIS

Inspection begins with the application of power to the board for 30 to 40 seconds. The out-of-tolerance dissipation of heat energy by a faulty component, whether it is a leaking capacitor or bad resistor, is detected by the thermal imaging system as it scans the assembly. Voltage levels as low as 50 mv and power levels as low as 250 mw can produce measureable heat patterns.

The thermography system scans the board through an aperture at the front of the imager assembly. A detector receives the radiation and begins the process of converting it into a visual thermal image. The signal from the detector is processed through an enhancement and amplification system and passed through a temperature reference control, into the unit's memory. Finally, it is displayed on the integral CRT monitor.

For closer looks at a specific spot within the scanner's range, the stored image can be magnified up to four times through the unit's built-in zoom control. The imager has a freeze-frame mode enabling the retention of the image for up to 1 hour with no more than a one gray tone shift. A Polaroid camera can be attached to the screen to take an instant photograph of the displayed image.

A standard temperature profile of the PCB or hybrid is made by thermographically testing several good units. It is then stored in memory as a digitized 512 x 480 element record of all the unit-to-unit thermal variations that can occur in good units, along with tolerance information. Each unit-under-test is compared by the computer to the stored profile and tolerance information. Differences are automatically calculated and displayed on a thermogram, corresponding to areas that are colder or hotter than allowable tolerances.

AITIS permits a relatively unskilled operator to automatically test and isolate faulty areas quickly. AITIS is applicable to production lines, repair depots, repair shops, and design laboratories as a complement to ATE, a screening and testing device for reparable PCBs, a field diagnostic tool, or for detailed thermographic analysis. Suspect boards can normally be tested at a rate of over 10 per hour. It has been estimated that up to 70 percent of all PCB problems can be detected using AITIS, resulting in substantial savings of time and resources.

The AITIS is undergoing acceptance testing. Personnel training and delivery to Sacramento Air Force Base is expected in October 1984. A capability demonstration is scheduled for 11 January 1985. Hughes has taken preliminary steps to market AITIS commercially under the name Thermoscan. They have built a second unit for in-house factory use already.

Additional information is available by contacting Mr. Gordon Little, MICOM, AUTOVON 746-1489 or Commercial (205) 876-1489.

COMPUTERIZED COLOR MATCHING SYSTEM

The Department of Defense annually spends several hundred million dollars for dyed textiles. These are used in the myriad textile items as varied as combat clothing, field packs, parachutes, armored vests, formal attire, tents, tarpaulins, and vehicle covers. Up to 30 different fabrics are needed to equip a soldier for combat. There are over 500 standard fabrics in a variety of colors, composition and construction to meet all military needs.

Before a production lot is accepted, the Government tests the fabric in many ways. A visual inspection for color and shade acceptability is subjective, unlike the majority of physical or chemical tests performed which result in verifiable numerical data. This leads to as many as four serious disputes over color acceptability every month. These disputes can cause late delivery of materials needed for production and delay payment. A Government penalty for delivery of substandard material can place a severe burden on a contractor in the highly competitive industry.



Color Matching System

Under MTT Project M-6350-2431, the US Army Natick Research and Development Center (NRDC) developed and procured an expandable two-unit system to solve the subjective inspection problem. The system integrator was Applied Colorsystems, Inc. The system uses a mathematical expression of acceptability which is calculated using data relayed from a spectrophotometer. This quantitative expression allows the Government to

indicate what corrections should be made to achieve acceptability. In order to determine acceptability, a rigorous system-wide calibration procedure was developed using color tile standards supplied from Hunter Lab. Computer software was developed to control calibration and operation, to make necessary computations, to store required data, and to communicate between the master unit and remote stations.

The Computerized Color Matching System, shown in the photo, consists of a master unit located at NRDC and a single remote unit located at the Defense Personnel Support Center (DPSC). The system at NRDC consists of a Digital Equipment Corporation (DEC) PDP 11/23 with 128K of memory, a DEC VT100 video terminal, two DEC LA 120 Decwriter Hard Copy Terminals (one for use as a line printer and one as an additional tie-in to the computer), two DEC RL02 disk drives and a modem interface that connects to DPSC. The computer at DPSC is a DEC PDP 11/03 with 32K of memory, a DEC VT100 video terminal, a DEC LA120 line printer, two DEC RX02 floppy disk drives, and a modem interface to transmit data to NRDC. The main difference in the two computers is that the one at DPSC has a RT-11 single-user operating system and the one at NRDC has an RSX-11M multi-user operating system and greater memory capacity.

This system will provide the Government with an objective method of determining contractor performance. Increasing communications between the Government and contractors will result in time and money savings through the implementation of remote data stations. Three additional units have been procured with RESHAPE funding. Delivery is expected in March 1985. After acceptance testing, these units will be installed at fabric manufacturers for the duration of Army contracts.

Additional information is available by contacting Mr. Ralph Merullo, NRDC, AUTOVON 256-4899 or Commercial (617) 651-4899.

ULTRASONIC TIRE INSPECTION

Military wheeled vehicles use tires of exceptional quality to withstand the rigors of the military environment. Because of their high quality and large size, the tires are too expensive to simply discard upon tread wear out. Retreading was found to be an economical way to conserve military tires. However, this requires the tires to be inspected before and after retreading for any defects in the core of the tires. Automated commercial inspection equipment capable of examining tires in accordance with military specifications was not available.

Under MMT Effort M-6350-2445, and MACI Effort T-6052, the US Army Tank-Automotive Command (TACOM) contracted the General American Research Division of GATX Corp. to develop, build, and evaluate a prototype ultrasonic tire inspection system that acts as a tire quality monitor (TQM). The engineering prototype TQM, shown in the photo below, is a portable, computer-controlled system that uses ultrasonic pulse echoes to locate ply separations and other internal defects of both steel radial and textile tires. Echoes from defective tires are different than those from tires free of flaws allowing the system to observe these differences and find bad tires.

The system supplements visual inspection. It is not meant to detect localized defects, such as nail holes or sidewall damage, which a tire inspector can see. It looks inside the tire and sees defects that a tire inspector cannot see, and provides an assessment of the tire's overall condition.

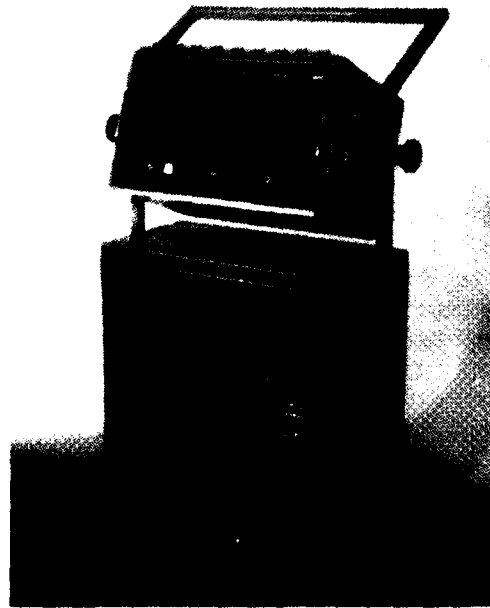

Tire Quality Monitor

The TQM consists of a hand-held scanning probe that transmits and receives ultrasonic signals, a temperature probe, and a unit comprising a computer, a control panel and an alphanumeric display. The inspection procedure begins with the calibration of the system for the type of tire to be inspected by pressing the appropriate switches on the control panel. A film of polyvinyl-alcohol solution is applied to about 25% of the tread surface. This liquid enhances the transmission of ultrasonic signals between the scanning probe and the tire.

Because changes in tire temperature affect the speed of sound and the amount of attenuation of the ultrasonic signal in the tire, the temperature must be measured so that the readings can be compensated. A temperature probe is inserted into the tire at the inspection site. After allowing about four seconds for the equipment to take a temperature reading, the operator stores the reading in the computer. He then holds the scanning probe against a flat portion of the wet tread to begin the test procedure. During the test, ultrasonic signals from the scanning probe enter the tire and echo back to the probe. When enough signals have been obtained for the computer to make an evaluation, a signal appears on the display, and the operator stores the data in the computer. The operator then repeats the process at four other points along the tread test area.

When five readings have been stored, the operator requests a tire analysis. The computer compares the stored data with signal parameters recorded earlier from known good and bad tires. Within a few seconds after the analysis begins, the test results are displayed and an accept/reject light is illuminated.

The engineering prototype TQM is now in operation at the Ober-Ramstadt Army Depot in Germany, the only US facility in Germany that retreads military tires. A second prototype underwent tests early in 1983 at the Tooele Army Depot, UT. The inspection of 1,525 tires, both prior to and after retreading, has provided the conclusion that TQM inspection can preferentially reject poor quality candidate retread tires and that the average TQM indications of good and poor quality tire casings are significantly different with a confidence level of 97 percent.

GATX Corp. is under contract to build an improved version of the tester that will be designed to further simplify the calibration procedure for the operator. Environmental chamber testing of the advanced system is scheduled to start at Tooele in 4Q 1984 and should take about 4 months to complete. If the upcoming tests are successful, the next step will be to get Army approval to purchase the tester for general use. The expected procurement is about 100 TQM units.

The price tag for the system would be about \$12,000. According to an economic analysis, however, the money saved by reducing the number of defective retreads would equal the purchase cost after inspection of approximately the first 1,000 tires.

Additional information is available by contacting LT. Young Chae, TACOM, AUTOVON 786-6474 or Commercial (313) 574-6474.

WELD ARC SPECTRUM ANALYZER

During the welding process, changes in arc voltage, travel speed, heat input, and shielding gas content can cause defects which seriously decrease the service life of the welded joint. Locating and repairing these defects can be a major production cost. The detection of weld flaws as they occur could be incorporated into a system to map the quality of the welds on a component. The automatic location of weld flaws would significantly increase the weld testing yield, eliminate the time spent searching for flaws, and reduce costs.

During the past decade, the US Army Construction Engineering Research Laboratory (CERL) has been developing a real-time weld quality monitor (WQM) to detect flaws as they occur. CERL developed a low-resolution electro-optical arc spectrum analyzer. Photographic filters were used to divide the arc spectrum into five bands spanning the range from 400 to 1000 nanometers. With this device, it was possible to separate and quantify segments of the weld spectrum and correlate the energy distribution among these segments to specific weld parameters. The results indicate that it may be possible to classify weld flaws based upon the energy distribution in the arc spectrum.

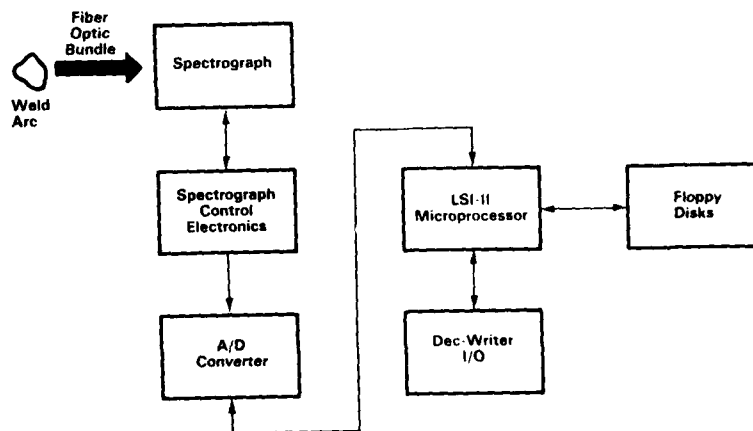

Weld Quality Monitor

To supplement and extend this work, a high-resolution microprocessor-controlled WQM was developed. A block diagram is shown above. In the electro-optic part of the WQM, the optical radiation emitted by the weld arc in the region from 300 to 1200 nanometers is collected by a fiber optic bundle. The bundle, which is designed to withstand the higher temperatures surrounding the weld arc, is terminated at the spectrograph

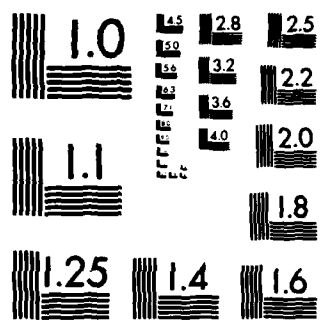

MICROCOPY RESOLUTION TEST CHART
NATIONAL BUREAU OF STANDARDS-1963-A

entrance slit. The light passing through the slit is reflected by a mirror to a concave holographic grating which images the spectral range from 300 to 1200 nanometers onto a 1024 element linear photodiode array. The spectrograph resolution is on the order of 1 nanometer.

In the process data part of the WQM, data is acquired by an analog-to-digital converter that is controlled by Direct Memory Access electronics. The user interface, data transfer and control are maintained by either Fortran IV or the DEC machine language, Macro-11. The device initialization, synchronization, and data acquisition programs are written in Macro-11. The user interface programs that are necessary for data specification and display are written in Fortran IV. The spectral data along with measurements of the arc voltage, current, and travel speed can be processed or stored on floppy disks for later analysis. This data can be compared with preprogrammed tolerance values to determine faults.

To illustrate the capabilities of the WQM, two bead-on-plate test experiments using the shielded metal arc welding process (Argon shielding gas, carbon steel base metal, and EZOS-1 electrodes) were performed. In the first experiment, the argon shielding gas was interrupted during the welding process and the resultant changes in the arc spectrum, voltage, and current were observed. Complete or partial loss of shielding gas can cause flaws such as porosity and slag in the weld. Upon removal of the shielding gas, the arc length decreases and the mode of metal transfer changes from spray to globular. The large globules of weld metal cause some shorting of the arc which in turn causes instability of the current and voltage.

The wavelength range from 400 to 1000 nm corresponds to the spectral region from the near ultraviolet to the near infrared and includes the visible region of the spectrum. The spectral lines with wavelengths longer than 700 nm are due to excitation of the argon shielding gas by the arc. When the shielding gas is removed, these spectral lines disappear. Repeated tests show an unambiguous correlation between the loss of the long wavelength lines and the loss of the argon shielding gas.

The second experiment was designed to determine the correlation between heat input and the arc spectrum. In all cases, the general trend is for the spectral energy to decrease as the heat input increases. However, the decrease seems to be more pronounced and more systematic for the wavelength region between 400 to 700 nanometers. Because different regions of the spectrum behave differently as the heat input is changed, it may be possible to compute the heat input directly from the spectral data.

The WQM was designed for Army use in tanks and weapon systems production, and for the construction of lock gates on dams. Private industry may use the field portable WQM at the site of any construction project requiring high quality welds such as those needed for underground pipelines and nuclear reactors.

The Department of the Army granted exclusive licensing rights on its WQM to National Standard Corporation of Niles, MI, in May 1984. In return for the exclusive rights to manufacture the device, National Standard will pay a royalty to the Federal Government and participate in a joint program to further develop the WQM.

For additional information, contact F. Kearney, or R. Weber at USA-CERL, FTS 958-7211 or Commercial (217) 373-7211. The National Standard Corporation point of contact is S. Habib, Commercial (616) 683-8100.

1100 CONTINUOUS FLOW PROCESS

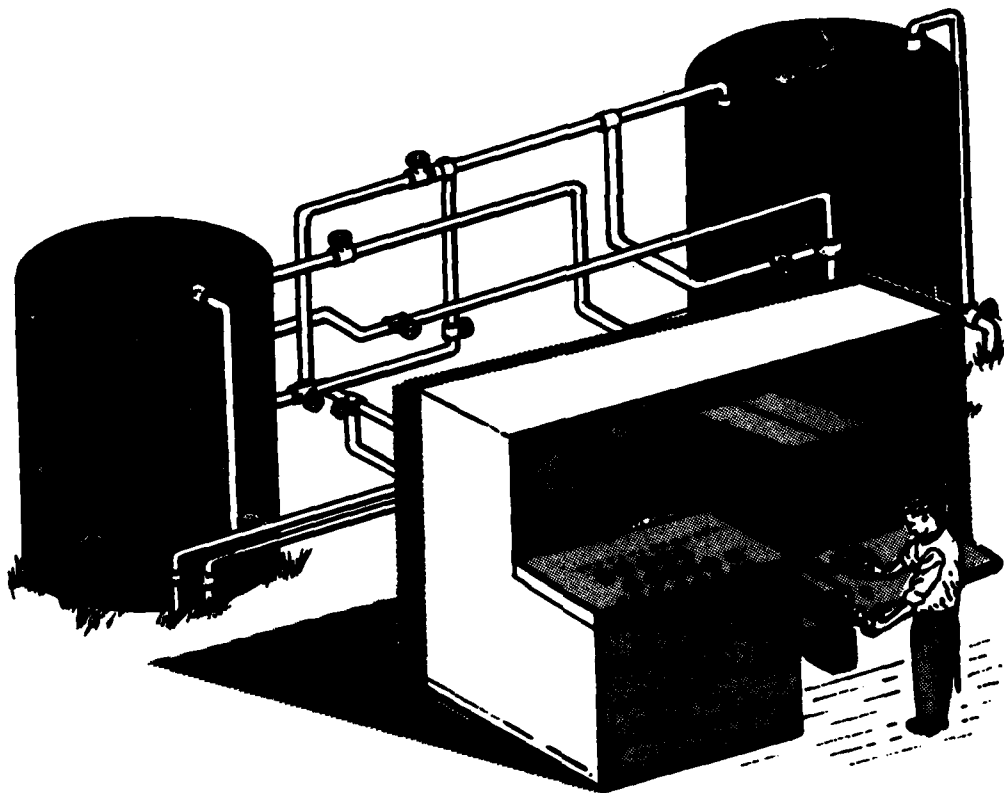

This area addresses the range of manufacturing processes that, for the most part, are continuous with minimum human interaction. By their nature, these processes tend to be systems unto themselves, interfacing with more discrete or batch processes. Continuous flow processes need real time control and therefore implement distributed processing with high data rate communications. These types of processes are most often found in ammunition plants in the Army.

CONTINUOUS MULTI-BASE PROPELLANT PRODUCTION

Batch manufacturing of multi-base propellant is labor intensive, hazardous to operators, requires expansive land areas, and requires multiple manual handling and transportation operations. To produce 3 million pounds of propellant requires approximately 400,000 manual handling and vehicular transportation steps. Since the 1940s, many continuous flow processing techniques have been developed. It was believed that many of these processes could be applied to the manufacture of cannon propellants. The end result would be a product produced at a lower cost and a safer, more modern and efficient manufacturing facility.

The US Army Production Base Modernization Agency (PBMA) is currently providing an advanced manufacturing facility for the continuous automated production of solvent processed multi-base cannon propellants. The continuous flow process is illustrated below. The facility construction was executed on PIF Project 5 80 2875 entitled "Continuous Automated Multi-Base Line (CAMBL) Hybrid" by the US Army Corps of Engineers at the Radford Army Ammunition Plant (RAAP), Radford, Virginia. The automated production facility, operated for the Army by Hercules, Inc., was designed on the basis of prototype equipment developed earlier by Hercules under MMT Effort 5-4202.

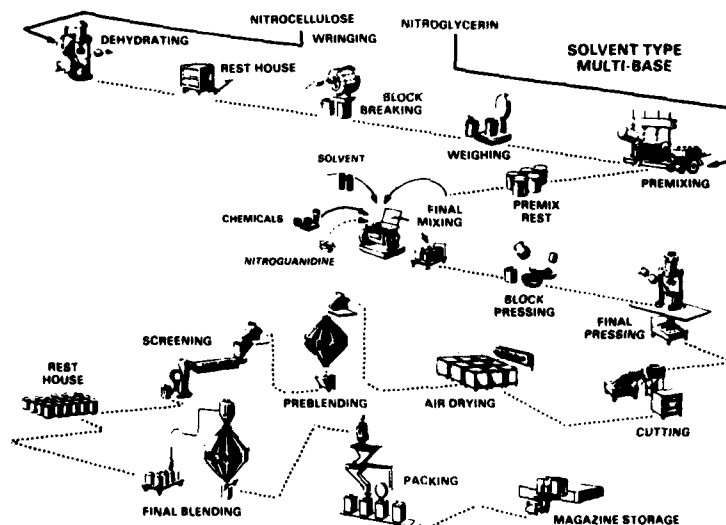

Propellant Production Flow

The objective of the MMT effort was to establish information that would provide for the design, procurement, and evaluation of an automated

continuous process. A hazards analysis and literature search were undertaken, resulting in the identification of equipment that could perform, in a continuous mode, those functions that were being performed in a batch mode.

Specifically, there were five items of equipment that had a promising potential for application in a continuous line. A thermal dehydration unit would replace a basket centrifuge and a ram press which were used to dehydrate nitrocellulose. A continuous ribbon blender was selected to replace the batch mixing kettles. A continuous co-rotating twin screw agitator mixer was selected for the final colloidizing and mixing of propellant formulations. A screw extender would replace the hydraulically driven ram press that extrudes the green propellant through graining dies to form multiple strands. The cutting of the strands would be performed by a roll cutter instead of the hand fed cutting machines.

A bench scale evaluation program was established to determine the performance characteristics of this equipment. Then, a pilot line using full scale equipment was constructed. Full scale equipment was used to avoid any future scale-up problems. Initially, the individual units of equipment were operated separately. Then the units were connected with conveyors to evaluate the system in a continuous mode. The pilot line was successfully demonstrated and it became the basis for the facility design and equipment specifications.

With the CAMBL/Hybrid facility, manufacture of multi-base propellant is automated from thermal dehydration of the nitrocellulose slurry to traying of the granular propellant product. The distributed architecture control system consists of an array of satellite processors located at each production building. The satellite processors communicate to a host computer over a local area network which is configured to resemble the spokes in a wheel, with a host processor as the hub. Each satellite processor is apportioned specific tasks of the total control requirement and each carries out its tasks with minimum burden to the host processor.

At the time of control system selection, only the Foxboro Company had developed and installed in operating factories a truly distributed control system which provided the task division capabilities of distributed architecture while providing mainframe capabilities by a host computer which could be located several thousand feet from its satellites. In order to support the extremely high data transfer rate requirement between satellites and host, the Foxboro system utilizes serial data communications providing one million bit-per-second data rates with four level redundancy capability within the local area network. The Foxboro SPECTRUM system provides the required process responsiveness while affording substantial background program development and report generation facilities. A Foxboro Spectrum control system was installed consisting of 4 FOX 1A computers, 9 Videospec units, numerous distributed control elements - unit control modules (UCM), and numerous Microspec separate universal input/output (UIO) modules. The FOX 1A computers provide supervisory setpoint information to UIO modules which control a line located at each manufacturing building.

Each UCM is a microprocessor which may be programmed to perform specific control algorithms, called blocks, with the further capability to do complex block cascading to suit a particular control requirement. In the CAMBL implementation, the UCM control schemes range from simple, single block schemes to multi-level schemes involving analog blocks linked to blocks that perform logical gating functions.

Overlaying the unit level control schemes performed by UCM's is the supervisory level of control. As the designation suggests, supervisory level control manages and provides input to the unit level control schemes. Supervisory level control is performed by a software subsystem within the host processor which, like the UCM schemes, is made up of control blocks. The supervisory control blocks provide input to and receive information from the unit level control blocks resulting in a highly efficient continuous control subsystem.

Process sequential control manages the startup, shutdown and control system response to process emergencies. With the exception of local interlocking which is handled by programmable controllers, virtually all process sequencing is performed by a host-resident software subsystem referred to as BATCH. The BATCH logic subsystem is further divided into two functional systems designated normal logic and service logic. Normal logic manages the startup and normal shutdown activities associated with normal process operation. Service logic, which is process-responsive, handles abnormal process events such as fire detection and operator requests for an aborted startup or an emergency shutdown.

The continuous automated multi-base line will be capable of producing both double-base cannon propellant which contain nitrocellulose and nitroglycerin, and triple-base formulations of nitrocellulose, nitroglycerin, and nitroguanidine. The MMT pilot line demonstration produced a triple-base propellant, M30, and its performance was evaluated ballistically in the M490, 105mm tank round. Being successful, work on the pilot line was continued to broaden the knowledge of processing parameters. An additional triple-base, M30A1, pilot lot was successfully tested ballistically in the M203, 155mm propelling charge. Smaller batches of double-base propellant were also successfully produced for laboratory evaluation.

The CAMBL/Hybrid process will manufacture propellant for the following weapon systems: The M188 Prop Charge for the 8 inch, the XM815 Heat Cartridge for the 105mm, the M833 APFSDS Cartridge for the 105mm and the M203 Prop Charge for the 155mm. The CAMBL/Hybrid process actually reduces personnel requirements from 540 to 240 for the manufacture of multi-base propellant and reduces operating costs from \$.40 - \$.50 per pound of propellant. In addition, the automated facility provides an expansion of the production base with an increase in production capacity of 2.4 million pounds per month. Facility completion is expected in 2 Q 85.

The point of contact for this project is Mr. Olin Colitti, PBMA, AUTOVON 880-2941, Commercial (201) 724-2941.

CONTINUOUS PROCESS CONTROL FEEDBACK

The technique for the manufacture of TNT is the continuous process system illustrated below which is in operation at several Army ammunition plants. This system operates on a continuous basis from the initial nitration stage, through the dinitration and trinitration stages, and finally through the purification step. Process control operations consist of chemical laboratory tests on samples taken from different stages of the process. The tests are performed in a laboratory adjacent to the manufacturing lines. Since no real-time process control testing or automatic feedback exists in the present systems, any corrective actions that may be necessary cannot be made until the test results are known. In a continuous system, this lapse of time between taking and analyzing a sample can allow the production of large amounts of product that do not meet specifications.

Under MMT Effort 5-4215, the US Army Armament, Munitions & Chemical Command (AMCCOM) contracted Hercules to establish in-line process control systems through utilization of real-time analysis for automatic feedback control. A major part of the effort was the evaluation of sensor instruments. The types of analysis required in TNT plants include nitric acid, sulfuric acid, nitrobody density, and composition flow rates, PH, and TNT set-points. The instrumentation must be highly reliable and operated remotely because of the hazardous and corrosive environment.

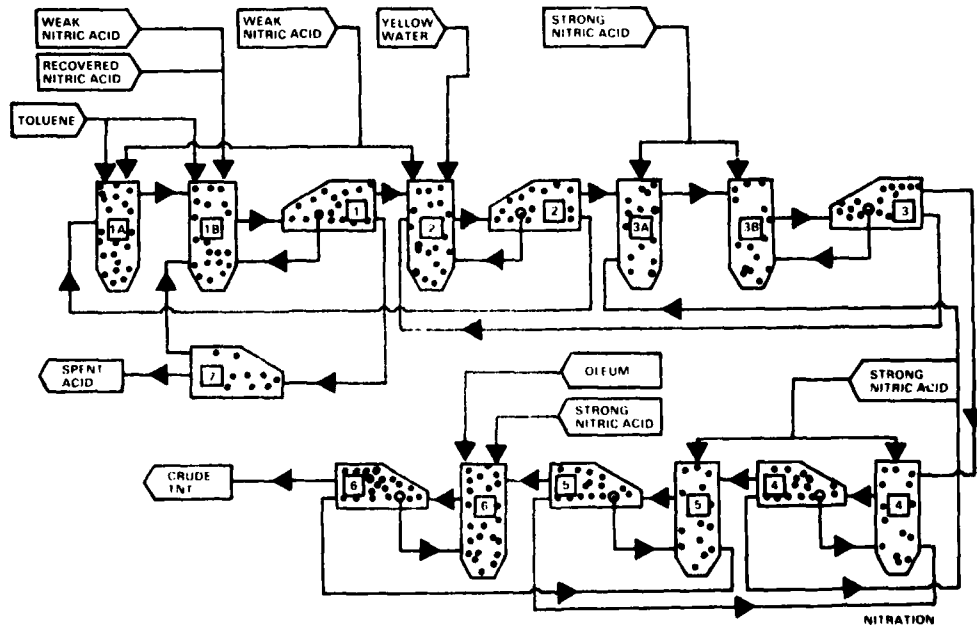

TNT Process Flow

Accurate feed rate control requires that flow rate and density be measurable and adjustable for control of mass flow rates of sulfuric and nitric acids to each vessel. Externally mounted gages on pipes were deemed to be the most desirable for production use. A Kay-Ray nuclear density gage was selected for this application. After its evaluation, it was concluded that it would be an excellent means for controlling flow rates, i.e., acid strength control. It was also determined that eight gages would be needed for adequate process control of a continuous TNT manufacturing process.

Three types of instruments were considered for measurement of process stream flow rates. Each used a different principal of measurement. One was a target type meter, the other an ultrasonic flowmeter, and the last, a magnetic flowmeter. The magnetic flowmeter was selected as the best candidate for process control. It measured flow by producing an emf that was proportional to the fluid velocity. It was durable, stable, and its accuracy had been proven acceptable in field testing.

The manufacture of TNT requires close control of sulfuric and nitric acids entering and departing each nitrator. An instrument that could analyze both sulfuric and nitric acid was needed. A complicating factor was that soluble nitro bodies were contained in these acid streams. These nitro bodies interfered with sample analyses and produced low measurements for nitric acid concentrations. An instrument suitable for on-line installation and capable of continuously monitoring the spent acid of each nitrator without interference from the nitro bodies was sought. The technique that showed promise towards meeting these requirements was liquid chromatography (LC). The LC approach was demonstrated by operating one TNT manufacturing line for a 1-week period using nitric/sulfuric data derived from an off-line LC unit.

These instruments were selected for implementation in PIF Project 5 75 5901. The benefits of the resulting continuous flow process system are: reduction of personnel exposure to hazardous environments, elimination of manual testing overhead, improvement of TNT product and processes through automatic feedback and elimination of TNT batch rework.

Additional information is available by contacting Mr. Harold Kesselman, AUTOVON 880-3239 or Commercial (201) 328-3239.

APPENDICES

APPENDIX A

INTERACTIVE GRAPHICS INVENTORY

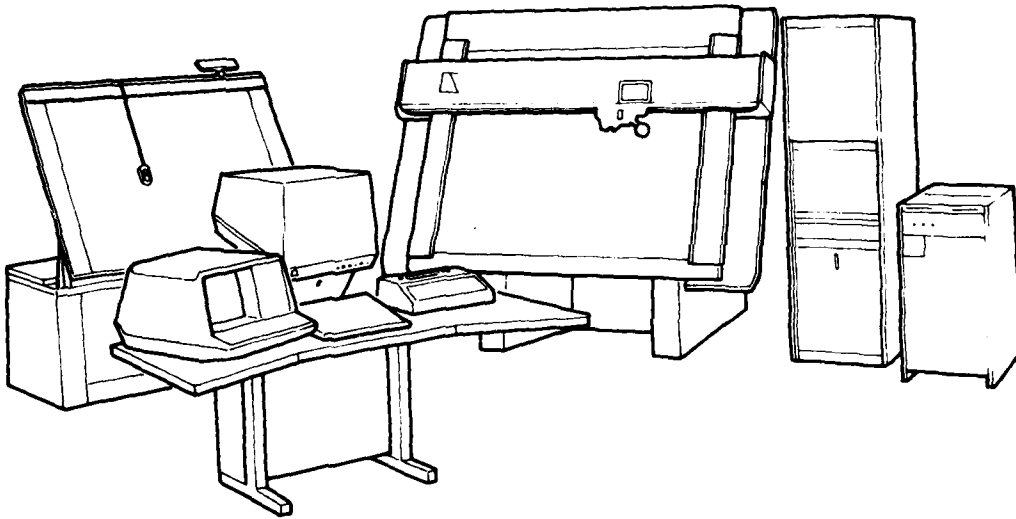

INTERACTIVE GRAPHICS INVENTORY

The Army has been acquiring interactive graphics hardware and software for many years. Each major subordinate command participates in the procurement and/or development of interactive graphics to a greater or lesser extent. At the end of any of a variety of developmental programs, the Army becomes the owner of the equipment developed on the contract. Because little control is exercised over the contractor in the selection of equipment, the equipment acquired in this way tends to be a variety of types. Also, because of the large number of programs each year, the equipment tends to be of various vintage.

The other most common way that equipment is acquired is planned procurement. In this way, equipment to be installed in an entire Army facility tends to be of the same make and vintage. This reduces the possibility of the equipment not interfacing.

In order to better determine the participation of the various Army components in utilizing interactive graphics and their resultant capabilities, the AMC CAD/CAM Steering Group performed a survey of the Army components. This survey relied on accurate voluntary input. The following is the result of that survey. As can be surmised, each Army component uses a certain type of equipment in certain application areas as dictated by its mission.

AMC EXISTING CAD/CAM GRAPHICS SYSTEMS

COMMAND/LOCATION	SUBTOTAL NUMBER OF SYSTEMS	PRINCIPLE APPLICATION AREA						VENDOR/MODEL
		DESIGN & ANALYSIS		FACILITY LAYOUT	MFG SUPPORT	INTEG CIRC	GENERAL APPL.	
		Elec	Mech					
AMCCOM - Subtotal	12		6	-	1	-	5	
ARSENALS								
Rock Island Arsenal, IL			Primary	X	X			Mfg Consult Serv
Watervliet Arsenal, NY			X				Primary	IBM*
LABS & CENTERS								
ARDC, Dover, NJ			X		Primary		X	McAuto Unigraphics
ARDC, Dover, NJ			Primary					Computervision
ARDC, Dover, NJ			X		X		Primary	Control Data*
ARDC, Dover, NJ							Primary	EA1 3200
ARDC, BWL, Watervliet			Primary					Gerber
ARDC, BWL, Watervliet			Primary					Lundy
ARDC, BWL, Watervliet			Primary		X		X	Draper Labs/IBM*
CRDC, Aberdeen, MD			Primary		X		X	Info. Displays
CRDC, Aberdeen, MD			X				Primary	UNIVAC*
HQ, Rock Island, IL	1		X		X		Primary	PRIME

Legend

- * - Embedded as part of a Main Frame System capability.
- Primary - Indicates that this application area is the dominant usage for the system.
- X - Indicates that this application area is an additional usage for the system.
- Integers - Indicates the number of systems, by primary application area, for an organization.

AMXIB-MT 14 Mar 84

AMC EXISTING CAD/CAM GRAPHICS SYSTEMS

COMMAND/LOCATION	SUBTOTAL NUMBER OF SYSTEMS	PRINCIPLE APPLICATION AREA						VENDOR/MODEL
		DESIGN & ANALYSIS		FACILITY LAYOUT	MFG SUPPORT	INTEG CIRC	GENERAL APPL.	
		Elec	Mech					
AVSCOM - Subtotal	1						1	
HQ, St. Louis, MO Engine Plant			X				Primary	IBM*
Stratford, CT **			Primary	X	X		X	McAuto Unigraphics
Stratford, CT **				X	Primary		X	McAuto Unigraphics
CECOM - Subtotal	9	1					2	
Ft. Monmouth, NJ		Primary						Info. Displays
Ft. Monmouth, NJ							Primary	Gerber
Ft. Monmouth, NJ		X				X	Primary	IBM*
DESCOM - Subtotal	9			2	6		1	
Anniston Army Depot, AL			X		Primary			Applicon 895
Corpus Christi AD, TX			X		Primary			McAuto Unigraphics
Corpus Christi AD, TX			X	Primary				McAuto Unigraphics or GA SOC-16/65
Letterkenny AD, PA		X	X	X	Primary	X		Applicon 895
Letterkenny AD,		X	X	X	X		Primary	Applicon 895
Red River AD, TX		X	X	X	Primary			Gerber
Sacramento AD, CA		X	X	X				Gerber
Sharpe AD, CA			X					HP-A 600
Tobyhanna AD, PA		X	X	X	Primary			Applicon 895
Tooele AD, UT		X	X	X	Primary			Applicon 895
Tooele AD, UT		X	X	Primary	X			Applicon 895

Legend

- * - Embedded as part of a Main Frame System capability.
- Primary - Indicates that this application area is the dominant usage for the system.
- X - Indicates that this application area is an additional usage for the system.
- Integers - Indicates the number of systems, by primary application area, for an organization.
- ** - Indicates that this system in a GOCO facility is contractor owned, and is listed for information only, not included in subtotals.

AMC EXISTING CAD/CAM GRAPHICS SYSTEMS

COMMAND/LOCATION	SUBTOTAL NUMBER OF SYSTEMS	PRINCIPLE APPLICATION AREA						VENDOR/MODEL
		DESIGN & ANALYSIS		FACILITY LAYOUT	MFG SUPPORT	INTEG CIRC	GENERAL APPL.	
		Elec	Mech					
ERADCOM - Subtotal	14	5			1	5	3	
ET&DL - Subtotal	6	2				4		
ET&DL, Ft. Monmouth, NJ		Primary						Interdata 8-32
ET&DL, " "		Primary						HP 9830
ET&DL, " "		X				Primary		Prime 550 (11)
ET&DL, " "		X				Primary		Applicon 860
ET&DL, " "		X				Primary		Applicon 870
ET&DL, " "		X				Primary		Avera 1000
HDL - Subtotal	8	3			1	1	3	
HDL, Adelphi, MD		X					Primary	IBM 370/168*
HDL, " "		Primary					X	DEC VAX 11/780
HDL, " "		X			Primary			Computervision
HDL, " "		Primary			X	X		Computervision
HDL, " "		Primary			X	X		Computervision
HDL, " "						Primary	Primary	PRIME 400 (2)
HDL, " "							Primary	HP100
HDL, " "							Primary	Hewlett Packard (HP)
MICOM - Subtotal	3	2					1	
HQ, Huntsville, AL		Primary					X	Intergraph
HQ, Huntsville, AL		Primary					X	Intergraph
HQ, Huntsville, AL		X					Primary	CDC* Cyber 170/760
TACOM - Subtotal	3		2		1			
HQ, Warren, MI			Primary				X	Computervision
HQ, Warren, MI			Primary				X	PRIME 850
Tank Plants								
Lima Ohio**			X		Primary			McAuto Unigraphics

Legend

- * - Embedded as part of a Main Frame System capability.
- Primary - Indicates that this application area is the dominant usage for the system.
- X - Indicates that this application area is an additional usage for the system.
- Integers - Indicates the number of systems, by primary application area, for an organization.
- ** - Indicates that this system in a GOCO facility is contractor owned and is listed for information only, not included in subtotals.

AMC EXISTING CAD/CAM GRAPHICS SYSTEMS

COMMAND/LOCATION	SUBTOTAL NUMBER OF SYSTEMS	PRINCIPLE APPLICATION AREA						VENDOR/MODEL
		DESIGN & ANALYSIS		FACILITY LAYOUT	MFG SUPPORT	INTEG CIRC	GENERAL APPL.	
		Elec	Mech					
TROSCOM - Subtotal	3				1		2	
BRDC, Ft. Belvoir, VA							Primary	IBM*
NRDC, Natick, MA			X		X		Primary	UNIVAC*
NRDC, " "					Primary			HP (PICOM)
HQ, AMC - Subtotal	3		1	1			1	
ARDC, BRL, Aberdeen, MD			Primary					Digital Equip.
ARDC, BRL, Aberdeen, MD			X				Primary	Control Data*
I&SA, Rock Island, IL				Primary				Intergraph
AMC Subtotals Existing								
AMCCOM	12	-	6	-	1	-	5	
AVSCOM	1	-	-	-	-	-	1	
CECOM	3	1	-	-	-	-	2	
DESCOM	9	-	-	2	6	-	1	
ERADCOM	14	5	-	-	1	5	3	
MICOM	3	2	-	-	-	-	1	
TACOM	3	-	2	-	1	-	-	
TROSCOM	3	-	-	-	1	-	2	
HQ, AMC	3	-	1	1	-	-	1	
TOTAL - AMC Existing	51	8	9	3	10	5	16	

VENDOR SUMMARY
 3 - Main Frame vendors
 1 - Main Frame system
 14 - small computer based vendors

Legend

- * - Embedded as part of a Main Frame System capability.
- Primary - Indicates that this application area is the dominant usage for the system.
- X - Indicates that this application area is an additional usage for the system.
- Integers - Indicates the number of systems, by primary application area, for an organization.

APPENDIX B

NUMERICAL CONTROL TOOL INVENTORY

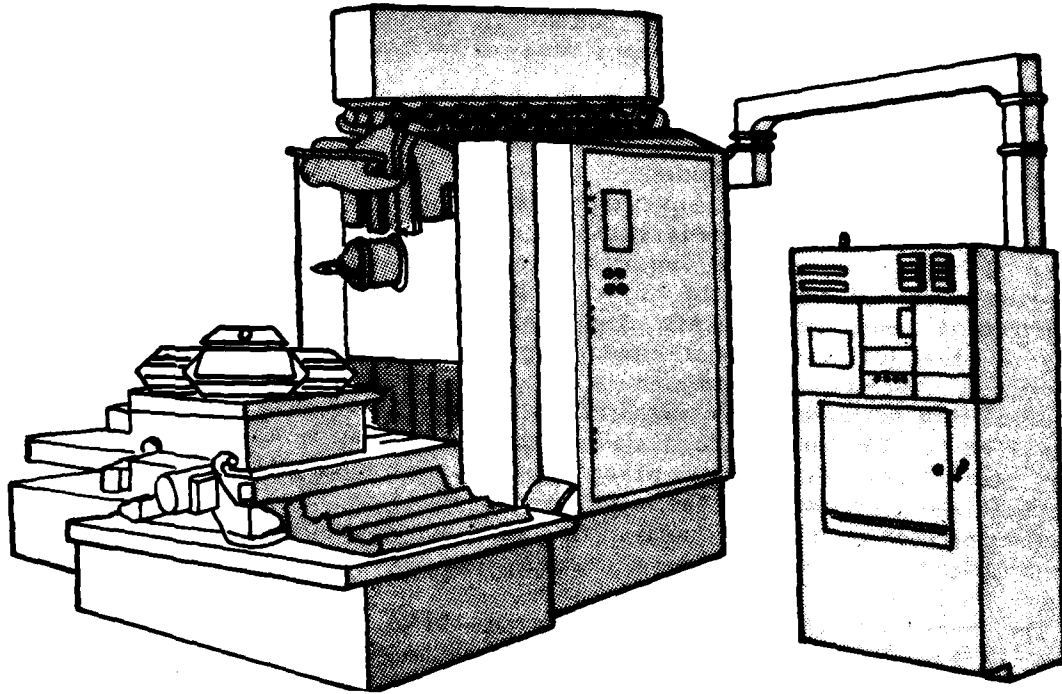

NUMERICAL CONTROL (NC)

Numerical control (NC) is available in eight classes of metalworking equipment owned by the Army. These classes are: boring, drilling, lathes, milling, machining centers, punching, grinding, and bending/forming. The Army inventory of this equipment is shown in Figure 1. Boring machines, lathes, and machining centers make up 78.2 percent of the inventory, or 686 items. Punching, grinding and bending/forming machines represent only 2.7 percent of the inventory, or 23 items.

Numerically controlled machines make a significant contribution to the production capacity of the industrial base and represent a sizeable investment. The numerical control inventory of the Army consists of 877 items with an acquisition cost of \$216,334,244. Only one item is not controlled by AMC. The distribution of the NC inventory is shown in Figure 2. Government-owned/Government-operated (GOGO) facilities control 35 percent, or 306 items. Of these, 6 percent or 53 items are subject to intermittent use, but remain in place in support of the currently assigned mission. Government-owned/contractor-operated (GOCO) facilities control 18 percent, or 157 items. Also, contractor-owned/contracted operated (COCO) facilities control 40 percent, or 355 items which are classified as Government furnished equipment. The remaining 7 percent, or 59 items, are assigned to plant equipment packages (PEPs) for use in mobilization production. The significant increase in the number of PEP items resulted from items still in use but assigned to PEPs through status code 1B.

The trend of the inventory of numerically controlled equipment is shown in Figure 3. An increasing trend characterizes the inventory, especially since 1978. The disproportionate increase in acquisition cost shown in 1978 is attributable to the addition of the rotary forge at Watervliet Arsenal at a cost of \$6,749,185. The average cost of numerical control equipment has continued to increase at a rapid rate to \$246,675.

The source of the data for numerical control equipment is the DIPEC SP-50 Report as of 27 Jan 84.

NUMERICAL CONTROL INVENTORY BY CLASS

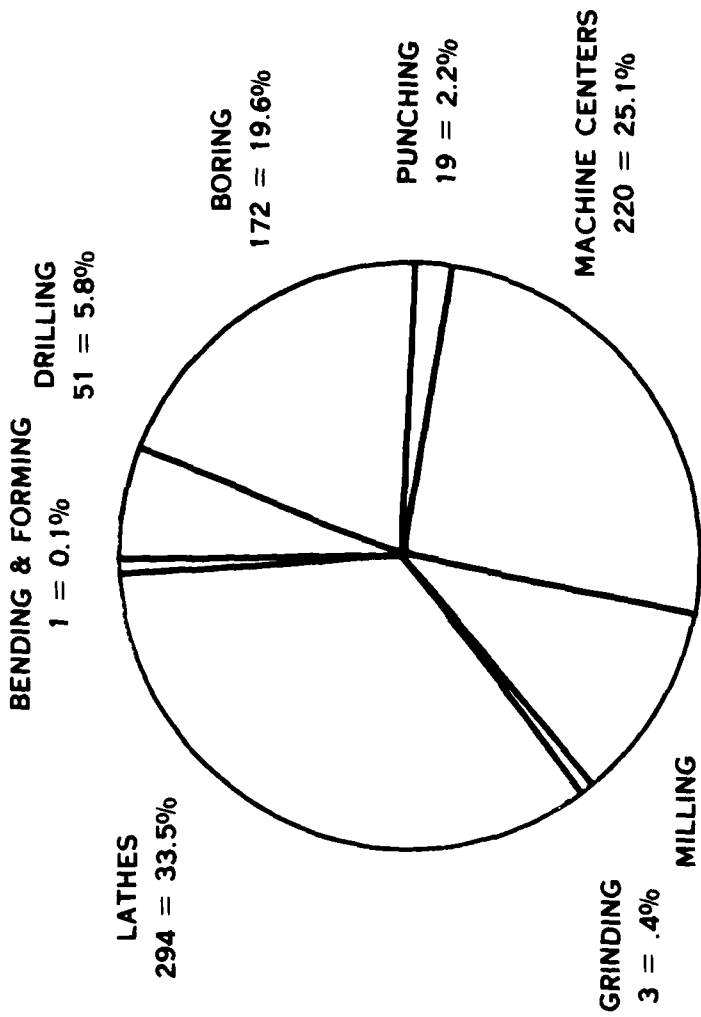

	BORING (3411)	DRILLING (3413)	LATHES (3416)	MILLING (3417)	MACHINING CENTERS (3408)	PUNCHING (3445)	GRINDING (3415)	BENDING & FORMING MACHINE	TOTAL
ACTIVE	152	39	59	97	201	15	3	1	767
INACTIVE	13	5	18	11	12	0	0	0	59
INT. USE (3H)	7	7	17	9	7	4	0	0	51
TOTALS	<u>172</u>	<u>51</u>	<u>294</u>	<u>117</u>	<u>220</u>	<u>19</u>	<u>3</u>	<u>1</u>	<u>877</u>

FIGURE 1

NUMERICAL CONTROL INVENTORY QUANTITY AND USE

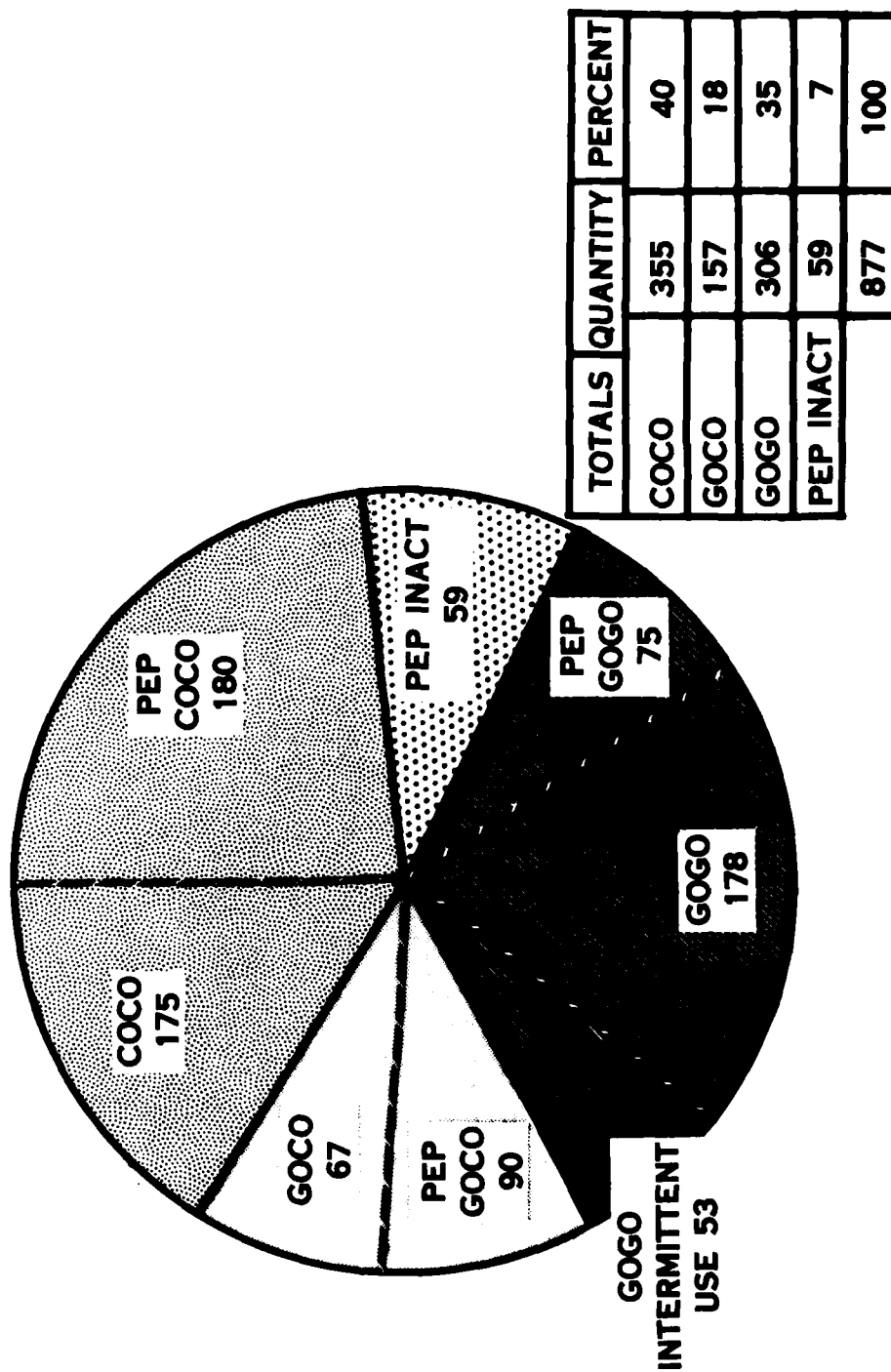

FIGURE 2

INVENTORY TRENDS NUMERICAL CONTROL EQUIPMENT

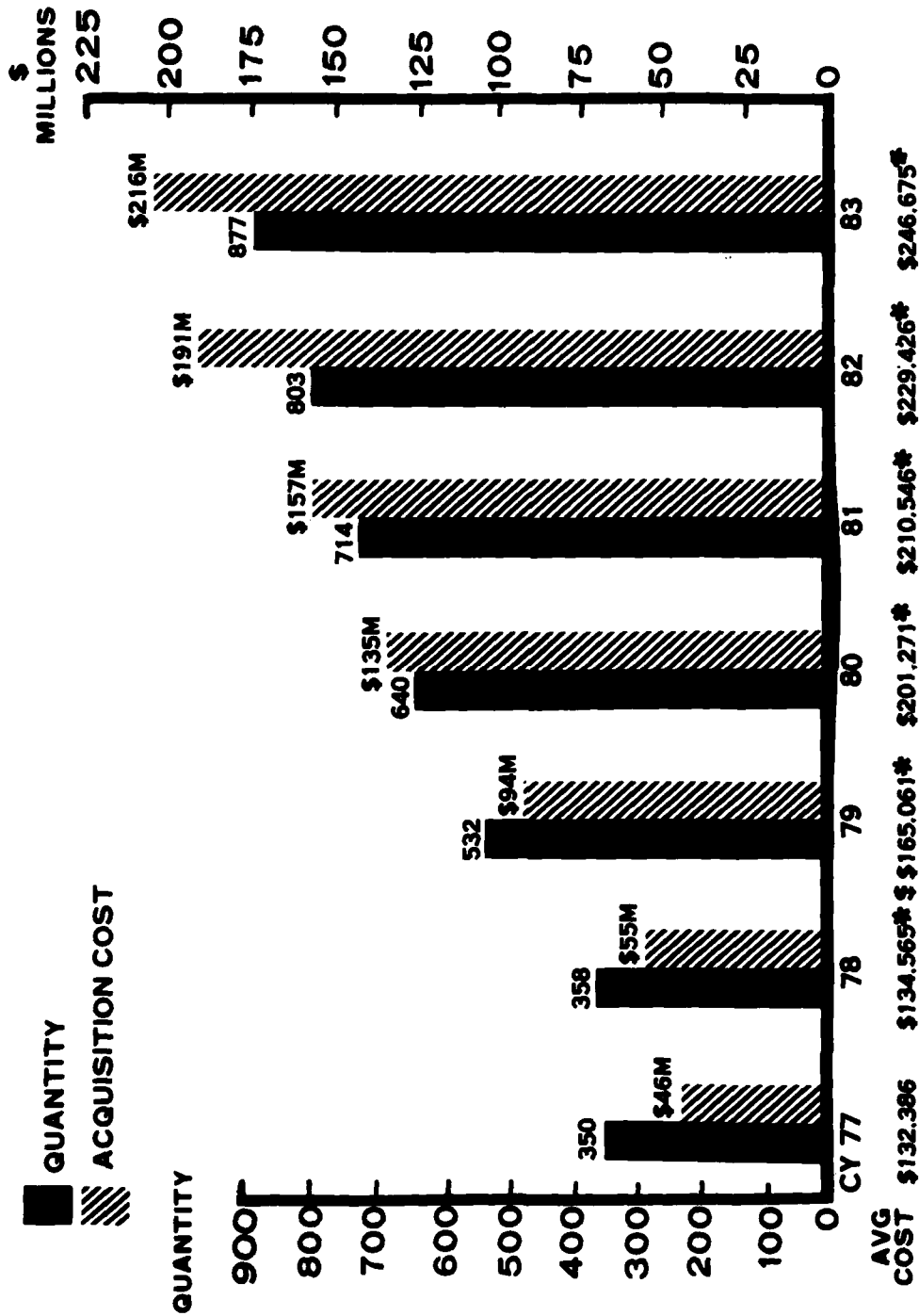
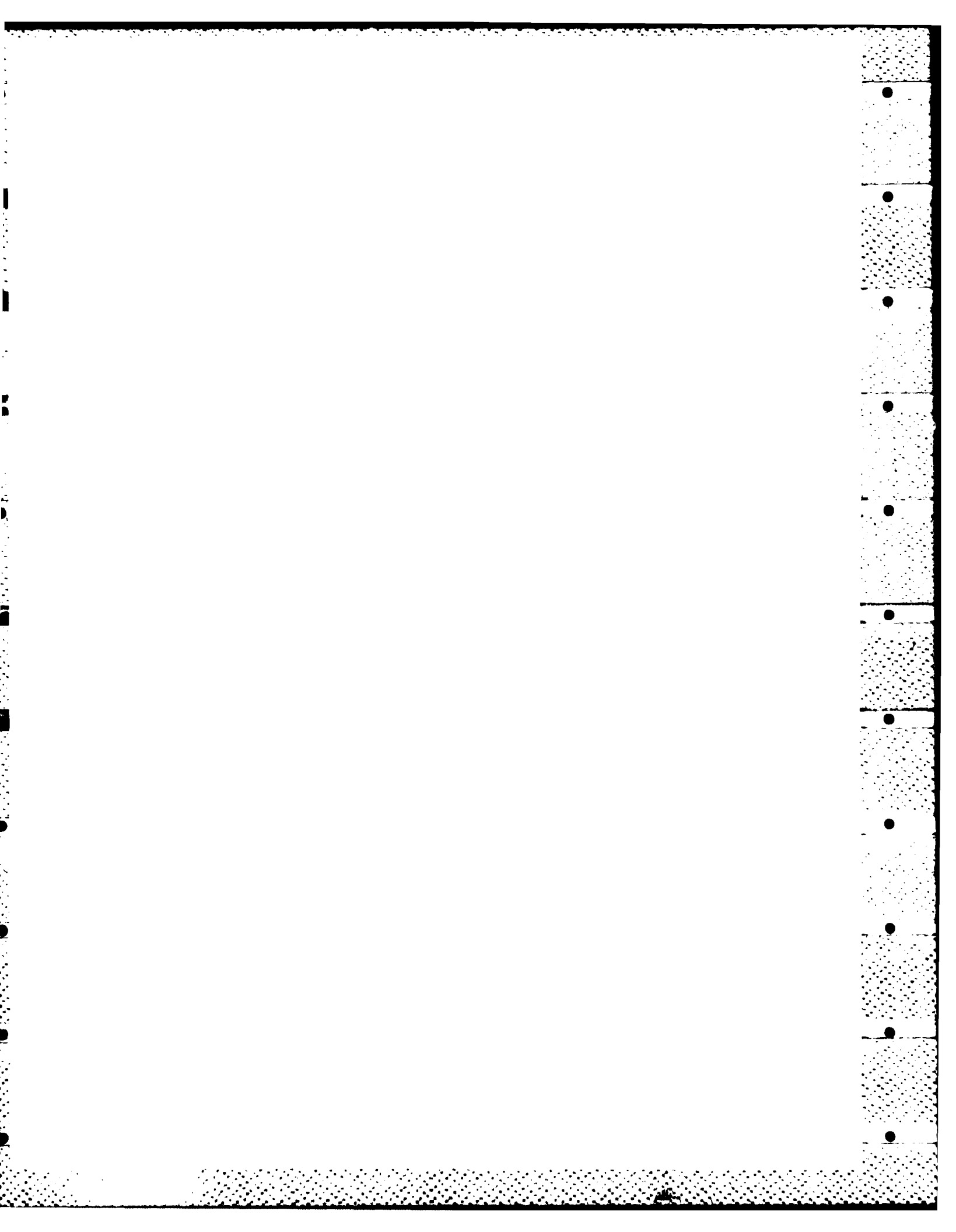
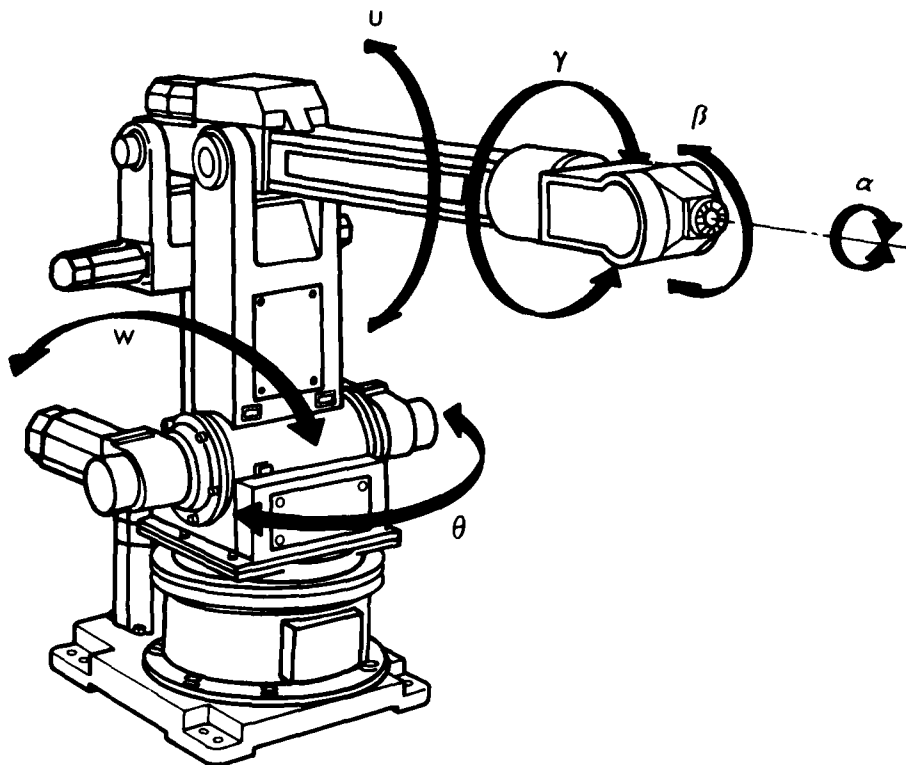

FIGURE 3



APPENDIX C

ROBOTICS INVENTORY



ROBOTICS INVENTORY

In the same manner as the interactive graphics equipment, the Army has been acquiring a variety of robots and ancillary equipment. These robotic systems were also the subject of a CAD/CAM Steering Group survey. The results of this survey are contained in the following two figures.

Figure 1 shows the inventory by area of emphasis. This shows a planned increase in the number of applications in each area except welding. Especially interesting is the large increase of spraying and painting robotics. This could be associated with the US Army Depot System Command initiative in the shelter refinishing area.

Figure 2 shows the costs of the same systems by area of emphasis. As stated before, planned increases in most areas are apparent but the significance of the past and planned costs for an individual area cannot be assessed because of unknown and uncompensated parameters. The prior applications and active technology efforts tend to cover all of the areas fairly well but the planned applications and technology efforts show a marked increase in interest in the following areas: spraying and painting, load and unload, and assembly/disassembly.

SUMMARY OF ARMY ROBOTS BY AREA OF EMPHASIS FOR ROBOTICS APPLICATIONS AND TECHNOLOGY

STATUS	AREA OF EMPHASIS							TOTALS
	SPRAYING AND PAINTING	LOAD AND UNLOAD	ASSEMBLY / DISASSEMBLY	FABRICATION	INSPECTION	MATERIAL HANDLING	WELDING	
PRIOR APPLICATIONS (FY72-83)	3	19	3	0	0	17	0	42
PLANNED APPLICATIONS (FY84-86)	24	2	5	1	1	3	0	36
ACTIVE TECHNOLOGY EFFORTS (FY80-83)	2	0	2	1	1	2	2	10
PLANNED TECHNOLOGY EFFORTS (FY84-85)	2	1	4	0	0	0	2	9

FIGURE 1

SUMMARY OF ARMY ROBOT SYSTEM COSTS MILLIONS OF DOLLARS

BY AREA OF EMPHASIS FOR ROBOTICS APPLICATIONS AND TECHNOLOGY

STATUS	AREA OF EMPHASIS										TOTALS	
	SPRAYING AND PAINTING	LOAD AND UNLOAD	ASSEMBLY/DISASSEMBLY	FABRICATION	INSPECTION	MATERIAL HANDLING	WELDING					
PRIOR APPLICATIONS (FY72-83)	0.2	1.6	0.2	0	0	1.8	0	0	0	3.8		
PLANNED APPLICATIONS (FY84-86)	3.0	0.2	1.0	0.2	0.2	0.7	0	0	0	5.3		
ACTIVE TECHNOLOGY EFFORTS (FY80-83)	0.6	0	1.2	0.4	0.7	0.6	1.5	5.0				
PLANNED TECHNOLOGY EFFORTS (FY84-85)	0.7	0.7	4.0	0	0	0	1.0	6.4				

C4

FIGURE 2

NOV 83

APPENDIX D
CAD/CAM STEERING GROUP MEMBERS

ARMY MATERIEL COMMAND
CAD/CAM STEERING GROUP MEMBERS ¹

AMC

US Army Materiel Command

ATTN: AMCPP-IF ³

AMCIM-IP/Ms. Jessie M. Herr

AV: 284-8952

AMCIM-IP/Mr. Daniel Epps (Alternate)

AV: 284-8954

AMCMT-S/Mr. John Holvoet

AV: 284-9828

AMCMT-P/Mr. Jerry Gibson

AV: 284-8053/8054

5001 Eisenhower Avenue

C: (202) 274-xxxx ²

Alexandria, VA 22333

IBEA

US Army Industrial Base Engineering Activity

ATTN: AMXIB-MT/Mr. Steve McGlone (Chairman)

AV: 793-6167

AMXIB-PE/Mr. James DeWoody

AV: 793-5617

AMXIB-PE/Mr. Rod White (Alternate)

AV: 793-6226

Rock Island, IL 61299

C: (309) 794-xxxx

AVSCOM

US Army Aviation Systems Command

ATTN: AMSAV-PEC/Mr. Fred Reed (C,EL,MT)

AV: 693-3079

4300 Goodfellow Blvd.

C: (314) 263-3079

St. Louis, MO 63120

CECOM

US Army Communications Electronics Command

ATTN: AMSEL-PC-SI-I-2/Mr. James F. Kelly (EL)

AV: 992-4996/4077

Fort Monmouth, NJ 07703

C: (201) 532-4996

DESCOM

US Army Depot System Command

ATTN: AMSDS-RM-EIT/Mr. Mike Ahearn (C,MT)

AV: 238-6591

Chambersburg, PA 17201

C: (717) 263-6321

Notes:

1 - The use of a letter code in parentheses after a members name indicates membership in a Manufacturing Technology Advisory (MTAG) Committee, or AMC MMT Representative.

C - CAD/CAM Subcommittee

EL - Electronics Subcommittee

EX - Executive Committee

M - Metals Subcommittee

MT - AMC MMT Representative

2 - xxxx - The use of these letters after the commercial area code and 3-digit prefix means that the 4-digit extension used for the AUTOVON (AV) numbers can also be used for commercial phone numbers.

3 - Individual Needs To Be Assigned - Due to personnel turnover or organization realignment or other reasons another individual needs to be identified as a representative for the respective organization.

ARMY MATERIEL COMMAND
CAD/CAM STEERING GROUP MEMBERS (CONT.)

ERADCOM

US Army Electronics Research and Development Command
Harry Diamond Laboratories
ATTN: DELHD-IT-R/Mr. Robert Rosen
DELHD-IT/Mr. Harry Hill (Alternate)
2800 Powder Mill Road
Adelphi, MD 20783

AV: 290-2917
AV: 290-3124
C: (301) 394-xxxx

US Army Electronics Research and Development Command
Electronics Technology & Devices Laboratory
ATTN: DELET-IC-K/Mr. Randy Reitmeyer
Ft. Monmouth, NJ 07703

AV: 995-4018
C: 201-544-4018

MICOM

US Army Missile Command
ATTN: AMSMI-EET/Mr. Gordon Little (C,EL)
AMSMI-RLC/Mr. Richard Eppes, Jr.
Redstone Arsenal, AL 35898

AV: 746-3604
AV: 746-3524
C: (205) 876-xxxx

TACOM

US Army Tank-Automotive Command
ATTN: AMSTA-RCKM/Mr. David Force (C)
AMSTA-ICC/Mr. Chester Zack
AMSTA-ICC/Mr. John DeBolle (Alternate)
AMSTA-TDS³
Warren, MI 48090

AV: 786-5814
AV: 786-7011
AV: 786-7016
C: (313) 574-xxxx

TROSCOM

US Army Troop Support Command
ATTN: AMSTR-PLP-(2)³
4300 Goodfellow Boulevard
St. Louis, MO 63120

AV: 693-2220/2218
C: (314) 263-2220/2218

US Army Troop Support Command
Belvoir Research and Development Center
ATTN: STRBD-DE³
Fort Belvoir, VA 22060

AV: 354-5371
C: (703) 664-5371

US Army Troop Support Command
Natick Research and Development Center
ATTN: STRNC-EML³
Natick, MA 01760

AV: 256-4899
C: (617) 651-4305

AMCCOM

US Army Armament, Munitions and Chemical Command
ATTN: AMSMC-MSE (R)/Mr. Thomas Frandsen
AMSMC-MSE (R)/Mr. Mike Swim (Alternate)
AMSMC-IRW-I (R)³
AMSMC-IRI (R)³
Rock Island, IL 61299

AV: 793-2107
AV: 793-2107
AV: 793-5590
AV: 793-4694
C: (309) 794-xxxx

ARMY MATERIEL COMMAND
CAD/CAM STEERING GROUP MEMBERS (CONT.)

AMCCOM

US Army Armament, Munitions and Chemical Command
Armament Research and Development Center
ATTN: SMCAR-TSF-D (D)/Mr. Donald O'Connor
SMCAR-TSE-I (D)/Mr. Art Reimer
Dover, NJ 07801

AV: 880-3802
AV: 880-3136
C: (201) 724-xxxx

US Army Armament, Munitions and Chemical Command
Chemical Research and Development Center
ATTN: SMCCR-SPD-E³
Aberdeen Proving Ground, MD 21010

AV: 584-3350
C: (301) 724-3350

US Army Armament, Munitions and Chemical Command
Production Base Modernization Agency
ATTN: AMSMC-PBM-TI (D)/Mr. Douglas Morlock
Dover, NJ 07801

AV: 880-2803
C: (201) 724-2802

AMCCOM ARSENALS

Rock Island Arsenal
ATTN: SMCRI-AOE/Mr. Richard Johnson
SMCRI-ENM³
Rock Island, IL 61299

AV: 793-5528
AV: 793-5363
C: (309) 794-xxxx

Rocky Mountain Arsenal
ATTN: SMCRM-TOI/Mr. Dave Strang
Commerce City, CO 80022-2180

AV: 556-2264
C: (303) 289-2264

Watervliet Arsenal
ATTN: SMCWV-ODP-S/Mr. Dominick Ippolito (C)
Watervliet, NY 12189

AV: 974-5719
C: (518) 266-5792

AMCCOM ARMY AMMUNITION PLANTS

Indiana Army Ammunition Plant
ATTN: SMCIN-EN/Mr. Gary McCloskey
Charlestown, IN 47111

AV: 366-7403
C: (812) 282-8961
ext. 7403

Iowa Army Ammunition Plant
ATTN: SMCIO-EN³
Middleton, IA 52638

AV: 585-7101
C: (319) 754-5731
ext. 710

Lone Star Army Ammunition Plant
ATTN: SMCLS-EN³
Texarkana, TX 75501

AV: 829-1305
C: (214) 838-1305

Radford Army Ammunition Plant
ATTN: SMCRA-EN/Mr. John C. Horvath
SMCRA-EN/Dr. Wynnell York (Alternate)
Radford, VA 24141

AV: 931-8641
AV: 931-8641
C: (703) 639-8641

ARMY MATERIEL COMMAND
CAD/CAM STEERING GROUP MEMBERS (CONT.)

AMCCOM ARMY AMMUNITION PLANTS

Riverbank Army Ammunition Plant ATTN: SMCRB-ER 3 Riverbank, CA 95367	AV: 466-4236 C: (209) 529-8100 ext. 4236
Scranton Army Ammunition Plant ATTN: SMCSC-EN 3 Scranton, PA 18505-1138	AV: 247-1358 C: (717) 342-7801 ext. 358
Volunteer Army Ammunition Plant ATTN: SMCVO-CO/Mr. James E. Fry P.O. Box 22607 Chattanooga, TN 37422-2607	AV: 431-3750 C: (615) 892-0115

DESCOM DEPOTS

Corpus Christi Army Depot ATTN: SDSCC-MPI/Mr. Roy Oliver SDSCC-MPDT/Mr. E. V. Garcia (Alternate) Corpus Christi, TX 78419	AV: 861-3243 AV: 861-2423 C: (512) 939-xxxx
Letterkenny Army Depot ATTN: SDSLE-MM/Mr. Jerry Kline Chambersburg, PA 17201	AV: 238-7638 C: (717) 263-7638
Sacramento Army Depot ATTN: SDSSA-MPE-4/Mr. William Humenick Sacramento, CA 95813-5036	AV: 839-3378 C: (916) 388-3378
Tobyhanna Army Depot ATTN: SDSTO-ME-E/Mr. Frank Estock Tobyhanna, PA 18466	AV: 795-7099 C: (717) 894-7099
Tooele Army Depot ATTN: SDSIE-MAE-S 3 Tooele, UT 84074	AV: 790-2860 C: (801) 833-2789

OTHER INSTALLATIONS/ACTIVITIES

US Army Management Engineering Training Activity (AMETA) ATTN: AMXOM-SE/Mr. Alvin K. Takemoto (C) AMXOM-SE/Mr. James O. Young (Alternate) Rock Island, IL 61299	AV: 793-4041 AV: 793-4041 C: (309) 794-4041
US Army Materials and Mechanics Research Center (AMMRC) ATTN: AMXMR-MDP/Mr. Roger Gagne (M) Watertown, MA 02172	AV: 955-5579 C: (617) 923-5579
US Army Logistics Systems Support Activity (LSSA) ATTN: AMXLS-LGP/Mr. Donald Cotabish Chambersburg, PA 17201	AV: 238-7131 C: (717) 263-7131

APPENDIX E
MTAG CAD/CAM SUBCOMMITTEE MEMBERS

CAD/CAM SUBCOMMITTEE
MEMBERSHIP LIST

Chairman

Mr. James Sullivan
US Army Industrial Base
Engineering Activity
ATTN: AMXIB-MT
Rock Island, IL 61299-7260
AV 793-6167/3682, (309) 794-6167/3682

Vice Chairman

Mr. Leo Plonsky
Naval Material Command Industrial
Resources Detachment
Code 06X26, Bldg 75-2
Philadelphia, PA 19112
AV 443-6686, (215) 897-6686/6687

ARMY

Mr. Bobby L. Austin
US Army Missile Command
ATTN: AMSMI-ET
Redstone Arsenal, AL 35898
AV 746-2147, (205) 876-2147

Mr. J. M. Carter
AMC Intern Training Center
ATTN: AMXMC-ITC-E
Red River Army Depot
Texarkana, TX 75507
AV 829-2001, (214) 838-2001

Mr. Michael J. Ahearn
US Army Depot Systems Command
ATTN: AMSDS-RM-EIT
Chambersburg, PA 17201
AV 238-6591, (717) 263-6591

Mr. William Garber
Watervliet Arsenal
ATTN: SMCWV-PPI
Watervliet, NY 12189
AV 974-4231, (518) 266-4231

Mr. Dom Ippolito
Watervliet Arsenal
ATTN: SMCWV-ODP-S
Watervliet, NY 12189
AV 974-5719, (518) 266-5719

Mr. Dave Pyrcce
US Army Tank-Automotive Command
ATTN: AMSTA-RCKM
Warren, MI 48090
AV 786-6722, (313) 574-6722

Ms. Carol Neckyfarow
US Army Materials & Mechanics
Research Center
ATTN: AMXMR-PP
Bldg. 131, Arsenal Street
Watertown, MA 02172
AV 955-5525, (617) 923-5526

Mr. Charles Kimzey
US Army Materiel Command
ATTN: AMCMT
5001 Eisenhower Ave.
Alexandria, VA 22333
AV 284-8298/8299, (202) 274-8298/8299

Mr. Gordon Little
US Army Missile Command
ATTN: AMSMI-ETE
Redstone Arsenal, AL 35898
AV 746-3604, (205) 876-3604

Mr. Victor Montuori
Benet Weapons Lab
ATTN: AMSMC-LCB-SE
Watervliet Arsenal
Watervliet, NY 12189
AV 974-5827, (518) 266-5507

MAJ W. Olson
Benet Weapons Lab
ATTN: AMSMC-LCB-SE
Watervliet Arsenal
Watervliet, NY 12189
AV 974-5703, (518) 266-5703

ARMY (cont.)

Mr. Ron Matteuzzi
US Army Aviation Systems Command
ATTN: AMSAV-PEC
4300 Goodfellow Blvd.
St. Louis, MO 63120
AV 693-2294, (314) 263-3079

Mr. Jim Harvey
US Army Communications Electronics
Command
ATTN: AMSEL-PC-SI-I-1
Fort Monmouth, NJ 07703
AV 992-4737, (201) 544-4737

Mr. Vince Scheno
US Army Armament, Munitions and
Chemical Command
ATTN: AMSMC-TSC-E (A)
Aberdeen Proving Ground, MD 21010
AV 584-3306, (301) 671-2938

Mr. Alvin Takemoto
US Army Management Engineering
Training Activity
ATTN: AMXOM-SE
Rock Island Arsenal
Rock Island, IL 61299
AV 793-4041, (309) 794-4041

Mr. Edwin L. Emerson
US Army Materials & Mechanics
Research Center
ATTN: AMXMR-MDP
Bldg. 312, Arsenal Street
Watertown, MA 02172
AV 955-5459, (617) 923-5459

NAVY

Mr. Forrest C. Gale
Defense Systems Management College
Laboratory Department
Bldg. 209, Room 119
Ft. Belvoir, VA 22060
AV 354-6811, (703) 664-6811

Ms. Oreta Stinson
Naval Air Systems Command
ATTN: Code AIR 5143J
Washington, DC 20361
AV 222-7640, (202) 692-7640

Mr. Gordon Lowham
Naval Weapons Center
Code 3646
China Lake, CA 93555
AV 437-3301, (714) 939-3301

Ms. Raye J. Montague
Naval Sea Systems Command
Code PMS 309C
Washington, DC 20362
AV 222-3024, (202) 692-7815

Dr. Michael Tuccio
Naval Underwater Systems Center
Code 4491
New London, CT 06320
AV 636-4971, (203) 440-4971

Mr. Roy N. Wells, Jr.
Naval Sea Systems Command
Code SEA 07032
Washington, DC 20362
AV 222-3581/3452, (202) 692-3580/3457

Mr. James M. Leland
Naval Air Rework Facility
North Island
Code 610C, Bldg 2
San Diego, CA 92135
(619) 437-6431

LCDR Bart Everett
Naval Sea Systems Command
Code 90M.3
Washington, DC 20362
AV 222-6118, (202) 692-6118

NAVY (Cont.)

Mr. John Hughes
Naval Ocean Systems Center
Code 9302
San Diego, CA 92152
AV 933-6457, (619) 225-6457

Mr. Robert L. Jenkins
David Taylor Naval Ship R&D Center
Code 1853
Bethesda, MD 20084
(202) 227-1363

Mr. Adrian Eversoll
Naval Weapons Support Center
Code 7021
Crane, IN 47522
AV 482-1668, (812) 854-1668

Mr. Ronald Wimmer
Naval Aviation Logistic Center
Code NALC 332
Paxtuxent River, MD 20670
AV 356-4194, (301) 863-4194

AIR FORCE

Cpt. Mike Strevell, Focal Point
Air Force Wright Aeronautical Lab
ICAM Program Office
ATTN: AFWAL/MLTC
Wright Patterson AFB, OH 45433
AV 785-7371, (513) 255-7371

Mr. Nick Bernstein
Air Force Wright Aeronautical Lab
ATTN: AFWAL/FIBR
Wright Patterson AFB, OH 45433
AV 785-6992, (513) 255-6992

Mr. John B. Eck
Aeronautical Systems Div.
ATTN: PMDP
Wright Patterson AFB, OH 45433

Mr. Pat Quinn
Air Force Logistics Command
ATTN: AFLC/MAXF
Wright Patterson AFB, OH 45433
AV 787-6164, (513) 257-6163

Mr. Gilbert Hays
Air Force Wright Aeronautical Lab
ATTN: AFWAL/MLTC
Wright Patterson AFB, OH 45433
AV 785-7371, (513) 255-7371

Mr. Richard L. Spahn
Air Force Systems Command
Space Division, ATTN: PDD
P.O. Box 92960, World Postal Ctr.
Los Angeles, CA 90009
AV 833-0854, (213) 643-0854

Mr. Don Simmons
Armament Division
ATTN: AD/PMD
Eglin AFB, FL 32542
AV 872-3254/4798

Mr. William Walden/Craig Burnett
Sacramento Air Logistics Center
ATTN: SM-ALC/MA
McClellan AFB, CA 95652
AV 633-2191

OTHER GOVERNMENT ORGANIZATIONS

National Aeronautics and Space
Administration

Mr. George C. Salley
Langley Research Center
Code LARC/246
Hampton, VA 23665
FTS - 928-2426
(804) 865-2426/2888

National Bureau of Standards

Mr. Bradford M. Smith
National Bureau of Standards
A353 Bldg. 220
Gaithersburg, MD 20899
(301) 921-3691

OTHER GOVERNMENT ORGANIZATIONS (Cont.)

Department of Energy

Mr. Sam M. Murphy, Jr.
Martin Marietta
Energy Systems Division
P.O. Box Y, Y-12 Plant
Oak Ridge, TN 37830
(615) 576-4891

Mr. William Sprague/Alternate
Bendix Corporation
Kansas City Division
Dept. 862, MB 40
P.O. Box 1159
Kansas City, MO 64141
(816) 997-4457

Defense Logistics Agency

Mr. Garland Smith
Defense Industrial Plant
Equipment Center
ATTN: TES
Airways Blvd.
Memphis, TN 38114
AV 683-6229, (901) 775-6229

Mr. Fred Lawson
Defense Logistics Agency
ATTN: DLA-SEE
Cameron Station
Alexandria, VA 22304-6100
AV 284-6775, (202) 274-6775

APPENDIX F
DISTRIBUTION

CAD/CAM HIGHLIGHTS

AMXIB-MT
DISTRIBUTION:

Department of Defense:

Defense Industrial Plant Equipment Center, ATTN: TES/Mr. Garland Smith
Defense Logistics Agency, ATTN: DLA-SEG/Mr. Fred Lawson
Defense Systems Management College, ATTN: Mr. Forrest Gale
OUSDRE (R&AT), The Pentagon, ATTN: Dr. Lloyd L. Lehn (3 cys)

Department of the Army:

HQDA, OASARDA, The Pentagon, ATTN: Mr. William Takakoshi
HQDA, DCSRDA, The Pentagon, ATTN: DAMA-PPM-P/LTC S. Marsh

US Army Materiel Command:

Cdr, ATTN: AMCCG
Cdr, ATTN: AMCDE
Cdr, ATTN: AMCDMD
Cdr, ATTN: AMCDMR
Cdr, ATTN: AMCIM-IP/Ms. Jessie Herr
Cdr, ATTN: AMCMT/Mr. Fred Michel (5 cys)
Cdr, ATTN: AMCMT-M/Mr. Chuck Kimzey
Cdr, ATTN: AMCMT-S/Mr. Jerry Holvoet
Cdr, ATTN: AMCPP
Cdr, ATTN: AMCPP-I
Cdr, ATTN: AMCPP-I/Ms. Mary Brittain
Cdr, ATTN: AMCPP-IF
Cdr, ATTN: AMCRE-C/Ms. Jean Lamb
Cdr, ATTN: AMCRM-P/Mr. Jerry Gibson
Cdr, ATTN: AMCQA-E/Mr. Billings
Cdr, ATTN: AMXAM-TL/Technical Library

US Army Armament, Munitions and Chemical Command:

Cdr, ATTN: AMSMC (D)
Cdr, ATTN: AMSMC-CG (R)
Cdr, ATTN: AMSMC-IRI (R)
Cdr, ATTN: AMSMC-IRI-M (R)/Mr. Alfred Khwaja
Cdr, ATTN: AMSMC-IRW-T (R)
Cdr, ATTN: AMSMC-LEP (R)/Mr. R. F. Tumasonis
Cdr, ATTN: AMSMC-LEP-L (R)/Technical Library (3 cys), [Defense Technical Information Center, ATTN: DDR-1 (2 cys)]
Cdr, ATTN: AMSMC-MA (R)/Mr. Don Braddock
Cdr, ATTN: AMSMC-MSE (R)/Mr. Thomas Frandsen
Cdr, ATTN: AMSMC-OAA-S (R)/Mr. George Schlenker
Cdr, ATTN: AMSMC-PB (D)/Mr. Joseph Taglairino (4 cys)
Cdr, ATTN: AMSMC-PBM-TI (D)/Mr. Douglas Morlock
Cdr, ATTN: AMSMC-PBS-A (R)/Mr. Carrol Schumacher (4 cys)
Cdr, ATTN: AMSMC-PBT-I (D)/Mr. Tony D'Agosto
Cdr, ATTN: AMSMC-QAH-T (D)/Mr. E. Barnes
Cdr, ATTN: AMSMC-SAS (R)/Mr. Gerald Moeller
Cdr, ATTN: AMSMC-TSC-E (A)/Mr. Vince Scheno

AMXIB-MT

DISTRIBUTION (Cont'd):

US Army Armament, Munitions and Chemical Command:

Armament R&D Center:

Cdr, ATTN: ESPD-LCM-E/Mr. Harold Kesselman
Cdr, ATTN: SMCAR-LCA-P/Mr. J. Pustai
Cdr, ATTN: SMCAR-PBE-P/Mr. Olin Colitti
Cdr, ATTN: SMCAR-PMP-P/Mr. Donald J. Fischer (4 cys)
Cdr, ATTN: SMCAR-SCF-D/Mr. Nate Scott
Cdr, ATTN: SMCAR-TS/Mr. William Schultz
Cdr, ATTN: SMCAR-TSE-I/Mr. Art Reimer
Cdr, ATTN: SMCAR-TSF-D/Mr. Donald O'Connor
Cdr, ATTN: SMCAR-TST-S/Mr. Maurice Taylor

Chemical R&D Center:

Cdr, ATTN: SMCCR-CLY-T/Technical Library
Cdr, ATTN: SMCCR-ES/Mr. Tom Mazza
Cdr, ATTN: SMCCR-PMI/Mr. Joe Abbott
Cdr, ATTN: SMCCR-SPD-E
Cdr, ATTN: SMCCR-TDP/Mr. Bruce Jezek

US Army Aviation Systems Command:

Cdr, ATTN: AMSAV-ESV/Mr. Don Watkins
Cdr, ATTN: AMSAV-NC/Mr. S. Meyer
Cdr, ATTN: AMSAV-PEC/Mr. Fred Reed, Mr. Ron Matteuzzi

US Army Ballistic Research Lab:

Dir, ATTN: AMXBR-BL (A)
Dir, ATTN: AMXBR-BLV-V (A)/Dr. Paul Deitz
Dir, ATTN: AMXBR-TSB-S (A)

US Army Belvoir R&D Center:

Cdr, ATTN: STRBD
Cdr, ATTN: STRBD-BS/Mr. D. Scott
Cdr, ATTN: STRBD-DE/Mr. Norman Lekang
Cdr, ATTN: STRBD-HE/Mr. K. K. Harris
Cdr, ATTN: Technical Library

US Army Communications & Electronics Command:

Cdr, ATTN: AMSEL
Cdr, ATTN: AMSEL-MS-T/Mr. John Demko
Cdr, ATTN: AMSEL-POD/Mr. Mike Bananti
Cdr, ATTN: AMSEL-POD-P-G/Mr. Feideler
Cdr, ATTN: AMSEL-PC-SI-I/Mr. Leon Field
Cdr, ATTN: AMSEL-PC-SI-I-1/Mr. Jim Harvey
Cdr, ATTN: AMSEL-PC-SI-I-2/Mr. James Kelly
Cdr, ATTN: RD&E Technical Documents Center

US Army Depot Systems Command:

Cdr, ATTN: AMSDS
Cdr, ATTN: AMSDS-RM-EIT/Mr. Mike Ahearn
Cdr, ATTN: AMSDS-OM/Mr. Tom Wolf

AMXIB-MT

DISTRIBUTION (Cont'd):

US Army Electronics R&D Command:

Cdr, ATTN: AMDEL
Cdr, ATTN: AMDEL-PO-SP/Mr. Harold Garson
Cdr, ATTN: DELET-IC-K/Mr. Randy Reitmeyer
Cdr, ATTN: DELET-R/Mr. Key
Cdr, ATTN: DELHD-IT-R/Mr. Robert Rosen

US Army Materials & Mechanics Research Center:

Dir, ATTN: AMXMR, AMXMR-M (3 cys ea)
Dir, ATTN: AMXMR-EO/Dr. Morton Kliman
Dir, ATTN: AMXMR-MDP/Mr. Roger Gagne
Dir, ATTN: AMXMR-PP/Mr. John Gassner
Dir, ATTN: Technical Library

US Army Missile Command:

Cdr, ATTN: AMSMI
Cdr, ATTN: AMSMI-ED/Mr. C. F. Goessling
Cdr, ATTN: AMSMI-EDD/Mr. William McMillan
Cdr, ATTN: AMSMI-ET/Mr. Bobby Park
Cdr, ATTN: AMSMI-RDF/Dr. Hallum
Cdr, ATTN: AMSMI-RLC/Mr. Richard Eppes, Jr.
Cdr, ATTN: RSIC/Magazine Room

US Army Natick R&D Center:

Cdr, ATTN: STRNC
Cdr, ATTN: STRNC-EML/Mr. Dan DaLuz
Cdr, ATTN: AMXTM-TRL/Technical Library

US Army Tank-Automotive Command:

Cdr, ATTN: AMSTA
Cdr, ATTN: AMSTA-ICC/Mr. Chester Zack
Cdr, ATTN: AMSTA-QAT/LT Young Chae
Cdr, ATTN: AMSTA-RCKM/Mr. Don Cargo
Cdr, ATTN: AMSTA-TDS/Mr. Samir Khourdaji
Cdr, ATTN: Technical Library

US Army Test & Evaluation Command:

Cdr, ATTN: AMSTE
Cdr, ATTN: AMSTE-AD-M/Mr. William Deaver

US Army Troop Support Command:

Cdr, ATTN: AMSTR
Cdr, ATTN: AMSTR-PF/Mr. Ernie Russell
Cdr, ATTN: AMSTR-PT/Mr. Richard Green
Cdr, ATTN: AMSTR-PLEP-2

Aberdeen Proving Ground:

Cdr, ATTN: STEAP-MT-M/Mr. J. L. Sanders
Cdr, ATTN: STEAP-MT-G/Mr. Michael Drabo

AMXIB-MT
DISTRIBUTION (Cont'd):

Rock Island Arsenal:

Cdr, ATTN: SMCRI-AOE/Mr. Richard Johnson
Cdr, ATTN: SMCRI-AOI/Mr. John Wilkins
Cdr, ATTN: SMCRI-CO
Cdr, ATTN: SMCRI-ENM/Mr. J. W. McGarvey
Cdr, ATTN: SMCRI-ENM-T/Dr. Richard Kalkan

Watervliet Arsenal:

Cdr, ATTN: SMCWV-CO
Cdr, ATTN: SMCWV-ODP-S/Mr. Dominick Ippolito
Cdr, ATTN: SMCWV-PPI/Mr. Charles Hall
Cdr, ATTN: SMCWV-LCB-DR/Mr. Eugene Coppula
Cdr, Benet Weapons Lab, ATTN: AMSMC-LCB-S/Dr. F. Heiser
Cdr, Benet Weapons Lab, ATTN: AMSMC-LCB-SE/MAJ W. Olson, Mr. V. Montuori
Cdr, Benet Weapons Lab, ATTN: AMSMC-LCB-TL/Tech Library

Arsenals:

Cdr, Pine Bluff Arsenal (PBA), ATTN: SMCPB-CO
Cdr, Rocky Mountain Arsenal (RMA), ATTN: SMCRM-IS, SMCRM-TOI/Mr. Dave Strang

Army Ammunition Plants: (1 cy ea)

Cdr, Crane AAP, ATTN: SMCCN, SMCCN-QAM-C/Mr. S. R. Caswell
Cdr, Hawthorne AAP, ATTN: SMCHW-CO
Cdr, Holston AAP, ATTN: SMCHO-CO
Cdr, Indiana AAP, ATTN: SMCIN-CO, SMCIN-EN/Mr. Gary McCloskey
Cdr, Iowa AAP, ATTN: SMCIO-CO, SMCIO-EN/Ms. Judy Morgan
Cdr, Kansas AAP, ATTN: SMCKA-CO
Cdr, Lake City AAP, ATTN: SMCLC-CO
Cdr, Lone Star AAP, ATTN: SMCLS-CO, SMCLS-EN/Mr. Jerry Melito
Cdr, Longhorn AAP, ATTN: SMCLO-CO
Cdr, Louisiana AAP, ATTN: SMCLA-CO
Cdr, McAlester AAP, ATTN: SMCMC-PM/Mr. Garold Stevens
Cdr, Milan AAP, ATTN: SMCMI-CO
Cdr, Mississippi AAP, ATTN: SMCMS
Cdr, Radford AAP, ATTN: SMCRA-CO, SMCRA-EN/Mr. John Horvath
Cdr, Riverbank AAP, ATTN: SMCRB-CO, SMCRB-ER/Mr. Jim Gansel
Cdr, Scranton AAP, ATTN: SMCSC-CO, SMCSC-EN/Mr. Morgan Benson
Cdr, Volunteer AAP, ATTN: SMCVO-CO/Mr. James Fry

Depots:

Cdr, Anniston Army Depot, ATTN: SDSAN-MD
Cdr, Corpus Christi Army Depot, ATTN: SDSCC-CM/Mr. Jack Brooks,
SDSCC-MPI/Mr. Roy Oliver
Cdr, Letterkenny Army Depot, ATTN: SDSLE-MM/Mr. Michael Bacellieri
Cdr, New Cumberland Army Depot, ATTN: SDSNC-ME
Cdr, Red River Army Depot, ATTN: SDSRR-MO, SDSRR-ME/Mr. Larry Ford
Cdr, Sacramento Army Depot, ATTN: SDSSA-MPE, SDSSA-MPE-4/Mr. William Humenick,
Mr. Jody Shlotzhauer, Mr. Duane George, SDSSA-MP-4/Mr. Bill Hobbs

AMXIB-MT

DISTRIBUTION (Cont'd):

Depots (Cont'd):

Cdr, Tobyhanna Army Depot, ATTN: Technical Library, SDSTO-ME-E/
Mr. Frank Estock, SDSTO-MP-R/Mr. Don Smith, SDSTO-M/Mr. Jerry Collins
Cdr, Tooele Army Depot, ATTN: SDSTE-FM, SDSTE-MAE-S, SDSTE-MAE/
Mr. Stephen Sands, SDSTE-MAE-E/Mr. Jim Jarvis

Army Organizations:

Dir, AMC Intern Training Center, ATTN: AMXMC-ITC-E/Mr. Carter
Cdr, Army Applied Tech Labs, ATTN: DAVDL-ATL-ATS/Mr. J. Waller
Cdr, Army Construction Engineering Research Lab, ATTN: Mr. Frank Kearney
Cdr, Army Human Engineering Lab, ATTN: AMXHE-CS/Mr. Chuck Shoemaker, AMXHE-AR/
Mr. Bill Hall
Dir, Army Installation & Services Actvty, ATTN: AMXEN-IM/Mr. Ray Shinbori
Cdr, Army Logistics Management Center, ATTN: AMXMD
Cdr, Army Logistics Systems Support Activity, ATTN: AMXLS-LGP/Mr. Don Cotabish
Dir, Army Management Engineering Training Activity (AMETA), ATTN: AMXOM-SE/
Dr. Shallman (3 cys), Mr. Alvin Takemoto
Cdr, Army TMDE Support Group, ATTN: AMXTM/Mr. Ken Magnant
Cdr, Dugway Proving Grounds, ATTN: Technical Library
Cdr, Foreign Science & Tech Ctr, ATTN: AMXST-SDI/Mr. Kent Schlusel
Cdr, Harry Diamond Labs, ATTN: DELHD-PO/Mr. Julius Hoke
Cdr, Night Vision & Electro-Optic Lab, ATTN: DELNV-SE
Cdr, West Coast - TILO, ATTN: Mr. C. Green
Cdr, White Sands Missile Range, ATTN: STEWS-TE-TL/Technical Library
Cdr, US Military Academy, ATTN: LTC Lanse Leach
Cdr, Yuma Proving Grounds, ATTN: Technical Library

Navy Organizations:

Cdr, David Taylor Naval Ship R&D Center, ATTN: Code 1853/Mr. Robert Jenkins
Cdr, Long Beach Naval Shipyard, ATTN: Code 300.02/Mr. C. Rogers
Cdr, Naval Air Rework Facility, ATTN: Code 610C/Mr. James Leland
Cdr, Naval Air Systems Command, ATTN: Code AIR7640/Mr. R. A. Retta,
Code AIR5143J/Ms. Oreta Stinson
Cdr, Naval Aviation Logistics Center, ATTN: Code NALC 332/Mr. Ron Wimmer
Cdr, Naval Avionics Center, ATTN: Code 240/Mr. Larry Halbig
Cdr, Naval Material Command, ATTN: Code 064/Mr. J. W. McInnis
Dir, Naval Mat Comd Ind Resources Detachment, ATTN: Officer-In-Charge,
Code 06X26/Mr. Leo Plonsky
Cdr, Naval Ocean Systems Center, ATTN: Code 926/Dr. Wil Watson, Code 9302/
Mr. John Hughes
Cdr, Naval Sea Systems Command, ATTN: Code SEA-05R23/Mr. T. E. Draschil,
Code SEA 07032/Mr. Roy Wells, Jr., Code 90M.3/LCDR Bart Everett,
Code PMS 309C/Ms. Raye Montague
Cdr, Naval Surface Wpns Ctr/Dahlgren Lab, ATTN: Code E431
Cdr, Naval Surface Wpns Ctr/White Oak Lab, ATTN: Code E345/Mr. Chas. McFann
Cdr, Naval Weapons Center, ATTN: Code 36404, Code 3646/Mr. Gordon Lowham
Cdr, Naval Weapons Support Center: ATTN: Code 7021/Mr. Adrian Eversoll
Cdr, Naval Underwater Systems Center, ATTN: Code 4491/Dr. Michael Tucchio

AMXIB-MT
DISTRIBUTION (Cont'd):

Air Force:

Cdr, Air Force, ATTN: USAF/RDCM/MAJ E. Ross, The Pentagon
Cdr, Air Force Logistics Command, ATTN: AFLC/MAXF/Mr. Pat Quinn
Cdr, Air Force Systems Command, ATTN: AFSC/DLF, AFSC/PDD/Mr. Richard Spahn
Cdr, Air Force Wright Aeronautical Lab, ATTN: AFWAL/LT, AFWAL/LTE, AFWAL/LTM,
AFWAL/LTN, AFWAL/MLSS, AFWAL/MLTC/CPT Mike Strevell
AFWAL/FIBR/Mr. Nick Bernstein, PMDP/Mr. John Eck
Cdr, Armament Division, ATTN: AD/PMD/Mr. Don Simmons
Cdr, Hanscom AFB, ATTN: AFGL-SULL/R. Bergmann
Cdr, Sacramento Air Logistics Ctr, ATTN: SM-ALC/MA/Mr. Walden
Cdr, San Antonio Air Logistics Ctr, ATTN: B. Boisvert-MMEI, Kelly AFB

Other Government:

Department of Energy, ATTN: Mr. Sam Murphy, Jr., Martin Marietta, P.O. Box Y,
Oak Ridge, TN 37830
Department of Energy, ATTN: Mr. Clarence Williams, Bendix Corp., Kansas City,
MO 64141
National Bureau of Standards, ATTN: Mr. Brad Smith, Gaithersburg, MD 20899

Professional Societies:

Aerospace Industries Association, ATTN: Mr. Walter Weitner,
1725 Desales St., N.W., Washington, DC 20036
American Defense Preparedness Association, ATTN: Mr. William Holt,
1700 N. Moore Street, Arlington, VA 22209
American Society for Metals, ATTN: Mr. James Hontas, Metals Park, OH 44073
American Society for Testing and Materials, ATTN: Mr. Samuel F. Etris,
Special Assistant, 1916 Race St., Philadelphia, PA 19103
Assoc. for Integrated Mfg Technology, ATTN: Ms. Marti DeGraaf, 111 E. Wacker
Dr., Suite 600, Chicago, IL 60601
Cast Metal Federation, ATTN: Mr. William E. Gephardt, Chairman, Govt.
Supply Committee, 4870 Packard Road, Niagara Falls, NY 14304
Electronics Industries Association, ATTN: Mr. Jean Caffiaux, 2001 I St., N.W.,
Washington, DC 20006
Forging Industry Association, ATTN: Mr. C. G. Scofield, Room 1121,
55 Public Square, Cleveland, OH 44113
Metcut Research Associates, Inc., ATTN: Mr. John F. Kahles, 3980 Rosslyn
Drive, Cincinnati, OH 45209
Society of Manufacturing Engineers, ATTN: Mr. Tom Heath, One SME Drive,
P.O. Box 930, Dearborn, MI 48121

END

FILMED

4-85

DTIC