

AD-A151 289

ENTROPY PRODUCTION DURING FATIGUE AS A CRITERION FOR
FAILURE A LOCAL THEO. (U) NEBRASKA UNIV LINCOLN COLL OF
ENGINEERING AND TECHNOLOGY P W WHALEY 15 DEC 84 TR-2

1/1

UNCLASSIFIED

N00014-82-K-8804

F/G 20/11

NL

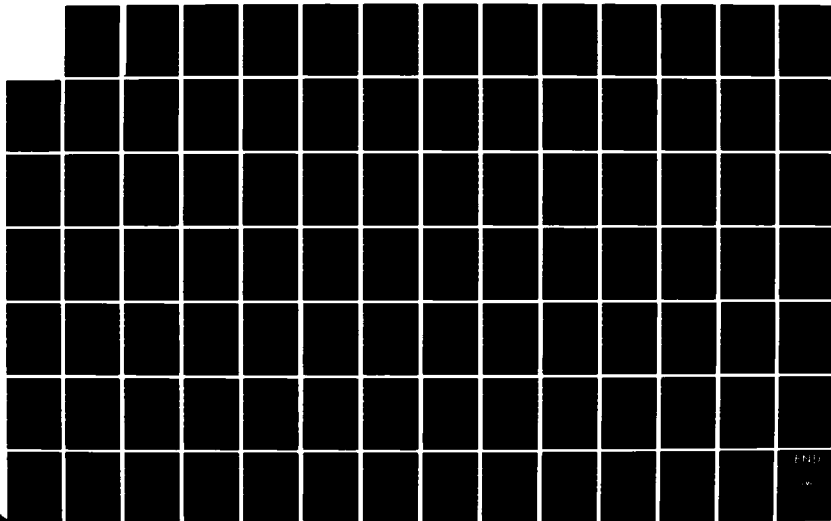

END

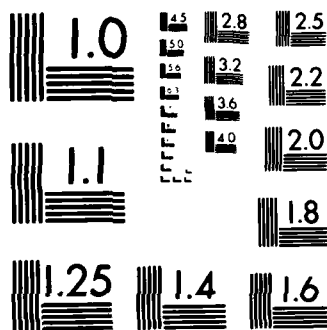

MICROCOPY RESOLUTION TEST CHART
NATIONAL BUREAU OF STANDARDS-1963-A

AD-A151 289

ONR Technical Report No.2
Final Report
Contract N00014-82-K-0804
NR 229-046

ENTROPY PRODUCTION DURING FATIGUE AS A CRITERION FOR FAILURE

A Local Theory of Fracture in Engineering Materials

P.W. Whaley
College of Engineering and Technology
University of Nebraska-Lincoln

15 December 1984

Approved for Public release; distribution unlimited.
Reproduction in whole or in part is permitted for any
purpose of the United States Government.

DTIC FILE COPY

Prepared for:

OFFICE OF NAVAL RESEARCH
800 N. Quincy St.
Arlington VA 22217

SELECTED
MAR 18 1985
A

85 03 08 059

REPORT DOCUMENTATION PAGE		READ INSTRUCTIONS BEFORE COMPLETING FORM								
1. REPORT NUMBER ONR Technical Report No. 2	2. GOVT ACCESSION NO. AD-A151 289	3. RECIPIENT'S CATALOG NUMBER								
4. TITLE (and Subtitle) ENTROPY PRODUCTION DURING FATIGUE AS A CRITERION FOR FAILURE A Local Theory of Fracture in Engineering Materials		5. TYPE OF REPORT & PERIOD COVERED Final 15 Aug 1982-31 Oct 1984								
		6. PERFORMING ORG. REPORT NUMBER								
7. AUTHOR(s) P. W. Whaley		8. CONTRACT OR GRANT NUMBER(s) N00014-82K-0804								
9. PERFORMING ORGANIZATION NAME AND ADDRESS College of Engineering University of Nebraska Lincoln, Nebraska 68588		10. PROGRAM ELEMENT, PROJECT, TASK AREA & WORK UNIT NUMBERS NR 229-046								
11. CONTROLLING OFFICE NAME AND ADDRESS OFFICE OF NAVAL RESEARCH 800 N. Quincy St. Arlington, VA 22217		12. REPORT DATE 15 Dec 1984								
		13. NUMBER OF PAGES 86								
14. MONITORING AGENCY NAME & ADDRESS (if different from Controlling Office)		15. SECURITY CLASS. (of this report) Unclassified								
		15a. DECLASSIFICATION/DOWNGRADING SCHEDULE								
16. DISTRIBUTION STATEMENT (of this Report) Approved for public release; distribution unlimited. Reproduction in whole or in part is permitted for any purpose of the United States Government.										
17. DISTRIBUTION STATEMENT (of the abstract entered in Block 20, if different from Report)										
18. SUPPLEMENTARY NOTES										
19. KEY WORDS (Continue on reverse side if necessary and identify by block number)										
<table border="0"> <tr> <td>Fatigue Crack Initiation</td> <td>Fatigue Theories</td> </tr> <tr> <td>Fatigue Crack Nucleation</td> <td>Material Damping Measurements</td> </tr> <tr> <td>Fatigue Damage</td> <td>Material Damping Theories</td> </tr> <tr> <td>Fatigue Testing</td> <td>Fatigue Crack Growth</td> </tr> </table>			Fatigue Crack Initiation	Fatigue Theories	Fatigue Crack Nucleation	Material Damping Measurements	Fatigue Damage	Material Damping Theories	Fatigue Testing	Fatigue Crack Growth
Fatigue Crack Initiation	Fatigue Theories									
Fatigue Crack Nucleation	Material Damping Measurements									
Fatigue Damage	Material Damping Theories									
Fatigue Testing	Fatigue Crack Growth									
20. ABSTRACT (Continue on reverse side if necessary and identify by block number)										
<p>➤ A mathematical model of fatigue crack nucleation initiation, and propagation is described using irreversible thermodynamics to quantify the damage caused by plastic straining. A mathematical model for local random yielding is used to derive a local theory of fracture and fatigue crack growth. The classical results of linear elastic fracture mechanics are reproduced; necessary and sufficient conditions for crack extension, critical stress and crack length, and sigmoidal shape of the crack growth curve.</p>										

However, this model is not limited to small-scale yielding, includes treatment of loading history, and can be applied to crack growth retardation and closure as well as combined loading and spectrum loading.

Originals - supplied keywords included: → front p.

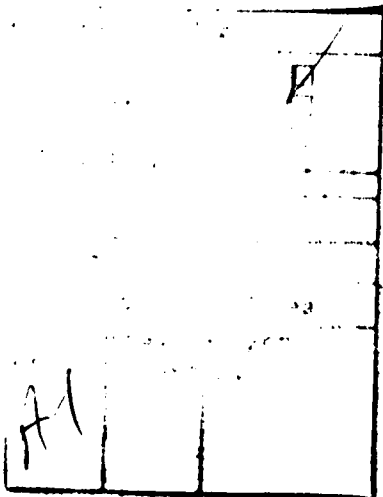

TABLE OF CONTENTS

	<u>PAGE</u>
LIST OF FIGURES.....	ii
NOMENCLATURE.....	iii
SUMMARY OF IMPORTANT RESULTS AND CONCLUSIONS.....	v
BACKGROUND AND LITERATURE SURVEY	1
Irreversible Thermodynamics.....	3
Fracture Mechanics.....	6
Dislocation Theory.....	10
Plasticity Theory.....	12
A THEORY OF FRACTURE BASED ON LOCAL RANDOM YIELDING	17
Stresses and Strains near a Crack Tip	20
A Local Criterion for Crack Extension.....	24
Fracture Toughness and Crack Blunting.....	28
INTERNAL FRICTION BASED ON LOCAL RANDOM YIELDING	31
Hysteresis Damping from Dynamic Plastic Strain	31
A Model for Fatigue Crack Nucleation	36
CRACK GROWTH DURING CYCLIC LOADING	39
Growth of Small Cracks	42
Influence of Loading Order	44
Crack Growth With Mean Stress	48
DISCUSSION OF DAMAGE IN METALS	50
APPLICATIONS TO COMPOSITE MATERIALS	52
Damping in Fiber-reinforced Laminated Beams	55
Energy Dissipation and Fatigue in Thin Laminated Beams	58
Failure Modes in Thick Beams	65
Analysis of Fracture in Composites	68
RECOMMENDATIONS AND CONCLUSIONS	71
REFERENCES	76
DISTRIBUTION LIST	83

LIST OF FIGURES

<u>FIGURE</u>	<u>PAGE</u>
1. Spring-Mass-Friction Infinitesimal Model for Local Random Yielding	18
2. Local Stress-Strain Relationship and Strain Energy Density from Local Random Yielding for High Strains Corresponding to Large Scale Yielding	21
3. Stresses and Strains by Local Random Yielding near an Elliptical Hole in an Infinite Thin Sheet	23
4. Critical Stress Versus Critical Crack Length for Various Crack Sharpness During Local Random Yielding	26
5. Variation of Critical Crack Tip Bluntness With Critical Crack Length	29
6. Definition of Loss Factor Defined by Dynamic Tangent Modulus from Local Random Yielding Under Cyclic Load ..	32
a. Change in Probability Structure Due to Yielding	
b. Definition of Loss Factor from Complex Modulus	
7. Loss Factor as a Function of Frequency and Strain Amplitude for Local Random Yielding in Aluminum	35
a. Loss Factor as a Function of Frequency	
b. Loss Factor as a Function of Strain Amplitude	
8. Crack Nucleation Lifetime for Small Cracks and Different Values of b/a	37
a. Parallel Dashpot (Common Stress) Representation of Entropy Gain	
b. Crack Nucleation Lifetime Based on Critical Entropy Threshold for Various Crack Sharpness	
9. Crack Growth Rate During Cyclic Loading Versus Stress Intensity Amplitude for Different Fracture Toughness....	43
10. Initiation of Growth of Small Cracks	45
11. Effect of Loading Variation on Crack Growth	47
12. Crack Growth Rate Dependence On Mean Stress	49
13. Stress-Strain relationships in Laminated Beams	56
14. Laminate Damping Model Based on Local Random Yielding Along with Data from Gibson [72].....	59
15. Fatigue Lifetime to 30 percent Stiffness Reduction for Unidirectional and Cross-ply Laminated Beams	64
16. Fatigue Lifetime to 30 percent Stiffness Reduction for Thick Beams	67

NOMENCLATURE

ENGLISH:

a	crack length
a_c	critical crack length
b/a	crack tip bluntness parameter
$b/a _c$	critical crack tip bluntness parameter
c	locus of ellipse and hyperbola in curvilinear coordinates
\bar{D}	composite beam stiffness matrix
E	Young's modulus
E_s	dynamic storage modulus
E_t	tangent modulus
f	frequency
K_c	fracture toughness
K_I	stress intensity factor
ΔK_I	stress intensity amplitude
m	exponent of stress intensity amplitude in Paris crack growth equation
N	cycles
N_f	cycles to crack nucleation
$P(\epsilon)$	random yielding probability distribution function
S	local entropy gain
\dot{S}	local entropy rate
U_0	activation energy
W	local strain energy density
$[Q]$	laminate stiffness matrix

Greek:

ϵ	strain
ϵ_p	plastic part of strain
ϵ_v	strain in curvilinear coordinates
$\Delta\epsilon_p$	plastic strain range
ϵ_s	dynamic strain amplitude
γ	frequency exponent describing frequency dependence of elastic loss factor
η_e	elastic part of loss factor
η_0	reference elastic loss factor
η_p	plastic part of loss factor
η_s	total frequency- and amplitude-dependent loss factor
σ_c	critical remote stress
σ_{max}	maximum stress on an elliptical hole
σ_0	standard deviation of random yielding
σ_r	applied remote stress
σ_s	dynamic stress amplitude
ϕ_e	phase between stress and strain from elastic loss factor
ϕ_p	phase between stress and strain from plastic loss factor
θ	temperature
ν	hyperbola parameter in curvilinear coordinates
ς	ellipse parameter in curvilinear coordinates

SUMMARY OF IMPORTANT RESULTS AND CONCLUSIONS

A local analysis of the crack growth problem is described in this report. A microstructure model of spring-mass-friction microelements is described such that the behavior of dislocation populations is quantified by random yielding. The probability distribution function describing the frictional slip between microelements is used to define the local strain energy density. Using a log-normal probability distribution function for the yielding between microelements, a local necessary and sufficient condition for unstable crack growth is derived which is consistent with linear elastic fracture mechanics. This is in contrast to the classical Griffith criterion which is only a necessary condition. In addition, the Griffith criterion holds for small scale yielding while the local random yielding analysis applies to every deformation. The familiar sigmoidal shape of the crack growth rate versus stress intensity amplitude is produced, as well as the increased crack growth rate of small cracks where plastic deformation is significant. A threshold stress intensity factor is defined theoretically, and the growth of small cracks can be investigated directly. Also, crack growth dependence on stress history is demonstrated, as well as crack growth under mean stress. Since the local random yielding mathematical model of crack growth reproduces the well known fracture and crack growth relationships for metals, its credibility for studies of crack closure and retardation, resonance, and spectrum loading is validated. Its value as a mathematical model of fatigue damage and fracture should be exploited.

The local random yielding model provides a relationship between microstructure distributions and fracture mechanics. Since the local random yielding provides a quantitative estimate of the plastic strain, it also supplies a theory of plasticity for fracture mechanics. In addition, since plastic deformation involves changes of the plastic strain energy density the local random yielding model can be expressed in terms of irreversible thermodynamics: plastic deformation is accompanied by an irreversible entropy gain which can be defined in such a way as to reduce the second law of thermodynamics to an equality. The necessary and sufficient condition for unstable crack growth corresponds to a constant plastic work for a given material, which for isothermal processes is also a constant irreversible entropy gain. Therefore, the local random yielding model for local crack growth provides a common link between irreversible thermodynamics, microstructure theory, fracture mechanics, and plasticity theory. On the basis of these observations, it is postulated that the local irreversible entropy gain at crack extension is a material constant which quantifies fatigue damage and crack growth. This critical local irreversible entropy gain is called the critical entropy threshold and represents the toughness of a material; that is, the amount of irreversible damage a material can withstand before molecular bonds break.

BACKGROUND AND LITERATURE SURVEY

Fatigue damage is a serious threat to structural durability. Structures designed for static strength requirements can fail unexpectedly and catastrophically when subjected to periodic loading. Although the precise mechanism of strength degradation during fatigue is the subject of significant research efforts, substantial progress has been made in evaluating the effect of cyclic loading on structural durability. Miner[1] was one of the first ones to quantify fatigue when he summarized constant-amplitude fatigue data by the empirical relationship between the stress amplitude and cycles required for failure. He hypothesized that under variable amplitude loading, the life fractions of the individual amplitudes sum to unity. Although this hypothesis is inaccurate since loading history is important, Miner sums are still used in some applications.

Many other researchers have investigated the various aspects of fatigue damage since Miner's work was published. Manson[2] related the material mechanical properties to the particular form of the S-N diagram with some success. Concurrent with Manson's research, Coffin[3] investigated fatigue for various strain levels of excitation and the Manson-Coffin relationship was developed. Tavernelli and Coffin[4] described an analysis of fatigue life for metals under high amplitude cyclic excitation, providing acceptable agreement to data. More recently, emphasis has shifted into two areas: First, since no fracture would be expected without cracking, fracture mechanics analysis fills an important role in fatigue life prediction. Second, structures excited by

cyclic loading sometimes respond in resonance which is strongly influenced by the material damping. The relationship between material damping and fatigue damage has become a very important area of research.

Mason[5] was one of the earliest investigators to relate damping data to the prediction of fatigue lifetime. His experimental apparatus was capable of generating very high strain amplitudes, and he related measurements of internal friction to the fatigue lifetime in metals. This was a logical approach since Granato and Lucke[6] had already developed a model for internal friction based on dislocation theory. This investigation of the relationship between internal friction and fatigue related the energy dissipated during forced vibration to breaking of molecular bonds in dislocation migration leading to crack formation. Feltner and Morrow[7] used this interpretation as the basis for a hypothesis that microplastic hysteresis energy is a constant at fatigue failure. Although they were able to achieve acceptable correlation with fatigue data for steel by selecting parameters for the Manson-Coffin relationship, Martin[8] later showed that microplastic strain energy dissipated is not constant at fatigue failure, but suggested that it increases with fatigue lifetime in a predictable manner.

The energy transfer due to material damping during fatigue and fracture is a fundamental irreversible thermodynamic process. Perhaps one reason why the previous energy relationships in fatigue have not met with general success is that the theory of irreversible thermodynamics was absent from the early analysis. In order to provide a comprehensive

analysis of the energy transfer during fatigue, the theory of irreversible, non-equilibrium, nonlinear thermodynamics must be addressed. The microplastic hysteresis energy is related to dislocation theory, which is directly related to plasticity theory, and both are related to fracture mechanics. The remainder of this introductory section will be devoted to surveying the literature in these four main areas related to fatigue damage: (1) irreversible thermodynamics, (2) fracture mechanics, (3) dislocation theory (4) plasticity theory.

Irreversible Thermodynamics

The area of irreversible thermodynamics is generally recognized to be very important in the analysis of material fatigue and fracture. In the case of fatigue, damage occurs as a result of local accumulations of plastic strain energy. Since plastic deformation is irreversible, it must be accompanied by some irreversible entropy gain. In the case of fracture, linear elastic fracture mechanics is based on the analysis of energy released as a crack extends. There have been some recent advances of plasticity theory based on irreversible thermodynamics which can be used to quantify the memory of plastic deformation.

For any irreversible thermodynamic process, the theory of classical thermodynamics (including the Gibbs and Helmholtz equations) must be applied very carefully. One very important limitation of classical thermodynamics is that equilibrium is implied. By definition, irreversible processes are non-equilibrium in nature, and it is necessary to define smaller intervals of time where changes occur slowly enough so

that each small interval can be approximated by equilibrium. In a recent survey, Germain, et.al.[9] summarized two current views of irreversible thermodynamics. One view, rational thermodynamics, asserts that introduction of thermodynamic concepts into moving, continuous media requires a complete rethinking and reformulation of classical thermodynamics. A second view holds to the approximate validity of classical thermodynamics near equilibrium for processes which change slowly. It is necessary to consider which thermodynamic variables are well defined and useful in non-equilibrium, irreversible thermodynamic processes, and which variables should be redefined. Reference [9] is a discussion of these considerations and provides valuable insight for the irreversible, non-equilibrium thermodynamic analysis of fatigue and fracture.

The first and second laws of thermodynamics define the energy balance and entropy function in classical thermodynamics. The energy balance is generally based on the energy equivalence of work and heat, while the entropy function can be interpreted in a number of ways, depending on the application. For closed reversible processes where the beginning and end points are the same the net entropy gain is zero. For open reversible processes where the beginning and end points are not the same, the entropy gain is not zero but is well defined by the second law of thermodynamics as a function of the heat flux. In this case, the second law of thermodynamics defines the permissible steady-state flow of energy. In the case of open irreversible processes, the reversible entropy forms a lower bound and the second law of

thermodynamics becomes a statement of accessibility. For irreversible processes, the second law can be characterized in terms of entropy as follows: the entropy function exists and in the absence of internal constraints, the equilibrium state is that state which maximizes the entropy[10]. Irreversibility is also sometimes quantified by the Caratheodory conjecture: in the vicinity of an equilibrium state of a system there exist other states which cannot be reached quasistatically by reversible and adiabatic processes[10], [11], [12]. The Clausius-Duhem inequality defined in Reference [12] can be reduced to an equality by introducing the irreversible entropy as in References [13], [14] and [15].

Considering the assumed energy equivalence of heat and work implicit in the first law of thermodynamics, the irreversible entropy term can be defined in different ways. For example, in the case of viscoelasticity mechanical energy is dissipated and so is lost in terms of available useful energy. However, under steady-state vibration, the viscoelastic solid continues to dissipate energy and undergoes heating. As long as no permanent deformation occurs in the material the heat gained by the solid in the temperature increase is not an irreversible loss, since heat and work are equivalent forms of energy. Granted, such low-grade heat is of little practical value, but whether or not the process is considered to be irreversible depends on the purpose of the analysis and the definition of the entropy function.

It is widely accepted that the vast majority of dissipated energy in vibrating solids is converted to heat and stored in the temperature rise of the solid. Even though this low-grade

heat is lost in the sense that it can never be converted back into useful work, it does no damage as long as the material experiences no permanent deformation. For the purpose of quantifying fatigue damage, only the entropy gain contributed by the plastic deformation would be irreversible.

The methods of irreversible thermodynamics are fundamental to the analysis of fracture. First, the energy release rate during crack extension implicitly involves irreversible thermodynamics [16]. Second, the contribution of plastic strain energy to the phenomenon of fracture is related to the entropy gain [17]. References [18] and [19] describe thermodynamic relationships for creep damage and involve both the theory of fracture mechanics and the analysis of plastic strain. Burke and Cozzarelli[18] used a quantity called the continuity which represents the reduced load-carrying area during creep to define a damage state resulting from plastic deformation. McCartney[19] applied a continuum energy balance to creep, investigating linear and nonlinear fracture.

Irreversible thermodynamics is common in recent fracture mechanics publications. For materials with high ductility where small scale yielding does not apply, irreversible thermodynamics is needed to investigate the plastic strain energy near the crack tip. The literature concerning fracture mechanics is discussed in the next section.

Fracture Mechanics

Fracture mechanics deals with stress-strain relations near a crack tip in cracked solids in an effort to predict crack growth and failure. This theory has its origin in the early

work of Griffith[16] who formulated a fracture criterion for brittle materials. Using a stress analysis by Inglis[20], the energy per unit thickness of an infinite plate before and after the appearance of an infinitely thin elliptical crack was defined by the relationship between the stress far away from the crack and the stress at the crack tip. For brittle materials the theory is a linear one involving the strain energy release during fracture. Later Irwin[21] and Orowan[22] extended this approach to more ductile materials where plasticity effects can become significant.

Most current research is directed towards large scale yielding where crack tip plasticity effects are significant so that linear theory is overly conservative. It is necessary to review the fundamental philosophy behind the theory of fracture mechanics. Two main schools of thought dominate. First, the energy release rate defined by Griffith[16] reduces the fracture phenomenon to a global energy balance. Second, the stress intensity factor is used to characterize the crack tip stress in terms of the remote stress. For linear systems the energy release rate and the stress intensity factor are uniquely related and are equivalent. When plastic deformation is significant, it is common to use the path-independent contour integral defined by Rice[23] to investigate those relationships. Again, for linear systems this J-integral of Rice[23] is equivalent to the strain energy release rate defined by Irwin[21]. For all fracture mechanics approaches, the stress is considered to be singular at the crack tip for linear systems[24], [25], [26].

Thermodynamics has been established as an integral part of fracture mechanics and several papers have examined those thermodynamic foundations [27], [28]. The global energy balance represents a convenient mathematical tool for analysis of the singular terms at the crack tip. Gurtin[27] showed that provided the initial temperature is continuous at the crack tip, the Griffith fracture criterion is a necessary condition for crack initiation. Rice[28] related the elastic strain energy release rate developed by Irwin to the rate of entropy production at the crack tip. The difference between the Irwin strain energy release rate and the Griffith surface traction energy was defined as a thermodynamic force driving crack extension. Using the first and second laws of thermodynamics, the irreversible entropy (also called the entropy production) was shown to be proportional to the thermodynamic force. This entropy production can also be defined for irreversible thermodynamic processes in such a way as to reduce the Clausius-Duhem inequality to equality; the entropy production is zero when the process is reversible.

In a technical note Bodner, et.al.[29] suggested that a similar relationship holds for the crack propagation relationship under cyclic loading. Izumi, et.al[30] attempted to derive a plastic work relationship in the form of the Paris crack growth law. Badalian[31] defined crack propagation rate in terms of the strain energy density range, which is related to the Paris crack growth law for linear elastic systems by the relationship between stress intensity factor and strain energy release rate.

When plastic deformation at a crack tip is significant then linear elastic fracture mechanics does not apply. Weertman[32] approached the case of large-scale yielding by assuming that the material very close to a crack tip is approximately elastic, and defining a true stress intensity factor using the J-Integral. Batte, et.al.[33] provide a discussion of various approaches to post-yield conditions, outlining limitations of each of a variety of contour-integral procedures. Chudnovskii, et.al.[34] have developed a number of different path-independent contour integrals based on irreversible thermodynamics which relate the entropy production density to the stress singularity at a crack tip. Similarly, Aoki, et.al.[35] approached elastic-plastic fracture problems by the energy release rates associated with plastic deformation near a crack tip. Path-independent contour integrals were used to analyze the energy release rates associated with the translation, rotation, self-similar expansion and distortion of the fracture process region.

Weichert and Schonert[36] have made an important contribution to the thermodynamics of crack growth by investigating the heat generated at the tip of a growing crack. They report substantial temperature increase near a crack tip, providing support for the common assumption that most of the energy dissipated during crack growth is converted to heat. Considering the equivalence of heat and work assured by the first law of thermodynamics, their work raises question as to the source of the irreversible entropy (entropy production, or excess entropy). Perhaps a more precise form for the irreversible entropy during crack growth would be a function of

the plastic deformation, rather than the more general dissipation function which includes the effect of plastic as well as elastic deformation.

It is clear that fracture mechanics involves principles of irreversible thermodynamics. The Griffith fracture criterion and the path-independent contour integrals are energy relationships, as is the strain energy density function for crack propagation. However, fracture mechanics is based on empirical relationships prompting some researchers to examine the micromechanical structure of materials in an attempt to provide the theoretical basis for fracture. There have been advances in dislocation theory providing qualitative insight into the phenomena of fatigue and fracture. The next section will summarize some of the literature related to dislocation theory.

Dislocation Theory

While it is widely accepted that fracture cannot occur without cracking, the precise source of the crack nucleation is not well defined; a fundamental assumption of fracture mechanics is that flaws are always present. Fracture mechanics theories formulated on the basis of continuum mathematical models are based on homogeneous media, while dislocations are known to exist on the microscopic level. Consequently, it is important to re-examine fundamental assumptions. In thermodynamics, the scale of the analysis is very important since on a microscopic scale most solids are highly heterogeneous due to dislocation distributions, and would require a statistical thermodynamic analysis. However, for

most materials it is reasonable to assume that on a macroscopic scale an equivalent homogeneous continuum model can be defined [9]. The well developed principles of deterministic continuum thermodynamics can then be applied using this equivalent homogeneous model.

The quantitative relationship between micromechanics and fracture mechanics is limited. Ghonem and Provan[37] have described a probabilistic micromechanics theory of fatigue crack nucleation, crack initiation, and crack propagation. Crack motion is defined in terms of a Markovian stochastic process defining the probability distribution of fatigue. Three domains have been defined in this approach, in contrast to the traditional microscopic and macroscopic views. A microelement is defined as the basic unit of the material system, corresponding roughly to the microscopic scale. The mesodomain consists of an intermediate region considered to be spatially homogeneous, but containing a statistically large number of microelements. Finally, a macrodomain is defined as the entire material system. A macroscopic scale would be somewhere between a mesodomain and a macrodomain. References[37] and [38] are important since the analysis of stochastic processes in micromechanics is addressed.

Thermodynamic relationships involving dislocations are described in References [39], [40], [41], and [42]. Majumdar and Burns[39] used the microscopic scale of dislocations in an analysis of plasticity near a crack tip. They derived stress intensity factors from dislocation distributions. Hirth, et.al.[40] interpreted path-independent contour integrals as virtual thermodynamic forces representing the variation of the

free energy of a system with moving defects. Kelly and Gillis[41] analyzed dislocation populations to derive plastic strain rate, since plastic deformation arises from movement and generation of dislocations. Finally, Khannanov[42] used irreversible thermodynamics to characterize plasticity in creep deformation.

Tanaka and Mura[43] calculated strain energy density using a dislocation distribution giving the energy required for crack initiation. A hysteresis loop was defined and a fatigue relationship consistent with the Manson-Coffin equation was derived. Good qualitative agreement to data was described, but the generalization to fracture mechanics relationships was not provided. Although good agreement to experimental stress intensity factors was reported, the micromechanics does not permit generalization to fracture mechanics parameters at present.

The last area in this literature survey is the area of plasticity theory. The plastic strain energy is directly related to irreversible thermodynamics and is an important consideration in fracture mechanics. Plastic strain has also been quantified by accumulations of dislocation pileups. Therefore, it is necessary to consider plasticity theory as it relates to irreversible thermodynamics, fracture mechanics, and dislocation theory.

Plasticity Theory

Plastic deformation is directly related to the irreversible thermodynamics since irreversible processes are always accompanied by a non-negative entropy production.

Likewise, plastic deformation is a fundamental part of the theory of fracture mechanics since for most structural materials the high local stresses near a crack tip have a significant plastic contribution. Finally, plastic deformation is an important part of the analysis of micromechanics since movement of dislocation populations can be related to plastic deformation[44].

Reference [45] describes variational principles in plasticity and elasticity, defining unique properties of plastic deformation which complicate the analysis. First, plasticity is inherently a nonlinear theory. Second, while elastic processes usually involve well-defined mathematical functions, in many cases the plastic deformation is dependent on the loading history. This means that stress is not a unique function of strain, but also dependent on the memory of plastic deformation. Finally, although stress is a function of strain in elasticity theory, when plastic deformation is considered strain rate must also be included, as in the flow theory of plasticity.

Although some metallurgists include the phenomenon of anelasticity in the class of nonlinear processes, a simple example from dynamic systems theory provides an alternative interpretation. When a dynamic force is applied to a spring, the resulting deformation will be in phase with the applied load. When a linear dashpot is included in series with the spring, the resulting deformation will lag the applied load. This lag results in an instantaneous phase shift between force and deformation which renders them non-proportional at that instant. However, the process is linear, and the phenomenon of

anelasticity is an analogous phase shift between stress and strain at low strain levels. This phase shift is a function of the frequency of the applied load, and under sustained steady-state loading results in dissipation of energy, giving rise to a heat flux. However, this anelasticity is linear and does not involve plastic deformation.

One very simple physical model by Whiteman[46] views plastic deformation as the random frictional slip between microscopic yielding elements. This model can be used to define a local quasi-static stress-strain relationship and a hysteresis loop under cyclic loading. In most analytical approaches, plastic deformation is assumed to occur when the applied stress exceeds the yield stress. This yield stress is usually defined by the permanent offset experienced from a certain applied load, but the phenomenon of yield is not a discrete occurrence. The traditional definition of a yield surface, or plastic zone near a crack tip, assumes yield to be a discrete process. Below the yield stress the response is totally elastic, and above the yield stress the response is suddenly plastic. The random yielding model by Whiteman[46] mentioned above predicts a gradual increase in plastic deformation with increased strain. Since this approach is described in detail in the next section no further elaboration is warranted here, except to note that this simple local random yielding model has a theoretical basis in dislocation theory and provides valuable insight into fracture mechanics.

Valanis[47] has also derived a theory of plasticity without defining yielding as a discrete process. In his approach, the principles of irreversible thermodynamics are the

basis for a theory of plasticity based on the concept of intrinsic time. This intrinsic time is a function of the plastic strain increment and is assumed to be a measure of damage. Valanis[48] calls this theory of plasticity endochronic, since the intrinsic time is used to predict structural durability. This approach provides good agreement to strength data, and can be used to define a hysteresis loop and fatigue damage. The foundations in irreversible thermodynamics lends a rigorous mathematical interpretation to this approach.

Reference [14] describes another approach to plasticity based on the principles of irreversible thermodynamics, including a brief review of various theories of plasticity. Although a discrete yield state is assumed, the second law of thermodynamics is expressed by the Clausius-Duhem inequality. The relationship between the entropy state and heat flux is stated in terms of an inequality relationship, where equality corresponds to a reversible process. The inequality holds when the process is reversible, but can be reduced to an equality using the entropy production (irreversible entropy). Plasticity is described using this irreversible entropy contribution, and memory and combined work-hardening are described.

One final plasticity analysis warrants discussion here since it involves dislocation theory [49]. The plastic stress field near the crack tip is modeled by dislocation pileups on slip planes oriented along symmetric lines branching out from the crack tip. These dislocations distributions are used in the analysis of small-scale yielding, prediction of crack

opening displacements, and fatigue crack growth. The residual plasticity of prior cycles is analyzed, and a theory of crack closure is proposed.

It has been demonstrated that the analysis of fatigue and fracture phenomena is interdisciplinary, involving numerous related mechanisms. This report describes a fundamental approach to structural durability which is consistent with the principles of irreversible thermodynamics, fracture mechanics, dislocation theory, and plastic deformation. A theoretical basis for fatigue crack nucleation, initiation, and propagation is proposed, as well as fatigue crack growth under periodic loading. In the sections to follow, a local analysis of crack tip stresses and strains is described. An alternate form of the Griffith energy relationship is proposed in terms of strain energy density at the crack tip. The classical singular form of the linear stress is shown to hold for the strain, but the local stress is always finite. A hysteresis model is described which leads to crack growth identical in form to the Paris law. Therefore, a theoretical basis for the largely empirical Paris relationship is provided. Finally, a theoretical basis for crack growth under combined loading including resonance is demonstrated.

A THEORY OF FRACTURE BASED ON LOCAL RANDOM YIELDING

All materials have embedded defects to some degree, and these defects influence structural durability. Therefore in fracture mechanics cracks are assumed to be present and the critical crack size and crack growth rate are investigated. The stress near the tip of a growing crack is known to be orders of magnitude larger than the remote stress in many cases. According to the theory of linear elastic fracture mechanics, the stress at the tip of a sharp crack is singular[50]. A more precise estimate of the stress magnitude requires some consideration of crack blunting due to plasticity, but qualitative understanding can be gained through preliminary analysis of the linear stress concentration factor.

For an infinite thin sheet containing an elliptical hole subjected to a uniform remote stress, the maximum stress on the edge of the hole is [50]:

$$\sigma_{\max} = \sigma_r \left[1 + 2 \frac{a}{b} \right], \quad (1)$$

where b/a is the ratio of the ellipse minor and major axes and represents a quantitative measure of crack sharpness. For a circular hole, $\sigma_{\max} = 3\sigma_r$. As b/a approaches zero the crack becomes infinitely sharp and σ_{\max} approaches infinity. The mathematical model for local random yielding is based on the analysis by Whiteman[46] and lends insight into local yielding at a crack tip due to such large stresses. The basic element of the model is a block with a linear spring resting on a rough surface, shown in Figure 1a. When load is applied to the spring, the frictional force counteracts the applied load and

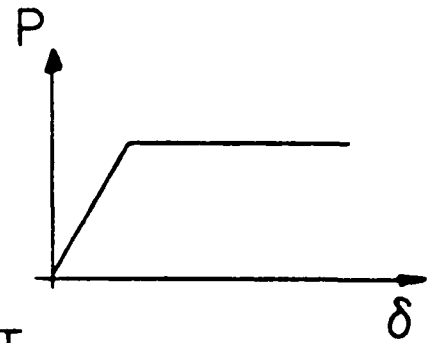
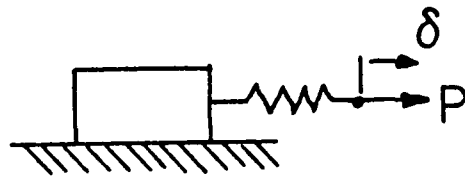

A. YIELDING MICROELEMENT

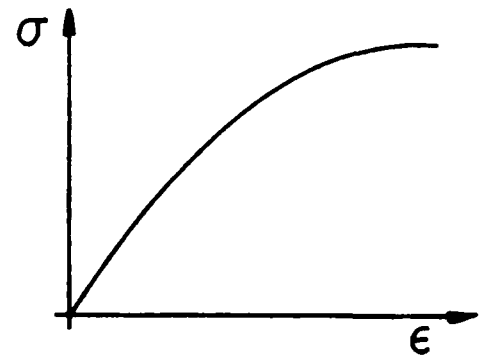
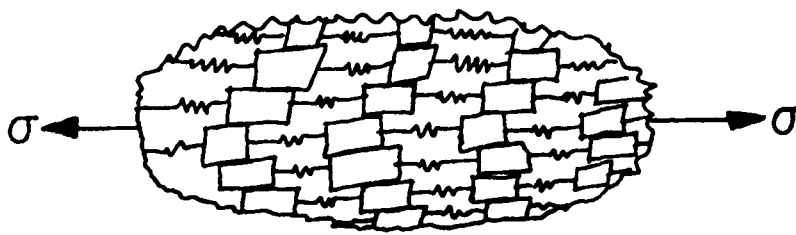

B. POPULATION OF MICROELEMENTS

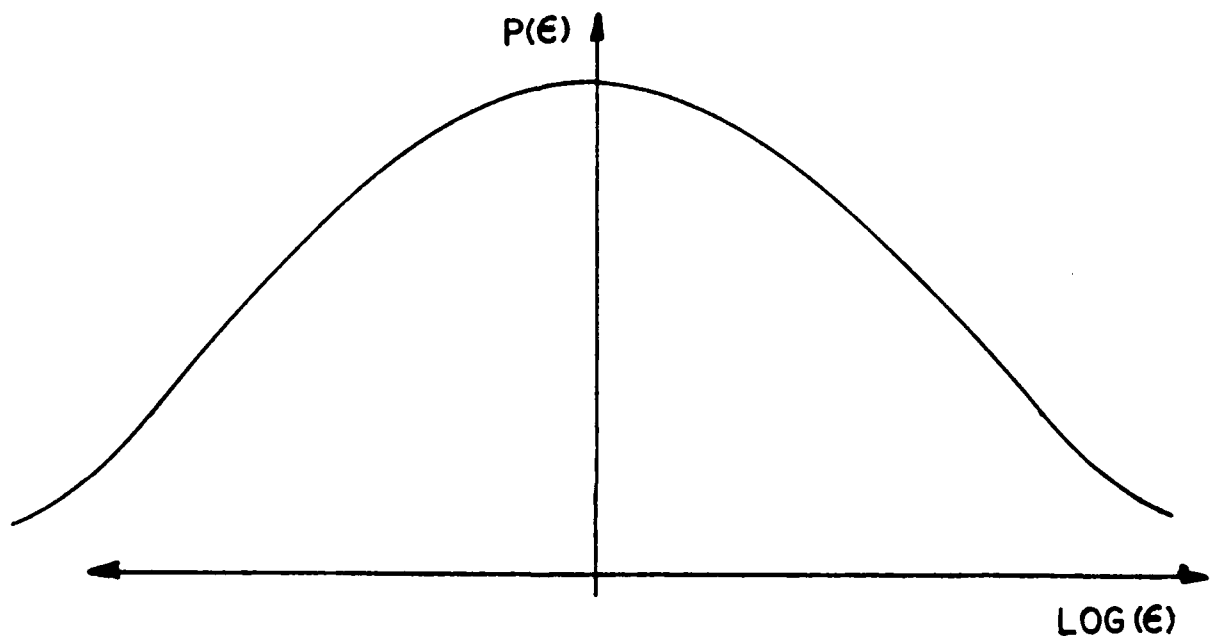

C. PROBABILITY DENSITY FUNCTION OF YIELDING

Fig. 1. Spring-Mass-Friction Infinitesimal Model for Local Random Yielding.

an elastic relationship exists until the maximum friction force is exceeded. Higher forces result in unlimited displacement giving perfectly plastic deformation. Now consider a statistically significant ensemble of such elastic-perfectly plastic elements interconnected as shown in Figure 1b, with the yield points randomly distributed. The percentage of elements yielding at a particular applied strain is characterized by the probability distribution function, $P(\epsilon)$, in Figure 1c. For small strains, very little yielding occurs and the response is elastic. For high strains, yielding occurs and the response includes plastic deformation. Whiteman[46] proposed a log-normal distribution for the plastic strain based on tangent modulus data in aluminum. When the mean log strain is zero, the mean plastic strain is unity. Thus, even though the total strain may approach infinity consistent with fracture mechanics theory, the plastic strain is finite and therefore the stress is finite. Prager[51] has also used this model as the basis for elastic-plastic stress-strain relations, although he apparently was not aware of the work by Whiteman. The probability distribution function is integrated for positive strain values only since the log function is undefined for negative arguments, and as the strain approaches zero, the log strain approaches negative infinity. Then the mean log plastic strain is zero, corresponding to unity plastic strain. Therefore, the stress is finite although the local strain may approach infinity. The log variance is σ_0 , which physically represents the amount of scatter in the plastic strain at fracture.

Consider the local yielding due to an incremental strain $d\varepsilon$ resulting in an incremental stress $d\sigma$. The elastic strain originates from those elements which have never yielded:

$$d\varepsilon_e = d\varepsilon \left[1 - \int_0^\varepsilon P(n) dn \right]$$

The plastic strain comes from those elements that have yielded:

$$d\varepsilon_p = \varepsilon P(\varepsilon) d\varepsilon$$

Since the total strain is the sum of the elastic and plastic contributions, it is possible to calculate the stress:

$$d\sigma = E(d\varepsilon_e + d\varepsilon_p)$$

Whiteman[46] derived the following equation for the local stress-strain relationship in the presence of random yielding based on these concepts:

$$\sigma = E\varepsilon \left[1 - \int_0^\varepsilon P(n) dn \right] + E \int_0^\varepsilon n P(n) dn. \quad (2)$$

Equation (2) represents the mean stress and is plotted in Figure 2, along with the total strain energy. Figure 2 shows that the local strain energy density reaches a peak at some high strain level where the stress begins to decrease rapidly because of plasticity. These relationships are to be analyzed in more detail later, but the phenomenon of cracking is described first.

Stresses and Strains Near A Crack Tip

Inglis[20] solved for the stress-strain field near an elliptical hole. This stress analysis by Inglis formed the basis for Griffith's analysis of strain energy release rate.

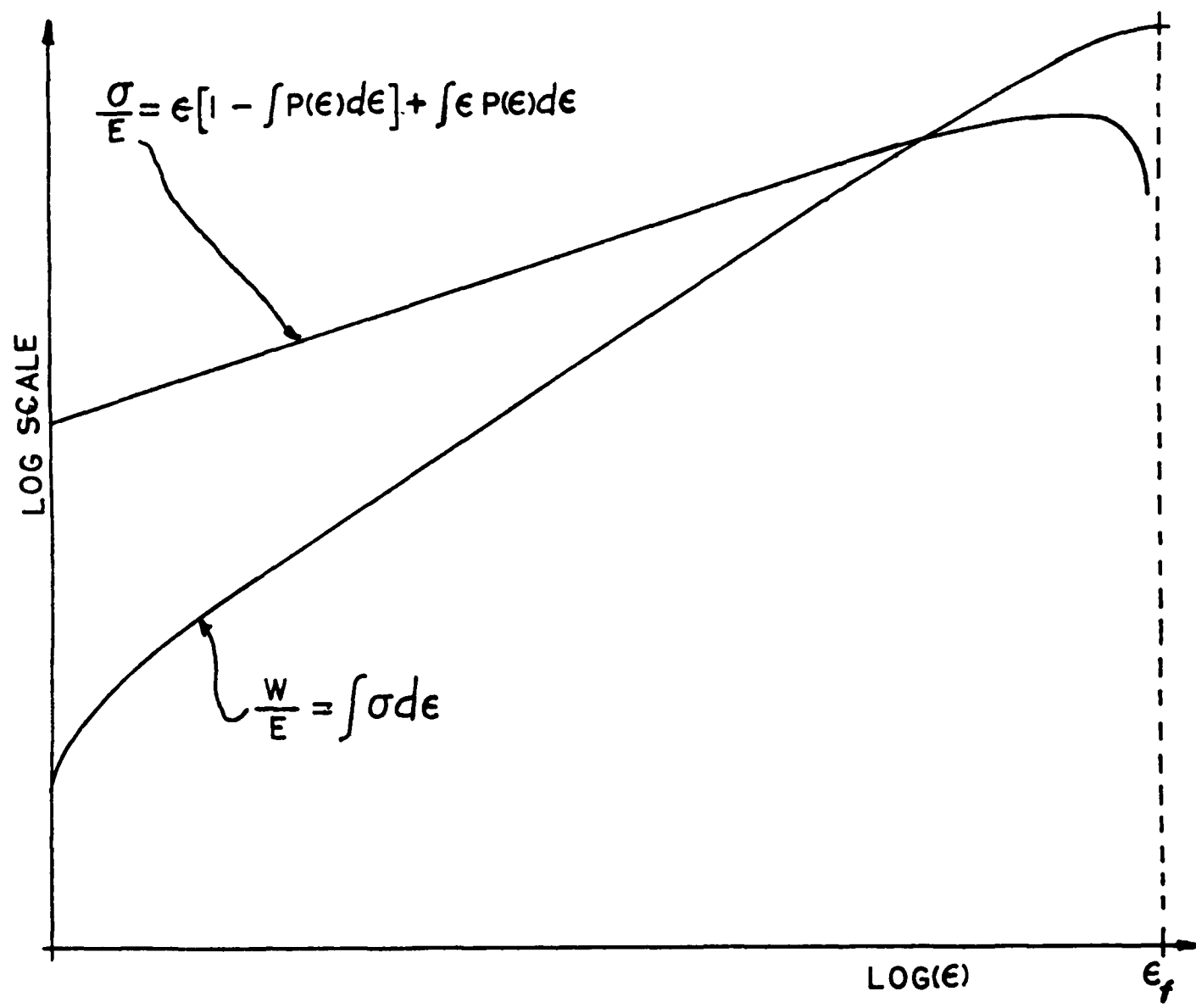

Fig. 2. Local Stress-Strain Relationship and Strain Energy Density from Local Random Yielding for High Strains Corresponding to Large Scale Yielding.

Curvilinear coordinates were used to define a family of ellipses intersecting with a family of hyperbolas as shown in Figure 3. The hyperbolas always intersect the ellipses at right angles providing a convenient way to characterize stresses and strains around an elliptical hole [52]. Using the displacement field given in Reference [53], the displacement gradient at the surface of the hole is:

$$\frac{\partial u}{\partial \xi} = \frac{\sigma_r^c}{E} \sinh 2\xi \frac{(\cosh 2\xi + \cosh 2\xi_0 - \cos 2\nu)}{(\cosh 2\xi - \cos 2\nu)^2} \quad (3)$$

In equation (3), σ_r is the applied stress far away from the hole, and ξ_0 is the curvilinear coordinate defining the hole surface. When ξ_0 approaches zero, the Griffith crack is defined.

The maximum stress always occurs at the ends of the major axes of the elliptical hole [52], so for purposes of this analysis of crack tip stress and strain, $\nu = 0$. The strain then increases as the distance to the hole is decreased, consistent with linear elastic fracture mechanics; for elastic deformation, crack tip stresses are singular according to the inverse square root of the distance to the crack tip. Combining the stress function given by equation (2) with the displacement gradient given by equation (3), the stress and strain are plotted against distance from the crack tip in Figure 3. Although for the local random yielding model the strain is singular at the crack tip for an infinitely sharp crack, the stress is always finite. For blunt cracks corresponding to large b/a , the crack tip strain and stress decrease as shown in Figure 3.

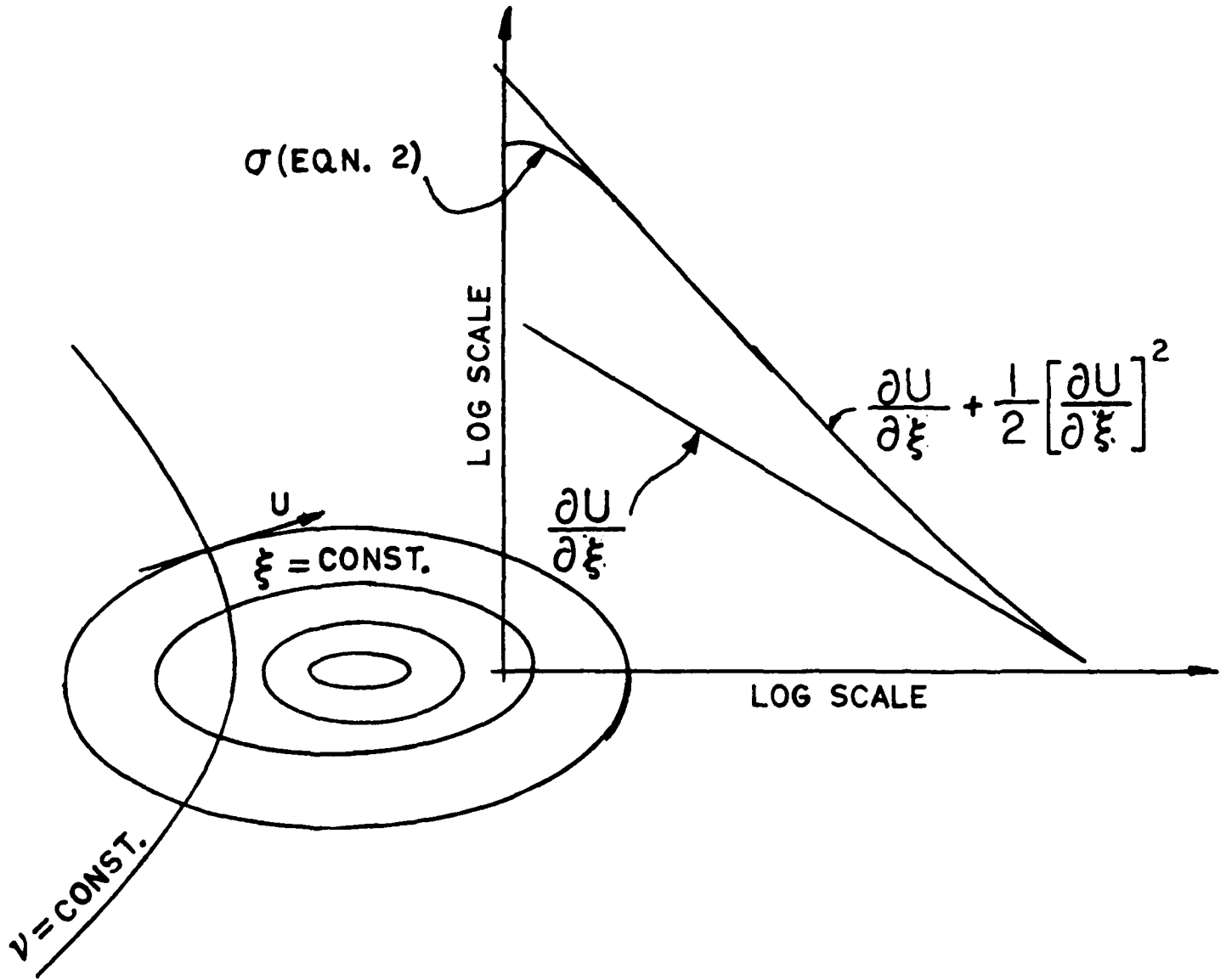

Fig. 3. Stresses and Strains by Local Random Yielding Near an Elliptical Hole in an Infinite Thin Sheet.

A Local Criterion for Crack Extension

The Griffith criterion for crack growth is that the strain energy release rate during crack extension balances the decrease of surface traction [21]. Figure 2 includes a plot of the local strain energy density and reveals a peak at high strains. This peak corresponds to the maximum local strain energy density without local unstable crack growth, since higher strains cause a decrease of strain energy density, an unstable condition. Therefore the local random yielding model includes a criterion for local stability. The maximum stable strain is calculated by setting the derivative of the crack tip strain energy density to zero:

$$\left. \frac{\partial W}{\partial \varepsilon} \right|_t = 0 \quad (4)$$

Note the distinction between equation (4) and the Griffith Criterion. Equation (4) is a local condition resulting from random yielding. The stability is characterized by taking the second derivative:

$$\left. \frac{\partial^2 W}{\partial \varepsilon^2} \right|_t \begin{array}{l} > 0, \text{ local minimum} \\ = 0, \text{ inflection point} \\ < 0, \text{ local maximum.} \end{array} \quad (5)$$

The condition that the derivative is zero and the second derivative is negative therefore represents a necessary and sufficient condition for local crack extension. This local relationship supplements the Griffith criterion, which has been demonstrated to be a necessary condition [13]. Note that a local crack growth does not necessarily imply global catastrophic fracture.

In Figure 4, the above necessary and sufficient conditions are used to predict fracture as a function of crack length compared with linear elastic fracture mechanics. Figure 4 includes different values for b/a , which represents the sharpness of the crack. For small b/a , the crack is very sharp, corresponding to a very brittle material. Recall that for the Griffith crack $b/a = 0$, and the crack tip strain is infinite. For large values of b/a , the crack is blunt because of yielding at the crack tip. If the crack tip is sharp enough the maximum strain energy density occurs away from the crack tip, and the unstable crack will grow and the crack will blunt until the minimum stable length is reached. If the crack tip is blunt enough, the local maximum strain energy density is never reached and that particular crack length and remote stress are stable. Figure 4 shows the combinations of remote stress and crack length where the maximum local strain energy density occurs at the crack tip. Note that some particular critical value of b/a provides consistent agreement with linear elastic fracture mechanics, while others indicate more or less crack tip plasticity.

The result summarized in Figures 3 and 4 is consistent with the principles of irreversible thermodynamics. The principle of maximum entropy production states that the stable equilibrium condition is one for which the entropy production is maximized[11]. The entropy gain during quasi-static fracture can be calculated from the plastic part of the strain:

$$S_f = \int_c^{\epsilon} \sigma d\epsilon_p / \theta \quad (6)$$

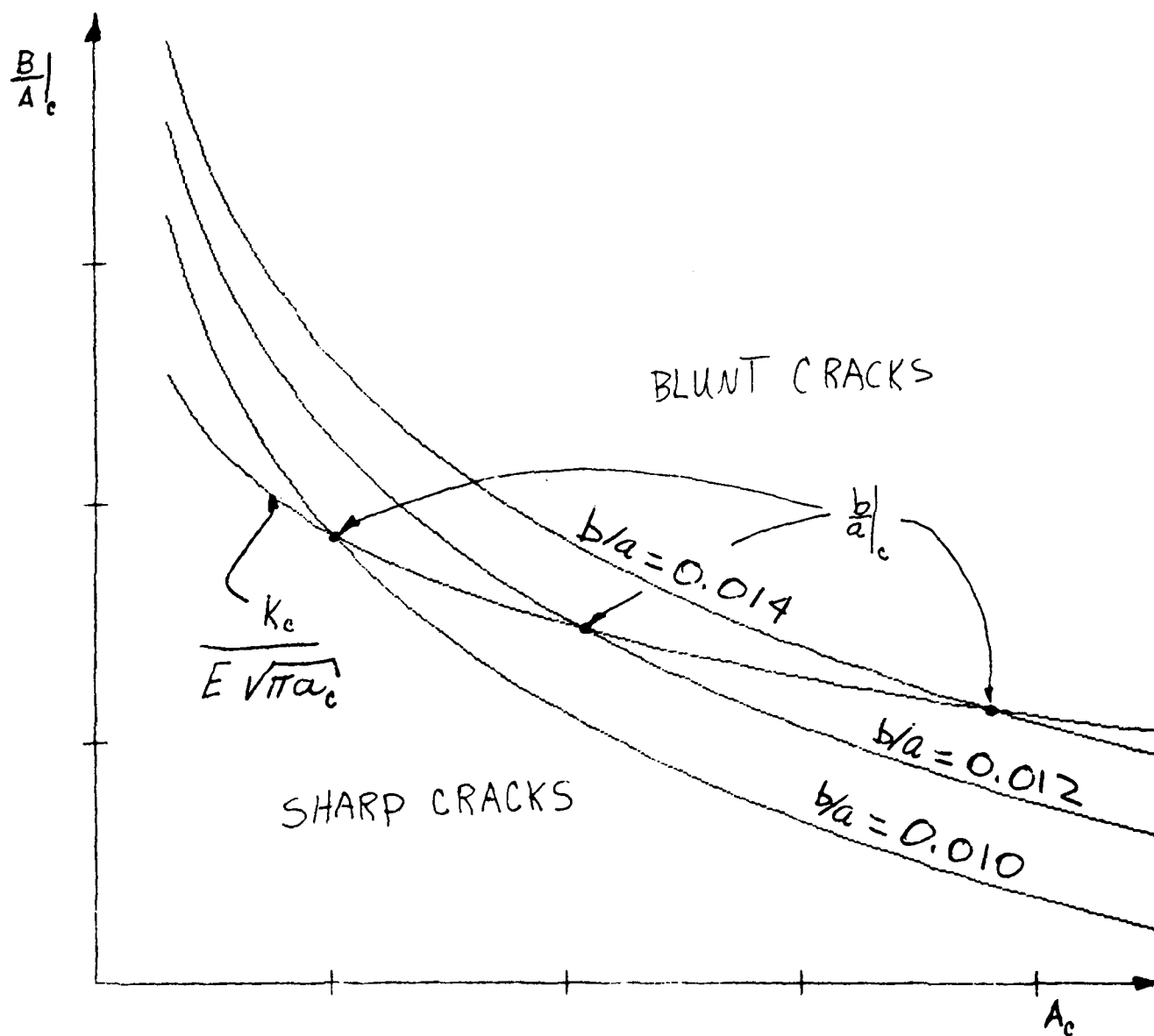

Fig. 4. Critical Stress Versus Critical Crack Length for Various Crack Sharpness During Local Random Yielding.

The principle of maximum entropy production is therefore equivalent to the above stability criterion for isothermal, quasi-static fracture. The peak in the strain energy density curve occurs at some high strain, ϵ_f , which is constant for a particular material. Furthermore, the entropy gain for the quasi-static fracture under isothermal conditions is a constant.

Reference[30] describes an energy balance during fatigue crack growth. The assumption is offered that if a propagating crack is stable, then the crack extension may be close to a reversible one. This assumption appears at first to be contradictory since crack growth is an irreversible thermodynamic process and therefore must be accompanied by an entropy gain, but when the relative values of the energy terms are considered the contradiction is resolved. Certainly crack extension is irreversible, but the primary energy transfer can be approximated by the local energy release at the crack tip and the corresponding decrease in strain energy of the material. Reference[36] has verified that there is a high concentration of energy transfer at a crack tip through measurements of very high local temperatures at the crack tip.

The mathematical model for crack tip plasticity has been demonstrated to provide results consistent with linear elastic fracture mechanics. Figure 4 demonstrates that for some value of b/a , the necessary and sufficient conditions for local crack growth given by equations (4) and (5) agree with the fracture toughness predicted by linear elastic fracture mechanics. However, Figure 4 shows that b/a would be variable, since crack blunting due to plasticity at the tip retards crack growth.

The next section quantifies the crack tip bluntness function during quasi-static, isothermal fracture.

Fracture Toughness and Crack Blunting

The Griffith criterion was originally developed for brittle materials and sharp cracks, giving erroneous results for ductile materials and blunt cracks[21]. It is well-known that crack tip plasticity has the effect of blunting the crack and retarding crack growth[21]. This mathematical model for local yielding can be utilized to quantify that blunting relationship. Figure 4 has established that constant crack bluntness, b/a , gives a curve which intersects the critical stress curve at some crack length. Furthermore, Figure 4 demonstrates that as the remote stress increases and the critical crack length decreases, the crack tip becomes sharper since b/a decreases. It is therefore possible to solve for the crack tip bluntness as a function of crack length which corresponds to the fracture toughness shown in Figure 4.

Figure 5 is a plot of the critical value of crack tip bluntness, $b/a|_c$, required to make equations (4) and (5) predict local unstable fracture in agreement with linear elastic fracture mechanics for various different values of fracture toughness. The functional relationship between critical crack sharpness, critical crack length, and fracture toughness based on Figure 5 is:

$$\frac{b}{a}|_c = C_0 [K_c]^{0.5} a^{0.25}, \quad (7)$$

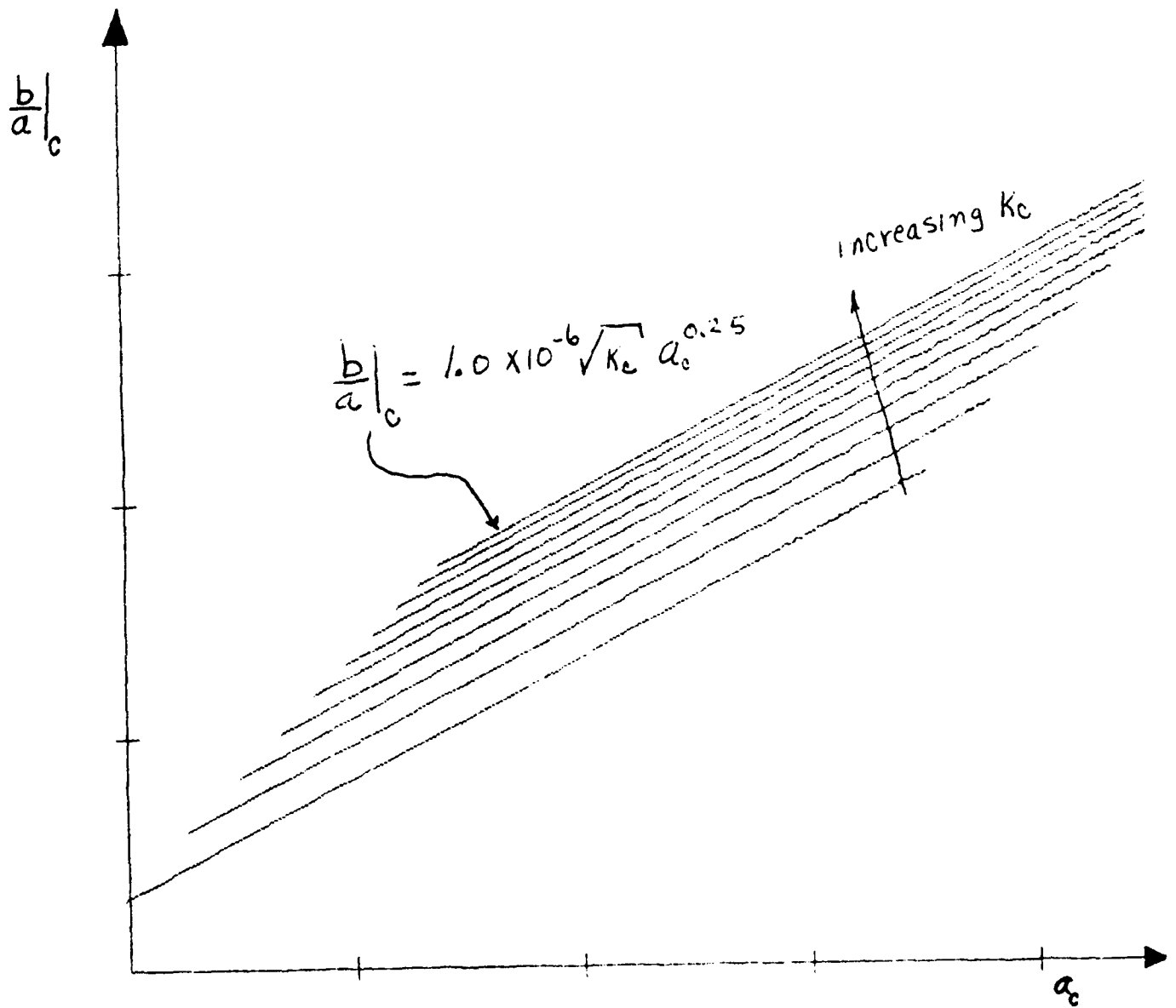

Fig. 5. Variation of Critical Crack Tip Bluntness With Critical Crack Length.

Figure 5 provides qualitative insight into the mechanism of crack extension. For sharp cracks, the crack tip yielding is less stable and cracks are more likely to grow. For blunt cracks, yielding at the crack tip is diminished since

$$\frac{\partial W}{\partial \epsilon} > 0$$

and the crack extension is stable. That is why large transient overloads retard crack growth; there is a local increase in crack tip plasticity causing the crack to be blunted and increasing b/a . The influence of low-level cyclic loading appears to be one of sharpening the crack: that is, decreasing b/a until the crack tip is sharp enough for unstable crack growth.

The relationship between crack blunting and critical crack length includes two physical processes: first, the fracture toughness is a material constant which characterizes the ductility of the material. Second, the loading history affects crack bluntness as the material remembers large transient overloads. The constant C_0 contained in equation (7) would be determined on the basis of fracture toughness data as shown in Figure 5. The standard deviation of random plastic strain, σ_0 , is the other parameter to be determined from data. Whiteman [46] used tangent modulus data to model the random yielding as log-normal. A new mathematical model for material damping can also be used to determine σ_0 and forms the basis of the analysis of fatigue and fracture during cyclic loading. This new material damping model is described in the next section.

INTERNAL FRICTION BASED ON LOCAL RANDOM YIELDING

The mathematical model for local random yielding has been applied to cyclic loading, resulting in an equation for the hysteresis loop for high strains which includes a significant plastic contribution[46]. In Reference '54', the anelasticity of low strain levels is included with Whiteman's analysis and parameters for log-normal plastic strain distribution are selected for aluminum. For low strain amplitudes with no cracking good agreement to fatigue data is presented by defining local failure as the exceeding of a critical irreversible entropy threshold of fracture. In this section the theory is extended to the crack problem by considering oscillation about some large static strain.

Hysteresis Damping from Dynamic Plastic Strain

Consider loading up to some strain ϵ_0 in Figure 6a. Those elements which have yielded impose a compressive stress on adjacent elements upon unloading and no more yielding would take place until ϵ_0 is subsequently exceeded. This property of the model defines the memory of the plastic deformation. The probability structure is changed by the yielding and loading in compression causes tensile yielding. The mean dynamic plastic strain amplitude under cyclic loading is therefore:

$$E[\epsilon_p] = \int_{-\epsilon_s}^{\epsilon_s} \left(\frac{\eta+\epsilon}{2}\right) P\left(\frac{\eta+\epsilon}{2}\right) d\eta. \quad (8)$$

Since negative strains are not defined for the log-normal distribution, no further yielding can occur in compression, no matter how ϵ_0 changes. This shift of the probability structure

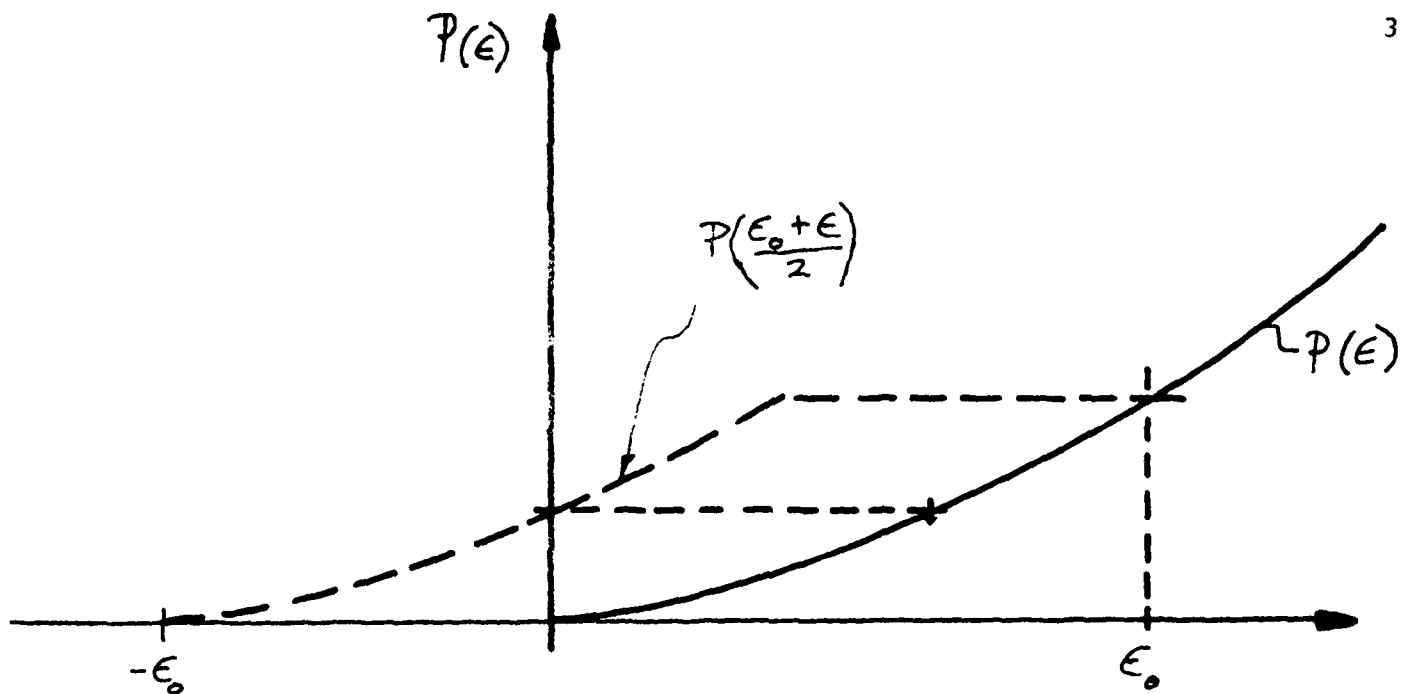

a. Change in Probability Structure Due to Yielding.

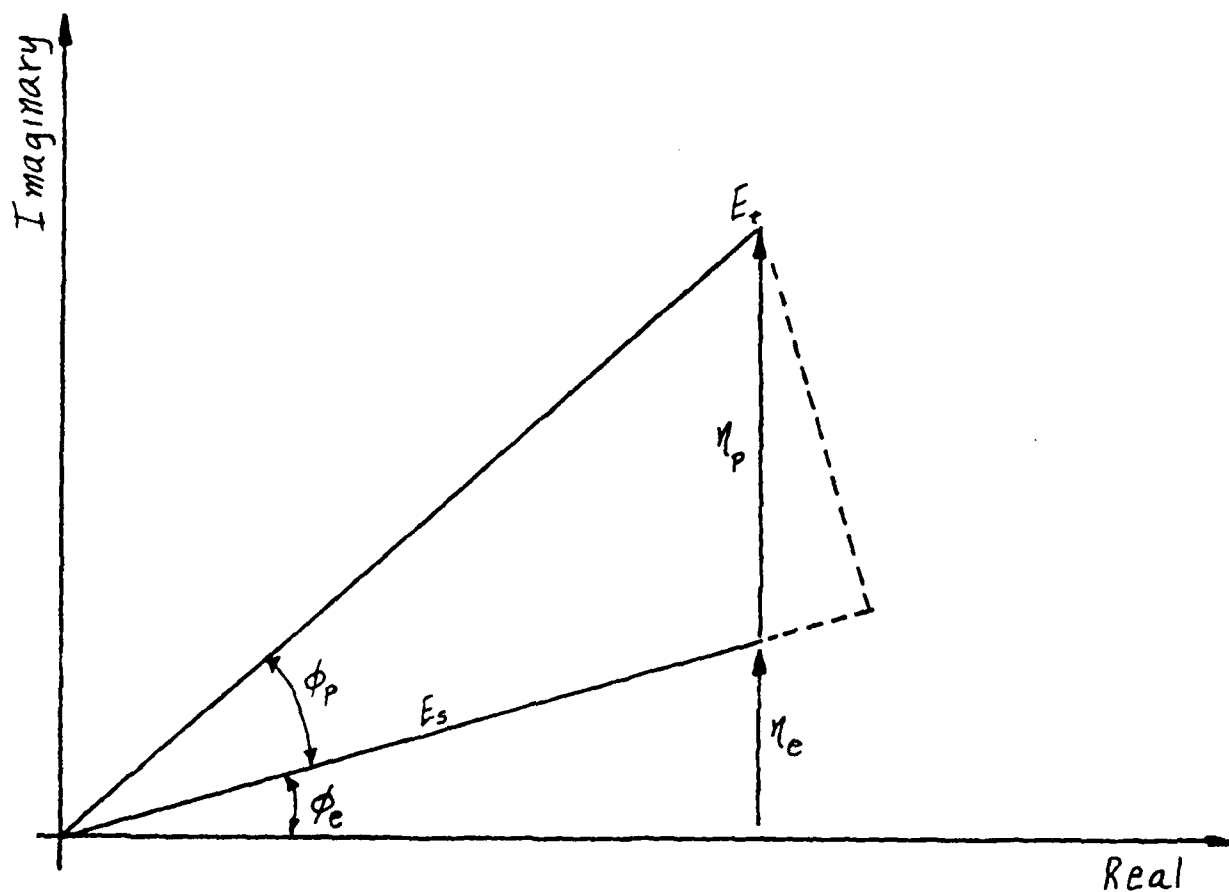

b. Definition of Loss Factor from Complex Modulus.

Fig. 6. Definition of Loss Factor Defined by Dynamic Tangent Modulus from Local Random Yielding Under Cyclic Load.

during fatigue represents a retardation mechanism. A large overload inhibits any further yielding until a subsequent higher overload occurs or the crack tip becomes sharper as fatigue damage accumulates to the critical irreversible entropy level.

Figure 6a indicates the probability distribution function of plastic strain including the maximum previous strain ϵ_0 , and some sinusoidal strain amplitude ϵ_s . When a cyclic load of amplitude $\epsilon_s = \epsilon_0$ is applied, the hysteresis loop defined by Whiteman [46] results, as well as the loss factor of Reference [55]. The storage modulus, which is the in-phase component of the dynamic strain is:

$$E_s = E \left[1 - \int_{-\epsilon_s}^{\epsilon_s} P\left(\frac{\eta + \epsilon_s}{2}\right) d\eta / 2 + \int_{-\epsilon_s}^{\epsilon_s} \eta P\left(\frac{\eta + \epsilon_s}{2}\right) d\eta / 2E \right] \quad (9)$$

When subsequent loads are applied, the previously yielded elements are in compression, and energy is expended in deforming back to the original position. This contribution to the hysteresis energy is the irreversible entropy contribution, since it is a function of microplastic deformation. Large transient overload significantly increases the plastic zone, putting the region near the crack tip into compression, and retarding crack growth due to the energy required to overcome the compressive strains.

The loss factor derived in Reference [54] is a critical part of this analysis so is summarized here. The storage and loss moduli can be used to express the dynamic stress-strain relationship and are represented on the complex plane in Figure 6b, where large transient loads may affect the tangent modulus

because of yielding [46]. Therefore, the storage modulus under large cyclic loads is:

$$E_s = [1 - \int_0^{\epsilon_0} P(n)dn] [1 - \int_{-\epsilon_s}^{\epsilon_s} P(\frac{n+\epsilon_0}{2})dn / 2 + \int_{-\epsilon_s}^{\epsilon_s} n P(\frac{n+\epsilon_0}{2})dn / 2\epsilon_s] \quad (10)$$

Typical loss factor data for aluminum along with values for σ_0 are presented in Figure 7b[55]. Loss factor is related to the storage modulus according to:

$$\eta_s = [1 + \eta_e^2 - E_s^2]^{0.5} \quad (11)$$

Excellent agreement to data is indicated by fitting just one parameter, the variance of random yielding, σ_0 .

The parameter η_e in equation (11) is the anelasticity term representing internal friction at low strain levels. This component is not related to the plastic strain and is not a function of the strain level. Rather, it is a function of the frequency and is physically related to the diffusion process [56]. Figure 7a is a plot of low-strain loss factor versus frequency, and can be related to the activation energy and temperature. From Figure 7a,

$$\eta_e = \eta_0 (f/f_1)^Y$$

Now from Reference [56], the temperature and frequency dependence are related by:

$$U_0 = [1/\theta_2 - 1/\theta_1] = \log\{f_2/f_1\}$$

Therefore the frequency dependence of the loss factor indicated in Figure 7a is equivalent to the temperature dependence of activation energy.

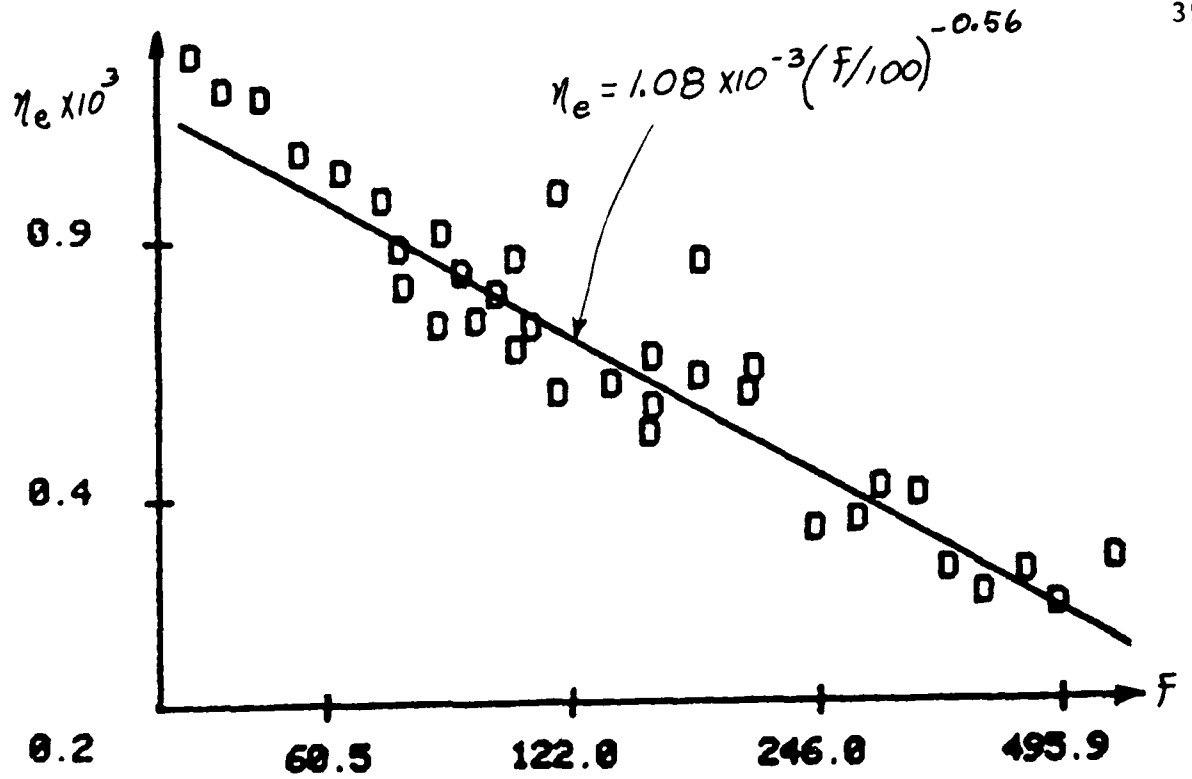

a. Loss Factor as a Function of Frequency.

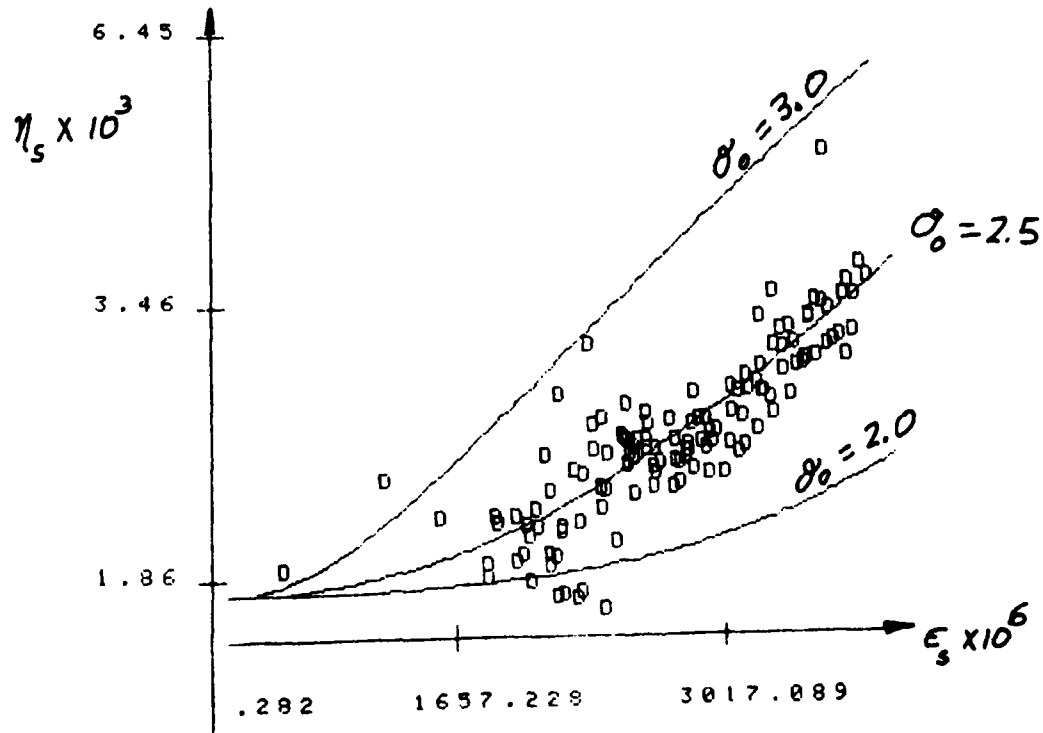

b. Loss Factor as a Function of Strain Amplitude.

Fig. 7. Loss Factor as a Function of Frequency and Strain Amplitude for Local Random Yielding in Aluminum.

A Model For Fatigue Crack Nucleation

The irreversible thermodynamic analysis of local failure under cyclic loads is summarized in Figure 8. The critical irreversible entropy threshold of isothermal fracture given by equation (6) is a constant at the peak strain energy which has been demonstrated to be a necessary and sufficient condition for crack extension, and consistent with the well-known principle of maximum entropy production. In the case of sinusoidal loading, the irreversible entropy density per cycle is derived from elastic and plastic strain combined in parallel as indicated in Figure 8:

$$\frac{ds}{dN} = \frac{\pi E_t \eta_s \epsilon_s^2}{\theta} [\Delta \epsilon_p / \epsilon_s] \quad (12)$$

Then for cyclic loading the irreversible entropy rate is integrated until the entropy exceeds the critical entropy threshold, which is the same criterion for critical crack length demonstrated in Figure 5.

Combining equations (6) and (12), the number of cycles required for the local entropy gain to exceed the critical entropy threshold is defined:

$$\pi E_t \eta_s \epsilon_s^2 [\Delta \epsilon_p / \epsilon_s] N_f = S_f \quad (13)$$

Figure 8 includes a plot of ϵ_s against N_f and resembles the well-known S-N diagram with two notable exceptions: First, local strain level is indicated versus cycles to failure rather than remote stress levels. Second, failure is defined as the initiation of growth of cracks on the order one micron representing a prediction of crack nucleation[54]. For very

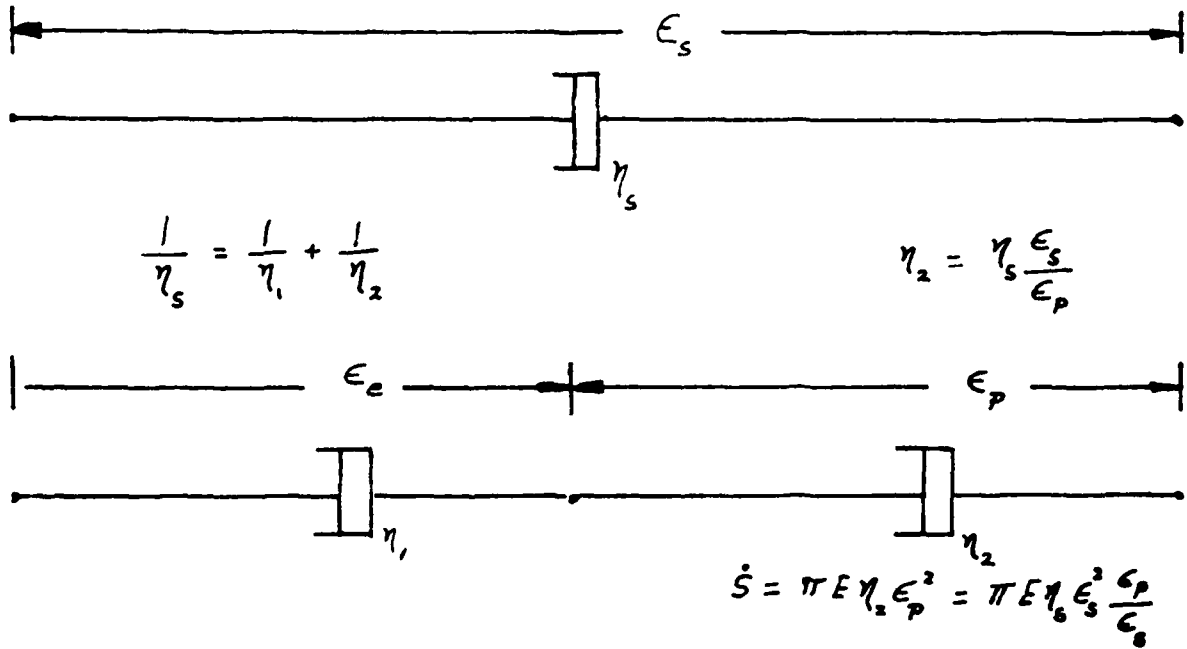

a. Parallel Dashpot (Common Stress) Representation of Entropy Gain

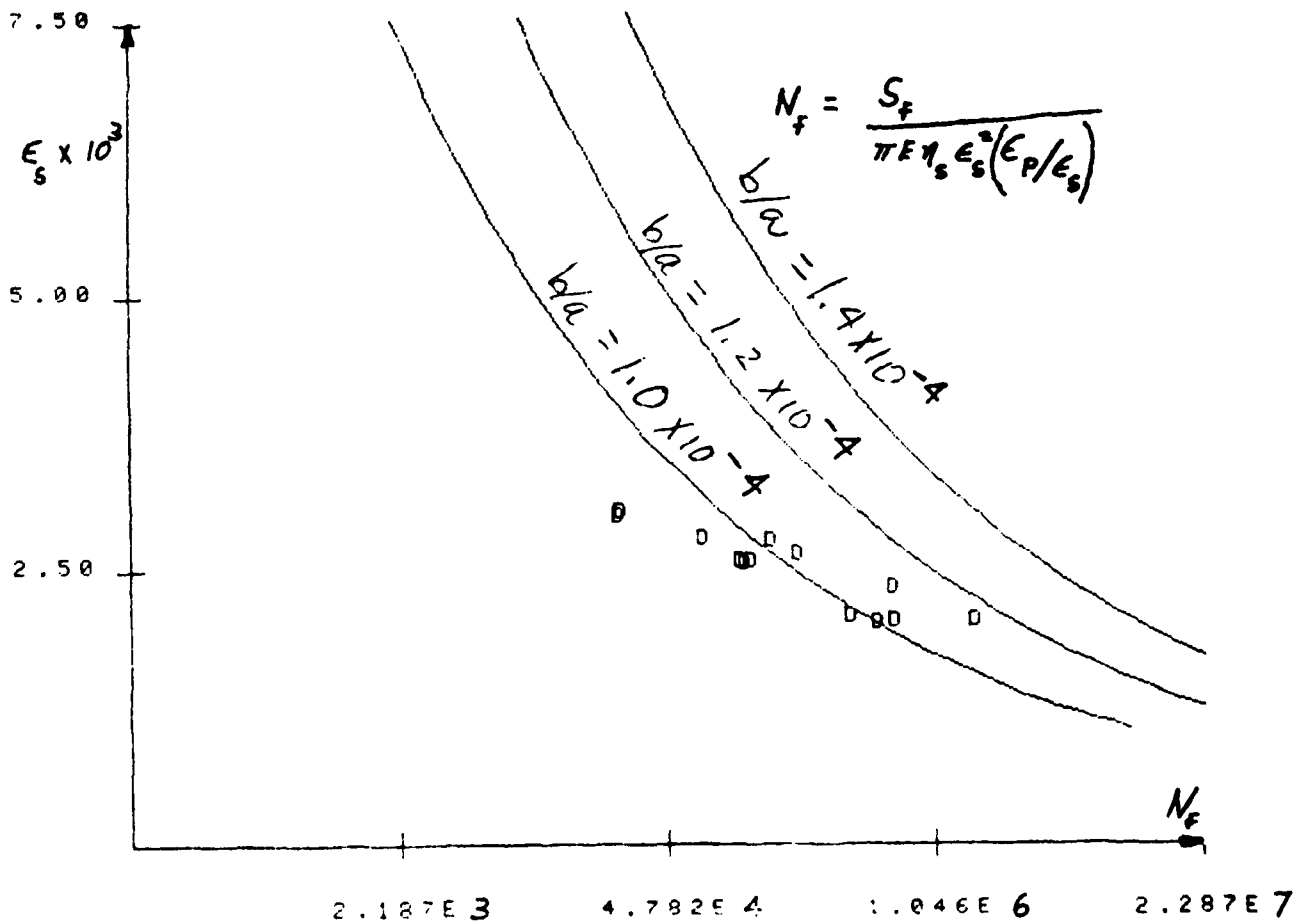

b. Crack Nucleation Lifetime Base on Critical Entropy Threshold for Various Crack Sharpness.

Fig. 8. Crack Nucleation Lifetime for Small Cracks and Different Values of b/a.

small, sharp cracks, linear elastic fracture mechanics does not apply, since the initial crack size can be arbitrarily small and plastic deformation would dominate[50]. The critical entropy threshold of local yielding provides a theoretical prediction of local breakage of molecular bonds giving the sudden appearance of a microscopic crack where no crack previously existed.

The data indicated in Figure 8 were collected on initially crack-free base-excited cantilever beams driven at resonance while enclosed in a vacuum chamber [55]. In this way, the undesirable influence of dissipation due to viscous damping in air was eliminated. The fatigue test was stopped when the resonant frequency decreased by a small amount, usually about one percent. After such a small decrease in resonant frequency, a very small crack was just visible at the base of the cantilever beam where the strain amplitude was maximum. Crack bluntness of $b/a = 10^{-4}$ provides good agreement to the experimental data and represents the formation of a crack in previously unblemished specimens.

Thus far the mathematical model for local random yielding has been demonstrated to be consistent with fracture mechanics theory, including a function for crack tip blunting due to plasticity. In addition, the mathematical model for local random yielding forms the basis for a new model of hysteresis damping. Agreement to loss factor data by selecting just one parameter is demonstrated. The model also provides a prediction for the sudden appearance of a crack. In the next section, subcritical crack growth rate under cyclic loading is analyzed.

CRACK GROWTH DURING CYCLIC LOADING

In the theory of fracture mechanics, energy transfer during local yielding at a crack tip has been characterized by the stress intensity factor for linear elastic materials. The stress intensity factor is a parameter which defines the local increase in stress at a crack tip, and for linear systems is directly and uniquely related to the strain energy release rate. When there is significant plastic deformation at the crack tip, this relationship between stress intensity factor and strain energy release rate is no longer valid. The J-integral is usually used to investigate the effect of plastic deformation, but with limited success since the plastic energy release is not concentrated at the crack tip. An alternate approach to crack growth is described here, where local yielding at a crack tip is analyzed. The local random yielding model can be used to keep track of the plastic deformation history of every point near the crack tip.

The analysis of crack extension during cyclic loading has been based on the stress intensity factor range in the theory of fracture mechanics. However, the effect of mean stress is still not adequately described, nor is the influence of resonance or combined loading. In this research, the local random yielding model of plasticity was used to derive a local hysteresis relationship for crack nucleation based on irreversible thermodynamics.

The local strain energy per unit volume at a crack tip can be calculated using equations (1) - (3), including both elastic and plastic contributions. Equations (4) and (5) represent necessary and sufficient local conditions for a crack to grow

under quasi-static conditions. The strain energy density is a constant at local yielding as is the entropy defined by the plastic part of the strain energy. For cyclic loading, there is still some irreversible energy transfer quantified by the plastic deformation. As a crack grows by some infinitesimal amount, the strain energy density at the crack tip changes. Rice [28] has quantified the irreversible energy release rate as the difference between the Irwin energy release rate and the elastic energy required to separate the crack surfaces. The entropy production was defined by the product of this difference and the crack growth rate. This is equivalent to the rate of change of the local strain energy density, W , at the crack tip where:

$$W = \int_0^{\epsilon} \sigma d\epsilon . \quad (14)$$

For cyclic loading, the energy release per cycle of loading is:

$$\frac{\partial W}{\partial a} \frac{\partial a}{\partial N} = \theta \frac{\partial S}{\partial N} \quad (15)$$

Equation (15) is based on the relationships postulated by Bodner, et.al. in a technical note [29] and Sih and Moyer[57]. Since the plastic deformation also quantifies the local entropy production, equation (15) is an entropy balance which says that the local irreversible entropy gain caused by accumulations of plastic deformation is absorbed in the crack growth mechanism. Equation (15) is equivalent to the second law of thermodynamics as defined by Gurtin [27].

Now substituting equation (12) into equation (15), the crack growth relationship is:

$$\frac{\partial a}{\partial N} = \frac{\pi E \eta_s \epsilon_s^2 [\Delta \epsilon_p / \epsilon_s]}{\partial W / \partial a} \quad (16)$$

Equation (16) is a theoretical crack growth relationship which can be calculated on the basis of two physical constants. The variance of random yielding, σ_0 , is selected on the basis of loss factor data collected in vacuum [55] or tangent modulus data [46]. The crack sharpness, b/a , is determined from fracture data as summarized in Figure 5.

For the case of small plastic deformation, $\partial W / \partial a \cong K_I^2 / E$, and equation (16) can be reduced to:

$$\frac{da}{dN} = \frac{\eta_s \epsilon_s^2 [\Delta \epsilon_p / \epsilon_s]}{\epsilon_r^2 a} \cong \Delta K_I^m$$

where ϵ_r is the strain level far away from the crack. When the strain level is low enough, $\Delta \epsilon_p$ approaches zero and the existence of a threshold crack is indicated. Crack sharpness is implicitly included in the local strain level, ϵ_s , and damping, η_s . For intermediate loading, the loss factor and plastic strain fraction can be approximated by powers of sinusoidal strain level, and the crack growth per cycle can be expressed by stress intensity factor raised to the power m .

Equation (7) quantifies the dependence of $b/a|_c$ on K_c as demonstrated in Figure 5, where $C_0 = 1.0 \times 10^{-6}$. For most engineering applications the loading would be much less than the critical level, and crack growth from subcritical loading is needed. From Figure 5, with $a_c = \text{constant}$, it is clear that:

$$\frac{b}{a} = \frac{b}{a}|_c [\sigma_c/\sigma]^{0.5} \quad (17)$$

Equation (17) is a mathematical model for the increasing sharpness of cracks as load increases. When the stress is equal to the critical stress, the critical crack sharpness results. For low stress, the crack becomes blunt since b/a increases. In the case of large transient overloads, σ_c represents the maximum stress of the load history and equation (17) quantifies the crack blunting and resulting retardation of crack growth. Equation (17) is a statement of stability margin: for subcritical stresses, the lower the stress, the blunter the crack tip, and the more stable the resulting crack growth. The effect of the blunt crack for stresses below the critical stress is to increase the slope of da/dN since crack bluntness retards crack growth.

Figure 9 is a plot of crack growth rate as a function of ΔK_I for various values of fracture toughness. Figure 9 is a significant result of this research since it represents crack growth in the presence of cyclic loading as a function of fracture toughness on a theoretical basis. Figure 9 yields an intermediate exponent of $m = 4.87$, comparing favorably with the typical form of the Paris crack growth law.

Growth of Small Cracks

Thus far a theoretical basis for crack propagation and nucleation has been postulated. Figure 8 indicates the number of cycles required to initiate growth of cracks on the order of one micron, and Figure 9 describes growth of large cracks. The mechanism of growth of very small cracks involves significant

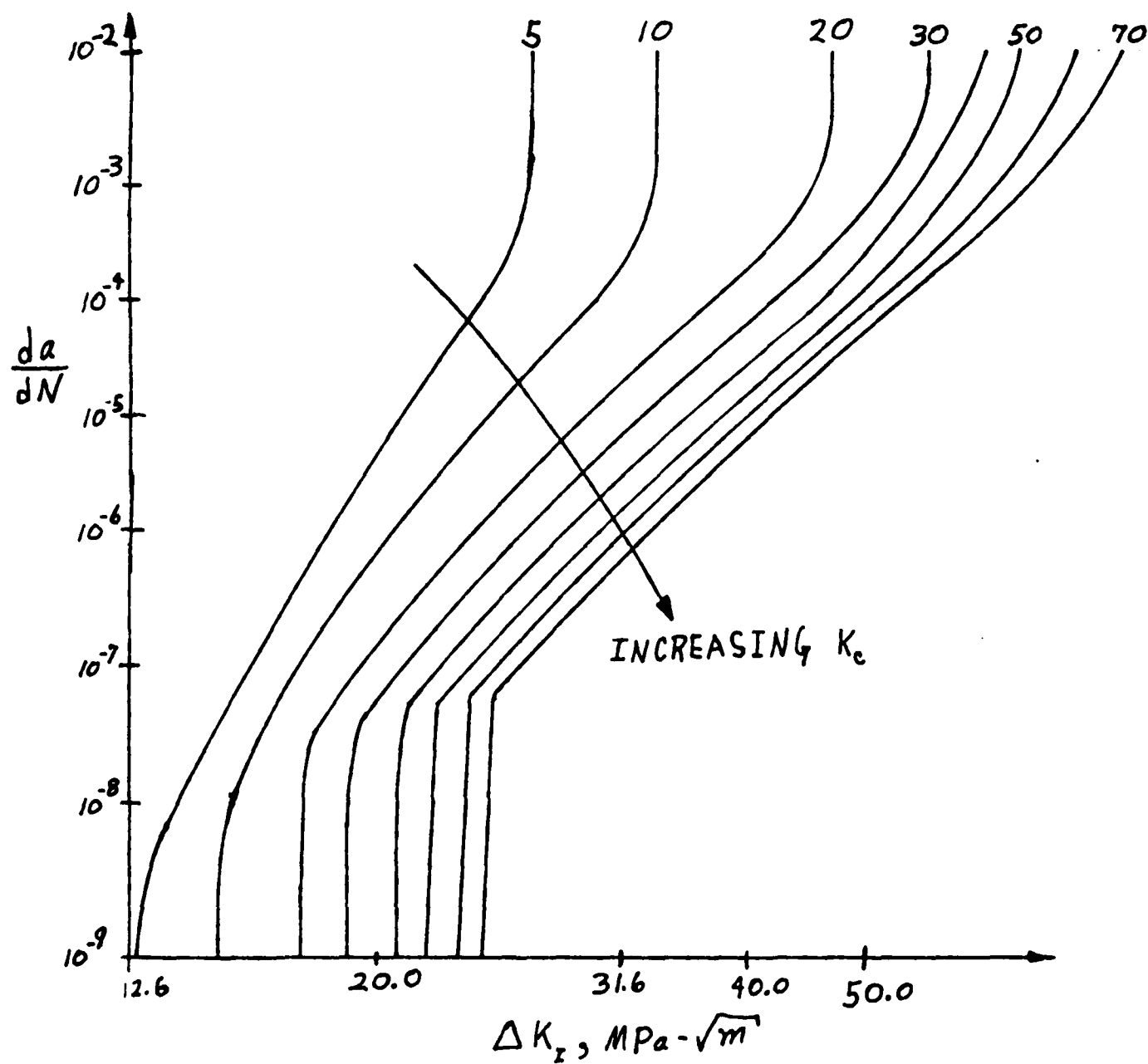

Fig. 9. Crack Growth Rate During Cyclic Loading Versus Stress Intensity Amplitude for Different Fracture Toughness.

plasticity and the crack bluntness can be modified accordingly. The growth of such small cracks has a practical application in turbine engines where very small cracks might escape inspection, but subsequently grow to critical size. The comparison to linear fracture mechanics implies the crack sharpness relationship indicated in equation 7. For very short cracks, plasticity effects would not be negligible, and deviation from linear theory would be expected.

Figure 10 is a plot of crack growth rate for various small cracks. The logarithm of critical crack sharpness was modified to vary quadratically with the logarithm of critical crack length as shown in the insert of Figure 10. This assumption is logical since the singular form of the crack tip strain changes for very short cracks. The trends outlined in References [58], [59], and [60] are substantially reproduced. Figure 10 shows both an increased crack growth rate for small cracks, and the existence of a threshold which is dependant on fracture toughness. Equation (16) substantiates the theoretical basis for a threshold, since the plastic strain fraction goes to zero as applied load goes to zero. The significance of Figure 10 is that very short cracks involve substantial plastic deformation and therefore grow much faster than predicted by linear theory.

Influence of Loading Order

The fracture criterion based on local random yielding provides results consistent with well-known results in linear elastic fracture mechanics. It is clear that crack blunting is an important mechanism during crack growth since the growth of blunt cracks is known to be lower than that of sharp cracks.

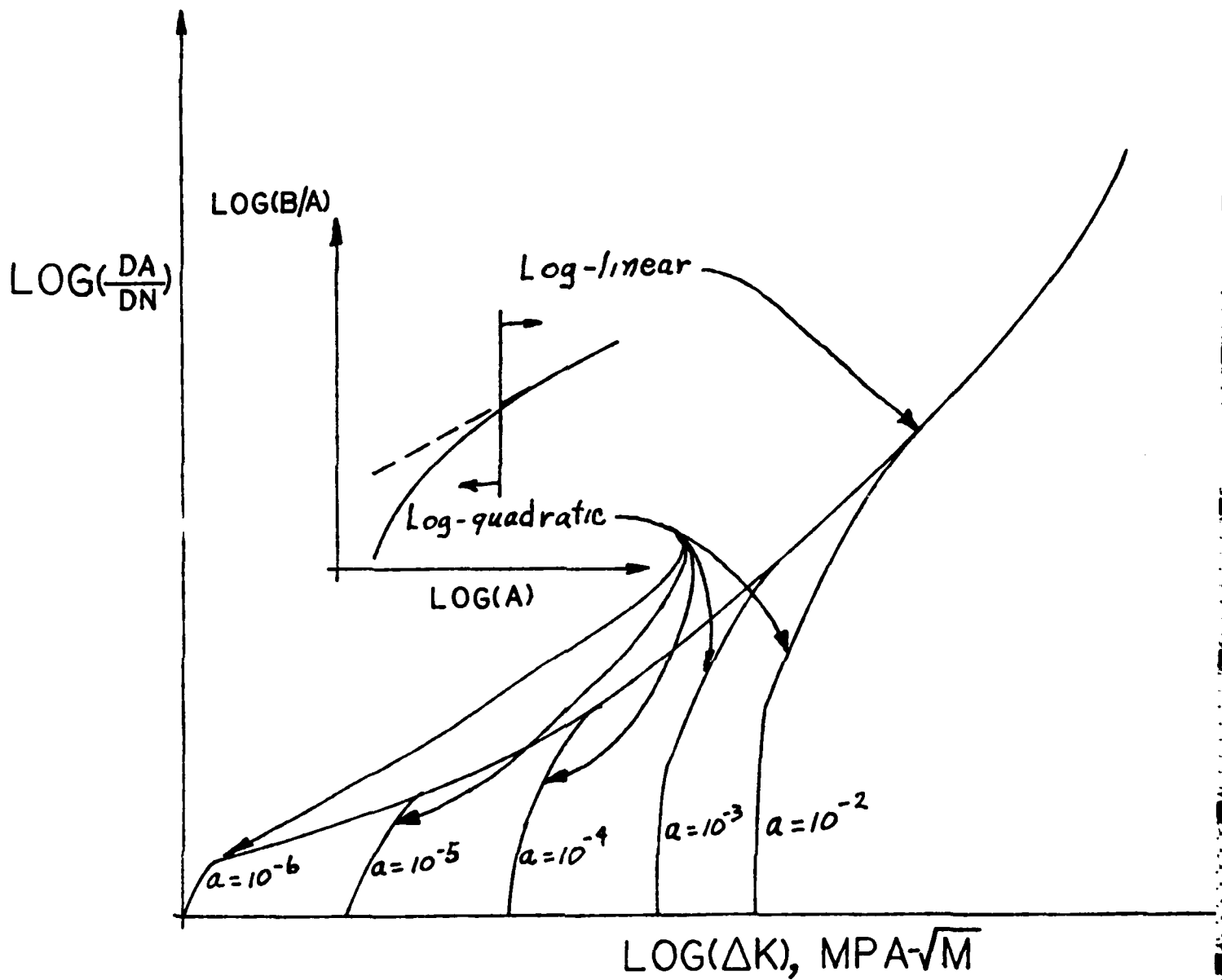

Fig. 10. Initiation of Growth of Small Cracks.

For the case of cyclic loading equation (16) can be easily integrated to yield crack length versus cycles of loading. However, it is necessary to consider the change of crack sharpness with time during cyclic loading. The crack starts out blunt according to equation (17) and sharpens to the critical value expressed as equation (16) at failure. Since the entropy function is a measure of irreversibility (damage), the critical sharpness is postulated to occur when the local entropy gain at the crack tip reaches the critical entropy threshold:

$$\frac{b}{a} = \frac{b}{a}_c [1 - (\sigma_c/\sigma)^{0.5}] \frac{S}{S_f} + [\sigma_c/\sigma]^{0.5} \quad (18)$$

For different order of loading, equation (18) could be applied piecewise to generate crack sharpness as a function of time.

The memory of plastic deformation history expressed in equation (18) provides a valuable tool for investigation of variable loading and spectrum loading. Figure 11 is a plot of crack length versus cycles of loading for two sets of three identical average loading histories with different levels in different order. Figure 11 clearly shows that the order of loading is very important to accurately predicting the useful life of the structure. Figure 11 is significant since crack growth dependence on loading history is demonstrated on a theoretical basis. Figure 11 is an approximation, however, since the plastic deformation history of the material ahead of the crack will effect the crack growth rate. For brittle materials where such plastic deformation history is a small effect, this approximation would be expected to be quite good. However, for more ductile materials, plastic deformation

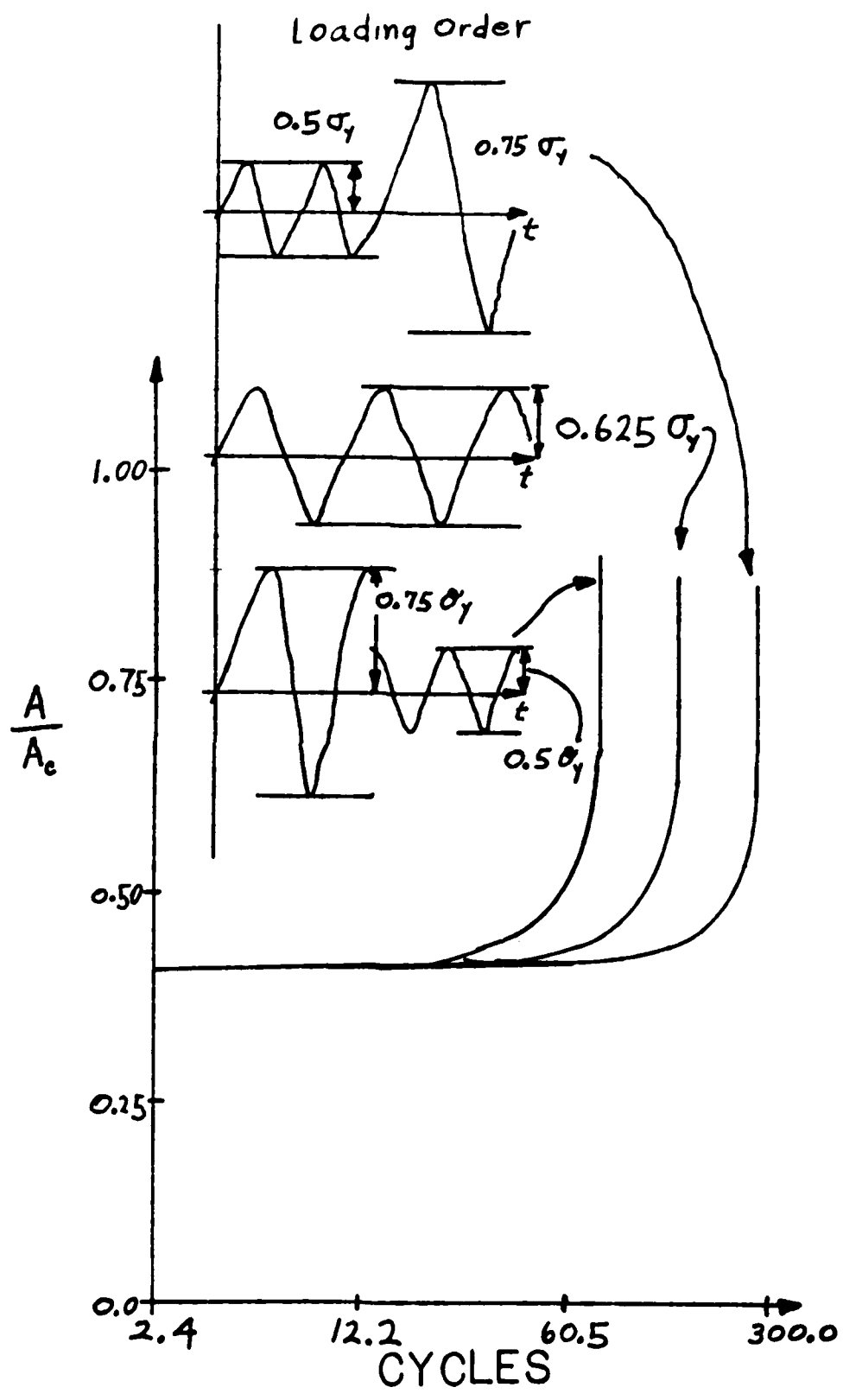

Fig. 11. Effect of Loading Variation on Crack Growth.

history of each point ahead of the crack would significantly influence the crack growth.

Crack Growth With Mean Stress

Figure 12 shows the effect of mean stress on crack growth. For higher mean stress, the overall level of yielding is higher and the slope of the crack growth rate curve decreases. In the case that the static load is much greater than the cyclic load, the static fracture toughness would dominate. The general trends summarized in Figure 12 are in substantial agreement with the results given in References [61] and [62] with increasing mean stress increasing the crack growth rate.

The influence of mean stress is commonly described in terms of the R-ratio in fracture mechanics terminology. Figure 12 was prepared consistent with that terminology using the combination of static and dynamic strain levels demonstrated in the inset to Figure 12. However, since a local relationship was used, the hysteresis loop was defined using Figure 6 where the cyclic strain amplitude was different from the maximum strain. Using the inset of Figure 12, $\epsilon_o = \epsilon_c + \epsilon_s$, and resulting R-ratio is defined to be:

$$R = \frac{\epsilon_c - \epsilon_s}{\epsilon_c + \epsilon_s}$$

Reference [63] describes dependence of crack growth on R-ratio for low stress intensity factor. Figure 12 provides a theoretical basis for the experimental results given in Reference [63].

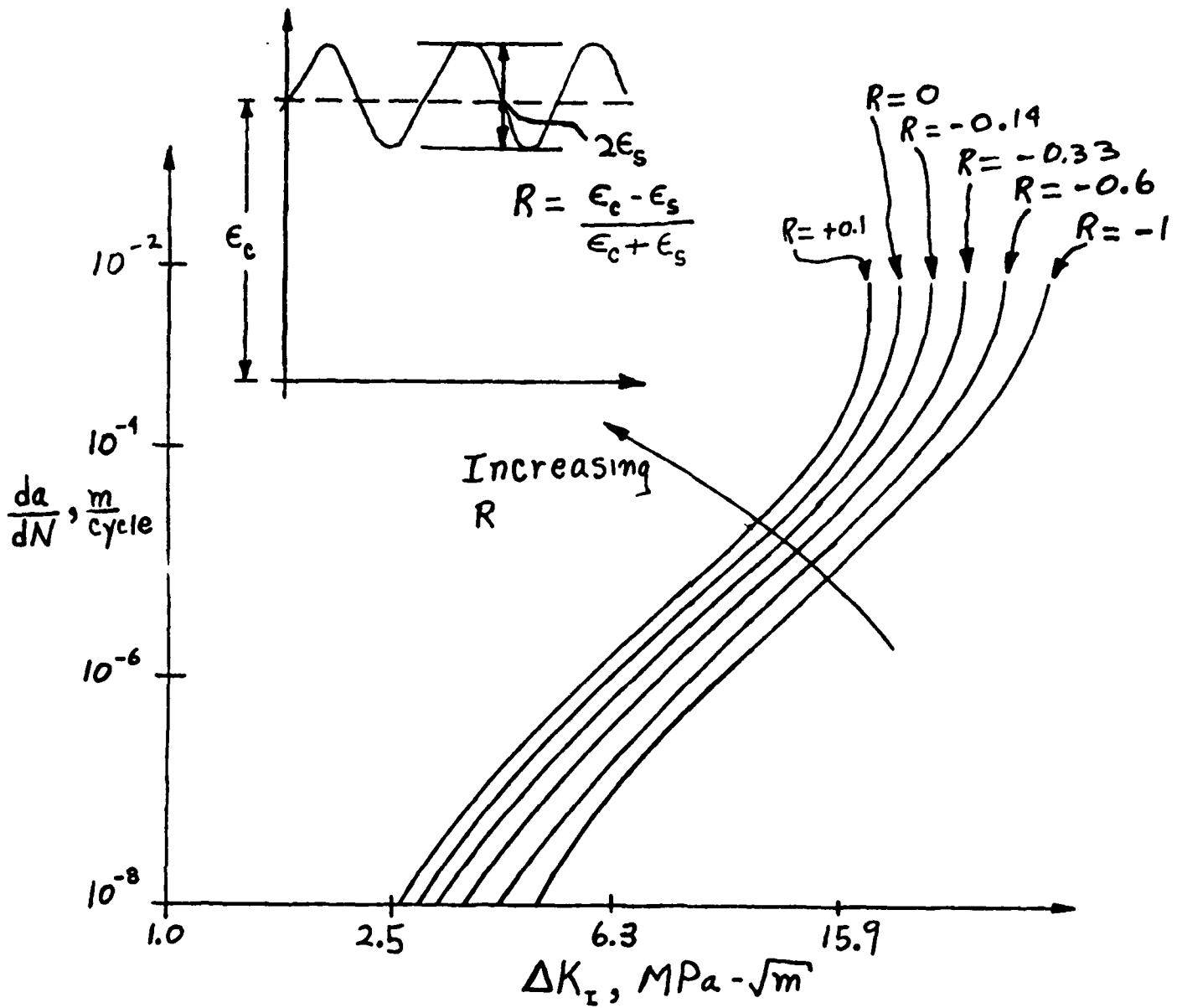

Fig. 12. Crack Growth Rate Dependence on Mean Stress.

DISCUSSION OF DAMAGE IN METALS

A local theory of fatigue and fracture for isotropic, homogeneous engineering materials has been described. Static fracture, crack growth under cyclic combined loading, and loading history have all been expressed on a theoretical foundation of irreversible thermodynamics. This approach could be quite useful in the analysis of crack retardation and closure, as well as spectrum loading. The theory is consistent with well-known principles of linear elastic fracture mechanics. The model predicts very high strain levels near the tip of a yielding crack but finite stresses at the crack tip, even for the infinitely sharp Griffith crack. Local necessary and sufficient conditions for unstable crack growth have been expressed in a local energy balance form analogous to the well known Griffith criterion, given by equations (4) and (5).

This treatment of local crack-tip plasticity has the potential for explaining diverse phenomena. Once yielding has occurred the probability distribution function will change and subsequent loadings will result in a modified stress-strain relationship. Additional analysis is needed to investigate the influence of plastic deformation history on fatigue life under spectrum loading; the influence of different frequency of loading is still unknown. Using the displacement field near the crack tip, plastic strain history can be used to investigate the phenomena of crack closure and retardation.

It is postulated that as a crack grows it is blunted. This is consistent with the well known observation that crack blunting retards crack growth making predictions based on elastic theory conservative. Therefore the crack sharpness,

b/a , is a very important variable during crack growth, and a critical crack tip bluntness function has been determined. The familiar sigmoidal shape of the da/dN versus ΔK_I curve has been reproduced, giving results consistent with the well-known Paris Law. The appearance of the stress-intensity threshold can be demonstrated on a theoretical basis, as well as the infinite slope of the da/dN curve at the fracture toughness. Since the local random yielding model is not limited by small scale yielding assumptions, it can be applied to any engineering material. Since the use of composite materials has become so widespread, there is considerable motivation for analysis of fatigue and fracture of composites. In the next section, preliminary analysis of fatigue and fracture of composite materials is described.

APPLICATIONS TO COMPOSITE MATERIALS

The engineering analysis of composite structures is inherently more complex than for metals. While metals are typically considered to be homogeneous, isotropic media, composite materials are anisotropic and nonhomogeneous. In addition, the mathematical definitions of differential stress, strain, displacement, mass, and even volume has to be modified depending on the type of composite structure under analysis[64]. There are different ways to embed fibers in a matrix, and each approach results in different assumptions. In general, the geometry of composite structures is quite complex, and as a result the different ways composites can fail becomes very complicated.

As damage occurs in any material, metal or composite, the strength and stiffness characteristics are known to change. The change in stiffness is a convenient definition of fatigue damage since stiffness changes can be defined analytically and can be measured by changes in the natural frequency. In contrast with isotropic materials like metals, the anisotropy of fiber reinforced composite materials introduces at least three distinct failure modes for each lamina. When the strength of the fibers is exceeded, the fibers would fail in tension; cracks could also form within the laminate due to stresses transverse to the fibers; finally, the bonding of the resin between lamina could fail giving delamination[65]. Although in isotropic materials failure can be characterized by (1) crack nucleation or crack initiation, and (2) crack propagation, the formation and growth of cracks in composite materials is very complicated and does not necessarily

constitute failure. In fact, many composites begin to form fatigue cracks within the first few cycles of loading[65]. The different modes of failure during tension fatigue tests can be related to the stress amplitude; for high stresses there is a high percentage of fiber failures[66]. For intermediate stresses, the fiber breakage plays a less dominant role, and matrix cracking leading to delamination is the common mode of failure. For low stress levels, very few fibers fail, and some cracks form in the matrix.

Highsmith and Reifsnider[67] have described the relationship between reduced stiffness during fatigue and the crack density using a finite difference solution of the six stress components throughout a laminate. A digital computer solution was required and only a few layers could be included due to computer storage limitations. Tensor stiffness changes were related to matrix cracking in an attempt to define working engineering definitions of laminate damage. Stiffness reduction can be a useful preliminary definition of damage in composite materials, although there are numerous possible definitions for damage[68].

The fundamental engineering definition of fatigue damage in composite structures is similar to that in metals: strength degradation resulting from repeated loadings. Changes in the hysteresis loop and static stress-strain curves during fatigue damage are very similar to the effects observable in metals[69]. Stiffness reduction during fatigue results in deflections under load which constitute failure in some applications, while crack growth is used to quantify failure in other cases. Delamination is one of the failure modes which

depends on formation and growth of cracks, although the fracture mechanics for that problem is considerably more complex[70].

Although modulus shift can sometimes be used effectively as a measure of damage, the definition of damage must relate to changes in the structure of the material. Fong[68] lists five discrete processes of fatigue research suggested by the American Society for Testing and Materials leading to the ultimate goal of predicting fatigue life from measurements of damage: 1. Measurement, 2. Data Analysis, 3. Nonlinear Modeling 4. Evolutionary and Thermodynamic Theory, 5. Codes and Standards Development. The fourth process, thermodynamic theory, is analyzed in this report.

The irreversible thermodynamic analysis of fiber reinforced laminated beams is described, including the anisotropic nature of composite materials. An Orthotropic damping model is developed based on the fractional calculus approach in the low amplitude portion of the analysis[71], and local random yielding after the approach by Whiteman[46] is used in the high amplitude portion of the response. The influence of shear deformation and rotary inertia in thick beams is investigated, and fatigue damage is considered to occur in composites as a result of irreversible deformation providing a decrease in the laminate transverse stiffness, measurable by a decrease in natural frequency. Although this analysis was conducted under the definition of modulus shift for fatigue damage, the local random yielding in an orthotropic lamina is used as a mathematical description of local strength degradation. In contrast with homogeneous, isotropic

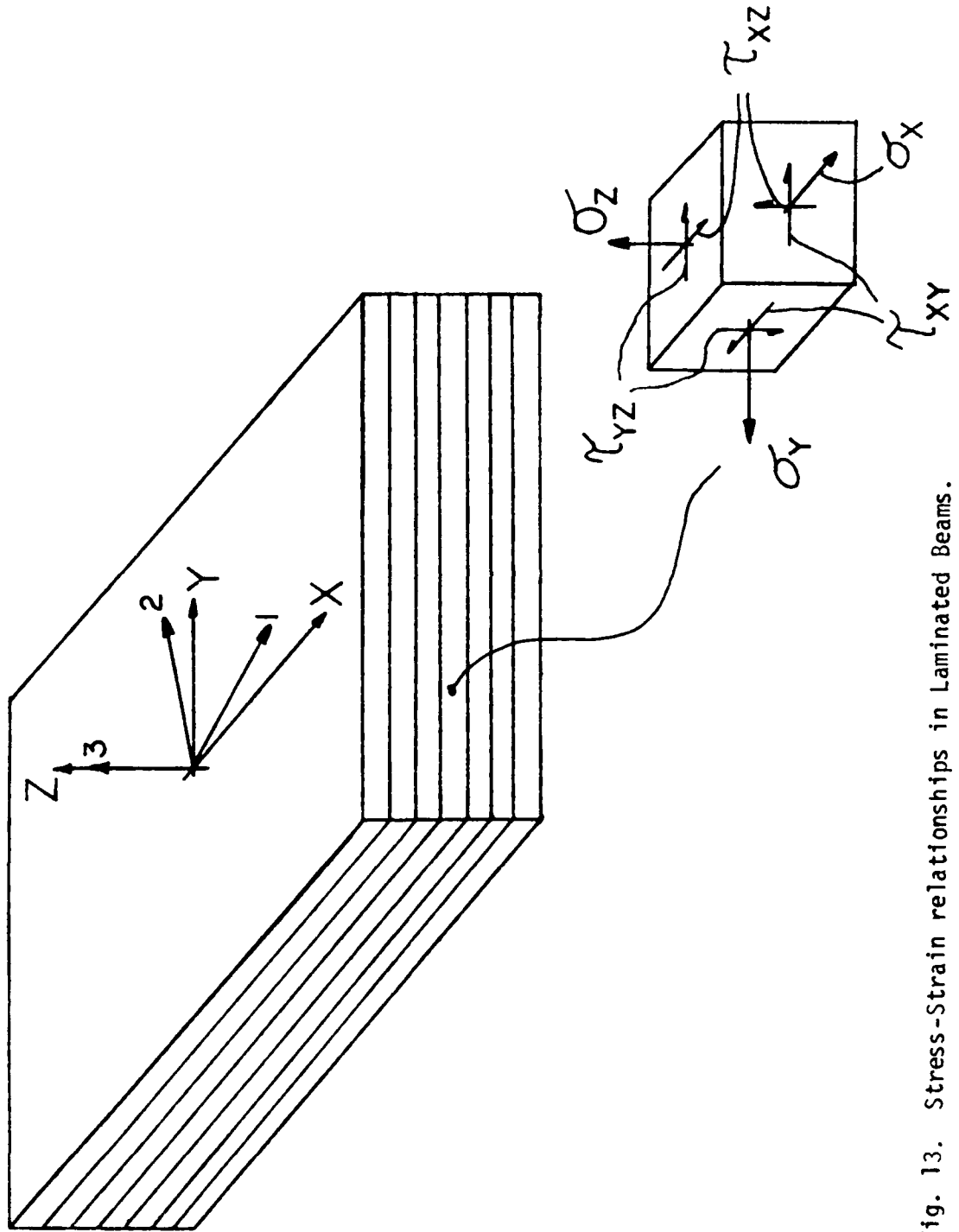

Fig. 13. Stress-Strain relationships in Laminated Beams.

A laminate damping model based on viscoelasticity and random yielding is developed below which provides a theoretical basis for the irreversible thermodynamics of composite beams. Referring to Figure 6, the laminated beam dynamic moment equation is modified using the complex modulus formulation and an orthotropic damping model based on random yielding. Frequency and strain amplitude dependent loss factor in the fiber direction and perpendicular to the fiber direction are defined by:

$$\eta_1(\epsilon, \omega) = [1 - E_{S1}^2 + \eta_{01}]^{0.5} \quad (21a)$$

$$\eta_2(\epsilon, \omega) = [1 - E_{S2}^2 + \eta_{02}]^{0.5} \quad (21b)$$

In equations (21), E_{S1} and E_{S2} are normalized storage moduli resulting from random plastic strain in the 1 and 2 directions, respectively and P is the probability distribution function for plastic strain as in equation (9). The probability distribution function of the random plastic strain is assumed to follow the log-normal relationship, and equations (21) are to be combined with equation (19) and (20) yielding complex moduli for the laminate according to:

$$Q_{11}^* = Q_{11}(\cos\eta_1 + j\sin\eta_1) \quad (22a)$$

$$Q_{12}^* = Q_{12}(\cos\eta_2 + j\sin\eta_2) \quad (22b)$$

$$Q_{21}^* = Q_{21}(\cos\eta_1 + j\sin\eta_1) \quad (22c)$$

$$Q_{22}^* = Q_{22}(\cos\eta_2 + j\sin\eta_2) \quad (22d)$$

$$Q_{66}^* = Q_{66}(\cos\eta_2 + j\sin\eta_2) \quad (22e)$$

Then the energy dissipated in each lamina comes from three stresses which result from the single strain in a laminated beam in bending with negligible transverse shear deformation:

σ_x , σ_y , and τ_{xy} . Although there will be two loss factors in the beam axis system, transverse strains are negligible for thin beams and energy dissipated within the beam will be dominated by the bending deformation[73]. For each point in the beam the ratio of the energy dissipated per cycle to the energy stored per cycle for strain in the x and y directions are:

$$\eta_x = I_m [D_{11}^*] / |D_{11}^*| \quad (23a)$$

$$\eta_y = I_m [D_{21}^* + D_{31}^*] / |D_{21}^* + D_{31}^*| \quad (23b)$$

Figure 14 is a plot of loss factor, η_x , versus strain level for unidirectional longitudinal and transverse orientation and cross-ply beams, along with data from Gibson[74]. Qualitative agreement with previous results is demonstrated[75]' [76]. This orthotropic damping model has the advantage that the effect of fiber orientation is inherently included, as are frequency, strain-amplitude, and temperature dependence of loss factor. The general theory of irreversible energy dissipation in a laminated beam is described in the next section, in preparation for derivation of a mathematical model for fatigue.

Energy Dissipation And Fatigue In Thin Laminated Beams

The orthotropic damping model for fiber reinforced composite materials forms the basis for analysis of reversible and irreversible energy transfer. Fatigue damage is assumed to result from irreversible energy transfer resulting from plastic deformation within the laminated beam. There are three different mechanisms of damage in thin beams which are to be

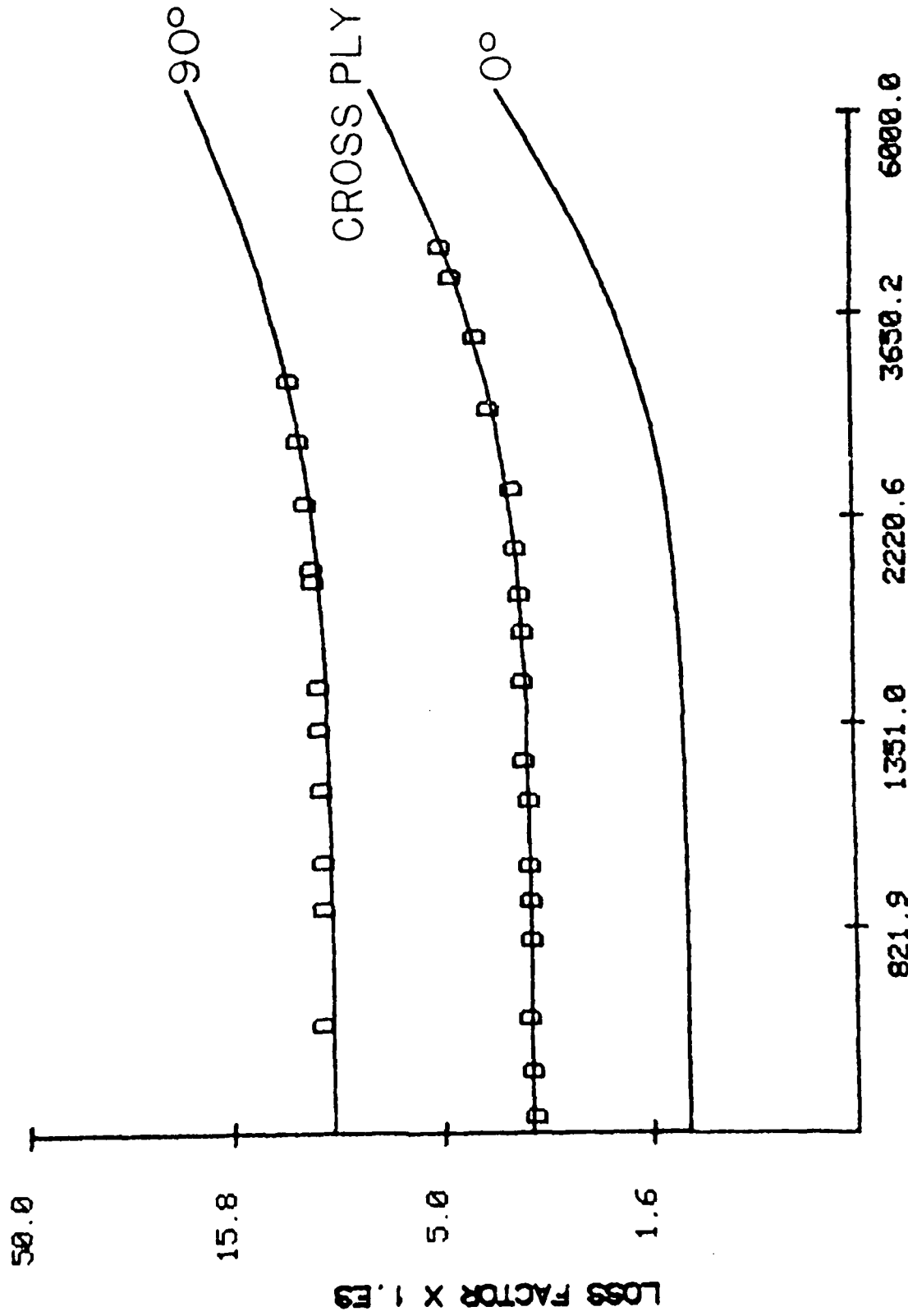

STRAIN AMPLITUDE $\times 10^6$

Fig. 14. Laminate Damping Model Based on Local Random Yielding Along with Data from Gibson[72]

modeled here. First, loads in the fiber direction could damage the fibers. Second, loads perpendicular to the fiber direction could damage the matrix. Finally, shear loads within layers could cause damage from in-plane shear. Delamination failure cannot be explained using thin beam theory since interlaminar stresses are ignored. These three common forms of failure in composites are modeled mathematically by the local isothermal entropy thresholds of failure defined below (see equation 6):

$$\begin{aligned}
 S_{f1} &= \int_0^{\epsilon_f} \sigma_{11} \epsilon_{11} P(\epsilon_{11}) d\epsilon_{11} \\
 &= Q_{11} \int_0^{\epsilon_f} \left\{ \epsilon_{11}^2 \left[1 - \int_0^{\epsilon_{11}} P(n) dn \right] + \epsilon_{11} \int_0^{\epsilon_{11}} n P(n) dn \right\} P(\epsilon_{11}) d\epsilon_{11} \quad (24a)
 \end{aligned}$$

$$\begin{aligned}
 S_{f2} &= \int_0^{\epsilon_f} \sigma_{22} \epsilon_{22} P(\epsilon_{22}) d\epsilon_{22} \\
 &= Q_{21} \int_0^{\epsilon_f} \left\{ \epsilon_{22}^2 \left[1 - \int_0^{\epsilon_{22}} P(n) dn \right] + \epsilon_{22} \int_0^{\epsilon_{22}} n P(n) dn \right\} P(\epsilon_{22}) d\epsilon_{22} \quad (24b)
 \end{aligned}$$

$$\begin{aligned}
 S_{f3} &= \int_0^{\gamma_f} \tau_{12} \gamma_{12} P(\gamma_{12}) d\gamma_{12} \\
 &= Q_{66} \int_0^{\gamma_f} \left\{ \gamma_{12}^2 \left[1 - \int_0^{\gamma_{12}} P(n) dn \right] + \gamma_{12} \int_0^{\gamma_{12}} n P(n) dn \right\} P(\gamma_{12}) d\gamma_{12} \quad (24c)
 \end{aligned}$$

Equations (24) represent the result of tensile and shear tests on a single layer yielding a mathematical model for fatigue damage in laminates. For fatigue damage due to cyclic loading, the irreversible part of the energy dissipated per cycle is measured by the entropy gain per cycle. Fatigue damage is modeled by the entropy rate, calculated from the plastic part

of the loss factor. For a particular laminated beam, the entropy rates from random plastic straining under sinusoidal excitation in each layer are:

$$dS_1/dt|_k = \pi \text{Im}[Q_{11}^*] \epsilon_1^2 (\epsilon_{p1}/\epsilon) \quad (25a)$$

$$dS_2/dt|_k = \pi \text{Im}[Q_{21}^*] \epsilon_2^2 (\epsilon_{p2}/\epsilon) \quad (25b)$$

$$dS_3/dt|_k = \pi \text{Im}[Q_{31}^*] \gamma_{12}^2 (\epsilon_{p3}/\epsilon) \quad (25c)$$

Equations (24) and (25) represent an energy-based analysis of damage, and can readily be extended to the case of crack growth in composites as has already been demonstrated for metals. Steif[77] has investigated stiffness reduction due to fiber breakage, which also contributes to transverse-ply matrix cracking. His approach was energy-based as well, considering the strain energy density change when a fiber breaks. In this way, the necessary analysis of the state of internal damage is reflected in the external measure of stiffness reduction. Such a measurement has potential applications in fracture mechanics where compliance is related to fracture mechanics parameters. Equations (24) and (25) can be combined to predict the number of cycles to specified stiffness reduction by combined fiber breakage, matrix cracking, and in-plane shear. The layer corresponding to maximum entropy rate will be loading history dependent, progressing through the laminate as each layer fails. This concept of damage is therefore a realistic one, because damage in a single layer does not necessarily represent overall failure. Rather, damage in a single layer represents a weakening of the structure which could then be used to define a new maximum entropy rate providing a methodology for predicting not only the lifetime but also the

mode and location of failure. Multiple failure modes are therefore explicitly included in this model.

The modulus shift in a beam is calculated by omitting the particular failed stiffness component from the laminate stiffness calculation. That is, when the maximum entropy gain in the fiber direction defined by equations (25a) exceeds the critical fiber entropy threshold in the k th layer as defined by equations (24a), then E_1 is set to zero. When the maximum entropy gain perpendicular to the fiber direction defined by equation (25b) exceeds the matrix critical entropy threshold of the k th layer as defined by equation (24b), then E_2 is set to zero. Finally, when the maximum entropy rate for shear between lamina defined by equation (25c) exceeds the in-plane shear critical entropy threshold of the k th layer defined by equation (24c), then G_{66} is set to zero. Each time a lamina failure is defined, a new beam moment equation can be calculated, omitting the failed lamina stiffness from that layer and defining a new beam stiffness. In this way, the reduction in stiffness can be used to quantify fatigue damage; a conservative estimate of damage is assumed since residual stiffness would certainly occur and is not included in this analysis.

This definition of damage is convenient since the measurement of damage is based on external measurements of stiffness reduction while the damage mechanism reflects changes in the internal structure of the material. Schapery[78] described linear viscoelastic constitutive equations with damage in terms of hereditary integrals which are strikingly similar to the entropy threshold definition of damage used here. Damage was described in terms of strain and stress

tensors for finite strain using the Gibbs free energy function for elastic materials. The entropy gain was one of the terms in the Gibbs free energy function. The critical entropy threshold of local failure defined here is attractive both because of the intuitively pleasing physical interpretation and the apparent universal applicability. Note that the approach described here is loading history dependent, since when the k^{th} lamina fails in a particular mode, the remaining stiffness elements experience higher loads resulting in increased damage accumulation and subsequent failure.

Figure 15 is a plot of lifetime to 30 percent stiffness reduction for a laminated unidirectional beam for 0 and 90 degree orientation of the fibers, and for a cross-ply laminate. Figure 15 was generated by successively calculating the maximum entropy rate, and then deleting the corresponding stiffness element of that lamina from the analysis, keeping track of mode and location of each failure until the modulus shifted as specified. Additional laboratory data are required to conclude the accuracy of the predictions of failure modes, but the results summarized in Figure 15 are in substantial agreement with previous results [79]. For the unidirectional beam, the primary failure mode is fiber breakage for longitudinal fibers and matrix cracking for transverse fibers. The failure starts at the outside surface of the beam where the strain amplitude is a maximum and progresses toward the center of the beam. For the cross-ply beam, the primary failure mode was matrix cracking in the transverse layers starting near the beam surface and working inward. There was also a secondary failure mode of fiber breakage in the longitudinal layers caused by the

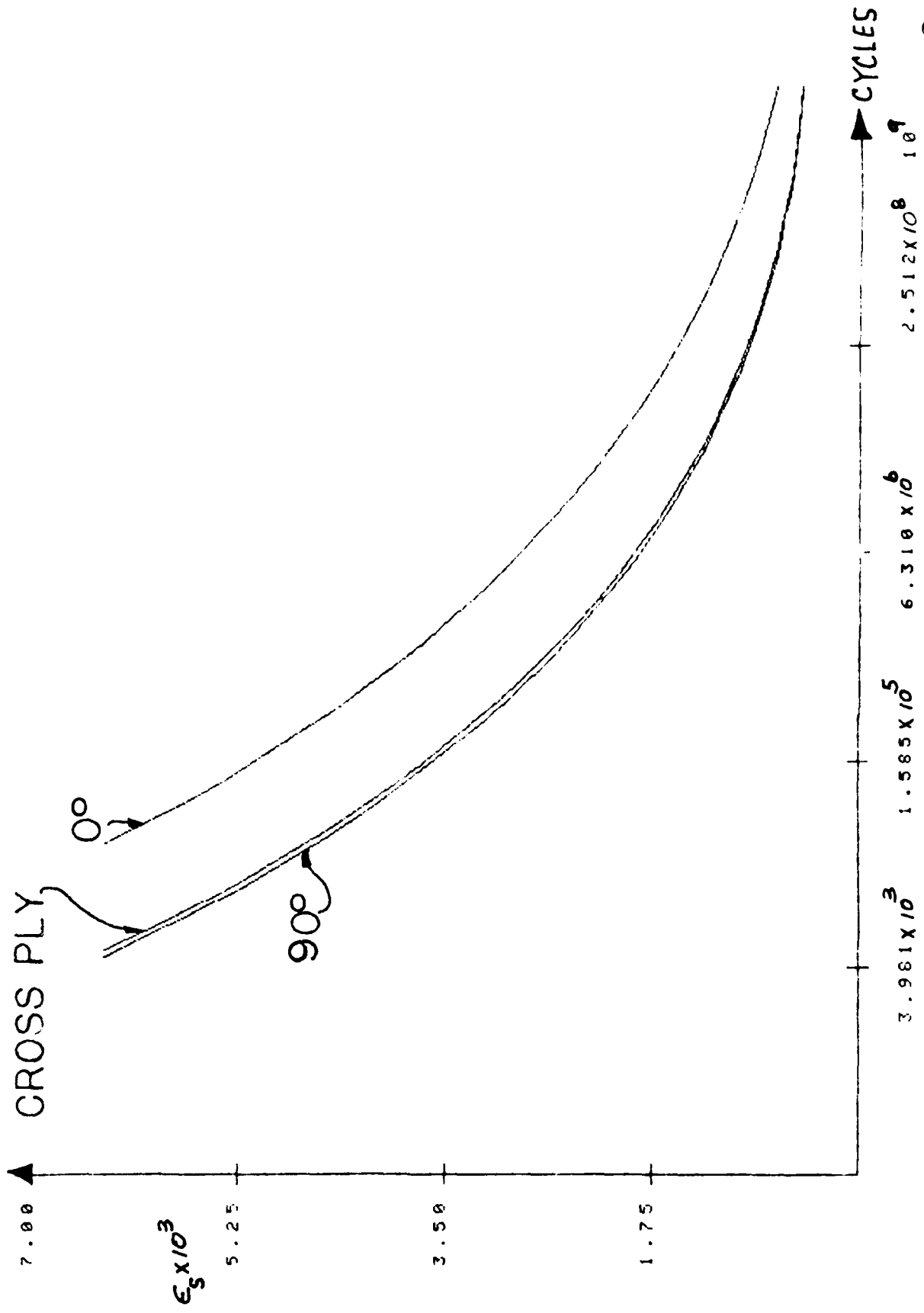

Fig. 15. Fatigue Lifetime to 30 percent Stiffness Reduction for Unidirectional and Cross-ply Laminated Beams

in-plane transverse stress and shear stress. This is as expected for the simple cantilever unidirectional and cross-ply beams since the location of maximum strain is known. None of these calculations indicated primary failure from in-plane shear deformation.

This analysis of damage shows realistic predictions for fatigue lifetime in thin beams. A practical application must include structures with many layers, involving thicker beams where shear deformation could be significant. These shear stresses could cause delamination, which is the subject of the next section.

Failure Modes In Thick Beams

When the thickness is not small compared to the length of a beam, then out-of-plane shear stresses may not be negligible. The influence of shear deformation must therefore be investigated along with the various possible failure modes. These interlaminar stresses are believed to be responsible for delamination failures in fiber reinforced composite materials [72]. Such thick structures are practical when numerous layers exist in a composite structure. When a beam is thick compared to the length, then shear deformation and rotary inertia may have a significant effect. Although the transverse normal stress, σ_y , is assumed to be small compared to the bending and shear stresses, the normal strain may not be small and in fact may significantly affect delamination[80]. Moments in the beam are influenced by the shear deformation. Curvature along the y-axis is assumed to be negligible so that bending stresses arise only from $\partial^2 y / \partial x^2$. Likewise, the interlaminar shear

strain γ_{xz} arises from shear forces in the beam as demonstrated in Figure 13. Equations (19)-(25) must be supplemented by an additional entropy rate term resulting from the out-of-plane shear strain, γ_{xz} and the normal strain ϵ_z . The influence of transverse strain and shear loads are included in the entropy rate terms given below.

$$S_4 = \pi \text{Im}[\bar{Q}_{31}|_k] \epsilon_3^2 (\Delta \epsilon_{p4}/\epsilon_3)$$

$$S_5 = \pi \text{Im}[\bar{Q}_{45}|_k] \gamma_{23}^2 (\Delta \epsilon_{p5}/\gamma_{23})$$

$$S_6 = \pi \text{Im}[\bar{Q}_{55}|_k] \gamma_{13}^2 (\Delta \epsilon_{p6}/\gamma_{13})$$

The loss factor for the shear strain γ_{xz} is assumed to be equal to n_2 , since resin properties dominate for shear deformation. Figure 16 is a plot of lifetime to 30 percent stiffness reduction in thick crossply beams.

For $h/l = 0$, the thin beam results for a cross-ply laminate given in Figure 15 are reproduced with the dominant failure mode being matrix cracking. Secondary failure modes are fiber breakage in longitudinal layers and delamination in transverse layers. For $h/l = 0.20$, the influence of shear deformation is apparent, and the time to 30 percent stiffness reduction is reduced somewhat. For $h/l = 0.60$ the primary failure mode is delamination from transverse shear, with fiber breakage and matrix cracking as secondary mechanisms. Although Pagano and Pipes[81] hypothesized that delamination is caused by transverse normal stresses, this analysis suggests that the transverse shear strains are the dominant damaging loads; fatigue damage can still progress in the remaining load carrying elements and secondary failures can occur in the same layer.

Although laboratory data is required to substantiate the

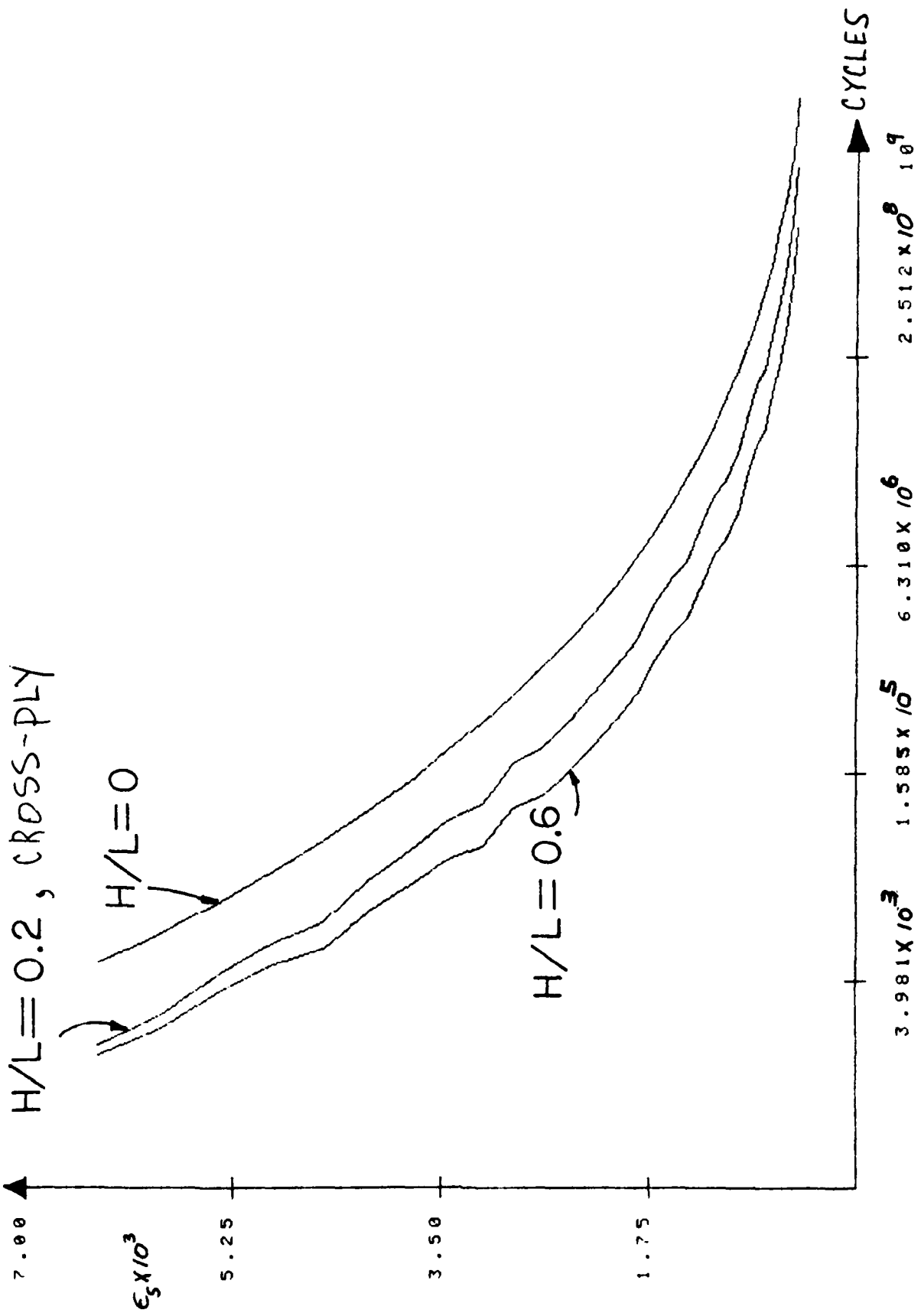

Fig. 16. Fatigue Lifetime to 30 percent Stiffness Reduction for Thick, Cross-ply Laminated Beams

detailed predictions of multiple combined failure modes, the significance of these results is that complicated multiple failure mechanisms are simplified to stiffness reduction. This is a practical definition of damage, indicating when a composite structure is no longer able to function as designed. In fact, it may not be desirable to substantiate each failure during fatigue testing. For fiber reinforced composite materials such data collection and processing would be excessively expensive. Rather, relatively simple lifetime to fixed modulus shift tests could substantiate the irreversible thermodynamics theory for certain standard orientations. A fully validated theory could be of considerable value to the designer who is interested in choosing orientations and thicknesses to satisfy some particular design requirement.

This analysis has been based on the simplified assumption that the critical entropy threshold is a definition for failure. Irreversible thermodynamics should be included in a comprehensive fracture mechanics analysis of composite materials.

Analysis Of Fracture In Composites

Linear elastic fracture mechanics can be very effective in tracking crack growth in brittle materials. For ductile materials, linear elastic fracture mechanics can still be applied whenever the crack length is large compared to the zone size of significant plastic deformation. When there is considerable yielding due to plastic deformation, linear elastic fracture mechanics does not apply. It has been demonstrated that the local random yielding model of plasticity

predicts crack growth and fracture relationships consistent with linear elastic fracture mechanics without theoretical limitations as to amount of yielding. However, these theories were developed for homogeneous, isotropic materials; composite materials are inherently nonhomogeneous and anisotropic.

For composites, the analysis of crack growth, fracture, and fatigue damage must address the nonhomogeneous, anisotropic property, as well as fiber orientation, ply geometry, resin volume percent, etc. In the case of metals, the specimen geometry must be selected to cover the loading ranges of interest involving substantial testing. For composite materials the many different possible combinations of important parameters would require impractical test programs. That is why accurate mathematical models for fatigue and fracture in composites would be a significant advance.

Wu[82] has investigated the linear elastic fracture mechanics of unidirectional glass reinforced epoxy resin with a crack parallel to the fiber direction. He concluded that the critical stress intensity factor does not vary significantly with crack length. Gagar and Broutman[83] have investigated the fracture mechanics of random glass fiber epoxy composites. They concluded that the stress-intensity factor from linear elastic fracture mechanics is suitable to characterize the fracture of random fiber composites. This is logical since random short fiber composites can frequently be approximated as homogenous, isotropic materials.

Since linear elastic fracture mechanics applies best to materials which do not yield substantially, linear theory should accurately describe fracture of composites. However,

the specimen thickness directly influences the crack-tip state of stress which in turn influences the yielding. Before linear elastic fracture mechanics can be routinely applied to composite materials, it is necessary to identify limitations of thickness and load. Harris and Morris[84] have investigated the fracture of thick, laminated graphite/epoxy composites. They conducted a predominantly experimental research program of various cross-ply and angle-ply laminates of various thicknesses, using center-cracked tension, compact tension, and three point bend specimen configurations. Fracture toughness was calculated using a finite element stress analysis, and damage development at a crack tip was investigated using enhanced X-ray radiography and the laminate deply technique. For $[0/\pm 45/90]_{ns}$ and $[0/90]_{ns}$ laminates, the fracture toughness decreased with increasing thickness, while for $[0/\pm 45]_{ns}$ laminates the fracture toughness increased with increasing thickness. Fracture toughness of laminated Graphite/Epoxy composites is dependent on thickness.

The principles of linear elastic fracture mechanics have been successfully applied to composite materials in predicting crack initiation and propagation and fracture. It should also be possible to formulate crack growth and fracture of composites based on the local random yielding model, which has been demonstrated to be consistent with the fundamental principles of fracture mechanics. However, in a general laminated plate or beam the combined state of stress within the laminate is required, and mixed mode fracture would be expected. Mixed mode fracture could be analyzed as in Reference [85].

RECOMMENDATIONS AND CONCLUSIONS

A local criterion for crack extension has been presented, providing comprehensive results consistent with linear elastic fracture mechanics. Using the original stress analysis by Inglis[20], the displacement field around an elliptical hole in an infinite thin sheet was differentiated, leading to a nonlinear strain function. This strain function is singular at the crack tip, consistent with the principles of linear elastic fracture mechanics. However, the local random yielding model for the microstructure at the crack tip results in a finite local stress. The magnitude of this local random stress depends on the sharpness of the crack; stress is high for sharp cracks, lower for blunt cracks. This crack sharpness function was found to be log-linear in the critical crack length, and a relationship between the critical stress and critical crack length can be defined.

In the case of cyclic loading, local random yielding was used to derive a mathematical model for internal friction providing a basis for irreversible thermodynamic analysis of crack growth. A local necessary and sufficient condition for crack extension was derived from the strain energy density function near the crack tip. It has been demonstrated that the local plastic strain energy density at the crack tip is a constant at failure. In the case of isothermal processes, the irreversible entropy gain at fracture is therefore a constant, lending credibility to the hypothesis that the local critical entropy threshold of fracture is a material constant. In the case of cyclic loading, the local entropy rate is combined with the strain energy release rate to give a theoretical crack

growth curve consistent with the familiar Paris law. In addition, the existence of a threshold stress intensity factor is demonstrated, and growth of small cracks is defined.

For very small cracks, the time to reach the critical entropy threshold is dependant on the crack sharpness, and as crack length approaches zero the theoretical basis for crack nucleation has been described. The local random yielding model is not limited by assumptions of small-scale yielding, so virtually any engineering material and any crack size can be analyzed. The fact that the local random yielding model reproduces a myriad of well-known results from linear elastic fracture mechanics provides convincing support for the validity of the critical entropy threshold of local fracture.

In addition to the satisfying intuitive nature of the critical entropy threshold of fracture due to irreversible plastic deformation, a number of related theories are unified by this local analysis of crack growth. First, local random yielding is a mathematical model for plastic flow with a strong theoretical basis in dislocation theory. It is commonly accepted that plastic deformation arises due to dislocation motion, and the local random yielding model supplies the relationship between dislocation theory and plasticity theory. It has been demonstrated that local random yielding is consistent with fracture mechanics. Irreversible thermodynamics has been applied to the local random yielding model, so a unified theory of local fracture including irreversible thermodynamics, plasticity theory, fracture mechanics, and dislocation theory is offered for scrutiny by the scientific community.

Having reproduced results which are already widely available is only of academic interest. However, the problems of crack retardation, closure, loading history, and spectrum loading continue to be subjects of research effort. Since the entropy gain is history dependent, the dependence on loading history is readily available from the local random yielding model. As crack growth is initiated, the material ahead of the crack experiences varying plastic deformation history giving a loading history dependent crack growth curve.

The process of crack retardation due to transient overloads is an observed phenomenon without a rigorous theoretical basis as yet. The local random yielding model of plastic deformation is offered as such a theoretical basis for retardation. The accumulation of variable entropy gain due to plastic deformation ahead of the crack tip is likely to be an important mechanism during crack retardation since transient overloads increase the residual compressive stress within the plastic zone. Also, transient overloads drive the crack tip into plastically deformed material increasing the bluntness and subsequently decreasing the local stress level at the crack tip. Although time and budget constraints have precluded this analysis in the present research, local random yielding is useful for such an analysis of retardation.

Finally, resonance, spectrum loading, and combined loading can be readily evaluated using the local random yielding model through appropriate definition of the entropy rate. The local random yielding model is capable of providing such analysis. Before initiating such a comprehensive research program, it would be necessary to develop suitable laboratory experiments

so that data development could proceed concurrent with the theoretical analysis.

Since the local random yielding model for fracture is not constrained to any particular material, efforts should be initiated to evaluate its suitability for a variety of engineering materials. Only three parameters are required which would be selected on the basis of experimental data. The variance of the log-normal local random yielding can be selected either from internal friction data at high strain amplitudes or tangent modulus. The critical crack sharpness function is based on standard fracture toughness static tests. Finally, the frequency dependence of the internal friction would be determined from loss factor at low strain amplitudes. Additional work would be needed to verify that these three constants are sufficient to define any particular engineering material.

One extremely appealing aspect of the local random yielding model is its universal application. Virtually any engineering problem involving large-scale yielding where a displacement gradient can be defined is a candidate for the local random yielding model. One such candidate is the problem of moving asperities traversing at high speeds over the surface of a marine seal ring. Reference[86] describes such an application, where heat checking from cyclic asperity excitation might indicate a thermodynamic analysis, and where crack growth would initiate below the surface. Although not specifically addressed in this research, the temperature dependence of the local random yielding model can also be evaluated. It is possible that the local random

yielding approach could result in simplified mathematics since a displacement gradient is sufficient to provide the stress-strain field, with no limitations concerning plastic deformation. Therefore, the local random yielding approach would not be limited to brittle failure. The preliminary analysis of laminated beams indicates that the local random yielding can be successfully applied to anisotropic materials as well.

REFERENCES

1. Miner, M. A., Transactions of the ASME, Vol 12, pp A159-A165, 1945.
2. Manson, S. S. International Journal of Fracture Mechanics, Vol 2, No. 1, p 327, 1966.
3. Coffin, L. F., American Society for Testing and Materials STP 520, Vol 5, 1973.
4. Tavernelli, J. F., and L. F. Coffin, Jr., "A Compilation and Interpretation of Cyclic Strain Fatigue Tests on Metals," Transactions of the ASM, Vol 51, p 438, 1958.
5. Mason, W. P., "Internal Friction and Fatigue in Metals at Large Strain Amplitudes," Journal of the Acoustical Society of America, Vol 28, No. 6, p 1207, 1956.
6. Granato, A., and K. Lucke, "Theory of Mechanical Damping Due to Dislocations," Journal of Applied Physics Vol 27, No. 6, p 583, 1956.
7. Feltner, C. E., and J. D. Morrow, "Microplastic Strain Hysteresis Energy as a Criterion for Fracture," Journal of Basic Engineering, Vol 83, No. 1, p 15, 1961.
8. Martin, D. E., "An Energy Criterion for Low-Cycle Fatigue," Journal of Basic Engineering, Vol 83, No. 4, p. 565, 1961.
9. Germain, P., Q.S. Nguyen, "Continuum Thermodynamics," Journal of Applied Mechanics, Vol 50, pp 1010-1020, 1983.
10. Lavenda, B. H., Thermodynamics of Irreversible Processes, Macmillan, 1979, Chapters 3 and 4.
11. Callen, H. D., Thermodynamics, Wiley, New York, 1960.
12. Iannece, D., A. Romano, and G. Starita, "An Approach to Thermodynamics of Materials with Fading Memory," Archive for Rational Mechanics and Analysis, Vol 75, No. 4, pp 373-385, 1981.
13. Gurtin, M. E., "Thermodynamics and the Griffith Criterion for Brittle Fracture," International Journal of Solids and Structures, Vol 15, pp 553-560, 1979.
14. Tokuoka, T., "A Thermodynamic Theory of Plasticity Derived from the Clausius-Duhem Inequality," Journal of Thermal Stresses, Vol 5, pp 173-181, 1982.
15. Valanis, K. C., Irreversible Thermodynamics of Continuous Media Internal Variable Theory, Courses and Lectures, International Institute of Mechanical Sciences, Udine, Italy, Springer-Verlag, New York, 1971.

16. Griffith, A. A., "The Phenomenon of Rupture and Flow in Solids," Philosophical Transactions of the Royal Society, London, Vol 221A, pp 163-198, 1920.
17. Valanis, K. C., "An Energy-probability Theory of Fracture (An Endochronic Theory)," Journal De Mechanique, Vol 14, No. 5, pp 844-862, 1975.
18. Burke, K., and F. A. Cozzarelli, "On the Thermodynamic Foundations of Strain-Dependent Creep Damage and Rupture in Three Dimensions," International Journal of Solids and Structures, Vol 20, No. 5, pp 487-497, 1984.
19. McCartney, L. N., "On the Energy Balance Approach to Fracture in Creeping Materials," International Journal of Fracture, Vol 19, pp 99-113, 1982.
20. Inglis, C. E., "Stresses in a Cracked Plate Due to the Presence of Cracks and Sharp Corners," Transactions of Naval Architects, London, Vol 560, p 213, 1913.
21. Irwin, G. R., "Fracture Dynamics" in Fracturing of Metals, American Society for Metals, Cleveland, pp 147-166, 1948.
22. Orowan, E., Energy Criteria of Fracture, Welding Research Supplement, Vol 20, p 1575, 1955.
23. Rice, J. R., "A Path Independent Integral and the Approximate Analysis of Strain Concentration by Notches and Cracks," ASME Journal of Applied Mechanics, Vol 35, pp 379-386, 1968.
24. Liu, H. W., "On the Fundamental Basis of Fracture Mechanics," Engineering Fracture Mechanics, Vol 17, No. 5, pp 425-438, 1983.
25. Erdogan, F., "Stress Intensity Factors," Journal of Applied Mechanics, Vol 50, pp 992-1002, 1983.
26. Hutchinson, J. W. "Fundamentals of the Phenomenological Theory of Nonlinear Fracture Mechanics," Journal of Applied Mechanics, Vol 50, pp 1042-1051, 1983.
27. Gurtin, M. E., "Thermodynamics and the Griffith Criterion for Brittle Fracture," International Journal of Solids and Structures, Vol 15, pp 553-560, 1979.
28. Rice, J. R., "Thermodynamics of the Quasi-Static Growth of Griffith Cracks," Journal of the Mechanics and Physics of Solids, Vol 26, pp 61-78, 1978.
29. Bodner, S. R., D. L. Davidson, J. Lankford, "A Description of Fatigue Crack Growth in Terms of Plastic Work," Engineering Fracture Mechanics, Vol 17, No. 2, pp 189-191, 1983.
30. Izumi, Y., M. E. Fine, and T. Mura, "Energy Considerations in Fatigue Crack Propagation," International Journal of Fracture, Vol 17, NO. 1, pp 15-25, 1981.

31. Badaliance, R., "Application of Strain Energy Density Factor to Fatigue Crack Growth Analysis," Engineering Fracture Mechanics, Vol 13, pp 657-666, 1980.
32. Weertman, J., "Fracture Mechanics: A Unified View for Griffith-Irwin-Orowan Cracks," Acta Metallurgica, Vol 26, pp 1731-1738, 1978.
33. Batte, A. D., W. S. Blackburn, A. Elsenda, T. K. Hellen, and A. D. Jackson, "A Comparison of the J^* Integral With Other Methods of Post Yield Fracture Mechanics," International Journal of Fracture, Vol 21, pp 49-66, 1983.
34. Chudnovskii, A. I., V. A. Dunaevskii, and V. A. Khandogin, "On the Quasi-Static Growth of Cracks," Archives of Mechanics, Vol 30 No. 2, pp 165-174, 1978.
35. Aoki, S., K. Kishimoto, M. Sakata, "Energy-Release Rate in Elastic-Plastic Fracture Problems," Journal of Applied Mechanics, Vol 48, pp 825-829, 1981.
36. Weichert, R., and K. Schonert, "Heat Generation at the Tip of a Moving Crack," Journal of the Mechanics and Physics of Solids, Vol 26, pp 151-161, 1978.
37. Ghonem, H., and J. W. Provan, "Micromechanics Theory of Fatigue Crack Initiation and Propagation," Engineering Fracture Mechanics, Vol 13, pp 963-977, 1980.
38. Provan, J. W., "A Fatigue Reliability Distribution Based on Probabilistic Micromechanics," in Defects and Fracture, Proceedings of the First International Symposium on Defects and Fracture, Tuczno, Poland, (G. C. Sih and H. Zorski, eds.), 1980.
39. Majumdar, B. S., and S. J. Burns, "A Griffith Crack Shielded by a Dislocation Pileup," International Journal of Fracture, Vol 21, pp 229-240, 1983.
40. Hirth, J. P., R. G. Hoagland, and C. H. Popelar, "On Virtual Thermodynamic Forces on Defects and Cracks," Acta Metallurgica, Vol 32, No. 3, pp 371-379, 1984.
41. Kelly, J. M., and P. P. Gillis, "Thermodynamics and Dislocation Mechanics," Journal of the Franklin Institute, Vol 297, No. 1, pp 59-74, 1974.
42. Khannanov, Sh. Kh., "Thermodynamic Approach to the Dislocation Theory of Creep," Physica Metal Metallurgica, Vol 47, No. 1, pp 31-36, 1980.
43. Tanaka, K., and T. Mura, "A Dislocation Model for Fatigue Crack Initiation," Journal of Applied Mechanics, Vol 48, No. 1, pp 97-103, 1981.

44. Barr, D. T., and M. P. Cleary, "Thermoelastic Fracture Solutions Using Distributions of Singular Influence Functions-I," International Journal of Solids and Structures, Vol 19, No. 1, pp 73-82, 1983.
45. Washizu, K., Variational Methods in Elasticity and Plasticity, Pergamon, New York, pp 231-253, 1975.
46. Whiteman, I, R., "A Mathematical Model Depicting the Stress-Strain Diagram and the Hysteresis Loop," Journal of Applied Mechanics, Vol 21, p 95, 1959.
47. Valanis, K. C., "A Theory of Viscoplasticity Without a Yield Surface, Part I: General Theory; Part II: Application to Mechanical Behavior of Metals," Archives of Mechanics, Vol 23, pp 517-551, 1971.
48. Valanis, K. C., and C. F. Lee, "Endochronic Theory of Cyclic Plasticity With Applications," Journal of Applied Mechanics, Vol 51, pp 367-374, 1984.
49. Kanninen, M. F., and C. Atkinson, "Application of an Inclined-Strip-Yield Crack Tip Plasticity Model to Predict Constant Amplitude Fatigue Crack Growth," International Journal of Fracture, Vol 16, No. 1, pp 53-69, 1980.
50. Rolfe, S. T., and J. M. Barsom, Fracture and Fatigue Control in Structures Applications of Fracture Mechanics, Prentice-Hall, New Jersey, pp 14-51, 1977.
51. Prager, W., "Composite Stress-Strain Relations for Elastoplastic Solids," Symposium on Irreversible Aspects of Continuum Mechanics and Transfer of Physical Characteristics in Moving Fluids, (H. Parkus and L. I. Sedov, Eds.), Springer-Verlag, New York, 1968, pp 315-325.
52. Timoshenko, S. P., and J. N. Goodier, Theory of Elasticity, 3rd Edition, McGraw-Hill, New York, p 181, 1970.
53. Sneddon, I. N., and M. Lowengrub, Crack Problems in the Classical Theory of Elasticity, Wiley, New York, p 22, 1969.
54. Whaley, P. W., "A Mathematical Model for Material Damping and Fatigue Damage Based on Random Yielding," Submitted to the ASME Journal of Vibration, Acoustics, Stress, and Reliability in Design, Aug. 1984.
55. Whaley, P. W., P. S. Chen and G. M. Smith, "Measurement of Material Damping During Fatigue Tests," Experimental Mechanics, Vol 24, No. 4, pp 342-348, Dec 1984.
56. LeMay, I., Principles of Mechanical Metallurgy, Elsevier, New York, pp 19-25, 1981.

57. Sih, G. C., and E. T. Moyer, Jr., "Path Dependent Nature of Fatigue Crack Growth," Engineering Fracture Mechanics, Vol 17, No. 3, pp 269-280, 1983.
58. El Haddad, M. H., K. N. Smith, and T. H. Topper, "A Strain Based Intensity Factor Solution for Short Fatigue Cracks Initiating from Notches," Fracture Mechanics, ASTM STP 677, pp. 274-289, 1979.
59. Talug, A., and K. Reifsnider, "Analysis and Investigation of Small Flaws," Cyclic Stress-Strain and Plastic Deformation Aspects of Fatigue Crack Growth, ASTM STP 637, pp.81-96, 1977.
60. Pearson, S., "Initiation of Fatigue Cracks in Commercial Aluminum Alloys and the Subsequent Propagation of Very Short Cracks," Engineering Fracture Mechanics, Vol 7, No. 2, pp. 235-247, June 1975.
61. Grandt, A. F., Jr., "Introduction to Damage Tolerance Analysis Methodology," Damage Tolerance of Metallic Structures: Analysis Methods and Applications, ASTM STP 842, J. B. Chang and J. L. Rudd, Eds., pp3-24, 1984.
62. Powell, B. E., and I. Henderson, "The Conjoint Action of High and Low Cycle Fatigue," AFWAL-TR-83-4119, Dec 1982.
63. Nakai, Y., K. Tanaka, and T. Nakanishi, "The Effects of Stress Ratio and Grain Size on Near-Threshold Fatigue Crack Propagation in Low-Carbon Steel," Engineering Fracture Mechanics, Vol 15, No 3-4, pp 291-302, 1981.
64. Hashin, Z., "Analysis of Composite Materials - A Survey," Journal of Applied Mechanics 50 (1983) 481-505.
65. Dharan, C. K. H., "Fatigue Failure Mechanisms in a Unidirectionally Reinforced Composite Material," Fatigue of Composite Materials ASTM STP 569, American Society for Testing and Materials (1975) 171-188.
66. Johnson, W. S., "Mechanisms of Fatigue Damage in Boron/Aluminum Composites," Damage in Composite Materials ASTM STP 775, K. L. Reifsnider, Ed., American Society for Testing and Materials (1982) 83-102.
67. Highsmith, A. L., and K. L. Reifsnider, "Stiffness - Reduction Mechanisms in Composite Laminates," Damage in Composite Materials ASTM STP 775, K. L. Reifsnider, Ed., American Society for Testing and Materials (1982) 103-117.
68. Fong, J. T., "What is Fatigue Damage?", Damage in Composite Materials ASTM STP 775, K. L. Reifsnider, Ed., American Society for Testing and Materials (1982) 243-266.
69. Wang, S. S., and E. S.-M. Chim, "Fatigue Damage and Regradation in Random Short-Fiber Composite," Journal of Composite Materials 17 (1983) 114-134.

70. Wang, S. S., "Fracture Mechanics for Delamination Problems in Composite Materials," Journal of Composite Materials 17 (1983) 210-223.
71. Bagley, R. L., and P. J. Torvik, "A Theoretical Basis for the Application of Fractional Calculus to Viscoelasticity," Journal of Rheology 27 (1983) 201-210.
72. Jones, R. M., Mechanics of Composite Materials, New York, McGraw-Hill, 1975.
73. Teoh, L. S., and C.-C. Huang, "The Vibration of Beams of Fibre Reinforced Material," Journal of Sound and Vibration 51 (1977) 467-473.
74. Gibson, R. F., "Elastic and Dissipative Properties of Fiber-Reinforced Composite Materials in Flexural Vibration," Unpublished Ph.D. Dissertation, University of Minnesota, 1975.
75. Schultz, A. B., and S. W. Tsai, "Dynamic Moduli and Damping Ratios in Fiber-Reinforced Composites," Journal of Composite Materials 2 (1960) 368-379.
76. Adams, R. D., and D. G. C. Bacon, "Effect of Fibre Orientation and Laminate Geometry on the Dynamic Properties of CFRP," Journal of Composite Materials 7 (1973) 402-428.
77. Steif, P. S., "Stiffness Reduction Due to Fiber Breakage," Journal of Composite Materials, Vol 17, pp 153-172, March 1984.
78. Schapery, R. A., "On Constitutive Equations for Viscoelastic Composite Materials with Damage," Workshop on a Continuum Mechanics Approach to Damage and Life Prediction, Sponsored by NSF, Carrollton, Kentucky (1980) 119-133.
79. Foley, G. E., M. E. Roylance, and W. W. Houghton, "Life Prediction of Glass/Epoxy Composites Under Fatigue Loading," Proceedings, ASME International Conference on Advances in Life Prediction Methods, Albany, New York (1983) 301-305.
80. Ashton, J. E., and J. M. Whitney, Theory of Laminated Plates, Westport, Conn., Technomic Publishing Co. 1970.
81. Pagano, N. J., and R. B. Pipes, "The Influence of Stacking Sequence on Laminate Strength," Journal of Composite Materials 5 (1971) 50-57.
82. Wu, E. M., "Fracture Mechanics of Anisotropic Plates," Composite Materials Workshop, Technomic Publishing Co., Inc., (1968) 20.
83. Gaggar, S., and L. J. Broutman, "Fracture Toughness of Random Glass Fiber Epoxy Composites: An Experimental Investigation," Flaw Growth and Fracture, ASTM STP631, (1977) 310-330.

84. Harris, C. E., and D. H. Morris, "Fracture Behavior of Thick, Laminated Graphite/Epoxy Composites," NASA Contractor Report 3784, March 1984.
85. Shen, W., and J. D. Lee, "The Nonlinear Energy Method for Mixed Mode Fracture," Engineering Fracture Mechanics, Vol 16, No. 6, (1983) 783-798.
86. Ju, F. D., and J. H. Huang, "Thermomechanical Cracking Due to Moving Friction Loads," Report No. ME-125(84)ONR233-2, Final Report on Contract No. ONR-N00014-83-0304, May 1984.

DISTRIBUTION LIST - TRIBOLOGYOne copy except
as noted

Mr. M. Keith Ellingsworth
Engineering Sciences Directorate
Office of Naval Research
800 N. Quincy Street
Arlington, VA 22217

2

Defense Documentation Center
Building 5, Cameron Station
Alexandria, VA 22314

12

Technical Information Division
Naval Research Laboratory
4555 Overlook Avenue SW
Washington, DC 20375

6

Division of Weapons & Engineering
U. S. Naval Academy
Annapolis, MD 21402

D. L. Bonner, LMM
Headquarters, U. S. Marine Corps
Washington, DC 20380

Colonel R. Bowles, USMC
Marine Corps Liaison Officer
Office of Naval Research
800 N. Quincy Street
Arlington, VA 22217

Mr. R. G. Brown
Code 2382
DTNSRDC
Annapolis, MD 21402

Dr. J. Dell POSL 1
Air Force Wright Aeronautical Laboratories
Wright-Patterson Air Force Base
Dayton, OH 45433

M. J. Devine
General Technology
2560 Prescott Road
Havertown, PA 19083

A. J. D'Orazio, Code PE-72
Naval Air Propulsion Center
Trenton, NJ 08628

Mr. Jim Dray
Head, Friction & Wear Branch
DTNSRDC
Annapolis, MD 21402

F. C. Gale
NAVMAT
Code OOKB, CP5, Room 606
Washington, DC 20360

Mr. Richard R. Graham, II
Code 5243, Bldg. NC4
Naval Sea Systems Command
Washington, DC 20362

Mr. Al Harbage, Jr.
Code 2723 DTNSRDC
Annapolis, MD 21402

Mr. Martin Kandl
Code 5231
Naval Sea Systems Command
Washington, DC 20362

S. Karpe
David W. Taylor Naval Ship
R & D Center
Ship Materials
Engineering Department
Annapolis, MD 21402

Dr. R. N. Katz
Pacific
Army Materials and
Mechanics Research Center
Watertown, MA 02172

Lt. Col. R. Kerr, USMC
Mobility and Logistics
Division Development Center
MCDEC
Quantico, VA 22134

L. Kociuba, Code 92A3
Naval Air Engineering Center
Division
Lakehurst, NJ 08733

A. J. Koury - AIR-4111D
Naval Air Systems Command
Washington, DC 20361

Dr. George Mayer
Director, Metallurgy and
Materials Science Division
Army Research Office
P. O. Box 12211
Research Triangle Park, NC 27709

W. McGovern
U. S. Army MERDC
Fort Belvoir, VA 22060

D. V. Minuti
Code 606B
Naval Air Development Center
Warminster, PA 18974

Dr. Jim D. Murday
Code 6170
Naval Research Laboratory
Washington, DC 20375

Mr. Cliff Mussen
PMS 396-223
Naval Sea Systems Command
Washington, DC 20362

Mr. A. B. Neild, Jr.
Head, Power Transmission Branch
DTNSRDC
Annapolis, MD 21402

NASA-Lewis Research Center
Attn: Mr. Jim Kiraly
21000 Brookpark Road
Cleveland, OH 44135

J. W. Patten
Battelle Memorial Institute

Northwest Laboratories
Richland, WA 99352

Dr. Earl Quandt, Jr.
Head, Power Systems Division
DTNSRDC
Annapolis, MD 21402

Dr. A. W. Ruff
Metal Science and Standards

National Bureau of Standards
Washington, DC 20234

Mr. Ken R. Sasdelli
Code 2723
DTNSRDC
Annapolis, MD 21402

B. D. McConnell - MLBT
Air Force Wright
Aeronautical Laboratories
Wright-Patterson Air Force Base
Dayton, OH 45433

R. Schmidt, AIR-320
Naval Air Systems Command
Aerospace
Washington, DC 20361

Dr. R. Schumaker, AIR-340
Naval Air Systems Command
Washington, DC 20361

David S. Siegel
Code 260
Engineering
Office of Naval Research
800 N. Quincy Street
Arlington, VA 22217

L. Stallings
Code 6061
Engineering
Naval Air Development Center
Warminster, PA 18974

Mr. Richard Strucko
Code 2723
DTNSRDC
Engineering
Annapolis, MD 21402

Dr. N. P. Suh
Massachusetts Institute
of Technology
Department of Mechanical
Engineering
Cambridge, MA 02139

Dr. Fred J. Tribe
Admiralty Marine Technology
Establishment
Holten Heath, Poole, Dorset
U.K. BH166JU

Dr. E. Van Reuth
Defense Advanced Research
Engineering
Project Agency
1400 Wilson Blvd.
Arlington, VA 22209

Dr. Frank Ventriglio
Code 05R14
Naval Sea Systems Command
Washington, DC 20362

Dr. R. D. Arnell
Department of Aeronautical &
Mechanical Engineering
University of Salford
Salford, U.K. M54WT

Professor Ralph A. Burton
Chairman, Mechanical and
Engineering Department
North Carolina State University
3211 Broughton Hall
Raleigh, NC 27650

Professor N. S. Eiss, Jr.
Department of Mechanical
Virginia Polytechnic Institute
and State University
Blacksburg, VA 24061

Professor I. Etsion
Department of Mechanical

Technion, Haifa
Israel

Professor Hasselman
Virginia Polytechnic Institute
Department of Materials
Blacksburg, VA 24061

Professor William F. Hughes
Mechanical Engineering Dept.
Carnegie Mellon University
Pittsburgh, PA 15213

Professor Frederick D. Ju
Bureau of Engineering Research
University of New Mexico
Albuquerque, NM 87131

Professor T. Keith
Department of Mechanical

University of Toledo
Toledo, OH 43606

Professor Francis E. Kennedy, Jr.
Thayer School of Engineering
Dartmouth College
Hanover, NH 03755

P. Wienberg, AIR-5304C
Naval Air Systems Command
Washington, DC 20361

Mr. Edward L. Wiehe
TRW, Inc.
1 Space Park
Redondo Beach, CA 90278

Professor Alan O. Lebeck
Bureau of Engineering Research
University of New Mexico
Albuquerque, NM 87131

Professor Fred F. Ling
Department of Mechanics
Rensselaer Polytechnic Institute
Troy, NY 12131

Professor K. Ludema
Department of Mechanical Engineering
University of Michigan
Ann Arbor, MI 48105

Professor W. Kenneth Stair
Associate Dean for Research
University of Tennessee
Knoxville, TN 37916

Dr. H. Wilsdorf
Department of Materials
University of Virginia
Charlottesville, VA 22901

Batelle Columbus Laboratories
Attn: Dr. Richard Jentgen
505 King Avenue
Columbus, OH 43201

BHRA Fluid Engineering
Attn: Dr. Bernard S. Nau
Cranfield, Bedford
England MK430AJ

Franklin Research Center
Attn: Mr. Harry Ripple
Twentieth & Parkway
Philadelphia, PA 19103

Wear Sciences
Attn: Mr. Marshall Peterson
925 Mallard Circle
Arnold, MD 21012

Westinghouse R & D Center
Attn: Dr. Ian McNab
1310 Beulah Road
Pittsburgh, PA 15235

END

FILMED

4-85

DTIC