

MICROCOPY RESOLUTION TEST CHART
NATIONAL BUREAU OF STANDARDS-1963-A



**US Army Corps
of Engineers**
Construction Engineering
Research Laboratory

CEERL

Technical Report P-152
April 1984

②

**A PRACTICAL SYSTEM FOR COLLECTING RELIABLE DATA
ON THE SPACE-TIME BEHAVIOR OF PEOPLE**

AD-A151 174

by
Robert M. Dinnat
Aaron J. Averbuch

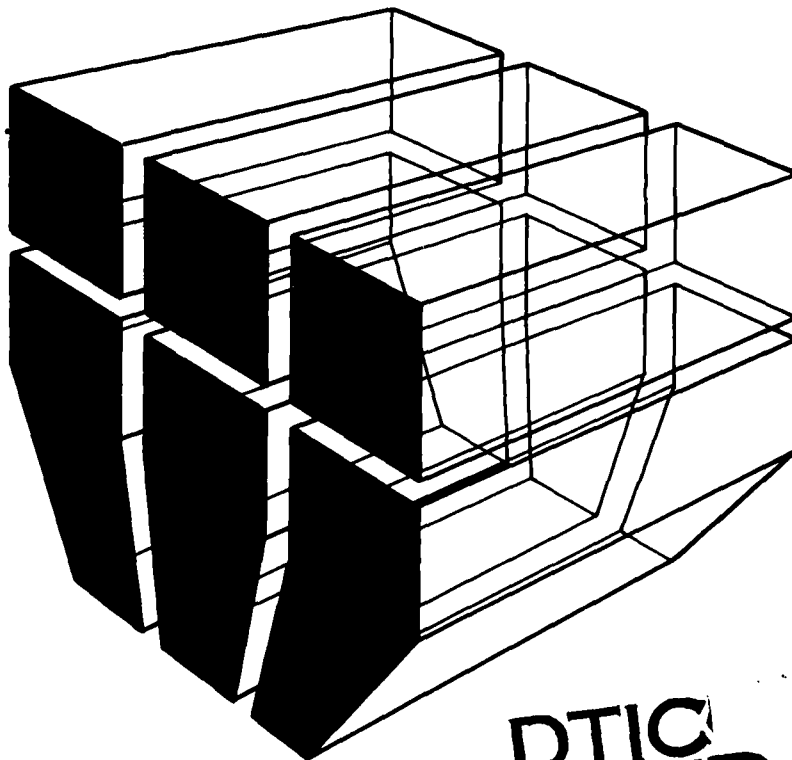

DTIC FILE COPY

Approved for public release; distribution unlimited.

DTIC
ELECTE
MAR 13 1985
S E D

85 03 01 001

The contents of this report are not to be used for advertising, publication, or promotional purposes. Citation of trade names does not constitute an official indorsement or approval of the use of such commercial products. The findings of this report are not to be construed as an official Department of the Army position, unless so designated by other authorized documents.

***DESTROY THIS REPORT WHEN IT IS NO LONGER NEEDED
DO NOT RETURN IT TO THE ORIGINATOR***

UNCLASSIFIED

SECURITY CLASSIFICATION OF THIS PAGE (When Data Entered)

REPORT DOCUMENTATION PAGE		READ INSTRUCTIONS BEFORE COMPLETING FORM
1. REPORT NUMBER CERL-TR-P-152	2. GOVT ACCESSION NO.	3. RECIPIENT'S CATALOG NUMBER
4. TITLE (and Subtitle) A Practical System for Collecting Reliable Data on the Space-Time Behavior of People		5. TYPE OF REPORT & PERIOD COVERED FINAL
		6. PERFORMING ORG. REPORT NUMBER
7. AUTHOR(s) Robert M. Dinnat Aaron J. Averbuch		8. CONTRACT OR GRANT NUMBER(s)
9. PERFORMING ORGANIZATION NAME AND ADDRESS U.S. Army Construction Engr Research Laboratory P.O. Box 4005 Champaign, IL 61820		10. PROGRAM ELEMENT, PROJECT, TASK AREA & WORK UNIT NUMBERS A91D-04-082 AT23-A-019
11. CONTROLLING OFFICE NAME AND ADDRESS		12. REPORT DATE April 1984
		13. NUMBER OF PAGES 21
14. MONITORING AGENCY NAME & ADDRESS (if different from Controlling Office)		15. SECURITY CLASS. (of this report) UNCLASSIFIED
		15a. DECLASSIFICATION/DOWNGRADING SCHEDULE
16. DISTRIBUTION STATEMENT (of this Report) Approved for public release; distribution unlimited.		
17. DISTRIBUTION STATEMENT (of the abstract entered in Block 20, if different from Report)		
18. SUPPLEMENTARY NOTES Copies are obtainable from the National Technical Information Service Springfield, VA 22161		
19. KEY WORDS (Continue on reverse side if necessary and identify by block number) space-time behavior time studies motion studies		
20. ABSTRACT (Continue on reverse side if necessary and identify by block number) ✓ Space-time behavior is determined by collecting data on people's move- ments and inferring a mathematical form which expresses their position in space with respect to time. Analysis of space-time behavior can potentially be useful to the military for training, security, and the planning and design of facilities for military installations. Data on time-space behavior is nor- mally collected by human observers (usually by self-observation); therefore, its reliability is virtually impossible to determine. However, by replacing		

UNCLASSIFIED

SECURITY CLASSIFICATION OF THIS PAGE(When Data Entered)

human operations with electronic operations, the major source of unpredictable error is eliminated.

A conceptual system consisting of individual transmitters and receiver-recorders had been proposed to replace human operations with electronic operations for the collection of data on time-space behavior. This investigation examined the technical feasibility of this concept by testing a simple prototype system. The system was shown to be technically feasible, as well as simple to use, flexible, and affordable.

UNCLASSIFIED

SECURITY CLASSIFICATION OF THIS PAGE(When Data Entered)

FOREWORD

This research was begun in 1981 under funding A91D-04, "Independent Laboratory In-House Research Program," Work Unit 082, "Development of a Concept and System for Collecting Reliable Data on Time-Space Behavior of People." In 1982, the work was funded under project AT23, "Basic Research"; Task Area A, "Technology for Military Facilities"; Work Unit 019, "Technological Feasibility of an Electronic System to Monitor Human Traffic in a Working Environment."

The work was performed by the U.S. Army Construction Engineering Research Laboratory (CERL).

COL Paul J. Theuer is Commander and Director of CERL, and Dr. L. R. Shaffer is Technical Director.

Accession For	
NTIS GRA&I	<input checked="" type="checkbox"/>
DTIC TAB	<input type="checkbox"/>
Unannounced	<input type="checkbox"/>
Justification	
By	
Distribution/	
Availability Codes	
Dist	Avail and/or Special
A-1	



CONTENTS

	<u>Page</u>
DD FORM 1473	1
FOREWORD	3
1 INTRODUCTION.....	5
Background	
Objective	
Approach	
Scope	
2 THE CONCEPTUAL SOLUTION.....	7
3 EQUIPMENT AND TESTING PROCEDURES.....	10
The Prototype System	
Testing Procedure	
4 RESULTS AND ANALYSIS.....	15
Reliability	
Accuracy	
Validity	
Affordability	
Simplicity	
Flexibility	
5 POTENTIAL APPLICATIONS.....	18
Military Facilities	
Design Research	
Training	
Security	
6 CONCLUSIONS AND RECOMMENDATIONS.....	21
DISTRIBUTION	

A PRACTICAL SYSTEM FOR COLLECTING RELIABLE DATA ON THE SPACE-TIME BEHAVIOR OF PEOPLE

1 INTRODUCTION

Background

Space-time behavior is defined as the position in space of one or more individuals expressed as a function of time. It is determined by collecting data on people's movements and inferring a mathematical form which expresses their position in space with respect to time. Such data can be useful to the military for planning and designing facilities, design research, training, and security operations.

Several techniques are used to collect this type of space-time behavior data. These techniques can be divided into two groups: electronic distance measuring techniques and visual field techniques.

An electronic distance measuring technique determines the straight-line distance between two points by measuring the time required for an electromagnetic wave of known frequency to travel between the points. A triangulation scheme is the most common way of using this technique to determine space-time behavior. A typical scheme places a transmitter-receiver at one fixed point and receivers at one or more other fixed points; their positions and the distances between them are known. The individual collecting the data carries a transponder which, when activated by a signal from the transmitter, sends out a return signal. The time between transmission and receipt of the return signals determines the distance from the individual to each receiver. The locations of the individual and any two receivers form a triangle. Since the distance between any two receivers is known, the lengths of all three sides of the triangle are known; hence, trigonometry can be used to find the directions and distances from the individual's position to the known positions of the receivers.

The visual technique determines position by identifying when a monitored person enters a field of view of known location. Two different approaches are used: either the monitored person observes and records his/her own space-time behavior, or another person does it. In either approach, the field of view may also be observed and recorded automatically by movie or television cameras.

A technically ideal data collection system provides data which are valid, reliable, and accurate. A practically ideal system is affordable, flexible enough to adapt to different requirements, and simple to install, operate, and dismantle. No system possesses all of these attributes to a degree sufficient for use in many current applications of space-time behavior studies. The electronic distance measuring techniques provide highly accurate, reliable data. The visual techniques give significantly less accurate and reliable data; however, they are accurate enough for most applications and are at least equal to and generally better than electronic techniques in terms of their validity, affordability, simplicity, and flexibility. Thus, there is a need

for a visual technique which can provide data as accurate and reliable as is provided by an electronic technique.

Objective

The objective of this report is to establish the technical feasibility of a new conceptual system for collecting reliable data on time-space behavior; this system is a visual technique in which all human observation functions would be replaced by electronics.

Approach

A simplified prototype of the conceptual system was designed, constructed, and tested.

Scope

The prototype contained only the features considered necessary to establish its technical feasibility. For example, since different transmission frequencies are suited to different applications, the eventual system will be modularly designed for simple conversion to different frequency ranges. However, the prototype system discussed here was designed and constructed to operate only in the infrared range. Similarly, the final receiver-recorder will have two frequency channels; this prototype system had only one.

2 THE CONCEPTUAL SOLUTION

Electronic distance measuring techniques are more reliable than visual field techniques because they replace human operations in the area of visual techniques. Electronics have also replaced human operations in the area of visual techniques. For example, one system establishes fixed fields of view in a selected number of monitoring locations at known positions and uses television cameras and magnetic tape recorders to observe and record the visual information in each field of view. A human observer monitoring the same location would have to observe the visual field, identify monitored individuals as they entered and exited the field of view, and record their entry and exit times. Furthermore, the observer would have to perform all of these functions in real-time; electronic replacement eliminates this requirement.

The proposed conceptual system performs all of the human observer's functions electronically. It detects and records when a monitored person enters and leaves a monitored location. The system's basic elements are a transmitter and a receiver-recorder. The transmitter replaces the television camera at each monitored location, and the transmission zone replaces the field of view. Each monitored person carries a receiver-recorder which detects when it is in a transmission zone, identifies the zone, and digitally records the zone-identifier and the time when the zone is entered and exited.

Each location to be monitored is established by placing within it a transmitter which broadcasts a unique identification number; the transmission zone determines the area to be monitored. The zone's boundary is established by shaping the transmission beam and/or setting the power level of the transmitter. Figure 1a shows a ceiling-mounted transmitter with a conically shaped transmission zone. The shaded area indicates where the zone strikes the floor.

When the monitored person enters a transmission zone, the receiver-recorder detects and records the transmitter's identification number and the time the zone was entered. When the person leaves the zone, it records the time of exit. Figure 1b is an example of what is recorded during a monitored period. It shows a sequence of events that is recorded as the subject moves around a space containing two monitored locations. As in Figure 1a, the shaded areas indicate where the transmission zones strike the floor. The numbers at the center of the shaded areas are the zone identification numbers. The circled numbers (excluding zero, which indicates the starting point) indicate points along the person's path (indicated by the dashed line) where the recorded data has just been changed; i.e., when the person has just entered or left a monitored location. The information recorded at each such point in the path is shown next to its number in the table at the bottom of Figure 1b. When a zone is entered, the number of the zone and the elapsed time (expressed in seconds) are recorded; when that zone is exited, the number "zero" and the elapsed time are recorded.

As shown in Figure 1b, zone 10 was entered 30 seconds after monitoring began and was exited 90 seconds after it began. Thus, 60 seconds elapsed while the person was in the zone. When zones are adjacent, the person would go directly from one zone into another. However, in this case, only the entry

into the new zone is recorded, since the elapsed time for entry and the exit are the same (see point 4 in Figure 1b).

The monitored zones are separated in Figure 1b. To prevent someone from passing between zones without being detected, there must be an overlap in zones. To avoid the problem of interference in the overlap zone, two different transmission frequencies and a dual channel receiver are used. No more than two frequencies are needed, even when the area is completely covered with monitored zones. Figure 1c shows how this is possible. Each circle represents a monitored area; the letters A and B indicate the two transmitter frequencies, and the numbers identify the zone. As shown in the figure, no overlap zone contains more than two frequencies or two identification numbers.

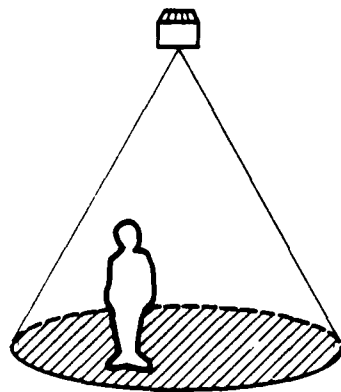

A

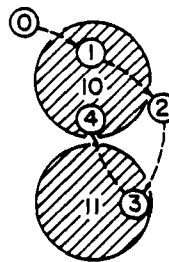

FLOOR PLAN

B

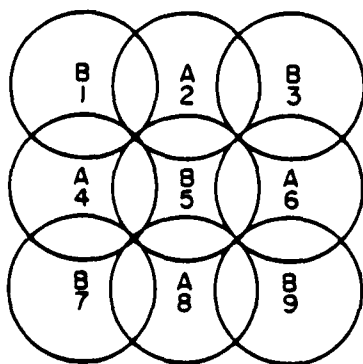

C

RECORDED DATA		
PT	ZONE	ELAPSED TIME
①	00	000
①	10	030
②	00	090
③	11	135
④	10	190

Figure 1. Conceptual system operations.

EQUIPMENT AND TESTING PROCEDURES

e Prototype System

A prototype transmitter and receiver-recorder were designed using state-of-the-art technology. Twenty transmitters and 10 receiver-recorders were constructed.

Transmitter

The transmitter's dimensions are 83 x 118 x 187 mm; the power-pack occupies most of this space. The transmitter contains four alkaline "D" cells, a circuit board, and a light-emitting diode mounted in the cover. The transmission is pulsed to minimize power drain. Each pulse is about 100 milliseconds long; the pulse rate can be varied from three pulses per second to one pulse every 32 seconds. When transmitting at the maximum pulse rate in a zone having a 7-m radius, the batteries will last about 12 hours; when transmitting at one pulse per second in a zone having a 2-m radius, they will last about 450 hours. The transmitter operates in the infrared range at 900 nm--a frequency which is invisible to the naked eye. The transmission zone is shaped into a 10-degree cone with a radius (i.e., transmission distance) that can be varied from 0 to 9 m. The transmission radius is varied by changing the power level. The actual radius is determined by the lowest level at which the receiver-recorder can detect the transmitted signal.

Figure 2 shows a block diagram of the prototype transmitter. The diagram shows the identification numbers of the chips used in each block. Anyone with knowledge of electronics can readily understand the operation of most blocks by reading the label and the chip identification number; however, the Parity Generator and Sequence Logic blocks require further discussion.

The input to the Parity Generator block is a seven-bit binary number which identifies the transmitter. If the binary number contains an even number of zeros, the output parity bit is a zero; if the number contains an odd number of zeros, the output parity bit is a one.

The Sequence Logic block controls the transmitter operation. The sequence of operations starts with the transmitter in a standby state. Transmission is initiated by a signal from the Repetition Rate Binary Counter block, which controls how often the transmitter operates. When the signal to initiate transmission is received, the Sequence Logic block initiates the loading of the transmitter number and the parity bit into the shift register and initiates transmission of the carrier frequency. Modulating the carrier then initiates data transmission. The initial data is a continuous string of bits all equal to one. This transmission is to allow time for the receiver's automatic gain control to stabilize before the transmitter number and parity bit is initiated, followed by continuous transmission of a string of ones again. This time, the purpose is to allow time for the central processing unit in the receiver-recorder to process valid data before the transmitter is returned to the standby state. Finally, the return to the standby state occurs.

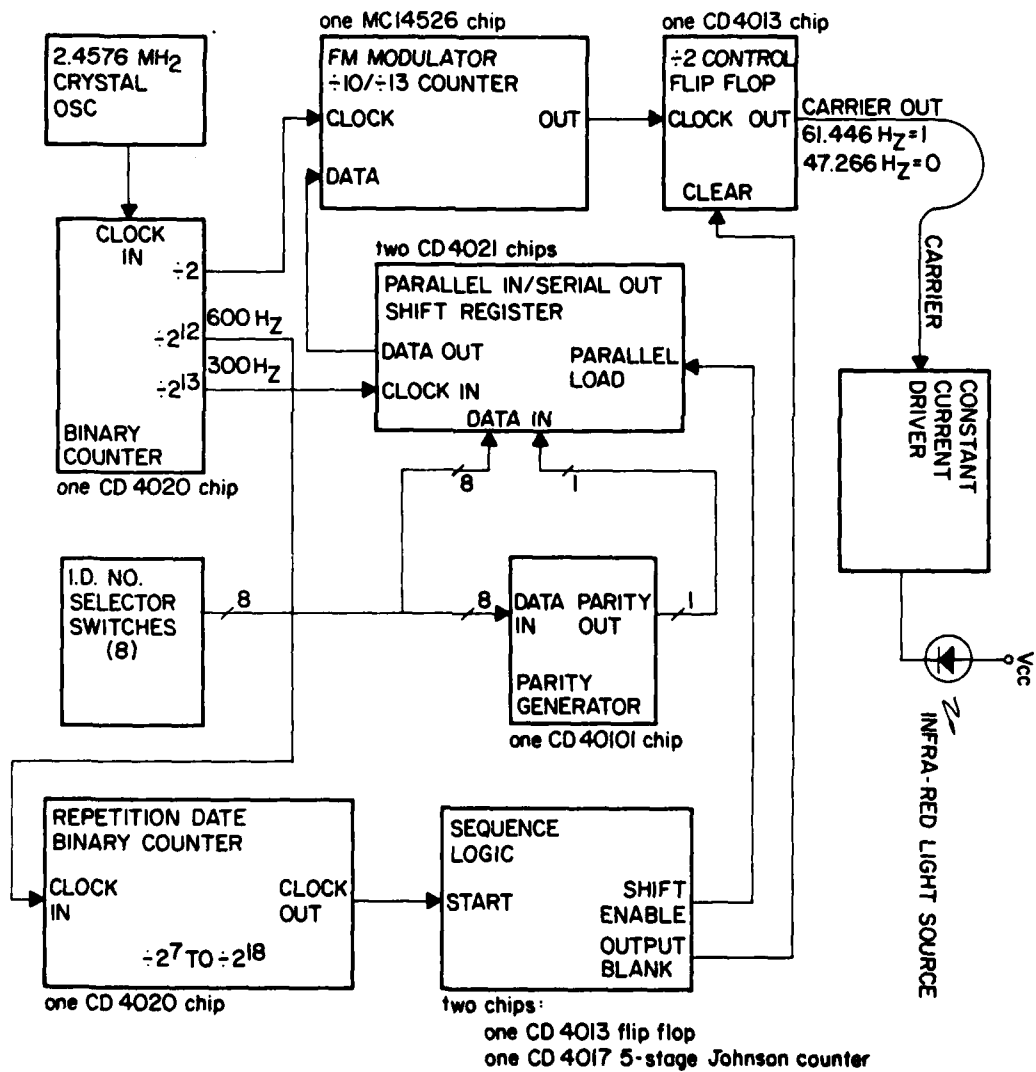

Figure 2. Transmitter diagram.

The Receiver-Recorder

The receiver-recorder is 20 x 100 x 185 mm, a size that can be placed in a shirt pocket. The sensor is separate and is connected to the receiver-recorder by a coaxial cable. It attaches to the clothing and is usually placed on top of the shoulder. The receiver-recorder operates continuously and can receive data as fast as 10 transmissions per second. It is powered by four alkaline "AAA" cells and can operate for about 120 hours.

The output of the receiver-recorder can be read directly into a digital computer for processing or, through a converter, into a standard ASCII computer terminal for printout. The data can be read out as many times as desired. The memory of the receiver-recorder is reset to zero only when the power is shut off. An RS-232 converter is used to print out the data on a terminal, which operates at 300 baud. The terminal printout would show the last two columns of the table (minus the headings) in Figure 1b; however, the first line would not show zeros, but rather the identification number of the receiver and the elapsed time when the printout was made.

Figure 3 is a block diagram of the prototype receiver-recorder. The diagram shows the identification number of the chips used in each block. Anyone with a knowledge of electronics can understand the operation of most blocks; however, several require further comment. The Central Processing Unit (CPU) block controls the operation of the receiver-recorder. Figure 4 is a flow-chart of the program in the CPU. Most of the boxes in this chart are self-explanatory; however, two require additional explanation. Following the YES path from the "data available?" box and the NO path from the "error?" box leads to a box labeled "same data 3 times?". The purpose of this box is to eliminate spurious data generated by other electrical equipment. The other box requiring further explanation is the "clear to send?" box. First, however, further discussion is needed on the Universal Asynchronous Receiver/Transmitter block shown in Figure 3. The transmitter portion of this block transfers the collected data from the memory block to an external computer or computer terminal. That signal is called the "clear-to-send signal." In Figure 4, the purpose of the "clear to send?" box is to transfer data to an external device upon request.

Testing Procedures

The objective of the testing was to establish the reliability of the system under real conditions of data collection. Data were collected on the time-space behavior of selected personnel at the U.S. Army Construction Engineering Research Laboratory. The laboratory hallways were used as the test bed.

Two experimental procedures were used. In one, the monitored personnel were asked to walk a fixed path through the hallways; in the other, they were asked to follow their usual working routines and keep a personal log of any trips in which they used the hallways. The experiments were repeated until enough were collected for a valid statistical analysis.

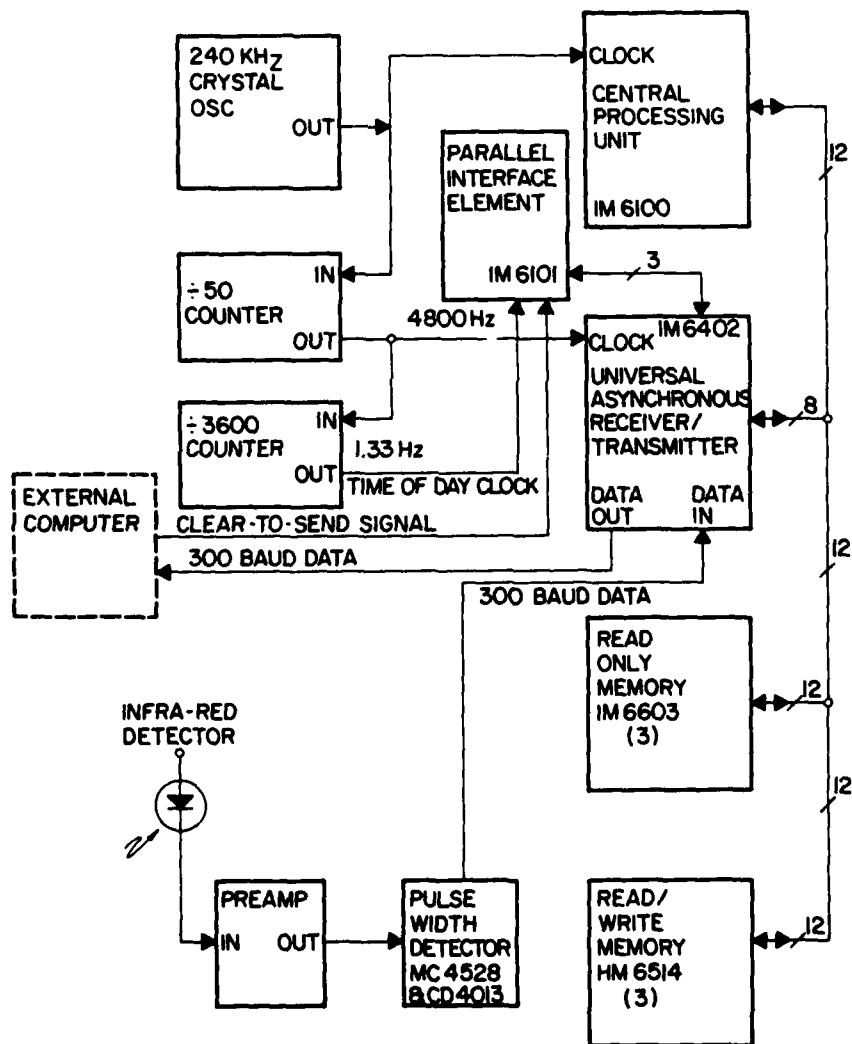

Figure 3. Receiver-recorder diagram.

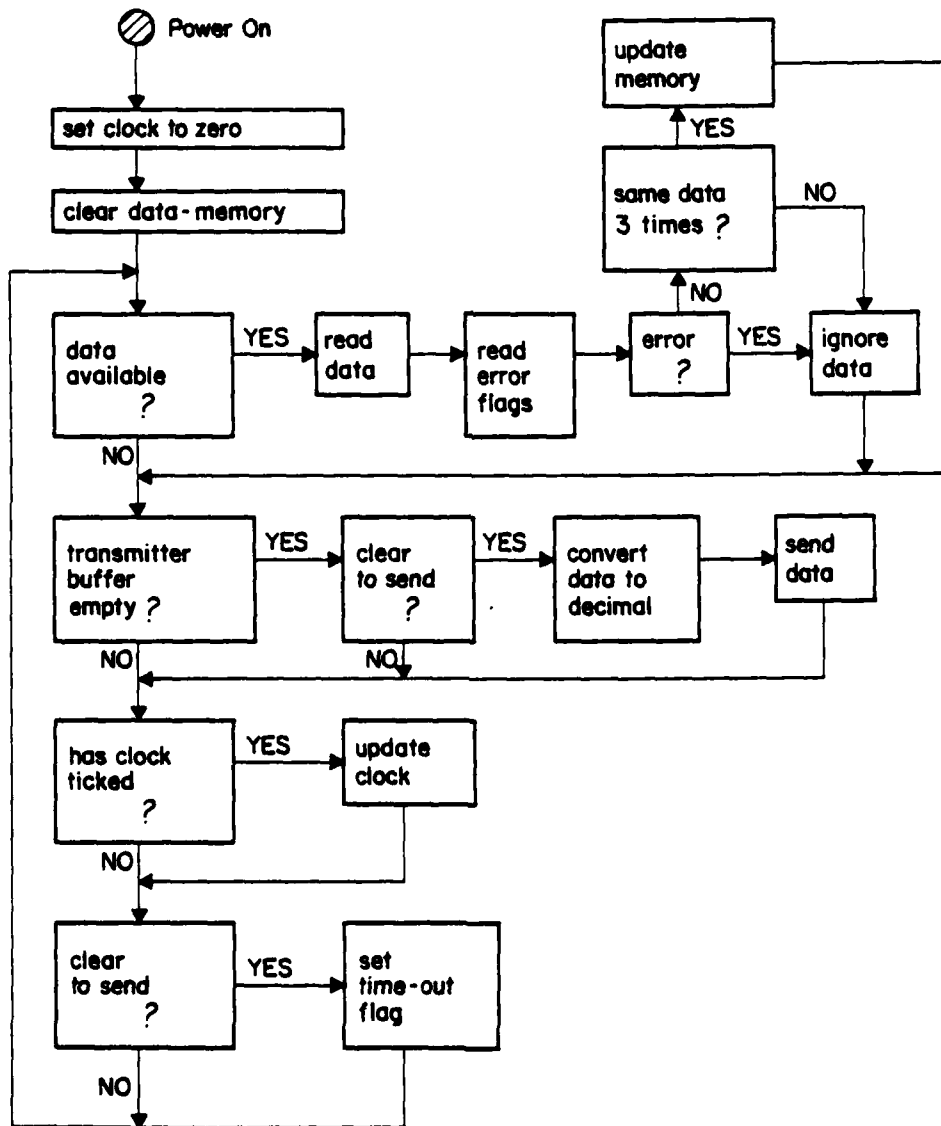

Figure 4. Flowchart of CPU operations.

4 RESULTS AND ANALYSIS

The prototype was tested for attributes of an ideal data collection system: reliability, accuracy, validity, affordability, simplicity, and flexibility. Reliability was the attribute of primary concern.

Reliability

The major problem was spurious data caused by other electrical equipment. In the first of the fixed-path-behavior experiments, 25 to 30 percent of the data collected was spurious. The receiver-recorders contained data for transmitter numbers which were not a part of the experiment. Investigation revealed that fluorescent lights caused the problems. The test for a valid number was received twice in a row. When the validity test was changed to three times in a row, the spurious data were reduced to less than 1 percent. This amount of reduction was enough to show that increasing the number of repetitions required in the validity test will reduce spurious data to zero. Since such a low percentage of spurious data would not significantly affect the normal-behavior experiments, no further change was made in the prototype receiver-recorder. Except for the spurious data, the time durations in each zone were 100 percent repeatable within the accuracy limits set by the time between transmissions.

Accuracy

Determining a person's position with a high degree of accuracy is not normally an objective when collecting this type of data; consequently, no special effort was made to maximize the prototype system's spatial resolution. The spatial resolution is controlled by the time between transmissions and the speed at which the person is moving. The transmission zone must be large enough to prevent a person from walking through the zone without receiving a transmission. With the prototype system, the smallest circular zone that could be monitored was 2 to 3 ft in diameter.

Validity

There is no question that the data collected by this system measures space-time behavior. In some applications, there is a question about whether the measured behavior is really the person's normal behavior. For example, awareness of being monitored could cause abnormal behavior. Only if the subject is completely unaware of the monitoring can the investigator be assured that the collected data are completely valid.

With a system that requires the monitored person to carry an instrument, the assurance of normal behavior depends on whether the person will forget that he/she is carrying the instrument. The prototype receiver-recorder is shirt-pocket size, which is comparable to the logbook that monitored persons carry for recording data when they are observing their own space-time behavior.

There is evidence that some persons forget about being monitored when carrying an instrument of this size. During the normal-behavior experiments, the monitored persons carried the receiver-recorder and recorded their own behavior in a logbook. Three of the 10 persons monitored had at least one trip which appeared in the data collected by the receiver-recorder, but did not appear in the logbook data. Other normal-behavior experiments were conducted in which only the receiver-recorders were carried and only self-reporting was used. Comparing the data from these three cases revealed nothing of statistical significance concerning whether data were affected by subject's awareness of the monitoring. However, significant information about awareness of the monitoring appeared when the participants were interviewed after the experiments. When only the receiver-recorder was carried, all 10 participants said that they completely forgot that they were being monitored for long periods of time, even when they were in the hallways. When only self-reporting was used, all 10 admitted to sometimes forgetting about being monitored, but for much shorter periods of time; only one person admitted forgetting one time when traveling in the hallways. Their consensus about why this occurred was that the self-reporting technique required them to perform a task, while the receiver-recorder technique did not.

These experiments indicate that this system obtains data which are at least as valid as, and probably more valid than, the data obtained with the commonly used self-reporting technique. If the size of the receiver-recorder were reduced still further, say to electronic wristwatch size, the likelihood of the person forgetting about being monitored would probably be much greater; such an innovation is entirely possible, given current developments in electronic circuitry and batteries.

Affordability

For the 20 transmitters and 10 receiver-recorders used in this test, the unit costs were \$200 and \$400, respectively. More efficient mass production techniques which are evolving in the electronics industry should decrease these costs even further. Except for their identification numbers, the receiver-recorders are the same for each person monitored, and the transmitters are the same for each location. Thus, the system is ideal for mass production. Furthermore, the number of functions provided on a single commercially available computer chip is continually increasing. In fact, by using a micro-computer chip, which has become commercially available since the prototypes were constructed, and using production runs of 1000 or more, the price of a receiver-recorder could be reduced to \$100, and the price of a transmitter to \$50.

Simplicity

Simplicity refers to the ease with which a system can be used. Establishing a monitored zone is as simple as emplacing a transmitter and setting the value of the transmission radius. The edges of the transmission zone can be determined by a receiver-recorder, which has a small light that goes on when the transmission signal is being received. Operating the system involves only turning the units on and off and changing the batteries frequently enough to insure their freshness. Since all units are identical, a malfunctioning unit

can be replaced with a spare one quickly and easily so that it can be repaired.

Virtually no electronics skill is needed to perform these operations. An undergraduate psychology student set up, operated, and retrieved the instrumentation for all experiments for this test after receiving only 1 hour of training.

Flexibility

Flexibility refers to the system's ability to respond to different data collection situations. As many zones as desired can be set up (assuming that the transmitters are available); these zones can be placed as close together or as far apart as needed. Consequently, a region of interest can be as completely or sparsely monitored as desired. For these experiments, four different transmitter arrangements were used: two in which a few hallways were completely monitored, and two in which all hallways were sparsely monitored. There were no difficulties in setting up for and collecting data in either arrangement.

Another aspect of flexibility is the ability to change the operating range of the transmitters and receivers, although this was not tested in these experiments. The infrared range was selected for the prototype, because the waves in this range are easily reflected. This greatly facilitated the generation of a conical-shaped transmission zone, whose angle could be varied easily. In cases where penetration is required, some other frequency range (e.g., radio) would be used.

5 POTENTIAL APPLICATIONS

This chapter describes some potential applications of the system. The intent of this discussion is to provide an understanding of what the system does and how it can be used, so that the potential users can identify their own specific applications. In simple terms, the transmitter is a device which establishes a zone of space that one wants to monitor. The receiver-recorder is a device carried by a person or a vehicle which can do the following things:

1. Recognize when it is in a monitored zone.
2. Identify which monitored zone it is in.
3. Determine when it enters and exits the identified zone.
4. Remember which monitored zones it was in and when it entered and exited each of them.
5. Recall and convey the remembered information to another device upon request.

Not all of these capabilities are always needed; however, some applications may require additional capabilities. Monitored zones need not have fixed locations; a limited number of transmitters can be carried by persons and/or vehicles.

Military Facilities

One area of application is the planning and design of military facilities. Data on time-space behavior are being collected in origin-and-destination studies of vehicular traffic and in arrival-and-departure (queueing) studies of people or vehicles at various processing points in a servicing facility. For these cases, the new system would simply replace the present, less reliable system of using human observers to collect these data.

This type of data provides a more reliable basis for establishing design requirements and criteria. For most military facilities, the requirements and criteria involving space-time behavior are derived from information obtained from several sources: the recollections and speculations of users, user-representatives, and design professionals; from publications of research results; and from standard practice. The implication is that, if these requirements are satisfied, the functions that the facility supports can be performed adequately; if the criteria are satisfied, the design requirement will be satisfied. If a facility is underdesigned, it is quickly evident in the difficulties that occur in performing certain functions. However, overdesign is not so evident.

The new system can be used to check a facility for overdesign. Overdesign is the result of unneeded requirements or excessive criteria. For example, an architectural requirement that two spaces be close together may result because the designer expects that the occupants of at least one of the spaces will have to make frequent trips to the other space. Whether this

expectation is valid can be checked by collecting data on the space-time behavior of the occupants in the completed facility. A criterion that there be a connecting door between the spaces assures that the requirement of proximity is satisfied. Whether a connecting door is an excessive criterion can be determined by temporarily blocking access and comparing space-time behavior before, during, and after blockage.

Design Research

Another application for the system is research studies to develop better designs. Except when the connecting door is temporarily blocked, the applications discussed in the previous section collect data on naturally occurring time-space behavior. Deliberately blocking the connecting door is an example of a controlled experiment in which a new situation is introduced to determine its impact to the naturally occurring time-space behavior. The knowledge gained can be used to improve the design of future facilities. For example, some knowledge of the time-space behavior during an emergency could be obtained by having an unexpected fire drill during the data collection.

Training

Land navigation is one area of training in which this system could be useful. For training exercises in terrain where the student cannot be observed, the instructor can use the system to find out whether the student reached the designated location. If the student fails to reach that location, it is usually hard for the instructor to determine how to correct the error, since the student probably will not be able to help. The system could be used to monitor the exercise region so that the instructor can tell when, where, and how the student deviated. With a little added capability in the receiver-recorder, it could be used as a training aid; the instructor could then tell the student whether he/she is on course, and if not, give hints about how to get back on course. (The sport of orienteering is another application of the system. A transmitter would mark each spot on the course and the receiver-recorder would document if and when each spot was reached.)

Training exercises in which the objective is to get within a certain distance of the "enemy" without being detected (e.g., scouting) is another possible application of the system. The enemy area can be covered with monitored zones, and the scouts can carry receiver-recorders to document how far they were able to penetrate without detection.

Security

Another potential application is security. An example would be checking whether persons are entering off-limits areas. Off-limits areas can be established as monitored zones; persons to be checked will carry receiver-recorders. Upon leaving, the recorders would be read at a checkpoint to determine whether any off-limits areas were entered and when. In a simpler form, the recorder in the receiver-recorder could be replaced with an alarm that sounded when a restricted zone was entered; in a more complex form, the recorder could be replaced with a transmitter that broadcasts a signal to a security point.

In a still more complex application, the device could be programmed so that the wearer could enter certain restricted areas without broadcasting an alarm. In this form, the devices could also be used as part of an identification system for gaining entry to a restricted area.

6 CONCLUSIONS AND RECOMMENDATIONS

The conceptual system tested in this study for collecting data on space-time behavior is technically feasible. It provides data which are as reliable as those provided by an electronic distance measuring technique. It can monitor circular floor areas as small as 2 to 3 ft in diameter.

The system provides data that are at least as valid, and probably more valid, than those of the commonly used self-reporting method. The validity can be further increased by reducing the size of the receiver-recorder unit. Even at prototype costs, the system is affordable; moreover, since the units are identical, the potential for cost reduction is considerable if the units are mass-produced. The system is extremely flexible and simple to use, requiring virtually no electronic skills of the operator.

It is recommended that this system be developed for specific applications. Because of the potential for cost reduction if the units are mass-produced, it is recommended that as many users as possible be identified before developing a second-generation prototype.

CERL DISTRIBUTION

Chief of Engineers
ATTN: Tech Monitor
ATTN: DAEN-AS1-L (2)
ATTN: DAEN-EC
ATTN: DAEN-ECC
ATTN: DAEN-ECE
ATTN: DAEN-ZCF
ATTN: DAEN-ECR
ATTN: DAEN-RD
ATTN: DAEN-RDC
ATTN: DAEN-RDM
ATTN: DAEN-RM
ATTN: DAEN-ZCZ
ATTN: DAEN-ZCE
ATTN: DAEN-ZCI
ATTN: DAEN-ZCM

FESA, ATTN: Library 22060
ATTN: DET III 79906

DLA ATTN: DLA-WI 22314

CRREL, ATTN: Library 03755

ETL, ATTN: Library 22060

WES, ATTN: Library 39180

Chanute AFB, IL 61868
3345 CFS/DE, Stop 27

lyndall AFB, FL 32403
AFESC/Engineering & Service Lab

NAVFAC
ATTN: RDT&E Liaison Office (6)
ATTN: Sr. Tech, FAC-03T 22332
ATTN: Asst. CDR R&D, FAC-03 22332

NCEL 93041
ATTN: Library (Code L08A)

Defense Technical Info. Center 22314
ATTN: DDA (12)

Engineering Societies Library
New York, NY 10017

National Guard Bureau 20310
Installation Division

US Government Printing Office 22304
Receiving Section/Depository Copies (2)

US Army Env. Hygiene Agency
ATTN: HSHB-E 21010

National Bureau of Standards 20760

Dinnat, Robert M.

A practical system for collecting reliable data on the space-time behavior of people / by Robert M. Dinnat, Aaron J. Averbuch. - Champaign. Ill : Construction Engineering Research Laboratory, 1984.
21 p. (Technical report ; P-152)

I. Motion study - methodology. I. Averbuch, Aaron J. II. Title.
III. Series ; Technical report (Construction Engineering Research Laboratory) ; P-152.

END

FILMED

4-85

DTIC