

12

AD-A149 991

AD

B
R
L

MEMORANDUM REPORT BRL-MR-3388

DESIGN OF AN OPTICAL CLOSED BOMB (OCB)

Didier Devynck

October 1984

DTIC
ELECTE
FEB 11 1985
S B

DTIC FILE COPY

APPROVED FOR PUBLIC RELEASE; DISTRIBUTION UNLIMITED.

US ARMY BALLISTIC RESEARCH LABORATORY
ABERDEEN PROVING GROUND, MARYLAND

84 12 11 080

**Best
Available
Copy**

Destroy this report when it is no longer needed.
Do not return it to the originator.

Additional copies of this report may be obtained
from the National Technical Information Service,
U. S. Department of Commerce, Springfield, Virginia
22161.

The findings in this report are not to be construed as an official
Department of the Army position, unless so designated by other
authorized documents.

The use of trade names or manufacturers' names in this report
does not constitute indorsement of any commercial product.

DISCLAIMER NOTICE

THIS DOCUMENT IS BEST QUALITY PRACTICABLE. THE COPY FURNISHED TO DTIC CONTAINED A SIGNIFICANT NUMBER OF PAGES WHICH DO NOT REPRODUCE LEGIBLY.

UNCLASSIFIED

SECURITY CLASSIFICATION OF THIS PAGE (When Data Entered)

REPORT DOCUMENTATION PAGE		READ INSTRUCTIONS BEFORE COMPLETING FORM
1 REPORT NUMBER MEMORANDUM REPORT BRL-MR-3388	2 GOVT ACCESSION NO. AD-A149 991	3. RECIPIENT'S CATALOG NUMBER
4 TITLE (and Subtitle) DESIGN OF AN OPTICAL CLOSED BOMB (OCB)		5 TYPE OF REPORT & PERIOD COVERED Final
		6 PERFORMING ORG REPORT NUMBER
7 AUTHOR(s) Didier Devynck*		8 CONTRACT OR GRANT NUMBER(s)
9 PERFORMING ORGANIZATION NAME AND ADDRESS US Army Ballistic Research Laboratory ATTN: AMXBR-1BD Aberdeen Proving Ground, MD 21005-5066		10. PROGRAM ELEMENT, PROJECT, TASK AREA & WORK UNIT NUMBERS 1L161102AH43
11 CONTROLLING OFFICE NAME AND ADDRESS US Army Ballistic Research Laboratory ATTN: AMXBR-OD-ST Aberdeen Proving Ground, MD 21005-5066		12. REPORT DATE October 1984
		13 NUMBER OF PAGES 53
14 MONITORING AGENCY NAME & ADDRESS (if different from Controlling Office)		15 SECURITY CLASS (of this report) UNCLASSIFIED
		15a. DECLASSIFICATION/DOWNGRADING SCHEDULE
16 DISTRIBUTION STATEMENT (of this Report) Approved for public release; distribution is unlimited.		
17 DISTRIBUTION STATEMENT (of the abstract entered in Block 20, if different from Report)		
18 SUPPLEMENTARY NOTES *Societe Nationale des Poudres et Explosifs, Centre de Recherches du Bouchet, France *Defense Exchange Scientist, DEA-F-1267		
19 KEY WORDS (Continue on reverse side if necessary and identify by block number)		
20 ABSTRACT (Continue on reverse side if necessary and identify by block number) In order to provide information on the mechanical behavior of gun propellants during combustion, an Optical Closed Bomb (OCB) has been designed. This fixture is to be used in connection with various visualization techniques such as flash radiography and high speed cinematography. Therefore, the OCB includes some parts made of fiber reinforced composite materials.		

TABLE OF CONTENTS

	Page
LIST OF ILLUSTRATIONS	5
I. INTRODUCTION	7
II. DESIGN OF OPTICAL CLOSED BOMB	8
A. Design of the Combustion Chamber	9
P. Other Features	13
III. OPERATIONAL PROCEDURE	17
IV. CONCLUSIONS	18
ACKNOWLEDGEMENTS	19
REFERENCES	20
APPENDIX A	21
DISTRIBUTION LIST	45

DTIC
COPY
INSPECTED
1

Accession For	
NTIS SFARI	<input checked="" type="checkbox"/>
DTIC TAB	<input type="checkbox"/>
Unannounced	<input type="checkbox"/>
Justification	
PER CALL JC	
By _____	
Distribution _____	
Availability Codes	
Dist	Special
A-123	

W/104

LIST OF ILLUSTRATIONS

Figure		Page
1	Assembly Drawing of the Optical Closed Bomb.	10 (OCB)
2	Wall Thickness vs. Maximum Hoop Stress for a	12 Fiber Reinforced Cylinder of 40-mm ID at a Loading Pressure of 200 MPa (30 Kpsi)
3	Schematic of Fiberglass Bomb Section with Steel	14 End Caps
4	Igniter Housing Sleeve for OCB	14
5	Firing Electrode	16

I. INTRODUCTION

Closed bomb testings are a valuable and dependable means of evaluating the ballistic performances that can be expected from a given propellant lot. Moreover, when the propellant involved is a classical tubular or 7-, 19- or 37- perforation grain, reduction techniques using computers have been developed to provide the experimentalists with additional information, such as the burning rate as a function of pressure, from the data recorded during closed bomb firings.¹

Such computations are based upon the fact that, for classical propellants, it may reasonably be assumed that the phenomenon involved is that of parallel combustion, that is to say, the burning rate is the same, at a given time, on every point of the surface of every propellant grain of the charge tested in the closed bomb.

This hypothesis has been shown to give results that allow a satisfactory prediction of the results obtained in actual gun firings. However, the past few years have witnessed the development of new generations of propellants involving new ballistic concepts. Among others, consolidated charges² and Very High Burning Rate (VHBR) propellants³ have shown promising results for enhancing the performance level of guns. Unfortunately, theoretical predictions of the ballistic behavior of these propellants is difficult due to the fact that the previous assumption of parallel combustion is no longer suitable.

Indeed, a consolidated charge is formed by a conglomerate of propellant grains held together by a binder. After such a charge is ignited, it is very likely that the grains will be separated from each other and that the charge will then behave as a conventional charge. But it is most improbable that this phenomenon occurs right at the time the charge is ignited and this means that the form function of the constituent grains is not valid during at least the first instants of the combustion.

¹C. Price, A. Juhasz, "A Versatile User-Oriented Closed Bomb Data Reduction Program (CBRED)," Ballistic Research Laboratory Technical Report No. ARERL-TR-2018, September 1977, AD# A049465.

²I. W. May, A. A. Juhasz, "Combustion Processes in Consolidated Propellants," Ballistic Research Laboratory Memorandum Report No. ARBRL-MR-03108, May 1981, AD# A101163.

³A. A. Juhasz, I. W. May, W. P. Aungst, F. R. Lynn, "Combustion Studies of Very High Burning Rate (VHBR) Propellants," Ballistic Research Laboratory Memorandum Report No. ARBRL-MR-03152, February 1982, AD# A113029.

It is of great importance then to the modelers to determine the different steps of the combustion process in order to establish an empirical form function to be used as code input.

The problem encountered when dealing with VHBR propellants is of an analogous nature. In fact, a VHBR propellant is not a homogeneous material, but rather a heterogeneous mixture of very small particles. To ensure a reproducible and dependable combustion of such a material, it is essential that the surface regression be a controlled process, i.e. that the flame front does not generate a bulk decomposition of the grain or the pellet of propellant but on the contrary proceeds through the grain following a linear law so it can be considered that parallel combustion is the process involved.

Closed bomb testings and weapon firings essentially provide information on the pressure development during propellant combustion. Although a pressure signal can occasionally carry some information concerning the mechanical behavior of the propellant tested, this information is too limited to allow a full understanding of the phenomena involved.

Therefore, an experimental fixture has been designed to allow a visual observation of the combustion process, using flash radiography or high-speed cinematography. This Optical Closed Bomb (OCB) includes some parts made either of fiber-reinforced materials that are translucent and X-ray transparent or simply of optically transparent plastic. This report presents the design requirements and the solutions adopted to meet them. Also presented in the report is the operational procedure for using the fixture.

II. DESIGN OF OPTICAL CLOSED BOMB

The basic requirements for the design of the fixture were listed as follows:

1. Fixture must be composed of a combustion chamber and a surge tank, the volume of which must be large compared to that of the chamber to allow gases to expand and to avoid excessive pressurization of the fixture.
2. Fixture must be capable of accepting a blowout disk between the chamber and the surge tank.
3. Fixture must stand a maximum pressure of 100 MPa (about 15 kpsi) when used with a fiber-reinforced chamber.
4. Chamber must be transparent or translucent for use with high-speed cinematography, and/or X-ray transmitting for use with flash radiography.

5. Fixture must accept at least piezoelectric pressure transducers and the possibility of sidewall mounted strain gages.
6. Fixture must be capable of functioning either as a closed bomb or as a strand burner, i.e. pre-pressurization of fixture must be possible.
7. Fixture must be usable with a variety of propellants and ignition systems.
8. Fixture must include a nozzle between the chamber and the surge tank. Nozzle must be removable so nozzles of various sizes may be inserted in order to permit the pressurization rate to vary from one experiment to another.
9. Fixture must accommodate sample diameter variations. i.e. fixture must be capable of accepting chambers of various sizes.
10. Safe venting of combustion gases must be possible after experiments.

An assembly drawing of the OCB is given in Figure 1 to be used as a reference in the following sections of this report.

A. Design of the Combustion Chamber

Consolidated charges and VHER propellant grains are of cylindrical shape and two diameters are currently available: 12.7 mm (0.5 in.) and 36.6 mm (1.44 in.). Therefore, two different diameters have been selected for the chamber: 15 mm (0.59 in.) and 40 mm (1.57 in.). However, manufacturing constraints may lead to slightly different values. For the bigger diameter chamber, the length-diameter ratio has deliberately been taken equal to 2. This gives a chamber height equal to 80 mm and a volume of about 100 cm³. The chamber of smaller diameter should have the same height so the adjustment required for using X-rays with either chamber can be maintained at a minimum level.

Once the inside diameter of the chamber has been determined, it is possible to calculate the outside diameter using the thick wall pressure vessel formula:

$$\sigma_{\max} = p \frac{b^2 + a^2}{b^2 - a^2} \quad (1)$$

where : σ_{\max} is the maximum value of the hoop stress,
 p is the pressure inside the vessel,
 a is the inside diameter,
 b is the outside diameter.

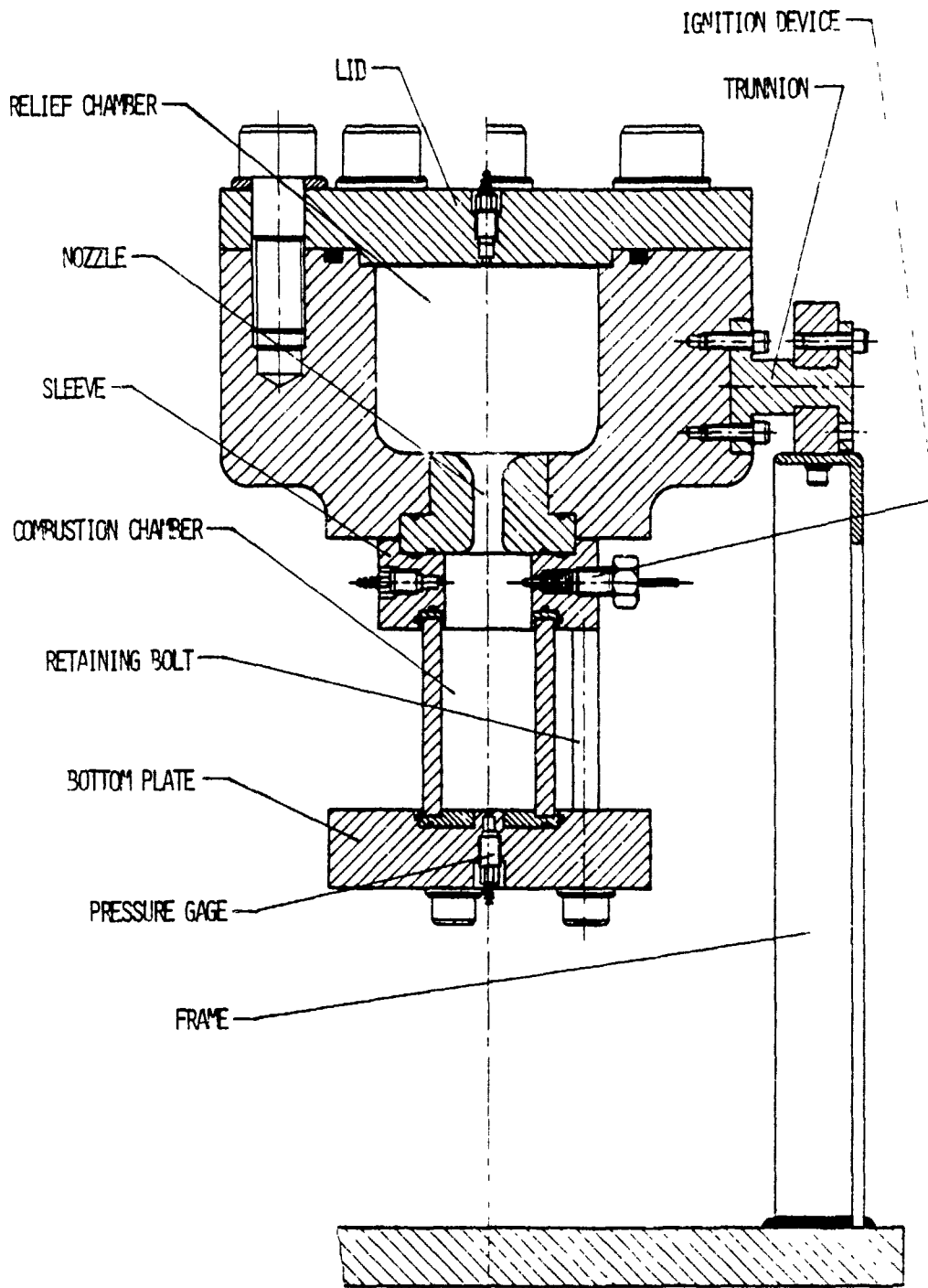

Figure 1. Assembly Drawing of Optical Closed Bomb (OCB)

The hoop stress is a maximum on the inside wall of the chamber. It should also be noted that Eq. (1) is used with the implicit assumption that the wall is composed entirely of a single material. This hypothesis is not quite right in the case presented here since the requirement of X-ray transparency imposes a fiber reinforced composite material as the most suitable solution. Such a material is typically composed of about 75% glass, Kevlar or carbon fibers held by a binder which constitutes the remaining 25% of the material. However, despite a scarcity of experimental data to support this, it is usually considered that the binder plays no significant role in the mechanical strength of the material which is hence treated in theoretical predictions as being only composed of the fiber material.⁴

The curve presented in Figure 2 shows the value of wall thickness as a function of the maximum hoop stress of the fiber material for a given pressure (30 kpsi or about 200 MPa) and an inside diameter of 40 mm.

The maximum stress that can be expected from a filament-wound material depends on the winding angle. A 54-degree wind is the optimum orientation for a thin wall closed pressure vessel where the value of the hoop or circumferential stress is twice that of the longitudinal or axial stress.⁵ Although the chamber has already been considered as a thick wall vessel, and because of an extreme lack of data, the values of the ultimate hoop stress used in the calculations are those obtained for a thin wall vessel and the 54-degree angle by computation from the ultimate tensile properties of the composite in the fiber direction using netting analysis theory.⁵ Those values are: 193,000 psi (1330 MPa) for an S-glass composite and 123,000 psi (850 MPa) for a Kevlar composite.

In these conditions, the chamber wall thickness should be equal to 0.13 in. for a fiberglass chamber and to 0.23 in. when using Kevlar.

In fact, experiments made at the Societe Nationale des Poudres et Explosifs (France) show that a fiberglass chamber, the wind angle of which is 45°, can resist a pressure close to 100 MPa (15 kpsi) with an inside diameter of 30 mm (1.2 in.) and a

⁴H. L. Perritt, "Design and Fabrication of a Kevlar Fiber Composite 30-mm Gun Tube," Naval Surface Weapons Center, Dahlgren Laboratory Technical Report No. NSWC TR 79-251, July 1979.

⁵A. Shibley, H. L. Perritt, M. Fig, "A Survey of Filament Winding PLASTEC," Plastics Technical Evaluation Center, Dover, N.J. Report# 10, May 1962.

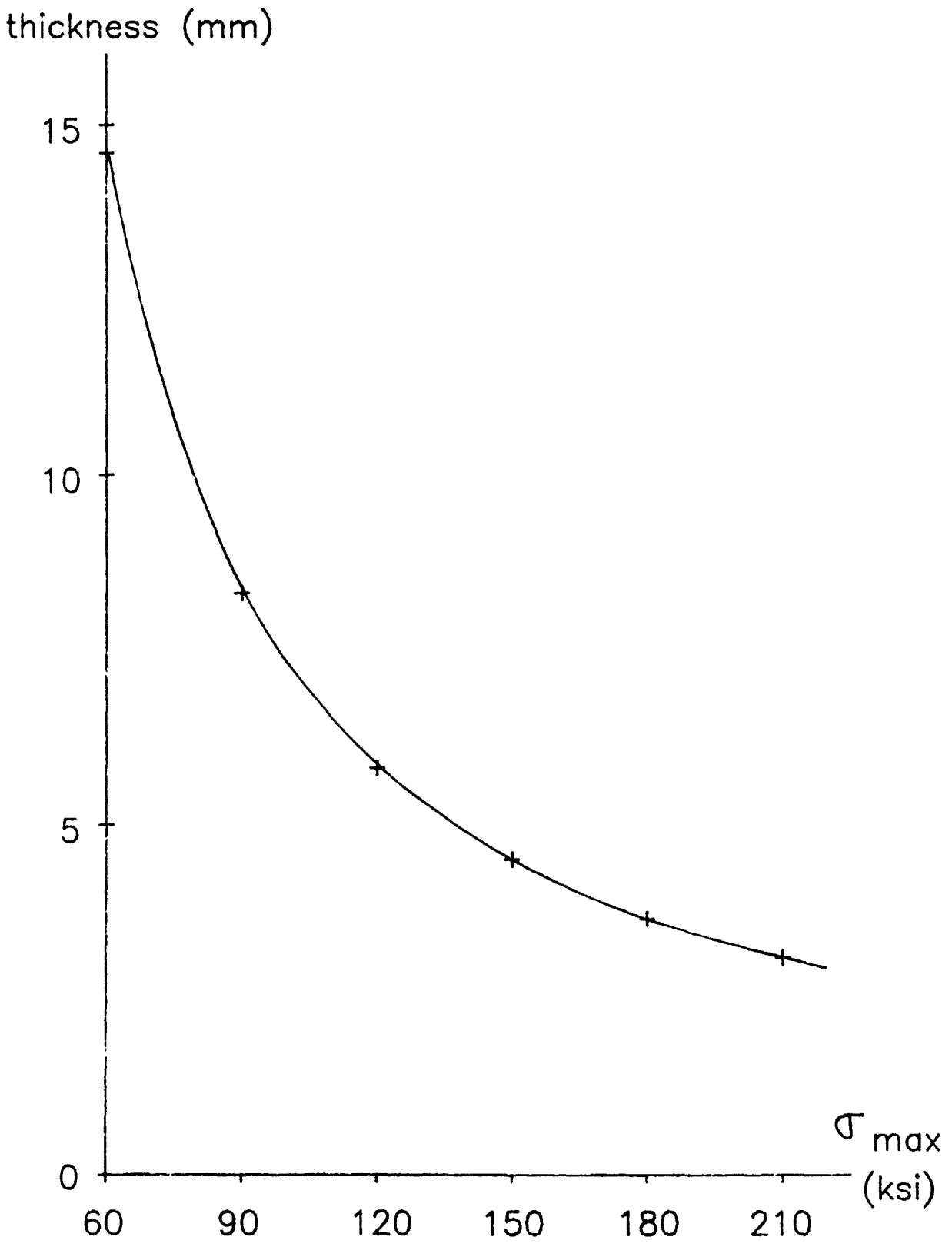

Figure 2. Wall Thickness vs Maximum Hoop Stress for a Fiber Reinforced Cylinder of 40-mm ID at a Loading Pressure of 200 MPa (30 Kpsi)

thickness of 2.35 mm (0.1 in.).⁶ This corresponds to a value of about 700 MPa (100 kpsi) for the maximum stress. This seems to justify the use of the values given above in the calculations.

The ends of the chamber are a very critical point in the design of the chamber. The chamber itself is made of a composite material and sealing has to be accomplished along the surfaces where the composite tube is in contact with the other parts of the chamber. Since the surface of a composite material is rather rough, such a sealing is difficult to achieve.⁶ Therefore, metallic end caps are affixed to the ends of the fiberglass tube by using an epoxy resin which not only holds the caps and the tube together but also prevents leaks (Figure 3). A compressive load on the end caps and the chamber after assembly insures that the epoxy bond is not overstrained. The end caps make possible the use of O-rings to seal the chamber. Moreover, under normal freebody assumptions, the stress at the ends of the chamber would be twice as high as the stress along the chamber sidewall. With this respect, the end caps ensure a clamping of the chamber ends and thus prevent failures due to the end effect.

Once mounted in place, the chamber is squeezed between a bottom plate and the surge tank through four bolts. This number was selected because this configuration is the one which makes easiest the simultaneous use of X-ray and cinematography without having the bolts spaced on a circle of excessive diameter, as it would be the case if a larger number of bolts were used.

B. Other Features

The bottom plate was designed so it is "universal," that is to say, that it can be used with chambers of small or large diameter simply because the end caps are also meant to be adapters. But this design requires that the central part of the bottom plate be of a small diameter and, as a result, there is only room for a pressure transducer on the bottom plate. To house another essential feature, the ignition system, it was then necessary to include in the OCB a sleeve between the chamber and the surge tank (Figure 4). This sleeve is in fact merely an additional portion of the combustion chamber and therefore may not be "universal" since the inside diameter of the sleeve must be the same as that of the chamber.

⁶R. Gerbet, M. Nicolas, J-L. Paulin, "Simulateur pour Visualisation des Phenomenes de Balistique Interieure-Contrat DRE" No. 80/178-Sujet d'Etude No. 2-Note de Synthese," Note Technique No. 167/81/CRB/NP, Societe Nationale des Poudres et Explosifs (France), 22 octobre 1981.

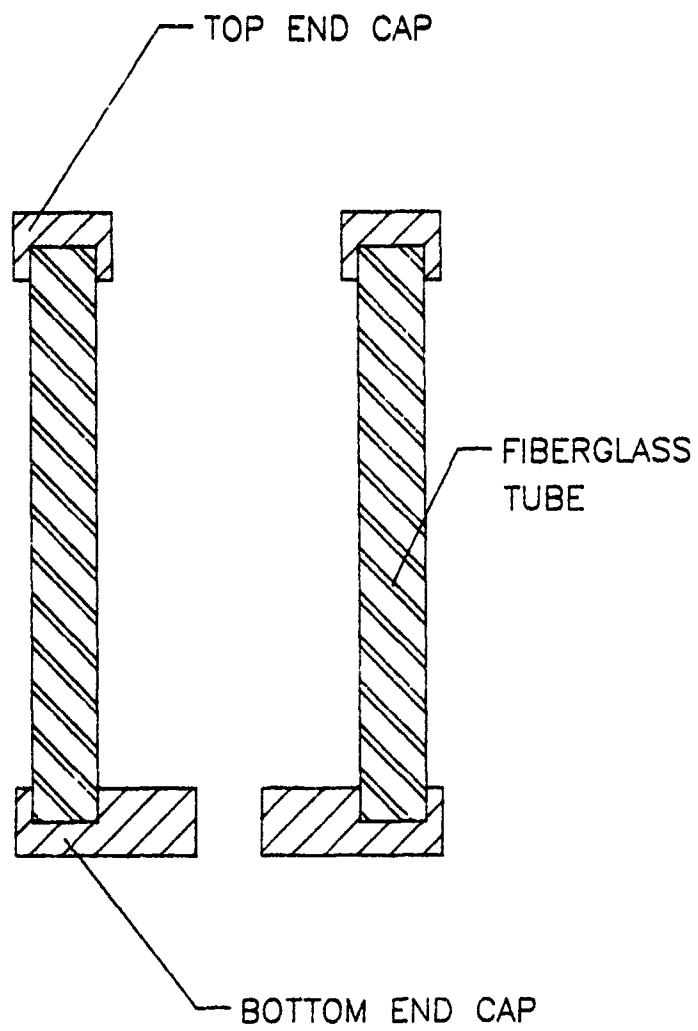

Figure 3. Schematic of Fiberglass Bomb Section with Steel End Caps



Figure 4. Igniter Housing Sleeve for OCR

The firing electrode has to be electrically isolated from the grounded sleeve and, at the same time it has, of course, to offer a secure sealing of the chamber. The solution selected to meet both of these requirements is illustrated in Figure 5. The electrode fits tightly into a Teflon seal which is double-cone shaped so it gets tighter around the electrode when it is squeezed between the housing in the sleeve and a beryllium-copper ring which is pushed against the seal by a threaded plug. The function of the Teflon seal is then double: not only does it ensure isolation and sealing but it also retains the electrode. But, as an additional safety feature, the electrode is divided into an internal and an external part. The two parts are in contact with each other through larger cross-section portions in order to make impossible an accidental ejection of the electrode.

The ground electrode is simply a 1/8-in. diameter metallic wire held in the sleeve by a Swagelok high-pressure fitting.

Also machined in the sleeve are a pressure port designed to fit a 607C-type Kistler gage and a Harwood 4-L recess so a venting valve may be installed. This last feature is intended to allow the venting of the chamber when used with a blowout disk in case neither the chamber nor the disk yield after combustion of the charge, a situation which would result in a dangerous confinement of combustion gases under pressure in the chamber.

As indicated in the list of requirements, and as can be seen on the assembly drawing presented in Figure 1, a nozzle is inserted between the chamber and the surge tank. Along with the bottom plate, the chamber and the sleeve, it is fastened through the four bolts previously mentioned.

Finally, the surge tank itself is but a relief device. Apart from the fact that it must be capable of withstanding the maximum allowable pressure designated for the OCB, its volume must have the proper value to allow a sufficient expansion of the combustion gases. In a closed bomb, a pressure of 15 kpsi is attained for a loading density of about 0.1 g/cm^3 . Hence this is the maximum allowable loading density for the OCB. Consolidated charges with a diameter of 36.6 mm weigh approximately 75 g. (2.65 oz.), which implies that the total volume of the OCB must be equal to about 750 cm^3 when used with the 40-mm diameter (100 cm^3) chamber.

Therefore, considering that some additional volume is generated by the sleeve and the nozzle, a value of 550 to 600 cm^3 has been selected for the surge tank itself. The final inside dimensions for the tank are as follows: 96.5 mm (3.8 in.) in diameter, 78.7 mm (3.1 in.) in height and a 12.7-mm (0.5 in.) radius round edge at the lower part of the tank. These values yield an inside volume of 560 cm^3 (see Figure 1).

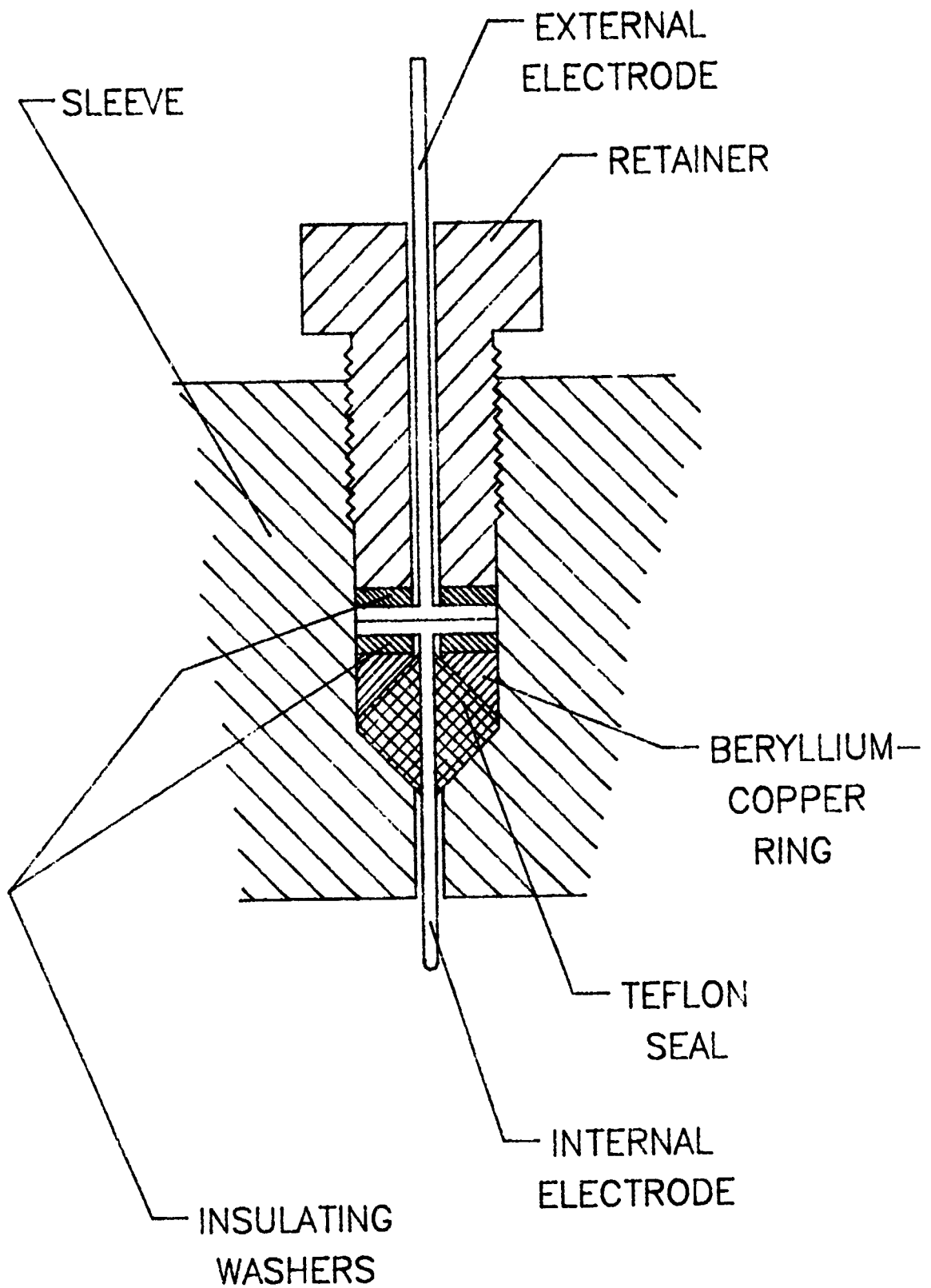

Figure 5. Firing Electrode

The tank is made of 4340 steel which, under given heat treatment conditions, exhibits a yield stress of 225,000 psi (1550 MPa). Using Eq.(1), this value can be used to determine the minimum possible tank wall thickness. The result of such a calculation is 6.6 mm (0.26 in.). In fact, due to practical considerations, a far larger average wall thickness was used (see below).

The tank is closed at the upper end by a lid which must be retained by screws. The sealing is achieved by a 5-in. (127 mm) mean diameter Viton O-ring. At a pressure of 15 kpsi, the force exerted on the lid is then 294,500 lbs. (13,617 N). Because of practical design considerations, the number of screws used must not exceed six. A safety factor of about 2 was taken into account and this leads to the use of six 7/8-in. Allen fine-thread screws which have a total yield strength of 459,000 lbs. (21240 N). The mating threaded holes are machined in the sidewall.

Moreover, three Harwood 4-L recesses are machined in the tank wall so Harwood fittings may be used to vent the combustion gases or to connect the fixture to various devices in order to achieve pre-pressurization and to check the pressure during this operation.

Finally, the OCB is supported by a frame and, to allow the OCB to be used in the horizontal or vertical position, trunnions are used between the fixture and the frame. These trunnions are affixed on the outside tank wall and threaded holes must then be machined in this wall (see Figure 1).

For all those reasons, the tank wall thickness is much larger than that obtained by the above calculation and the final tank outside diameter is 9 in. (228.6 mm).

A complete set of manufacturing drawings for the OCB is reproduced in Appendix A.

III. OPERATIONAL PROCEDURE

Presented in this section are the steps that should be followed for easy and safe handling of the OCB. It must first be noted that a careful cleaning of the whole fixture is absolutely necessary after each experiment and the design was conducted to make it easy.

The first step consists of assembling the chamber. To make this possible, the end caps are previously machined to fit the fiberglass or plastic tube which constitutes the sidewall. The caps may then be affixed to the tube by using an epoxy resin as a glue and by squeezing the assembly between two parallel surfaces during the time necessary for the resin to polymerize.

The assembled chamber is then placed on the firing plate and is thus ready for loading. If the propellant involved in the test exhibits a very high sensitivity to static electricity, as is the case for Hivelite, a thin metallic liner may be inserted along the inside wall of the chamber without any significant consequence on the resulting X-ray picture.

The ignition device is then mounted on the sleeve. In some cases, the propellant grains are packed in a plastic bag and the igniter (electric match + black powder for example) is imbedded in the charge; the whole charge is then mounted on the sleeve. But, when the igniter and the charge are not joined, the charge is placed first in the chamber and the sleeve on top of the chamber if the ignition is desired above the charge. Otherwise, the sleeve is installed first so the igniter is underneath the propellant and the ignition occurs then at the bottom of the charge.

The chamber is then complete and may be mounted at the bottom of the surge tank after the desired nozzle has been inserted in its housing in the tank. The loaded chamber must of course be carried very carefully and the use of a small jack may be helpful to bring smoothly the chamber to its location beneath the tank. The screws or threaded rods are then fastened in the mating threaded holes in the tank and tightened to hold the assembly. If a rupture disk is used, it is important to keep in mind that the venting valve on the sleeve must be kept open when assembling the OCB for firing.

Finally, the OCB is closed by fastening the surge tank lid and the above precaution must still be observed, i.e. the venting valve, on the tank this time, must be kept open during this operation. The final steps of the procedure consist of connecting the ignition device to the firing line and closing the OCB by shutting the valves.

Once the OCB is closed, all operations, namely, pre-pressurization of the OCB (if desired), firing, and venting of the combustion gases, must be remotely conducted until the bomb has been vented after the firing.

IV. CONCLUSIONS

The OCB has been designed to meet a large number of requirements and to be as versatile as possible. It is therefore reasonable to expect that it will be widely used to provide data on the behavior of a propellant during the combustion.

The use of composite materials in the design of the OCB makes possible experiments involving such techniques as flash radiography and high speed cinematography. Since information on this kind of material is very scarce, it is difficult theoretically to predict the performances that can be expected

from the fixture. Only experimental testing will provide the information needed in order to determine the fabrication parameters of the parts made of composite material.

ACKNOWLEDGEMENTS

The author wishes to thank Dr. A. A. Juhasz who proposed the basic idea for the device. Further thanks go to Dr. Juhasz and Dr. K. J. White for helpful suggestions during numerous valuable discussions. Additional thanks go to Mr. W. F. Donovan, whose technical expertise was a priceless help in the achievement of this project. Support and assistance for the completion of this work were also provided by the Societe Nationale des Poudres et Explosifs (France) and the Direction des Recherches Etudes et Techniques (France) by making possible the stay of the author at the Ballistic Research Laboratory.

REFERENCES

- ¹C. Price, A. Juhasz, "A Versatile User-Oriented Closed Bomb Data Reduction Program (CBRED)," Ballistic Research Laboratory Report No. BRL-R-2018, September 1977, AD# A049465.
- ²I. W. May, A. A. Juhasz, "Combustion Processes in Consolidated Propellants," Ballistic Research Laboratory Memorandum Report No. ARBRL-MR-03108, May 1981, AD# A101163.
- ³A. A. Juhasz, I. W. May, W. P. Aungst, F. R. Lynn, "Combustion Studies of Very High Burning Rate (VHBR) Propellants," Ballistic Research Laboratory Memorandum Report No. ARBRL-MR-03152, February 1982, AD# A113029.
- ⁴H. L. Perritt, "Design and Fabrication of a Kevlar Fiber Composite 30-mm Gun Tube," Naval Surface Weapons Center, Dahlgren Laboratory Technical Report No. NSWC TR 79-251, July 1979.
- ⁵A. Shibley, H. L. Perritt, M. Fig, "A Survey of Filament Winding PLASTECH," Plastics Technical Evaluation Center, Dover, N.J. Report# 10, May 1962.
- ⁶R. Gerbet, H. Nicolas, J-L. Paulin, "Simulateur pour Visualisation des Phenomenes de Balistique Interieure-Contrat DRET No. 80/178-Sujet d'Etude No. 2-Note de Synthese," Note Technique No. 167/81/CRB/NP, Societe Nationale des Poudres et Explosifs (France), 22 octobre 1981.

APPENDIX A
MANUFACTURING DRAWINGS
OF THE OCB

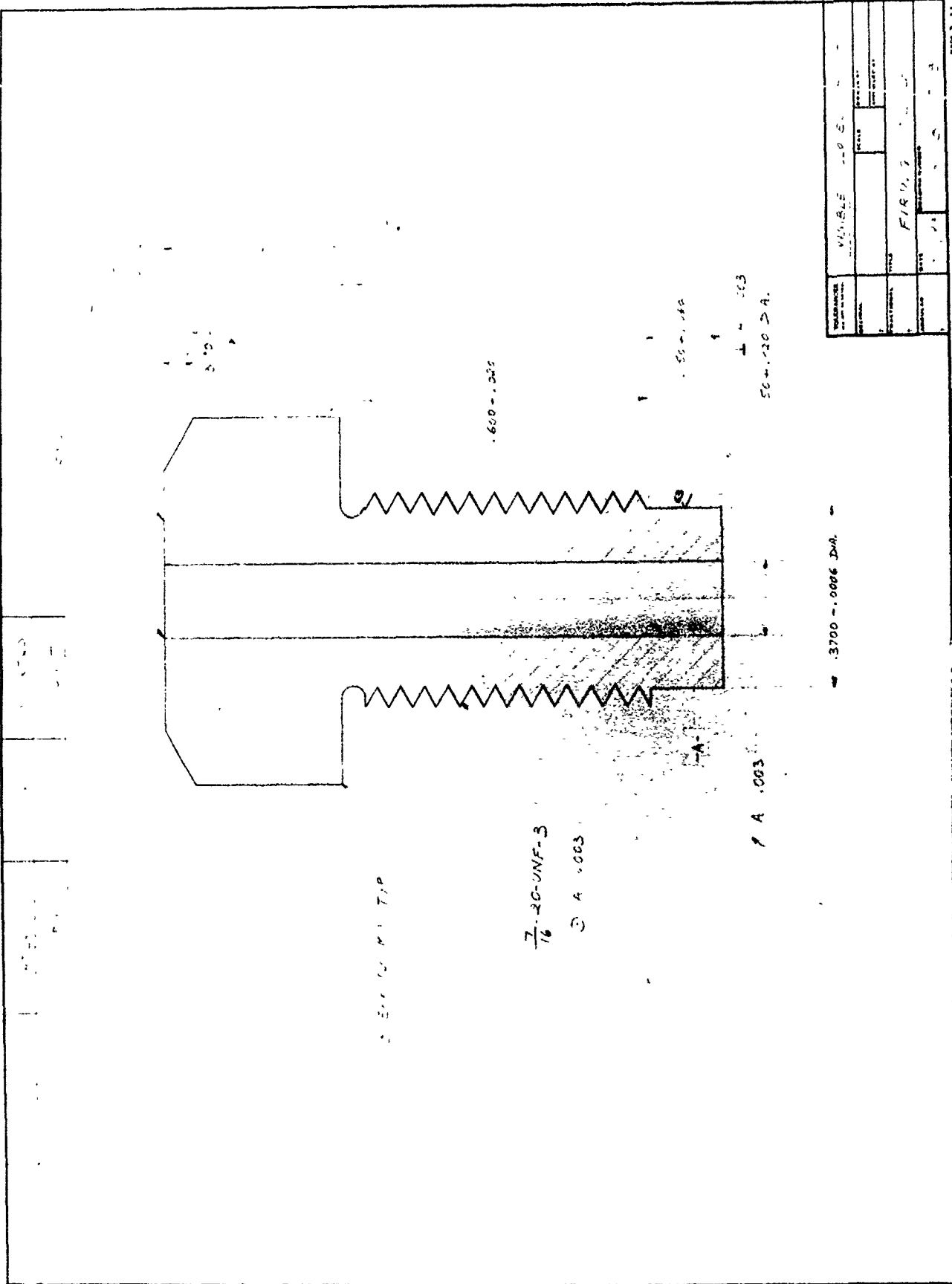

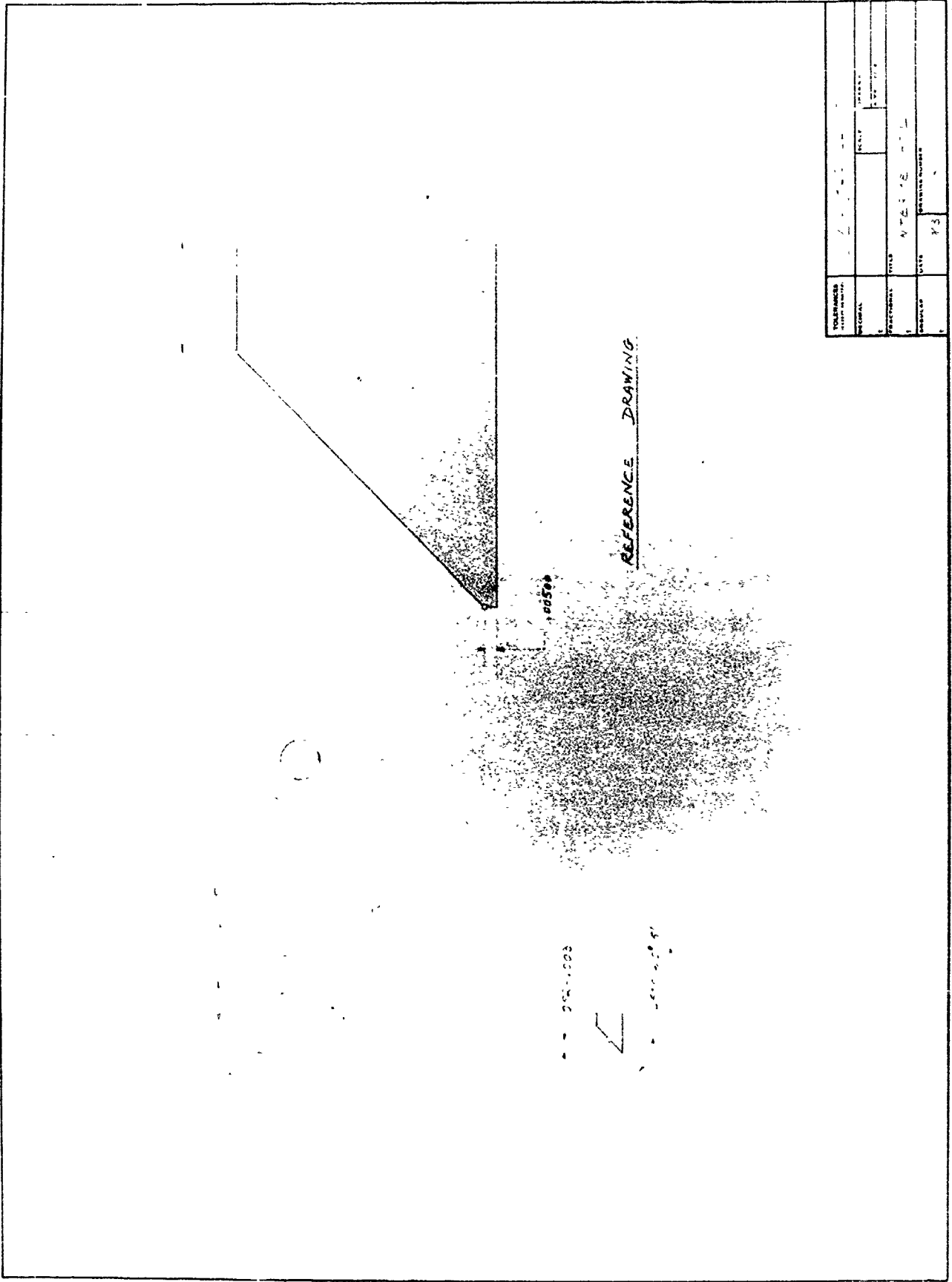

DESIGNER	DATE	SCALE	WORKS
REVISIONS	BY	DATE	REVISION NUMBER
1			
2			
3			
4			
5			
6			
7			
8			
9			
10			

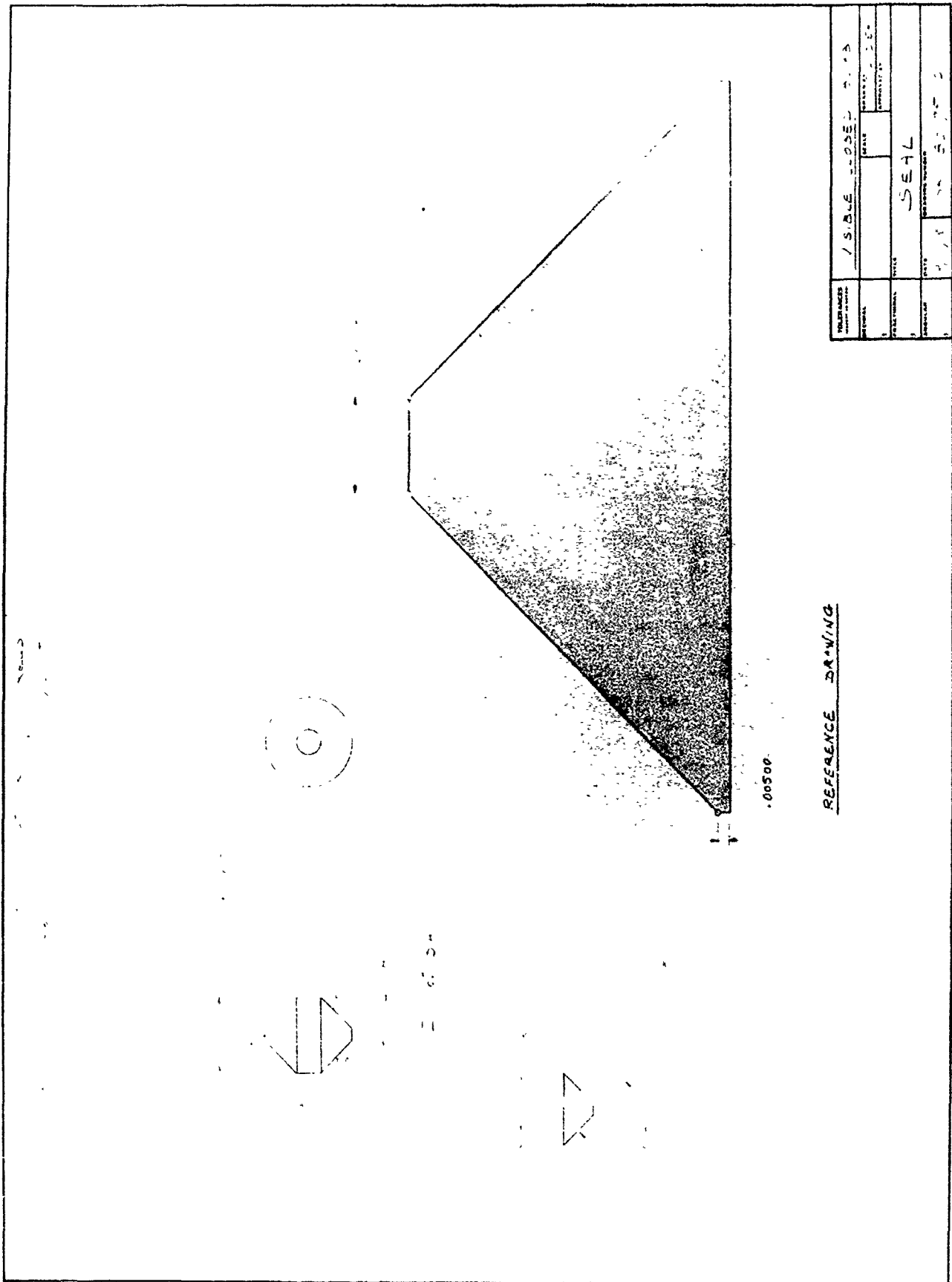

DESIGNER	DATE	SCALE	PROJECT NO.
APPROVED	DATE	SCALE	PROJECT NO.
TITLE SEAL			
PART NO. 51100			

REFERENCE DRAWING

1:1

WORK IN PROGRESS NO. REQD / UNIT	STOCK	MATERIAL 17 4 24
--	-------	---------------------

.010 MAX

BREAK .520 IN. - 12

.005 DIA.

.360 - .000 - 12

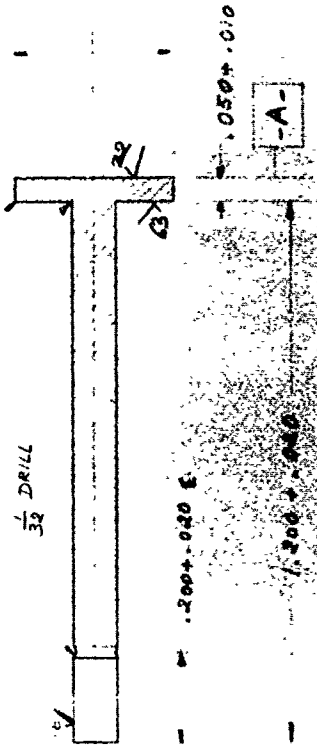

$\frac{1}{32}$ DRILL

.200 ± .020 E

.300 ± .040

.050 ± .010

-A-

TOLERANCES UNLESS OTHERWISE SPECIFIED	VISIBILITY UNLESS OTHERWISE SPECIFIED	SCALE UNLESS OTHERWISE SPECIFIED	DRAWN BY APPROVED BY
DECIMAL	FRACTIONAL	TITLE INTERNAL ELEMENT	DATE 5/1/58
ANGULAR	OPERATING NUMBER	N. C. S.	N. C. S.

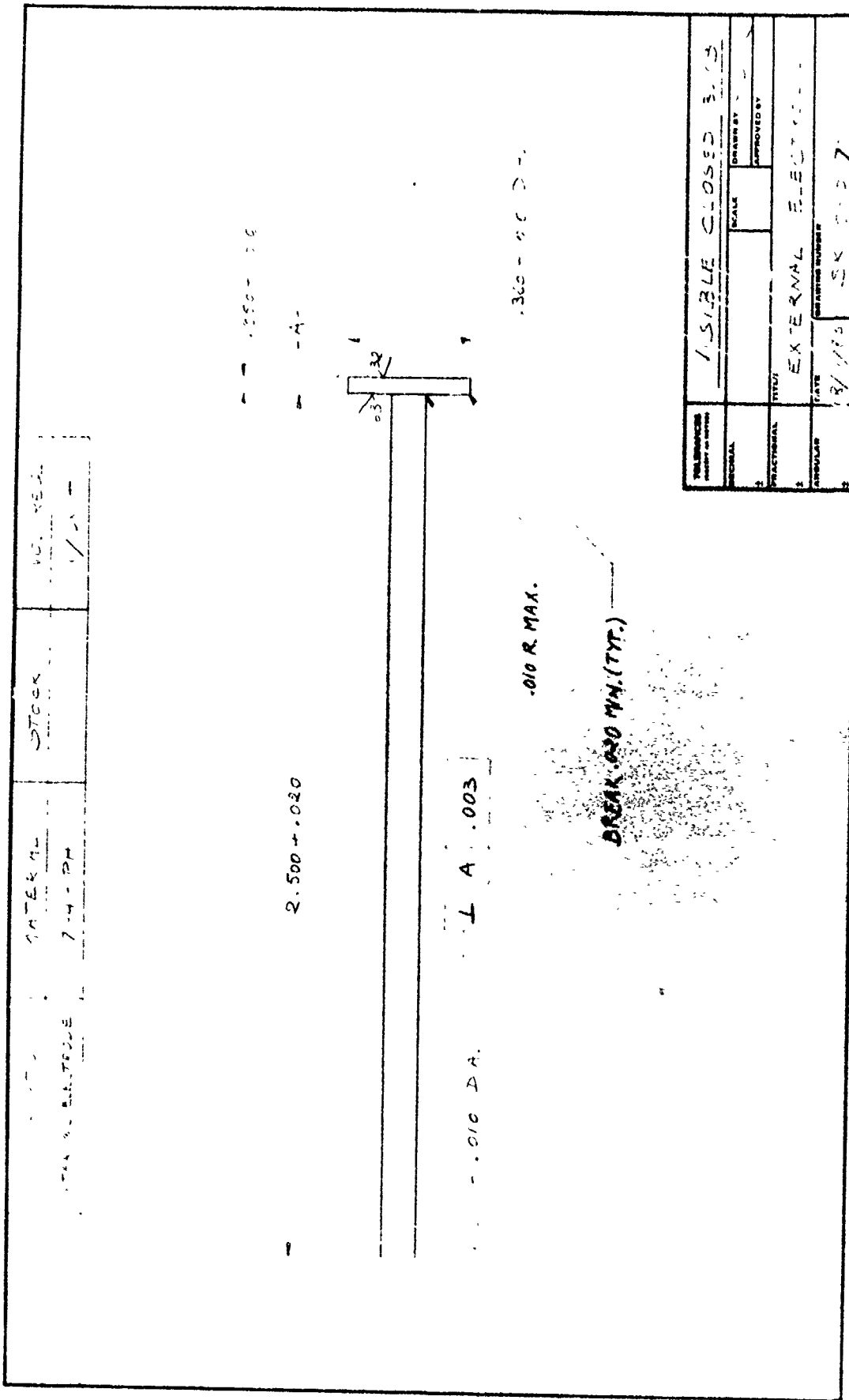

DATE	7-14-74	TIME	7:40 PM
DESIGNED BY	WATERMAN	CHECKED BY	W. W. W.
STOCK		NO. REV.	
		1/1	

UNLESS OTHERWISE SPECIFIED ALL DIMENSIONS ARE IN INCHES		VISIBLE CLOSED ENDS	
1	GENERAL	DATE	12/1/73
2	MECHANICAL	DRAWN BY	
3	ELECTRICAL	APPROVED BY	
4	CHEMICAL	EXTERNAL ELECTRIC	
5	PLUMBING	QUANTITIES NUMBER	
6	OTHER	SK 2007	

MADE IN U.S.A.



500-025 DIA

400-220 DIA

605 RAIN

1005-018

REMOVE ENTRY AND PIN

1-13-UNB

0-1-005

505 MAX

BREAK 105 MAX

1-13-UNB

1005-018

BREAK 105 MAX

1-13-UNB

1005-018

BREAK 105 MAX

1-13-UNB

1005-018

BREAK 105 MAX

1-13-UNB

1005-018

BREAK 105 MAX

1-13-UNB

1005-018

BREAK 105 MAX

1-13-UNB

1005-018

BREAK 105 MAX

1-13-UNB

NOTE: TECHNICAL SURVEYS

1/1 DIA

DATE	11-1-86
TIME	10:30
BY	...
NO.	2-360-1730

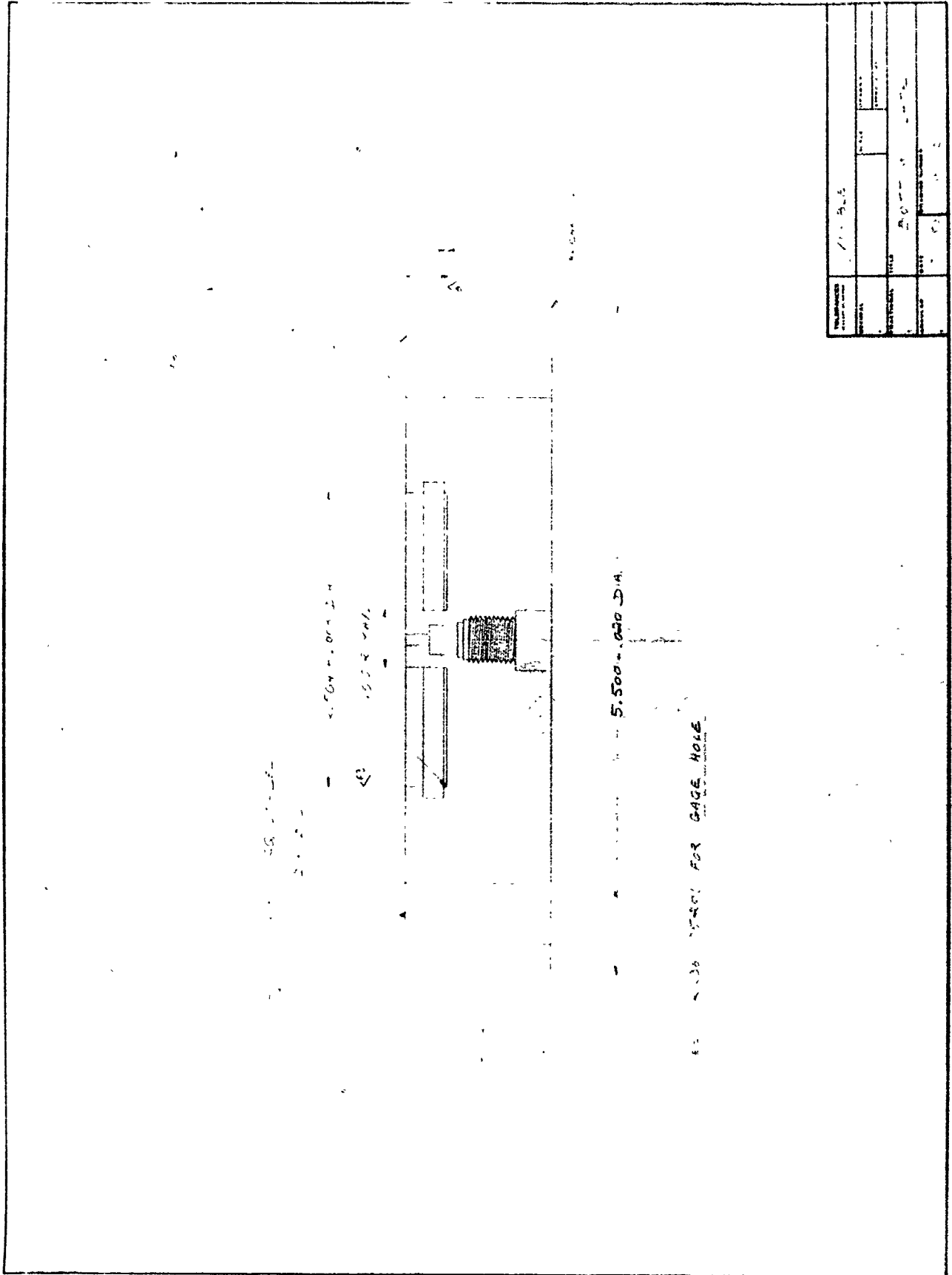

DATE	1/11/2015
BY	
CHECKED	
APPROVED	
REVISIONS	
NO.	DESCRIPTION
1	AS SHOWN

1. ER 11 - STOC. 10 QND.
 1/24 14 544.52 / 14 -

BREY 100 30 110

2.561 - .003 DIA.

5. ER 1010 MIN. (TYR)

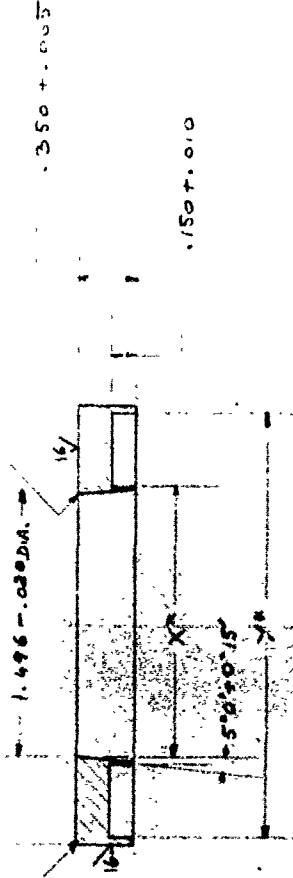

SEE SK 100175110

DRAWING NO. SCALE DATE 1/30/54	DISC 1/30/54	UNITED STATES ARMY BALLISTIC RESEARCH LABORATORIES ABERDEEN PROVING GROUND MARYLAND 21025
VISIBLE CLOSED BOMB		TOP END CAP # 1
PREPARED BY: [blank] CHECKED BY: [blank] APPROVED BY: [blank]		SHEET OF

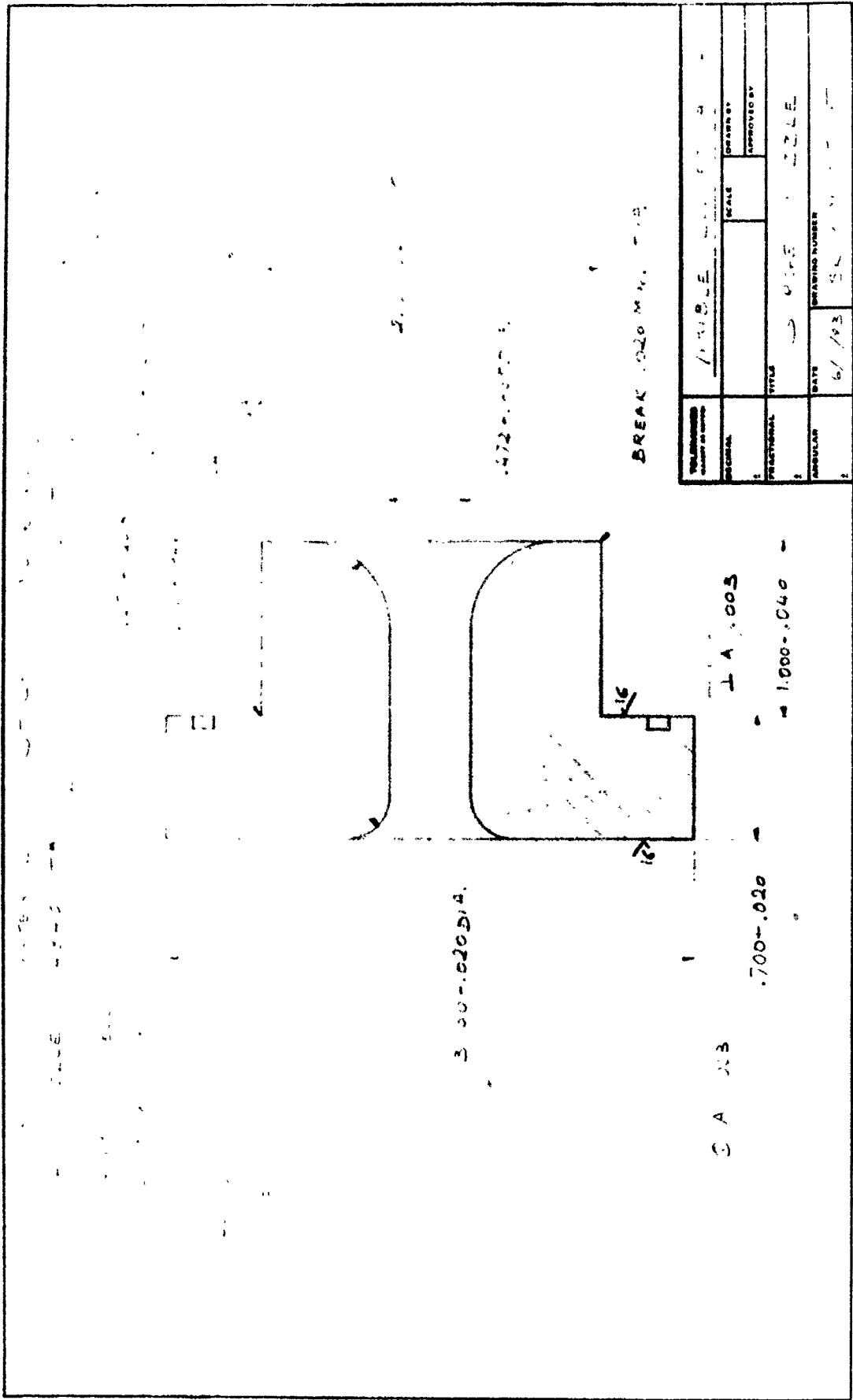

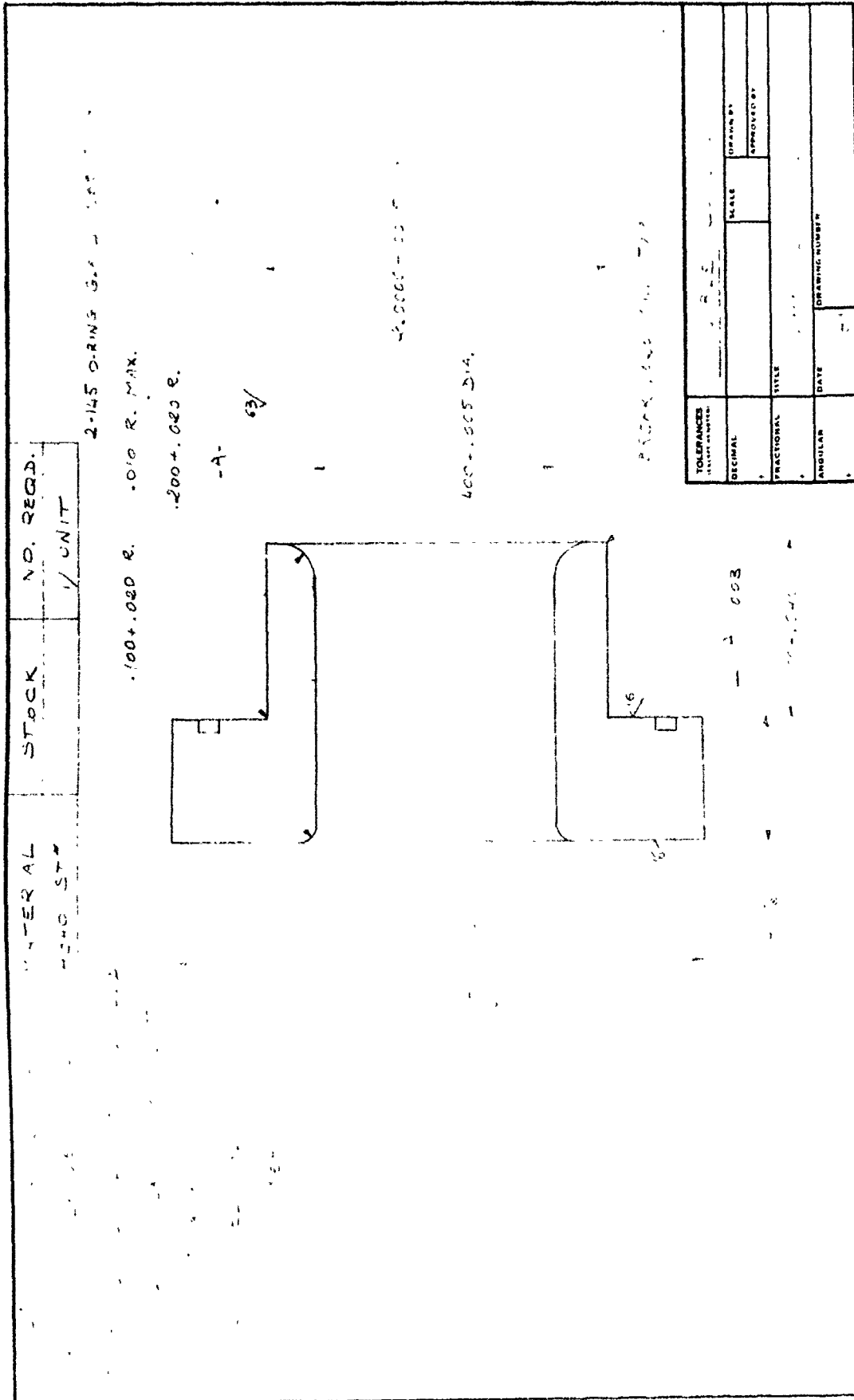

FORM NO.	DATE	BY
SECTION	SCALE	UNIT

1. H.T. 210,000 sq/ft MID FIELD
 2. H.T. 200,000 sq/ft 7th. CRT.
 3. H.T. 40% S.A.
 4. H.T. 40% S.A.
 5. H.T. (REF.)

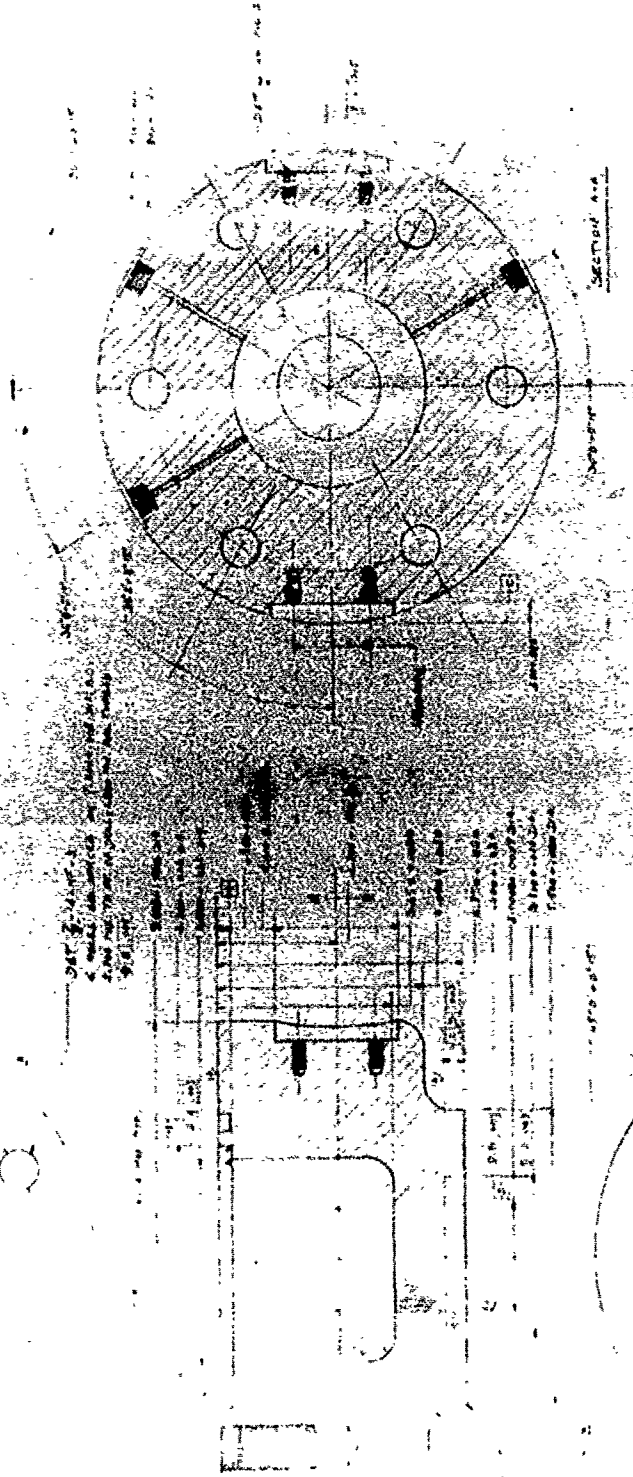

NOTE: SEE SK 180123004
 FOR DETAILS OF TANK HOLES
 MACHINING DETAILS

DATE: 10/10/53
 DRAWN BY: JAMES W. HARRIS
 CHECKED BY: JAMES W. HARRIS
 (SIGNED)

PROJECT	NO. 100000
DATE	10/10/53
BY	JAMES W. HARRIS
CHECKED	JAMES W. HARRIS

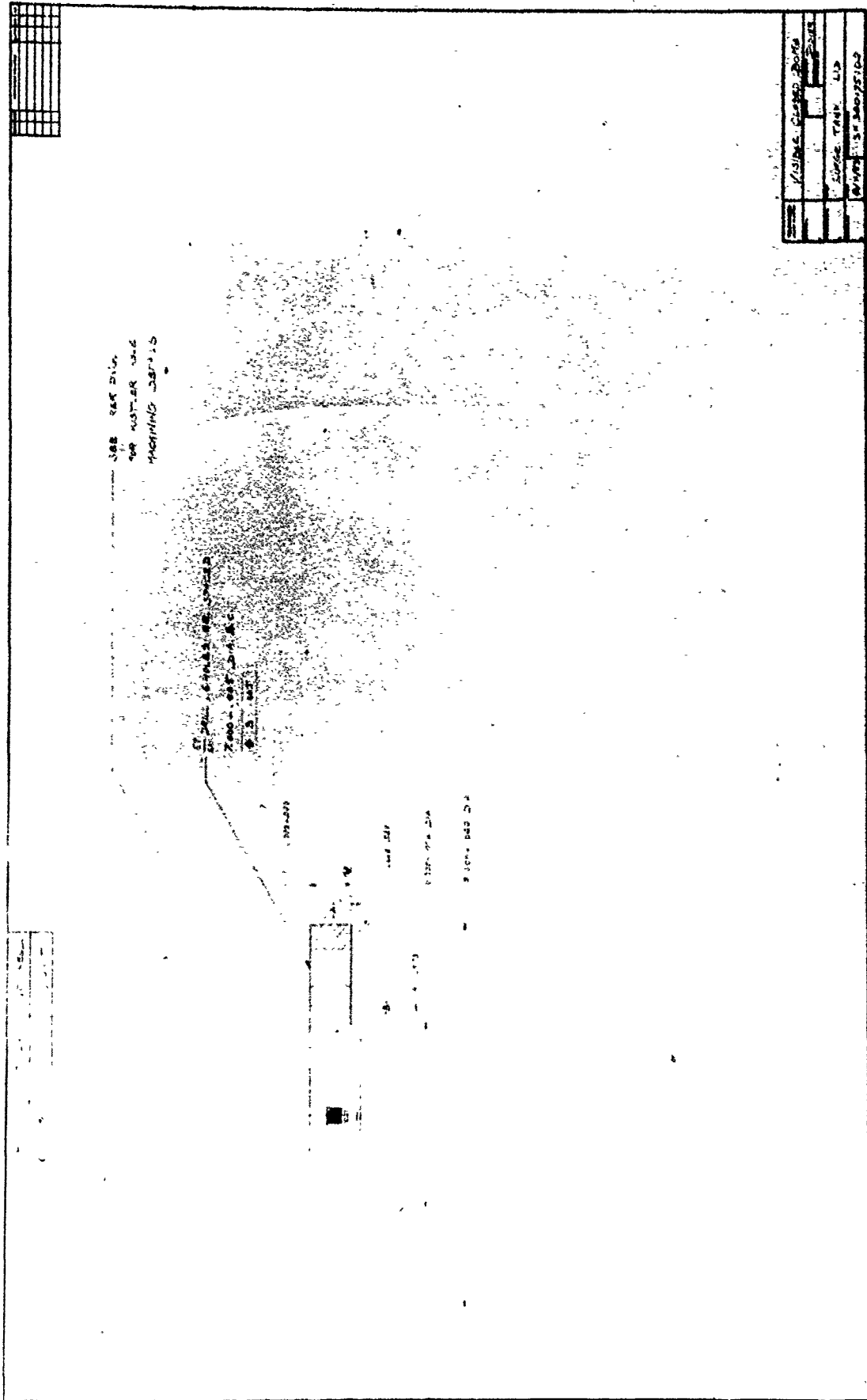



1	3.1.1	3.1.2	3.1.3
2	3.1.4	3.1.5	3.1.6
3	3.1.7	3.1.8	3.1.9
4	3.1.10	3.1.11	3.1.12

DRILLING LOG
 of 1.500-005 D.W. B.C.

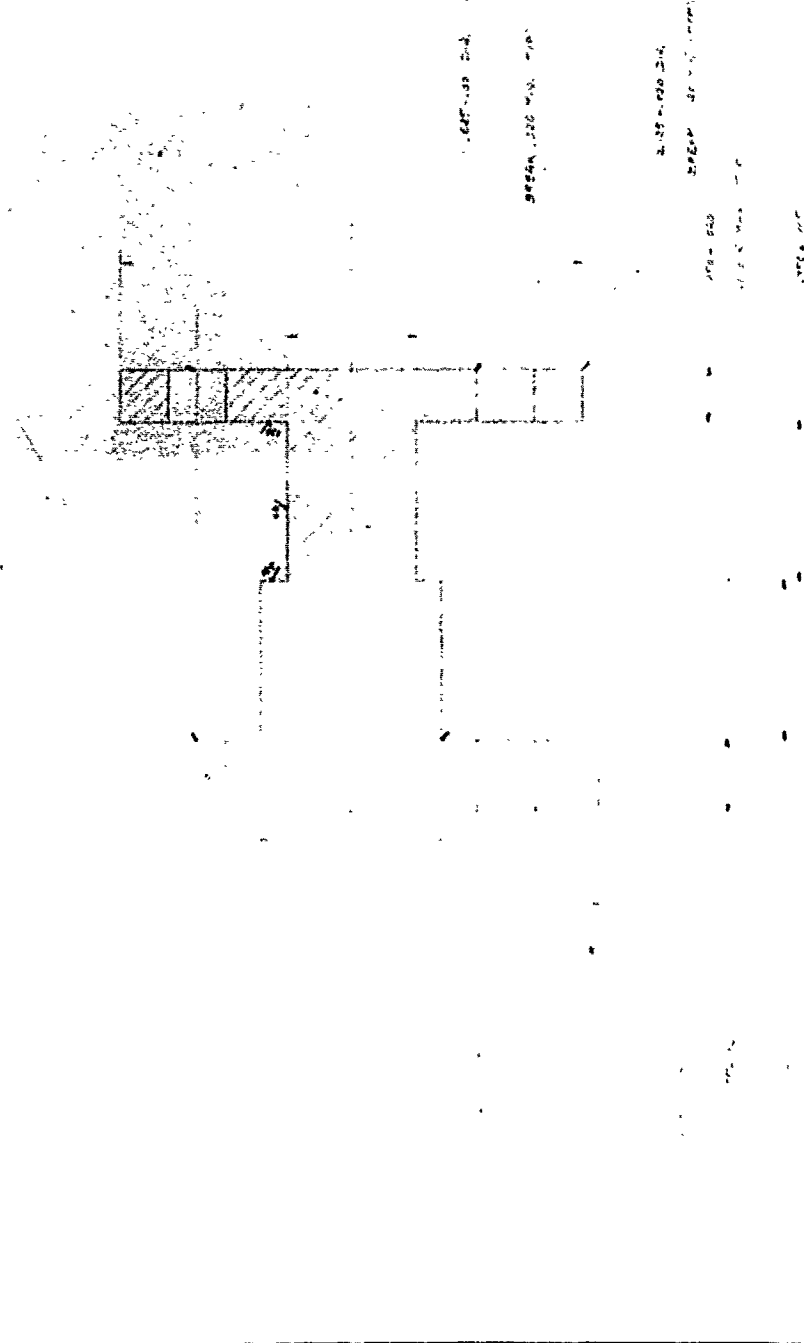

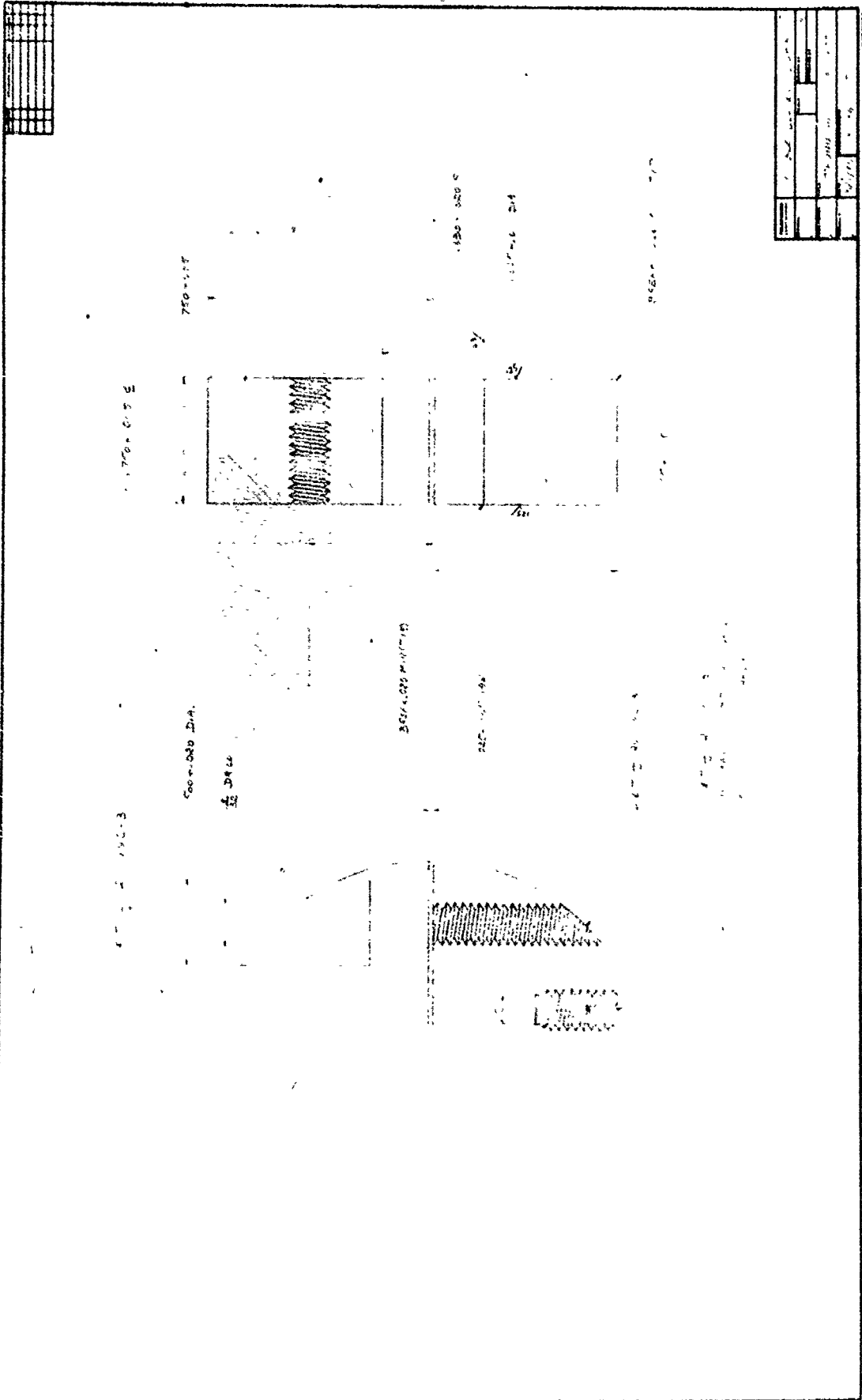

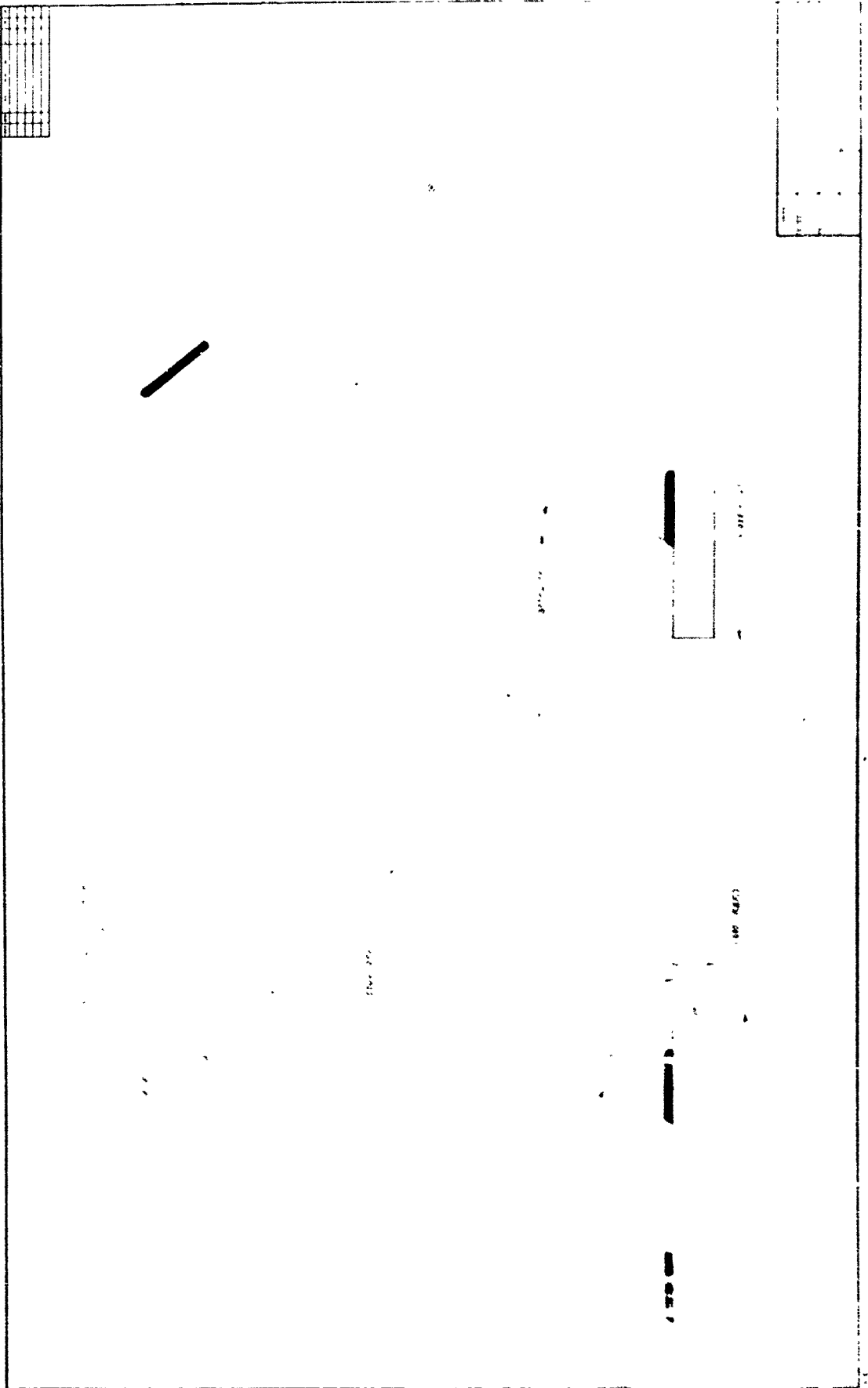

DISTRIBUTION LIST

<u>No. Of Copies</u>	<u>Organization</u>	<u>No. Of Copies</u>	<u>Organization</u>
12	Administrator Defense Technical Info Center ATTN: DTIC-DDA Cameron Station Alexandria, VA 22314	1	Commander US Army Materiel Command ATTN: AMCDRA-ST 5001 Eisenhower Avenue Alexandria, VA 22333
1	Office of the Under Secretary of Defense Research & Engineering ATTN: R. Thorkildsen The Pentagon Washington, DC 20310	1	HQDA DAMA-ART-M Washington, DC 20310
1	HQDA/SAUS-OR, C. Hardison Washington, DC 20310	14	Commander US Army Armament R&D Center ATTN: SMCAR-TSS SMCAR-TDC D. Gyorog SMCAR-LCA J. Lannon A. Beardell D. Downs S. Einstein L. Schlosberg S. Westley S. Bernstein P. Kemmey C. Heyman A. Bracuti Dover, NJ 07801
1	HQDA/DAMA-ZA Washington, DC 20310		
1	HQDA, DAMA-CSM, E. Lippi Washington, DC 20310		
1	HQDA/SARDA Washington, DC 20310		
1	Commander US Army War College ATTN: Library-FF229 Carlisle Barracks, PA 17013		
	Director	9	Commander US Army Armament R&D Center ATTN: SMCAR-SCA, L. Stiefel B. Brodman SMCAR-LCB-I, D. Spring SMCAR-LCE, R. Walker SMCAR-LCU-CT, E. Barrieres R. Davitt SMCAR-LCU-CV C. Mandala W. Joseph SMCAR-ICM-E, S. Kaplowitz Dover, NJ 07801
1	US Army Ballistic Missile Defense Advanced Technology Center P. O. Box 1500 Huntsville, AL 35807		
1	Chairman DOD Explosives Safety Board Room 856-C Hoffman Bldg. 1 2461 Eisenhower Avenue Alexandria, VA 22331		
1	Commander US Army Development & Employment Agency ATTN: NODE-TED-SAB Fort Lewis, WA 98433	1	Commander US Army Materiel Command ATTN: AMRSF-E, Safety Office 5001 Eisenhower Avenue Alexandria, VA 22333
1	Commander US Army Materiel Command ATTN: AMCEP 5001 Eisenhower Avenue Alexandria, VA 22333	1	Commander US Army Missile Command ATTN: AMSTA-YDL Redstone Arsenal, AL 35898

45

DISTRIBUTION LIST

<u>No. Of Copies</u>	<u>Organization</u>	<u>No. Of Copies</u>	<u>Organization</u>
1	Commander US Army Armament R&D Center ATTN: SMCAR-QAR, J. Rutkowski Dover, NJ 07801	5	Commander US Army Armament Munitions and Chemical Command ATTN: AMSMC -LEP-L, Tech Lib AMSMC -LC, L. Ambrosini AMSMC -IRC, G. Cowan AMSMC -LEM, W. Fortune R. Zastrow Rock Island, IL 61299
5	Project Manager Cannon Artillery Weapons System ATTN: AMCPM -CW, F. Menke AMCPM-CWW H. Noble AMCPM-CWS M. Fissette AMCPM-CWA, R. DeKleine H. Hassmann Dover, NJ 07801	1	Commander US Army AMCCOM Benet Weapons Laboratory ATTN: SMCAR -RD, R. Thierry Watervliet, NY 12189
2	Project Manager Munitions Production Base Modernization and Expansion ATTN: AMCPM- PMB, A. Siklosi SARPM-PBM-E, L. Laibson Dover, NJ 07801	1	Director US Army AMCCOM Benet Weapons Laboratory ATTN: SMCAR -LCB-TL Watervliet, NY 12189
3	Project Manager Tank Main Armament System ATTN: AMCPM-TMA, K. Russell AMCPM-TMA-105 AMCPM-TMA-120 Dover, NJ 07801	1	Commander US Army Aviation Research and Development Command ATTN: AMSAV-E 4300 Goodfellow Blvd. St. Louis, MO 63120
3	Commander US Army Armament R&D Center ATTN: SMCAR-LCW-A M.Salsbury SMCAR-LCS SMCAR-LC, J. Frasier Dover, NJ 07801	1	Commander US Army TSARCOM 4300 Goodfellow Blvd. St. Louis, MO 63120
		1	Director US Army Air Mobility Research And Development Laboratory Ames Research Center Moffett Field, CA 94035
		1	Commander US Army Communications Research and Development Command ATTN: AMSEL -ATDD Fort Monmouth, NJ 07703

DISTRIBUTION LIST

<u>No. Of Copies</u>	<u>Organization</u>	<u>No. Of Copies</u>	<u>Organization</u>
1	Commander US Army Electronics Research and Development Command Technical Support Activity ATTN: AMDSD-L Fort Monmouth, NJ 07703	1	Project Manager Fighting Vehicle Systems ATTN: AMSTA-FVS US Army Tank Automotive Command Warren, MI 48090
1	Commander US Army Harry Diamond Lab. ATTN: AMXDO-TI 2800 Powder Mill Road Adelphi, MD 20783	1	Director US Army TRADOC Systems Analysis Activity ATTN: ATAA-SL White Sands Missile Range, NM 88002
1	Commander US Army Missile Command ATTN: AMSTA-R Redstone Arsenal, AL 35890	1	Project Manager M-60 Tank Development ATTN: AMSTA-M60TD US Army Tank Automotive Command Warren, MI 48090
1	Commander US Army Natick Research and Development Command ATTN: AMXRD, D. Sieling Natick, MA 01760	1	Commander US Army Training & Doctrine Command ATTN: ATCD-MA/ MAJ Williams Fort Monroe, VA 23651
1	Commander US Army Tank Automotive Command ATTN: AMSTA-TSL Warren, MI 48090	2	Commander US Army Materials and Mechanics Research Center ATTN: AMXMR-ATL Tech Library Watertown, MA 02172
1	Commander US Army Tank Automotive Command ATTN: AMSTA-CG Warren, MI 48090	1	Commander US Army Research Office ATTN: Tech Library P. O. Box 12211 Research Triangle Park, NC 27709
1	Project Manager Improved TOW Vehicle ATTN: AMSTA-ITV US Army Tank Automotive Command Warren, MI 48090	1	Commander US Army Mobility Equipment Research & Development Command ATTN: AMDME-WC Fort Belvoir, VA 22060
2	Program Manager M1 Tank System US Army Tank Automotive Command ATTN: AMSTA-GCM-SA, J. Roossien Warren, MI 48090	1	Commander US Army Logistics Mgmt Ctr Defense Logistics Studies Fort Lee, VA 23801

DISTRIBUTION LIST

<u>No. Of Copies</u>	<u>Organization</u>	<u>No. Of Copies</u>	<u>Organization</u>
2	Commandant US Army Infantry School ATTN: ATSH-CD-CSO-OR Fort Benning, GA 31905	3	Commandant US Army Armor School ATTN: ATZK-CD-MS/ M. Falkovitch Armor Agency Fort Knox, KY 40121
1	US Army Armor & Engineer Board ATTN: STEBB-AD-S Fort Knox, KY 40121	1	Chief of Naval Materiel Department of the Navy ATTN: J. Amlie Washington, DC 20360
1	Commandant US Army Aviation School ATTN: Aviation Agency Fort Rucker, AL 36360	1	Office of Naval Research ATTN: Code 473, R. S. Miller 800 N. Quincy Street Arlington, VA 22217
1	Commandant US Army Command and General Staff College Fort Leavenworth, KS 66027	1	Commander Naval Sea Systems Command ATTN: SEA-62R2, R. Beauregard National Center, Bldg. 2 Room 6E08 Washington, DC 20360
1	Commandant US Army Special Warfare School ATTN: Rev & Tng Lit Div Fort Bragg, NC 28307	1	Commander Naval Air Systems Command ATTN: NAIR-954-Tech Lib Washington, DC 20360
1	Commandant US Army Engineer School Ft. Belvoir, VA 22060	1	Strategic Systems Project Office Dept. of the Navy Room 901 ATTN: J. F. Kincaid Washington, DC 20376
1	Commander US Army Foreign Science & Technology Center ATTN: AMXST -MC-3 220 Seventh Street, NE Charlottesville, VA 22901	1	Assistant Secretary of the Navy (R, E, and S) ATTN: R. Reichenbach Room 5E787 Pentagon Bldg. Washington, DC 20350
1	President US Army Artillery Board Ft. Sill, OK 73503	1	Commander Naval Research Lab Tech Library Washington, D.C. 20375
2	Commandant US Army Field Artillery School ATTN: ATSF-CO-MW, B. Willis Ft. Sill, OK 73503		

DISTRIBUTION LIST

<u>No. Of Copies</u>	<u>Organization</u>	<u>No. Of Copies</u>	<u>Organization</u>
5	Commander Naval Surface Weapons Center ATTN: Code G33, J. L. East W. Burrell J. Johndrow Code G23, D. McClure Code DX-21 Tech Lib Dahlgren, VA 22448	6	Commander Naval Ordnance Station ATTN: P. L. Stang J. Birkett S. Mitchell C. Christensen D. Brooks Tech Library Indian Head, MD 20640
2	Commander US Naval Surface Weapons Center ATTN: J. P. Consaga C. Gotzmer Indian Head, MD 20640	1	AFSC/SDOA Andrews AFB, MD 20334
4	Commander Naval Surface Weapons Center ATTN: S. Jacobs/Code 240 Code 730 K. Kim/Code R-13 R. Bernecker Silver Spring, MD 20910	1	Program Manager AFOSR Directorate of Aerospace Sciences ATTN: L. H. Caveny Bolling AFB, DC 20332
2	Commanding Officer Naval Underwater Systems Center Energy Conversion Dept. ATTN: CODE 5B331, R. S. Lazar Tech Lib Newport, RI 02840	6	AFRPL (DYSC) ATTN: D. George J. N. Levine B. Goshgarian D. Thrasher N. Vander Hyde Tech Library Edwards AFB, CA 93523
4	Commander Naval Weapons Center ATTN: Code 388, R. L. Derr C. F. Price T. Boggs Info. Sci. Div. China Lake, CA 93555	1	AFFTC ATTN: SSD-Tech Lib Edwards AFB, CA 93523
2	Superintendent Naval Postgraduate School Dept. of Mechanical Engineering ATTN: A. E. Fuhs Code 1424 Library Monterey, CA 93940	1	AFATL/DLYV Eglin AFB, FL 32542
		1	AFATL/DLXP ATTN: W. Dittrich Eglin AFB, FL 32542
		1	AFATA/DLD ATTN: D. Davis Eglin AFB, FL 32542
		1	AFATL/DLXL ATTN: O. K. Heiney Eglin AFB, FL 32542

DISTRIBUTION LIST

<u>No. Of Copies</u>	<u>Organization</u>	<u>No. Of Copies</u>	<u>Organization</u>
1	AFATL/DLODL ATTN: Tech Lib Eglin AFB, FL 32542	1	AFWL/SUL Kirtland AFB, NM 87117
1	AFFDL ATTN: TST-Lib Wright-Patterson AFB, OH 45433	1	General Applied Sciences Lab ATTN: J. Erdos Merrick & Stewart Avenues Westbury, NY 11590
1	Lawrence Livermore Laboratory ATTN: M.S. L-355, M. Finger P.O. Box 808 Livermore, CA 94550	1	General Electric Company Armament Systems Dept. ATTN: M. J. Bulman, Room 1311 Lakeside Avenue Burlington, VT 05401
1	NASA/Lyndon B. Johnson Space Center ATTN: NHS-22, Library Section Houston, TX 77058	1	Hercules, Inc. Allegany Ballistics Laboratory ATTN: R. B. Miller P. O. Box 210 Cumberland, MD 21501
1	Aerodyne Research, Inc. Bedford Research Park ATTN: V. Yousefian Bedford, MA 01730	1	Hercules, Inc Bacchus Works ATTN: K. P. McCarty P. O. Box 98 Magna, UT 84044
1	Aerojet Solid Propulsion Co. ATTN: P. Micheli Sacramento, CA 95813	1	Hercules, Inc. Eglin Operations AFATL DLDL ATTN: R. L. Simmons Eglin AFB, FL 32542
1	Atlantic Research Corporation ATTN: M. K. King 5390 Cheorokee Avenue Alexandria, VA 22314	1	IITRI ATTN: M. J. Klein 10 W. 35th Street Chicago, IL 60616
1	AVCO Everett Rsch Lab ATTN: D. Stickler 2385 Revere Beach Parkway Everett, MA 02149	1	Lawrence Livermore Laboratory ATTN: M. S. L-355, A. Buckingham P. O. Box 808 Livermore, CA 94550
2	Calspan Corporation ATTN: Tech Library P. O. Box 400 Buffalo, NY 14225		
1	Foster Miller Associates ATTN: A. Erickson 135 Second Avenue Waltham, MA 02154		

DISTRIBUTION LIST

<u>No. Of Copies</u>	<u>Organization</u>	<u>No. Of Copies</u>	<u>Organization</u>
1	Olin Corporation Badger Army Ammunition Plant ATTN: R. J. Thiede Baraboc, WI 53913	1	Scientific Research Assoc., Inc. ATTN: H. McDonald P.O. Box 498 Glastonbury, CT 06033
1	Olin Corporation Smokeless Powder Operations ATTN: R. L. Cook P. O. Box 222 St. Marks, FL 32355	3	Thiokol Corporation Huntsville Division ATTN: D. Flanigan R. Glick Tech Library Huntsville, AL 35807
1	Paul Gough Associates, Inc. ATTN: P. S. Gough P. O. Box 1614 Portsmouth, NH 03801	2	Thiokol Corporation Wasatch Division ATTN: J. Peterson Tech Library P. O. Box 524 Brigham City, UT 84302
1	Physics International Company 2700 Merced Street San Leandro, CA 94577	2	Thiokol Corporation Elkton Division ATTN: R. Biddle Tech Lib. P. O. Box 241 Elkton, MD 21921
1	Princeton Combustion Research Lab., Inc. 475 US Highway One Monmouth Junction, NJ 08854	2	United Technologies Chemical Systems Division ATTN: R. Brown Tech Library P. O. Box 358 Sunnyvale, CA 94086
1	Pulsepower Systems, Inc. ATTN: L. C. Elmore 815 American Street San Carlos, CA 94070	1	Universal Propulsion Company ATTN: H. J. McSpadden Black Canyon Stage 1 Box 1140 Phoenix, AZ 85029
2	Rockwell International Rocketdyne Division ATTN: BA08 J. E. Flanagan J. Gray 6633 Canoga Avenue Canoga Park, CA 91304	1	Veritay Technology, Inc. ATTN: E. B. Fisher Propulsion Department 4845 Millersport Highway P. O. Box 305 East Amherst, NY 14051
1	Science Applications, Inc. ATTN: R. B. Edelman 23146 Cumorah Crest Woodland Hills, CA 91364		

DISTRIBUTION LIST

<u>No. Of Copies</u>	<u>Organization</u>	<u>No. of Copies</u>	<u>Organization</u>
1	Southwest Research Institute Institute Scientists 8500 Culebra Road San Antonio, TX 78228	1	Case Western Reserve University Division of Aerospace Sciences ATTN: J. Tien Cleveland, OH 44135
1	Battelle Memorial Institute ATTN: Tech Library 505 King Avenue Columbus, OH 43201	3	Georgia Institute of Tech School of Aerospace Eng. ATTN: B. T. Zinn E. Price W. C. Strahle Atlanta, GA 30332
1	Brigham Young University Dept. of Chemical Engineering ATTN: M. Beckstead Provo, UT 84601	1	Institute of Gas Technology ATTN: D. Gidaspo 3424 S. State Street Chicago, IL 60616
1	California Institute of Tech 204 Karman Lab Main Stop 301-46 ATTN: F. E. C. Culick 1201 E. California Street Pasadena, CA 91125	1	Johns Hopkins University Applied Physics Laboratory Chemical Propulsion Information Agency ATTN: T. Christian Johns Hopkins Road Laurel, MD 20707
1	Director Jet Propulsion Laboratory ATTN: L. D. Strand 4800 Oak Grove Drive Pasadena, CA 91109	1	Massachusetts Institute of Technology Dept of Mechanical Engineering ATTN: T. Toong Cambridge, MA 02139
1	University of Illinois AAE Department ATTN: H. Krier Transportation Bldg. Rm 105 Urbana, IL 61801	1	Pennsylvania State University Applied Research Lab ATTN: G. M. Faeth P. O. Box 30 State College, PA 16801
1	University of Massachusetts Dept. of Mechanical Engineering ATTN: K. Jakus Amherst, MA 01002	1	Pennsylvania State University Dept. Of Mechanical Engineering ATTN: K. Kuo University Park, PA 16802
1	University of Minnesota Dept. of Mechanical Engineering ATTN: E. Fletcher Minneapolis, MN 55455		

DISTRIBUTION LIST

<u>No. Of</u> <u>Copies</u>	<u>Organization</u>	<u>No. Of</u> <u>Copies</u>	<u>Organization</u>
1	Purdue University School of Mechanical Engineering ATTN: J. R. Osborn TSPC Chaffee Hall West Lafayette, IN 47906	1	Washington State University Dept. of Mechanical Engineering ATTN: C. T. Crowe Pullman, WA 99163
1	Rensselaer Polytechnic Inst. Department of Mathematics Troy, NY 12181		<u>Aberdeen Proving Ground</u>
1	Rutgers University Dept. of Mechanical and Aerospace Engineering ATTN: S. Temkin University Heights Campus New Brunswick, NJ 08903		Dir, USAMSAA ATTN: AMXSY -D AMXSY -MP, H. Cohen Cdr, USATECOM ATTN: AMSTE -TO-F STECS-AA-W, S. Walton G. Rice D. Lacey C. Herud
1	SRI International Propulsion Sciences Division ATTN: Tech Library 333 Ravenswood Avenue Menlo Park, CA 94025		Dir, HEL ATTN: J. Weisz Cdr, CRDC, AMCCOM ATTN: SMCCR-RSP-A SMCCR-MU SMCCR-SPS-IL
1	Stevens Institute of Technology Davidson Laboratory ATTN: R. McAlevy, III Hoboken, NJ 07030		
2	Director Los Alamos Scientific Lab ATTN: T3, D. Butler M. Division, B. Craig P. O. Box 1663 Los Alamos, NM 87544		
1	University of Southern California Mechanical Engineering Dept. ATTN: OHE200, M. Gerstein Los Angeles, CA 90007		
2	University of Utah Dept. of Chemical Engineering ATTN: A. Baer G. Flandro Salt Lake City, UT 84112		