

MICROCOPY RESOLUTION TEST CHART
NATIONAL BUREAU OF STANDARDS-1963-A

12

USAARL REPORT NO. 84-12



THE EFFECT OF MODIFIED SPECTACLES ON THE FIELD OF VIEW OF THE HELMET DISPLAY UNIT OF THE INTEGRATED HELMET AND DISPLAY SIGHTING SYSTEM

AD-A148 693

By
William E. McLean
Clarence E. Rash

SENSORY RESEARCH DIVISION

September 1984

DEC 27 1984
A

DTIC FILE COPY

U.S. ARMY AEROMEDICAL RESEARCH LABORATORY
FORT RUCKER, ALABAMA 36362

USAARL

84 12 17 005

NOTICE

Qualified Requesters

Qualified requesters may obtain copies from the Defense Technical Information Center, Cameron Station, Alexandria, Virginia, 22314. Orders will be expedited if placed through the librarian or other person designated to request documents from the Defense Technical Information Center.

Change of Address

Organizations receiving reports from the US Army Aeromedical Research Laboratory on automatic mailing lists should confirm correct address when corresponding about laboratory reports.

Disposition

Destroy this report when it is no longer needed. Do not return it to the originator.

Disclaimer

The views, opinions, and/or findings contained in this report are those of the authors and should not be construed as an official Department of the Army position, policy, or decision, unless so designated by other official documentation. Citation of trade names in this report does not constitute an official Department of the Army endorsement or approval of the use of such commercial items.

Human Use

Human subjects participated in these studies after giving free and informed voluntary consent. Investigators adhered to AR 70-25 and USAMRDC Reg 70-25 on Use of Volunteers in Research.

Reviewed:

BRUCE C. LEIBRECHT, Ph.D.
MAJ, MS
Director, Sensory Research Division

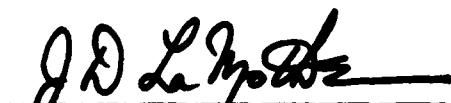
J. D. LaMOTHE, Ph.D.
LTC(P), MS
Chairman, Scientific Review
Committee

Released for Publication:

DUDLEY R. PRICE
Colonel, MC, SFS
Commanding

UNCLASSIFIED

SECURITY CLASSIFICATION OF THIS PAGE (When Data Entered)

REPORT DOCUMENTATION PAGE		READ INSTRUCTIONS BEFORE COMPLETING FORM
1. REPORT NUMBER USAARL Report No. 84-12	2. GOVT ACCESSION NO. AD-A149693	3. RECIPIENT'S CATALOG NUMBER
4. TITLE (and Subtitle) The Effect of Modified Spectacles on the Field-of-View of the Helmet Display Unit of the Integrated Helmet and Display Sighting System	5. TYPE OF REPORT & PERIOD COVERED	
	6. PERFORMING ORG. REPORT NUMBER	
7. AUTHOR(s) William E. McLean and Clarence E. Rash	8. CONTRACT OR GRANT NUMBER(s)	
9. PERFORMING ORGANIZATION NAME AND ADDRESS US Army Aeromedical Research Laboratory Fort Rucker, AL 36362	10. PROGRAM ELEMENT, PROJECT, TASK AREA & WORK UNIT NUMBERS 62777.A.3E162777A879,164	
11. CONTROLLING OFFICE NAME AND ADDRESS	12. REPORT DATE September 1984	
	13. NUMBER OF PAGES 30	
14. MONITORING AGENCY NAME & ADDRESS (if different from Controlling Office) US Army Medical Research and Development Command Fort Detrick Frederick, MD 21701	15. SECURITY CLASS. (of this report) UNCLASSIFIED	
	15a. DECLASSIFICATION/DOWNGRADING SCHEDULE	
16. DISTRIBUTION STATEMENT (of this Report) Distribution unlimited.		
17. DISTRIBUTION STATEMENT (of the abstract entered in Block 20, if different from Report)		
18. SUPPLEMENTARY NOTES		
19. KEY WORDS (Continue on reverse side if necessary and identify by block number) modified spectacles field-of-view helmet display unit (HDU) Integrated Helmet and Display Sighting System (IHADSS) (H DU)		
20. ABSTRACT (Continue on reverse side if necessary and identify by block number) → A study was conducted to establish the effect of wearing modified aviator spectacles, either for laser protection or refractive error correction, on the field-of-view available with the Helmet Display Unit of the Integrated Helmet and Display Sighting System. The determining factors of the available field were found to be helmet fit, eye fixation direction, and eye relief distance. The study concluded that when these factors are optimized, the wearing of the modified spectacles does not result in a loss of field-of-view. ↗		

(IHADSS)

TABLE OF CONTENTS

	Page No.
List of Illustrations	2
Introduction.	4
Methodology	
Subjects.	6
Instrumentation	6
Procedure	7
Results and Discussion.	9
Conclusions and Recommendations	22
Appendix A. List of Equipment Manufacturers.	24

LIST OF ILLUSTRATIONS

Figure		Page No.
1	The Integrated Helmet Unit	4
2	The Modified Spectacles.	5
3	The Meridians Along which the Fields Were Measured	7
4	Estimation of "Eye Relief" Distance.	9
5	The Measured Fields for Subject #1.	10
6	The Measured Fields for Subject #2.	11
7	The Measured Fields for Subject #3.	11
8	The Measured Fields for Subject #4.	12
9	The Measured Fields for Subject #5.	12
10	The Measured Fields for Subject #6.	13
11	The Measured Fields for Subject #7.	13
12	The Measured Fields for Subject #8.	14
13	The Measured Fields for Subject #9.	14
14	The Measured Fields for Subject #10.	15
15	The Measured Fields for Subject #11.	15
16	The Effects of Eye Relief and Fixation Point on Available Field-of-View.	21
17	Theoretical Loss of Available Field.	21

LIST OF TABLES

Table		Page No.
1	Colinear Meridional Fields for Conditions With and Without Spectacles (in Degrees)	17
2	Colinear Meridional Losses or Gains (in Degrees).	18
3	Percent Unavailable Field	22



See Form
 W&I
 Standard
 Application

 Specialty Cases
 Call and/or
 Special

AI

INTRODUCTION

The Integrated Helmet and Display Sighting System (IHADSS) used in the Advanced Attack Helicopter (AAH) is a helmet-mounted display system (Figure 1). Video imagery provided by the Pilot Night Vision System (PNVS) is presented to the pilot on a 1-inch cathode-ray-tube (CRT) which is fitted into an optical relay tube, called the Helmet Display Unit (HDU), attached to the helmet. The CRT imagery is relayed through the HDU and finally reflected off of a beamsplitter, called the combiner. The imagery presented is designed to provide a 40-degree horizontal by 30-degree vertical field.

The positioning of the exit pupil is extremely critical to the ability of the pilot to obtain the full field-of-view. Other factors which affect the field-of-view are: eye relief distance, diopter setting on the HDU (Range: +2 to -6 diopters), and eye fixation point. The eye relief is a function of anatomical facial features, helmet size and fit, combiner extension, and HDU adjustment.

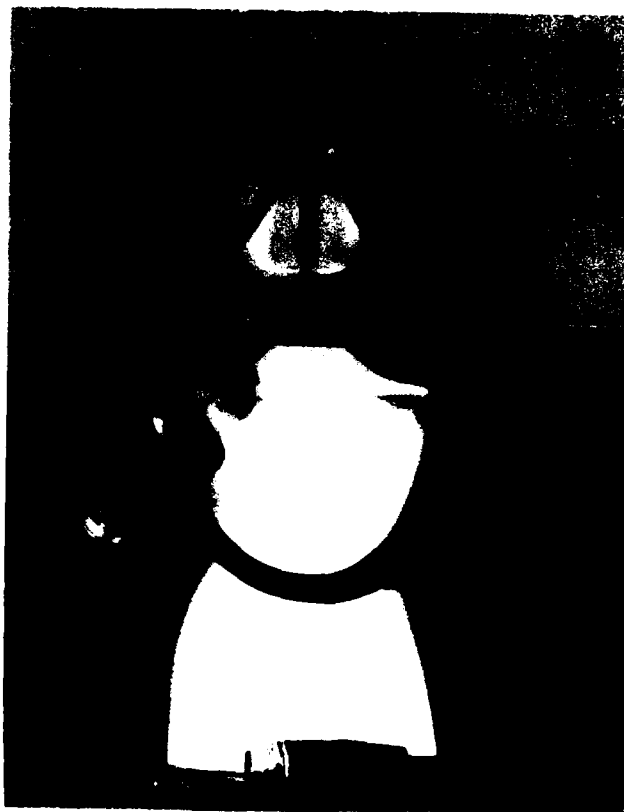

FIGURE 1. The Integrated Helmet Unit.

The HDU, being mounted to the side of the helmet, has an extremely short eye relief. Any device which is required to be worn between the eye and the HDU has the potential of reducing the available field-of-view. Spectacles providing correction of refractive error or protection from laser energy are an example of such a device. Any reduction in the available field-of-view will decrease the effectiveness of the IHADSS.

During the AAH Flight Trainer Infrared Piloting System assessment program, two of three spectacle wearers complained of field loss when wearing specially modified laser protection spectacles, unless the right lens (on the HDU side) was removed. A field loss also was noted by this laboratory during preliminary consultations on the AH-64 chemical and biological (CB) protective masks. No satisfactory method was previously known to quantify the amount of field loss when the utilization of these devices with the HDU was required.

The U.S. Army Aeromedical Research Laboratory (USAARL) has been consulting on the spectacle compatibility problem for several years and has provided several versions of modified aviator's spectacles for use with the IHADSS. Figure 2 shows



FIGURE 2. The modified spectacles.

the current version of these spectacles. Formed from the standard aviator's frames and using KG-3 glass, these spectacles are used to provide ocular protection from the AAH rangefinder/designator laser. USAARL also has provided several pairs of spectacles with prescription plastic lenses to pilots in the PNVS program.

Because of the laboratory's role in developing IHADSS compatible spectacles and the noted problems of field loss, USAARL decided to conduct a study to determine if the available field-of-view with the IHADSS was affected significantly when the wearing of spectacles was required either for the purpose of refractive error correction or laser protection.

METHODOLOGY

Subjects

Eleven subjects were evaluated. Seven of the subjects were either candidate instructor pilots for the AH-64 program or PNVS qualified pilots. Two USAARL research pilots and one research investigator familiar with the IHADSS also were evaluated; the last subject was a trained observer. Identification numbers (#1-11) were assigned for tracking individual subject data.

Five of the subjects (#1, 3, 5, 6, and 11) wear corrective lenses. For the study, four of these individuals were fitted with spectacles with a corrective lens in the right eye which was within 0.25 diopters of each subject's prescription. Subject #11 was fitted with a plano lens because he was not required to wear corrective lenses during his PNVS training. All of the remaining subjects also were fitted with plano lenses.

Instrumentation

The video signals required for initial alignment and for the field-of-view stimuli were generated by a Hewlett-Packard 9845B computer* used in conjunction with a Tektronix 4025 terminal*. The video signals were input to a IHADSS Digital Electronic Unit (DEU) which in turn produced the desired visual output on the CRT display mounted on the helmet. This output was relayed optically through the HDU and reflected off of the combiner. The raster was generated so as to provide a 50-degree

*See Appendix A.

horizontal by 43-degree vertical field. This field size is larger than that actually realized with the fielded display because the fielded version of the CRT is masked, resulting in a field size of 40 degrees, horizontally, and 30 degrees, vertically.

Procedure

Each subject was read an orientation description of the experimental procedure. Then he was fitted with either a medium or large sized IHADSS helmet. The helmets were production versions currently being evaluated at USAARL. Several PNVS pilots provided their own helmets. An alignment pattern was presented to assist the subject in acquiring a centered field-of-view. This pattern consisted of eight meridional lines with numbered tic marks, allowing the subject to insure that a balanced field-of-view was available.

The target stimulus consisted of a small, high contrast, computer generated tic mark which entered the subject's visual field along one of eight different meridians, and progressed in intervals of approximately 1/6 of a degree per second towards a center fixation point. The selected meridians were at the following angles: 0, 36, 90, 144, 180, 216, 270, and 324 degrees. Figure 3 shows the relative directions of the measured meridians. A center fixation cross and a short meridional

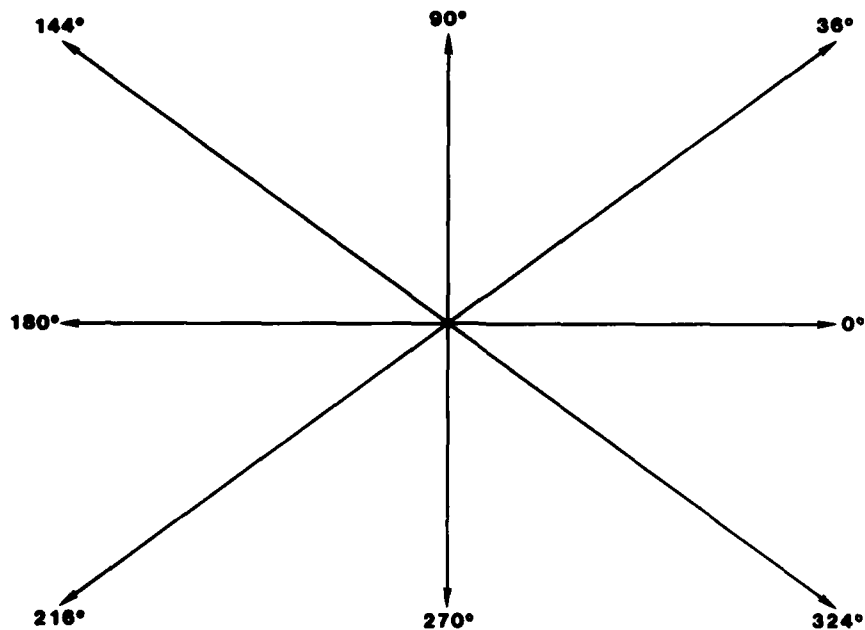

FIGURE 3. The meridians along which the fields were measured.

indicator line were generated for each target. The purpose of the indicator line was to alert the subject to the entry direction of the target. The test consisted of four presentations along each meridian for each condition for each subject, first in a counterclockwise direction and then reversing direction for each successive presentation. The subject was directed to press a designated button upon each detection of the target. An audible beep was generated to provide positive feedback for each detection.

Following orientation, fitting, and alignment, the subject was allowed to make a trial run. During this trial, the subject was instructed to vary his fixation point to verify that the maximum detection field was obtained by fixating on the center cross and not by looking in the direction of the target. The subjects were directed to fixate on the center cross during the actual study.

Once the subject was trained in the data collection procedure, actual data collection was initiated. The testing order for the two conditions, with spectacles and without spectacles, was alternated between subjects in order to counterbalance any learning effects. Also, in order to remove the effects of background distractions, the tests were conducted in a darkened room with the subject viewing the display imagery against a black cloth.

For each condition the subject was directed to realign the HDU and combiner using the alignment pattern, insuring that the available field was maximized for that condition. Following the fitting and alignment for each condition, an estimate of the "eye relief" distance was made by measuring the distance from a point on the HDU at the objective lens to a prescribed point on the combiner and then to the approximate position of the subject's cornea (see Figure 4). This distance, measured in millimeters, was recorded for possible correlation with field loss.

Two support investigations also were conducted. First, the effect of choice of fixation point on the maximum available field was determined by using a single subject and measuring the detection fields when a center fixation point was used and when the subject always looked in the expected direction of the target. Second, to confirm the predicted influence of "eye relief" on the available field, a single subject's fields were measured for minimum and maximum extension of the HDU and combiner. This extension is controlled by adjusting the position of the HDU mount with respect to the mounting bracket attached to the helmet, and by moving the combiner lens on the HDU.

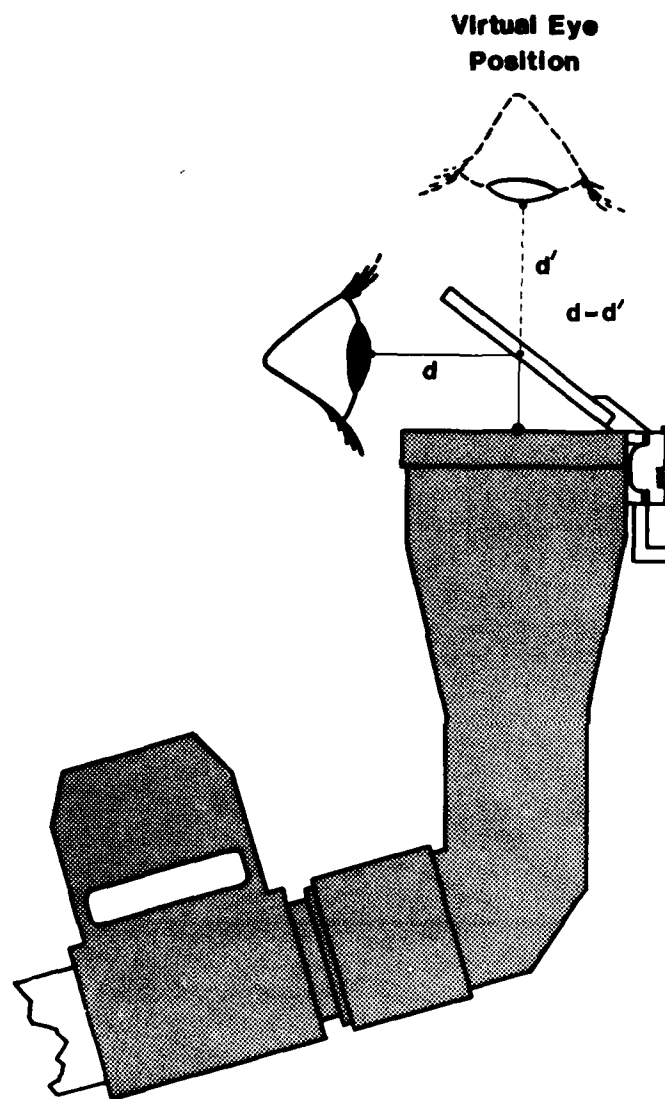

FIGURE 4. Estimation of "eye relief" distance.

RESULTS AND DISCUSSION

Individual field plots for each subject are presented in Figures 5-15. The two outer curves in each plot represent the collected data. The dotted curve represents the field for the condition without spectacles and the solid curve represents the field for the condition with spectacles. The inner, bold rectangle represents the theoretical 30-by 40-degrees field-of-view of the fielded PNVS. Only subjects #9 and #11

graphically show a significant difference in the fields for the two conditions. Subject #9 (Figure 13) shows a small field loss in the first and third quadrants and considerable loss in the fourth quadrant. However, subject #11 (Figure 15) shows a field gain in all quadrants. Based on the overall results for all subjects, the fields for these two subjects most likely can be attributed to more care being taken in the fitting of the HDU for one condition over the other than to actual differences in the fields. One other reason for the large gain for subject #11 is that this subject normally wore corrective lenses and may have deliberately or subconsciously skewed the results to insure that no field loss was measured. If this study had shown that significant field losses result from the wearing of spectacles, then this subject could be restricted in future AH-64 assignments.

A very critical factor which will affect the field size along any given meridian is the alignment of the HDU. For example, misalignment along the horizontal image axis could result in a measured field increase along the 0 degree meridian, but with a decrease along the colinear 180 degree meridian. In an attempt to minimize this effect, the data analysis was performed on pairs of colinear meridians, i.e., 0 and 180, 36

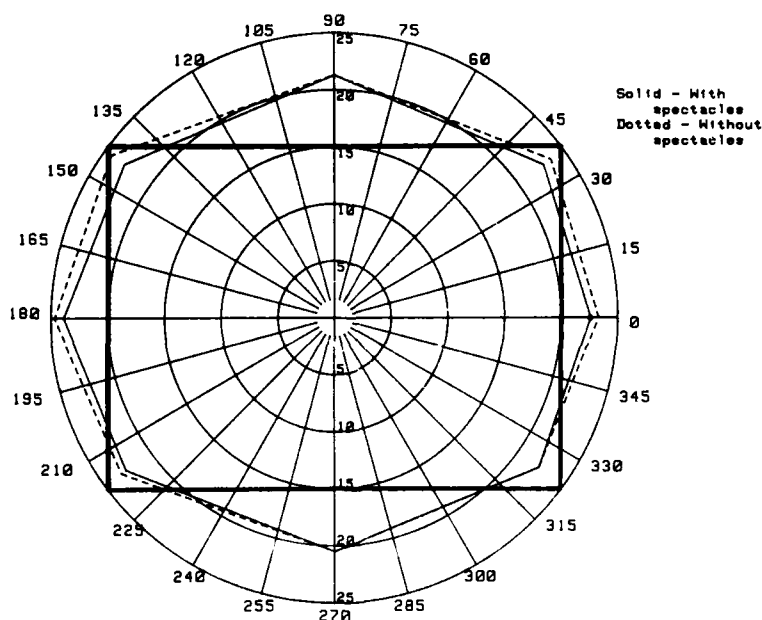

FIGURE 5. The measured fields for subject #1.

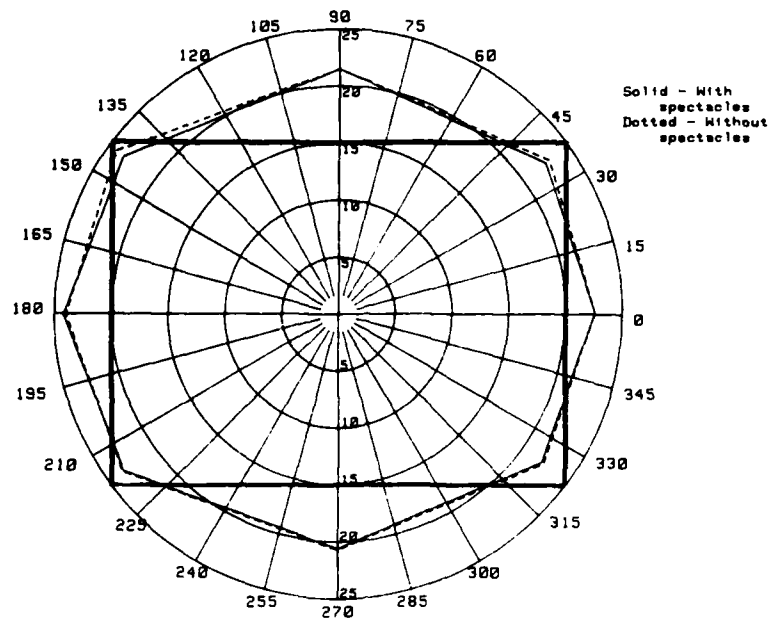

FIGURE 6. The measured fields for subject #2.

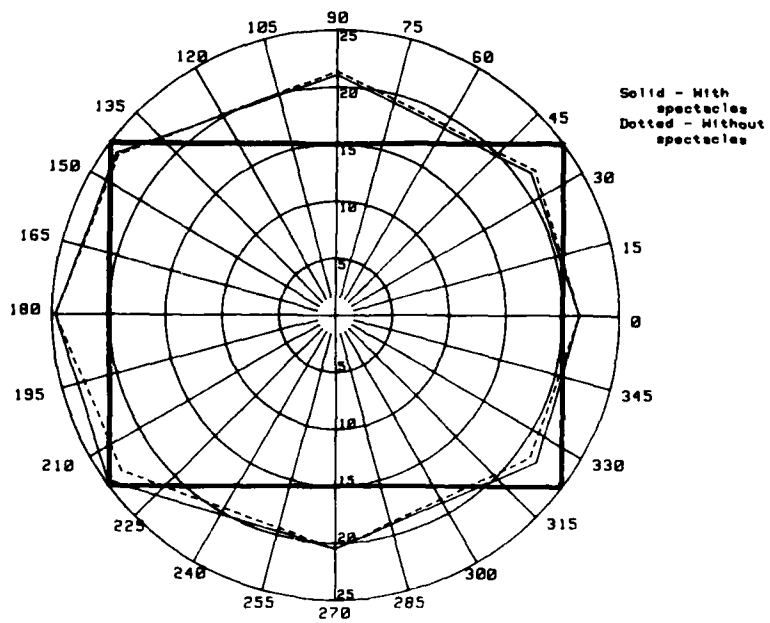

FIGURE 7. The measured fields for subject #3.

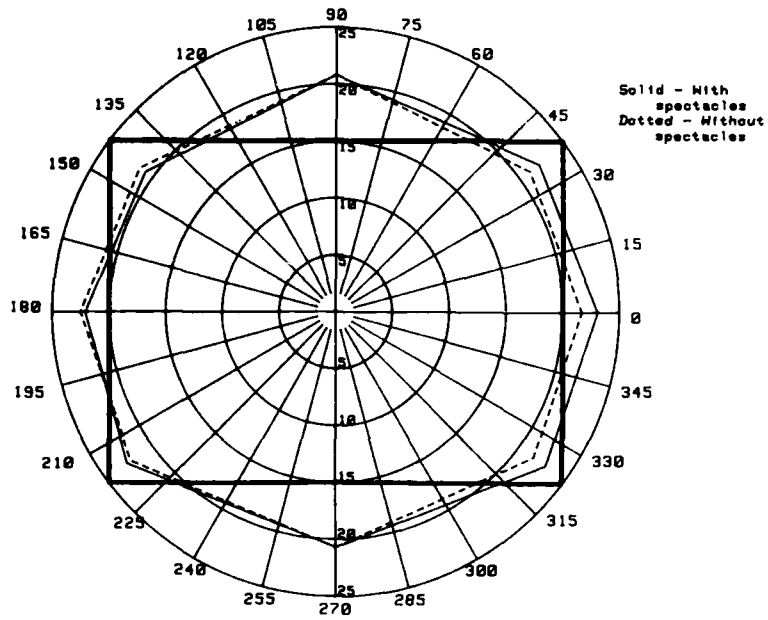

FIGURE 8. The measured fields for subject #4.

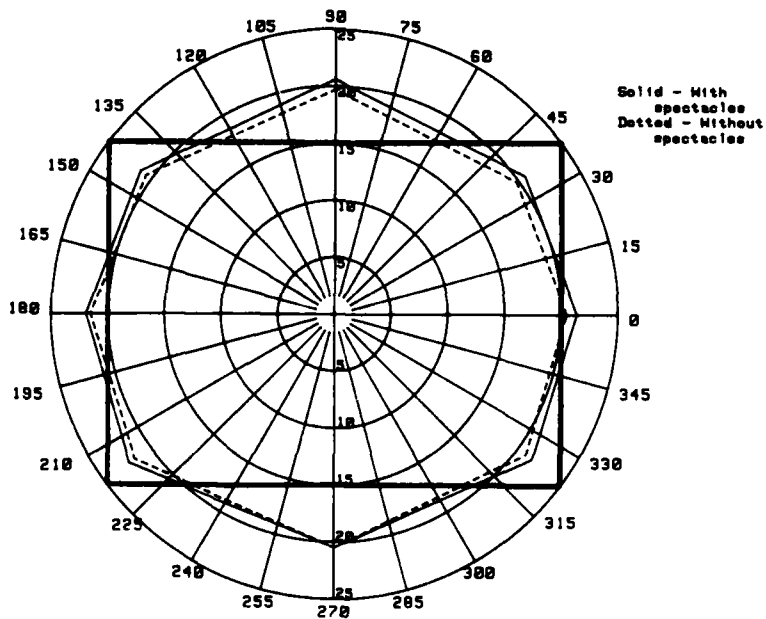

FIGURE 9. The measured fields for subject #5.

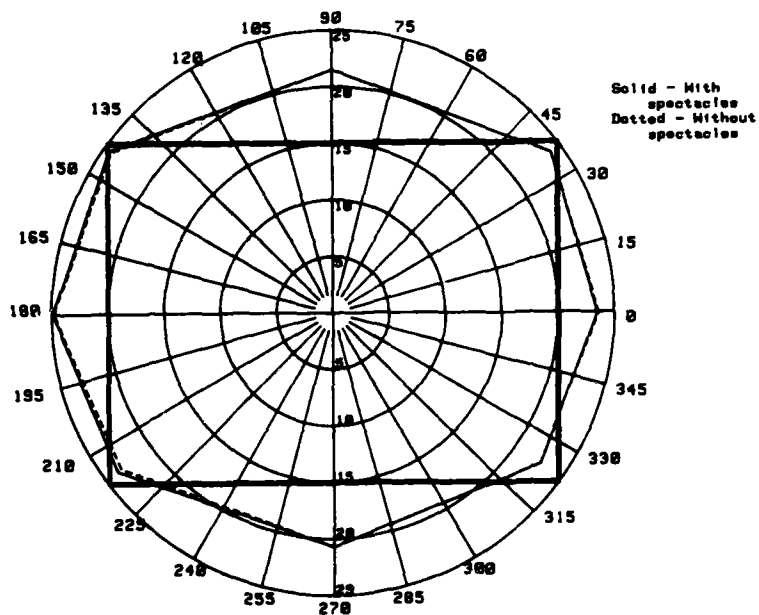

FIGURE 10. The measured fields for subject #6.

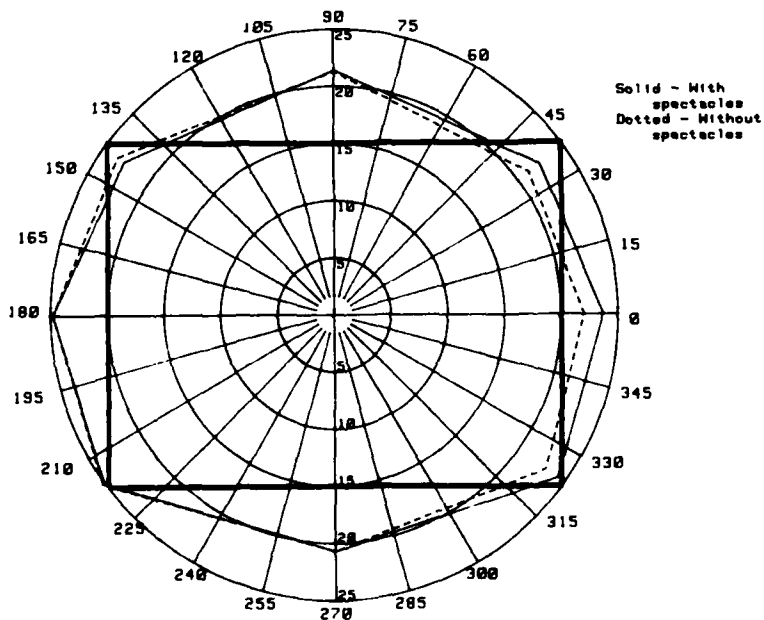

FIGURE 11. The measured fields for subject #7.

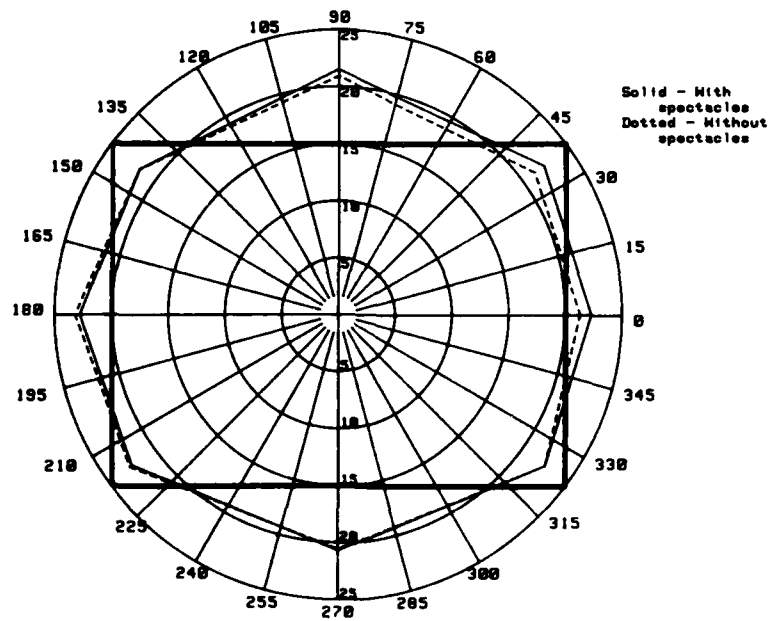

FIGURE 12. The measured fields for subject #8.

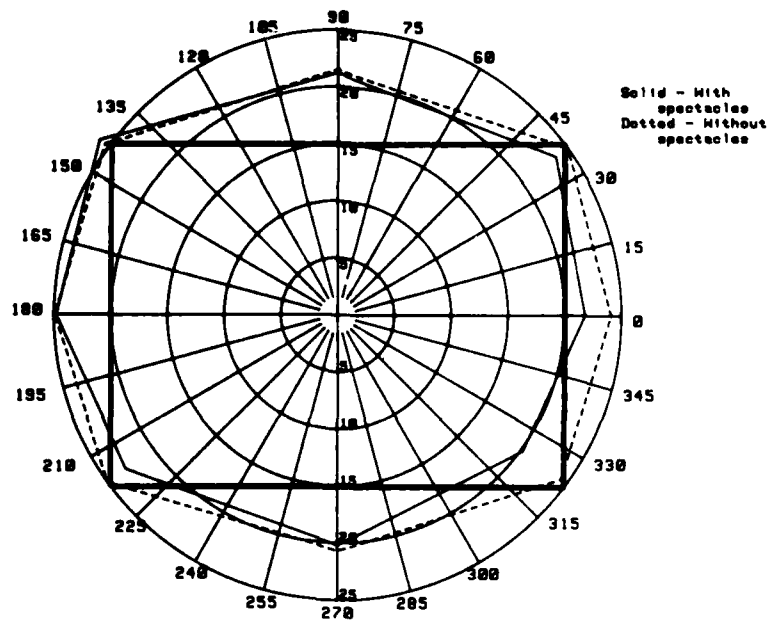

FIGURE 13. The measured fields for subject #9.

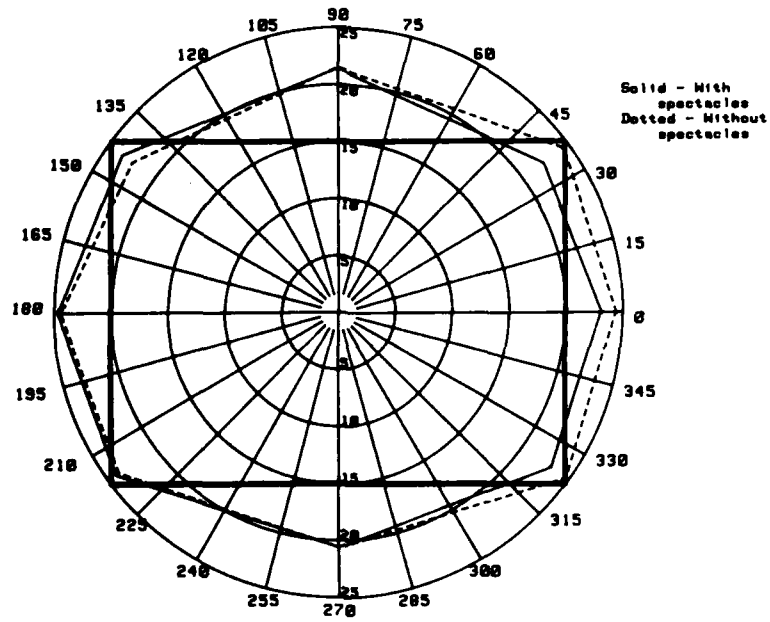

FIGURE 14. The measured fields for subject #10.

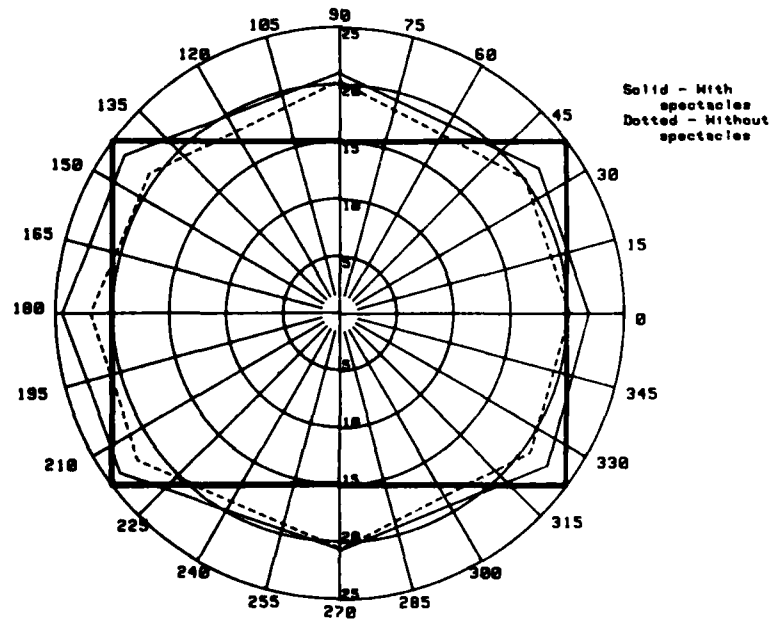

FIGURE 15. The measured fields for subject #11.

and 216, 90 and 270, and 144 and 324 degrees. Table 1 presents the measured fields for these colinear pairs for the two conditions. The values presented are the sums of the measurements for the two colinear meridians.

Whether the data in Table 1 are studied with respect to all meridional pairs for each subject or for all subjects for each meridional pair, the differences between with and without spectacles conditions are very small. Between subjects only subjects #9 and #11 have any real differences between the means for the two conditions when calculated across all meridians. The statistics presented for each meridional pair across all subjects indicate again very small differences between the two conditions.

The larger range in the without spectacles data, indicated by the larger standard deviation values, as compared to the with spectacles condition data, is most likely due to anatomical features that play a greater role in the placement of the HDU for the without spectacles condition. When the spectacles are worn, less variation in "eye relief" distance is possible.

The data in Table 1 are better expressed if converted into the actual amount of field lost or gained. These calculated values are given in Table 2. Gains for any meridional pair are given as positive values while losses are expressed as negative values. The values listed in parentheses are the losses or gains expressed in percent of the field available for the without spectacles condition. The last two columns in Table 2 attempt to use a single number to quantify an overall change in field between the two conditions. The next to the last column in Table 2 gives the mean losses or gains over all four colinear meridional pairs for each subject. These losses or gains are expressed in degrees and also as a percentage. The last column of Table 2 gives the mean calculated only for the losses for each subject across all meridional pairs. The last row in this table gives the means for losses only across all subjects for each meridional pair.

The calculations based on losses only are meaningful in the following way: The presence of the spectacles cannot decrease "eye relief" distance, but it can increase it. Therefore, any field gains with low power lenses, as used in this study, cannot be attributed to the presence of the spectacles, but only to fitting differences. Thus, the means based on losses only reflect more accurately the possible operational effects on the IHADSS system.

TABLE 1

COLLINEAR MERIDIONAL FIELDS FOR CONDITIONS WITH AND WITHOUT SPECTACLES (IN DEGREES)

Meridians Subject #	0 + 180 deg		36 + 216 deg		90 + 270 deg		144 + 314 deg		Mean	
	Y	N	Y	N	Y	N	Y	N	Y	N
1	46.5	48.0	45.5	46.8	41.8	41.6	45.2	46.6	44.8	45.8
2	46.8	46.6	45.9	46.4	42.1	42.2	45.5	46.5	45.1	45.4
3	46.2	46.2	45.0	44.8	41.6	41.9	45.9	45.0	44.7	44.5
4	45.2	44.2	44.8	43.4	41.5	41.5	43.7	43.0	43.8	43.0
5	43.3	42.0	43.0	41.5	41.1	40.2	42.8	41.5	42.6	41.3
6	48.4	48.4	47.7	47.3	42.2	42.2	47.3	47.0	46.4	46.2
7	48.5	46.8	47.5	46.4	42.1	42.0	47.1	46.5	46.3	45.4
8	45.1	44.5	44.8	44.0	42.2	41.5	44.2	44.2	44.1	43.6
9	46.6	49.0	46.7	50.0	41.4	42.2	46.2	49.8	45.3	47.8
10	47.8	48.8	46.5	48.4	42.0	42.1	46.6	47.1	45.7	46.6
11	46.3	42.1	45.4	42.0	41.7	40.9	46.0	41.4	44.9	41.6
High Value	48.5	49.0	47.7	50.0	42.2	42.2	47.3	49.8	46.4	47.8
Median	46.5	46.6	45.5	46.4	41.8	41.9	45.9	46.5	44.9	45.4
Low Value	43.3	42.0	43.0	41.5	41.1	40.2	42.8	41.4	42.6	41.3
Mean	46.4	46.1	45.7	45.5	41.8	41.7	45.5	45.3	44.9	44.7
SD	1.52	2.53	1.35	2.65	0.36	0.63	1.42	2.59	1.16	2.10

Note: The conditions with and without spectacles are denoted by the letters (Y) and (N), respectively.

TABLE 2

COLINEAR MERIDIONAL LOSSES OR GAINS (IN DEGREES)

Meridians Subject #	0 + 180 deg	36 + 216 deg	90 + 270 deg	144 + 314 deg	Mean	Mean Losses only
1	-1.5 (3.0%)	-1.3 (2.8%)	0.2 (0.5%)	-1.4 (3.0%)	-1.0 (2.1%)	-1.4 (2.9%)
2	0.2 (0.4%)	-0.5 (1.0%)	-0.1 (0.2%)	-1.0 (2.2%)	-0.4 (0.8%)	-0.5 (1.1%)
3	0.0 (—)	0.2 (0.4%)	-0.3 (0.7%)	0.9 (2.0%)	0.2 (0.4%)	-0.3 (0.7%)
4	1.0 (2.3%)	1.3 (3.3%)	0.0 (—)	0.7 (1.6%)	0.8 (1.8%)	0.0 (—)
5	1.3 (3.0%)	2.5 (3.6%)	0.9 (2.2%)	1.3 (3.1%)	1.5 (3.0%)	0.0 (—)
6	0.0 (—)	0.4 (0.8%)	0.0 (—)	0.3 (0.6%)	0.2 (0.4%)	0.0 (—)
7	1.7 (3.6%)	1.1 (2.4%)	0.1 (0.2%)	0.6 (1.3%)	0.9 (1.9%)	0.0 (—)
8	0.6 (1.3%)	0.8 (1.8%)	0.7 (1.7%)	0.0 (—)	0.5 (0.3%)	0.0 (—)
9	-2.4 (4.9%)	-3.3 (6.6%)	-0.8 (1.9%)	-3.6 (7.2%)	-2.5 (5.2%)	-2.5 (5.2%)
10	-1.0 (2.0%)	-1.9 (3.9%)	-0.1 (0.2%)	-0.5 (1.1%)	-0.9 (1.8%)	-0.9 (1.8%)
11	4.2 (10.0%)	3.4 (8.1%)	0.8 (2.0%)	4.6 (11.1%)	3.3 (7.8%)	0.0 (—)
Mean	-1.63 (3.3%)	-1.75 (3.6%)	-0.33 (0.8%)	-1.63 (3.4%)	----	----
Losses only						

The tables show only subjects #9 and #11 as having any significant differences in fields for the two conditions. However, if the field values (Table 1) for both conditions are compared to the values for the other subjects, it is seen that subject #9, even with the loss, maintains a field as large as any other subject. One other subject (#5) shows a small average gain of 1.5 degrees in the overall available field.

The summary statistics in both tables for the vertical meridional pair of 90 and 270 degrees need further comment. Because of the restrictions on the raster size which can be presented, the available field along these meridians produces artificially smaller gains than may actually be present due to fitting variations.

The data presented so far are directly applicable to the question of the effect of the modified spectacles on field-of-view. However, to conclude from the data the actual effects on the IHADSS field-of-view requires that the data be evaluated in view of the actual 30-by 40-degree field presented by the IHADSS. With this condition imposed, only colinear meridional values less than 30 degrees vertically, 40 degrees horizontally, and 50 degrees diagonally reflect real losses that occur in the IHADSS. No such losses are shown in Table 1 for the vertical meridional pair (90 + 270 degrees) or the horizontal meridional pair (0 + 180 degrees). However, losses are noted for both diagonal meridional pairs. This means that only the diagonal losses given in Table 2 actually impact the IHADSS. Table 2 shows that four of the subjects have losses between the two conditions along both diagonal meridional pairs. Only subject #9 exhibits a significant loss between the two conditions.

Figure 16 shows the results for the single subject (#6) tested for the effects on the visual fields with changes in eye relief and fixation direction. The subject was wearing the modified spectacles for these procedures. Measurements of the subject's field were made using five eye relief distances and two fixation directions. The eye relief distance was varied by changing the HDU extension in four of the cases and by adding a combiner distance change in the fifth case. A center fixation point and a peripheral fixation in the target direction were used.

The zero point on the x-axis represents the HDU in its most forward position. The minus position values on the x-axis refer to the distance in millimeters that the HDU was moved backwards toward the eye. For these positions, the combiner was positioned such that the base of the combiner maintained a 3 mm distance from the objective lens of the HDU. The +14 mm value on the x-axis is the condition where the HDU was positioned at its most forward position and the combiner was moved to its

maximum height of 17 mm from the objective lens. Field-of-view values on the y-axis were calculated by averaging the diagonal and horizontal colinear meridional pair values. The vertical meridional values were excluded because of the raster restrictions on their maximum values.

The central and peripheral fixation functions show essentially a parallel relationship with increased eye relief. For a given meridian, the difference in the field-of-view between central and peripheral eye fixations varies from approximately 2 degrees (4 degrees for colinear pair diameter) at minimum eye relief to approximately 3 degrees (6 degrees for colinear pair diameter) at the outer position limit of the HDU and combiner. The theoretical effect of this reduced field-of-view on the video imagery from the 40-by 30-degree rectangular FLIR raster is presented in Table 3 and in Figure 17. The assumption is made that the available field-of-view through the HDU essentially is circular. In Table 3 it can be seen that the subject would require a 50-degree field value in order not to suffer any losses in the corners of the raster. For the subject investigated, the 2 to 3 degrees meridional lost at the minimum HDU extension, due to variation in choice of fixation, corresponds to an increase in unavailable field approximately from 0.4 percent with center fixation to 3.0 percent with peripheral fixation. For the maximum eye relief distance, the corresponding field loss from change in fixation is approximately from 12 percent with center fixation to 30 percent with peripheral fixation. It should be noted that even for the optimum fixation direction (central), the single subject tested suffered an increase in unavailable field at the diagonals from 0.4 degrees to 10.4 degrees with the combiner positioned at the maximum eye relief position. This confirms the previously-stated assumption that to maximize the available field-of-view, the eye relief distance must be minimized; the ability to properly adjust the HDU and minimize eye relief is more highly dependent on anatomical features and helmet fit than any other known characteristics.

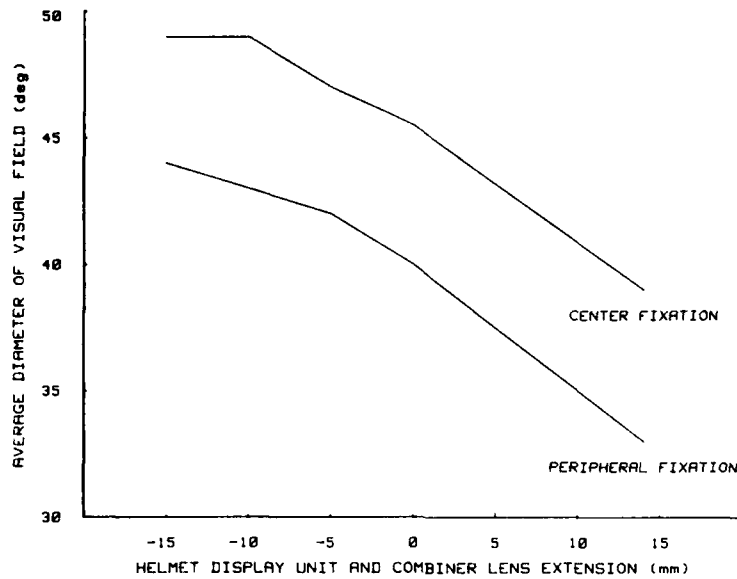

FIGURE 16. The effects of eye relief and fixation point on available field-of-view.

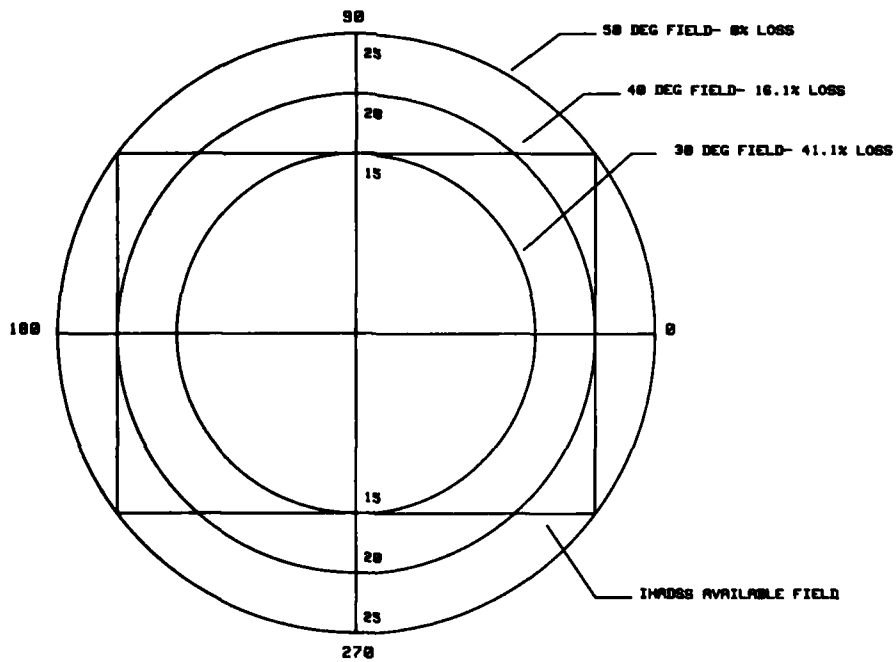

FIGURE 17. Theoretical loss of available field.

TABLE 3

PERCENT OF UNAVAILABLE FIELD

Colinear Field Value (in degrees)	Field Loss
30	41.1
32	34.1
34	28.0
36	21.9
38	16.1
40	10.4
42	6.3
44	3.4
46	1.4
48	0.4
50	0.0

The visual effect from the decrease in the field-of-view from peripheral fixation needs to be clarified. If the subject is fixating centrally, he can detect information in the peripheral video imagery, but will need to fixate on the detected object for identification. His field-of-view will then be reduced as a result of that fixation in the periphery. The best approach is to move his head to keep the object visible when it appears at the outer limits of the display. In the case of the IHADSS symbology, which is fixed in position on the peripheral edges of the display, the subject must look directly at the numerals and symbols to interpret the information.

CONCLUSIONS AND RECOMMENDATIONS

Considering the limited sample size, this study indicates that when sufficient care is taken in the fit and alignment of the helmet and HDU, there is no significant loss from the modified spectacles in the available field-of-view.

Generally speaking, the determining factors of the available field are helmet fit, fixation direction, and eye relief distance. Helmet fit, while dependent on anatomical features, is affected most by the care exercised during the fitting process. The percent field loss caused by peripheral fixation can range between 3 and 30 percent and is highly

dependent on eye relief distance. Minimum eye relief, obtained by decreasing the HDU and combiner extension, is desired. For center fixation, for one subject, the unavailable field increased from approximately 0.4 to 12 percent due to HDU and combiner distance variation. The ability to minimize these distances is influenced greatly by anatomical features and is extremely important to being able to acquire the peripheral symbology. The modified spectacles could be worn by the subjects tested without measurable increase in eye relief.

It is recommended that spectacles be utilized with the IHADSS whenever their use is required for correction of refractive errors or for laser protection until suitable alternatives have been identified, tested, and proven. Directions to spectacle wearers should emphasize the importance of a proper helmet fit and combiner alignment. During the fitting care should be taken to minimize the extension of the HDU and the combiner element.

APPENDIX A

LIST OF EQUIPMENT MANUFACTURERS

Hewlett-Packard
2000 South Park Place
Atlanta, Georgia 30339

Tetronix, Inc.
4900 S.W. Griffith Drive
Beaverton, Oregon 97077

INITIAL DISTRIBUTION

Commander
US Army Natick Research &
Development Center
ATTN: Documents Librarian
Natick, MA 01760

Commander
US Army Research Institute of
Environmental Medicine
Natick, MA 01760

Naval Submarine Medical Research
Laboratory
Medical Library, Naval Submarine Base
Box 900
Groton, CT 05340

US Army Avionics Research &
Development Activity
ATTN: SAVAA-P-TP
Fort Monmouth, NJ 07703-5401

Commander/Director
US Army Combat Surveillance &
Target Acquisition Laboratory
ATTN: DELCS-D
Fort Monmouth, NJ 07703-5304

US Army Research & Development
Support Activity
Fort Monmouth, NJ 07703

Commander
10th Medical Laboratory
ATTN: Audiologist
APO New York 09180

Chief
Benet Weapons Laboratory
LCWSL, USA ARRADCOM
ATTN: DRDAR-LCB-TL
Watervliet Arsenal
Watervliet, NY 12189

Commander
Naval Air Development Center
Biophysics Laboratory (ATTN: G. Kydd)
Code 60B1
Warminster, PA 18974

Commander
Man-Machine Integration System (Code 602)
Naval Air Development Center
Warminster, PA 18974

Naval Air Development Center
Technical Information Division
Technical Support Detachment
Warminster, PA 18974

Commander
Naval Air Development Center
ATTN: Code 6021 (Mr. Brindle)
Warminster, PA 18974

Dr. E. Hendler
Human Factors Applications, Inc.
295 West Street Road
Warminster, PA 18974

Uniformed Services University
of the Health Sciences
4301 Jones Bridge Road
Bethesda, MD 20014

Commanding Officer
Naval Medical Research &
Development Command
National Naval Medical Center
Bethesda, MD 20014

Under Secretary of Defense for
Research & Engineering
ATTN: Military Assistant for
Medical and Life Sciences
Washington, DC 20301

Director
Army Audiology & Speech Center
Walter Reed Army Medical Center
Washington, DC 20307-5001

COL Franklin H. Top, Jr., MD
Walter Reed Army Institute
of Research
Washington, DC 20307-5100

Commander
US Army Institute of Dental Research
Walter Reed Army Medical Center
Washington, DC 20307-5300

Naval Air Systems Command
Technical Library Air 950D
Rm 278, Jefferson Plaza II
Department of the Navy
Washington, DC 20361

Naval Research Laboratory Library
Code 1433
Washington, DC 20375

Naval Research Laboratory Library
Shock & Vibration Information Center
Code 5804
Washington, DC 20375

Harry Diamond Laboratories
ATTN: Technical Information Branch
2800 Powder Mill Road
Adelphi, MD 20783-1197

Director
US Army Human Engineering Laboratory
ATTN: Technical Library
Aberdeen Proving Ground, MD 21005-5001

US Army Materiel Systems
Analysis Agency
ATTN: Reports Processing
Aberdeen Proving Ground, MD 21005-5017

Commander
US Army Test & Evaluation Command
ATTN: AMSTE-AD-H
Aberdeen Proving Ground, MD 21005-5055

US Army Ordnance Center &
School Library
Bldg 3071
Aberdeen Proving Ground, MD 21005-5201

Director
US Army Ballistic Research Laboratory
ATTN: DRXBR-OD-ST (Technical Reports)
Aberdeen Proving Ground, MD 21005-5066

US Army Environmental Hygiene
Agency Library
Bldg E2100
Aberdeen Proving Ground, MD 21010

Commander
US Army Medical Research Institute
of Chemical Defense
ATTN: SGRD-UV-AO
Aberdeen Proving Ground, MD 21010-5425

Technical Library
Chemical Research & Development Center
Aberdeen Proving Ground, MD 21010-5423

Commander
US Army Medical Research &
Development Command
ATTN: SGRD-RMS (Mrs. Madigan)
Fort Detrick, MD 21701-5012

Commander
US Army Medical Research Institute
of Infectious Diseases
Fort Detrick, Frederick, MD 21701

Commander
US Army Medical Bioengineering Research
& Development Laboratory
ATTN: SGRD-UBZ-I
Fort Detrick, Frederick, MD 21701

Dr. R. Newburgh
Director of Biological Sciences Division
Office of Naval Research
600 North Quincy Street
Arlington, VA 22217

Defense Technical Information Center
Cameron Station
Alexandria, VA 22314

US Army Materiel Development &
Readiness Command
5001 Eisenhower Avenue
Alexandria, VA 22333

US Army Foreign Science &
Technology Center
ATTN: MTZ
220 7th Street, NE
Charlottesville, VA 22901-5396

Commandant
US Army Aviation Logistics School
ATTN: ATSQ-TDN
Fort Eustis, VA 23604

Director
Applied Technology Laboratory
USARTL-AVSCOM
ATTN: Library, Bldg 401
Fort Eustis, VA 23604

US Army Training & Doctrine Command
ATTN: ATCD-ZX
Fort Monroe, VA 23651

Commander
US Army Training & Doctrine Command
ATTN: Surgeon
Fort Monroe, VA 23651-5000

Structures Laboratory Library
USARTL-AVSCOM
NASA Langley Research Center
Mail Stop 266
Hampton, VA 23665

Naval Aerospace Medical
Institute Library
Bldg 1953, Code 102
Pensacola, FL 32508

US Air Force Armament Development
& Test Center
Eglin Air Force Base, FL 32542

Command Surgeon
US Central Command
MacDill AFB, FL 33608

US Army Missile Command
Redstone Scientific Information Center
ATTN: Document Section
Redstone Arsenal, AL 35898-5241

Air University Library
(AUL/LSE)
Maxwell AFB, AL 36112

Commander
US Army Aeromedical Center
Fort Rucker, AL 36362

Commander
US Army Aviation Center &
Fort Rucker
ATTN: ATZQ-CDR
Fort Rucker, AL 36362

Director
Directorate of Combat Developments
Bldg 507
Fort Rucker, AL 36362

Director
Directorate of Training Development
Bldg 502
Fort Rucker, AL 36362

Chief
Army Research Institute Field Unit
Fort Rucker, AL 36362

Commander
US Army Safety Center
Fort Rucker, AL 36362

Commander
US Army Aviation Center &
Fort Rucker
ATTN: ATZQ-T-ATL
Fort Rucker, AL 36362

Commander
US Army Aircraft Development
Test Activity
ATTN: STEBG-MP-QA
Cairns AAF
Ft Rucker, AL 36362

President
US Army Aviation Board
Cairns AAF
Fort Rucker, AL 36362

US Army Research & Technology
Laboratories (AVSCOM)
Propulsion Laboratory MS 302-2
NASA Lewis Research Center
Cleveland, OH 44135

AFAMRL/HEX
Wright Patterson AFB, OH 45433

US Air Force Institute of
Technology (AFIT/LDEE)
Bldg 640, Area B
Wright-Patterson AFB, OH 45433

John A. Dellinger, MS, ATP
University of Illinois - Willard Airport
Savoy, IL 61874

Henry L. Taylor
Director
Institute of Aviation
University of Illinois - Willard Airport
Savoy, IL 61874

Commander
US Army Aviation Systems Command
ATTN: DRSAV-WS
4300 Goodfellow Boulevard
St. Louis, MO 63120-1798

Project Officer
Aviation Life Support Equipment
ATTN: AMCPO-ALSE
4300 Goodfellow Boulevard
St. Louis, MO 63120-1798

Commander
US Army Aviation Systems Command
ATTN: SGRD-JAX-AL (MAJ Lacy)
Bldg 105, 4300 Goodfellow Boulevard
St. Louis, MO 63120

Commander
US Army Aviation Systems Command
ATTN: DRSAV-ED
4300 Goodfellow Boulevard
St. Louis, MO 63120

US Army Aviation Systems Command
Library & Information Center Branch
ATTN: DRSAV-DIL
4300 Goodfellow Boulevard
St. Louis, MO 63120

Commanding Officer
Naval Biodynamics Laboratory
P.O. Box 24907
New Orleans, LA 70189

Federal Aviation Administration
Civil Aeromedical Institute
CAMI Library AAC 64D1
P.O. Box 25082
Oklahoma City, OK 73125

US Army Field Artillery School
ATTN: Library
Snow Hall, Room 14
Fort Sill, OK 73503

Commander
US Army Academy of Health Sciences
ATTN: Library
Fort Sam Houston, TX 78234

Commander
US Army Health Services Command
ATTN: HSOP-SO
Fort Sam Houston, TX 78234-6000

Commander
US Army Institute of Surgical Research
ATTN: SGRD-USM (Jan Duke)
Fort Sam Houston, TX 78234-6200

Director of Professional Services
AFMSC/GSP
Brooks Air Force Base, TX 78235

US Air Force School of
Aerospace Medicine
Strughold Aeromedical Library
Documents Section, USAFSAM/TSK-4
Brooks Air Force Base, TX 78235

US Army Dugway Proving Ground
Technical Library
Bldg 5330
Dugway, UT 84022

Dr. Diane Damos
Psychology Department
Arizona State University
Tempe, AZ 85287

US Army Yuma Proving Ground
Technical Library
Yuma, AZ 85364

US Army White Sands Missile Range
Technical Library Division
White Sands Missile Range
New Mexico, 88002

US Air Force Flight Test Center
Technical Library, Stop 238
Edwards Air Force Base, CA 93523

US Army Aviation Engineering
Flight Activity
ATTN: SAVTE-M (Tech Library) Stop 217
Edwards Air Force Base, CA 93523-5000

Commander
Code 3431
Naval Weapons Center
China Lake, CA 93555

US Army Combat Developments
Experimental Center
Technical Information Center
Bldg 2925
Fort Ord, CA 93941-5000

Aeromechanics Laboratory
US Army Research &
Technical Laboratories
Ames Research Center, M/S 215-1
Moffett Field, CA 94035

Commander
Letterman Army Institute of Research
ATTN: Medical Research Library
Presidio of San Francisco, CA 94129

Sixth US Army
ATTN: SMA
Presidio of San Francisco, CA 94129

Director
Naval Biosciences Laboratory
Naval Supply Center, Bldg 844
Oakland, CA 94625

Col G. Stebbing
USDAO-AMLO, US Embassy
Box 36
FPO New York 09510

Staff Officer, Aerospace Medicine
RAF Staff, British Embassy
3100 Massachusetts Avenue, NW
Washington, DC 20008

Canadian Society of Aviation Medicine
c/o Academy of Medicine, Toronto
ATTN: Ms. Carmen King
288 Bloor Street West
Toronto, Ontario M5S 1V8

Canadian Air Line Pilot's Association
MAJ J. Soutendam (Retired)
1300 Steeles Avenue East
Brampton, Ontario, L6T 1A2

Canadian Forces Medical Liaison Officer
Canadian Defence Liaison Staff
2450 Massachusetts Avenue, NW
Washington, DC 20008

Commanding Officer
404 Squadron CFB Greenwood
Greenwood, Nova Scotia BOP 1N0

Officer Commanding
School of Operational &
Aerospace Medicine
DCIEM, P.O. Box 2000
1133 Sheppard Avenue West
Downsview, Ontario M3M 3B9

National Defence Headquarters
101 Colonel By Drive
ATTN: DPM
Ottawa, Ontario K1A 0K2

Canadian Army Liaison Office
Bldg 602
Fort Rucker, AL 36362

Netherlands Army Liaison Office
Bldg 602
Fort Rucker, AL 36362

German Army Liaison Office
Bldg 602
Fort Rucker, AL 36362

British Army Liaison Office
Bldg 602
Fort Rucker, AL 36362

French Army Liaison Office
Bldg 602
Fort Rucker, AL 36362

END

FILMED

1-85

DTIC