

AD-A148 619

THE USE OF MICRODIELECTROMETRY IN MONITORING THE CURE
OF RESINS AND COMPO. (U) WESTINGHOUSE RESEARCH AND
DEVELOPMENT CENTER PITTSBURGH PA 2 N SANJANA SEP 84
9871-CURES-R2 N00014-82-C-0164

1/1

UNCLASSIFIED

F/G 13/8

NL

					END								
					FORMED								
					DTC								

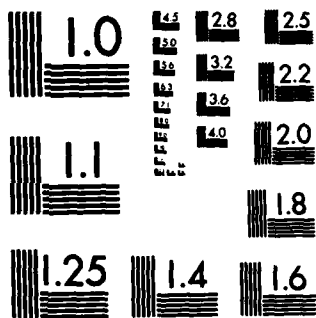

MICROCOPY RESOLUTION TEST CHART
NATIONAL BUREAU OF STANDARDS-1963-A

AD-A148 619

THE USE OF MICRODIELECTROMETRY IN
MONITORING THE CURE OF RESINS AND
COMPOSITES

12

Z. N. Sanjana
Principal Investigator

Technical Report No. 2

September 1984

Department of the Navy
Office of Naval Research
Contract No. N00014-82-C-0164

DTIC FILE COPY

DTIC
ELECTE
DEC 14 1984
S B D

DISTRIBUTION STATEMENT A

Approved for public release
Distribution Unlimited



Westinghouse R&D Center
1310 Beulah Road
Pittsburgh, Pennsylvania 15235

84 12 06 029

THE USE OF MICRODIELECTROMETRY IN
MONITORING THE CURE OF RESINS AND
COMPOSITES

Z. N. Sanjana
Principal Investigator

Technical Report No. 2

September 1984

Department of the Navy
Office of Naval Research
Contract No. N00014-82-C-0164

DTIC
ELECTE
DEC 14 1984
S D
B

DISTRIBUTION STATEMENT A
Approved for public release
Distribution Unlimited



Westinghouse R&D Center
1310 Beulah Road
Pittsburgh, Pennsylvania 15235

REPORT DOCUMENTATION PAGE		READ INSTRUCTIONS BEFORE COMPLETING FORM
1. REPORT NUMBER	2. GOVT ACCESSION NO.	3. RECIPIENT'S CATALOG NUMBER
4. TITLE (and Subtitle) THE USE OF MICRODIELECTROMETRY IN MONITORING THE CURE OF RESINS AND COMPOSITES		5. TYPE OF REPORT & PERIOD COVERED Technical Report No. 2 1/84 to 7/84
		6. PERFORMING ORG. REPORT NUMBER 84-9B7-CURES-R2
7. AUTHOR(s) Z. N. Sanjana		8. CONTRACT OR GRANT NUMBER(s) N00014-82-C-0164
9. PERFORMING ORGANIZATION NAME AND ADDRESS Westinghouse Electric Corp. R&D Center - 1310 Beulah Rd. Pittsburgh, PA 15235		10. PROGRAM ELEMENT, PROJECT, TASK AREA & WORK UNIT NUMBERS
11. CONTROLLING OFFICE NAME AND ADDRESS Department of the Navy Office of Naval Research 800 N. Quincy St., Arlington, VA 22217		12. REPORT DATE 9/84
		13. NUMBER OF PAGES
14. MONITORING AGENCY NAME & ADDRESS (if different from Controlling Office)		15. SECURITY CLASS. (of this report) Unclassified
		15a. DECLASSIFICATION/DOWNGRADING SCHEDULE
16. DISTRIBUTION STATEMENT (of this Report) This document has been approved for public release. Distribution unlimited.		
17. DISTRIBUTION STATEMENT (of the abstract entered in Block 20, if different from Report)		
18. SUPPLEMENTARY NOTES This document to be published in Proceedings of INSULEC - 84 (International Seminar & Exhibition on Electrical Insulation), December 1984, Bombay, India.		
19. KEY WORDS (Continue on reverse side if necessary and identify by block number) DIELECTRIC. ANALYSIS. MEASUREMENT. CURING. PERMITTIVITY. LOSS FACTOR. MONITORS. SENSORS. EPOXY. LAMINATES. PREPREG. RESINS. MICRODIELECTROMETRY.		
20. ABSTRACT (Continue on reverse side if necessary and identify by block number) see reverse side		

Block 20 (Abstract)

As thermosetting resins and composites made from them begin to be used in critical applications, it becomes necessary to monitor and analyze the cure of the resin within the confines of the processing equipment. Such measurements have been carried out using a dielectric technique called dielectrometry or dielectric analysis. Conventional dielectrometry has certain limitations associated with the use of parallel plate geometry for electrodes. For in situ measurement of cure, intrusiveness of electrodes is a problem which may require placement of electrodes in non-strategic areas. Since electrode spacing changes during cure, it is difficult to deduce permittivity and loss factor from the data. At lower frequencies the capacitive currents are small and signal-to-noise ratios are small, therefore, measurement at low frequencies (<100 Hz) typically require large electrode sizes.

One approach to overcome the problems described above is the development of microdielectrometry. A solid state integrated circuit chip, 2 mm x 4 mm in size, is used as the sensor. The miniature sensor can measure the properties of a dielectric on its surface, therefore it need not intrude into the composite part. Transistors which are built into the integrated circuit are used to amplify the signal to make low frequency (<1 Hz) measurements feasible. The electrode geometry does not change, therefore loss factor and permittivity data can be deduced in real-time. During cure of the resin or composite material, permittivity and loss factor are measured continuously at a series of preselected frequencies. Real-time data is plotted on a strip chart and is also stored in a cassette for later analysis. Temperature of the curing material is measured either by a diode on the sensor or by externally placed thermocouples.

Results on an aromatic amine cured epoxy resin and a dicyandiamide cured epoxy resin prepreg are presented in this report. The data obtained by microdielectrometry is compared and correlated to results obtained using differential scanning calorimetry, infrared analysis and dynamic mechanical analysis. Results show that microdielectrometry can be used to follow the cure of epoxy resins and absolute measurements of permittivity and loss factor can be made to provide information on the mechanisms that produce the observed changes. Data at 1 Hz can be obtained but for certain lossy systems at typical cure temperatures, the data is often out of range of the instrument, thus restricting use to 10 Hz and higher frequencies. At very high loss factors (>100) a "blocking" phenomena is observed due to charge pile up at electrode surfaces which results in erroneously high permittivity values.

FORWARD

The following report describes part of the work performed under ONR Contract No. N00014-82-C-0164, "Monitor Cure of Composites and Evaluate Cure Monitoring Procedures". This report (Report No. 2) covers the work done with Micromet System I and a flat ribbon sensor which permits working with composites. Report No. 1 covered work done on studying the cure of epoxy resins using a TO-8 header mounted sensor and System I instrumentation. The final, Report No. 3 will cover work done with Micromet System II in which the gain phase meter of System I is replaced with a Micromet developed fourier transform analyzer which increases system sensitivity and reduces system noise.

This program was administered for ONR by Dr. L. H. Peebles, Jr. The program was conducted entirely at the Westinghouse Electric Corp., R&D Center, in the Polymer and Composite Research Department with Z. N. Sanjana as Principal Investigator.

Accession For	
NTIS AD&I	<input checked="" type="checkbox"/>
DTIC TAB	<input type="checkbox"/>
Unannounced	<input type="checkbox"/>
Justification	
By _____	
Distribution/	
Availability Codes	
Dist	Avail and/or Special
A-1	



THE USE OF MICRODIELECTROMETRY IN MONITORING
THE CURE OF RESINS AND COMPOSITES*

Z. N. Sanjana
Westinghouse Electric Corporation
R&D Center
Pittsburgh, PA, USA

1. INTRODUCTION

As thermosetting resins and advanced composites made from them begin to be used in critical applications it becomes necessary to monitor the cure of the thermosetting resins within the confines of the processing equipment. Such measurements of cure have been carried out by several investigators using a dielectric technique generally called dielectric analysis.⁽¹⁻⁶⁾ In conventional dielectric analysis the sample to be examined is placed between two parallel conducting plates or electrodes and the ac capacitance and dissipation factor are measured using a device called an automatic dielectrometer. One such automatic dielectrometer, popularly called by its acronym Audrey, has been frequently used. It provides a continuous output of dissipation factor and capacitance as a function of time, temperature and frequency (from 0.1 kHz to 100 kHz). It has been successfully used in studying parameters affecting cure⁽¹⁻³⁾, in situ monitoring of cure in

*Funding provided by Office of Naval Research.

an autoclave⁽⁴⁾, and features of the dielectric output have been related to changes in chemistry⁽⁵⁾.

There are certain problems associated with conventional dielectrometry, mainly centered around the use of the parallel plate geometry for electrodes. For in situ measurement of cure the placement and intrusiveness of the electrodes becomes an issue. Also, since parallel plate spacing can change during cure, it is difficult to deduce from the capacitance and dissipation factor curves the fundamental dielectric properties, permittivity and loss factor. The use of conductive fibers such as graphite and boron require special treatment of the sample geometry such as use of a "blocking" film. Furthermore, conventional dielectric methods depend on measuring the capacitive current flowing through the sample space which at low frequencies become very small and therefore signal-to-noise ratios become small.

Microdielectrometry^(6,7) is a technique developed as one approach to overcome some of the problems described above. Integrated circuit technology is used to develop a miniaturized probe that combines a small size with built-in amplification to measure dielectric properties of polymers at frequencies as low as 0.1 Hz. The integrated circuit device consists of a planar interdigitated electrode structure with a pair of matched field effect transistors. The electrode geometry does not change during cure and is reproducible from device to device.

Figure 1 shows the conceptual difference between parallel plate dielectrometry and microdielectrometry.

2. EXPERIMENTAL

A system consisting of instrumentation, software and the integrated circuit cure sensor was obtained from Micromet Instruments, Inc.⁽⁸⁾ It is shown schematically in Figure 2. The technology and relative advantages of microdielectrometry have been fully described by Senturia and co-workers^(6,7,9) and by us⁽¹⁰⁾. The system, in essence, takes the relative gain and phase of the sensor output compared to sensor input (imposed sinusoidal voltage under command from a programmed computer) and using an internally stored calibration converts the data into permittivity (ϵ'), loss factor (ϵ'') and their ratio the loss tangent or dissipation factor ($\tan \delta = \epsilon''/\epsilon'$). Thus ϵ' and ϵ'' can be measured for any material that is on the surface of the integrated circuit chip or sensor. The sensor consists of a 2 mm x 4 mm integrated circuit mounted in a flat cable package shown in Figure 3. Both electrodes used in the dielectric measurement are placed on the same surface to form an interdigitated capacitor and on-chip amplification produces high signal-to-noise ratios.⁽⁷⁾

Our measurements of the cure of epoxy resins were made by placing a drop of the curing mixture on the sensor surface. The flat cable connects the sensor to the sensor interface box as shown schematically in Figure 2. The sensor was then placed in an oven and the oven temperature was either ramped or controlled at a set temperature by means of a controller. Sample temperature was taken to be close to the oven temperature for the slow heat-up rates used in this study. This was verified by placing a thermocouple into the sensor and comparing the sensor temperature with the oven air temperature. Deviations were generally less than 1°C.

Cure of resin impregnated on fabric (prepreg) was monitored in a press. The sensor was placed in the composite or in a channel cut into the bottom caul plate which is shown in Figure 3. A thermocouple was also placed in the composite to monitor the temperature of the composite as it cured. The composite was cured under a pressure of 690 kPa (100 psi), which was applied as soon as the press was closed.

For economy of space $\tan \delta$ (dissipation factor) data is not presented in this report. Permittivity (ϵ') and loss factor (ϵ'') data are presented and $\tan \delta$ can always be calculated because $\tan \delta = \epsilon''/\epsilon'$.

The progress of cure for the laminates and resin was also followed using conventional techniques which are described below:

(1) FTIR: Samples of resin were cast on KBr pellets and analyzed on Nicolet Model 7000B Fourier transform infrared (FTIR) spectrophotometer after periodic intervals of cure. The films were scanned in a transmission mode 200 times, the spectra were averaged and the background spectrum was subtracted by computer techniques. The transmission spectra were converted to absorbance electronically, and peak heights were measured. Peak heights for bands representing reacting groups were normalized using peak heights for bands of non-reacting groups (reference peaks). Thus changes taking place in reactive groups could be monitored during cure. (5)

(2) DSC: Differential scanning calorimetry (DSC) can be used to follow the progress of resin or composite cure by measuring either the heat of residual reaction or the increase in T_g of the material. A Perkin Elmer DSC-2 with a Model 3600 microprocessor data station was used to obtain DSC

scans. Samples were removed from the curing environment at specific intervals of time, weighed and scanned at 20°C/min.

(3) DMA: A DuPont 982 dynamic mechanical analyzer (DMA) with a 1099 microprocessor controlled thermal analyzer was used to obtain tensile storage modulus (E'), tensile loss modulus (E'') and mechanical loss tangent ($\tan \delta$) data for laminates that were cured for different intervals of time.

The 982 DMA is a constant amplitude instrument. The sample is induced to vibrate at its natural frequency which depends on the sample stiffness and sample geometry. The instrument measures the natural frequency and damping or degree to which the sample dissipates energy. The thermal analyzer records the two parameters as a function of temperature. The microprocessor converts the raw data into modulus and $\tan \delta$ data which is then plotted as a function of temperature.

All DMA scans were obtained at a scanning rate of 5°C/min and the constant oscillating amplitude was set at 0.2 mm.

3. RESULTS AND DISCUSSION

Press Cure of Kevlar®-Epoxy Laminates

Style 120 Kevlar® fabric was impregnated with a standard epoxy laminating resin. (5) The resin consisted of a mixture of brominated and unbrominated epoxy resins with dicyandiamide as a curative catalyzed by

Registered trademark of E.I. DuPont de Nemours & Co.

benzyl dimethylamine. The formulation in parts-by-weight is: Dow Epoxy Resin DER 521-70, Dow Epoxy Resin DER 661-30, dicyandiamide-3, benzyl dimethylamine-0.25. The prepreg was made by dissolving the mix in methyl cellosolve/acetone solvent, dipping the fabric in the varnish and B-staging in a forced air oven for 5 mins @ 150°C. The resulting dry prepreg was cut, stacked and cured in a press.

Figure 4 shows the permittivity (ϵ') and loss factor (ϵ'') data for an isothermal cure of the prepreg placed in a hot press at 160°C temperature and 690 kPa pressure. The temperature profile of the laminate is also shown. The data shows that after 75 mins most of the reaction is over because both ϵ' and ϵ'' essentially become invariant with time. The lower frequencies exhibit higher sensitivity to cure by showing a greater absolute change in magnitude than do the higher frequencies.

Senturia, et al.⁽⁹⁾, have explained the loss factor data during cure as being the result of a combination of ionic conductivity effects and dipolar motion effects. Early in cure the conductivity effect is dominant, and the loss factor is inversely proportional to the frequency of measurement.⁽⁹⁾ Later in cure, depending on the final Tg of the resin, dipolar effects may dominate the loss factor data. In Figure 4 we note that initially the loss factor is inversely proportional to the frequency of the measurement and as the cure proceeds isothermally the conductivity and therefore the loss factor decline rapidly in value. No dipolar effects are noticed later in cure (see, e.g., Figure 8 to be discussed later). The loss factor, except at 10 kHz, remains inversely proportional to frequency of measurement indicating this resin is very lossy at 160°C and the

dielectric data is dominated by conductivity effects. The data of Figure 4 shows that initially, particularly at the lower frequencies, the permittivity is very high. This has been attributed by Senturia, et al.⁽⁹⁾ to the presence of "blocking" electrodes which result in an accumulation of ions at the electrode resin interface. The blocking effect would add a large capacitance due to polarization of the blocking layer to the normal capacitance of the cell. Extraction of permittivity from the much larger capacitance using the parallel resistance-capacitance model, which is generally correctly used, would result in a very high value for permittivity. This effect occurs in resins under temperature and frequency conditions when the conductivity is very high (i.e., generally early in cure, at higher temperatures and lower frequencies).

The microdielectrometry data showing early rapid reaction being essentially over in 75 mins was confirmed by DSC and FTIR measurements shown in Table 1. The T_g of the prepreg measured after the indicated time at temperature shows that the increase in T_g with cure is over in 70 mins. Residual exotherm is not measurable after 30 mins @ 160°C. The FTIR data is presented as ratio of peak heights. In order to normalize the data, absorbance peaks at 915 cm⁻¹ due to the epoxide group and 2200 cm⁻¹ due to -C≡N group of the curative dicyandiamide were compared to a reference peak at 830 cm⁻¹ caused by para substituted aromatic group in the epoxy resin. The latter is not affected by the reaction.⁽⁵⁾ During the cure the epoxide group is consumed and the reduction of the epoxy peak is over after 70 mins of reaction as is the reduction in the -C≡N functional group. 68% of the epoxy is consumed in the first 30 mins of reaction and after 70 mins, 81% of the epoxy is consumed.

A dynamic mechanical analyzer was also used to investigate the progress of cure of the Kevlar-epoxy prepreg. Laminates were

prepared as described above by isothermally curing them at 160°C in a press for different periods of time from 5 mins to 90 mins. The laminates were then scanned in the 982 DMA from RT to 140°C. For economy of space, only the tensile storage modulus (E') data is shown in Figure 5. Since the data was collected on a series of laminates prepared individually, the resin content for each laminate was different and is also presented in Figure 5. As the cure proceeds, the storage modulus curve shifts to increasing temperatures. This in essence is due to the increasing T_g of the resin with cure. Above T_g the resin is in a rubbery phase and no longer has the stiffness that it had below T_g when it is in a glassy phase. The break in the modulus curve occurs at or close to the T_g of the resin. Figure 5 data shows that the shift of the modulus curve to higher temperatures continues till 50 mins of cure at 160°C have elapsed. After that no further gain in modulus with temperature is indicated. This agrees with the DSC data of Table 1. Differences in the magnitude of the glassy state ($<T_g$) modulus of the various laminates can largely be accounted for by differences in the resin content of the laminates.

The data of Figures 4 and 5 and Table 1 indicate that micro-dielectrometry can sensitively follow the progress of cure of an epoxy prepreg and the end of cure indication (75 mins at 160°C) correlates well with FTIR, DSC and DMA measurements. Some small differences that exist can be attributed to the different scales of the various experiments and consequently different heat-up rates.

In general prepregs are not cured isothermally. Microdielectrometry data for cure of the same Kevlar-epoxy prepreg with the press initially

at room temperature is presented in Figure 6. The temperature was ramped at 2°C/min to a final cure temperature of 180°C. The loss factor (ϵ'') data is more useful in following cure because it is not affected by the formation of a blocking electrode as is the permittivity data. Initially the loss factor is zero because there is no resin on the surface of the sensor. Then as heat is applied to the prepreg stack the resin melts and flows on to the sensor surface. When that happens the loss factor readings come on-scale and increase with increasing temperature of the resin because the conductivity of the resin increases with reduction in viscosity.⁽⁹⁾ At temperatures above 140°C, approximately 70 mins into cure, the increase in viscosity due to chemical reaction exceeds any reduction in viscosity resulting from the increasing temperature, consequently the loss factor begins to decline. The final cure temperature of 180°C is reached after 90 mins of beginning the experiment and the cure is essentially over in 120 mins. The permittivity data also shows that the end-of-cure occurs at about 120 mins. At 180°C the 1 Hz permittivity and loss factor are both off scale due to the very lossy nature of the resin. This indicates that to fully utilize the low frequency capability of the instrumentations, its range will have to be increased at least by a decade or two.

Cure of Aromatic Amine-Epoxy Resin

In this study a Shell epoxy resin, Epon 828, was cured with an aromatic amine curative, 4,4'-diaminodiphenyl sulfone (DDS), obtained from Ciba-Geigy Corp. as HT-976. 100 pbw of the resin was heated to 130°C to which was added 34 pbw of the powder DDS, which is the stoichiometric amount. The DDS was dissolved by stirring, whereupon the mixture was cooled for use.

A drop of the reactive mixture was placed on the sensor surface and the sensor was placed in a programmed oven to monitor the cure of the resin mix. The oven was programmed for a typical cure cycle used with DDS. The oven was heated at 2°C/min to 135°C where it was held for 1 hr, then heated at 2°C/min to 180°C, the final cure temperature. Figure 7 shows the permittivity data and Figure 8 shows the loss factor data. The temperature profile is also shown on both figures.

As the resin is heated the loss factor goes through a maximum upon reaching the hold temperature of 135°C. At this stage the loss factor is dominated by conductivity of the resin as can be seen from the inverse relationship of loss factor with the frequency of measurement. As discussed earlier, in this regime of cure, the permittivity at lower frequencies is very high due to the blocking electrodes which result in charge pile-up at the resin electrode interface. As the cure proceeds and the temperature is increased to the final cure temperature of 180°C, the loss factor values begin to diminish very rapidly again following an inverse frequency relationship. This initial drop in the loss factor is due to the reduction in viscosity with the onset of gelation which results in a reduction in the conductivity of the resin.⁽⁹⁾ As the conductivity decreases, the blocking electrode effect diminishes and the permittivity values at lower frequencies come on-scale and decrease rapidly.

From about 150 mins to 300 mins into the experiment (i.e., from onset of reaching 180°C to 150 mins at 180°C) Figures 7 and 8 show a classic dipolar relaxation. This occurs in the regime of cure characterized by resin vitrification and results in permittivities reducing from a high value

to a lower value with the permittivity at the highest observed frequency decreasing first. The loss factor in this regime of cure displays a series of dipole relaxation peaks with again the highest observed frequency being the first to go through a maximum. In this dispersion region it is interesting to note that the maximum in loss factor at any frequency occurs at the same time as the permittivity has undergone half of its reduction. This is characteristic of a classic Debye dipolar relaxation process. The 1 Hz data does not show a well defined relaxation peak possibly because the conductivity is high enough to mask it.

The sensitivity of the instrumentation at low loss factors (i.e., loss factors $<.1$) is limited principally by the gain-phase meter. It is difficult to identify the end-of-cure but it is apparent from the 1 Hz data that most of the reaction is over after 4 hrs at 180°C. However, a low level of cure may continue beyond this point. Currently a Fourier Transform Analyzer is being developed to replace the gain-phase meter to improve signal-to-noise ratios at low loss factors. To examine the progress of cure, FTIR and DSC measurements were made on castings of resin that were subjected to an identical cure cycle but were withdrawn at different periods of time from the programmed oven. Table 2 presents this data. The Tg was measured by DSC. FTIR absorbances for the epoxide group (915 cm^{-1}) and for the N-H stretch of aromatic primary amine (3370 cm^{-1}) were normalized using the constant $-\text{CH}_2$ stretch (2860 cm^{-1}) of the non-reacting $-\text{CH}_3$ group of bisphenol A. The ratio absorbance for $-\text{NH}$ has been corrected for the appearance of the $-\text{OH}$ band. The data of Table 2 shows that the reaction proceeds only after the temperature of 135°C is reached. There is a slow reaction at 135°C which accounts for

about 20% of the epoxide group conversion. On heat-up to 180°C, 62% of the epoxy group has been consumed. At the end of 4 hrs at 180°C, almost all (95%) of the initial epoxy has been reacted. This parallels closely the changes in the loss factor as shown in Figure 8 with the loss factor data giving much stronger information about gelation and vitrification process. After 4 hrs at 180°C the IR and DSC data confirm the microdielectrometry data that most of the reaction (but not necessarily all) is over.

CONCLUSIONS

Microdielectrometry can be successfully used to follow the cure of epoxy resins and prepregs. The loss factor data obtained can be used to define the regions of cure in which viscosity changes are taking place due to temperature changes and/or the gelation process. Vitrification of the resin can also be observed in the loss factor-permittivity data. The dielectric data correlates well with differential scanning calorimetry data and infrared analysis data.

Since electrode spacing during press or autoclave curing does not change in microdielectrometry, it is possible to reduce the dielectric data to permittivity and loss factor. In parallel plate dielectric measurements of cure one has to use dissipation factor to monitor cure because it is space independent. But since dissipation factor is a ratio of loss factor to permittivity and permittivity is affected by the blocking electrode effects discussed in the report, dissipation factor measurement during cure is also affected. Loss factor measurement, however, is a straightforward measure

of resin and prepreg cure and is able to monitor all phases of resin cure from melt and flow to gelation and subsequent vitrification.

ACKNOWLEDGMENT

The assistance of MIT in providing the sensor chips and the advice of Prof. S. Senturia of MIT are gratefully acknowledged. The FTIR work of J. R. Ray of Westinghouse R&D Center is gratefully acknowledged.

REFERENCES

- (1) C. A. May, Proc. SAMPE Symp., 20, 108 (1975).
- (2) B. G. Martin, Mater. Eval., 34, 49 (1976).
- (3) Z. N. Sanjana and R. L. Selby, IEEE Trans. on Elect. Insul., EI-16, 496 (1981).
- (4) J. Chottiner, Z. N. Sanjana, M. Kodani, K. W. Lengel and G. B. Rosenblatt, Polym. Composites, 3, n. 2, 59 (1982).
- (5) Z. N. Sanjana and J. R. Ray, ACS Div. of Polym. Chem., Polym. Prepr. 22, 255 (1981).
- (6) N. F. Sheppard, D. R. Day, H. L. Lee and S. D. Senturia, Sensors and Actuators, 2, 263 (1982).
- (7) N. F. Sheppard, S. L. Gaverich, D. R. Day and S. D. Senturia, Proc. SAMPE Symp., 26, 65 (1980).
- (8) Micromet Instruments, Inc., 37 Hurley St., Cambridge, MA 02141.

(9) S. D. Senturia, N. F. Sheppard, H. L. Lee and S. B. Marshall,
SAMPE Jnl., 19, n. 4, 22 (1983).

(10) Z. N. Sanjana and R. L. Selby, SAMPE Symp., 29, 1233 (1984).

TABLE 1

DSC AND FTIR DATA ON DICYANDIAMIDE CURED EPOXY RESIN

Cure Time @ 160°C	Tg* (°C)	Residual Exotherm (Cals/gm)	Ratio Absorbance	
			<u>915</u> <u>830</u>	<u>2200 + 2160</u> <u>830</u>
0	54.8	32.0	.117	.38
5	66.3	12.2	--	--
10	77.3	8.1	.061	.30
30	92.1	3.5	.037	.21
50	98.8	--	.024	.18
70	101.2	--	.022	.15
90	102.8	--	.022	.14

*Onset temperature - start of endotherm.

TABLE 2

DSC AND FTIR DATA ON DIAMINODIPHENYL SULFONE CURED EPOXY RESIN

Sample No.	Time of Removal of Casting	Tg* (°C)	Ratio Absorbance	
			$\frac{915}{2860}$	$\frac{3370}{2860}$
A	Heat to 135°C	--	.642	1.110
B	A + 15 mins @ 135°C	--	.640	1.210
C	A + 1 hr @ 135°C	68.7	.509	.859
D	C + Heat to 180°C	130.1	.243	.293
E	D + 1 hr @ 180°C	166.8	.086	.103
F	D + 2 hrs @ 180°C	181.6	.050	.060
G	D + 4 hrs @ 180°C	196.6	.032	.050

*Onset temperature - start of endotherm.

Dwg. 936 2A33

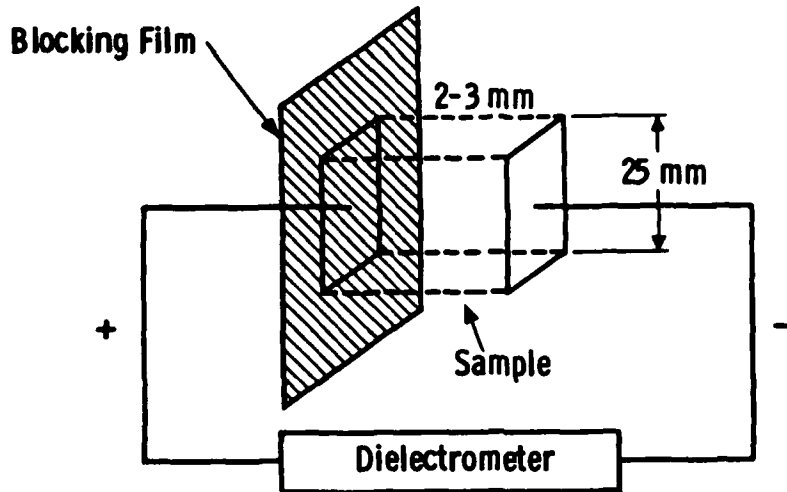

PARRALLEL PLATE DIELECTROMETRY

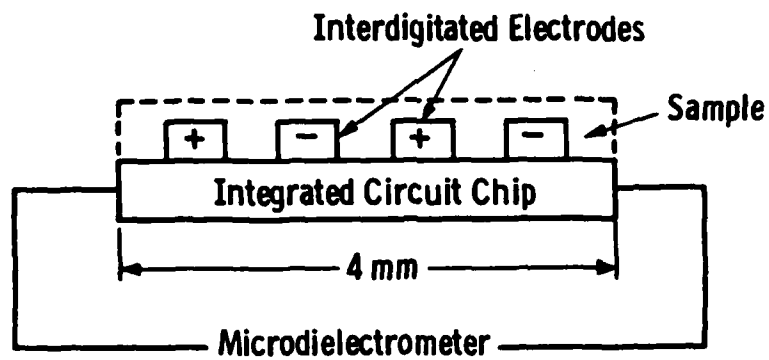

MICRODIELECTROMETRY

Fig. 1—Schematic differences between conventional dielectrometry and microdielectrometry. Not drawn to scale

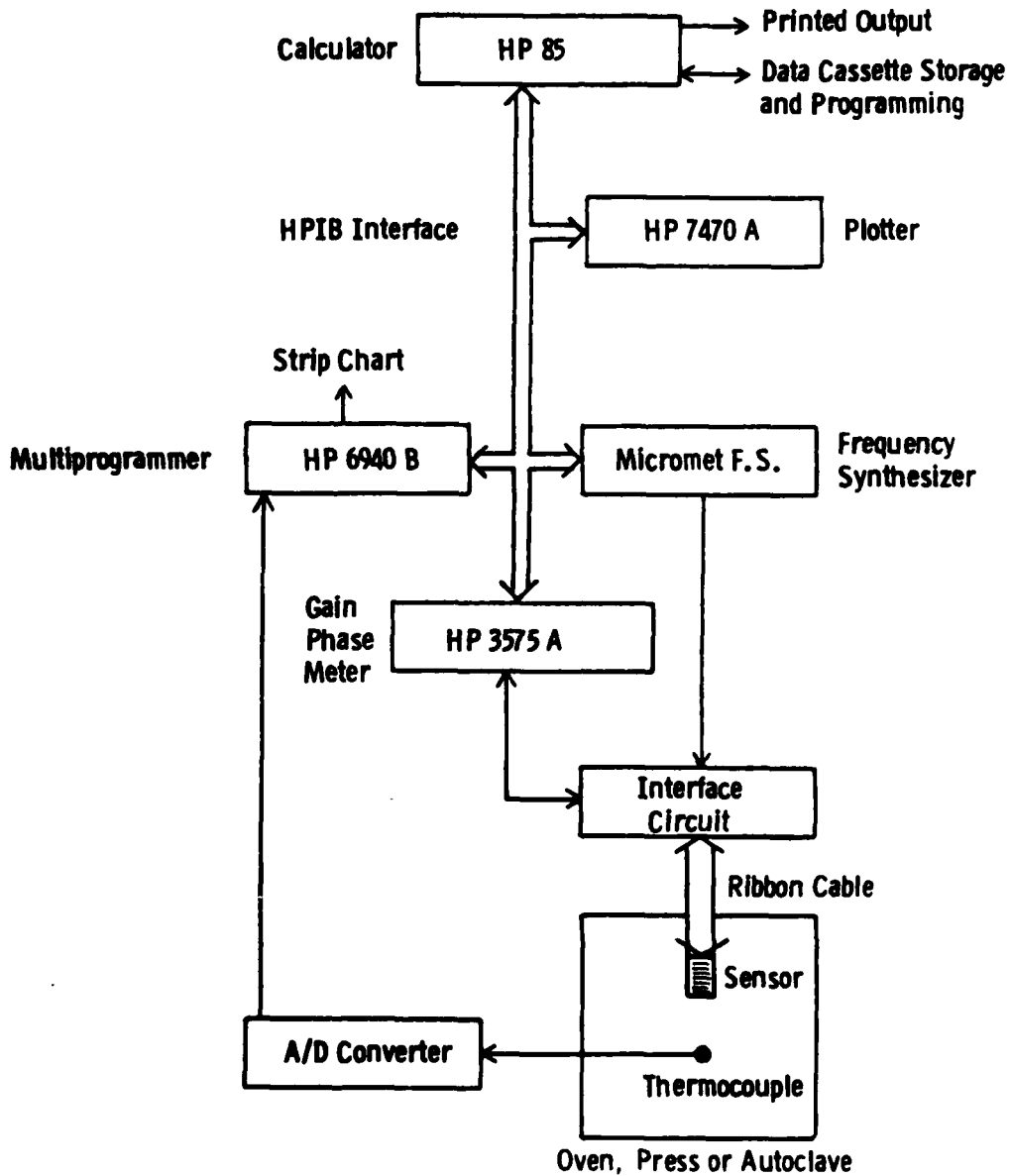

Fig. 2 - Block diagram of measuring system for microdielectrometry

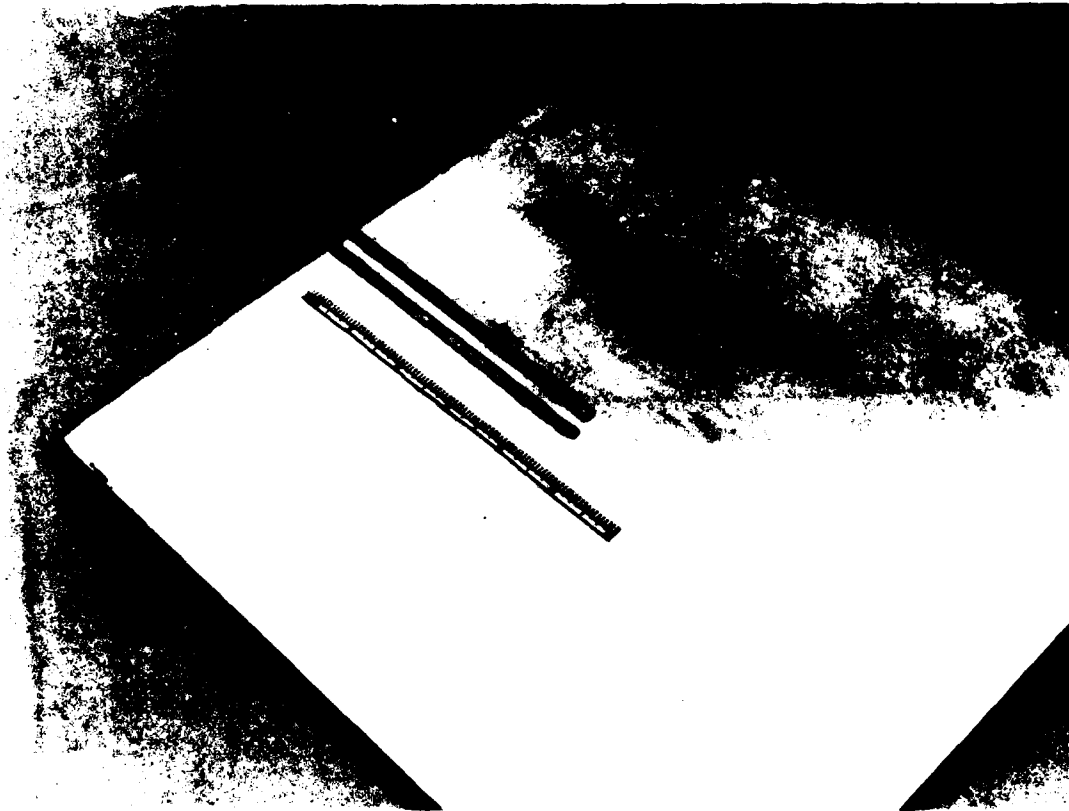

Fig. 3 - Sensor packaged in a flat ribbon connector.
Channel cut in caul plate to accommodate sensor
cable for monitoring laminate cure.

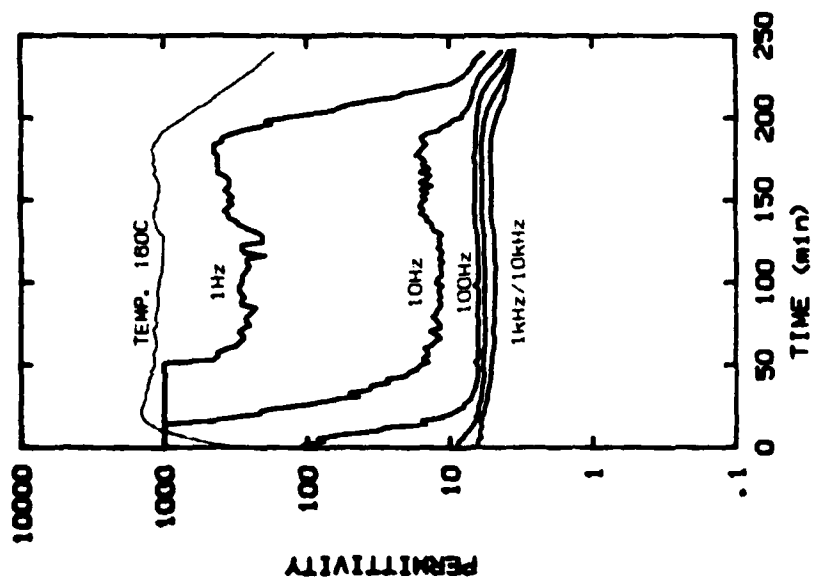
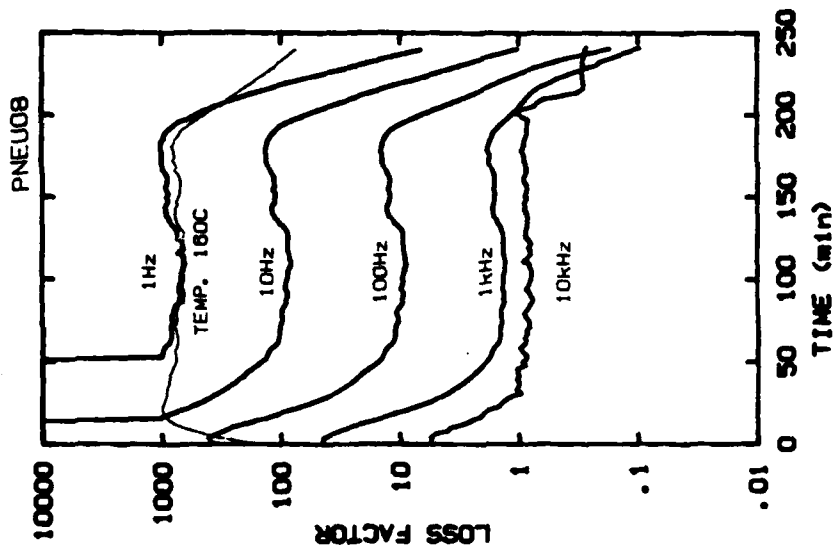

FIG. 4 ISOTHERMAL CURE OF EPOXY PREPREG
AT A TEMPERATURE OF 160C

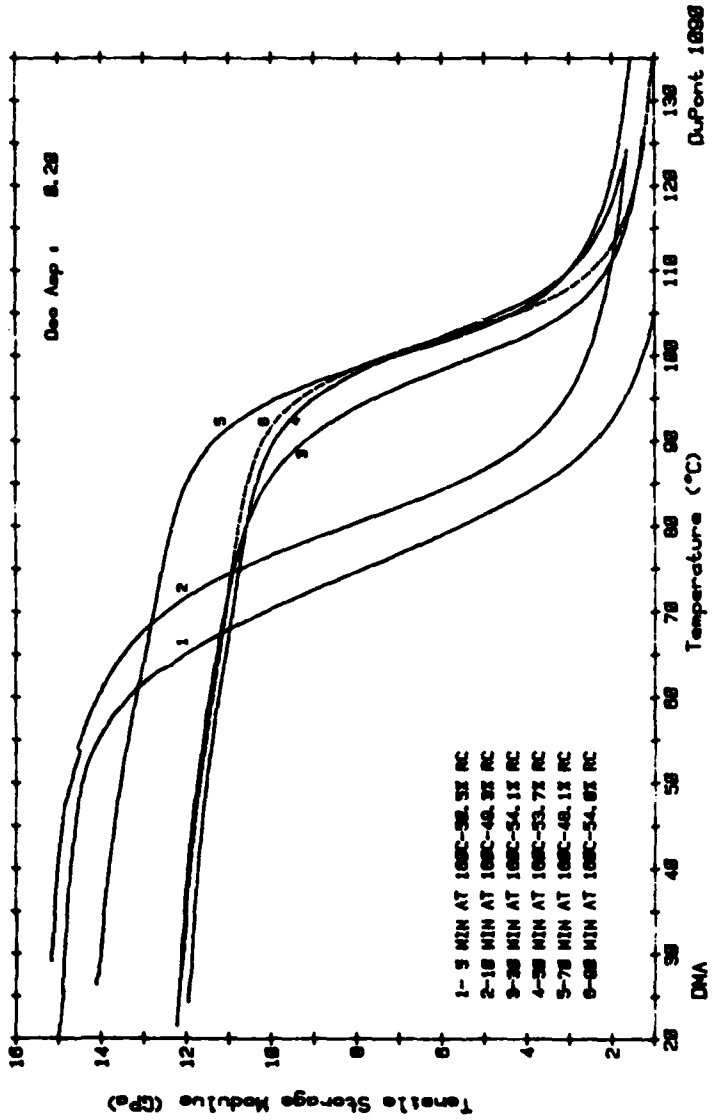

FIG. 5 DYNAMIC MECHANICAL ANALYSIS OF CURE OF EPOXY PREPREG.

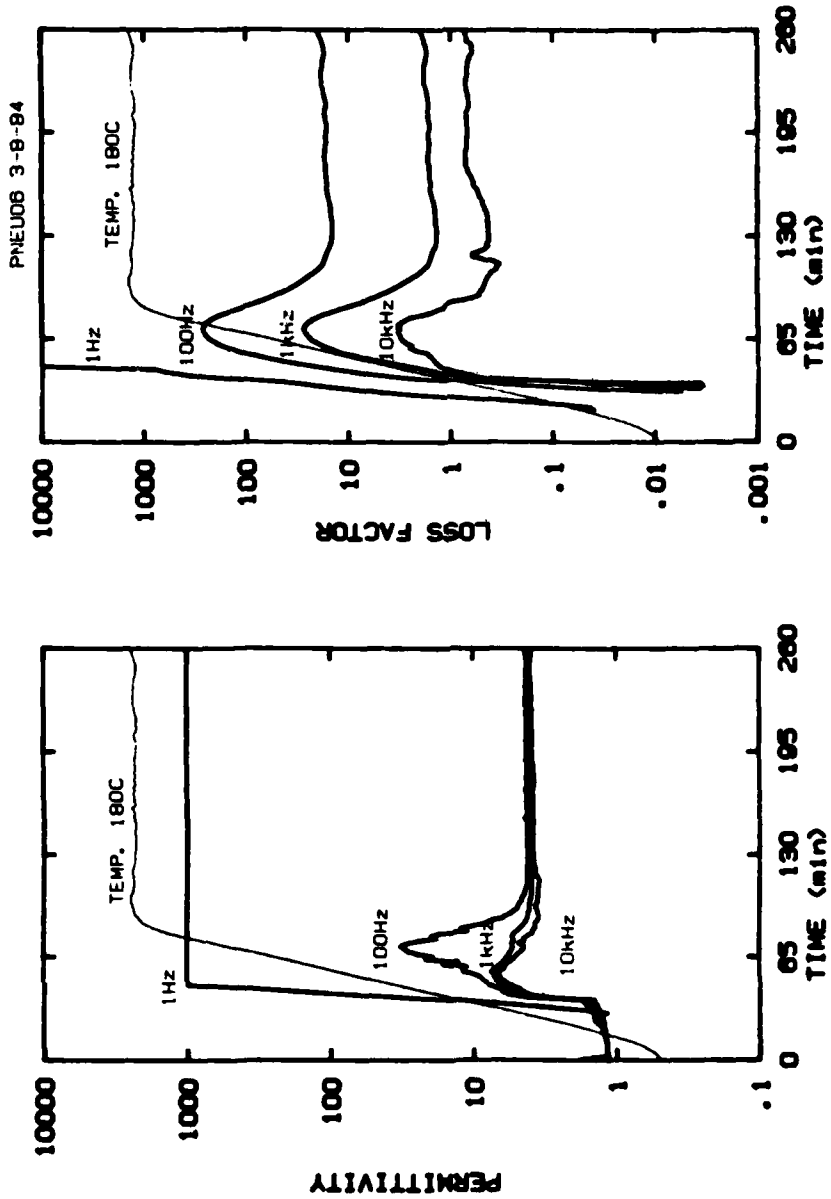

FIG. 6 CURE OF EPOXY PREPREG IN A PRESS

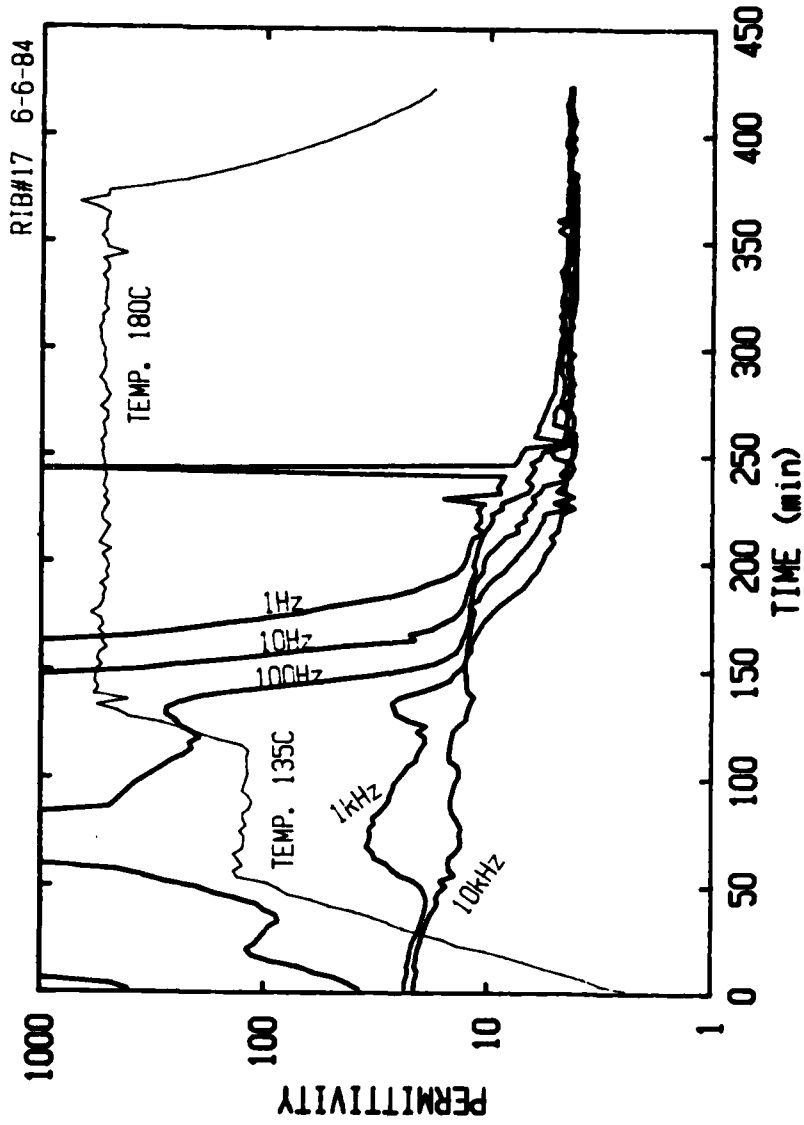

FIG. 7 CURE OF EPOXY-AROMATIC AMINE RESIN.

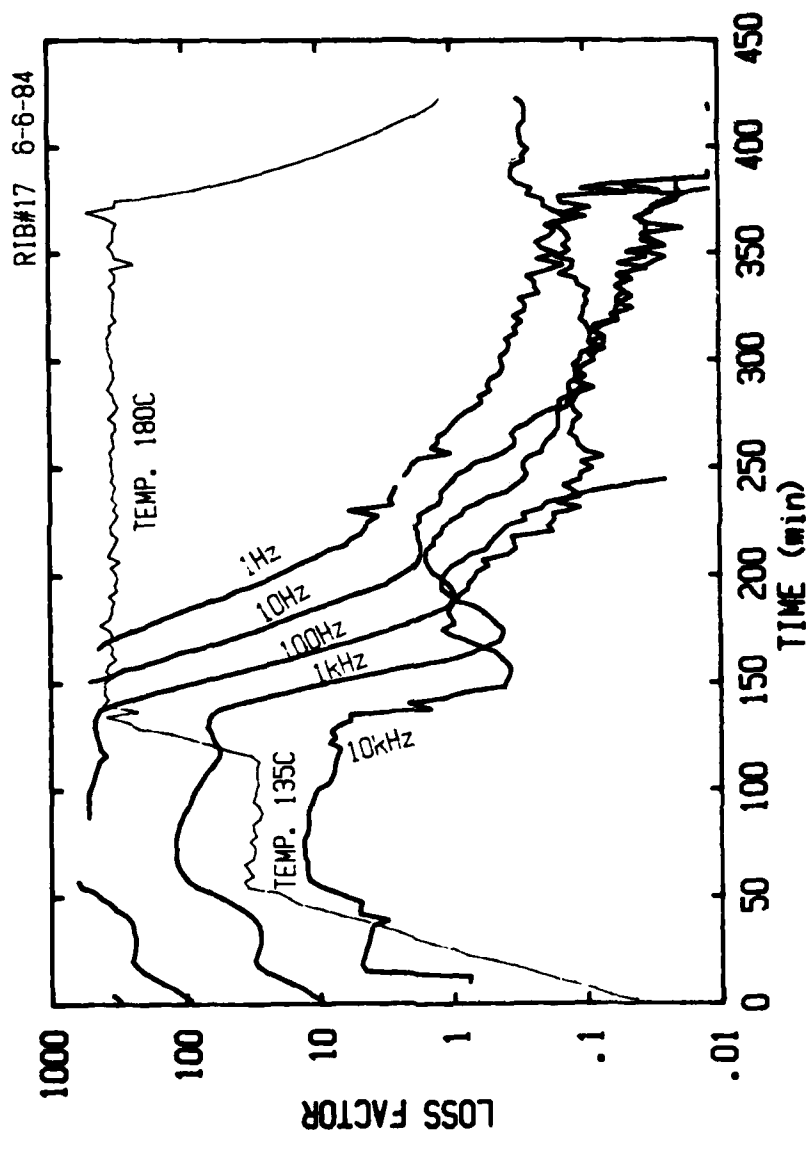

FIG.8 CURE OF EPOXY-AROMATIC AMINE RESIN

Adhesion 1

DISTRIBUTION LIST

Dr. J. M. Augl
Naval Surface Weapon Center
White Oak, MD 20910

Prof. F. J. Boerio
Dept of Materials Science
U. of Cincinnati
Cincinnati, OH 45221

Prof. H. F. Brinson
Center for Adhesion Science
VPI&SU
Blacksburg, VA 24061

Dr. M. Broadhurst
National Bureau of Standards
Gaithersburg, MD 20899

Dr. Charles Browning
AFWAL/ML
WPAFB, OH 45433

Dr. Stan Brown
NADC
Warminster, PA

Defense Technical Information Center
Cameron Station
Alexandria, VA 22314
(12 Copies)

Dr. Dawn Dominguez
Naval Research Laboratory
Washington, D.C. 20375

Dr. L. T. Drzal
AFWAL/MLBM
WPAFB, OH 45433

Prof. D. W. Dwight
Center for Adhesion Science
VPI&SU
Blacksburg, VA 24061

Dr. Alan Gent
Institute of Polymer Science
University of Akron
Akron, OH 44304

Prof. Brian Hornbeck
U. S. Army R&D Center
STRBF-NBC
Ft. Belvoir, VA 22060

Dr. Don Hunston
Polymer Division
National Bureau of Standards
Gaithersburg, MD 20899

Prof. Wolfgang Knauss
Graduate Aeronautical Labs
California Technical
Pasadena, CA 91125

Dr. W. B. Moniz
Naval Research Laboratory
NODE 6120
Washington, DC 20375

Dr. L. H. Peebles, Jr. (4 copies)
Office of Naval Research
Code 431
800 N. Quincy St.
Arlington, VA 22217-5000

Dr. R. R. Reeber
ARO
PO Box 12211
Research Triangle Park, NC 27709

Mr. Z. Sanjana
Westinghouse R&D Center
Pittsburgh, PA 15235

Prof. S. N. Senturia
MIT
Rm 13-3010
Cambridge, MA 02139

Dr. Robert Timme
NRL/USRD
Orlando, FL 32806

Dr. Ting
NRL/USRD
Orlando, FL 32806

Dr. Ron Trabocco
Code 60631
NADC
Warminster, PA

DISTRIBUTION LIST

Dr. J. D. Venables
Martin Marrietta Labs
Dept. of Chemical Engineering
Princeton University, Wentworth
Princeton, NJ 08540

Prof. T. C. Ward
Center for Adhesion Science
VPI&SU
Blacksburg, VA 24061

Dr. S. Wentworth
AMXMR-OP AMMRC
Watertown, MA 02172

Prof. J. P. Wightman
Center for Adhesion Science
VPI&SU
Blacksburg, VA 24061

Dr. Henry Wohltjen
Naval Research Laboratory
Code 6100
Washington, D.C. 20375

Dr. K. J. Wynne
Office of Naval Research
Code 413
800 N. Quincy St.
Arlington, VA 22217-5000

Mr. M. Mitchell
Naval Air Systems Command
Code AIR 5304C2
Washington, D.C. 20361
(6 Copies)

Dr. W. O. Feldmeier
Materials & Process Div.
McDonnell Aircraft Co.
P.O. Box 516
St. Louis, MO 63166

Dr. C. F. Poranski
Chemistry Div.
Code 6120
Naval Research Lab
Washington, D.C. 20375

Dr. F. J. Campbell
Cond. Matter & Rad. Sci. Div.
Code 6654
Naval Research Lab
Washington, D.C. 20375

Dr. B. E. Goldberg
George C. Marshall Space
Flight Center
Alabama 35812

Lockheed-Georgia Company
Engineering Information Center
Dept. 73-34, Zone 415
Marietta, GA 30063

END

FILMED

1-85

DTIC