

MICROCOPY RESOLUTION TEST CHART
NATIONAL BUREAU OF STANDARDS 1963 A

12

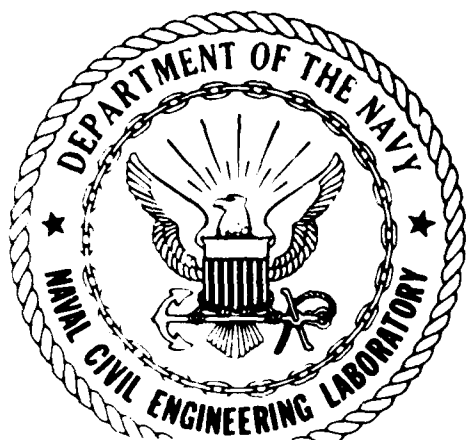

CR 85.003

NAVAL CIVIL ENGINEERING LABORATORY
Port Huene, California

AD-A147 662

Sponsored by
NAVAL FACILITIES ENGINEERING COMMAND

RDF UTILIZATION IN A NAVY
STOKER COAL-FIRED BOILER

October 1984

An investigation conducted by
VSE Corporation
1200 Paseo Camarillo
Camarillo, CA 93010-6093

N00123-82-D-0149

Approved for public release, distribution is unlimited

OTIC FILE COPY

METRIC CONVERSION FACTORS

| Approximate Conversions to Metric Measures | | | | Approximate Conversions from Metric Measures | | | |
|--|------------------------|------------------------|---------------------|--|-----------------------------------|-------------------|------------------------|
| Symbol | When You Know | Multiply by | To Find | Symbol | When You Know | Multiply by | To Find |
| in | inches | 2.5 | centimeters | cm | centimeters | 0.04 | inches |
| ft | feet | 30 | centimeters | cm | inches | 0.4 | inches |
| yd | yards | 0.9 | meters | m | feet | 3.3 | feet |
| m | miles | 1.6 | kilometers | km | yards | 1.1 | yards |
| | | | | | miles | 0.6 | miles |
| in ² | square inches | 6.5 | square centimeters | cm ² | square centimeters | 0.16 | square inches |
| ft ² | square feet | 0.09 | square meters | m ² | square meters | 1.2 | square yards |
| yd ² | square yards | 0.8 | square meters | m ² | square kilometers | 0.4 | square miles |
| mi ² | square miles | 2.6 | square kilometers | km ² | hectares (10,000 m ²) | 2.5 | acres |
| | acres | 0.4 | hectares | ha | | | |
| oz | ounces | 28 | grams | g | grams | 0.035 | ounces |
| lb | pounds | 0.45 | kilograms | kg | kilograms | 2.2 | pounds |
| | short tons | 0.9 | metric tons | t | metric tons (1,000 kg) | 1.1 | short tons |
| | (2,000 lb) | | | | | | |
| tsp | teaspoons | 5 | milliliters | ml | milliliters | 0.03 | fluid ounces |
| Tbsp | tablespoons | 15 | milliliters | ml | liters | 2.1 | pints |
| fl oz | fluid ounces | 30 | milliliters | ml | liters | 1.06 | quarts |
| c | cups | 0.24 | liters | l | liters | 0.26 | gallons |
| pt | pints | 0.47 | liters | l | cubic meters | 35 | cubic feet |
| qt | quarts | 0.95 | liters | l | cubic meters | 1.3 | cubic yards |
| gal | gallons | 3.8 | liters | l | | | |
| ft ³ | cubic feet | 0.03 | cubic meters | m ³ | | | |
| yd ³ | cubic yards | 0.76 | cubic meters | m ³ | | | |
| °F | Fahrenheit temperature | 5/9 (then subtract 32) | Celsius temperature | °C | Celsius temperature | 9/5 (then add 32) | Fahrenheit temperature |

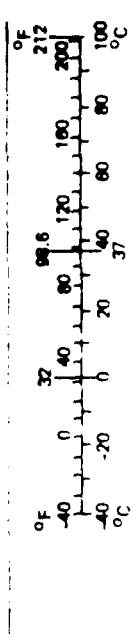
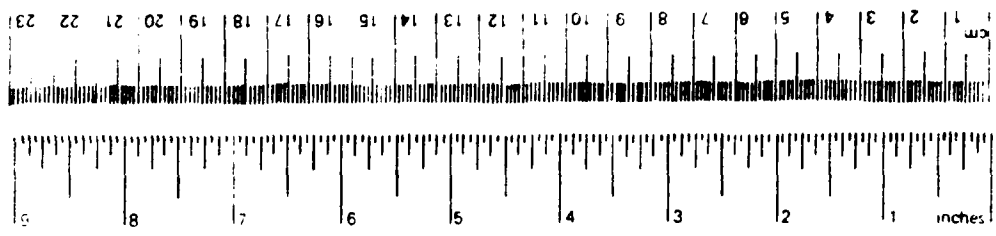

* For 2.54 exactly. For other weight conversions and more detailed tables, see NBS Misc. Publ. 286, *Tables of Weights and Measures*, U.S. Dept. of Commerce, NBS, Gaithersburg, MD, 20899.

Unclassified

SECURITY CLASSIFICATION OF THIS PAGE (When Data Entered)

| REPORT DOCUMENTATION PAGE | | READ INSTRUCTIONS BEFORE COMPLETING FORM |
|---|------------------------------------|---|
| 1 REPORT NUMBER CR 85.003 | 2 GOVT ACCESSION NO. D 14787-66 | 3 RECIPIENT'S CATALOG NUMBER |
| 4 TITLE (and Subtitle) RDF Utilization in a Navy Stoker Coal-Fired Boiler | | 5 TYPE OF REPORT & PERIOD COVERED Final Sep 1982 - Sep 1984 |
| 7 AUTHOR George Gardiner Anil Chatterjee | | 6 PERFORMING ORG. REPORT NUMBER |
| 9 PERFORMING ORGANIZATION NAME AND ADDRESS VSE Corporation 1200 Paseo Camarillo Camarillo, CA 93010-6093 | | 8 CONTRACT OR GRANT NUMBER N00123-82-D-0149 |
| 11 CONTROLLING OFFICE NAME AND ADDRESS Naval Civil Engineering Laboratory Port Hueneme, CA 93043 | | 10 PROGRAM ELEMENT PROJECT TASK AREA & WORK UNIT NUMBERS Y0817-006-01-213 |
| 14 MONITORING AGENCY NAME & ADDRESS (if different from Controlling Office) Naval Facilities Engineering Command 200 Stovall Street Alexandria, VA 22332 | | 12 REPORT DATE October 1984 |
| 16 DISTRIBUTION STATEMENT (of this Report) Approved for public release; distribution is unlimited. | | 13 NUMBER OF PAGES 167 |
| 17 DISTRIBUTION STATEMENT (of the abstract entered in Block 20, if different from Report) | | 15 SECURITY CLASS. of this report Unclassified |
| 18 SUPPLEMENTARY NOTES | | 15a DECLASSIFICATION/DOWNGRADING SCHEDULE |
| 19 KEY WORDS (Continue on reverse side if necessary and identify by block number) RDF, stoker coal-RDF, solid waste, RDF economics, energy recovery | | |
| 20 ABSTRACT (Continue on reverse side if necessary and identify by block number) This report addresses the economics of co-firing refuse derived fuel (RDF) in a stoker coal fired boiler. The report identifies the type of RDF required, the cost and type of modification to the coal boiler, and the price which can be paid for RDF based on boiler size and RDF feedrate. Life cycle economic procedures are used to develop break-even graphs of RDF price | | |

DD FORM 1473 EDITION OF 1973

Unclassified
SECURITY CLASSIFICATION OF THIS PAGE (When Data Entered)

EXECUTIVE SUMMARY

Refuse Derived Fuel (RDF) is a technically sound alternative to fossil fuels for use in Navy coal-fired boiler plants. The Navy currently has 37 major boilers in operation that would be possible candidates for conversion to co-fired facilities. These boilers are outfitted with the required coal storage and delivery systems and appropriate air pollution control equipment.

Although complete replacement of coal with RDF may be desirable, these existing Navy boilers are inadequately designed to fire 100% RDF. The principal problems are inadequate combustion chamber size, inadequate tube spacing, lack of an ash handling system, poor combustion, changes in air and flue gas flow, and excessive slagging. As a result, it is recommended that the use of RDF be limited to a maximum of 50% of the energy production in any coal-fired boiler conversion consideration.

The selection of the actual RDF to be used in a converted boiler should be based upon the most practical and economical fuel mix. RDF-3 has a high degree of refinement and is best suited for use with pulverized coal where increased suspension burning is required. RDF-2 is a coarser material that is more appropriate for use in a stoker-fired boiler. Thus, this study is based on the use of RDF-2 as a supplemental fuel.

The report presents a conceptual design of the systems for producing and delivering the RDF-2 to a Navy stoker coal-fired boiler, and the modification needed to retrofit the boiler to a co-fired operation. Specific items of equipment are recommended where appropriate. This conceptual design is based on the experiences of other facilities around the country supplemented with information obtained from data in the literature, phone calls, and site visits.

In order to provide site specific recommendations, an evaluation was made of the Navy inventory of industrial boilers by gathering information from the Navy Energy and Environmental Support Activity, engineering field divisions, and field activities.

Currently the Navy has 27 industrial size boilers firing coal as a primary fuel and 10 firing coal as a secondary fuel. The four principal factors influencing any decision to convert boiler facilities are:

- Age of plant facilities.
- Station demand load for steam.
- The relationship between the cost of coal and the cost of RDF in terms of dollars per MBtu.
- The need to hold dedicated fossil fuel-fired boilers in reserve.

Reviewing the inventory of boilers, 23 (or 62%) are over age and 4 (or 11%) would be required to be held in dedicated fossil fuel-fired standby status.

Life-cycle studies were conducted in five hypothetical 20-year operating situations involving plant capacities ranging from 100 MBtu per hour (two 50 MBtu per hour boilers) to 450 MBtu per hour (three 150 MBtu per hour boilers), and assuming RDF is purchased from a commercial facility.

In addition, two detailed life-cycle case studies were conducted based on the installation of a contractor owned and operated MSW processing plant being located within 1/2 mile of the Navy boiler plant. In summary using either approach, the maximum cost the Navy could pay for RDF is approximately \$13 per ton if the original capital investment costs are to be recovered.

The 10 boilers determined to have the operating characteristics to make them technically sound were then evaluated for economic merit. None of the 10 boilers evaluated were recommended for conversion. The two principal reasons are:

- The cost of coal and the cost of RDF per MBtu are too close; i.e., coal at \$42 per ton = \$1.68 per MBtu, and RDF at \$20 per ton = \$1.52 per MBtu.
- The overall station demand load for steam is inadequate to generate the fuel cost savings to offset the capital investment costs. Boilers would operate anywhere between 40% and 90% of capacity, vice the 90% required to support the savings shown in the analyses.

The general conclusions address the Navy's need to plan an energy efficient replacement program for the aging inventory of boilers, vice conversion of existing assets.

As an alternative to conversion of existing assets, it is recommended that future RDF considerations be aligned towards analyzing the replacement of overaged facilities with either mass burning solid waste plants or refuse derived fuel-fired plants, in lieu of conversion.

TABLE OF CONTENTS

| Section | Page |
|--|------|
| 1.0 INTRODUCTION..... | 1 |
| 2.0 OBJECTIVE AND SCOPE OF WORK..... | 2 |
| 3.0 BACKGROUND..... | 3 |
| 3.1 General..... | 3 |
| 3.2 Fuel Preparation..... | 5 |
| 3.2.1 Solid Waste Generation..... | 5 |
| 3.2.2 Raw Waste Transport..... | 6 |
| 3.2.3 Raw Waste Processing..... | 6 |
| 3.3 Fuel Utilization..... | 7 |
| 3.3.1 Prepared Fuel Transport To Storage..... | 7 |
| 3.3.2 Solid Fuel Storage..... | 7 |
| 3.3.3 Transportation of Stored RDF to Boiler..... | 7 |
| 3.3.4 Steam Generation..... | 9 |
| 3.3.5 Control of Combustion Residuals..... | 9 |
| 3.4 Summary..... | 10 |
| 4.0 TECHNICAL CONSIDERATIONS..... | 11 |
| 4.1 Preparation of MSW as RDF..... | 11 |
| 4.1.1 Fuel Specification..... | 14 |
| 4.1.1.1 Existing Usage of RDF..... | 14 |
| 4.1.1.2 RDF Design..... | 20 |
| 4.1.2 Processing Subsystem..... | 21 |
| 4.1.3 Transport and Delivery Subsystems..... | 26 |
| 4.1.4 Storage and Retrieval of RDF..... | 28 |
| 4.2 Combustion Subsystems..... | 29 |
| 5.0 FIELD SURVEY DATA..... | 32 |
| 6.0 ECONOMIC EVALUATION..... | 32 |
| 6.1 General..... | 32 |
| 6.2 MSW Processing Plant..... | 34 |
| 6.3 Economic Model..... | 34 |
| 6.4 Annual Fuel Cost Savings..... | 35 |
| 6.5 Design of Retrofitted Facilities..... | 36 |
| 6.6 Capital Investment Costs..... | 36 |
| 6.7 O&M Costs..... | 36 |
| 6.8 Annual O&M and Capital Recovery Cost Factors..... | 36 |
| 6.9 Break-even Point..... | 38 |
| 6.10 Case Studies..... | 39 |
| 6.11 Savings-to-Investment Ratio and Discount Payback Periods..... | 41 |
| 6.12 Site Specific Reviews..... | 41 |
| 6.13 Critical Cost Parameters..... | 42 |
| 7.0 NAVY BOILER PLANTS..... | 44 |
| 7.1 Coal-Fired Boilers..... | 44 |
| 7.1.1 General..... | 44 |
| 7.1.2 Coal as a Primary Fuel..... | 45 |
| 7.1.3 Coal as a Secondary Fuel..... | 45 |

TABLE OF CONTENTS (Continued)

| Section | Page |
|---|------|
| 7.2 Technical Evaluation..... | 46 |
| 7.3 Economic Evaluation..... | 47 |
| 8.0 CONCLUSIONS, AND RECOMMENDATIONS..... | 47 |
| 8.1 General..... | 47 |
| 8.2 Conclusions..... | 49 |
| 8.3 Recommendations..... | 50 |
| REFERENCES..... | 51 |
| APPENDIX A DESIGN PARAMETERS..... | A-1 |
| APPENDIX B FIELD SURVEY DATA..... | B-1 |
| APPENDIX C ECONOMIC ANALYSIS..... | C-1 |

LIST OF ILLUSTRATIONS

| Figure | Title | Page |
|--------|--|------|
| 3-1 | Raw Refuse Processing, Transport, and Retrieval Schemes..... | 8 |
| 4-1 | Material and Energy Balance for a Resource Recovery Plant..... | 12 |
| 4-2 | Daily RDF Moisture and Heating Values at Ames Municipal Power Plant - 1976..... | 16 |
| 4-3 | Monthly Average RDF Moisture and Heating Values at Ames Municipal Power Plant - 1976..... | 17 |
| 4-4 | Flow Diagram of an MSW Processing Plant to Produce RDF-2 Fuel.. | 24 |
| 4-5 | Proposed Pneumatic Transport of RDF and Boiler Firing Scheme... | 28 |
| A-1 | Flow Diagram of an MSW Processing Plant to Produce RDF-2 Fuel.. | A-2 |
| A-2 | Trommel Screen..... | A-5 |
| A-3 | Overhead Belt Magnetic Separators..... | A-10 |
| A-4 | Magnetic Pulley Separator..... | A-11 |
| A-5 | Dual Drum Magnetic Separator..... | A-11 |
| A-6 | Zig-Zag Air Classifier..... | A-15 |
| A-7 | Horizontal Air Classifier..... | A-16 |
| A-8 | Vertical Air Classifier..... | A-16 |
| A-9 | Vertical Air Classifier (Triple/S)..... | A-17 |
| A-10 | Impulse Air Classifier..... | A-17 |
| A-11 | Rotary Drum Air Classifier..... | A-18 |
| A-12 | Inside View of Doffings Roll Bin..... | A-20 |
| A-13 | Cutter Assembly on a Saturn Shredder..... | A-24 |
| A-14 | Horsepower Required for Size Reduction of MSW as a Function of Feedrate and Desired Product Size..... | A-27 |
| A-15 | Grate Spacing Required to Produce a Desired Product Size..... | A-28 |
| A-16 | Typical Cross Sectional Designs of Belt Conveyors..... | A-31 |
| A-17 | MSW Enters Pan Conveyor System..... | A-33 |
| A-18 | Proposed Pneumatic Transport of RDF and Boiler Firing Scheme... | A-36 |
| A-19 | Atlas Storage and Reclaim System..... | A-43 |
| A-20 | Modified Traveling Grate Stoker Coal-Fired Boiler..... | A-47 |

TABLE OF CONTENTS (Continued)

LIST OF ILLUSTRATIONS (Continued)

| Figure | Title | Page |
|--------|---|------|
| A-21 | Overfire Air Jets..... | A-47 |
| A-22 | Overfire Air Application to Chain-grate Stoker..... | A-48 |
| A-23 | Riley Pneumatic Refuse Fuel Distributor..... | A-54 |
| B-1 | The Ames Recovery System..... | B-3 |
| C-1 | Comparison of Annual Fuel Cost Savings to O&M RDF and Capital Recovery Cost for a Boiler Capacity of 100 MBtu/hr.... | C-16 |
| C-2 | Comparison of Annual Fuel Cost Savings to O&M RDF and Recovery Cost for a Boiler Capacity of 150 MBtu/hr..... | C-17 |
| C-3 | Comparison of Annual Fuel Cost Savings to O&M RDF and Recovery Cost for a Boiler Capacity of 200 MBtu/hr..... | C-18 |
| C-4 | Comparison of Annual Fuel Cost Savings to O&M RDF and Recovery Cost for a Boiler Capacity of 300 MBtu/hr..... | C-19 |
| C-5 | Comparison of Annual Fuel Cost Savings to O&M RDF and Recovery Cost for a Boiler Capacity of 450 MBtu/hr..... | C-20 |

LIST OF TABLES

| Table | Title | Page |
|-------|--|------|
| 3-1 | Importance of Technical Issues in the Energy Recovery Process..... | 10 |
| 4-1 | Size Distribution of RDF Discharged from the Storage Bin..... | 15 |
| 4-2 | Comparison of Daily Samples of RDF Taken Over 1-Year Period.... | 18 |
| 4-3 | Bulk Density, and Proximate and Ultimate Analysis of RDF Discharged from the Storage Bin..... | 18 |
| 4-4 | Variability of Daily Values of Characteristics of RDF Dis- charged from Storage Bin..... | 19 |
| 4-5 | MSW Processing Train Capacities at Different RDF Inputs..... | 23 |
| 6-1 | Annual Fuel Cost Savings..... | 35 |
| 6-2 | Capital Investment Cost Summary Navy Boiler Plant Modifications..... | 37 |
| 6-3 | O&M Supplemental costs..... | 37 |
| 6-4 | Summary of Case Studies..... | 40 |
| A-1 | Trommel Fraction Composition..... | A-6 |
| A-2 | List of Types of Air Classifier Installations..... | A-14 |
| A-3 | Advantages and Disadvantages of Mechanical and Pneumatic Conveyor Systems..... | A-38 |
| A-4 | Design Conditions at Maximum Continuous Rating..... | A-57 |
| A-5 | City of Ames and G.M. Truck and Coach Manufacturing Plans Fuel Characteristics..... | A-58 |
| B-1 | Capitalization Ames Refuse Fuel Production Facilities..... | B-4 |
| B-2 | City of Ames, IA, Solid Waste Comparative Statement..... | B-5 |

LIST OF TABLES (Continued)

| Table | Title | Page |
|-------|---|------|
| B-3 | Ames Solid Waste Recovery System Materials, Revenues, and Expenses for Plant Operation..... | B-6 |
| B-4 | City of Ames Solid Waste Recovery System Data Report through Fourth Quarter..... | B-7 |
| C-1 | MSW Processing Plant Operations and Production Cost..... | C-4 |
| C-2 | Boiler Operation Summary..... | C-7 |
| C-3 | Annual Fuel Cost Savings..... | C-10 |
| C-4 | Capital Costs Summary..... | C-11 |
| C-5 | Capital Investment Cost Summary Navy Boiler Plant Modifications..... | C-13 |
| C-6 | O&M Supplemental Costs..... | C-13 |

1.0 INTRODUCTION

There are four major ways to recover energy from Municipal Solid Wastes (MSW):

- Burn MSW in a waterwall or refractory wall incinerator to produce steam.
- Process MSW into solid Refuse-Derived Fuel (RDF) and either co-fire RDF with a fossil fuel (preferably coal) or fire RDF in a dedicated RDF boiler to produce steam.
- Process MSW by pyrolysis to produce gas and oil and then burn the pyrolytic fuels to generate steam.
- Extract the methane-rich gas produced by the natural decomposition (anaerobic digestion) of MSW either in landfills or in digesters (chemical process plants).

In recent years, more and more waste-processing facilities have become interested in burning MSW in shredded form in modern spreader stoker coal-fired boilers. Burning the shredded MSW in the form of RDF in quantities up to 100% of a boiler's input is attractive for the following reasons:

- RDF burning is the most thermally efficient way to convert waste to energy products. The factors contributing to this high conversion efficiency are the ability of the boiler and its firing method to operate with low excess air and lower exit gas temperature than mass burning.
- RDF burning can be employed in steam plants by utilizing it in conjunction with the burning of solid fuels, such as coal, wood, bark, furfural, and bagasse.
- The total capital cost of retrofitting the boiler including stoker furnace, economizer, air preheater, and forced and induced draft fans should be less for a spreader stoker coal and RDF co-fired application than for construction of a mass-burning system.
- RDF fuel is more homogeneous than the mass-burned MSW fuel. As a result, a good mixing of fuel and air can be achieved and therefore better combustion efficiency can be maintained.
- By the process of converting MSW to RDF, valuable byproducts such as ferrous and nonferrous metals and glass can be salvaged.

Although there are many advantages, there are also disadvantages with the RDF-to-energy conversion scheme, including the following:

- An MSW-to-RDF processing plant will require complex, high capital intensive processing equipment. A sophisticated refuse processing and resource recovery plant will be costly to own, operate, and maintain. Most of the front-end processing equipment system was originally designed for processing homogeneous solids rather than the heterogeneous MSW. As a result, the reliability of equipment operation is low and maintenance problems are numerous.
- The capital, operating, and maintenance costs, including power consumption and utilities costs, will be higher than for a mass-burning system. For a retrofit system, maintenance costs may be quite high and reliability of operation may be low.
- In the preparation of RDF fuel, depending upon the refinement of the RDF that is made, significant loss of combustibles may result.
- Markets for byproducts are uncertain and prices vary widely.

In July 1976, the Navy issued a guideline entitled "Energy Source Selection and Criteria for Shore Facilities," in which the co-firing of RDF and coal in all new generating facilities over 50 million Btu/hr capacities was stressed. In conjunction with this guideline, the Naval Civil Engineering Laboratory was tasked to conduct technical, economic, and environmental evaluations for RDF utilization in Navy coal-fired boilers.

2.0 OBJECTIVE AND SCOPE OF WORK

The objective of this study is to evaluate the technical and economic considerations associated with of the concept of co-combustion of an appropriately prepared RDF fuel with coal in a retrofitted stoker coal-fired boiler.

The following assumptions establish the basis for the study:

- The stoker coal-fired boiler rating used to establish the parameters for the MSW processing plant will be 150 MBtu/hr. Boiler plant capacities of 300 MBtu/hr and 450 MBtu/hr will be used to economically evaluate the options.
- A selection of RDF quality, with appropriate justification, will be included as an integral part of the study. The RDF is of either of the two following types:

- RDF-2: waste processed to coarse particle size, with or without ferrous metal separation.
- RDF-3: waste processed to remove metal, glass, and other inorganics; 95% by weight passes through a 2-inch square mesh screen.
- The physical and chemical properties of the RDF to be used are as follows:
 - Heating Value (dry basis) = 7500 Btu/lb.
 - Moisture Content (as-fired basis) = 20%.
 - Ash Content (as-fired basis) = 15%.
- The feedstock RDF is procured from a local MSW processing center and delivered to the storage facility at the Navy steam plant.
- The evaluations are based on the use of RDF as supplementary fuel to coal in varying proportions, or as 100% RDF.
- The evaluations are based on published data from similar RDF and coal co-combustion facilities supplemented by plant visits and direct contacts with similar supplementary fuel-firing plants.

The scope of the work includes the following:

- Address the concept as a total system and also as a series of five subsystems; i.e., processing, transportation, storage, delivery, and combustion.
- Identify major characteristics of the subsystems.
- Provide rationale supporting the selection of equipment to perform the specific task.
- Identify advantages over alternatives for achieving each subsystem function, including consumption of utilities.
- Perform economic analyses, identifying capital and operation and maintenance (O&M) costs.
- Compare the economic base of supplementary fuel fired boiler systems with the cost of operating the plants on coal only.
- Provide overall recommendations on site specific boiler plants regarding potential for conversion.

3.0 BACKGROUND

3.1 General

The use of RDF as a supplement to coal in a coal-fired boiler plant provides an alternative to conventional methods of waste disposal. The majority

of such waste-to-energy conversion facilities now operating or in the planning stages, are public utilities. Such utility company participation was first demonstrated at the Union Electric Nermac Plant, St. Louis, in 1972-1975. Other utility companies that use RDF as a supplement to coal are: Ames Municipal Electric Service Power Plant, Wisconsin Electric Power Company's Oak Creek power station, Commonwealth Edison, Long Island Lighting, and Rochester Gas and Electric Co.¹.

The technical issues that are to be considered for each step from solid waste generation to RDF utilization include the following:

- Fuel Preparation.
 - Solid waste generation.
 - Raw waste transport.
 - Raw waste processing.
- Fuel Utilization.
 - Prepared fuel transport to storage.
 - Solid fuel storage.
 - Transportation of stored RDF to boiler.
 - Steam generation.
 - Control of combustion residuals.

Because of many objectionable characteristics of the prepared solid waste and inadequate design of transport, storage, and retrieval systems, many of the recent ambitious refuse and coal-fired schemes have failed.

The objectionable characteristics of prepared solid waste are:

- Very dusty. This leads to the following requirements:
 - An enclosure for the refuse to avoid environmental pollution.
 - An explosion suppressant to prevent damage due to dust explosion.
 - All motive power mechanisms (e.g., sprocket wheels, gear trains, electric motors) must be totally enclosed.
- Compacts easily during storage resulting in bridging and jamming of conventionally designed hoppers and storage bins.
- Very abrasive. This means the pneumatic transport lines, especially elbows, have to be made of abrasive resistant metals.

- Spontaneous combustion of the fuel can occur in the storage bin. Therefore, first-in and last-out scheme of retrieval system has to be examined in terms of fire hazard in the storage bin.

3.2 Fuel Preparation

3.2.1 Solid Waste Generation. In the design and operation of an energy and resource recovery system from municipal solid waste, the solid waste quantities and composition are two important considerations. Several factors affect the quantity and composition of the solid waste stream. Variations in waste quantity occur seasonally. Economic trends also affect waste quantities and composition. With an expanding economy, the waste generation rate increases, and in recessive periods, the waste quantity tends to drop. Institutional factors also influence waste quantity and composition. Such factors include:

- Source separation of salable products as ferrous, aluminum, and glass materials.
- Source reduction programs involving recyclable containers and packaging.

To achieve high performance of a resource recovery facility, an indepth analysis of the local solid waste composition and generation rate, in addition to a market analysis for the sale of salvage fuel and byproducts (ferrous, aluminum, and glass), is essential. Many recent resource recovery facilities have faced the situation in which the market for the ferrous and glass materials has vanished, and the aluminum content of the MSW has dropped drastically. In such a situation, an ambitious resource recovery facility is saddled with large capital intensive processing equipment remaining idle, thereby not producing revenue. An example is the Ames, IA Solid Waste Facility. It does not have an economic market for ferrous and glass materials, and the nonferrous metals are so contaminated that the salvage value of the product is reduced. As a result, the byproduct recovery equipment is not being used.

3.2.2 Raw Waste Transport. The Navy does not normally become involved in the issues relating to the transportation and receiving of raw solid waste. However, if a processing plant is to be located adjacent to a boiler plant site, the involvement of the using organization would become necessary.

Raw solid waste receiving and storage facilities may encroach upon a large section of the available waste processing site. Further, the truck traffic associated with the delivery of the raw solid waste may create conflict with the operation and maintenance of the boiler plant. A boiler plant facility with restricted site areas should, therefore, be concerned about possible problems that may be generated by the waste transport scheme.

3.2.3 Raw Waste Processing. The major technical issue in determining raw waste processing requirements is the compatibility of the RDF with a coal-fired boiler. Raw solid waste is not an adequate supplemental fuel for a coal-burning boiler and, in almost all cases, some level of processing of the solid waste is needed before it becomes an acceptable supplemental fuel for use in the boiler.

There are many different levels of processing ranging from simple shredding operations to complicated multiple-stage shredding, air classification, trommeling, ferrous and nonferrous metals separation, and glass recovery. Each additional level of processing adds to the cost but improves the quality of the fuel.

A boiler combustion chamber is designed to burn a specific fuel. Therefore, the boiler plant personnel must examine the solid fuel burning boiler equipment system and prepare a fuel specification to be compatible with the system. The fuel specification will determine the level of raw solid waste processing required. If retrofitting the boiler equipment is required, the firing rate, particle size, moisture, inert content, and other fuel quality

specifications must be known before an appropriate raw refuse processing system can be designed. Prepared fuel transport and storage design schemes are also affected by the specifications of the prepared fuel.

3.3 Fuel Utilization

3.3.1 Prepared Fuel Transport To Storage. Two schemes of prepared solid fuel transport and storage options are illustrated in figure 3-1. Alternate 1 relates to offsite MSW processing, alternate 2, to processing MSW at the boiler plant site. Prepared refuse fuel transport, storage, and retrieval system designs will directly affect the operation of a boiler plant.

3.3.2 Solid Fuel Storage. The capacity of the storage bin must be matched with the prepared fuel receiving and burning schedules. Refuse fuel preparation and transport normally occurs in one or two working shifts 5 days per week. The refuse derived fuel burning is expected to take place at a constant rate during the 24-hour period 5 days per week excluding holidays and weekends. Therefore, sufficient capacity of the surge bin must be available to account for these schedule differences between boiler requirements and plant production rate. A conservative design approach is to allow the Navy boiler plant to draw the supplemental refuse fuel from the surge bin for 3 days without operation of the raw refuse processing plant.

3.3.3 Transportation of Stored RDF to Boiler. The technical issue in selecting a delivery system to transport RDF to the boiler, involves evaluating and weighing the advantages and disadvantages of pneumatic or mechanical feeding schemes.

Mechanical feeding of the utility boiler can be accomplished either by apron or belt conveyor to the RDF feed hopper of the boiler. In designing mechanical feeding systems, the RDF characteristics of poor flowability and

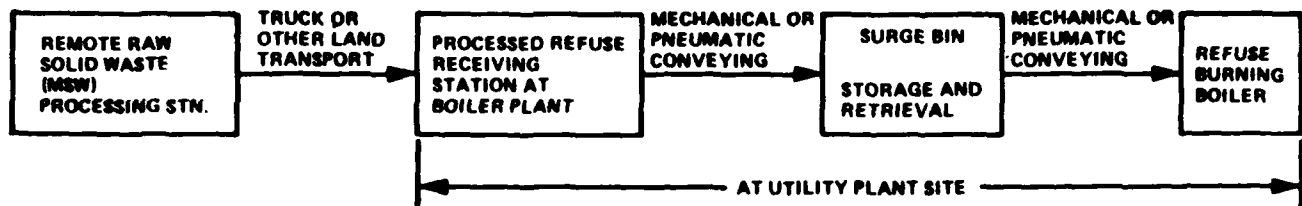

ALTERNATE 1 SCHEME

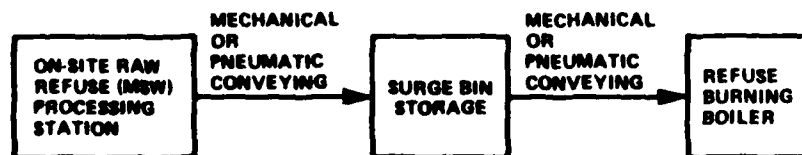

ALTERNATE 2 SCHEME

Figure 3-1. Raw Refuse Processing, Transport, and Retrieval Schemes.

tendency to agglomerate must be considered. In a spreader stoker, the RDF should be discharged into the fuel bed uniformly; and, therefore, a mechanical means of breaking up the clustered RDF has to be provided.

For pneumatic transport and feeding of RDF to the boiler, the following should be considered:

- Design of the transport pipe using abrasion-resistant metals and, as far as possible, straight lengths of pipe.
- The effect of excess air that will enter into the combustion chamber, with the RDF.

3.3.4 Steam Generation. The technical issues associated with the use of supplement refuse fuel in an existing stoker coal-fired boiler are:

- Slagging and fouling of tubes.
- The design of ash handling and disposal systems.
- The design of air pollution control equipment modifications.
- Corrosion and erosion of boiler tubes.
- Adequacy of existing combustion chamber to accept moderately high moisture content fuel and achieve complete combustion.
- Effect of refuse fuel on the primary fuel (coal) combustion in the combustion chamber.
- Ash fusion temperature of the RDF.
- Ash bed depth on the travelling grate.
- Combustion control equipment system modifications.
- Modifications of forced and induced draft fans.
- Effects on overall performance of the steam generator (boiler efficiency).
- Increase in operating and maintenance costs and associated problems.

Each of the above issues should be studied in full before the decision to retrofit an existing stoker coal-fired boiler is adopted.

3.3.5 Control of Combustion Residuals. Combustion chamber bottom ash and fly ash particulates and trace metals are the most important combustion residuals. The technical issues that should be examined for supplemental refuse fuel firing are:

- The change in characteristics of bottom ash.
- The change in the emission characteristics; i.e., particulates, trace metals, and gaseous pollutants.

The bottom ash that will be produced from co-combustion of refuse and coal may contain glass, metals, unburned wood, and even a small percentage of

organics. Although coal ash has some industrial use (e.g., cinder block), contaminated bottom ash disposal from co-combustion may face environmental regulations and restrictions because of the possibility of hazardous trace metals leaching out of the ash. In the State of California, such bottom ash may be classified as hazardous waste material and may, therefore, be allowed only in class I landfill sites. Similarly, the flyash of the supplemental refuse fuel fired boiler may contain many objectionable trace metals.

3.4 Summary

Detailed discussion of the technical issues is presented in later sections in this report. Table 3-1 summarizes the level of importance of these issues.

Table 3-1. Importance of Technical Issues in the Energy Recovery Process¹.

| Steps in Energy Recovery Process | Technical Issues | Level of Importance |
|------------------------------------|--|---------------------|
| Raw waste transport to steam plant | • Land requirement | Low |
| | • Vehicle traffic | Low |
| Processing | • Process technology | High |
| | • Boiler type matching with fuel | High |
| Fuel transport and storage | • RDF storage | Low |
| | • Space requirement | Low |
| | • RDF retrieval | Medium |
| | • Pneumatic transport line wear and plugging | High |
| Boiler system | • Boiler modifications | Medium |
| | • Refuse-fuel standardization, sampling, analysis, and procedure | Medium |
| | • Boiler performance | Medium |
| | • Corrosion and erosion of boiler tubes | High |
| | • Slagging and fouling | High |
| | • Residue handling and disposal | Low |
| • Air and water emissions | High | |

4.0 TECHNICAL CONSIDERATIONS

4.1 Preparation of MSW as RDF

The design of a solid waste processing system is a function of the level of need to:

- Improve the efficiency of solid waste management systems.
- Recover usable materials.
- Recover energy products.

MSW is a difficult material to handle and process. Some of the qualities of the MSW that contribute to the difficulties are:

- It is a highly heterogeneous fuel. Although thousands of MSW characterizations have been computed, the only conclusion drawn from these investigations is that it is difficult to write a specification for a standard MSW.
- The constituents of MSW come in difficult shapes, forms, and sizes.
- It does not flow well. A steep angle of repose is needed to ensure continuous flow of refuse from a refuse hopper. Bridging is common in almost all designs of hopper feeding devices.
- It is highly abrasive. Case histories of pneumatic transport of processed MSW reveal severe wear problems to the transport pipe lines.
- The moisture content varies considerably (from 10 to 50%).
- It tends to compact in storage. A smooth, constant rate of retrieval of stored processed refuse has been a major problem.
- It is putrescible.
- In storage, spontaneous combustion of the refuse is very possible.
- Stored MSW emits an offensive odor that attracts flies and rodents and creates an unsanitary environment.
- Its overall characteristics vary seasonally from community to community and from generator to generator.

The raw MSW is processed by various combinations of equipment that can include one or more of the following operations: trommel screening, shredding,

air classification, magnetic and nonferrous separations, glass recovery, drying, and densification.

In determining the level of processing, three efficiencies must be considered relative to the material combustion and heat transfer rate of the final RDF product desired²:

- Fuel efficiency (FE) is the parameter that indicates net available energy value of the fuel produced by various processes. This FE value is calculated by subtracting the inplant MSW processing energy from the chemical energy of the RDF and dividing by the MSW chemical energy.
- Boiler efficiency (BE) indicates the fraction of the chemical energy of the RDF which can be converted in producing steam. An RDF purchaser uses this measure to evaluate the relative value of equivalent amounts of supplementary fuel.
- System efficiency (SE) specifies the fraction of input waste which is converted to steam. This parameter enables the boiler plant engineer to compare different types of energy products on an equivalent basis. This value is expressed as $SE = FE \times BE$.

A typical material and energy balance of an MSW-to-solid-fuel (RDF) conversion process train is shown in figure 4-1.

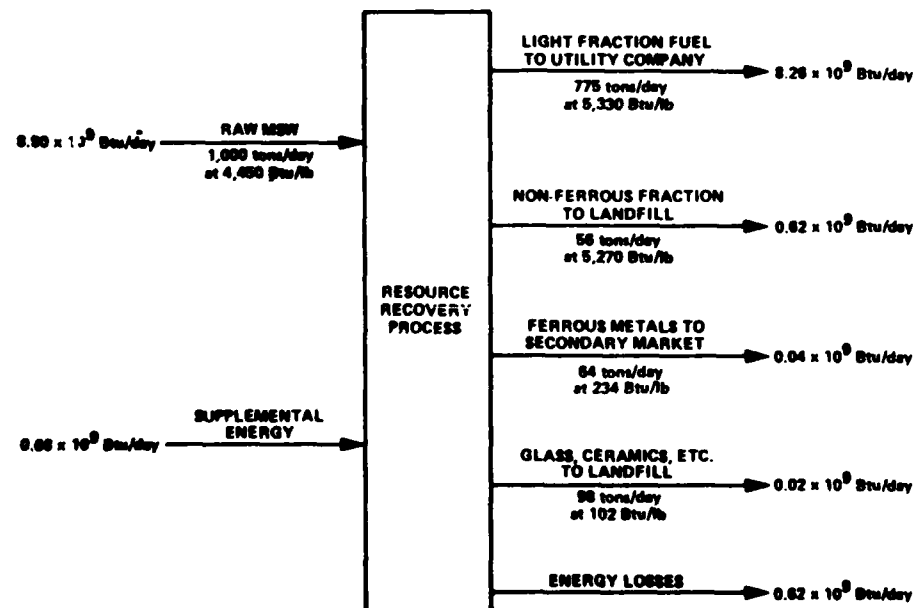

Figure 4-1. Material and Energy Balance for a Resource Recovery Plant.³

Computations of gross and net fuel efficiencies as a utility fuel, from the data in figure 4-1, are given as follows:

Gross fuel efficiency in the conversion of MSW to RDF

$$= \frac{\text{Energy content (chemical heat) of the RDF produced}}{\text{Energy content of the raw MSW}}$$

$$= (8.26/8.9) \times 100 = 93\%$$

Net fuel efficiency of the conversion

$$= \frac{\text{Energy content of RDF produced} - \text{power required to process MSW}}{\text{Energy content of the raw MSW}}$$

$$= \frac{8.26 - 0.66}{8.9} \times 100 = 85\%$$

Overall system efficiency, calculated with the assumption that RDF is burned in an electric power plant with a heat rate of 10,000 Btu/kwh and having a power generation efficiency of 34%, equals $(0.85 \times 0.34) \times 100$, or 29%.

Actual attainable boiler efficiencies in the combustion of MSW and RDF in different municipal boiler environments, as measured during industrial studies, are given below:³

| <u>Description</u> | <u>Boiler Efficiency (%)</u> |
|---|------------------------------|
| Mass burning of unprocessed MSW in a dedicated boiler | 61.7 |
| Coarse RDF (\leq 4-inch size) burning in a dedicated boiler (stoker-fired) | 73.5 |
| Coarse RDF (\leq 3-inch size) burning as a dedicated fuel in a retrofitted stoker-fired boiler | 72.0 |
| Fluff RDF (\leq 1-1/2-inch size) burning as a dedicated fuel in a retrofitted stoker coal-fired boiler | 75.4 |
| By comparison: | |
| Co-combustion of 50% RDF and 50% coal in a retrofitted stoker coal-fired boiler, based upon the expected operation condition of the average Navy boiler | 72.0 |
| 100% coal combustion in a stoker coal-fired boiler, based upon the average operating condition of existing Navy boilers | 78.0 |

4.1.1 Fuel Specification. Specifications should be established for the RDF that will be acceptable either for co-combustion with coal in a retrofitted stoker coal-fired boiler or for 100% RDF burning in the same boiler. It is difficult to write a strict specification for RDF processed from MSW. However, it is important for steam plant operation that a specification guideline be prepared so that the RDF supplier can be made responsible to design the MSW processing system to produce a specified fuel. A general outline for the specification of RDF includes:

- Particle Size: The maximum size of the RDF particle shall be such that 95% of the particles by weight will pass through a 2-inch square mesh screen and 100% of the particles will pass through a 2-1/4-inch square mesh screen.
- Gross Heating Value: The gross heating value of the RDF delivered at the receiving facility shall not be less than 5000 Btu/lb as determined by a bomb calorimeter on an as-received basis. The heating value test shall be conducted by the ASTM D-2015-66 method.
- Moisture Content: The maximum moisture content of the RDF delivered at the boiler plant fuel receiving station shall not exceed 20% by weight. The ASTM D-271-68 test procedure shall be adopted in conducting the test procedure.
- Ash Content: The maximum total ash content (water soluble plus acid insoluble) of the RDF delivered at the receiving station shall not exceed 15% by weight on an as-received basis. The total ash content tests shall be conducted by the ASTM D-271-68 test procedure.
- Chlorine Content: The maximum total chlorine content of the RDF delivered at the receiving facility shall not exceed 0.5% by weight on an as-received basis. The total chlorine content shall include water-soluble chlorides and organically-bound chlorine.
- Sulfur Content: The maximum sulfur content of the RDF delivered at the receiving station shall not exceed 0.4% by weight on an as-received basis.

4.1.1.1 Existing Usage of RDF. In the Ames, IA facility, which is the only known facility using retrofitted boilers, the unscreened as-received MSW is processed into RDF by two-stage shredding with magnetic separation between the

two stages. The size distribution of RDF discharged from the storage bin is presented in table 4-1. The data shows that 98.4% by weight of the RDF particles are less than 63 mm (2.48 inches) diameter.

Variations of the moisture and heating values that can be expected with RDF, based on the Ames, IA data, are shown in figures 4-2 and 4-3. Comparisons of daily samples of RDF taken over a 1-year period at the Ames and St. Louis facilities are given in table 4-2. Bulk density, heating value, moisture content, and chemical analysis of RDF discharged from the storage bin are presented in table 4-3. It is noted from this table that the mean heating value of the as-received RDF is 13,050 KJ/Kg (5625 Btu/lb) and the moisture and ash contents of the RDF are 23.03% and 17.37%, respectively. As expected,

Table 4-1. Size Distribution of RDF Discharged from the Storage Bin (As received, all percents by weight)^a.

| Sample No. (Test day) | Size (mm) ^{a/} standard ASTM E-11 designation | | | | | | Geometric | |
|--------------------------|--|---------------|-----------------|------------------------------------|-----------------|-----------------|------------------|-----------------------|
| | % Larger than 63 (2.48") | 63 (2.48") | 38.1 (1.50") | % Smaller than 19.0 (0.748") | 9.5 (0.374") | 4.8 (0.188") | Mean diameter | Standard deviation |
| b/ 2 | 1.4 | 98.6 | 79.9 | 18.7 | 14.5 | 10.3 | 22.6 | 2.17 |
| c/ 8 | 3.2 | 96.8 | 85.2 | 65.5 | 38.2 | 22.2 | 12.4 | 2.56 |
| 9 | 0.8 | 99.3 | 88.5 | 67.7 | 40.4 | 22.5 | 11.7 | 2.46 |
| 10 | 1.2 | 98.8 | 93.9 | 81.5 | 58.1 | 35.1 | 8.4 | 2.36 |
| 11 | 0 | 100.0 | 91.1 | 75.8 | 58.0 | 28.6 | 9.2 | 2.42 |
| 12 | 1.1 | 98.9 | 93.2 | 71.0 | 48.6 | 26.5 | 10.2 | 2.42 |
| 13 | 3.3 | 96.7 | 89.0 | 73.3 | 50.9 | 23.3 | 10.5 | 2.47 |
| 14 | 3.8 | 96.2 | 84.3 | 66.2 | 41.5 | 24.5 | 12.0 | 2.64 |
| d/ Mean | 0.1 | 99.9 | 95.1 | 68.9 | 38.4 | 25.1 | 11.1 | 2.35 |
| Mean | 1.7 | 98.4 | 88.9 | 65.4 | 43.2 | 24.3 | 12.0 | 2.42 |

a/ 25.40 mm = 1"

b/ Single stage shredding due to second stage shredder out of service because of bearing failure. Second stage shredder not back in service until March 18, 1976.

c/ Extra sample taken April 22, 1976.

d/ Mean does not include single stage shredding data from March 23, 1976.

Note. First stage shredder grate size - 229 x 229 mm (9 x 9 in.).
Second stage shredder grate size - 76 x 127 mm (3 x 5 in.).

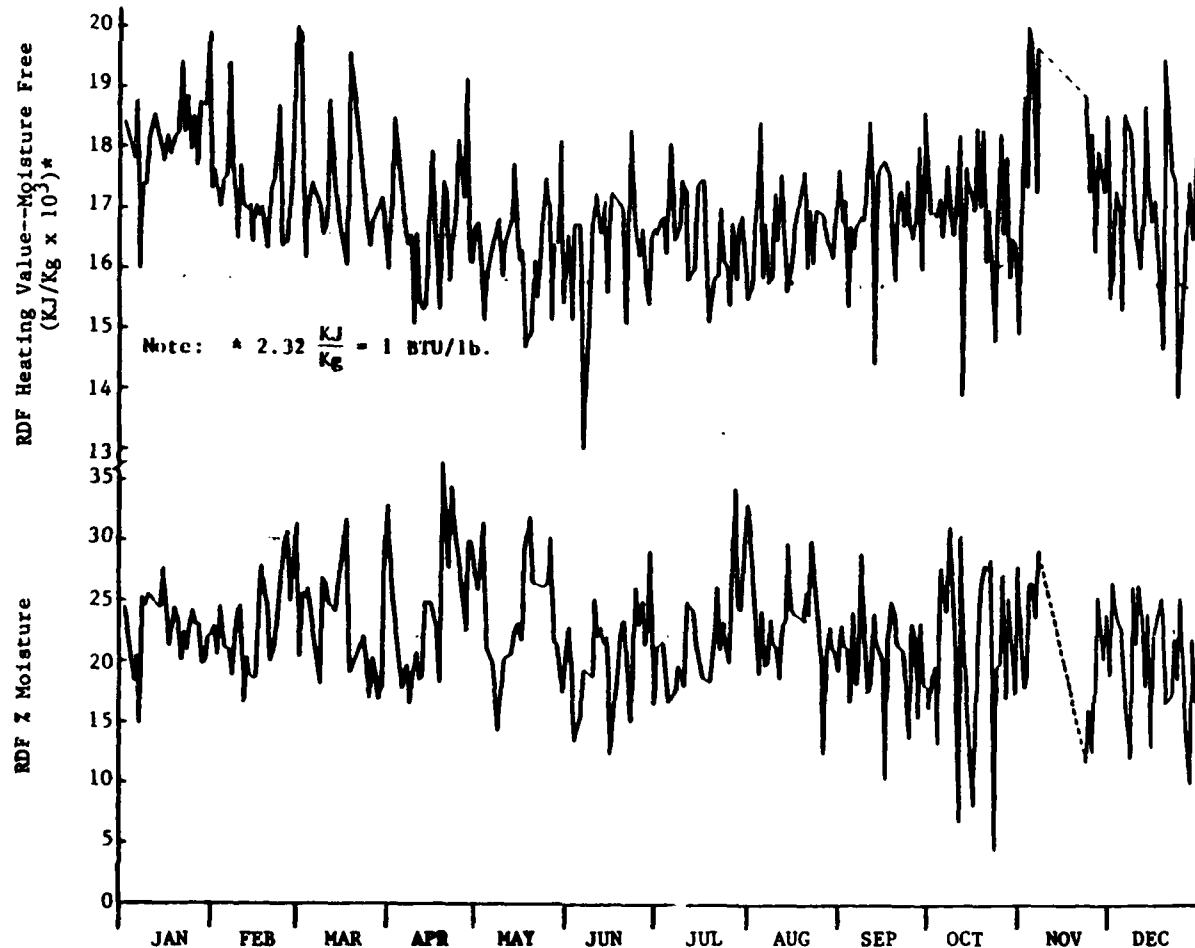

Figure 4-2. Daily RDF Moisture and Heating Values at Ames Municipal Power Plan - 1976⁴.

there were considerable variations of RDF characteristics from the daily samples. Table 4-4 presents the range of maximum, minimum, and mean values; the standard deviation, confidence interval; and coefficient of variation for the complete spectrum of RDF constituents.

The coefficient of variation is a measure of variability, because it expresses the standard deviation as a percent of the mean. As the absolute value of one characteristic increases compared to that of a different characteristic; the standard deviation may also increase. However, a larger standard deviation does not necessarily mean larger variability; and, thus, the

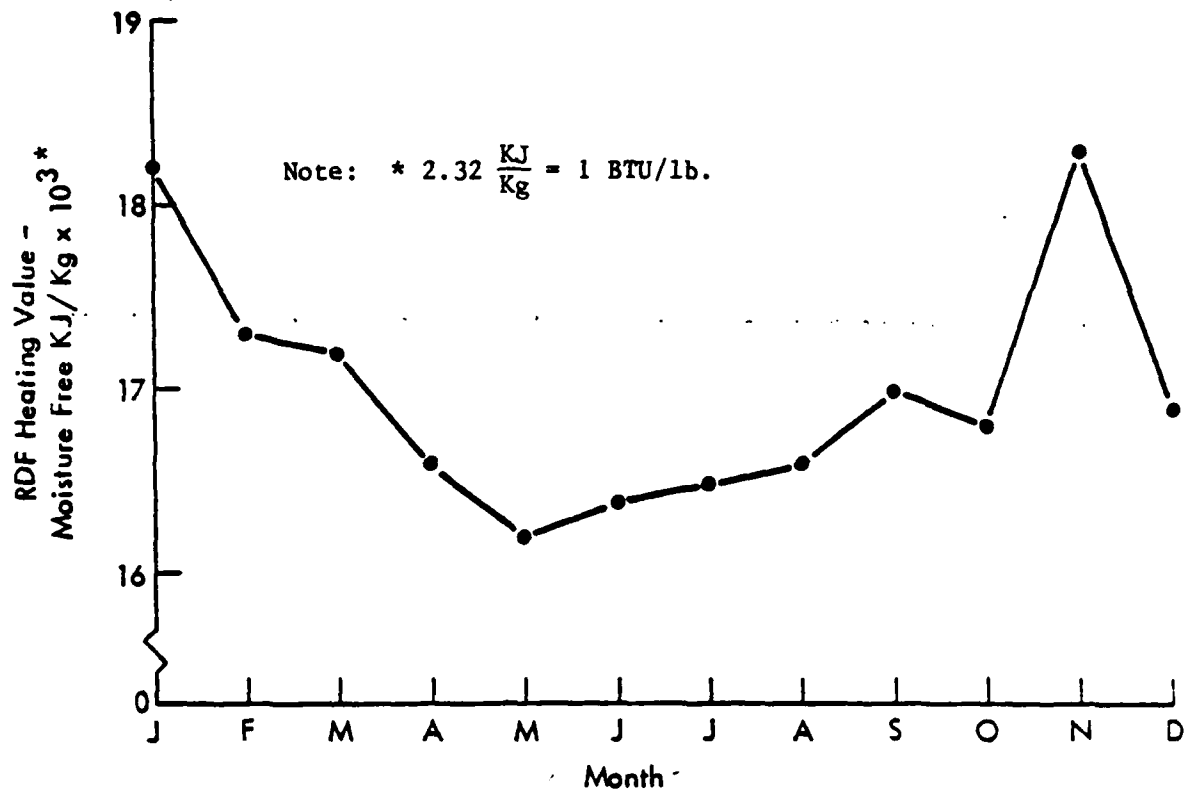

Figure 4-3. Monthly Average RDF Moisture and Heating Values at Ames Municipal Power Plant - 1976⁴.

Table 4-2. Comparison of Daily Samples of RDF Taken Over 1-Year Period, St. Louis - September 1974 through September 1975, Ames - January through December 1976^a.

| Characteristic | Moisture % | | Heating value (kJ/kg) ^b | | | |
|------------------------|------------|-------|------------------------------------|---------|---------------|---------|
| | St. Louis | Ames | As received | | Moisture free | |
| | | | St. Louis | Ames | St. Louis | Ames |
| Mean \bar{x} | 26.55 | 22.23 | 10,636 | 13,188 | 14,494 | 16,967 |
| Maximum value | 42.2 | 36.38 | 13,613 | 16,970 | 16,816 | 20,239 |
| Minimum value | 2.3 | 4.31 | 6,932 | 9,678 | 10,503 | 13,023 |
| Number of samples, n | 97 | 286 | 97 | 268 | 97 | 268 |
| Standard deviation, Sx | 7.275 | 4.864 | 1,370.3 | 1,297.2 | 1,400.5 | 1,141.0 |

Note: ^a2.32 $\frac{\text{KJ}}{\text{Kg}}$ = 1 BTU/lb.

Table 4-3. Bulk Density, and Proximate and Ultimate Analysis of RDF Discharged From the Storage Bin (As Received, all Percents by Weight ASTM Methods D271 for all Values Except Bulk Density)^a.

| Sample No. (test day) | Bulk density (kg/m ³) | Heating value (kJ/kg) ^b | Moisture (%) | Ash (%) | Volatile matter (%) | Fixed carbon (%) | Carbon (%) | Hydrogen (%) | Oxygen (%) | Sulfur (%) | Chlorine (%) | Nitrogen (%) |
|-----------------------|-----------------------------------|------------------------------------|--------------|---------|---------------------|------------------|------------|--------------|------------|------------|--------------|--------------|
| 1 | 134.7 | 13,328 | 22.00 | 11.12 | 57.54 | 9.34 | 32.58 | 4.91 | 28.32 | 0.46 | 0.25 | 0.16 |
| 2 | 97.0 | 12,406 | 19.38 | 17.44 | 58.21 | 4.97 | 32.27 | 4.36 | 25.40 | 0.60 | 0.26 | 0.29 |
| 3 | 152.2 | 11,475 | 29.24 | 21.38 | 48.56 | 0.82 | 28.36 | 4.21 | 15.84 | 0.23 | 0.20 | 0.54 |
| 4 | 104.4 | 13,812 | 18.65 | 15.24 | 59.21 | 6.90 | 33.59 | 4.61 | 27.14 | 0.29 | 0.16 | 0.32 |
| 5 | 129.5 | 13,120 | 19.71 | 17.99 | 56.69 | 5.61 | 32.41 | 4.88 | 24.02 | 0.33 | 0.17 | 0.49 |
| 6 | 157.0 | 12,084 | 31.77 | 19.39 | 46.57 | 2.27 | 27.98 | 4.64 | 18.92 | 0.64 | 0.25 | 0.41 |
| 7 | 127.8 | 11,875 | 28.32 | 15.61 | 52.48 | 3.59 | 29.41 | 4.98 | 19.94 | 0.88 | 0.22 | 0.64 |
| 8 | 122.5 | 13,948 | 20.97 | 13.74 | 57.22 | 8.07 | 33.90 | 5.08 | 25.21 | 0.60 | 0.14 | 0.36 |
| 9 | 156.0 | 15,219 | 19.92 | 19.48 | 55.55 | 5.05 | 32.66 | 4.96 | 21.99 | 0.44 | 0.21 | 0.34 |
| 10 | 137.6 | 13,099 | 25.61 | 13.55 | 54.56 | 6.38 | 31.33 | 4.68 | 24.00 | 0.30 | 0.20 | 0.33 |
| 11 | 122.4 | 11,909 | 25.10 | 22.52 | 51.12 | 1.26 | 26.57 | 4.20 | 20.51 | 0.27 | 0.26 | 0.57 |
| 12 | 116.1 | 13,413 | 20.82 | 18.25 | 56.16 | 4.77 | 30.23 | 5.08 | 24.56 | 0.29 | 0.32 | 0.45 |
| 13 | 125.5 | 13,914 | 20.92 | 18.77 | 54.99 | 5.32 | 31.03 | 4.95 | 23.38 | 0.36 | 0.19 | 0.40 |
| 14 | 113.8 | 13,104 | 20.05 | 18.76 | 56.32 | 4.87 | 29.72 | 5.18 | 25.10 | 0.26 | 0.52 | 0.34 |
| Mean | 128.3 | 13,050 | 23.03 | 17.37 | 54.65 | 4.94 | 30.86 | 4.77 | 22.88 | 0.43 | 0.24 | 0.42 |

Notes: ^a 16.02 kg/m³ = 1 lb./ft³

^b 2.32 $\frac{\text{KJ}}{\text{Kg}}$ = 1 BTU/lb.

Table 4-4. Variability of Daily Values of Characteristics of RDF Discharged from the Storage Bin (As Received, All Percents by Weight)^a.

| Item | Range | | \bar{X} Mean | n number of samples | Sx standard deviation | Variability about the mean (\pm) at 95% confidence coefficient | CV coefficient of variation % |
|---|------------------|------------------|-------------------|------------------------------|-----------------------------|--|--|
| | Maximum value | Minimum value | | | | | |
| Analysis of RDF | | | | | | | |
| Bulk density (kg/m ³) | 157.0 | 97.0 | 128.3 | 14 | 18.14 | 10.5 | 14.1 |
| Heating value (kJ/kg) | 15,219 | 11,475 | 13,050 | 14 | 1021.6 | 589.8 | 7.83 |
| Moisture (%) | 31.77 | 18.65 | 23.03 | 14 | 4.212 | 2.43 | 18.29 |
| Ash (%) | 22.52 | 11.12 | 17.37 | 14 | 3.170 | 1.83 | 18.25 |
| Volatile matter (%) | 59.21 | 46.57 | 54.65 | 14 | 3.702 | 2.14 | 6.77 |
| Fixed carbon (%) | 9.34 | 0.82 | 4.95 | 14 | 2.405 | 1.39 | 48.64 |
| Carbon (%) | 33.90 | 26.57 | 30.86 | 14 | 2.224 | 1.28 | 7.21 |
| Hydrogen (%) | 5.18 | 4.20 | 4.77 | 14 | 0.324 | 0.19 | 6.79 |
| Oxygen (%) | 28.32 | 14.92 | 22.85 | 14 | 3.903 | 2.25 | 17.06 |
| Sulfur (%) | 0.88 | 0.23 | 0.43 | 14 | 0.190 | 0.11 | 44.77 |
| Chlorine (%) | 0.59 | 0.14 | 0.24 | 14 | 0.110 | 0.06 | 45.12 |
| Nitrogen (%) | 0.64 | 0.29 | 0.42 | 14 | 0.106 | 0.06 | 25.44 |
| Particle size | | | | | | | |
| Geometric mean diameter mm ^{g/} | 12.4 | 8.4 | 12.0 | 8 | 1.392 | 1.2 | 13.02 |
| Percent larger than 63 mm | 3.8 | 0 | 1.7 | 9 | 1.421 | 1.1 | 85.85 |
| Analysis of RDF ash | | | | | | | |
| SiO ₂ (%) | 54.10 | 41.82 | 48.19 | 14 | 4.059 | 2.34 | 8.42 |
| Al ₂ O ₃ (%) | 18.17 | 8.45 | 11.75 | 14 | 2.288 | 1.32 | 19.47 |
| Fe ₂ O ₃ (%) | 8.13 | 2.71 | 4.29 | 14 | 1.332 | 7.69 | 31.04 |
| TiO ₂ (%) | 1.96 | 1.07 | 1.45 | 14 | 0.256 | 0.15 | 17.74 |
| P ₂ O ₅ (%) | 1.25 | 0.28 | 0.79 | 14 | 0.276 | 0.16 | 34.86 |
| CaO (%) | 15.48 | 10.40 | 12.71 | 14 | 1.608 | 0.93 | 12.66 |
| MgO (%) | 3.19 | 1.95 | 2.38 | 14 | 0.312 | 0.18 | 13.10 |
| Na ₂ O (%) | 5.22 | 3.46 | 4.37 | 14 | 0.598 | 0.35 | 13.68 |
| K ₂ O (%) | 2.26 | 1.52 | 1.80 | 14 | 0.244 | 0.14 | 13.56 |
| Fusion temperature of RDF ash - °C | | | | | | | |
| Reducing atmosphere | | | | | | | |
| Initial deformation (IT) | 1154 | 1032 | 1106 | 14 | 41.47 | 72 | 3.75 |
| Softening (ST) | 1171 | 1116 | 1143 | 14 | 18.15 | 31 | 1.59 |
| Hemispherical (HT) | 1199 | 1121 | 1158 | 14 | 23.57 | 41 | 2.04 |
| Fluid (FT) | 1249 | 1127 | 1177 | 14 | 37.42 | 65 | 3.18 |
| Oxidizing atmosphere | | | | | | | |
| Initial deformation (IT) | 1188 | 1104 | 1149 | 14 | 23.48 | 41 | 2.04 |
| Softening (ST) | 1204 | 1127 | 1165 | 14 | 28.62 | 50 | 2.46 |
| Hemispherical (HT) | 1238 | 1132 | 1181 | 14 | 37.10 | 64 | 3.14 |
| Fluid (FT) | 1282 | 1138 | 1197 | 14 | 45.53 | 79 | 3.80 |

^g Particle size does not include high value on March 23, 1976, due to single stage shredding.

coefficient of variation is a method of describing the amount of variability. The analysis of data of table 4-4 shows that the variability expressed often becomes quite high when the mean values are very low, such as for sulfur, chlorine, nitrogen, ash, P_2O_5 and particle size over 63 mm size.

4.1.1.2 RDF Design. In general, if a "dedicated" spreader stoker boiler was selected, then a coarse RDF (RDF-2) would normally be adequate. The preparation of RDF-2 involves a primary shredding followed by screening, air classification, and magnetic separation.

Normally, if a trommelling operation is instituted prior to the first stage shredding and appropriate grating is used in the shredder, the particle size is significantly reduced. It is believed that the RDF specification of 95% of the particles passing a 2-inch square mesh screen can be achieved by a processing train consisting of an appropriately sized trommel screen followed by a single-stage shredder.

When RDF-2 is co-fired with coal in a stoker coal-fired boiler, a part of the RDF burns in suspension and the rest burns on the bottom grates. This mode of semisuspension firing is widely used for burning fibrous wastes, such as bark and bagasse³.

A fluff RDF (RDF-3), as a comparison, is normally prepared through two-stage shredding of MSW to produce 3/8-inch to 1-1/2-inch particle size product. The total RDF-3 preparation process includes removal of ferrous and nonferrous metals, screening, air classification, and glass separation. The RDF-3 is normally burned in suspension in a retrofitted pulverized coal-fired boiler. The boiler is retrofitted with a drop grate at the bottom of the boiler to allow burnout of the RDF not completely burned in suspension. RDF-3 firing is generally called full suspension burning.

The selection of RDF-2 or RDF-3 becomes a function of boiler equipment design and system economics. An analysis of current field operating conditions indicates that the high heat value (HHV) of RDF that can be expected will range between 5625 Btu/lb to 6000 Btu/lb dependent upon the degree of refinement. To obtain the additional refinement between RDF-2 and RDF-3, secondary shredders and air classifiers have to be added to the processing cycle necessitating more capital outlay, larger processing facilities, and increased maintenance and repair. The total Btu output improvement fails to offset the cost increases when burning in a stoker coal-fired boiler.

Based upon economic considerations, the degree of refinement should be limited to that necessary to provide a practical and economical fuel mix; i.e., RDF-2 would be more appropriate for a stoker coal-fired boiler. As a result, RDF-2 was selected to be used as the primary refuse derived fuel for the purposes of this study. RDF-3 which is similar to fluff RDF, would be required when burning in conjunction with pulverized coal necessitating a high degree of suspension burning.

4.1.2 Processing Subsystem. The initial step in designing an MSW processing plant is to evaluate the type of steam load demands to be experienced at the activity including the minimum loads and duration of minimum loads. A typical sizing of a plant in terms of RDF produced per day can be calculated as follows:

Assumptions

Fuel - RDF-2

Fuel Preparation = 100% RDF-2

Boiler Capacity (Output) = 150×10^6 Btu/hr, retrofitted stoker coal-fired boiler

Operating Criteria

Heating value of RDF-2 = 13,050 KJ/Kg (5,625 Btu/hr) as-received basis
(see tables 4-2 and 4-3)

Thermal efficiency = 66% for dedicated RDF
= 72% for 50% RDF and 50% coal

Boiler operation = 24 hours

Calculation

For 100% RDF firing, the

$$\begin{aligned} \text{RDF feed rate} &= \frac{150 \times 10^6}{0.66(5,625)(2000)} \\ &= 20.2 \text{ tons/hr} \\ &= 485 \text{ tons/day} \end{aligned}$$

Normally, MSW processing plants operate 8 to 16 hours daily, and preventive maintenance is done in the second and third shifts.

If the boiler is retrofitted for 100% RDF-2 fuel firing only and there is no standby boiler to carry the boiler plant load, redundancy in the MSW process equipment train will be needed. However, if the boiler plant contains a full capacity standby boiler, then this need for a costly standby parallel MSW processing train can be eliminated. If there is a breakdown of the MSW processing plant, the fossil-fired boiler should be energized to satisfy the steam demand load.

For co-combustion of RDF and coal, a single train of MSW processing equipment will suffice. During a breakdown of the MSW processing train, the boiler will be fired by coal only.

The hourly boiler fuel feed rate to the 150×10^6 Btu/hr boiler, and the RDF-2 processing equipment capacity are shown in table 4-5 for different percentages of coal and RDF-2.

Table 4-5. MSW Processing Train Capacities at Different RDF Inputs.

| Case | Proportional Fuel Energy (%) | Heating Value of Fuel Component (Btu/lb) | Boiler Conversion Efficiency (%) | Fuel Feed Rate to Boiler (Tons/hr) | Double Shift MSW Processing Train Capacity (Tons/hr) | Remarks |
|------|------------------------------|--|----------------------------------|------------------------------------|--|--------------------------------------|
| 1 | 100%-RDF-2 | 5,625 | 66 ¹ | 20.20 | 35 | Redundancy in process train required |
| 2 | 100% Coal | 13,000 | 78 ¹ | 7.40 | - | - |
| 3 | 50% Coal | 13,000 | 72 ¹ | 4.01 | 16 | Single train adequate |
| | 50% RDF-2 | 5,625 | 72 ¹ | 9.26 | | |
| 4 | 75% Coal | 13,000 | 75 ¹ | 5.77 | 8 | Single train adequate |
| | 25% RDF-2 | 5,625 | 75 ¹ | 4.44 | | |

NOTE: ¹Boiler conversion efficiencies based on utilization of existing Navy boilers (average age: 30 years). For new boilers, use higher efficiency.

A typical MSW processing train to prepare RDF-2 type fuel is shown in figure 4-4. There are many different ways a process train system can be designed to produce RDF-2 fuel. However, the design presented in figure 4-4 is preferred based on the following considerations:

- Employment of the trommel screen ahead of the shredder will aid the separation of maximum quantities of glass and metals. This will prolong shredder life, and the organic stream will contain only a small amount of glass.
- Magnetic separation of ferrous metals from MSW is proposed because the magnetic separator is a reliable trouble-free item of equipment and scrap iron is valuable.
- Recovery of aluminum cans from MSW has been omitted primarily because the percentage of aluminum in MSW is very low. The high price of aluminum scrap paid by the recycling centers has caused many households to salvage the aluminum cans from domestic refuse for direct sale to the recycling centers. In addition, the prevailing technology of aluminum separation (Eddy current or linear induction

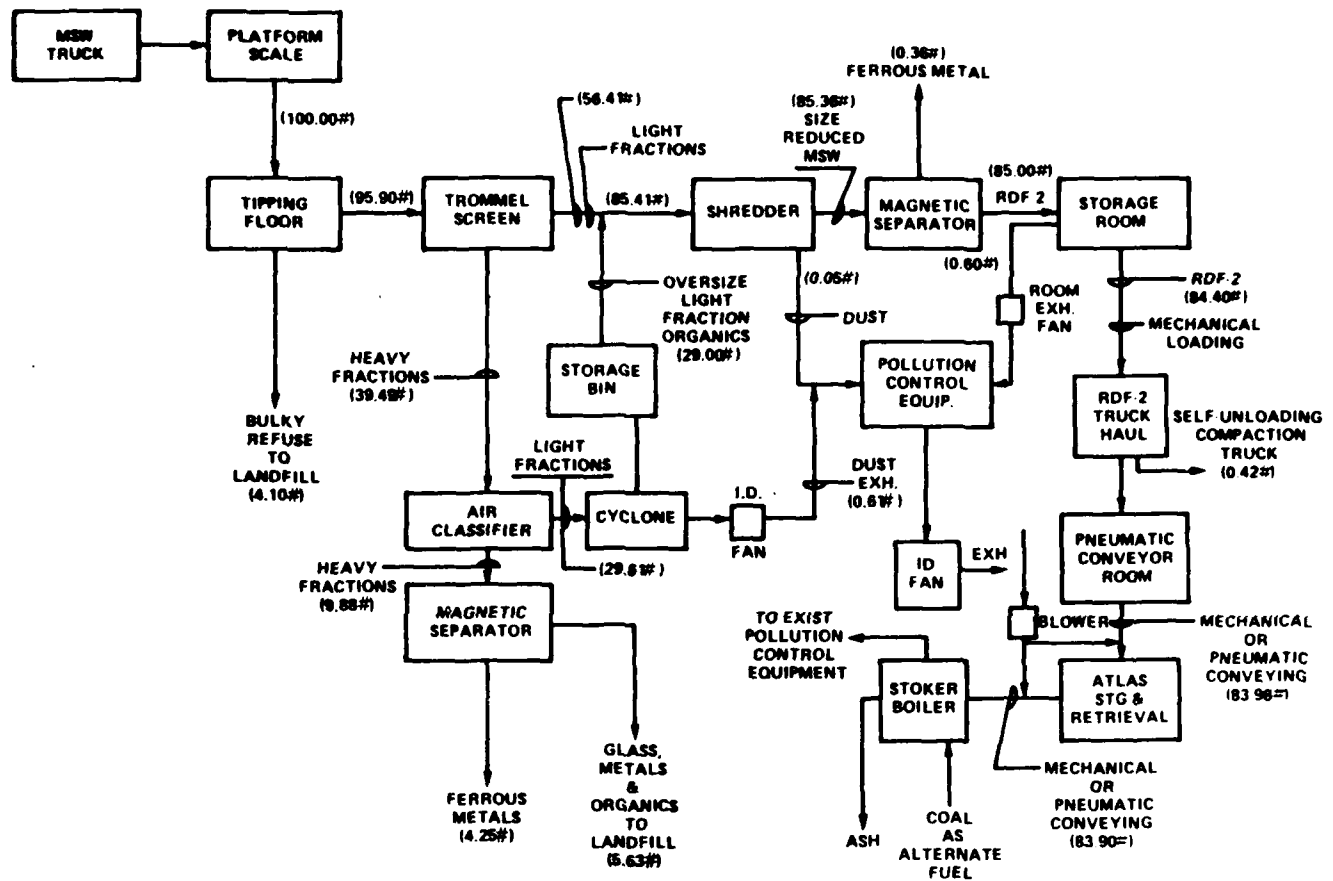

Figure 4-4 Flow Diagram of an MSQ Processing Plant to Produce RDF-2 Fuel.

motors) does not separate only aluminum. Normally, the separated aluminum stream is contaminated with organics and other types of nonferrous metals. As a result, the attractiveness of the separated aluminum is reduced considerably in the scrap market.

- Glass recovery has been omitted. The reasons for this are that the mixed color glass has very little demand in the glass industry, and also the available technology has not been proven to be reliable to the extent that it can be recommended for this type of project.
- Use of single-step air classification will recover much of the light fraction organics from the discard stream (underflow) of the trommel screen. The recovered fuel value of these organics will increase the thermal efficiency of the plant process.

The sequence of MSW processing train operations are:

- The raw MSW is brought into the plant by municipal or private refuse trucks. Each truck is weighed (empty and full load) and the amount of refuse brought into the plant is recorded.

- The trucks deposit the refuse to the tipping floor or the refuse pit.
- The as-received refuse is sorted for large bulky discards.
- The remaining refuse is fed to the trommel screen. The trommel screen should be designed with the provision for tearing out the plastic refuse bags.
- The heavy fraction stream of the trommel screen is generally less than 4 inches in size and consists of metals, glass, wood, and miscellaneous organics and inert material.
- The light fraction stream consists mainly of organics (paper, etc). However, some metals and glass will also be in the light fraction stream.
- The heavy fraction stream of the trommel is then air classified, and the light fraction materials are separated out and recycled back to the light fraction stream of the trommel that is traveling to the primary shredder.
- The heavy fraction stream of the air classifier contains metals, glass, and some heavy organics, such as wood, heavy plastics, and bundled paper. This heavy fraction then travels under a magnetic separator unit. The ferrous materials are separated and collected in a recovery bin for eventual sale to the ferrous scrap metal dealers.
- The nonferrous inerts and contaminated organics are collected for disposal in landfills.
- The light fractions of the trommel screen unit, along with the air classified light organic fractions, are then fed to the primary shredder for size reduction.
- The size-reduced MSW will contain some metals and glass. This stream then travels under a second magnetic separator where the ferrous metals are sorted out, and the remainder of the materials becomes RDF-2 fuel.

It should be noted that many designers may propose to refine the second stage magnetically separated refuse by a secondary air classification or by a trommel screen. If selected, such trommel screens should be designed with 1/2- to 1-inch diameter holes, so that the ground glass, nails, stones, etc., can be separated out from the traveling stream. However, it should be noted that this trommelling operation will also cause loss of some organics. When a traveling

grate stoker is used in a boiler, it can easily handle RDF-2 contaminated with glass and metal; therefore, the addition of a second air classifier or a trommel screen is not recommended since it will add to the capital investment and maintenance costs. The proposed process design as discussed, will result in increased reliability of the overall processing system.

The process design should also include means of cleaning the shredder and exhausts in the RDF-2 storage room by means of an appropriately designed particulate collection system (baghouse, scrubber, or electrostatic precipitator). Mechanical cyclones are not recommended for this type of flow stream. Cyclones operate on an inertial separation process and are excellent for picking up large particles. In general, they are inadequate for picking up minute dust particles.

Description of the major MSW processing train components with recommendations on hardware selection are contained in appendix A.

4.1.3 Transport and Delivery Subsystems. For a successful solid waste processing facility design, a systematic engineering approach for planning a solid waste material handling system is needed. In designing a solid waste handling and conveying system, the first step is to study the requirements for material handling including:

- Collecting data on the characteristics of the solid waste to be handled, such as maximum size, specific weight (lb/ft^3), flowability, dust, etc.
- Collecting data on physical and chemical properties of materials to be transported including temperatures, corrosiveness, and abrasiveness.
- Establishing requirements for the transport system in terms of volume to be handled and the distance to be transported.
- Studying the plant arrangement, size, and the final point of disposal, as well as the method by which the solid waste is to be transferred or loaded onto the conveyor.

- Establishing the profile of the travel path in terms of deviations from the horizontal travel, angle of inclination, vertical lift, horizontal carry length, and complexity of handling (interconnecting flow path).

Processed and unprocessed solid wastes are conveyed by the following types of conveyors:

- Belt conveyor - preferably processed MSW.
- Pan (apron) conveyor - raw MSW.
- Drag chain conveyor - ash and residue.
- Screw conveyor - dry processed MSW (RDF).
- Vibrating conveyor - dry processed MSW (RDF).
- Pneumatic conveyor - dry fine processed MSW (RDF).

If a processing plant is located in close proximity to the boiler plant, conveyors could be designed to provide the total transport and delivery subsystem. However, based upon reliability requirements and economics, a self-unloading transport truck is proposed to pick up RDF from the solid waste processing facility and deliver it to the boiler plant, when the MSW processing plant is located 1/4 mile or more from the boiler plant. Conveyors would be employed at the boiler plant only. Figure 4-5 shows a proposed scheme for delivery of the RDF. The advantages of the truck transport subsystem are:

- Greater reliability.
- Lower capital investment costs.
- Lower facilities maintenance costs.

Disadvantages include:

- Increase mobile equipment
- Increase operational personnel

The major components of the transport and delivery subsystem are detailed in appendix A.

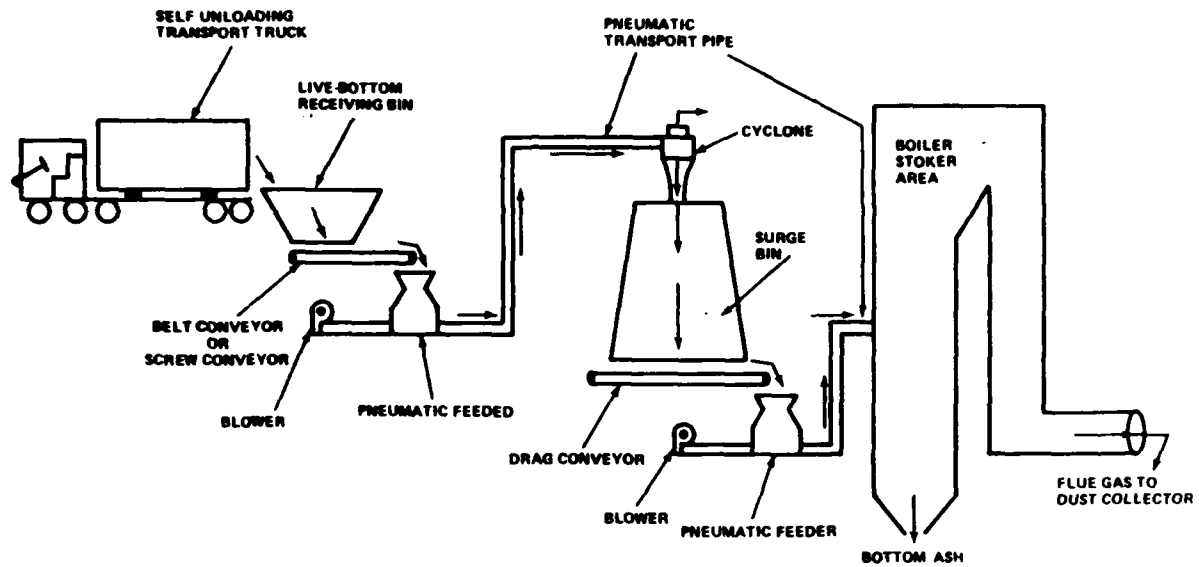

Figure 4-5. Proposed Pneumatic Transport of RDF and Boiler Firing Scheme¹³.

4.1.4 Storage and Retrieval of RDF. A design of the storage and retrieval subsystems should incorporate controlled or reduced pile height and continuous or frequent movement of material. Many problems exist due to the difficulty in producing uniform products. These problems include bridging, arching, ratholing, compaction, abrading, erratic retrieval rates, and fire.

Stringy fibrous materials are one major concern that can paralyze storage and retrieval systems by their pronounced tendency to wrap around rotating equipment. Material compaction is the other major concern in both the storage compartment and feed systems. As the stored material is retrieved, its compressed bulk density will decrease, and a constant mass feed rate will be difficult to maintain.

Two major storage and retrieval systems that are presently used for RDF are the Atlas System and the Miller-Hofft System. The Atlas System works on a first-in, last-out concept; the Miller-Hofft System works in the first-in, first-out concept. Appendix A provides additional manufacturers and users information on these two types of storage systems.

The Doffing-Roll bin described in appendix A has design characteristics that make it a good interstage storage bin or prefeed mill, taking the refuse through the top of the bin while constantly agitating the storage mass with rooftop screws. The drag chain located on the floor of the bin then pulls the refuse mass to the feeder.

4.2 Combustion Subsystem. Spreader stoker boilers, and in particular the traveling-grate type, have the ability to burn fuels having a wide range of combustion characteristics, including fuel having high moisture and high ash content. For this reason co-firing of RDF and coal is generally appropriate for this type of stoker unit. Fuel size segregation, however, is a problem with any size of stoker. Size segregation, where fine and coarse fuel particles are not distributed evenly over the grate, produces a ragged fire resulting in poor conversion efficiency. For this reason, homogenized RDF fuel is more appropriate for co-firing with coal. An ideal spreader stoker boiler will have an evenly distributed fuel bed of 2 to 4 inches thick. Maximum design heat release rate of 450,000 to 750,000 Btu/ft²/hr is acceptable for such boiler units.

a. Ash Disposal Requirements

Traveling grate stoker units have no limits on maximum ash content of fuel. Traveling grate continuous ash discharge stokers generally have either a basement ash pit or elevation of the firing level to obtain the ash

storage space. Ashes are generally removed from ash pits for final disposal by means of a conventional ash-transport system such as a pneumatic (vacuum) conveyor or hydraulic sluicing systems. On coal-fired boilers, ash disposal systems are designed for intermittent or continuous operations. An ash disposal system consists of a means for removing ash from the furnace and loading it onto a conveyor system to storage and a means of disposing of stored ash. A hopper to deliver the furnace bottom ash can be directly discharged to ash cars or trucks for disposal in local landfills. For large boiler plants, hydraulic sluicing is generally an option for ash handling. Pneumatic ash conveyors have been especially developed for handling of both abrasive and fine dusty ash, flyash, and soot.

b. Air Pollution Control Requirements

Almost all coal-burning boiler plants require some kind of air pollution control equipment system. Air pollutants from a coal-burning boiler consists of particulates and gaseous emissions, such as SO_x , NO_x , trace metals, etc. The following are commonly used particulate removal equipment systems:

- Electrostatic precipitation (ESP).
- Fabric filter.
- Wet scrubber.
- Mechanical collectors (cyclones).

Appendix A provides information on collection efficiencies and benefits of the different equipment systems.

c. Establishing Retrofit Requirements

The extent of the retrofitting required to a stoker fired, coal-burning boiler equipment system, in order to successfully burn 100% RDF or RDF as supplemental fuel, will depend upon the following:

- Type of coal being burned.

- Type of stoker grate in the boiler.
- Combustion air supply system of the boiler.
- Induced draft fan capacity of boiler.
- Type of soot blowing in the tube banks.
- Existing ash handling system.
- Type of air pollution control device in the boiler plant.
- Type of furnace wall (waterwall or refractory wall).
- Superheater locations.
- Type of steam load demand and ratings.
- Boiler configuration to accommodate RDF firing scheme (peripheral appurtenances).
- Room for RDF storage handling, and firing schemes.
- Boiler combustion control system.

Considering all factors associated with the combustion of RDF as a fuel and the design of the Navy boilers, using 100% RDF in a retrofitted boiler is not recommended for the following reasons:

- A coal-burning combustion chamber will be too small to support 100% RDF. The RDF required to produce the same energy output takes longer to burn.
- Tube space will be inadequate for the passage of the high volume of combustion gases.
- The increase in ash product will likely overtax the ash handling equipment.
- The forced draft and induced draft fans will be inadequate to handle increased volume of combustion air and flue gases.
- The semisuspension firing of RDF will increase particulate loading to existing emission control system.
- Slagging of tubing will cause excessive downtime.

At the Ames Municipal Electric Power Company, experience shows that 50% RDF loading is attainable, although, 20 to 25% RDF has been found to be

preferred for long-term trouble-free operation. Therefore, it is recommended that usage of RDF be limited to 50% maximum.

Appendix A provides detailed data on operating requirements and design criteria for retrofitting the boilers to co-fire RDF and coal.

5.0 FIELD SURVEY DATA

One field visit was made to the Ames Municipal Electric Power Plant, Ames, Iowa to observe the only utility plant in the United States that has retrofitted stoker coal-fired boilers and uses RDF as a supplementary fuel. Operating data on the Ames, Iowa facility is discussed in section 4.1.1.1 and appendix A.

Site visits were also made to four naval installations to observe coal-fired boilers that might be candidates for co-fired considerations. The results of the visits to the naval installations are contained in appendix B.

6.0 ECONOMIC EVALUATION

6.1 General

Economic evaluations are presented in this section covering generic classes of boiler plant facilities ranging from two 50 MBtu/hr boilers to three 150 MBtu/hr boilers, and site specific boiler plant facilities considered to be technically feasible for co-firing RDF and coal. The site specific reviews will be limited to generalized evaluations based on site adapting designs developed to retrofit the generic classes of facilities.

The economic evaluation is based on the following parameters:

- a. The load factor per boiler was assumed to be equal to 0.75 based on 24 hour per day operations, 305 days per year, producing steam at 90% capacity.
- b. The economic life of the retrofitted boiler is 20 years.

c. The fuel mix will be maintained at 50% RDF and 50% coal as a function of energy input. The characteristics of RDF will be as specified in section 4.1.1.

d. Capital investment costs and O&M costs will be treated using a cost of capital of 10% and normal inflation, as outlined in the Economic Analysis Handbook, NAVFAC P-442, July 1980. The exception will be coal which will be treated as inflating at a rate of 2% faster than normal inflation.

e. Plant operations were considered to be unchanged with either the introduction or variance in usage of RDF.

f. Plant maintenance is varied to account for different levels of plant and equipment upkeep and increased equipment wear.

g. Boiler efficiencies are varied to account for different ages and conditions of boilers:

| | <u>100% Coal</u> | <u>Co-fired</u> | <u>100% RDF</u> |
|--------------------------|------------------|-----------------|-----------------|
| New Boiler (0-15 yrs) | 80% | 74% | 68% |
| Used Boiler (15-40 yrs) | 78% | 72% | 66% |
| Old Boiler (over 40 yrs) | 76% | 70% | 64% |

h. RDF costs are varied to reflect potential market conditions for RDF. Typical costs being experienced in the market today vary from \$15 to 35 per ton.

i. Boilers originally designed to burn coal will retain their full boiler ratings.

The life cycle cost analyses are presented in terms of:

- Cost curves developing Annual Fuel Cost Savings (AFCS) as a function of two variables: boiler efficiency and RDF price. The annual cost factor for capital investment and O&M costs are then developed and plotted against the annual fuel cost savings curves to determine the breakeven points and annual savings or loss to be derived from co-firing RDF and coal.

- Savings-to-investment ratios (SIR).
- Discounted payback periods.

Appendix C provides the complete economic evaluations for both the generic classes of boiler plant facilities and site specific boilers that technically qualify to co-fire RDF and coal.

6.2 MSW Processing Plant

One option considered within the study was to provide for a contractor owned and operated MSW processing plant to be erected within 1/2 mile of the Navy boiler plant.

The basic design provided for the proposed plant to produce RDF-2 fuel at a rate of 235 tons per day (single shift) or 470 tons per day (double shift), 5 days per week, 52 weeks per year. Annex I to appendix C provides a detailed description of the design concept, plant layout and cost factors. The plant would produce 61,000 tons per year of RDF-2 with a single shift operation or 122,000 tons per year with a double shift operation.

The capital investment cost to erect the MSW processing plant would equal:

- \$3.6 million for MSW processing equipment.
- \$4.3 million for facilities.

The MSW processing plant production costs including capital investment recovery, would equal:

- \$22.54 per ton (\$2.78 per MBtu) for the single shift operation.
- \$7.00 per ton (\$0.86 per MBtu) for the double shift operation.

Production cost projections are based on obtaining tipping fees and ferrous market revenues of \$15 per ton each.

6.3 Economic Model

The economic model is designed based on differential costs; i.e., the cost of the displaced fuel less the cost of the RDF must be equal to or greater

than the cost of the annual capital investment recovery charge plus the cost represented by changes in operations, maintenance, land usage, solid waste removal, administration, etc., for conversion to be cost effective.

6.4 Annual Fuel Cost Savings

The AFCS have been derived directly as a function of the cost of displaced fuel less the cost of the replacement RDF fuel. Appendix C contains the calculations, tables, and graphs depicting the annual fuel cost savings factors for the different boiler efficiencies, ratings, and RDF costs. Table 6-1 is an excerpt from appendix C for the average condition of operation; i.e., fully rated boilers operating with a co-firing efficiency of 72%.

As outlined in table 6-1 and annex C, major fuel cost savings could potentially be derived by converting to co-fired boilers, provided the boilers are in good operating condition and the proper modifications have been made to the boilers and plant. Annual fuel cost savings could range from \$0.1 to 3.5 million, for the average condition, dependent upon the plant size and cost of purchased RDF.

Table 6-1. Annual Fuel Cost Savings.
(Excerpt from Table C-3, Appendix C)

| RDF Price | | Annual Fuel Cost Savings | | | | |
|--|-----------|--|----------------|----------------|----------------|----------------|
| | | Boiler(s) Rated Output Capacity - 10 ⁶ Btu/Hour | | | | |
| (\$/Ton) | (\$/MBtu) | 100 (\$000) | 150 (\$000) | 200 (\$000) | 300 (\$000) | 450 (\$000) |
| <u>72% Co-firing Boiler Efficiency - No Derating</u> | | | | | | |
| 0 | 0 | 782 | 1,172 | 1,563 | 2,345 | 3,517 |
| 5 | 0.444 | 579 | 868 | 1,157 | 1,736 | 2,603 |
| 10 | 0.889 | 375 | 562 | 750 | 1,125 | 1,687 |
| 15 | 1.333 | 172 | 258 | 344 | 516 | 773 |
| 20 | 1.778 | (32) | (48) | (63) | (95) | (143) |
| 25 | 2.222 | (235) | (352) | (470) | (705) | (1,057) |
| 30 | 2.667 | (438) | (658) | (877) | (1,315) | (1,973) |

6.5 Design of Retrofitted Facilities

The boiler facility retrofits in the RDF receiving, storage, and charging systems used in the analyses, have been designed basically conforming with figure 4-5 and using the equipment recommended in appendix A.

The RDF storage system consists of two Atlas bins ranging from 350 ton capacity (for two 50 MBtu/hr boilers) to 2250 ton capacity (for three 150 MBtu/hr boilers).

6.6 Capital Investment Costs

Using the basic design scheme outline in section 4 and appendix A, capital investment costs have been derived based upon vendor quotations and estimates provided via a telephone survey. These costs are outlined in table 6-2.

6.7 O&M Costs

Supplemental O&M costs will be experienced annually in the operation and upkeep of the Navy boilers and RDF storage and delivery systems. These costs developed in appendix C, are restated in table 6-3.

6.8 Annual O&M and Capital Recovery Cost Factors

The annual capital investment recovery costs and O&M costs summarized in tables 6-2 and 6-3, when combined, must be equal to/or less than the AFCS if any real savings are to be realized.

Restating these costs from appendix C and applying maintenance variances, supplemental O&M and capital recovery costs would equal:

- 100 MBtu/hr plant (two 50 MBtu/hr boilers).

| | |
|---------------------|-----------|
| High Cost | \$527,809 |
| Probable Cost | 482,209 |
| Low Cost | 470,809 |

- 150 MBtu/hr plant (three 50 MBtu/hr boilers)

| | |
|---------------------|-----------|
| High Cost | \$610,499 |
| Probable Cost | 556,049 |
| Low Cost | 542,449 |

Table 6-2. Capital Investment Cost Summary
Navy Boiler Plant Modifications

| CAPITAL INVESTMENT COST CATEGORY | TOTAL RETROFITTED CAPACITY | | | | |
|-------------------------------------|--|--|---|---|---|
| | 100 MBtu/hr. (2-50 MBtu/hr. Boilers) | 150 MBtu/hr. (2-75 MBtu/hr. Boilers) | 200 MBtu/hr. (2-100 MBtu/hr. Boilers) | 300 MBtu/hr. (2-150 MBtu/hr. Boilers) | 450 MBtu/hr. (3-150 MBtu/hr. Boilers) |
| | (\$000) | (\$000) | (\$000) | (\$000) | (\$000) |
| 1. Primary Storage-Atlas Bins | \$1,400 | \$1,600 | \$1,865 | \$2,530 | \$3,800 |
| 2. Pneumatic Conveyor Sys. | 232 | 265 | 325 | 410 | 520 |
| 3. Boiler Modifications | 420 | 470 | 553 | 650 | 960 |
| 4. Soot Blower | 45 | 48 | 51 | 60 | 75 |
| 5. Process Control & Instru. | 80 | 85 | 94 | 110 | 130 |
| 6. Ash Handling Sys. | 110 | 122 | 136 | 160 | 185 |
| 7. Burner & Feed Mods | 130 | 150 | 170 | 200 | 280 |
| 8. Mech. & Elect. | 510 | 620 | 765 | 900 | 1350 |
| 9. Subtotal | 2,927 | 3,360 | 3,959 | 5,020 | 7,300 |
| 10. 10% Contingency | 293 | 336 | 396 | 502 | 730 |
| 11. Subtotal | 3,220 | 3,696 | 4,355 | 5,522 | 8,030 |
| 12. Engineering (8%) | 258 | 296 | 348 | 442 | 642 |
| 13. Total Costs | \$3,478 | \$3,992 | \$4,703 | \$5,964 | \$8,672 |

Note: Start up costs are included in the individual line item costs.

Table 6-3. O & M Supplemental Costs

| O & M COST CATEGORY | TOTAL RETROFITTED CAPACITY | | | | |
|-------------------------|--|--|---|---|---|
| | 100 MBtu/hr. (2-50 MBtu/hr. Boilers) | 150 MBtu/hr. (2-75 MBtu/hr. Boilers) | 200 MBtu/hr. (2-100 MBtu/hr. Boilers) | 300 MBtu/hr. (2-150 MBtu/hr. Boilers) | 450 MBtu/hr. (3-150 MBtu/hr. Boilers) |
| | (\$000) | (\$000) | (\$000) | (\$000) | (\$000) |
| 1. <u>Operations</u> | | | | | |
| <u>Utility Transfer</u> | | | | | |
| Electrical | \$ 3 | \$ 4 | \$ 4 | \$ 5 | \$ 7 |
| 2. <u>Maintenance</u> | | | | | |
| Labor | 10 | 12 | 14 | 21 | 30 |
| Material | 8 | 10 | 11 | 15 | 22 |
| Contracts | 30 | 35 | 40 | 58 | 84 |
| 3. Subtotal | 51 | 61 | 69 | 99 | 143 |
| 4. Administration | 6 | 7 | 8 | 12 | 16 |
| 5. Total | \$ 57 | \$ 68 | \$ 77 | \$111 | \$159 |

- 200 MBtu/hr plant (two 100 MBtu/hr boilers)

| | |
|---------------------|-----------|
| High Cost | \$713,574 |
| Probable Cost | 651,974 |
| Low Cost | 636,574 |

- 300 MBtu/hr plant (two 150 MBtu/hr boilers)

| | |
|---------------------|-----------|
| High Cost | \$928,940 |
| Probable Cost | 840,140 |
| Low Cost | 817,940 |

- 450 MBtu/hr plant (three 150 MBtu/hr boilers)

| | |
|---------------------|-------------|
| High Cost | \$1,346,411 |
| Probable Cost | 1,219,211 |
| Low Cost | 1,187,411 |

Note: Probable cost is defined as the mostly likely cost to be incurred based on anticipated maintenance costs. High and low costs are developed by varying maintenance and repair costs.

6.9 Break-even Point

The annual O&M and capital recovery cost factors have been plotted against the AFCS for varying boiler operating conditions in figures C-1 through C-5 of appendix C.

The five different generic cases analyzed in appendix C proved to be quite sensitive to different efficiency ratings and maintenance variances. This can be primarily attributed to the closeness of RDF and coal fuel costs per MBtu.

The break-even points for the five generic cases, as taken from appendix C, range from \$7.60 per ton (\$0.656 per MBtu) for two 50 MBtu/hr boilers, to \$12.56 per ton (\$0.986 per MBtu) for three 150 MBtu/hr boilers. These represent the values that an activity could afford to pay for RDF and still break-even. Specific break-even points include:

| <u>Retrofitted Capacity</u> | <u>Cost per Ton</u> | <u>Cost per MBtu</u> |
|-----------------------------|---------------------|----------------------|
| 100 MBtu/hr | \$ 7.60 | \$0.656 |
| 150 MBtu/hr | 10.13 | 0.770 |
| 200 MBtu/hr | 11.21 | 0.866 |
| 300 MBtu/hr | 12.34 | 0.967 |
| 450 MBtu/hr | 12.56 | 0.986 |

These break even points are based on normalized conditions; i.e., 72% boiler efficiency and probable capital recovery and supplemental O&M costs.

6.10 Case Studies

Two separate case studies are developed in annex II of appendix C to show the total parameters that can affect or influence the decision to convert a coal-fired boiler to co-fire RDF and coal. Table 6-4 summarizes the results of the case studies. Both cases integrated the use of a contractor owned and operated MSW processing plant located 1/2 mile from the Navy boiler plant.

Case number 1 assumed a single shift operation of the MSW processing plant resulting in a unit cost of RDF ranging from \$22.54 per ton to \$24.54 per ton. The net result was to expect major operating losses in excess of \$5 million over the 20-year life cycle.

Case number 2 assumed double shift operations of the MSW processing plant with a unit cost of RDF coming off the production line ranging from \$7.00 per ton to \$9.66 per ton. The net result was to expect savings of \$4 million over the 20-year life cycle with a SIR = 1.78. However, when the RDF utilization in the boilers was reduced from 50% to 25% of energy input, the savings turned to a major loss.

Table 6-4. Summary of Case Studies.

| | <u>Case #1</u> | <u>Case #2</u> |
|---|---|---|
| a. Retrofitted Boiler Capacity | 200 MBTU/hr (2-100 MBtu/hr boilers) | 300 MBtu/hr (2-150 MBtu/hr boilers) |
| b. Total RDF Required Per Year | 61,000 Tons | 122,000 Tons |
| c. MSW Processing Plant | | |
| (1) Capital Investment | \$7,403,949 | \$7,403,949 |
| (2) Annual Capital Investment Recovery Charge | 1,003,000 | 1,003,000 |
| (3) First 10-year Operations Annual RDF Production Cost Unit Cost of RDF | 1,375,000* 22.54/Ton | 854,000* 7.00/Ton |
| (4) Second 10-Year Operations Annual RDF Production Cost Unit Cost of RDF | 1,475,000* 24.18/Ton | 1,179,000* 9.66/Ton |
| d. RDF Storage, Conveyor, and Combustion Systems Capital Capital Investment Program | 3,872,000 | 5,963,760 |
| e. Retrofitted Boilers Operations (RDF/Coal) Net Present Cost (20-year Operations) | 42,619,000 | 56,915,000 |
| f. Fossil Fuel Boiler Operations (100% Coal) Net Present Cost (20-year Operations) | 36,932,000 | 61,100,000 |
| g. Savings (or Loss) | (\$5,687,000) | \$4,185,000 |
| h. Savings to Investment Ratio | -Loss | 1.78 |

NOTE: * Although Case #2 reflects a larger operation than Case #1, projected annual RDF production costs for Case #2 are lower due to increases in revenues exceeding increases in costs when going to the larger operation. Refer to annex II to appendix C for details.

6.11 Savings-to-Investment Ratio and Discount Payback Period

If RDF could be obtained at \$10 per ton in terms of 1983 dollars, then the SIR and discounted payback period would equal:

| <u>Generic Case Retrofitted Boiler Capacity (MBtu/hr)</u> | <u>SIR</u> | <u>Discounted Payback Period</u> |
|---|------------|--|
| 100 | 0.75 | 20.0 years (+) |
| 150 | 1.01 | 20.0 years |
| 200 | 1.17 | 13.8 years |
| 300 | 1.39 | 10.0 years |
| 450 | 1.44 | 9.3 years |

These SIR and discounted payback factors are based upon normalized operations; i.e., each boiler is at full rating and operates in the co-fired mode at 72% efficiency, 90% capacity, 24 hours per day, 305 days per year.

6.12 Site Specific Reviews

Six Naval installations either currently fire or will fire coal, and are considered to be technically suitable for converting to co-fired RDF and coal.

Using the generic designs and costs outlined in appendix C, the estimated O&M cost savings (AFCS-added O&M costs) and SIR for each site specific station, based on an RDF costs of \$10 per ton, would equal:

| <u>Station</u> | <u>Annual O&M Savings</u> | <u>SIR</u> |
|------------------------|-------------------------------|------------|
| NPWC Norfolk, VA | \$0.72 million | 1.40* |
| NAB Little Creek, VA | 0.33 million | 0.60 |
| NAVORD Indian Head, MD | 0.47 million | 0.57 |
| MCAS Cherry Pt., NC | 0.42 million | 0.76 |
| Puget Sound NSY, WA | 0.50 million | 0.73 |
| Bremerton Sub Base, WA | 0.08 million | 0.33 |

NOTE: * Reflects RDF-3 with a high heat value 17% higher than RDF-2.

One principal problem experienced at all stations, with the exception of NPWC Norfolk, is the lack of sufficient demand load to support the boiler plant operational requirement of 90% capacity, 305 days per year. In many cases, boilers would operate at 50 or 60% of capacity and the annual fuel cost savings of coal would be reduced substantially.

Evaluating NPWC Norfolk individually, if the price of RDF-3 in Norfolk amounted to \$15 per ton vice \$10, the net annual O&M savings would drop to \$0.34 million and the SIR would drop to 0.66. The probability of obtaining RDF-3 at \$10 per ton is remote when RDF-3 costs are typically running nationally between \$15 and \$30 per ton.

Appendix C provides more detailed analysis of each of the site specific cases.

6.13 Critical Cost Parameters

The capital cost factors surrounding the selection of the MSW plant equipment are too numerous to make any guideline predictions. Additional work would be needed to evaluate different types of equipment and size of plants. Cost parameters should anticipate a double-shift operation, however, in order to defer the capital cost over a wider production base. For the size of operations evaluated in this report, the MSW plant should be designed to produce RDF at a unit cost of \$12.39 per ton (or less) to maintain an SIR = 1.0.

The capital cost parameters surrounding the RDF storage, delivery, and combustion subsystems could favor retrofitting three or more boilers in order to guarantee consumption of the RDF produced by a double-shift operation at the MSW processing plant. A reduction in demand could significantly affect the unit price of RDF. The storage system should provide a 3-day supply. In this evaluation, the most economical design for the three subsystems was at \$0.60 per ton of RDF burned.

The MSW processing plant O&M costs have three critical factors to consider, (1) the tipping fee revenues, (2) the availability of a market for ferrous metals, and (3) the decision to repair or replace equipment during the second 10 years of operation.

Tipping fee costs should average \$15 per ton or more. Any reduction below this figure would increase the unit cost of RDF sold by \$0.84 for every dollar reduction in tipping fee.

The absence of a market for ferrous metals could have a net effect of increasing the unit price of RDF by \$0.82 per ton.

Repairs versus replacement of equipment decisions in the MSW Processing Plant must be carefully studied. If replacement costs exceed repair costs by more than 50% in terms of net present cost, a significant impact may be experienced increasing the RDF unit cost by \$0.70 to \$1.40 per ton. Some specific MSW processing plant O&M cost parameters used in the industry include:

- Plant operations will normally include 1 supervisor and 4 to 10 workers per shift dependent upon plant size.
- Maintenance labor will normally average 1 to 7 people dependent upon plant size, age, and numbers of shifts of operations.
- Maintenance materials and supplies will equal between 2% to 4% of capital investment cost dependent upon plant size, age, and type of operation.
- Plant supervision is estimated to be 15% of plant operational labor.
- Administrative labor is estimated at 10% of supervisory and direct labor.
- Payroll burden equals 31% of total labor.
- General insurance equals 0.5% of capital investment.
- Taxes are estimated at 2% of capital investment.
- General Overhead and Administration (G&A) is estimated at 2% of capital investment.

The Navy boiler plant operations and maintenance programs will be affected by four critical factors. The load factor if reduced below 24 hours per day, 305 days per year, 90% of capacity operation, can significantly impact plant profit/loss statements. Secondly, maintenance programs at the plant could increase by a factor of \$0.90 to \$1.85 per ton of RDF burned dependent upon age of the RDF support equipment and boiler retrofits. Third, plant demand for RDF could significantly impact the unit price if consumption drops below 50%. In general, consumption must be maintained at 40% RDF or above. The fourth factor, the unit cost of coal, can have a major impact on the price that the Navy is willing to pay for RDF. For example, in the Norfolk, VA area, coal sells for \$41 per ton, in Charleston, SC - \$43 per ton, in Great Lakes, IL - \$50 per ton, and in Bremerton, WA - \$36.50 per ton. One dollar above or below \$42 per ton for coal, as used in these case studies and analyses, would raise or lower the affordable price of RDF by \$0.40 or more per ton.

One final factor that can significantly impact on the economics of the decision to convert to RDF, is the selection of discount factors. In these case studies, all capital investment and O&M costs were projected at the standard 10% cost of capital rate with the exception of coal. Coal was projected to inflate at a rate 2% faster than normal inflation. As a result, the +2% differential cumulative discount factor was used for determining Net Present Value Cost of coal.

7.0 NAVY BOILER PLANTS

7.1 Coal-Fired Boilers

7.1.1 General. An evaluation was made of the Navy inventory of boilers with 50 MBtu/hr capacity or greater. The evaluation was based upon data provided in the Department of Energy Federal Facilities Fuel Use Act Status Report and field surveys.

7.1.2 Coal as a Primary Fuel. The Navy currently has nine installations either using coal as a primary fuel or in the process of converting boilers over to coal as the primary fuel. These activities include:

- Norfolk Navy Public Works Center
One Riley, 220 MBtu/hr boiler
- MCAS Cherry Point
Two Keeler, 95 MBtu/hr boilers
- NAB Little Creek
Three Wickes, 100 MBtu/hr boilers
- Charleston Naval Shipyard
Five Babcock Wilcox, 65 MBtu/hr boilers
- Quantico MCDEC
Two Combustion Engineering, 61 MBtu/hr boilers
One Riley Stoker, 61 MBtu/hr boiler
One Riley Stoker, 146 MBtu/hr boiler
- Indian Head Naval Ordnance Center
Three Combustion Engineering, 165 MBtu/hr boilers
- MCB Camp LeJeune
Four Riley Stoker, 114 MBtu/hr boilers
- Bremerton Sub Base
Two Keeler, 60 MBtu/hr boilers
- Puget Sound Naval Shipyard
The Puget Sound main boilers in building 106 are being replaced under MCON Project P500 with three new 150 MBtu/hr coal-fired boilers with RDF capabilities.

7.1.3 Coal as a Secondary Fuel. Two activities within the Navy use coal as a secondary fuel. These activities include:

- Norfolk Naval Shipyard
Three Combustion Engineering, 150 MBtu/hr boilers
Three Riley Stoker 150 MBtu/hr boilers
Note: These boilers are being decommissioned in 1988 when the new refuse derived fuel plant is completed.
- Norfolk Navy Public Works Center
Three Combustion Engineering, 100 MBtu/hr boilers
One Combustion Engineering, 115 MBtu/hr boiler

7.2 Technical Evaluation

Of the 27 boilers firing coal as a primary fuel, 10 are recommended for economic evaluation for possible conversion to co-fire RDF and coal. The remaining 17 boilers are not recommended for the following reasons:

- NAB Little Creek
One Wickes, 100 MBtu/hr boiler
Note: One boiler is required to be held in standby.
- Charleston Naval Shipyard
Five Bobcock Wilcox, 65 MBtu/hr boilers
Note: Boilers are overaged
- Quantico MCDEC
Two Combustion Engineering, 61 MBtu/hr boilers
One Riley Stoker, 61 MBtu/hr boiler
One Riley Stoker, 146 MBtu/hr boiler
Note: Boilers are overaged
- Indian Head Naval Ordnance Center
One Combustion Engineering, 165 MBtu/hr boiler
Note: One boiler is required to be held in standby
- MCB Camp Lejuene
Four Riley Stoker, 114 MBtu/hr boilers
Note: Boilers are overaged
- Bremerton Sub Base
One Keeler, 60 MBtu/hr boiler
Note: One boiler required to be maintained in standby
- Puget Sound Naval Shipyard
One 150 MBtu/hr boiler
Note: One boiler required to be maintained in standby

The 10 boilers firing coal as a secondary fuel all exceed the 30-year age criteria and, therefore, are not recommended for conversion.

The usage of a 30-year criterion for maximum age of boilers to be considered, based on a 1983 baseline, appears well founded. Of the 13 boilers listed as overaged, 12 are World War II vintage or earlier. From the field visits made, the condition of this vintage boiler appears marginal for co-firing RDF and a coal now. If a boiler of this age was selected for conversion,

approximately 3-5 more years would have to be added before the physical conversion would be realized via the Military Construction (MCON) program. Adding 20 years for the projected life of the converted boilers, the Navy plants would have to last 60 to 65 years before retirement, 20 of those years burning RDF with all the firing and slagging problems identified with RDF.

7.3 Economic Evaluation

Of the 10 active boilers listed with a rated capacity of 50 MBtu/hr or greater and having the technical characteristics considered suitable for co-firing RDF and coal, none appear to possess economic possibilities for further consideration. Section 6.12 contains specific economic factors associated with each site specific consideration.

8.0 CONCLUSIONS AND RECOMMENDATIONS

8.1 General

Spreader stoker boilers are designed to burn fuels having a wide range of combustion characteristics. Normally, this type of boiler will support the co-firing of RDF-2 and coal, however, due to design limitations, retrofitting this type of boiler for firing 100% RDF is not recommended for the following reasons:

- A coal-burning combustion chamber will be too small to support 100% RDF. The RDF required to produce the same energy output takes longer to burn.
- Tube space will be inadequate for the passage of the high volume of combustion gases.
- The increase in ash product will likely overtax the ash handling equipment.
- The forced draft and induced draft fans will be inadequate to handle combustion air and flue gases.
- The semisuspension firing of RDF will increase particulate loading to existing emission control system.
- Slagging of tubing will cause excessive downtime.

At the Ames Municipal Electric Power Company, experience shows that 50% RDF loading is attainable although 20 to 25% RDF has been found to be preferred for long-term, trouble-free operation. Therefore, it is recommended that any consideration for usage of RDF be limited to 50% of energy output, maximum.

Retrofitting a stoker boiler to co-fire 50% RDF-2/50% coal, will impact significantly on boiler plant operations including:

- a. Reducing boiler efficiency because RDF has a lower heating value than coal.
- b. Increasing fuel gas moisture losses due to the higher moisture content in the RDF.
- c. Decreasing combustion efficiency by requiring more excess air for combustion (40% for RDF versus 20% for coal).
- d. Increasing bottom ash loading requirements.
- e. Decreasing coal usage providing the incentive for RDF.

As a result, major modifications to the boiler plant will be required including:

- Installation of RDF storage and retrieval system.
- Addition of fuel firing nozzles, overfire air and grate underfire air system, and associated feed system and controls.
- Increasing the ash handling and disposal facility.
- Increasing air pollution control device capacity.
- Increasing the capabilities of forced and indirect draft fans.

The allowable cost of RDF based on the break-even points for the five generic cases of boiler installation, as outlined in section 6.9 for a 50% RDF/50% coal mix, will range from \$7.60 per ton (\$0.656 per MBtu) for two 50 MBtu/hr boilers, to \$12.56 per ton (\$0.986 per MBtu) for three 150 MBtu/hr boilers. Specific break-even points include:

| <u>Retrofitted Capacity</u> | <u>Cost per Ton</u> | <u>Cost per MBtu</u> |
|-----------------------------|---------------------|----------------------|
| 100 MBtu/hr | \$ 7.60 | \$0.656 |
| 150 MBtu/hr | 10.13 | 0.770 |
| 200 MBtu/hr | 11.21 | 0.866 |
| 300 MBtu/hr | 12.34 | 0.967 |
| 450 MBtu/hr | 12.56 | 0.986 |

Taking a norm of \$10 per ton for RDF and evaluating each generic case, the SIR and discounted payback period would equal:

| <u>Generic Case Retrofitted Boiler Capacity (MBtu/hr)</u> | <u>SIR</u> | <u>Discounted Payback Period</u> |
|---|------------|--|
| 100 | 0.75 | 20.0 years (+) |
| 150 | 1.01 | 20.0 years |
| 200 | 1.17 | 13.8 years |
| 300 | 1.39 | 10.0 years |
| 450 | 1.44 | 9.3 years |

8.2 Conclusions

The Navy inventory of 149 active boilers located at 35 Naval installations, with rated capacities of 50 MBtu/hr or greater, currently includes:

- 27 boilers firing coal as a primary fuel.
- 10 boilers firing coal as a secondary fuel.

Of the 37 boilers that fire coal as a primary or secondary fuel, 23 (or 62%) are over 30 years old and are not recommended for conversion. Four of the remaining 14 boilers would be required to be held in standby, firing fossil fuel only, leaving a total of 10 boilers available for economic evaluation.

Using the generic designs and costs outlined in section 6 and appendix C, the estimated O&M cost savings (AFCS-added O&M costs) and SIR for each site specific station housing one or more of the 10 eligible boilers, based on an RDF costs of \$10 per ton, would equal:

| <u>Station</u> | <u>Annual O&M Savings</u> | <u>SIR</u> |
|------------------------|-------------------------------|------------|
| NPWC Norfolk, VA | \$0.72 million | 1.40* |
| NAB Little Creek, VA | 0.33 million | 0.60 |
| NAVORD Indian Head, MD | 0.47 million | 0.57 |
| MCAS Cherry Pt., NC | 0.42 million | 0.76 |
| Puget Sound NSY, WA | 0.50 million | 0.73 |
| Bremerton Sub Base, WA | 0.08 million | 0.33 |

NOTE: * Reflects RDF-3 with a high heat value 17% higher than RDF-2.

One principal problem experienced at all stations, with the exception of NPWC Norfolk, is the lack of sufficient demand load to support the boiler plant operational requirement of 90% capacity, 305 days per year. In many cases, boilers would operate at 50 or 60% of capacity and the annual fuel cost savings of coal would be reduced substantially.

Evaluating NPWC Norfolk individually, if the price of RDF-3 in Norfolk amounted to \$15 per ton vice \$10, the net annual O&M savings would drop to \$0.34 million and the SIR would drop to 0.66. The probability of obtaining RDF-3 at \$10 per ton is remote when RDF-3 costs are typically running nationally between \$15 and \$30 per ton.

Based on the evaluations, none of the 10 remaining boilers are recommended for conversion to co-fired RDF and coal operations.

8.3 Recommendations

In view of the age of Navy coal-fired boiler inventory, it is recommended that future RDF considerations be aligned towards analyzing the replacement of overaged facilities with either mass burning solid waste plants or dual fired refuse derived fuel/coal plants.

REFERENCES

1. Utilization of Refuse Derived Fuels by Electric Utilities, Section 3, Combustion of Refuse Fuel, ERPI, Palo Alto, CA, November 1977.
2. Resource Recovery Plant Implementation Guides for Municipal Officials Technology, Report No. PB-259-144, EPA, Cincinnati, OH, 1976.
3. Technology Assessment: Municipal Solid Waste as a Utility Fuel, Report No. CS-2409, EPRI, Palo Alto, CA, July 1982.
4. Even, J., et al, Evaluation of Ames Solid Waste Recovery System, Report No. 600-2-77-205, Part 1, EPA, Cincinnati, OH, November 1977.
5. New Orleans Resource Recovery Facility - Implementation Study, National Center for Resource Recovery, Inc., Washington, D.C., September 1977.
6. Municipal Solid Waste, Fifth Annual Research Symposium, EPA Municipal Environmental Research Laboratory, Orlando, FL, March 1979.
7. Tchobanoglous, G., et al, Solid Wastes, McGraw-Hill Book Co.
8. Magnetic Separation: Recovery of Saleable Iron and Steel from Municipal Waste, Report No. PB-266-114, EPA, Cincinnati, OH, March 1977.
9. Industrial Solid Waste Disposal, Environmental Handbook Series, Pollution Engineering.
10. Chatterjee, A. K., Technical, Environmental and Economic Evaluations of the San Diego County Resource Recovery Facility at El Cajon, CA, Contract No. 68-01-4420, EPA, Washington, D.C., April 1979.
11. Trezek, G. J., Significance of Size Reduction in Solid Waste Management, Report No. 600-2-77-131, EPA, Cincinnati, OH, July 1977.
12. Catalog from Saturn Shredder Co.
13. Fuels from Municipal Refuse for Utility Technology Assessment, Report No. 261-1, EPRI, Palo Alto, CA, March 1975.
14. Lisiecki, H., RDF Storage and Retrieval Problems -- Cause, Effect, and Options, ASME Proceedings of the Eighth National Waste Processing Conference, Chicago, IL, May 1978.
15. Hickman, W., Storage and Retrieval of Prepared Refuse, ASME Proceedings of the Sixth National Waste Processing Conference, Boston, MA, May 1976.
16. Communicaton with Atlas System Corporation.
17. Gaffert, Steam Power Stations, 3rd Edition, McGraw Hill Book Co.

18. Steam -- Its Generation and Use, Babcock and Wilcox.
19. Rochford, R., and S. Wilkowski, Considerations in the Design of a Shredded Municipal Refuse Burning and Heat Recovery System, ASME Proceedings of the Eighth National Waste Processing Conference, Chicago, IL, May 1978.
20. Refuse Fired Energy Systems in Europe -- An Evaluation of Design Practices: An Executive Summary, Report No. SW-771, EPA, Washington, D.C., November 1979.
21. Shater, C. and T. F. Robinson, Techniques of Solid Waste Fuel Combustion, ASME Paper No. 79, IPC-Pwr-3, July 1980.
22. Vaughan, D., et al, Handling and Cofiring of Shredded Municipal Refuse and Coal in a Spreader Stoker Boiler, ASME Proceedings of the Eighth National Waste Processing Conference, Chicago, IL, May 1978.
23. Communication from Mr. Arthur Chantland, Director, Public Works Department, Ames, IA.

APPENDIX A
DESIGN PARAMETERS

A.1 GENERAL

The concepts and the design parameters required to support the utilization of RDF in stoker, coal-fired boilers are explored and outlined in this appendix for the following areas:

- Processing subsystem
- Transport subsystem
- Storage subsystem
- Retrieval subsystem
- Combustion subsystem

A.2 PROCESSING SUBSYSTEMS

Figure A-1 provides a flow diagram of a MSW processing plant to produce RDF-2 fuel. The characteristics of the major MSW processing train components required to support the flow diagram are detailed in the following sections.

A.2.1 Truck Scale

The function of the truck scale is to obtain an accurate weight of refuse received at the processing facility. The equipment system consists of a concrete weighing platform and a weighing and recording mechanism. Most of the truck scales used in refuse processing plants meet all applicable accuracy and tolerance requirements of the National Bureau of Standards Handbook No. 44. In order to be approved by the city, state, and National Bureau of Standards, the scale system will have to be capable of maintaining accuracy within 0.2%.

There are various types of truck scales employed in MSW processing facilities. The truck scale system range from a simple manual type to a type with complex computer-controlled display, record, and data compilation capability.

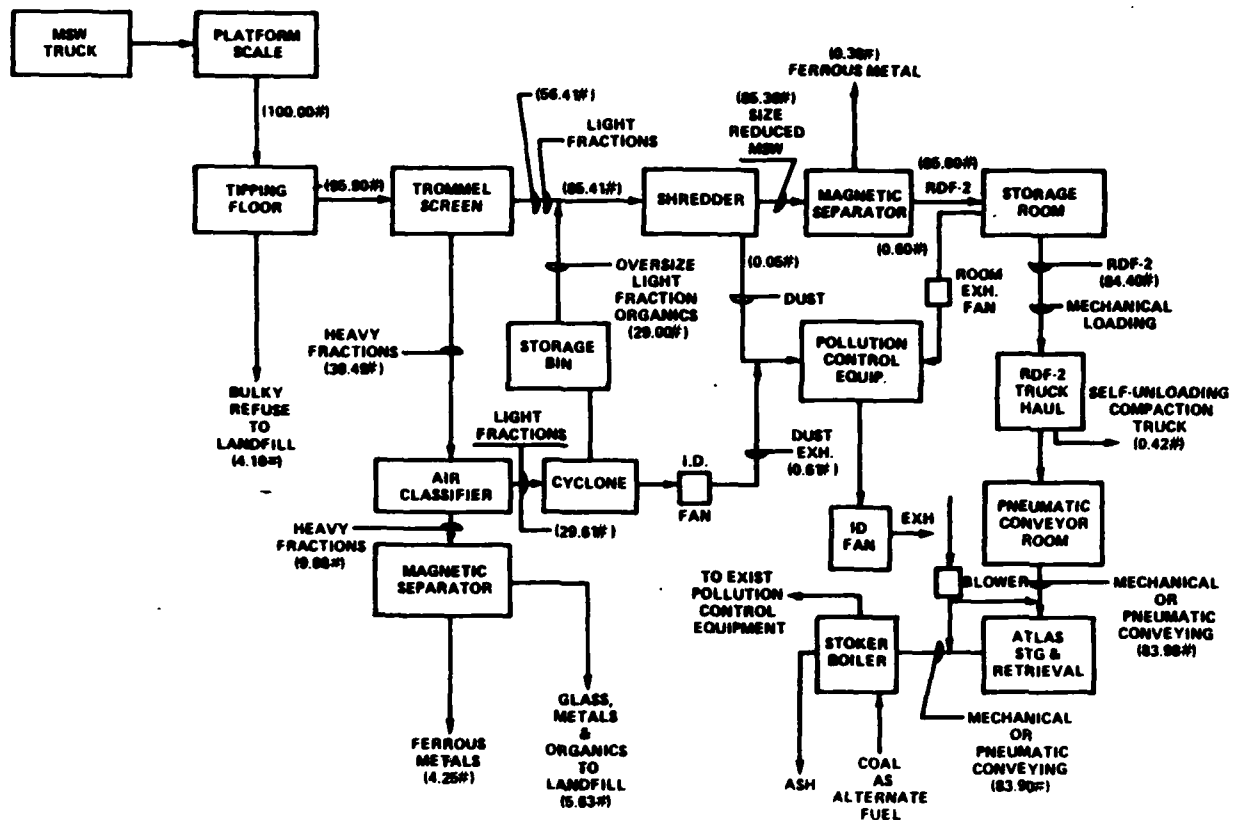

Figure A-1. Flow Diagram of an MSW Processing Plant to Produce RDF-2 Fuel.

Normally the platform scale is approximately 10 feet wide by 70 feet long and has a capability of 50 tons. The operation of the truck scale generally is as follows. The refuse truck driver parks the loaded truck over the platform scale. The truck driver or the attending scale room operator then inserts an identification card, specifically prepared for that truck, in the card reader of the scale. The card reader records and stores the following data:

- Date and time the specific truck was weighed.

- Truck sequential I.D.
- The driver I.D.
- Tare weight of the truck.
- Gross weight of the truck.
- Net weight of the refuse in the truck.

A printout of the above data is generally provided to the truck driver, and the scale room attendant generally keeps one copy of the record for the monthly billing. The machine logs daily loads of refuse coming to the facility and, at the end of each day, prints out the total weight of the refuse received at the plant.

Potential suppliers of the truck scale are:

- Fairbanks-Morse Weighing, Division of Colt Industries.
- Toledo Scale.
- Richardson Scale.

A.2.2 Screening

Screening is employed to separate a mixture of materials of different sizes into two or more portions by means of one or more screening surfaces. The screens function as "go" or "no-go" gages. Screening of solid wastes has been used extensively to produce fluff RDF. The most common application of screens has been to separate the crushed metals and glass from the shredded and air classified refuse.

Common types of screens that have been employed in the solid waste processing industry are:

- Vibrating screen.
- Rotary drum or trommel screen.
- Disc screen.

Trommel screens are used on both processed (shredded) and unprocessed raw MSW.

Vibrating Screen. The vibrating screens work well when the materials to be screened are dry, shredded, air classified, and magnetically separated. The vibrating screens have not been very reliable in the separation of glass particles from shredded refuse; they have a tendency to stratify the refuse material. Many vibrating screens are composed of multilayer screens with different hole sizes.

Trommel Screen. A typical trommel screen is illustrated in figure A-2. The trommel screen consists of a rotating cylindrical screen. The screening plate is fabricated from 5/8-inch to 3/4-inch thick carbon steel plate with round holes of appropriate size. The trommel screens may have holes of a single diameter or of multiple diameters. The length and diameter of the screen will vary to achieve a desired percentage recovery. When the trommel screen is located ahead of the shredder, holes of a single diameter are generally provided for the screen. For the Recovery-1 facility in New Orleans, such a screen was provided with 4-3/4-inch diameter holes. The trommel unit is 10-1/2 feet in diameter by 45 feet long. The round holes have lower susceptibility to clogging. This trommel was designed to handle 62.5 TPH of unprocessed MSW. The unit is powered by a 40 hp motor. The base is constructed so that the trommel screen cylinder is provided with a 5-degree slope which aids the forward travel of the raw MSW. In many designs, manually adjustable lifters are provided so that field adjustment of the slope of the screen can be made to suit the specific type of MSW. The trommel is normally equipped with a variable speed drive unit. The speed of rotation (8-12 rpm) and the angle of inclination are adjusted to provide the tumbling action required to break the refuse bags and achieve the desired screening. The inside of the trommel cage is sometimes provided with spikes or lifters for tearing the plastic refuse bags.

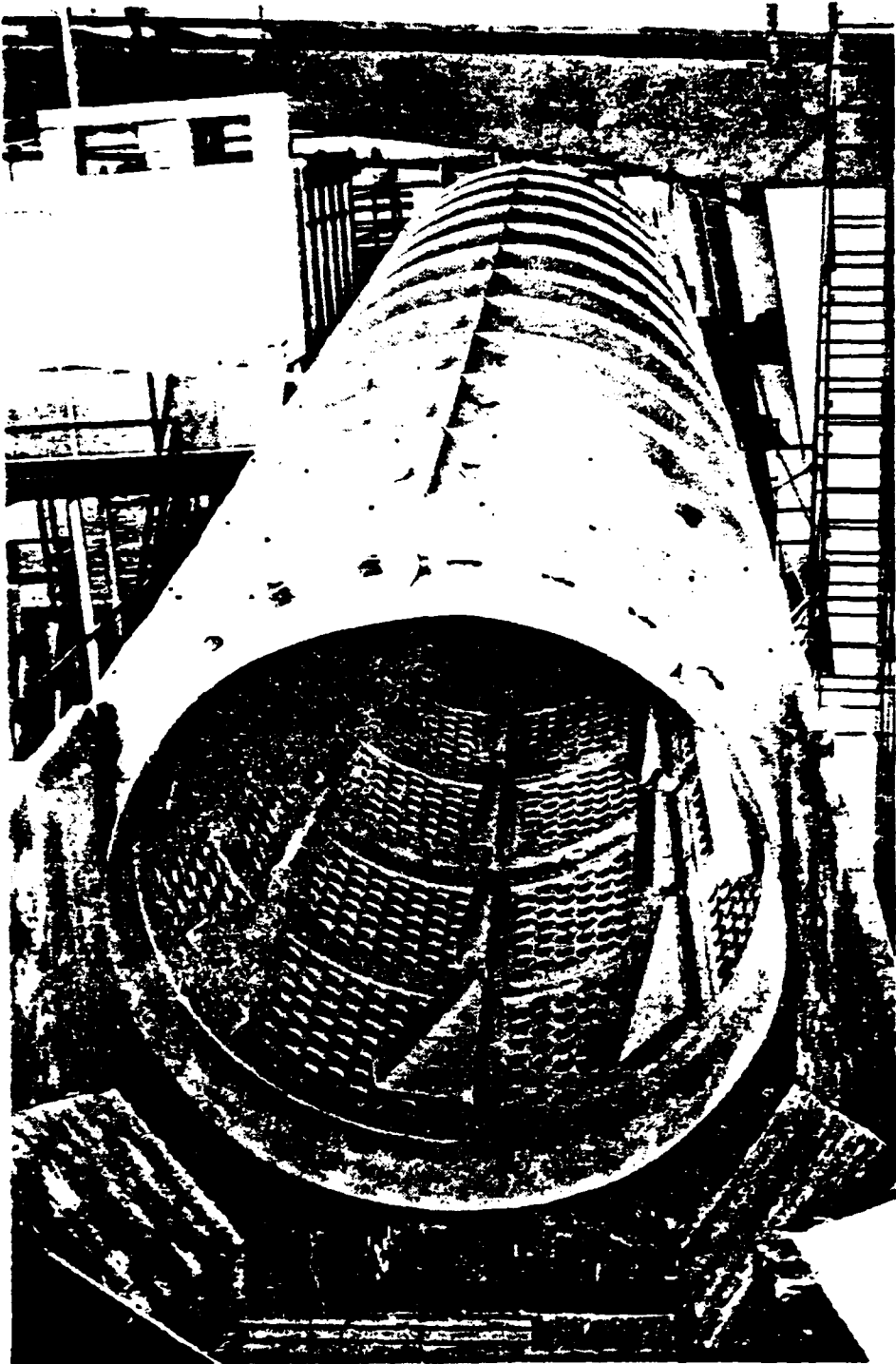

Figure A-2. Trommel Screen⁵.

Field tests on trommel screens with raw MSW has shown that most of the plastic refuse bags were broken in the tumbling action of the trommel, thereby liberating the bagged refuse; no serious binding of the screen occurred⁶. Test data on the trommel screen is shown in table A-1. Field tests show that more than 90% of the glass and 70% of the cans will pass through the 4-3/4 inch diameter holes of the screen. On an overall basis, 40% of the feedstock will pass through the holes and 60 percent of the MSW load will go to the primary shredder⁷.

Table A-1. Trommel Fraction Composition⁶.
(Wet Weight or "As-Received" Basis)

| Component | Underflow (%) | | Overflow (%) | | Calculated Infeed (%) | |
|----------------------|---------------|-------|--------------|-------|-----------------------|-------|
| | Run 1 | Run 2 | Run 1 | Run 2 | Run 1 | Run 2 |
| Mass split | 58.2 | 54.7 | 41.8 | 45.3 | | |
| Paper products | 12.0 | 28.5 | 47.6 | 69.4 | 26.9 | 47.0 |
| Yard waste | 14.9 | 6.9 | 2.6 | 7.1 | 9.8 | 7.0 |
| Plastics | 2.1 | 2.6 | 4.5 | 5.2 | 3.1 | 3.7 |
| Other heavy organics | 10.7 | 11.3 | 40.8 | 9.9 | 23.2 | 10.7 |
| Ferrous metals | 3.7 | 7.3 | 3.2 | 6.6 | 3.5 | 7.0 |
| Aluminum | 0.5 | 1.1 | 0.1 | 1.1 | 0.3 | 1.1 |
| Other nonferrous | 0.1 | 0.2 | 0.0 | 0.0 | 0.1 | 0.1 |
| Glass | 24.2 | 28.3 | 0.4 | 0.3 | 14.3 | 15.6 |
| Stones and ceramics | 5.7 | 2.3 | 0.0 | 0.0 | 3.3 | 1.2 |
| Minus 1/4" fines | 26.2 | 11.6 | 0.9 | 0.4 | 15.6 | 6.5 |

When a trommel unit receives the shredded heavy fractions of the air classified refuse, the screen plate of the trommel is provided with different diameter holes. For example, the trommel screen used for the San Diego County

resource recovery unit had a 1/2-inch diameter screen in the feed end of the screen, followed by a 4-inch diameter screen. Ground glass escapes through the 1/2-inch diameter holes, while tin cans and most metal and wood pieces pass through the 4-inch diameter holes.

In the Milwaukee resource recovery facility, a two-drum trommel screen was installed. The first 12 feet of the inner drum has 1-1/2-inch diameter openings and the last 8 feet of the inner drum has 4-inch openings. The outer drum, which is 12 feet long, is provided with 3/8-inch diameter holes. The feed of this trommel unit is obtained from the heavy fraction of the air-classifier. Four different size fractions of the feed stocks were prepared in the trommel screen of the Milwaukee resource recovery facility.

- Plus 4-inch material was to be landfilled.
- Minus 4-inch and plus 1-1/2-inch feed stock was to be processed for aluminum recovery.
- Minus 1-1/2-inch and plus 3/8-inch materials were to be processed for glass recovery.
- Minus 3/8-inch material was to be landfilled.

In the Ames, IA solid waste facility, a Radar disc screen was used.

Disc Screens. Properly sized and located, the disc screen can eliminate the troublesome glass and grit that adhere to refuse derived fuel. Disc screens are nonbending and highly efficient. They are readily adaptable to most plant layouts because of their compactness, low horsepower requirements, and high throughput.

Screen Selection. In the selection of the screening unit, the following factors must be considered:

- Characteristics of the refuse to be screened. This includes particle size, shape, bulk density, moisture content, and rheological properties.
- Screen type, vibrating or cylindrical

- Screen design characteristics such as materials of construction, hole shape (round or square) and size, total screening surface area, rotational speed of the drum (for cylindrical screen), oscillation rate (for vibrating screen), and loading rate.
- Separation efficiency desired and overall effectiveness of the screen.
- Operating characteristics such as energy requirement, complexity of design, complexity of operation, reliability, noise, and emissions (air and water).
- Site and space considerations to accommodate a given diameter and length screen.

The recovery efficiency of a screen can be expressed to indicate the percentage recovery of the material in the feed stream. Thus:

$$\% \text{ recovery} = AB/CD$$

Where A = weight of material escaped through holes
 B = weight fraction of material of desired size in underflow
 C = weight of material fed to the screen
 D = weight fraction of the material in the feed

For example, if glass content of MSW is 8%, total feed rate is 100 TPH, weight of underflow is 10 TPH, and glass content in the underflow is 7.2 TPH or 72% of the underflow:

$$\text{Recovery} = \frac{10 \times 0.72}{100 \times 0.08} \times 100 = 90\%$$

The effectiveness of a screen can be expressed

$$\text{Effectiveness (E)} = \text{Recovery} \times \text{Rejection}$$

where

$$\text{Rejection} = 1 - \text{recovery of undesired material}$$

$$= 1 - \frac{A(1-B)}{C(1-D)}$$

For the example problem, effectiveness is determined as

$$E = 0.9 \left[1 - \frac{10(1-0.72)}{100(1-0.08)} \right] = 0.87$$

Potential suppliers of the trommel screen are:

- Triple/S Dynamics
1031 S. Haskell
Dallas, TX 75223
- Radar Resource Recovery System
5350 Poplar Ave., Suite 320
Memphis, TN 38117
- Gruendler Crusher and Pulverizer Co.
- Pennsylvania Crusher Corporation

A.2.3 Magnetic Separator

Magnetic separation is perhaps the simplest of the unit operation processes for recovery of salable materials from MSW. Magnetic separation utilizes the magnetic properties of iron and steel which allows them to be removed from the MSW stream with a simple magnet⁵.

There are three types of magnetic separators commercially available⁶:

- Belt magnet.
- Drum magnets.
- Magnetic pulley.

All three types of separators are available either with permanent type magnets or as electromagnets.

Overhead belt magnetic separators and magnetic drum and pulley separators are shown in figure A-3 and A-4 respectively. Since a magnetic drum operates as a scalping device, small pieces of magnetic materials buried under a thick layer of shredded MSW will not be picked up. Similarly, those pieces which are partly ferrous, or otherwise have poor magnetic properties, are seldom picked up by a drum magnet. Proponents of the drum magnets, therefore, sometimes use a dual drum magnetic separator as shown in figure A-5. Dual drum separators improve the purity of the ferrous stock separated from the feed materials. In a dual drum separator, the majority of the ferrous metals is

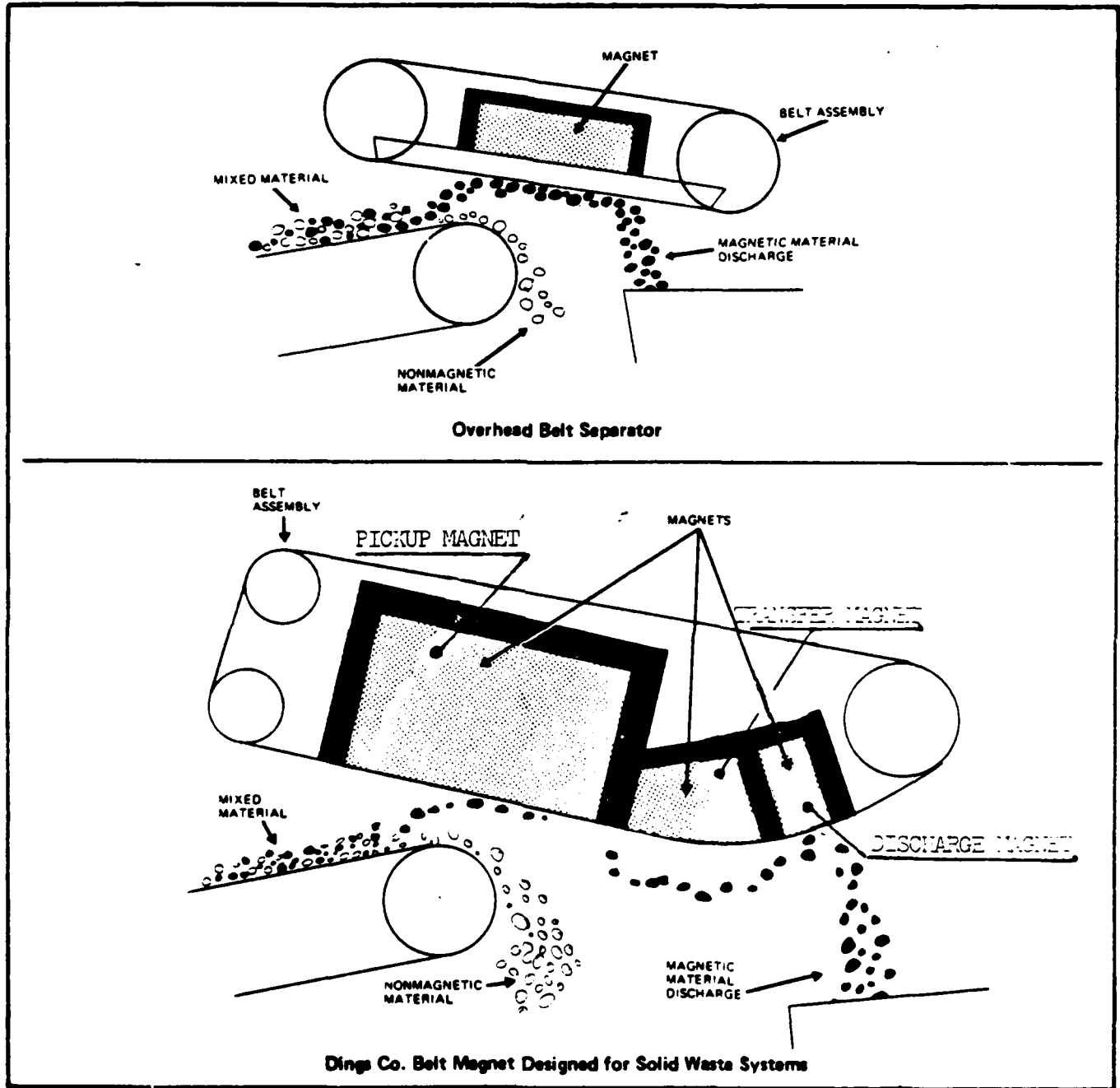

Figure A-3. Overhead Belt Magnetic Separators⁵.

picked up by the first drum; the second drum's magnet can then be smaller. To prevent jamming or bridging from occurring, the second drum of the two-drum magnetic separator rotates in a direction opposite to the flow of material (figure A-5).

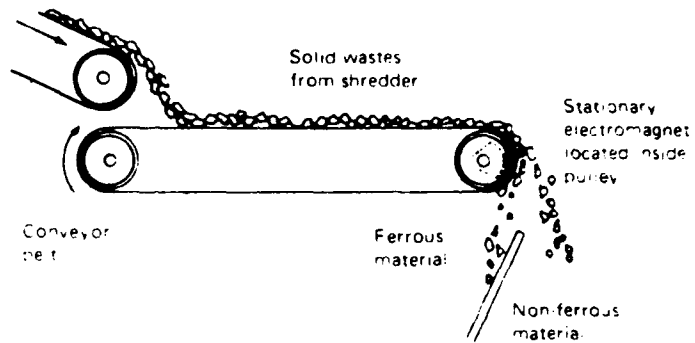

Figure A-4. Magnetic Pulley Separator⁷.

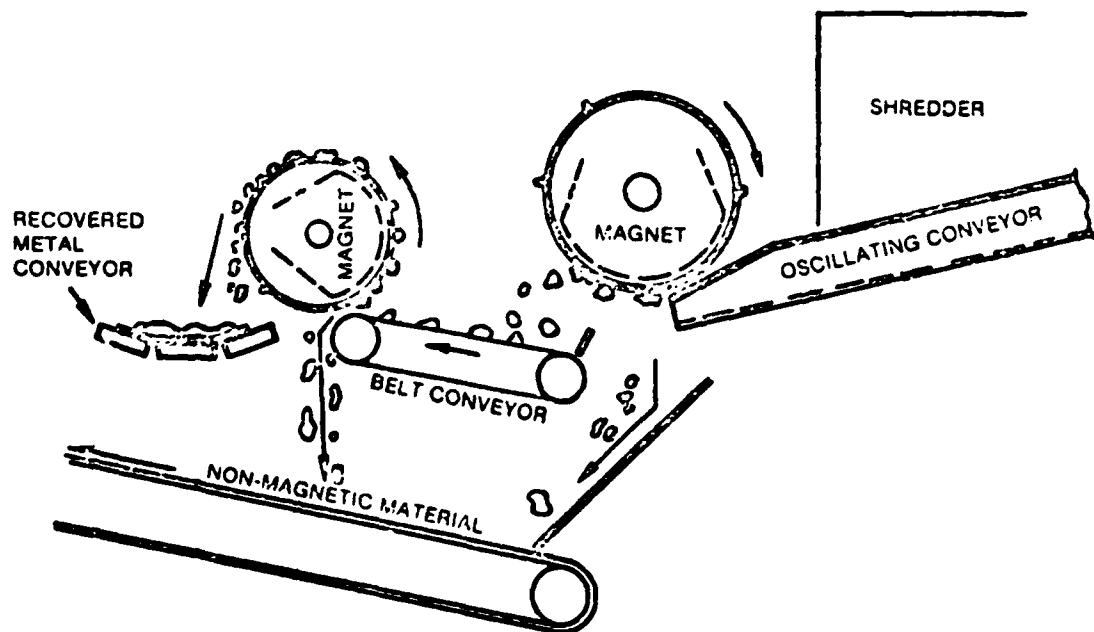

Figure A-5. Dual Drum Magnetic Separator⁸.

In a typical multistage separator (figure A-3), the pickup magnet attracts the ferrous metal; the transfer magnet then conveys the attracted metals around a curve, thereby agitating the flowstream. When the attracted metals arrive at the location where there is no magnetic attraction, the metals fall freely as does the nonmagnetic material trapped by the metal against the belt. At this point, the discharge magnet acts, and the ferrous metal is picked up to the belt and is discharged to another conveyor or a chute for collection in a storage container. To overcome excessive wear of the belt, a specially designed heavy-gauge stainless steel belt is generally used. In order to prevent wear of the drum, the drum shell of the drum magnet is generally constructed of abrasion-resistant manganese (nonmagnetic) steel. Other requirements for the drum magnetic separator are as follows⁹:

- Wiper-angle elements should be fitted over the outer surface of the drum so that the pickup metals are not bunched in a single area of the shell.
- Drum and flanges should be made from heavy ribbed castings or weldments.
- Shaft and thrust bearings should have provisions for lubrication from outside the drum.
- The magnetic element must be uniform in intensity across the drum face with its maximum strength at the pickup or feed area.
- Only the drum shell should rotate. The magnetic element is stationary and is anchored to the nonrotating shaft by heavy hanger plates.

Magnetic drum separators have been installed having diameters from 3 to 8 feet with a face width of up to 8 feet. The New Orleans Recovery-1 facility installed Stearns Magnetics Company's drum magnetic separators. An electrotype LD Model 104 LT (42-inch diameter by 54 inches long) is used for trommelled MSW; a 48-inch diameter by 72-inch long unit of the same model is used for shredded MSW. The trommeled MSW unit is designed for 25 TPH and the shredded MSW unit is designed for 37.5 TPH capacities⁹.

A magnetic separator unit requires little operator attention other than routine preventive maintenance. A recovery efficiency of 90% is not uncommon for magnetic separators. Manufacturers claim that the multiple drum installation and multipole belt magnet could achieve similar performance, but the initial capital cost of the drum magnetic separator installation may be 50% more than the belt separator. However, in the long run, based on operational use, belt separators may cost more to operate than drum separators⁹.

The primary concern of any magnetic separation system operation is the removal of organic contamination from the magnetic metal produced, particularly if the feed stock to the magnetic separator comes directly from the shredder operation¹⁰. During the shredding operation, the crushed magnetic metals may hold organic elements, such as paper, textile, plastics, etc, so that when the magnet picks up the metal, the organics are carried with the metal.

Previous experience has shown that air knifing (blowing air perpendicular to the flow stream of metals) can reduce the organic material contamination. When the organic material content of the ferrous metal exceeds 3-1/2% by weight, the market value of scrap iron decreases considerably.

Potential suppliers of the magnetic separators are:

- Dings Company, 4740 Electric Avenue, Milwaukee, WI 53246.
- Eriez Magnetics, Asbury Road at Airport, Erie, PA 16514.
- Stearns Magnetics, Inc., 6001 South General Avenue, Cudahy, WI 53110.
- Indiana General, 407 Elm St., Valparaiso, IN 46383.

A.2.4 Air Classifier

In solid waste resource recovery operations, air classification is used to separate the organic material (the "light fraction") from the heavier inorganic material (the "heavy fraction").

Types of air classifiers which are currently being used in solid waste processing facilities are⁵:

- Zig-Zag (Americology; Occidental)
- Horizontal (U.S. Bureau of Mines; Boeing Co.)
- Vertical (Allis-Chalmers; Radar; Triple/S)
- Impulse (William Patent Crusher)
- Drum (Raytheon)

A list of air classifier installations in refuse processing facilities is shown in table A-2. The above types of air classifiers are illustrated in figures A-6 through A-11.

Table A-2. List of Types of Air Classifier Installations⁵.

| Location | Type | Manufacturer | Application | Unit Size (TPH) |
|----------------------|----------------------------|-----------------------|-------------------|-----------------|
| St. Louis, MO | Vertical | Radar | RDF Production | 45 |
| Milwaukee, WI | Zig-Zag | Americology | RDF & Materials | 30 |
| Chicago, IL | Vibroeutriator | Triple/S | RDF | 80 |
| Houston, TX | Drum | Raytheon | Testing | 50 |
| San Diego, CA | Zig-Zag | Occidental | RDF | 25 |
| Washington, DC | Zig-Zag | NCRR | Testing | 25 |
| New Orleans, LA | Zig-Zag and Vibroeutriator | Triple/S & MAC Equip | Material Recovery | 30 |
| Ames, IA | Vertical | Radar | RDF | 45 |
| Appleton, WI | Vertical-Vortex | Allis-Chalmers | Testing | 5 |
| Baltimore County, MD | Vertical | Jacksonville Blowpipe | Testing | 60 |
| Seattle, WA | Horizontal | Boeing Co. | Testing | 1000 |

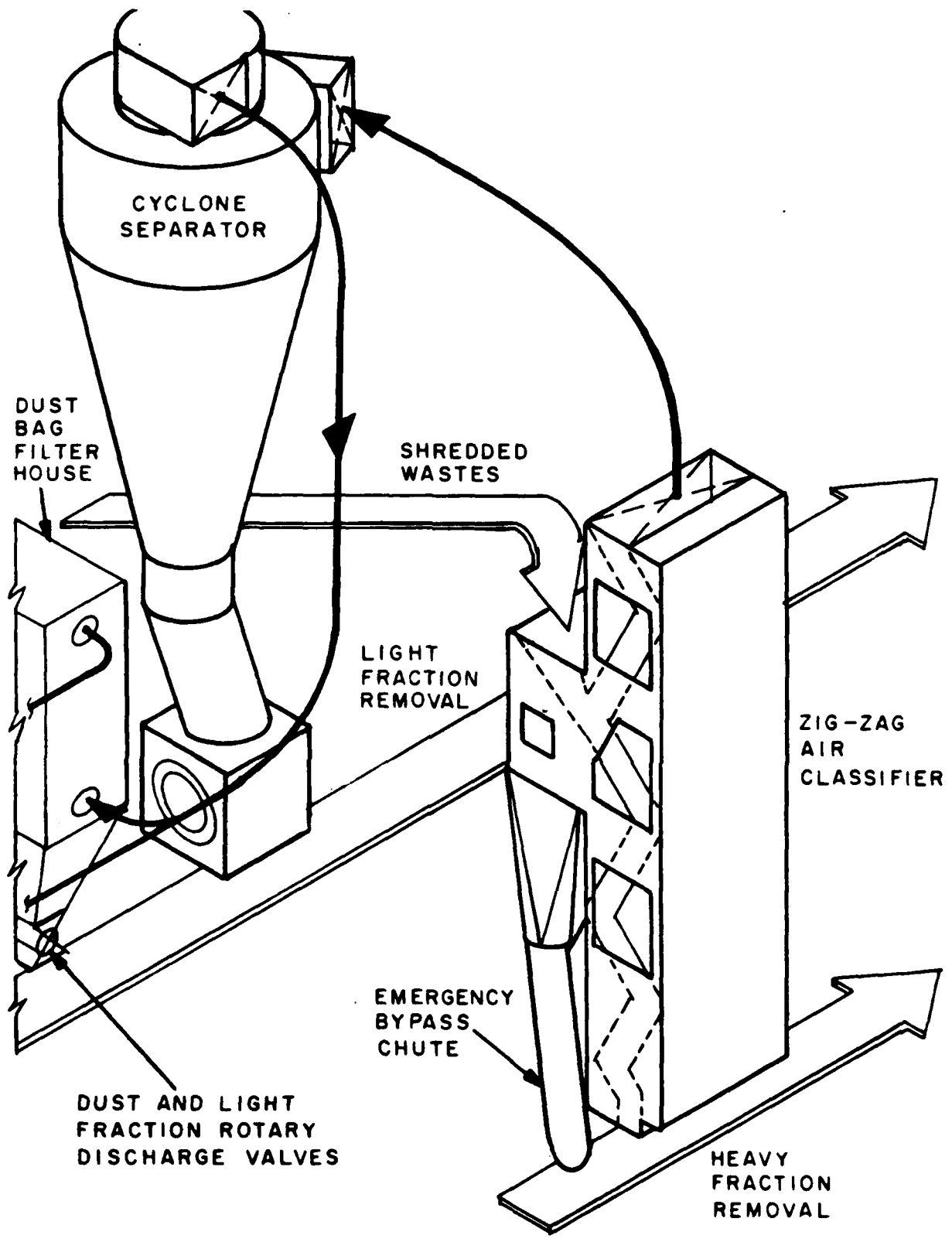

Figure A-6. Zig-Zag Air Classifier⁵
 (Americology Div.; American Can Co.)

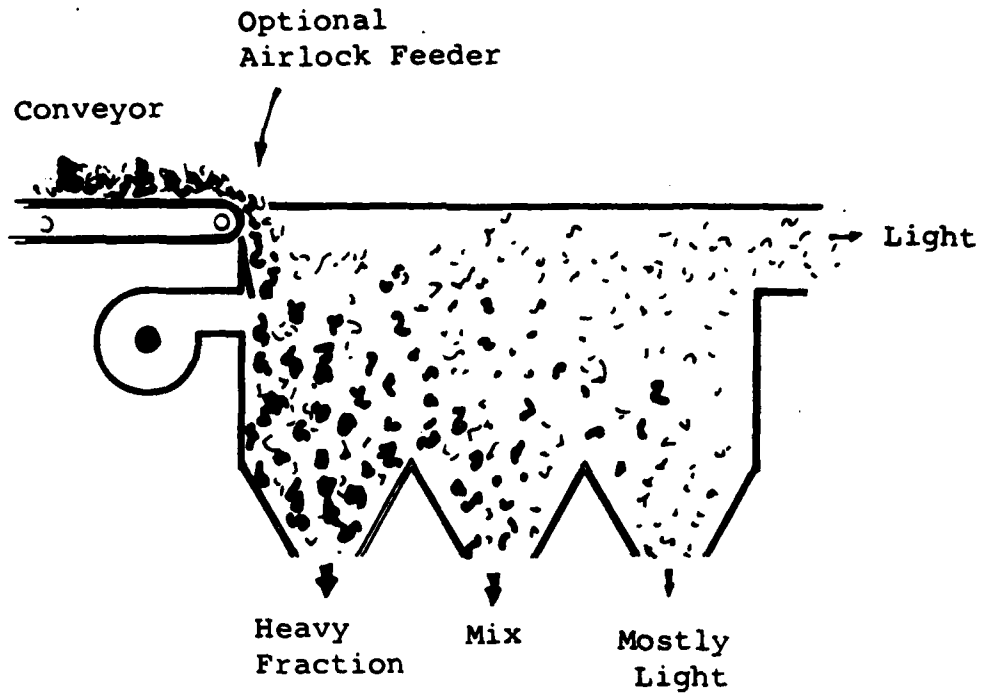

Figure A-7. Horizontal Air Classifier⁵
(U.S. Bureau of Mines).

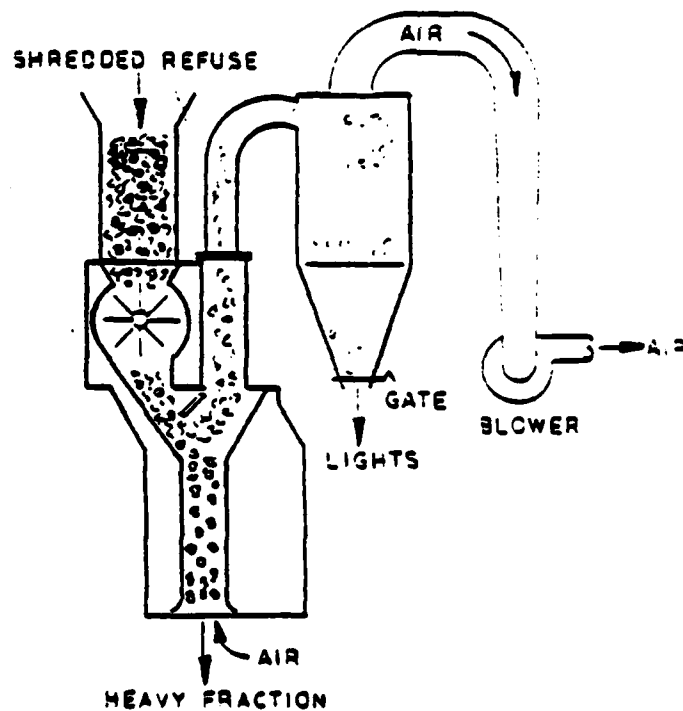

Figure A-8. Vertical Air Classifier⁵ (Allis Chalmers).

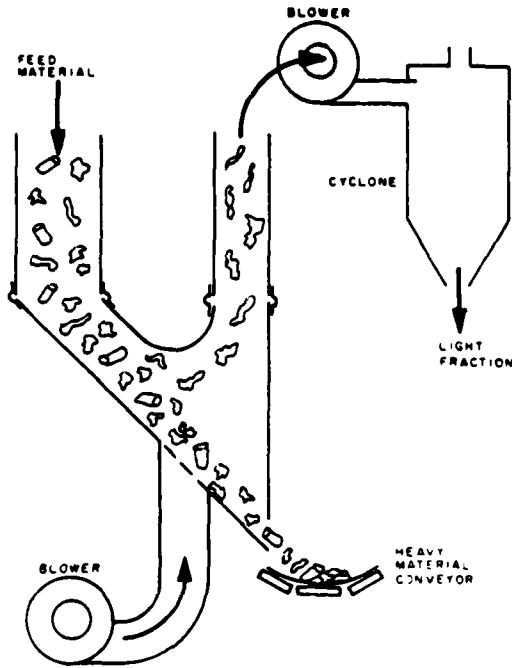

Figure A-9. Vertical Air Classifier (Triple/S)⁵.

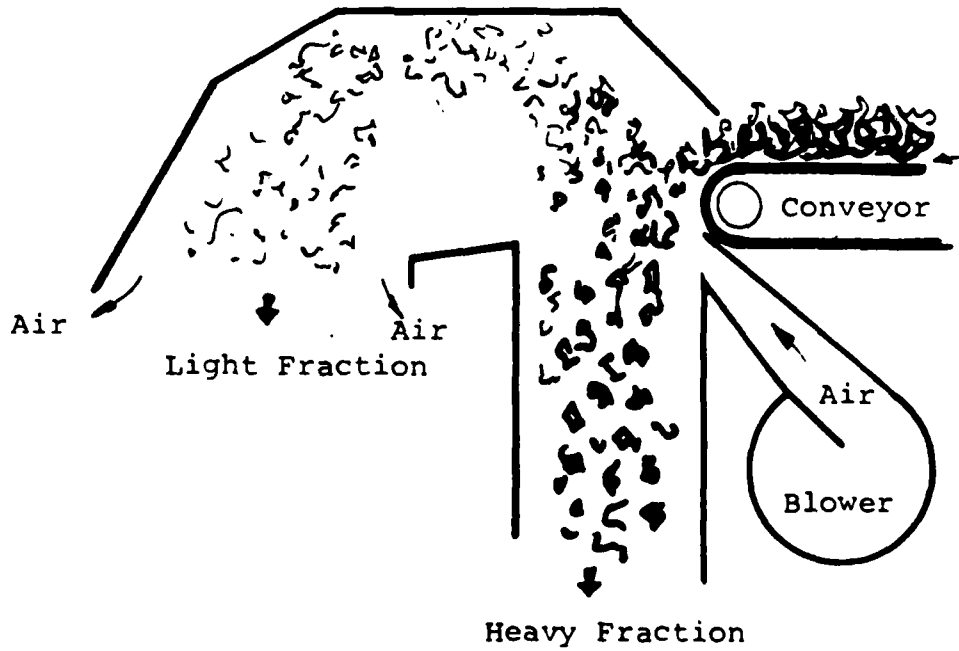

Figure A-10. Impulse Air Classifier⁵
(Williams Patent Crusher & Pulverizer Co.).

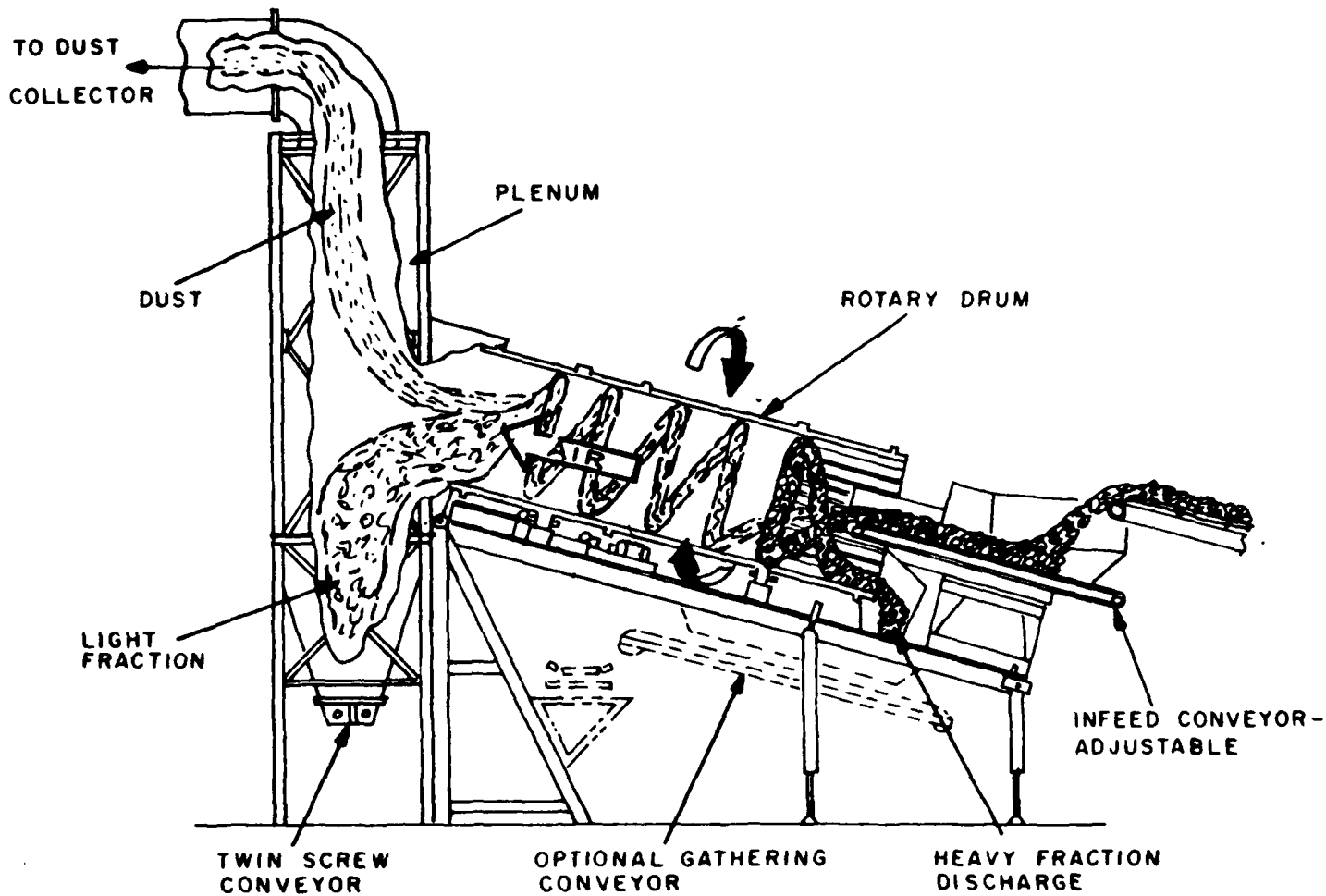

Figure A-11. Rotary Drum Air Classifier⁵ (Raytheon).

The air classifier feed may come from trommel underflow, shredder output, or shredder followed by magnetic separator output. In the New Orleans Recovery-1 facility, one Triple/S Dynamics unit with capacity of 30 TPH is used to process the trommel underflow.

An air classifier system consists of the following:

- A feeder: This can be a simple chute, but in most installations a device which can meter the flow of feed to the air classifier is used. In Occidental's San Diego project, a Doffing Roll bin (figure A-12) is used to feed the shredded MSW to the air classifier. A complete feed system may include belt conveyors, surge hoppers with drag chain conveyors, and rotary air-lock feeders.
- An air classifier unit.
- A blower: A motor-driven centrifugal fan which provides the primary air flow to the air classifier unit.
- A cyclone for initial separation of light fraction organics from blower air.
- An airlock feeder for removing the de-entrained material from the cyclone and to prevent air from migrating into or out of cyclone. This is required if the cyclone is under negative pressure.
- An air pollution control device for cleaning the cyclone exhaust before discharging into the atmosphere.

Factors that must be considered in the selection of an air-classifier system include:

- Characteristics of feed; i.e., particle size, gradation, shape, moisture content, tendency to agglomerate, and fiber content.
- Material specification for the light fraction element.
- Method of feeding.
- Design characteristics of the unit including solid-to-air ratio (lb of solid/lb of air), fluidizing velocities (ft/min), unit capacity (lb/hr), total airflow (ft³/min), and air pressure drop (inches of water).
- Operational features including energy requirements, routine and specialized maintenance requirements, simplicity of operation, reliability, noise, and environmental emissions.
- Site considerations including available space, height, and access.

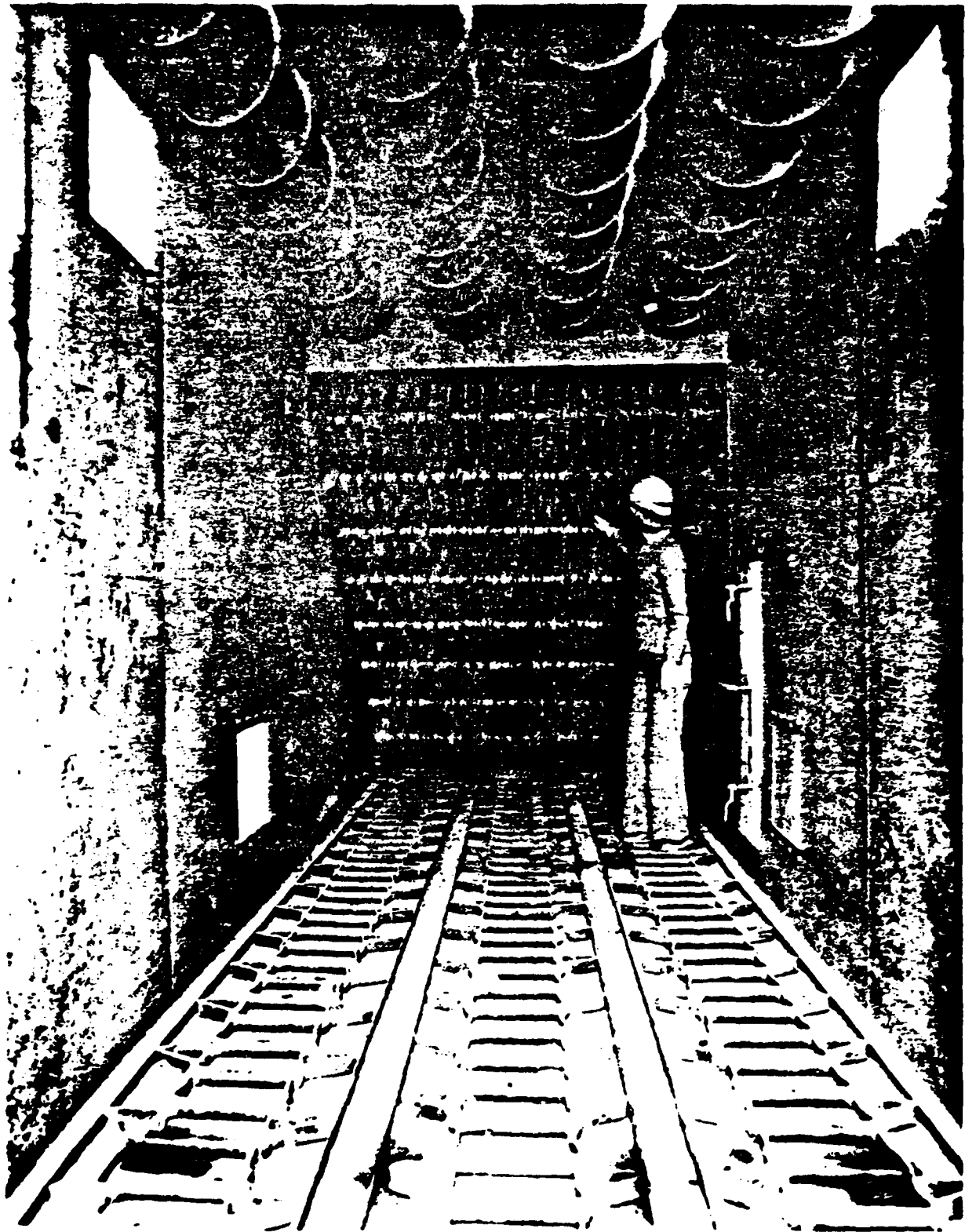

Figure A-12. Inside View of Doffing Roll Bin¹⁰.

The separating efficiencies achieved in the operation of the air classifier at the New Orleans Recovery-1 facility are:

- 70% or more of the feed stock is separated as the light fraction.
- 90% of the metal contents of the feed shall drop with the air classified underflow (heavy fraction).

In Occidental's Zig-Zag air classifier, with the feed of a shredded MSW, an 80 to 20% split between the light and heavy fractions is achieved. The design of the Zig-Zag air classifier is very complex and the reliability of operation is not high. Such an air classifier will require a controlled metered flow rate of feed, otherwise choking will occur. For trommel underflow type of feed, the Triple/S Dynamic's type of air classifier (figure A-9) is quite adequate.

A.2.5 Shredder.

Size reduction is often the first step in processing the municipal solid waste stream. Consequently, the unit process of size reduction affects all subsequent resource recovery and processed refuse handling equipment operations. Because of varying particle size, moisture content, chemical composition, and physical characteristics, MSW is not an ideal fuel. However, by shredding this as-discarded heterogeneous MSW, followed by separation of inorganics and inerts, by magnetic separation, air classification, and trommeling, the organic materials in raw MSW can be transformed into a relatively homogeneous fuel mixture with uniform size, heating value, and moisture content. Shredding of MSW also makes the recovery of metals and glass easier. The physical characteristics of MSW are changed after it undergoes a shredding process. For example, the basic objectionable odor of the as-discarded MSW is normally replaced by a more acceptable smell after shredding; whereas, the as-discarded MSW attracts rodents, flies, seagulls, etc., the shredded RDF is not attractive to such pests and scavengers. By shredding, the characteristic particle size

of refuse is reduced by at least one order of magnitude from that of raw refuse but the size distributions of shredded refuse typically span three to four orders of magnitudes¹¹.

It is important to understand that size reduction does not necessarily mean volume reduction. In some cases, the overall total volume of size-reduced material may be larger than that of the original volume. In designing an MSW processing train, various tradeoffs between coarse and fluff RDF products must be evaluated in terms of the fuel value, combustor design, conversion efficiency, and process economics.

MSW is a difficult material to shred. As the present size reduction technology still operates under the premise of brute force predominantly, the comminution of the heterogeneous refuse constituents causes severe wear and strain on the shredder mechanisms. It should be understood that the type of equipment to be used for reducing the size of and homogenizing MSW must be matched to the downstream process and the product specification. The Waste Management Equipment Manufacturing Institute has designated the following types of machines for refuse size reduction: crushers, cage disintegrators, shears, shredders, cutters, clippers, rasp mills, drum pulverizers, disk mills, hammermills, and grinders.

Hammermills are the most commonly used type of equipment in solid waste processing. This stems from the fact that solid wastes contain a high percentage of nonbrittle fibrous materials and the manner in which hammermill executes the size reduction process. Fundamentally, a hammermill is an impact machine in which the load (a combination of tensile, compressive, or shear forces) strikes the refuse components in suspension or hurls them at high speed against the breaker plates or cutting bars that are fixed around the periphery of the

shredder chamber. This striking action is continued until the feed material has been reduced to the desired size and is able to fall out of the gratings of the mill¹¹.

Hammermill machines have been designed with horizontal and vertical rotors. The horizontal unit, containing principally the rotor, hammers, grates, frame, and flywheel, is the type most frequently used. The construction of this type of hammermill is very simple. The rotor and the flywheel are mounted to the machine and gratings are located at the base of the unit. The hammers have been designed with various configurations, from simple rectangular shape (12 inches x 4 inches x 1 inch) to the more sophisticated shape of a chopper with a protruding wearing surface with sharpened edges. The hammers are flexibly attached to the rotor by hammer pins. The rotational centrifugal force causes the hammers to extend radially from the rotor, and, as the solid waste enters the chamber, it is hit with impact force to crush or tear it.

In a vertical machine, the rotor shaft is mounted vertically; the refuse moves parallel to the rotor axis, assisted by gravity. A variation of vertical hammermill type machine is the Eidal shredder. In this machine, size reduction is accomplished by a set of gear-like teeth installed in a rotor that fits in a ribbed housing. Size reduction occurs as a result of the induced shear and mutual self-comminution interaction between various refuse components. Since the space between the rotor and the shredder housing is tapered, small objects falling downward eventually exit through a peripheral opening at the bottom of the unit. This is a slow-speed machine; and therefore, the size-reduced objects are not rejected in the same manner as the hammermill machines. The specific power requirement of the Eidal shredder is similar to the hammermill machine.

The hammermill machine has relatively high maintenance which is primarily associated with the wear of the hammer. As the hammers wear, the particle size of the processed solid waste increases. In that situation, either the hammer heads have to be retipped or new hammers have to be installed. These machines also have high specific energy consumption (kwh/ton) ratings.

Recently cutter-type size reduction machines have been introduced for solid waste processing. These are slow-speed machines with smaller specific energy requirements. The cutter assembly of a Saturn shredder is shown in figure A-13. The Saturn shredder is a two-shaft, hydraulically-driven rotary shear type shredder. The shredder cutters can be mounted in various configurations to fit the size requirements and throughput. Low speed, high torque radial piston hydraulic motors provide the correct torque for shredder operation. By means of a hydraulic drive design, the cutting speed and shaft torque are controlled, eliminating costly repairs from self-destruction type damage



Figure A-13. Cutter Assembly on a Saturn Shredder¹².

commonly associated with high speed shredders. Because of the hydraulic drive system, electric horsepower is minimized, thereby reducing total electrical consumption. High energy costs associated with direct electric drive is not a consideration with this type of unit. Being a slow-speed machine, the Saturn unit is said to have low noise, dust, and explosion problems. A Saturn mill was recently installed at the Hooker Chemical Company plant at Niagara Falls, NY. William Patent Crusher and Pulverizing Company's "RIPSHEAR" shredder is currently being used in Dade County solid waste project.

Factors that should be considered in the selection of size reduction equipment include:

- Physical characteristics of material to be shredded.
- Size requirement for the RDF.
- Method of feeding, required shredder hood capacity to prevent bridging of the feed, and the clearance requirements between feed and transfer conveyors and shredders.
- Operating schedule (continuous or batch).
- Operating characteristics including energy requirements, routine and specialized maintenance requirements, ease of operation, ease of maintenance, reliability, noise, explosion, and atmospheric pollution.
- Site requirements including space, height access, and noise and environmental regulations and constraints.
- Sequence of operations following shredding; i.e., storage requirement or shredder output goes to next processing equipment directly over conveyor system.
- Type of size reduction equipment design; i.e., hammermill (ring, vertical, horizontal), flail mill, crusher, etc.
- Consideration of capital cost versus operating cost.

The capability of a particular size reduction machine is judged by the following three quantities taken collectively:

- The specific energy consumption (kwh/ton).

- The product size distribution.
- The machine wear and maintenance work.

The parameters that affect the above three quantities are:

- The moisture content of the feed.
- The feed size distribution.
- The flow characteristics of the feed through the mill.
- The specific design of the size-reducing device (rpm, fpm, etc.).
- Grate spacing.

The total horsepower required for size reduction of MSW by hammermill type shredders, as a function of feedrate and designed product size, is shown in figure A-14. The total horsepower includes the free-wheeling power that the machine needs in idling condition to overcome the bearing friction, air resistance of the whirling hammers, and other associated losses. To estimate the grate spacing required to yield a design product size, figure A-15 can be used¹¹.

Potential suppliers of shredders are:

- Heil Co.
P.O. Box 8676
Chattanooga, TN 37411
- Williams Patent Crusher and Pulverizer Co.
2707 N. Broadway
St. Louis, MO 63102
- Gruendler Crusher and Pulverizer Co.
- Pennsylvania Crusher Corp.
- Jeffrey Mfg. Division (Dresser Industries).
- Hammermills Inc.
800 First Ave., N.W.
Cedar Rapids, IA 52405
- Tractor - Marksman Inc.
- MAC Corporation/Saturn Shredders
201 E. Shady Grove Road
Grand Prairie, TX 75050

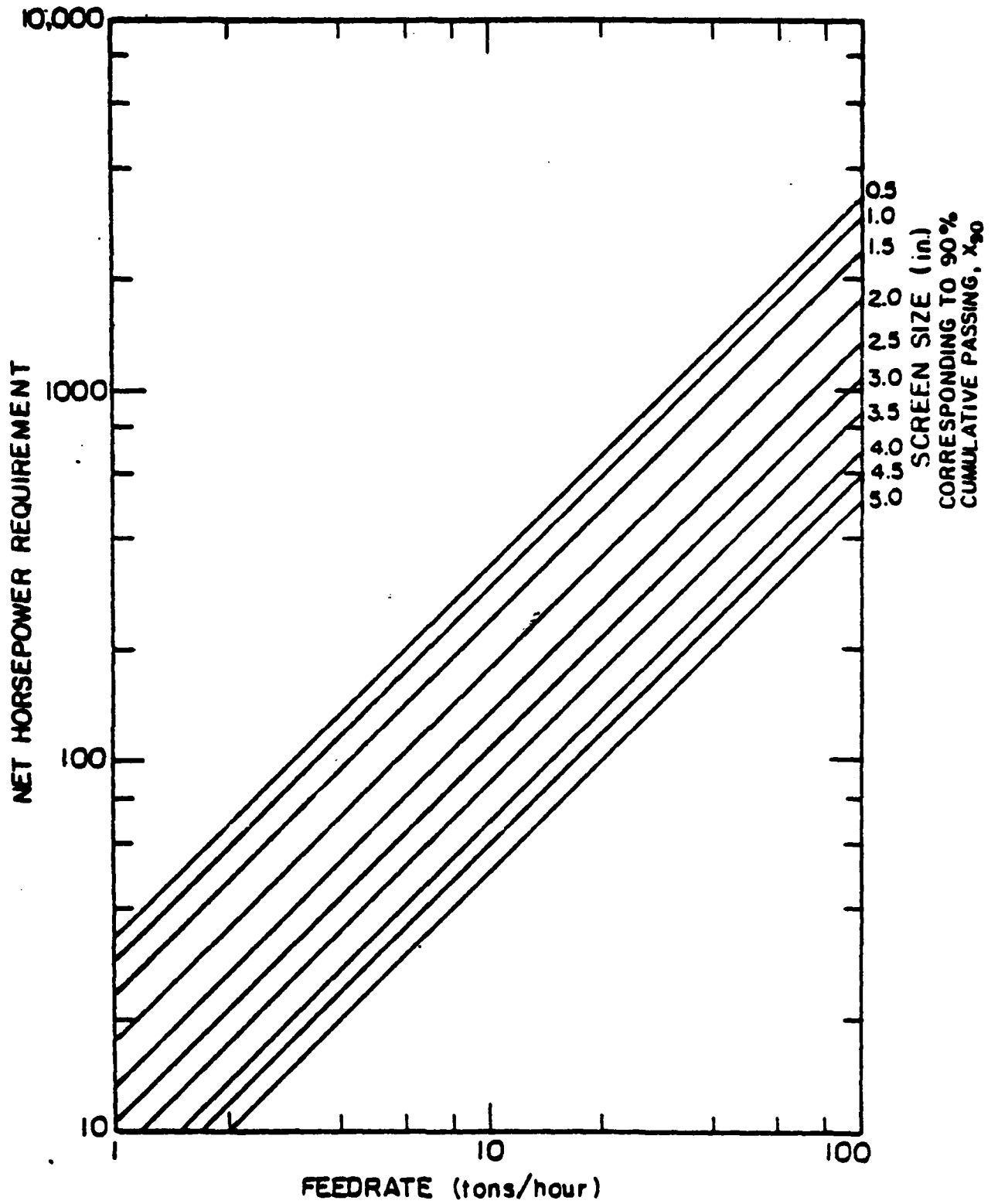
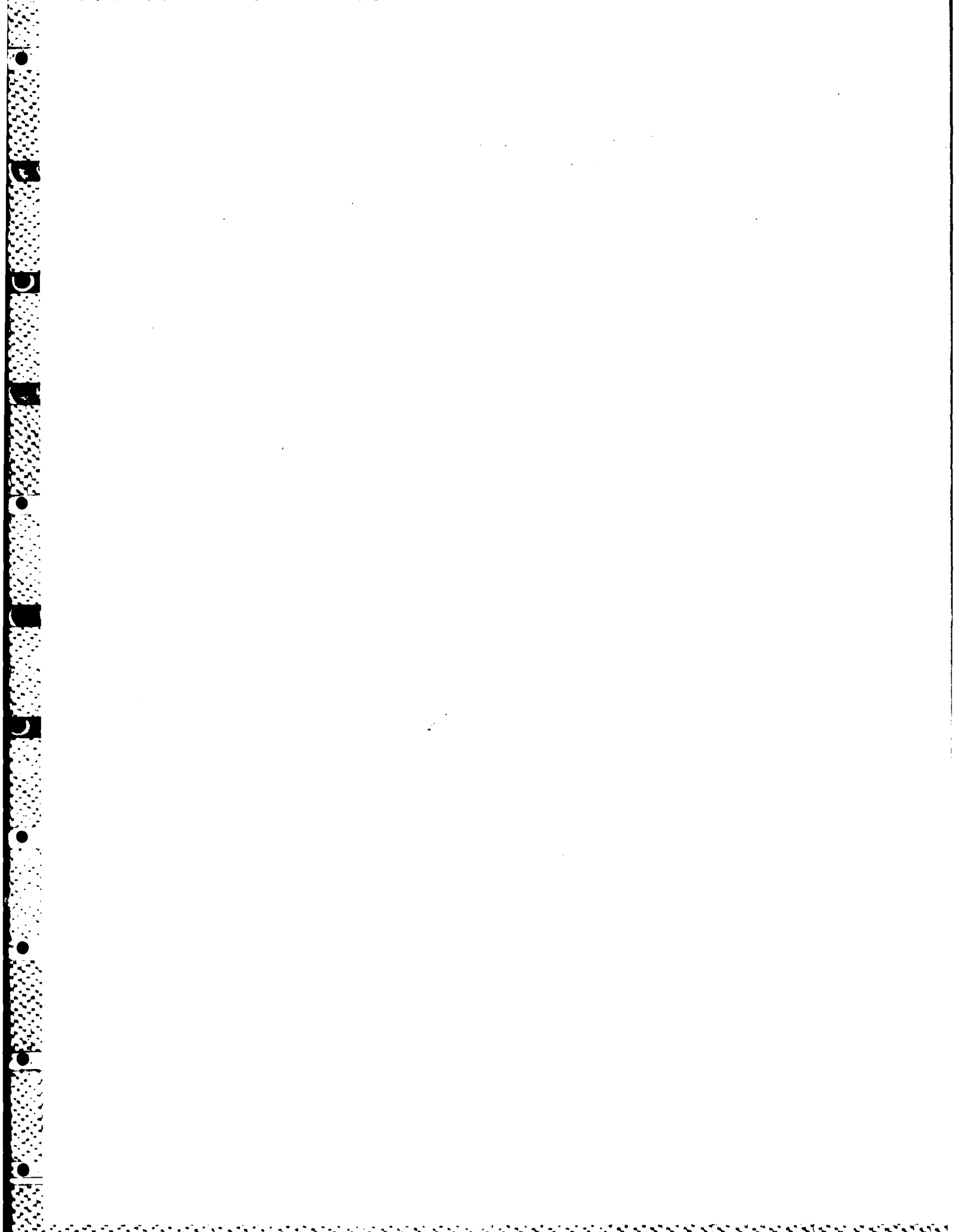

Figure A-14. Horsepower Required for Size Reduction of MSW as a Function of Feedrate and Desired Product Size¹¹.



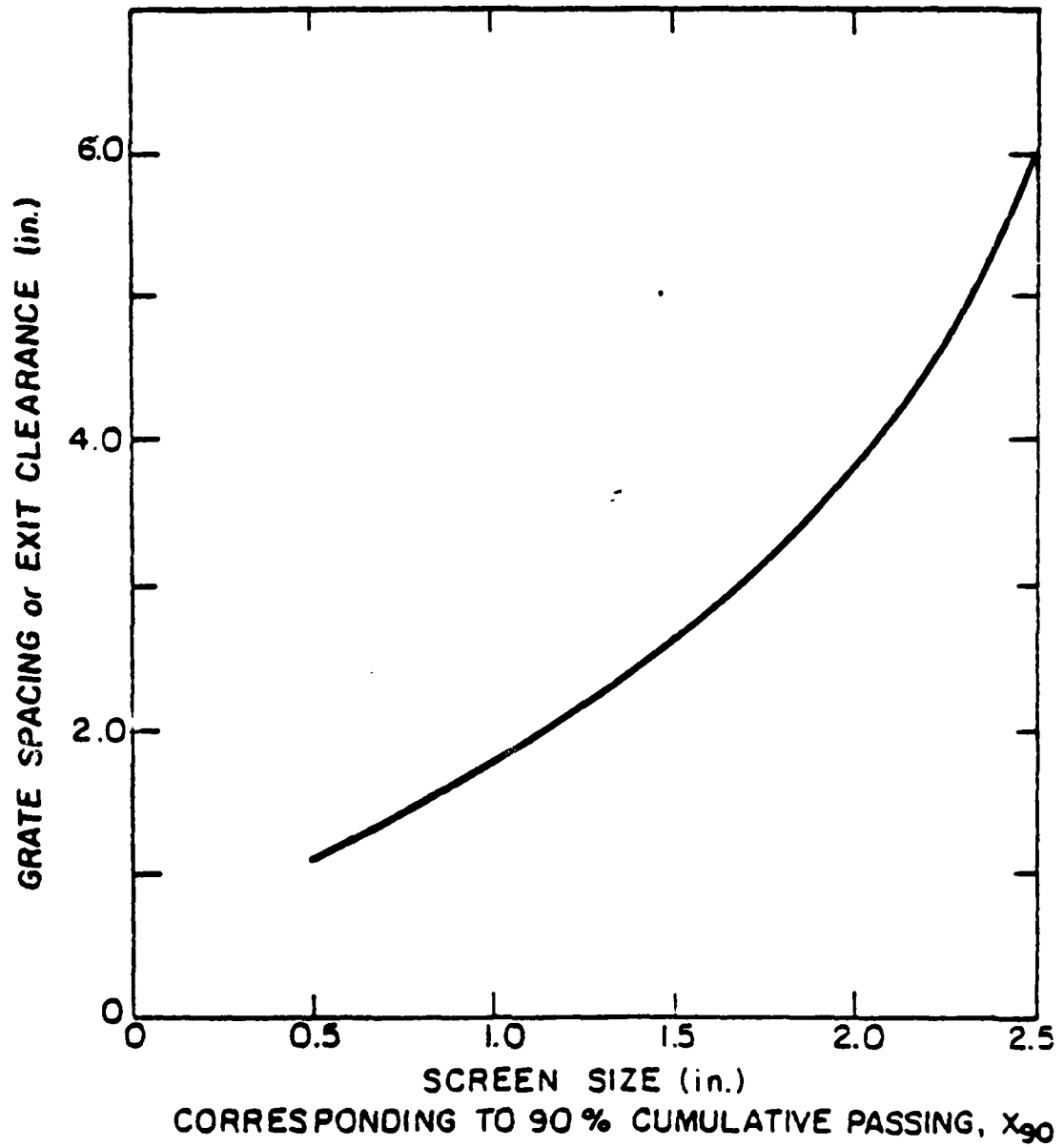

Figure A-15. Grate Spacing Required to Produce a Desired Product Size¹¹.

A.3 TRANSPORT AND DELIVERY SUBSYSTEMS

For a successful solid waste processing facility design, a systematic engineering approach for planning a solid waste material handling system is needed. In designing a solid waste handling and conveying system, the first step is to study the requirements for material handling including:

- Collecting data on the characteristics of the solid waste to be handled, such as maximum size, specific weight (lb/ft^3), flowability, dust, etc.
- Establishing requirements for the transport system in terms of volume to be handled and the distance to be transported.
- Studying the plant arrangement, size, and the final point of disposal, as well as the method by which the solid waste is to be transferred or loaded onto the conveyor.
- Establishing the profile of the travel path in terms of deviations from the horizontal travel, angle of inclination, vertical lift, horizontal carry length, and complexity of handling (interconnecting flow path).
- Collecting data on physical and chemical properties of materials to be transported including temperature, corrosiveness, and abrasiveness.

Processed and unprocessed solid wastes are conveyed by the following types of conveyors:

- Belt conveyor - preferably processed MSW.
- Pan (apron) conveyor - raw MSW.
- Drag chain conveyor - ash and residue.
- Screw conveyor - dry processed MSW (RDF).
- Vibrating conveyor - dry processed MSW (RDF).
- Pneumatic conveyor - dry fine processed MSW (RDF).

Discussion of these various types of conveyors is presented in the following paragraphs:

A.3.1 Belt Conveyor

A belt conveyor is an endless rubber or treated fabric belt. Four different basic designs of belt conveyors normally employed in solid waste industries are shown in figure A-16. Belt conveyors are available in a variety of cross sections and can be modified to suit individual applications. The belt conveyor type shown in figure A-16C has been widely used in handling of processed solid waste. It is economical to run, the skirtboard rubber seals need not be adjusted, and very little spillage occurs in such handling. The design of the belt drive is such that very little processed solid waste will work under the belt. The open spaces between the rollers causes a downward pressure; thus, the slider plate of the unit is sealed and very little material will get under the belt.

Belt conveyors use adjustable terminal pulleys to set the belt tensions and also to change direction. Rollers, idlers, and proper structural support and beds are required for efficient operation of solid waste belt conveyors.

Belt conveyors 12 to 48 inches wide have been used in solid waste processing facilities. Belt conveyors carrying processed solid wastes can be operated at inclines up to 25 degrees. When the belt inclination exceeds 25 degrees, special belts with cleats fastened to the carrying surface or belts with abrasive or grooved surfaces should be used. Such belt conveyors have been used up to an inclination of 60 degrees. In such steep incline installations, spillage generally occurs at the tail and discharge points of the unit, requiring daily cleanup of the spillage area. Special attention must be provided to insure that sufficient space is provided between equipment to prevent jamming or clogging with solid waste.

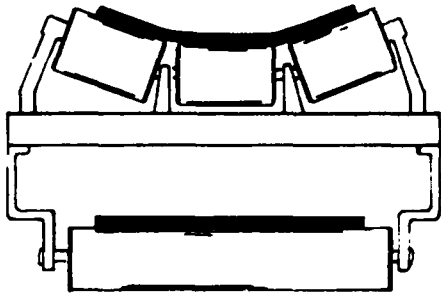

A. Conventional three-roll idlers are provided in widths from 18 through 72 in. They are commonly spaced at 4- to 5-ft intervals on channel or truss frames. These conveyor designs are normally used for high capacity installations. Continuous skirtboards can be provided to enable the conveyor to carry large pieces.

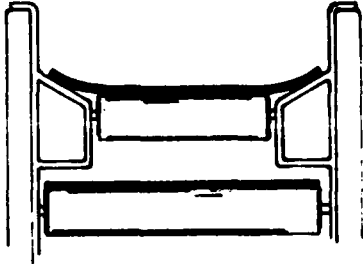

C. The combination trough slider and roller bed construction of this conveyor is ideally suited for handling waste material. Sideboards can be increased in height to handle large pieces.

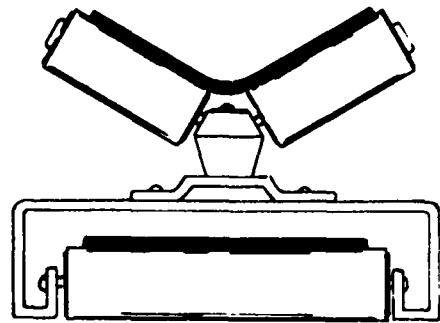

B. Two-roll carriers are generally spaced at 2½- to 5-ft intervals. Rolls are inclined at 35 deg, and can be supported on a formed bed to protect the return bed from spillage. Two-roll carriers provide medium duty service at moderate cost.

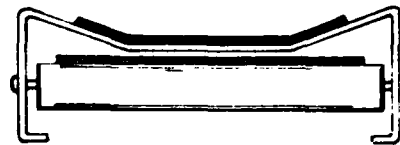

D. A one-piece formed, troughed slider bed is the lowest cost design of those shown. It is used for handling relatively light, non-abrasive waste materials.

Figure A-16. Typical Cross Sectional Designs of Belt Conveyors⁹.

A.3.2 Pan (Apron) Conveyor

A pan conveyor consists of a series of overlapping (interlocking) metal pans mounted on chains which operate on terminal sprockets. Sometimes the pans are provided with skirt plates or side wings to form a metal trough. Pan conveyors have been used having widths ranging from 18 to 72 inches. Units can be furnished with chains having a pitch of 2-1/2, 4, 6, 9, and 12 inches.

Unprocessed MSW can be carried by pan conveyors up to a 45-degree angle of inclination. Metal pan conveyors are designed for impact loading of as-discarded refuse. In many installations, the refuse is initially dumped on the tipping floor. After bulky items have been sorted, a front end loader generally pushes the rest of the refuse into the pit conveyor. The pan conveyor is used to feed either the trommel screen or the shredder.

Commonly, the pan conveyors are fitted with a leveling bar so that uniform loading of the conveyor and the shredder or trommel screen is maintained. In most installations, an automatic control device is used to ensure uniform feed rate to the machine.

The discharge end of the pan conveyor should be designed to avoid possible material carryback. Experience in pan conveyor operations has shown that fine materials such as wires or coat hangers can work their way into the unit's moving parts, causing wear and even conveyor stoppage. Sometimes a safety clutch device is incorporated in the unit to prevent possible damage to the unit. A typical pan conveyor installation carrying MSW to a shredder is shown in figure A-17.

A.3.3 Drag Chain Conveyor

This type of conveyor has an endless chain which drags the transport materials in a trough, ditch, or pan. Generally most of the ash and residue



Figure A-17. MSW Enters Pan Conveyor System⁵.

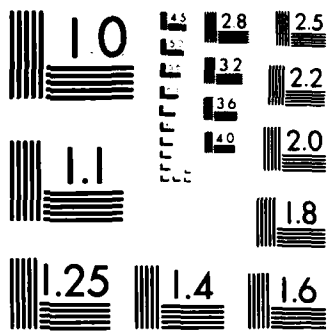

MICROCOPY RESOLUTION TEST CHART
NATIONAL BUREAU OF STANDARDS 1963-A

handling is done by a drag chain conveyor. Drag chain conveyors fall into two general design categories⁹:

- Double chain over and under
- Single chain side pull

When the transport flow path is in a straight line, with or without an elevation at the discharge end, an "over and under" type drag chain design is preferred. For more than one pickup and loop path, a side pull drag conveyor is desired. Such units have been installed in a shallow trench, with access from removable floor plates. Drag chain conveyors have been built in widths from 12 inches to 6 feet. Drag conveyors are sometimes operated immersed in cooling water in a trough or trench and they show very little wear, even in such usage.

A.3.4 Screw Conveyor

A screw conveyor consists of a steel helix mounted on a shaft suspended in bearings usually in a U-trough. As the shaft rotates, the material is moved by the thrust of the lower part of the helix and is discharged through openings in the trough bottom or at the end. When a screw conveyor is operated in an inclined path, its transporting capacity decreases with the increase in inclination.

A screw conveyor is not widely used in the solid waste processing industry, although it is among the simplest and most versatile type of material handling equipment and also the cheapest. However, if the screw conveyor is not properly selected, it becomes a very unreliable piece of equipment for a solid waste facility. Screw conveyors have been used to feed RDF that has been shredded, magnetically separated, air classified, and screened to the boiler or pyrolyzer units. Some limited use of screw conveyors has been found in handling

clean ashes. Standard screw conveyors can be furnished in widths from 6 to 24 inches. For solid waste handling, sizes of 12 to 24 inches are recommended.

A.3.5 Vibrating Conveyor

A vibrating conveyor is a simple trough, flexibly supported and vibrated at relatively high frequency and small amplitude. This type of conveyor can be used to transport any material that is not lumpy or sticky. The shredder output is usually carried by vibrating conveyors. In many cases, the self-compressed coagulated fine RDF is carried by vibrating conveyors. Powdered glass, sand, and other inert materials have been transported by such conveyors. The vibrating conveyors have caused problems in some cases by stratifying the transport materials.

Vibrating conveyors are commonly used for horizontal runs, feeding into each other at any angle. As a practical matter, most such transport systems are kept under 80 feet in length. Because of low maintenance, these conveyors have often been installed in pits. A vibrating conveyor is an expensive type of mechanical handling equipment. Standard widths vary from 10 to 60 inches.

A.3.6 Pneumatic Conveyor

A pneumatic conveying system is a pressure type and includes positive pressure displacement blowers, silencers, rotary feed locks, and cyclone separators. Pneumatic conveying is widely used in solid waste facilities, primarily to transport RDF. A supplemental fuel receiving and firing scheme by pneumatic conveyor is shown in figure A-18.

A.3.7 Truck Transport

In figure A-18, a self-unloading transport truck has been proposed to pick up processed MSW (RDF) from the remote solid waste processing facility. The truck transport mode is proposed even if the facility is located a distance

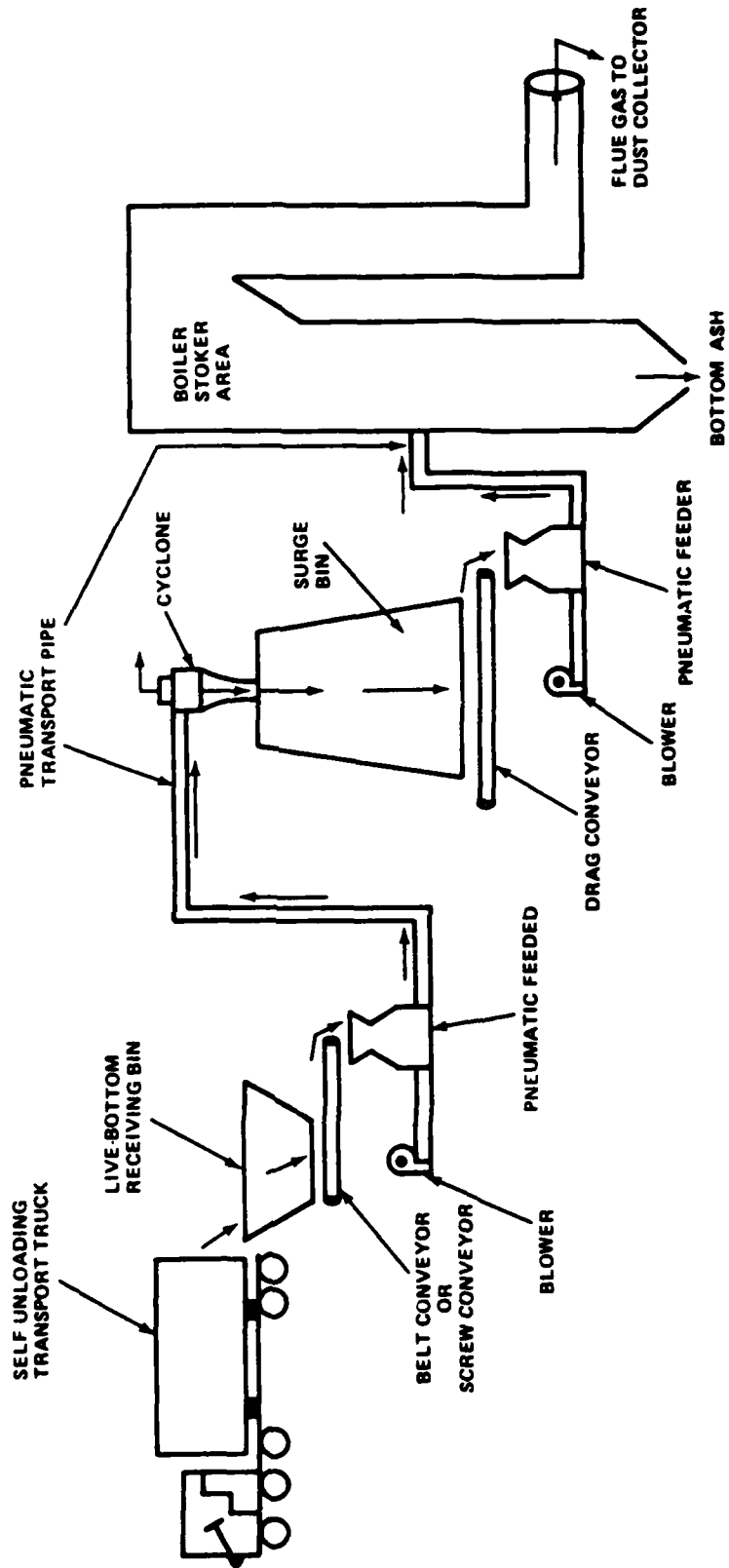

Figure A-18. Proposed Pneumatic Transport of RDF and Boiler Firing Scheme¹³.

of 1/4- to 1/2-mile from the steam plant. An alternate belt conveyor design concept will have the following disadvantages compared to truck transport:

- The belt conveyor system has to be totally enclosed to prevent dust emission.
- The belt conveyor system has to be totally enclosed to prevent effects of rain, snow, physical abuse, and even vandalism.
- Land encroachment, environmental, health, safety, and other regulatory permits will be required.
- With belt conveyor transport, the surge bin capacity has to be increased to bring the availability of RDF fuel for supplemental firing to the assurance level attained by truck transport.
- The capital and maintenance cost of a belt conveyor system 1/4- to 1/2-miles long will be equal to or greater than truck transport.

Compacted coarse RDF can be transported by short haul, self-unloading trucks to a fuel collection building; the truck can back into the building and dump the RDF to a live bottom collection box or a mechanical conveyor belt. The RDF can then be carried to the surge bin (Atlas, Miller-Hofft, etc.) either mechanically over belt conveyor or pneumatically. Similarly, firing to the stoker can be done either mechanically or pneumatically. In pneumatic feeding, the boiler furnace receives high excess air. Consequently by pneumatic conveying of RDF to boiler, the overall conversion efficiency of the boiler is reduced.

Pneumatic transport of RDF has been plagued with frequent plugging of the transport pipeline and excessive wear of the elbows and other pipe joints. RDF with high moisture content should not be transported by pneumatic pipeline. Similarly, RDF containing a high percentage of crushed glass will cause heavy wear to the pipeline system. For this reason, all pneumatic lines should be installed with replaceable wear back liners made of alloy steel (Astroloy or CR25 wear resistant metal alloys). Glass fiber-reinforced epoxy resin lined with aluminum ceramic or R35 abrasion resistant cast metal has been tried as

elbow wear plate. In some installations, the pneumatic conveying line to the storage bin or to the boiler is fitted with a pressure sensor adjacent to the blower. If the RDF in the line starts to clog, the pressure in the conveying line will increase. This increase in pressure can be detected by a sensor which activates a switch to stop all conveyor operations. This will prevent the rotary air lock from overfeeding RDF into the pneumatic line and thus causing a major plug.

The advantages and disadvantages of mechanical versus pneumatic conveyor systems for delivering RDF fuel (as supplemental fuel to coal) to a retrofitted stoker-fired boiler from a surge bin located in close proximity to the boiler are given in table A-3.

Table A-3. Advantages and Disadvantages of Mechanical and Pneumatic Conveyor Systems.

| <u>Mechanical Conveyor</u> | <u>Pneumatic Conveyor</u> |
|---|---|
| <u>Advantages</u> | <u>Advantages</u> |
| <ol style="list-style-type: none"> 1. Simplicity in operation and equipment 2. Low capital and maintenance costs 3. No noise problem 4. Easy to feed in a retrofitted boiler | <ol style="list-style-type: none"> 1. Contained flow of RDF 2. No dust problem 3. Easy to feed the boilers (tangential or stoker-fired) 4. Cheaper to transport from long distance storage 5. Ideal for transport of fines and fluff RDF |
| <u>Disadvantages</u> | <u>Disadvantages</u> |
| <ol style="list-style-type: none"> 1. Dust problem to surroundings 2. Fluff and fine shred RDF is difficult to transport 3. Spillage and associated incidents 4. Dust explosion, fire hazard, etc. exists 5. Costly retrofitting of fuel hopper, chute, etc. | <ol style="list-style-type: none"> 1. High noise level of blower 2. High capital and maintenance costs 3. Low operational reliability due to plugging and erosion of pipeline 4. Air lock (star valve) feeder valve operation problems |

A.4 Storage and Retrieval of RDF

Storage and retrieval of RDF have created problems in almost all processed-refuse burning facilities. Even after size reduction, RDF exhibits certain characteristics that create considerable difficulty in its controlled rate retrieval due to bridging, arching, ratholing, compaction, abrading, erratic retrieval rates, and even fire. The root of this problem lies in the difficulty of producing a uniform product of RDF within the acceptable limits of mechanical handling system design criteria^{14/15}. For example, a nominal 1-inch size RDF will contain refuse components with a maximum dimension in any direction of 4 to 6 inches. Further, a high percentage of stringy materials, such as soft plastic wrappings, cloth, wire, rope, hosiery, etc, are also present in this so-called homogenized RDF fuel. These elements of RDF are primarily responsible for almost all the failures of retrieval systems. These stringy materials paralyze storage and retrieval systems by their pronounced tendency to wrap around the rotating equipment and constant buildup on such equipment systems. The presence of long fibrous materials in the prepared RDF will have a similar effect as a reinforcing bar in concrete construction; these fibrous materials increase considerably the tensile strength of the RDF body, and a stored RDF mass behaves like a completely changed body (mass of material).

Another problem associated with the storage of RDF is the material compaction and mass density of the refuse pile. This problem is complicated by the fact that prepared refuse has very poor flowing characteristics; when such materials are compacted in a refuse pile of 70 feet height, for example, its mass density can increase from 2 lb/cu ft to 25 lb/cu ft. This is further complicated when the compressed refuse pile creates internal pressures in the

storage bin. With the increase in wall pressure, the combination of material compaction and frictional forces against the wall will be higher than the gravitational forces acting upon the RDF pile and arching or bridging will occur. Such a bridging situation can also create a structural problem for the storage bin.

The bulk density of the stored RDF will also affect the torque requirement of the driving mechanism of the retrieval system. As the stored material is retrieved, its compressed bulk density will decrease, and a constant mass feed rate will be difficult to maintain.

Several steps have been suggested by the bin manufacturers to reduce the wall effect bridging problem. One is to choose the structural wall material that offers least frictional resistance. Sloping of the bin walls outwardly at the base and providing vertical screws have also been tried. Another approach is to change the geometric configuration of the bin; i.e., decreasing the height of pile in favor of increasing the width and length of the bin to achieve the same capacity. However, none of the above methods have completely solved the problem of bridging. This problem is further complicated by the wide range of normal angle of repose, from 45 to 70 degrees, and this variation will depend upon such factors as fiber size, moisture content, etc.

Storage of RDF on an open concrete floor, rather than within a confining structure, has also been tried. A stacking conveyor device has been used to distribute the prepared refuse over the storage floor, and a front-end loader used to transfer the refuse to the pneumatic or mechanical conveyor bins. Occidental Corporation's El Cajon facility used this concept with considerable success. If the processed RDF material can be stirred or aerated and not left to stand in a static state for a considerable period of time, the problems

associated with breakaway shear force of the material and the frictional forces of the material on the bin walls will not occur.

From the above discussion, it is evident that two factors, reduced pile height and continuous or frequent movement of the material, are solutions for the RDF storage and retrieval problem. The live bottom bin retrieval approach involving an open bin equipped with apron conveyors has been proposed by Rexnord, Inc. Two major storage and retrieval systems that are presently used in RDF storage and retrieval facilities are Atlas System and Miller-Hofft System. The Doffing roll bin device as shown in figure A-12 has worked well in the San Diego project. In such a bin, the prepared refuse enters into the bin from the top. The drag chain located on the floor pulls the refuse mass to the feeder. The rooftop screws keep the storage mass stirred and also aids the drop chain in pushing the RDF to the feeder. The bristled rollers are used to spin the RDF to fluff condition. Doffing roll bins are used as an interstage storage bin.

The Atlas equipment system manufacturer claims the following merits for their equipment¹⁶:

- The retrieval system constantly works on the outer perimeter of the stored material. This feature provides several advantages:
 - The retrieval system can be examined at any time to determine the extent of wear and any potential mechanical problems.
 - Preventive maintenance and major repair work can be achieved without discharging the stored material.
 - The retrieval system is not subjected to forces exerted by the total head of the stored material. This feature contributes to the reduced energy consumption for the retrieval equipment.
- The system can be easily adapted for multiple boiler feeding without requiring any exterior flow dividers. The system concept is applicable in an almost infinite combination of sizes, feed rates, and configurations.

- The systems are available from 15 feet to 125 feet in diameter and there are virtually no limitations of the size for a particular design.
- By using the Mark 320 series control system, the fuel discharge rate can be controlled within $\pm 5\%$. This allows the Atlas system to operate as the prime metering control device. The Mark 320 control module provides manual or automatic volume control through a variable speed sweep system and one or more variable speed discharge conveyors. The basic control system is composed of three elements: the control enclosure, the basic operator panel, and the discharge stream height sensor.

A sketch of the Atlas storage and reclaim system is shown in figure A-19. It is seen from this figure that recovery of the material from storage is achieved by chains of sweep buckets. Depending upon the bin diameter and required volume rate, 3 to 6 sweep chains are used. Each sweep chain is fixed at one end to a powered rotating "pull ring" encircling the storage area; the other end is trailing. With the rotation of the pull ring around the periphery of the bin, the sweep chains automatically trail toward the center. The sweep buckets contact the stored material at the outside of the pile and as the pull ring continues to rotate, the buckets fill and the material is swept through the grate openings onto an outfeed conveyor recessed in the floor. The conveyor then delivers the recovered material at a uniform and controlled rate to the boiler. The unique design feature of the trailing chains provides continuous and automatic position adjustment so that the scrapers feed from the outside of the pile under all conditions, without being affected by the bridged compacted materials.

The manufacturer points out that the top surface of the foundation floor slab is subject to abrasive attack from the retrieved RDF and the sweep buckets sliding on the surface. Special design considerations are recommended in the design and construction of the topmost surface of the floor slab in those areas where wear will be experienced. The Atlas unloading system has an inherent

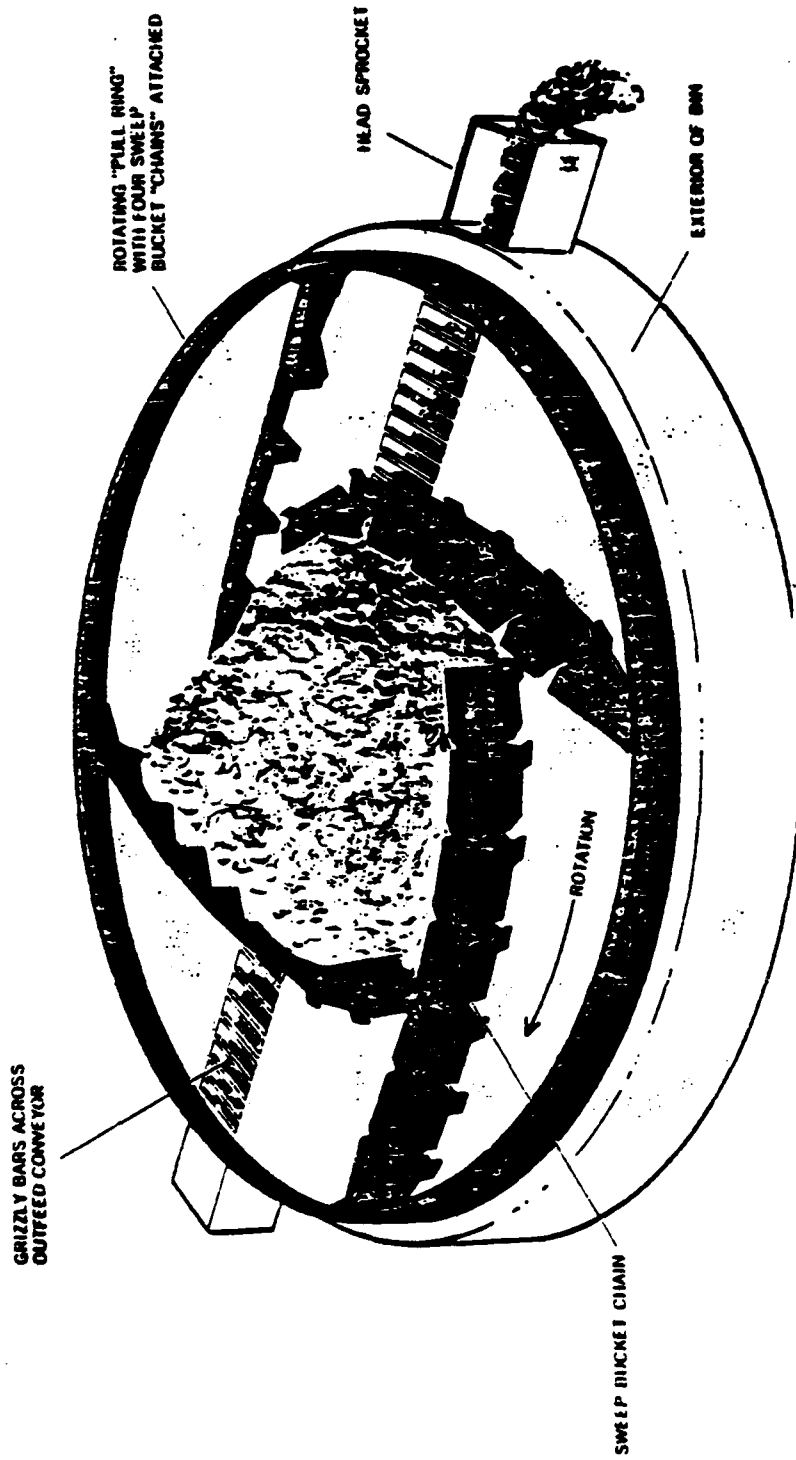

Figure A-19. Atlas Storage and Reclaim System¹⁶.

defect in that it leaves a large conical pile (see figure A-19) of dead material at the center. This accumulation of material can cause problems due to the decomposition of organic refuse. It is possible that dangerous concentrations of methane gas will be formed in this stationary pile. Incidents of fire in an Atlas bin is common. To avoid fire hazard, the stationary conical pile has to be manually removed at least every 2 weeks. Otherwise, the pile will form into an unbreakable cement-like structure. The Atlas system works on the principle of first-in, last-out.

The Miller-Hofft storage and retrieval system works on the principle of first-in, first-out. Akron, Hooker Chemical, Madison and St. Louis solid waste facilities use this type of storage and retrieval system. Such bin floors are covered with closely parallel feed screws which move the material horizontally across the bin floor to the discharge outlet. Material pickup through the screw length is assured with variable pitch screw flights with the greater pitch distance at the discharge end. The screws provide positive volumetric discharge, however, care should be taken to avoid excessive pile heights compacting the middle sections of the material.

A.5 COMBUSTION SUBSYSTEMS

A.5.1 Stoker Coal-Fired Boiler

Early in the history of steam boilers, mechanical stokers were developed as an improvement over hand firing. Almost any type of coal can be burned successfully on some design of spreader stoker. Spreader stokers can also accept many waste fuels having high moisture and high ash contents, such as bark, bagasse, wood wastes, coke breeze, and solid wastes, either as a base or as auxiliary fuel.

There are two main groups of stokers. The grouping is based, primarily, on the method of introducing fuel into the boiler furnace¹⁷:

- Overfeed stoker.
 - Spreader type.
 - Traveling grate.
 - Chain grate.
- Underfeed stoker.
 - Single retort.
 - Multiple retort.

In an overfeed stoker, the fuel is fed onto a traveling horizontal surface and air is fed upward through the grate to the fuel bed. In an underfeed stoker, the coal is fed below the point of air admission to agitate the fuel bed. The spreader variety of overfeed stoker is most widely used for coal-fired boilers in the capacity range of 75,000 to 400,000 lb/hr¹⁷.

Underfeed stokers are generally of two types: the horizontal-feed, side-ash-discharge type and the gravity-feed, rear-ash-discharge type. The single retort centerfeed horizontal-type stokers are generally limited to small heating plants with steam capacity of 25,000 to 30,000 lb/hr.

The multiple-retort underfeed stokers have almost been replaced by spreader stoker units. In general, underfeed stokers are able to burn caking coals. The range of agitation imparted to the fuel bed in various designs of underfeed stokers permits the use of coal with degrees of caking properties.

In the spreader stoker, as the name implies, fuel is projected into the furnace over the fire with a uniform spreading action, permitting suspension firing of the light fine particles of fuel and grate combustion of the heavier fuels. This type of firing is generally called "semisuspension" firing. In semisuspension firing, flyash and cinder carryover is high, causing high carbon loss. For this reason, most spreader stoker units are equipped with flyash

reinjection devices. In spreader stoker coal-firing, the secondary combustion air is admitted through a series of nozzles so located that the air stream and coal (fuel) spread out by the feeder are mixed upon firing. The primary combustion air is injected through the pinholes of the grate evenly over the grate's surface. A spreader stoker coal burning unit consists of:

- Fuel distribution units to distribute the fuel evenly over the entire grate.
- Specially designed air metering grate.
- Forced draft fan to supply both overfire and underfire air.
- Dust collection system (baghouse or ESP).
- Flyash reinjection system.
- Appropriate combustion control system to coordinate fuel and air supply with boiler steam demand.

Figure A-20 shows the modified traveling grate stoker coal-fired boiler. Overfire injection to a chain grate spreader stoker is shown in figures A-21 and A-22.

All spreader stokers, and in particular the traveling-grate spreader stoker type, have the extraordinary ability to burn fuel having a wide range of combustion characteristics, including fuel having high moisture and high ash content. For this reason, co-firing of RDF with coal is generally appropriate for this type of stoker unit. Fuel size segregation is a problem with any type of stoker. Size segregation, where fine and coarse fuel particles are not distributed evenly over the grate, produces a ragged fire, resulting in poor conversion efficiency. For this reason, homogenized RDF fuel is more appropriate for co-firing with coal. An ideal spreader stoker will have an evenly distributed fuel bed of 2 to 4 inches thick. Maximum design heat release rate of 450,000 to 750,000 Btu/ft²/hr is acceptable for such stoker units. Traveling

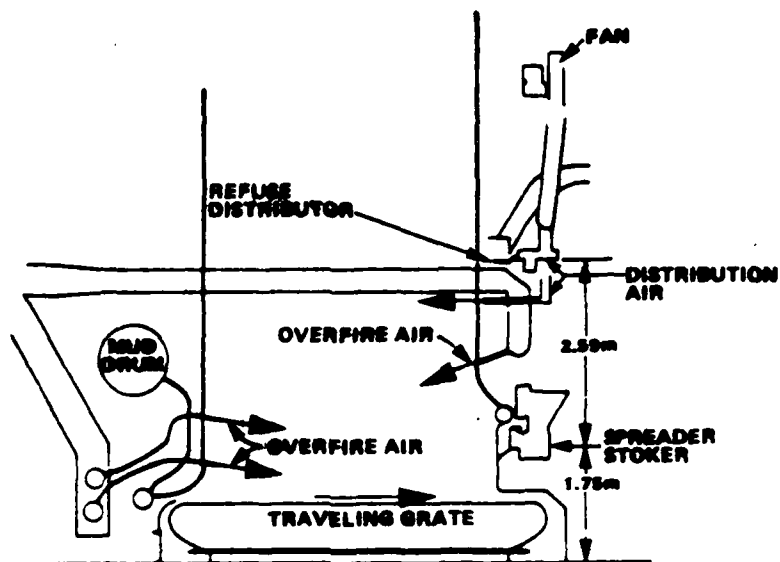

Figure A-20. Modified Traveling Grate Stoker Coal-Fired Boiler¹⁸.

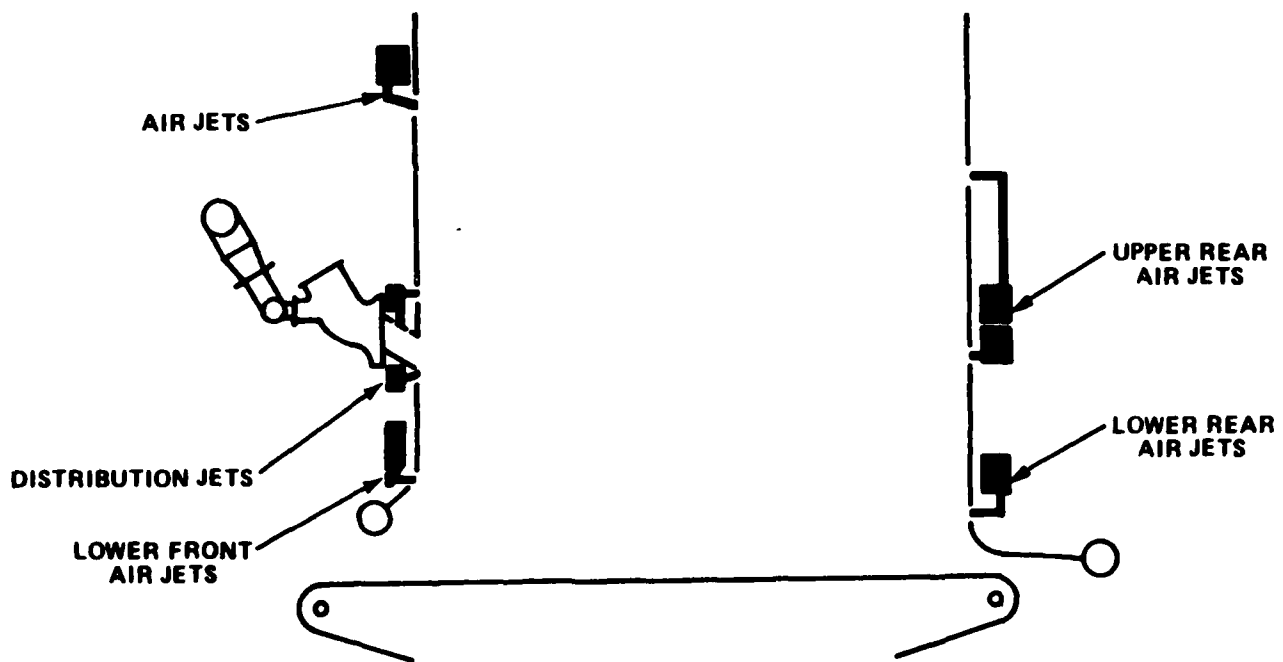

Figure A-21. Overfire Air Jets¹⁹.

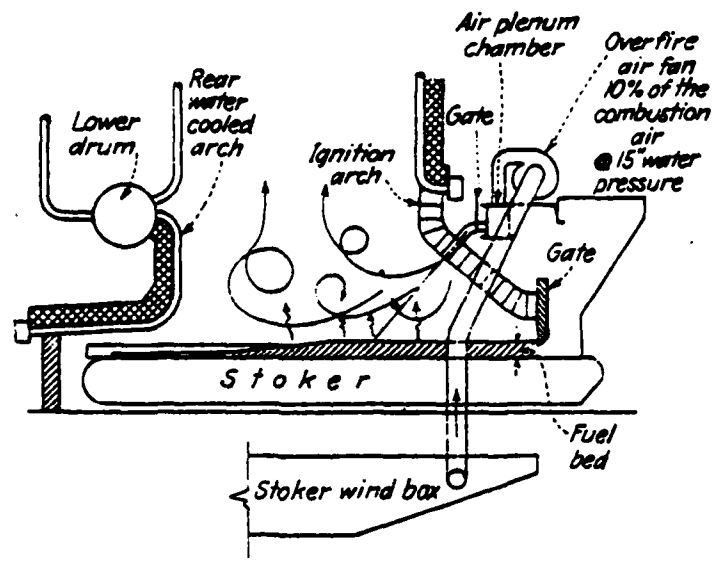

Figure A-22. Overfire Air Application to Chain-grate Stoker¹⁷.

grate stoker units have no limits on maximum ash content of fuel. Traveling grate continuous ash discharge stokers generally require either a basement ash pit or elevation of firing level to obtain the required ash storage space. The recommended maximum net length of traveling grate is 18 feet. Ashes are generally removed from ash pits for final disposal by means of the conventional ash-transport systems, such as pneumatic (vacuum) conveyors and hydraulic sluicing systems.

In a coal-burning, stoker fired boiler, ash handling is a major problem because:

- The ash is dusty, hence irritating and annoying to handle.
- It sometimes forms clinkers by fusing together in large lumps which must be broken before being given to any conveying equipment.
- The ash is abrasive and will wear all conveyor parts which it contacts.

Ash disposal system for coal-fired boilers are designed for intermittent or continuous operations. An ash disposal system consists of a means for removing

ash from the furnace and loading it onto a conveyor system to storage and a means of disposing of stored ash. A hopper to deliver the furnace bottom ash can be directly discharged to ash cars or trucks for disposal in local landfills. For large boiler plants, hydraulic sluicing is generally an option for ash handling. Pneumatic ash conveyors have been especially developed for handling of both abrasive and fine dusty ash, flyash, and soot; these conveyors are not particularly suited for furnace hopper bottom ashes.

Almost all coal-burning boiler plants require some kind of air pollution control equipment system. Air pollutants from a coal-burning boiler consists of particulates and gaseous emission, such as SO_x , NO_x , trace metals, etc.

The following are commonly used particulate removal equipment systems:

- Electronic precipitation (ESP).
- Fabric filter.
- Wet scrubber.
- Mechanical collectors (cyclones).

The collection efficiency of an ESP is related to the resistivity of the dust particle, the time of particle exposure to the electrostatic field, and the strength of the electrostatic field. A collection efficiency of 99% can be expected from an electrostatic precipitator. This equipment has a high capital cost and low maintenance cost, and many industrial/commercial boiler plants are now fitted with ESP units.

A fabric filter system has the highest collection efficiency. Its capital cost is lower than ESP but maintenance costs (for bag replacement) are higher. Its application to boiler plants is not competitive to ESP. The fabric filter system, commonly called baghouse, operates by trapping the dust particles by impingement on the fine filters comprising the fabrics. The baghouse obtains its maximum efficiency during the period of dust buildup.

Both ESP and baghouse are used to clean only the particulate matter from the gas, whereas wet scrubbers can be used to clean both particulate and gaseous pollutants. Collection efficiency, dust-particle size, and pressure drop are closely related in the operation of a wet scrubber. The operating pressure drop varies inversely as the dust particle size, for a given collection efficiency; or, for a given dust particle size, the collection efficiency increases as the pressure drop increases. The initial capital cost of a wet scrubber is lower than the baghouse, but its operating cost is higher because the scrubber system may need water pollution control equipment.

Mechanical collectors, sometimes called inertial separators, operate by exerting centrifugal force on the particles to be collected by introducing dust-laden gases tangentially into the cyclone. Mechanical collectors are good for large size particulates (10 microns) and are therefore sometimes used as first stage gas cleaning equipment, ahead of the baghouse or ESP. Mechanical collections of particulates alone can seldom meet any admissible air pollution codes.

Control of gaseous pollutants is more difficult than particulate matter. High sulfur coal burning will produce SO_x gas and the combustion process using high excess air and high temperature produces the NO_x pollutant. Limestone or dolomite injected in a wet scrubber or limestone burning in a coal bed has been used to reduce SO_x emissions. NO_x generation can be reduced by decreasing excess air combustion and lowering combustion zone temperature.

A.5.2 Boiler Retrofit

The extent of the retrofitting required to a stoker fired, coal-burning boiler equipment system, in order to successfully burn 100% RDF or RDF as supplemental fuel, will depend upon the following:

- Type of coal being burned.

- Type of stocker grate in the boiler.
- Combustion air supply system of the boiler.
- Induced draft fan capacity of boiler.
- Type of soot blowing in the tube banks.
- Existing ash handling system.
- Type of air pollution control device in the boiler plant.
- Type of furnace wall (waterwall or refractory wall).
- Superheater locations.
- Type of steam load demand and ratings.
- Boiler configuration to accommodate RDF firing scheme (peripheral appurtenances).
- Room for RDF storage, handling, and firing schemes.
- Boiler combustion control system.

A boiler is an integrated assembly of fuel combustion and heat transfer components, each of which can and does affect the operational performance of the other. The combustion chamber of the boiler is designed for a certain heat release rate. For example, for a spreader stoker coal-burning boiler, the heat release rate is 30,000-35,000 Btu/ft³/hr. When a given boiler is being retrofitted to burn 100% RDF or to co-fire RDF with coal, it is important to examine the combustion chamber in terms of residence time, temperature, and turbulence that are essential to achieve complete combustion of fuel (RDF).

The volatile matter content of RDF is much higher than coal (68 to 78% versus 25 to 35%). A furnace configuration designed to burn low volatile coal may therefore be inadequate to accommodate the combustion of a highly reactive fuel like RDF. For a retrofitted spreader stoker boiler, the RDF fuel will be burned partly in suspension and the remainder over the traveling grate. This will produce combustion with long flame travel characteristics. A combustion

chamber wall generally plays a very important part in the combustion and heat absorption phenomena of the furnace. For a low volatile matter fuel like coal, re-radiation from the wall normally aids in the complete combustion of coal. For RDF burning, a water wall furnace is beneficial. The waterwall surface of the combustion chamber plays an important part of heat recovery from a highly reactive fuel like RDF; the waterwall will cool the flame produced from the combustion of RDF to a temperature level that is safe for the flame to travel through the convective tube banks and superheater elements of the boiler. Otherwise severe ash deposits will occur on the boiler and superheater tube banks.

A.5.3 Equipment Subsystem

The first step in retrofitting a coal-burning boiler is to provide an all welded membrane type waterwall enclosure to the combustion chamber. Thus the water-tube walls of the overall boiler system are treated as a separate component of the combustion system while recognizing that they also constitute an important element of the overall boiler. Fortunately almost all recent spreader stoker coal-burning boilers are designed with a water-tube wall combustion chamber and actual retrofitting may not be necessary.

The next step in retrofitting is to provide an appropriate refuse feed inlet in the front wall (coal hopper side) of the boiler. RDF could be fed into the furnace pneumatically or mechanically to ensure successful semisuspension firing. The mechanical feeding scheme proposed in CEL Report No. CR80.005, January 1980 is acceptable if the RDF is moderately dry and the RDF contains no stringy elements. RDF has the tendency to cling together and bridge quickly in the pipeline. Therefore, in order to avoid plugging of pipelines, pneumatic feeding is recommended. In pneumatic feeding, the entrance nozzle of the pneumatic RDF feedpipe is equipped with deflectors to distribute fuel as it enters

the boiler so that it is cast to the rear of the boiler. Deflectors attempt to duplicate the action of a coal spreader. With this type of firing, a good distribution of the fuel and the combustion air is needed. The air feed through the grate helps to achieve good mixing of the fuel and combustion air at a low level in the furnace and to allow the fuel to be combusted with low excess air and low carbon loss. Depending upon the moisture content and particle size distribution of RDF, a burning rate of up to 1,000,000 Btu/ft²/hr of traveling grate could possibly be achieved; for coal, this heat release rate ranges from 450,000 to 750,000 Btu/ft²/hr on traveling grate spreader stokers.

To achieve such a high heat release rate, pneumatic RDF distributors with air swept spouts should be fitted to the boiler furnace. A Riley pneumatic refuse fuel distributor, as used in the Ames, IA facility, is shown in figure A-23. The air swept fuel distributors use a curtain of air which sweeps the floor of the spout and floats fine and light density RDF particles well into the furnace. Motorized rotary dampers provide control of the air supply to each distributor spout by alternately increasing and decreasing both the quantity and pressure of air several cycles per minute to achieve an even distribution from front to rear of the combustion chamber. To provide uniform side-to-side air distribution, several high pressure air jets should be located under each air swept spout¹⁹. Relative locations of air distribution in the Ames, IA facility's traveling grate stoker-fired boiler is shown in figure A-20.

One row of high pressure overfire jets, similar to figure A-22, should be provided to prevent stratification of unburned hydrocarbon gases and vapors originating from the distillation of a high volatile matter content fuel like RDF. These jets should be capable of supplying 15 to 20% of the combustion air and should be located below the pneumatic RDF distributor in the rear and front walls of the boiler furnace. Such overfire jets should be designed to

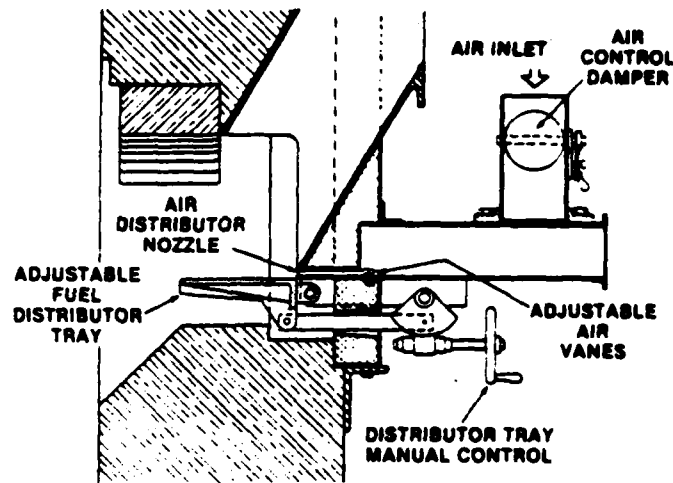

Figure A-23. Riley Pneumatic Refuse Fuel Distributor¹⁹.

cause turbulent mixing of the distilled volatile matter content of RDF with combustion air, thereby inducing burnout of the suspended particles and unburned hydrocarbons. If such mixing does not occur promptly, the rich highly reactive gases are very likely to decompose thermally because of high temperature, thereby releasing fine carbon particles that form smoke and soot. Because of the necessity of prompt and early mixing, the overfire jets should be installed near the fuel bed. Of course, to supply the overfire air, a large fan with associated ducts must be installed as part of the retrofit work²⁰.

For a retrofitted stoker coal-fired boiler burning RDF, the grate speed and underfire air should be adjusted and controlled with appropriate combustion control devices in order to ensure complete combustion of the RDF lying on the grate surface. Since the moisture content of the feed RDF may vary from 15 to 30%, a 100% RDF-burning retrofit boiler should use preheated combustion air. If the retrofit boiler does not have preheated air, installing such equipment is recommended.

The restrictions of burning 100% RDF in a retrofitted stoker coal-fired boiler come from the following factors:

- A coal-burning combustion chamber will be small compared to that required by an ideal dedicated RDF-burning furnace. Normally, it takes more time and consequently more furnace volume to burn RDF than coal.
- The tube spacing will be inadequate for the passage of a high volume of combustion gas. Erosion and slagging will result.
- The ash production will be higher causing strain on existing coal-burning ash-handling equipment.
- The forced draft and induced draft fans of the coal-burning boiler will be inadequate to handle the combustion air (40 to 50% excess) and flue gas volume for 100% RDF, thereby requiring major modifications or system replacement.
- The semisuspension firing of RDF will increase particulate loading to the existing emission control system of the coal-burning boiler, resulting in failure to meet the applicable air emission codes.

For the above reasons, a 100% RDF firing in a retrofitted Navy stoker coal boiler is not recommended. Even the originally designed dedicated RDF boiler plants at Hooker and Akron are experiencing major problems firing 100% RDF.

Considering the above information, it is believed that the use of RDF as supplementary fuel in a boiler seems to have the best prospect for success. Retrofitted refuse and coal burning boilers (numbers 5 and 6) at the Ames Municipal power plant and the dedicated boiler plant to burn industrial refuse and coal at the General Motors Truck and Coach Division plant are good examples of successful installations.

A.5.4 RDF Supplement to Coal

Coarse and fluff RDF have been used as a supplement for coal in stoker coal-fired and pulverized coal-fired boiler furnaces. But as this study is to be based on stoker coal-fired boilers only, it will be useful to examine the performance of units at the Ames and General Motors Truck and Coach Division

plants. Table A-4 shows the design conditions at maximum ratings of boilers at the Ames municipal power plant and the General Motors Truck and Coach Division plant. Fuel characteristics at these plants are shown in table A-5.

The retrofit work for the Ames Municipal plant boilers is similar to what has been discussed in section A.5.2. The boilers were fed with two stages each of shredded, air classified, and magnetically separated refuse. Boilers were operated with refuse to coal ratios of 20 and 50% and at 80 and 100% boiler loads.

Case histories of the operation indicate that RDF in combination with coal could be successfully fired in stoker boilers without major problems. No significant direct effects of burning RDF on measured thermal efficiency were observed. However, pneumatic feeding of RDF increased excess air input to the boiler; as a result, the thermal efficiency of the boiler decreased. There is general consensus among boiler operators that more combustion air though the grate is necessary when firing RDF, to prevent slagging and to maintain a proper fire bed. One boiler, when operated at 100% steam load and 50% RDF, had a severe ash problem due to lack of excess air. At most boiler loads, bottom ash tended to increase somewhat and flyash tended to decrease with increasing percent of RDF. Ash fusion temperatures of RDF are 60 to 100°C lower than for coal. As a result, normal runs of the boiler were adjusted to maintain 80% steam load in mixed-fuel firing⁴.

In specific tests conducted by Battelle Columbus Laboratory involving RDF and coal, co-firing boilers at Ohio Municipal power plants, results were obtained demonstrating the following²²:

- Processed MSW (shredded and magnetically separated) refuse can be handled effectively by available mechanical handling equipment.
- The RDF can be fed successfully into the traveling grate furnace with air-swept spouts.

Table A-4. Design Conditions at Maximum Continuous Rating²¹.*

| Design Parameters | Retrofit Units 5 and 6 Ames Municipal Plant | | Dedicated Co-firing Unit GM Truck and Coach Plant | |
|---|--|-----------------------|--|-------------------------|
| | Refuse/Coal | Coal | Refuse/Coal | Coal |
| Steam flow (lb/hr) | 95,000 | 95,000 | 200,000 | 200,000 |
| Sat. steam pressure (psig) | 710 | 710 | 161 | 161 |
| Outlet superheater pressure (psig) | 630 | 630 | - | - |
| Steam temp. (°F) | 830 | 830 | 371 | 371 |
| Boiler rating (Btu/hr) | 135 x 10 ⁶ | 135 x 10 ⁶ | 170.5 x 10 ⁶ | 170.5 x 10 ⁶ |
| Fuel flow (tons/day) | 175/91 | 182.4 | 300/75 | 240 |
| (tons/hr) | 7.3/3.8 | 7.6 | 12.5/3.2 | 10 |
| (lb/hr) | 14,600/7,600 | 15,200 | 25,000/6,400 | 20,000 |
| Airflow (lb/hr) | 131,600 | Not Available | 281,000 | 252,000 |
| Excess air (%) | 50 | Not Available | 50 | 38 |
| Heat input (Btu/hr) | 73x10 ⁶ / 73x10 ⁶ | 146x10 ⁶ | 187.5x10 ⁶ / 76.6x10 ⁶ | 245x10 ⁶ |
| Fuel heat input (Btu/lb) (as fired basis) | 5,000/9,541 | 9,541 | 7,500/12,500 | 12,500 |
| Furnace heat release rate (Btu/ft ² /hr) | 27,540 | 27,540 | 17,500 | 17,100 |
| Grate heat release rate (Btu/ft ² /hr) | 589,000 | 589,000 | 730,000 | 695,000 |
| Overall unit efficiency (%) | 60 | 80 | 75.6 | 80.98 |
| Refuse energy (%) | 50 | 0 | 70 | 0 |
| Coal energy (%) | 50 | 100 | 30 | 100 |
| Pound of steam/lb of fuel | 4.32 | 6.25 | 6.4 | 10 |

*Both facilities used a spreader stoker, traveling grate furnace; the dust collection equipment used was a multiple cyclone.

Table A-5. City of Ames and G.M. Truck and Coach
Manufacturing Plants Fuel Characteristics²¹.

Ames Municipal Plant Boilers Fuel

General Characteristics of Refuse: (Actual) Corrugated cardboard, rubber and plastic products, aluminum foil and alumina sandpaper, carbon paper, wood chips, glass, sand, stones, other ferrous and nonferrous metals, food waste, yard waste.

Analyses of Prep. RDF: (Actual)

Proximate (as Received)

1/27/78 moisture - 21.3%, volatile - 59.9%,
ash - 14.5%, fixed carbon - 4.3%;
6,355 Btu/lb (14,782 KJ/Kg)

9/75 moisture - 18.7%, volatile - 59.4%,
ash - 14.8%, fixed carbon - 7.2%,
7,046 Btu/lb (16,389 KJ/Kg)

Ultimate

1/27/78 (dry) C - 45.9%, O + Misc. - 29.3%, S - 0.4%,
H - 5.6%, ash - 18.4%, chlorine - 0.4%

10/75 (wet) C - 35.9%, O + Misc. - 23.5%, S - 0.3%,
H - 5.6%, inerts - 24.9%, ash - 9.8%

Ranges of heating values: 4,910 - 8,422 Btu/lb
(11,421 - 19,590 KJ/Kg)

(8/75 - 6/76)

As Received.

Range of moisture content: 15 - 30%

Analyses of Coal Blend: (Actual)

Proximate (as Received)

1/27/78 moisture - 13.8%, volatile - 33.7%,
ash - 12.4%, fixed carbon - 40.1%,
10,697 Btu/lb (24,881 KJ/Kg)

10/75 moisture - 18.76%, volatile - 34.99%,
ash - 8.37%, fixed carbon - 37.88%
9,670 Btu/lb (22,492 KJ/Kg)

Ultimate

1/27/78 (dry) C - 68.5%, O - 7.7%, N - 1.5%,
S - 3.6%, H - 4.3%, ash - 14.4%,
chlorine - 0.026%

10/75 (wet) moisture - 18.76%, C - 54.96%,
O + Misc. - 10.27%, S - 2.17%,
H - 5.47%, ash - 8.37%

Table A-5. City of Ames and G.M. Truck and Coach Manufacturing Plants Fuel Characteristics²¹ (Continued).

G.M. Truck and Coach Manufacturing Plants Fuels

General Characteristics

| | |
|--|---|
| of Raw Refuse: (Design) | wood (42%), paper (33%), cardboard (23%), rubber and plastics (2%) |
| Analyses of Prepared Refuse (Design): | C - 41.5%, O - 34.2%, S - 0.5%, H - 5.9%, Ash - 6.7%, water - 11.2%, 7,500 Btu/lb (17,445 KJ/Kg) as fired. |
| Analyses of Coal (Design): | C - 71.44%, O - 12.6%, S - 0.98%, H - 5.21%, N - 1.69%, ash - 8.08%, 12,250 Btu/lb as fired. Ash fusion temp = 2700°F 45 Hardgrove grindability |
| Prepared Refuse: (Actual) | 7,000 Btu/lb (16,282 KJ/Kg) as fired. |
| Coal: (Actual) | 0.8% sulfur (Present Allowable List) |

- The RDF (nominally 4 inch) will burn completely on the traveling grate.
- Both underfire and overfire air supplies are important in the quality of refuse combustion.
- Aluminum and other low melting metals will melt in the grate.
- The corrosion of boiler tubes from the combustion products produced from co-firing refuse and 3% sulfur coal up to 3:1 weight ratio is slightly higher than for the coal alone; with 5% sulfur coal, it is essentially the same.
- Sulfur oxide emissions can be reduced by the dilution of high sulfur coal with low sulfur RDF.

APPENDIX B
FIELD SURVEY DATA

B.1 GENERAL

One field visit was made to the Ames Municipal Electric Plant, Ames, IA to observe the only utility plant in the United States that has retrofitted stoker coal-fired boilers and uses RDF as a supplementary fuel.

Site visits were made to the following naval installations to observe coal-fired boilers that might be candidates for co-fired consideration:

- Naval Amphibious Base, Little Creek, VA.
- Navy Public Works Center, Naval Base, Norfolk, VA.
- Naval Ordnance Station, Indian Head, MD.
- MCDEC Quantico, VA.

B.2 AMES, IA FACILITY

The only utility plant in the United States that has retrofitted stoker coal-fired boilers and uses RDF as a supplementary fuel is at the Ames Municipal Electric Plant, Ames, IA. The price structure for the sale price of RDF is tied to the price of the coal used by the utility plant, and thus is continuously escalating upward. Recent prices paid for coal FOB Ames Plant are \$50 per ton for low sulfur (0.5%) coal and \$36 per ton of high sulfur washed Iowa coal. In comparison, the sale price of RDF has increased from \$8.83/ton in 1977 to \$16.65/ton in 1981.

The Ames solid waste processing facility and the Municipal Electric plant where the RDF is used as a supplementary fuel to coal were visited. The following persons were contacted:

- Ms. Annette Thompson - Guide, Solid Waste Recovery Plant.
- Don Riggs - Boiler Plant Superintendent.

- Arnold Chantland - Director, Public Works Dept., City of Ames, IA

The solid waste resource recovery plant was designed to process 50 TPH of MSW for 40 hours per week at an annual cost of \$7 million. The simplified flow diagram of the solid waste facility is shown in figure B-1. Some of the observations of the operations of this facility are as follows:

a. The plant receives an average of 160 tons of MSW per day and produces 126 tons of RDF for the boiler plant. The plant now operates on an average of 300 days per year. The plant employs 14 full-time employees. The best operating record was in August 1982 when the plant processed 4,276 tons of MSW. The worst record was in January 1982 when the plant processed only 1,407 tons.

b. Although the resource recovery facility recovers ferrous and non-ferrous metals, at present both of these streams are going to landfill. The cost of scrap iron associated with the ferrous stream is too low to cover the transportation cost. The nonferrous stream is inactive due to technical problems and a similar low scrap value of products. In addition, the plant was also designed to sort out and bale papers; that operation is also closed now. No profitable market for waste paper exists.

c. The capitalization, materials, revenue and expenses, and other recent operating data (1980 to '81) are shown in tables B-1 through B-4. It is noted from table B-2 that the RDF producing plant is recovering only 45% of the total expense of the plant. Table B-3 is useful in examining the operating and maintenance cost breakdown.

d. In the power plant that uses the RDF, the number 5 and number 6 stoker coal-fired boilers that were retrofitted are now used as standby 100% coal-fired boilers only. Presently, RDF is being used in the number 7 and number 8 pulverized coal-fired boilers. The number 8 boiler was designed to accept up to 20% of the boiler energy input from RDF. In operation, number 5

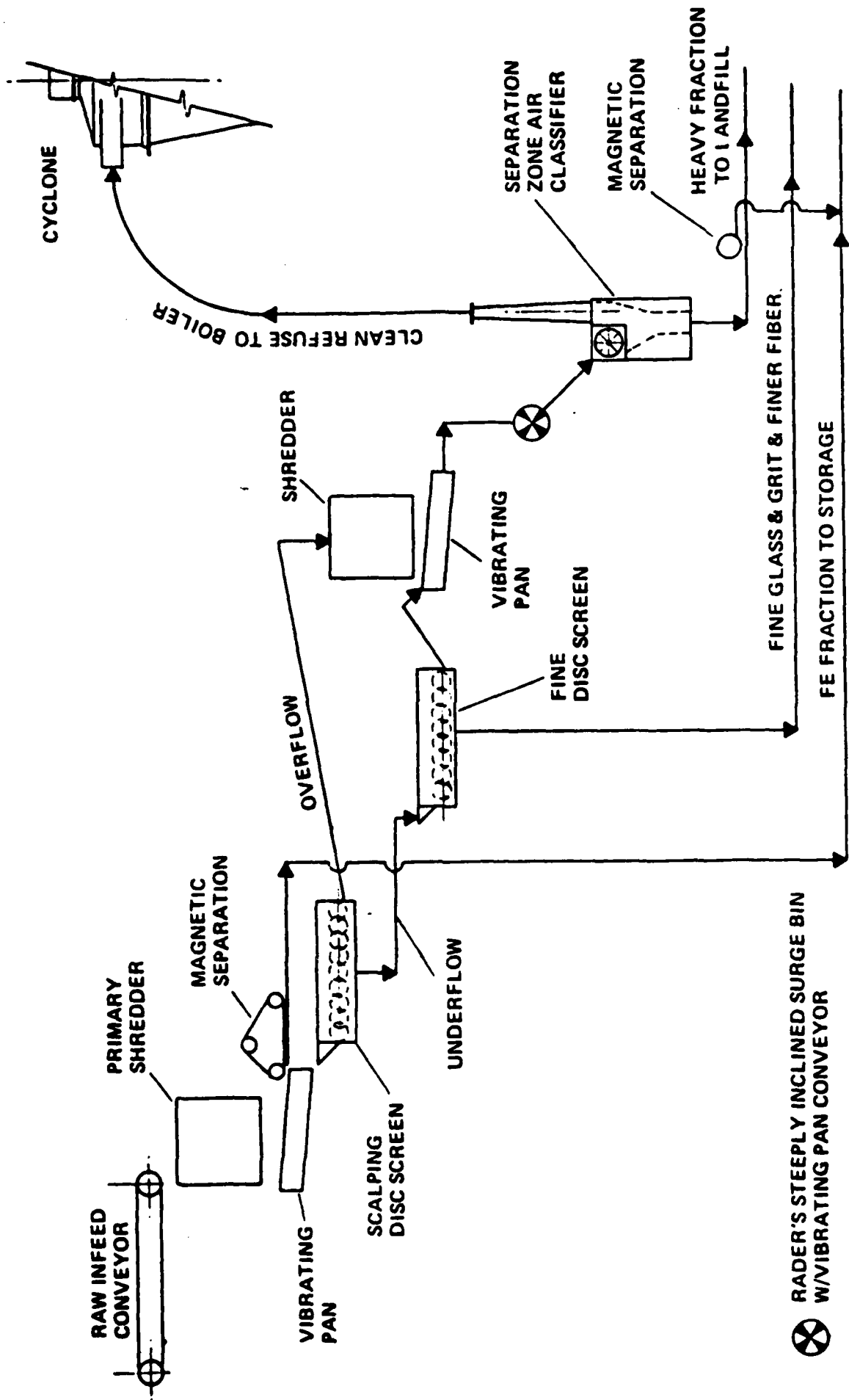

Figure B-1. The Ames Recovery System^{2,3}

Table B-1. Capitalization: Ames Refuse Derived Fuel
Production Facilities²³ .

| | | | |
|--|----------------|-------------|-------------|
| <u>Processing equipment (1973 dollars)</u> | | | |
| Shredding system (include conveyors) | \$304,000 | | |
| Ferrous separators | 69,282 | | |
| Air density separator | 182,854 | | |
| Incoming refuse scale | 32,769 | | |
| Other plant conveyors | 104,600 | | |
| Plant crane | 24,520 | | |
| Pneumatic conveyor of RDF | 30,017 | | |
| Electric substation & motor starters | 97,343 | | |
| Non-ferrous separation system | 251,130 | | |
| Wood chipper | <u>32,319</u> | | |
| | Sub-total | \$1,128,834 | |
| <u>Building and installation of equipment (1974 dollars)</u> | | | |
| Structure | \$1,980,664 | | |
| Mechanical (include equipment installation) | 414,105 | | |
| Electrical | <u>314,020</u> | | |
| | Sub-total | \$2,708,789 | |
| Land | 107,841 | | |
| Engineering (process plant) | <u>278,903</u> | | |
| | Sub-total | \$386,744 | |
| Total Process Plant | | \$4,224,367 | |
| <u>Power Plant Conversion and RDF Storage (1974 Dollars)</u> | | | |
| Storage bin | \$656,428 | | |
| Boiler modifications | 178,989 | | |
| Land (no charge) | -0- | | |
| Pneumatic conveying systems- | 134,371 | | |
| Mechanical | 188,479 | | |
| Electrical | 342,867 | | |
| Engineering | <u>97,993</u> | | |
| Total Power Plant and Storage | | \$1,599,127 | |
| <u>Plant start-up (1975 dollars)</u> | | | |
| Miscellaneous equipment (loader, trailer tools, etc.) | 164,827 | | |
| Operation (4 month shake-down) | 71,603 | | |
| Interim financing (mostly interest) | <u>249,975</u> | | |
| Start-up costs | | 486,405 | |
| Total original capital costs | | | \$6,309,899 |
| <u>Facilities modification costs (major items, 1978)</u> | | | |
| Dump grate Boiler #1 | \$113,380 | | |
| Disc screen system | 232,003 | | |
| Dust collection system | <u>165,592</u> | | |
| | | 510,975 | |
| Total Capital Investment | | | \$6,820,874 |

Table B-2. City of Ames, Iowa, Solid Waste Comparative Statement²³

Statement "A-1"
Calendar 1981

| | 1977 | 1978 | 1979 | 1980 | 1981 | \$ PER CAPITA |
|------------------------------|--------------|--------------|--------------|--------------|--------------|------------------|
| REVENUE: | | | | | | |
| Refuse Sale for Fuel | \$353,326.99 | \$322,344.03 | \$305,421.58 | \$380,002.66 | \$444,630.75 | \$ 7.49 |
| Sale of Metals | 102,323.23 | 89,270.45 | 78,604.19 | 77,094.59 | 80,643.32 | 1.36 |
| Public Fees | 11,841.62 | 12,595.38 | 11,397.03 | 19,299.90 | 19,042.53 | .32 |
| Regular Customers | 13,653.26 | 15,206.65 | 12,370.35 | 27,640.67 | 27,538.00 | .46 |
| Woodchips | 2,792.23 | 962.24 | 727.87 | 1,598.67 | 1,254.08 | .02 |
| Paper Recycling | 7,416.00 | 2,225.34 | 472.60 | 910.80 | 190.78 | .00 |
| Sanitary Landfill | 24,124.74 | 33,590.00 | 29,879.02 | 40,513.10 | 23,182.64 | .39 |
| Reimbursement and Refunds | 7,273.39 | 9,570.32 | 10,737.45 | 2,376.08 | 987.79 | .02 |
| Other Governmental Units (1) | 5,817.79 | 8,925.48 | 8,309.86 | 12,183.16 | 13,488.12 | .23 |
| Sales of Scrap Iron | | | | | 5,392.85 | .09 |
| Scrap Tires | | | | | 718.50 | .01 |
| I.S.U. Participation | 91,494.48 | 116,309.13 | 140,464.18 | 116,643.47 | 109,633.26 | 1.85 |
| Total Revenue | \$620,063.73 | \$610,999.02 | \$598,404.13 | \$678,265.10 | \$726,704.62 | \$12.24 |

*Due to rounding, the sum of parts does not equal this whole.

| | 1977 | 1978 | 1979 | 1980 | 1981 | \$ PER CAPITA |
|----------------------|----------------|----------------|----------------|----------------|----------------|------------------|
| EXPENDITURES: | | | | | | |
| Operations | \$638,717.60 | \$637,345.87 | \$737,234.87 | \$1,002,570.41 | \$807,818.97 | \$13.61 |
| Start-up Charges (2) | 52,183.45 | 52,183.45 | 52,183.44 | | | .96 |
| Bond Interest | 265,352.51 | 263,593.63 | 245,600.00 | 229,350.00 | 209,850.00 | 3.54 |
| Bond Principal | 200,000.00 | 200,000.00 | 200,000.00 | 300,000.00 | 300,000.00 | 5.05 |
| Equipment Reserve | 12,500.00 | 12,500.00 | 12,500.00 | 12,500.00 | 12,500.00 | .21 |
| Total Expenditures | \$1,168,753.56 | \$1,165,625.95 | \$1,247,518.31 | \$1,544,420.41 | \$1,330,168.97 | \$22.41* |

| | 1977 | 1978 | 1979 | 1980 | 1981 | \$ PER CAPITA |
|-----------------------------------|--------------|--------------|--------------|--------------|--------------|------------------|
| To Be Shared | \$548,689.83 | \$554,625.93 | \$649,114.18 | \$866,155.31 | \$603,464.35 | |
| Processed MSW | 48,381 Tons | 37,720 Tons | 32,010 Tons | 40,076 Tons | 41,011 Tons | |
| RDY Produced | 40,890 Tons | 28,488 Tons | 23,059 Tons | 26,777 Tons | 26,818 Tons | |
| Gross Sales per Ton of RDY Snd | \$8.83/Ton | \$11.30/Ton | \$13.20/Ton | \$14.20/Ton | \$16.65/Ton | |
| Gross Revenue per Ton of MSW | \$12.62/Ton | \$16.20/Ton | \$18.69/Ton | \$16.92/Ton | \$17.72/Ton | |

Table B-3. Ames Solid Waste Recovery System Materials, Revenues and Expenses
for Plant Operation¹.

| Year | Tons Avail | Process Tons | (%) | Ferrous Tons | RDF Tons | Revenue | Expense | Percent Rev./Exp. |
|--------------|------------|--------------|------|--------------|----------|-----------|-------------|-------------------|
| 1976 | 52,000 | 40,936 | 78.7 | 2,868 | 34,464 | \$448,721 | \$1,033,186 | 43.4 |
| 1977 | 56,780 | 48,381 | 85.2 | 3,008 | 40,890 | 498,626 | 1,047,734 | 47.6 |
| 1978 | 50,520 | 37,720 | 74.7 | 2,380 | 28,488 | 448,227 | 1,022,632 | 43.8 |
| 1979 | 49,096 | 32,010 | 65.2 | 1,558 | 23,059 | 413,253 | 1,230,677 | 33.6 |
| 1980 | 43,684 | 40,076 | 91.7 | 1,794 | 26,797 | 659,375 | 1,397,334 | 47.2 |
| 1981 | 41,790 | 41,011 | 98.1 | 2,151 | 26,771 | 572,982 | 1,274,744 | 45.0 |
| 6-year Total | 293,870 | 240,134 | | 13,759 | 180,469 | 3,041,184 | 7,006,307 | |

Six Year Averages

| | |
|------------------------------|---------|
| \$/incoming ton revenue | \$12.66 |
| \$/incoming ton expense, net | 16.52 |
| % recovery - RDF | 75.2% |
| % recovery - ferrous | 5.7% |

Table B-4. City of Ames Solid Waste Recovery System
Data Report thru Fourth Quarter²³ .

| DATA ITEM | PERIOD ENDING 12-31 | | AMOUNT OF CHANGE |
|------------------------------------|---------------------|------------------|---------------------|
| | 1980 | 1981 | |
| Raw Refuse Received | 40,076 | 41,011 | 935 |
| Materials Separated | <u>(13,296)</u> | <u>(14,240)</u> | (944) |
| Net RDF to Storage Bin | 26,780 | 26,771 | (9) |
| Operating Revenues | 551,396 | 603,342 | 51,946 |
| Operating Expenses | <u>(1,002,570)</u> | <u>(807,819)</u> | 194,751 |
| Net Operating Results | <u>(451,174)</u> | <u>(204,477)</u> | 246,697 |
| Non-Operating Revenues | 340,663 | 132,354 | (208,309) |
| Non-Operating Expenses | <u>(541,850)</u> | <u>(522,350)</u> | 19,500 |
| Total Net Results | <u>(652,361)</u> | <u>(594,473)</u> | 57,888 |
| Operating Revenue Detail: | | | |
| RDF Credits | 380,003 | 444,631 | 64,628 |
| Metal Sales | 77,095 | 80,643 | 3,548 |
| Wood Sales | 1,599 | 1,254 | (345) |
| Plant Fees | 46,941 | 46,341 | (600) |
| Misc. Revenues | 5,245 | 7,290 | 2,045 |
| Landfill Fees | 40,513 | 23,183 | (17,330) |
| Non-Operating Revenue Detail | | | |
| Oil Entitlements | 171,834 | | (171,834) |
| Governments, EPA and Adjustments | 170,787 | 132,354 | (38,433) |
| Operating Expense Detail | | | |
| Shredder Maint. | 73,700 | 50,660 | (23,040) |
| Degritting System Maint. | 21,521 | 21,575 | 54 |
| Tipping Floor Operation | 98,557 | 57,484 | (41,073) |
| Conveyor Maint. | 36,923 | 28,059 | (8,864) |
| Equip. Rent (Plant Only) | 66,403 | 59,635 | (6,768) |
| Fire Insurance | 28,529 | 17,094 | (11,435) |
| Metal Shipping | 46,070 | 47,362 | 1,292 |
| City Utilities | 147,077 | 139,282 | (7,795) |
| Other Plant Operations | 362,394 | 314,906 | (47,488) |
| Landfill Operations | 121,396 | 71,762 | (49,634) |
| Non-Operating Expense Detail | | | |
| Bond Principal and Interest | 529,350 | 509,850 | (19,500) |
| Equipment Reserve | 12,500 | 12,500 | 0 |
| Electric Power Consumption (KWHr.) | 2,306,627 | 2,052,826 | (253,801) |

and number 6 boilers had a high degree of fouling of the superheater sections.

These boilers were not equipped with soot blowers at the superheater tubes.

The boiler plant superintendent commented as follows:

- 20% RDF and 80% coal works well.
- 50% high sulfur coal and 50% RDF operation does not meet EPA's SO_x emission code.
- Low sulfur coal produces powdery ash that disintegrates on the grate and plugs the air holes resulting in the grate becoming too hot. At least a 2-inch deep ash bed is needed for continued operation.
- The combustion chambers of number 5 and number 6 boilers are too small to burn 100% RDF. 50% RDF has been burned for a long time but the fouling problem was too severe.
- 20 to 22% of the furnace wall tubes in the furnace grate region had to be replaced after the first year of operation due to severe concentration of oxygen-rich gases in the region. The problem was remedied by putting refractory covers over the tubes.
- Maintenance cost for RDF storage and feeding Atlas bin was originally \$125,000/year. With experience and improved approaches it has been decreased to \$61,000/year.
- For 1981, maintenance cost for RDF and coal firing combined was \$121,900 per year.
- Typical co-firing data:

Number 6 Boiler: Combustion Chamber Volume - 6650 cubic feet

Heat Rate - 18,353 Btu/kW

Energy Production - 200,000 kW/day

Total energy output = 3.67×10^9 Btu/day
= 153×10^6 Btu/hr

RDF = 278,400 lb/day @ 6,140 Btu/lb

Coal - IA, high sulfur - 113,800 lb/day @ 9,500 Btu/lb

WY low sulfur - 113,800 lb/day @ 12,500 Btu/lb

Steam rate - 10.88 lb/kW

RDF as % of total energy output = 46.55%

The meeting with Mr. Chantland provided an inside view of the RDF plant operation. Some of the major problems encountered during the startup phase were as follows:

- Excessive combustibles at the pulverized boiler.
- Excessive wear and noncombustible ash at stoker boiler.
- Excessive dust in the processing area.
- Storage bin operating problem.
- Excessive wear on the floor of the refuse-derived fuel storage bin.
- Excessive fouling of the tubing.
- Unprofitable market for recovery materials.
- High maintenance cost of the shredder and air classifier.
- RDF use at present is at the level of 20% energy input to the boiler.

The overall economic picture of the Ames project is shown in table B-4. Past experience showed that a retrofitted stoker fired, coal-burning boiler at the Ames plant can operationally use up to 20% of the energy input from RDF.

B.3 Naval Installations

Annex I through IV provide the summary of data obtained during the site visits to four naval activities operating coal-fired boilers.

In three cases, the boiler plants were in the process of converting from oil/coal to 100% coal. In the fourth case, Navy Public Works Center Norfolk, the boiler is new and is being activated to burn pulverized coal.

APPENDIX I

NAVY FACILITY SITE VISIT DATA

Date of Plant Visit: 3 December 1983

Station: Naval Amphibious Base, Little Creek, Virginia

• Boiler Inventory: Three Wickes 100 MBtu/hour boilers (1956)

• Originally designed to burn coal

• Fuel:

• Primary Residual oil • Secondary Coal • Dual Oil and Coal

• Steam Production:

• Annual Gross Production: 740,000 MBtu/year

• Pressure 326 Design psig (saturated/superheated) 280 psig operational

• High Average Flow Rate 120,000 pounds/hour

• Low Average Flow Rate 50,000 pounds/hour

• Annual Gross Cost of Production \$6,295,000

• Coal Preparation, if any: Roto grate stoker boiler. Size of coal used:
top--1-1/4" to 3/4", bottom - 1/4"

• Foundation: Floor ; Floor Ash Pit: Yes

• Ash Hopper: Yes ; Ash Handling System: Yes

Description of Ash Handling System: Each boiler has own pneumatic (vacuum) ash removal and handling system.

• APC System: One bag house for each boiler

• Make-up Water: 20% Condensate Return: In plant use of steam is returned

• Special Features of Boiler System: Exhaust gas temperature = 430°F.

WWHS = 2,224 ft², Boiler HS = 9,611 ft². Has air handler and economizer.

• Boiler Plant Retrofit Conditions: Adequate

• Adequacy of Area Outside Plant: Ample space

• Other: Plant is in the process of converting to coal as the primary fuel.

APPENDIX II

NAVY FACILITY SITE VISIT DATA

Date of Plant Visit: 1 December 1982

Station: Navy Public Works Center, Norfolk, Virginia--Building P-1

- Boiler Inventory: Three Riley Stoker, 75 MBtu/hour boilers (1941)
Three Combustion Engineering 100 MBtu/hour boilers (1942)
One Combustion Engineering 115 MBtu/hour boiler (1945)
One Riley 200 MBtu/hour boiler (new)
 - Originally designed to burn 5 coal, 3 oil
 - Fuel: 7 Res. Oil 4 Coal
• Primary 1 Pulv. Coal • Secondary 4 None • Dual Res. Oil/Pulv. Coal
 - Steam Production:
• Annual Gross Production: 2,665,000 MBtu/year
• Pressure * psig (saturated/superheated)
• High Average Flow Rate 280,000 pounds/hour
• Low Average Flow Rate 120,000 pounds/hour
• Annual Gross Cost of Production \$28,500,000
 - Coal Preparation, if any: 2 pulverizers per boiler.
-
- Foundation: 7 pier, 1 hung ; Floor Ash Pit: 5 yes; 3 no, Ash removal door
at floor level
 - Ash Hopper: 5 Yes, 3 No ; Ash Handling System: 5 Yes, 3 No
Description of Ash Handling System: Pneumatic vacuum system. Only one system
with 200 MBtu/hour Riley is operative.
-
- APC System: 4 ESP & Multicyclone, 1 ESP & Cyclone, 3 None
 - Make-up Water: 100% Condensate Return: None
 - Special Features of Boiler System: The tubes in the four Comb. Eng. boilers
would have to be rerouted to install dump grates. The 3 small Riley stokers
all have ash removal doors at floor level.
-
- Boiler Plant Retrofit Conditions: Extremely congested. Considerable
difficulty would be experienced attempting to route RDF lines through plant.
-
- Adequacy of Area Outside Plant: Marginal. Coal storage space would have
to be decreased to provide RDF storage facilities.
-
- Other: Note: * 4 boilers--425 psig superheated at 565°F.
2 boilers--340 psig saturated
1 boiler--125 psig saturated
-
- Do not recommend conversion of seven older boilers to co-fired RDF and oil
due to age and condition of units.

APPENDIX III

NAVY FACILITY SITE VISIT DATA

Date of Plant Visit: 16 February 1983

Station: Naval Ordnance Station, Indian Head, Maryland

- Boiler Inventory: Three Combustion Engineering 189 MBtu/hour boilers (1954)

- Originally designed to burn Coal and oil
- Fuel:
 - Primary Pulv. coal • Secondary Residual oil • Dual Coal and oil
- Steam Production:
 - Annual Gross Production: 1,010,000 MBtu/year
 - Pressure 900 psig (saturated/superheated) at 825°F.
 - High Average Flow Rate 180,000 pounds/hour
 - Low Average Flow Rate 105,000 pounds/hour
 - Annual Gross Cost of Production \$9,000,000
- Coal Preparation, if any: Two pulverizers per boiler. Use 1/2" pulverized coal.

- Foundation: Pier-hung ; Floor Ash Pit: Yes
- Ash Hopper: Yes ; Ash Handling System: Yes, 5 tons/hour capacity
Description of Ash Handling System: Fly ash reinjection system. Ash is collected first at last pass of boiler, then at air heater pass, then at mechanical cyclone. Coal w/10% ash is burned. Ash handling system is a vacuum system. The ash has to be manually removed from hoppers.
- APC System: Mechanical cyclone. Three ESPs are to be installed.
- Make-up Water: 100% Condensate Return: _____
- Special Features of Boiler System: Plant is designed to produce electricity (10 MW capacity) and extract steam for heat. Each boiler is fitted with dual firing coal and oil burners. New controls have been ordered. Combustion chamber volume = 9,295 ft³, HTG surface = 11,870 ft², WW HTG surface = 5,105 ft²
- Boiler Plant Retrofit Conditions: Adequate

- Adequacy of Area Outside Plant: Ample

- Other: Plant is very clean and appears to be in excellent condition even though boilers are nearly 30 years old.

APPENDIX IV

NAVY FACILITY SITE VISIT DATA

Date of Plant Visit: 17 February 1983

Station: MARCORPS Development and Education Command, Quantico, Virginia

- Boiler Inventory: Two Combustion Engineering 61 MBtu/hour boilers (1938)
One Riley Stoker 67 MBtu/hour boiler (1947)
One Riley Stoker 146 MBtu/hour boiler (1945)
Two Henry Vogt 68 MBtu/hour boilers (1929) *
- Originally designed to burn coal
- Fuel:
• Primary Coal • Secondary Residual Oil • Dual _____
- Steam Production:
• Annual Gross Production: _____ 1,380,000 MBtu/year
• Pressure _____ - 120 psig (saturated/superheated)
• High Average Flow Rate _____ 160,000 pounds/hour
• Low Average Flow Rate _____ 50,000 pounds/hour
• Annual Gross Cost of Production Not available
- Coal Preparation, if any: Two pulverizers per boiler. 3/4" to 1" coal used.
- Foundation: Floor _____ ; Floor Ash Pit: No
- Ash Hopper: No _____ ; Ash Handling System: Yes
Description of Ash Handling System: Ash is manually drawn to vacuum ash handling system.
- APC System: ESP system being installed.
- Make-up Water: 50% Condensate Return: 50%
- Special Features of Boiler System: The boilers do have preheaters. Combustion chamber volumes for two CE boilers = 2,500 ft³, one Riley Stoker = 2,700 ft³, and one Riley Stoker = 5,600 ft³
- Boiler Plant Retrofit Conditions: Congested area. Would be difficult to route RDF feed system.
- Adequacy of Area Outside Plant: Adequate
- Other: Note: * Two Henry Vogt boilers being removed.
Do not recommend conversion to co-fired RDF and oil due to age and condition of boilers.

APPENDIX C
ECONOMIC ANALYSES

C.1 GENERAL

Life cycle economic analyses are presented for retrofitting and operating generic boiler plants with capacities ranging from 100 MBtu/hr to 450 MBtu/hr.

Special provisions have been made to consider the option of a contractor owned MSW processing plant to be constructed onboard the Naval base within 1/2 mile of the boiler plant. The criteria and cost parameters surrounding that option are treated in annex I.

The general economic parameters used in this study are based upon the following assumptions:

- a. The load factor per boiler was assumed to be equal to 0.75 based on 24 hour per day operations, 305 days per year, producing steam at 90% capacity.
- b. The economic life of the retrofitted boiler is 20 years.
- c. The fuel mix will be 50% RDF/50% coal as a function of energy input.
- d. The RDF receiving, storage, and charging systems are designed as shown in figure 4-5.
- e. The purchase price of RDF will include delivery costs.
- f. The prepared RDF used in this analysis will have a heating value of 5625 Btu/lb (as received) with moisture content no greater than 20% by weight and ash content no greater than 15% by weight. The RDF will meet the specifications established in section 4.1.1.
- g. The thermal efficiency of the existing Navy coal fired boilers retrofitted to a cofiring (coal and RDF) process is 72%. For 100% coal-fired, 78% efficiency is used.
- h. As-fired coal cost is \$42 per ton based upon 1983 projected mid-Atlantic contract rates.
- i. Construction period for the RDF storage and retrieval facilities and boiler retrofit system is 2 years based upon the concept that a contractor MSW processing plant would be erected on the naval base which would take 2 years to complete.

j. The design, engineering, installation, and operating expenses related to the handling, storage, and retrieval of the RDF at the boiler plant site will be borne by the Navy.

k. The total capital investment cost (the Navy obligations only) shall include:

- Installed equipment
- Support facilities (support structure, utilities hookup etc.)
- Contingency @ 10% of facilities estimate
- Facility design engineering fee at 8%

l. The incremental cost (labor and materials supplies) associated with the operation and maintenance of the RDF storage, handling, and retrieval systems which are used in the analyses are detailed in the case studies.

m. Capital investment costs and O&M costs will be treated using a cost of capital of 10% and normal inflation, as outlined in the Economic Analysis Handbook, NAVFAC P-442, July 1980. The exception will be coal which will be treated as inflating at a rate of 2% faster than normal inflation.

n. Plant operations were considered to be changed with either the introduction or variance in usage of RDF.

o. Plant maintenance is varied to account for different levels of plant and equipment upkeep and increased equipment wear.

p. Boilers are treated as rated at full design capacity; i.e. no derating is planned.

q. All costs used in these analyses are in terms of 1983 dollars.

C.2 MSW PROCESSING PLANT

One option considered was to provide for a contractor owned and operated MSW processing plant to be erected within 1/2 mile of the Navy boiler plant on Navy property.

A basic design is provided for the proposed MSW processing facility to produce RDF-2 fuel at a rate of 235 tons per day (single shift) or 470 tons per day (double shift), 5 days per week, 52 weeks per year. Annex I includes a detailed description of the design concept as well as a proposed plant layout.

The processing plant as designed would produce 61,000 tons per year of RDF-2 with a single shift operation or 122,000 tons per year with a double shift operation.

The capital investment cost would equal:

- \$3.6 million for MSW processing equipment.
- \$4.3 million for facilities.

Converting the capital investment costs to an annual recovery charge and combining with the cost to operate and maintain the processing plant would produce RDF costs approximating those shown in table C-1.

The unit price per ton of RDF delivered drops drastically when the plant goes from single-shift to double-shift operations. The net effect is to spread the capital investment costs over a much larger base. Two other areas have major impact on any decision relative to using RDF; i.e.:

- Tipping fee charges at MSW Processing Plants are normally equal to the cost of the alternative means of refuse disposal. Therefore, this revenue factor becomes very site specific and can have a major impact on the unit cost of the RDF. Wherein the Navy trash generated by a Naval installation ranges from 6,000 to 18,000 tons per year dependent upon location, it becomes readily apparent that the majority of the solid waste will come from the municipality. Their alternate cost will become the governing factor determining the tipping fee rate.
- The decision to expand the maintenance, repair, and overhaul programs on installed equipment requires detailed analysis. RDF equipment can be expected to last 20 years in many cases with an expanded maintenance program. In other cases equipment replacement may be necessary. As a test case, case 2 in annex II was treated considering both expanding the maintenance programs and replacing the RDF processing equipment. The net effect in case 2, of replacing the RDF equipment versus expanding the maintenance, would be to increase the unit cost, table C-1, by \$1.44 per ton. The accelerated maintenance and repair alternative would increase the unit cost factor, table C-1, by \$0.76/ton had that concept been adopted.

C.3 CONCEPT OF OPERATIONS

The basic concept of operations provides for:

- Retrofitting two boilers for a plant with three or four boilers.

Table C-1. MSW Processing Plant Operations and Product Cost
(35 TPH Operation).

| Cost Factor | Annual Cost (First 10 Years) | |
|---|------------------------------|----------------------------|
| | 235 TPD Single Shift | 470 TPD Double Shift |
| <u>Operations Costs</u> | | |
| Labor | \$192,000 | \$384,000 |
| Fuel | 15,000 | 30,000 |
| Material | 25,000 | 50,000 |
| <u>Maintenance Costs</u> | | |
| Labor | 64,000 | 96,000 |
| Materials | 160,000 | 200,000 |
| Contracts | 0 | 0 |
| <u>Utilities</u> | | |
| Electricity | 77,000 | 122,000 |
| Water | 50,000 | 100,000 |
| Landfill disposal | 30,000 | 60,000 |
| <u>Subtotal - Direct</u> | \$613,000 | \$1,042,000 |
| <u>Overhead</u> | | |
| Supervision | 29,000 | 58,000 |
| Administrative | 57,000 | 54,000 |
| Payroll Acceleration | 106,000 | 184,000 |
| Insurance | 40,000 | 40,000 |
| Taxes | 160,000 | 160,000 |
| G&A | 160,000 | 160,000 |
| Capital Invest. Charge | 1,003,000 | 1,003,000 |
| <u>Subtotal - Overhead</u> | \$1,555,000 | \$1,659,000 |
| <u>Total - Direct and Overhead</u> | 2,168,000 | 2,701,000 |
| <u>Less Credits</u> | | |
| Tipping Fee @ \$15/Ton (MSW Tons x \$15) | (1,090,000) | (2,179,095) |
| Ferrous Metals @ \$15/Ton (MSW Tons x 0.0461 x \$15) | (50,000) | (100,456) |
| <u>Subtotal Credits</u> | (\$1,140,000) | (279,551) |
| <u>Net Production Costs</u> | 1,028,000 | 422,000 |
| <u>Profit (16% of Gross Cost)</u> | 347,000 | 432,000 |
| <u>Total Production Cost</u> | \$1,375,000 | \$854,000 |
| <u>Cost per Ton of RDF</u> | 22.54/ton | 7.00/ton |
| <u>Cost per 10⁶ Btu</u> | \$ 2.78/10 ⁶ Btu | \$0.86/10 ⁶ Btu |

- Retrofitting three boilers for a plant having five or more boilers.

In a site specific analysis, the total plant production would have to be considered to be a product of firing both the retrofitted co-fired boilers and the standby fossil fuel-fired boiler. For the generic analyses, however, the total plant production will be assumed to be generated by the retrofitted boilers only. RDF will be assumed to be purchased without regard to location of processing plant.

C.4 PLANT OPERATIONS

The RDF consumption per day or per year can be stated in terms of:

$$W_R = \frac{Q_o \times t}{Be_2} \times \frac{1}{HHV_R \times 2000 \text{ lbs/ton}} \times CF \times P_R$$

where: W_R = weight of RDF in tons/year
 Q_o = energy output of boiler in MBtu/hour
 t = time period = 24 hours/day
 Be_2 = boiler efficiency for 50% RDF/50% coal
= 72%
 HHV_R = high heat value of RDF = 5,625 Btu/lb
 CF = capacity factor = 90% of capacity (av. operations)
 P_R = percent RDF

For one 50 MBtu/hr (output) boiler:

$$W_R = \frac{50 \times 10^6 \times 24}{0.72} \times \frac{1}{5,625 \times 2000} \times 0.9 \times 0.5$$

$$W_R = 66.67 \text{ tons/day}$$

Annual RDF consumption for a 50 MBtu/hr boiler, assuming an operation of 305 days per year:

$$W_R = 66.67 \text{ tons/day} \times 305 \text{ days/yr}$$

$$W_R = 20,332 \text{ tons/yr}$$

The daily coal consumption per boiler would be:

$$W_c = \frac{Q_o \times t}{Be_2} \times \frac{1}{HHV_o \times 2000 \text{ lb/ton}} \times CF \times P_c$$

where: W_c = weight of coal

HHV_c = high heat valve of coal = 12,500 Btu/lb

P_c = percent coal

For one 50 MBtu/hr (output) boiler:

$$W_c = \frac{50 \times 10^6 \times 24}{0.72} \times \frac{1}{12,500 \times 2000} \times 0.9 \times 0.5$$

$$= 30 \text{ tons/day}$$

Annual coal consumption, assuming 305 days of operation per year:

$$W_c = 30 \text{ tons/day} \times 305 \text{ days/yr}$$

$$= 9,150 \text{ ton/yr}$$

Coal saved as a result of the co-firing of RDF and coal, versus coal alone, would equal:

$$W_c \text{ (saved)} = W_c \text{ (100\% coal-fired)} - W_c \text{ (50\% RDF/50\% coal-fired)}$$

where:

$$W_c \text{ (100\% coal-fired)} + \frac{Q_o \times t}{Be_1} \times \frac{1}{HHV_c \times 2000 \text{ lb/ton}} \times CF$$

$$= \frac{50 \times 10^6 \times 24}{0.78} \times \frac{1}{12,500 \times 2000} \times 0.9$$

= 55.38 tons/day

= 16,891 tons/yr

W_c (saved) = 16,891 tons/yr - 9,150 tons/yr

W_c (saved) = 7,741 tons/yr (for one 50 MBtu/hr boiler)

Table C-2 provides a summary of gross production, fuel consumption, and fuel savings for boilers operating 24 hours per day, 305 days per year, 50% RDF and 50% coal, 72% boiler efficiency, at 90% of boiler capacity, and no derating.

Table C-2. Boiler Operations Summary.

| Number of Boilers | Boiler Capacity (MBtu/hr) | Gross Production (MBtu/yr) | Fuel Consumption | | Coal Saved (Tons/Yr) |
|-------------------|---------------------------|----------------------------|------------------|----------------|----------------------|
| | | | RDF (Tons/Yr) | Coal (Tons/Yr) | |
| 2 | 50 | 658,752 | 40,664 | 18,299 | 15,482 |
| 2 | 75 | 988,128 | 59,347 | 26,706 | 21,495 |
| 2 | 100 | 1,317,504 | 81,327 | 36,597 | 30,967 |
| 2 | 150 | 1,976,256 | 121,491 | 54,896 | 46,450 |
| 3 | 150 | 2,964,384 | 182,987 | 82,344 | 69,676 |

C.5 ECONOMIC EVALUATION

C.5.1 Economic Model

The basic economic model can be stated in terms of:

$$\text{Cost}_{DC} \times \frac{DF_C}{DF_N} = \text{Cost}_{RDF} + \frac{NPV(I)}{DF_N} + \frac{NPV(IR)}{DF_N} + \Delta \text{ OPS} + \Delta \text{ MAINT} - \Delta \text{ SWR} + \Delta \text{ OTHER}$$

where: Cost_{DC} = total cost of displaced coal
 DF_C = 20-year discount factor for (year 22 - year 2) coal @ +2% inflation = 8.873
 DF_N = 20-year normal discount factor (year 22 - year 2) @ base inflation = 7.382

- $Cost_{RDF}$ = total cost of RDF
 $NPV(I)$ = Net Present Value of capital investment
 $NPV(IR)$ = Net Present Value of cost of equipment replacement
 ΔOps = change in operations costs as a result of co-firing boilers
 $\Delta Maint$ = change in maintenance costs
 ΔSWR = savings in solid waste removal
 $\Delta Other$ = other increases or decreases caused as a result of co-firing boilers

The costs of displaced coal is multiplied by DF_C/DF_N to account for coal inflating at a rate 2% faster than normal inflation. $NPV(I)$ and $NPV(IR)$ are divided by DF_N to reduce the total net present costs to annual capital cost recovery charges.

The cost of displaced coal ($Cost_{DC}$) x DF_C/DF_N - the cost of RDF ($Cost_{RDF}$) represents the AFCS.

The AFCS for a plant can also be stated as a direct function of fuel consumption:

$$AFCS = \frac{Q_o}{Be_1} (T \times LF) \frac{(C_c DF_c)}{DF_N} - \frac{Q_o}{Be_2} (T \times LF) (P_c C_c \frac{DF_c}{DF_N}) - \frac{Q_o}{Be_2} (T \times LF) (P_R C_R)$$

- where: Q_o = capacity of boiler(s) in terms of Btu/hr
 Be_1 = boiler efficiency, coal only
 Be_2 = boiler efficiency, co-fired
 T = hours per year = 8,760
 LF = load factor = percent use x operating level; i.e.
 83% use @ 90% capacity = 0.75
 P_R = percent Btu input from RDF
 C_R = cost of RDF per 10^6 Btu input

| | |
|--------|---|
| P_c | = percent Btu input from coal |
| C_c | = cost of coal per 10^6 Btu input |
| DF_c | = 20 yr discount factor for coal @ + 2% inflation = 8.873 |
| DF_N | = 20 yr normal discount factor @ Base Inflation Rate = 7.382 |

For coal costing \$42 per ton with a high heat value of 12,500 Btu/lb, the average fuel cost is \$1.68 per 10^6 Btu input.

C.5.2 Economic Analysis Parameters

a. Constants. The following factors will be treated as constants in the AFCS evaluations:

- HHV_{RDF} = 5,625 Btu/lb
- HHV_{coal} = 12,500 Btu/lb
- LF = 0.75 for full firing boilers
Note: No derating of boilers required
- T = 8,760 hr/yr
- C_c = \$1.68
- DF_{coal} = 8.873
- DF_N = 7.382

b. Variables. The following factors will be varied to test the effect on the AFCS evaluations:

- Boiler efficiency - from 70% to 74%
- RDF unit costs - from \$0/ton to \$30/ton

C.5.3 Annual Fuel Cost Savings

Table C-3 shows the AFCS factors for different cost and operating conditions.

Table C-3. Annual Fuel Cost Savings.

| RDF Price | | ANNUAL FUEL COST SAVINGS | | | | |
|--|-----------|--|-------------|-------------|-------------|-------------|
| | | Boiler(s) Rated Output Capacity - 10 ⁶ Btu/Hr | | | | |
| (\$/Ton) | (\$/MBtu) | 100 (\$000) | 150 (\$000) | 200 (\$000) | 300 (\$000) | 450 (\$000) |
| <u>74% Co-firing Boiler Efficiency - No Derating</u> | | | | | | |
| 0 | 0 | 723 | 1,085 | 1,447 | 2,170 | 3,255 |
| 5 | 0.444 | 526 | 789 | 1,052 | 1,577 | 2,366 |
| 10 | 0.889 | 328 | 492 | 655 | 983 | 1,475 |
| 15 | 1.333 | 130 | 195 | 260 | 390 | 585 |
| 20 | 1.788 | (68) | (102) | (136) | (204) | (306) |
| 25 | 2.222 | (266) | (398) | (531) | (797) | (1,195) |
| 30 | 2.667 | (464) | (695) | (927) | (1,391) | (2,086) |
| <u>72% Co-firing Boiler Efficiency - No Derating</u> | | | | | | |
| 0 | 0 | 782 | 1,172 | 1,563 | 2,345 | 3,517 |
| 5 | 0.444 | 579 | 868 | 1,157 | 1,736 | 2,603 |
| 10 | 0.889 | 375 | 562 | 750 | 1,125 | 1,687 |
| 15 | 1.333 | 172 | 258 | 344 | 516 | 773 |
| 20 | 1.778 | (32) | (48) | (63) | (95) | (143) |
| 25 | 2.222 | (235) | (352) | (470) | (705) | (1,057) |
| 30 | 2.667 | (438) | (658) | (877) | (1,315) | (1,973) |
| <u>70% Co-firing Boiler Efficiency - No Derating</u> | | | | | | |
| 0 | 0 | 847 | 1,271 | 1,695 | 2,542 | 3,814 |
| 5 | 0.444 | 639 | 958 | 1,277 | 1,916 | 2,873 |
| 10 | 0.889 | 429 | 644 | 858 | 1,287 | 1,931 |
| 15 | 1.333 | 220 | 330 | 440 | 661 | 991 |
| 20 | 1.778 | 11 | 16 | 21 | 32 | 49 |
| 25 | 2.222 | (198) | (297) | (396) | (594) | (891) |
| 30 | 2.667 | (407) | (611) | (815) | (1,222) | (1,834) |

C.5.4 Capital Investment Costs

C.5.4.1 Design Factors

A. General: The primary storage facilities shall be designed on the basis of table C-2 daily consumption data accelerated by 150% to cover weekend operations without deliveries, and irregularities in delivery, load demand, plant operations, etc. RDF is assumed to be delivered on the average 5 days per week, 52 weeks per year.

All other RDF systems including the conveyor systems, intermediate storage bins, prefeed mills, pneumatic delivery systems, boiler modifications and ash collection systems shall be based on operations at 100% of boiler capacity vice the 90% load factor used in developing table C-2.

B. RDF Storage System Design: The RDF storage system will consist of two Atlas bins, allowing one to be filled while one is being drawn-down. The total storage requirements for two 50 MBtu/hr boilers would equal:

$$S_R = W_R \times F_S = 66.67 \text{ tons/day} \times 2.5$$

$$= 166.68 \text{ tons/day/boiler} \times 2 \text{ boilers} = 333 \text{ tons/day}$$

where: S_R = RDF storage

F_S = storage factor = unity + 150% for delivery and production variances

Two 175-ton storage bins would be used for a double boiler operation.

Table C-4 provides a size and cost comparison for various storage units for different boiler plant operations, based on using a double bin operation. Usage of a single bin in lieu of twin or double bins would reduce costs by 30 to 35% but would remove the redundancy capability.

Table C-4. Capital Costs Summary (Atlas Storage Bins).

| Number of Boilers | Boiler Output (MBtu/hr) | Storage ¹ Requirements (Tons) | Storage Design (No. - Bin Size) | Cost of ² Installation (\$000) |
|-------------------|-------------------------|--|---------------------------------|---|
| 2 | 50 | 333 | 2-175 | 1,400 |
| 2 | 75 | 500 | 2-250 | 1,600 |
| 2 | 100 | 668 | 2-340 | 1,865 |
| 2 | 150 | 1000 | 2-500 | 2,530 |
| 3 | 150 | 1500 | 2-750 | 3,800 |

- Notes: 1. Storage requirements = 2.5 x normal daily use. System designed to cover weekend operations without RDF delivery.
 2. Installation costs include concrete slab and foundation.

C.5.4.2 Capital Investment Cost Estimates. Table C-5 shows the different capital investment costs estimated for each boiler system planned for retrofit based on vendors quotes obtained via a telephone survey. The vendors quotes also contain the current 1983 costs to install the systems including structural modifications and foundation supports.

C.5.5 O&MN Costs

Table C-6 reflects the increased or supplemental costs that may be experienced annually in the operation of the Navy boilers and RDF storage and delivery systems. Individual cost factors are contained in the case studies.

C.5.6 Annual O&M and Capital Investment Cost Factors

The basic economic model has already been outlined in section C.4.1;

i.e.:

$$\text{AFCS} \quad \frac{\text{NPV(I)}}{\text{DF}_N} + \frac{\text{NPV(I}_R)}{\text{DF}_N} + \Delta \text{ Ops} + \Delta \text{ Maint} - \Delta \text{ Solid Waste Removal} \\ + \Delta \text{ Other}$$

The projected AFCS are summarized for each boiler group in section

C.5.3.

The capital investment costs and supplemental O&M costs summarized in tables C-5 and C-6 can be redefined in terms of annual cost factors to be plotted against the AFCS factors to determine the breakeven point or net profit for each group of boilers.

The capital investment and O&M cost factors can be stated as follows:

- The annual charge to recover the original capital investment $(\text{NPV(I)}/\text{DF}_N)$ is equal to the Net Present Value of the capital investment, using 0.9025 as the discount factor for the 2 years during which construction is occurring, divided by the 20-year cumulative discount factor, 9.203 (year 22) - 1.821 (year 2) = 7.382.

Table C-5. Capital Investment Cost Summary
Navy Boiler Plant Modifications

| CAPITAL INVESTMENT COST CATEGORY | TOTAL RETROFITTED CAPACITY | | | | |
|-------------------------------------|--|--|---|---|---|
| | 100 MBtu/hr. (2-50 MBtu/hr. Boilers) | 150 MBtu/hr. (2-75 MBtu/hr. Boilers) | 200 MBtu/hr. (2-100 MBtu/hr. Boilers) | 300 MBtu/hr. (2-150 MBtu/hr. Boilers) | 450 MBtu/hr. (3-150 MBtu/hr. Boilers) |
| | (\$000) | (\$000) | (\$000) | (\$000) | (\$000) |
| 1. Primary Storage-Atlas Bins | \$1,400 | \$1,600 | \$1,865 | \$2,530 | \$3,800 |
| 2. Pneumatic Conveyor Sys. | 232 | 265 | 325 | 410 | 520 |
| 3. Boiler Modifications | 420 | 470 | 553 | 650 | 960 |
| 4. Soot Blower | 45 | 48 | 51 | 60 | 75 |
| 5. Process Control & Instru. | 80 | 85 | 94 | 110 | 130 |
| 6. Ash Handling Sys. | 110 | 122 | 136 | 160 | 185 |
| 7. Burner & Feed Mods | 130 | 150 | 170 | 200 | 280 |
| 8. Mech. & Elect. | 510 | 620 | 765 | 900 | 1350 |
| 9. Subtotal | 2,927 | 3,360 | 3,959 | 5,020 | 7,300 |
| 10. 10% Contingency | 293 | 336 | 396 | 502 | 730 |
| 11. Subtotal | 3,220 | 3,696 | 4,355 | 5,522 | 8,030 |
| 12. Engineering (8%) | 258 | 296 | 348 | 442 | 642 |
| 13. Total Costs | \$3,478 | \$3,992 | \$4,703 | \$5,964 | \$8,672 |

Note: Start up costs are included in the individual line item costs.

Table C-6. O & M Supplemental Costs

| O & M COST CATEGORY | TOTAL RETROFITTED CAPACITY | | | | |
|-------------------------|--|--|---|---|---|
| | 100 MBtu/hr. (2-50 MBtu/hr. Boilers) | 150 MBtu/hr. (2-75 MBtu/hr. Boilers) | 200 MBtu/hr. (2-100 MBtu/hr. Boilers) | 300 MBtu/hr. (2-150 MBtu/hr. Boilers) | 450 MBtu/hr. (3-150 MBtu/hr. Boilers) |
| | (\$000) | (\$000) | (\$000) | (\$000) | (\$000) |
| 1. <u>Operations</u> | | | | | |
| <u>Utility Transfer</u> | | | | | |
| Electrical | \$ 3 | \$ 4 | \$ 4 | \$ 5 | \$ 7 |
| 2. <u>Maintenance</u> | | | | | |
| Labor | 10 | 12 | 14 | 21 | 30 |
| Material | 8 | 10 | 11 | 15 | 22 |
| Contracts | 30 | 35 | 40 | 58 | 84 |
| 3. Subtotal | 51 | 61 | 69 | 99 | 143 |
| 4. Administration | 6 | 7 | 8 | 12 | 16 |
| 5. Total | \$ 57 | \$ 68 | \$ 77 | \$111 | \$159 |

- The annual charge to recover the capital investment to replace equipment $(NPV(I_R)/DF_N)$ is equal to zero in this analysis. An accelerated maintenance and repair program is used in lieu of equipment replacement.
- The change in operating cost (ΔOps) is equal to increases in the electricity, water, and ash disposal.
- The change in maintenance ($\Delta Maint$) is equal to the increase in maintenance labor and materials to maintain the RDF system and boiler.
- The solid waste consumed in producing RDF will predominately come from municipal waste due to the small volume generated by the Navy. It is assumed that the tipping fee costs will be equal to the rate for the alternative for disposal of municipal waste which will be equal to or greater than the cost of the Navy disposal method. Therefore, the savings in Navy solid waste removal (ΔSWR) is treated as zero in this analysis assuming that the cost to dispose of solid waste is the same whether the Navy uses landfill disposal or pays a solid waste processing plant to take the refuse.
- Administrative costs ($\Delta Other$) include labor and payroll benefits required to support the increased maintenance requirement.

Maintenance variances of (+80%) and (-20%), covering labor and materials, are used to provide a sensitivity test of operations to determine the impact of major repair or overhaul variances being experienced above or below the plan. No equipment replacement is planned.

A sample calculation to develop the annual applied cost factor is provided as follows:

- 100 MBtu/hr boiler plant (two 50 MBtu/hr boilers)

$$\begin{array}{rcl}
 NPV(I) & = & \$3,478,000 \times 0.9025 \\
 & = & \$3,138,895 \\
 \frac{NPV(I)}{DF} & = & \frac{\$3,138,895}{7.382} \qquad \qquad \qquad \$ 425,209 \\
 & N & \\
 \\
 NPV(I) & & \\
 \frac{R}{DF} & & 0 \\
 & N &
 \end{array}$$

| | |
|--|------------|
| Δ Ops + Δ Maint + Δ Other | 57,000 |
| Δ SWR | 0 |
| Estimated Annual Applied Cost | \$ 482,209 |

Applying the maintenance variances:

| | |
|------------------------------|------------|
| High Cost Estimate | \$ 527,809 |
| (\$482,209 + 0.8 x \$57,000) | |
| Probable Cost Estimate | 482,209 |
| Low Cost Estimate | 470,809 |
| (\$482,209 - 0.2 x \$57,000) | |

For the other boiler groups:

● 150 MBtu/hr boiler plant (two 75 MBtu/hr boilers)

| | |
|------------------------|-----------|
| High Cost Estimate | \$610,449 |
| Probable Cost Estimate | 556,049 |
| Low Cost Estimate | 542,449 |

● 200 MBtu/hr boiler plant (two 100 MBtu/hr boilers)

| | |
|------------------------|-----------|
| High Cost Estimate | \$713,574 |
| Probable Cost Estimate | 651,974 |
| Low Cost Estimate | 636,574 |

● 300 MBtu/hr boiler plant (two 150 MBtu/hr boilers)

| | |
|------------------------|-----------|
| High Cost Estimate | \$928,940 |
| Probable Cost Estimate | 840,140 |
| Low Cost Estimate | 817,940 |

● 450 MBtu/hr boiler plant (three 150 MBtu/hr boilers)

| | |
|------------------------|-------------|
| High Cost Estimate | \$1,346,411 |
| Probable Cost Estimate | 1,219,211 |
| Low Cost Estimate | 1,187,411 |

C.5.7 Break-even Point Analysis

Figures C-1 through C-5 provide cost curves for each boiler group comparing annual fuel cost savings for different boiler ratings and efficiencies, with RDF unit prices and O&M costs. The AFCS are extracted from table C-3. The capital recovery costs and O&M costs are derived in section C.5.6. The most probable values of the capital recovery and supplemental O&M costs were used to plot against the AFCS values.

The break-even point varied between \$0.656 per MBtu (\$7.60 per ton) for

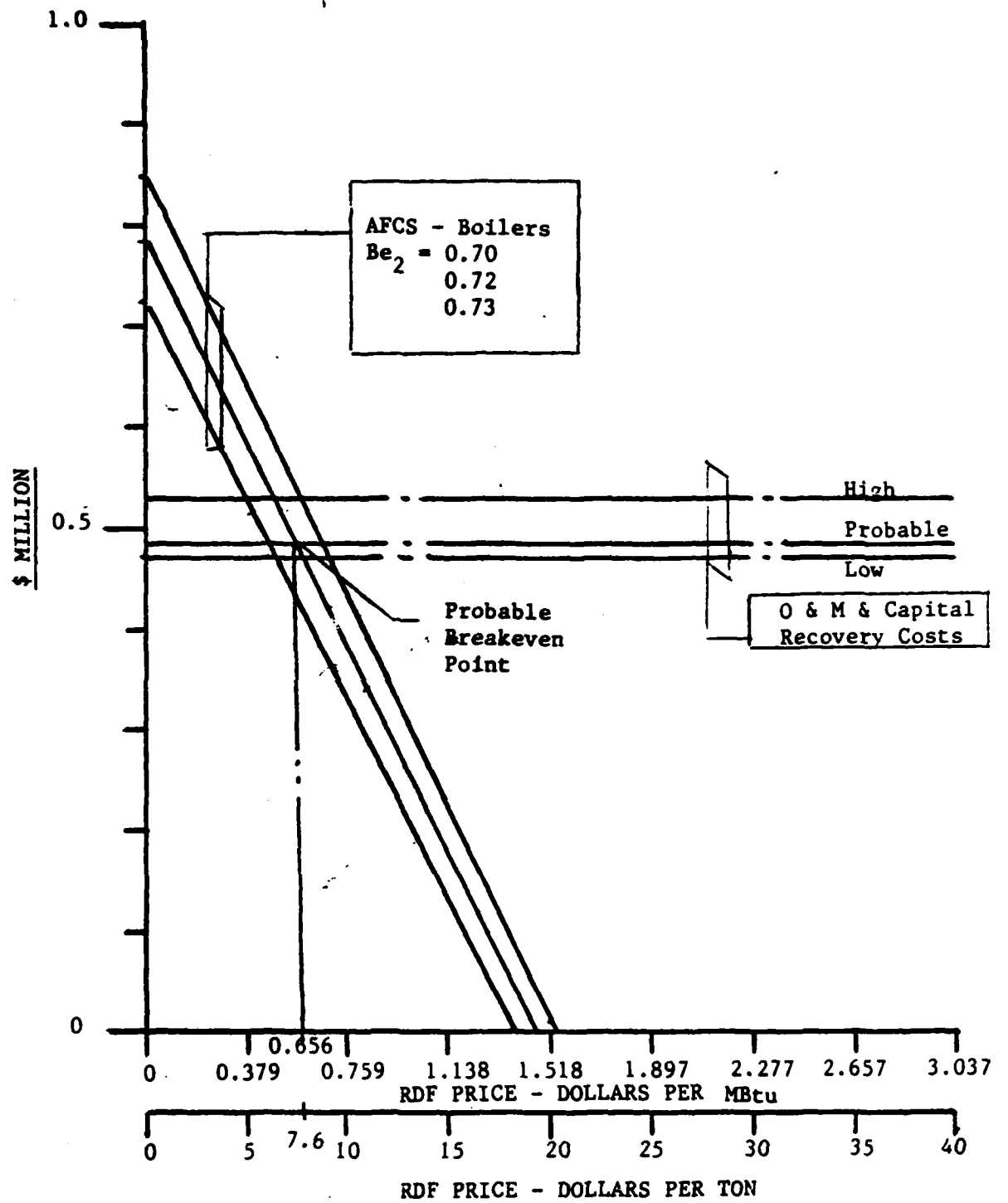

Figure C-1. Comparison of Annual Fuel Cost Savings to O&M, RDF, and Capital Recovering Cost for a Boiler Capacity of 100 MBtu/hr (2-50 MBtu/hr Boilers).

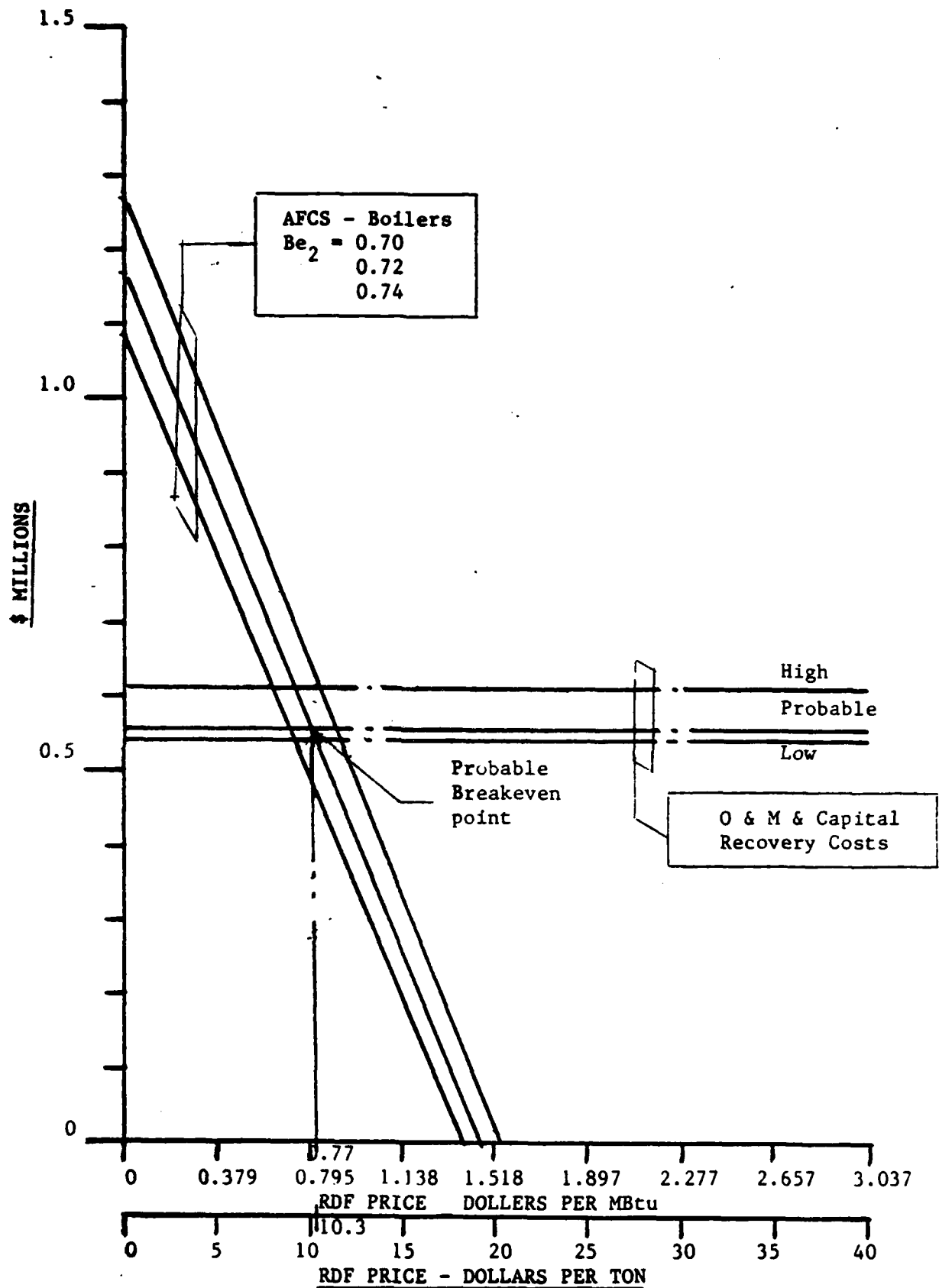

Figure C-2. Comparison of Annual Fuel Cost Savings to O&M & Capital Recovery Cost for a Boiler Capacity of 150 MBtu/hr (2-75 MBtu/hr Boilers).

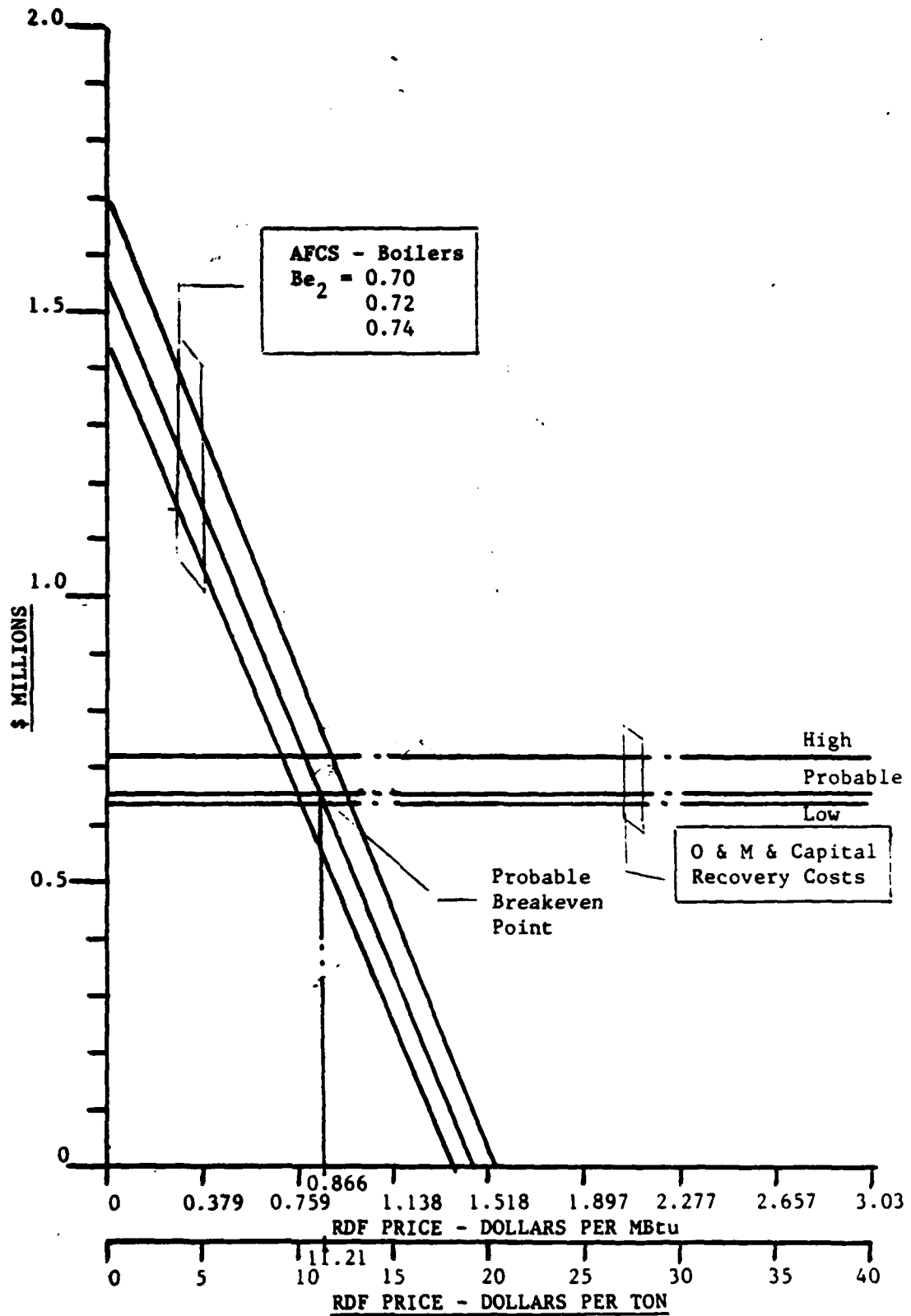

Figure C-3. Comparison of Annual Fuel Cost Savings to O&M, RDF, and Capital Recovery Cost for a Boiler Capacity of 200 MBtu/hr (2-100 MBtu/hr Boilers).

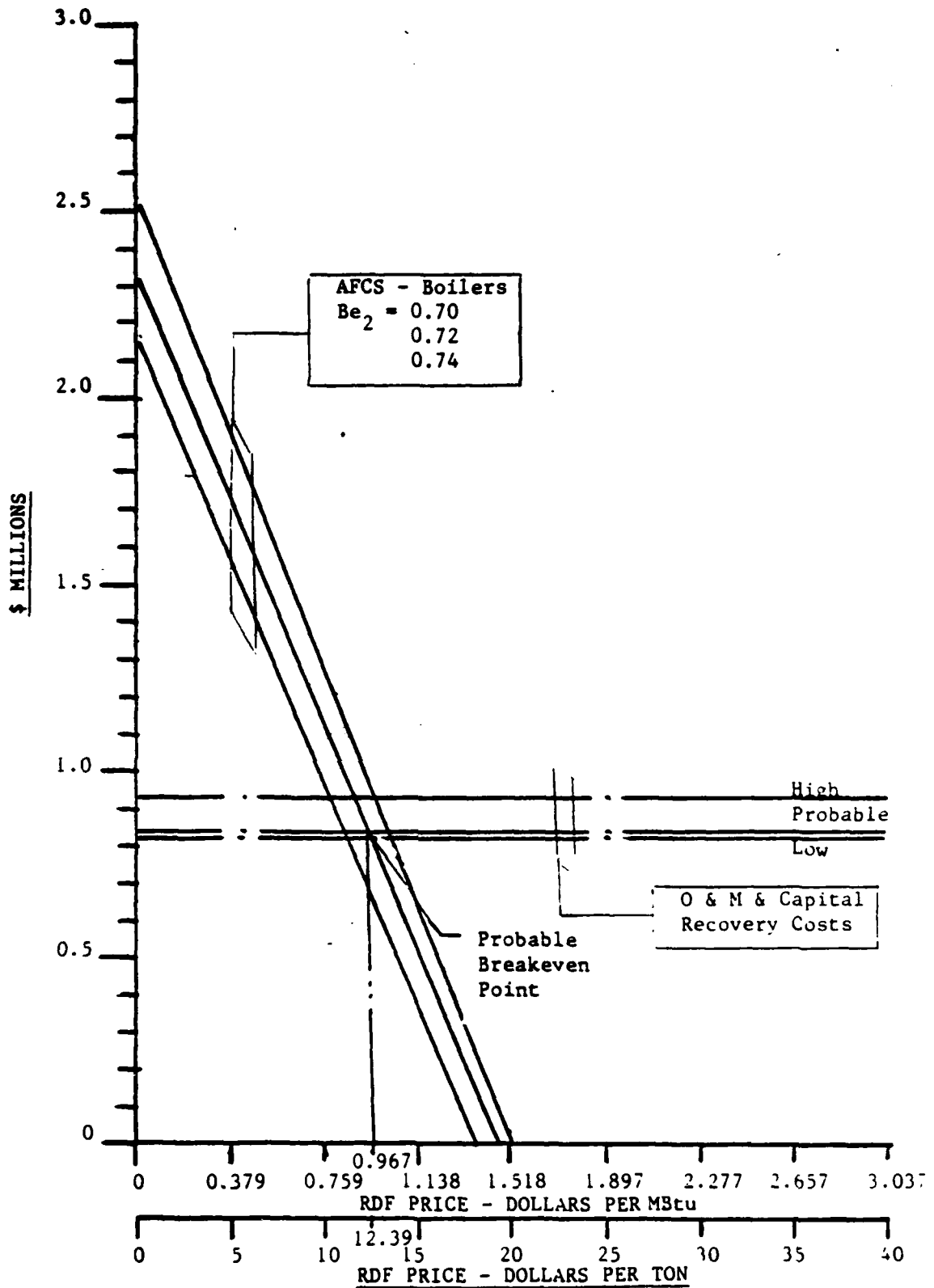

Figure C-4. Comparison of Annual Fuel Cost Savings to O&M, RDF, and Capital Recovery Cost for a Boilers Capacity of 300 MBtu/hr (2-150 MBtu/hr Boilers).

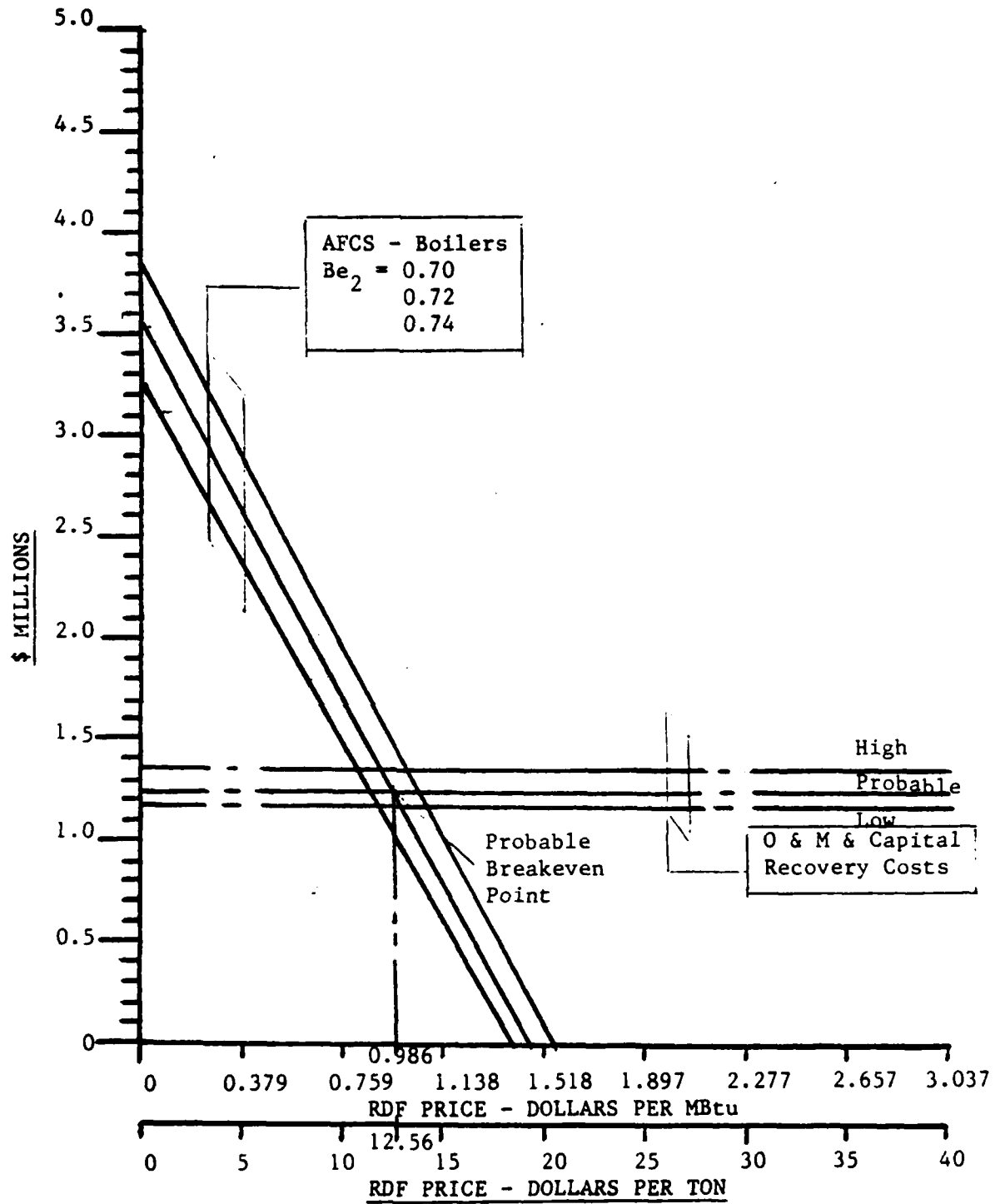

Figure C-5. Comparison of Annual Fuel Cost Savings to O&M, RDF, and Capital Recovery Cost for a Boiler Capacity of 450 MBtu/hr (3-150 MBtu/hr Boilers).

two 50 MBtu/hr boilers, to \$0.986 per MBtu (\$12.56 per ton) for three 150 MBtu/hr boilers.

C.5.8 Case Studies

Two case studies are provided in annex II to show the total parameters considered in evaluating the decision to fire coal or co-fire coal and RDF.

In case 1, an MSW plant sized for 35 tons per hour was selected to be used. A single-shift operation was planned. The cost to build the plant was \$8.3 million spread over a 2-year period. Discounting produces a net present cost of \$7.4 million. Converting the net present cost of \$7.4 million to an annual charge that would have to be applied to the operations of the MSW plant to recover the original capital cost produced an annual charge of \$1,003,000. Producing 61,000 tons of RDF-2 would cost \$1.3 million annually resulting in an average annual rate of RDF equal to \$22.54 per ton, or \$2.78 per 10^6 Btu produced as energy. The tipping fee used was \$15/ton.

In case 2, the MSW plant was again sized for 35 tons per hour per shift but with a double-shift operation. The cost to build the plant stayed the same, \$8.3 million with a net present cost of \$7.4 million. The annual capital investment recovery charge stayed the same \$1,003,000. Now producing 122,000 tons of RDF-2 and operating at 90% of boiler capacity, resulted in an annual cost ranging from \$854,000 (first 10 years) to \$1,179,000 (second 10 years), or \$7.00 to \$9.66 per ton. Again a tipping fee of \$15 per ton was used. If the decision was made to replace rather than repair RDF equipment at the end of 10 years, the unit cost would increase to \$8.39 per ton spread over the entire 20 years. In either case, the cost per 10^6 Btu of energy produced would drop below \$1.00 per 10^6 Btu with an HHV of RDF equal to 5,625 Btu/lb, compared to the going rate for coal of \$2.15 per 10^6 Btu (for coal at \$42 per ton), based on an HHV of coal equal to 12,500 Btu/lb.

The capital investment costs for the RDF storage, delivery, and combustion systems would amount to \$6.0 million spread over a 2-year period.

The Net Present Value Analysis produces a net savings of \$4.2 million assuming an accelerated maintenance and overhaul program, or a savings of \$2.1 million with the replacement of the RDF equipment. Both conditions assume the two dual-fired boilers operate on 50% RDF and 50% coal. If the RDF input is reduced to 25% of the energy demand, the Net Present Value Analysis produces a net loss of \$7.7 million. The assumption is that with 25% RDF consumption, the MSW Plant will shift to a single shift, 8 hour per day operation.

C.5.9 Savings-to-Investment Ratios and Payback Periods

Assuming a normalized set of conditions; i.e., each boiler is at full rating and is operating in a co-fired mode at 72% efficiency, 90% of capacity, continuously operating at 24 hours per day, 305 days per year; and RDF can be purchased at \$10 per ton; then a savings-to-investment ratio and discounted payback period could be developed for each group of boilers as follows:

$$\text{SIR} = \frac{\text{O\&M Savings per Year}}{\text{Capital Recovery Cost per Year}}$$

For two 50 MBtu/hr boilers or 100 MBtu/hr capacity:

$$\begin{aligned} \text{O\&M Savings per Year} &= \text{AFCS} - \Delta\text{O\&M} \\ &= \$375,000 - \$57,000 \\ &= \$318,000 \end{aligned}$$

$$\text{Capital Recovery Costs per Year} = \$425,209$$

Therefore:

$$\text{SIR} = \frac{\$318,000}{\$425,209} = 0.75$$

For an SIR of 0.75 and an economic life of 20 years, referring to the conversion table in the Economic Analysis Handbook, the discounted payback period would equal 20 years (plus).

For each of the five generic classes of boiler facilities:

| <u>Total Boiler Group Capacity (MBtu/hr.)</u> | <u>SIR</u> | <u>Discounted Payback Period</u> |
|---|------------|--|
| 100 | 0.75 | 20.0 years (plus) |
| 150 | 1.01 | 20.2 years |
| 200 | 1.17 | 13.8 years |
| 300 | 1.39 | 10.0 years |
| 450 | 1.44 | 9.3 years |

C.6 SITE SPECIFIC REVIEWS

Six naval installations have boilers that either currently fire or will fire coal, and are considered to be technically suitable to co-fire RDF and coal.

C.6.1 Navy Public Works Center, Norfolk, VA

The available assets to be considered for conversion include one Riley Stoker, 220 MBtu/hr boiler located in building P-1. The boiler was brought on line in 1983 and operates on pulverized coal. The total plant assets consist of 8 boilers having a gross capacity of 1021 MBtu/hr. The other seven boilers in the plant are all oil-fired, overaged boilers and, therefore, are not being considered for conversion.

The normal building P-1 annual operations are profiled as follows:

| | |
|--------------------------|-------------------|
| Gross production: | 3,600,000 MBtu/yr |
| High average (3 months): | 450,000 MBtu/mo |
| Mid average (5 months): | 290,000 MBtu/mo |
| Low average (4 months): | 200,000 MBtu/mo |

The one boiler being considered can provide 1,450,000 MBtu/year operating at 90% capacity, 24 hours per day, 305 days per year operating on pulverized coal and RDF-3. RDF-3 will be required in order to sustain full suspension burning. The net resultant O&M savings would be \$0.72 million per

year with an RDF-3 price of \$10 per ton. With a capital investment equal to approximately \$3.4 million:

- The savings-to-investment ratios would equal 1.40.
- The discount payback period would equal 9.8 years.

If RDF-3 costs \$15 per ton, the resultant O&M savings would equal \$0.34 million. With a capital investment of \$3.4 million:

- The savings-to-investment ratio would equal 0.66.
- The discount payback period would equal 20 years (plus).

C.6.2 Naval Amphibious Base, Little Creek, VA

The available assets to be considered for conversion include two Wickes, 100 MBtu/hr boilers located in the main boiler plant. A third Wickes 100 MBtu/hr boiler would function as a coal-fired backup boiler.

The normal station annual operations are profiled as follows:

| | |
|--------------------------|-----------------|
| Gross Production: | 740,000 MBtu/yr |
| High average (3 months): | 100,000 MBtu/mo |
| Mid average (4 months): | 60,000 MBtu/mo |
| Low average (5 months): | 40,000 MBtu/mo |

The two boilers being considered can satisfy the entire demand load of 740,000 MBtu/yr operating at 90% capacity 305 days per year, each. If the two boilers provided the total production for the base, the resultant O&M savings could equal \$0.33 million per year with an RDF cost of \$10 per ton. With a capital investment equal to approximately \$4.7 million:

- The savings-to-investment ratio would equal 0.60.
- The discount payback period would exceed 20 years.

C.6.3 Naval Ordnance Center, Indian Head, MD

Three Combustion Engineering, 189 MBtu/hr boilers are located within the main boiler plant, two of which could be candidates for conversion to co-fired

RDF and coal operation. The third boiler would function as a coal-fired backup boiler.

The normal station annual operations are profiled as follows:

| | |
|--------------------------|-------------------|
| Gross Production: | 1,090,000 MBtu/yr |
| High average (5 months): | 102,000 MBtu/mo |
| Mid average (4 months): | 85,000 MBtu/mo |
| Low average (3 months): | 80,000 MBtu/mo |

The two boilers being considered are assumed to be capable of satisfying the total demand load of 1,090,000 MBtu/year operating at 90% capacity 305 days per year each. If the boilers could support the total annual production requirement, the resultant O&M savings could equal \$0.47 million with an RDF cost of \$10 per ton. With a capital investment equal to approximately \$7 million:

- The savings-to-investment ratio would equal 0.57.
- The discount payback period would exceed 20 years.

C.6.4 Marine Corps Air Station, Cherry Point, NC

Two Keeler, 95 MBtu/hr boilers are located within the main boiler plant which technically could be candidates for conversion to co-fired RDF and coal operations. Three other overaged residual oil-fired boilers would be available for backup.

The normal station annual operations are profiled as follows:

| | |
|--------------------------|-----------------|
| Gross Production: | 906,000 MBtu/yr |
| High average (3 months): | 110,000 MBtu/mo |
| Mid average (4 months): | 90,000 MBtu/mo |
| Low average (5 months): | 51,000 MBtu/mo |

The two boilers being considered are assumed to be capable of providing 906,000 MBtu/yr, the total station demand load. If the 2 boilers could support the total annual production requirement, the resultant O&M savings could equal

\$0.42 million with an RDF cost of \$10 per ton. With a capital investment equal to approximately \$4.7 million:

- The savings-to-investment ratio would equal 0.76.
- The discount payback period would exceed 20 years.

C.6.5 Puget Sound Naval Shipyard, Bremerton, WA

The boiler plants at the Puget Sound Naval Shipyard are currently planned to be replaced by one plant with three 150 MBtu/hr dual-firing RDF and coal boilers. The boilers will be water wall design and will be capable of firing either RDF, coal or a mixture of RDF and coal. The plant is planned for completion in 1987.

The normal station annual operations are profiled as follows:

| | |
|--------------------------|-------------------|
| Gross Production: | 1,040,000 MBtu/yr |
| High average (3 months): | 125,000 MBtu/mo |
| Mid average (4 months): | 85,000 MBtu/mo |
| Low average (5 months): | 50,000 MBtu/mo |

Theoretically, two boilers could satisfy the station total demand load. If operating at 50% RDF and 50% coal on the two operating boilers, the resultant O&M savings could equal \$0.5 million with an RDF cost of \$10 per ton. With a capital investment equal to approximately \$6.0 million:

- The savings-to-investment ratio would equal 0.73.
- The discount payback period would exceed 20 years.

If the two boilers could be fired at 100% RDF, the resultant O&M savings could equal \$1.0 million with an RDF cost of \$10 per ton. With a capital investment equal to approximately \$9 million:

- The savings-to-investment ratio would equal 1.0.
- The discount payback period would equal 20 years.

Note: It is assumed that the boilers, while being designed to fire either RDF or coal, will not have the necessary RDF support equipment installed at the time of construction.

C.6.6 Bremerton Sub Base, Bangor, WA

The boiler plant at the Bremerton Sub Base consists of two Keeler, 60 MBtu/hr boilers. Technically one boiler could be converted to co-fire RDF and coal; the second boiler would be used as a dedicated coal-fired backup boiler.

The normal station annual operations are profiled as follows:

| | |
|--------------------------|-----------------|
| Gross Production: | 220,000 MBtu/yr |
| High average (3 months): | 23,500 MBtu/mo |
| Mid average (4 months): | 18,500 MBtu/mo |
| Low average (5 months): | 13,000 MBtu/mo |

Theoretically, the one 60 MBtu/hr boiler could provide 194,000 MBtu/yr. The resultant O&M savings could equal \$0.08 million per year with an RDF cost of \$10 per ton. With a capital investment equal to approximately \$2.1 million:

- The savings-to-investment ratio would equal 0.33.
- The discount payback period would exceed 20 years.

ANNEX I TO APPENDIX C

MSW PROCESSING PLANT CAPITAL INVESTMENT REQUIREMENTS

1. GENERAL

A basic design is provided for the MSW processing plant using the mass balance data shown in figure A-1 and basing the capacities of major equipment on meeting RDF-2 demand requirements for a single 150 MBtu/hr boiler, operating 24 hours per day at 100% capacity for 305 days per year, consuming 50% RDF and 50% coal. The decision to limit the RDF/coal mix to a 50/50 split in reference to energy output, was made based upon operating experiences with retrofitted boilers and the problems associated with attempts to fire in excess of 50% RDF at that facility. The overall plant size was designed based upon a single shift, 8 hour per day, 5 day per week operation. The opportunity was included to run a second shift 8 hours per day, 5 days per week, and/or intermittent shift operations to expand plant output. A typical MSW processing plant layout is shown in figure C1-1. With a stoker coal-fired boiler, grating facilities are provided that are adequate for supporting the firing of RDF-2; therefore, the economics of considering RDF-3 have been excluded from this analysis. RDF-3 would become an economical consideration only when combined in a pulverized coal firing facility, requiring higher, more costly refinement.

2. MSW PROCESSING PLANT DESIGN

A stream flow for a typical selection of 100 lb of municipal solid waste is shown in table C1-1. From the 100 lb processed, 4.1 lb will be lost in tipping floor waste; of the remaining 95.9 lb that will be fed to the primary trommel, 39.49 lb will fall through to the air classifier and 56.41 lb will be fed to the shredder. As a result:

- Air classifier light fraction (75% of feed) will equal $0.75 \times 39.49 = 29.61$ lb.

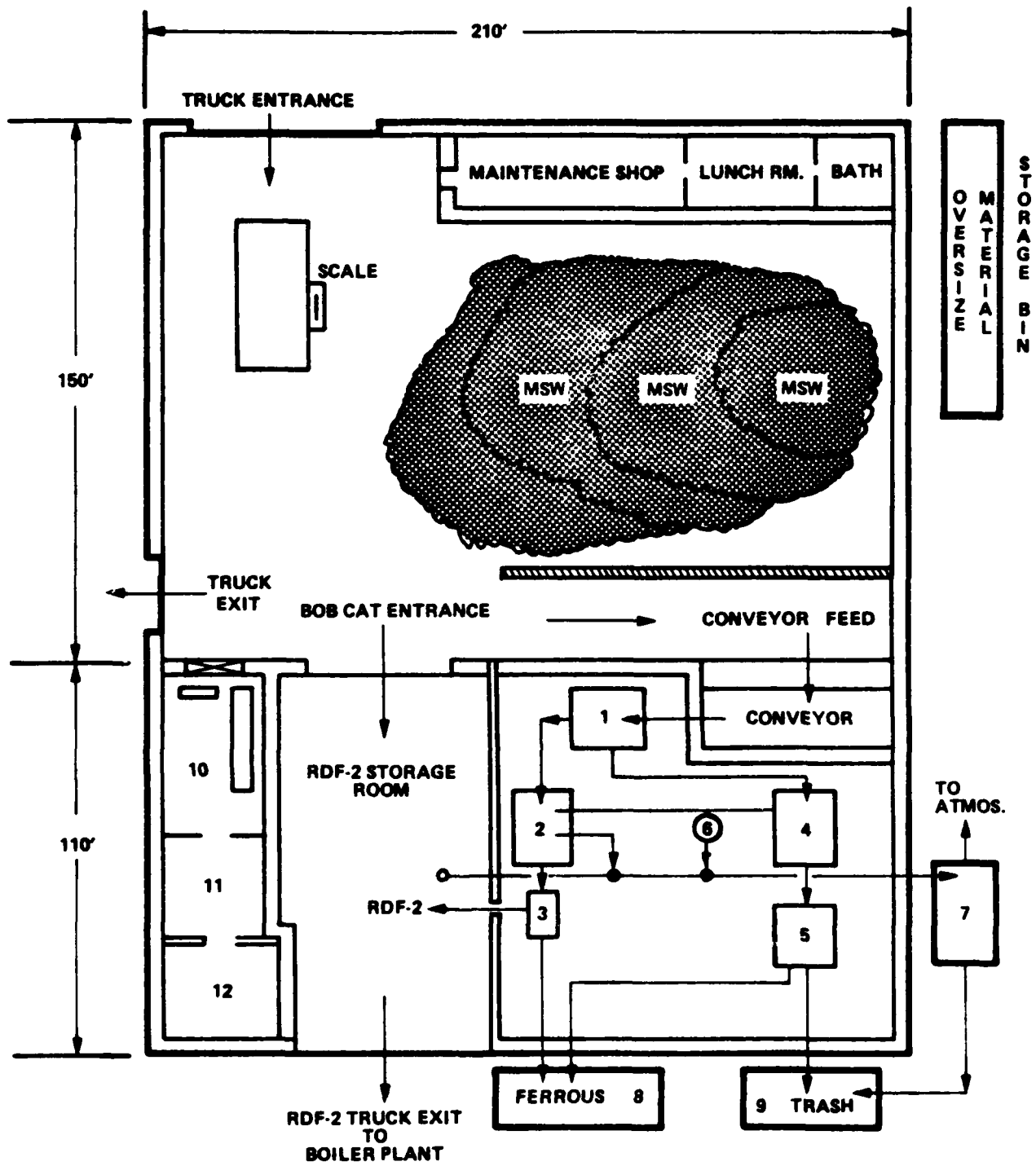

- LEGEND**
- | | |
|-----------------------|--------------------------|
| 1. TROMMEL | 7. BAG HOUSE |
| 2. SHREDDER | 8. Fe BIN |
| 3. MAGNETIC SEPARATOR | 9. TRASH BIN |
| 4. AIR CLASSIFIER | 10. INSTRUMENTATION ROOM |
| 5. MAGNETIC SEPARATOR | 11. OFFICE |
| 6. CYCLONE & STORAGE | 12. CONFERENCE ROOM |

Figure. C1-1. Proposed Plant Layout

Table C1-1. Analysis of Municipal Solid Waste Flow through a Processing Plant.

| Assumed MSW Category | As-Received MSW Characteristics (lb) | Tipping Floor Waste (lb) | Feed to Primary Trommel (lb) | Trommel Undersize as Feed to Air Classifier (lb) | Trommel Oversize As Feed to Shredder (lb) |
|----------------------|--------------------------------------|--------------------------|------------------------------|--|---|
| Corrugated Box | 4.29 | | 4.29 | 0.70 | 3.59 |
| Newspaper | 14.88 | | 14.88 | 3.20 | 11.68 |
| Magazine & Boxes | 4.38 | | 4.38 | 0.90 | 3.48 |
| Whse Paper | <u>28.95</u> | | <u>28.95</u> | <u>6.40</u> | <u>22.55</u> |
| Total Paper | <u>52.50</u> | | <u>52.50</u> | <u>11.20</u> | <u>41.30</u> |
| Plastics | 3.20 | | 2.90 | 1.80 | 1.10 |
| Textile | 0.70 | | 0.60 | 0.40 | 0.20 |
| Wood | 0.80 | | 0.60 | 0.30 | 0.30 |
| Yard Waste | 4.90 | 4.1 | 4.20 | 1.20 | 3.00 |
| Food Waste | 18.10 | | 17.60 | 10.30 | 7.30 |
| Rubber & Leather | <u>0.60</u> | | <u>0.50</u> | <u>0.30</u> | <u>0.20</u> |
| Total Com-bustibles | <u>80.80</u> | | <u>78.90</u> | <u>25.50</u> | <u>53.40</u> |
| Ferrous Metal | 6.00 | | 5.50 | 4.28 | 1.22 |
| Aluminum | 1.00 | | 0.90 | 0.69 | 0.21 |
| Nonferrous | 0.50 | | 0.40 | 0.07 | 0.33 |
| Glass & Ceramics | 10.70 | | 9.70 | 8.50 | 1.20 |
| Fines & Misc | <u>1.00</u> | | <u>0.50</u> | <u>0.45</u> | <u>0.05</u> |
| Total Inerts | <u>19.20</u> | | <u>17.00</u> | <u>13.99</u> | <u>3.01</u> |
| Stream Total | 100.00 | 4.1 | 95.9 | 39.49 | 56.41 |

- Air classifier heavy fraction (25% of feed) will equal $0.25 \times 39.49 = 9.88$ lb
- Loss of particulates in cyclone will equal (assume) 0.61 lb.
- Light fraction recycled to shredder will equal $29.61 - 0.61 = 29$ lb.
- Total feed to shredder = Trommel oversize + air classifier light fractions = $56.41 + 29 = 85.41$ lb.
- Primary magnetic separator feed will equal air classifier heavy fraction = 9.88 lb.
- Ferrous stream = 4.00 lb
 Other Nonferrous = 0.01 lb
 Organics = 0.24 lb
 Total Ferrous Stream = 4.25 lb
- Total nonmagnetic stream = $9.88 - 4.25 = 5.63$ lb. to landfill and dump.

From the mass balance of the MSW processing stream in figure A-1, 100 lb of municipal solid waste will produce 83.98 lb of RDF and 4.61 lb of recoverable and marketable ferrous products ($4.25 + 0.36$ lb).

A 150×10^6 Btu/hr stoker coal-fired boiler output, when retrofitted to burn 50% RDF 2, will have a thermal efficiency of 72%. Assuming a high heat value (HHV) of RDF-2 equal to 5,625 Btu/lb, and an average demand factor equal to 90% of boiler capacity, will result in consumption of 8.33 tons of the RDF per hour of operation or 200 tons per day; i.e.:

$$\text{RDF (@ 50\%)} = \frac{150 \times 10^6 \text{ Btu/hr}}{0.72 \times 5,625 \text{ Btu/lb} \times 2000 \text{ lb/ton}} \times 0.5 \times 0.9 = 8.33 \text{ tons}$$

If a mix of 25/75 were maintained, the RDF requirement would be reduced to 4.625 TPH or 111 tons per day. Wherein 50% RDF is technically feasible and economically attractive, the main effort in this analysis will be directed toward a 50% RDF, 50% coal mix.

The basic concept of operation for running the MSW Processing Plant will include:

- a. RDF and coal each providing 50% of the boiler energy output for the two boilers retrofitted in each case.
- b. The MSW Processing Plant will be designed to produce 235 tons of RDF per day, 260 days per year operating single shift, 8 hours per day, 5 days per week. A second shift could be used to produce an additional 235 tons per day.
- c. Maintenance work will be done in the second and/or third shift operations.
- d. No redundancy in process train will be made. In case of nonavailability of RDF, the boiler will be operated with 100% coal.
- e. In normal operations of 50% RDF co-firing with coal, the weight rate of RDF feed into the boiler will be constant and the coal feed rate will vary according to the variation of RDF heating value.

3. MSW PROCESSING PLANT EQUIPMENT DESIGN

Using the design criterion of a 235 TPH, 260 days per year, single-shift operation, equipment sizes were selected for installation in the MSW Processing Plant.

Assuming boiler operations of 305 days per year x 200 tons per day average, the total RDF-2 demand annually will equal 61,000 tons. The MSW Processing Plant capacity will equal 61,000 tons (260 days x 8 hours per day x 0.8398 MSW conversion factor) or 35 TPH. The major equipment capacities were calculated on the basis of the mass balance diagram data in figure A-1. Table C1-2 shows the design unit capacities for each piece of major equipment to be installed in the processing plant.

4. MSW PROCESSING PLANT CAPITAL INVESTMENT PROGRAM

Based upon the concept of producing 35 TPH, 8 hours per day, 260 days per year, MSW processing equipment totalling \$3.6 million will be required to provide a continuous process operation. Table C1-3 provides a breakdown of the specific equipment requirements. Vendor quotations were obtained on major pieces of equipment. Electrical and mechanical connection costs for the equipment were included in the unit prices along with a 3% markup for transportation.

Table C1-2. Capacity Requirements of MSW Processing Plant Equipment.

| Equipment | Capacity Calculated Value | Design Unit Capacity |
|------------------------------|--------------------------------|----------------------|
| Trommel Screen | $35 \times 0.959 = 33.5$ TPH | 35 TPH |
| Air Classifier | $35 \times 0.3949 = 13$ TPH | 15 TPH |
| Primary Magnetic Separator | $35 \times 0.0988 = 3.46$ TPH | 5 TPH |
| Shredder | $35 \times 0.8541 = 29.89$ TPH | 35 TPH |
| Secondary Magnetic Separator | $35 \times 0.8536 = 28.37$ TPH | 30 TPH |
| Atlas Storage Bin | 500 Tons | 500 Tons |
| Baghouse | 5000 SCFM | 5000 SCFM |

Table C1-3. MSW Processing Plant Capital Investment Cost for Equipment.

(35 TPH Operation)

| Major Equipment | Source (Vendor) | Purchase Cost (\$000) |
|--|--|-----------------------|
| ● Trommel Screen - Complete with drive and support structure; 9' dia x 28' long, 4-1/2" dia hole plate | Triple/S Dynamics Dallas, TX (214)821-9143 | \$ 215 |
| ● Air Classifier, complete with updraft fan, baffles and structure, and cyclone system | SAME | 203 |

Table C1-3. MSW Processing Plant Capital Investment Cost
for Equipment (Continued).

(35 TPH Operation)

| Major Equipment | Source (Vendor) | Purchase Cost (\$000) |
|---|---|--------------------------|
| ● Magnetic Separator (Primary) Model SQ-P, Drum Type 36" dia x 48" wide drum, permanent magnet, 1-1/2 HP drive and box frame | Eriez Magnetic Erie, PA (814)833-9881 | 36 |
| ● Primary Shredder (Model 72-50) | Saturn Shredder | 365 |
| ● Accessories | Saturn Shredder | 45 |
| ● Magnetic Separator (Secondary) | Eriez Magnetic | 38 |
| ● Weight Scale (auto record, card reader) | Toledo Scales | 200 |
| ● Ferrous collection bin | Shop - FAB | 30 |
| ● Air Classifier lights collection box with live-bottom retrieval | Same | 95 |
| ● Conveyor system, feed to trommel, trommel to A/C, trommel to shredder, shredder to magnetic separator, A/C heavies to magnetic separator and others | Rexnord | 650 |
| ● Baghouse for plant operation dust cleaning - 5000 SCFM Pulse-Jet | | 400 |
| ● Front End Loader (2 each) | | 60 |
| ● Power Hoist and Transfer Equip | | 45 |
| ● Electric Substation | | 85 |
| ● Motor Starters and Disconnect Switches | | 145 |
| ● Trucks to haul to landfill (3 each) | | 70 |
| ● Computers and Instrumentation | | <u>160</u> |
| ● Total Estimate - Equipment | | \$2,842 |
| ● Contingency (10%) | | 284 |

Table C1-3. MSW Processing Plant Capital Investment Cost
for Equipment (Continued).

(35 TPH Operation)

| Major Equipment | Source (Vendor) | Purchase Cost (\$000) |
|--------------------------------------|--------------------|--------------------------|
| • Subtotal | | 3,126 |
| • Engineering (16%) | | 500 |
| Total Capital Investment - Equipment | | \$3,626 |

The facilities cost to house the MSW Processing Plant equipment will exceed \$4.3 million as outlined in table C1-4. Within the concept of this report, the plant is to be installed on available Navy property; therefore, land acquisition cost has been excluded.

Table C1-4. MSW Processing Plant Capital Investment Cost for Facilities.

| Facility Element | Construction Cost (\$000) | |
|--|------------------------------|---------|
| • Land | \$ 0 | |
| • Site development | 150 | |
| • Building structure including masonry | 1,800 | |
| • Foundation - excavation, concrete, and reinforcement | 550 | |
| • Utilities, fencing, roadways, and lighting | 750 | |
| • Heating, air conditioning, and ventilation | 100 | |
| • Office equipment, mechanics tools, locker facilities | 50 | |
| • Total estimate - Facilities | \$3,400 | |
| • Contingency (10%) | 340 | |
| • Subtotal | 3,740 | |
| • Engineering (16%) | 598 | |
| Total Capital Investment - Facilities | | \$4,338 |

An additional \$330,000 will be added for startup costs covering repairs and modifications, operator training, property taxes, insurance during construction, and materials consumed during startup.

Contingencies of 10% have been included in both equipment and facilities

estimates. The engineering costs have been set at 16% consistent with commercial practices.

The costs of capital for this report will be taken as 10%. Capital investment and discounting practices will be treated as outlined in NAVFAC P-442, Economic Analysis Handbook. The useful life of the MSW Processing Plant will be treated as follows:

- For case 1 involving a single-shift operation, 8 hours per day, 260 days per year, a life expectancy of the equipment will be treated as 20 years and the facilities as 25 years. It is anticipated that with an accelerated maintenance program during the second 10 years, the equipment will last the entire 20-year period.
- For case 2 involving a double-shift operation, 16 hours per day, 260 days per year, a life expectancy of the equipment will be treated as both 10 years and 20 years for cost analysis purposes. For a 10-year life, the equipment will be replaced. For a 20-year life an accelerated repair and overhaul program will be specified. The facilities will continue to be treated as 25 years.

The total capital investment is equal to \$8,294,000 including plant, equipment and startup costs.

ANNEX II TO APPENDIX C
CASE STUDIES OF ECONOMIC ANALYSES
OF DUAL-FIRED RDF/COAL BOILER FACILITIES

1. CASE NUMBER 1

1.1 Case 1 - Concept of Operations

Assume that the gross plant production is 1,314,000 MBtu/year and the plant is equipped with three 100 MBtu/hr boilers. Plant loads would vary between 90 MBtu per hour and 190 MBtu per hour. Only boilers 1 and 2 would be retrofitted to fire RDF. Each boiler would be fired an average of 305 days per year. Boilers 1 and 2 would average 67.5 MBtu per hour or 68% of rated load continuously for 305 days to consume 61,000 tons per year. Boiler 3 would be used to support seasonal loads. Supporting this concept of operations, the following boiler operations would occur:

| | <u>Boiler #1 (Retrofitted)</u> | <u>Boiler #2 (Retrofitted)</u> | <u>Boiler #3</u> |
|---|------------------------------------|------------------------------------|------------------|
| Gross Output (MBtu/yr) | 494,100 | 494,100 | 325,800 |
| RDF Fuel Output @ 50% of Total (MBtu/yr) | 247,050 | 247,050 | NA |
| RDF Input @ 72% Eff. (MBtu/yr) | 343,125 | 343,125 | NA |
| Tons of RDF | 30,500 | 30,500 | NA |
| <u>Btu</u> 5625 x 2000 | | | |
| MSW Input | 36,318 | 36,318 | NA |
| <u>RDF</u> 0.8398 | | | |
| Total RDF required per year | 61,000 Tons | | |
| Total MSW processed | 72,636 Tons | | |

$$\text{Plant capacity} = \frac{72,636 \text{ tons}}{8 \text{ hrs/day} \times 260 \text{ days/yr}} = 35 \text{ tons/hr}$$

1.2 Case 1 - Estimate of MSW Plant Capital Investment Costs

| | <u>First Year</u> | <u>Second Year</u> |
|------------------------------|--------------------|--------------------|
| Process Plant Equipment | \$ 0 | \$2,842,000 |
| Support Facility | 1,561,000 | 1,839,000 |
| Subtotal | <u>1,561,000</u> | <u>4,681,000</u> |
| Contingency (10%) | 156,100 | 468,100 |
| Subtotal | <u>1,717,100</u> | <u>5,149,100</u> |
| Engineering Costs | 700,000 | 398,592 |
| Subtotal - Installation | <u>2,417,100</u> | <u>5,547,692</u> |
| Organization and Startup | 30,000 | 300,000 |
| Subtotal | <u>2,447,100</u> | <u>5,847,692</u> |
| Discount Factor | x 0.954 | x 0.867 |
| Net Present Value (NPV) | <u>\$2,334,000</u> | <u>\$5,069,949</u> |
| | | <u>2,334,000</u> |
| Total NPV Capital Investment | | <u>\$7,403,949</u> |

Annual Capital Investment Recovery Charge \$1,002,973

The distribution of the total NPV over the
20-year production period to recover costs:

Discount Factor = 22 Yr Factor - 2 Yr Factor
or 9.203 - 1.821 = 7.382

Annual Charge = $\frac{\text{Total NPV}}{\text{Discount Factor}} = \frac{\$7,403,949}{7.382}$

= \$1,002,973 = \$1,003,000

1.3 Case 1 - Annual MSW Facility Production Cost

| | <u>Operating Cost</u> | |
|--------------------------------|-----------------------|------------------------|
| | <u>First 10 Years</u> | <u>Second 10 Years</u> |
| <u>Operations Costs</u> | | |
| Labor ¹ | \$ 192,000 | \$ 192,000 |
| Fuel | 15,000 | 15,000 |
| Material | 25,000 | 25,000 |
| <u>Maintenance Costs</u> | | |
| Labor ² | 64,000 | 74,000 |
| Material ³ | 160,000 | 180,000 |
| Contracts ⁴ | 0 | 50,000 |
| <u>Utilities</u> | | |
| Electricity ⁵ | 77,000 | 77,000 |
| Water ⁶ | 50,000 | 50,000 |
| Landfill disposal ⁷ | 30,000 | 30,000 |
| Subtotal (direct) | <u>613,000</u> | <u>693,000</u> |

Overhead

| | | |
|--|--------------------|--------------------|
| Supervision ⁸ | 29,000 | 29,000 |
| Administrative ⁹ | 57,000 | 59,000 |
| Payroll Acceleration ¹⁰ | 106,000 | 110,000 |
| Insurance ¹¹ | 40,000 | 40,000 |
| Taxes ¹² | 160,000 | 160,000 |
| G&A ¹³ | 160,000 | 160,000 |
| Capital Invest. Charge | <u>1,003,000</u> | <u>1,003,000</u> |
| Subtotal (Overhead) | <u>1,555,000</u> | <u>1,561,000</u> |
| Total (Direct and Overhead) | 2,168,000 | 2,254,000 |
| <u>Less Credits</u> | | |
| Tipping Fee @ \$15/Ton MSW [72,636 Tons x \$15] | (1,090,000) | (1,090,000) |
| Ferrous Metals @ \$15/Ton [72,636 Tons x 0.0461 x \$15] | (50,000) | (50,000) |
| Subtotal (Credits) | (1,140,000) | (1,140,000) |
| Net Production Costs | 1,028,000 | 1,114,000 |
| Profit (16% of Gross Cost) ¹⁴ | 347,000 | 361,000 |
| Total Annual Production Cost | <u>\$1,375,000</u> | <u>\$1,475,000</u> |
| Cost per Ton of RDF 2 | \$22.54 | \$24.18 |

Notes:

- Plant operating labor based upon 2080 man-hour (MH)/year x \$10.26/MH direct cost for 9 people

Process Technician 3 people
Tipping Floor Operations . . . 3 people
Control Room 1 person
Truck Driver 2 people

- Maintenance labor based upon 3 people 2080 MH/yr x \$10.26/MH direct for first 10 years and 3.5 people for the second 10 years.
- Maintenance materials and supplies based upon 2% of capital investment cost first 10 years and 2.25% during the second 10 years.
- Maintenance overhaul contracts required during second 10 years due to advanced age and condition of equipment.
- Electricity based upon 1,413,280 kWh @ 5.5¢ per kWh covering following equipment:

| | | |
|----------------------|---------------|-----------------|
| Shredder | 400 HP | |
| Trommel | 5 HP | |
| Mag. Separator | 11 HP | |
| Air Classifier | 15 HP | |
| Conveyors | 50 HP | |
| Fans and Blowers | 15 HP | |
| Miscellaneous | 4 HP | |
| | <u>500 HP</u> | = 373 kW |
| Indirect Electricity | | = <u>172 kW</u> |
| | | 545 kW (Max) |

6. Water @ \$0.80/1000 gals.
7. Plant process discard; i.e., nonferrous materials and bulky refuse @ \$2500 per month.
8. Plant Supervision @ 15% of plant operating labor.
9. Administrative labor @ 20% of total direct and supervisor labor.
10. Payroll burden @ 31% of total labor.
11. General insurance fee @ 0.5% of capital investment.
12. Taxes computed @ 2% of capital investment.
13. G&A expenses including accounting, purchasing, legal services, office services, communications etc. based on 2% of capital investment.
14. Profit is estimated to be 16% of total direct and overhead costs before credits are deducted.

1.4 Case 1 - Capital Investment Costs for RDF Storage and Conveyor Sub-
systems and Boiler Retrofit

RDF Storage and Conveyor System

| | |
|---------------------------------|----------------|
| Atlas Storage Bin (500 Ton Cap) | \$840,000 |
| Storage Support Structure | 425,000 |
| Pneumatic Conveyor Vault | 30,000 |
| Pneumatic Conveyor | <u>195,000</u> |
| Subtotal | \$1,490,000 |

Boiler Retrofit

| | |
|--------------------------------|----------------|
| Boiler modifications | 553,000 |
| Soot Blower System Mods | 51,000 |
| Process Control & Instrument | 94,000 |
| Ash Handling System Mods | 85,000 |
| Structural and Support Systems | 51,000 |
| Coal Burner and Feed Mods | 170,000 |
| Mechanical and Electrical Mods | <u>765,000</u> |
| Subtotal | \$1,769,000 |

| | |
|-------------------------------------|--------------------|
| <u>Subtotal Specific Work</u> | <u>\$3,259,000</u> |
| <u>Contingency (10%)</u> | <u>326,000</u> |
| <u>Subtotal Plant Modifications</u> | <u>3,585,000</u> |
| <u>Engineering Cost (8%)</u> | <u>287,000</u> |
| <u>Total Capital Investment</u> | <u>\$3,872,000</u> |

Breakdown of Capital Investment Expenditures

| | <u>First Year</u> | <u>Second Year</u> |
|----------------------------------|--------------------|--------------------|
| RDF Storage and Conveyor Systems | \$ 400,000 | \$1,090,000 |
| Boiler Retrofit | 750,000 | 1,019,000 |
| Subtotal | <u>1,150,000</u> | <u>2,109,000</u> |
| Contingency (10%) | 115,000 | 211,000 |
| Subtotal | <u>1,265,000</u> | <u>2,320,000</u> |
| Engineering Costs | 245,000 | 42,000 |
| Total Capital Investment | <u>\$1,510,000</u> | <u>\$2,362,000</u> |

1.5 Case 1 - Net Present Value Analysis (50% RDF)

Net present cost of plant operations using 50% RDF and 50% coal in each of two boilers and 100% coal in the third boiler for 20 years starting with year (+3) and ending with year (+22):

| <u>Cost Element</u> | <u>Unadjusted Cost</u> | <u>Discount Factor</u> | <u>Net Present Cost</u> |
|-------------------------------|----------------------------|----------------------------|-----------------------------|
| Capital Investment | \$1,510,000 | 0.954 | \$1,440,540 |
| | 2,362,000 | 0.867 | 2,047,790 |
| O&M Costs | | | |
| Operations Costs | | | |
| Labor | 717,535 | 7.382 | 5,296,843 |
| Fuel (Coal) | 1,850,394 | 8.873 | 16,418,545 |
| Fuel (RDF - First 10 Yr) | 1,375,000 | 5.328 | 7,326,000 |
| (RDF - Second 10 Yr) | 1,475,000 | 2.054 | 3,030,000 |
| Materials | 52,000 | 7.382 | 383,864 |
| Contracts | 24,500 | 7.382 | 180,859 |
| Maintenance Costs | | | |
| Labor (First 10 Yr) | 214,200 | 5.328 | 1,141,258 |
| (Second 10 Yr) | 224,200 | 2.054 | 460,507 |
| Material (First 10 Yr) | 34,000 | 5.328 | 181,152 |
| (Second 10 Yr) | 49,000 | 2.054 | 100,646 |
| Contracts (First 10 Yr) | 254,500 | 5.328 | 1,355,976 |
| (Second 10 Yr) | 294,500 | 2.054 | 604,903 |
| Overhead | | | |
| General Plant Expense | 71,000 | 7.382 | 524,122 |
| Utility Transfer | | | |
| Electricity | 200,000 | 7.382 | 1,476,400 |
| Potable Water | 88,000 | 7.382 | 649,616 |
| Net Present Cost (20 Yr Ops). | | | <u>\$42,619,000</u> |

1.6 Case 1 - Net Present Value Analysis (100% Coal)

Net present cost of plant operations using 100% coal for 20 years starting with year (+3) and ending with year (+22):

| <u>Cost Element</u> | <u>Cost Factor</u> | <u>Discount Factor</u> | <u>Net Present Cost</u> |
|-----------------------------------|--------------------|------------------------|-------------------------|
| Capital Investment | \$ 0 | 1.000 | \$ 0 |
| O&M Costs | | | |
| Operations Costs | | | |
| Labor | 717,535 | 7.382 | 5,296,843 |
| Fuel (Coal) | 2,830,170 | 8.873 | 25,112,098 |
| Materials | 52,000 | 7.382 | 383,864 |
| Contracts | 24,500 | 7.382 | 180,859 |
| Maintenance Costs | | | |
| Labor | 194,200 | 7.382 | 1,433,584 |
| Materials | 24,000 | 7.382 | 177,168 |
| Contracts | 240,000 | 7.382 | 1,771,680 |
| Overhead General | | | |
| General Plant Expense | 71,000 | 7.382 | 524,122 |
| Utility Transfer | | | |
| Electricity | 190,000 | 7.382 | 1,402,580 |
| Potable Water | 88,000 | 7.382 | 649,616 |
| 3. Replacement Costs | 0 | - | <u>0</u> |
| 4. Net Present Cost (20 Year Ops) | | | \$36,932,000 |

1.7 Case 1 - Savings or (Loss)

For 50% RDF /50% Coal:

$$\begin{aligned} \text{Loss} &= \$42,619,000 - \$36,932,000 \\ &= (\$5,687,000) \end{aligned}$$

2. CASE NUMBER 2

2.1 Case 2 - Concept of Operations

Assume as a second concept that the gross plant production is 2,452,800 MBtu per year and the plant is equipped with three 150 MBtu/hr boilers. As in Case 1, only boilers 1 and 2 would be retrofitted to fire RDF. Each boiler would be fired an average of 305 days per year; therefore, boilers 1 and 2

would average 135 MBtu per hour of 90% of rated load continuously for 305 days to consume 122,000 tons per year. Boiler 3 would be used to support seasonal loads. Supporting this concept of operations, the following boiler operations would occur:

| | Boiler #1 (Retrofitted) | Boiler #2 (Retrofitted) | Boiler #3 (Retrofitted) |
|---|----------------------------|----------------------------|----------------------------|
| Gross Output (MBtu/yr) | 988,200 | 988,200 | 476,400 |
| RDF Fuel Output @ 50% of Total (MBtu/yr) | 494,100 | 494,100 | NA |
| RDF Input @ 72% Eff. (MBtu/yr) | 686,250 | 686,250 | NA |
| Tons of RDF | 61,000 | 61,000 | NA |
| <u>Btu</u> 5625 x 2000 | | | |
| Total RDF Requirements per Year | 122,000 Tons | | |
| Total MSW Processed per Year | 145,273 Tons | | |

$$\text{Plant capacity} = \frac{145,273 \text{ Tons}}{8 \text{ hr/shift} \times 2 \text{ shifts} \times 260 \text{ days/yr}} = 35 \text{ Tons/hr}$$

2.2 Case 2 - Estimate of MSW Plant Capital Investment Costs

| | <u>First Year</u> | <u>Second Year</u> |
|--|--------------------|--------------------|
| Process Plant Equipment | \$ 0 | \$2,842,000 |
| Support Facility | 1,561,000 | 1,839,000 |
| Sub total | <u>1,561,000</u> | <u>4,681,000</u> |
| Contingency (10%) | 156,100 | 468,100 |
| Sub total | <u>1,717,100</u> | <u>5,149,100</u> |
| Engineering Costs | 700,000 | 398,592 |
| Sub total - Installation | <u>2,417,100</u> | <u>5,547,692</u> |
| Organization and Startup | 30,000 | 300,000 |
| Sub total | <u>2,447,100</u> | <u>5,847,692</u> |
| Discount Factor | x 0.954 | x 0.867 |
| Net Present Value (NPV) | <u>\$2,334,000</u> | <u>\$5,069,949</u> |
| Total NPV Capital Investment | | <u>\$7,403,949</u> |
| <u>Annual Capital Investment Recovery Charge . .</u> | <u>\$1,002,973</u> | |

The distribution of the total NPV over the 20-year production period to recover costs:

$$\text{Discount Factor} = 22 \text{ Yr Factor} - 2 \text{ Yr Factor} \\ \text{or } 9.203 - 1.821 = 7.382$$

$$\text{Annual Charge} = \frac{\text{Total NPV}}{\text{Discount Factor}} = \frac{\$7,403,949}{7.382}$$

$$= \$1,002,973 = \$1,003,000$$

2.3 Case 1 - Annual MSW Facility Production Cost

| | <u>Operating Cost</u> | |
|------------------------------------|-----------------------|------------------------|
| | <u>First 10 Years</u> | <u>Second 10 Years</u> |
| <u>Operations Costs</u> | | |
| Labor ¹ | \$384,000 | \$384,000 |
| Fuel | 30,000 | 30,000 |
| Material | 50,000 | 50,000 |
| <u>Maintenance Costs</u> | | |
| Labor ² | 96,000 | 138,000 |
| Material ³ | 200,000 | 320,000 |
| Contracts ⁴ | 0 | 100,000 |
| <u>Utilities</u> | | |
| Electricity ⁵ | 122,000 | 122,000 |
| Water ⁶ | 100,000 | 100,000 |
| Landfill disposal | 60,000 | 60,000 |
| <u>Subtotal (Direct)</u> | <u>1,042,000</u> | <u>1,304,000</u> |
| <u>Overhead</u> | | |
| Supervision ⁸ | 58,000 | 58,000 |
| Administrative ⁹ | 54,000 | 58,000 |
| Payroll Acceleration ¹⁰ | 184,000 | 198,000 |
| Insurance ¹¹ | 40,000 | 40,000 |
| Taxes ¹² | 160,000 | 160,000 |
| G&A ¹³ | 160,000 | 160,000 |
| Capital Invest. Recovery | 1,003,000 | 1,003,000 |
| <u>Subtotal (Overhead)</u> | <u>1,659,000</u> | <u>1,677,000</u> |
| <u>Total (Direct + Overhead)</u> | <u>2,701,000</u> | <u>2,981,000</u> |

| | <u>Operating Cost</u> | |
|--|-----------------------|------------------------|
| | <u>First 10 Years</u> | <u>Second 10 Years</u> |

Less Credits

| | | |
|--|--------------------|---------------------|
| Tipping Fee @ \$15/Ton MSW [145,273 Tons x \$15] | (2,179,000) | (2,179,000) |
| Ferrous Metal @ \$15/Ton [145,273 Tons x 0.0461 x \$15] | (100,000) | (100,000) |
| <u>Subtotal (Credits)</u> | <u>(2,279,000)</u> | <u>(2,279,000)</u> |
| <u>Net Production Costs</u> | 422,000 | 702,000 |
| <u>Profit (16% of Gross Cost)¹⁴</u> | <u>432,000</u> | <u>477,000</u> |
| <u>Total Annual Production Cost</u> | <u>\$ 854,000</u> | <u>\$ 1,179,000</u> |
| <u>Cost per Ton of RDF 2</u> | <u>\$7.00/Ton</u> | <u>\$9.66/Ton</u> |

Notes:

1. Plant operating labor based upon 2080 MH/yr x \$10.26/MH direct cost for 9 people per shift x 2 shifts.
2. Maintenance Labor based upon 4.5 people 2080 MH/yr x \$10.26/MH direct for first 10 years and 6.5 people 2080 MH/yr x \$10.26/MH for the second 10 years.
3. Maintenance materials and supplies based upon 2.5% of capital investment cost first 10 years and 4% during the second 10 years.
4. Maintenance overhaul contracts required during second 10 years due to advanced deterioration of equipment.
5. Electricity based upon 2,221,120 kWh demand @ 5.5¢ per kWh.
6. Water @ \$0.80/1000 gals.
7. Plant Process discard; i.e., nonferrous materials and bulky refuse @ \$5000 per month.
8. Plant Supervision @ 15% of plant operating labor.
9. Administrative labor @ 10% of total direct and supervision labor.
10. Payroll burden @ 31% of total labor.
11. General insurance fee @ 0.5% of capital investment.
12. Taxes computed @ 2% of capital investment.
13. G&A expenses including accounting, etc, based on 2% of capital investment.
14. Profit equals 16% of total direct plus overhead before credit deduction.

2.4 Case 2 - Capital Investment Costs for RDF Storage and Conveyor Sub-
systems and Boiler Retrofit

RDF Storage and Conveyor System

| | |
|----------------------------------|-------------|
| Atlas Storage Bin (1000 Ton Cap) | \$1,680,000 |
| Storage Support Structure | 850,000 |
| Pneumatic Conveyor Vault | 60,000 |
| Pneumatic Conveyor | 350,000 |
| Subtotal | \$2,940,000 |

Boiler Retrofit

| | |
|--------------------------------|-------------|
| Boiler Modifications | 650,000 |
| Soot Blower System Mods | 60,000 |
| Process Control & Instruction | 110,000 |
| Ash Handling System Mods | 100,000 |
| Structural and Support System | 60,000 |
| Coal Burner and Feed Mods | 200,000 |
| Mechanical and Electrical Mods | 900,000 |
| Subtotal | \$2,080,000 |

| | |
|-------------------------------------|-------------|
| <u>Subtotal Specific Work</u> | 5,020,000 |
| <u>Contingency (10%)</u> | 502,000 |
| <u>Subtotal Plant Modifications</u> | 5,522,000 |
| <u>Engineering Cost (8%)</u> | 441,760 |
| <u>Total Capital Investment</u> | \$5,963,760 |

Breakdown of Capital Investment Expenditures

| | <u>First Year</u> | <u>Second Year</u> |
|----------------------------------|-------------------|--------------------|
| RDF Storage and Conveyor Systems | \$1,200,000 | \$1,740,000 |
| Boiler Retrofit | 750,000 | 1,330,000 |
| Subtotal | 1,950,000 | 3,070,000 |
| Contingency (10%) | 195,000 | 307,000 |
| Subtotal | 2,145,000 | 3,377,000 |
| Engineering Costs | 300,000 | 141,760 |
| Total Capital Investment | \$2,445,000 | \$3,518,760 |

2.5 Case 2 - Net Present Value Analysis (50% RDF)

Net present cost of plant operations using 50% RDF and 50% coal in each of two 150 MBtu/hr boilers and 100% coal in the third boiler, for 20 years starting with year (+3) and ending with year (+22):

| <u>Cost Element</u> | <u>Unadjusted Cost</u> | <u>Discount Factor</u> | <u>Net Present Cost</u> |
|-------------------------------|------------------------|------------------------|-------------------------|
| Capital Investment | \$2,445,000 | 0.954 | \$2,332,530 |
| | 3,518,760 | 0.867 | <u>3,050,765</u> |
| | | | <u>\$5,383,295</u> |
| O&M Costs | | | |
| Operations Costs | | | |
| Labor | 717,535 | 7.382 | 5,296,843 |
| Fuel (Coal) | 3,333,330 | 8.873 | 29,576,637 |
| Fuel (RDF - First 10 Yr) | 854,000 | 5.328 | 4,550,112 |
| (RDF - Second 10 Yr) | 1,179,000 | 2.054 | 2,421,666 |
| Materials | 70,000 | 7.382 | 516,740 |
| Contracts | 36,000 | 7.382 | 265,752 |
| Maintenance Costs | | | |
| Labor (First 10 Yr) | 324,200 | 5.328 | 1,726,272 |
| (Second 10 Yr) | 344,000 | 2.054 | 706,576 |
| Material (First 10 Yr) | 55,000 | 5.328 | 293,040 |
| (Second 10 Yr) | 65,000 | 2.054 | 133,510 |
| Contracts (First 10 Yr) | 350,000 | 5.328 | 1,864,800 |
| (Second 10 Yr) | 450,000 | 2.054 | 924,300 |
| Overhead | | | |
| General Plant Expense | 71,000 | 7.382 | 524,122 |
| Utility Transfer | | | |
| Electricity | 240,000 | 7.382 | 1,771,680 |
| Potable Water | 130,000 | 7.382 | 959,660 |
| Net Present Value (20 Yr Ops) | | | <u>\$56,915,000</u> |

$$\frac{NPV(S)^1}{NPV(I)} = SIR = \frac{\$61,100,000 - (\$56,915,000 - \$5,383,295)}{\$5,383,295} = 1.78$$

Note 1: NPV(S) = Total Net Present Cost of Operations Only

= Net Present Cost - NPV of Investment

2.6 Case 2 - Alternate Net Present Value Analysis (50% RDF)

Net present cost of plant operations using 50% RDF and 50% coal in each of two 150 MBtu per hour boilers and 100% coal in the third boiler, based upon replacing the RDF equipment after 10 years of operations in lieu of increasing maintenance and repair activities:

| <u>Cost Element</u> | <u>Unadjusted Cost</u> | <u>Discount Factor</u> | <u>Net Present Cost</u> |
|------------------------------|------------------------|------------------------|-------------------------|
| Capital Investment | \$2,445,000 | 0.954 | \$2,332,530 |
| | 3,518,760 | 0.867 | <u>3,050,765</u> |
| | | | <u>\$5,383,295</u> |
| O&M Costs | | | |
| Operations Costs | | | |
| Labor | 717,535 | 7.382 | 5,296,843 |
| Fuel (Coal) | 3,333,330 | 8.873 | 29,576,637 |
| Fuel (RDF) | 1,024,000 ¹ | 7.382 | 7,559,169 |
| Materials | 70,000 | 7.382 | 516,740 |
| Contracts | 36,000 | 7.382 | 265,752 |
| Maintenance Costs | | | |
| Labor | 324,000 | 7.382 | 2,391,768 |
| Material | 55,000 | 7.382 | 406,010 |
| Contracts | 350,000 | 7.382 | 2,583,700 |
| Overhead | | | |
| General Plant Expense | 71,000 | 7.382 | 524,122 |
| Utility Transfer | | | |
| Electricity | 240,000 | 7.382 | 1,771,680 |
| Potaable Water | 130,000 | 7.382 | 959,660 |
| Replacement Cost | | | |
| RDF Equipment | 5,678,000 ² | 0.304 | <u>1,726,112</u> |
| Net Present Cost (20 Yr Ops) | | | <u>\$58,961,486</u> |
| | | | Say \$58,961,000 |

$$\frac{NPV (S)}{NPV (I)} = SIR = \frac{\$61,100,000 - (\$58,961,000 - \$5,383,295)}{\$5,383,295} = 1.40$$

Notes: 1. RDF Fuel adjusted by using the RDF cost for the first 10 years \$854,000 and accelerating it by the capital charge cost to fund the

replacement of \$4,136,560 worth of MSW equipment during year 13.
equal to:

$$\frac{\$4,136,650 \times 0.304}{7.382}$$

or \$854,000 + \$170,000 = \$1,024,000.

RDF Unit Price = \$8.39/ton.

2. Replacement costs of Navy-owned equipment at the end of 10 years of operations:

| | |
|--------------------------------|--------------------|
| Demolition/Facility Alteration | \$ 600,000 |
| RDF Storage and Conveyors | 2,100,000 |
| Boiler Overhauls | 2,080,000 |
| Subtotal | <u>\$4,780,000</u> |
| Contingency (10%) | 478,000 |
| Subtotal | <u>\$5,258,000</u> |
| Engineering (8%) | 420,000 |
| Total Replacement Cost | <u>\$5,678,000</u> |

2.7 Case 2 - Net Present Value Analysis (25% RDF)

The net present cost of plant operations using 25% RDF and 75% coal in each of two 150 MBtu per hour boilers and 100% coal in the third boiler, for 20 years starting with year (+3) and ending with year (+22):

| <u>Cost Element</u> | <u>Unadjusted Cost</u> | <u>Discount Factor</u> | <u>Net Present Cost</u> |
|--------------------------|------------------------|------------------------|-------------------------|
| Capital Investment | \$2,445,000 | 0.954 | \$2,332,530 |
| | 3,518,760 | 0.867 | <u>3,050,765</u> |
| | | | <u>\$5,383,295</u> |
| O&M Costs | | | |
| Operations Costs | | | |
| Labor | 717,535 | 7.382 | 5,296,843 |
| Fuel (Coal) | 4,346,496 | 8.873 | 38,566,459 |
| Fuel (RDF-First 10 Yr) | 1,320,000 ¹ | 5.328 | 7,032,960 |
| (RDF-Second 10 Yr) | 1,416,000 ¹ | 2.054 | 2,908,464 |
| Materials | 70,000 | 7.382 | 516,740 |
| Contracts | 36,000 | 7.382 | 265,752 |
| Maintenance Costs | | | |
| Labor (First 10 Yr) | 324,200 | 5.328 | 1,726,272 |
| (Second 10 Yr) | 344,000 | 2.054 | 706,576 |
| Material (First 10 Yr) | 55,000 | 5.328 | 293,040 |
| (Second 10 Yr) | 65,000 | 2.054 | 133,510 |

| <u>Cost Element</u> | <u>Unadjusted Cost</u> | <u>Discount Factor</u> | <u>Net Present Cost</u> |
|--|------------------------|------------------------|-------------------------|
| Maintenance Costs (Cont'd) | | | |
| Contracts (First 10 Yr) | 350,000 | 5.328 | 1,864,800 |
| (Second 10 Yr) | 400,000 | 2.054 | 821,600 |
| Overhead | | | |
| General Plant Expense | 71,000 | 7.382 | 524,122 |
| Utility Transfer | | | |
| Electricity | 240,000 | 7.382 | 1,771,680 |
| Potable Water | 130,000 | 7.382 | 959,660 |
| | | | <u>\$68,771,773</u> |
| Net Present Cost (20 Yr Ops) | | Say | \$68,772,000 |

Savings or (Loss):

$$\begin{aligned} \text{Loss} &= \$68,772,000 - \$61,100,000 \\ &= (\$7,672,000) \end{aligned}$$

Notes: 1. RDF Fuel costs based upon a single shift operation. See case 1 MSW Plant operating costs.

2.8 Case 2 - Net Present Value Analysis (100% Coal)

Net present cost of plant operations using 100% coal in each of three 150 MBtu boilers for 20 years starting with year (+3) and ending with year (+22):

| <u>Cost Element</u> | <u>Unadjusted Cost</u> | <u>Discount Factor</u> | <u>Net Present Cost</u> |
|--------------------------|------------------------|------------------------|-------------------------|
| Capital Investment | \$ 0 | 1.000 | \$ 0 |
| O&M Costs | | | |
| Operations Costs | | | |
| Labor | 717,535 | 7.382 | 5,296,843 |
| Fuel (Coal) | 5,282,953 | 8.873 | 46,937,753 |
| Materials | 70,000 | 7.382 | 516,740 |
| Contracts | 36,000 | 7.382 | 265,752 |
| Maintenance Costs | | | |
| Labor | 294,000 | 7.382 | 2,170,308 |
| Material | 40,000 | 7.382 | 295,280 |
| Contracts | 320,000 | 7.382 | 2,362,240 |

| <u>Cost Element</u> | <u>Unadjusted Cost</u> | <u>Discount Factor</u> | <u>Net Present Cost</u> |
|--|------------------------|------------------------|-------------------------|
| Overhead | | | |
| General Plant Expense | 71,000 | 7.382 | 524,122 |
| Utility Transfer | | | |
| Electricity | 240,000 | 7.382 | 1,771,680 |
| Potable Water | 130,000 | 7.382 | 959,660 |
| | | | <u>\$61,100,378</u> |
| Net Present Cost (20 Yr Ops) | | Say | \$61,100,000 |

2.9 Case 2 Savings or (Loss)

a. For 50% RDF/50% coal and accelerated maintenance and repair program:

Savings = \$4,185,000

SIR = 1.78

b. For 50% RDF/50% coal and equipment replacement program:

Savings = \$2,139,000

SIR = 1.40

c. For 25% RDF/75% coal:

Loss = (\$7,672,000)

2.10 Case 2 - Programmed SIR

If an SIR of 1.0 is established as the minimum, then the maximum RDF unit cost that could be permitted would equal:

a. For an accelerated maintenance/repair program:

| | | |
|------------------------------|---|-------------------|
| Max Net Present Cost | = | \$61,100,000 |
| Less (\$56,915,000-NPV(RDF)) | | <u>49,943,000</u> |
| Available for RDF | | \$11,157,000 |

Available Annually

for RDF = $\frac{\$11,157,000}{7.382}$ = \$1,511,379

Max RDF Unit Cost = $\frac{\$1,511,379}{122,000 \text{ Tons}}$

RDF Unit Cost to attain an SIR - 1.0 is equal to \$12.39/ton.

b. For an equipment replacement program:

| | | |
|------------------------------|---|-------------------|
| Max Net Present Cost | = | \$61,100,000 |
| Less (\$58,961,000-NPV(RDF)) | | <u>51,402,000</u> |
| Available for RDF | | \$ 9,698,000 |

Available Annually

for RDF = $\frac{\$9,698,000}{7.382}$ = \$1,313,736

Max RDF Unit Cost = $\frac{\$1,313,736}{122,000 \text{ Tons}}$

RDF Unit Cost to attain an SIR = 1.0 is equal to \$10.77/Ton

END

FILMED

12-84

DTIC