

MICROCOPY RESOLUTION TEST CHART
NATIONAL BUREAU OF STANDARDS-1963-A

1. REPORT NUMBER AFOSR-TR- 84-0787		3. TYPE OF REPORT & PERIOD COVERED Final Report 5	
4. TITLE (and Subtitle) The Role of Physical and Physiological Capacities and Their Modification on the Tolerance to Various Stress Experienced by Air Force Personnel		6. PERFORMING ORG. REPORT NUMBER 5	
7. AUTHOR(s) Ed Bernauer, Ph.D. Paul A. Mole, Ph.D. William C. Adams, Ph.D.		8. CONTRACT OR GRANT NUMBER(s) AFOSR 78-3510	
9. PERFORMING ORGANIZATION NAME AND ADDRESS Physical Education Department University of California Davis, CA 95616		10. PROGRAM ELEMENT, PROJECT, TASK AREA & WORK UNIT NUMBERS 2312/A1 PEG/102F	
11. CONTROLLING OFFICE NAME AND ADDRESS Air Force Office of Scientific Research /NL Bolling Air Force Base Washington, DC 20332		12. REPORT DATE 6/31/84	
<i>(If different from Controlling Office)</i>		13. NUMBER OF PAGES 160	
		15. SECURITY CLASS. (of this report) Unclassified	
		15a. DECLASSIFICATION/DOWNGRADING SCHEDULE	

AD-A145 779

Approved for public release, distribution unlimited

17. DISTRIBUTION STATEMENT (of the abstract entered in Block 20, if different from Report)

DTIC ELECTE
SEP 25 1984

18. SUPPLEMENTARY NOTES

19. KEY WORDS (Continue on reverse side if necessary and identify by block number)

Orthostatic tolerance	Cortisol	Exercise training
Blood resistivity	PRA	L-1 Maneuver
Aerobic capacity	Echocardiography	
Anthropometric	Impedance rheography	
Catecholamines		

20. ABSTRACT (Continue on reverse side if necessary and identify by block number)

The final report addresses advances in anthropometric and physical conditioning that will improve physical fitness and orthostatic tolerance related to improvement in handling high sustained G (HGS) stress. Topics include: (1) Man, exercise and orthostasis, (b) Animal model response to HGS; and Man, thermal stress and physical performance. Five years of work are condensed in the report.

DTIC FILE COPY

TABLE OF CONTENTS

I. GENERAL OVERVIEW -----	1
II. PROJECT AIMS AND OBJECTIVES -----	5
III. COMPILATION OF ABSTRACTS -----	10
IV. SUMMARY OF COMPLETED STUDIES -----	29
V. FINAL SERIES OF STUDIES: COMPLETED AND IN PROGRESS -----	42
VI. PUBLICATIONS AND MANUSCRIPTS IN PREPARATION -----	68
VII. PROFESSIONAL PRESENTATIONS, DEGREES AWARDED -----	69
VIII. PRINCIPAL INVESTIGATORS AND ASSOCIATES -----	72
IX. COLLABORATIVE ASSOCIATIONS -----	73
APPENDIX -----	74

SECTION I

A. GENERAL OVERVIEW

Tolerance capability in a HSG environment is a function of the inherent G-tolerance, anti-G suit function and the physical straining maneuver called M-1. Advances in design of anti-G valve technology has significantly improved anti-G suit function. Inherent or relaxed G-tolerance appears to be less responsive to modification than the active type associated with the M-1 straining maneuver. Since the M-1 is learned, its effectiveness is dependent upon applied skill, and once learned remains fairly constant thereafter. What appears modifiable then to a significant degree is the physical conditioning dependent G-tolerance during aerial combat maneuvers (ACM). The specificity of this physical conditioning and the correspondence of the physiological stress of HSG during ACM to specific programs of physical conditioning are the primary objective of the present research. Schemata below provides an overview of the anthropometric, physical conditioning, and tolerance factors involved. Related environmental factors, particularly the effects of thermal conditions on the physiological adaptations to exercise conditioning programs and on physical performance are also being investigated.

The first of two schemata presented below (Figure 2) gives a conceptual overview of the investigative project. It perceives tolerance to high sustained gravity (HSG) as composed of three interdependent components, viz., acceleration, L-1 straining maneuvers, and orthostasis. All three tolerance components were investigated in the Human Performance Laboratory (HPL) at UC Davis or in cooperation with agency laboratories such as the Aerospace Laboratory at Brooks Air Force Base, San Antonio. The human factors of research interest in a generalized man-aircraft system include selected physical and physiological characteristics known to be associated with functional capacity or tolerance.

It was the purpose of the present series of studies to determine the relationships between basic physical and physiological characteristics and the components of tolerance; and to identify effective exercise regimens to modify this tolerance.

The second schemata below summarized results of completed studies and current investigative efforts (Figure 2). An observation made initially in our laboratory, revealed that high levels of aerobic or endurance training induced by running and associated with cardiovascular fitness resulted in low orthostatic tolerance. A subsequent investigation conducted by a Ph.D. student, L. Epperson at SAM - Brooks AFB, San Antonio, corroborated this finding under $+G_z$ at HSG. Further, he revealed a significant benefit of weight training to $+G_z$ tolerance. Based on these observations, we have pursued two principal lines of research 1) To elucidate the specificity of exercise training as it effects orthostatic tolerance and 2) To begin to understand the underlying mechanisms and its neuroendocrine control as it is affected by exercise training.

B. Characteristics of Heart and Skeletal Muscle Impairments Induced by High Sustained $+G_z$ Acceleration in Chickens

Introductory Statement Concerning the Problem

Our research on this project has shown that there are three subpopulations

of single comb white leghorn (SCWL) chickens with respect to high sustained gravitational (HSG) tolerance at $+6G_z$; they are a low HSG tolerance group with tolerance mode of 3 minutes, an intermediate group with tolerance mode of 24 minutes and a high tolerance group with a mode of 58 minutes. A second important result of our research is the finding that there is a high positive correlation ($r=.853$) between HSG tolerance and run time to exhaustion (RTE, endurance capacity) for these birds. Also, low HSG tolerance birds (7.2 ± 1.0 min) have a significantly lower mean RTE (20.8 ± 1.3 min) compared to the RTE of the combined intermediate and high tolerant groups (HSG tolerance = 37.1 ± 5.8 min) of 31.9 ± 2.6 min. Our exercise training studies show that an adaptive increase in endurance capacity (RTE) is accompanied by a dramatic increase in HSG tolerance; also one exposure to acceleration stress at $+6G_z$ to bradycardia endpoint leads to a marked increase in RTE within one day of exposure and this increase in endurance lasts for at least 28 days in 59% of the birds (high HSG tolerant group). Thus, when % HSG tolerance is related to % RTE a high positive correlation of 0.60 is found. Smith et. al. (4) have shown that HSG tolerance is enhanced with chronic low $+G_z$ centrifugation, these more tolerant birds also have a greater exercise capacity. These findings are consistent with those on the effects of weightlessness and also bedrest in that both cause lower HSG tolerance and endurance capacity. Finally, we found the magnitude of the increase in endurance capacity (RTE) was the same whether produced by centrifugation plus exercise or exercise alone. Therefore, the processes and traits (functional capacities) caused to adapt by both stresses are probably the same, since the effects on RTE were not additive. These findings suggest the plausibility of the following hypothesis, that there are measurable common physiological traits which are primary for HSG tolerance as well as high endurance capacity.

C. Sexual Comparison of Thermoregulatory Mechanisms during Prolonged Work in Ambient Heat Stress

The present thermal investigation hypothesized that if males rely more on maximal sweat rate to thermoregulate, they should do better in hot-dry conditions, whereas females, who allegedly have greater cardiovascular lability should have an advantage in warm-humid conditions. Twelve well trained individuals - 6 males and 6 females of similar aerobic capacities, 65 and 55 ml/min kg, respectively, served as subjects. All have undergone 6 days of heat acclimatization and repeated measurements of VO_2 blood volume and fractions, cardiac output, body temperatures, sweat rates and blood electrolytes were made during the course of the experiments.

FIGURE 1. PHYSICAL AND PHYSIOLOGICAL CHARACTERISTICS RELATED TO ORTHOSTATIC TOLERANCE: EFFECT OF

SPECIFIC PHYSICAL CONDITIONING PROGRAMS

PHYSICAL & PHYSIOLOGICAL CHARACTERISTICS

PHYSICAL CONDITIONING

BODY SIZE

STATURE

SOMATOTYPE

LIMB-TRUNK RATIOS

PHYSIOLOGICAL FUNCTION

HEART RATE/BLOOD PRESSURE/

BLOOD VOLUME/CARDIAC OUTPUT

PHYSIOLOGICAL CAPACITIES

AEROBIC CAPACITY

CV ENDURANCE

M. ENDURANCE

ANAEROBIC CAPACITY

M. STRENGTH

LEGS

ARMS

TRUNK

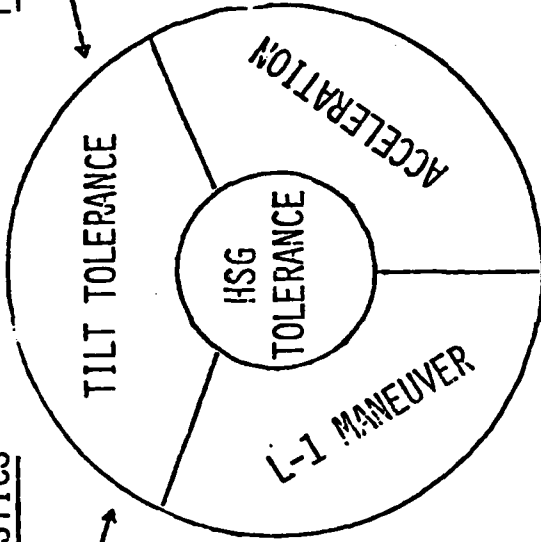

GENERAL FITNESS

ENDURANCE

STRENGTH

SPECIFIC FITNESS

ENDURANCE

AEROBIC CAPACITY

WEEKLY MILEAGE

STRENGTH

LEGS/TRUNK vs ARMS/TRUNK vs TRU

CROSS TRAINING

ENDURANCE

STRENGTH

INTERACTIONS



SUMMARY OF RESULTS THROUGH 1981

Role of Physiological Conditioning in High Sustained Gravity/Orthostatic Tolerance

1. Initial Observations
2. Completed Research
3. Current Research
4. Cooperative Research

1. INITIAL OBSERVATIONS

a. Aerobic Fitness - Counterproductive

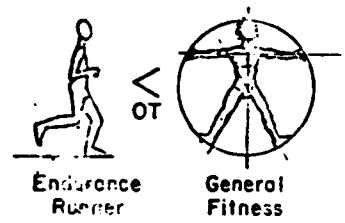

b. Inverse relationship between OT vs. Miles run/wk
 $>20 > 40 > 60$

2. COMPLETED RESEARCH

a. Cross Training - (12 wks)

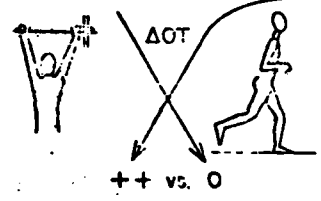

b. Specificity of Training Mode - (10 wks)

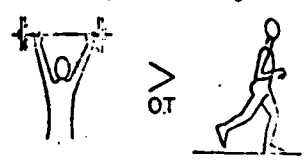

c. Energy Demands of L-1 Straining
 I. Anaerobic >>> Aerobic

3. CURRENT RESEARCH

a. Anthropometric Factors "R" OT

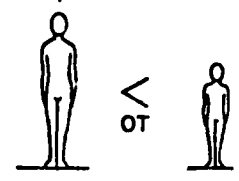

b. Physiological Factors "R" OT

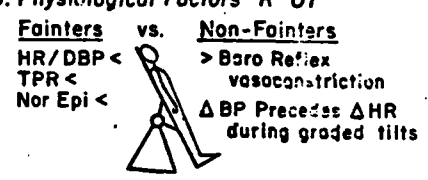

c. Physiological Mechanism?

- I. Central vs. Peripheral
 - a. Sympathetic N.S. < Heart vs. Peripheral vessels
 - b. Hormonal Control < General Systemic vs. Specific Vascular

4. COOPERATIVE RESEARCH

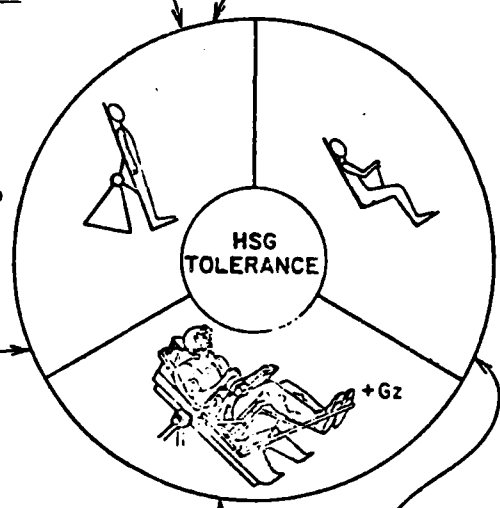
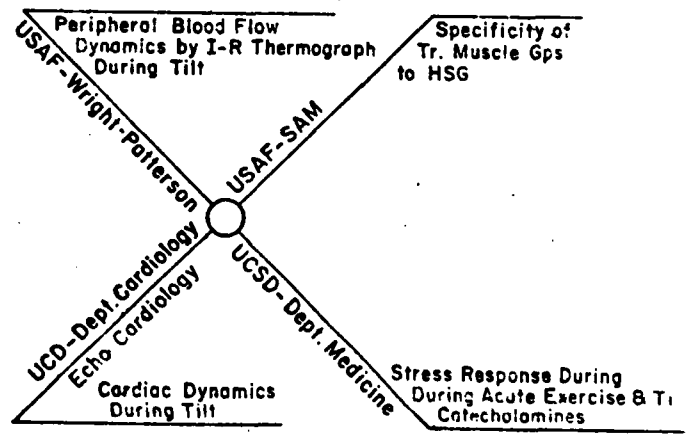

SECTION II.

PROJECT AIMS AND OBJECTIVES

A. GENERAL AIMS

The general purpose of the planned series of experiments is to determine the effect of physical conditioning on orthostatic tolerance. Recent reviews by Burton and others have emphasized the point that relaxed tolerance cannot be increased by design. They state further that the only possible avenue open for a pilot to improve his G-tolerance is by improving his physical capabilities relative to the M-1. Epperson has established the positive effect of strength training compared to endurance training on acceleration tolerance. Whinnery, interestingly, states that relaxed G-tolerance apparently does increase with age and body fat in individuals of relatively low physical condition. Current investigations in our laboratory reveal that individuals with high levels of endurance capacity have low orthostatic tolerance; further when placed in a concurrent weight training program have increased their tolerance. The basis of this tolerance change remains unclear but evidence obtained to date reveals no difference in central cardiovascular response or rate of cutaneous pooling between low tolerance (fainters) and high tolerance individuals until the manifestation of the syncopal episode.

OBJECTIVES

1. To determine the effect of anthropometric dimensions and physical conditioning on orthostatic tolerance.
2. To relate specific criteria of orthostatic tolerance (OT) obtained by laboratory measurement to performance of simulated aerial combat maneuvers (SCAM).
3. To develop an optimal regimen of physical training specific to the OT associated with SACM.
4. To evolve a basic understanding of the underlying physiological mechanisms involved in SACM and role of physical training.
5. To develop a valid yet practical test battery to measure OT as related to SACM.

B. MAN, EXERCISE AND ORTHOSTATIC TOLERANCE

1. A review of the literature reveals two critical facts concerning tolerance to a high sustained gravity (HGS), viz., 1) that a coordinated straining effort (L-1 - M-1 maneuver) are essential to maintain $+G_z$ tolerance at HGS, and 2) that little is known about the energetics or physiological consequence of the L-1 - M-1 maneuvers per se. Thus, the present study was designed to characterize the physical and physiological factors that aid the duration of the L-1 maneuver. Assumptions that the L-1 maneuver is basically aerobic was shown not to be so in preliminary experiments.

2. Since endurance training appears to reduce orthostatic tolerance to passive head-up tilt while strength training increases tolerance, we proposed to select individuals who varied in their orthostatic tolerance but could be

matched with respect to their anthropometric features - somatotype - and physiological capacities. This matching would allow a more direct assessment of the effects of a strength training program. The strength training regimen would involve a general - all around - strength training designed 1) to measure the changes in vascular conductance and capacitance and 2) to observe left ventricle function and the onset of vasovagal response. Basically two hypotheses are proposed, a peripheral vs. a central one. To the extent that strength training effects either of these vascular functions, and in turn orthostatic tolerance, i.e., vasovagal response, was primary to this aspect of the project.

3. Following the results obtained by Epperson, relating the changes in active orthostatic tolerance to changes induced by strength training, it was important to characterize strength training. A series of training studies were proposed to more sharply specify the nature of the strength training response. Two approaches were taken 1) cross training studies which imposed strength training regimen on individuals who continued to engage in a high volume endurance program and alternatively impose a high volume running program on those individuals who normally strength trained; 2) specificity of strength training which attempted to further specify the contribution of strength training on orthostatic tolerance by focusing on one of three major groups of muscle viz., upper limbs, trunk and lower limbs.

4. Given the apparent specificity of physical training on orthostatic tolerance and the underlying vasovagal response, a series of experiments were designed to understand the role of strength and endurance training on the blood pressure control system. More specifically to evaluate the effect of physical training on hormonal responses during 70° head-up tilt.

5. During the course of the project several problems related to experimental protocol or procedure required attention before the investigation could move forward. Of the several problems of this type, four deserve particular emphasis. They include 1) A study to compare the conventional 70° head-up tilt with that of progressively incremental tilt angle; the purpose was to facilitate the measurement of transient changes, 2) A study to determine the role of the central control of blood pressure - dynamics of cardiac function - by utilizing echo cardiography, 3) A study to measure transient peripheral blood changes by utilizing IR-thermography and comparing it to the conventional thermister, and 4) A study to determine the combined effects of breathing resistance and hyperoxia on aerobic work tolerance as it relates to the L-1 maneuver.

OBJECTIVES

1. Metabolic costs and physiological stress measured during exhaustive static leg effort.
 - a. To measure the energy demands of the L-1 maneuver during a controlled protocol.
 - b. To assess the aerobic and anaerobic components of the energy requirement resulting from the L-1 maneuver.
 - c. To determine the most appropriate exercise training based upon the muscle effort and energy demand.
 - d. To estimate the physiological stress associated with the L-1 maneuver based on the CV-response viz., heart rate and blood

pressure and nor-epi levels.

2. The effect of endurance vs. strength training on OT-70° head up tilt and SACM
 - a. To determine the OT-tilt tolerance of two groups of young men, highly conditioned in either endurance or strength capacity.
 - b. To assess the specific physiological responses of the two groups during tilt to establish discriminating criteria of OT.
 - c. To determine the effects of two dynamic conditioning programs viz., endurance running (moderate intensity and duration) vs. weight training (high intensity and low duration) on SACM performance.
3. Cross training of endurance trained and strength subjects; the characterization of strength training regimens.
 - a. To weight train (cross train) individuals with high functional aerobic capacity and low OT.
 - b. To endurance (cross train) individuals with high strength capacity and high OT.
 - c. To measure the changes in the control of blood pressure during tilt resulting from the cross training.
 - d. To assess the cardiovascular response to the respective training regimens and to further assess the specific roles of central vs. peripheral factors on the vasovagal response.
 - e. To compare the effects of strength training of the arms vs. the legs vs. the trunk on OT.
4. The assessment of the underlying physiological mechanisms associated with the vasovagal response.
 - a. To measure the changes in heart volumes during the course of a continuous, progressively incremented tilt to 70° tilt using a stratified sample of individuals varying in anthropometric components and physiological capacities.
 - b. To measure the cardiac dynamics of the above subject pool by echocardiography.
 - c. To measure the dynamics of peripheral pooling of the above subject pool.
 - d. To determine the plasma volume shifts and electrolyte concentrations on OT in cross trained individuals.
 - e. To determine the role of plasma renin activity (PRA) and cortisol (C) on OT of cross trained individuals.
5. Validation studies related to experimental protocol and procedures associated with the project.
 - a. To validate a progressive tilt angle test protocol as an optimal measurement of OT.
 - b. To validate the echocardiographic, impedance rheography and CO₂ rebreathing procedures to assess transient blood flow dynamics.
 - c. To validate the IR-Thermographic procedure against the conventional thermister method of measuring transient peripheral blood shifts during OT-stress.
 - d. To assess the energy cost of breathing at different ventilatory rates, and resistances with and without oxygen.

C. Characteristics of Heart, Skeletal Muscle Impairments Induced by High Sustained +6G_z Acceleration in the Chicken

Our studies have demonstrated that HSG tolerance at +6G_z to bradycardia endpoint correlates highly ($r = +0.82$) with endurance capacity (run time to exhaustion) in male SCWL chickens. This finding is the basis for our working hypothesis that certain traits which are primary for high HSG tolerance may also be those which determine high endurance capacity.

Our general aim is to identify the major determinants of HSG tolerance and endurance capacity in SCWL chickens. Since endurance is dependent of O₂ delivery and utilization capacities as well as the partition of the total energy transfer arising from the oxidation of fat stores (the sparing of glycogen used for oxidation and anaerobic glycolysis), based on our results, we hypothesize that the functional capacities (traits) which are primary for high HSG tolerance are also those which are the prime determinants of high endurance performance ability.

OBJECTIVES

1. To measure the interrelationship between HSG tolerance, endurance capacity (RTE) and maximum O₂ consumption (VO₂max).
2. To partition the energy utilization during HSG and RTE into oxidation of fat and carbohydrate components; and glycogen utilization and lactate production.
3. To characterize the ability to adapt to HSG stress and thereby minimize physiological decompensation processes which limit OT.
4. To investigate factors that ameliorate the debilitation and pathology produced by HSG.
5. To determine the adaptations which enhance HSG tolerance by exercise training.

D. Sexual Comparison of Thermoregulatory Mechanisms during Prolonged Work in Ambient Heat Stress

Given the thermally encumbering gear worn by pilots of high performance aircraft, it seemed appropriate to assess the potential for stress and its impact on physical performance. Two general aims were proposed, 1) To compare temperature responses of males and females of near equivalent body size and hopefully account more precisely for the potentially confounding variables of physical training and specific heat stress imposed, 2) To compare the heat tolerance of males vs. females, both groups having VO₂max capacities in excess of 80% of the highest ever recorded and being relatively equivalent in training state and of approximately the same body size.

OBJECTIVES

1. To measure the thermoregulatory response - T_{rec}, T_{sk}, BV, SR, and heat-content in well trained men and women under specific combinations of ambient heat load.

2. To account for the effects of body size and composition on the thermoregulatory process.
3. To more precisely account for the effect of ambient heat load per se on thermoregulatory processes by comparing the response of elite runners, male and female of equivalent body size.

III.

COMPILATION OF ABSTRACTS

A. Refers to General Project Aims viz., the investigation of anthropometric and physical conditioning on physical fitness and orthostatic tolerance.

The abstracts contained in this section were presented at the Annual Review conducted by the AFOSR. Many of these studies were also presented at national professional meetings, particularly the Aerospace and College of Sports Medicine meetings between the years 1978-1983. The time span coincides with the support period of the grant.

The abstracts are arranged under four categories:

- B. Man, exercise and orthostasis.
- C. Animal-chicken model-and response to HSG.
- D. Man, thermal stress and physical performance.
- E. Spin off studies resulting from technical problems arising from the primary studies.

The presentation for each section, in turn, follows a chronological progression and includes the major points in abstract form.

1. THE EFFECTS OF BODY SOMATOTYPE AND TRAINING MODALITIES ON ORTHOSTATIC TOLERANCE. E.M. Bernauer and G.R. Mangseth, Department of Physical Education, University of California, Davis, CA 95616.

A saddle supported passive tilt was used to characterize eight subjects as either fainters or non-fainters. Four of the eight subjects, ectomorphic and endurance trained, experienced syncopal reactions as confirmed from blood pressure and heart rate recordings indicating bradycardia and abrupt decline in mean arterial pressure. The four non-fainters varied in their degree of physical activity from sedentary to moderately active, and could be classified mesomorphic. The mean $\dot{V}O_2$ max of the fainters was 66.8 ml/kg and 52 ml/kg-min for non-fainters. Non-fainters had a mean HR of 54 b/min and Pa of 86.1 mmHg at rest compared to 43.3 b/min and Pa of 87.8 mmHg for the fainters. The HR rose steadily to 83 b/min after 30 min of tilt, while the syncopal group reached a mean maximal of 67 b/min. Pa increased above 100 mmHg in the non-fainters during tilt compared to slight rises or no change from resting values in the syncopal group. Stroke volume estimated from chest impedance changes, declined 33.7% prior to syncope compared with a 47.2% drop after 30 min of tilt in the non-fainters. All subjects, with one exception, showed a decline in cardiac output following tilt; -14.8% and -11.4% for non-fainters after 30 min and fainters just prior to syncope, respectively. TPR increased -30% above rest in both groups.

Syncope appears not to be related to an inability to maintain venous return and adequate cardiac output. The non-fainters showed greater relative declines in both stroke volume and cardiac output after 30 min of tilting than did the fainters just prior to syncope, yet manifested no signs of syncope. Nor does syncope appear to be precipitated by an inordinately low cerebral blood flow. Although the Pa of fainters was lower than non-fainters, it was adequate to maintain eye-level blood pressure and prevent cerebral ischemia. This would suggest some factor other than cerebral ischemia is responsible for the breakdown of CNS blood pressure control.

The present data base is being expanded using recently modified techniques which emphasize the measurement of fluid shifts within the body during the tilt maneuver by various procedures validated against the Whitney strain gauge procedure. Measurement of lower body pooling, including the splanchnic region, is done by impedance rheography; limb pooling by the Whitney strain gauge. Blood volume is measured by a carbon monoxide dilution technique prior to tilting. This plus hematocrit and hemoglobin measurements during the tilt procedure allow estimation of plasma fluid loss during tilt. Finally, a measurement of the catecholamine response to tilt is in progress.

Ongoing research using the above techniques will attempt to identify four subject samples: 1) the ectomorphic endurance trained individual; 2) the ectomorphic sedentary individual; 3) the mesomorphic weight trained individual, and 4) the mesomorphic, sedentary individual. The specificity of training on cardiovascular response to tilting is being studied by using a 2 x 2 cross-training approach. The endurance trained individuals will undergo weight training in addition to their endurance training. The mesomorphic weight lifters will engage in endurance training in addition to their weight lifting programs. Response to tilt will be assessed before and after such training.

2. THE EFFECT OF PHYSICAL CONDITIONING ON $+G_z$ TOLERANCE

William L. Epperson

The influence of physical conditioning on tolerance to a centrifugation profile of alternating 15 second plateaus at 4.5 and 7.0 $+G_z$ was determined using 24 young men as subjects. These subjects were assigned to groups as controls (C), runners (R), and weight trainers (W); and followed a 12-week protocol of specified physical training. During this protocol, tolerance to centrifugation, maximum oxygen consumption, muscle strength, and body composition were periodically determined. Venous blood samples and fatigue assessments were taken before and after the SACM tolerance tests at the beginning and end of the study. SACM tolerance was defined as the total time that a subject could withstand continuous exposure to the centrifugation profile as determined by his voluntary endpoint from fatigue or 50% central light loss. The $+G_z$ tolerance of the runners and controls increased at an average rate of 4 seconds per week during the course of the experiment. On the other hand, the weight trainers increased their G tolerance at an average rate of 15 seconds per week. The differences between group W and groups C and R were statistically significant at the 5% level. Significant correlations were found between both sit up and arm curl training weights and SACM tolerance times; and the exponential relationship was found to give higher correlation coefficients than the rectilinear relationship. No significant relationship was found between plasma volume shift and SACM tolerance time. Fatigue scores indicate that group W subjects take longer to reach a given level of fatigue than did the subjects of the other groups. It appears therefore that a physical conditioning program of weight training will improve one's tolerance to repeated and prolonged exposure to high $+G_z$ loads.

3. PHYSIOLOGICAL RESPONSES TO L-1 STRAINING MANEUVER. E.M. Bernauer and J.F. Harrah, Department of Physical Education, University of California, Davis, CA 95616.

The purpose of this study is to separate the metabolic responses to +Gz accelerations into two components: Those due to the acceleration stress itself and those due to the anti-G maneuvers. To this end, a sessile mock-up was constructed, consisting of an aircraft seat interfaced with an adjustable force plate. The subject, seated and secured, maintained a fixed leg-extension workload (at 35, 55, and 75% of measured maximal extension) while performing L-1 straining maneuvers on a 4-6 second cycle until voluntary exhaustion. Heart rate, respiratory gases, eye-level systolic blood pressure, blood gases, and other blood lactate and catecholamines were monitored during the L-1 and a 10-minute recovery period. The mean times for L-1 effort were 5:00, 2:50, and 1:49, respectively for 35, 55, and 75% max leg strength.

Oxygen-uptake: $\dot{V}O_2$ showed essentially a linear increase from the beginning of L-1 until endpoint (exhaustion). This increase is on the order of 4-5 times resting $\dot{V}O_2$. Immediately after the cessation of the L-1, $\dot{V}O_2$ increased dramatically, and in some instances approached 80% of the subject's aerobic $\dot{V}O_2$ max. This transient increase of $\dot{V}O_2$ returned to near resting values 1½ to 3 minutes post L-1. The oxygen cost of work ranged from 5 to 8 ml kg⁻¹min⁻¹ at the workloads used. At 35% and 55% of the subject's $\dot{V}O_2$ max, this O₂ cost is 57% aerobic and 43% anaerobic, respectively. The fractions of aerobic and anaerobic contribution are reversed at 75% workload, being 31 and 69%, respectively. Recovery $\dot{V}O_2$ is generally elevated between 45 to 90 sec longer following the 75% workload.

End alveolar CO₂: Mean Pa CO₂ following the L-1 effort were 4.68% (3.35-5.88%), 3.96% (2.73-5.69%) and 5.04% (3.28-7.35) for 35, 55 and 75% leg strength max, respectively.

Heart Rate: HR increased in a fairly linear fashion with the time of the L-1 until max HR was reached, then plateaued until endpoint. The 55% workload elicited the highest HR (mean 123.8) followed by 75% (120.4) and 35% (101). Recovery to resting rate was achieved in approximately 2 minutes at all three workloads.

Blood Pressure: Max eye-level BP also showed an increase with workload. There was a substantial anticipatory response at 75% that did not occur at the other two workloads. Thus, the increase in BP at 75% effort was not as large as the other two workloads. Increases ranged from 1.66 to 1.81 times resting eye-level BP. Blood pressure did not follow the recovery pattern of the other physiological variables measured. Recovery time was 2-3 min at 35%, while at 75% effort the BP required at least 5 minutes for recovery.

Present research also includes blood samples collected before, during, and after the L-1. Analysis of blood lactate and catecholamine levels are in progress. Testing continues on a broad spectrum of individual somatotypes. Also in progress is the cross training of endurance and strength conditioned athletes. This latter study involves training the subjects contrary to their present training. Marathoners will lift weights for instance, and football players will engage in long-distance running.

4. COMPARISON OF ANTHROPOMETRIC AND FUNCTIONAL CHARACTERISTICS OF FAINTERS VS NON-FAINTERS TO 70° TILT WITH PILOT DATA FROM A CROSS-TRAINING STUDY Mangseth, G.R., G.W. Mack, J.F. Harrah, and Ed. Bernauer. Human Performance Laboratory, University of California, Davis, CA 95616.

Orthostatic tolerance was measured by passive 70° head-up tilt in 16 subjects classified as tolerant (non-fainters) and non-tolerant (fainters) based on their capability to tolerate 30 minutes of orthostases without reaching syncope. In addition, each subject was given a battery of anthropometric tests and selected functional tests presented in Table 1.

Table 1. Summary of anthropometric and functional characteristics

Fainters N=8	Age	Height	Weight	LBW	% Fat	VO ₂ max	ΔHct	Δ[Na ⁺]	Δ[K ⁺]
Variable	(yrs)	(cm)	(kg)	(kg)	(%)	(ml/kg min)	(%)	(mEq/l)	(mEq/l)
X	26.4	182.7	71.6	63.8	11.0	57.1	3.38	-1.04	0.05
S	7.1	6.97	9.34	8.07	3.2	9.12	1.16	1.82	0.11
Non-Fainters N=8									
X	22.5	184.6	91.8	75.6	17.2	46.9	3.72	-0.95	0.16
S	5.9	7.85	14.95	11.72	7.8	5.54	1.38	1.00	0.25
	N.S.	N.S.	<.05	<.05	<.05	<.05	N.S.	N.S.	N.S.

The subjects did not differ in age or height; height has been shown to have a significant effect on tolerance. In addition, no differences were found between the two groups in their blood Hct, [Na⁺], [K⁺], or OSMol due to tilt Δ. Significant differences were found in body weight, LBW, % fat, and VO₂max. A further classification of 30 subjects based on the volume of their aerobic training disclosed the following pattern of response to tilt - fainters/subjects tested; 1) training >60 miles/wk 9/9, 45 to 59 miles/wk 3/4, 20 to 40 miles/wk 2/5, <19 miles/wk 1/2. It appears there is a progressive increase in the number of nontolerant subjects related to the endurance training load. Catecholamine data for these subjects is being analyzed.

A second phase of this study has been the application of a training regimen on selected subjects to determine if orthostatic tolerance can be modified. Our observations reveal a high order of correlation between fainters and endurance fitness; and non-fainters and strength fitness. Presently, we have six subjects engaged in specific 12-week cross-training regimens of either endurance or strength training, designed to alter specific fitness. Two subjects have completed the training and their data appears in Table 2.

Table 2. Cross-training changes in orthostatic tolerance

	Age	Ht	Wt	LBW	% Fat	VO ₂ max	Tilt	Initial
(A)	(yrs)	(cm)	(kg)	(kg)	(%)	(ml/kg min)	Tolerance	Tr.
Pre	22	173.7	64.2	56.9	11.5	62.4	21.3	>60 miles/wk
Post			64.1	57.3	10.6	63.6	30.0	
(B)								
Pre	20	177.2	81.5	71.9	11.9	51.0	30.0	WT >3/wk
Post			83.7	72.3	13.6	55.3	30.0	

Subject A is a distance runner who continued to run but engaged in a formal program of general weight training and Subject B is a weight trainer who engaged in a 12-week program of endurance training on a bicycle ergometer. Subject A did not alter his VO₂max but the training improved his orthostatic tolerance. Subject B significantly improved his VO₂max but did not regress below the 30' limit orthostatic tolerance.

5. BLOOD RESISTIVITY CHANGES ASSOCIATED WITH ORTHOSTATIC AND EXERCISE STRESS;
IMPEDANCE CARDIAC OUTPUT IMPLICATIONS

Mangseth, G.R., Ed Bernauer. Human Performance Laboratory, University of California, Davis, CA 95616

Impedance rheography is gaining in use as a tool for monitoring cardiovascular dynamics. Estimating cardiac output with this technique requires a calculation involving a specific resistance of blood (P), usually assumed to be 150 ohm-cm. It has been shown that blood P is hematocrit (Hct) dependent. Experimental interventions that change Hct will therefore change blood P and effect the calculated cardiac output value. We have studied the Hct dependence of blood P on fresh human blood at 37°C and at 100 kHz. In addition we have examined changes in blood P with exercise and postural stress. Blood samples were obtained from 10 individuals by venipuncture. Each sample was centrifuged and remixed to give aliquots varying in Hct from 8% to 60%. The P of each sample was measured in a syringe conductivity cell. Using a least squares regression approach the following quadratic equation was found to best describe the relation between P and Hct:

$$P = 69.83 + .132 (\text{Hct}) + .0465 (\text{Hct})^2, r = .992, N = 69$$

The predictive nature of this equation was studied in 14 subjects, 9 of which were passively tilted feet down for up to 30 minutes to effect Hct changes, and 5 of which ran to exhaustion on a treadmill. Since the data for the tilt and treadmill run were similar, they have been combined. Pre-stress Hct was $43.16 + .786$ ($\bar{X} + \text{S.E.M.}$). Hct increased post-stress to $46.36 + .788$, this value was significantly different (S.D.) ($p < .001$) from the pre-stress value. Pre-stress blood P was $163.13 + 4.76$ ohm-cm. The predicted blood P was similar at $162.5 + 3.31$ ohm-cm. Blood P increased post-stress to $184.21 + 4.93$ ohm-cm, a value S.D. ($p < .001$) from the pre-stress level. Predicted blood P was $176.3 + 3.52$ ohm-cm, a value S.D. ($p < .001$) from that measured. Linear regression analysis of Hct vs P over the limited Hct range (38% - 52%) in these experiments yielded $P = 6.11 (\text{Hct}) - 99.65$, $r = .974$, $p < .001$ ($n=28$). Using this equation to predict blood P from the same data yielded a pre-stress blood P of $164.0 + 4.8$ ohm-cm and a post-stress predicted value of $183.61 + 4.82$. It would appear that the linear equation is the better predictor of blood P over the narrow range of Hct studied. Change in blood resistivity in these experiments averaged 13% of the pre-stress value. If this change remains uncorrected for impedance calculations made following the pre-stress blood HCT measurement a direct error of 13% could be introduced in the computed cardiac output values.

6. COMPARISON OF PLASMA SHIFTS AND ELECTROLYTE DATA IN PROGRESSIVE-STEPPED TILT VS FIXED-ANGLE TILT

Jack F. Harrah and Edmund M. Bernauer
Human Performance Laboratory
University of California
Davis, California 95616

In order to minimize subject discomfort and time required for the tilt table test, our objective was to develop a submaximal tilt scenario with good predictive value for hemodynamic parameters. An unexpected advantage to this test is that subjects of low orthostatic tolerance can complete the test without syncopal symptoms.

Nine adult male subjects, 21 to 40 years of age were tested on six different occasions each. The tests were 12 minute tilts of 0°, 10°, 30°, 50°, 70°, and a stepped-load tilt consisting of 3 minutes each at 10°, 30°, 50°, and 70°. The tilts were conducted in random order, and each subject was tilted no more than twice in a 7 day period. Blood samples were drawn at 0, 1, 2, 3, 4, 6, 8, 10 and 12 minutes, and were analyzed for hemoglobin content, hematocrit, sodium (Na⁺), potassium (K⁺), and chloride (Cl⁻) concentrations. Additional samples were frozen for later analysis of cortisol concentration and plasma renin activity.

Electrolyte concentrations did not vary significantly ($p < .05$) over the 12 minutes at any tilt angle, nor between angles. Plasma shifts were calculated using the equation of Costill and Fink. The 12-minute values for 10° through 70° fixed-angle tilts were -1.20%, -3.61%, -5.61%, and -10.05%, respectively, while the same data for the step tilt angles were -6.33%, -2.17%, -5.13%, and -11.03%, respectively. These differences were not significant ($p < .05$). No significant differences in plasma shift occurred in the fixed-angle tilts until minute 2, and the differences widened from minutes 2 to 8. The steady state plasma-shift value for each tilt angle was not significantly different from its neighboring angles, but was from the remaining angles; i.e., plasma shift at 12 min at 30° did not differ from that at 0° or 30°, but the 0° and 30° plasma shifts differed significantly from each other.

It appears that the progressive stepped-angle tilt offers a reasonable approximation of the fixed-angle tilt of the same duration, but with a few advantages for the study of hemodynamics. It slows down the shift of plasma from the circulating compartment, allowing greater measuring precision and as previously mentioned, it allows greater data collection time on orthostatically intolerant subjects.

7. THE CARDIOVASCULAR RESPONSE TO ORTHOSTASIS IN MEN: VARIATIONS IN ORTHOSTATIC TOLERANCE

Edmund M. Bernauer, John G. Graham, and Jack F. Harrah
Human Performance Laboratory
University of California
Davis, California 95616

The purpose of the study was twofold: (1) to identify anthropometric and physiological parameters related to orthostatic tolerance, capable of distinguishing fainters from non-fainters as operationally defined and (2) to validate a progressively incremental tilt against a conventional 70° head-up tilt to more sharply detail the cardiovascular response in a normal group of young male adults.

The design and format of the study included cardiovascular response of young adult male subjects during head-up tilt. The orthostatic induced stress to the cardiovascular system was assessed by heart rate and blood pressure measurements. The peripheral vascular resistance was assessed by monitoring changes in cutaneous circulation with infrared thermovision. Measurements were made before, during and immediately after each of two tilt formats, viz., 70° head-up for 40 minutes or progressive incremental tilts at 10°, 30°, 50°, and 70° for two minutes each. A general anthropometric profile was made of each subject prior to the tilts to characterize his body size - composition and physiological response under standard conditions.

The differences between fainters and non-fainters to tilt tolerance can be summarized under four main points. No significant differences were found between the two groups for anthropometric and resting cardiovascular measurements. The mean blood pressure differed significantly between the two groups during progressive tilt ($p < .05$) being (103/72) for the fainters and (115/84) for the non-fainters; pulse pressure was comparable for the two groups. However, during graded tilt, there was a significant difference in pulse pressure between the two groups at angles less than 70°. And finally, non-fainters appear to benefit from a stronger systole, increased peripheral resistance and a greater stroke volume at tilt angles less than 70°.

1. THE EFFECTS OF ACUTE $+6G_z$ ACCELERATION STRESS ON ENDURANCE PERFORMANCE OF MALE CHICKENS: INVOLVEMENT OF OXIDATIVE CAPACITY IN HEART AND LEG MUSCLES. P.A. Molé and R.G. Holly, Department of Physical Education, University of California, Davis, CA 95616.

Acute cardiovascular, respiratory, metabolic and muscular functions are profoundly affected by gravitational fields which could induce pathological dysfunctions. Smith et al. (USAF Interim Final Report, 1977) reported that a single $+6G_z$ acceleration to a bradycardia endpoint induced a moderate incidence of lesions including subendocardial hemorrhaging in hearts of adult male chickens. However, whether such heart lesions alter cardiac performance and functional capacity and whether any dysfunction is transient or chronic is not known.

Since endurance performance is directly related to cardiac Q_{max} and oxidative capacity of skeletal muscles, any acceleration-induced decrease in cardiac Q_{max} and oxidative capacity of muscle could diminish exercise capacity. Studies were designed to assess the effect of a single centrifugation at $+6G_z$ on endurance capacity and to relate measured changes with those recorded for oxidative capacity of the heart and leg muscles of adult male white leghorn. The experimental protocol first established the endurance capacity by a TM run to exhaustion 2-3 times weekly, followed by centrifugation at $+6G_z$ to a bradycardia endpoint of 180 bpm one week later. Run time to exhaustion (RTE) was re-determined 1, 7, 14, and 28 days post-acceleration (PtA). Oxidative capacity of heart and leg muscles were measured on PtA-36 following re-centrifugation and sacrifice on PtA-35. RTE of a control group of birds (C) was determined on weekly intervals over the course of the study and also sacrificed to determine oxidative capacities of heart and leg muscles.

Of a total of 7 birds accelerated thus far, 3 (Group A) had reduced RTE of 17% and 4 (Group B) had an increased RTE of 32.9% above their pre-acceleration (PrA) level one day following the acceleration stress. Although the number is small, these changes appear significant based on high work test-retest reliability ($r=0.91$, $n=17$) and the mean RTE for RTE for the first work trial of 22.9 ± 1.4 min was not significantly different from that of the second trial of 22.0 ± 1.3 min. These results indicate that RTE is highly reproducible and possible to detect a significant change in RTE of about 3 min or 11% of the mean RTE at the $P=.05$ level. At day 7, RTE increased for both groups of birds amounting to 33.5% for Group A and 56% above the PrA value for Group B. Day 14 PtA results are complete only for Group A, and the RTE increased further to 44.7% of the PtA control. The single bird tested at day 14 PtA had a RTE 62.5% higher than his PrA control as compared to 56.3% at day 7. Group C which was exhausted weekly showed no trend on RTE. These preliminary findings suggest that acceleration stress produces a transient decrease in endurance performance in only some birds. However, to date all animals stressed show a rapid adaptive increase in exercise capacity through 2 weeks. The physiological bases for the group differences in the time course of the adaptive increase in performance is not known and requires further study.

2. Status of Characterization of Heart and Skeletal Muscle Impairments Induced by High Sustained +G_z (HSG) Acceleration in the Chicken 19

Investigators: Paul A. Molé, Robert Holly, Thomas Barstow, and Bonnie Anderson

Introduction: The following report represents a summary of the research completed during the 1½ years that the AFOSR has funded this project. Our findings and discussion are presented here as discrete studies to help your understanding of our results and to facilitate your assessment of our progress.

Endurance Performance in Male Chickens
P.A. Molé and R.G. Holly

The purpose of this study was to develop an exercise test which could be used to assess the maximum O₂ uptake and also endurance capacity of chickens while exercising on a motor-driven treadmill. A multistage protocol was adapted in which the speed was initially set at 20 m/min (0 grade) and then increased to 30 m/min at min 2 and to 40 m/min at min 4. At minute 6, the speed was held at 40 m/min and the grade was increased to 3. Thereafter the grade increased 3° at 5 minute intervals at minutes 11, 16, and 21. The bird continued to run until exhausted at this last stage of 40 m/min, 12° incline. A total of 28 male white leghorn chickens (age = 36 mo) were given the endurance performance test (EPT) and run time to exhaustion (RTE) was determined twice with one week between tests. The mean RTE₁ was 25 min with SEM = ± 2 min. RTE₂ given one week later was 25 ± 2 min. The coefficient of determination (r²) was high and equal to 0.933, indicating a high test-retest reliability. The mean difference between RTE₁ and RTE₂ was zero and was normally distributed. The standard error of difference was ± 1.5 min and indicated that a difference between RTE's of 0 + 3 minutes would be statistically significant at P = .005. Therefore, the EPT is highly reducible and can readily detect small changes in endurance capacity of chickens.

3. Metabolic Responses of Male Chickens to Maximum Exercise
P.A. Molé, R.G. Holly and T.J. Barstow

This study was designed to determine the maximum O₂ uptake of chickens and secondly to begin characterizing the physiological and metabolic responses of the chickens during exercise to exhaustion using the endurance performance task (EPT) developed in the first study.

Since techniques for measuring O₂ consumption and CO₂ production had not been developed, only cloacal temperature, heart rate, blood lactate and hematocrit (Hct) were measured during the first year. It was found that heart rate rapidly increased and reached a maximum of 399 ± 5 bpm at 6 min of exercise, where the birds were performing at 40 m/min (zero grade), and it did not increase further as grade was increased so that heart rate at exhaustion was 406 ± 5 bpm (40 m/min, 12° incline). The lack of an increase in heart rate with grade suggested that cardiac output and O₂ delivery had attained their maxima at 40 m/min, zero grade. Subsequent studies reported below confirmed this preliminary suggestion.

Cloacal temperature (T_c) also increased as the birds performed the EPT and was found to be closely described by:

$$T_c = 41.4 t^{0.0087}$$

where t is time in minutes. Peak T_c at exhaustion was 42.7 ± 0.1°C for the 28 male birds studied. Other studies at an ambient temperature of 26°C (instead of the usual 21°C) showed that T_c rose more rapidly and attained a high level (43.2 ± 0.2 versus 42.6 ± 0.2°C). Heart rate also attained a high level (432 ± 13 vs 424 ± 3) at exhaustion. These results indicate that peak heart rate and T_c are determined by ambient temperature and further that neither physiological parameter

are at the animal's maximum. Therefore, they are not limiting the performance ability of the bird.

The Hct was $44.4 \pm 9\%$ at rest and at exhaustion had decreased to 41.2 ± 0.7 (or $-7.3 \pm 1.8\%$), thus indicating that the EPT had produced an hemaconcentration presumably due to an efflux of plasma water.

Blood lactate sampled from the brachial vein was 2.15 ± 0.15 mM at rest and increased to 4.65 ± 0.16 mM at exhaustion. This 67% increase in [lac] was much smaller than the 10 to 15 fold increase that was expected. We suggested that either lactate was rapidly and efficiently cleared or that glycogen was markedly depleted and thereby severely limited lactate production when the animals became exhausted and could not continue to perform. Some preliminary data reported below suggest the latter as the most likely reason for the low [lac] at exhaustion, but additional studies are needed to elucidate the bases for this unusual response of chickens.

During the current granting year (1979-80) methods for measuring $\dot{V}O_2$ and $\dot{V}CO_2$ of chicken while performing the EPT on the treadmill have been developed and studies have been undertaken to determine the energy cost of treadmill exercise and maximum $\dot{V}O_2$ of chickens.

To determine the energy cost of treadmill exercise, birds were run for 10 minutes at different speeds and grades and $\dot{V}O_2$ measured at 5 and 10 minutes to establish that a steady-state had been attained. The O_2 uptake at steady-state ($\dot{V}O_2^{SS}$) was found to be a linear function of both speed and incline of the treadmill. For example, $\dot{V}O_2^{SS}$ while exercising on the level is:

$$\dot{V}O_2^{SS} = 18.5 + 1.069 V_H$$

where $\dot{V}O_2^{SS}$ is ml O_2 /min/kg body weight and V_H is horizontal treadmill speed in m/min. The slope of 1.069 ml O_2 /kg·m represents the inverse of efficiency when expressed in appropriate units for energy. Since 1 Kgm = .002343 kcal and .1 liter of O_2 = 4.825 kcal (at RQ = 0.82), then the slope is 2.201 kcal used per kcal of horizontal work done. Thus, the efficiency of horizontal locomotion is the reciprocal X 100 or 45.4%.

The O_2 cost ($\dot{V}O_2^{SS}$) for treadmill exercise at various grades (3 to 18°) and at 12.5 and 20 m/min horizontal speed (V_H) was determined for birds. The horizontal $\dot{V}O_2^{SS}$ was subtracted away for each $\dot{V}O_2^{SS}$ to obtain the O_2 cost relative to velocity of vertical velocity. The relation found was

$$\dot{V}O_2^{SS} = 0.7708 V_V$$

where $\dot{V}O_2^{SS}$ is net O_2 cost (ml/min/kg) and V_V is vertical velocity in m/min. The efficiency of vertical work was calculated as given above, using the slope of 0.7708 ml O_2 /kg·min and was found to be 63.0%. The gross O_2 cost is the sum of the horizontal and vertical costs and is given by:

$$\dot{V}O_2^{SS} = 18.50 + 1.07 V_H + 0.77 V_V$$

Maximum $\dot{V}O_2$ was determined in 5 birds using the EPT protocol. For each animal, max $\dot{V}O_2$ was attained at 40 m/min, zero grade, as was found for peak heart rate. Thus, it would appear that cardiac output, O_2 delivery and O_2 uptake attained maxima at the highest speed of 40 m/min of the EPT protocol and increasing the grade of the treadmill did not and could not increase these.

parameters further because maximum $\dot{V}O_2$ was reached. Max $\dot{V}O_2$ was 47.5 ± 2.6 ml O_2 /min/kg at 40 m/min, 0 grade. The O_2 cost at this exercise intensity is 61.26 ml/min/kg. Thus, for these 5 birds there was a mean O_2 deficit (energy cost - actual O_2) = 13.8 ml O_2 /min/kg which is 22.5% of the total cost. In other words, 23% of the energy transferred at 40 m/min involved anaerobic processes and by increasing the treadmill grade to 12° (21.3% grade) at min 21 of the EPT, the anaerobic cost increased further to $67.81 - 47.5 = 20.3$ ml O_2 /min/kg or 30% of the total cost. These results suggest that lactate production to sustain anaerobic energy transfer is substantial for the EPT protocol used. Yet [lac] in blood at exhaustion was only about 60% above resting. This finding is likely due to glycogen depletion and the subsequent limitation of lactate production. Exhaustion then would be due to an inability to sustain the anaerobic energy transfer rate via lactate production. This hypothesis will require studies of the time course for [lactate] in blood and muscle as well as muscle and liver glycogen depletion during exercise to exhaustion using the EPT protocol. Then, these variables need to be related to HSG tolerance to identify their possible association with this performance capacity.

4. Interrelationship between Endurance Performance and HSG Tolerance in Male Chickens P.A. Mole and R.G. Holly

A major objective of this research project is to determine if endurance exercise performance and +6G_z acceleration tolerance of chickens are related, and if so, to elucidate physiological traits responsible for each performance.

A total of 28 male SCHL chickens have been centrifuged at +6G_z to a bradycardia endpoint of 180 bpm. The mean \pm SE for acceleration tolerance (AT) was 18.8 ± 3.6 min. The distribution was skewed to the left with three distinct subpopulations with modes at 3, 24 and 58 minutes. Some 57% of the birds had AT < 15 minutes. A total of 9 birds have been accelerated twice one month apart in order to assess test-retest reliability of AT. AT₁ was 19.4 ± 6.7 and AT₂ was 19.0 ± 6.5 min. The test-retest correlation coefficient (r) was high and equal to 0.986. This finding indicates AT is highly reproducible using a bradycardia endpoint of 180 bpm. Measurements of Hct and blood [lactate] showed that acceleration stress did not increase [lac] but there was a marked efflux of plasma water from the vascular system with a resulting hemoconcentration of the formed elements of blood.

Analysis of the relationship between AT and RTE indicated the two performances were linearly related as given by

$$AT = 2.7 RTE - 48.9$$

for N=22, and the correlation was high and equal to 0.853. Thus, birds with high endurance capacity for treadmill exercise generally have a high acceleration tolerance.

Additional analysis were performed to help elucidate the bases for the relationship between AT and RTE. A possible covariate which could contribute to the relationship is body weight (BW). The r between AT and BW was $-.431$ ($p < .05$) whereas the r between RTE and BW was $-.293$ ($p < .05$). Multiple and partial correlation analysis showed that $R^2 = 0.762$ when AT was related to RTE and BW. The partial r^2 for the relation of AT and RTE, holding weight constant, was 0.708, whereas the partial r^2 for AT and BW, holding RTE constant, was 0.130. Thus, BW was not a covariate contributing to the high correlation between AT and RTE. Other factors must be involved.

Twenty two birds were subdivided into a low acceleration tolerance group (LAT, N=13) and high acceleration tolerance group (HAT, N=9) in an attempt to characterize possible differences responsible for HSG tolerance. Both groups had similar body weights ($2.17 \pm .09$ kg for LAT group and 2.00 ± 0.09 kg for HAT group) but they differed in AT (7.2 ± 1.0 min versus 37.1 ± 5.8 min) and in RTE (20.8 ± 1.3 min versus 31.9 ± 2.6 min) for LAT and HAT groups, respectively. So animals grouped according to AT also differed in their endurance performance capacity on the treadmill.

Comparing the two group's responses to the EPT showed no significant differences for end heart rate (410 ± 7 bpm versus 414 ± 8 bpm), and cloacal temperature ($42.8 \pm 0.08^\circ\text{C}$ versus $42.6 \pm 0.13^\circ\text{C}$) and Δ hematocrit ($-3.9\% \pm 1.3\%$ versus $-4.6 \pm 1.4\%$) of the LAT and HAT groups, respectively. However, the HAT group did have a higher end exercise blood lactate increase ($+1.3 \pm 0.7$ mM) than the LAT group ($+0.7 \pm 0.4$ mM). The meaning of this difference is not clear at present.

The groups also did not differ with respect to both % Hct and blood lactate changes during HSG stress. But the HAT group did respond with a higher initial rise in heart rate and this group also was able to sustain a higher heart rate throughout the acceleration period when compared to the LAT group. Presumably the HAT group was able to maintain a "more adequate" circulation during the HSG stress, but the reason for this ability is not obvious at this time. The greater lactate and heart rate changes could reflect, at least in part, a greater catecholamine titre for the HAT group.

The heart and portions of red and white leg muscle (gastrocnemius) were homogenized and used to determine the capacity of the respiratory chain to oxidize succinate (succ Q_{O_2}) and the capacity of the TCA cycle to oxidize pyruvate (pyr Q_{O_2}) in these birds with low and high AT. There were no significant differences in succ and pyr Q_{O_2} of heart and white gastrocnemius muscles of the LAT and HAT groups. However, the LAT group had a significantly higher succ and pyr Q_{O_2} for red gastrocnemius muscle (e.g., succ Q_{O_2} was 104 ± 13 versus $64 \pm 14 \mu\text{l O}_2/\text{min/gm}$ muscle and pyr Q_{O_2} was 67 ± 12 versus $48 \pm 10 \mu\text{l O}_2/\text{min/g}$ when LAT muscles were compared to those of HAT group). Generally, a high oxidative capacity of a muscle is associated with a greater capillary density so this difference in Q_{O_2} could mean that the LAT group had a higher perfusion of their red muscles. This could have minimized their ability to maintain perfusion pressure and flow to leg muscles, thereby limiting acceleration tolerance. However, this speculation requires detailed study for confirmation.

Studies are planned to evaluate the relationships between AT, RTE, max \dot{V}_{O_2} , max cardiac output, stroke volume, and total peripheral resistance of low and high HSG tolerance birds.

The relationship between AT and RTE appears to have a physiological bases since repeated weekly bouts of exhausting exercise markedly increased RTE and this adaptation was associated with a significant increase in AT of these birds. For example, for a total of 17 birds, $\% \Delta$ AT was related to $\% \Delta$ RTE (due to exercise training) by the following linear relationship: $\% \Delta$ AT = $56.7 + 3.3 (\% \Delta$ RTE). The correlation coefficient (r) was 0.60. These findings thus suggest that as RTE increases so does AT. Some common adaptive mechanism must be involved in these two performances.

5. The Debilitating Effects of +6G_z Acceleration Stress in Male Chickens
P.A. Moló, R.G. Holly, T.J. Barstow, and B. Anderson

An important question addressed by the research undertaken during the last 1½ years is whether acute acceleration stress produces any lasting impairments of whole body performance and physiological functions.

Preliminary data have been obtained along several lines. First, birds were rated immediately after centrifugation with respect to impairment related to ability to maintain normal posture. Scores ranging from 1 (no apparent debilitation) to 5 (moribund) were given to each bird after being accelerated to 180 bpm bradycardia endpoint. Birds with low tolerance (7.2 ± 1.0 min) had a significantly lower score (2.1 ± 0.2) as compared to that of 3.6 ± 0.2 for birds with high tolerance (37.1 ± 5.8 min). Thus, the longer the exposure to acceleration stress, the more postural debilitation was induced in the birds.

Performance debilitation was also assessed by running birds to exhaustion (to determine the effects of acceleration on RTE) on the day following +6G_z acceleration to 180 bpm bradycardia endpoint. The test-retest for RTE indicated that a difference in RTE of ± 3 min would be significant at $P = 0.025$. Of the 17 birds tested so far, 7 or 41% (Group A) had a marked reduction in RTE = $17.4\% \pm 3.0\%$. The remaining 59% (Group B) had an increase in RTE = $24.9 \pm 3.5\%$. Thus, acceleration stress either depressed or enhanced endurance performance 24 hours after centrifugation. The physiological bases for this dichotomy is not presently known. T_c, heart rate, Hct and blood lactate response to exercise on the day following acceleration were not different from the pre-acceleration control RTE responses. Also, the few measurements on succ and pyr oxidative capacities of heart and leg muscles of control and accelerated birds showed no obvious differences. Likewise, preliminary studies on the effects of acceleration stress on cathepsin D enzyme activity of these tissues also have not demonstrated any enhancement of lysosomal proteolytic activity which could impair muscle function. So we do not know whether there is a metabolic, circulatory or central nervous system alteration responsible for the debilitation or enhancement of endurance induced by acceleration stress.

Additional studies were undertaken to determine the time-course of the RTE debilitation induced by one acceleration exposure. Within 7 days acceleration, RTE had returned to the pre-acceleration control for Group A. In contrast, RTE for Group B increased further by day 7 and was maintained at the 7 day level through day 28. Birds that were not accelerated were also run to exhaustion on a weekly basis in order to assess whether repeated exhausting exercise would also enhance RTE. RTE for this group (C) did not change until the 5th run, in contrast to group B where RTE increased significantly by the 3rd run. Thus, these data show, first, that acceleration stress depresses RTE for some birds (41%) and that this lasts for about 7 days. But these animals are not able to improve RTE by repeated exhausting bouts of exercise. Acceleration significantly enhanced RTE in 59% of the birds within one day and this effect lasts for at least 28 days. The reasons for these changes in endurance performance are not known at present.

Summary

1. Endurance capacity and +6G_z acceleration tolerance are highly related performances in SCWL male chickens.

SUBSECTION III-D

1. COMPARISON OF THERMOREGULATORY MECHANISMS IN TRAINED MALE AND FEMALE DISTANCE RUNNERS DURING EXERCISE IN HOT-DRY HEAT. W.C. Adams and Linda Paumer, Department of Physical Education, University of California, Davis, CA 95616

It has been demonstrated in previous studies that women have lower sweat rate than men, although some authors maintain that women are more efficient thermoregulators since they maintain core temperature at the same relative workload without large fluid losses. In the present investigation, the thermoregulatory mechanisms of men and women were studied in well trained and heat acclimated distance runners (6 men, 6 women). Each exercised on a level treadmill for 75 minutes at workloads equivalent to 30% and 70%. $\dot{V}O_{2max}$ in both with neutral ($T_a = 23^\circ\text{C}$, $RH = 45\%$) and with hot-dry ($T_a = 40^\circ\text{C}$ during 30% workload, 35°C during 70% workload, $RH = 35\%$) environment. There were no significant differences in core temperature response. Partitional heat exchange showed the males to have higher levels of metabolic heat production (due to exercising at greater absolute workloads) and thus, higher levels of evaporative heat loss. In the hot-dry protocols, the latter was partially due to an increased loss of sensible heat dissipation capacity. Both sexes demonstrated an overproduction of non-evaporated sweat, although the women appeared to have a somewhat higher evaporative efficiency, which could be primarily attributed to a lower skin wetted-ness. There were no differences between the males and females in BV/kg or PV/kg . While the females had higher heart rates than the males in all conditions, both sexes demonstrated similar increases in heart rate during the heat exposures. Blood parameters revealed that the men experienced a greater hemoconcentration during the runs and a lesser hemodilution during the walks than the women, which was shown to be a reflection of their greater sweat rate. There were no significant differences between the sexes for changes in protein concentration, total protein, electrolytes, or osmolarity. It was concluded that well trained and heat acclimated women appear equally capable as men of similar capacity to handle thermal stress at higher work rates, and that the mechanisms of thermoregulation are essentially similar for both sexes.

2. BLOOD VOLUME IN YOUNG MEN AND WOMEN: RELATION TO BODY COMPOSITION AND AEROBIC CAPACITY W. C. Adams

Blood volume (BV) and its components, as affected by body composition and aerobic fitness, were studied in a group of 60 men and women, ages 17-29. Subjects were assigned to one of six groups (N=10) according to sex and physical training level (nontrained; trained; or highly trained, competitive middle-distance runners). Blood volume was determined by carbon monoxide (C) inhalation, body composition by hydrostatic weighing, and maximal oxygen uptake ($\dot{V}O_{2max}$) by a continuous multistage treadmill running protocol. As expected, there were significant sex differences in hemoglobin concentration [Hb] and hematocrit (Hct). Associated with their lower [Hb] and Hct, the females had lower red cell volume (CV) and total hemoglobin content (Hb_T) per kg of body weight (BW), but their BV and plasma volume (PV) was not significantly different from male groups of equivalent training level. A clear training level effect was equally evidenced in both sexes, with the competitive runners having the lowest body fat, and per kg BW, the highest BV, PV, CV, Hb_T and $\dot{V}O_{2max}$. Regression analysis showed that Hb_T was the single blood parameter most closely related to $\dot{V}O_{2max}$ ($r=0.85$), with no significant difference between the sexes. However, the combined male and female competitive runners sample ($r=0.96$) demonstrated a significantly higher $\dot{V}O_{2max}$ to Hb_T ratio than the nontrained males and females. Thus, at equivalent training levels, the females' lower $\dot{V}O_{2max}$ was associated with a lower Hb_T which can be attributed to a lower [Hb], rather than to a lower cardiac output and/or oxygen extraction at the muscle level.

3. THERMOREGULATORY RESPONSES OF HIGHLY TRAINED MEN AND WOMEN DURING EXERCISE
IN NEUTRAL AND WARM-HUMID CONDITIONS

N. Daly and W.C. Adams

Six highly trained men and six highly trained women, who had previously undergone a rigorous heat acclimation routine, walked at 30% maximal oxygen uptake ($\dot{V}O_{2\max}$) and ran at 70% $\dot{V}O_{2\max}$ in two ambient conditions: 1) neutral ($23^{\circ}\text{C } T_{\text{db}}$, 45% RH) and warm-humid ($30^{\circ}\text{C } T_{\text{db}}$, 85% RH). There was no significant difference between the sexes in rectal temperature or mean skin temperature. There was no significant difference between the sexes in $\dot{V}O_2$ expressed as percent of $\dot{V}O_{2\max}$ with time or between environmental conditions. Heart rate was consistently higher for the women, but increased at the same rate in both sexes throughout the runs in both conditions. The male's higher sweat rate (SR) could be accounted for by differences in absolute metabolic heat production and, by greater loss in sensible heat dissipation capacity and greater skin wettedness in the warm-humid condition. Neither sex appeared to shift plasma proteins, suggesting that SR may be the primary determinant of the magnitude and direction of plasma fluid shifts. It appeared that above a certain SR, as in the runs, plasma volume (PV) loss due to SR overcame the osmotic drive for water retention created by increasing plasma electrolyte concentrations causing a hemoconcentration in both sexes. Conversely, both sexes evidenced a hemodilution in the walks, possibly due to the weak SR drive for water loss being overcome by the strong osmotic forces. In the neutral conditions both sexes were working at the same relative SR, resulting in PV shifts of similar magnitude and duration at both workloads. The men's relatively greater SR increase in the humid condition, particularly at the 70% $\dot{V}O_{2\max}$ workloads, was associated with a greater hemoconcentration. This study suggests that these highly trained, heat acclimated men and women thermoregulated equally well, with an essentially similar pattern of physiological response.

SUBSECTION III-E

1. INFRARED THERMOVISION: AN EASY METHOD OF MONITORING BODY SURFACE TEMPERATURES AND UNDERLYING PERIPHERAL VASOMOTOR SHIFTS

Sustained static and dynamic muscular contractions depend upon an adequate blood flow to the exercising limb to supply oxygen and remove metabolites and heat. Changes in body heat, particularly surface heat, expressed as skin temperatures T_s and measured by thermistors placed at numerous discrete sites have been routinely determined by physiologists. This method is open to question, particularly with reference to sub-regional skin temperature variation. On the other hand, infrared (IR) radiography has the advantage of visualizing the temperature pattern over a wide surface region of the body. Presently, only limited IR determinations have been made during exercise and then only on subjects running.

In the present investigation, an AGA 680 thermovision system, which presented a 10-colored isothermal display on a color slave monitor, in combination with a Bolex 16 mm movie camera, was used to take real time IR movies at 16 frames per sec. of two trained athletes before, during, and following static forearm gripping, dynamic one-legged ergometric and running exercise. The purpose of this experiment was to estimate the underlying peripheral vasomotor shifts reflected by changes in skin surface temperatures accompanying these bouts in addition to sub-regional surface temperatures.

Surface temperatures over statically contracting muscles varied with the percent of maximal gripping applied. A progressive increase in T_s was observed from static gripping of 20%, and 50% for 5-min., through 80% for 1-min. The greatest rise in T_s was observed over the anterior portion of the palmaris longus and flexor pollicis muscles 1.5 to 1.7°C, respectively, following the 80% grip bout. The IR thermovision taken during 5-min. bouts of dynamic one-legged exercise showed that the T_s over the regions of the exercising leg (rectus femoris and tibialis anterior) was warmer than the contralateral non-exercising leg. Both limbs manifested a drop in the T_{sk} (1.5 to 4.5%) with exercise suggesting a sympathetic mediated vasoconstriction. The response time of these ΔT_s is much faster than conventional thermistors. Comparative measurements between thermistors and IR thermographs were made during the running exercise.

In the present study, the IR thermovision system appears to have significant advantages over the thermistor reflecting transient surface temperature changes corresponding to the on-off of exercise states and the peripheral skin blood flow changes induced by a variety of exercise modes.

2. COMBINED EFFECTS OF BREATHING RESISTANCE AND HYPEROXIA ON AEROBIC WORK TOLERANCE

Effects of three curvilinear inspiratory resistance (R_1 , R_2 , R_3) on the cardiorespiratory responses of seven well-trained men during incremental cycling tests to exhaustion were studied by comparison to the low resistance, R_0 (at 1 s/l, $R_0 = 0.2$; $R_3 = 6.5$ cmH₂O·s/l). Submaximal $\dot{V}O_2$ and the gas exchange anaerobic threshold (AT) were not affected by increasing resistance. Although maximal work rates were not significantly changed, highly significant reductions were observed for \dot{V}_E ($R_0 = 166.3$; $R_3 = 99.7$ l/min BTPS), $\dot{V}O_{2\max}$ ($R_0 = 4.26$; $R_3 = 3.74$ l/min), HR ($R_0 = 185$; $R_3 = 176$ beats/min), and endurance ($R_0 = 17.3$; $R_3 = 15.5$ min) suggesting that aerobic work tolerance was dependent on ventilatory capacity. In additional tests removal of R_3 at exhaustion abruptly increased \dot{V}_E and $\dot{V}O_2$, and permitted work to continue. Ventilation and work tolerance were therefore limited by R_3 before the legs fatigued. Breathing 35% O_2 against R_3 produced significant, although small, increases in AT, $\dot{V}O_{2\max}$, peak HR, and endurance while decreasing the hyperventilatory response to work above AT. Thus, aerobic work tolerance reduced with high inspiratory resistance was partly restored by moderate hyperoxia, apparently because the ventilatory limit was delayed.

IV.

SUMMARY OF COMPLETED STUDIES: 1978 - 1983

A. GENERAL AIMS

Pilots flying high performance aircraft appear to suffer from G fatigue and the Air Force is ostensibly interested in finding ways to attenuate this accumulative fatigue condition.

Individuals exposed to the High-G environment must perform an M-1/L-1 straining maneuver in order to resist the debilitating effects of +G_z. Since the M-1/L-1 is a very physical activity, it can be very fatiguing by itself and may well be a major contributing factor to the sensed and expressed fatigue experienced by pilots.

The broad physiological effects of acceleration are generally known with respect to relaxed G-tolerance modalities. By contrast, less is known about the physiological responses and limitations which occur with acutely repetitive, high levels of acceleration and of the physiological basis of methods used to alter acceleration tolerance.

Over approximately the last 20 years, the role of physical conditioning and the state of fitness on G-tolerance have been investigated. Physical training appears to have less effect on relaxed G-tolerance however, straining G-tolerance which has a direct application to fighter pilots may be improved by specific modalities of physical training. With this in mind a number of studies were designed to investigate the role of anthropometric characteristics, general physical fitness and specific modalities of physical training on orthostatic tolerance with a specific emphasis on G-tolerance and G-induced fatigue.

The summary which follows and the various working manuscripts attached are the results of 5 years of investigations related to this general question.

The initial investigation addressed the question of the physical demands of the M-1/L-1 maneuver per se. A series of experiments were conducted incorporating graded straining efforts - 35, 55, and 75% of 1-RM voluntary muscular contraction while monitoring metabolic and cardiovascular responses. These results are presented in Abstract 3 and working Manuscripts 1 and 2.

B. Investigations of Man: Orthostatic Tolerance Related to Physical Characteristics and Specificity of Exercise Training with Primary Observations of Underlying Physiology

B-1. The Effects of Body Somatotype and Training Modalities on Orthostatic Tolerance

Our first study investigated the relationship between body build, general fitness and orthostatic tolerance (OT). Documented literature implied but did not state explicitly that physical training effected OT. We selected a small group of subjects for detailed study from a larger initial sample based upon their tilt tolerance. The sample was selected based upon the single criteria fainter vs. non-fainter. Having identified individuals who fainted or did not faint upon a series of independent 70° head-up tilts, a comprehensive test battery of anthropometric and physiologic functional measurements were made to characterize each group. It was anticipated that these arrays of test items would provide a valid OT-screening test battery.

The results are summarized in Abstract B-1. None of the anthropometric test items distinguished fainters from non-fainters, however, the non-fainters are generally stockier and fatter than the fainters; the eye to heart distance was the single best relationship with OT but it was not significant. The physiological results produced a number of significant differences between the two groups; 1) The fainters had a higher $\dot{V}O_2$ max and endurance performance capacity and a less of a reduction in end SV and Q. 2) The non-fainters maintained a higher HR, \bar{P}_a and TPR. Later studies support these general findings and have added detail to these initial observations.

B-2. The Effect of Physical Conditioning on +G_z Tolerance

The comprehensive results of this study are contained in Wm. Epperson, Ph.D. Dissertation, UCD, 1978 and reported in (Aviat. Space & Environ. Med. 53(11), 1982). This study represents the first direct evidence of a study designed to examine the relationship between the changes induced by physical conditioning on acceleration tolerance as simulated by aerial combat maneuvers (SACM). Three groups of Lockland AFB volunteers who had finished their Class II Flying Physical Examination served as subjects.

The results of a 12-week training program clearly favored the weight trained (W) over the runners (R) in their acceleration tolerance; no significant change was recorded for the control group (C). The average SACM increased 4 sec/week for the R and C groups while that for the W increased 15 sec/week. These differences were statistically significant at the $p < 0.05$. Specific aspects of the weight training program revealed significant relationships between sit-ups, arm curl improvement and SACM tolerance times. It appears that weight training will improve one's tolerance to repeated prolonged exposure to high +G_z loads.

B-3. Physiological Response to the L-1 Straining Maneuver at One Gravity

The purpose of this study was to evaluate the energy cost of performing the straining maneuver per se and the associated cardiovascular responses. Subjects were placed in a mock-up pilot seat and asked to perform a straining

maneuver for 5-minutes or until voluntary fatigue at 35, 55 and 75% of 1R-Max volitional strength of their leg extensors.

The results are reported in Abstract B-3 and in detail in B-1 of the attached working manuscripts. Because of the nature of this straining effort, respiratory gas exchange is intermittent. Further, the oxygen intake during the straining maneuver is raised only 4-fold over resting but reaches 80% of $\dot{V}O_2$ max in the first minute following the straining effort. This indicates a measureable anaerobiosis which averaged about 25% of the total energy required during the 35 and 55% straining efforts (SE). However, during the 75% SE, the metabolic components were reversed being approximately 26% aerobic and 76% anaerobic. Thus under demanding SACM-SE, the muscular effort is dependent upon anaerobic energy exchange. This capacity is enhanced by strength conditioning associated with weight training. Supportive evidence is provided by the blood levels of lactate and $\dot{V}CO_2$ following the SE.

The stress of this effort is apparent by the immediate although modest rise (2 to 3 times resting) in nor-epi following the SE; this is comparable to data reported for ACSM and practice missions. The cardiac dynamics reveal a very rapid rise in HR and SBP with the onset of the SE; greater SE is rank related to the degree rise in both variables, doubling at 75% SE. In general, the SV and Q fall off beyond two minutes of this effort, thus the increase in HR does not compensate for the drop in SV. There is an immediate fall in HR and Q but SV remains elevated, possibly due to the elevated nor-epi following the SE. A general advantage to tolerate this SE effort was observed in those individuals who had greater abdominal strength and respiratory forced pressure.

B-4. Changes in Orthostatic Tolerance and Related Physical and Functional Characteristics with Cross Training

The purpose of this study was to continue with characterization of the anthropometric and functional responses and to investigate the effects of cross-training of individuals who were classified as predominately endurance trained as opposed to non endurance trained. The results are presented in Abstract B-4 and in detail in the working manuscripts B-2 & 4.

Generally, significant differences between the two groups are seen in higher body weight and fat, and lower lean body weight in the non-fainters. Fainters have a higher $\dot{V}O_2$ max but a very interesting pattern was discovered between tilt tolerance and physical conditioning; of 16 individuals tested, the ratio of fainters to non-fainters increased with the volume of running engaged in miles per week.

The cardiovascular responses are significantly different between the two groups with respect to the regulation of their TPR. Non-fainters were able to increase their MAP in the face of a falling Q. The rate of pooling is greater in the fainters although there is no difference in the end tilt levels between the groups. Finally, the nor-epi levels are significantly higher in the non-fainters following tilt.

Preliminary studies conducted on six subjects over a period of 12-weeks cross training showed a significant gain in the OT-tilt in endurance conditioned individuals engaged in weight training regimen; conversely no change was observed in the strength conditioned engaged in endurance training.

B-5. Blood Resistivity Changes Associated with Orthostatic Stress:
Electrical Impedance Output Implications

This information is contained in Abstract B-5 and summarized in section IV, E-4.

B-6. Distinguishing Anthropometric and Physiological Characteristics of Fainters and Non-Fainters: Application of Two Differing Tilt Formats and Determination of Optimal Time Dichotomies

This information is contained in the working manuscript B-5 attached and summarized in section IV, E-1. The comprehensive data are reported in J. Graham's M.S. Thesis, UCD, 1980.

B-7. Comparison of Plasma Shifts and Electrolyte Data in Progressive Stepped Tilt vs. Fixed-Angle Tilt

This information is contained in Abstract B-6 & 7 Section III and in a detailed report under Section V, #1. It represents work completed in the past year.

B-8. Physiological and Hormonal Response to Cross Training in Well Conditioned Young Men

This information is contained in a progress report in Section V, #2. It represents on going work and focuses on the underlying neural-endocrine control of the specific modalities of training.

B-9. Summary

A series of studies were planned to investigate the contribution of physical status conditioning to orthostatic tolerance both active and passive. Efforts to establish a valid test battery to pre-screen individuals by measuring selected anthropometric and functional responses to OT-tilt have yielded significant results. Subsequent investigative efforts to understand the role of physical training have generated a number of practical applications and important theoretical insights. Continuing studies are further elucidating the underlying physiological control mechanisms responsive to physical training. Several significant non-invasive technical applications were developed and validated. The information acquired has been reported in the journal literature and as free communication at professional national meetings e.g., American College of Sports Medicine, Federation Proceedings and at the national meeting of Aviation Space and Environmental Medicine. Presently nine manuscripts are planned or in progress. Three Ph.D. degrees and five Masters degrees have been awarded as a direct consequence of this funding by the AFOSR of this research.

C. THE EFFECTS OF ACUTE AND SUSTAINED HIGH GRAVITY (+G) ACCELERATION ON THE HEART AND SKELETAL MUSCLES IN THE CHICKEN

One of no less recognized scholars than Aristotle once exclaimed that biologically, man was a featherless biped. The biological stresses associated with acceleration tolerance require an appropriate animal model - a biped - to study the underlying physiological mechanisms supporting the biological systems during high sustained gravity (HSG). A chicken meets many of the prerequisite criteria needed for the invasive studies planned. Equally important was the fact that A. Smith (Smith and Burton, Physiologist 23:suppl., 1980) have generated a physiological baseline reference for these animals and further had developed a genetic line of chickens that possessed extraordinary exercise fitness and acceleration tolerance. Consequently, the chicken and more particularly a specific genetic line of chickens were available for study.

Several studies were completed (See Abstracts B-1,2,3,4,&5). An exercise test was developed to assess the $\dot{V}O_2$ max uptake and endurance capacity of the chickens while exercising on a motor driven treadmill. A multistage protocol which combined incremental changes in speed and grade was developed based on the endurance performance of 28 male white leghorn chickens from A.H. Smith stock. The criteria used to assess endurance performance was run time to exhaustion (RTE). Repeated tests verified that the test was highly repeatable $r = 0.933$ with a $p < 0.005$ (See Abstract 1).

The second study (See Abstract 2) applied the above criteria to characterize the physiological and metabolic responses of chickens during exercise to exhaustion. Since techniques had not been developed to directly measure the respiratory gas exchange of chickens during exercise, initial studies relied on cloacal temperature, heart rate, lactate and hematocrit. Heart rate was found to peak at 40 m/min speed at zero grade. It was interpreted as reflecting a maximum attained by cardiac output and O_2 delivery; neither cloacal temperature nor heart rate however, appeared to be the limiting factor in the RTE. Subsequent experiments employed techniques to directly measure the respiratory gas exchange and thus calculate the $\dot{V}O_2$ uptake and energy exchange. These measurements corresponded with prior observation of maximal speed - 40 m/min at zero grade - thus $\dot{V}O_2$ delivery, uptake cardiac output occur in sink with this physical effort. Interestingly, the contribution of aerobic/anaerobic energy is approximately 75%/25% of the EPT. This is roughly the break down of the energy components recorded during the static effort generated in man performing the L-1 straining maneuver. Mole' suggests that these results indicate that lactate production to sustain anaerobic energy transfer is substantial, given the EPT protocol used.

A third study assessed the relationship between the acceleration tolerance (AT) of the chicken and their RTE. Three subpopulations were identified based on the AT. Test-retest reliability, separated by one month, showed a very high reliability $r = 0.98$ when using a bradycardia endpoint of HR at 180 bpm. A significant difference between the AT groups was also found for their RTE; the high AT group, HAT had a significantly higher RTE than the lowest AT group, LAT. No significant differences, however, were observed in cloacal temperature, heart rate or Hct between the two groups. Lactate did differ between the two groups although the meaning of this difference is not evident at this time. It is suggested that the HAT group was able to maintain a more adequate circulation during the HSG stress but no clear physiological reason

can be given for this advantage presently; it may be that the HAT greater lactate and heart rate changes reflect a greater catecholamine titer. This hypothesis is in agreement with observations made on man during 70° head-up tilt tolerance. Individuals with high orthostatic tolerance (non-fainters) were found to have higher catecholamine levels following tilt; however, these individuals were not the high endurance trained individuals as seen in the chicken model. Again, it was observed in man (Abstract A-4) that it is not endurance performance as measured by $\dot{V}O_2$ max but rather the volume of endurance activity engaged in each week which separated the fainters from the non-fainters.

The relationship between AT and RTE appears to have a physiological basis since repeated weekly bouts of exhausting exercise markedly increased RTE and this adaptation was associated with a significant increase in AT of these birds. Some common adaptative mechanism may well be involved in these two performances.

The fifth study on chickens addressed the documented observations of the debilitating effects of acceleration stress. A single +G_z acceleration to bradycardia endpoint produced a moderate incidence of lesions including subendocardial hemorrhaging in hearts of adult male chickens. It was not clear whether heart lesions alter cardiac performance and functional capacity; and whether the dysfunction is transient or chronic although subsequent documented work on miniature swine suggest it is transient.

A final study (Abstract B-6) conducted on chickens focused on the changes in the histochemical and biochemical metabolic characteristics of the skeletal muscles following acceleration and endurance training. In summary, an increase in lactate was found, however in the lower AT group. Further it was observed that low tolerance - low endurance birds have a lower aerobic capacity. This is consistent with the increased lactate production. Inconsistent however, is the finding based on the oxidative capacity of red and white fibers taken from the gastrocnemius muscle of HAT and LAT birds. That is the low tolerant birds, AT were found to have a much higher aerobic capacity in the red gastrocnemius - succinate QO_2 ; the white portions were similar. This latter finding is consistent with human studies in our laboratory (Abstract A-4). The physiological scenario runs something like this; a high volume of running is dependent upon aerobic metabolism, this is reflected in the bird studies by increased oxidative capacity of red fibers, this metabolic state is associated with increased density of capillaries to these fibers which results in a reduced resistance to flow and finally to a greater rate of plasma efflux and peripheral pooling as noted in the fainters who have high endurance tolerance. Finally, a significant independent study resulted as a spin off to these questions. It is attached as a manuscript, part of the dissertation work of Robert Holly. It develops physiological evidence for the specificity of a stretch model as optimal to the changes observed in trained skeletal muscle.

D. AMBIENT HEAT STRESS AND PHYSICAL PERFORMANCE

Given the fact that pilots of high performance air craft experience fatigue attributable to the demands of the high-G environment, it seemed important to address the problems of heat stress. Physiologically tolerable heat stress is experienced by pilots especially in hot climates and it is established that this has an adverse impact on physical performance. Nunneley

(Aviat. Space & Environ. Med. 49:(6), 1978) has conducted investigations to determine the effects of thermal conditions similar to those occurring in the aircraft cockpits in warm climates when high temperature and radiant heat play important roles both on the ground and in flight.

The thrust of our investigations were to focus on the role of physical fitness and exercise on the thermoregulatory response. In addition an effort was made to determine the physiological responses of the male vs. the female with respect to thermoregulation and to further determine if these exert significant differences in tolerance, response or adaptation through physical training between the sexes (See Abstracts C-1,2,&3).

One of the principal findings of the present series of studies that relates to the focus of investigations conducted by Nunneley is that body size effects the amount of sweating to thermoregulate. With equivalent Tsk, the larger individual would be expected to have a reduced heat dissipative capacity via insensible avenues (convection and radiation) in the heat than would a smaller person, thus requiring additional sweating to thermoregulate effectively. Therefore both body size and physical conditioning - heat acclimatization levels need to be considered when estimating thermoregulatory responses for design or performance purposes. Particularly, one must account for the Tre and SR response to anticipated heat conditions and especially with respect to the differences between the sexes.

Nunneley (Op. cit.) found that weight losses of 1.2% in simulated cockpit conditions were comparable to those recorded following fighter missions for 90-minute sorties in the F-4 and 1.5% for 60-minute Harrier flights. She further noted that although HR, and Tsk rapidly returned to baseline following the heat stress, Tre was much slower and did not reach normal for 1 hour post flight. Recovery from heat stress is an important problem because of the multiple flights required of aircrew men under normal circumstances. The relative slowness of core cooling and failure to replace fluids, even under ideal circumstances are significant. Heat storage and dehydration can effect both performance and tolerance of other stresses, such as acceleration or hypoxia and be a major factor contributing to the sensation of fatigue.

Adams, Daley and Paumer (Abstracts C-1,2,&3) present evidence for the dependency of thermoregulation particularly the response of core temperature and sweat rate as related to body size (male vs. female differences) and physical conditioning. Given the entrance of women into the Air Force Academy and the acknowledged interaction of thermoregulation-dehydration on both acceleration performance under hypoxic states, the melding of these two independent but related studies may well produce guidelines for future selection and/or training procedures.

Aircrew normally experience high heat load on the upper body and head temperatures as high as 43°C have been recorded (Nunneley et. al., Aviat. Space & Environ. Med. 48:1977). The result is a significant increase in subjective fatigue. The authors also note a paradoxical decrease in leg temperature attributed to an increase in the sweat rate. In flight, this head to foot disparity is often amplified by air conditioning systems aimed primarily at the lower body.

One of our collaborators Col. Veghte AMPL, Wright-Patterson Air Force

Base cooperated in a series of studies utilizing IR-thermographic scanning techniques to assess rapid transient changes in surface temperature during selected physical performances. Acute $+G_z$ acceleration studies suggest that the prior state of hydration, particularly as it relates to plasma volume, blood electrolytes and vascular resistance may significantly effect acceleration tolerance. Since physical training has been shown to increase blood volume (plasma volume), it was hypothesized that the response to heat stress would be more efficient in aerobically trained individuals. Transient changes in skin temperatures were observed with progressive increments of static gripping. These transient changes recorded using the AGA 680 Thermovision system provided specific information as to onset of change, and surface temperatures over specific muscles. The transient heat changes and subjective feelings of comfort or fatigue give promise to develop a strategy for establishing criteria for quantifying thermal stress and accumulative fatigue (See Abstract D-1).

E. Development of experimental Protocols and Procedures

E-1. Tilt Protocols

Since the emphasis in this project focused on gravitational stress, it was incumbent on us that a valid and reliable method of measuring orthostatic tolerance be established. Documented protocols included tilt, lower body negative pressure and centrifugation. Given the limitation of facility and resources, we selected the tilt modality. Developing requirements of our research, particularly the need to measure transient physiological changes and to establish reproducible criteria for orthostatic tolerance led us to review and to reexamine the tilt protocol. The results of this investigative effort are contained in John Graham's Masters thesis (The CV-Response to Orthostasis in Men: Variations in Orthostatic Tolerance, UCD, 1980).

A graded tilt protocol was investigated as a method of monitoring physiological changes associated with orthostasis and to validly assign individuals into tolerant or non tolerant categories for screening or training purposes. The application of a dose response tilt protocol tended to slow down the cardiovascular response and allowed comparison of different degrees of the normal state of upright man. The protocol did not appear to be time dependent but one of degree. Significant differences were observed for many of the physiological variables for tilt angles 10 through 60, however no significant change was noted beyond 60° tilt. The optimal time to differentiate low from high OT during the fixed 70° head-up tilt was 20 minutes. The variables most predictive of the tolerant vs. the less tolerant are an increase in heart rate, blood pressure, and peripheral (PR) resistance and a decrease in cardiac output. The subjects response to incremental tilt is an increase in PR at low angles while cardiac effector mechanisms predominate at higher angles. No single protocol - fixed or incremental tilt - can be exclusively recommended to assess OT at this time.

E-2. Cardiac Output

Special effort was devoted to the validation of noninvasive measurements of stroke volume and the calculation of cardiac output. The importance of this physiological parameter is apparent given the focus of the investigative studies during the five year contract period. Two noninvasive methods were applied viz., impedance rheography and the CO₂ rebreathing method, a variation of the procedures described by Farhi - estimate of equilibrium point (Farhi, et. al. Resp. Physiol. 28:1976), and Jones, et. al. (Clinical Exercise Testing, W.B. Saunders, 1975) - establishment of an equilibrium point.

The impedance procedure was validated against the conventional green dye technique (IDC) at rest while supine, sitting and standing, and during exercise loads of 25, 45 and 70% of VO₂ max. Correlation coefficients between the impedance and the green dye methods for stroke volume were 0.81 and 0.90 for the various postures and the exercise loads respectively. The mean values were consistently lower for the impedance method when compared to the green dye averaging 25.8 ml lower for the impedance. An observation of fundamental importance was that the repeat measurement variation for the two SV procedures was greater for the green dye method; although variable ranging from 2 to 21 ml, the variability for the green dye method was double that of the impedance procedure on the average.

E-4. Blood Resistivity

Since the impedance procedure is affected by the specific resistance of the blood, a series of experiments was conducted to determine the contribution of this factor to the measured factors. Temperature, and calculation of a form factor - general shape of the blood cell - were measured in mixed blood of varying dilution and blood of different HCT concentration obtained following varying intensities of exercise. The calculated resistance (P-values) of these blood samples was plotted against the measured values. A series of linear and quadratic prediction curves were run favoring the quadratic curve with a correlation of 0.99 between the blood resistance and the Hct. When this correction is made for the change in Hct resulting from peripheral pooling during tilt, then the calculation of SV by electrical impedance falls within 5% of the green dye method. This work has been prepared for publication and is contained in a working manuscript form B-3.

E-5. Impedance vs. Whitney Strain Guage for Determination of Blood Pooling

We are also using impedance for the measurement of blood pooling in the limb and felt it necessary to validate it against an accepted technique. In this regard, we have compared measurements of fluid pooling in the calf as measured with the Whitney strain guage and the impedance technique. Figure 3 of working manuscript B-3 by Mangseth attached shows the results from experiments on four individuals who were tilted for varying lengths of time. As indicated by the slope of the least squares line, the Whitney strain guage gives higher values for pooling as compared with the impedance method. Since it can be argued that neither method is absolute in its ability to measure tissue volume change, one should not place too much emphasis on this discrepancy. Of greater importance is the strong linear relationship between the two techniques. This tends to remove doubt as to what the impedance method measures and makes it a valid technique for estimation of blood pooling.

E-6. Echocardiography

A second method used to measure cardiac function non-invasively was the M-Mode echocardiograph. Changes in the diameter of the left ventricle (LV) were measured to estimate changes in the volume of the LV at the end of diastole and systole, from which parameters relating to cardiac function viz., stroke volume, cardiac output and ejection fraction. The procedures for measurement and calculations followed were those described by DeMaria, et. al (in Mason, Congestive Heart Failure, N.Y. York Med. Bks. p. 191, 1976). Good agreement was obtained between the echo and electrical impedance method; here the echo measurement generally produced higher stroke volume readings when compared with the corrected electrical impedance method. Correlations were significant and ranged in the 0.80 ± 0.05 . The echo method is vulnerable to somatotype - thick chested, mesomorphic body builds - and the gravitational effect on the orientation and conformation of the heart and lungs during tilt and lower body negative pressure. Because of these limitations consistent and valid measurements of cardiac function utilizing echocardiography is limited to a select group of subjects - lean ectomorphic individuals. As a result of this technical limitation a major objective proposed in the 1980-81 proposal viz., "Change in Left Ventricle in Response to Orthostatic Tilt" was not completed. Discussion with H. Sandler at NASA-Ames and Stanford where this procedure is performed routinely confirmed our experience with the limitation of the

echocardiograph procedure and confounded our stated objective to compare a wide range of individuals varying in body build and physical condition by selecting members of the football, basketball, wrestling, soccer and cross-country teams.

E-7. CO₂ Rebreathing Method

The final noninvasive method of assessing cardiac function was the application of the CO₂ rebreathing procedure. Modifying methods of L. Farhi (op. cit.) Daly and Paumer, two master students (see Abstracts D-1 & 2), applied the rebreathing method to measure cardiac output during work in the heat. Subsequently a third master student modified the method by Jones, et. al. (Schelegle, E. M.A., UCD, 1981 The Effects of Prolonged Exercise on Aerobic Capacity: A Cardiovascular Study) to achieve highly significant Q values.

Cardiac Output: Cardiac output was measured using a carbon dioxide rebreathing method. Measurements were made utilizing an automatic three-way breathing valve (see Figure E-1) which was in combination with the Daniels valve used in respiratory measurements. This allowed the experimenter to switch from a respiratory gas mode to a rebreathing mode without interrupting the normal breathing pattern of the subject. Records of respiratory movements were made by monitoring breath by breath changes in CO₂ at the mouth using a Beckmann LB-2 CO₂ analyzer and a single channel Hewlett-Packard 680M script chart. A five liter anesthesia bag was attached to the third outlet of the automatic mouthpiece. The anesthesia bag was filled with 3.5 liters of a 5% CO₂, 95% O₂ mixture, plus a variable amount of 100% CO₂. The volume of 100% CO₂ added to the anesthesia bag resulted in a CO₂ concentration slightly higher than the partial pressure of CO₂ in the subjects' mixed venous blood. This concentration was estimated by first estimating Q at a given workload by plugging $\dot{V}O_2$ into the regression equation of Q vs. $\dot{V}O_2$ obtained in pilot work. Using this estimated Q along with V_{CO_2} at that workload arterial-venous carbon dioxide difference $(A-V)_{CO_2\Delta}$ was calculated. $P_{\dot{V}CO_2}$ was then estimated using measured end tidal carbon dioxide concentration and the estimated $(A-V)_{CO_2\Delta}$.

Prior to each rebreathing maneuver the subject was instructed to breath to the beat of a metronome set at a rate slightly higher than the normal respiratory frequency for that workload and subject. Once the subjects breathing patterns were synchronous with the beat of the metronome the experimenter counted down three breaths. On the third breath the subject was instructed to signal the experimenter at the time of an expiration by slapping their thigh. With this auditory signal the experimenter switched the automatic three-way valve to the rebreathing mode for a period of nine to ten breaths. During this maneuver, gas was continuously drawn into the head of the LB-2 carbon dioxide analyzer. The analyzer output was recorded on a script chart allowing the breath-by-breath analysis of P_{CO_2} at the mouth.

Cardiac output was calculated by the method described by Jones et. al. (40) and others (17,18). Blood carbon dioxide partial pressures were converted to blood content using the quadratic equation derived by Miyamura (44), to describe carbon dioxide dissociation in exercising subjects. Arterial CO₂ partial pressure was obtained from blood gas samples taken prior to the rebreathing maneuvers. Measurement of blood gases were made on a Corning 65 blood gas analyzer.

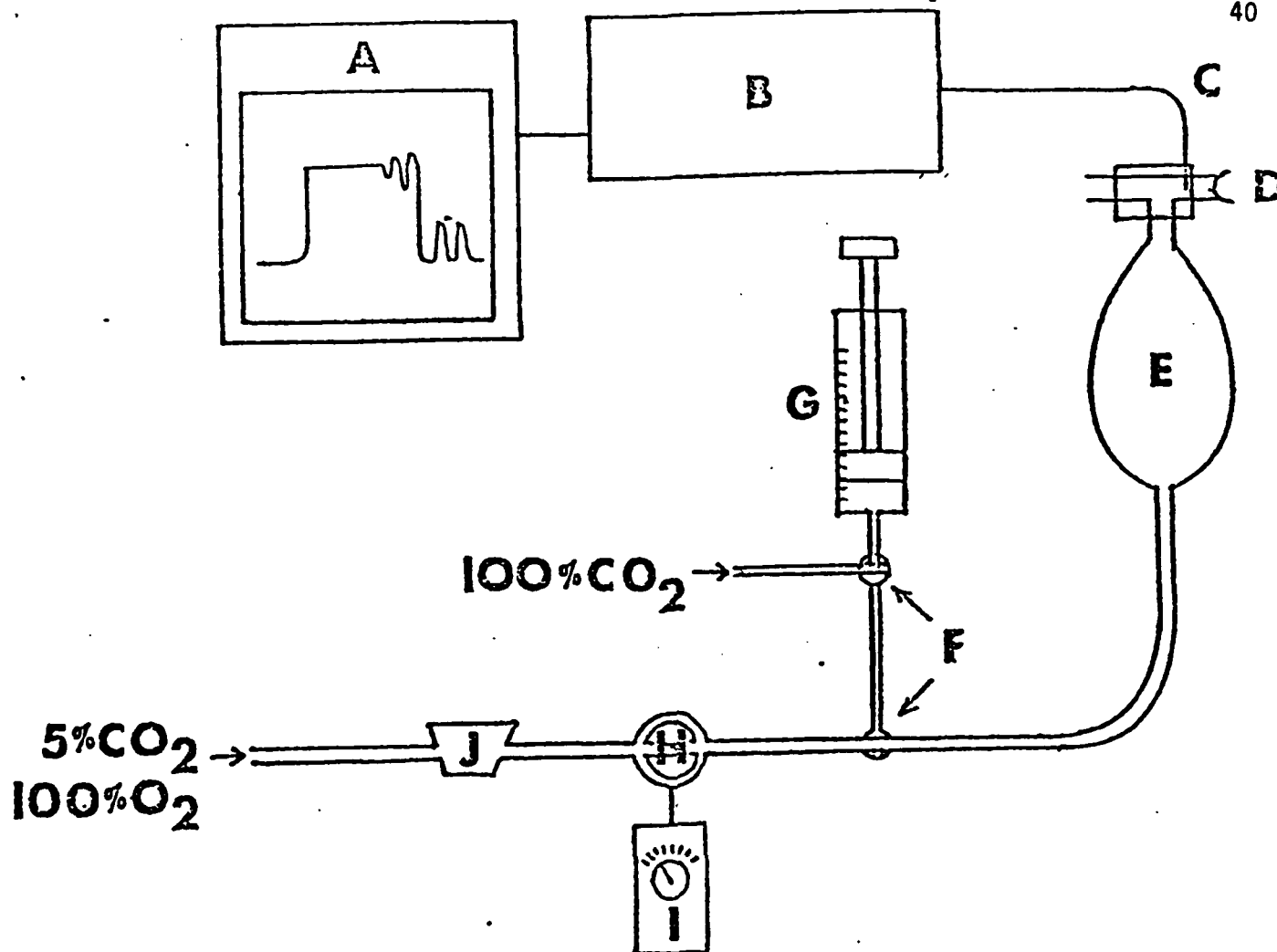

Cardiac output system, where: A is the strip chart; B is the carbon dioxide analyzer; C is the sampling line; D is the two-way valve; E is a 5-liter anesthesia bag; F are two three-way stopcocks; G is the 500 ml syringe; H is a solenoid valve; I is a time relay; and J is a pressure reducing regulator.

FIGURE E-1. from, E. Schelele, M.A. Thesis

Blood Pressure: Arterial blood pressure could be measured directly from the cannula placed in the left or right radial artery using a AE 845 physiological pressure transducer in conjunction with an carrier preamp mounted in a Hewlett Packard two channel 7402A recorder. Pressure recordings were standardized with a mercury manometer after each series of measurements. Interpretation of these tracings were as described by Holgrem (35).

E-8. IR-Thermography

Rapid transient changes in peripheral blood flow and resistance during the tilt procedure as measured by skin temperature are masked by the relatively slow responding thermistors. The search for a reliable and valid method to capture these transient changes led us to investigate the IR-Thermographic IR-R procedure. IR-R has the advantage of visualizing the temperature pattern over a wide surface region of the body.

A series of IR-R employing a AGA680 Thermovision system which displays 10-isothermal bars on a colored slave monitor in conjunction with a Bolex 16 mm movie camera was used to take real time movies at 16 frames per sec. (see reprint by Veghte, et. al. attached). The purpose of this experiment was to estimate the underlying peripheral vasomotor shifts reflected by shifts in skin temperature.

In the present study IR-R system appears to have significant advantages over the thermistor reflecting transient surface temperature changes corresponding to the on-off of exercise states associated with skin blood flow changes induced by a variety of exercises. These validation studies served as the basis for IR-R application by John Graham in his thesis to monitor changes in the surface temperature of the calf - transient pooling of blood in the limbs during tilt - referenced against a water bath maintained at 30°C measured by a ERTCO National Bureau of Standards - certified precision thermometer. Measureable and significant drops in skin temperature were detected within the 3-minute step interval periods (see B-5 of the working draft manuscripts).

E-9. Breathing Resistance

Breathing resistance and the associated cost of respiratory exchange were critical components in the investigation of metabolic costs of the L-1 straining maneuver reported under B-1 in this section. Applying varying resistances at different gas flows induced by graded loads of exercise (see reprint of manuscript by R. Dressendorfer JAP Respirat. Environ. Ex. Physiol. 42:(3), 1977, attached). Submaximal $\dot{V}O_2$ and anaerobic threshold were not affected by increasing resistances however, at $\dot{V}O_2$ max, both \dot{V}_E and HR were significantly reduced. Breathing 35% O_2 at the highest resistance increased all of the above measurements which were significantly reduced while breathing air only.

V.

FINAL SERIES OF STUDIES: COMPLETED AND IN PROGRESS

Background and Description of 1981-1983 Proposal

Description of study: This study was designed to observe the effect of physical training on the response of selected blood-borne endocrine substances to the 70-degree head-up orthostatic tilt.

There is a measureable difference between individual tolerances to this stress, and earlier work in this laboratory has established a working hypothesis that the individual's state of physical fitness and modality of training has a bearing on his ability to withstand this stressor. There seems to exist an inverse relationship between the amount of time spent in aerobic activity during the week and the individual's head-up orthostatic tolerance. In contrast, we have observed an increase in tolerance time with strength training in most of the subjects we have been able to test.

This raises the fundamental question regarding coping strategies in the presence of the stressor; is the strategy mostly one of resisting the stressor, or one of complying with the stress: This question is a modification of Selye's hypothesis regarding the resistance of stress. Selye insisted that the stress was always resisted (interestingly enough, his vertical axes were never labeled; I must assume he meant plasma cortisol levels, although he never said so) to the extent of the organism's ability to do so. If the stress continued, it eventually overwhelmed the organism and the system failed. If this hypothesis is true, then all responses to a stress would be essentially identical, and any differences would only be of degree.

The hypothesis presented here is that there is a fundamental qualitative difference in the way different organisms approach a stressful situation. The difference can be psychological or physiological or both. An example of this divergence to stress is reflected in the currently popular characterization of personality types as type A and type B. A type A personality compensates for the stress, and is subject to certain pathologies (hypertension, etc.), while the type B person is more apt to be "laid back" and not allow the stressor to cause him any noticeable perturbation.

If there is a difference in coping strategies to the orthostatic tilt, it would be expected that the response of hormones known to change titer in stressful situations would reflect this divergence. The current study is intended to investigate the response of plasma cortisol levels and the activity of renin to the tilt, and to see if tilt tolerance and the endocrine changes associated with it can be altered by physical training.

The subjects are unpaid male volunteers between the ages of 18 and 34 whose activity patterns range from moderately sedentary to moderately trained. This is intended to exclude extremely fit and extremely sedentary subjects.

The measurements are conducted in four batteries on at least three separate occasions, two for tilts, and one for max $\dot{V}O_2$ and body composition determination. During the consent process, while the study is being presented to the subject, he is tilted head-up for familiarization purposes prior to the

testing. Following this orientation, the first of the pre-training tests is the stepped-angle tilt. This test consists of a 12 minute tilt, with 3 minutes of the tilt spent at 10, 30, 50 and 70 degrees head-up. Blood samples are drawn prior to the tilt, at the end of each 3-minute period just before increasing the angle, and 5 minutes after the subject has returned to the supine position. Heart rate is monitored continuously via EKG leads, and the subject's blood pressure is measured at 30-second intervals throughout the tilt. The blood samples are assayed for plasma renin activity (New England Nuclear Angiotensin I radioimmunoassay kit, catalog #NEA-022), cortisol (competitive binding assay with tritiated CBG), hematocrit and hemoglobin.

The second test is a simple (non-graded) tilt that was allowed to go to end point (syncopal symptoms) or for 40 minutes, whichever was shorter. Blood is drawn prior to the tilt, at the end of the tilt, and 5 minutes after the subject returns to the supine posture.

The third test is a plasma volume determination, using Evans Blue dye as a marker substance. This test is usually combined with one of the tilts, as the subject is required to remain supine for 45 minutes prior to the tilt anyway. The fourth set of measurements is the bicycle max test and body composition determination. This test is ordinarily scheduled for some time other than either of the tilts.

Based on the prior observations concerning the effect of physical training on orthostatic tolerance, the subjects are assigned to a ten-week schedule of physical training. The modality of the exercise regimen is determined by the orthostatic tolerance of the subject. Tolerance is defined, for the purposes of this study, as the absence of syncopal symptoms, such as nausea, visual difficulties, vertigo, or the onset of bradycardia. If the subject is relatively tolerant (70 degree tolerance time of 20 minutes or more) he is assigned to ride a bicycle ergometer for 1 hour per day, 5 days per week, at 70% of his aerobic max. If the subject's tolerance time is less than 20 minutes, he is assigned to a specific weight training program. This bimodal approach to the training is based on prior observation in this lab that strength training such as weightlifting increases the subject's tolerance time significantly, while short term aerobic training either decrements the subject's tolerance time or does not significantly change it. We are attempting, by this cross training, to see if we can change the subject's physiological coping "strategy", as reflected in his endocrine response, to the stress of orthostasis. If indeed we are succeeding in converting the orthostatically intolerant subject's coping or avoidance stance into a resistant or "fighting" stance, we will be able to detect this change in terms of the humoral titer in the plasma. At the end of the training period, the subjects are retested in all four of the test batteries described above.

1. COMPARISON OF HEMODYNAMIC AND ENDOCRINE FACTORS DURING FIXED-AND STEPPED ANGLE ORTHOSTATIC TILT

J. F. Harrah and E. M. Bernauer
Department of Physical Education
University of California, Davis
Davis, California

INTRODUCTION

The orthostatic tilt has long been used as a model for the forces of head-to-foot acceleration ($+G_z$) (Graybiel, A. and R.A. McFarland, J. Aviat. Med. 12:1941). This study is an attempt to develop a short sub-maximal test for the purpose of investigating the early transient physiological adjustments to orthostasis. It was felt that perhaps there existed a fundamental difference between individuals of differing orthostatic tolerance in their physiological strategy toward blood pressure maintenance in the face of the orthostatic insult. The parameters considered were heart rate and blood pressure responses, hematocrit and hemoglobin responses, and humoral responses of cortisol and renin. These latter two were identified, in the case of cortisol, as a good general indicator of overall stress (Selye, Stress of Life, McGraw-Hill, 1956), and in the case of renin, as an indicator of the circulatory stress associated with the maintenance of blood pressure and plasma volume.

The advantages of a short progressive test were thought to be several. The first, and of practical importance, is that a short test doesn't take much of the experimenter's and subject's time. Secondly, unless the subject is very intolerant to orthostatic stress, the test will not induce syncopal symptoms in the subject. The onset of syncope can be a very stressful and unsettling experience for the subject, and, on occasion, to the experimenter. Thirdly, the transient physiological changes associated with the orthostatic tilt, such as the shift of plasma out of the central plasma volume, are slowed down; this proves to be very convenient in the application of an array of measurements which often entail slow and cumbersome methodology. Finally, a short test performed on a tilt table or tilt board of some sort is much less expensive than, for instance, a human centrifuge test and if valid would provide a desirable utility.

METHODS AND MATERIALS

The subjects for this study were 8 healthy male volunteers between 22 and 40 years of age. They were tilted on a manually-operated tilt table with a pneumatic saddle, a total of 6 times on separate occasions. Room temperature was maintained at 26°C (thermoneutral) for all tilts, and the subjects were clad only in gym shorts, to minimize skin thermoregulatory responses. All

of each subject's tilts were performed at the same time of day, with a minimum of four days between tests. The first five tests consisted of 12-minute head-up tilts with the angle of the table set at angles of 0 (horizontal), 10, 30, 50, and 70 degrees, respectively; the sixth test was a stepped-angle tilt with the subject spending 3 minutes each at 10, 30, 50, and 70 degrees, for a total of 12 minutes (See the attached experimental flow charts in Table 1).

The subjects were placed on the table 45 minutes prior to the beginning of the tilt, and were allowed to equilibrate in the horizontal posture for this period of time. During this equilibration time, the subject was prepped for EKG and blood pressure monitoring, and a venous catheter was placed in a superficial forearm vein.

The subject's EKG was monitored continuously via adhesive disposable thoracic silver-silver chloride electrodes (Hewlett-Packard 14445A), and blood pressure was taken at 30 second intervals by sphygmomanometry. Blood samples were drawn through an indwelling #21 butterfly catheter from the antecubital vein; the catheter was kept patent with a 10% sodium heparin lock. The blood was drawn into 10 ml plastic syringes and immediately transferred to vacuum collection tubes (Vacutainer) containing tripotassium-EDTA as an anticoagulant. The syringes and vacuum collection tubes were kept on ice prior to use and the tubes containing the samples were immediately placed into an ice-water slurry.

The first sample was drawn 20-25 minutes after the catheter was inserted, just prior to onset of the tilt. 10 ml samples were drawn at the end of each 3 minute stage during the stepped-angle tilt, and the final sample was drawn 5 minutes after the subject returned to the horizontal posture. Sampling for the fixed-angle tests (10, 30 degrees, etc.) was similar in that there was a pre- and post-tilt sample, but during the test proper, samples were drawn at minutes 1, 2, 3, 4, 6, 8, 10, and 12.

Each blood sample was assayed for hematocrit, hemoglobin concentration, plasma sodium and potassium concentration, plasma renin activity and cortisol as described in Table 2. Plasma volume shifts were calculated using the equation of Costill and Fink (JAP 37(4), 1974). Plasma renin activity was assayed using a commercially available angiotensin I kit (#NEA 022, New England Nuclear). Cortisol was assayed using a competitive protein binding assay (Moberg, et. al. J. Endocr., 90:221-225, 1981). Sodium and potassium concentrations were determined via flame photometry.

RESULTS

Hemoglobin Concentration: Hemoglobin data is presented graphically in Figure 1. The increase in hemoglobin concentration is, of course, due to hemoconcentration as a result of filtration in the dependent parts of the body. The concentration of hemoglobin increased significantly ($p < 0.05$) over the 12 minutes of the 70 degree tilt, and by the end of the 70 degree stage of the step tilt. The two Hb concentrations (the 12 minute point of the fixed 70 degree tilt compared with the 12 minute point of the step tilt) are not significantly different from one another. Comparison of the Hb concentrations amongst the other tilt angles produced no significant change in hemoglobin within the 12 minute limit.

Hematocrit changes rapidly with a change in posture, and this is reflected in Figure 2. Hematocrit changed significantly between the 50 and 70 degree tilts, and during these two stages of the step tilt. It might also be noted at this point that two of the subjects became syncopal during both the 50 and 70 degree tilts; their tolerance even at 50 degrees was less than 12 minutes.

Plasma Shift: Plasma shift, calculated from hematocrit and hemoglobin, is also presented in Figure 3 as a histogram of these values. Since this is a derived value calculated from two changing values, it changes very rapidly. Applying a $p < 0.05$ value for significance, the change in plasma volume reaches a critical level by 3 minutes at 70 degrees, 6 minutes at 50 degrees, and by the 12 minute end of tilt at 30 degrees. The 12 minute values for each fixed angle tilt were not significantly different from the value at the end of the corresponding 3 minute stage in the stepped-angle tilt. Steady-state values were usually achieved by around minute 8; from this point to end point, the values at each tilt angle were not significantly different from those of the neighboring angles, but were from the remaining angles. It is noteworthy that the value for plasma shift at 70 degrees, 12 minutes (-10.05% for fixed tilt, -11.03% for step tilt) is in the same range for the change in plasma volume after maximal exercise, approximately -13% (J. Novosadova, Eur. J. Appl. Physiol. 36:223-230, 1977).

Plasma Electrolytes: We didn't seriously expect to see a change in plasma electrolytes in such a short tilt, but documented information on the time course of such changes is rather scarce and it was deemed worthy of pursuing these analysis. Hesse, et. al. (Hesse, B., Ring-Larsen, H., Neilsen, I., and Christensen, N.J., Scand. J. Clin. Lab Invest. 38:163-169, 1978) reported a decrease in renal sodium filtration during 60 degree head-up tilting. Our pre-experimental expectations were fulfilled for the most part, in that the plasma sodium and chloride concentrations did not change. Plasma potassium concentration, however, did show a significant increase ($p < 0.05$) over 12 minutes at 70 degrees and are shown in Figure 4a and 4b. In contrast with the above variables the step tilt did not produce this same increase.

Heart Rate: Heart rate is the most rapid of the changes we observed and is directly responsive to the drop in blood pressure which shows an early continuous transient drop. By minute 12 of the fixed tilt, heart rate was significantly elevated in the 30, 50, and 70 degree tilts. Comparison of steps 50 and 70 degrees of the step tilt also showed a significant increase in heart rate when compared to the equivalent 12 minute fixed angle tilt, see Figure 5.

Blood Pressure: Pulse pressure was significantly reduced at the end of the 50 and 70 degree fixed tilts when compared to the equivalent degrees of the step tilt (see Figure 6). This reflects the continuing transient adjustment of the cardiovascular system when undergoing serial incremental step tilt demands. Higher heart rates and blood pressures contribute to the elevated pulse pressures recorded during the step tilts. The increased heart rates are in response to a decreased venous return caused by the continuing transient hemodynamic changes of the step tilt. In the relaxed state of the tilt, the intra-abdominal pressure is probably insufficient to manage effective venous return.

Mean arterial pressure (MAP) was not significantly altered during either the step tilt or the fixed angle tilts, see Figure 7. This is not surprising

since the MAP is the most lightly regulated variable of the many CV-variables we observed. It raises a question as to the role played by the baroreceptors under these circumstances as opposed to the peripheral vascular events including the hormonal agents on blood pressure control. In either case heart rate and the pulsatile flow are the more sensitive and responsive to the transient changes induced by step tilt.

DISCUSSION

It would appear that a short, variable-angle tilt is a valuable tool for the observation of transient hemodynamic and neurally-mediated events occurring early in orthostasis. The gentle nature of the test is reflected in the fact that plasma cortisol does not change over the 12 minute duration of the tilt. Obviously, this test is of limited or no utility if the investigator is interested in observing stress-related endocrine changes, since in most cases, the test is not stressful to the subject; however it does have potential predictive utility with respect to identifying the immediate pressure flow response between fainters and non-fainters (Graham, J., M.S. Thesis, UCD).

Hemodynamic changes were observed to be extremely rapid in onset, especially heart rate. We were somewhat surprised to find the 30-degree tilt to be so effective in producing hemodynamic changes. By the end of the 12-minute tilt, both heart rate and plasma volume had been significantly altered. In all tilts, the majority of total change to be expected from an end-point tilt had been observed in the first few minutes of each tilt. Longer scenarios tend to simply show a slow decay of the blood pressure maintenance system, probably due to slow filtration in the dependent parts of the body.

As of yet, it is not possible, from this data, to predict the subject's orthostatic tolerance. If this were the object of the research, then several possibilities come to mind as predictors. First would be the time course of plasma catecholamines, and time of onset. If cortisol levels are considered a secondary effect of an increase in titer of circulating catecholamines, this might not be a good possibility; However, the response of the adrenal cortex is probably too slow to be considered a good predictor, and the titer of norepinephrine, especially, would make a better candidate. Another good possibility would be the rate of change or slope of the plasma shift. It is conceivable that an index of the "leakiness" of the subject's circulatory system would have good predictive value for orthostatic tolerance. This latter index may well be related to the increased density of capillaries at lower peripheral resistance observed by Mangseth and Mole in their respective studies elsewhere in this report cited.

Table 1. TILT PROTOCOLS FOR TRAINING STUDY AND ENDOCRINE RESPONSE

TILT 1

Protocol Time (min)	Prep Subject	Insert Catheter	Begin Tilt/	End Tilt or Syncope	Recovery in Horizontal Posture
0	0 ECG BP-Cuff	0	5	15	5
5		5	10	20	10
10		10	15	25	15
15		15	20	30	20
20		20	25	35	25
25		25	30	40	30
30		30	35	40	35
35		35	40	40	40
40		40	40	40	40
45		45	45	45	45
50		50	50	50	50
55		55	55	55	55
60		60	60	60	60
65		65	65	65	65
70		70	70	70	70

Monitor continuously throughout the experiment

Blood Draw #1
25 ml blood sample
10 ml for cortisol & PRA
15 ml for Hct, Hb, electrolytes & osmolarity

Blood Draw #2
End Tilt or Syncope

Blood Draw #3
5-min. Post Tilt

TILT 2

Protocol Time (min)	Prep Subject	Insert Catheter	Begin Tilt	End Tilt
0	0 ECG BP-Cuff	0	3	5
5		5	6	10
10		10	9	15
15		15	12	20
20		20	15	25
25		25	18	30
30		30	21	35
35		35	24	40
40		40	27	45
45		45	30	50
50		50	33	55
55		55	36	60
60		60	39	65
65		65	42	70
70		70	45	75

Monitor continuously throughout experiment

Blood Draws
1 @ 0°
2 @ 10°
3 @ 30°
4 @ 50°
5 @ 70°

Blood Draws
6 @ 5' rec
7 @ 10' rec

10 ml blood sample for Hct, Hb, cortisol & PRA

TABLE 2. EVANS BLUE DYE BLOOD VOLUME DETERMINATION PROTOCOL

Time (min)	0	20	30
	Subject Resting	Dye Equilibration Time	Post Blood Sample Taken
	••	Pre Blood Sample & Dye Injected	

10 ml Blood Samples

- a) centrifuged, plasma extracted
- b) plasma washed & eluted after procedure by Campbell et al, J. Lab. Clin. Med. 52:768, 1958
- c) samples brought to volume with acetone-water (50/50) and read on Beckman D.U. @ 615 mμ
- d) plasma volume = $\frac{\text{vol dye} \times \text{dilution std} \times \text{O.D.} \times \text{vol extract}}{\text{O.D. test plasma} \times 10^3}$
- e) blood volume = plasma volume $\times \frac{100}{100 - (0.87 \text{ Hct})}$

LEGEND FOR FIGURES 1 THROUGH 7:

3 min



Pre-tilt Baseline Values



Incremental Tilt Values at Specified Tilt Angles



Initial Values Prior to 12 Minute Tilt at Given Angle



Values Recorded After 12 Minute Tilt at Corresponding Tilt Angle

HEMOGLOBIN CONCENTRATION (MG DL⁻¹)

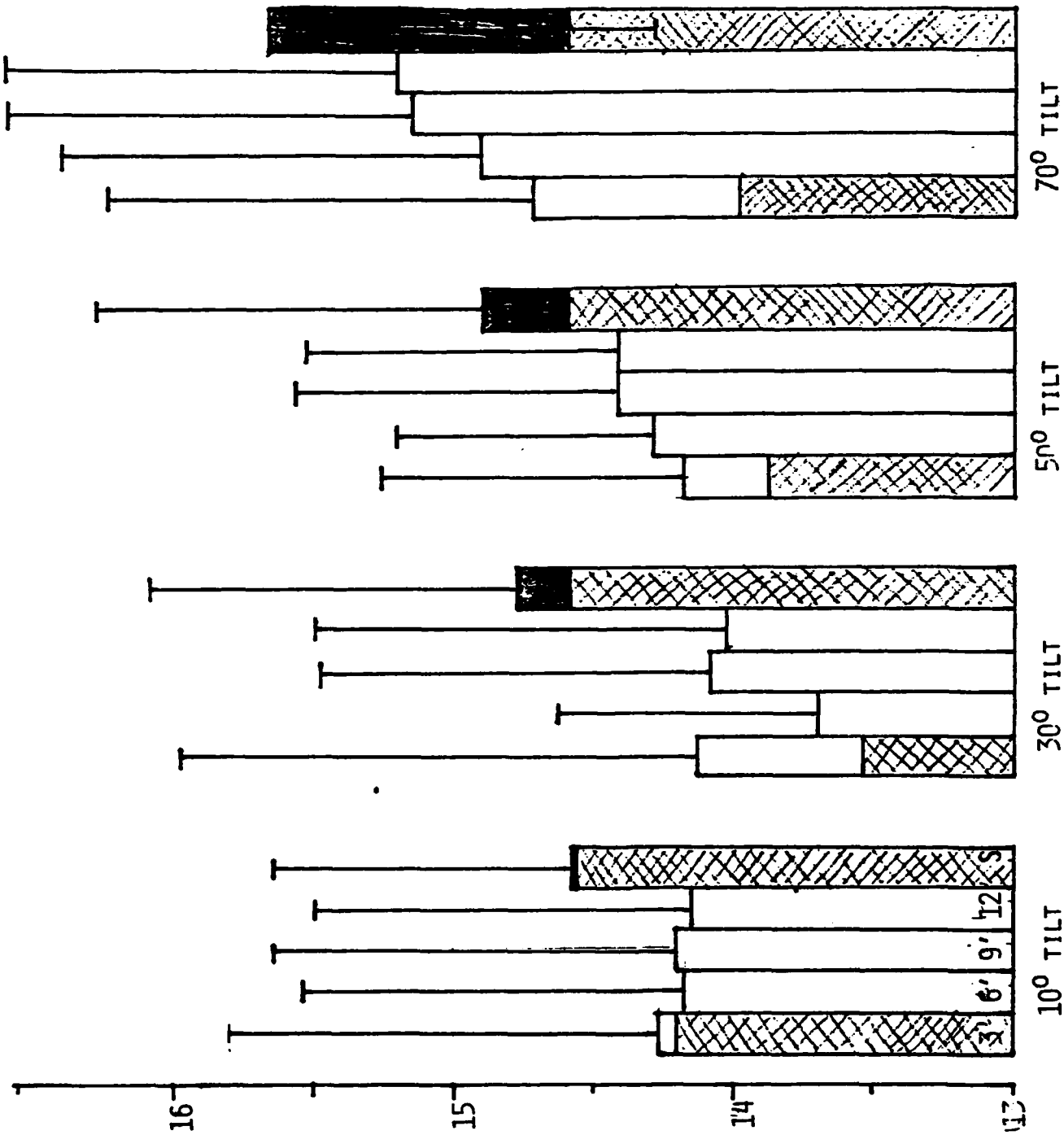

FIGURE 1: CHANGES IN HEMOGLOBIN CONCENTRATION IN STEPPED VS FIXED ANGLE TILTS

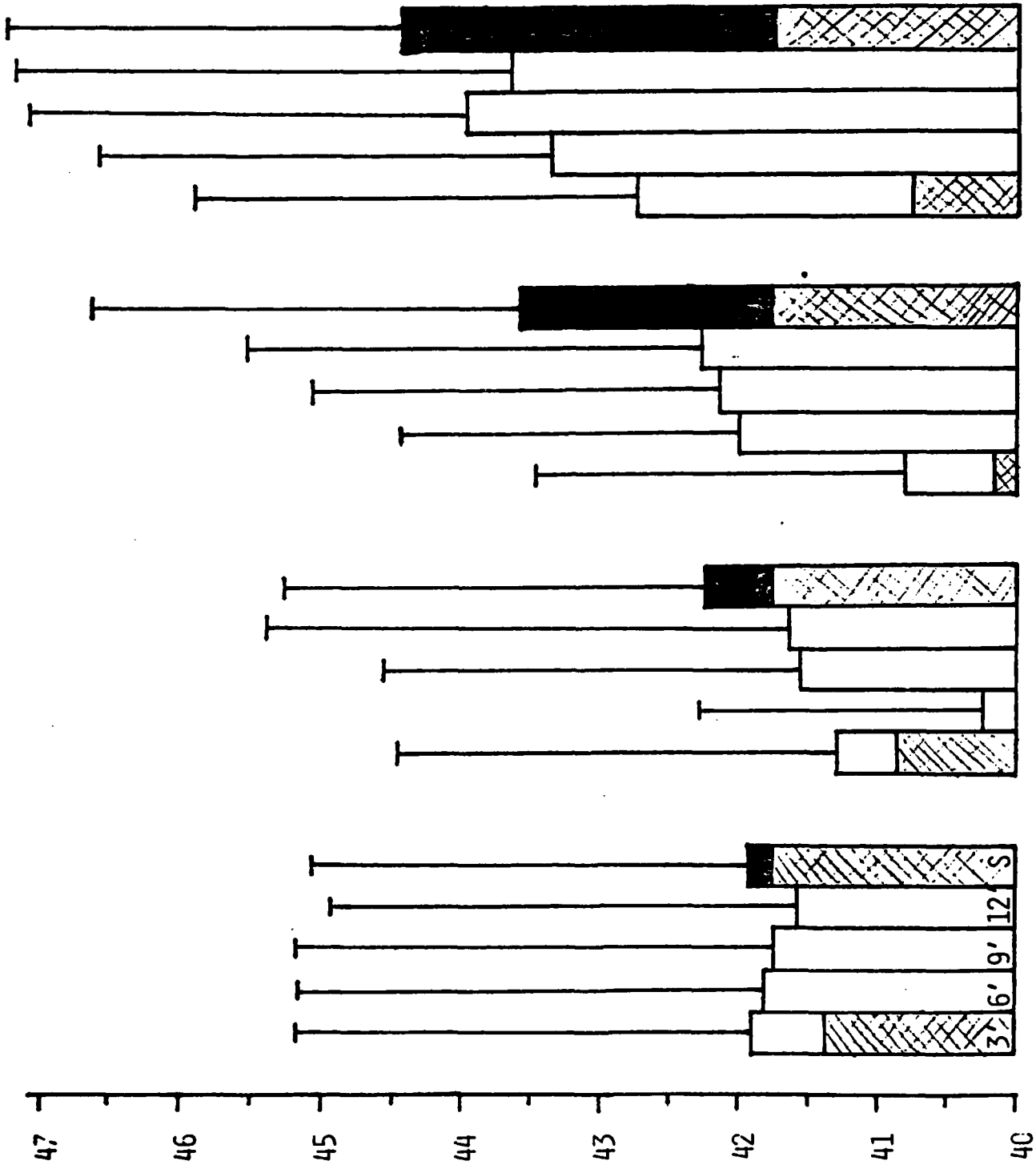

FIGURE 2: COMPARISON OF HEMATOCRIT CHANGES IN STEPPED VS. FIXED ANGLE TILTS

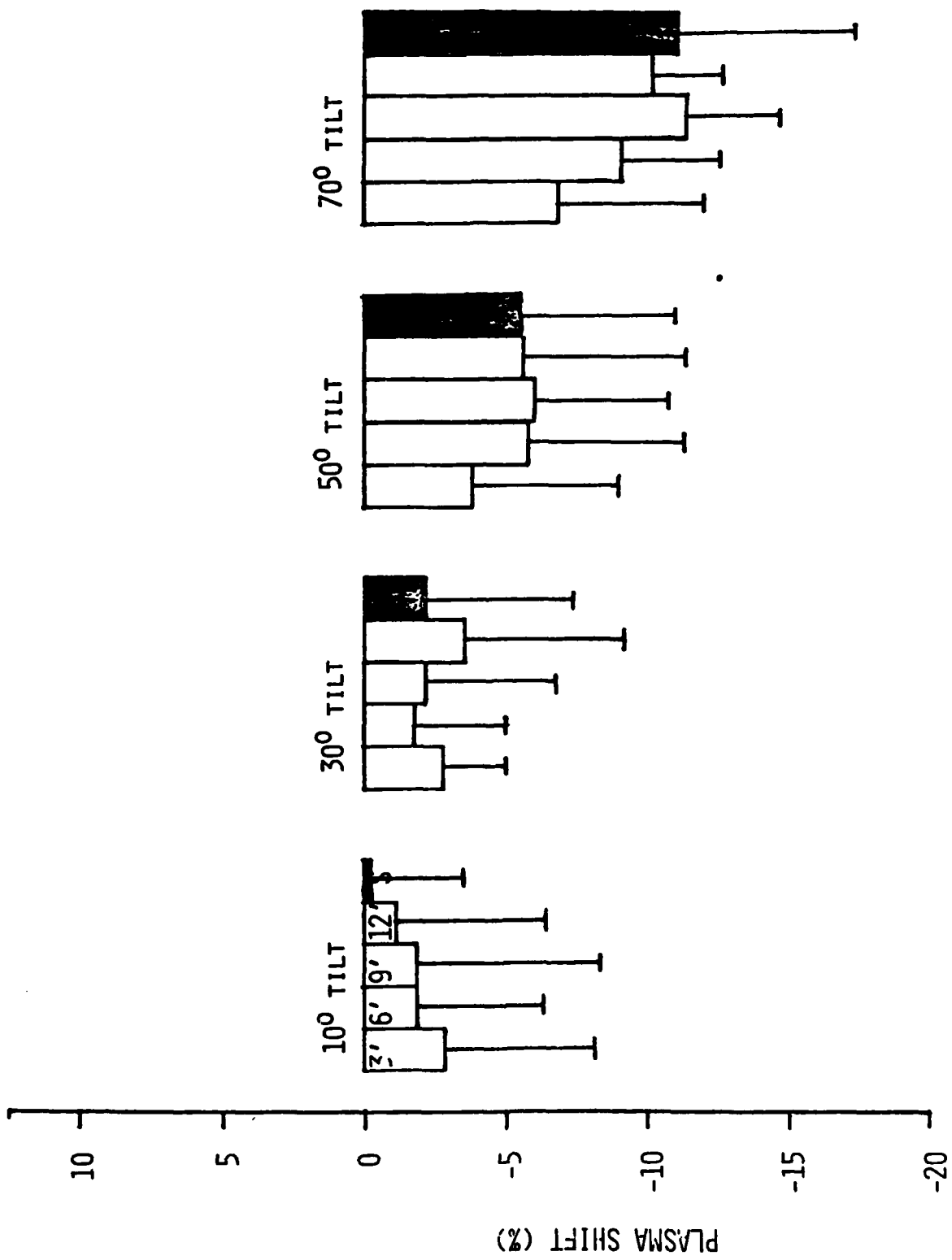

FIGURE 3: COMPARISON OF PLASMA SHIFTS IN STEPPED VS FIXED ANGLE TILTS

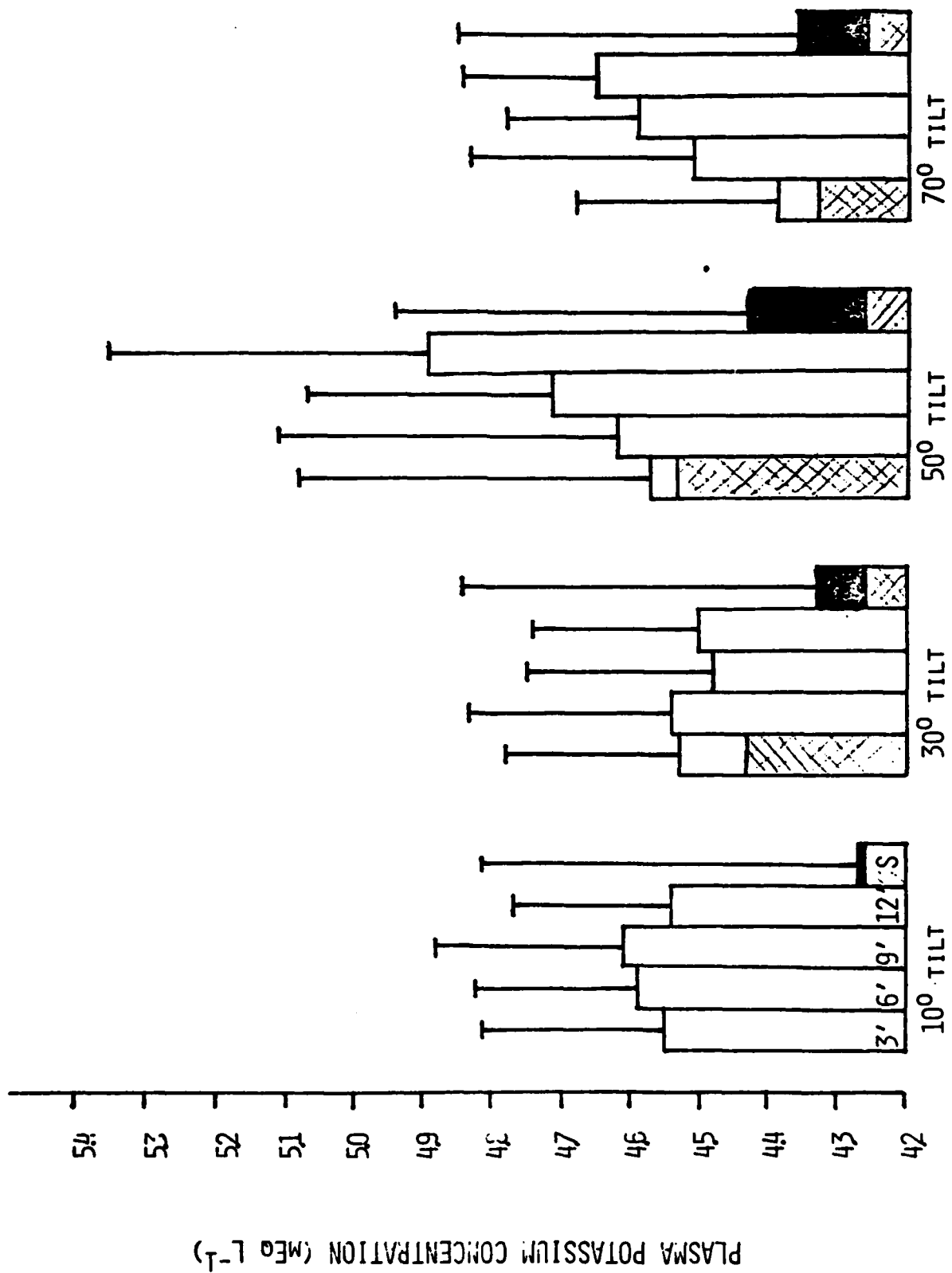

FIGURE 4a. COMPARISON OF PLASMA POTASSIUM IN STEPPED VS FIXED ANGLE TILTS

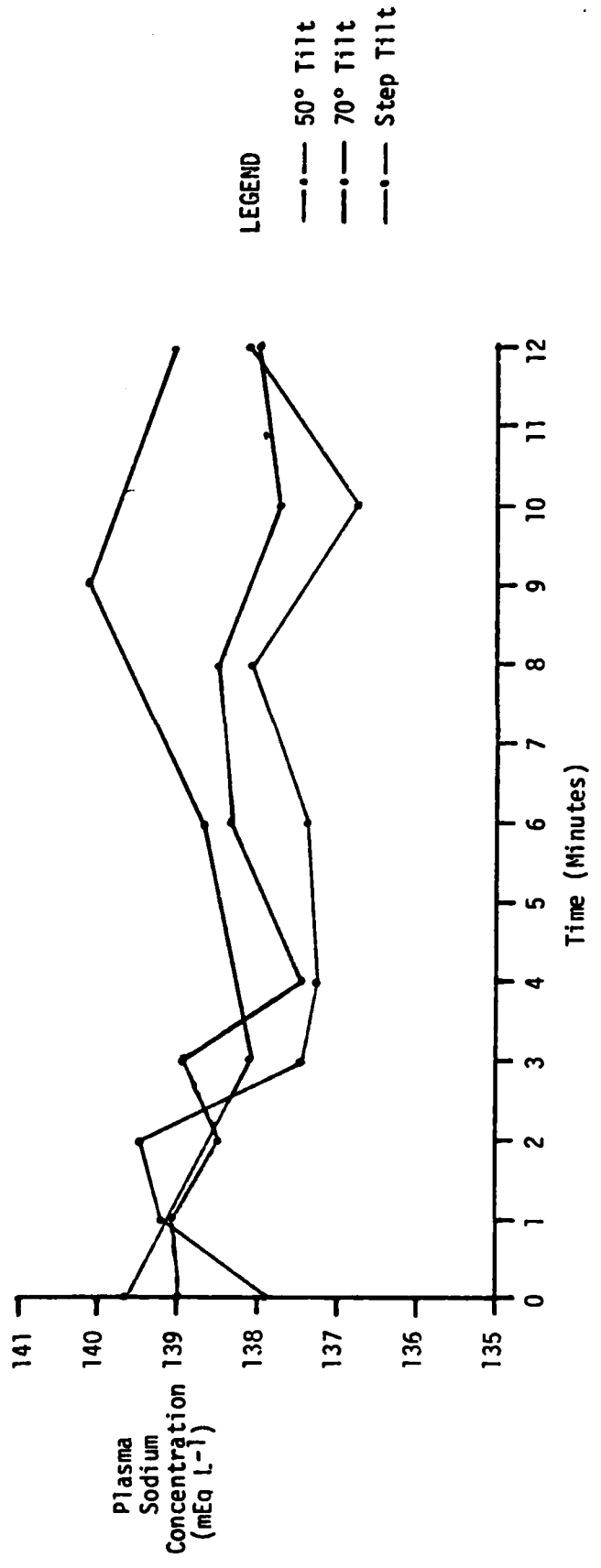
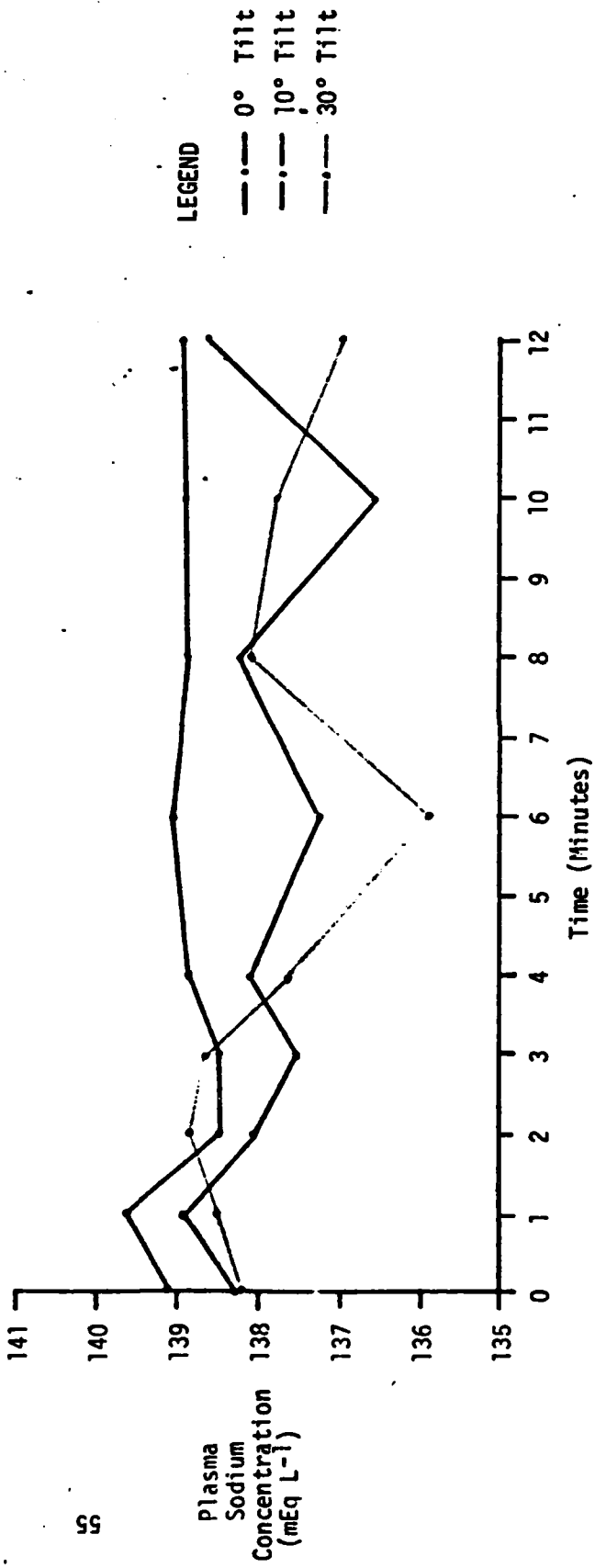

FIGURE 4b. Comparison of plasma sodium response in fixed-angle vs. progressive stepped-angle tilt.

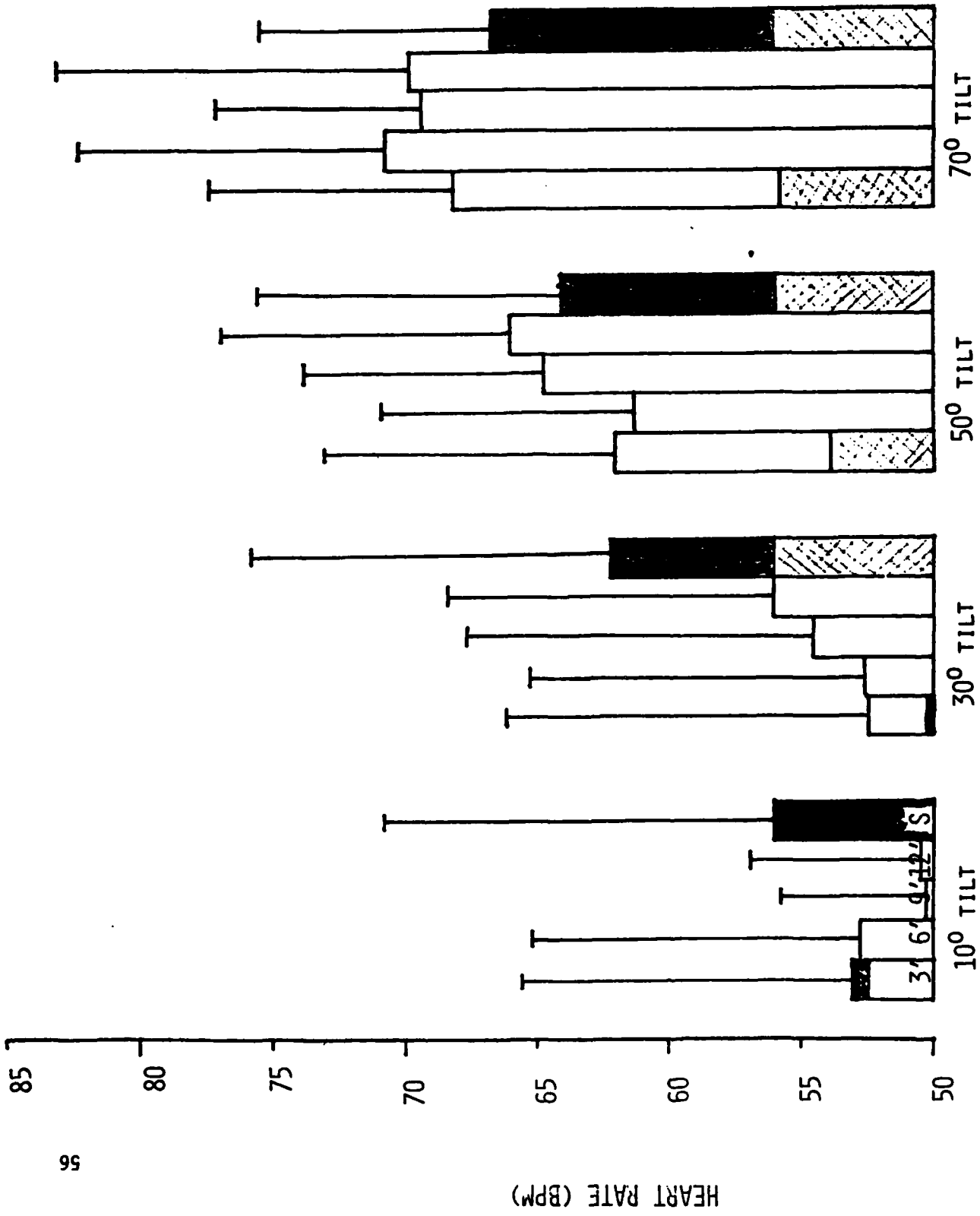

FIGURE 5: COMPARISON OF HEART RATES IN STEPPED VS FIXED ANGLE TILTS

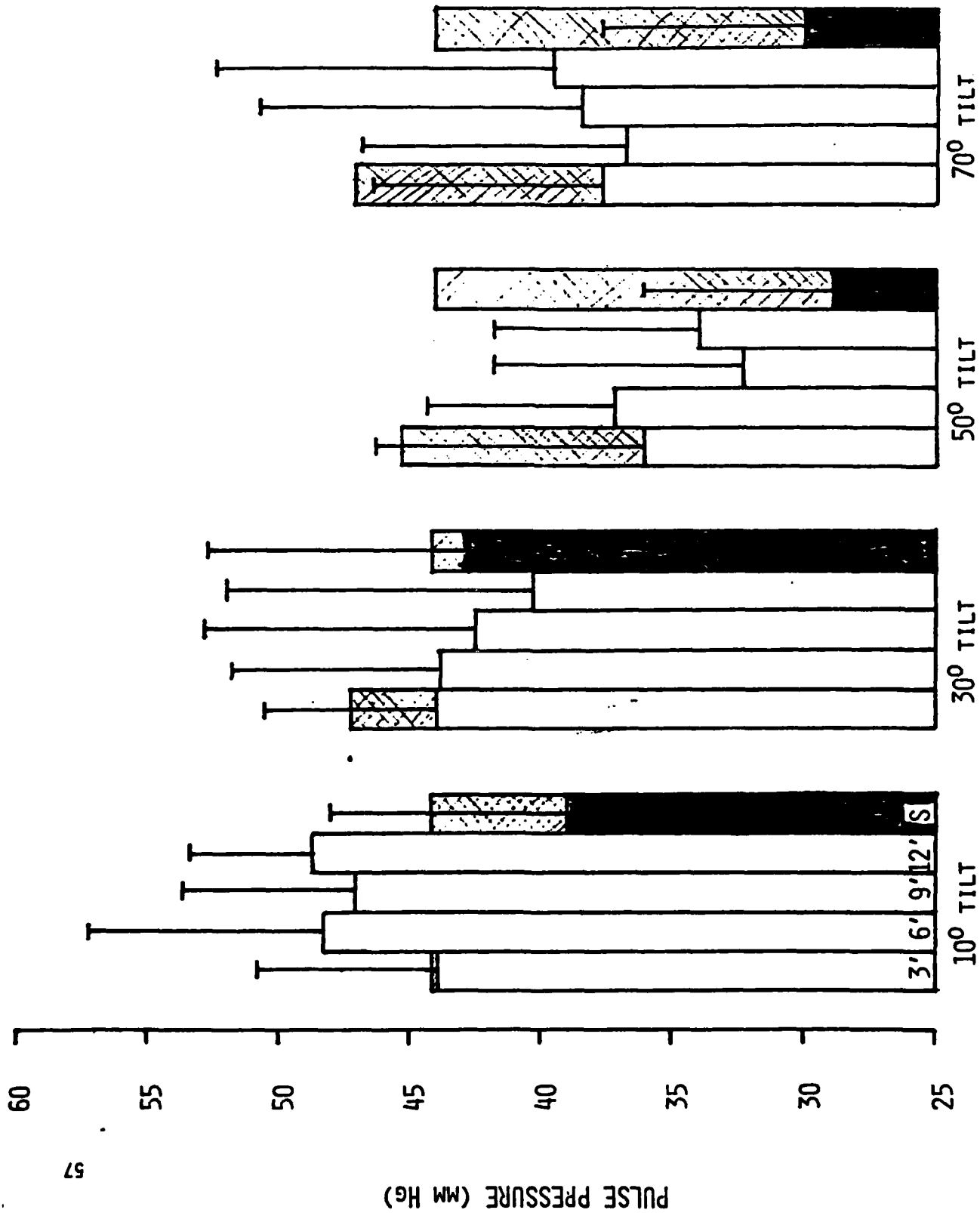

FIGURE 6: COMPARISON OF PULSE PRESSURE IN STEPPED VS FIXED ANGLE TILTS

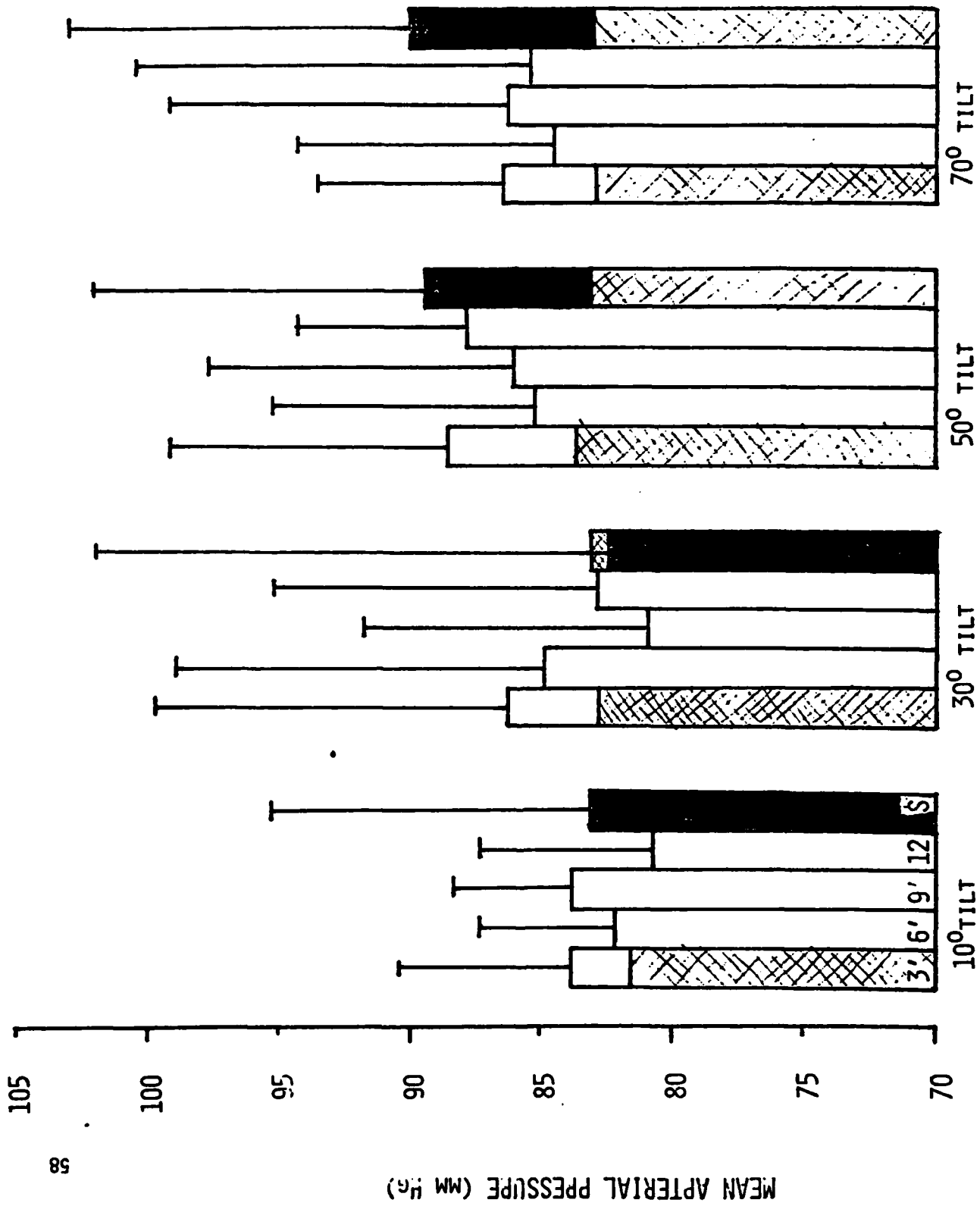

FIGURE 7: COMPARISON OF MEAN ARTERIAL PRESSURE IN STEPPED VS FIXED ANGLE TILTS

TABLE 3

Cortisol and PRA During Step-Tilt and Fixed Tilt

	Pre Training Step Tilt						Pre Training 70° Tilt		
	Pre Tilt	10°	30°	50°	70°	5' Post	Pre Tilt	End	5' Post
[F]	15.91	18.01	17.97	13.85	18.38	18.10	11.06	22.35	18.57
S.D.	4.85	10.03	8.40	6.86	8.68	6.94	3.29	15.06	8.94
PRA	12.10	9.95	14.20	13.05	15.70	19.70	9.80	39.25	31.32
S.D.	13.66	9.49	16.67	15.26	13.14	17.27	9.90	23.25	21.03

Subjects Completed

	Post Training Step Tilt						Post Training 70° Tilt		
	Pre Tilt	10°	30°	50°	70°	5' Post	Pre Tilt	End	5' Post
[F]	17.72	18.94	18.36	18.02	20.36	20.80	11.47	21.42	26.07
S.D.	2.91	4.24	6.11	5.55	5.43	7.97	1.88	6.94	13.79
PRA	8.60	6.04	7.98	9.55	8.80	11.45	5.41	48.00	34.98
S.D.	5.49	3.74	5.47	6.06	5.85	10.88	2.55	28.01	17.27

Control Subjects

	Step Tilt						70° Tilt		
	Pre Tilt	10°	30°	50°	70°	5' Post	Pre Tilt	End	5' Post
[F]	21.66	21.26	23.25	20.43	25.13	24.71	14.42	15.82	18.40
S.D.	5.02	3.80	6.06	5.17	9.99	7.65	4.20	2.99	7.06
PRA	18.30	16.80	13.70	15.80	17.50	20.60	8.57	30.20	22.80
S.D.	8.07	10.67	6.95	11.06	13.99	13.82	9.20	38.80	21.41

n = 6 Total
 4 Weight Lifters
 1 Endurance Bike Ergometer
 1 Control

[F] = [Cortisol], mg/dl
 Pra = plasma renin activity, mg/ml/hr

2. EFFECT OF 10 WEEKS OF PHYSICAL TRAINING ON ORTHOSTATIC TOLERANCE AND ENDOCRINE RESPONSE TO THE ORTHOSTATIC TILT

J. F. Harrah and E. M. Bernauer

Department of Physical Education
University of California, Davis
Davis, California

INTRODUCTION

This study was undertaken to observe the effect of physical training on the response of selected endocrine substances to the 70 degree passive head-up orthostatic tilt. There is a measurable difference between individual tolerances to this stress, and previous work in this laboratory (Mangseth, Bernauer, Graham - Abstracts and Manuscripts attached to this report) has established a working hypothesis that the individual's state of physical fitness and modality of training has a bearing on his ability to withstand this stressor. Within our subject population we have observed an inverse relationship between the volume of weekly aerobic activity and the individual's head-up orthostatic tolerance (personal communication). Conversely, we have observed an increase in tolerance time with strength training in most of the subjects tested to date. In contrast, we have not been able to demonstrate a significant decrement in tolerance time due solely to endurance training.

This raises a fundamental question regarding coping strategies in the presence of orthostatic stress; is the strategy mostly one of resisting the stressor, or one of complying with the stress? This question is a modification of Selye's hypothesis regarding a subject's response to stress. Selye in his book (Stress of Life, 1956) insisted that the stress was always resisted to the extent of the individual organism's ability to do so. (As an aside, it is interesting that Selye never labeled his vertical axes when presenting graphic representations of the organism resisting a chronic stress. He often alluded to corticosteroid responses, especially cortisol, but does not specifically designate this as his "response".) According to Selye's hypothesis, if the stress continues, it will eventually overwhelm the organism's adaptive capabilities and the system will fatigue and eventually fail. If this

hypothesis is true, then all psychosomatic responses to a given stress would be essentially identical, with any differences being only of degree.

The hypothesis presented in the present study in contrast is that there is a fundamental qualitative difference in the way individual organisms respond to a given stressful environment. This difference can be physiological or psychological or both. An example of this divergence of response to general stress is the currently clinical trendy characterization of personality types as Type A or Type B. The Type A personality compensates for the stress, and is subject to certain pathologies (hypertension, e.g.) as a consequence of this resistance. The Type B individual, in contrast, is more apt to be "laid back" and will not (cannot?) allow the stressor to cause him any noticeable perturbation; appears to accommodate or attenuate the stress.

If there is indeed a corresponding divergence in coping strategies to the orthostatic tilt, it would be expected that the plasma titer of hormones known to be stress responsive (or products of their target tissues) would reflect this difference. The present study is intended to investigate the response of plasma cortisol levels and renin activity to the tilt, and to see if tilt tolerance and associated endocrine changes can be altered by physical training.

METHODS AND MATERIALS

The subjects for this study (n=5 completed to date) were healthy male volunteers aged 18 to 31. Most were normally active college aged men, although the continuum of physical activity ranged from completely sedentary through ultramarathon. All were unpaid volunteers who were fully informed of the experimental procedures and signed sanctioned subject consent forms. The subjects were tested in three test batteries prior to and following a 10 week training period. The first test was a 70 degree passive head-up tilt to syncopal symptoms or 40 minutes to determine orthostatic tolerance (see Experimental Flow Chart attached-Tilt Protocol #2). The third test battery was for the purpose of subject characterization and anthropometry which included reasurements of body size, composition, aerobic and anaerobic capacity and blood volume.

The tilt table used for the two different tilt tests was a manually operated model with a pneumatic saddle for the subject to rest on. The subjects were prepped as previously described by Graham (M.S. Thesis, UCD, 1981) using a stepped angle tilt protocol. During the tilts, EKG was continuously monitored, and the subject's blood pressure was determined by sphygmomanometry at 30 second intervals. Subjects were returned to the horizontal position at the onset of syncopal symptoms, although in some instances the onset of symptoms and the syncopal episode itself were almost simultaneous. Blood samples were drawn from the left antecubital vein through an indwelling heparin-locked butterfly catheter. Samples were drawn during the fixed-angle tilt prior to the tilt, at the termination of the tilt, and five minutes into recovery from the tilt. Blood was drawn during the discontinuous or stepped-angle series tilt prior to the onset of the tilt, at the end of each 3 minute stage (10, 30, 50 and 70 degrees) and 5 minutes into recovery.

Subject characterization test battery consisted of a bicycle ergometer $\dot{V}O_2$ max test and a body composition determination using immersion. The

TABLE 1. TILT PROTOCOLS FOR TRAINING STUDY AND ENDOCRINE RESPONSE

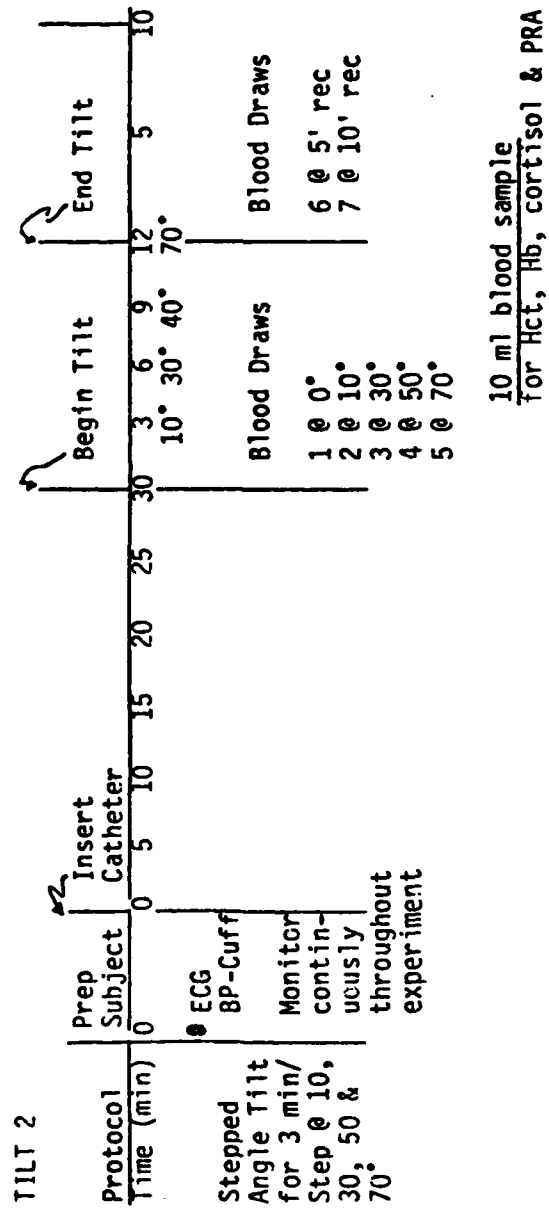
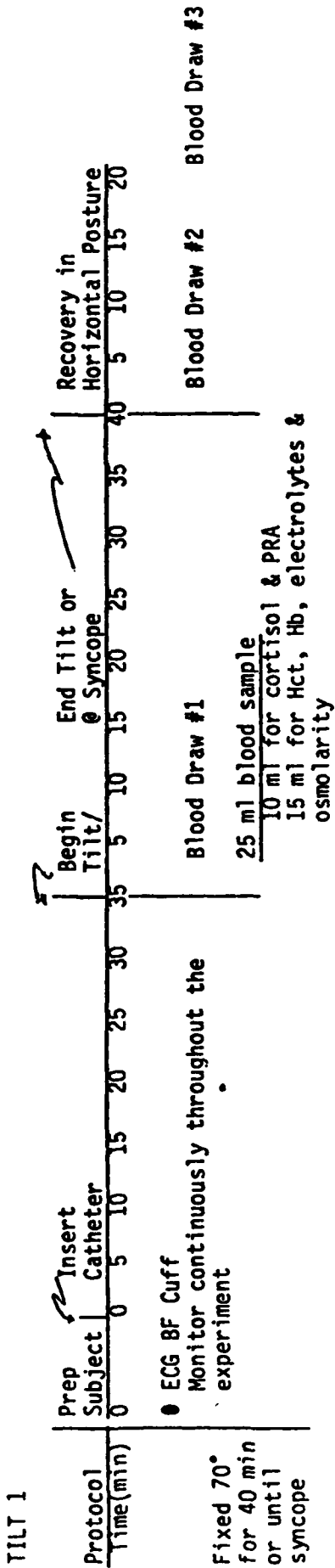

TABLE 2. EVANS BLUE DYE BLOOD VOLUME DETERMINATION PROTOCOL

Time (min)	0	20	30
	Subject Resting	Dye Equilibration Time	Post Blood Sample Taken
		Pre Blood Sample & Dye Injected	

10 ml Blood Samples

- centrifuged, plasma extracted
- plasma washed & eluted after procedure by Campbell et al, J. Lab. Clin. Med. 52:768, 1958
- samples brought to volume with acetone-water (50/50) and read on Beckman D.U. @ 615 um
- plasma volume = $\frac{\text{vol dye} \times \text{dilution std} \times \text{O.D.} \times \text{vol extract}}{\text{O.D. test plasma} \times 103}$
- blood volume = plasma volume $\times \frac{100}{100 - (0.87 \text{ Hct})}$

bike max was an extremely strenuous one; the subjects pedaled at 60 rpm, and the workload was set at 2 kp for the first 2 minutes, then the workload was increased 1/2 kp per minute until volitional fatigue. The typical time course of this test was 7 to 10 minutes. The body composition was determined using Brozek's (Densiometric Analysis of Body Composition, N.Y., Ann. Academy of Sci., 1963), and the subject's residual volume was determined by the nitrogen washout method (Wilmore, A simplified method for determination of residual lung volumes, JAP 27:96-100, 1969).

One repetition maximum of the arm-shoulders, trunk and legs were obtained as reference to changes induced by the strength training regimens. Blood volume was measured by the Evans Blue technique as modified by Young, H.L., et al. (NASA Tech. Rep. R-406, 1973, pp.19).

The training modalities included a 10-week regimen of all-around weight lifting engaged in a minimum of 3 days/week for 60-minutes/day. The lifts included strength efforts for all the major muscle groups of the upper body, trunk and the lower body. The lifting protocol emphasized load and maintained the repetitions at a maximum of 8-reps for 3 sets based upon the principle of overload and reported by Berger, R. (Research Quarterly 33:1962). The endurance training regimen utilized the bicycle ergometer for 60-minutes/day, 3 days/week at an intensity that would raise the heart rate to a minimum of 70% of the measured HR max.

RESULTS

See Table 1 attached.

Table 3. Effects of Cross Training on Specific Modalities of Exercise and Controls

Subjects	$\dot{V}O_2$		% Body Fat		Body Weight (kg)		Tilt Tolerance (min)		Age	End-70° Pre	Tilt Post
	Pre	Post	Pre	Post	Pre	Post	Pre	Post			
Lifters											
SC	58.8	57.1	11.4	9.14	68.34	69.42	15:30	24:30	23	-8.21	-20.26
SD	58.8	61.1	7.9	7.7	68.75	67.62	15:00	32:11	23	-16.20	-26.98
CM	39.9	47.4	18.76	16.46	77.00	76.33	18:00	34:00	30	-12.96	-16.98
ES	---	---	---	---	---	---	40:00	40:00	---	-11.00	-17.16
Ergometer											
	64.3	69.0	11.0	9.8	77.78	76.46	40:00	31:00	31	-17.22	-16.53
Controls											
SD	58.2	---	8.8	---	71.24	---	14:30	---	20	-16.17	---
TK	55.6	---	10.0	---	78.56	---	37:35	---	24	-15.24	---
SL	47.4	---	14.21	---	80.59	---	19:30	---	19	-14.81	---
RG	54.0	50.2	14.7	18.3	84.08	87.83	40:00	40:00	29	-18.50	-17.02

* Work is continuing; in part to satisfy a Ph.D. Dissertation by Mr. Jack Harrah

DISCUSSION AND CONCLUSIONS

This study has not been completed at this time. The number of subjects completed is not sufficient to draw any conclusions about the effect of physical training on the endocrine response to the tilt. Only one subject successfully completed the ergometer training regimen, and he was rather an unusual individual. Some preliminary conclusions can be arrived at concerning the effect of strength training on the tilt response, since 4 subjects have completed the training.

The most pronounced effect of the lifting program, aside from the augmentation of orthostatic tolerance, is the increase in plasma renin response. Pre training, the subjects' mean PRA during the 70° tilt increased approximately 4X; after the training program, the subjects' mean PRA increased by a factor of 8.87X the baseline value. The mean tolerance time went from 16:28 (min;sec) to 30:19 with the weight training regimen; as this does not perhaps reflect a change in the rate renin activity increment, but rather the increased time from tilt onset to syncope. Cortisol levels changed comparably during the 70° tilt pre and post training, so that the cortisol levels were about the same at the onset of syncopal symptoms regardless of the state of the subject's training. The obvious conclusion is that some aspect of the training has caused the tilt to be less stressful; the subject's cortisol levels were the same, and it took twice as long to achieve these levels. End-tilt plasma shift data may also reflect a larger plasma volume shift. Our next study will investigate the time course of the cortisol and PRA response. We currently do not know if the cortisol increases rapidly at some point in the tilt, or if the increase is linear with time. Since there was no significant increase in cortisol during a 12 minute tilt (step tilt study), the former hypothesis is more attractive, but the nature of the time course of the increase is still obscure at this time.

VI.

PUBLICATIONS AND MANUSCRIPTS IN PREPARATION

A. Publications

1. Stremel, R.W. et. al. Modeling static and dynamic human cardiovascular responses to exercise. Computer Programs in Biomedicine. 4:246-252, 1975.
2. Dressendorfer, R.C., Wade and E.M. Bernauer. Combined effects of breathing resistance and hyperoxia on aerobic work tolerance. J.A.P.
3. Vaghte, J., W.C. Adams and E.M. Bernauer. Temperature changes during exercise measured by thermography. Aviat. Space & Environ. Med. 50(7):708-713, 1979.
4. Epperson, L., W. Lewis, R.R. Burton, E.M. Bernauer. Influence of differential physical conditioning regimens on simulated aerial combat maneuvering tolerance. Aviat. Space & Environ. Med. 50:1091-1097, 1982.
5. Mole, P.A., T. Barstow and B. Anderson. Effects of HSG on oxidative capacity and proteolytic activity of the chicken heart and leg muscles. Physiologist. 22(4):89, 1979.
6. Holly, R.G. and P.A. Mole. Stretch induced growth in chicken wing muscle: A new model of stretch hypertrophy. Am. J. Physiol. 238(Cell Physiol. 7):662-671, 1980.
7. Adams, W.C. Blood volume in young men and women: Relation to body composition and aerobic capacity. Med. Sci. Sports & Ex. 12(2) May, 1980.

B. In Preparation

1. Mangseth, G.R. et. al. Blood resistivity changes associated with orthostatic and exercise stress: Impedance cardiac output implications. J. Appl. Physiol.
2. Mangseth, G.R., E.M. Bernauer, et. al. Comparison of anthropometric and functional characteristics of fainters vs. non fainters to 70° head-up tilt. Aviat. Space & Environ. Med.
3. Graham, J., E.M. Bernauer, et. al. Applications of two differing tilt formats and determination of optimal time dicotomies to predict orthostatic tolerance. Aviat. Space & Environ. Med.
4. Harrah, J.F. and E.M. Bernauer. The effect of exercise training on orthostatic tolerance and related endocrine response. J. Appl. Physiol.
5. Bernauer, E.M., and J. F. Harrah. Metabolic costs and physiological stress measured during static leg L-1 maneuver at 1G_z. Aviat. Space & Environ. Med.
6. Mangseth, G.R. and E.M. Bernauer. Cardiovascular response to postural change in normal and dystrophic individuals. J. Phys. Med. & Rehab.

VII.

Presentations at Professional Meetings

1. Bernauer, E.M. and J.F. Harrah. "Physiological responses to L-1 strain-maneuver. 1979 Review of Air Force Sponsored Basic Research in Environmental and Acceleration Physiology Meeting. October, 1979.
2. Bernauer, E.M. and G.R. Mangseth. "The effects of body somatotype and training modalities on orthostatic tolerance." 1979 Review of Air Force Sponsored Basic Research in Environmental and Acceleration Physiology Meeting. October, 1979.
3. Schultz, C.K., E.M. Bernauer, P.A. Mole, H.R. Superko, and J.S. Stern. "Effects of severe caloric restriction and moderate exercise on basal metabolic rate and hormonal status in adult humans." FASEB Annual Meeting, Anaheim, CA. April, 1980.
4. Mangseth, G.R. and E.M. Bernauer. "Cardiovascular response to tilt in endurance trained subjects exhibiting syncopal reactions." American College of Sports Medicine Annual Meeting. Las Vegas, May, 1980.
5. Harrah, J.F. and E.M. Bernauer. "Metabolic costs and physiological stress measured during exhaustive static leg effort." American College of Sports Medicine Annual Meeting. Las Vegas, May, 1980.
6. Mangseth, G.R. and E.M. Bernauer. "Blood resistivity changes associated with orthostatic and exercise stress: Impedance cardiac output implications.: American College of Sports Medicine Annual Meeting, Miami, 1981.
7. Graham, J.G. and E.M. Bernauer. "The cardiovascular response to orthostasis in man: Variations in orthostatic tolerance. American College of Sports Medicine, Miami, 1981.
8. Harrah, J.F. and E.M. Bernauer. "Comparison of plasma shifts and electrolyte data in progressive-stepped tilt vs. fixed angle tilt. Annual Review Air Force Office of Scientific Research Environmental Physiology and Biodynamics, Aerospace Lab, San Antonio, March, 1982.
9. Bernauer, E.M. "The validation of a progressive incremental head-up tilt against a constant 70° head-up tilt. Annual Review Air Force Office of Scientific Research Environmental Physiology and Biodynamics, Aerospace Lab, San Antonio, March, 1982.
10. Holly, R.G. and C.R. Ashmore. Hypertrophy and hyperplasia in chicken wing muscle due to stretch. Med. Sci. Sports & Ex. 9:66, 1977.
11. Mole, P.A., R.G. Holly, J.G. Barnett, C.R. Ashmore, and R.G. Taylor. Stretch-induced growth in chicken wing muscles: A new model of stretch hypertrophy. The Physiologist 22(4):89, 1979.

12. "Stretch-induced growth in chicken wing muscles: A new model of stretch hypertrophy." (Physiologist 22:89, 1979). American Physiological Society Meeting, New Orleans, Louisiana, October, 1979.
13. "Effects of two exercise programs on performance and skeletal muscle oxidative capacity." (Physiologist 22:111, 1979). American Physiological Society Meeting, New Orleans, Louisiana. (Presented by W.R. Sandel). October, 1979.
14. "The effects of acute +6G_z acceleration stress on endurance performance of male chickens: Involvement of oxidative capacity in heart and leg muscles. Annual Meeting of Air Force Office of Scientific Research Review of Sponsored Research, St. Louis, Missouri, October, 1979.
15. Daly, N. and W.C. Adams. Thermoregulatory responses of highly trained men and women during exercise in neutral and warm-humid conditions. Med. Sci. Sports & Ex. 12:82, 1980.
16. Paumer, L. and W.C. Adams. Thermoregulatory responses of highly trained men and women during exercise in neutral and hot-dry conditions. Med. Sci. Sports & Ex. 12:82, 1980.
17. Adams, W.C. Blood volume in young men and women: Relation to body composition and aerobic capacity. Med. Sci. Sports & Ex. 12:97, 1980.

VII.

DEGREES AWARDED

- Robert G. Holly, Ph.D., October, 1979
The Effects of Stretch on Skeletal Muscle growth and Development
- William Lewis Epperson, Ph.D., January, 1980
The Effect of Physical Conditioning on +G_z Tolerance
- Thomas Jackson Barstow, M.A., October 1979
A Comparison of the Kinetics of O₂ Uptake Between Diabetics and Non-Diabetics
- Linda Paumer, M.A., October, 1979
A Comparison of Thermoregulatory Mechanisms in Trained Male and Female Distance Runners during Exercise In Hot-Dry Heat
- Nick Daly, M.S., October, 1979
Thermoregulatory Responses of Highly Trained Men and Women during Exercise in Neutral and Warm-Humid Conditions
- John G. Graham, M.S., October, 1981
The Cardiovascular Response to Orthostasis in men: Variations in Orthostasis Tolerance

DEGREES IN PROGRESS

- Glen R. Mangseth, Ph.D., 1985
Blood Resistivity Changes Associated with Orthostatic and Exercise Stress: Impedance Cardiac Output Implications
- Jack F. Harrah, Ph.D., 1985
The Effect of Specific Modalities of Training on Orthostatic Tolerance and Associated Endocrine Response

VIII.

PRINCIPAL INVESTIGATORS AND ASSOCIATES

Edmund. M. Bernauer, Ph.D.
Paul A. Mole, Ph.D.
William C. Adams, Ph.D.
Robert G. Holly, Ph.D.
W. Lewis Epperson, Major USAF, Ph.D.
Robert El. Smith, Ph.D.
Anthony DeMaria, M.D.
Glen R. Mangseth, M.S.
Jack F. Harrah, M.S.
Linda C. Paumer, M.A.
Nick Daly, M.S.
John Graham, Captain USAF, M.S.
Tom Barstow, M.A.
Bonnie Anderson, M.S.
Michael Hellmer, B.S.

The above associates have made significant contributions to the ongoing studies under the research project supported by the USAFOSR 78-3510. All have culminated in documented theses or publications. All theses are in the process of being edited for submission for publication.

IX.

COLLABORATIVE ASSOCIATIONS

1. During the past, I have had three extensive working sessions with Dr. Russ Burton of the Aerospace Lab in San Antonio. These sessions included review and analysis of thesis data collected by Dr. Lewis Epperson while at UCD; and the application of these findings to planned and ongoing research at the USAFSAM. These studies include the development of specific exercise training regimens for flight personnel designed to increase their $+G_z$ tolerance. The emphasis of the exercise programs is to minimize the need for equipment, and time while optimizing the rate of strength gain for abdominal, arm and leg muscles thought to be fundamental to the significant gain in HSG-tolerance reported by Epperson.

2. Cooperative efforts between the HPL at UCD and the Biodynamics branch at Wright-Patterson AF Base have been sustained through the effort of Dr. Jim Veghte. We have had the use of a thermovision system to explore its application during our standard tilting procedures used to measure the orthostatic tolerance of a broad spectrum of males ranging in somatotype and specific physical conditioning. Details of the application of this technique to the basic question of physical conditioning and $+G_z$ tolerance is contained under one of the current proposals for this coming calendar year.

3. Our laboratory resolved the computer problems of Major James Elliot at the Air Force Academy, Colorado Springs. They had adopted the on-line data acquisition system used in our laboratory for stress testing individuals and titrating their functional aerobic capacity. This stress testing procedure is an important testing component of their longitudinal study of the effectiveness of the Academy's physical training program and the long term fitness profile of a designated sample of the career officer graduates of the Academy.

4. Dr. Michael Ziegler has generously provided the technical expertise of his laboratory to analyze the blood samples for catecholamines on our subjects engaged in cross-training studies of an endurance or strength modality. A potentially productive interaction is developing between our laboratories focusing on the use of catecholamines as a marker of orthostatic stress amongst individuals varying in age, somatotype, and the specificity of their physical conditioning, viz., levels of aerobic vs. anaerobic capacity.

5. Dr. Paul Mole has interacted with Dr. A. Smith, a fellow grantee on the UCD campus. Both are using the chicken as a model in their respective investigation on the role of the CV system in determining HSG tolerance. Dr. Mole's investigative effort has focused on the effect of endurance training on the change in HSG tolerance. The interchange between these two investigators has proven beneficial.

6. Dr. Jerry Green of the UCD Medical School at UCD has recently been awarded a grant by the OSR. His research interests using the dog as a model to investigate various parameters of the venous circulation has some compelling parallels to our research. The experiments will involve invasive techniques to measure the blood pressure, flow, resistance and a-v differences in a stratified sampling of adult males previously measured in our laboratory. The criteria for sampling stratification will include tolerance to head-up orthostatic tilt, functional aerobic capacity, training mileage and somatotype. A major focus of experimental interest involves the effect of abdominal volume and pressure on orthostatic tolerance.

APPENDIX-A
Section IV
Manuscripts in Preparation
Working Drafts

Cardiovascular and Metabolic Dynamics During Graded Straining Maneuver

Performed at One Gravity

by

Ed. Bernauer

Jack Harrah

and

Anthony Christo

INTRODUCTION

The development of the modern generation high speed aircraft has shifted the tolerance limitation in the man-hardware system to the human component. To further complicate the existing man-hardware balance, the conventional view of the salutary role of endurance training - aerobic functional capacity - in support of centrifugation (+G_z) tolerance has been challenged. Recent investigations in active and passive centrifugation have observed significant benefits accruing to subjects following a regimen of strength training (L. Epperson's Ph.D. Dissertation, UCD, 1980). The underlying physiological mechanism responsible for this increased acceleration AT tolerance is not presently understood, however, it seems empirically clear at this point that strength training is specific to the increased tolerance.

PROBLEM

To answer the questions relating the role of physical status, and specificity of training to AT, it seemed appropriate to more closely examine the stress experienced by man performing a straining maneuver at one gravity independent of the other stressors generally associated. There appears to be three fundamental stressors, viz., the acceleration, per se, the related orthostatic hypotension, and the L-1 straining maneuver used to combat the hypotension. To our knowledge, no one has investigated the stress generated to the skeletomuscular system or the heart by the straining maneuver, per se. Recent findings in our laboratory and others suggest that orthostatic tolerance is better served by strength training. We designed an experimental approach to address the above questions and concerns.

1. To apply a metabolic stressor in the form of a nL-1 straining maneuver.
2. To assess the metabolic energy requirement and its major components.
3. To assess the cardiodynamic response and the general stress.

EXPERIMENTL DESIGN

The experimental protocol for the L-1 straining maneuver was as follows: 1) to fix the static leg effort at 35, 55 and 75%, respectively, for a period of 5 minutes or until volitional fatigue, while executing L-1 maneuvers on a 3-5 second cycle. The experimental configuration and protocol are illustrated in Figures 1 and 2. Respiratory gas exchange, heart rates, systolic blood pressures at eye level, blood gases, lactates, and catecholamines are collected before and after each effort. These data serve as the bases of assessing the physiological stress related to the straining effort. The subjects' physical characteristics are summarized in Table 1, 2, and 3.

EXPERIMENTAL METHODS

Measurements were made of respiratory gas exchange using a Vertek pneumotach in tandem with a mixing chamber and a Beckman L-2 CO₂ and OM-11 gas analyzers. A three-way valve was inserted into the expiratory line to collect end-tidal gas as required without interrupting the respiratory collection. Heart rate was monitored continuously with an R-wave detector

in conjunction with a digital recorder. Blood pressure was measured manually by a sphygmomanometer and recorded manually. The experimental configuration and protocol are illustrated in Figures 1 and 2.

Blood samples were drawn through a butterfly venocut indwelling catheter. Lactates were analyzed by Sigma enzymatic method. Catecholamines were analyzed in Ziegler's laboratory using the specific radioenzymatic method by (Lahe, C., Ziegler, M. and Kopin, I., Life Science 18:1976).

Cardiac dynamics were monitored using both IFM electrical impedance as described by Kubicek, W.G. (J. Assoc. Adv. Med. Instrumentation 4(2):1970) and echocardiography as described by DeMaria in (Chapter 15:Congestive Heart Failure, N.Y. Yorke Medical Bks. Dun-Donnelley Publ., 1976).

The physical straining effort generated by leg extension against a force plate was continually displayed on an oscilloscope with a split image containing the required static effort for purposes of visual feedback and control. Failure to maintain the prescribed effort $\pm 10\%$ for a 10 second period resulted in the termination of the straining effort.

RESULTS

Body size favored the endurance trained individuals who were on the average taller $\Delta + 10$ cm, heavier $\Delta + 6$ kg and had a $\dot{V}O_2$ max $+ 6$ ml/kg $^{-1}$.min $^{-1}$. Percent body fat and blood volume were essentially the same between both groups, viz., 12.7 vs. 11.9% and 6893 vs. 6541 ml for percent fat and blood volume for the endurance trained and normals, respectively.

Strength characteristics of subjects showed that the non-trained group demonstrated greater respiratory power $\Delta + 36$ mmHg $\pm 20\%$ and trunk (abdominal) strength $\Delta + 12$ sec $\pm 22\%$ than the endurance trained. Further there is a significant positive correlation between the respiratory power and the abdominal strength measured by static curl. The difference between the two groups in dynamic arm and leg strengths were small 10 and 0%, respectively, for the arms and legs.

The respiratory exchange is summarized in Table 4. The columns reading from left to right give the O_2 exchange at rest, total O_2 during the L-1 maneuver and recovery, the net O_2 -intake during the L-1 maneuver and recovery.

Figure 3 shows a generally suppressed $\dot{V}O_2$ intake during the course of the straining maneuver (SM) followed by an immediate large increase following the SM. $\dot{V}O_2$ recovered by one to two minutes of recovery. Figure 4 reveals a slight fall in the true O_2 with time of effort, with the exception of one subject who endured 4-minutes at 75% of maximal effort. Expired CO_2 rises moderately during the course of the SM and rebounds dramatically at the termination of the SM. Recovery is similar to that for $\dot{V}O_2$. Figure 6 shows a transient rise and fall in R during the course of the SM. This could be an artifact of the L-1 maneuver breathing demands, however, the R generally reveals a predominant glycolytic-anaerobic metabolic process. The delayed response may indicate a trapping of CO_2 in the muscle during the straining-isometric muscle phase.

$\dot{V}O_2$ intake during either the longest bout (35% max) or heaviest bout (75% max) was very moderate averaging approximately 1 l/min as recorded in Table 4, column E. The aerobic fraction ranges from 63, 39, 26% for 35, 55 and 75% of static leg max. Conversely anaerobic effect was 37, 61, and 74% for the respective workloads (Table 4, column E). Duration for each of the static leg efforts were 5:00 (all subjects able to complete) at 35%, 2:53 and 1:56 for 55% and 75% respectively. The 35% effort is below critical tension in which most of the peripheral vascular bed is clamped, thus more easily maintained aerobically (see Table 4, column D).

Lactic acid values following the SM are reported in Table 5. This compares favorably with values recorded following acceleration tolerance. The highest values observed are thought to reflect the time and intensity experienced at 55% SM.

The general heart rate response is presented in Figure 7. The marathon trained group had lower resting heart rates but the response to the SM was similar in both groups. There was an immediate rise and then elevated maintenance of the heart rate throughout the course of the SM effort. The recovery time requires 3-5 minutes on the average; or at times longer.

Eye level systolic blood pressure was driven up rapidly and continued to rise throughout the course of the SM effort, Figure 8. No differences were observed between groups. The L-1 procedure obviously is effective in increasing the eye level pressure, which is the primary purpose of the procedure. The apparent lag in pressure rise is an artifact of the measurement procedure. Systolic pressure rises 2-fold in all SM efforts.

Stroke volume, Figure 9, shows a resting value of approximately 110 ml/b; when multiplied by the resting HR, approximately 52, equals a cardiac output of 5.7 l/min. These values are well within the normal range and reflect the validity of the echo-technique for making these measures under standardized conditions. The stroke volume rose quickly with the start of the SM effort, was maintained until the fourth minute and then sharply fell. The same pattern of response was seen for the cardiac output, Figure 10, and the ejection fraction, Figure 11. The primary drive to the increased cardiac output is the heart rate and not the stroke volume, consequently, the changes in the ejection fraction and shortening fraction are primarily the result of the chronotropic responses of the heart. The fall in the cardiac output in the fourth minute of the SM effort can be attributed to a reduction in ejection fraction. The driving stimulus for the heart rate is the reduced venous return and the general sympathetic response as seen by the 2 to 3 fold rise in nor-epi (Figure 12).

The marathon endurance trained individuals, indicated on Tables 2 and 3, tended to manifest a reduction in either their end-diastolic diameter or end-systolic diameter for a net reduction in ejection or shortening fractions during the SM effort. The non-endurance athletes appeared to maintain the above cardiac dynamics more stably throughout the straining effort. Recovery appeared to be complete in all subjects after 10 minutes. No categorical distinction could be made between the above two physically fit groups based on left ventricle mass which ranged from 185-286 grams, or the increase in HR during the 5 minute straining effort.

DISCUSSION AND CONCLUSIONS

The experimental protocol presently developed to measure the physiological response to the L-1 straining maneuver is feasible and quantitatively reproducible. It provides a direct method of measuring respiratory gas exchange, blood gas changes, cardiovascular response and stressor indices in the blood, e.g., catecholamines. The physical effort has been quantified with reference to static leg strength and standardized during the SM maneuver in terms of percent maximum. A pre-testing battery of anthropometric and functional properties provide a bases for characterizing all subjects and normalizing the data sets.

The respiratory gas exchange during the SM effort revealed that the metabolic demands were essentially anaerobic. The magnitude of the energy demands are relatively modest however, and it suggests a high dependence on the capacity for immediate source of muscular energy, i.e., high energy phosphates. How this metabolic picture might change with a more prolonged repetitive SM format remains to be seen. One striking feature of the gas exchange is the observation that resting metabolic $\dot{V}O_2$ was not satisfied during the SM. It emphasizes the high dependence on anaerobic processes, however by comparison with other types of physical effort lactate levels are moderately low yet comparable to those reported following acceleration. The minimal recovery ranges between two and three minutes.

The echocardiographic measurements during the SM effort proved to be a feasible method of observing the cardiac dynamics during high levels of static exercise. The seated subject is in an ideal posture for the stable positioning of the ultrasound sensor critical to the M-mode recording. The central dynamic changes of the cardiac response were clearly monitored.

The initiation of the SM produced a fast response increase in heart rate forced elevated cardiac output. This is reflected in both the shortened time intervals for the ejection and shortening fractions. Although the evidence is far from clear cut, there appeared to be greater stability in the non-marathon group, with respect to the maintenance of cardiac output than the marathon group. At the end of the L-1 maneuver, the off response in cardiac output is equally fast. The critical point during the SM effort occurs between minutes 3 to 4, where there is a large drop in cardiac output. This appears to be due to a reduction in the ejection fraction and secondarily to a small drop off in heart rate.

The stress of the L-1 technique is reflected in the 2 to 3-fold increase in nor-epi coupled with the sharp precipitant rise in systolic blood pressure.

The basic physical-physiological profile of the orthostatic tilt tolerant and able SM individual appear to be a mesomorphic body type, above average strength of the trunk and anaerobic capacity coupled with greater respiratory power. High aerobic fitness is not an advantage to performance under straining efforts associated with acceleration.

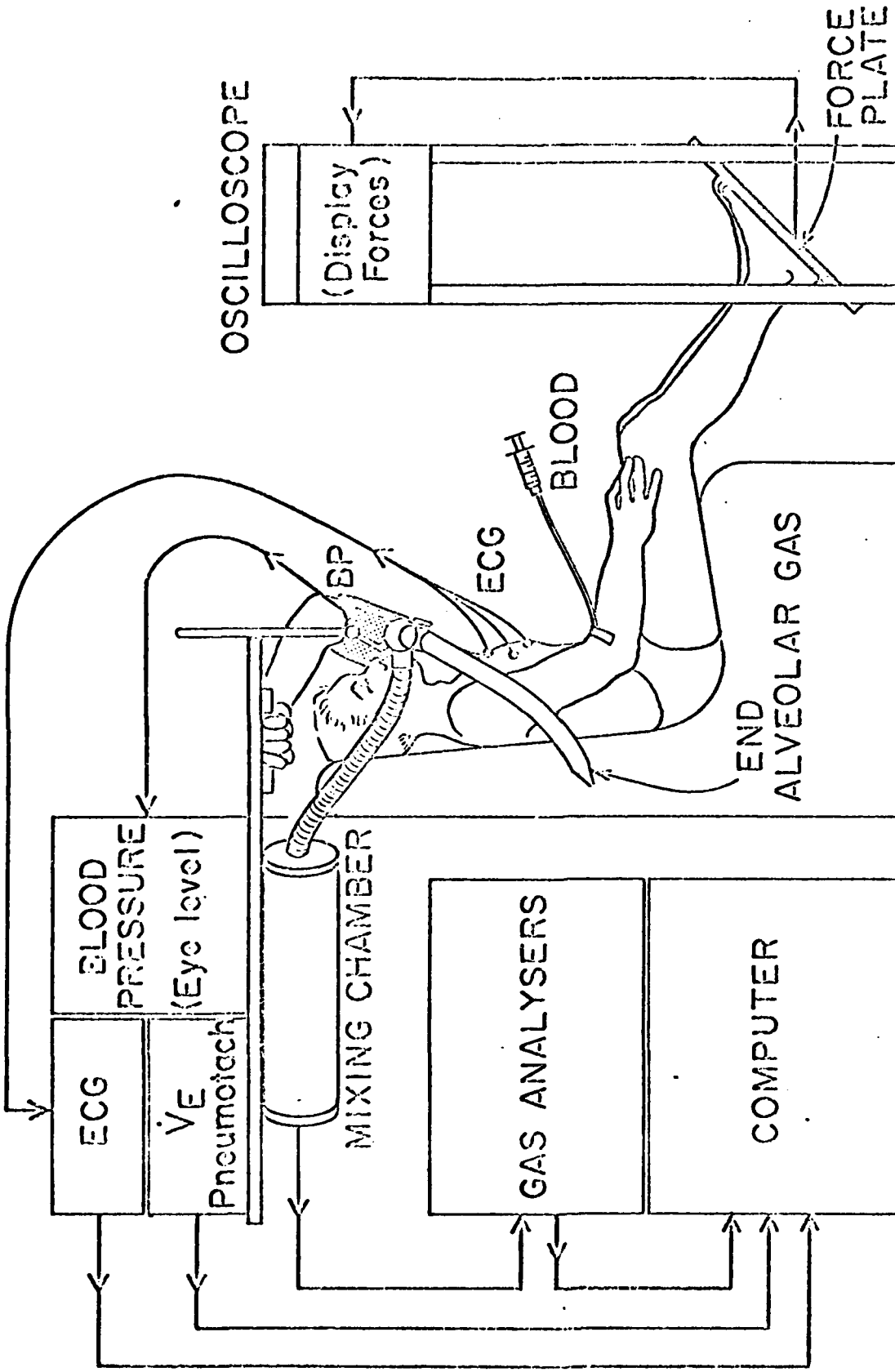
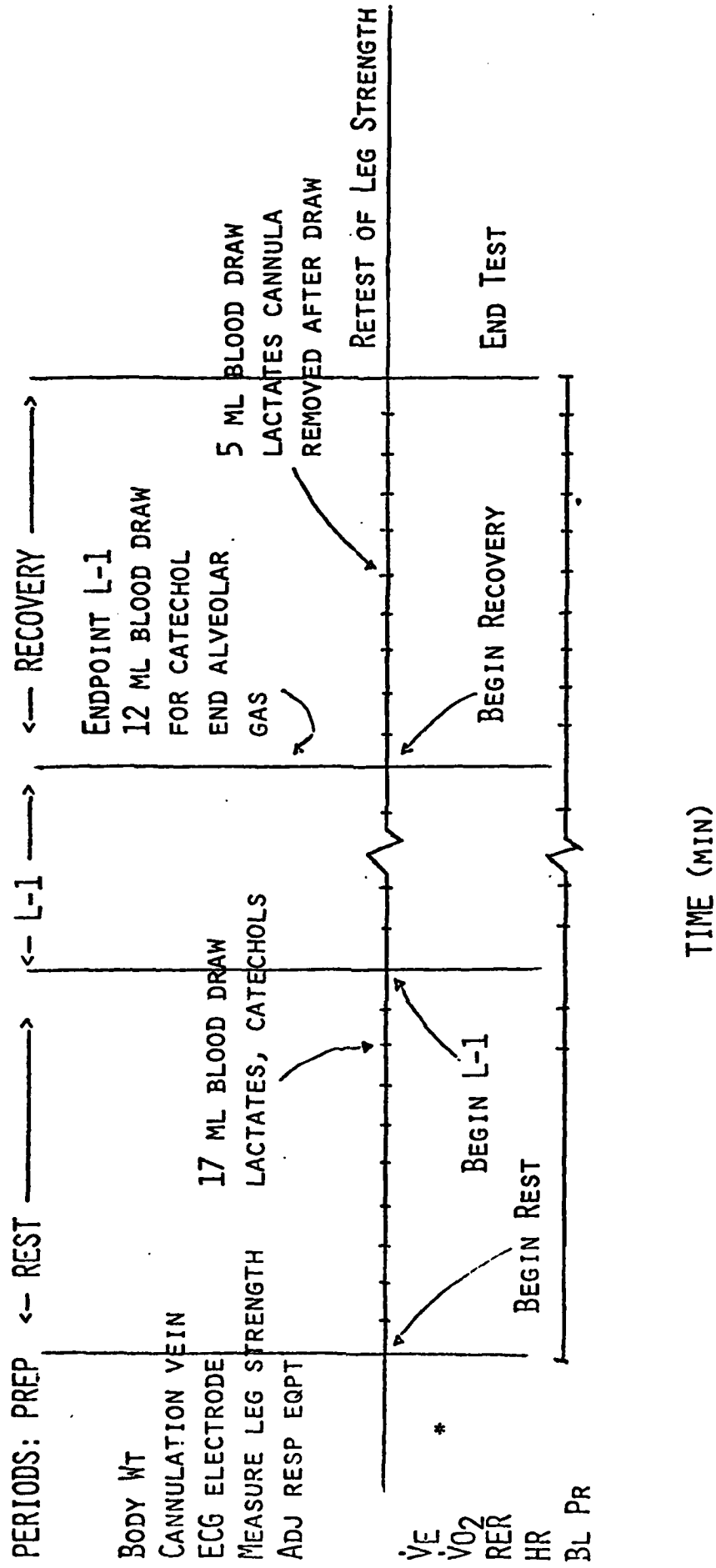

FIGURE 1. THE EXPERIMENTAL CONFIGURATION FOR THE L-1 STRAINING MANEUVER

FIGURE 2. EXPERIMENTAL PROTOCOL L-1 STRAINING MANEUVER



*ON-LINE 15 SEC INTERVALS

TABLE 1

SUMMARY OF SUBJECTS ANTHROPOMETRIC & PHYSIOLOGY CHARACTERISTICS

Sub.	Body Weight (kg)	Body Fat (%)	Lean Body Mass (kg)	Max Leg Extension (lbs)	$\dot{V}O_2$ max ($ml\ kg^{-1}\ min^{-1}$)	Resting Heart Rate (b/min)	Resp Power (mm Hg)
F.C.	76.6	11.9	68.0	216	60.3	45	186
A.C.	90.36	13.2	78.5	187	45.1	50	150
N.D.	66.3	9.0	60.3	115	66.8	53	184
R.H.	84.4	7.6	78.0	223	55.3	47	176
J.H.	94.6	19.2	76.4	209	50.7	72	128
G.M.	68.18	6.1	64.0	115	64.3	45	114
E.B.	79.	25.1	58.7	126	40.1	72	200
M.C.	62.4	9.6	56.4	150	69.6	41	160

TABLE 2. Body Size, Composition and Metabolic Characteristics of Subjects

Subject	Age	Height (cm)	Weight (kg)	% Body Fat	Blood Volume (ml)	Aerobic $\dot{V}O_2$ max (ml kg ⁻¹ m ⁻¹)
E.B.	52	168	72.1	20.6	4506	41.2
*F.C.	27	188	76.6	11.9	6298	61.2
*A.C.	33	191	84.1	12.0	6214	55.1
N.D.	25	165	66.0	9.0	7421	66.8
R.H.	24	187	84.4	7.6	7706	51.5
*J.H.	30	180	88.6	19.0	7716	59.3
*G.M.	25	180	68.2	8.0	7347	65.2
D.S.	22	178	70.0	10.0	--	65.1
\bar{x}	29.8	179.6	76.3	12.3	6672.6	58.2
S	9.6	9.3	8.5	4.9	1113.0	8.7

*Low tilt tolerance (fainters); high endurance capacity

TABLE 3. Strength Characteristics of Subjects

<u>Subject</u>	<u>Respiratory Power (mmHg)</u>	<u>Shoulder (lb)</u>	<u>Trunk Curl (sec)</u>	<u>Dynamic Arm Strength (RPI)</u>	<u>Dynamic Leg Strength (RPM)</u>
E.B.	192	88	49.4	87	121
*F.C.	186	105	58.4	94	125
*A.C.	150	112	45.0	89	124
N.D.	184			75	108
R.H.	176	140	48.1	82	128
*J.H.	128	93	42.5	88	122
*G.M.	114	112	31.1	92	138
D.S.	168	120	71.4		150
\bar{x}	162.2	110.0	49.4	86.7	127.0
S	28.8	17.3	13.9	6.4	12.5

*Endurance Trained Individuals and Fainters When Exposed to 70° Head-Up Tilt.

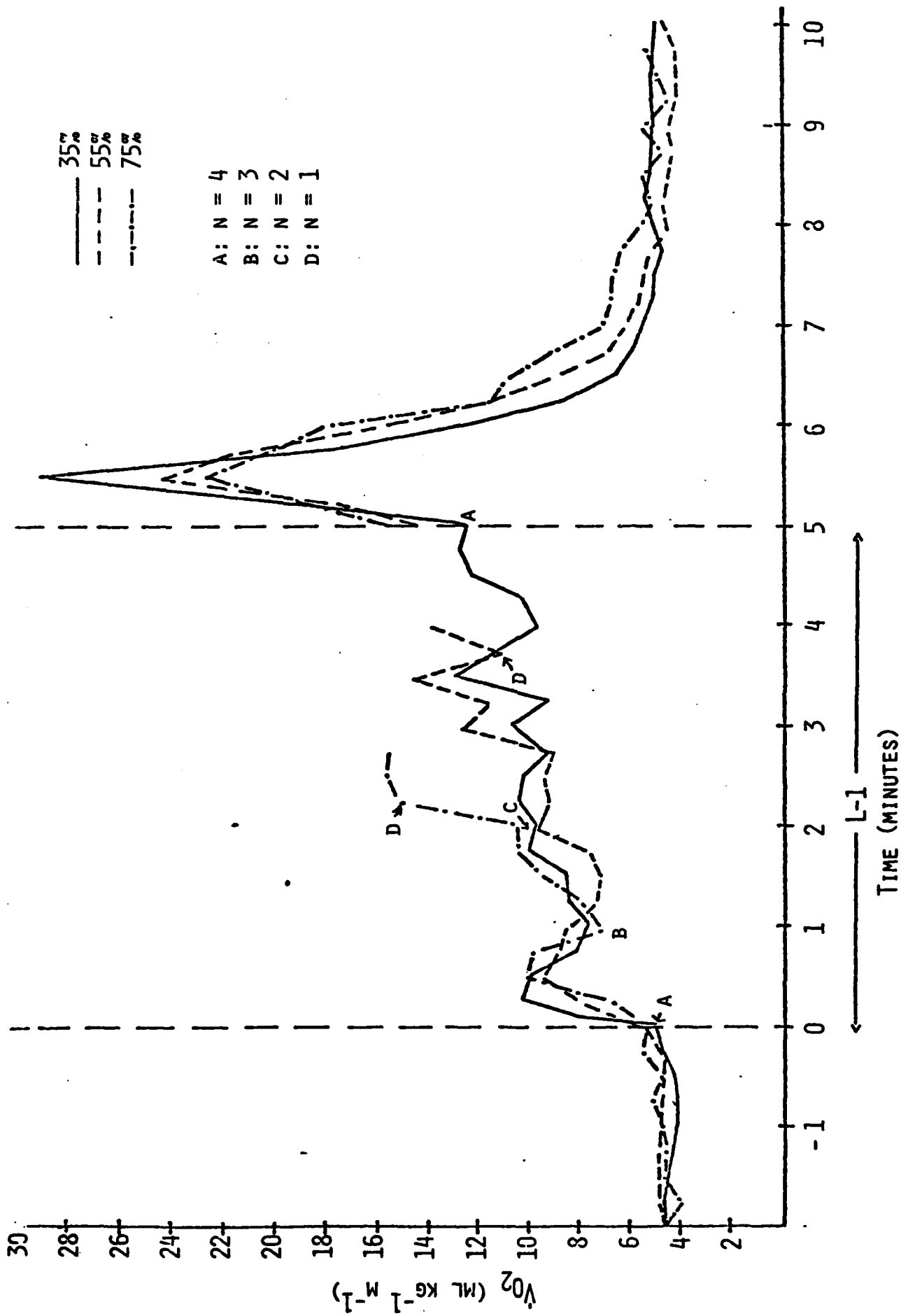

FIGURE 3. $\dot{V}O_2$ RESPONSE BEFORE, DURING AND FOLLOWING L-1 MANEUVER

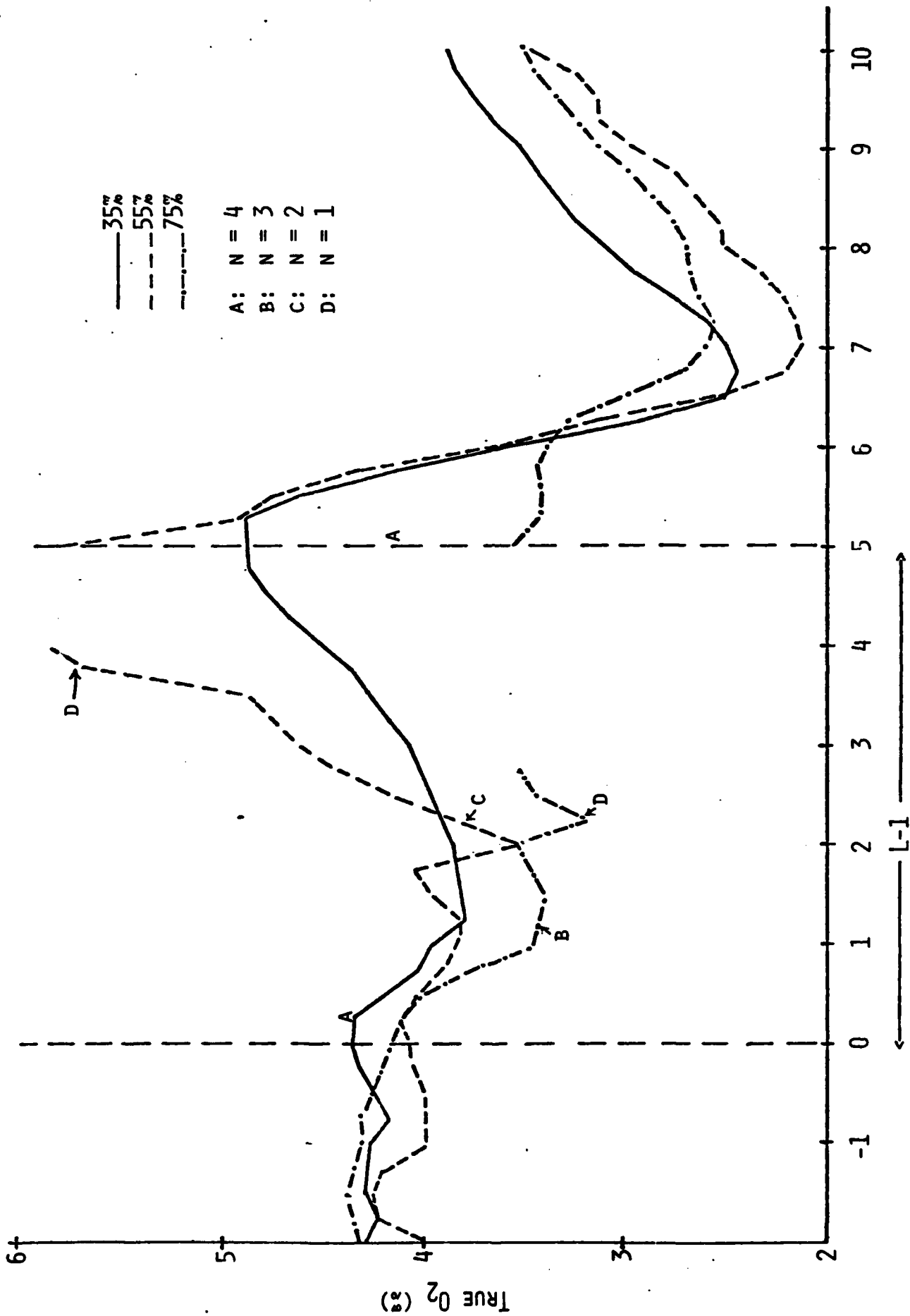

FIGURE 4. OXYGEN EXTRACTION RESPONSE BEFORE, DURING AND FOLLOWING L-1 MANEUVER

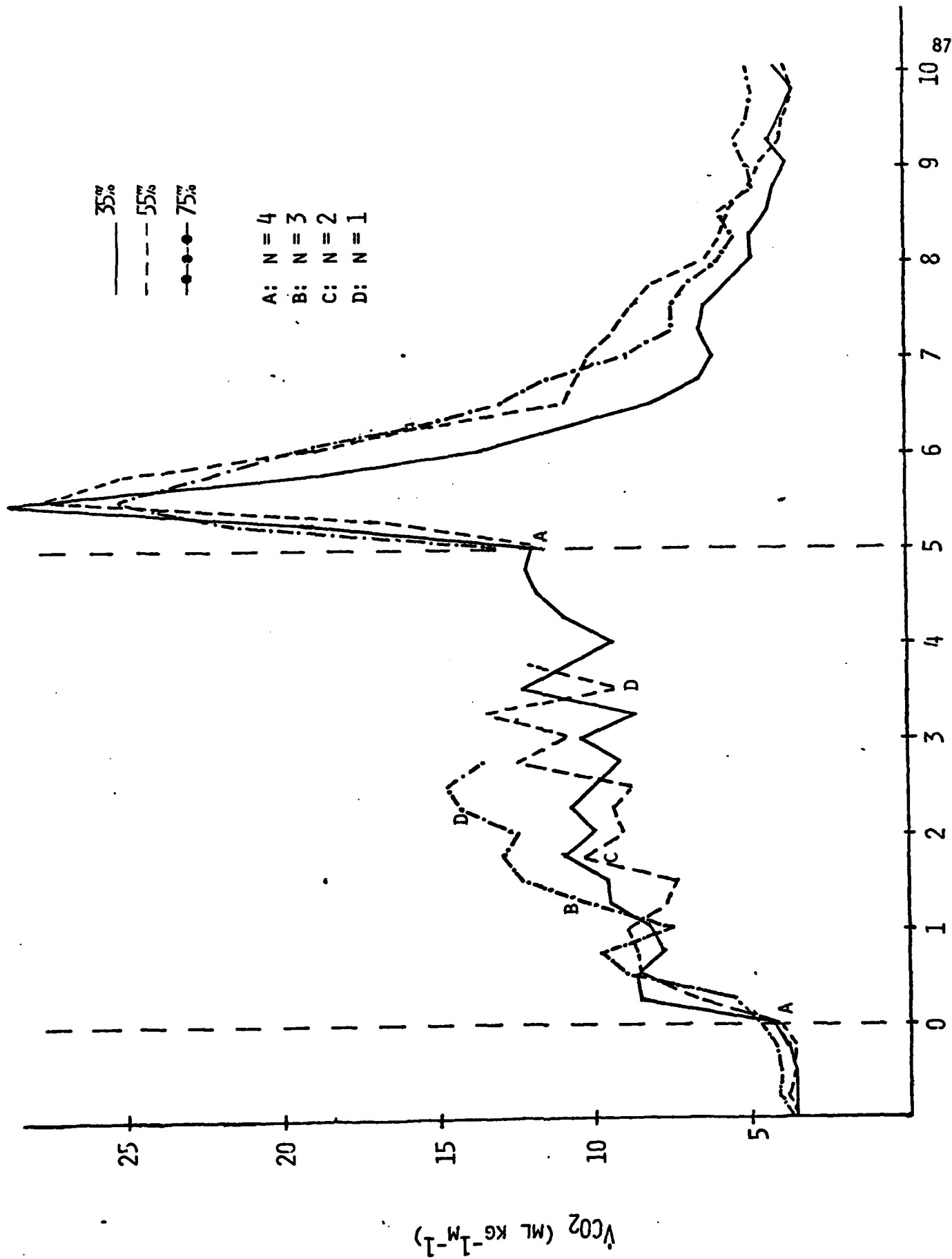

FIGURE 5. $\dot{V}CO_2$ RESPONSE BEFORE, DURING AND FOLLOWING L-1 MANEUVER

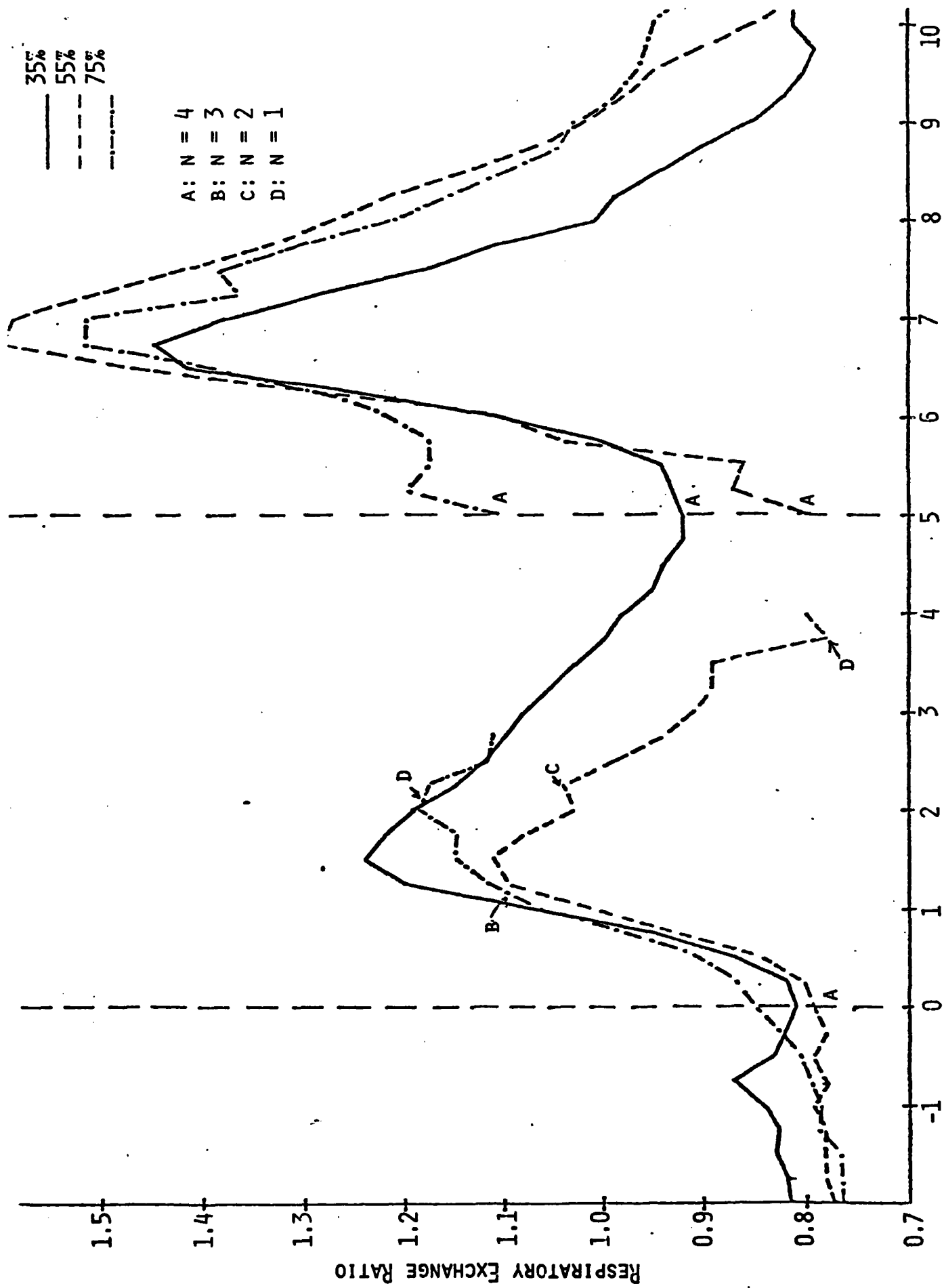

FIGURE 6. RESPIRATORY EXCHANGE RATIO (RER) BEFORE, DURING AND FOLLOWING L-1 MANEUVER

TABLE 4. Aerobic-Anaerobic Responses of Subjects to L-1 Maneuver Performed at 35, 55 and 75% of max Leg Strength: Group II Experimental Subjects

Subject	O ₂ Intake (L)		(C) Total O ₂ Cost (L)	(D) Duration of L-1 (min)	(E) L-1 $\dot{V}O_2$ (L/min)	(F) Aerobic Fraction (%)
	(A) L-1	(B) Post L-1				
	0'-2' 0'-5'					
			35%			
E.B.	2.86	1.84	4.58	5:00	0.92	62
A.C.	1.30	0.44	1.86	5:00	0.37	70
J.H.	2.09	1.60	3.52	5:00	0.70	59
D.S.	2.51	1.21	4.16	5:00	0.83	60
\bar{x}				5:00	0.71	62.75
S					0.24	4.99
			55%			
E.B.	1.96	1.36	3.26	3:30	0.99	60
A.C.	1.48	1.28	2.97	4:00	0.74	50
J.H.	0.42	2.12	2.03	2:00	1.02	21
D.S.	0.69	1.76	2.69	2:00	1.35	26
\bar{x}				2:53	1.02	39.25
S				1:02	0.31	18.75
			75%			
E.B.	1.65	2.27	4.53	2:45	1.84	36
A.C.	0.50	1.41	1.89	2:00	0.95	26
J.H.	0.72	1.83	2.53	2:00	1.27	23
D.S.	0.20	1.10	1.43	1:00	1.43	14
\bar{x}				1:56	1.37	26.00
S				43.2	0.32	9.09

TABLE 5. Lactic Acid Values Pre-Post L-1 Maneuver
at Three Levels of Leg Strength

% Max Leg Extension		Blood Lactate Level (mg 100 ml ⁻¹)		N
		Pre	Post	
35	\bar{x}	14.89	33.67	3
	S	2.64	13.11	
55	\bar{x}	14.75	44.14	4
	S	2.24	20.95	
75	\bar{x}	17.08	33.80	3
	S	6.66	4.07	

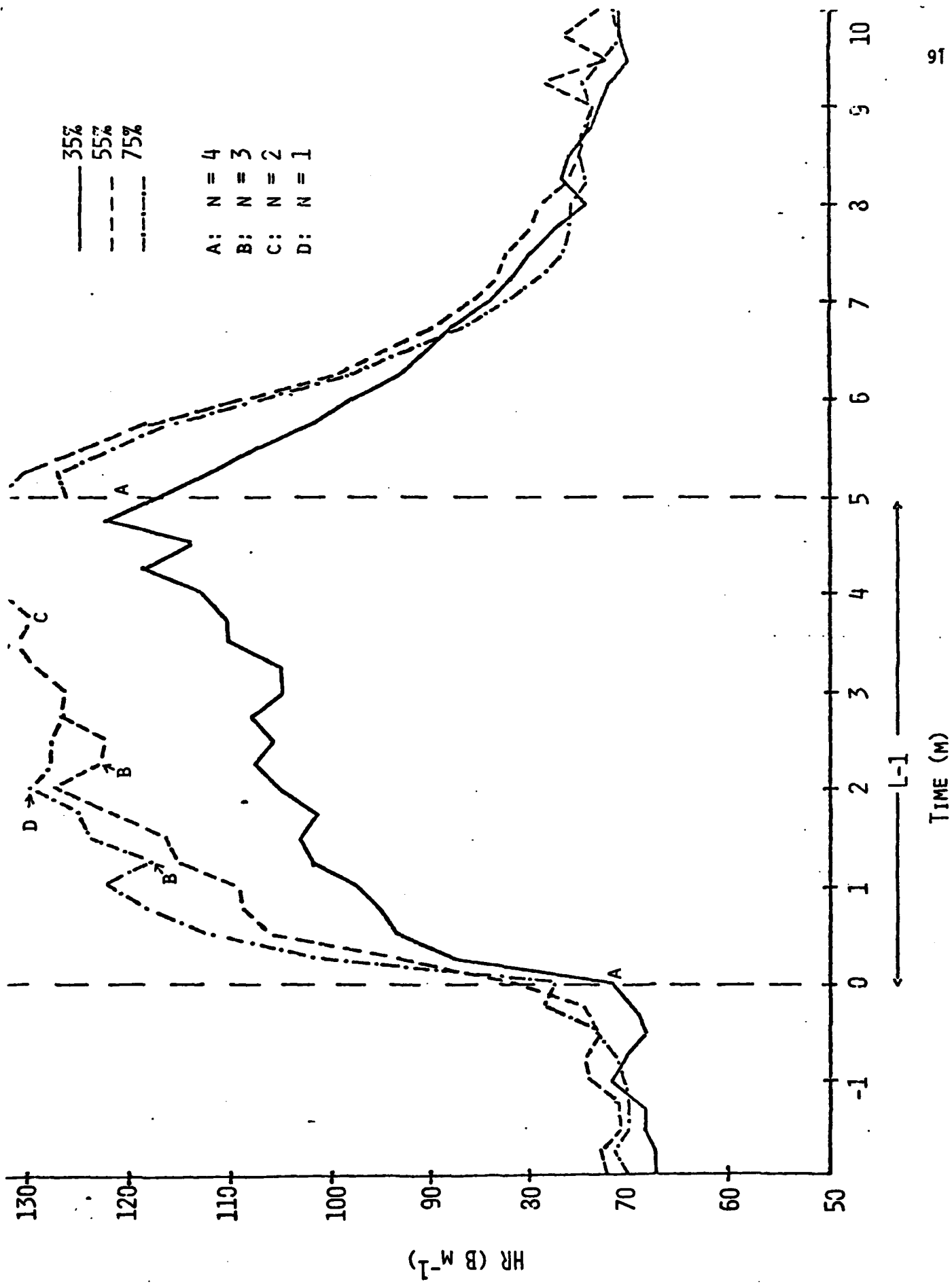

FIGURE 7. HEART RATE RESPONSE BEFORE, DURING AND FOLLOWING L-1 MANEUVER

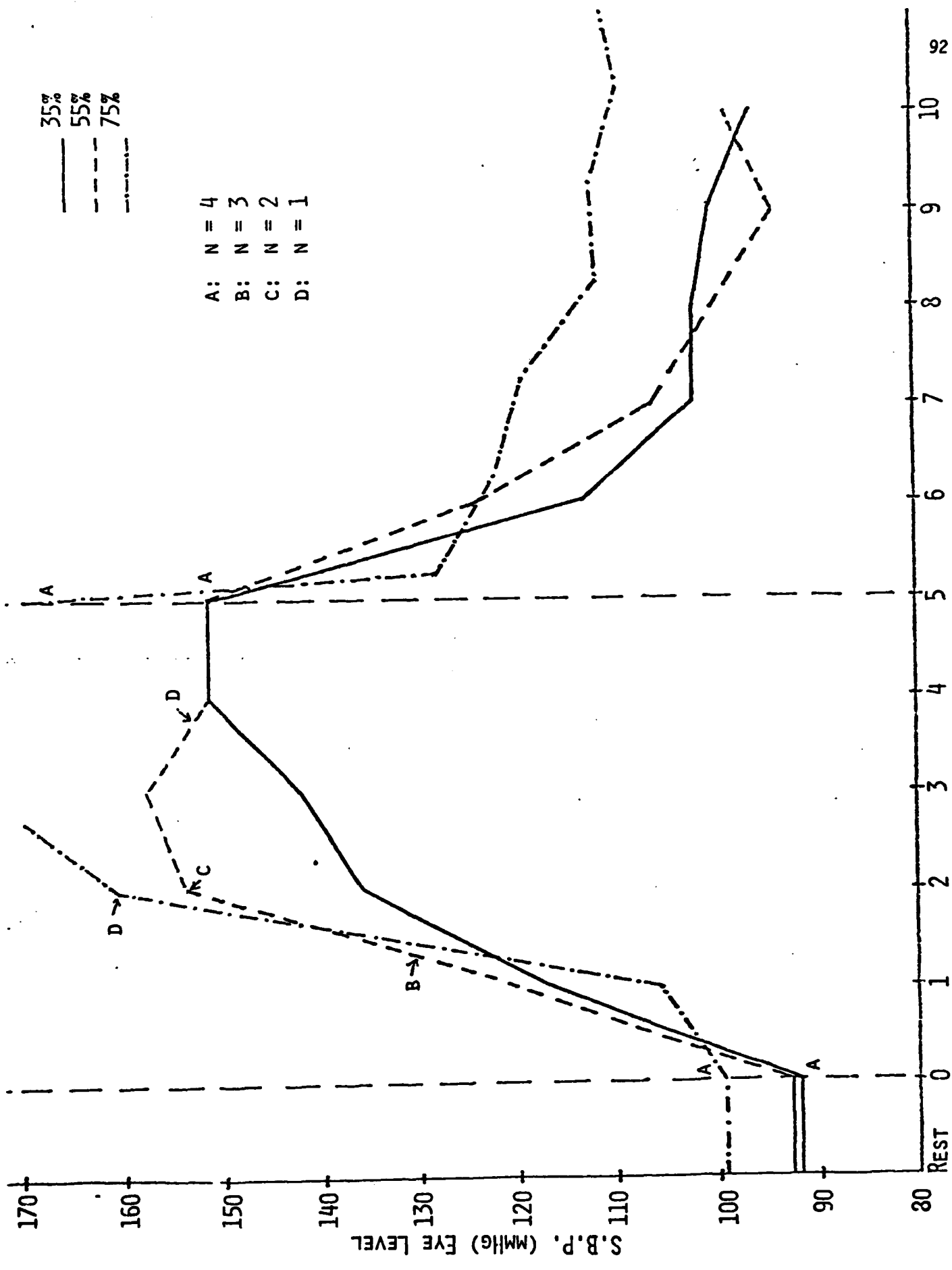

FIGURE 8. SYSTOLIC BLOOD PRESSURE RESPONSE BEFORE, DURING AND FOLLOWING L-1 MANEUVER

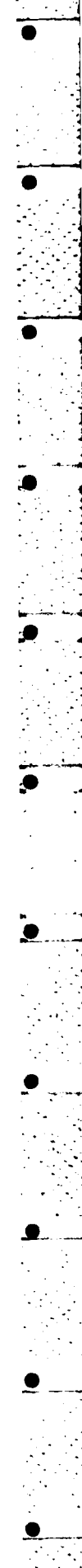
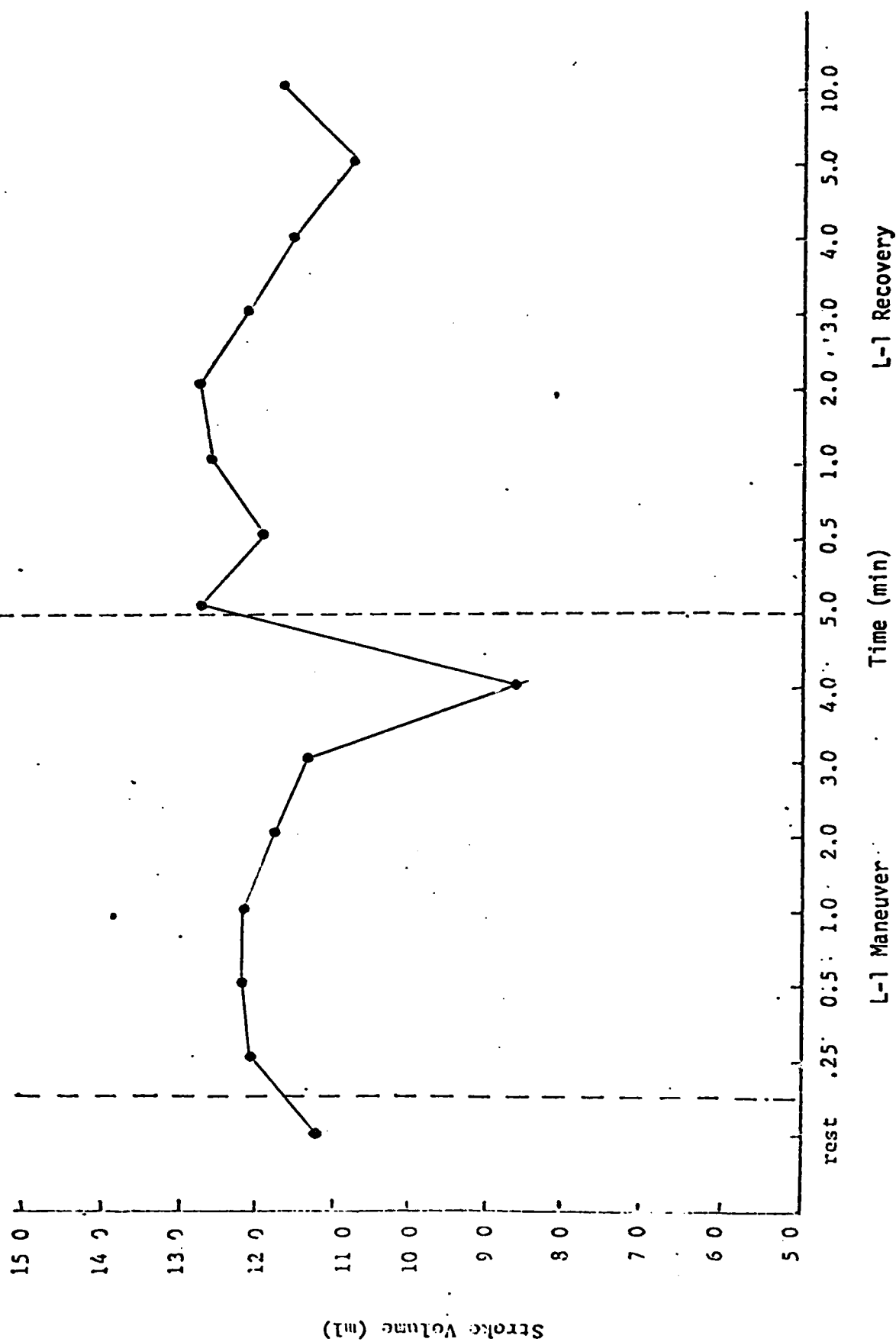
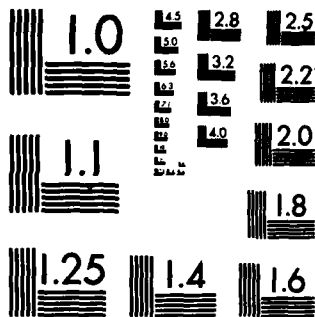

FIG. 9. AVERAGE STROKE VOLUME RESPONSE BY ECHOCARDIOGRAPHY TO 5-MIN SUSTAINED ISOMETRIC LEG CONTRACTION AND L-1 MANEUVER PERFORMED AT 55% MAX LEG STRENGTH





MICROCOPY RESOLUTION TEST CHART
NATIONAL BUREAU OF STANDARDS-1963-A

FIG. 10. AVERAGE CARDIAC OUTPUT RESPONSE BY ECHOCARDIOGRAPHY TO 5-MIN SUSTAINED ISOMETRIC LEG CONTRACTION AND L-1 MANEUVER PERFORMED AT 55% MAX LEG STRENGTH

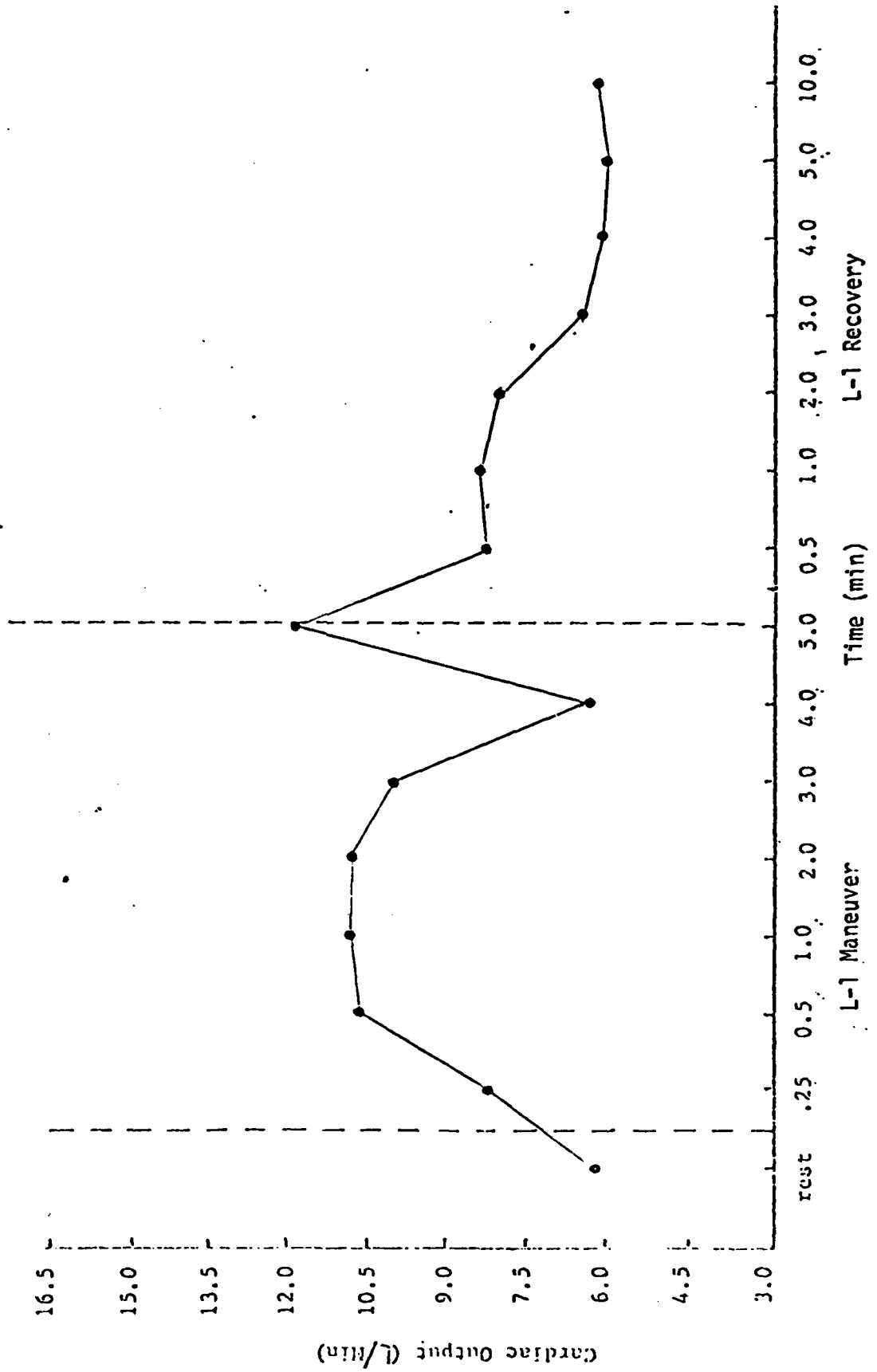
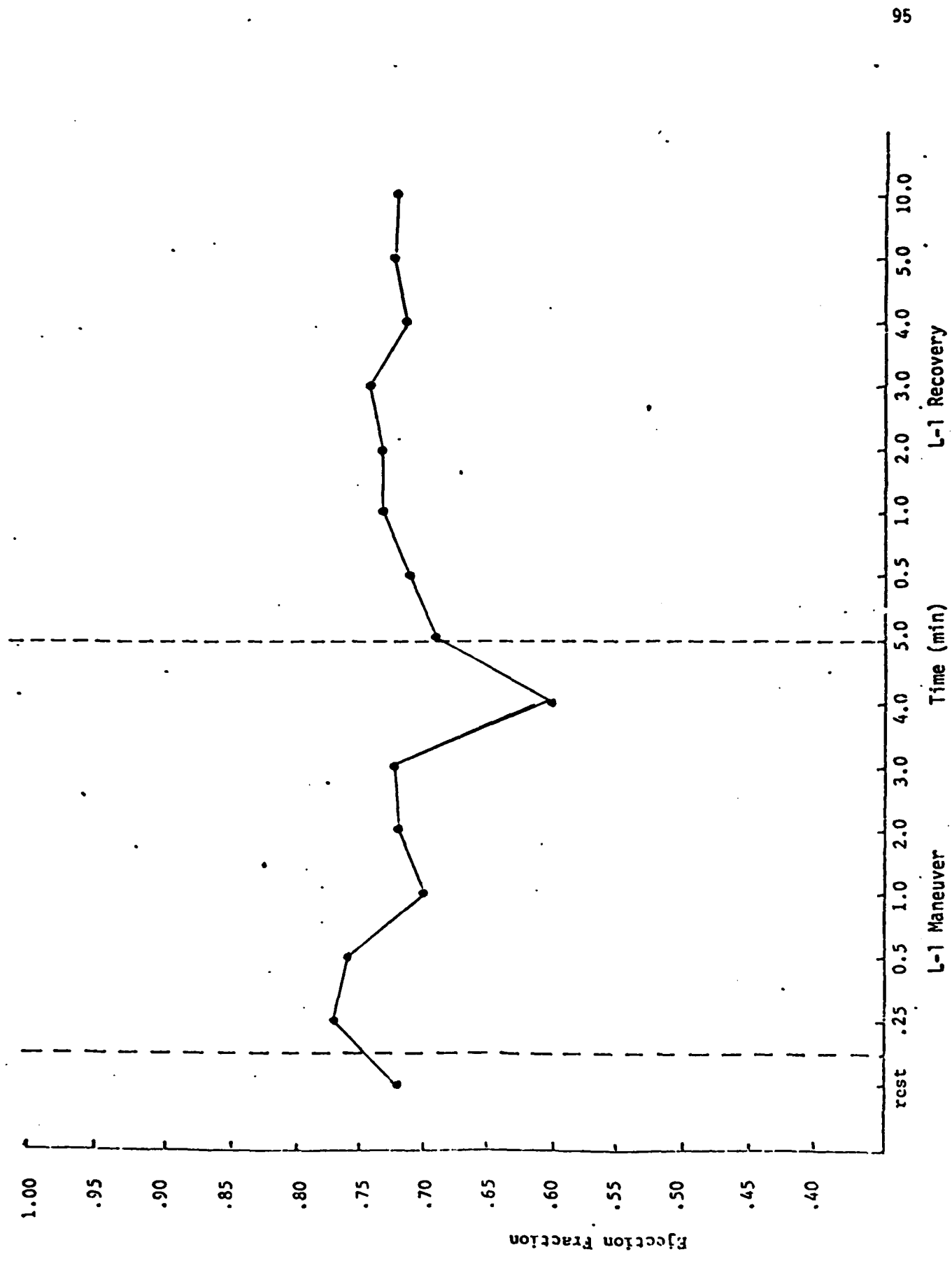
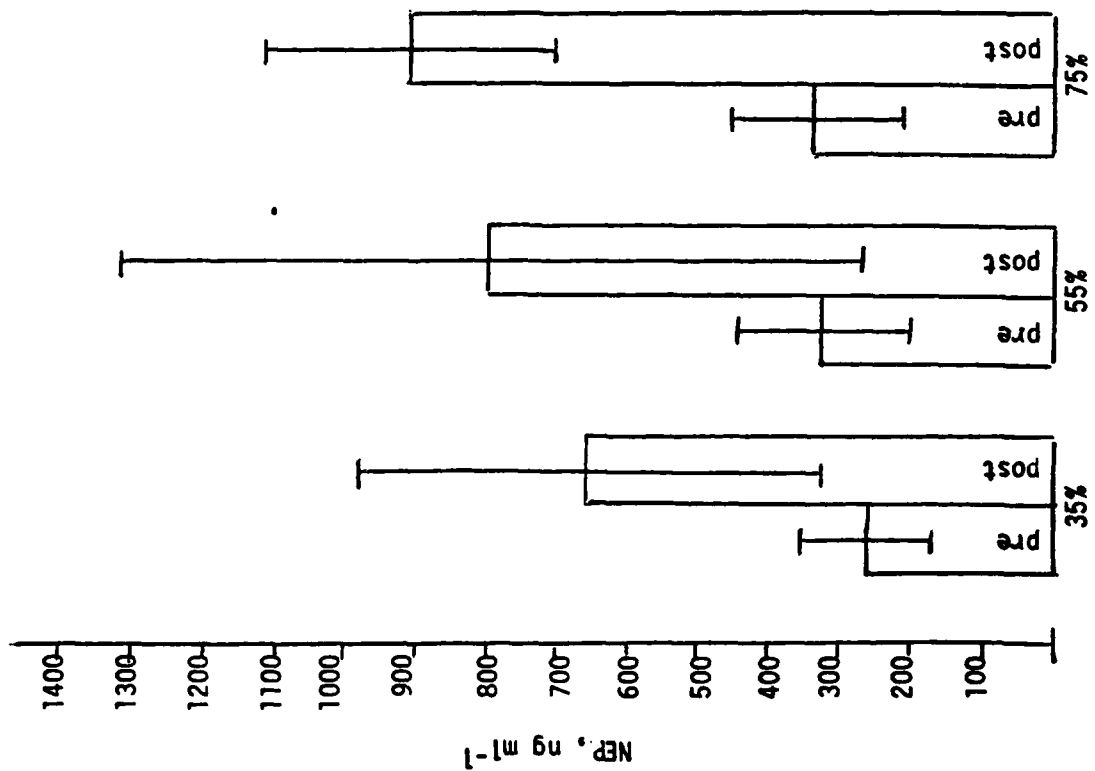
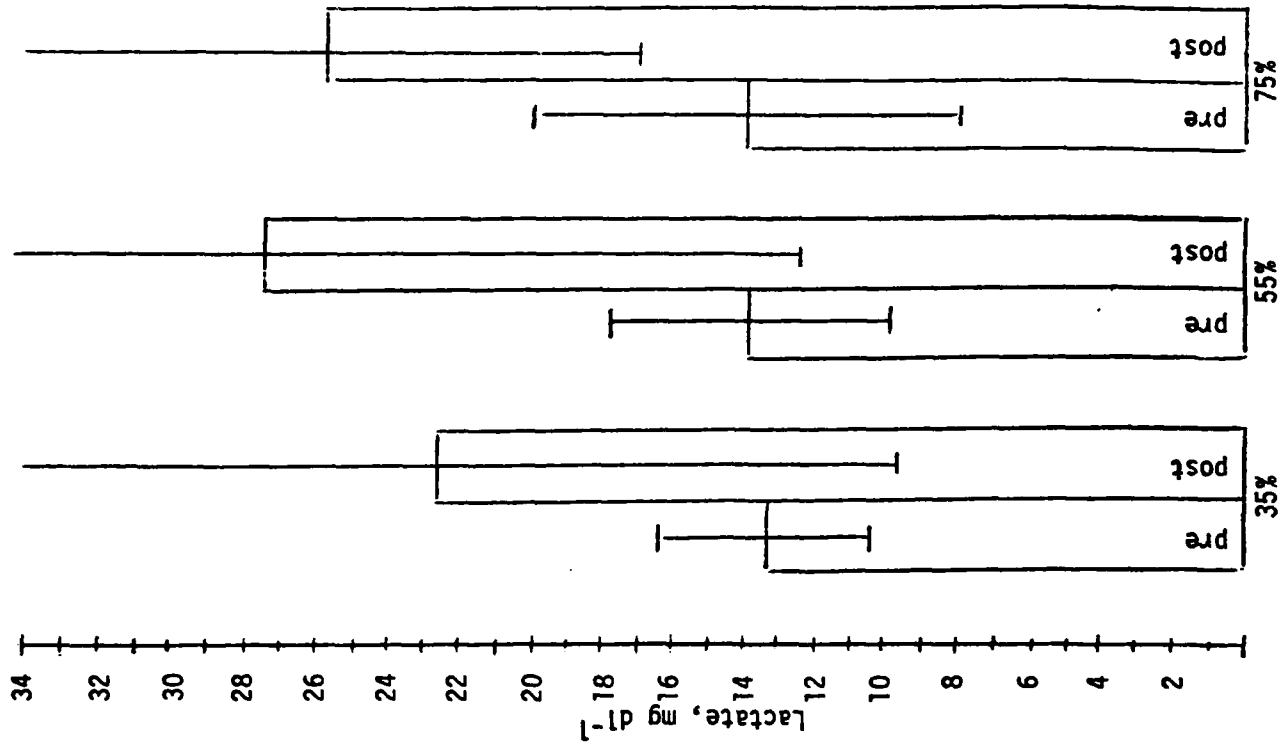

FIG. 11. EJECTION FRACTION RESPONSE BY ECHOCARDIOGRAPHY TO 5-MIN SUSTAINED ISOMETRIC LEG CONTRACTION AND L-1 MANEUVER PERFORMED AT 55% MAX LEG STRENGTH





Time (min) 5:00 2:53 1:56

FIGURE 12. NorEpi and lactate concentrations in venous blood pre and post graded straining maneuver @ one gravity 96

B-2 Orthostatic Tilt Tolerance of Fainters vs. Non Fainters Characterized
by Anthropometric and Cardiovascular Parameters:

by

Glen Mangseth

&

Ed Bernauer

INTRODUCTION

Over the last several months our lab has been involved in studying orthostatic tolerance as related to body somatotype and physical condition. Stegemann et. al. has presented data suggesting that blood pressure regulation in the endurance trained athlete is not as efficient as that in the sedentary individual. We have been interested in exploring this further by examining cardiovascular response to head-up, saddle supported, passive tilt in a spectrum of people varying from sedentary to highly trained endurance runners.

EXPERIMENTAL PROCEDURES

The experimental set-up is illustrated in Figure 1. The subject is instructed to lay supine on a modified x-ray table which can be manually tilted to any desired angle. The subject is supported while tilted by a pneumatic saddle. Stroke volume and cardiac output are estimated from chest impedance changes using an IFM Minnesota Impedance Cardiograph. Calf impedance change during tilt is monitored with a similar unit, this change being used for estimation of blood pooling in this region. Heart rate and blood pressure are monitored using a Physiograph-4 recorder equipped with automatic blood pressure cuff inflation and a microphone for monitoring Korotkoff sounds. The subject is supine for ninety minutes prior to tilt during which time he is attached to the various recording instruments. Ten minutes prior to tilt data acquisition is begun. The subject is then tilted to an angle of 70° for a period of 1/2 hour or until fainting appears imminent as judged by subject determined loss or greying of peripheral vision. During the course of the experiment cardiac output is monitored approximately every two minutes, blood pressure is determined every thirty seconds and heart rate and blood pooling are monitored continuously.

IMPEDANCE vs. CARDIAC DYE METHOD FOR CARDIAC OUTPUT MEASUREMENT

The use of Impedance measurements for the determination of cardiac output has met with some criticism. We have compared this technique with the cardiac green dye method for the determination of cardiac output. Four subjects were used in this comparison and cardiac output determinations were made with both methods during various postural maneuvers. Figure 2 indicates the relationship we found. As can be seen by the regression equation, the slope of the least squares line is very close to one and the line effectively goes through zero. The correlation coefficient is 0.82 which is significant as indicated. This data compares favorably with results obtained by Denniston et. al. who used much larger subject pool. The dashed line is the relationship his group found. As can be seen, the relationship appears to be of the same order as that obtained in our lab. The correlation coefficient is 0.90, indicating good agreement between the two methods. Because of this data, we feel fairly confident that the impedance technique is giving us useful information on cardiac output.

IMPEDANCE vs. WHITNEY STRAIN GAUGE FOR DETERMINATION OF BLOOD POOLING

We are also using impedance for the measurement of blood pooling in the limb and felt it necessary to validate it against an accepted technique. In this regard we have compared measurements of fluid pooling in the calf as measured with the Whitney strain gauge and the impedance technique. Figure 3

shows the results from experiments on four individuals who were tilted for varying lengths of time. As indicated by the slope of the least squares line, the Whitney strain gauge gives higher values for pooling as compared with the impedance method. Since it can be argued that neither method is absolute in its ability to measure tissue volume change, one should not place too much emphasis on this discrepancy. Of greater importance is the strong linear relationship between the two techniques. This tends to remove doubt as to what the impedance method measures and, we feel, makes it a valid technique for estimation of blood pooling.

SUBJECT CHARACTERISTICS

Eight subjects were characterized as fainters or non fainters using the tilt procedure. Four of the eight subjects experienced syncopal reactions while tilted as confirmed from heart rate and blood pressure recordings. These four individuals could be described as ectomorphic in body type and endurance trained. As seen in Table 1 the mean maximal oxygen consumption of this group was 66.8 ml/kg body weight, the mean resting heart rate was 47 beats per minute and body composition analysis indicated an average 8.28% fat.

In contrast, the four non-fainters varied in degree of fitness as measured by maximal oxygen consumption but could be generally characterized as moderately fit with a group mean maximal oxygen consumption of 52 ml/kg. Mean resting heart rate was 55.5 beats/minute and body composition analysis showed a mean % fat of 13.98. All were mesomorphic in body type.

RESULTS

Figure 4 shows the cardiac output response to tilt of the two groups. They are means for each group derived from several determinations prior to syncope or prior to the end of the thirty minute tilt period for each individual. The bars represent standard deviations for each sample. As can be seen there is no significant difference between the two groups in resting or tilted values of cardiac output. The non fainters show a significant reduction in cardiac output while the fainters demonstrate a slight decline, not significant owing to the small number of subjects.

Stroke volumes were similar in both groups at rest and during tilt as seen in Figure 5. Significant reductions in stroke volume occurred in both groups, and these were of similar degree, averaging approximately a 43% reduction from the resting values.

Heart rates (see Figure 6) of the non fainters appeared to be higher than the fainters both during rest and while tilted, although these measured differences were not statistically significant. The fainters were able to increase heart rate significantly over resting values while tilted. This was not the case with non fainters. This difference appears to account for the relatively small reduction in cardiac output in fainters as compared with non fainters.

On the left of bar graph presented in Figure 7 is shown the maximal amount of blood pooled in the calf during tilt of both groups. On the right we have abdominal pooling measurements obtained in a recent set of experiments on four subjects. Although not significantly different, it appears that blood pooling

is greater in the non fainters, probably a reflection of the longer period of time they remained tilted. At equivalent times, fainters and non fainters pool similar amounts of blood.

Figure 8 shows the response of mean arterial pressure in both groups. Non fainters were able to significantly increase mean arterial pressure even in the face of a declining cardiac output. This suggests a profound ability to increase total peripheral resistance. On the other hand, the fainters demonstrated a rather flat response, maintaining mean arterial pressure at levels slightly greater than resting.

Figure 9 shows the manner in which TPR changed upon tilting in the two groups. Pre tilt and tilted values are not significantly different between the two groups. The non fainters were able to raise TPR significantly over resting values, while the fainters could not. As we saw in Figure 8, this difference is likely responsible for the significant increase in MAP demonstrated by the non fainters but not by the fainters.

CONCLUSION

In conclusion, it would appear that the ectomorphic, endurance trained individual is more inclined to syncopal reaction during orthostatic hypotension induced by head-up tilting than is the mesomorphic, moderately trained subject. This syncopal response does not appear to be related to inordinate blood pooling in dependent body regions and a consequent reduction in cardiac output, as non fainters experienced equal or greater changes in these parameters during 1/2 hour of tilt yet showed no signs of an impending syncopal reaction.

This conclusion agrees with that of Stead and Ebert (1941) who studied a group of patients with postural hypotension and that of Lind et. al. (1968) who studied a population men prone to syncope in a hot environment.

A major difference in the two groups observed lay in the regulation of TPR. The non fainters were much more adept at increasing this parameter, to the extent that MAP was increased even in the face of a falling cardiac output. The inability of the fainters to increase blood pressure and TPR to the same extent as the non fainters supports Stegemann's contention that the gain of the blood pressure regulating system in the endurance athlete is less than his sedentary counterpart. Klein et. al. has found a positive correlation between resting blood pressure and $+G_z$ tolerance. This would imply that the endurance trained individual may be less suited to withstand $+G$ acceleration.

The increase in TPR is thought to be due to vasoconstriction in muscle, skin, splanchnic and other organ vascular beds. Brigden, Howarth and Sharpey-Schafer (1950) have shown that the drop in blood pressure with fainting is associated with a vasodilation and increase in blood flow in forearm musculature. Similar results have been obtained by Barcroft and Edholm after removal of blood from subjects by venesection. Thus, syncope appears to be related to a precipitous drop in TPR. Barcroft and Edholm suggest such a drop to be related to activity of the vasomotor nerves. If that is the case, we could postulate a major difference in neural control of the peripheral vasculature in the endurance trained individual.

Another possibility exists. TPR can be reduced by a decline in vasomotor

tone or it can be reduced via functional sympatholysis as occurs in exercise. Endurance runners would appear to have more aerobic musculature as compared to most individuals. Folkow and Halicka (1958) and Hudlicka (1975) have all shown there to be a significant difference in blood flow regulation in red vs. white muscle at rest and during exercise. Hilton and Chir (1971), Hilton and Vrbova (1970) and Hilton and Hudlicka (1971) have found differences in local metabolic control of vascular resistance in aerobic vs. anaerobic muscle. It may be that during tilt, even a small increase in vascular resistance and reduction in blood flow to highly aerobic skeletal muscle may result in vasodilator metabolite build-up, leading to a functional sympatholysis and an acute decline in TPR.

If true, this has obvious implications with respect to the type of training program which would be most effective in increasing $+G_z$ tolerance. Weight lifting, or some other relatively anaerobic training program that would stimulate a shift in muscle fiber characteristics to the more anaerobic side of the spectrum might be expected to increase orthostatic $+G_z$ tolerance by avoiding the functional sympatholysis phenomenon.

Heart Rate

Blood Pressure

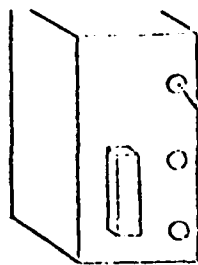

Chest Impedance
I. Cardiac output
Stroke volume
estimation

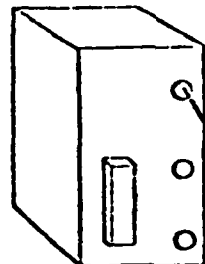

Limb Impedance for:
I. Estimation of fluid
pooling

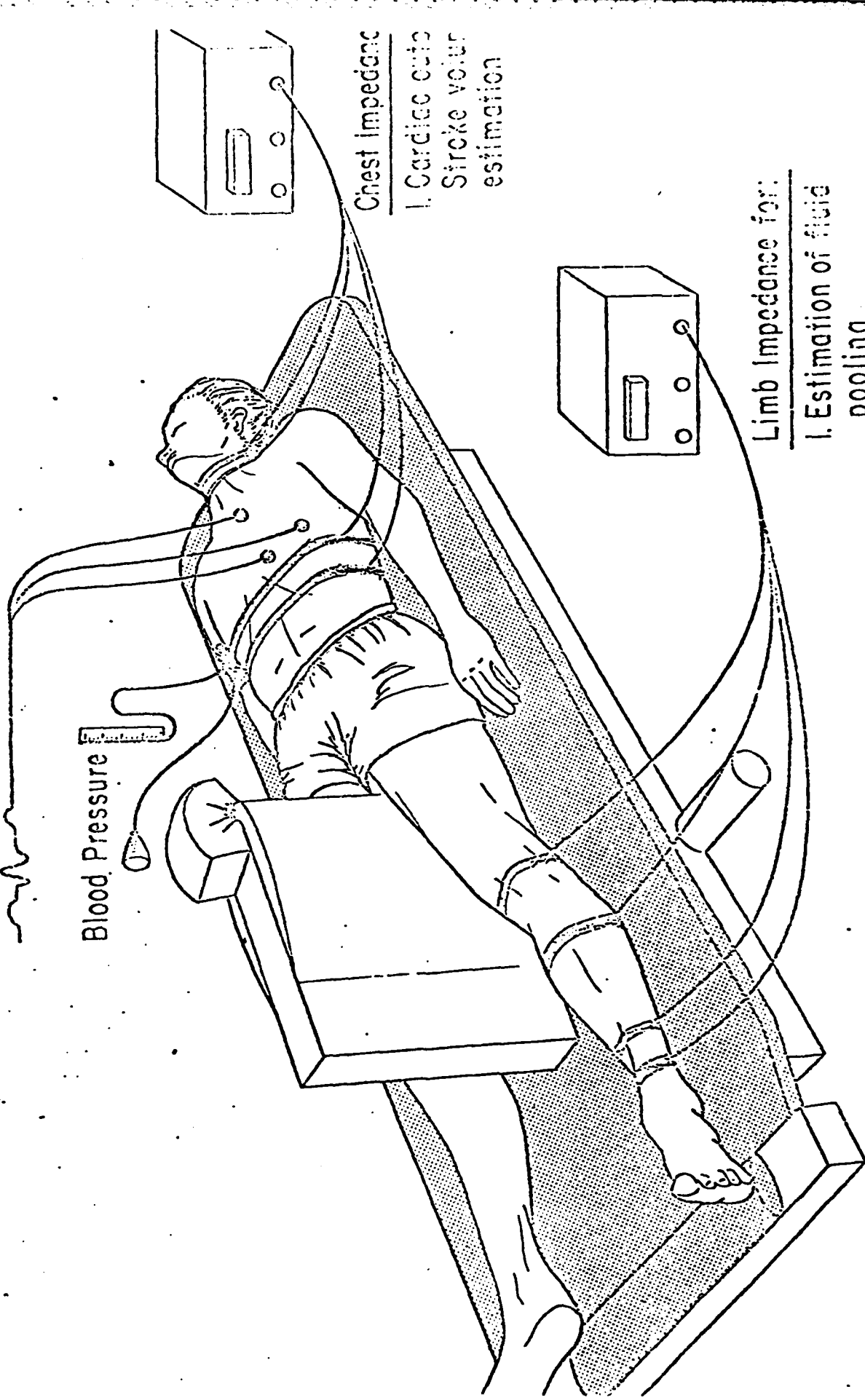
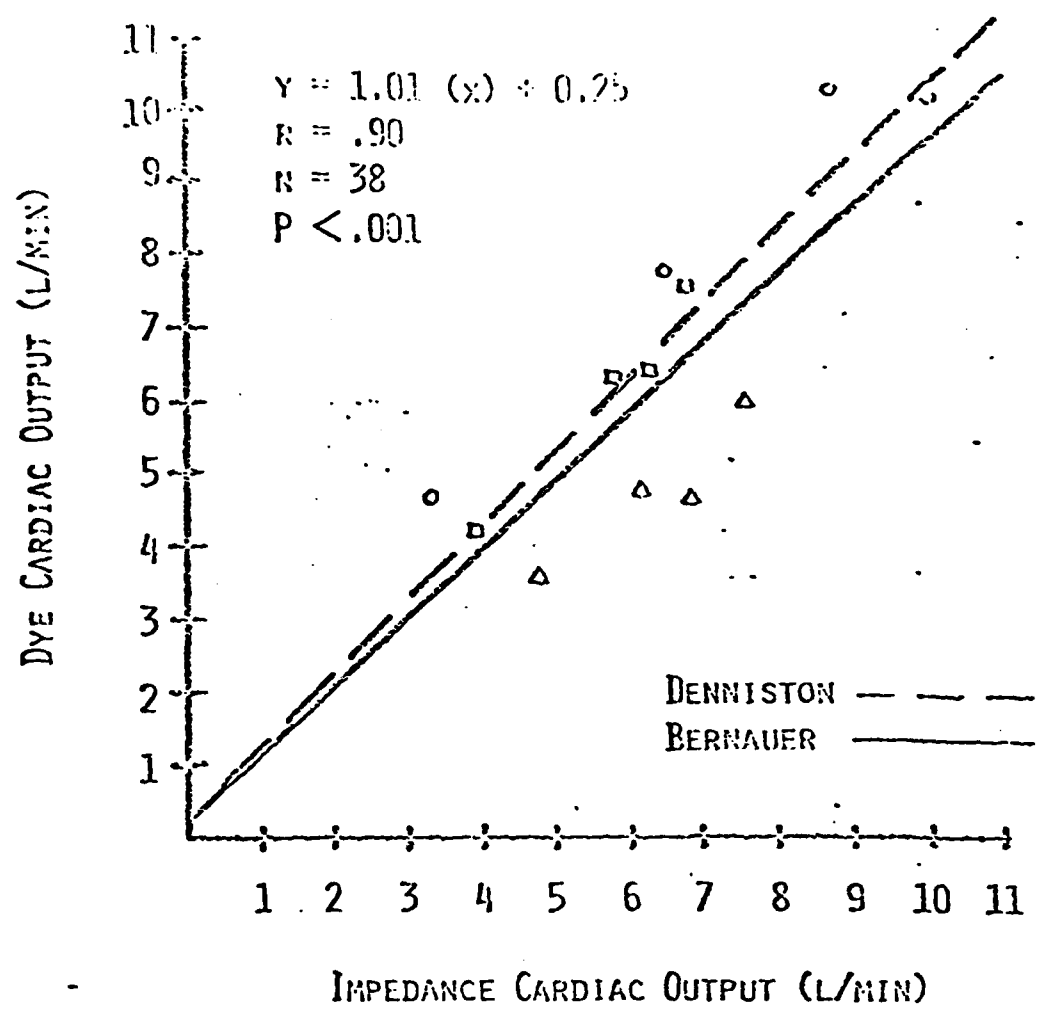

Figure 1.



Y = .96 (x) + .27
R = .82
N = 12
P = < .01

O SUPINE
Δ STANDING
□ SITTING

Figure 2.

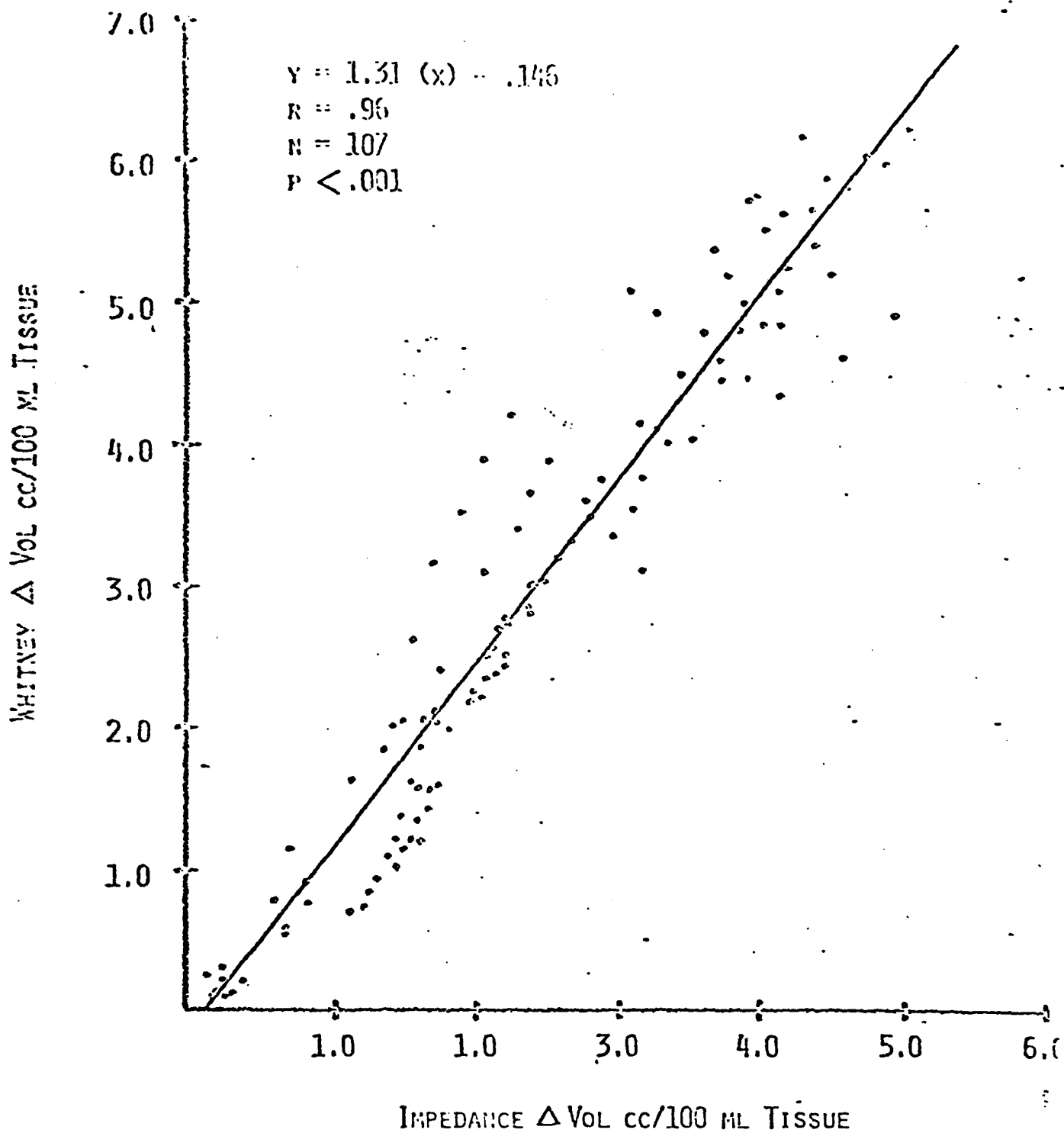

Figure 3.

SUBJECT CHARACTERISTICS

FAINTERS

SUBJECT	V _{O2} MAX (ML/KG)	RESTING HR (B/M)	% FAT
F.C.	60.3	45	11.9
G.M.	64.3	45	6.1
M.C.	69.6	41	9.6
P.H.	73.0	55	5.5
$\bar{x} \pm$ S.D.	66.8 ± 5.62	46.5 ± 5.97	8.28 ± 3.02

NONFAINTERS

A.C.	45.1	50	13.2
N.D.	66.8	53	9.0
R.H.	55.3	47	7.6
E.B.	40.8	72	26.1
$\bar{x} \pm$ S.D.	52 ± 11.59	55.5 ± 11.27	13.98 ± 8.43

Table 1.

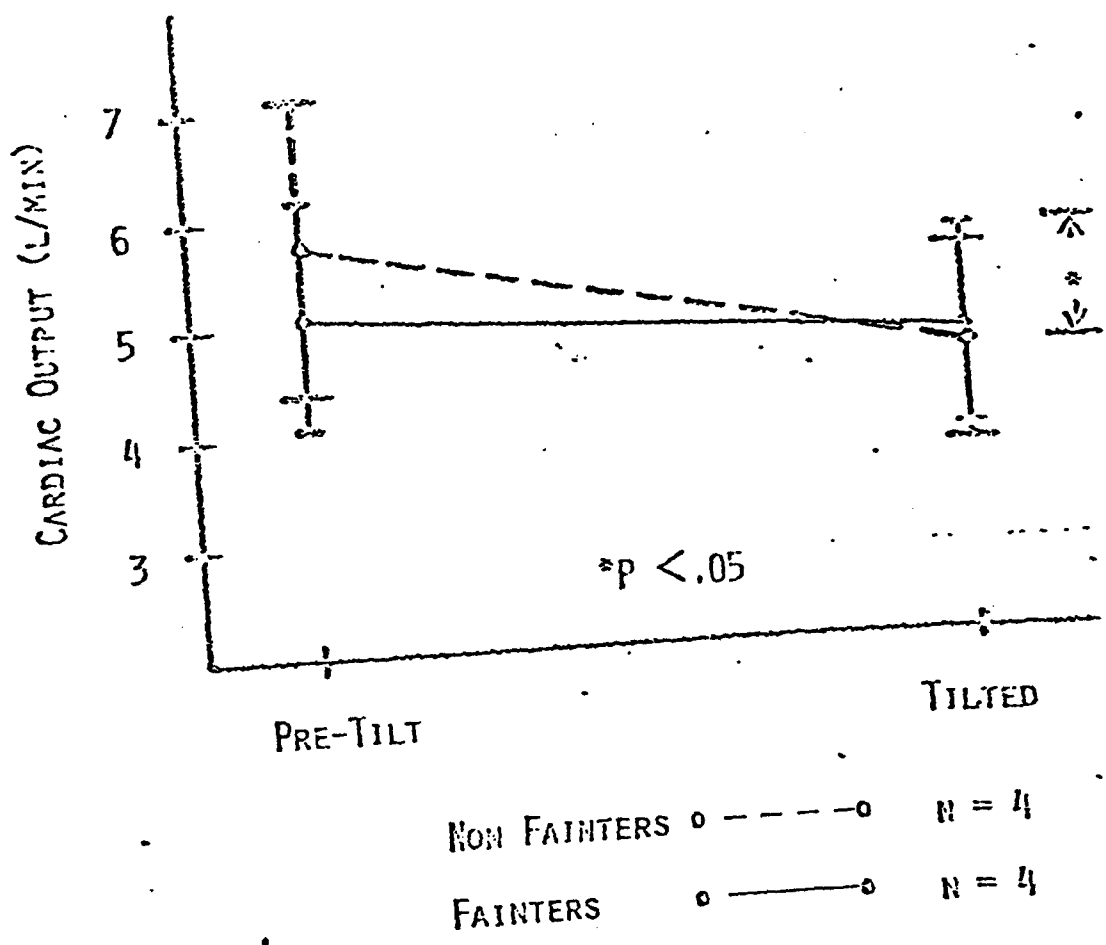

Figure 4.

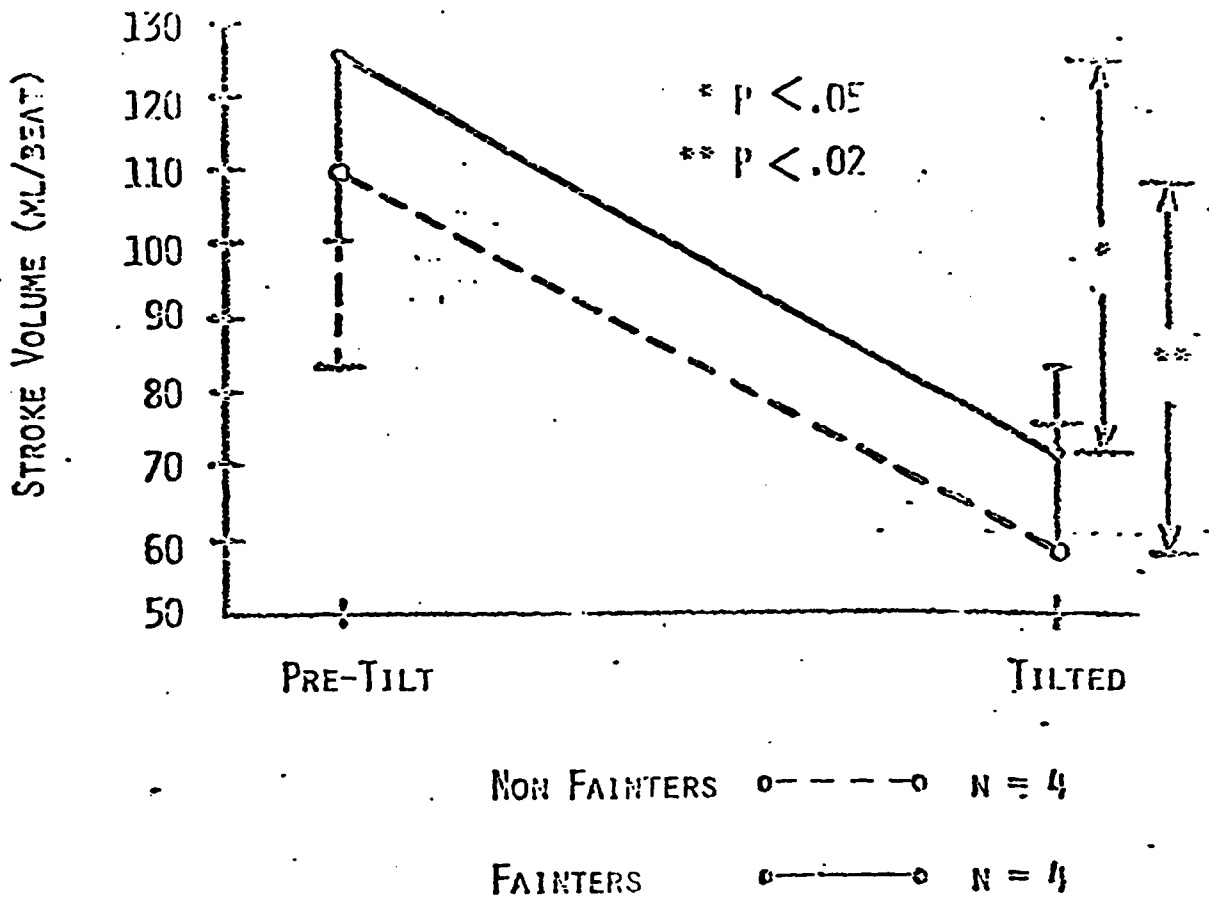

Figure 5.

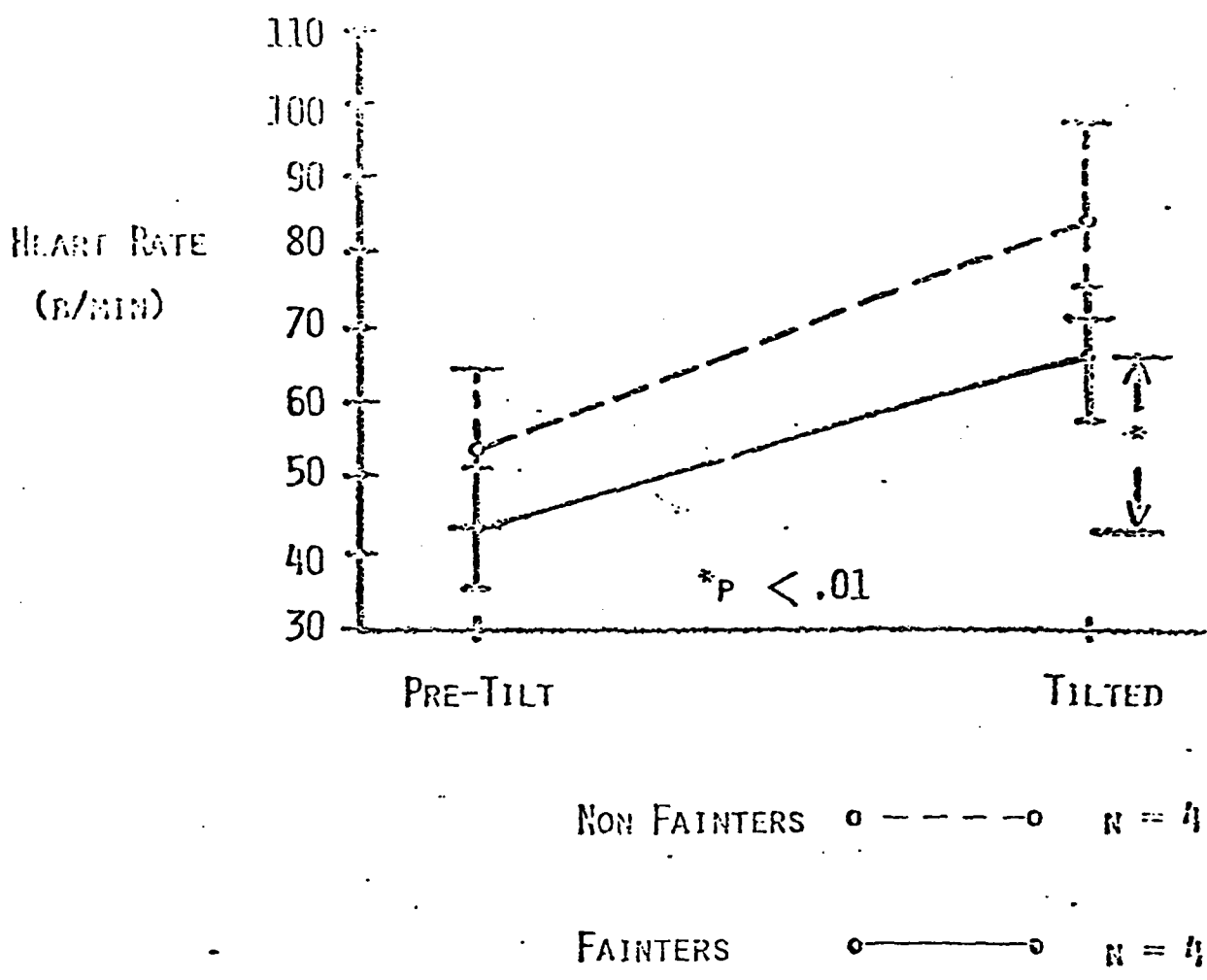

Figure 6.

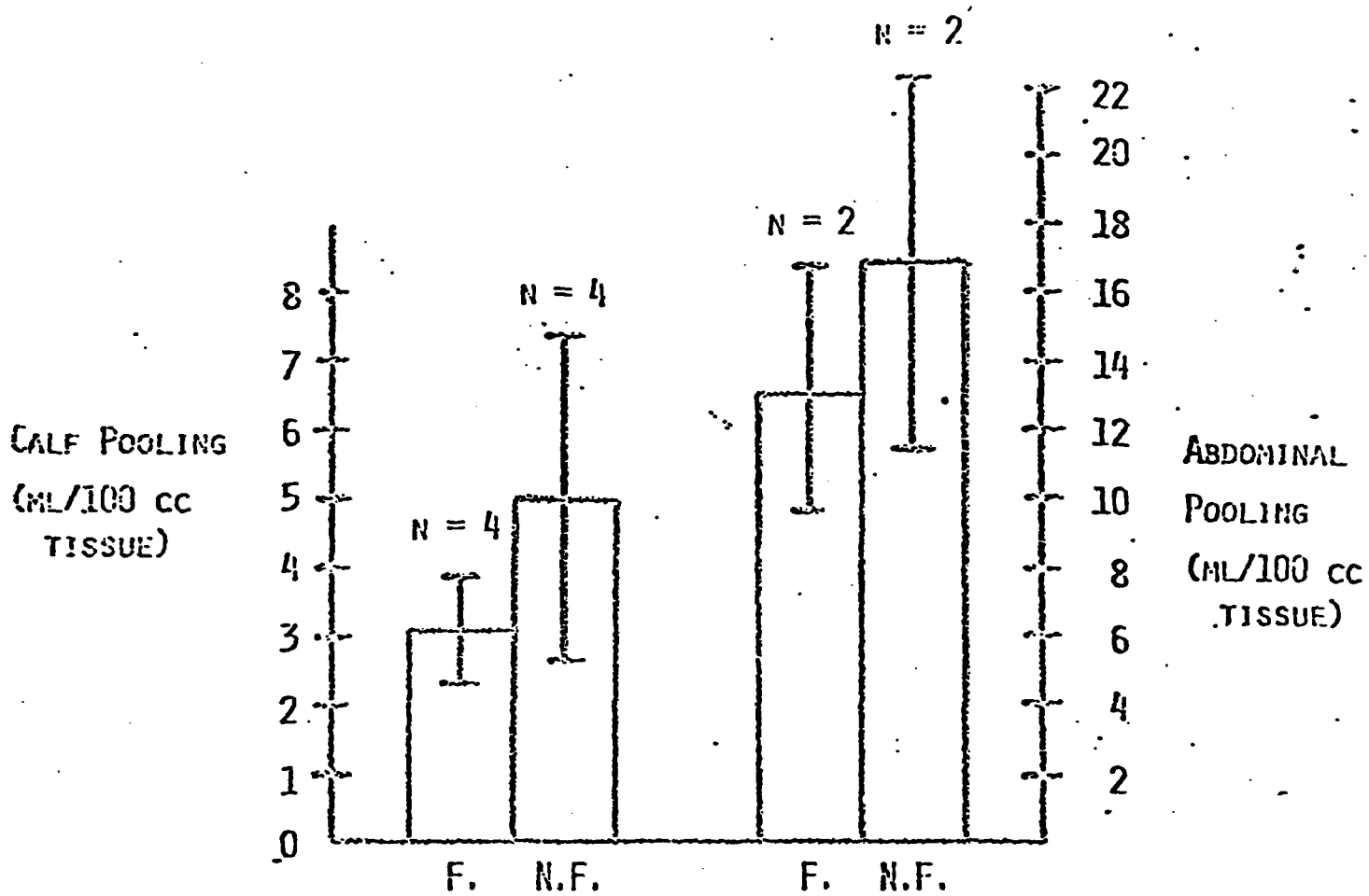

Figure 7.

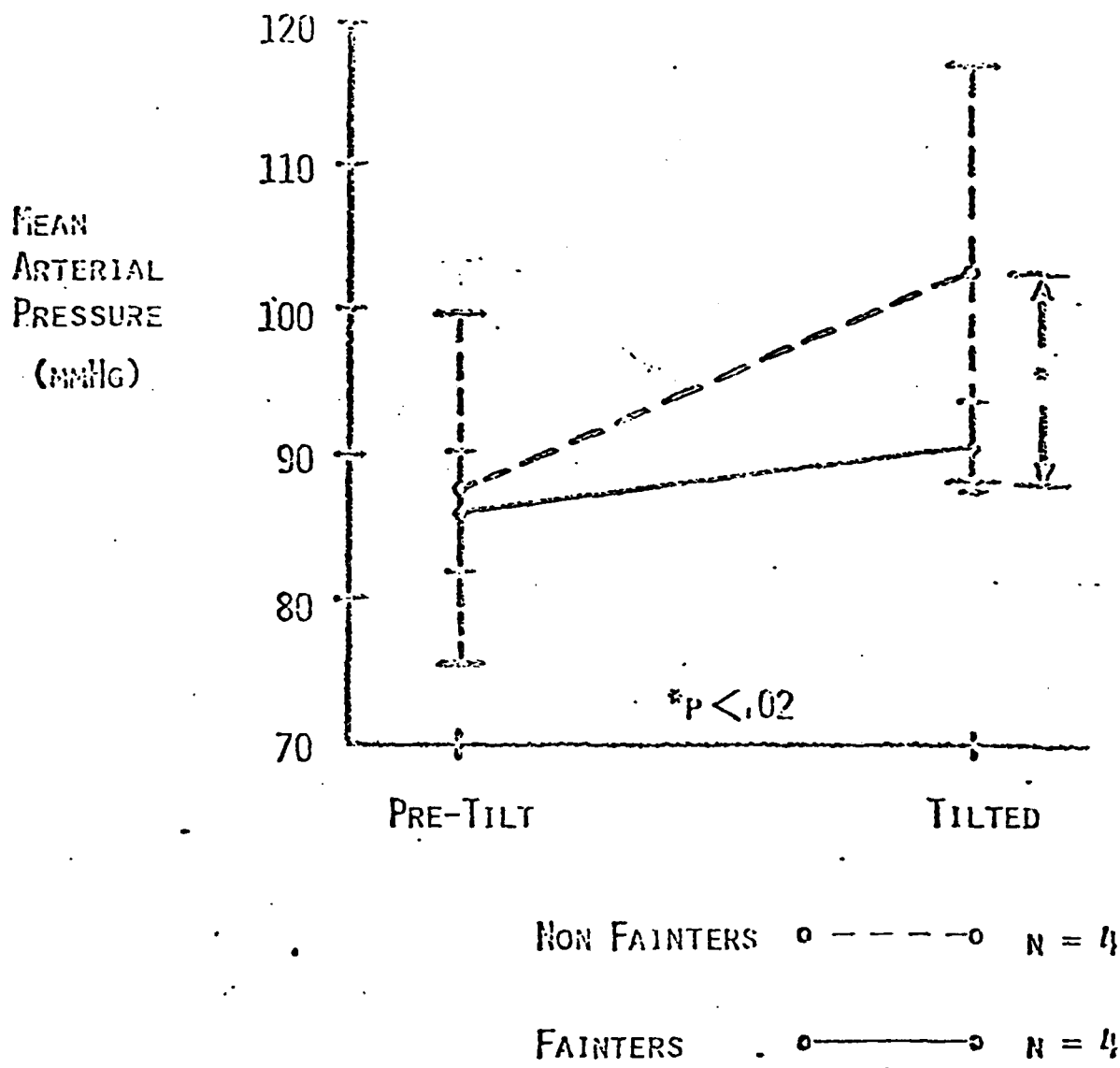

Figure 8.

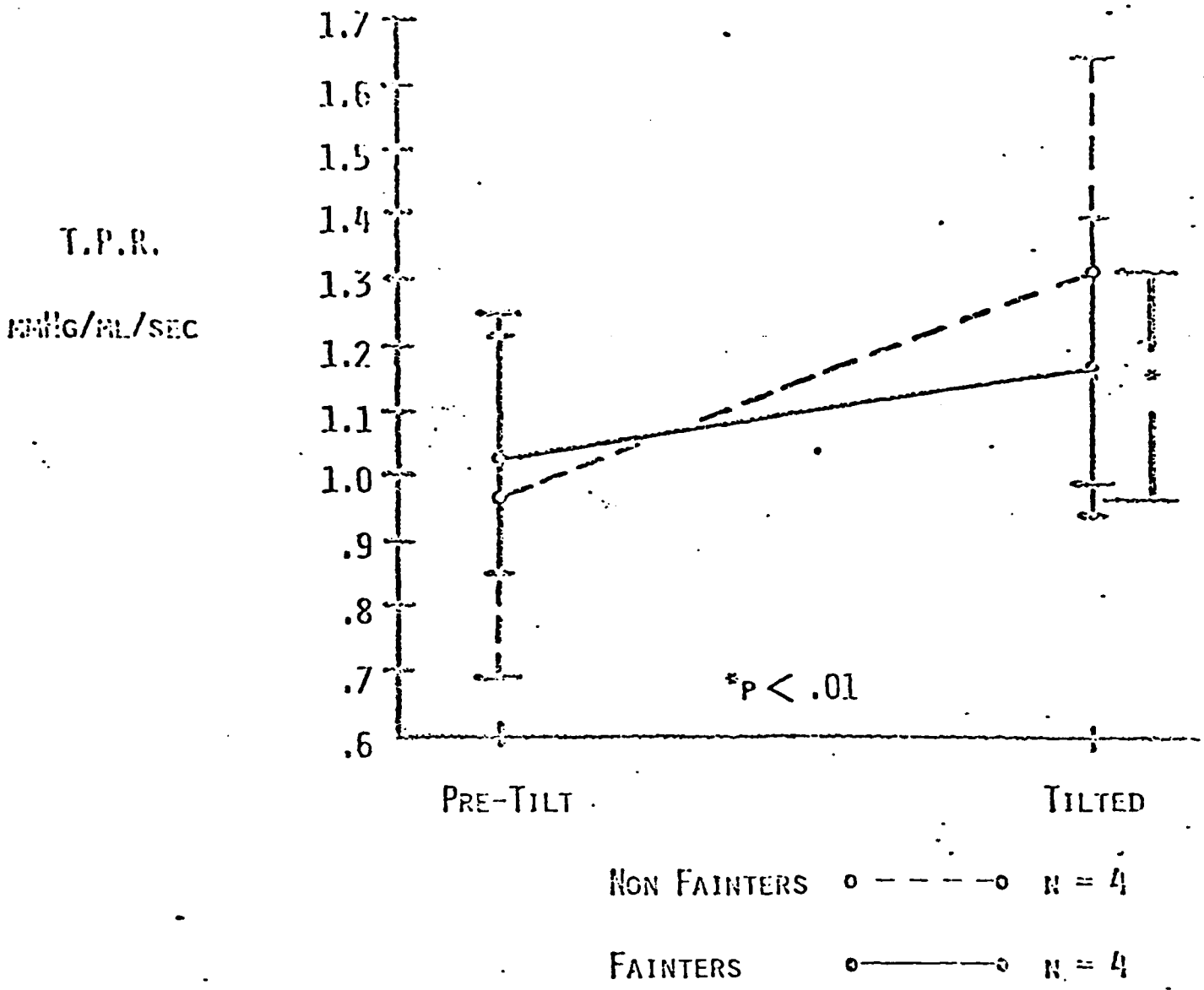

Figure 9.

Blood Resistivity Changes Associated With Orthostatic and
Exercise Stress: Impedance Cardiac Output Implications

Mangseth, G. R.

&

Bernauer, E. M.

INTRODUCTION

Electrical impedance is one of the primary non-invasive techniques used to measure cardiac output response to environmental and exercise stress. Calculation of heart stroke volume from chest impedance measurements requires a value for the specific resistance of the blood. This value is often assumed to be 150 ohm-cm. Several investigators have shown a hematocrit dependence of blood resistivity of sufficient magnitude that, if unaccounted for, could introduce significant error in stroke volume estimation. Rosenthal and Tobias measured human blood resistivity at 37°C and 1 kHz. Extremes in hematocrit were obtained from polycythemic and leucemic individuals. Geddes and Sadler measured the resistivity of outdated blood from a blood bank at 37°C and 25 kHz. A wide hematocrit range was obtained by mixing cells and plasma in varying proportions. We have undertaken to expand on these studies in three ways: 1) by examining resistivity of fresh human blood at 37°C and 100 kHz (oscillation current frequency used by IFM Minnesota Impedance Cardiograph), 2) by examining hematocrit dependence in mixed aliquots of blood, and 3) by changing blood hematocrit in healthy individuals using exercise and postural stress and measuring the corresponding change in blood resistivity.

METHODS

Figure 1 shows the schematic for a two electrode conductivity cell fashioned from a 12 cc disposable syringe after the method described by Geddes et. al. Two stainless steel electrodes of the same inside diameter as the syringe were sealed to the face of the plunger and the inside force of the plunger barrel. Twelve gauge copper wire was silver soldered to the back of each electrode. In the case of the barrel electrode, this wire exited through the needle luer-type spigot. The plunger electrode wire ran the length of, and extended beyond the plunger shaft.

A metric scale with 1 mm increments was epoxied onto the side of the syringe to allow measurement of the distance between the electrode faces. The syringe was sealed inside a plexiglass water jacket. A small tube ran from a hole drilled in the top side of the syringe to the outside of the water jacket, to allow introduction of blood into the syringe. A piece of nylon rod was inserted into this tube to seal the blood in the syringe. An additional hole was drilled in the top of the water jacket through which was inserted a thermistor for monitoring water temperature maintained at 37°C. A Minnesota impedance cardiograph model 400 was used to measure blood impedance. Leads 1 and 2 were clipped to the barrel electrode lead and leads 3 and 4 were attached to the plunger electrode lead. This is a tetrapolar arrangement with leads 1 and 4 supplying a sinusoidal, 100 kHz current across the conductivity cell while leads 2 and 3 measure the potential difference across the blood, a reflection of the impedance of the blood.

The impedance of the blood sample was measured at two different cell lengths and the resistivity was calculated from the equation given by Geddes and DaCosta. This method of resistivity measurement eliminates the impedance associated with the electrode-electrolyte interface.

Validation of the measurement capability of this apparatus was done by measuring the resistivity of six saline solutions. Measured values compared with calculated values obtained from an equation derived by J. Nyboer,

in saline solutions describing data for the concentration dependence of resistivity found in the International Critical Tables. Measurement reproducibility was determined on blood from two subjects. A 30 cc blood sample was obtained from an antecubital vein, divided into 10 aliquots and the resistivity of each aliquot was measured.

The hematocrit dependence of blood resistivity over a wide range of hematocrits was determined on blood obtained fresh from 10 subjects. A 30 cc blood sample was taken from each subject by venipuncture of an antecubital vein. The blood was spun in a refrigerated centrifuge for 1/2 hour at 2,000 g. The plasma was pipetted off and remixed with the remaining blood cells to give several aliquots of blood ranging in hematocrit from 8-60%. The relation between hematocrit and blood resistivity was described by equations fitted using a least squares method.

Blood hematocrit was changed in 9 individuals stressed by a passive, saddle supported, feet down tilt to 70° from horizontal for periods from 10-30 minutes. A 10 cc venous blood sample was obtained from each individual before and after the postural stress. These samples were divided into 4 aliquots and the resistivity of each was determined. Hematocrit was changed in 5 subjects using a run to exhaustion on a treadmill. Resistivity was determined on venous blood samples as described for postural stress.

All blood samples were obtained by venipuncture using lithium heparinized vacutainers. Hematocrits were determined in triplicate.

Blood samples were kept on ice until the resistivity measurement procedure was begun, then pipetted into the conductivity cell and the plunger adjusted so as to obtain an impedance measurement of from 80-90 ohms on the impedance cardiograph. The conductivity cell was manually shaken at approximately 1 cycle/second with full inversion every 45 seconds to keep the red blood cells in suspension.

The impedance reading stabilized after 5-7 minutes and was recorded after ten minutes. The length of the conductivity cell was noted. The shaking was stopped briefly to allow expression of blood from the syringe, moving the plunger to a second length in the process. A second impedance reading was taken after an additional ten minutes of agitation. The resistivity of the blood sample was calculated as previously noted.

RESULTS

1. VALIDATION OF SYRINGE CONDUCTIVITY CELL USING SALINE AS THE CONDUCTOR

The syringe conductivity cell was validated using saline as the conductor. Figure 2 compares the measured resistivity values of each saline concentration against the predicted value as derived by the Nyboer equation. The measured values are in close agreement with the predicted. The average variation for the series of six determinations is 0.89 percent. Given these results, it was assumed that our application of the Geddes method would provide a valid measure of blood resistivity.

Figure 3a presents the reproducibility of the syringe conductivity cell method obtained by performing 10 repeated measurements on each of two

subjects. The standard deviations in rho units are 2.55 and 4.22 equivalent to 1.51 and 2.70 percent variability, respectively. The method thus proved to be sufficiently reliable to apply to the physiological changes observed by us in preliminary pilot work.

Figure 3b presents data obtained on 14 subjects who were stressed either by a 70° head up tilt or treadmill run exceeding the anaerobic threshold. Significant differences were found between the pre-stress and post-stress hematocrit values with mean differences of 43.2 vs. 47.4 respectively. Rho values were obtained by three different means 1) by the direct measurement of the resistivity of the specific blood sample, 2) estimated from the quadratic curve fitted from 69 individual data points through a range of 8 to 60 percent hematocrit and 3) estimated from a linear regression of 28 data points through a physiological hematocrit range of 39 to 52 percent. A significant difference was found between pre- and post-stress rho values for all three methods of determination. However, figure 3b also indicates a significant difference between the measured and the predicted post-stress rho values using the quadratic curve. On the other hand there is good agreement between the measured and linear regression curve post-stress values.

3. CURVE FITTING OF HEMATOCRIT AND MEASURED RHO VALUES BY ORTHOGONAL POLYNOMIAL ANALYSIS

The quadratic best fit curve is presented in figure 4 and was calculated using 69 separate sets of four hematocrit observations through a non-physiological range. The correlation of .992 provides an extremely high level of predictability.

Figure 5 presents two curves. The linear regression is the one with the slightly steeper slope and is based on 28 observations all in the physiological range for blood hematocrit. The correlation between the measured hematocrit and the rho value is .974, also of high predictive value. The second curve, the lessor slope of the two, is also based on the 28 observations within the physiological range for hematocrit but was calculated using the quadratic equation. In general it underestimates the measured rho values through this range, thus the linear regression is the more precise through the physiological range.

Figure 6 compares the cardiac output computed from assumed, and corrected pre- and post-stress rho values. Using the assumed value of 150 ohm cm as a reference, rho values corrected for blood hematocrit concentrations measured immediately following post-stress show a 22.8 percent error which is equivalent to a cardiac output difference of 2.23 l/min. Post-stress cardiac output calculated from measured pre-stress hematocrit rho values resulted in an error of 12.9 percent equivalent to a 1.37 l/min. difference when compared to the assumed rho value.

CONCLUSIONS

The estimation of heart stroke and minute volumes using the non-invasive technique of electrical impedance across the chest requires the measurement of blood hematocrit to obtain valid rho values for specific resistance of the blood. A linear regression has been obtained between measured hematocrit levels and blood resistivity with a very high order of predictability through

the physiological range. Rho values corrected for hematocrit changes associated with experiments involving the stress of posture change or exercise are essential to avoid significant errors in estimating heart stroke and minute volumes.

FIG. 1 SYRINGE CONDUCTIVITY CELL AND CIRCUIT

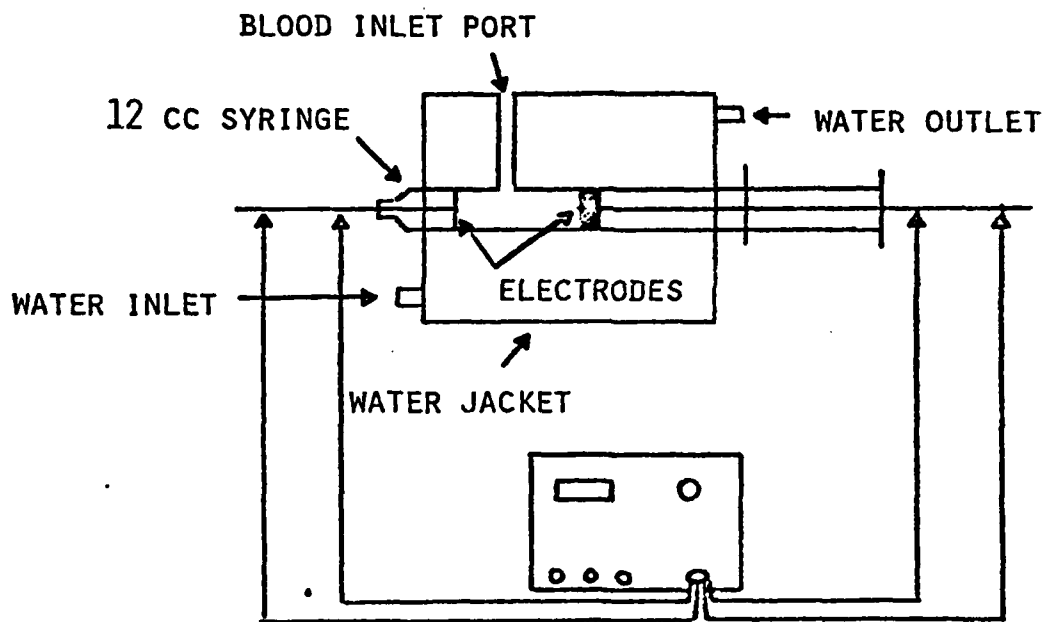

IMPEDANCE CARDIOGRAPH
IFM MODEL 400

FIG. 2 VALIDATION OF SYRINGE CONDUCTIVITY CELL USING SALINE AS
THE CONDUCTOR (N = 10 FOR EACH CONCENTRATION)

(SALINE) MILLIEQUI/LITER	P CALCULATED*	P MEASURED	% VARIABILITY
34.2	208.0	209.7	1.61
51.3	141.8	141.8	1.00
68.4	108.2	107.3	0.52
102.6	74.0	73.9	0.55
136.8	56.6	57.5	1.23
190.0	41.7	41.4	0.45

$$*P \text{ CALCULATED} = \frac{1000}{c \wedge} \quad @ \quad 37^{\circ}\text{C}$$

$$\wedge = - \frac{1}{.030285} \cdot E^{.138075} + 194.36$$

C = CONCENTRATION IN EQUIVALENTS

E = CONCENTRATION IN MILLIEQUIVALENTS

FROM: NYBOER, ELECTRICAL IMPEDANCE PLETHYSMOGRAPHY
CHARLES C. THOMAS, SPRINGFIELD, ILLINOIS, 1959

FIG. 3 MEASUREMENT REPRODUCIBILITY

SUBJECT	\bar{P}	STANDARD DEVIATION	% VARIABILITY
G.M. (N=10)	168.6	2.55	1.51
T.T. (N=10)	158.2	4.22	2.7

CHANGES IN BLOOD RESISTIVITY AND HEMATOCRIT WITH EXERCISE AND POSTURAL STRESS. COMPARISON OF MEASURED RESISTIVITY WITH PREDICTED VALUES USING LINEAR AND QUADRATIC PREDICTION EQUATIONS

	HEMATOCRIT	P MEASURED	P QUADRATIC	P LINEAR
PRE-STRESS (N=14)	43.2 + .79	163.1 + 4.8	162.5 + 3.3	164.0 + 4.8
POST-STRESS (N=14)	47.4 + .79*	184.2 + 4.9*	176.28 + 3.5†	183.6 + 4.8

* SIGNIFICANTLY DIFFERENT FROM PRE-STRESS VALUE P .001

† SIGNIFICANTLY DIFFERENT FROM MEASURED VALUE P .001

FIG. 4 BEST FIT CURVE FOR BLOOD RESISTIVITY VS
HEMATOCRIT THROUGH NON-PHYSIOLOGICAL RANGE

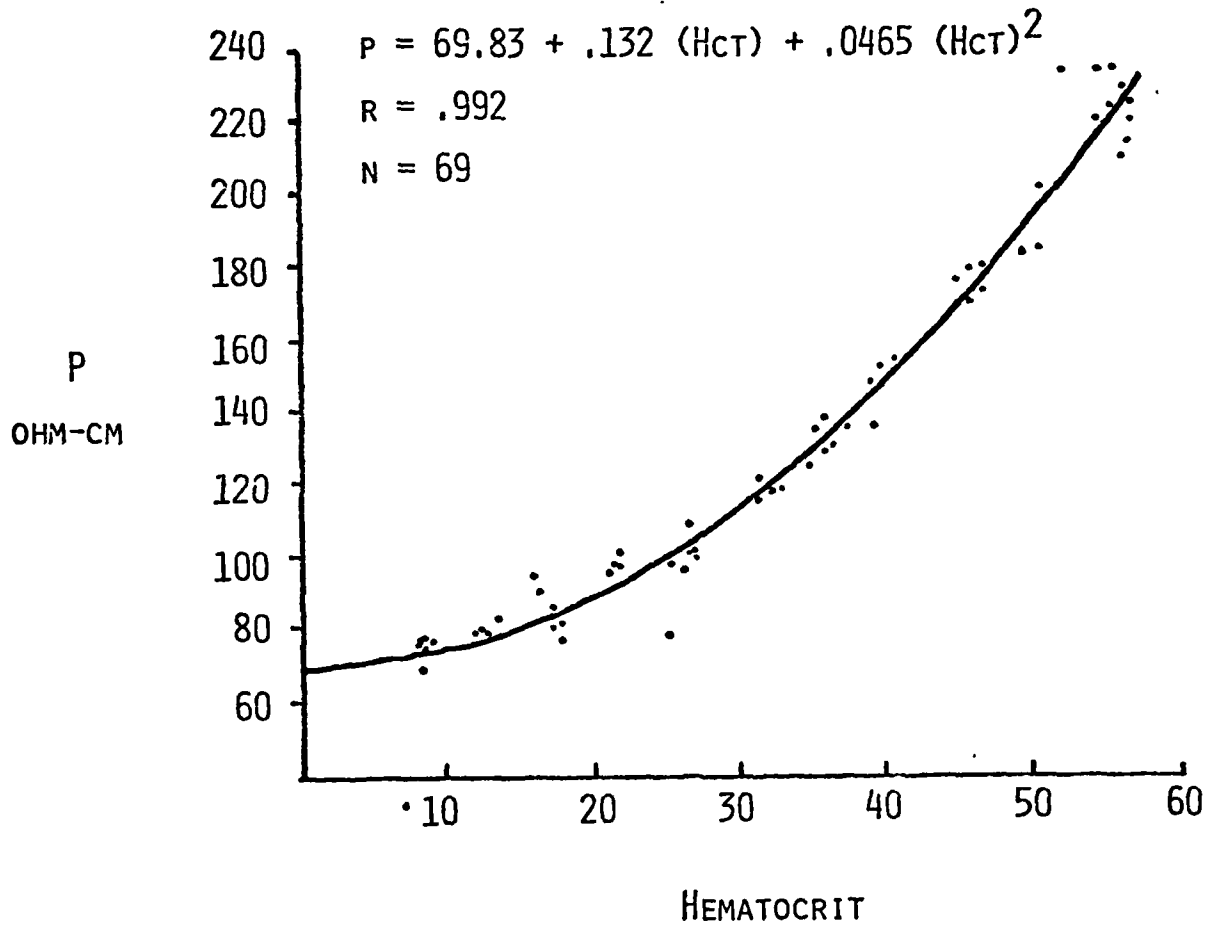

FIG. 5 LINEAR CURVE FOR BLOOD RESISTIVITY THROUGH
PHYSIOLOGICAL RANGE

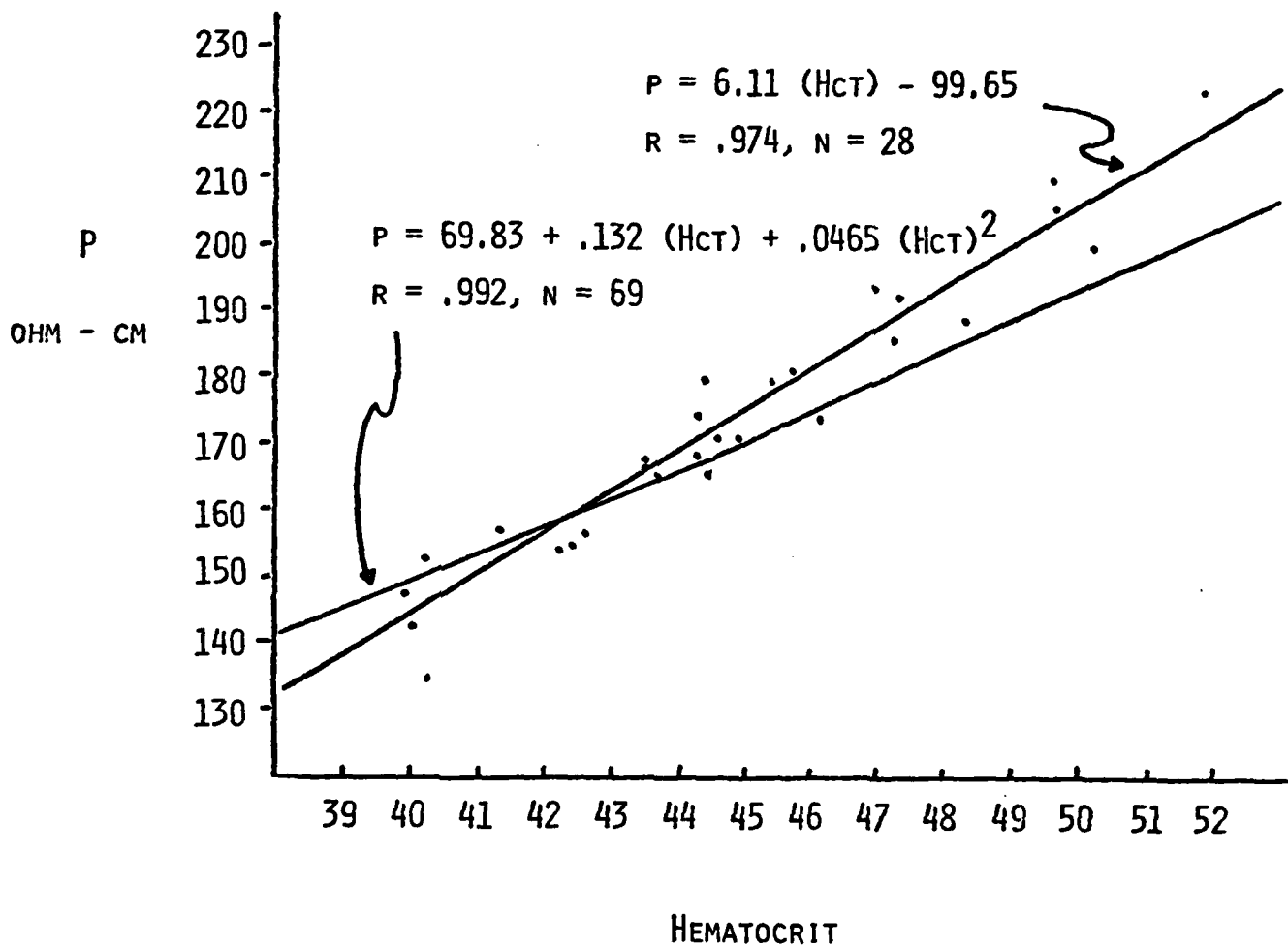

FIG. 6 ESTIMATION OF CARDIAC OUTPUT BY ELECTRICAL IMPEDANCE

$$\Delta V = P \frac{\ell^2 \frac{DZ}{DT} T}{Z_0^2}$$

P = BLOOD RESISTIVITY, OHM-CM

ℓ = DISTANCE BETWEEN INNER ELECTRODE TAPES, CHEST CM

DZ/DT = FIRST DERIVATIVE OF IMPEDANCE PULSE, OHM/SEC

T = SYSTOLIC TIME INTERVAL, SECONDS

Z_0 = MEAN CHEST IMPEDANCE, OHMS

P OHM-CM	STROKE VOLUME ML	CARDIAC OUTPUT LITERS
150	148.5	9.80
163.1	164.1	10.66
184.2	182.3	12.03

22.8% 12.9%

Comparison of Anthropometric and Functional Characteristics of
Fainters vs. Non-Fainters at 70° Head-Up Tilt
Before and After Cross Training Regimens

Mangseth, G. R.

Harrah, J. F.

Mack, G. W.

and Bernauer, E. M.

INTRODUCTION

Over the last several months our lab has been involved in studying orthostatic tolerance and its relationship to selected anthropometric and physiological characteristics as they are affected by physical condition. This is described in the first figure under phase-A. A second and related experimental program is in progress involving the cross-training of individuals high in either functional aerobic capacity or muscular strength; this is described under phase-B.

Stegemann, et. al., has presented data suggesting that blood pressure regulation in the endurance trained athlete is not as efficient as that in the average or sedentary individual. This was later corroborated by Klein, et. al., using $+G_z$ acceleration. Based on these observations, Epperson conducted a 12-week training study using Lackland AF personnel. Following significant improvements in functional aerobic capacity or strength for the running and weight groups respectively, he found a significant improvement in $+G_z$ tolerance in the strength group only. Whinnery, et. al., reported clinical findings in general support of these observations observing that the very physiological characteristics that favor $+G_z$ tolerance are related to increased risk of cardiovascular disease. Studies completed in our laboratory last year indicated that ectomorphic endurance trained individuals are more inclined to syncopal reaction during orthostatic hypotension induced by head up tilting than in the mesomorphic moderately active individual. In a series of related studies by Convertino, et. al., he found that significant modifications can be induced in blood volume and regulatory functions of the cardiovascular system by a daily 2-hour bout of exercise over a period of eight days.

The present study is an attempt to further explore the inherent and conditioning factors that effect the cardiovascular response to head up tilting in a spectrum of individuals varying from moderately active to highly trained endurance runners and to cross trained individuals who manifest high levels of functional aerobic or strength capacity.

EXPERIMENTAL PROCEDURES

A schemata of the tilting procedure is presented in Figure 2. The subject lies supine on the tilt table for a period of 90 minutes. During this period, the pre-tilt measurements are recorded including those of the central and peripheral cardiovascular functions, blood pressures, heart rate and two 10 ml blood samples are withdrawn from an indwelling catheter inserted into the subjects antecubital vein. The subject was supported by a pneumatic saddle during the tilt which was of 40 minutes duration maximum or until fainting appeared imminent judged by subject determined loss or greying of peripheral vision. during the course of the experiment cardiac output was monitored every two minutes, blood pressure every 30 seconds and heart rate and blood pooling continuously.

Stroke volume and cardiac output were estimated from chest impedance changes using an IFM Minnesota Impedance Cardiograph. A similar unit was used to monitor volume changes in the abdominal region. Calf impedance changes during tilting were monitored by a Whitney Strain Gauge which also served to validate the impedance technique.

Blood samples were aliquoted immediately following their withdrawal and prepared for analysis of hematocrit using standard clinical procedures. Sodium and potassium concentrations were measured using a IL443 model Flame photometer, osmolarity using an Adv. Instruments Freezing Point Osmometer and plasma catecholamines using a modified radioenzymatic method of Henry, et. al. (The latter determination was performed by Dr. Michael Ziegler's laboratory). The hematocrit values served also to correct the rho values used to estimate stroke and cardiac output volumes.

Anthropometric and somatotype measurements were made using the Health-Carter technique. The body composition was determined by the standard underwater immersion technique, and the $\dot{V}O_2$ max was determined on the treadmill using a modified Balke protocol with on-line respiratory gas analysis and computation employing standardized techniques used routinely in our laboratory and reported in the literature. Body volumes were determined by body immersion and the measurement of water displacement at skin temperature.

RESULTS

Table 1 presents the anthropometric characteristics of the subjects divided into two groups of eight, fainters and non-fainters. The two groups do not differ in age or height but are significantly different in body weight, LBW, percent fat and $\dot{V}O_2$ max. The common factor here is that the fainters all have high levels of functional aerobic capacity which in turn is related to lower body weight and is reflected in lower body fat and muscle mass (LBW).

Table 2 lists the mean tilt tolerance times in addition to heart to eye distances and body volumes for the two groups. Since every subject in the non-fainting group successfully managed 30 minutes of tilt, no variance was calculated. The difference between the two groups is substantial 12 minutes and 46 minutes. Although not included, most of these subjects were tilted more than once with very good reproducibility approximately ± 1.5 min. No significant differences were found between the two groups with respect to heart to eye distance or for either leg or total body volumes. The measurement for total body volume was at the level of the xyphoid process. Note that average volume for the legs is approximately equal to that of the abdominal-gluteal volume, i.e., about half of that recorded for the total body. A general observation made on several subjects was that the pooled fluid volume during the tilt extrapolated from the measurement in ml/100g tissue, \times the measured body volume was roughly equal to the individuals measured blood volume.

Table 3 presents the changes in plasma solute concentrations during the tilt. No significant difference was found between the two groups in either the hematocrit, Na^+ and K^+ concentrations or osmolarity.

Table 4 presents the same array of data as the previous Figure but expressed in terms of concentration change/minute. A significant rate change was found for hematocrit, i.e., plasma afflux but not for the electrolytes. We do not have a satisfactory explanation for the discrepancy between the hematocrit and the hemoglobin concentrations.

Table 5 presents the NEP response to tilting. The values for the pre-tilt period are not significantly different between the two groups, however, the

immediate post-tilt values show significantly greater NEP levels in the non-fainters. The absolute change is not significantly different between the two groups but appeared to be affected by a high variance in the non-fainting group. The plasma NEP concentrations agree closely with measurements made by Ziegler on supine and standing normal adult subjects.

We have dicotomized 30 subjects to date as either fainters or non-fainters. When categorized on the basis of the volume of their weekly aerobic training, we discovered the following pattern for the runners:

- a) Of those who run > 60 miles/week 9/9 are fainters.
- b) Of those who run > 45 but < 60, 3/4 are fainters.
- c) Of those who run > 20 but < 45, 3/5 are fainters.
- d) Of those who run > 20, only 1/2 are fainters.

We are currently engaged in a cross-training study of subjects with high levels of either functional aerobic or strength capacity. Subjects are given specific training regimens emphasizing the physical capacity which is less developed while modifying but not eliminating their normal training routine.

The very preliminary results of our cross-training study is presented in Table 6. Again note that the runner-fainter is lighter, has less muscle mass and has a higher $\dot{V}O_2$ max. Following a 12-week training program of weight training the runner increased his tilt-tolerance and the weight conditioned-endurance training subject did not change. A second highly trained endurance runner has recently completed his weight training and also increased his tilt tolerance 4-fold, but we do not have his data analyzed. Six additional subjects are currently in different phasis of their specific training programs.

CONCLUSIONS

In conclusion, it appears that the ectomorphic, endurance trained individual is more inclined to syncopal response during head up tilting than is the mesomorphic, moderately trained individual. The significantly different anthropometric characteristics between the two groups are those associated with greater body weight and body density in the non-fainters which is reflected in greater muscle mass. Linear dimensions and body volumes were similar for the two groups. This is in agreement with Klein et. al. who reported equivocal results to orthostatic tolerance with respect to static anthropometric heart to eye dimensions.

Earlier studies in our laboratory demonstrated that the syncopal response was not related to inordinate blood pooling in dependent body regions nor to a greater reduction in cardiac output. The present investigation corroborated these findings revealing a similar pattern and magnitude of the hematocrit electrolyte and osmolality response to tilting in the two groups. The plasma efflux is essentially isotonic which agrees with earlier investigations related to various modes of environmental stress. However, the hematocrit change/unit time does suggest a greater rate of plasma loss in the fainters.

A major difference in the two groups studied appears to involve the regulation of the TPR. Last year we reported that the non-fainters were able

to increase their MAP in the face of a falling cardiac output and to increase their TPR. The present study shows that the non-fainters also have a significantly higher NEP levels following tilting. Barcroft and Edholm believe syncope is related to a precipitous drop in TPR and feel such a drop to be related to the activity of the vasomotor nerves. If that is the case, we could postulate a major difference in neural control of the peripheral vasculature in the endurance trained individual. Our very preliminary work in cross-training suggest that orthostatic tolerance can be modified in a relatively short time frame. The recent review by Reid, Morris and Ganong present sufficient evidence for a neural humoral mechanism in support of empirical observations by Kala, Devies, Matalon and Farhi, Kotchen, et. al., and Hartly, et. al., and Ragge, related to the direct effect of NE on peripheral resistance or through the renin-angiotensin mechanism, see Figure 3.

FIGURE 1. ROLE OF PHYSICAL STATUS AND TRAINING ON HSG TOLERANCE

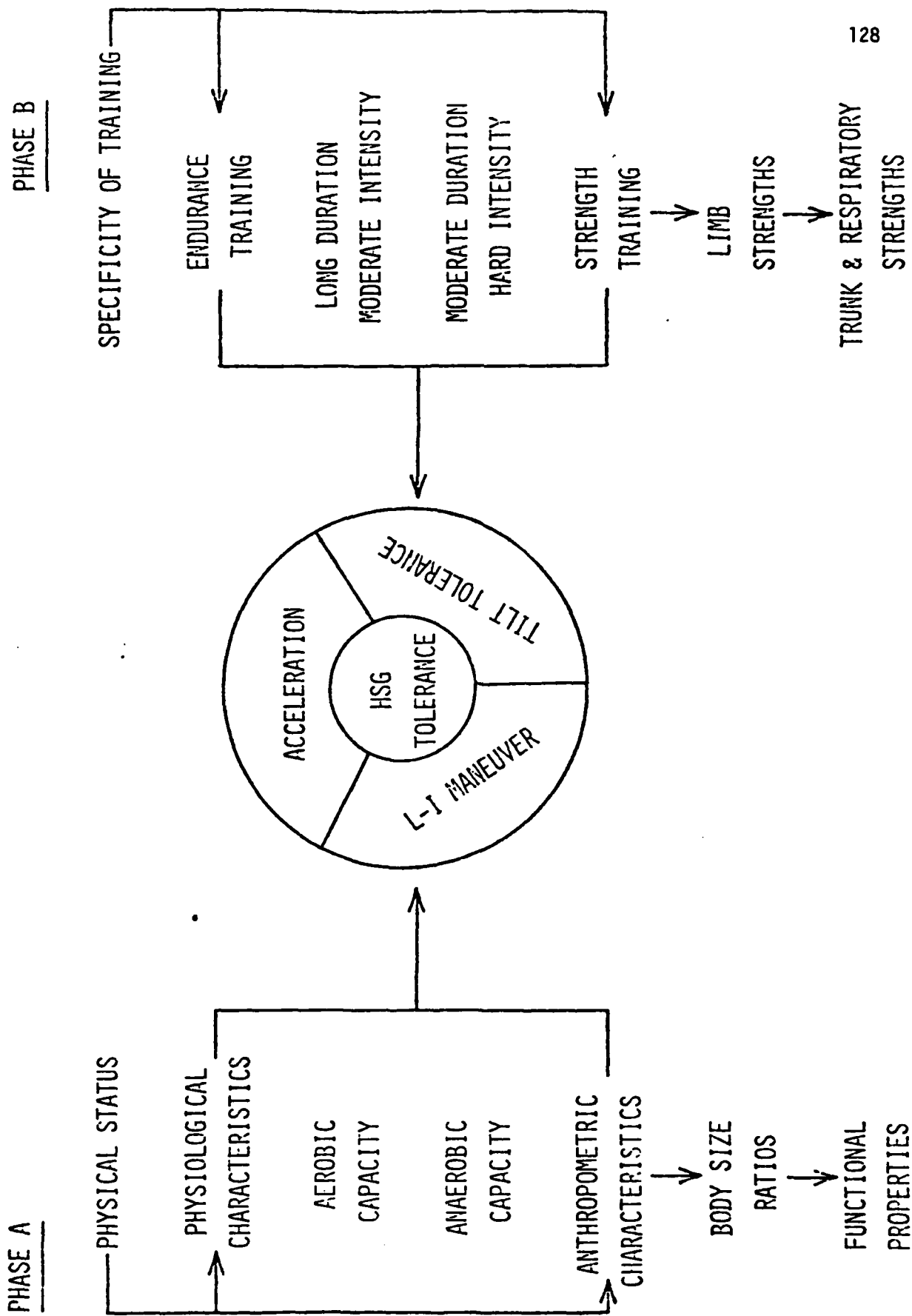

TABLE 1. ANTHROPOMETRIC CHARACTERISTICS OF SUBJECTS

VARIABLE	N	AGE (YRS)	HEIGHT (CM)	WEIGHT (KG)	LBW (KG)	% FAT (%)	$\dot{V}O_2$ MAX (ML KG ⁻¹ MIN ⁻¹)
FAINTERS							
\bar{X}	8	25.4	182.7	71.6	63.8	11.0	57.1
S		7.1	6.97	9.34	8.07	3.2	9.12
NON-FAINTERS							
\bar{X}	8	22.5	184.6	91.8	75.6	17.2	46.9
S		5.9	7.85	14.95	11.72	7.8	5.54
		N.S.	N.S.	<.05	<.05	<.05	<.05

TABLE 2. Tolerance Times, Heart-Eye Distance
& Body Volumes in Fainters & Non-Fainters.

VARIABLE	N	MEAN TILT TIME (MIN)	HEART-EYE DISTANCE (CM)	HEART-EYE (% OF BODY HEIGHT)	LEG VOL (ML)	TOTAL TRUNK BODY VOL (ML)
FAINTERS						
\bar{X}	8	17:46	31.227	17.1	23711.12	42861.2
S			3.343	1.4	7063.7	3886.2
NON-FAINTERS						
\bar{X}	8	30:00	31.292	17.2	25924.8	51991.8
S			1.484	0.7	6608.0	12549.0
			N.S.	N.S.	N.S.	N.S.

TABLE 3. CHANGES IN PLASMA SOLUTE CONCENTRATIONS DURING TILT

VARIABLE	N	Δ HCT (%)	Δ [HB] (G DL ⁻¹)	Δ [Na ⁺] (MEQ L ⁻¹)	Δ [K ⁺] (MEQ L ⁻¹)	Δ OSMOLARITY (MOSM L ⁻¹)
FAINTERS						
\bar{X}	10	3.31	1.04	- 1.24	0.06	- 4.90
S		1.28	0.92	1.58	0.10	16.91
NON-FAINTERS						
\bar{X}	14	3.89	1.43	- 0.86	0.15	- 2.68
S		1.21	0.40	1.30	0.22	7.65
		N.S.	N.S.	N.S.	N.S.	N.S.

TABLE 4. CHANGES IN PLASMA SOLUTE CONCENTRATION PER MINUTE

VARIABLE	Δ HCT (%)	Δ HB (G DL ⁻¹)	Δ [Na ⁺] (MEq l ⁻¹)	Δ [K ⁺] (MEq l ⁻¹)	Δ Osm (MOSM l ⁻¹)
FAINTERS					
\bar{X}	0.2470	0.0604	-0.0854	0.0094	-0.1285
S	0.1410	0.0417	0.1155	0.0253	0.8857
NON-FAINTERS					
\bar{X}	0.1263	0.0485	-0.0327	0.0057	-0.0893
S	0.0427	0.0144	0.0343	0.0074	0.2551
	.05	N.S.	N.S.	N.S.	N.S.

TABLE 5. NOREPINEPHRINE RESPONSE TO TILT

		PLASMA NOREPINEPHRINE (PG M λ ⁻¹)			Δ NEP
		N	PRE	POST	
FAINTERS					
\bar{x}	13	189.77	382.33	213.00	
S		96.80	146.62	137.04	
NONFAINTERS					
\bar{x}	9	224.33	579.78	355.44	
S		82.83	162.96	186.69	
		N.S.	<.05	N.S.	

TABLE 6. CHANGES IN ORTHOSTATIC TOLERANCE FOLLOWING CROSS-TRAINING PROGRAM

SUBJECT	AGE (YRS)	HT (CM)	WT (KG)	LBW (KG)	% FAT (%)	$\dot{V}O_2$ MAX (ML KG ⁻¹ MIN ⁻¹)	TILT TOLERANCE (MIN AT 70°)	TRAINING
(A)								
PRE	22	173.7	64.2	56.9	11.5	62.4	21.3	RUNNING > 60 MI/WK
POST			64.1	57.3	10.6	63.6	30.0	WEIGHT LIFTING
(B)								
PRE	20	177.2	81.5	71.9	11.9	51.0	30.0	WEIGHT LIFTING 3/WK
POST			83.7	72.3	13.6	55.3	30.0	BICYCLE ERGOMETER 3 HR/WK

FIGURE 3. Neural Humoral Mechanism Hypothesized Having A Direct Effect On Peripheral Resistance

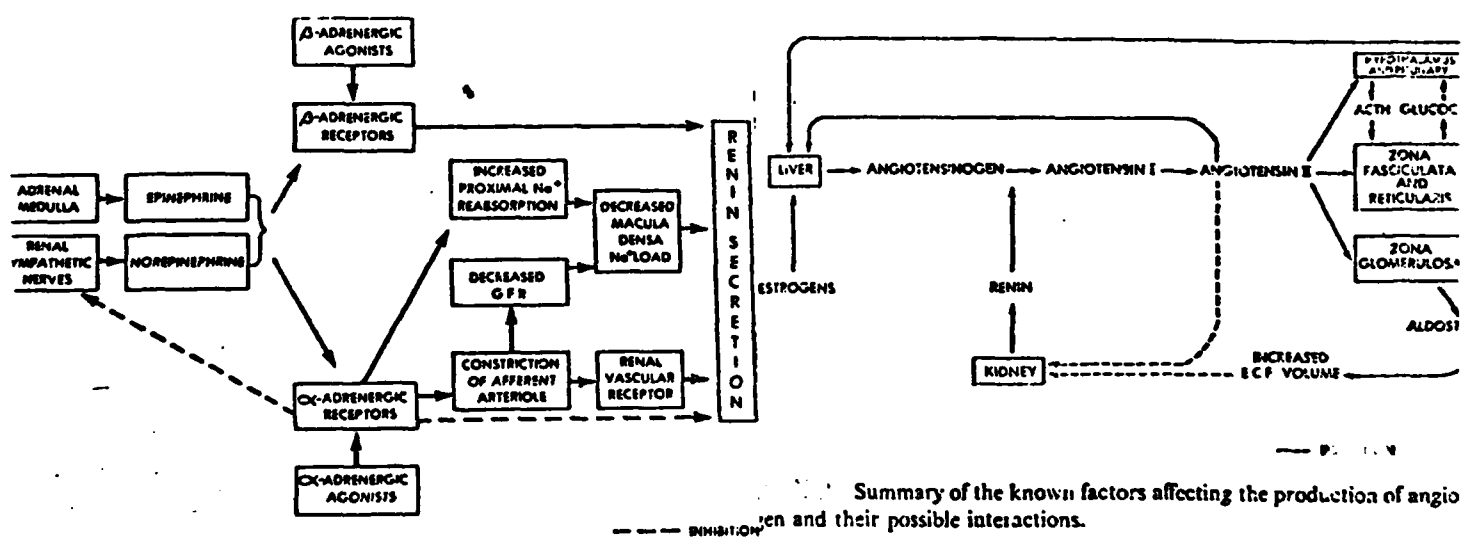
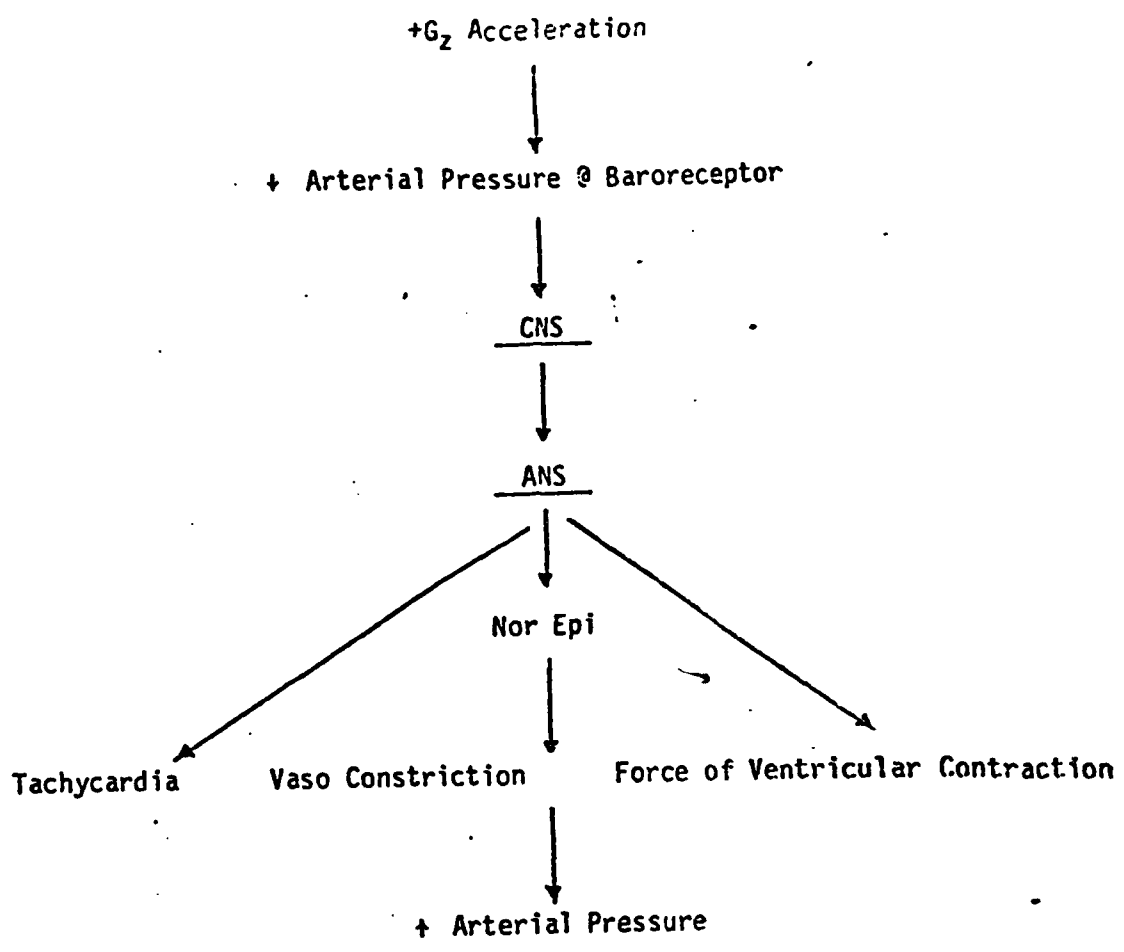

Summary of known and postulated effects of α - and β -adrenergic stimulation on the secretion of renin.

Summary of the known factors affecting the production of angiotensin and their possible interactions.

Distinguishing Anthropometric and Physiological
Characteristics of Fainters and Non-Fainters:
Application of Two Differing Tilt Formats
and Determination of Optimal Time Dichotomies

by

Ed Bernauer, John Graham, and Jack Harrah

Annual Review of Air force Sponsored Basic Research
in Environmental Physiology and Biomechanics, March 15 - 17, 1982

INTRODUCTION

A pilot's tolerance capability in a high +G_z environment is a function of the inherent G-tolerance or relaxed G-tolerance, anti-G suit function, and an active straining maneuver, either M-1/L-1. Our lab has focused on the first and the third of these three contributing functions to orthostatic tolerance. Relaxed G-tolerance was first thought to be fairly well fixed for any given individual but Whinnery, et. al., 1978, reported an increase with age and in persons of below average physical fitness. Wishing to explore these observations further, we have attempted to identify those anthropometric and physiological characteristics, i.e., structure-functional factors that would contribute to a predictive profile of relaxed G-tolerance; particularly those characteristics influenced by physical training. Secondly, we have pursued a series of experimental physical training studies to determine the specific nature of physical training regimens on the underlying physiological adaptations and the associated changes in orthostatic tolerance. Stegemann, et. al., 1974, reported that endurance reduced the effectiveness of the blood pressure control system; this is advantageous for the integrative control of the circulatory system during exercise but disadvantageous during orthostatic tolerance especially stress. This was later corroborated by Klein, et. al., 1977 whose studies included relaxed G-tolerance; They found a significant positive correlation with prestress Pa and a negative correlation between the heart-eye volume. Based on these observations, Epperson, et. al., 1978, conducted a physical training study which compared strength vs. endurance and found significantly in favor of strength-weight training. Studies conducted in our lab over the last three years have found a negative relationship between mileage run/week and incident of fainting and a tendency to increase orthostatic tolerance measured by tilt following weight training of high mileage endurance athletes. At present, we are engaged in a series of experiments which involve very specific training regimens designed to identify an optimal training program for orthostatic tolerance and its impact on the underlying physiological mechanisms. Two general loci of control are being tested: 1) A neural-endocrine control of the peripheral vasculature affecting TPR in muscle, skin, and splanchnic area as first postulated by Brigden, Howarth, and Sharpey-Schafer and more recently updated in a review by Morres and Ganong with respect to blood volume and pressure. The second locus of control being tested is a central mechanism described by the Bazold-Jarisch reflex mediated by mechanoreceptors in the LV responding to a distortion of the ventricle wall.

The present report addresses our recent effort to discriminate between fainters and non-fainters based on anthropometric and physiological characteristics and an optimal tilt time procedure used for screening.

EXPERIMENTAL PROCEDURES

A total of 23 young males were selected representing athletes from the varsity cross-country, basketball, baseball, and wrestling teams: included also were a few non athletes to round out a range of anthropometric and physiological characteristics typical of air force pilots. The array of athletes represent various somatotypes and degrees of endurance/strength capacities. Two tilt protocols were applied to each subject; A continuous 70° tilt at 26°C ambient temperature to establish their relaxed orthostatic tolerance and to categorize fainters vs. non-fainters. The physical

characteristics are summarized in Table 1. The second tilt procedure employed a graded protocol for 2-min. each at 10°, 30°, 50°, and 70° tilt angles designed to determine onset and magnitude of selected physiological responses, see Table 2. The cutaneous circulation was studied under conditions of active vasodilation and reduced orthostatic intensity. Reduced vasocinstructor response to a rate which permitted individual IR-thermographic measurements of skin temperature to illustrate time course of the baroreflex response. Measurements of skin temperature were made with an AGA thermovision system 680/102B and documented with a thermograph taken by a polaroid land camera back (see Figure 1). A water bath adjusted to 30°C was used as the temperature reference to convert the thermographs to absolute temperature. The statistical comparison between fainters and non-fainters was analyzed using multiple comparative T-tests and a composite analysis using Hotelling's T^2 statistic, which tests homogeneity of covariances in two populations. An analysis of variance for repeated measurements was used to analyze the dose-response test.

RESULTS

Figure 2 shows time distribution of subject tilt tolerance to 40 minutes, 70° head-up tilt. Six subjects tolerated 40 minutes and were non syncopal while 17 subjects were syncopal ranging in onset from 3 to 38.5 minutes with some congregation at 20 minutes.

Physical Characteristics: Figure 3; When the group is dichotomized at 20 minutes, a multi-variate composite analysis of the physical characteristics indicates a significant difference exists between fainters and non-fainters at $p < 0.05$ level. However, a discrete analysis failed to reveal a significant difference for any single characteristic. No differences were found amongst subjects dichotomized at 30 minutes. Most subjects were meso-ectomorphic in body build (see Figure 4) and ranged between 110 to 200 lbs. and 5' to 6'2".

Physiological Characteristics: Eight physiological variables presented in Figure 5 again shows a significant difference between subjects at 20-minutes, but not at 30 minutes. Unlike the physical characteristics four of the eight physiological variables were found significant by discrete analysis vis., HRmax, DBPmax, DBPmean and SBPmean.

Comparison of vasomotor response between fainters and non-fainters for the dose-response tilt reveal calf skin temperature decreased significantly from 35.35 to 34.79°C during dose-response tilt, Figures 6 and 7. Discrete analysis were significant only between 50-70 degrees of tilt and mean CV-variables are presented in Figure 7 for the entire group and the arrows indicate where the significant differences lie with respect to the incremental step tilt angles. No one variable provides a single dimensional criteria of orthostatic tolerance through the entire range of the step tilt. However HR provides the single best measure and the combination of HR and DBP appear optimal criteria.

Comparison of skin temperature and CV-variables for fainters vs. non-fainters dichotomized at 20 and 30 minutes from dose response tilt showed no significant differences are found for calf skin temperatures between the 20 or 30 minute dichotomy or between fainters [0] and non-fainters [] although there is an acute measureable drop between 50° and 70° for the step tilt protocols dichotomies. Heart rates presented in Figure 9 increased from 62 to 87 (b/m) during the dose-response protocol. Significant changes first occurred at 30 degrees; was lower but not significantly so in the fainters and similar in response for both 20 and 30 minute dichotomy.

Systolic blood pressure (SBP) decreased significantly for the subject sample, with the first angle of significance occurring at 50 degrees as illustrated in Figure 10. Non-fainters have higher SBP than fainters but not significant: the SBP at 20 minute dichotomy is significantly higher for non-fainters when compared to fainters.

Diastolic blood pressure (DBP) for the entire sample increased from 64 to 78 torr. The significant changes occurred at 10 and 30 degrees. No significant differences were found between fainters vs. non-fainters at either the 20 or 30 minute dichotomy. However, fainters regulate up to 50 degrees while non-fainters continued to regulate through 70 degrees as illustrated in Figure 11.

Pulse pressure (PP) decreased significantly for the total subject sample 50 - 28 torr with the greatest and only significant discrete change occurring at 30 degrees. The non-fainters differ significantly from the fainters at the 20 minute dichotomy and are consistently higher (see Figure 12).

SUMMARY AND CONCLUSIONS

Young, adult men respond to 70° head-up tilt by exhibiting signs of orthostatic distress, vasovagal symptoms and syncope. Orthostatic tolerance is a time intensity and symptom limited feature of the upright posture. The classic cardiovascular response to orthostasis is an increase in heart rate, blood pressure, and peripheral vascular resistance, and a decrease in cardiac output.

The subjects response to incremental tilt is characterized by an increase in peripheral vascular resistance at low angles, while cardiac effector mechanisms take precedence at higher angles of tilt. It is apparent that both time and degree of exposure to orthostatic stress are fundamental to the characterization of orthostatic tolerance.

For the present, no method for adequately predicting orthostatic tolerance is apparent. Analysis of physical anthropometry, and cardiovascular response to head-up tilt yielded essentially no consistent explanation for the difference between fainters and non-fainters. Until a more standardized format, sensitive measurements, and a clearer understanding of the underlying mechanisms evolves, a definitive difference between those who respond by fainting and those who do not remains tentative.

CONCLUSIONS

1. A 20-minute dichotomy of tolerance times proved superior to 30/40 min. in discriminating fainters from non-fainters.
2. Although a significant difference was found for physical characteristics generally, no single characteristic proved to be significant.
 - a) This indicates a substantial interaction of the various physical characteristics.
 - b) It also indicates a need to identify the basic properties, both structural and functional which affect orthostatic tolerance.
3. Four physiological variables HRmax, DBPmax, $DBP\bar{x}$, and $PP\bar{x}$, significantly distinguish fainters from non-fainters.
4. Dose (step) response tilt can further distinguish fainters from non-fainters by:
 - a) Differentiation of on-set time for cardiac vs. vasomotor response.
 - b) Differential maintenance of control.
5. Step protocol would appear to provide a more sensitive test to assess the effects of specific training.

Table 1: Physical characteristics of the experimental subjects

Subject	Tilt Time (min)	Age (yrs)	Ht (cm)	Wt (kg)	$\dot{V}O_2$ (L/m ² n)	BF (%)	HC1 *	HC2 *	HC3 *	HR (b/m)	SBP (mmHg)	DBP (mmHg)	PP (mmHg)
1	3.0	43	186	76.7	3.74	8.11	2.5	6.0	3.5	63.2	120.1	88.1	31.7
2	3.5	19	168	58.3	3.36	6.69	2.0	5.5	3.5	56.4	112.3	66.4	45.9
3	4.0	26	181	70.0	4.50	12.67	3.0	4.5	3.5	49.2	107.9	70.1	37.8
4	10.5	19	165	53.4	3.39	9.35	2.5	5.5	3.5	54.4	108.2	52.2	56.0
5	12.0	28	176	64.7	3.74	11.56	2.5	3.5	3.0	72.2	96.3	63.8	32.5
6	13.5	19	189	89.1	5.70	10.29	2.5	5.0	4.0	52.7	130.8	64.1	66.7
7	17.0	27	182	63.8	3.68	4.40	1.5	2.5	5.0	42.4	122.1	59.3	63.0
8	19.0	22	170	50.0	2.84	14.10	1.5	2.5	5.5	100.4	98.2	65.2	33.0
9	21.5	19	195	84.4	5.38	11.51	2.0	5.0	4.0	71.8	118.2	67.3	50.9
10	21.5	24	186	64.2	4.28	9.14	2.0	2.5	5.5	60.0	122.5	69.7	52.8
11	22.0	19	195	94.2	4.40	18.74	6.0	5.0	3.0	63.7	126.8	55.5	71.3
12	29.5	19	154	77.2	3.70	11.49	2.5	4.5	3.0	73.8	125.1	72.4	53.2
13	30.5	19	154	49.5	3.63	5.87	2.0	5.0	2.5	49.6	122.4	61.9	60.5
14	31.0	21	181	72.8	4.38	8.48	2.5	4.0	3.0	63.3	126.4	74.5	51.9
15	34.5	23	186	77.9	4.08	19.95	4.5	4.5	3.5	70.8	115.1	58.6	56.5
16	36.0	23	177	67.8	3.33	14.04	4.5	3.5	3.5	76.4	114.7	62.6	52.1
17	38.5	22	171	58.1	3.10	10.39	1.5	3.5	4.0	67.0	116.6	69.2	47.4
18	>40.0	28	182	60.8	3.03	9.00	2.0	2.0	5.5	92.4	115.3	71.1	44.2
19	>40.0	23	180	72.9	4.95	7.86	1.5	4.5	3.0	62.0	118.8	69.0	49.8
20	>40.0	20	170	59.1	3.96	10.11	3.0	4.0	3.5	50.8	130.3	68.6	61.7
21	>40.0	19	170	57.6	3.50	6.23	3.0	4.0	3.5	62.6	123.3	74.1	49.2
22	>40.0	19	170	62.8	3.91	12.50	2.5	5.0	2.5	58.9	107.3	60.0	47.3
23	>40.0	19	168	65.9	4.50	12.35	3.5	4.5	2.0	63.4	109.6	57.6	52.0
Mean		22.6	178.1	67.4	3.96	10.64	2.65	4.2	3.63	64.2	116.9	66.1	50.7
S.D.		5.42	10.04	11.85	0.726	3.76	1.10	1.07	0.95	13.41	9.25	7.67	10.42

* Components 1, 2, & 3 of the Heath-Carter Somatotype

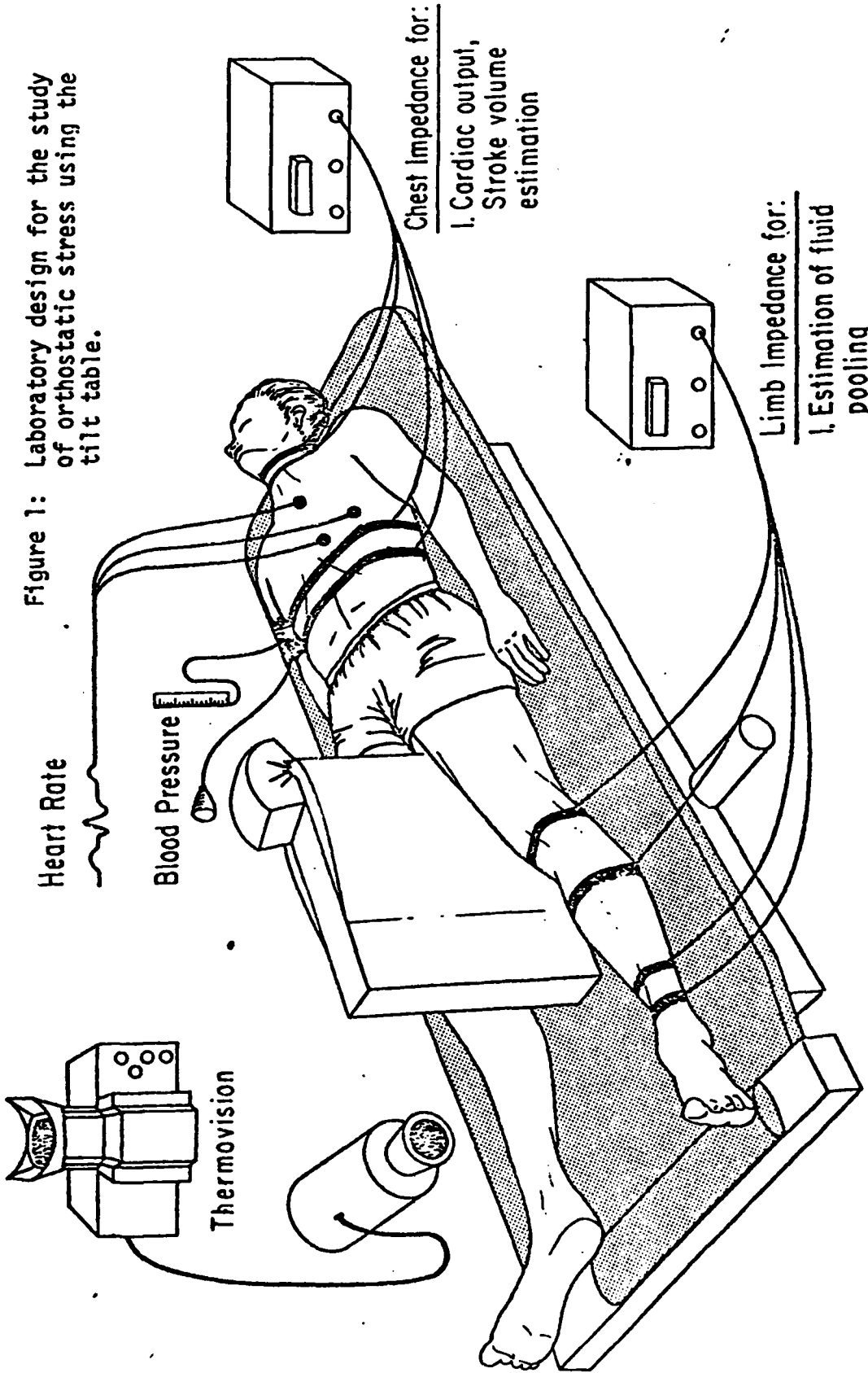

Figure 1: Laboratory design for the study of orthostatic stress using the tilt table.

TABLE 1. Protocol for 70° head-up tilt at 26° C

	Pre-tilt Supine	70° head-up tilt					Post-tilt Supine
Time (min.)	1 2 3 4 5	1	10	20	30	40	1 2 3 4 5
Heart Rate		←	←	←	←	←	
Systolic Pressure		←	←	←	←	←	
Diastolic Pressure		←	←	←	←	←	
Subjective Reaction		←	←	←	←	←	

TABLE 2. Protocol for dose-response tilt at 30° C

	Pre-tilt Supine	Period of Vasodilation	Pre-tilt Supine	10°	Dose-response tilt 30° 50°	70°	Post-tilt Supine
Time (min.)	1 2 3 4 5	1 2 3 4 5 6	1 2 3 4 5	1 2	3 4 5 6	7 8	1 2 3 4 5
Ambient Temperature	26° C	26° → 30° C	30° C	→			
Heart Rate		←	←	Continuous recording →			
Systolic Pressure		←	←	Recorded at 30 Sec. intervals →			
Diastolic Pressure		←	←	Recorded at 30 Sec. intervals →			
Skin Temperature	*		*	*	*	*	*

* Thermographic determination of maximum right calf skin temperature

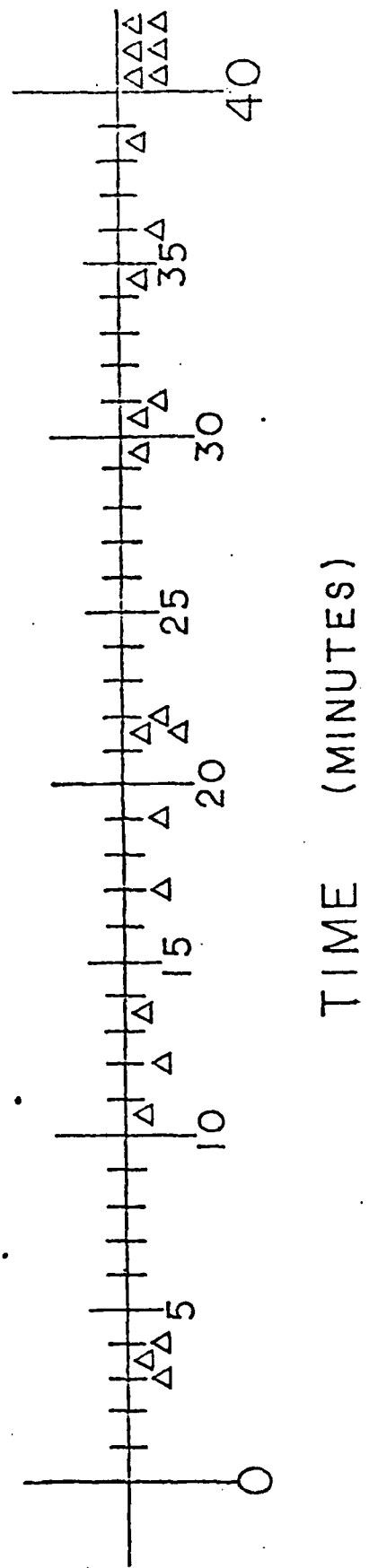
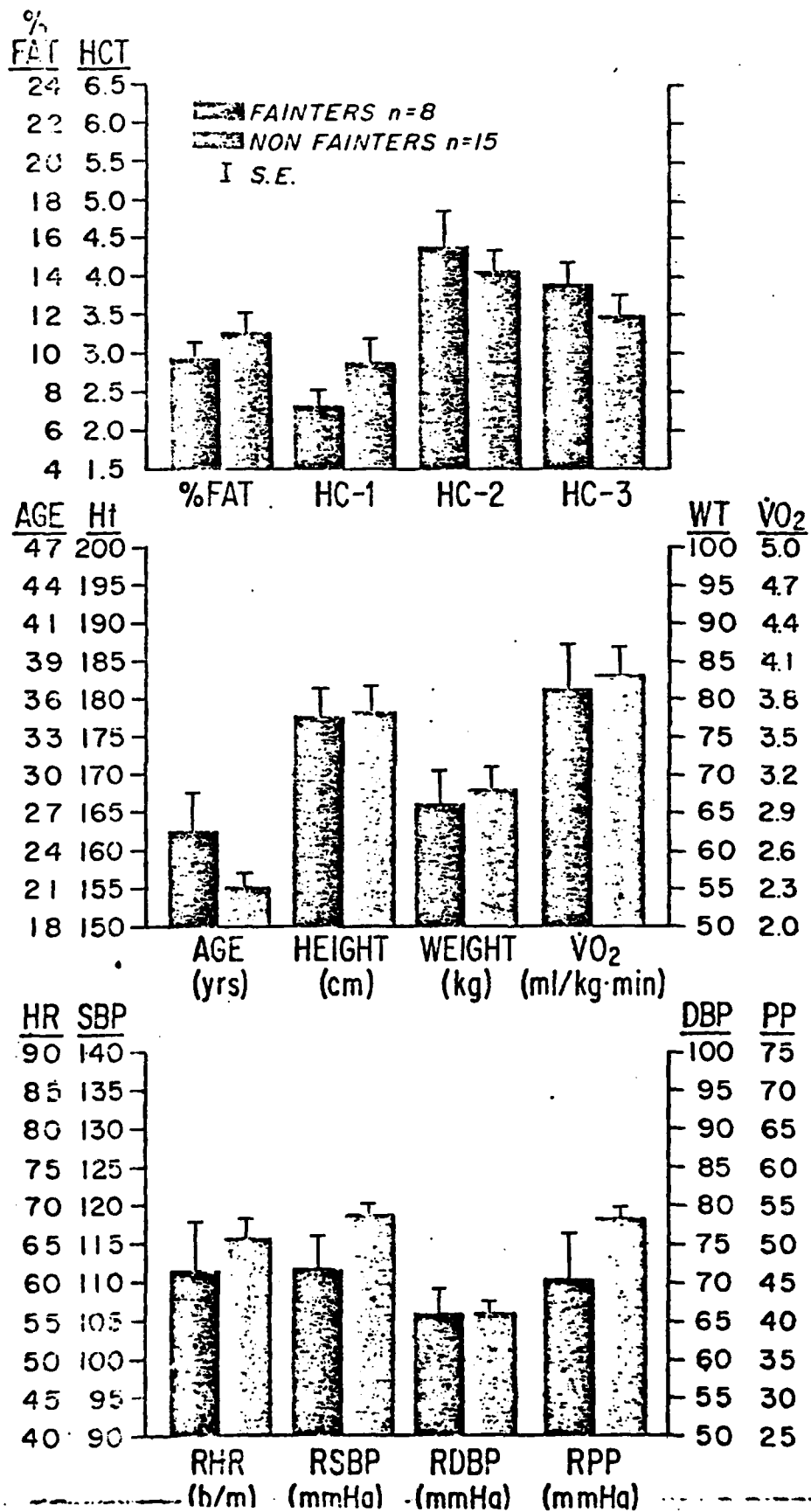

Figure 2. Time distribution of subject tilt tolerance to 40 minutes of 70° head-up tilt at 26° C ambient temperature.



FIGURE 3. PHYSICAL CHARACTERISTICS OF SUBJECTS
Fainters vs Non-Fainters for 20 Minute Dichotomy



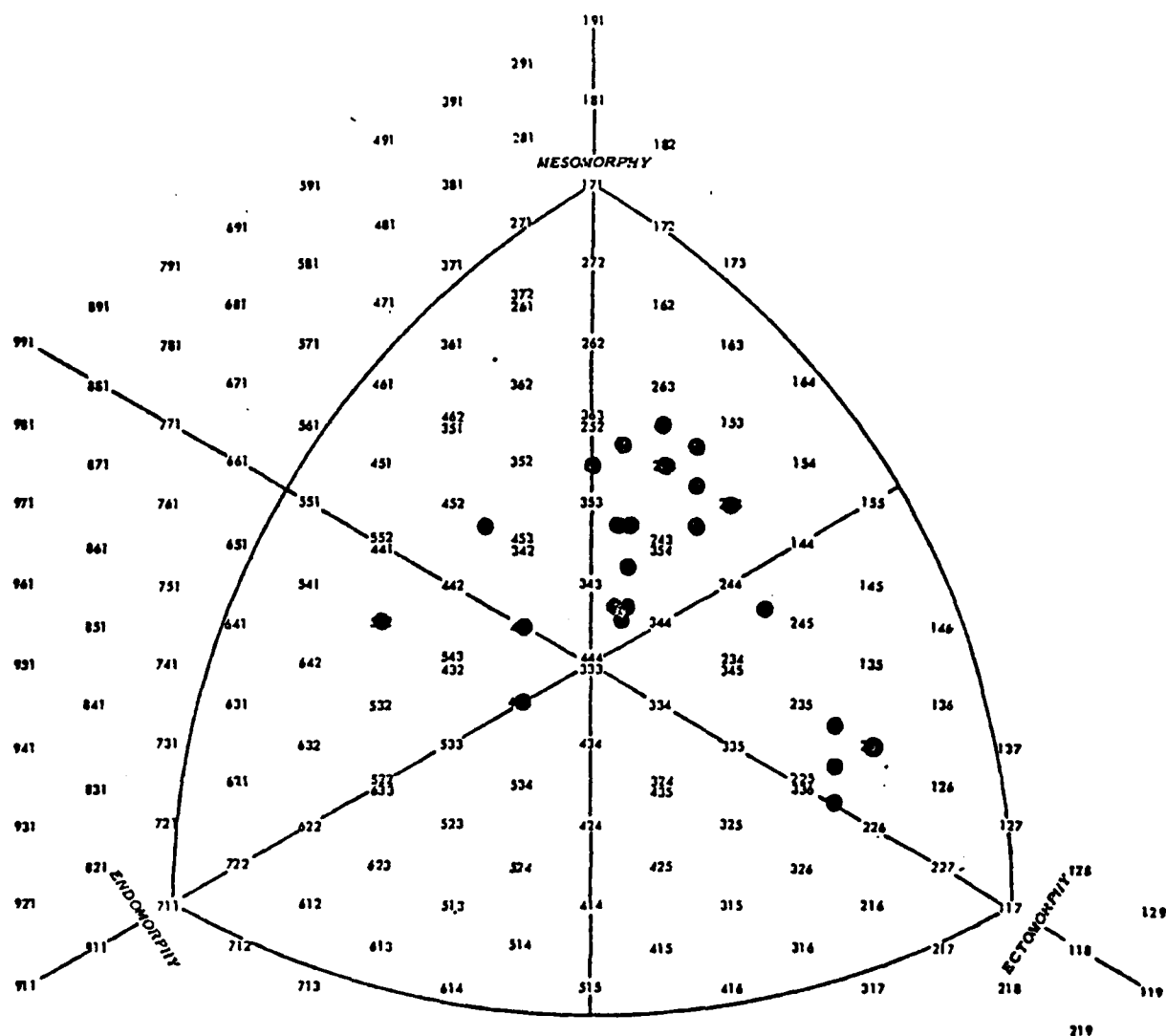
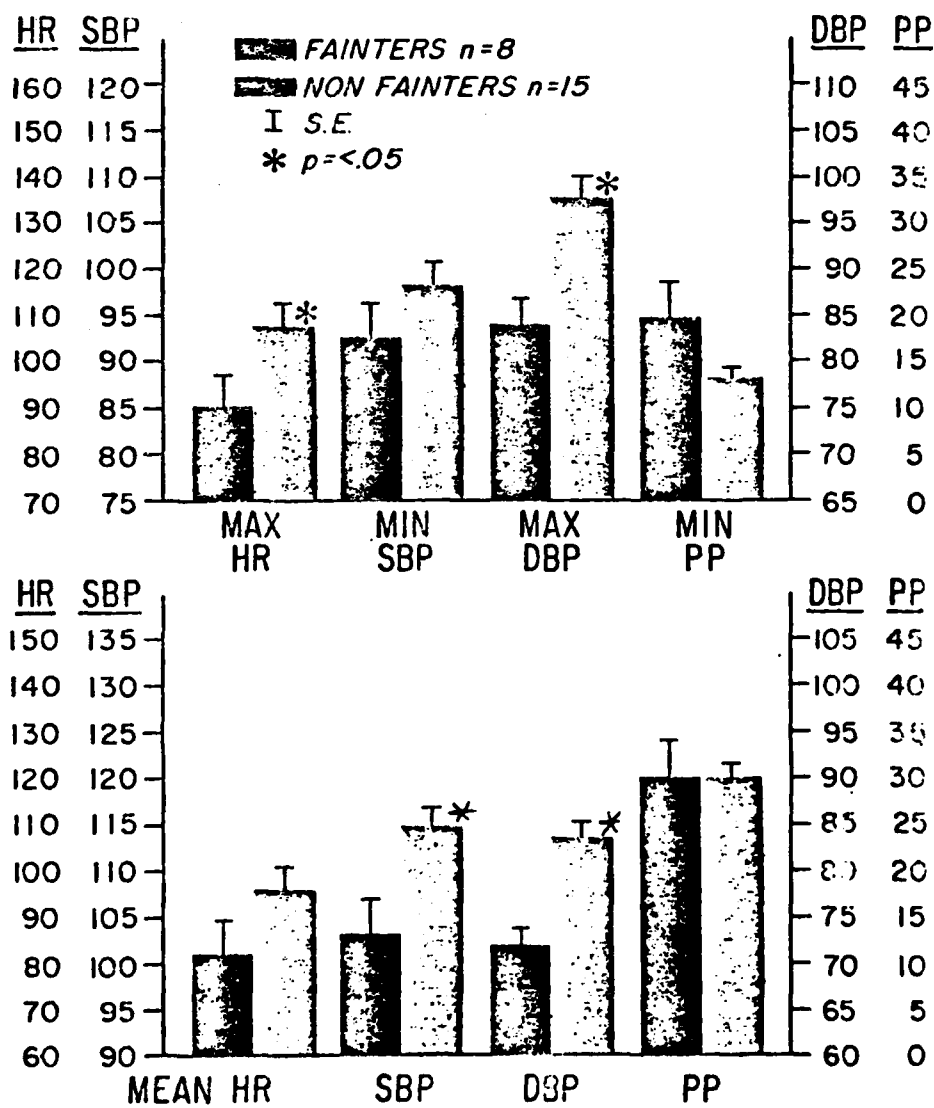

FIGURE 4. Anthropometric distribution of experimental subjects using the Heath-Carter Somatotype (20)

- Component 1: Refers to endomorphy or relative fatness and is determined from skinfolds.
- Component 2: Refers to mesomorphy or musculo-skeletal development and is determined from bone diameters and muscle girth.
- Component 3: Refers to ectomorphy or relative linearity and is determined from the ratio of height to the cube root of weight.

FIGURE 5. ORTHOSTATIC TOLERANCE OF EXPERIMENTAL SUBJECTS:
Fainters vs Non-Fainters for 20 Minute Dichotomy



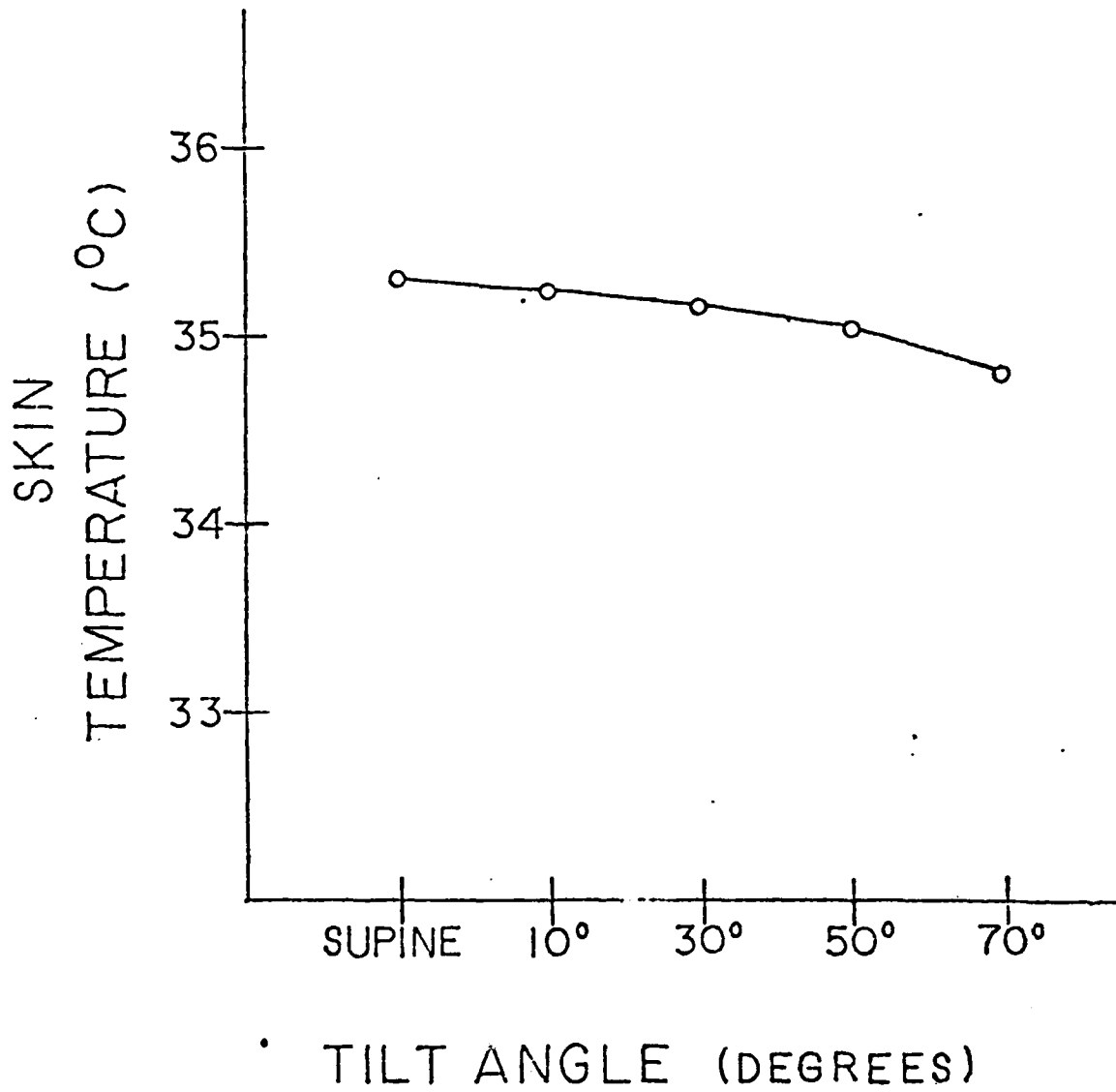

FIGURE 6. Mean right calf skin temperature maximum response to the dose-response tilt. Values are the means of 23 experimental subjects.

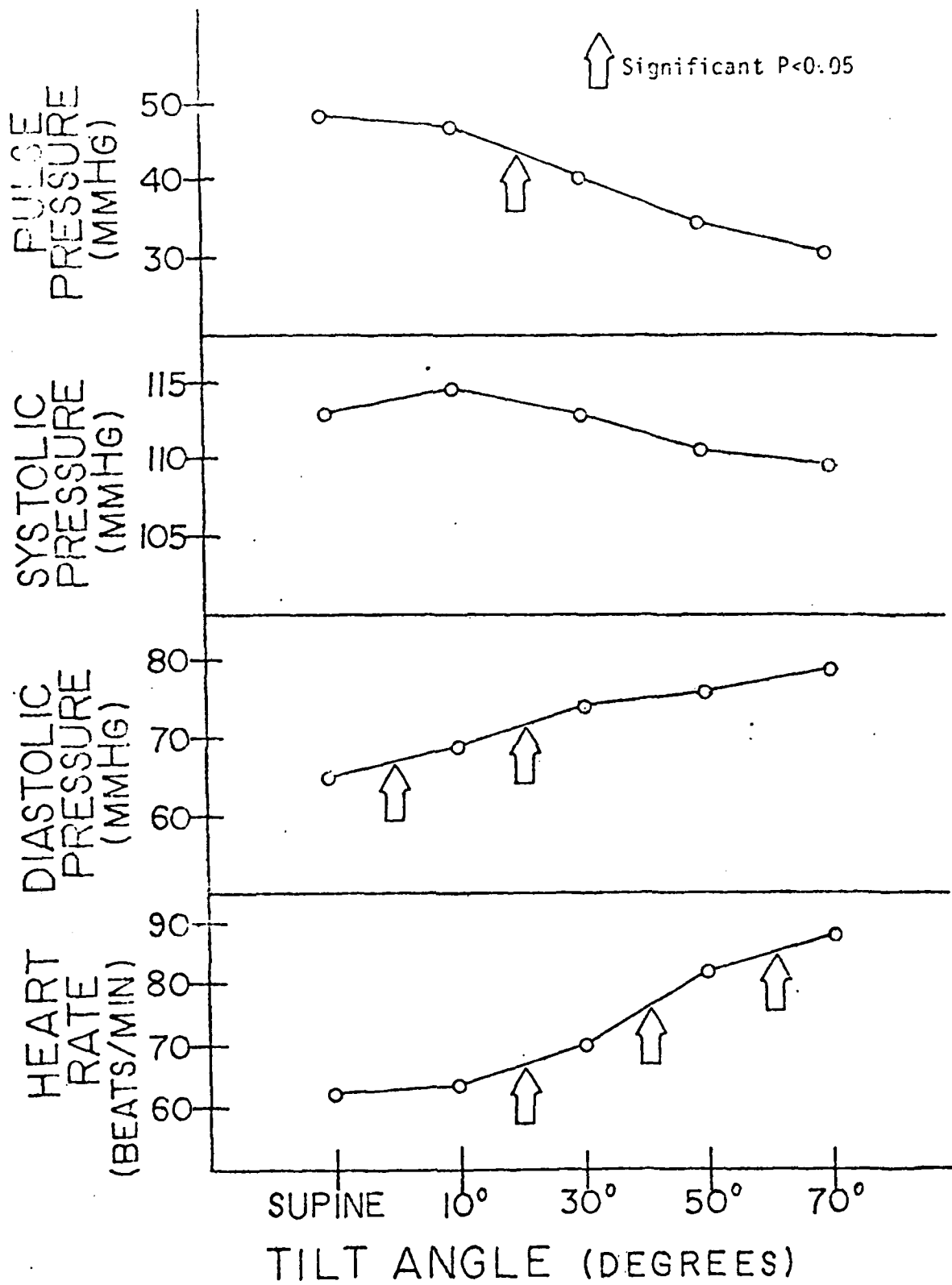

FIGURE 7. Mean cardiovascular response of experimental subjects to dose-response tilt.

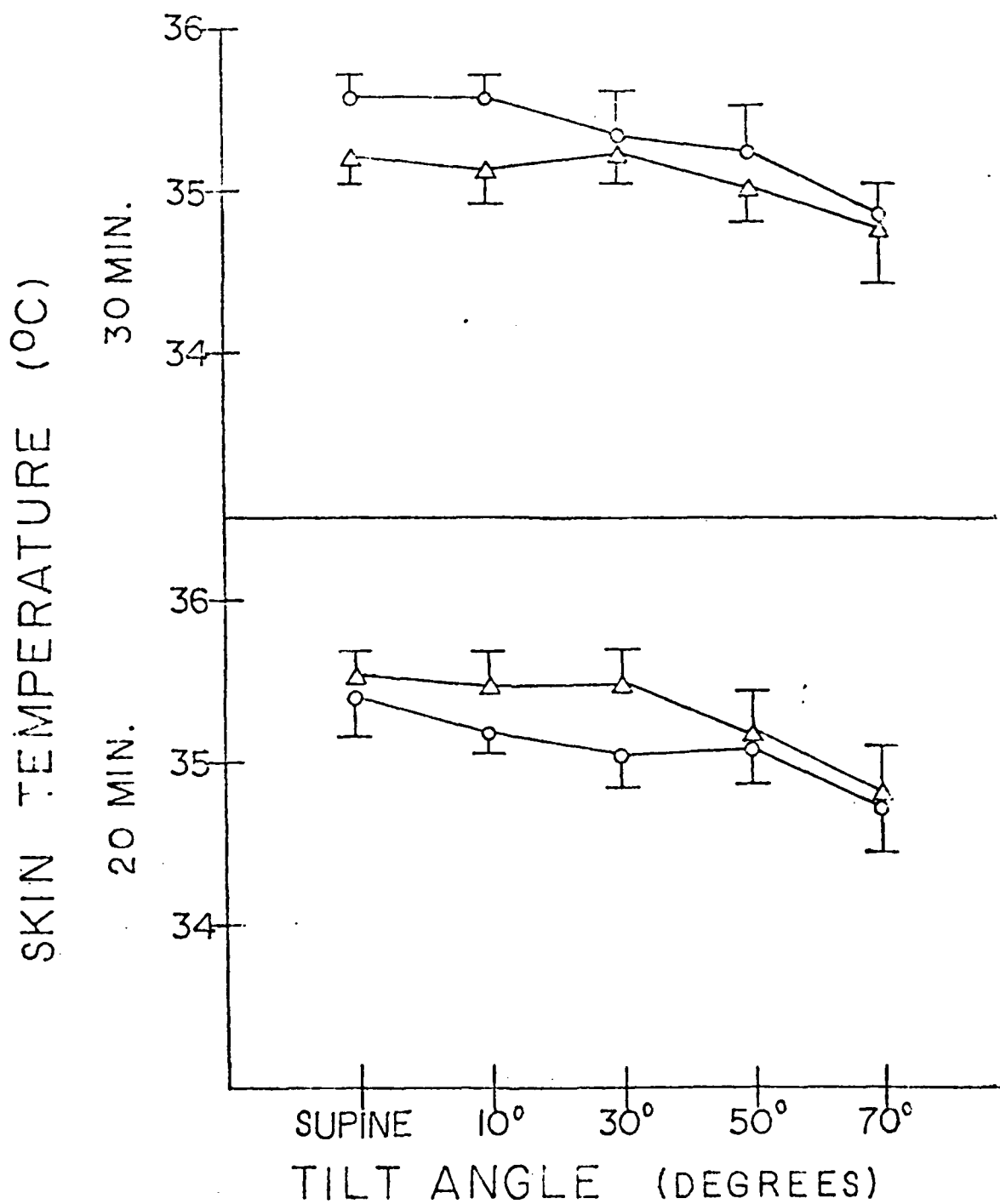

FIGURE 8. Right calf skin temperature maximum values for fainters \circ — \circ and non-fainters \triangle — \triangle at 20 minute and 30 minute dichotomy. Values are means \pm SE.

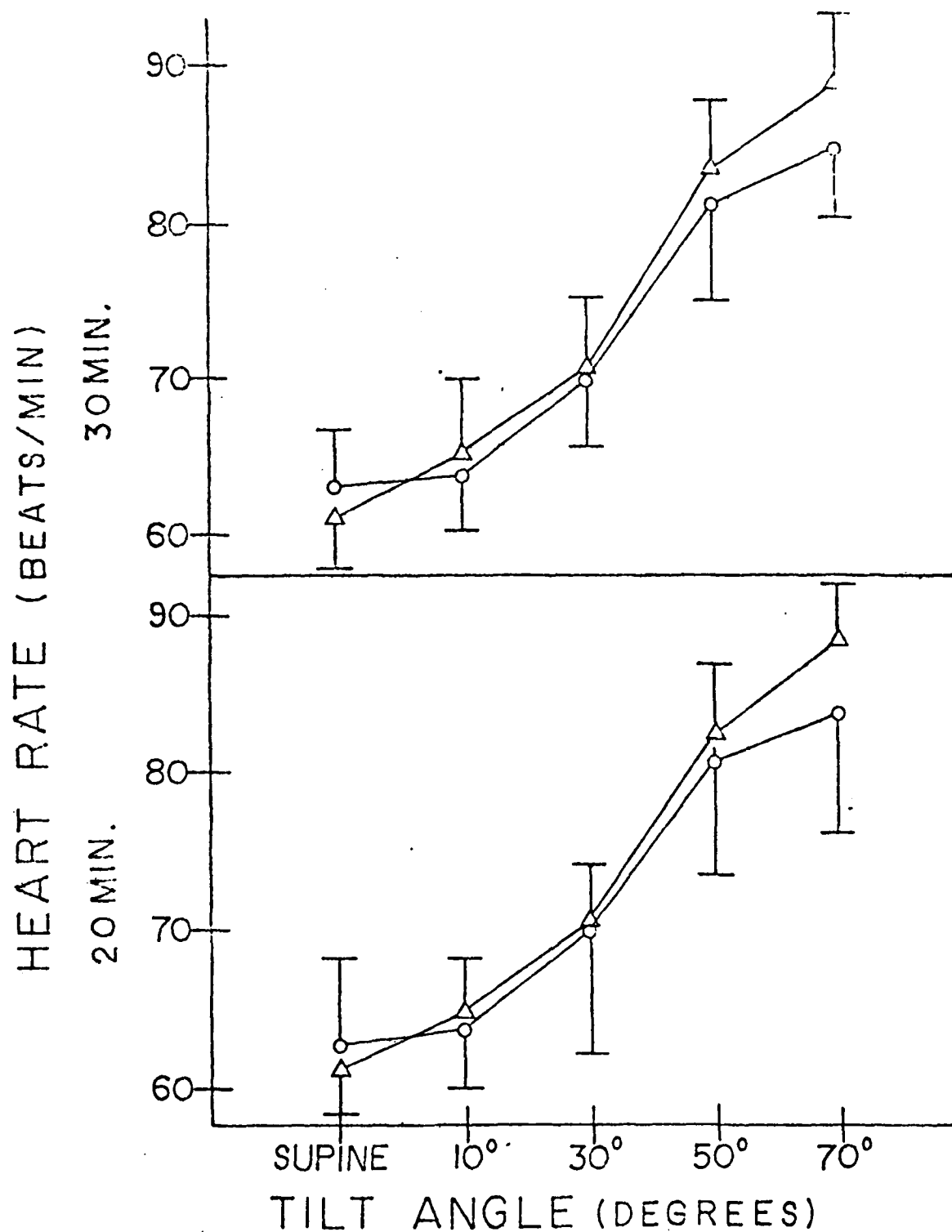

FIGURE 9. Heart rate values for fainters \circ — \circ and non-fainters \triangle — \triangle at 20 minute and 30 minute dichotomy. Values are mean \pm SE.

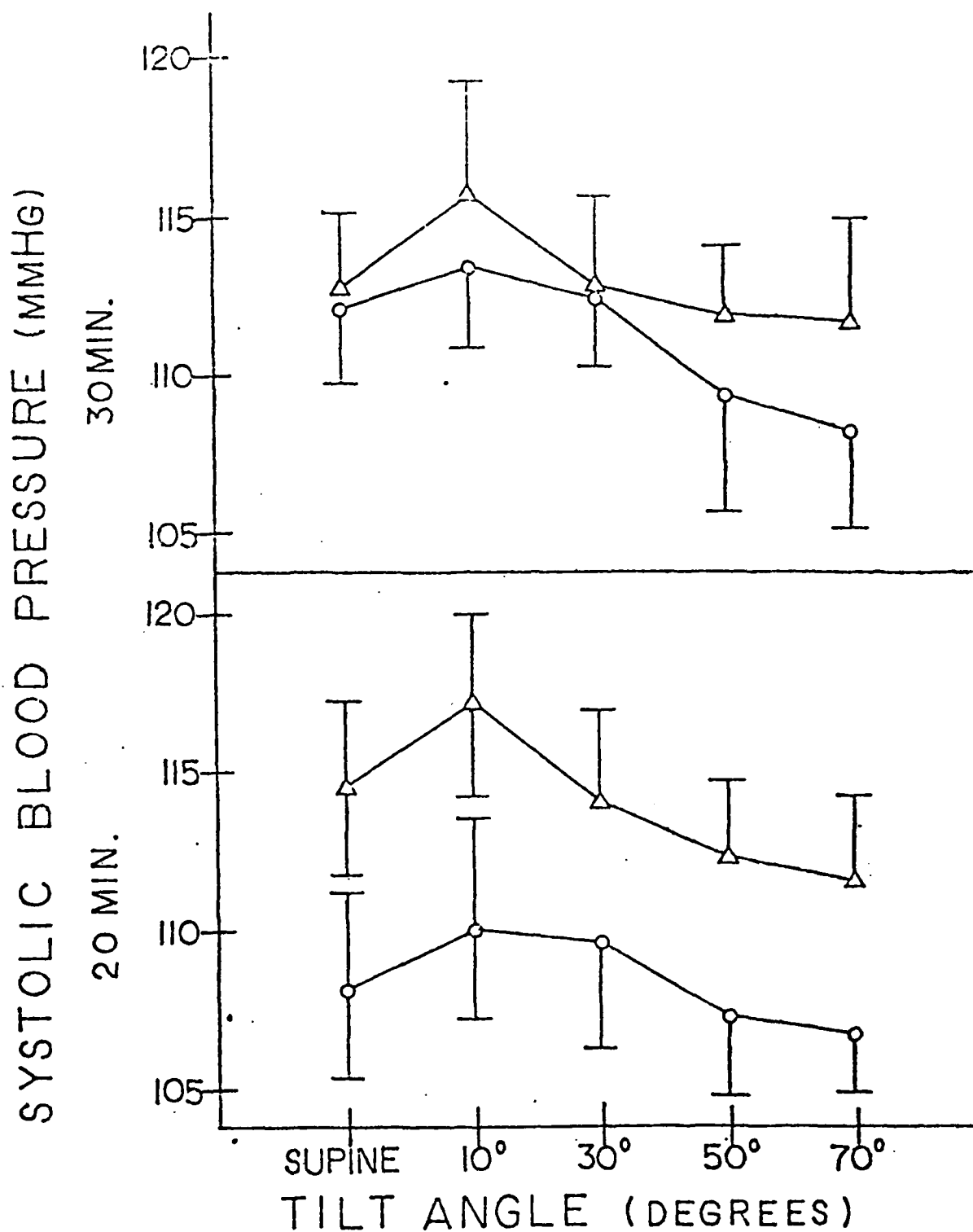

FIGURE 10. Systolic blood pressure values for fainters ○—○ and non-fainters △—△ at 20 minute and 30 minute dichotomy. Values are means \pm SE.

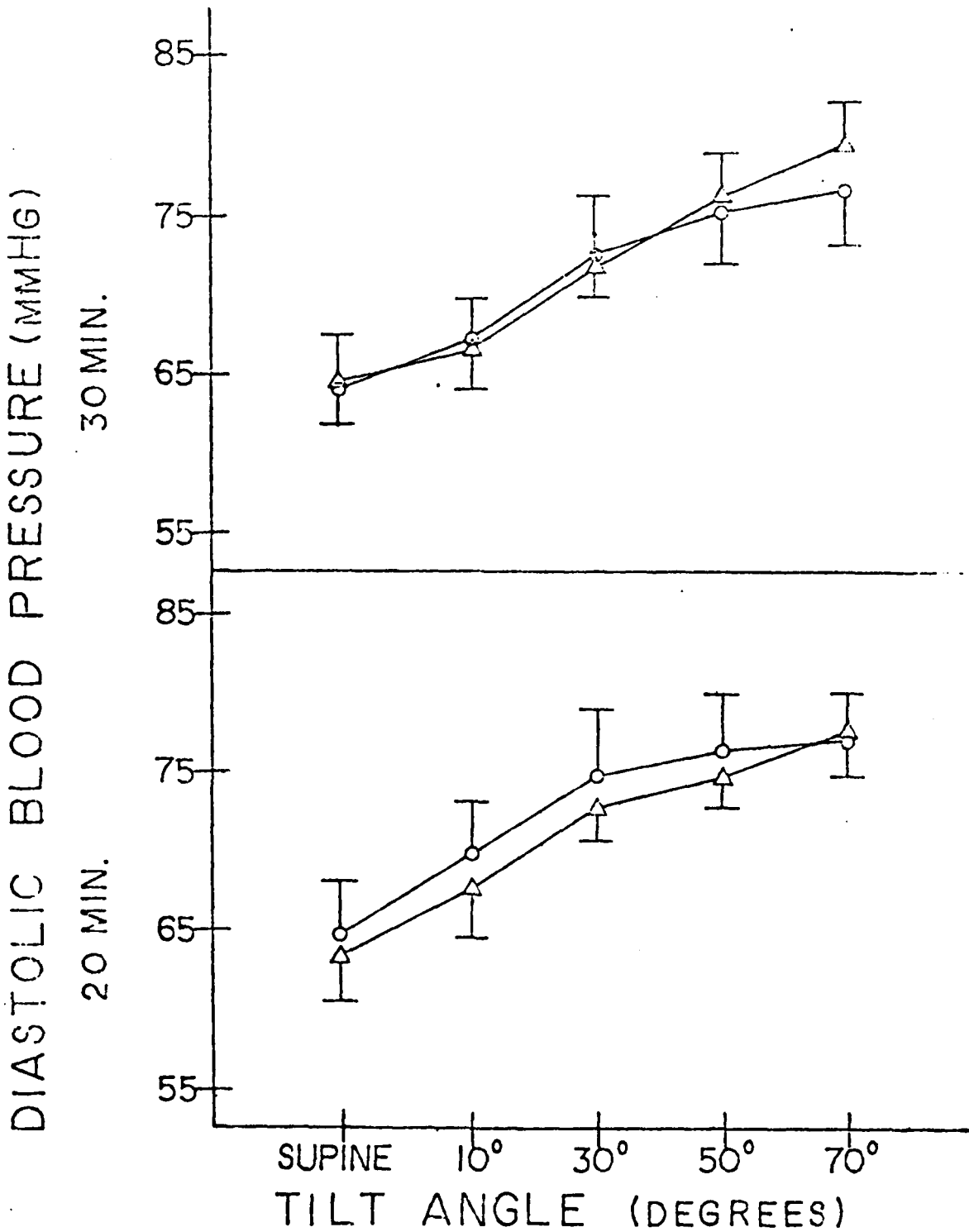

FIGURE 11. Diastolic blood pressure values for fainters ○—○ and non-fainters △—△ at 20 minute and 30 minute dichotomy. Values are mean ± SE.

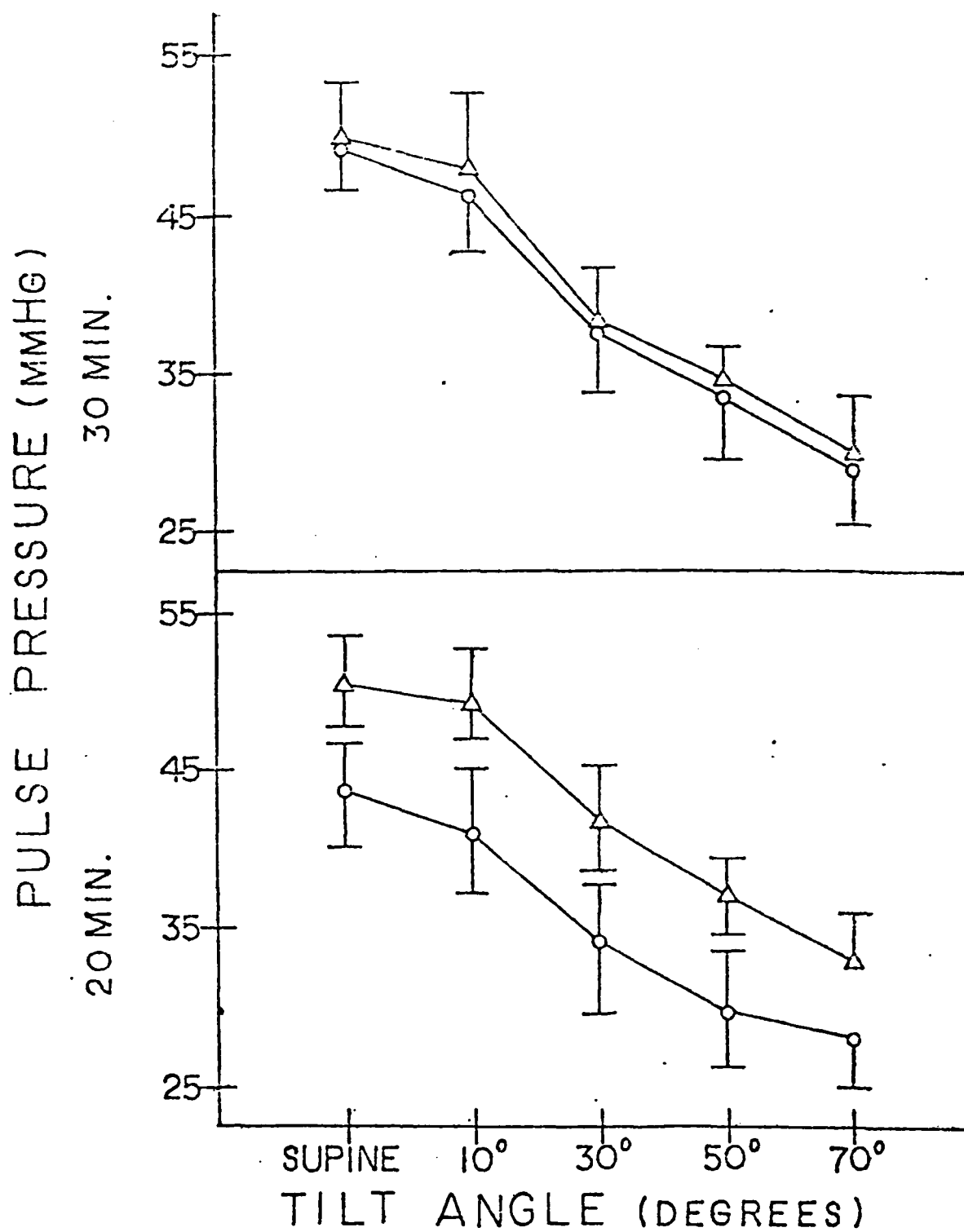

FIGURE 12. Pulse pressure values for fainters ○—○ and non-fainters △—△ at 20 minute and 30 minute dichotomy. Values are means \pm SE.

REPRINTS

Stremel, R.W., E.M. Bernauer, L.W. Harter, R.A. Schultz and R.F. Walters. Modeling static and dynamic human cardiovascular responses to exercise. Comp. Prog. in Biomed., 4:246-252, 1975.

Veghte, J.H., W.C. Adams and E.M. Bernauer. Temperature changes during exercise measured by thermography. Aviat., Space and Environ. Med., July:708-713, 1979.

Dressenforfer, R.H., C.E. Wade and E.M. Bernauer. Combined effects of breathing resistance and hyperoxia on aerobic work tolerance. J. Appl. Physiol.: Respirat. Environ. Exercise Physiol., 42(3):444-448, 1977.

Holly, R.G., J.G. Barnett, C.R. Ashmore, R.G. Taylor, and P.A. Mole. Stretch-induced growth in chicken wing muscles: a new model of stretch hypertrophy. Am. J. Physiol., 238(Cell Physiology 7):C62-C71, 1980.

Epperson, W.L., R.R. Burton and E.M. Bernauer. Influence of differential physical conditioning regimens on simulated aerial combat maneuvering tolerance. Aviat. Space and Environ. Med., Nov.:1091-1097, 1982.

END

FILMED

10-84

DTIC