

NO-A143 772

A DUAL DIGITAL TO VIDEO CONVERTER AND COLOR VIDEO
INSETTER FOR AVIONICS S. (U) ARMY AVIATION SYSTEMS
COMMAND ST LOUIS MO E A KARCHER ET AL. JUL 84
USRAVSCOM-TR-84-E-3

1/1

UNCLASSIFIED

F/G 9/5

NL



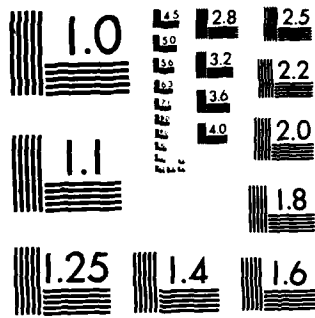

MICROCOPY RESOLUTION TEST CHART
NATIONAL BUREAU OF STANDARDS-1963-A

12

AVSCOM

Technical Report-84-E-3

A DUAL DIGITAL TO VIDEO CONVERTER AND COLOR VIDEO
INSERTER FOR AVIONICS SYMBOLOGY AND MESSAGES

EDWARD A. KARCHER
US ARMY AVIONICS R&D ACTIVITY

VINCENT J. ORGANIC
US ARMY ELECTRONICS R&D COMMAND

JULY 1984

DISTRIBUTION STATEMENT

Approved for public release;
distribution is unlimited.

AD-A143 772

DTIC FILE COPY



Research and Development Technical Report
Aviation Systems Command

100
21

21 00 01 21

NOTICES

Disclaimers

The citation of trade names and names of manufacturers in this report is not to be construed as official Government indorsement or approval of commercial products or services referenced herein.

Disposition

Destroy this report when it is no longer needed. Do not return it to the originator.

UNCLASSIFIED

SECURITY CLASSIFICATION OF THIS PAGE (When Data Entered)

REPORT DOCUMENTATION PAGE		READ INSTRUCTIONS BEFORE COMPLETING FORM
1. REPORT NUMBER AVSCOM TR-84-E-3	2. GOVT ACCESSION NO. AD-A243 772	3. RECIPIENT'S CATALOG NUMBER
4. TITLE (and Subtitle) A DUAL DIGITAL-TO-VIDEO CONVERTER AND COLOR VIDEO INSETTER FOR AVIONICS SYMBOLOGY AND MESSAGES		5. TYPE OF REPORT & PERIOD COVERED Technical Report
		6. PERFORMING ORG. REPORT NUMBER
7. AUTHOR(s) Edward A. Karcher (AVRADA) Vincent J. Organic (ERADCOM)		8. CONTRACT OR GRANT NUMBER(s)
9. PERFORMING ORGANIZATION NAME AND ADDRESS US Army Avionics R&D Activity (AVRADA) System Architecture & Engineering Division ATTN: SAVAA-F, Fort Monmouth, NJ 07703		10. PROGRAM ELEMENT, PROJECT, TASK AREA & WORK UNIT NUMBERS 612202.U84.X1.12
11. CONTROLLING OFFICE NAME AND ADDRESS US Army Avionics R&D Activity (AVRADA) System Architecture & Engineering Division ATTN: SAVAA-F, Fort Monmouth, NJ 07703		12. REPORT DATE July 1984
		13. NUMBER OF PAGES 15
14. MONITORING AGENCY NAME & ADDRESS (if different from Controlling Office)		15. SECURITY CLASS. (of this report) UNCLASSIFIED
		15a. DECLASSIFICATION/DOWNGRADING SCHEDULE
16. DISTRIBUTION STATEMENT (of this Report) Approved for public release; distribution is unlimited.		
17. DISTRIBUTION STATEMENT (of the abstract entered in Block 20, if different from Report)		
18. SUPPLEMENTARY NOTES		
19. KEY WORDS (Continue on reverse side if necessary and identify by block number) Video Display Television Display Scan Converter Color Insetting		
20. ABSTRACT (Continue on reverse side if necessary and identify by block number) This report describes the design, interface, and operation of a general purpose raster scan display digital-to-video converter and color video insetter which is capable of airborne or vehicular operation.		

TABLE OF CONTENTS

<u>Section</u>	<u>Page</u>
1. INTRODUCTION	1
2. SYSTEM DESCRIPTION	1
3. REQUIREMENTS	1
4. DESCRIPTION OF DIGITAL-TO-VIDEO CONVERTER	3
5. DESCRIPTION OF COLOR VIDEO INSETTER	3
6. FABRICATION	7
7. TEST RESULTS	7
8. CONCLUSIONS	10
ACKNOWLEDGEMENTS	10

Figures

1. Block Diagram of Typical Display System	2
2. Block Diagram of Digital-to-Video Converter	4
3. Block Diagram of Color Video Inserter	5
4. Digital-to-Video Converter/Color Inserter Front Panel	6
5. Digital-to-Video Converter/Color Inserter and Typical Circuit Cards	8
6. Typical Avionics Displays	9

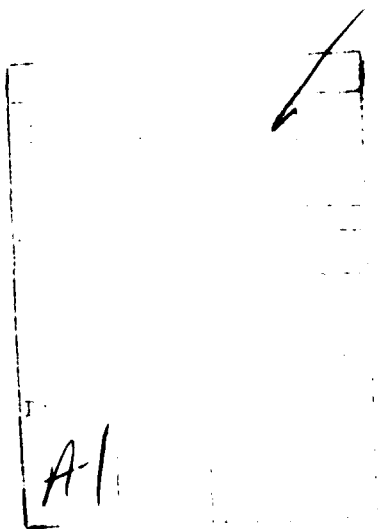

LIST OF ABBREVIATIONS AND ACRONYMS

AC	Alternating Current
ATR	Airborne Transportable Receptacle
AVRADA	Avionics Research and Development Activity
B&W TV	Black and White Television
DC	Direct Current
DEC	Digital Equipment Corporation
DR-11W	Direct Memory Access Module
DVC	Digital-to-Video Converter
GFE	Government Furnished Equipment
MUX	Multiplexer
RGB	Red, Green, Blue
TTL	Transistor Transistor Logic
TV	Television
VAX	Virtual Address Extension (DEC Trademark)

1. INTRODUCTION

This technical report describes a dual digital-to-video converter (DVC) capable of accepting computer data, storing it in memory, and reformatting it for display on a television screen.

If desired, two independent sets of data such as symbology and printed messages can be displayed simultaneously on different television monitors or combined on one monitor. The converter has its own video synchronization distribution circuitry, or can be synchronized externally.

In addition, an independent color video insetter is housed in the same enclosure. The color video insetter is capable of inseting data from two externally generated symbology sources (or from the DVC) into a red, green, blue (RGB) color video background. The two external sources can be independently adjusted to any color desired, from the front panel.

The equipment is intended for use in vehicular land navigation experiments. However, it is constructed so that it can be flown in an aircraft or can be used as a general purpose tool for avionics simulation work.

2. SYSTEM DESCRIPTION

A typical display system configuration is shown in Figure 1. Under control of the Virtual Address Extension (VAX) computer, the DVC formats the digital data into a television format for display. This data is then converted to a single color in the color insetter portion of the hardware or is displayed directly on a monochrome television monitor. The system configuration can be varied by appropriately patching the input and output video lines.

The DVC circuitry and color insetter circuitry were kept independent of each other to provide greater user flexibility. If desired, each portion can be used without regard to the other.

The DVC/color video insetter was designed and fabricated in-house and will be supplied to the contractor as Government Furnished Equipment (GFE) for integration into a vehicular land navigation system at the contractor's facility.

3. REQUIREMENTS

a. The DVC shall have two sets of ping-pong memories, each having independent data and display capabilities.

b. The DVC shall interface with a Digital Equipment Corporation (DEC) Direct Memory Access Module (DR-11W) type interface card as part of the DEC Unibus system. It shall also interface with a Singer SKC 2000 computer system. This is to be accomplished by utilizing interchangeable interface boards in the DVC.

c. The two independent display outputs shall each have a video output for directly driving a monochromatic TV monitor, as well as a Transistor Transistor Logic (TTL) output for inseting into another external video background.

d. The displayed area shall have a square format with a resolution of 256 bits per displayed line.

e. The DVC shall incorporate a built-in TV synchronization generator and also be capable of being synchronized from an external source.

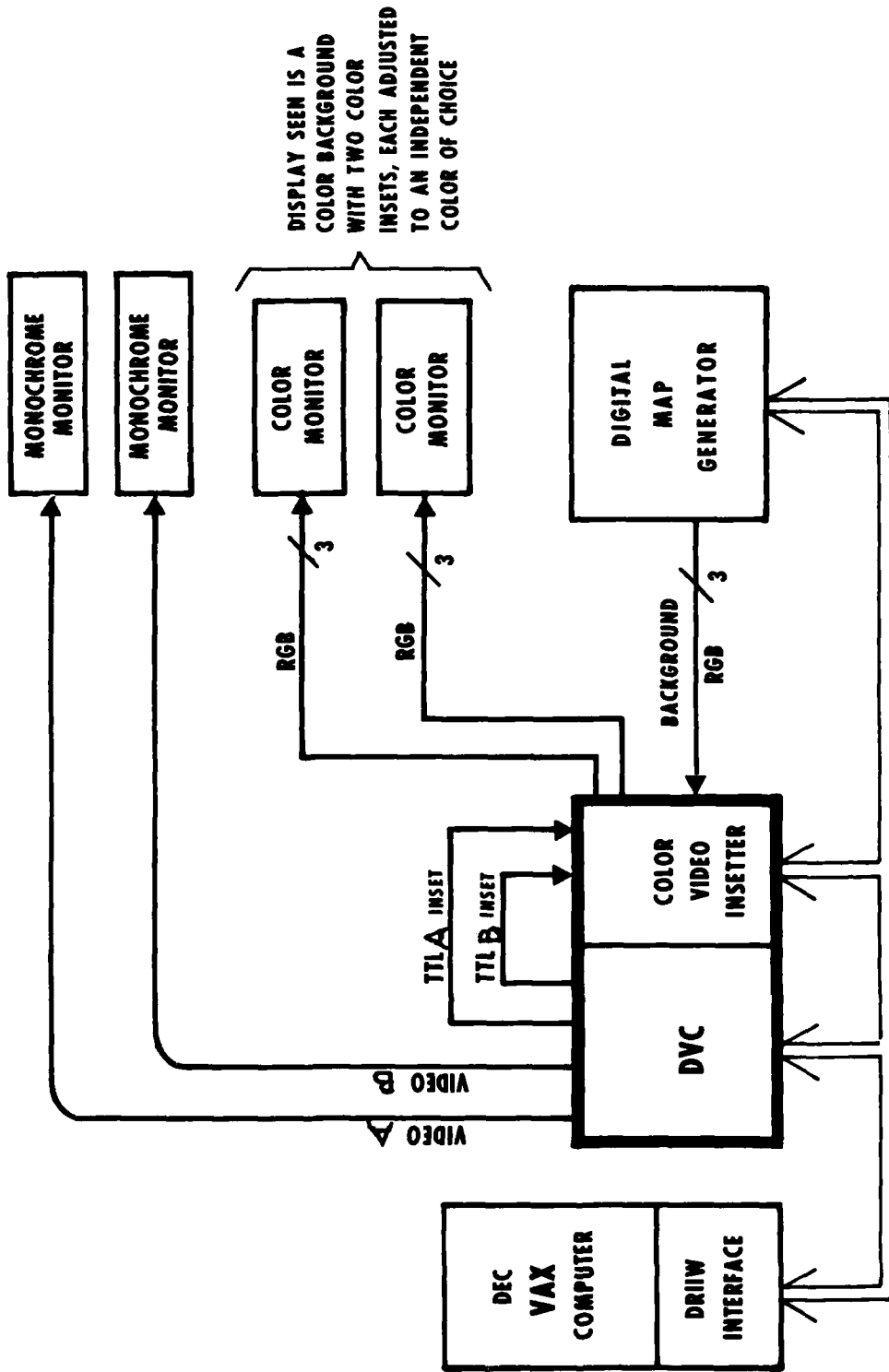

Figure 1. Block Diagram of Typical Display System.

f. A color video insetter shall be housed in the same enclosure but will operate in conjunction with, or independent of, the DVC portion of the hardware.

g. The color insetter shall inset into an RGB color video background two externally generated sources of symbology or messages. If desired, these can be connected through differential TTL twisted pair control lines and will be capable of being patched from the TTL outputs of the DVC portion. The color of each of the insets shall be independently determined by a set of potentiometers for the RGB primary colors located on the front panel.

h. If data from the A and B insets arrive simultaneously, the insetter will display data from the B inset source thus giving the B inset priority over the A inset.

i. Two identical video display outputs will be provided in an RGB format for the resulting combined video.

j. All inputs and outputs must be terminated in, or be capable of, driving 75-ohm loads.

k. Control of the insetter portion shall be from the front panel or by the VAX computer by utilizing two function bits. Panel control shall consist of having Insets Off, Select Inset A, Select Inset B, Select A and B, or Auto Control from the computer.

l. Although intended for vehicular use, construction shall be of airborne quality to permit installation on aircraft, if desired.

m. The equipment shall be powered by a 110-volt, 60-Hz modular supply which can be converted easily to 28-volt DC for aircraft use.

4. DESCRIPTION OF DIGITAL-TO-VIDEO CONVERTER

Figure 2 is a block diagram of the DVC. The DVC is covered in detail in AVRADCOM Technical Report 83-E-15, titled, "A Dual Digital-to-Video Converter for Avionics Symbology and Messages." The reader is referred to the referenced report for a detailed description of the DVC portion of this hardware.

5. DESCRIPTION OF COLOR VIDEO INSETTER

A block diagram of the insetter circuitry is shown in Figure 3. All input and output lines and control functions are located on the front panel. Two custom printed boards are used for all of the insetter circuitry. The display drivers are located on one circuit board and all of the other circuits are located on the other board.

The background video enters in a three-line RGB format and is fed through a display multiplexer to the display output drivers which provide two identical sets of RGB outputs capable of driving 75-ohm television monitors. The background inputs are located on the upper left portion of the front panel and the two sets of display outputs are located on the right portion (Fig. 4).

There are two sets of inset input signals, insets A and B. Both inset signals arrive as differential TTL and are terminated in balanced line receivers. The selection of insets to be displayed is controlled from a switch on the panel or by two control signals from the VAX computer. The final display can show no inset, inset

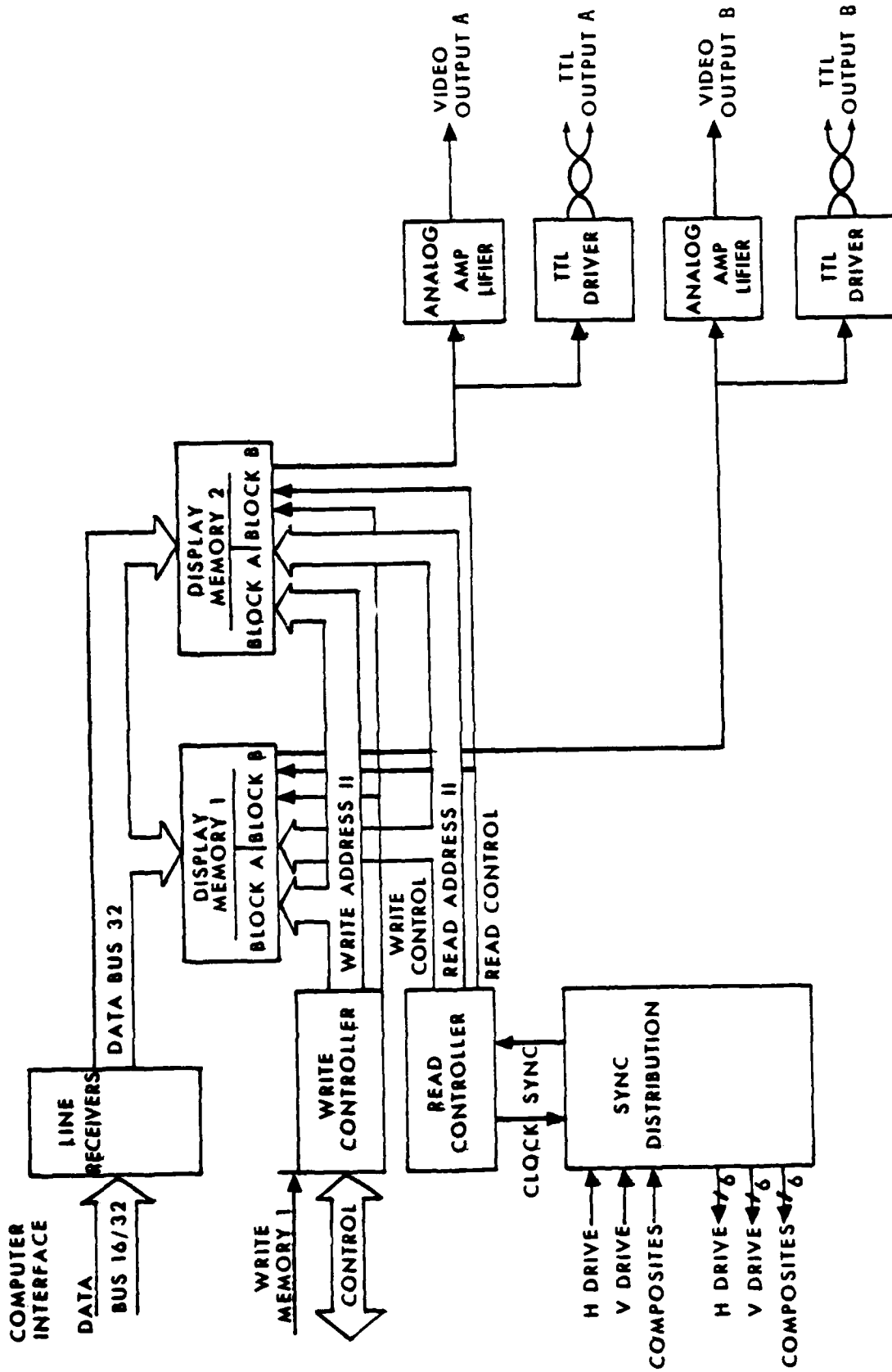

Figure 2. Block Diagram of Digital-to-Video Converter.

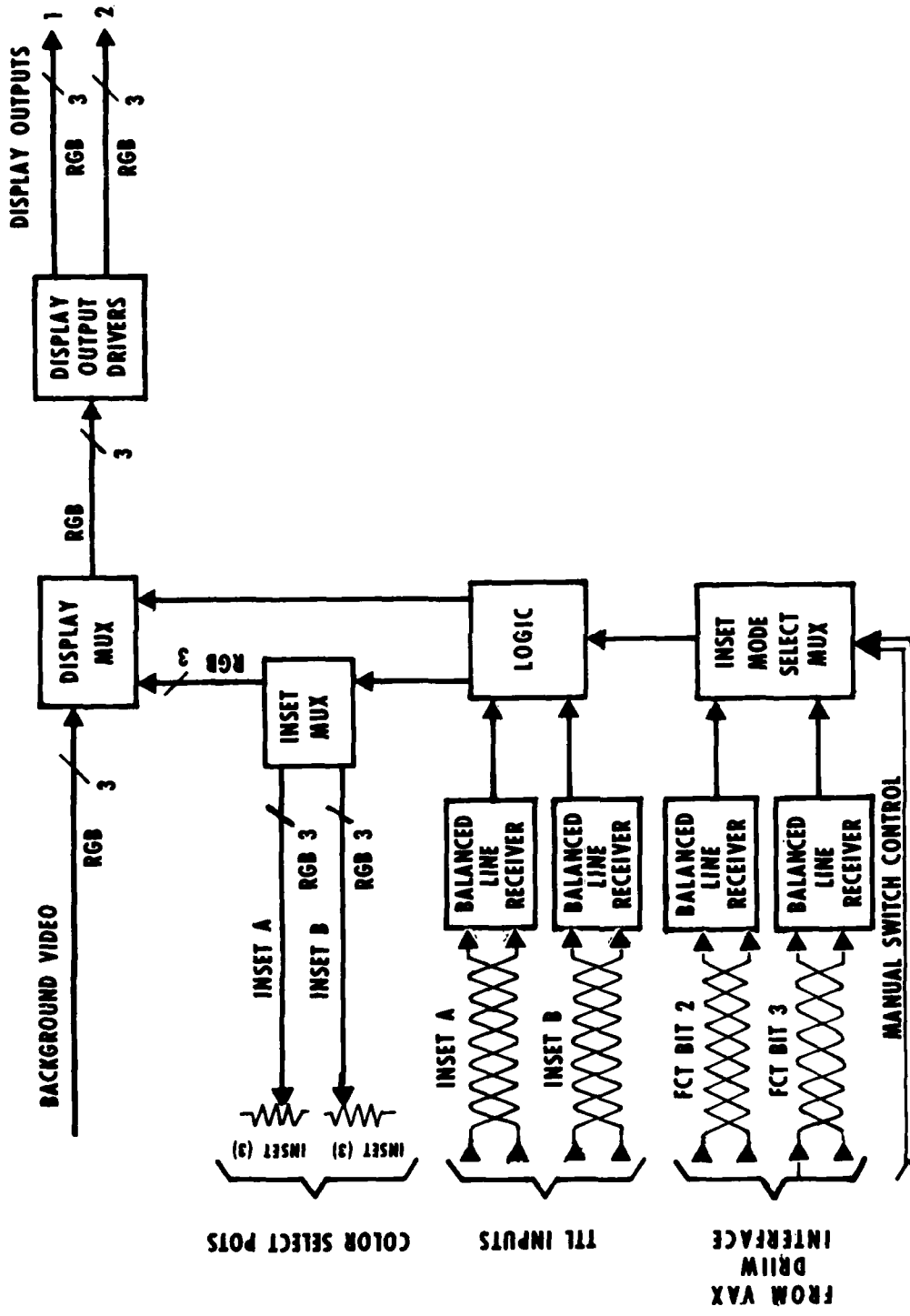

Figure 3. Block Diagram of Color Video Inserter.

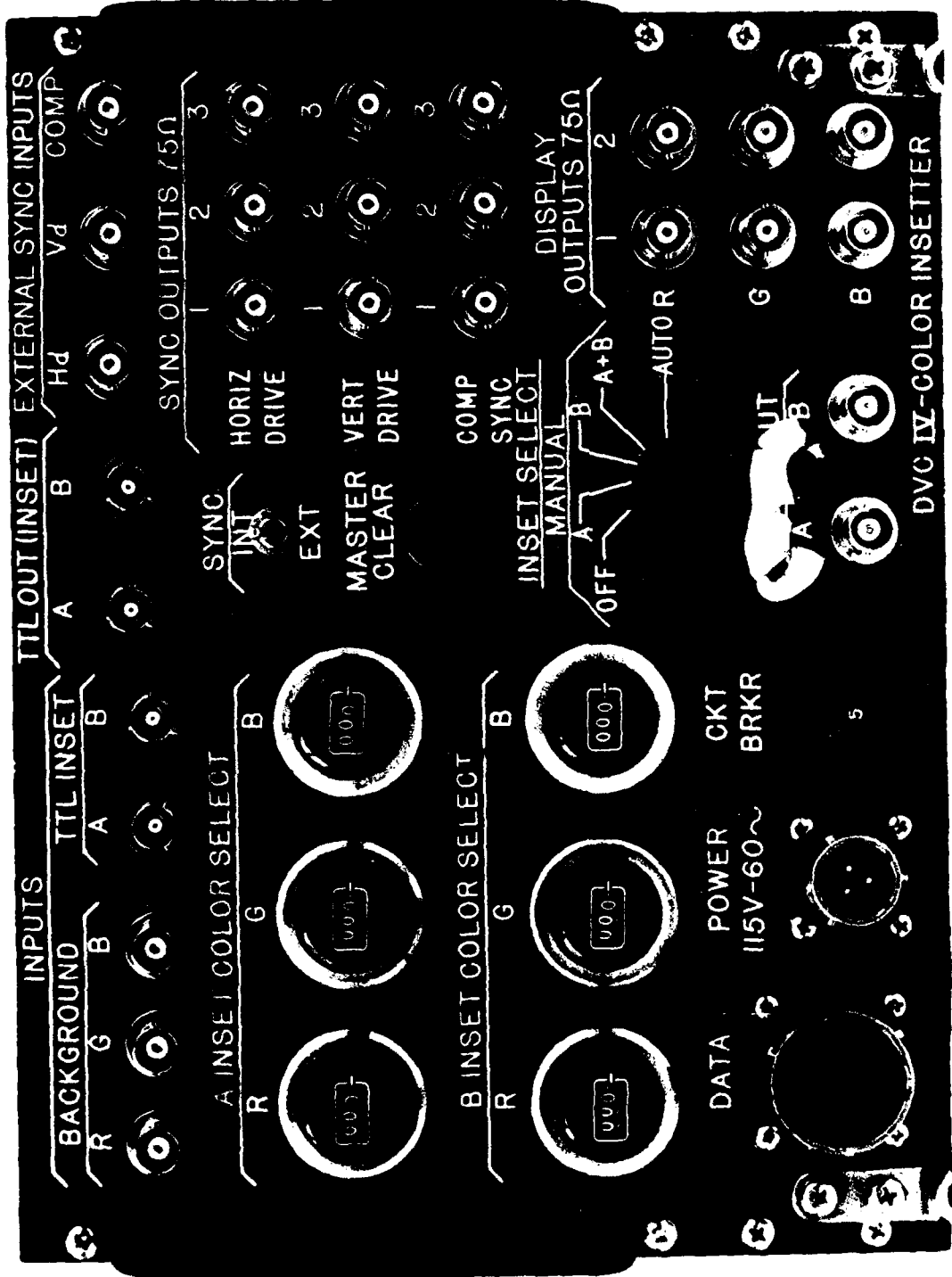

Figure 4. Digital-to-Video Converter/Color Inserter Front Panel.

A, inset B, or insets A and B. In the auto position, the VAX control signals replace the switch settings, thus providing the user manual or automatic operation of the insetter. If a VAX computer is not available, the insetter can be used as a stand-alone unit under manual switch control.

The inset signals are routed through logic, which, depending on the inset mode selected, routes the two sets of three-color-select potentiometers to the display multiplexer where the final selected inset mode is combined with the background video.

The color-select potentiometers are located on the left side of the panel. The selection of insets is accomplished in the inset multiplexer. When insets A and B are selected, the B inset has priority over the A inset thus insuring no color mixing that would result in non-pure inset colors. Upon command from the logic and inset multiplexer, the display multiplexer insets a fixed color onto the background video; the color being determined by the setting of the three-inset-color-select potentiometers for each of the inset inputs.

The insets can be set for any color desired by adjusting the appropriate RGB potentiometers. Digital-type readouts are used on the potentiometers so particular colors can be precisely repeated.

In monochrome (B&W) television work, mixing of the symbology with the background can often be used instead of the more complex RGB insetting since the inset symbol can be made more intense than the background and appears as one color (white). It can also be adjusted to have a transparent effect or be made black.

In color, any symbology or alphanumeric data must be inset to insure a uniform color for the data. Mixing the inset data with an RGB background would result in a new RGB signal; a horizontal line, for example, intended to be one color could have many colors depending on the background RGB video.

6. FABRICATION

A commercially available Airborne Transportable Receptacle (ATR) enclosure was used to house the circuit boards. A total of eight circuit boards were required. The digital circuitry was mounted on wire wrap boards and the analog circuitry was mounted on custom printed circuit boards. Figure 5 shows typical circuit boards. Commercially available linear and digital integrated circuits were used in each circuit board assembly. The front panel (Fig. 4) contains all input/output, power, and computer data connectors.

The power supply was fabricated with commercially available power modules and operates from a 120-volt AC, 60-Hz power source. However, due to the modular design, the power supply can be easily reconfigured with a 28-volt DC converter to permit operation onboard aircraft.

7. TEST RESULTS

The DVC/color video insetter was successfully operated in the laboratory and all design requirements were met. Figure 6 depicts some typical displayed data. The photographs in this report can only be shown in black and white; however, in actual use, the symbology would be set to any color desired and inset onto an RGB color map or camera background.

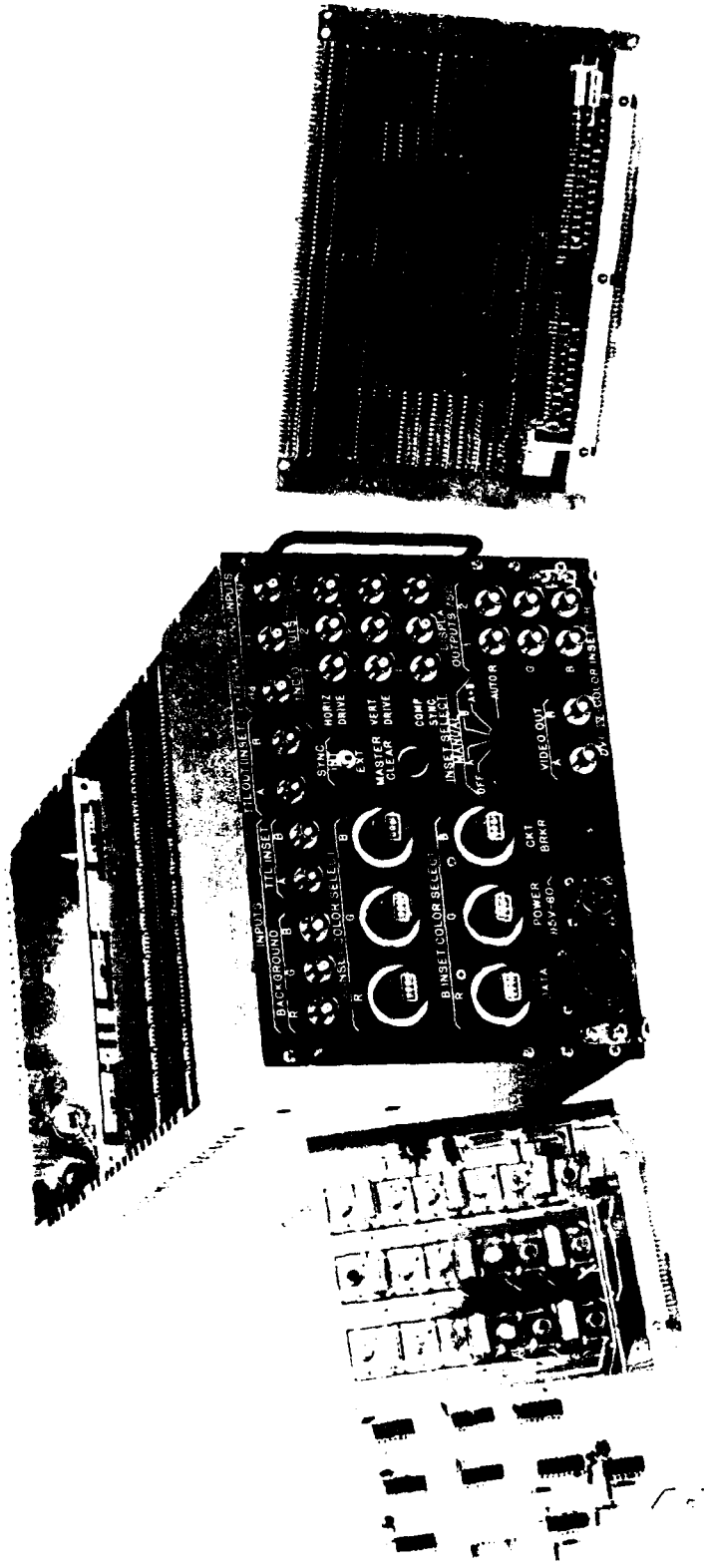
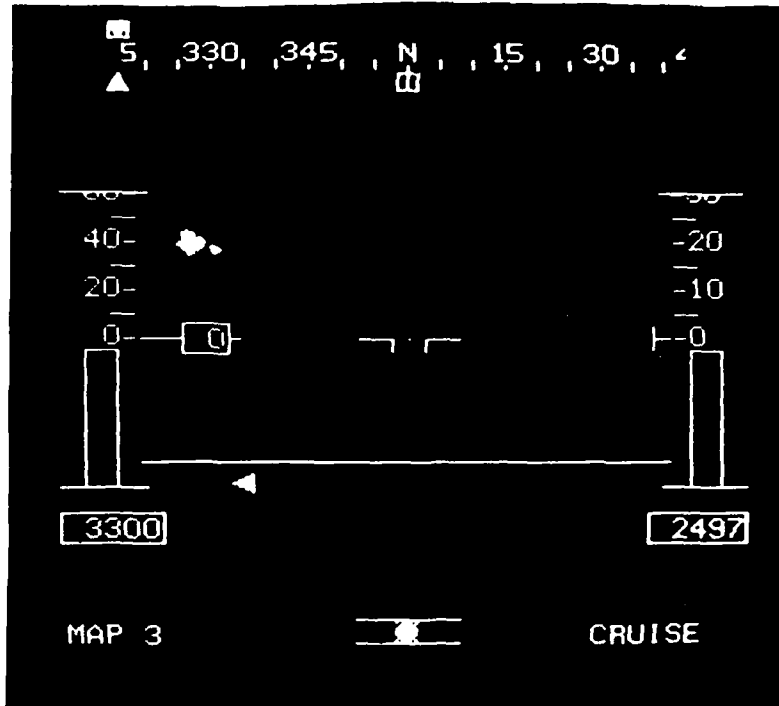

Figure 5. Digital-to-Video Converter/Color Inserter and Typical Circuit Cards.



DISPY 1 STATUS

 COPILOT'S QSWITCH SLOTTED SEQ -----
 1. PUSH TO CLR -- KEY IN NEW
 SEQUENCE (ANY LENGTH FROM 0 TO 7)
 2. PUSH TO SIGNAL END OF SEQUENCE

 3. PILOT'S SYMBOLS
 4. COPILOT'S SYMBOLS
 5. INPUT/OUTPUT
 6. MAP 1
 7. MAP 2
 8. MAP 1 + SYMBOLS
 9. MAP 2 + SYMBOLS

 0. RETURN

Figure 6. Typical Avionics Displays.

8. CONCLUSIONS

A general purpose DVC/Color inserter for raster scan displays has been designed and fabricated in-house. It is capable of airborne operation, although its present application will be in a land-based vehicle.

ACKNOWLEDGEMENTS

The authors wish to acknowledge the contributions of Mr. J. VanDover and Mr. D. Turner of the Electronics Technology and Devices Laboratory and Technical Support Activity, respectively, of ERADCOM for their assistance in the fabrication of circuit boards and assembly of the converter, and Mr. R. Kelly of Vitronics for generation of the software used in debugging the converter.

END

FILMED

9-84

DTIC