

AD-A142 727

MEASUREMENTS OF DISSOLVED GASES AT CORPS OF ENGINEERS  
PROJECTS(U) ARMY ENGINEER WATERWAYS EXPERIMENT STATION  
VICKSBURG MS HYDRAULICS LAB S C WILHELMS JUN 84  
WES/TR/HL-E-84-6

1/1

UNCLASSIFIED

F/G 13/2

NL



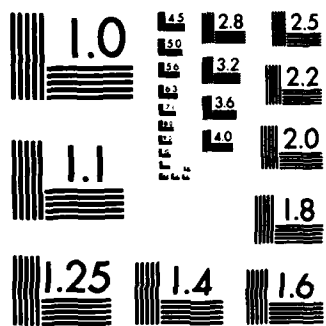

MICROCOPY RESOLUTION TEST CHART  
NATIONAL BUREAU OF STANDARDS-1963-A

12

ENVIRONMENTAL AND WATER QUALITY  
OPERATIONAL STUDIES

TECHNICAL REPORT E-84-6

MEASUREMENTS OF DISSOLVED GASES  
AT CORPS OF ENGINEERS PROJECTS

by

Steven C. Wilhelms

Hydraulics Laboratory

U. S. Army Engineer Waterways Experiment Station  
P. O. Box 631, Vicksburg, Miss. 39180

AD-A142 727

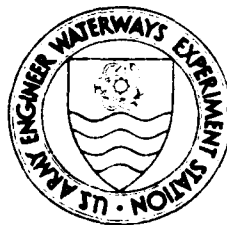

DTIC  
ELECTE  
JUL 5 1984  
S  
B

June 1984  
Final Report

Approved For Public Release. Distribution Unlimited

Prepared for Office, Chief of Engineers, U. S. Army  
Washington, D. C. 20314

Under CWIS 31042  
(EWQOS Work Unit 31604 (IIIA.1))

Monitored by Environmental Laboratory  
U. S. Army Engineer Waterways Experiment Station  
P. O. Box 631, Vicksburg, Miss. 39180

84 07 05 067



Destroy this report when no longer needed. Do not  
return it to the originator.

The findings in this report are not to be construed as an  
official Department of the Army position unless so  
designated by other authorized documents.

The contents of this report are not to be used for  
advertising, publication, or promotional purposes.  
Citation of trade names does not constitute an  
official endorsement or approval of the use of such  
commercial products.

Unclassified

SECURITY CLASSIFICATION OF THIS PAGE (When Data Entered)

| REPORT DOCUMENTATION PAGE  |  | READ INSTRUCTIONS<br>BEFORE COMPLETING FORM |
|--|--|---|
| 1. REPORT NUMBER<br>Technical Report E-84-6  | 2. GOVT ACCESSION NO.<br><b>AD-A142727</b>   | 3. RECIPIENT'S CATALOG NUMBER               |
| 4. TITLE (and Subtitle)<br>MEASUREMENTS OF DISSOLVED GASES<br>AT CORPS OF ENGINEERS PROJECTS   | 5. TYPE OF REPORT & PERIOD COVERED<br>Final report   |   |
|  | 6. PERFORMING ORG. REPORT NUMBER   |   |
| 7. AUTHOR(s)<br><br>Steven C. Wilhelms   | 8. CONTRACT OR GRANT NUMBER(s)   |   |
| 9. PERFORMING ORGANIZATION NAME AND ADDRESS<br>U. S. Army Engineer Waterways Experiment Station<br>Hydraulics Laboratory<br>P. O. Box 631, Vicksburg, Miss. 39180  | 10. PROGRAM ELEMENT, PROJECT, TASK<br>AREA & WORK UNIT NUMBERS<br>CWIS No. 31042<br>(EWQOS Work Unit 31604,<br>IIIA.1) |   |
| 11. CONTROLLING OFFICE NAME AND ADDRESS<br>Office, Chief of Engineers, U. S. Army<br>Washington, D. C. 20314   | 12. REPORT DATE<br>June 1984   |   |
|  | 13. NUMBER OF PAGES<br>26  |   |
| 14. MONITORING AGENCY NAME & ADDRESS (if different from Controlling Office)<br>U. S. Army Engineer Waterways Experiment Station<br>Environmental Laboratory<br>P. O. Box 631, Vicksburg, Miss. 39180   | 15. SECURITY CLASS. (of this report)<br>Unclassified   |   |
|  | 15a. DECLASSIFICATION/DOWNGRADING<br>SCHEDULE  |   |
| 16. DISTRIBUTION STATEMENT (of this Report)<br><br>Approved for public release; distribution unlimited.  |  |   |
| 17. DISTRIBUTION STATEMENT (of the abstract entered in Block 20, if different from Report)   |  |   |
| 18. SUPPLEMENTARY NOTES<br><br>Available from National Technical Information Service, 5285 Port Royal Road,<br>Springfield, Va. 22161.   |  |   |
| 19. KEY WORDS (Continue on reverse side if necessary and identify by block number)<br>Dissolved gases                                  Measurements<br>Dissolved nitrogen<br>Dissolved oxygen<br>Instruments   |  |   |
| 20. ABSTRACT (Continue on reverse side if necessary and identify by block number)<br><br>Instruments to measure dissolved gases were tested and evaluated under<br>field conditions. Limitations and potential problems with the various instru-<br>ments were discussed and recommendations were made.<br><br>For dissolved oxygen (DO) measurements, instruments that use polaro-<br>graphic probes were recommended. Chemical titration techniques were recom-<br>mended for probe calibration and spot-checking polarographic probe readings.<br>(Continued) |  |   |

Unclassified

SECURITY CLASSIFICATION OF THIS PAGE(When Data Entered)

20. ABSTRACT (Continued).

The D'Aoust Tensionometer and WES Saturometer were recommended for measurements to determine dissolved nitrogen (DN) concentrations. These techniques were recommended because they proved easy to use and were reasonably reliable under field conditions.

Although it provided simultaneous determinations of DO and DN, gas chromatography was not recommended for field measurements. The instruments were too sensitive to field handling, and results were very operator dependent.

Unclassified

SECURITY CLASSIFICATION OF THIS PAGE(When Data Entered)

## PREFACE

The need for evaluation and presentation of instrumentation and techniques to measure and predict concentrations of dissolved gases in water has long been recognized. Appropriate research and development has been encouraged by the Corps Committee on Water Quality and the Federal Interagency Steering Committee on Reaeration Research. The Ohio River Division (ORD), CE, hosted an interagency workshop on nitrogen supersaturation on 25 February 1979 to discuss, critique, and attempt to resolve problems involved in the measurement and prediction of dissolved gases in water. Mr. Glenn Drummond of ORD chaired the workshop and disseminated the results.

The measurement techniques discussed in this report have been used in various reservoir water quality field studies from 1978 to the present. The field studies were conducted by the Reservoir Water Quality (Physical) Branch (RWQB), Hydraulic Structures Division (HS) in the Hydraulics Laboratory (HL) of the Waterways Experiment Station (WES). Some field studies were funded through the Environmental and Water Quality Operational Studies (EWQOS) program; others were sponsored by CE District offices. The OCE Technical Monitors for EWQOS were Dr. John Bushman, Mr. Earl Eiker, and Mr. James L. Gottesman. Dr. Jerome Mahloch was the WES Program Manager of EWQOS.

The studies were directed by Messrs. H. B. Simmons, Chief of the HL, and J. L. Grace, Jr., Chief of the HS. Dr. Dennis R. Smith, Chief of the RWQB, supervised the efforts. Messrs. Charles H. Tate, Jr., Steven C. Wilhelms, and David H. Merritt of the RWQB helped to develop, refine, and/or field test the methods and systems described herein. Mr. Benjamin E. Beard of the Instrumentation Services Division of the WES designed the electronics of the WES saturometer. Mr. Wilhelms prepared this report.

COL Nelson P. Conover, CE, and COL Tilford C. Creel were Commanders and Directors of the WES during the studies. Mr. F. R. Brown was Technical Director.

This report should be cited as follows:

Wilhelms, S. C. 1984. "Measurements of Dissolved Gases at Corps of Engineers Projects," Technical Report E-84-6, U. S. Army Engineer Waterways Experiment Station, CE, Vicksburg, Miss.



CONTENTS

|   | <u>Page</u> |
|---|-------------|
| PREFACE . . . . .   | 1           |
| PART I: INTRODUCTION . . . . .  | 4           |
| Background . . . . .  | 4           |
| Objective and Scope . . . . .   | 5           |
| Gas Physics . . . . .   | 5           |
| PART II: MEASUREMENT TECHNIQUES . . . . .   | 8           |
| Dissolved Oxygen . . . . .  | 8           |
| Dissolved Nitrogen . . . . .  | 12          |
| Other Gases . . . . .   | 16          |
| PART III: DATA COLLECTION . . . . .   | 18          |
| Location and Frequency . . . . .  | 18          |
| Other Data . . . . .  | 18          |
| PART IV: CONCLUSIONS AND RECOMMENDATIONS . . . . .  | 20          |
| REFERENCES . . . . .  | 21          |
| PLATE 1   |             |
| APPENDIX A: FIELD CALIBRATION OF ELECTRONIC<br>D'Aoust TENSIONOMETER OR WES SATUROMETER . . . . . | A1          |

**S** DTIC ELECTE **D**  
 JUL 5 1984  
**B**

|                    |                                     |
|--------------------|-------------------------------------|
| Accession For      |                                     |
| NTIS GRA&I         | <input checked="" type="checkbox"/> |
| DTIC TAB           | <input type="checkbox"/>            |
| Unannounced        | <input type="checkbox"/>            |
| Justification      |                                     |
| By _____           |                                     |
| Distribution/      |                                     |
| Availability Codes |                                     |
| Dist               | Avail and/or Special                |
| A-1                |                                     |

DTIC  
COPY  
INSPECTED  
?

MEASUREMENTS OF DISSOLVED GASES AT  
CORPS OF ENGINEERS PROJECTS

PART I: INTRODUCTION

Background

1. Dissolved oxygen (DO) and dissolved nitrogen (DN) can present a paradoxical problem related to the quality of water released through hydraulic structures. In the summer, natural biological processes use oxygen in the lower levels of a lake. Typically, this oxygen is not replenished by reaeration at the water surface because downward mixing (and transport of oxygen) is impeded by the increase of water density due to thermal stratification with depth. Under these conditions, water with a low or zero DO content may be released if withdrawal is from deep in the lake (Bohan and Grace 1973). Low DO in the release is an important concern when such a condition is hazardous to aquatic life. Release DO may be improved in some instances by using reaeration techniques.

2. The paradox of oxygen and nitrogen uptake is that the same hydraulic conditions that promote large DO uptakes may also cause DN uptakes. This does not imply that enhancing the DO concentration necessitates large DN concentrations. It does indicate that the hydraulics of the reaeration process must be carefully designed, and for some existing structures that were designed such that the flow plunges, the structures should be carefully operated. Highly aerated plunging flows may produce large dissolved gas uptakes (Willis 1978; Smith 1974; and Boyer 1974). Very high levels of DN are hazardous to several fish species (Ebel 1969). At sufficiently high levels, this can cause "gas bubble" disease in fish, which can be fatal (Bouck 1980). Extremely high nitrogen concentrations are usually considered the cause of gas bubble disease (Dawley et al. 1975).

3. The gas-transfer characteristics of various hydraulic conditions must be evaluated to eliminate or decrease dissolved gas problem

areas. Physical models have been used to qualitatively evaluate changes in the gas-transfer characteristics of hydraulic structures due to changes in their hydraulic design (Wilhelms 1980; Edmister and Smith 1976). Numerical predictive techniques have also been developed (Buck, Miller, and Sheppard 1980; Wilhelms and Smith 1981) to aid in estimating the effects of a hydraulic structure on downstream dissolved gas. However, the usefulness of these techniques is predicated on the accuracy of the measured data that formed their bases. To evaluate the effectiveness of existing or new designs of hydraulic structures or to determine a desirable operational strategy for an existing or proposed structure relative to gas transfer, it is imperative that reliable measurement techniques be available. Whether measuring gas concentrations at existing projects or in physical models, the accuracy and precision of the measuring instrument or technique dictates the usefulness of the resulting data.

#### Objective and Scope

4. The purpose of this report is to present and evaluate techniques used to measure dissolved gases at CE projects (Duscha 1980). In-situ measurement equipment is described and evaluated. An off-site sample analysis technique is evaluated. Recommendations are made regarding measurement equipment, sampling locations and frequencies, and other data requirements.

#### Gas Physics

5. Gas transfer can be considered as two processes working together: molecular diffusion and turbulent dispersion (Tsivoglou and Wallace 1972). Molecular diffusion is a result of the inherent kinetic energy possessed by gas molecules. Turbulent dispersion is a result of the mixing due to the turbulence level in moving water. These two processes greatly influence the rate of gas transfer.

6. The force driving the gas transfer process is the difference in partial pressures of the gases in the water and the air at the

air-water interface. At thermodynamic equilibrium, no driving force exists and the net gas transfer is zero. Under this condition the water is considered "saturated." A measure of the force causing gas transfer is the "saturation deficit" and can be quantified with Henry's Law (Schroeder 1977)

$$C_{si} = k_i P_i \quad (1)$$

where

$C_{si}$  = saturation concentration for gas i

$k_i$  = proportionality coefficient for gas i

$P_i$  = partial pressure of gas i in overlying atmosphere

This simply states that water (at a given temperature) can contain an amount of dissolved gas that is linearly proportional to the partial pressure in the overlying atmosphere. The "saturation deficit" is the difference between the saturation concentration and the actual concentration.

7. Consider air bubbles near the surface of a water body. The ambient gas pressure is approximately atmospheric. According to Henry's Law, saturation conditions may be achieved with gas concentrations that are proportional to the partial pressures of the gases in the atmosphere. However, if air bubbles are at depth, hydrostatic pressure must be added to obtain the pressure of the gases in the bubbles. For instance, at a depth of 34 ft (10.4 m), the ambient pressure is twice that at the surface. Thus, the saturation concentrations for this thermodynamic state (at 34 ft (10.4 m)) are twice those at the surface. Obviously, in highly aerated plunging flows, the potential exists for gas concentrations to reach levels above these corresponding to saturation at atmospheric pressure; this is referred to as "supersaturation."

8. The gas transfer process is time dependent. Mathematically, it is usually expressed

$$\frac{C_s - C_f}{C_s - C_i} = \frac{D_f}{D_i} = e^{-Kt} \quad (2)$$

where

- $C_s$  = saturation concentration for thermodynamic state
- $C_f, C_i$  = final and initial gas concentration, respectively
- $D_f, D_i$  = final and initial saturation deficits, respectively
- $K$  = exchange coefficient for gas of interest
- $t$  = contact or travel time

With an infinite exchange coefficient or infinite contact time, the final deficit  $D_f$  approaches zero as  $C_f$  approaches the saturation concentration for the thermodynamic state. In most realistic flow regimes, the travel time and exchange coefficient have finite values that limit gas absorption. Very rarely would flow conditions occur that allow the dissolved gas concentrations to reach thermodynamic equilibrium at the higher (at depth) pressure.

## PART II: MEASUREMENT TECHNIQUES

9. For dissolved gases of any kind, the best measurement technique is in-situ rather than discrete sampling and subsequent analysis. In-situ measurement assures that the gas content of an undisturbed sample has been determined, whereas gas may be absorbed or lost during sampling, transport, or analysis with discrete sample analysis.

### Dissolved Oxygen

#### Polarographic probes

10. The most common method for DO measurement is a polarographic technique (YSI 1975; APHA, AWWA, and WPCF 1975) that uses an electrochemical probe. The probe consists of two metal electrodes in contact with an electrolyte separated from test water by a membrane (usually Teflon) permeable to oxygen. A polarizing voltage applied across the electrodes causes oxygen that has permeated the membrane to react at the cathode, causing an electrical current to flow. Oxygen passes through the membrane at a rate proportional to the partial pressure (and concentration) of oxygen in the water. If the partial pressure increases, more oxygen is passed through the membrane, resulting in increased current flow. The current flow is calibrated to correspond to a DO concentration.

11. Polarographic probes are very reliable, simple to operate and maintain, and relatively easy to calibrate. They are accurate to 1 percent of full scale or 0.1 mg/l. They may be calibrated with air or by titrametric methods. These instruments (Figure 1) usually consist of a surface unit for data readout and power, and a probe unit with cable for measurement at depth. Typically, these instruments have a thermistor for temperature measurement (a necessity for an adequate database) and a stirrer for moving water past the permeable membrane. Minimal personnel training for using these instruments is required.

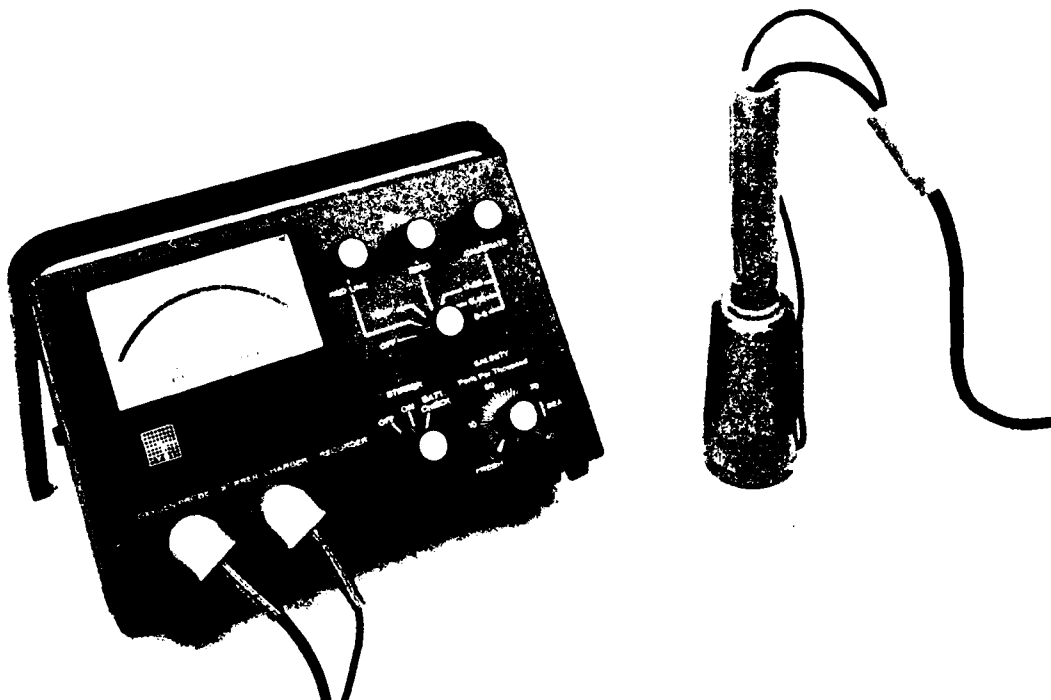

Figure 1. Polarographic dissolved oxygen probe and surface unit (Yellow Springs Instrument Company)

#### Chemical titrations

12. Another technique for DO measurement is a chemical method that uses an iodometric titration technique (Figure 2) (APHA, AWWA, and WPCF 1975; Hach 1976, 1978) to determine the oxygen content of a water sample. The method described is the azide modification of the Winkler titration technique. The test is based on the addition of a divalent manganese compound (manganese sulfate), followed by a strong alkali (alkaline iodide-azide), to the water sample. The chemical reaction results in divalent manganous hydroxide precipitate. The oxygen in the sample rapidly oxidizes an equivalent amount of the manganous hydroxide to hydroxides of higher valency states. Acidifying this solution with sulfuric or sulfamic acid results in the reversion of oxidized manganese to the divalent state, liberating an amount of iodine equivalent to the original DO content. The DO is determined by titrating the iodine

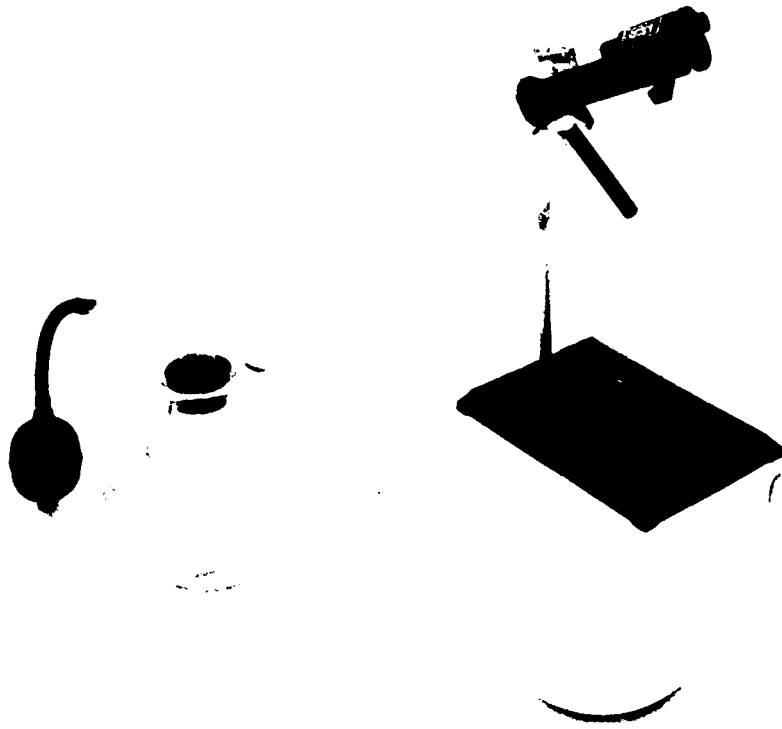

Figure 2. Equipment for chemical titration technique

in the solution to its end point with a standard solution of sodium thiosulfate or phenylarsine oxide.

13. This technique is relatively easy to use but is more time-consuming than polarographic probes. Typically, this method is used to calibrate and spot-check the polarographic technique. DO determinations with this method are very reliable and accurate; however, aging chemicals may produce erratic results that are not always obvious.

14. The equipment and chemicals needed for this technique are usually available through scientific equipment suppliers. Chemicals may be acquired in bulk or in kits of premeasured packets. The kits simplify usage; thus, personnel training is minimal. However, since a discrete sample is collected and analyzed, care must be exercised during handling to ensure that the sample is disturbed as little as possible.



### Gas chromatography

15. Another method is gas chromatography (McNair and Bonelli 1969; Thompson 1977). This technique employs either an in-laboratory or portable gas chromatograph (GC) (Figure 3). The technique is based on "sieving" component gases in a sample with a "molecular sieve" or absorbent polymer. The gas sample passes through a long tube (column) packed with a porous solid. The solid acts like a sieve, slowing the movement of larger diameter gas molecules or absorbing particular gases. This results in separation of the sample component gases of interest by the time the sample exits the column. The separated gases are directed to a detector, the output of which has been calibrated to correspond to an amount of gas. For oxygen, a thermal conductivity detector is integrated into the GC.

16. This equipment is much more complex (and much more expensive) than the polarographic or chemical titration techniques discussed

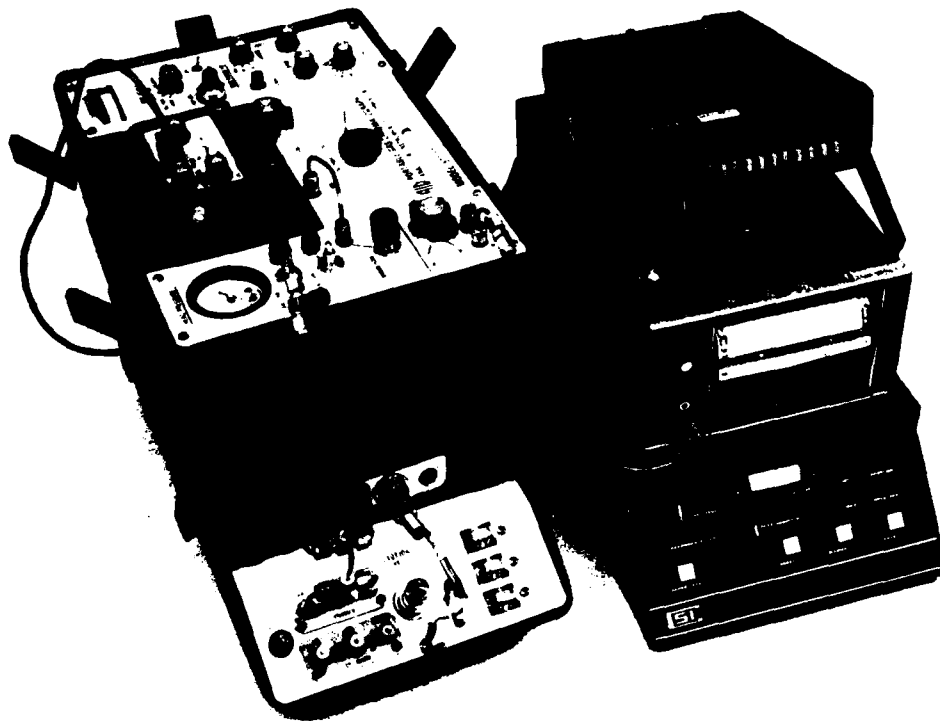

Figure 3. Portable gas chromatograph and peripheral equipment

previously. However, an added benefit is that DN is determined at the same time as oxygen. Because of its complexity, the GC is more susceptible to damage if mishandled than the other techniques. Personnel require a high degree of training and experience to properly operate a GC. Without proper sampling, handling, and chromatographic techniques (Leggett 1979), results can be extremely operator dependent. Maintenance may also be troublesome. The large number of tubing connections can result in almost undetectable gas leaks which may cause un dependable measurement. Septums wear out and must be replaced. Cylinder recharging with ultrapure gases (for analysis) must be done carefully to prevent contamination.

### Dissolved Nitrogen

#### Weiss saturometer

17. The Weiss saturometer (Fickeisen, Schneider, and Montgomery 1975) (Figure 4) is an instrument for indirectly determining DN concentration in surface water. This instrument is based on the principle that dissolved gas pressure will equilibrate across a permeable membrane. The Weiss saturometer consists of a length of gas-permeable tubing connected to a pressure gage.

18. When in the atmosphere, gas pressure in the tubing is equal to atmospheric; there is no net transfer of gas molecules through the tubing. The pressure gage indicates zero. After submerging the permeable tubing, gas transfer occurs through the wall of the tubing

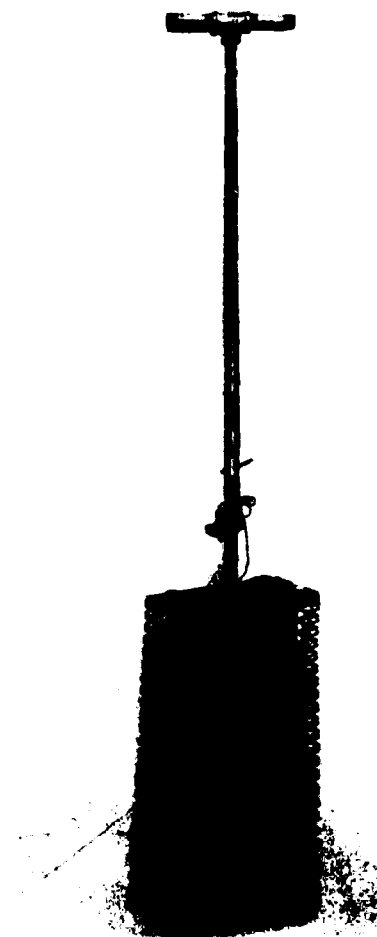

Figure 4. Weiss saturometer

until the pressure on the inside is equal to the total dissolved gas pressure in the water. If the water is supersaturated, gas molecules permeate the tubing, resulting in increased pressure in the tubing that is reflected by a positive pressure reading on the gage. If the water is undersaturated, gas molecules migrate through the tubing reducing the pressure. This is indicated by a negative (subatmospheric) pressure on the gage.

19. The Weiss saturometer measures total dissolved gas pressure in the water relative to atmospheric pressure. It does not differentiate between oxygen, nitrogen, or any other gases that may be in solution. To determine the DN content, the contribution of DO and water vapor to total gas pressure must be subtracted from the saturometer reading. Thus, DO must also be measured. The remaining pressure is assumed to be due to nitrogen, although small amounts of other gases are present, e.g., argon and carbon dioxide. With water temperature, DO, and atmospheric pressure, nitrogen saturation may be calculated from the following

$$DN_s = \left( \frac{P_{atm} + \Delta P - P_{H_2O} - 0.5320 \frac{DO}{BO}}{0.7902 (P_{atm} - P_{H_2O})} \right) 100 \quad (3)$$

where

$DN_s$  = nitrogen saturation (including argon), percent

$P_{atm}$  = atmospheric pressure, torr

$\Delta P$  = Weiss saturometer reading, torr

$P_{H_2O}$  = vapor pressure of water at observed temperature, torr

DO = measured DO, mg/l

BO = Bunsen coefficient for oxygen at observed temperature, per atm

0.5320 = factor to convert DO/BO ratio to pressure, torr/atm/mg/l

0.7902 = fraction of atmospheric pressure caused by nitrogen and argon

20. The Weiss saturometer is reliable and easy to use, but application is limited. Only surface measurements can be made since the instrument is hand-held with a short handle. This limitation is necessary because of the physical connection (impermeable tubing) between the sensing tubing and the pressure gage. Very long equilibration time would be required (because of the increased volume) if the connecting tubing were long enough to permit measurements at depth.

D'Aoust tensionometer

21. The D'Aoust tensionometer (D'Aoust, White, and Seibold 1976; D'Aoust and Clark 1980) (Figure 5) operates on the same principle as the Weiss saturometer. The pressure gage is replaced by an electronic pressure transducer, which is positioned in a probe assembly very close to the sensing tubing. This proximity results in reduced equilibration time (lower volume in system). Measurements may be made at depth and electrically transmitted to the data processing system and power supply at the surface.

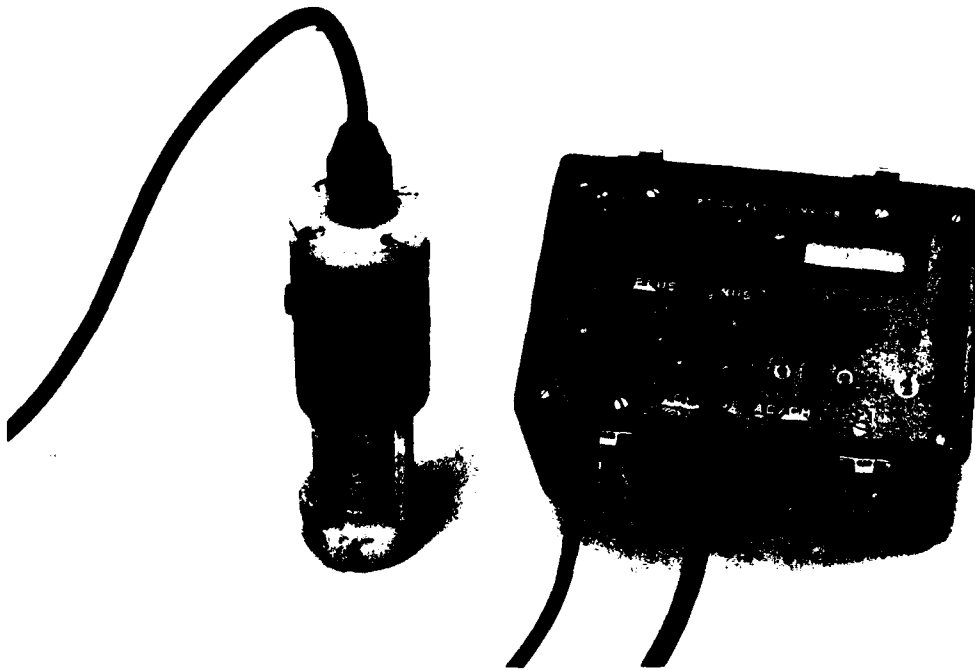

Figure 5. D'Aoust tensionometer

22. Typically, tensionometer output is in absolute pressure. In the atmosphere the tensionometer would indicate atmospheric pressure (in torrs) rather than zero (which is gage pressure) as with the Weiss saturometer. For data analysis, tensionometer measurements are the sum of the atmospheric pressure and total dissolved gas pressure. Thus, the readings represent  $P_{atm} + \Delta P$  in Equation 3.

23. The tensionometer can be a reliable instrument if care is exercised during handling. Temperature and environmental extremes should be avoided since they may affect the electronics in the surface unit. As with the Weiss saturometer, temperature and DO measurements must be made in conjunction with tensionometer readings. In some models a thermistor was included, but in the initial design its accuracy was inadequate. It is the author's understanding that recent design changes have alleviated these thermistor and environment-sensitivity problems and an improved model is available. A calibration technique for the tensionometer is presented in Appendix A.

#### WES saturometer

24. The Waterways Experiment Station (WES) saturometer (Figure 6) is very similar to the tensionometer in concept. It uses an electronic pressure transducer connected to gas-permeable tubing for dissolved gas pressure readings. Additionally, a Yellow Springs Instrument Company (YSI) DO/temperature sensor and stirrer are integrated into the saturometer probe assembly. A single high-grade multistrand underwater cable carries power and return signals between the probe assembly and a weather-proofed surface unit. Power, signal conditioning, and readout for dissolved gas pressure are contained in the saturometer surface unit. Signal and power for the DO/temperature sensor are passed on to an ordinary YSI surface unit for display.

25. Simplified and more reliable electronics are employed for signal conditioning for pressure measurement. An internal electronic check circuit is included in the design to verify that the circuitry is functioning properly. Plate 1 is a schematic of the improved electronics of the WES saturometer. An internal Gel Cell battery provides power for the saturometer with an external AC/DC powerpack for simultaneous

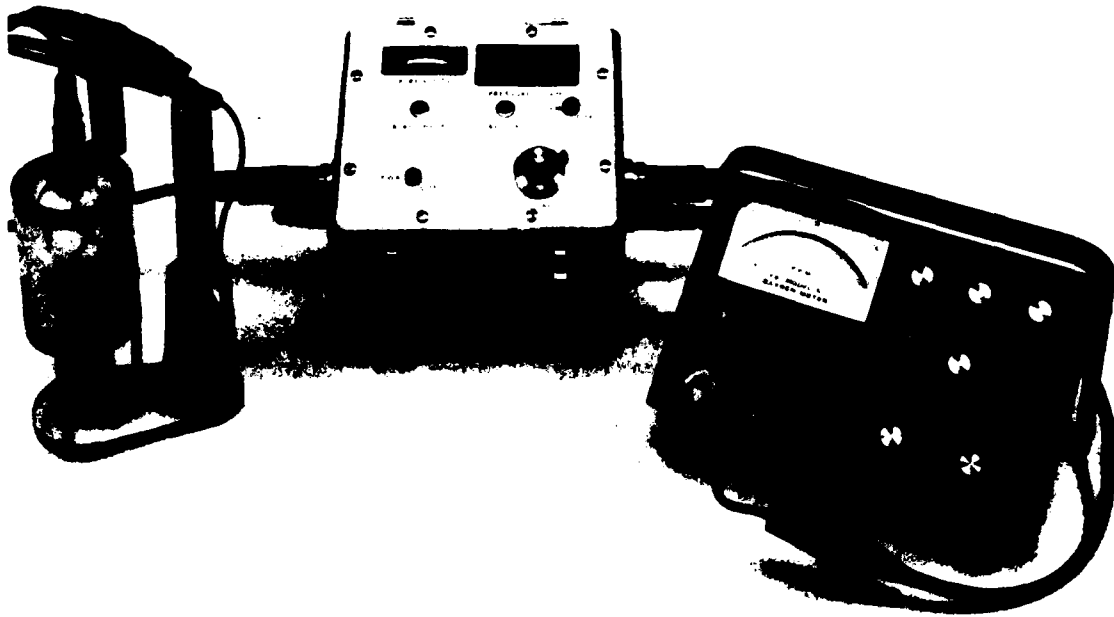

Figure 6. WES saturometer with dissolved oxygen probe

battery charging and unit operation. Printed modular circuit boards are being developed for this unit to facilitate rapid field repair. Cable lengths are designed to provide sufficient flexibility to accommodate depths from 30 ft (9.1 m) to over 300 ft (91.4 m).

26. The WES saturometer measures total dissolved gas pressure plus atmospheric pressure just as the tensionometer does. The unit of measurement is mm Hg. Data analysis is performed with Equation 3, with the measurements representing  $P_{atm} + \Delta P$ . Personnel training to use the WES saturometer is minimal. A very simple pressure transducer calibration check technique is presented in Appendix A.

27. Experience over the past 2 years has shown the WES saturometer to be very reliable. Effects of environmental extremes are minimized with the improved electronics. Integration of the YSI DO/temperature probe into the measurement system greatly simplifies data collection.

### Other Gases

28. Dissolved hydrogen sulfide ( $H_2S$ ), carbon dioxide ( $CO_2$ ), and methane ( $CH_4$ ) occur occasionally in lakes due to decomposition of organic matter. The processes that form these gases usually occur in the lake's hypolimnion. If withdrawal is made through low-level outlets, it is possible to release water containing these gases. Dissolved  $H_2S$ ,  $CO_2$ , and  $CH_4$  contribute very little to total dissolved gas pressure; however, because of water quality, esthetics, or public health concerns, their concentrations may be of interest.

29. Gas chromatographic techniques can be modified with appropriate columns to separate these gases. A thermal conductivity or flame ionization detector may be used in the GC for measuring low-level concentrations. Calibration of the GC for these gases has to be accomplished using prepared standards for each gas. This complicates GC usage compared to the air calibration required for DN and DO. Unless the operator is very competent in GC analysis, these additional complexities significantly increase the chances for operator error.

30. Colorimetric and titrametric (APHA, AWWA, and WPCF 1975; Hach 1976, 1978) techniques are available but were not used in this effort. Manufacturer's literature and water analysis handbooks indicate that these methods are accurate and reliable although time-consuming (similar to iodometric DO titrations).

## PART III: DATA COLLECTION

### Location and Frequency

31. Sampling location and frequency (or timing) are two parameters that must be seriously considered in designing an effective field study program. Foremost in deciding where and when to collect data is the question: What is the purpose of the data? If the purpose of the data is to provide a basis for evaluating the effects of a spillway on dissolved gases, it is imperative that sampling locations be selected to ensure high quality data. As an extreme example, measurements downstream of a powerhouse will indicate little or nothing about releases through the spillway.

32. Sampling locations should be such that other releases have not mixed with the water of interest. Measurements should be made just upstream and downstream of the hydraulic conditions that are being studied, at the center of the mainstream of flow. If at all possible, profiles with depth should be taken, including downstream where mixing and turbulence appear to provide homogeneity.

33. Timing of data collection can be as important as location. For instance, sampling in mid-winter for DO uptake through a structure will reveal very little about oxygen transfer since most free-flowing natural water is near saturation in cold weather. A set interval for field measurements may not supply the data of interest; flow, dissolved gas levels, and other conditions are stochastic in nature and their variations may not coincide with a biweekly measurement frequency. Data from a range of conditions must be collected before reliable conclusions can be drawn about a structure or hydraulic condition.

### Other Data

34. Too often the only data collected are those of immediate interest, i.e., the dissolved gas (DN and DO) concentrations. Other data needed to determine and understand the processes that caused the



measured condition are sometimes forgotten. Collection of the following data will significantly improve the understanding of cause-and-effect relationships:

- a. Geometric details of hydraulic structure.
- b. Observed hydraulic and dissolved gas data.
  - (1) Date.
  - (2) Location of sampling stations.
  - (3) Description of instrumentation.
  - (4) Pool and tailwater elevations.
  - (5) Release water temperature.
  - (6) Release water DO.
  - (7) Release water DN.
  - (8) Barometric pressure.
  - (9) Lake temperature profile.
  - (10) Lake DO profile.
  - (11) Lake DN profile.
  - (12) Number and location of gates opened.
  - (13) Gate openings.
  - (14) Discharge from each gate or outlet.
  - (15) Powerhouse discharge (if applicable).
  - (16) Total discharge.
- c. Photos of flow conditions.

#### PART IV: CONCLUSIONS AND RECOMMENDATIONS

35. The best method for dissolved oxygen determination, based on simplicity, accuracy, and cost, is the polarographic probe technique. Several manufacturers produce these instruments, including Weston and Stack, Leeds and Northrup, and the YSI Company. The YSI probe was used most extensively in field studies that led to this evaluation.

36. The titrametric technique provides excellent accuracy but requires more time for analysis. Since a water sample must be collected, field personnel must be trained in titration techniques as well as proper sample collection and handling and analysis techniques. It is usually costly and time-consuming to chemically analyze the number of samples required to define the oxygen profile of a lake. This technique is recommended for calibrating polarographic probe units and subsequent spot-checking of probe results.

37. For nitrogen determinations, the improved D'Aoust tensionometer or WES saturometer is recommended. These instruments provide a relatively easy method of collecting data for DN determinations. They can measure dissolved gas pressure at depth and equilibrate significantly faster than the Weiss saturometer. Pressure calibration can be checked with the method described in Appendix A.

38. Colorimetric and/or titrametric techniques are recommended for analyses of carbon dioxide and hydrogen sulfide. The accuracy and simplicity of these techniques are apparently adequate to allow easy use under field conditions. As with most chemical analysis techniques, accurate results are predicated on fresh full-strength chemical reagents.

39. The gas chromatograph is not recommended for general field use. It can provide accurate results; however, because of its complexities and the probability for error, if improperly used, it is unsuitable for most field study and data collection programs.

## REFERENCES

- American Public Health Association (APHA), American Water Works Association (AWWA), and Water Pollution Control Federation (WPCF). 1975. Standard Methods for the Examination of Water and Wastewater, 14th ed., APHA, Washington, D. C.
- Bohan, J. P., and Grace, J. L., Jr. 1973. "Selective Withdrawal From Man-Made Lakes," Technical Report H-73-4, U. S. Army Engineer Waterways Experiment Station, CE, Vicksburg, Miss.
- Bouck, G. R. 1980. "Etiology of Gas Bubble Disease," Transactions of the American Fisheries Society, Vol 109, pp 702-707.
- Boyer, P. B. 1974. "Nitrogen Supersaturation and Related Data," U. S. Army Engineer Division, North Pacific, Portland, Oreg.
- Buck, C. L., Miller, D. E., and Sheppard, A. R. 1980. "Prediction of Oxygen Uptake Capabilities in Hydroelectric Turbines Utilizing Draft Tube Aeration Systems," Environmental and Research Services Section, Alabama Power Company, Birmingham, Ala.
- Dawley, E., et al. 1975. "Studies on the Effects of Supersaturation of Dissolved Gases on Fish," National Marine Fisheries Service, Seattle, Wash.
- D'Aoust, B. G., White, R., and Seibold, H. 1976. "An Electronic Monitor for Total Dissolved Gas Pressure," Proceedings of the Workshop on Gas Bubble Disease (Richland, Va., October 1974), pp 106-110.
- D'Aoust, B. G., and Clark, M. J. R. 1980. "Analysis of Supersaturated Air in Natural Waters and Reservoirs," Transactions of the American Fisheries Society, Vol 109, pp 708-724.
- Duscha, L. A. 1980. "Measurement of Dissolved Gases to Determine the Degree of Nitrogen Supersaturation," Engineer Technical Letter No. 1110-2-253, Office, Chief of Engineers, Department of the Army, Washington, D. C.
- Ebel, Wesley J. 1969. "Supersaturation of Nitrogen in Colorado River and Its Effect on Salmon and Steelhead Trout," U. S. Fish and Wildlife Service Fisheries Bulletin, Vol 68, pp 1-11.
- Edmister, T. E., and Smith, P. M. 1976. "Libby Reregulating Nitrogen Study, Nitrogen Reduction with Baffled Chute, Report No. 1," Hydraulics Laboratory, U. S. Army Engineer Division, North Pacific, Portland, Oreg.
- Fickeisen, D. H., Schneider, M. J., and Montgomery, J. C. 1975. "A Comparative Evaluation of the Weiss Saturometer," Transactions of the American Fisheries Society, Vol 104, pp 816-820.
- Hach Chemical Company. 1976. "Water Analysis Handbook," expanded edition, Ames, Iowa.
- \_\_\_\_\_. 1978. "Wastewater Analysis Handbook," Ames, Iowa.

Leggett, D. C. 1979. "Determination of Dissolved Nitrogen and Oxygen in Water by Headspace Gas Chromatography," Special Report 79-24, U. S. Army Engineer Cold Regions Research and Engineering Laboratory, Hanover, N. H.

McNair, H. M., and Bonelli, E. J. 1969. Basic Gas Chromatography, Varian Associates, Inc., Palo Alto, Calif.

Schroeder, E. D. 1977. Water and Wastewater Treatment, McGraw-Hill, New York, N. Y.

Smith, H. A. 1974. "Spillway Redesign Abates Gas Supersaturation in Columbia River," Civil Engineering, Vol 44, No. 1, pp. 70-73, American Society of Civil Engineers.

Thompson, B. 1977. Fundamentals of Gas Analysis by Gas Chromatography, Varian Associates, Inc., Palo Alto, Calif.

Tsivoglou, E. C., and Wallace, J. R. 1972. "Characterization of Stream Reaeration Capacity," EPA-R3-72-012, Environmental Protection Agency, Washington, D. C.

Wilhelms, S. C. 1980. "Tracer Measurement of Reaeration: Application to Hydraulic Models," Technical Report E-80-5, U. S. Army Engineer Waterways Experiment Station, CE, Vicksburg, Miss.

Wilhelms, S. C., and Smith, D. R. 1981. "Reaeration Through Gated Conduit Outlet Works," Technical Report E-81-5, U. S. Army Engineer Waterways Experiment Station, CE, Vicksburg, Miss.

Willis, H. B. 1978. "Nitrogen Supersaturation," Engineer Technical Letter No. 1110-2-239, Office, Chief of Engineers, U. S. Department of the Army, Washington, D. C.

Yellow Springs Instrument Company (YSI). 1975. "Instructions for YSI 5700 Series Dissolved Oxygen Probes," Yellow Springs, Ohio.

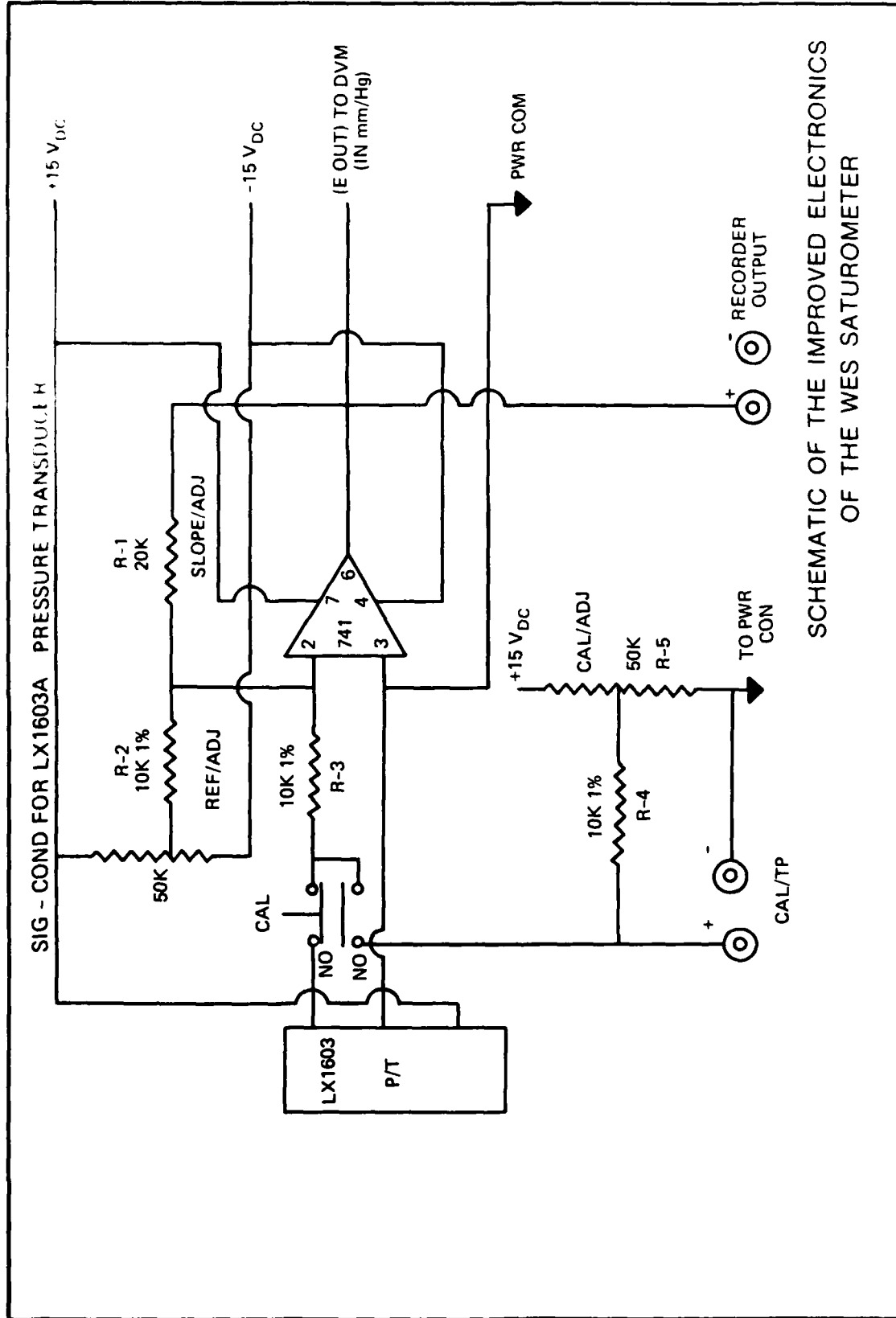

SCHEMATIC OF THE IMPROVED ELECTRONICS  
OF THE WES SATUROMETER

APPENDIX A: FIELD CALIBRATION OF ELECTRONIC D'AOUST  
TENSIONOMETER OR WES SATUROMETER\*

1. The purpose of this appendix is to provide information on a technique for quick and accurate calibration or check of a tensionometer or WES saturometer under field conditions. Ambient temperature changes and other environmental effects can sometimes affect electronics and cause readings to drift, resulting in inaccurate measurements of total dissolved gas pressure. A quick and accurate technique to check and/or calibrate these instruments under field conditions is required to ensure that measurements of dissolved gas pressure are as accurate as possible.

2. This technique uses a syringe attached to the pressure transducer to create pressures above and below atmospheric pressure. Laboratory experiments indicated that plunging or withdrawing the syringe plunger to increase or decrease pressure could be considered as a reversible isothermal process. In both cases, the heat transfer processes are rapid with respect to the time required to execute the calibration procedure. Thus, the compression or expansion process can be mathematically described by Boyle's Law

$$P_1 V_1 = P_2 V_2 \quad (A1)$$

where

$P_1$  = pressure of gas at a volume of  $V_1$

$P_2$  = pressure of gas at a volume of  $V_2$

Use of Equation A1 is illustrated in the calibration example.

3. The equipment required is:

1 20-ml gas-tight syringe and 25-ga needle

1 3-cm-long piece Silastic tubing

1 barometer

2 screwdrivers, assorted sizes

---

\* Some steps apply only to original design D'Aoust tensionometers.

Items are available through scientific, chemical, and medical supply companies.

4. The following precautions must be exercised during calibration:
  - a. Avoid extreme temperature changes in the air in the syringe. All calibration equipment must be at the surrounding temperature.
  - b. Do not move from a cold to a warm environment or from a warm to a cold environment during calibration.
  - c. Exercise care in handling the syringe since body heat could raise the syringe temperature.
5. The following procedures are to be followed:
  - a. Allow instrument to warm up for 15 to 20 min. Use this time to remove the permeable tubing (curler).
  - b. Set the syringe on the 10-ml line for a 20-ml syringe or the 25-ml line for a 50-ml syringe and make the connection as shown in Figure A1.

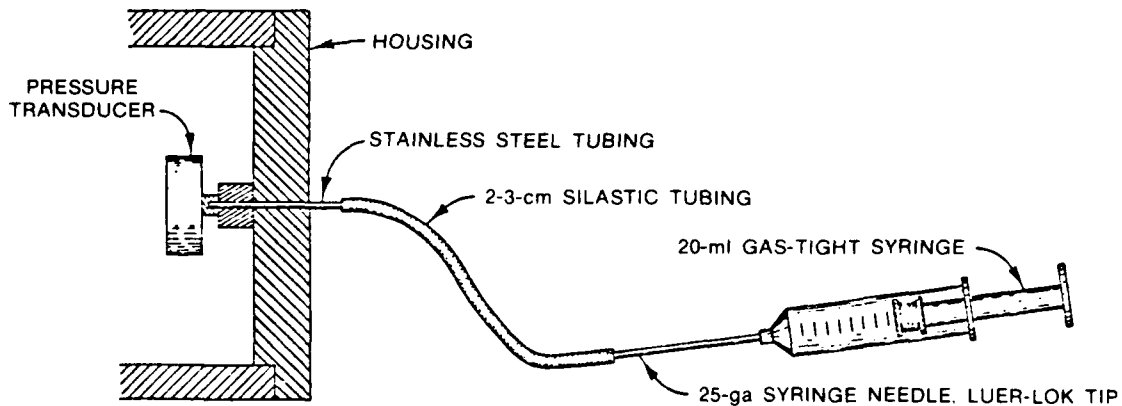

Figure A1. Syringe and pressure transducer setup for calibration

- c. Set the syringe to a new volume and use Boyle's Law (Equation A1) to compute the pressure readings.

**EXAMPLE:**

Determine atmospheric pressure (assume 750 mm Hg, for example). Disassemble sensor, make syringe (20-ml) setup, and allow instrument to warm up.

For Zero Adjustment:

Withdraw plunger to 12-ml line

Pressure reading should be:

$$P_2 = \frac{P_1(V_1)}{V_2} = 750 \frac{10}{12} = 625 \text{ mm Hg}$$

Adjust zero potentiometer to produce computed reading (625 mm Hg, in this case). If reading drifts toward atmospheric pressure, connections should be checked for leaks.

For Span Adjustment:

Plunge syringe to 8-ml line

Pressure reading should be:

$$P_2 = \frac{P_1(V_1)}{V_2} = 750 \frac{10}{8} = 938 \text{ mm Hg}$$

Adjust span potentiometer to produce computed reading (938 mm Hg, in this case). If reading drifts toward atmospheric pressure, connections should be checked for leaks. Repeat the zero and span calibrations 2 to 3 times to converge on calibration settings. Atmospheric pressure should be displayed on the readout when the calibration equipment is removed.

For technical assistance contact:

U. S. Army Engineer Waterways Experiment Station  
Reservoir Water Quality (Physical) Branch (WESHS-R)  
Hydraulics Laboratory  
P. O. Box 631  
Vicksburg, Miss. 39180



FILMED

8