

AD-A142 567

TECHNICAL SUPPORT FOR MICROWAVE EXPERIMENTS ON THE EYE
LENS: INTERFEROMET... (U) SCIENCE APPLICATIONS INC MCLEAN
VA ELECTRO-OPTICS TECHNOLOGY D... N C WYETH OCT 81

1/1

UNCLASSIFIED

SAI-168-030-025 DAMD17-80-C-0057

F/G 6/18

NL



END
DATE
FILMED
8-84
DTIC

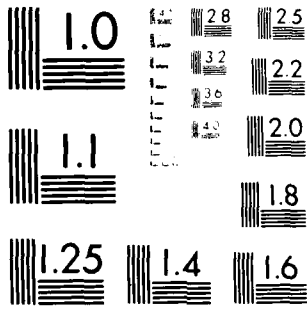

MICROCOPY RESOLUTION TEST CHART
NBS 1963-A

AD _____

(1)

(Report Number)

TECHNICAL SUPPORT FOR

MICROWAVE EXPERIMENTS ON THE EYE LENS

SUBTITLE:

INTERFEROMETRIC MEASUREMENT OF EYE LENS

MOTION UNDER MICROWAVE PULSE EXPOSURE

Annual Report for Period
March 1, 1980 to August 31, 1981

N. Convers Wyeth
October 1981

Supported by
U.S. ARMY MEDICAL RESEARCH AND DEVELOPMENT COMMAND
Fort Detrick, Frederick, Maryland 21701

Contract No. DAMD17-80-C-0057

Science Applications, Inc.
McLean, Virginia 22102

DTIC
ELECTRONIC
JUN 29 1984
A

AD-A142 567
DTIC FILE COPY

Approved for public release; distribution unlimited.

The findings in this report are not to be construed as an official
Department of the Army position unless so designated by other
authorized documents.

84 06 28 105

Unclassified

SECURITY CLASSIFICATION OF THIS PAGE (When Data Entered)

REPORT DOCUMENTATION PAGE		READ INSTRUCTIONS BEFORE COMPLETING FORM
1. REPORT NUMBER	2. GOVT ACCESSION NO. A 142 567	3. RECIPIENT'S CATALOG NUMBER
4. TITLE (and Subtitle) Technical Support for Microwave Experiments on the Eye Lens - Subtitle: Interferometric Measurement of Eye Lens Motion Under Microwave Pulse Exposure		5. TYPE OF REPORT & PERIOD COVERED Annual Report March 1, 1980 to August 31, 1981
		6. PERFORMING ORG. REPORT NUMBER 168-030-025
7. AUTHOR(s) N. Convers Wyeth		8. CONTRACT OR GRANT NUMBER(s) DAMD17-80-C-0057
9. PERFORMING ORGANIZATION NAME AND ADDRESS Electro-Optics Technology Division Science Applications, Inc. 1710 Goodridge Dr., McLean, Virginia 22102		10. PROGRAM ELEMENT, PROJECT, TASK AREA & WORK UNIT NUMBERS 62771A.3E162771A805.00.015
11. CONTROLLING OFFICE NAME AND ADDRESS U.S. Army Medical Research and Development Command Fort Detrick, Frederick, Maryland 21701		12. REPORT DATE October 1981
		13. NUMBER OF PAGES 9
14. MONITORING AGENCY NAME & ADDRESS (if different from Controlling Office)		15. SECURITY CLASS. (of this report) Unclassified
		15a. DECLASSIFICATION/DOWNGRADING SCHEDULE
16. DISTRIBUTION STATEMENT (of this Report) Approved for public release; distribution unlimited.		
17. DISTRIBUTION STATEMENT (of the abstract entered in Block 20, if different from Report)		
18. SUPPLEMENTARY NOTES		
19. KEY WORDS (Continue on reverse side if necessary and identify by block number) Laser interferometry Microwave cataractogenesis		
20. ABSTRACT (Continue on reverse side if necessary and identify by block number) A research program at Walter Reed Army Institute of Research (WRAIR) is concerned with the mechanism by which microwave exposure produces cataracts in the eye lens. Science Applications, Inc. (SAI) is supporting WRAIR personnel in system design, equipment assembly, and operation of experiments to measure the physical effects in the eye lens as it is subjected to microwave pulses of varying peak power levels. This report describes an ongoing project using a laser interferometer and rat eye lens in vitro. The experiment is presently in the data collection phase, with no firm conclusions yet drawn.		

DD FORM 1473 1 JAN 73 EDITION OF 1 NOV 65 IS OBSOLETE

Unclassified
SECURITY CLASSIFICATION OF THIS PAGE (When Data Entered)

SUMMARY

A research program at Walter Reed Army Institute of Research (WRAIR) is concerned with the mechanism by which microwave exposure produces cataracts in the eye lens. Science Applications, Inc. (SAI) is supporting WRAIR personnel in system design, equipment assembly, and operation of experiments to measure the physical effects in the eye lens as it is subjected to microwave pulses of varying peak power levels. This report describes an ongoing project using a laser interferometer and rat eye lens in vitro. The experiment is presently in the data collection phase, with no firm conclusions yet drawn. .

A1

1. Introduction and Background

The causal relationship between excessive microwave exposure and the subsequent development of cataracts in the eye lens is well documented. Present safety standards are specified in terms of maximum average power level and duration of exposure. There remains the question of whether the peak power occurring within a given average power exposure has any additional effect on cataract production; if it does, the safety standards should be rewritten to take account of this. The physical mechanism by which the radiation triggers subsequent cataract formation is also not well defined.

A research program at the Walter Reed Army Institute of Research (WRAIR) is addressing these issues and using optical techniques to measure the physical effects in the eye lens as it is subjected to microwave pulses of varying peak power levels. Science Applications, Inc. (SAI) has supported WRAIR personnel in system design, equipment assembly, and operation of an experiment to detect physical deformation of an eye lens induced by microwave pulses using laser interferometric techniques. This experiment is presently in the data collection phase, with no firm conclusions yet drawn.

2. Initial System Design and Operation

After a review of the mechanisms available to couple the energy of a microwave pulse into a physical deformation of the eye lens, it was decided that thermo-acoustic (TA) waves involving a natural resonance frequency of the lens might provide such a coupling. As deformations the order of a micron or less were expected, optical interferometry was chosen as the initial measurement technique.

A simple Michaelson interferometer was designed with an expanded beam from a small He-Ne laser as the light source. The beam was split and recombined using a pellicle beam splitter to avoid second surface reflection problems. A convex lens was placed in the object beam to focus the collimated laser beam to a small spot on the surface of the eye lens. In theory any small area of the eye lens will be approximately a section of a sphere, and through proper alignment the converging wave fronts from the object beam focusing lens can be made to reflect congruently from this surface and return through the lens to the beam splitter with good light collection efficiency.

An interference pattern with light and dark fringes results when the reference and object beams are recombined. This fringe pattern is determined by the contours of the part of the eye lens surface on which the laser beam is focused and will move as that surface is displaced. A small aperture silicon photodetector was placed in the interference pattern, and the fringe width adjusted using the reference mirror so that it was comparable to the detector size. A fast amplifier system connected to the detector allowed the readout on an oscilloscope or a signal averager of the changes in output caused by motion of light and dark fringes across the aperture.

The eye lens is immersed in a liquid medium during the experiment; this approximates its situation in vivo and is used in the other microwave exposure work at WRAIR. With a saline medium, the reflected signal from the eye lens/liquid interface was expected to be on the order of 0.1%. Thus the reference beam intensity had to be similarly attenuated for good fringe visibility in the interference pattern, so a flat glass plate with antireflection coating was used for the reference beam mirror.

The entire interferometer was mounted on an air-supported isolation table. A sample holder was constructed of plexiglas with the eye lens held between two vertical rods in a small (~ 10 ml) liquid-filled reservoir. The focused laser beam entered through an optically flat glass window which was mounted at a slight tilt to remove surface reflections from the signal path. Ray-tracing calculations had shown that in a well aligned system, such a window would not significantly perturb the interference pattern. The section of the rear wall of the reservoir chamber directly behind the eye lens was tilted back to reflect light transmitted through the lens out of the return beam direction. The sample holder extended from the edge of the isolation table into the microwave waveguide through a small opening in the sidewall of the latter. The waveguide itself was not connected to the table so that the sample holder and optical system were isolated from any mechanical motion associated with the microwave pulse.

The operation of the optical system was tested in a progression of configurations leading toward the desired arrangement. Interference fringes were obtained with the laser beam reflected from a small glass sphere (approximating the rat eye lens) both without and with the optically flat window in the beam. The fringe patterns obtained in these and all subsequent configurations were somewhat irregular but had contrast ratios and fringe widths which are easily adequate for the purposes of this experiment. Good fringes were also achieved with the glass sphere in a water-filled reservoir. With this foundation established, actual rat eye lenses were tried next. A fringe pattern was obtainable for the eye lens in air but only with great difficulty when immersed in water (saline solution). Calculations indicated that this was due to the low index mismatch and consequent low reflectivity at the water/lens interface. A high index mineral

oil ($n = 1.57$) was used for the immersion medium and a good fringe pattern was achieved. However the microwave dielectric properties of the oil were unknown and attempts to couple the pulse power to the oil-filled reservoir were unsuccessful. Moreover, the effects of the oil on the eye lens are unknown, and its use would remove the experiment further from the *in vivo* situation and from the other microwave exposure experiments.

In general, the interference pattern showed too much noise in the form of pattern motion and intensity fluctuation for proper operation in a measurement of very small displacements.

3. System Modifications

As a result of the initial testing of the system, several refinements in the original design were implemented. The pellicle membrane was replaced by a glass-wedge beamsplitter as the acoustic noise from the former was unacceptable in this application. Another source of noise was the laser. The noise level in the output intensity was successfully reduced by repairs in the power supply, improvements in the laser tube cooling, and the addition of a beam intensity monitor detector whose output can be used to normalize the effect of residual intensity fluctuations on the fringe-motion detector signal if needed.

The glass plate reference mirror was replaced with a silvered mirror ($> 90\%$ reflectivity) which increased the modulation amplitude of the fringe signal by about a factor of five. A rotatable half-wave plate and a pair of polarizers were inserted into the reference beam to allow adjustment of the intensity without loss of phase coherence. With this arrangement the reference beam intensity can be turned down for maximum fringe visibility while tuning in the

interference pattern from the eye lens, then turned up for maximum modulation while looking at fringe motion with an ac coupled detector.

The new reference mirror was mounted on a calibrated piezoelectric transducer. This device moves the mirror along the normal to its surface by a precise (1%) amount for a given input voltage; the movement is approximately 1.8 nm per volt. Thus a signal of known frequency and amplitude can be imposed on the interference fringe pattern. This is useful in positioning the photodetector within the pattern at the location most sensitive to fringe motion.

By operating the piezoelectric transducer at a frequency which is incommensurate with the microwave pulse rate, it can be used during an actual data run to give a real-time indication of system performance and calibration. The signal averager used to process the data is triggered from the microwave pulse generator and simply averages the uncorrelated reference signal to zero.

Other improvements included shielding all of the laser beam paths from air currents and their attendant temperature variations and enlarging the volume of the liquid reservoir to allow better coupling of the microwave pulse to the absorbing medium. A schematic of the system is shown in Figure 1.

4. Experimental Results to Date

With a glass container of saline solution as the object, the system has detected motion induced by a microwave pulse, presumably through thermo-acoustic (TA) expansion. The signal was accompanied by the characteristic audible TA click and vanished when the microwave power was reduced enough to stop producing the clicks.

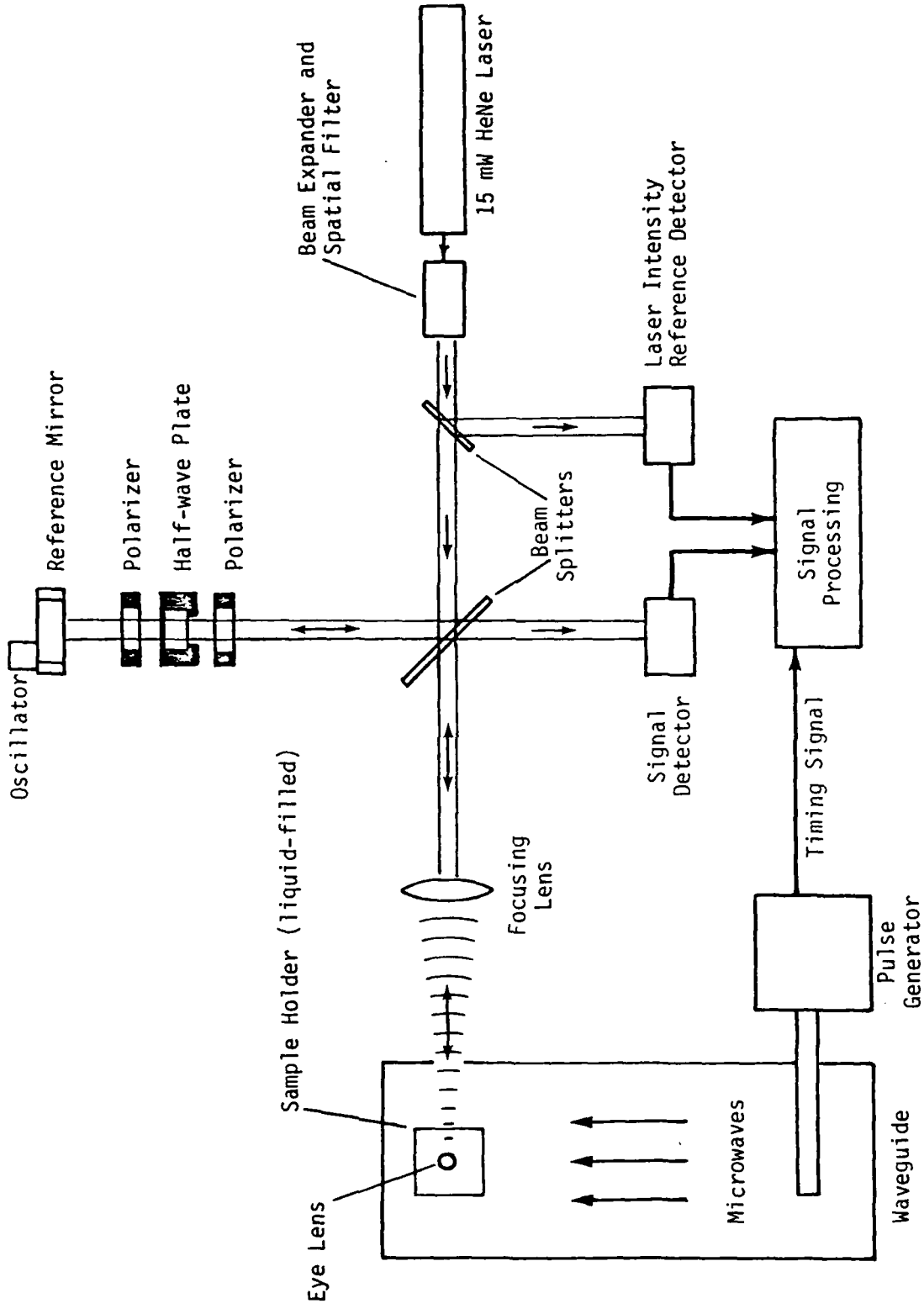

Figure 1. Schematic Diagram of Experimental System.

Next, tests were run using one of the small glass spheres in the eye lens holder within the enlarged saline reservoir. With the waveguide tuned for maximum absorption in the saline solution, the optical system detected a movement of the "glass eye lens" of about 15 nm for a 20 μ sec pulse with a 60 kW peak power. A series of tests were run to show that this signal was originating in the sample holder and was not produced by mechanical or noise vibrations coming from elsewhere in the system. An acoustic barrier was placed in the waveguide to attenuate any sounds coming from the transition or tuning screws. The delays in the signal filtering electronics were measured and it was established that the detected movement coincided with the arrival of the microwave pulse at the sample holder. Any pickup of acoustic disturbances would involve delays on the order of a millisecond or more and as such was easily discounted. The characteristic TA clicks were again audible in this arrangement.

5. Experiments to Follow

With the optical system now operating well and good coupling of the microwaves to the sample holder achieved, the next experiments will involve actual eye lens from rats. Initially the normal reflection mode as embodied in the present system design will be tried. If difficulties arise, alternate optical configurations will be explored.

Since the tests with the glass eye lens showed motion, it should be determined whether this motion, which must originate in the saline, is transmitted to the lens through waves in the liquid (as could also occur in vivo) or through the supporting pedestals (experimental artifact).

**ATE
LME**