

#1217886

AMMRC TR 83-27
(Revised)

AD

AD-A142 258

SPLIT HEAT MECHANICAL PROPERTY COMPARISON OF ESR AND VAR 4340 STEEL

CHARLES F. HICKEY, Jr. and ALBERT A. ANCTIL
METALS RESEARCH DIVISION

May 1983

Approved for public release; distribution unlimited.

DTIC
JUN 20 1984

ARMY MATERIALS AND MECHANICS RESEARCH CENTER
Watertown, Massachusetts 02172

DA 08 10 004

The findings in this report are not to be construed as an official Department of the Army position, unless so designated by other authorized documents.

Mention of any trade names or manufacturers in this report shall not be construed as advertising nor as an official indorsement or approval of such products or companies by the United States Government.

DISPOSITION INSTRUCTIONS

Destroy this report when it is no longer needed.
Do not return it to the originator.

UNCLASSIFIED

SECURITY CLASSIFICATION OF THIS PAGE (When Data Entered)

REPORT DOCUMENTATION PAGE		READ INSTRUCTIONS BEFORE COMPLETING FORM
1. REPORT NUMBER AMMRC TR 83-27 (Revised)	2. GOVT ACCESSION NO.	3. RECIPIENT'S CATALOG NUMBER
4. TITLE (and Subtitle) SPLIT HEAT MECHANICAL PROPERTY COMPARISON OF ESR AND VAR 4340 STEEL		5. TYPE OF REPORT & PERIOD COVERED Final Report
7. AUTHOR(s) Charles F. Hickey, Jr. and Albert A. Anctil		6. PERFORMING ORG. REPORT NUMBER
9. PERFORMING ORGANIZATION NAME AND ADDRESS Army Materials and Mechanics Research Center Watertown, Massachusetts 02172 DRXMR-MM		8. CONTRACT OR GRANT NUMBER(s)
11. CONTROLLING OFFICE NAME AND ADDRESS U. S. Army Materiel Development and Readiness Command, Alexandria, Virginia 22333		10. PROGRAM ELEMENT, PROJECT, TASK AREA & WORK UNIT NUMBERS D/A Project: 1L162105AH84 AMCMS Code: 612105.H840011 Agency Accession: DA OG9371
14. MONITORING AGENCY NAME & ADDRESS (if different from Controlling Office)		12. REPORT DATE May 1983
		13. NUMBER OF PAGES 19
		15. SECURITY CLASS. (of this report) Unclassified
		15a. DECLASSIFICATION/DOWNGRADING SCHEDULE
16. DISTRIBUTION STATEMENT (of this Report) Approved for public release; distribution unlimited.		
17. DISTRIBUTION STATEMENT (of the abstract entered in Block 20, if different from Report)		
18. SUPPLEMENTARY NOTES Revised to include English as well as Metric Measurements.		
19. KEY WORDS (Continue on reverse side if necessary and identify by block number) Low alloy steels Mechanical properties Tempering Electroslag remelting Toughness Vacuum arc remelting Microstructure		
20. ABSTRACT (Continue on reverse side if necessary and identify by block number) <p>(SEE REVERSE SIDE)</p>		

Block No. 20

ABSTRACT

This report addresses a mechanical property characterization of a split argon-oxygen decarburized (AOD) heat of 4340 steel which was further processed by vacuum arc remelting (VAR) and electroslag remelting (ESR) into 12.7 cm (5 inch) square forgings. Properties examined were hardness, tensile, Charpy V-notch impact, and fracture toughness as a function of tempering temperature over the range of 163°C (325°F) to 649°C (1200°F) for both the longitudinal and transverse orientations. Microstructural aspects are also addressed.

Results indicate nearly identical tensile properties for the ESR and VAR processed material. These properties exceed the required specification in the HRC 54-57 range. Ductility measurements were anisotropic for both remelting techniques. Charpy impact values were consistently higher for VAR material over the 260°C (500°F) to 649°C (1200°F) tempering range. A significant amount of scatter in impact data was observed at tempers from 163°C (325°F) to 204°C (400°F). Fracture toughness, K_Q , was higher for VAR material in both the LT and TL orientations for tempering temperatures up to 427°C (800°F). The lower values observed in the ESR heat examined are attributed to calcium aluminate inclusions which can be introduced by electroslag remelting.

CONTENTS

	Page
INTRODUCTION.	1
MATERIAL AND TESTING PROCEDURE.	2
RESULTS AND DISCUSSION	
Mechanical Properties.	3
Tensile Properties	3
Impact Energy.	4
Fracture Toughness	5
Microstructure	5
CONCLUSIONS	6
ACKNOWLEDGMENT.	6

INTRODUCTION

Enhancing aircraft survivability is currently an area of great interest. There are a number of factors which relate to extended life. One factor of prime importance is the development and utilization of materials which increase the damage tolerance characteristics when used for either integral structural or component applications. Research and development efforts have addressed this from a materials aspect by considering composites, metal laminates, and metals in the monolithic form. Of major interest in this area to the Army Materials and Mechanics Research Center in recent years has been the development and characterization of specially processed steels for aircraft application where ballistic tolerance is important.

The first major aircraft application of electroslag remelted (ESR) steel to improve survivability is in the Army's Advanced Attack Helicopter (AAH) Program. Electroslag remelted 4340 steel is used parasitically as driveshaft and hydraulic heat exchanger deflector armor. As integral armor, ESR steel is machined into ballistically survivable hydraulic actuators, rotor pitch links, bearing sleeves, crank assemblies, and scissors. (*,1) Recently, ESR 4350 steel was chosen for the Blackhawk utility helicopter crew seat. (2) The primary reason for selecting ESR steel is based upon its superior ballistic properties attributed primarily to the improved shatter resistance accompanying a low sulfide inclusion content. (1-3) Lower estimated cost was also a significant factor; however, the present demand has not been sufficient enough to make electroslag remelting cost effective.

Electroslag remelting competes with vacuum arc remelting (VAR) and therefore its performance in terms of mechanical and ballistic properties are compared. There has been a great deal of heat to heat variability in electroslag remelted ingots. For example, a recent study has shown that nine commercial heats of ESR 4340 steel purchased from three major producers did not meet required material property specifications at high hardness levels (HRC 55). (4) Short transverse mechanical properties revealed a severe loss of ductility due to grain boundary segregation of phosphorus and sulfur during solidification and later when austenitizing. (4) A homogenization treatment was found to be essential at these extreme hardness levels.

The same embrittlement mechanism found in ESR steel was also detected in air-melted armor and vacuum induction melted 4340 steel. It was impossible to make meaningful comparisons between the various remelting procedures due to the unusually high hardness level and lack of short transverse property data. Improper comparisons have been made from heats of steel with dissimilar chemical compositions and having vastly different processing histories.

This fact precipitated the need for a characterization study involving a split-heat comparison of electroslag and vacuum arc remelting processes. The phase of the split-heat comparison program which addressed the relative hydrogen embrittlement

*McDERMOTT, J. M., and VEGA, E. *The Effects of Latest Military Criteria on the Structural Weight of the Hughes Advanced Helicopter*. Hughes Helicopters, Culver City, CA, Unpublished Work, 1977.

1. ROHTERT, R. E. *Ballistic Design Support Tests - A Tool for Helicopter Vulnerability Reduction*. Presented at the AHS 31st Annual National Forum, Preprint No. 984, May 1975.
2. PRITFI, J. J., PAPETTI, D., and RICCI, W. *ESR Steel/Kevlar Armored Bucket Seat for Aircrew Protection*. Army Materials and Mechanics Research Center, Published in JTCG/AS Conference on Design of Armor Systems Proceedings, June 1983 (Confidential Report).
3. HICKEY, C. F., Jr., ANCTIL, A. A., and CHAIT, R. *The Ballistic Performance of High Strength 4340 Steel Processed by Electroslag Remelting*. Proceedings on Fracture Toughness of Wrought and Cast Steels, E. Fortner, ed., ASME MPC-13, 1980, p. 219-229.
4. OLSON, G. B., ANCTIL, A. A., DeSISTO, T. S., and KULA, E. B. *Anisotropic Embrittlement in High-Hardness ESR 4340 Steel Forgings*. Army Materials and Mechanics Research Center, AMMRC TR 82-1, January 1982.

susceptibility and heat treatment distortion properties has been completed. The results indicated that the VAR material is less susceptible to hydrogen embrittlement and that essentially no difference exists in distortion propensity.(5) The last phase will compare the effect of strain rate and humidity on engineering properties and evaluate ballistic performance. This paper compares the mechanical properties and metallurgical differences.

MATERIAL AND TESTING PROCEDURE

The material studied in this investigation was a split argon-oxygen decarburized (AOD) heat of 4340 steel which was further processed by VAR and ESR into 12.7-cm (5 inch) square forgings. The chemical composition for the AOD, VAR, and ESR conditions is shown in Table 1. It should be noted that the AOD heat was of such high purity (0.001 wt% S) that it minimized the benefit of sulfur reduction that is achieved through ESR processing. The decreased manganese content during VAR processing was expected and was due to the high vapor pressure of this element. Photomicrographs of the VAR and ESR forgings are shown in Figure 1.

Hardness, tensile, standard Charpy impact and fracture toughness data were obtained as a function of tempering temperature and specimen orientation. Specimens were machined to blank form and then normalized at 899°C (1650°F) for 1 hour and air cooled, austenitized at 843°C (1550°F) for 1 hour and oil quenched, and then tempered. Tempering temperatures of 163°C (325°F), 171°C (340°F), 260°C (500°F), 316°C (600°F), 427°C (800°F), 538°C (1000°F), and 649°C (1200°F) for 1 hour were selected for this study. The tempered martensitic microstructures that resulted from each of these tempering temperatures are shown in Figure 2 and 3 (a-h).

Table 1. CHEMICAL COMPOSITIONS

RE MELTING PROCESS	Weight Percent									
	C	Mn	Si	Ni	Cr	Mo	P	S	Cu	Al
AOD	0.42	0.66	0.24	1.73	0.94	0.22	0.007	0.001	0.19	0.032
VAR	0.42	0.46	0.28	1.74	0.89	0.21	0.009	0.001	0.19	0.031
ESR	0.41	0.70	0.26	1.73	0.90	0.22	0.008	0.001	0.21	0.035

Tension tests were conducted on standard 6.4-mm (0.252 inch) diameter specimens with a 31.75-mm (1.25 inch) reduced section and a 25.4-mm (1.0 inch) gage length at a crosshead speed of 0.127-mm/min (0.005 inch/min). Standard 10-mm (0.394 inch) cross section Charpy V-notch specimens were used in obtaining impact data. Pre-cracked Charpy type specimens were used in obtaining the fracture toughness data (K_Q). K_Q is a conditional plane strain (K_{Ic}) value and is obtained from the load-deflection curves for each specimen using the conventional stress intensity factor calculations for 3-point bending. Definition of the crack plane orientation for the impact and fracture toughness specimens is shown in Figure 4. A limited amount of scanning electron microscopy (SEM) work was also conducted.

5. RAYMOND, L., and BENEKER, C. *Evaluation of the Relative Hydrogen Embrittlement Susceptibility of ESR 4340 and Its Heat Treatment Distortion Properties*. Parker Hannifin Corporation, Contract DAAG46-81-C-0045, Final Report, AMMRC TR 82-49, September 1982.

RESULTS AND DISCUSSION

Mechanical Properties

Hardness

Rockwell C hardness (HRC) is plotted as a function of tempering temperature in Figure 5. There are no significant differences between the VAR and ESR processed material over the investigated tempering range. Values decrease as a function of increasing tempering temperature from approximately HRC 57 at 163°C (325°F) to HRC 31 at 649°C (1200°F). It should be noted that the hardness level following the 163°C (325°F) and 171°C (340°F) tempers conforms to requirements set forth by Hughes Helicopters process specification HM56-1121 (HRC 54-57) for their applications and components. This specification calls for the following minimum mechanical properties for both the longitudinal and transverse orientations: 1379 MPa (200 ksi), 0.2% yield strength; 1931 MPa (280 ksi), ultimate tensile strength (54-57 HRC); 10% elongation; and 25% reduction of area.

Tensile Properties

Tensile data for the materials are shown in Table 2. To illustrate the differences which exist between the VAR and ESR processed material and the effect of specimen orientation, the strength data are plotted in Figure 6 and the ductility values are shown in Figure 7. As evident in Figure 6 there are no significant differences in yield or ultimate tensile strength, either as a function of processing or specimen orientation. There is an indication of a slight decrease in yield strength between the 171°C (340°F) and 163°C (325°C) temper. Previous work by the authors on another heat of ESR 4340 showed a similar trend between the 177°C (350°F) and 163°C (325°F) temper.(3)

Table 2. EFFECT OF TEMPERING TEMPERATURE AND ORIENTATION ON THE TENSILE PROPERTIES OF VAR AND ESR 4340 STEEL

PROCESS		VAR				ESR			
Orientation	Temper °C (°F)	0.2%YS MPA (KSI)	UTS MPA (KSI)	ELON %	RA %	0.2%YS MPA (KSI)	UTS MPA (KSI)	ELON %	RA %
LONG.	163 (325)	1594.0 (231.2)	2164.3 (313.9)	12.3	43.3	1605.8 (232.9)	2165.0 (314.0)	12.2	45.2
	171 (340)	1612.7 (233.9)	2149.8 (311.8)	13.2	45.0	1620.3 (235.0)	2149.1 (311.7)	13.0	48.5
	204 (400)	1618.9 (234.8)	2002.3 (290.4)	13.7	45.8	1605.1 (232.8)	1989.8 (288.6)	12.8	49.9
	260 (500)	1563.1 (226.7)	1849.9 (268.3)	12.4	51.5	1567.2 (227.3)	1860.2 (269.8)	12.4	51.2
	316 (600)	1496.2 (217.0)	1758.2 (255.0)	12.8	52.6	1501.0 (217.7)	1739.6 (252.3)	13.2	54.2
	427 (800)	1341.7 (194.6)	1466.5 (212.7)	12.2	48.5	1367.9 (198.4)	1485.1 (215.4)	13.4	52.3
	538 (1000)	1092.8 (158.5)	1196.9 (173.6)	16.5	57.7	1136.9 (164.9)	1227.3 (178.0)	16.3	57.3
	649 (1200)	826.7 (119.9)	966.7 (140.2)	22.6	66.9	852.9 (123.7)	968.7 (140.5)	22.1	63.9
TRANS.	171 (340)	1599.6 (232.0)	2151.9 (312.1)	12.3	39.8	1623.0 (235.4)	2146.4 (311.3)	11.4	37.4
	204 (400)	1603.0 (232.5)	2003.6 (290.6)	11.0	41.3	1594.1 (231.2)	1990.5 (288.7)	11.4	38.2
	260 (500)	1567.9 (227.4)	1855.4 (269.1)	11.9	44.4	1569.9 (227.7)	1845.1 (267.6)	11.0	42.7
	316 (600)	1507.2 (218.6)	1741.6 (252.6)	11.6	45.8	1487.2 (215.7)	1712.7 (248.4)	13.0	47.9
	427 (800)	1352.1 (196.1)	1476.2 (214.1)	12.7	48.1	1356.9 (196.8*)	1474.8 (213.9*)	11.6*	43.1*
	538 (1000)	1106.6 (160.5)	1210.0 (175.5)	16.1	56.5	1117.7 (162.1)	1206.6 (175.0)	15.5	51.2
	649 (1200)	843.9 (122.4)	978.4 (141.9)	22.7	66.3	852.9 (123.7)	967.3 (140.3)	21.7	63.5

*Single test, remainder are average of two tests.

Figure 7 contains a plot showing the effect of tempering temperature on the ductility properties as a function of process type and orientation. Reduction-of-area data show several interesting trends. Longitudinal values are equal or superior for the ESR material for all tempering temperatures up to 538°C (1000°F). Transverse data show the opposite trend with the VAR material being superior at all temperatures except 316°C (600°F). Another significant finding is the large amount of anisotropy which exists for both processed materials for tempering temperatures through 316°C (600°F) and up to 538°C (1000°F) for the ESR material. The VAR data are slightly higher than the ESR for both orientations at the 649°C (1200°F) temper. There is little variation in elongation values for each process with a dependence upon specimen orientation.

Impact Energy

Charpy impact energy data are plotted as a function of orientation and tempering temperature in Figure 8. An enlarged scale of the 163°C (325°F) to 260°C (500°F) temper range is also plotted in Figure 8, and the data for this range is shown in Table 3.

Table 3. EFFECT OF TEMPERING TEMPERATURE AND ORIENTATION ON THE CHARPY IMPACT ENERGY OF VAR AND ESR 4340 STEEL

TEMPER, °C (°F)	ENERGY, JOULE (FT-LB)			
	LONGITUDINAL (LT)		TRANSVERSE (TL)	
	VAR	ESR	VAR	ESR
163 (325)	25.5 (18.8)	25.5 (18.8)	25.5 (18.8)	25.8 (19.0)
			21.7 (16.0)	18.4 (13.6)
			<u>17.6 (13.0)</u>	<u>19.0 (14.0)</u>
			21.6 (15.9)	21.0 (15.5)
171 (340)	22.9 (16.9)	23.5 (17.3)	27.0 (19.9)	22.4 (16.5)
	<u>24.4 (18.0)</u>	<u>24.3 (17.9)</u>	21.4 (15.8)	<u>21.4 (15.8)</u>
	23.7 (17.5)	23.9 (17.6)	<u>22.6 (16.7)</u>	22.0 (16.2)
			23.7 (17.5)	
204 (400)	27.0 (19.9)	25.8 (19.0)	20.6 (15.2)	24.7 (18.2)
	<u>27.0 (19.9)</u>		24.7 (18.2)	<u>24.1 (17.8)</u>
	27.0 (19.9)		<u>21.4 (15.8)</u>	24.4 (18.0)
			22.2 (16.4)	
260 (500)	20.2 (14.9)	18.8 (13.9)	21.0 (15.5)	19.4 (14.3)
	<u>20.1 (14.8)</u>	<u>20.3 (15.0)</u>	<u>21.0 (15.5)</u>	<u>20.1 (14.8)</u>
	20.2 (14.9)	19.7 (14.5)	21.0 (15.5)	19.8 (14.6)

At tempering temperatures of 260°C (500°F) and above there is a consistent trend of the energy values being slightly higher for the VAR than ESR processed material for both the LT and TL orientation. Except for the 649°C (1200°F) temper there is little evidence of anisotropy or data scatter.

Since high hardness is a major criterion in the utilization of materials for armor and many helicopter applications, the energy values obtained from the

163°C (325°F) to 260°C (500°F) tempers are of prime interest. The expanded plot in Figure 8 indicates that there is a large degree of scatter in the data for tempers of 163°C (325°F), 171°C (340°F), and 204°C (400°F). The data in Table 3 clarifies the understanding of this region. Duplicate tests were initially conducted for tempering temperatures of 171°C (340°F) and above. The values obtained from the VAR TL orientation were 21.9 joules (15.8 ft-lb) and 27.5 joules (19.9 ft-lb) for the 171°C (340°F) temper and 21.0 joules (15.2 ft-lb) and 25.2 joules (18.2 ft-lb) for the 204°C (400°F) temper. Because of this large amount of scatter an additional test was conducted for each of these tempers, plus triplicate tests for a 163°C (325°F) temper for both materials of this orientation. The spread for the 163°C (325°F) temper ranged from 18.0 joules (13.0 ft-lb) to 26.0 joules (18.8 ft-lb) and remained the same for the 171°C (340°F) and 204°C (400°F) tempers. Due to the lack of specimens, it was possible to run only a single test for the LT condition. It is thus evident that in this high hardness tempering range a large number of specimens would have to be run in order to get a good statistical energy value. Also, based on the data generated, there does not appear to be any significant difference between the ESR and VAR energy values. The impact results reveal the tempered martensite embrittlement in the 260°C (500°F) to 371°C (700°F) tempering temperature range.

Fracture Toughness

Fracture toughness data are plotted in Figure 9. Because of non-conformance with ASTM E-399 test procedures these values must be expressed as K_Q and not K_{IC} . VAR values are higher than ESR values for both the LT and TL orientations for tempering temperatures up to 427°C (800°F). Over the tempering temperature range of 163°C (325°F) to 260°C (500°F), the respective average values were 54.9 (50), 59.3 (54), 70.3 (64), and 75.8 (69) $\text{MPa}\sqrt{\text{m}}$ ($\text{ksi}\sqrt{\text{in.}}$) for the VAR versus 49.5 (45), 51.6 (47), 63.7 (58), and 68.1 (62) $\text{MPa}\sqrt{\text{m}}$ ($\text{ksi}\sqrt{\text{in.}}$) for the ESR processed material. There is very little anisotropy evidenced in the fracture toughness data.

The fact that the ESR values were lower than the VAR values is surprising. Fatigue studies conducted by the steel producer showed a similar trend. SEM work on the two materials, which will be discussed in the next section of the report, associates the lower ESR data with inclusions which were picked up from the slag during remelting.

Microstructure

Metallographic examination of the VAR and ESR materials showed comparable prior austenite grain sizes and tempered martensite substructures. However, SEM analytical fractography of toughness specimens revealed 3-20 m calcium aluminate inclusions in the ESR material which were absent in the VAR. A typical example is shown in Figure 10. Quantitative inclusion analysis by the steel supplier confirmed this finding. Relative to the VAR the presence of the aluminates triples the total volume fraction of the inclusions from 0.003% to 0.010% in the ESR. Both steels can be considered "clean" in that the type D oxide inclusion rating would be D1/2T-D1T for both. However, the VAR is quantitatively cleaner due to the absence of the calcium aluminates which were apparently introduced by the calcium-silicon deoxidation treatment during ESR processing. This inclusion difference likely accounts for the slight difference observed in fracture properties.

A parallel study of stress corrosion cracking susceptibility in the same materials* revealed a strong tendency for crack initiation at the ESR aluminate inclusions which had not been encountered in a previous study(3) of numerous ESR 4340 heats. Evidently, the relatively high aluminate content of the ESR material in the present split heat comparison is not typical of properly ESR processed steel but indicates one of the potential difficulties that can be encountered in ESR processing.

CONCLUSIONS

A split heat comparison of ESR and VAR processed 4340 steel shows nearly identical strength and hardness properties. These properties exceed the required specification in the HRC 54-57 range. Ductility measurements were anisotropic for both remelting techniques.

The impact energy absorbed was consistently higher for VAR material tempered from 260°C (500°F) to 649°C (1200°F). Scatter in impact data is significant when tempering from 163°C (325°F) to 204°C (400°F).

The fracture toughness was higher for VAR in both the LT and TL orientations for tempering temperatures up to 427°C (800°F). The lower toughness properties observed in the ESR heat examined were attributed to calcium aluminate inclusions which can be introduced by electroslag remelting.

ACKNOWLEDGMENT

The authors are grateful to Dr. Gregory B. Olson for his helpful discussions and technical assistance in the microscopy work.

*OLSON, G. B., and ANCTIL, A. A. Unpublished Research, AMMRC 1982.

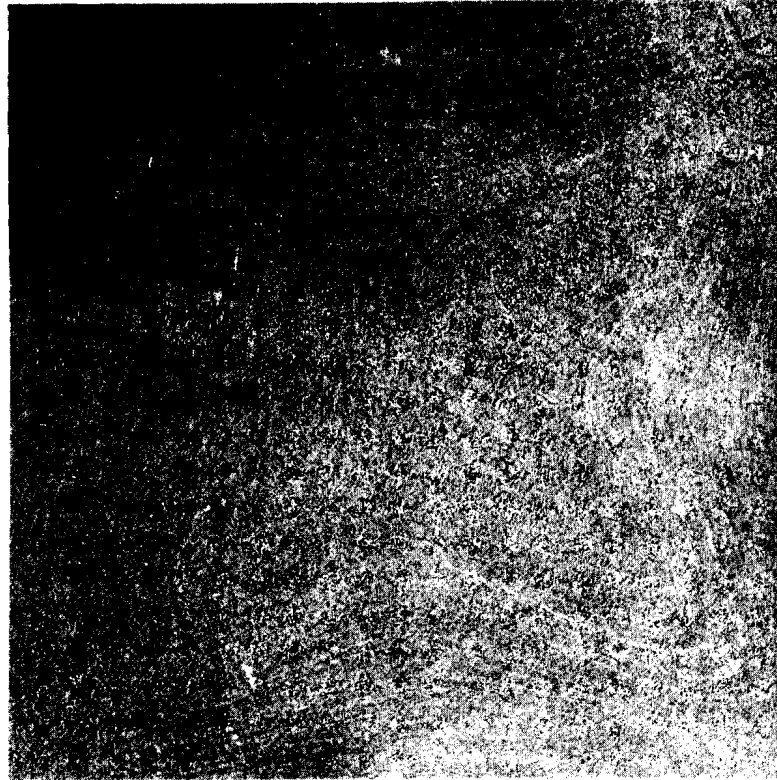

VAR

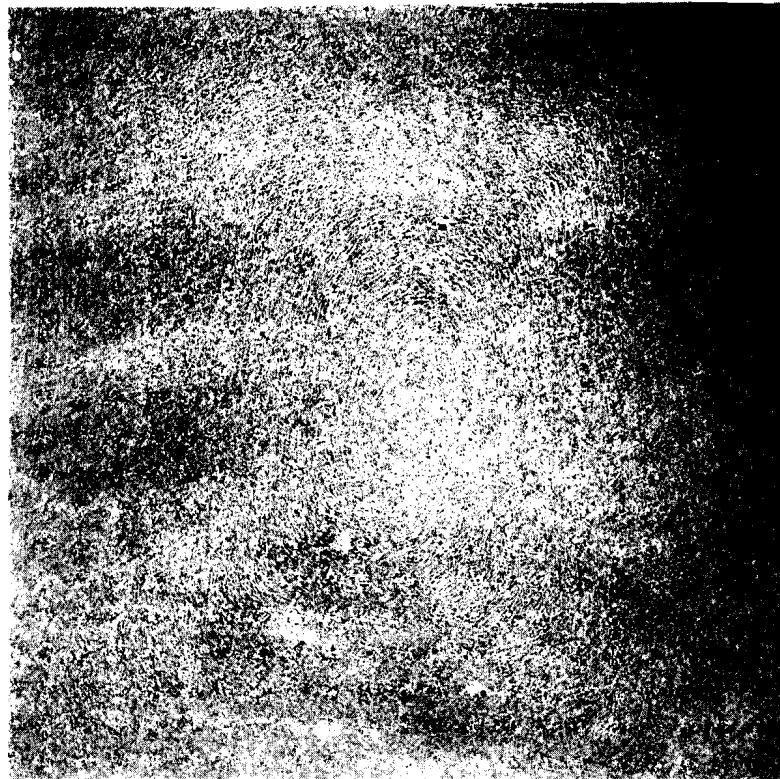

ESR

Figure 1. Photomicrographs of 12.7-cm (5-in)-square forgings. Mag. 1X

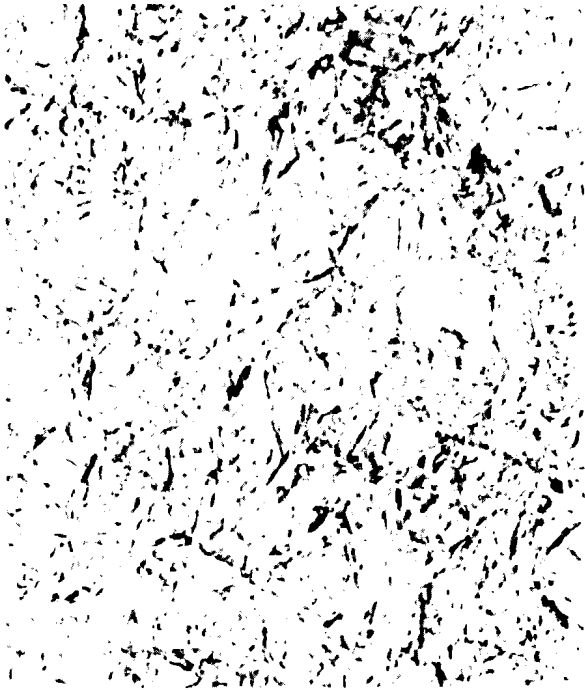

a.

163°C (325°F)



b.

171°C (340°F)

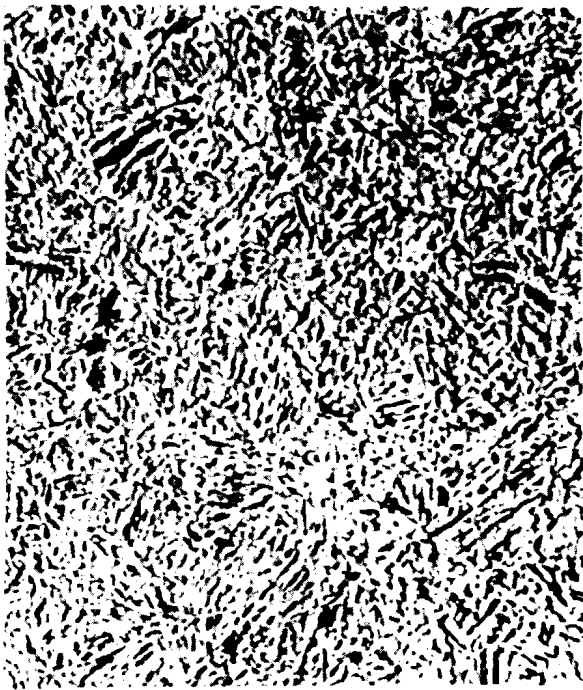

c.

204°C (400°F)

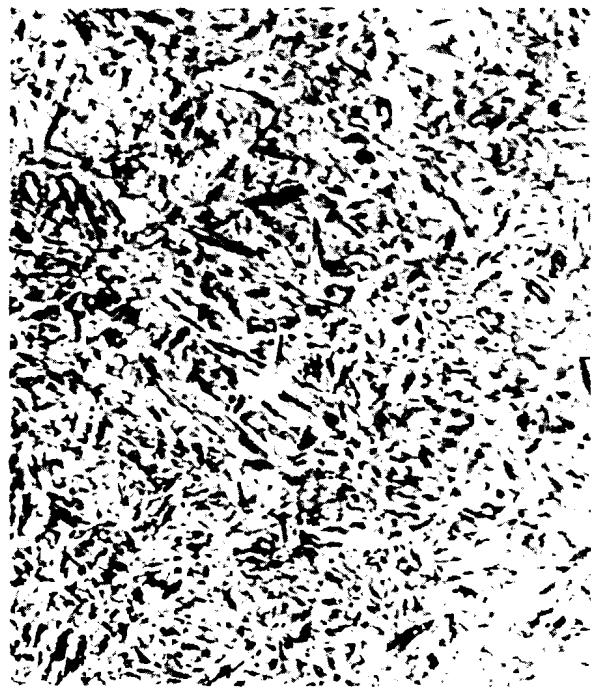

d.

260°C (500°F)

Figure 2. Tempered martensitic microstructure for VAR 4340 steel as a function of tempering temperature.
Mag. 500X - Picral etch

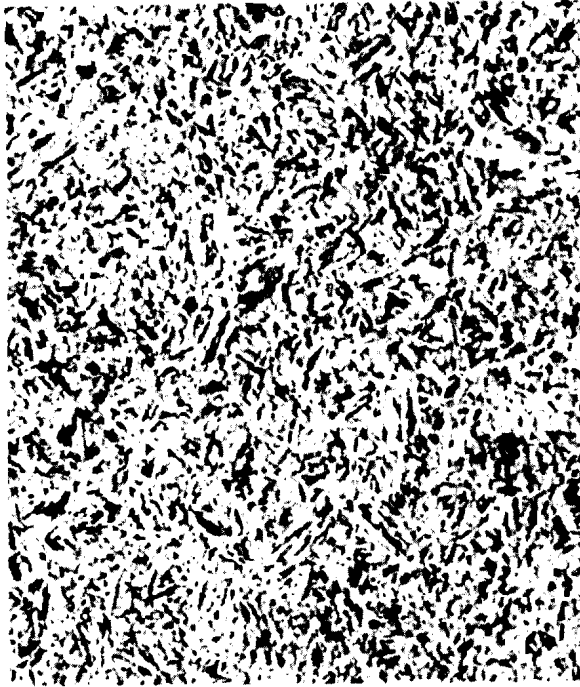

e.

316°C (600°F)

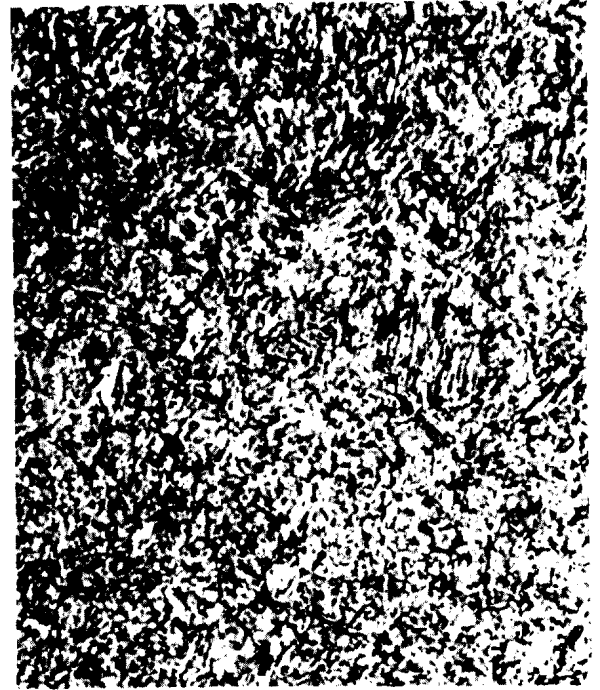

f.

427°C (800°F)

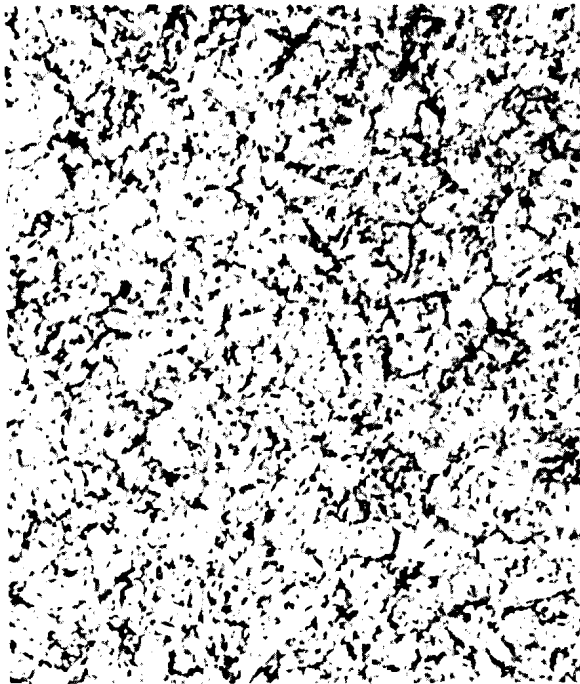

g.

538°C (1000°F)

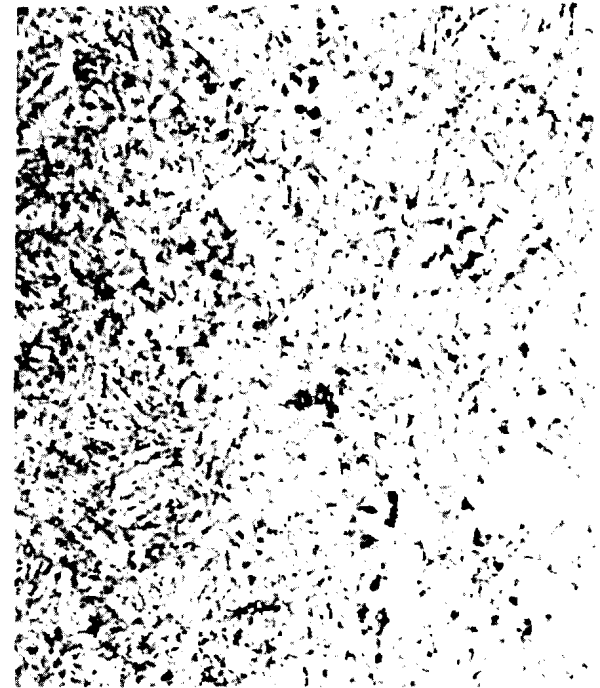

h.

649°C (1200°F)

Figure 2. Tempered martensitic microstructure for VAR 4340 steel as a function of tempering temperature.
Mag. 500X - Picral etch

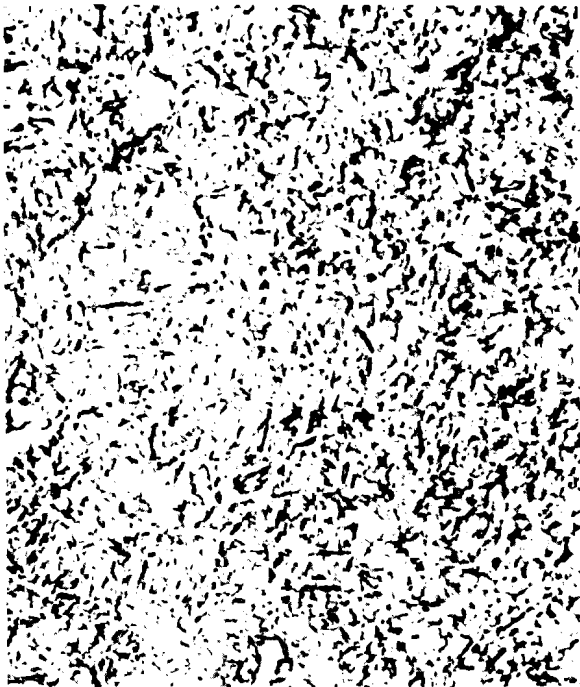

a.

163°C (325°F)

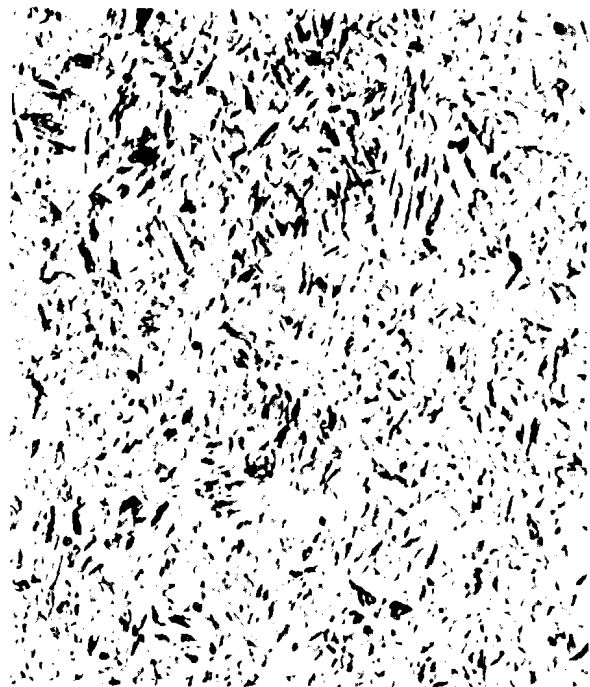

b.

171°C (340°F)

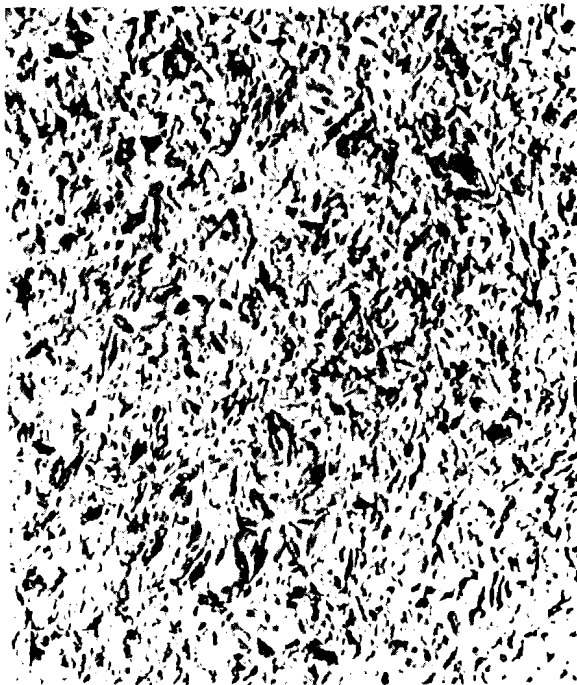

c.

204°C (400°F)



d.

260°C (500°F)

Figure 3. Tempered martensitic microstructure for ESR 4340 steel as a function of tempering temperature.
Mag. 500X - Picral etch

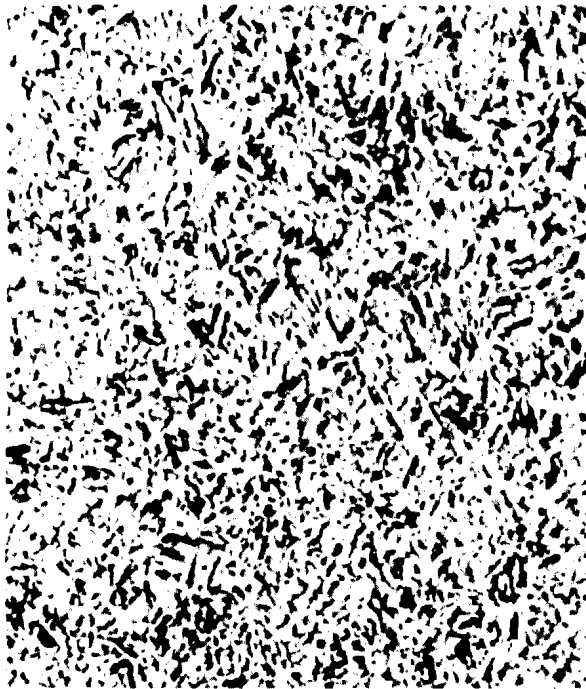

e.

316°C (600°F)

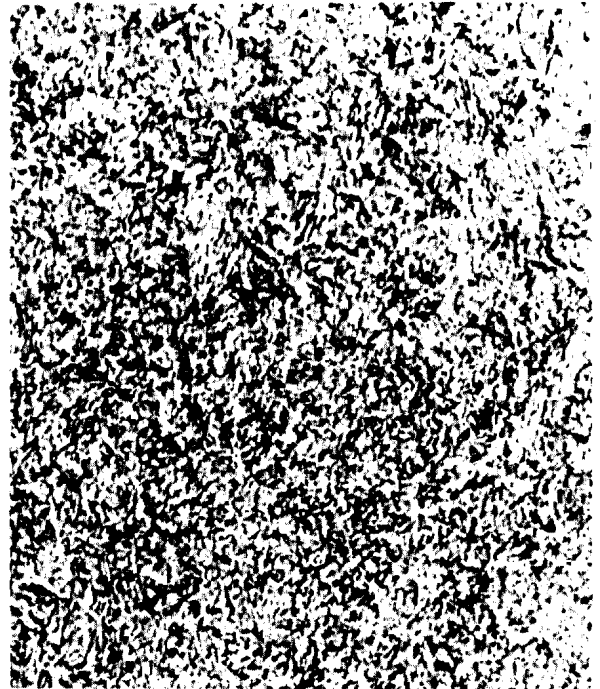

f.

427°C (800°F)



g.

538°C (1000°F)



h.

649°C (1200°F)

Figure 3. Tempered martensitic microstructure for ESR 4340 steel as a function of tempering temperature.
Mag. 500X - Picral etch

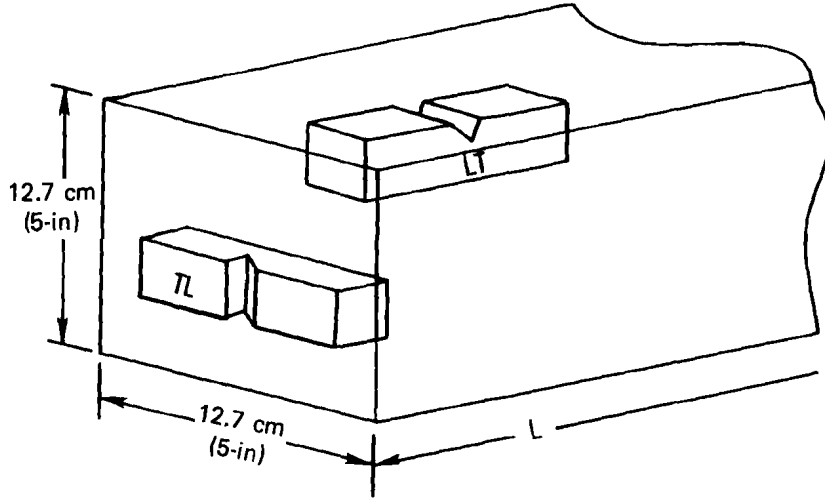

Figure 4. Crack plane identification code for square billet.

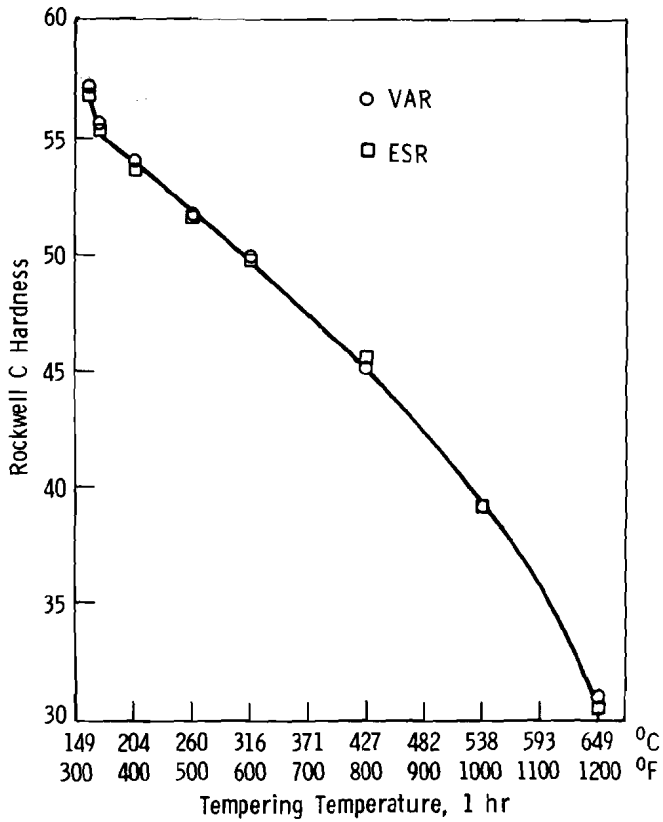

Figure 5. Effect of tempering temperature on hardness.

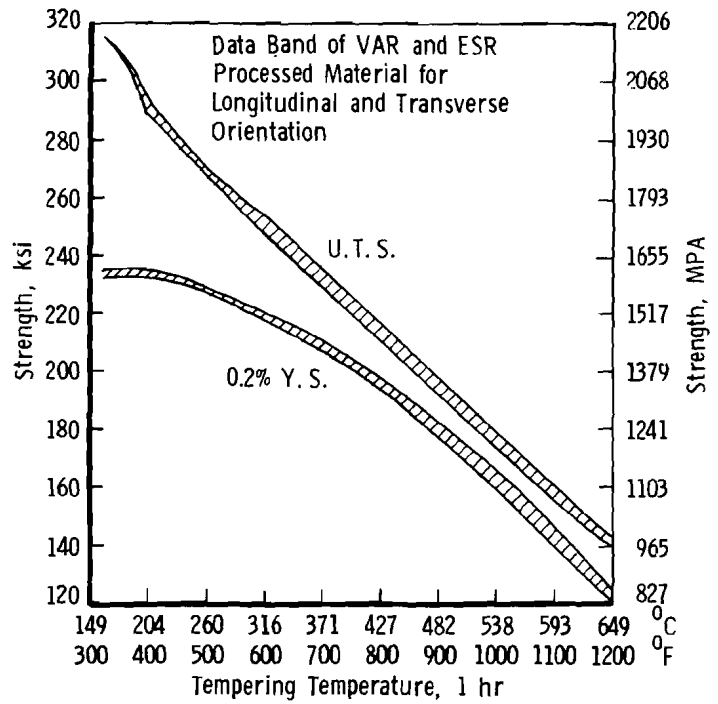

Figure 6. Effect of tempering temperature on yield and tensile strength.

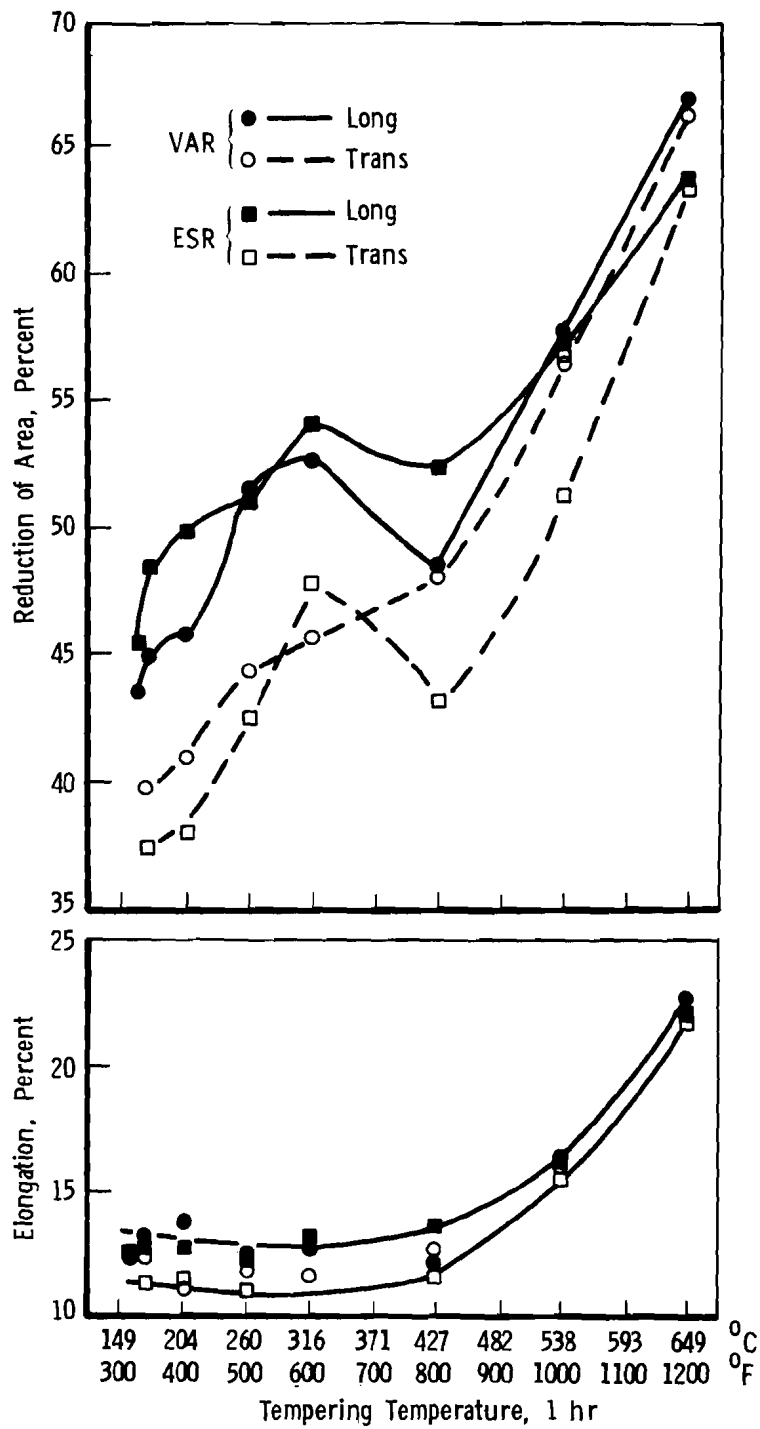

Figure 7. Effect of tempering temperature on ductility.

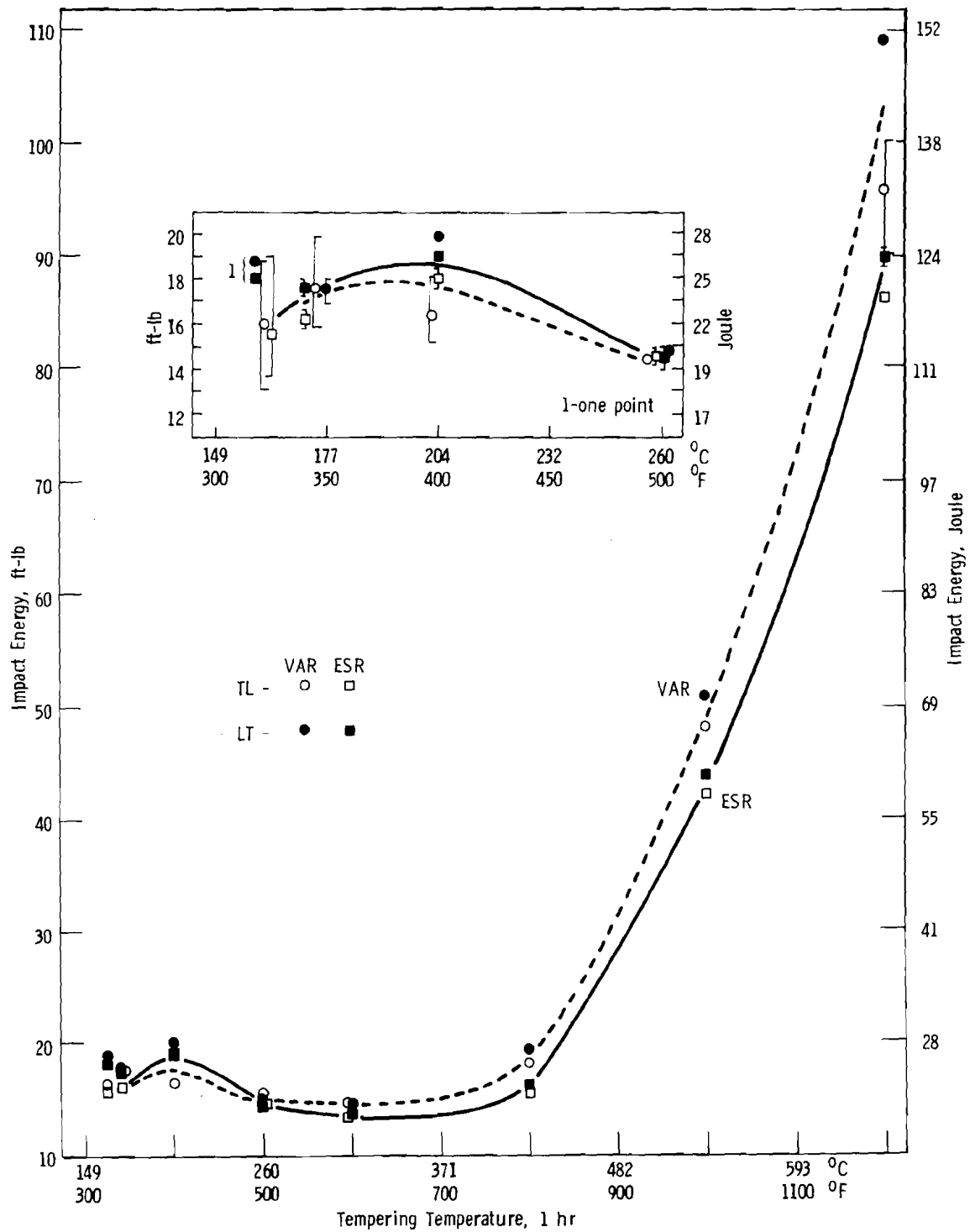

Figure 8. Effect of tempering temperature on impact energy.

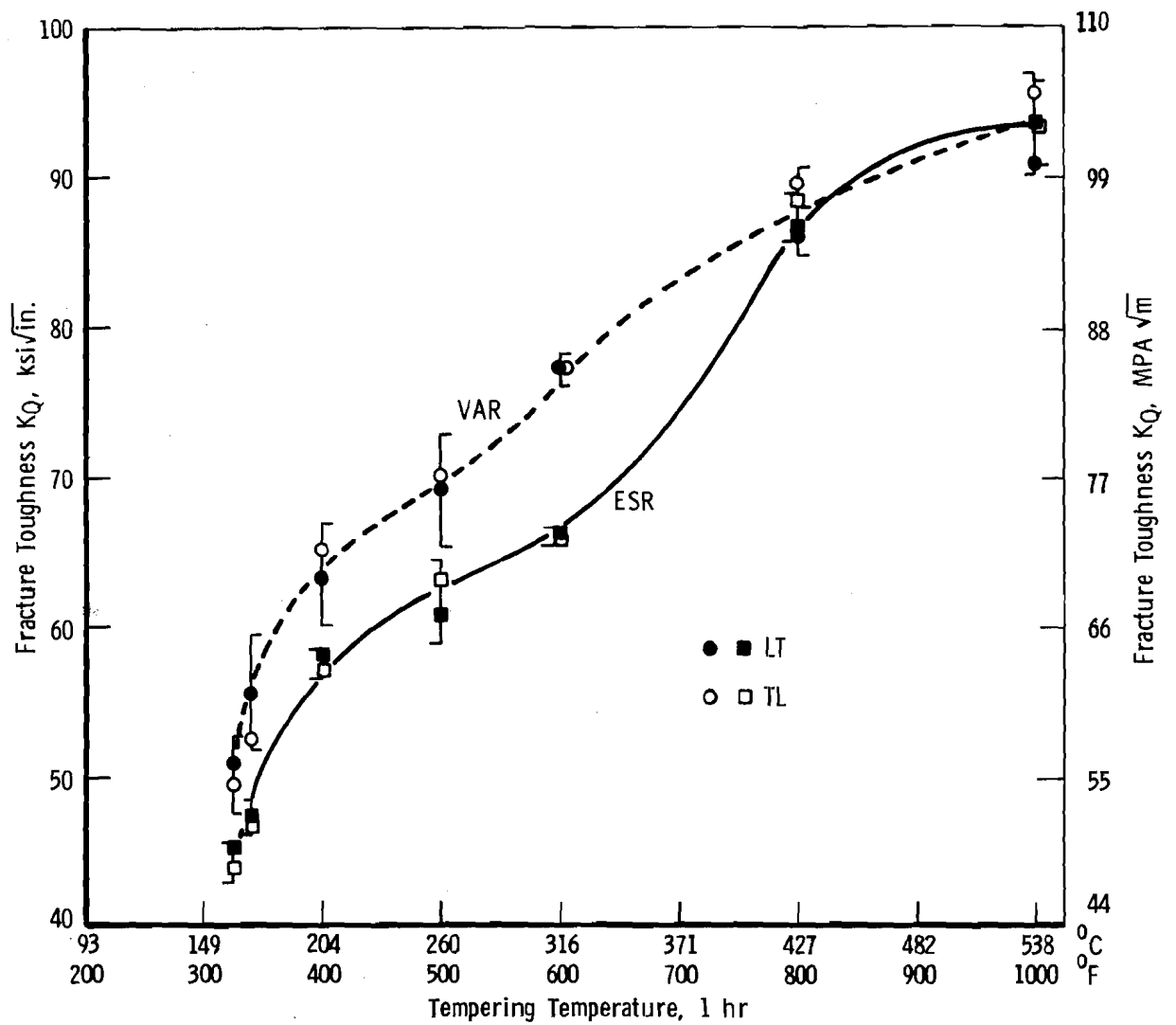
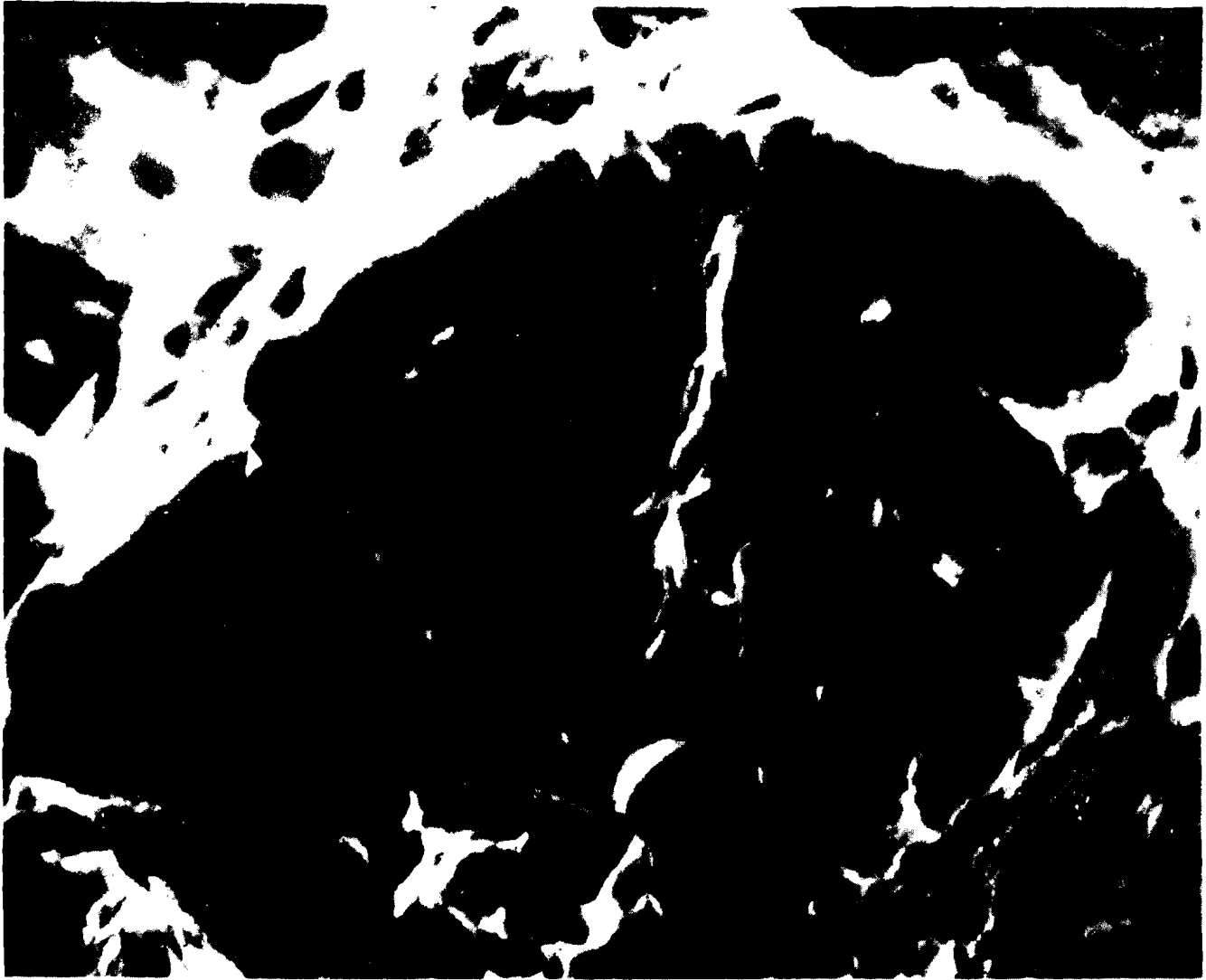

Figure 9. Effect of tempering temperature on fracture toughness.



5 μm

Figure 10. Scanning electron micrograph of the precracked region of an ESR T-L fracture toughness specimen containing a calcium aluminate inclusion