

AD-A141 697

MATRIX-DOMINATED TIME-DEPENDENT DEFORMATION AND DAMAGE  
OF GRAPHITE EPOXY. (U) LAWRENCE LIVERMORE NATIONAL LAB  
CA E M WU ET AL. MAY 83 UCID-19765 AFWAL-TR-83-3056  
W-7405-ENG-48 F/G 11/9

1/6

UNCLASSIFIED

NL

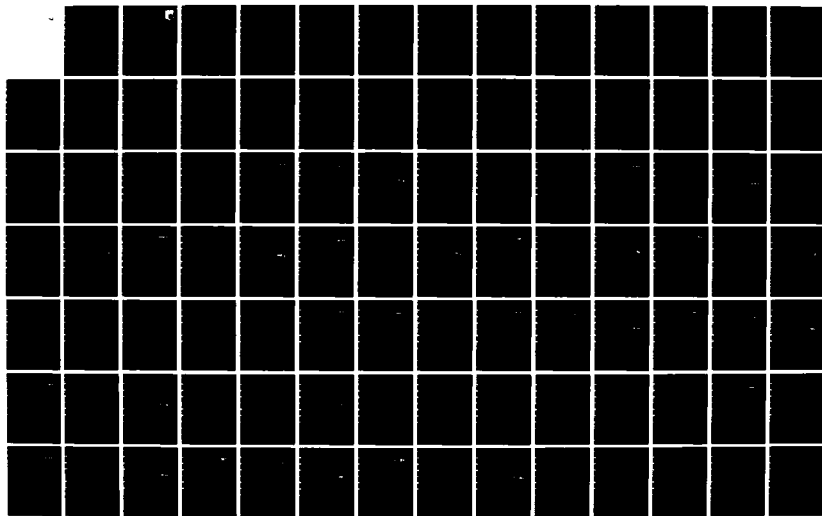

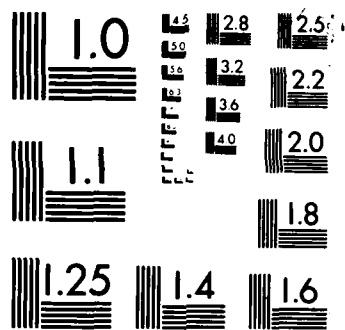

MICROCOPY RESOLUTION TEST CHART  
NATIONAL BUREAU OF STANDARDS 1963-A

AD-A141 697

AFWAL-TR-83-3056

MATRIX-DOMINATED TIME-DEPENDENT DEFORMATION  
AND DAMAGE OF GRAPHITE EPOXY COMPOSITE --  
EXPERIMENTAL DATA UNDER MULTIPLE-STEP RELAXATION



EDWARD M. WU  
NHAN Q. NGUYEN  
RICHARD L. MOORE

Lawrence Livermore National Laboratory  
Livermore, CA 94550

May 1983

INTERIM REPORT FOR PERIOD  
JANUARY 1979 TO DECEMBER 1980

DTIC FILE COPY

Approved for public release; distribution unlimited.

FLIGHT DYNAMICS LABORATORY  
AIR FORCE WRIGHT AERONAUTICAL LABORATORIES  
AIR FORCE SYSTEMS COMMAND  
WRIGHT PATTERSON AIR FORCE BASE, OHIO 45433

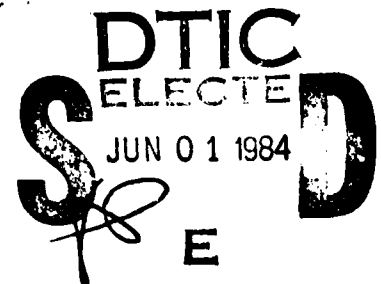

84 05 25 020

NOTICE

When Government drawings, specifications, or other data are used for any purpose other than in connection with a definitely related Government procurement operation, the United States Government thereby incurs no responsibility nor any obligation whatsoever; and the fact that the government may have formulated, furnished, or in any way supplied the said drawings, specifications, or other data, is not to be regarded by implication or otherwise as in any manner licensing the holder or any other person or corporation, or conveying any rights or permission to manufacture use, or sell any patented invention that may in any way be related thereto.

This report has been reviewed by the Office of Public Affairs (ASD/PA) and is releasable to the National Technical Information Service (NTIS). At NTIS, it will be available to the general public, including foreign nations.

This technical report has been reviewed and is approved for publication.

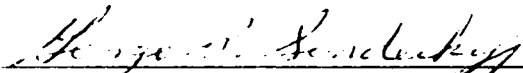
  
GEORGE P. SENDECKYJ, Aerospace Engineer  
Fatigue, Fracture & Reliability Group

  
DAVEY L. SMITH, Chief  
Structural Integrity Branch

FOR THE COMMANDER

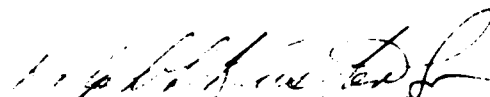
  
RALPH L. KUSTER, JR., Colonel, USAF  
Chief, Structures and Dynamics Division  
Flight Dynamics Laboratory

"If your address has changed, if you wish to be removed from our mailing list, or if the addressee is no longer employed by your organization please notify AFWAL/FIBE, W-PAFB, OH 45433 to help us maintain a current mailing list".

Copies of this report should not be returned unless return is required by security considerations, contractual obligations, or notice on a specific document.

REPORT DOCUMENTATION PAGE		READ INSTRUCTIONS BEFORE COMPLETING FORM
1. REPORT NUMBER AFWAL-TR-87-3150	2. GOVT ACCESSION NO. AD-A141 697	3. REPORTING DATE Interim Period January 1979 - December 1980
4. TITLE (and Subtitle) Matrix-Dominated Time-Dependent Deformation and Damage of Graphite Epoxy Composite - Experimental Data under Multiple-Step Relaxation		5. AUTHOR Edward M. Wu, Nhan Q. Nguyen, Richard L. Moore
7. AUTHOR		9. CONTRACT OR GRANT NUMBER(s) MDR EY 149-81-0014
9. PERFORMING ORGANIZATION NAME AND ADDRESS Lawrence Livermore National Laboratory Livermore, CA 94550		10. PROGRAM ELEMENT PROJECT TITLE AND WORK UNIT NUMBER PE 61102F 2307N10F
11. CONTROLLING OFFICE NAME AND ADDRESS Flight Dynamics Laboratory (AFWAL/FIBE) AF Wright Aeronautical Laboratories Wright-Patterson Air Force Base, Ohio 45433		12. REPORT DATE May 1987
		13. NUMBER OF PAGES 498
14. MONITORING AGENCY NAME & ADDRESS (if different from Controlling Office)		15. SECURITY CLASSIFICATION of this report Unclassified
		15a. DECLASSIFICATION/DOWNGRADING SCHEDULE
16. DISTRIBUTION STATEMENT (of this Report) Approved for public release; distribution unlimited.		
17. DISTRIBUTION STATEMENT (of the abstract entered in Block 20, if different from Report)		
18. SUPPLEMENTARY NOTES		
19. KEY WORDS (Continue on reverse side if necessary and identify by block number) Composites                      Shear damage Graphite-epoxy Shear deformation Multiple step relaxation		
20. ABSTRACT (Continue on reverse side if necessary and identify by block number) The objective of this report is to disseminate experimental data of matrix-dominated time-dependent deformation and time-dependent damage in graphite-epoxy composite. The composite specimens were $\pm 45^\circ$ T300/520 <sup>o</sup> laminate tested in extension with complete instrumentation for stress, strain, and time recordings. Experimental data was recorded and archived in digital form. Noise in the data were minimized by digital elimination of the wild points in the excitation voltage and by a digital valuable low pass frequency filter with		

20. the cut-off frequency matched to the expected materials response. The data were presented both graphically and numerically. Data presented herein is accessible to the technical community at large for correlation and the formulation of theory from diverse perspectives, and to meet different goals in fundamental research and engineering applications.

UNCLASSIFIED

SECURITY CLASSIFICATION OF THIS PAGE (When Data Entered)

## PREFACE

The work reported herein was performed by the Lawrence Livermore National Laboratory under the auspices of the U.S. Department of Energy under contract No. W-7405-ENG-48. Funding was provided by the Flight Dynamics Laboratory of the Air Force Wright Aeronautical Laboratories, Wright-Patterson Air Force Base, Ohio 45433, under MOU/MOA entitled "Spectrum Load/Environment Effects in Advanced Fiber Reinforced Laminates," Project 2307, Work Unit 2307N106. Dr. G. P. Sendeckyj, AFWAL/FIBF, was the Air Force Program Monitor.

This program was conducted by the Materials Test and Evaluation Section of the Mechanical Engineering Department, and the Polymers and Composite Mechanics Program, both of the Lawrence Livermore National Laboratory. The work was directed by Dr. E. M. Wu, experimental mechanics performed by Mr. R. L. Moore, and data reduction software by Mr. N. C. Nguyen.

Part I of this program was reported in AFWAL-TR-82-3076.

<b>Accession For</b>	
NTIS GRA&I	<input checked="" type="checkbox"/>
DTIC TAB	<input type="checkbox"/>
Unannounced	<input type="checkbox"/>
Justification	
By _____	
Distribution/	
Availability Codes	
Dist	Special
<b>A-1</b>	



## TABLE OF CONTENTS

	Page
I. Introduction	1
II. Background and Scope	1
III. Material, Specimen Preparation, and Sample Configuration	2
IV. Experimental Configuration and Procedure	3
V. Data Conditioning	5
VI. Data Smoothing and Data Compaction	6
VII. Data Compilation	8
VIII. Conclusion	9
Appendix I	20
Graphical Compilation of T300/5208 [ $\pm 45^\circ$ ] <sub>S</sub> Graphite-Epoxy in Extensional Multiple-Step Relaxation	
Appendix II	310
Numerical Compilation of T300/5208 [ $\pm 45^\circ$ ] <sub>S</sub> Graphite-Epoxy in Extensional Multiple-Step Relaxation	



## LIST OF FIGURES

<u>Figure</u> <u>No.</u>		<u>Page</u>
1a	Laminate with glass-cloth reinforced tab material (shaded regions).	15
1b	Coupon dimension and configuration.	15
2	Strain gauge configurations for test coupons.	15
3	Overall stress relaxation profile of T300/5208 graphite-epoxy $[\pm 45]_5$ laminate under extensional multiple step displacements.	16
4	Pulse voltage data acquisition system for strain measurement.	17
5a	Data as recorded. Note wild point noise in output signal (stress).	18
5b	Data after elimination of wild points in output voltage (stress) by elimination of wild point noise in input excitation voltage.	19

## LIST OF TABLES

<u>Table</u> <u>No.</u>		<u>Page</u>
1	Numerical tabulation of variations (noise) in the excitation voltage and their statistical parameters.	10
2	Index to graphical and numerical data compilation.	11-14

## SECTION I

### Introduction and Scope

Work reported herein is the second part of a program to provide a data base which can be used to characterize matrix-dominated time-dependent deformation and time-dependent strength. The motivation and scope of this program was outlined in a previous report AFWAL-TR-82-3076. For this report, the material, specimen preparation and sample configuration are the same as described in the first report. The relevant common sections are repeated here for the sake of stand-alone completeness. The experimental configuration and data compilation were unique to the extensional multiple step relaxation history presented in this report.

## SECTION II

### Background and Scope

The structural application of composites with specified reliability targets require quantitative characterization of the composite's time-dependent deformation and time-dependent damage properties. The inherent variability of damage requires extensive replication of tests and a large number of samples. The very nature of time-dependent characterization coupled with the large number of specimen requirements leads to the necessity of occupying testing facilities for extended periods of time. As a matter of practical constraints, it is frequently not feasible to test the numerous permutations of fiber, matrix, lamination geometries, and load-history profiles. Significant reduction of the testing and data managing effort is possible by first characterizing the basic (or local) aspect of time-dependent deformation and damage separately for the fiber and for the matrix, and then by computing the overall composite performance by mechanistic modeling. In graphite/epoxy composites, it is known that the fiber properties are weakly time-dependent; our program is, therefore, directed towards the characterization of matrix dominated time-dependent properties. The specimens are T300/5208,  $\pm 45^\circ$  laminates tested in tension. This configuration characterized the matrix dominated behavior under combined normal and shear stresses as well as interlaminar stresses. Further partitioning of these effects requires

interfacial strength characterization and supplemental testing of the lamina in pure shear and in uniaxial transverse tension. These characterizations were not included in this program.

The scope of this program is to provide a data base which can be used to characterize overall matrix-dominated time-dependent deformation and time-dependent strength. Three load-histories (ramp loading, multiple-step and relaxation loading, creep and recovery loading) were used to facilitate identification of nonlinearity in proportionality and nonlinearity in time-superposition. The data base includes a complete recording of the mechanical stimuli (the input) and the material responses (the output) by macro-variables of stress and strains. Emphasis in this report is on presentation of the data so that it may be accessible to the technical community at large and to facilitate correlation and formulation of mechanistic models from diverse perspectives to meet different goals in fundamental research and in engineering applications. This report is the second part for the program which summarizes the data base established for multiple-step relaxation.

### SECTION III

#### Material, Specimen Preparation, and Sample Configuration

The material tested in this program was Narmco T300/5208 graphite/epoxy currently widely used by the aerospace industries for structural components of high performance aircrafts.

All samples tested were coupons machined from  $[\pm 45]_S$ , i.e., four ply  $\pm 45$  symmetric laminates. The 12" x 12" laminates were fabricated from prepreg tape supplied by the manufacturer. The fabrication method was by vacuum bag molding using scrim cloth to control fiber volume to be  $61\% V_f \pm 2\%$ . The laminates were cured in accordance with the manufacturer's specification which included 1) evacuate in a vacuum bag, 2) increase temperature from room temperature to  $130^\circ\text{C}$  and hold 1 hour at  $135^\circ\text{C}$ , 3) raise temperature to  $179^\circ\text{C}$  and hold for 2.5 hours with autoclave pressure at 100 psi, and 4) cool down overnight to  $60^\circ\text{C}$ .

The post-cure procedure consisted of 1) a 6-hour ramp to  $204^{\circ}\text{C}$ , 2) hold for 4.5 hours at  $204^{\circ}\text{C}$ , 3) followed by a 6-hour ramp down to room temperature. Commercially available glass-fiber cloth reinforced circuit board material was used to provide jaw cushioning for the tensile coupons. Strips of this glass tab materials were bonded to the 30 cm x 30 cm laminate as shown in Figure 1a.

Coupon samples were machined from the plate by a water-cooled diamond cut-off disk, and then precision drilled in a jig, producing the finished specimen with the configuration indicated in Figure 1b. The finished specimens were inspected for irregularities and machining damage by a 10X stereo microscope. Finally, 350  $\mu$  strain gauges were affixed to the samples as illustrated in Figure 2. Three gauge rosettes ( $0^{\circ}/45^{\circ}/90^{\circ}$ ) were used to collect additional information for identifying damage associated with delamination.

#### SECTION IV

##### Experiment Configuration and Procedure

The history profile of one of the multiple-step relaxation tests is shown in Figure 3.

The multiple-step relaxation test consisted of applying a step-displacement; this displacement was maintained while the load relaxes. After the load relaxation approach the asymptotic level, another step-displacement was superimposed on the previous step and again held for load relaxation. The steps were repeated until terminated by visually observable macroscopic damage.

These multiple-step displacement and relaxation tests were performed on a standard metric-model Instron Testing Machine with five pitch cross-head screws. The specimens were loaded by displacement conditions (which should be distinguished from the classical strain controlled relaxation condition). Because the samples have uniform width, the difference between displacement control and strain control is due to the non-uniformity around the gripping area. For the present configuration, the strain based on grip displacement is approximately 3% greater than the strain measured by the strain gauges. The displacement rate for

each step was nominally constant at 0.02 cm/min (corresponding to 0.2%/min) and the holding time approximately 50 hours. We note that due to machine compliance and grip surface deformation, the resultant strain-rates are not precisely constant. Records of the actual strain-time histories (the input stimuli) and load-time histories (the output responses) are reported for use in constitutive modeling.

For each test sample, the cross-sectional area was measured at three locations over a 2 cm length in the middle of the gauge length. The load generated by displacement inputs was measured by a load cell with a capacity approximately 1.5 times the expected maximum load. Load cell output and linearity were calibrated by dead weight. The engineering stress compiled in this report was computed from the measured load divided by the predeformation area.

The in-plane strains for the samples were measured by 350  $\mu$  strain gauges in the  $0^\circ/90^\circ$  or  $0^\circ/45^\circ/90^\circ$  configurations as shown in Figure 2. Excitation voltage for the strain gauges was supplied by a pulse voltage controlled by a mini-computer. The circuit for this pulse voltage and bridge completion is shown in Figure 4. Functionally, when strain gauge measurement is desired, the computer, via a digital output, actuates a 15 volt voltage source. This voltage source is regulated to 10 volts followed by further fine and coarse adjustments to a reference voltage  $V_{ref}$  as required by calibration. This  $V_{ref}$  is used to power the single strain gauge on the specimen with external bridge completion resistors  $R_1$ . The resistors  $R_1$ ,  $R_2$ ,  $R_3$  are used for bridge balancing at the initial state. The excitation voltage and the output of the bridge are read into the computer via a  $\pm 10$  mV multiplexed analogue to digital converter. After the completion of the reading, the excitation voltage is turned-off by software command. The ratio of the output voltage to the excitation voltage is stored to be used to calculate the strain. This pulse voltage system allowed a sufficiently high excitation voltage to be used without introducing resistance heating in the strain gauge. The accuracy of the strain measurement was limited by 1) the voltage adjusting resistors which caused drift of the regulated voltage, and 2) the long connecting wire run between the strain gauge and the completion resistors. The inaccuracy introduced by the

excitation voltage drift was compensated by normalizing the output voltage by the excitation voltage. Through a design/installation error the resistance of connecting wire was not compensated by a third wire. As a result, the accuracy of the strain measurements were judged to be between 10 to 15  $\mu$ -in/in. The loads were measured by load cell operating at one-half of the rated capacity at the highest load-step. A natural limitation of this system is that at the lowest load-step the load cells were operating at less than 1/20 of its capacity with resulting loss of accuracy and signal to noise ratio. The load cells were also excited by the same pulse voltage system except that no external bridge completion was needed for the full bridge in the load cell (and therefore without the connecting wire resistance compensation error as notes in the strain measurements). Both the input excitation voltage and the output voltage were recorded and stored for conversion to physical load measurements. The signals from the load and strain transducer, together with their excitation, were recorded by a Digital Equipment LSI 11/2 computer via a 12-bit multiplexed analogue to digital converter. The data were stored on a floppy disc and then transferred to a Digital Equipment LSI 11/60 base data archival and data analysis system.

## SECTION V

### Data Conditioning

The strain (or load from the load cell) was calculated using the following relation

$$\epsilon = K \frac{V_{out}}{V_{in}}$$

where K is a constant obtained from shunt calibration. For analogue signals, any drift of the input voltage  $V_{in}$  will give rise to a corresponding drift in the output voltage. The strain is calculated from their ratio; therefore, it is automatically compensated for any drift.

Noise in the input voltage, however, is not self compensated because of discrete sampling circuitry we employed for the computer data acquisition. The

digitizing frequency is not high enough to eliminate the short transient noise. A statistical sampling of such noise occurrence is illustrated in Table I. We observed that the sensitivity to noise (as indicated by the standard deviation of the signal) varied from channel to channel as influenced by local geometry and connecting wire length. For example, in Table I, the  $0^\circ$  strain channel for specimen No. 2 is exceptionally susceptible to noise. From the pooled standard deviation of the noise level, we judge that signals beyond two standard deviations are wild transients and they are eliminated when the following criterion is met:

$$V_{in} \geq V_{ave} + 2\sigma$$

where  $\sigma$  is the standard deviation of the signal voltage.

The result of this noise filtering is shown in Figures 5a and 5b. In Figure 5a, the noise in the output signal (stress) is due to electrical transients. In Figure 5b, the output wild points are eliminated by the above software elimination of the input wild points.

The entire data set was subjected to this elimination of high level noise in the input voltage signals, thereby eliminating the associate transient noises in the output signals. A marked improvement of data quality was achieved.

## SECTION VI

### Data Smoothing and Data Compaction

For each of the eight (8) specimens tested in step relaxation, over 8,000 data points were recorded for the load and strain channels. In order to disseminate these data, we need to smooth out the extraneous noise without altering the data character and compact the data into a smaller set which can still adequately represent the underlying materials response.

For data smoothing, we know from experience that under tension, a  $\pm 45^\circ$  laminate is viscoelastic, and its load relaxation response to a step displacement can be adequately represented by an exponential series using one term of the series



to model the materials response within one decade of material response in time. In our experiment, the response data are piecewise smoothed in ten (10) increments per decade in time. Since the strain input is constant between each step, the smoothing time constant is 1/10th that of the expected materials response. This is a conservative way of data smoothing without the risk of altering the data. The software algorithm we use to smooth the data is as follows:

1. Partition data into ten equal intervals in  $\log t$  for each decade of data.
2. Fit data in time intervals  $m-1$ ,  $m$ ,  $m+1$  to the single term exponential  $y = A \exp B t$ , where  $y$  is the response,  $t =$  time,  $A$  and  $B$  best fit constants by least square.
3. Replace entire  $n$  data point in this time interval  $m$  by  $\bar{y}$  and  $\bar{t}$

$$\text{where } \bar{t} = \frac{\sum_{i=1}^n t_i}{n}$$

$$\bar{y} = A \exp \bar{B} t$$

The last step (No. 3) places a smoothed data point at the centroid of the actual recorded data since the data sample interval is not constant and they were frequently interrupted by electrical power and equipment failure.

Exceptions to this algorithm are:

1. When fewer than three data points occur in the  $m^{\text{th}}$  interval, exponential fit is deleted.
2. When the  $m^{\text{th}}$  interval is at the beginning of the history (i.e., no  $m-1$  interval) exponential fit is performed on the  $m^{\text{th}}$  and  $(m+1)^{\text{th}}$  interval.

3. When the  $m^{\text{th}}$  interval is at the end of the history (i.e., no  $m+1$  interval) exponential fit is performed on the  $(m-1)^{\text{th}}$  and  $m^{\text{th}}$  interval.

Using this algorithm, we smooth the data in accordance to the expected material behavior and compact the entire data set to 10 data points per decade of time. This algorithm in effect performs as a time varying low-pass filter where the cut off frequency is lowered logarithmically for increasing time. It is readily seen that this filtering matches with the instantaneous physical behavior (under constant strain) when the relaxation response is logarithmically deminished with time.

## SECTION VII

### Data Compilation

The presentation of the test data is graphical and numerical. Each specimen was tested in displacement control, therefore the  $0^{\circ}$  strain can be interpreted as the mechanical stimuli to the sample. The stress and  $90^{\circ}$  and  $45^{\circ}$  strain (when measured) are the material responses. The overall stimuli and responses for each specimen are graphically presented in Appendix I. For example, in specimen No. 1, we observed from the  $0^{\circ}$  strain history that a total of nine steps were applied to the sample. From the stress history we observed the stress relaxation associated with each step displacement; the relaxation became more pronounced at higher displacement levels suggesting non-linearity and possible materials damage. From the  $90^{\circ}$  strain we observed slight strain decrease, especially at large displacement levels indicating time-dependence of the Poisson ratio. Following these overall stimuli and response profiles, the data for each step are magnified and presented both in the original form and in the smoothed, thinned, and compacted form. By comparing the pair of graphs, a visual verification of the appropriateness of the digital filter can be confirmed. For example, in the  $90^{\circ}$  strain for step No. 1 of specimen No. 1, we observed that, even with heavy thinning for compaction, the character of the data is still preserved. Following this presentation pattern, the data for each step for each

specimen are sequentially presented. For some of the samples, (e.g., specimen No. 8, step No. 12) large fluctuations in stress and strain were observed in final steps of loading. These are consequences of macroscopic local fracture which were confirmed by physical observation of the specimen during testing.

In Part I of this program (ramp-loading) reported in AFWAL-TR-82-3076, the data dissemination was accomplished by fitting an analytic function to the data and the data retrieval was accomplished by substituting appropriate constants (from data fit) into the function. This procedure is not possible here because the load-history profile is much more complex and cannot be fitted to a tractable function. Thus, we are using the directed numerical printout of the compacted data which were compiled in Appendix II. The order of compilation of the numerical data for each specimen by increasing loading steps is identical to the order of their graphical presentation in Appendix I.

Table 2 provides an index to the graphical and numerical data compilation, cross referring to the specimen number and displacement steps.

## SECTION VIII

### Conclusion

We reported on the experimental configuration procedure and in testing  $\pm 45^\circ$  T300/5208 graphite laminates in step-relaxation experiments consisting of eight or nine steps. A special digital filter with time varying cut off frequency low pass filter was developed to smooth and compact the data set. The data set was presented both graphically and numerically for dissemination and retrieval among the composite community at large for correlation and formulation of constitutive models.

06765

TABLE 1.

Numerical Tabulation of Variations (Noise) in the  
Excitation Voltage and their Statistical Parameters

## Specimen No. 1

LOAD		0 Degree STRAIN		90 Degree STRAIN	
Excitation (A/D Counts)	Freq.	Excitation (A/D Counts)	Freq.	Excitation (A/D Counts)	Freq.
1386	1	109	1	116	1
1671	2	111	1	122	1
1672	1	112	3	123	108
1680	2	113	1	124	100
1955	1	125	20	125	600
1956	45	126	137	126	1009
1957	485	127	452	127	560
1958	1144	128	883	128	68
1959	766	129	807	129	3
1960	128	130	246	136	3
1961	1	131	25	137	1
Average = 1957.40		Average = 128.19		Average = 125.83	
Std. Dev. = 16.826		Std. Dev. = 1.357		Std. Dev. = 1.150	

## Specimen No. 2

LOAD		0 Degree STRAIN		90 Degree STRAIN	
Excitation (A/D Counts)	Freq.	Excitation (A/D Counts)	Freq.	Excitation (A/D Counts)	Freq.
1698	1	89	3	110	5
1731	4	90	2	111	1
1732	1	106	1	124	100
1946	22	127	11	125	304
1947	201	128	237	126	1020
1948	529	129	707	127	1009
1949	961	130	974	128	100
1950	697	131	571	129	1
1951	155	132	69		
1952	5	133	1		
Average = 1948.49		Average = 129.72		Average = 126.83	
Std. Dev. = 10.835		Std. Dev. = 2.087		Std. Dev. = 1.156	

TABLE 2

Index to Graphical and Numerical Data Compilation

Specimen Number	Step Number	Graphical Data (Page No. in Appendix I)				Numerical Data (Page No. in Appendix II)			
		Input 0°	Response			Input 0°	Response		
			Load	90°	45°		Load	90°	45°
	← Overall	21	21	22	--				
1	1	23	24	25	--	311	311	312	--
	2	26	27	28	--	313	313	314	--
	3	29	30	31	--	315	315	316	--
	4	32	33	34	--	317	317	318	--
	5	35	36	37	--	319	319	320	--
	6	38	39	40	--	321	321	322	--
	7	41	42	43	--	323	323	324	--
	8	44	45	46	--	325	325	326	--
	9	47	48	49	--	327	327	328	--
	→ Overall	50	50	51	--				
2	1	No input	--	--	--	--	--	--	--
	2	No input	--	--	--	--	--	--	--
	3	No input	--	--	--	--	--	--	--
	4	No input	--	--	--	--	--	--	--
	5	52	53	54	--	329	329	330	--
	6	55	56	57	--	331	331	332	--
	7	58	59	60	--	333	333	334	--
	8	61	62	63	--	335	335	336	--
	9	64	65	66	--	337	337	338	--

TABLE 2  
(continued)

Specimen Number	Step Number	Graphical Data (Page No. in Appendix I)				Numerical Data (Page No. in Appendix II)			
		Input 0°	Response			Input 0°	Response		
			Load	90°	45°		Load	90°	45°
	→ Overall	67	67	68	--				
3	1	No input	--	--	--	--	--	--	--
	2	No input	--	--	--	--	--	--	--
	3	No input	--	--	--	--	--	--	--
	4	69	70	71	--	339	339	340	--
	5	72	73	74	--	341	341	342	--
	6	75	76	77	--	343	343	344	--
	7	78	79	80	--	345	345	346	--
	8	81	82	83	--	347	347	348	--
	9	84	85	86	--	349	349	350	--
	→ Overall	87	87	88	--				
4	1	No input	--	--	--	--	--	--	--
	2	No input	--	--	--	--	--	--	--
	3	89	90	91	--	351	351	352	--
	4	92	93	94	--	353	353	354	--
	5	95	96	97	--	355	355	356	--
	6	98	99	100	--	357	357	358	--
	7	101	102	103	--	359	359	360	--
	8	104	105	106	--	361	361	362	--
	9	107	108	109	--	363	363	364	--

TABLE 2  
(continued)

Specimen Number	Step Number	Graphical Data (Page No. in Appendix I)				Numerical Data (Page No. in Appendix II)			
		Input 0°	Response			Input 0°	Response		
			Load	90°	45°		Load	90°	45°
	→ Overall	110	110	111	111				
5	1	112	113	114	115	365	366	367	368
	2	116	117	118	119	369	370	371	372
	3	120	121	122	123	373	374	375	376
	4	124	125	126	127	377	377	378	378
	5	128	129	130	131	379	379	380	380
	6	132	133	134	135	381	381	382	382
	7	136	137	138	139	383	383	384	384
	8	140	141	142	143	385	385	386	386
	9	144	145	146	147	387	387	388	388
	10	148	149	150	151	389	389	390	390
	11	152	153	154	155	391	392	393	394
	12	156	157	158	159	395	396	397	398
	→ Overall	160	160	161	161				
6	1	162	153	164	165	399	400	401	402
	2	166	167	168	169	403	404	405	406
	3	170	171	172	173	407	408	409	410
	4	174	175	176	177	411	411	412	412
	5	178	179	180	181	413	413	414	414
	6	182	183	184	185	415	415	416	416
	7	186	187	188	189	417	417	418	418
	8	190	191	192	193	419	419	420	420
	9	194	195	196	197	421	421	422	422
	10	198	199	200	201	423	423	424	424
	11	202	203	204	205	425	426	427	428
	12	206	207	208	209	429	430	431	432

TABLE 2  
(continued)

Specimen Number	Step Number	Graphical Data (Page No. in Appendix I)				Numerical Data (Page No. in Appendix II)			
		Input 0°	Response			Input 0°	Response		
			Load	90°	45°		Load	90°	45°
	— Overall	210	210	211	211				
7	1	212	213	214	215	433	434	435	436
	2	216	217	218	219	437	438	439	440
	3	220	221	222	223	441	442	443	440
	4	224	225	226	227	445	445	446	446
	5	228	229	230	231	447	447	448	448
	6	232	233	234	235	449	449	450	450
	7	236	237	238	239	451	451	452	452
	8	240	241	242	243	453	453	454	454
	9	244	245	246	247	455	455	456	456
	10	248	249	250	251	457	457	458	458
	11	252	253	254	255	459	460	461	461
	12	256	257	258	259	462	463	464	464
	— Overall	260	260	261	261				
8	1	262	263	264	265	465	466	467	468
	2	266	267	268	269	469	470	471	472
	3	270	271	272	273	473	474	475	476
	4	274	275	276	277	477	477	478	478
	5	278	279	280	281	479	479	480	480
	6	282	283	284	285	481	481	482	482
	7	286	287	288	289	483	483	484	484
	8	290	291	292	293	485	485	486	486
	9	294	295	296	297	487	487	488	488
	10	298	299	300	301	489	489	490	490
	11	302	303	304	305	491	492	493	494
	12	306	307	308	309	495	496	497	498



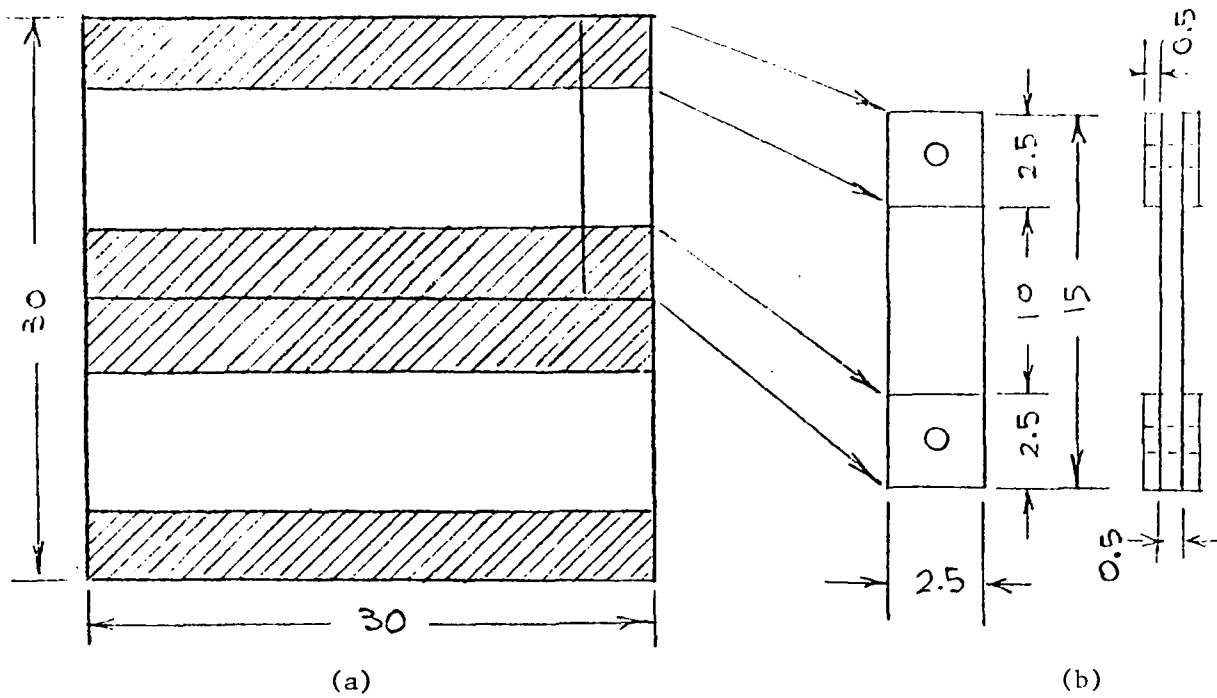

Dimensions in Centimeters

Fig. 1: (a) Laminate with glass-cloth reinforced tab material (shaded regions)  
 (b) Coupon dimension and configuration

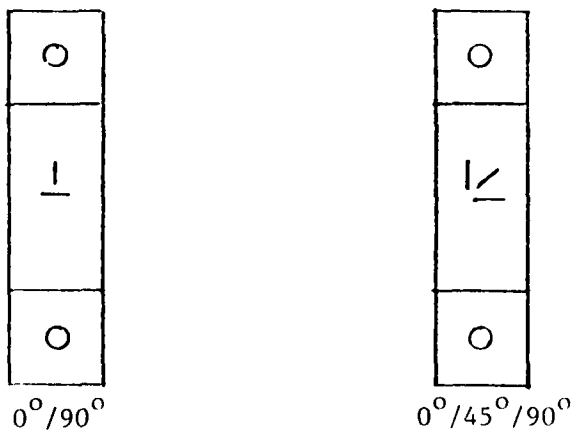

Fig. 2: Strain Gauge Configurations for Test Coupons

T300/5208 - STEP/RELAXATION (RAW DATA)

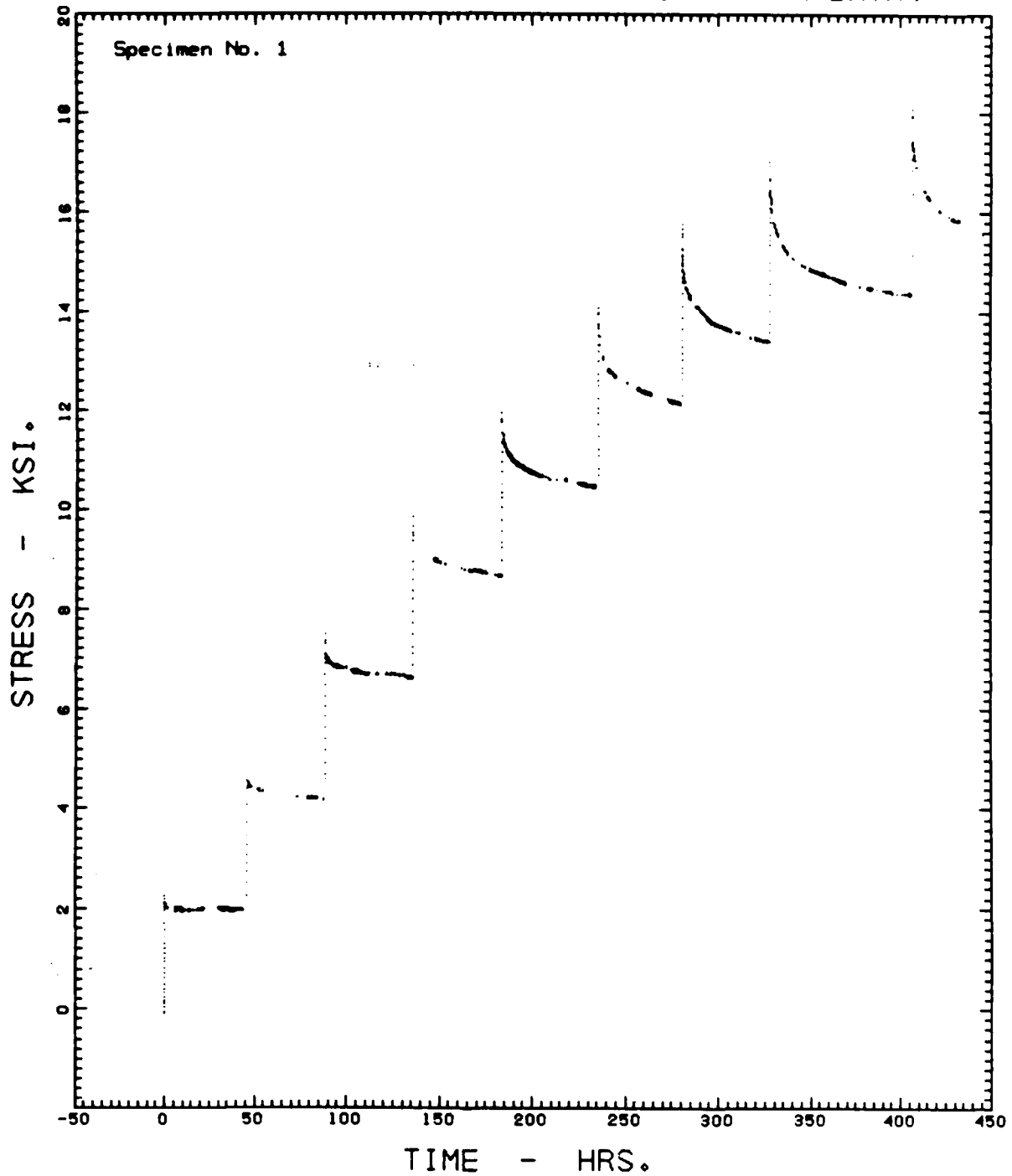

Fig. 3: Overall Stress Relaxation Profile of T300/5208 Graphite-Epoxy  $[\pm 45]_S$  Laminate Under Extensional Multiple Step Displacements.

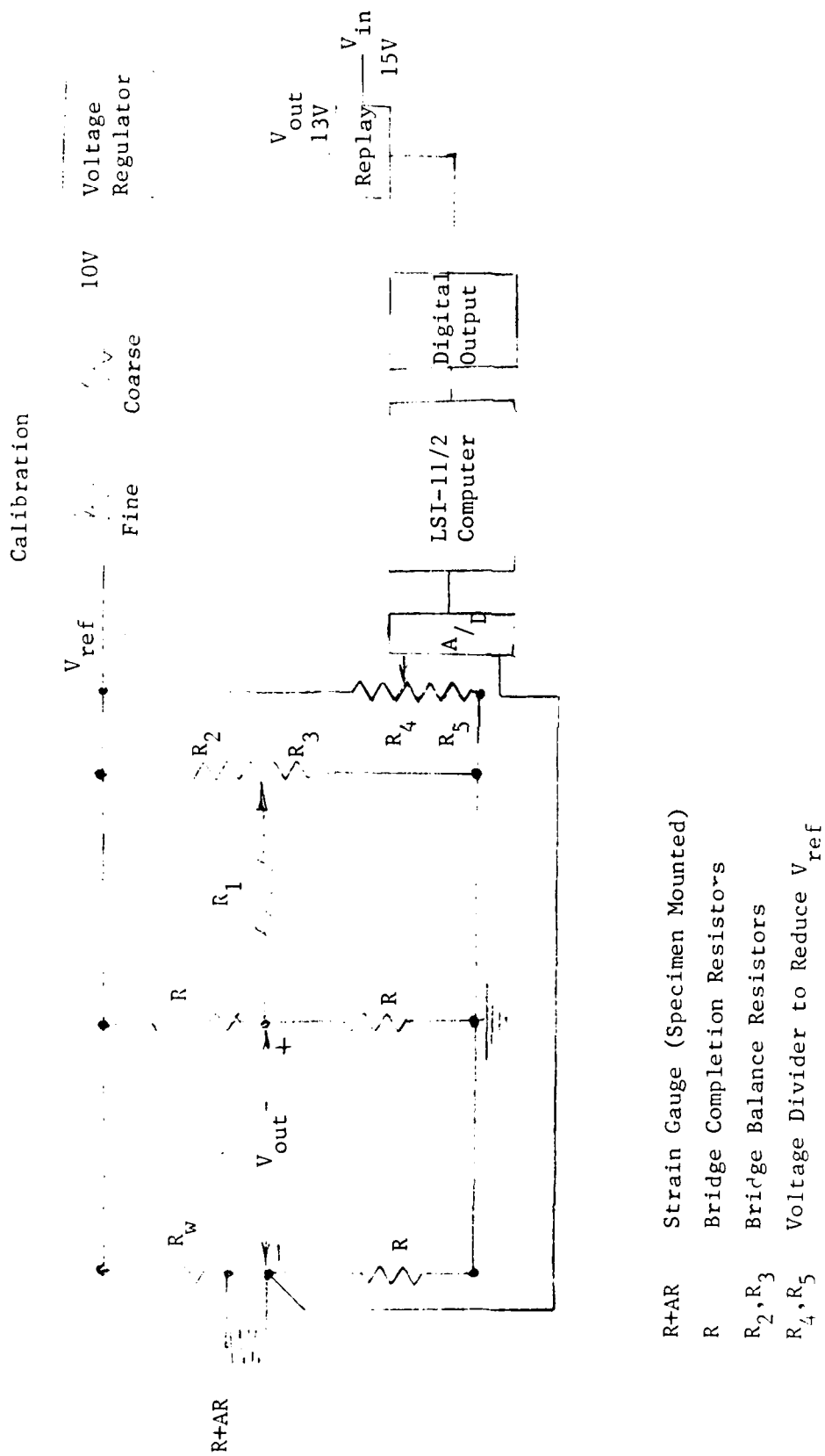

Fig. 4: Pulse Voltage Data Acquisition System for Strain Measurement.

T300/5208 - STEP/RELAXATION - SPECIMEN NO. 1

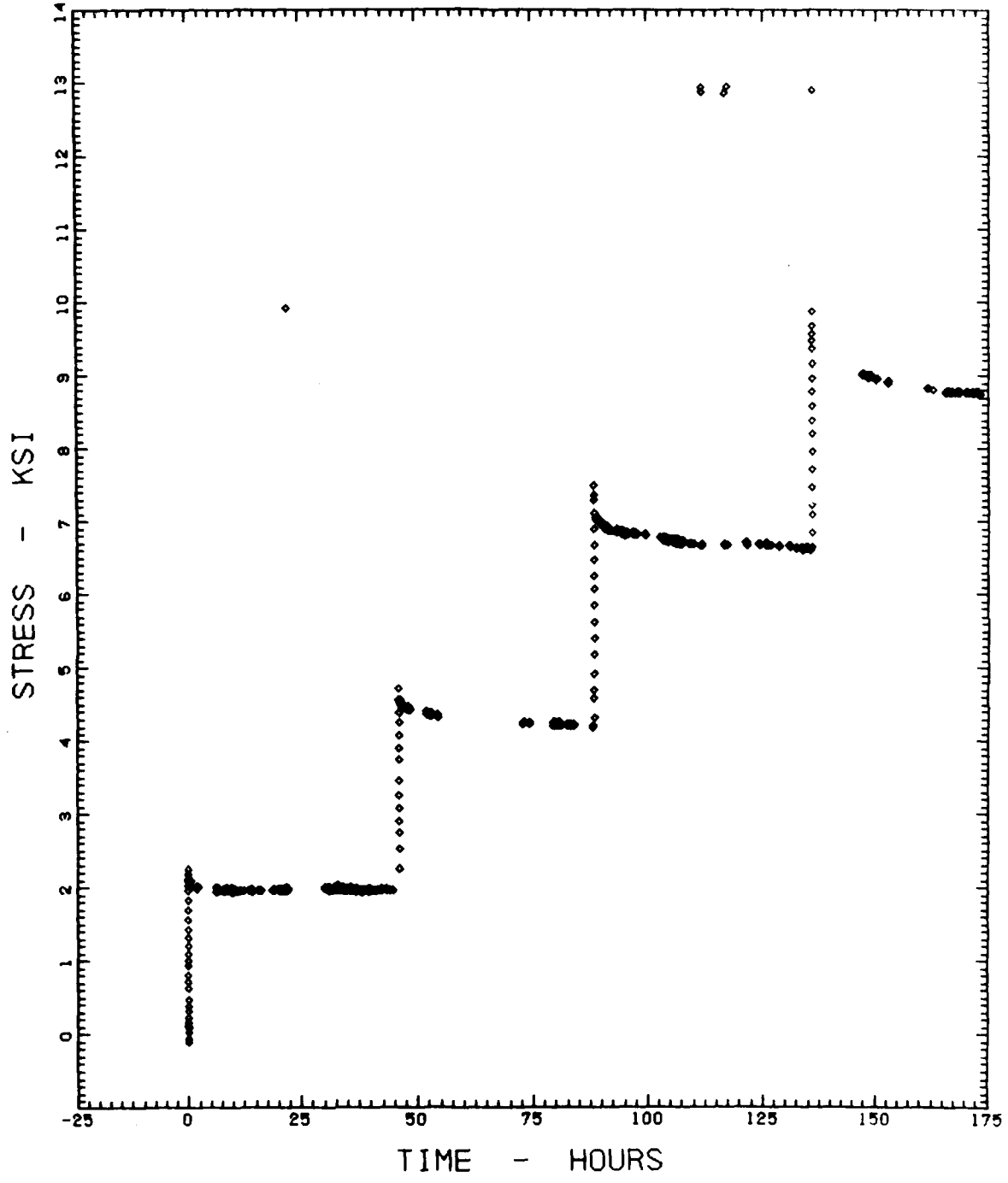

Fig. 5a: Data as recorded. Note wild point noise in output signal (stress).

T300/5208 - STEP/RELAXATION - SPECIMEN NO. 1

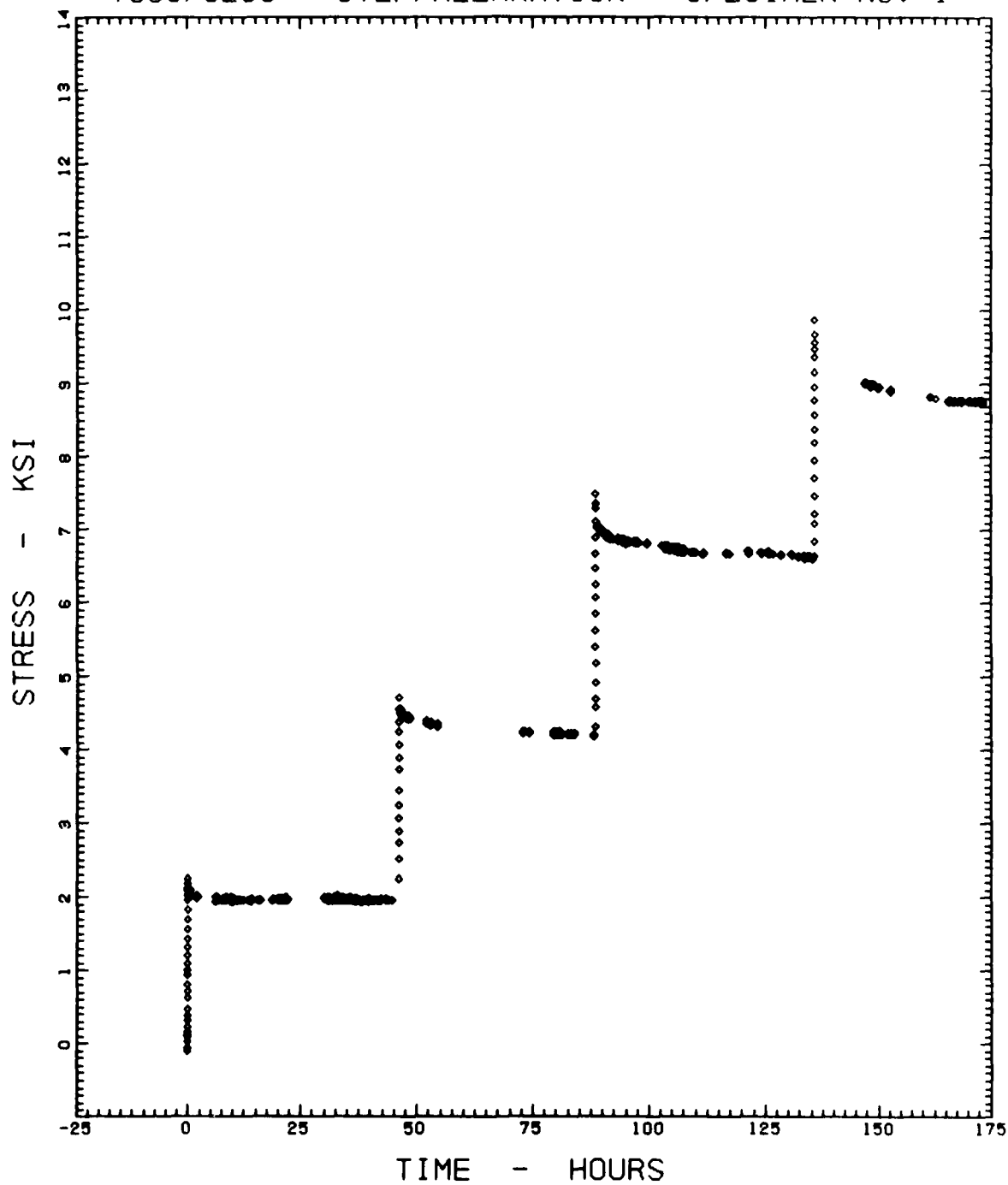
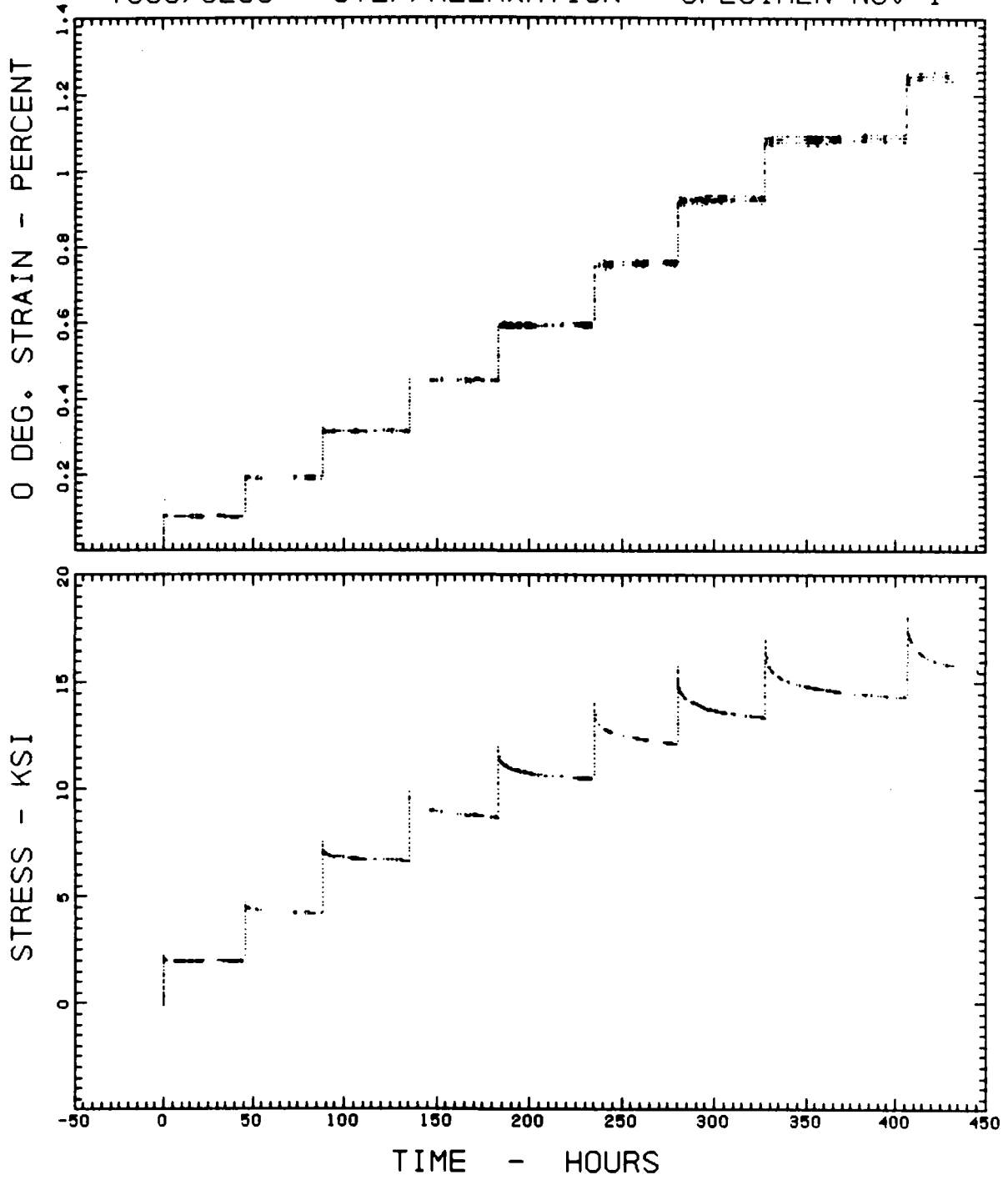

Fig. 5b: Data after elimination of wild points in output voltage (stress) by elimination of wild point noise in input excitation voltage.

APPENDIX I

Graphical Compilation of Stress Strain History of  
Extensional Step-Relaxation Tests -  
T300/5208 [ $\pm 45$ ]<sub>S</sub> Graphite-Epoxy

T300/5208 - STEP/RELAXATION - SPECIMEN NO. 1



T300/5208 - STEP/RELAXATION - SPECIMEN NO. 1

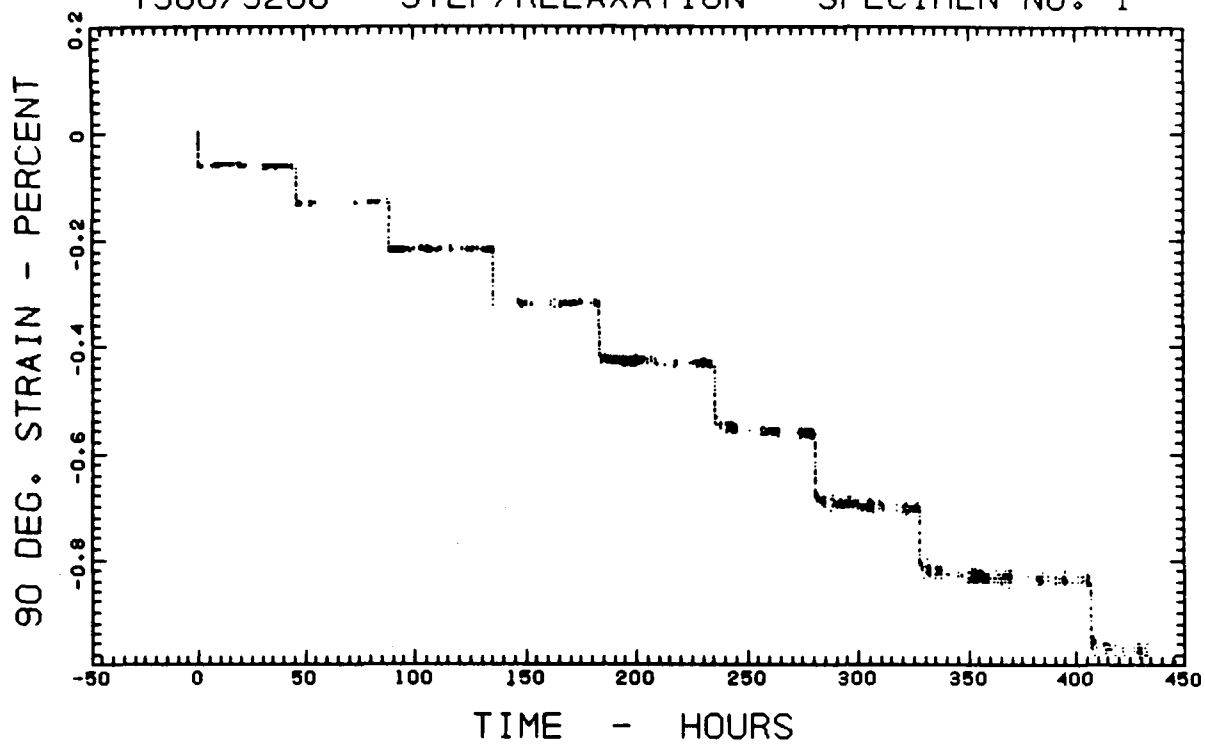



T300/5208 - STEP/RELAXATION - SPECIMEN No. 1 - STEP No. 1

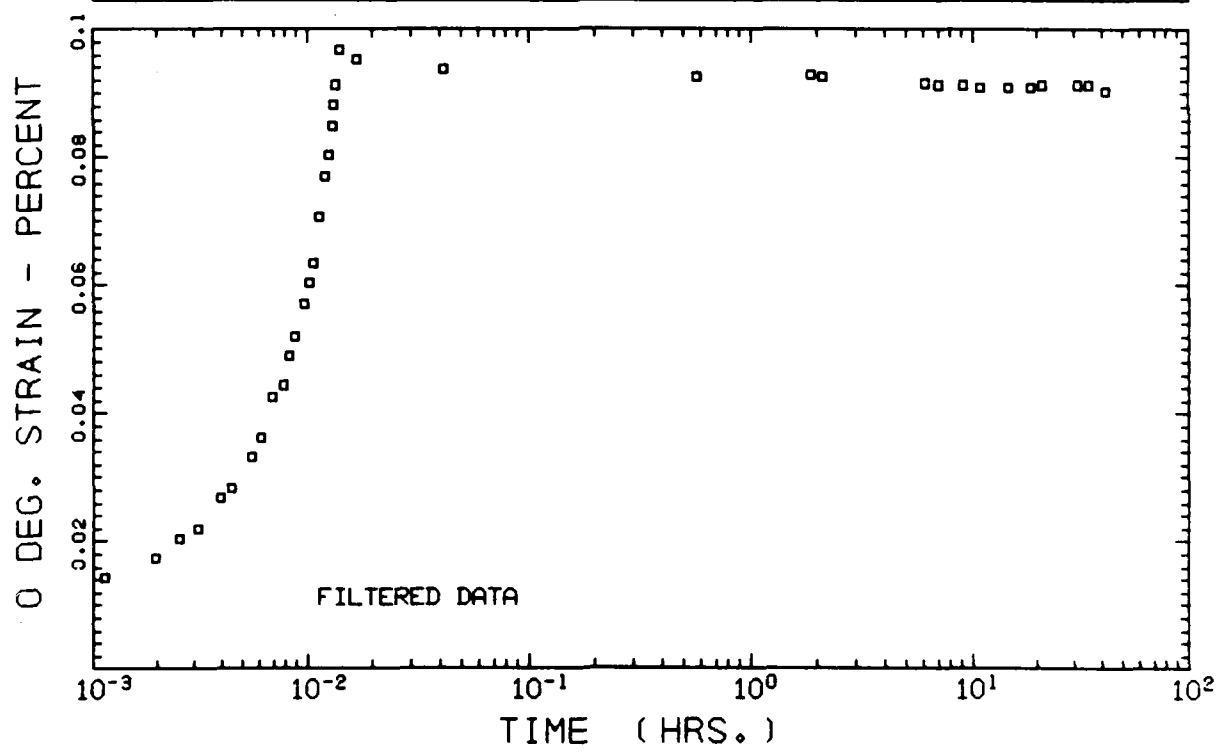
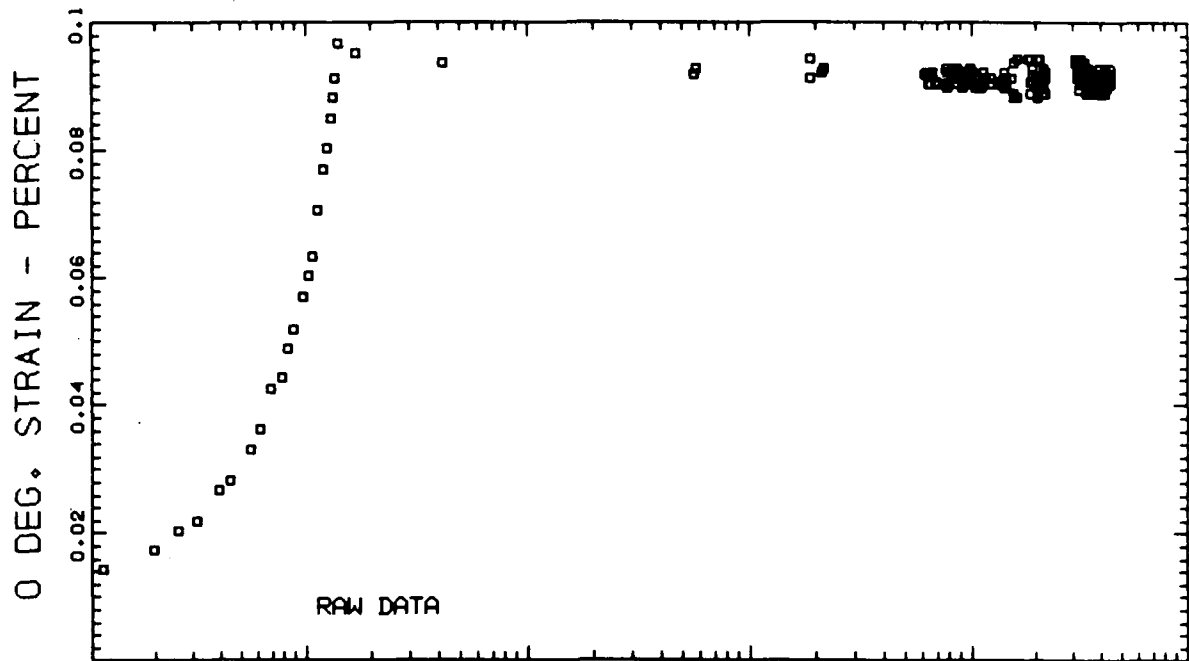

T300/5208 - STEP/RELAXATION - SPECIMEN No. 1 - STEP No. 1

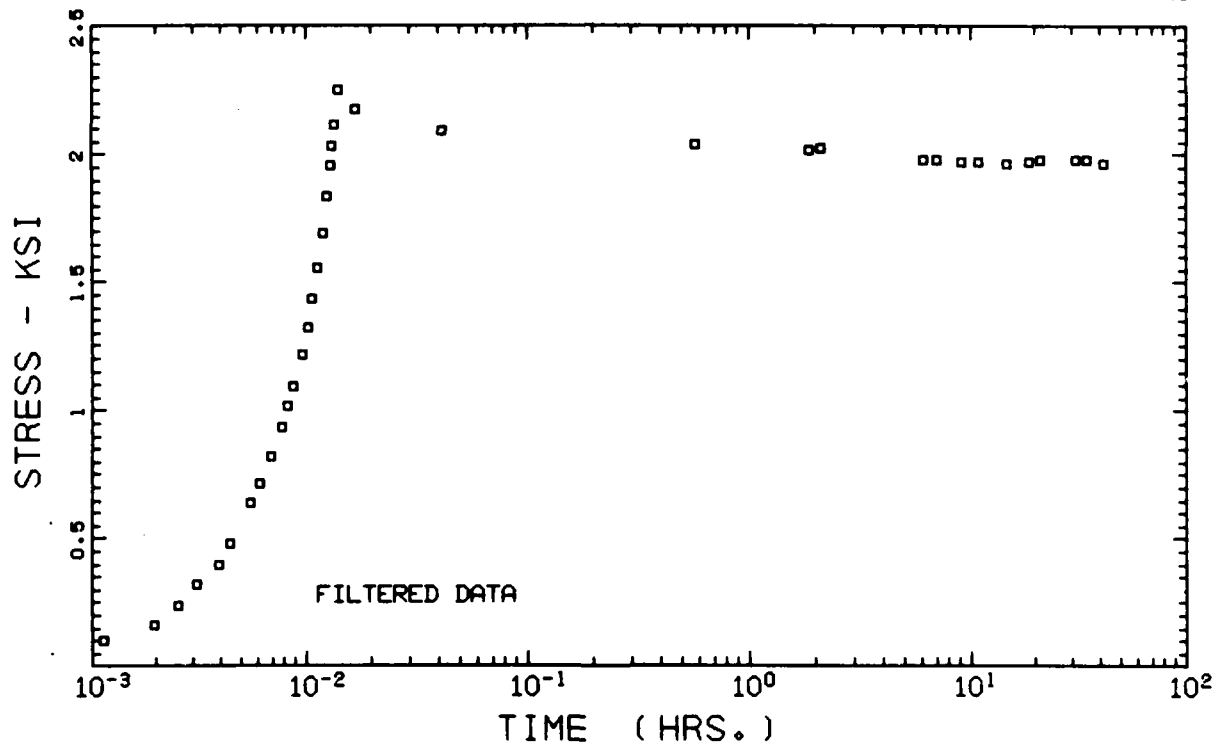
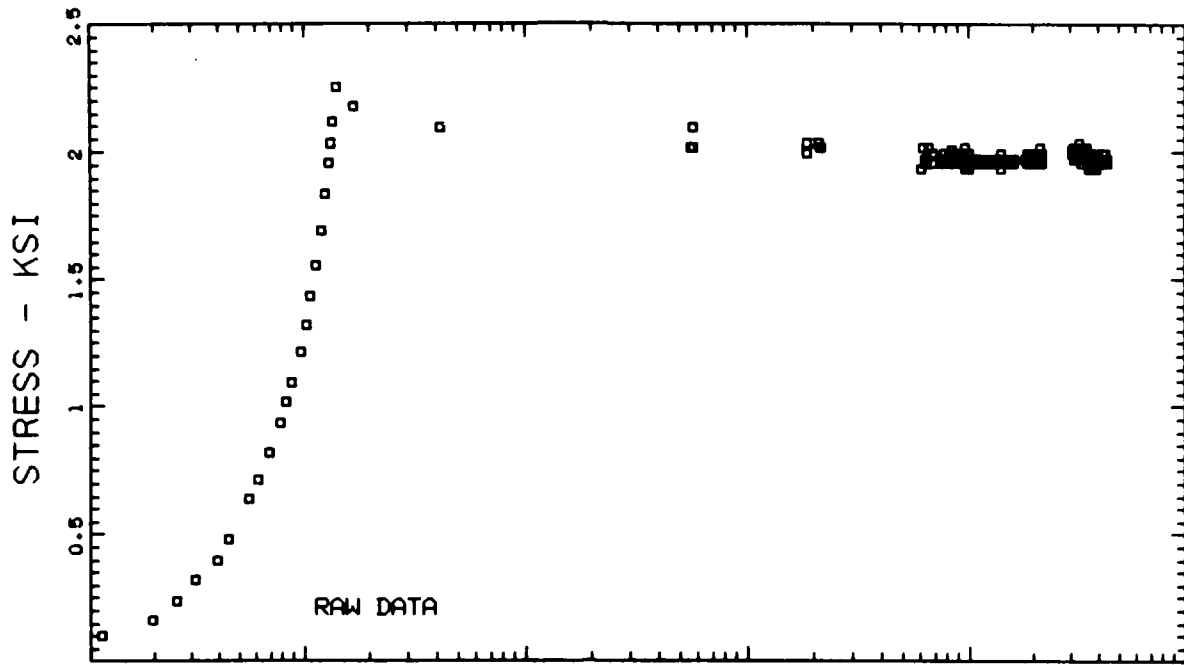

T300/5208 - STEP/RELAXATION - SPECIMEN No. 1 - STEP No. 1

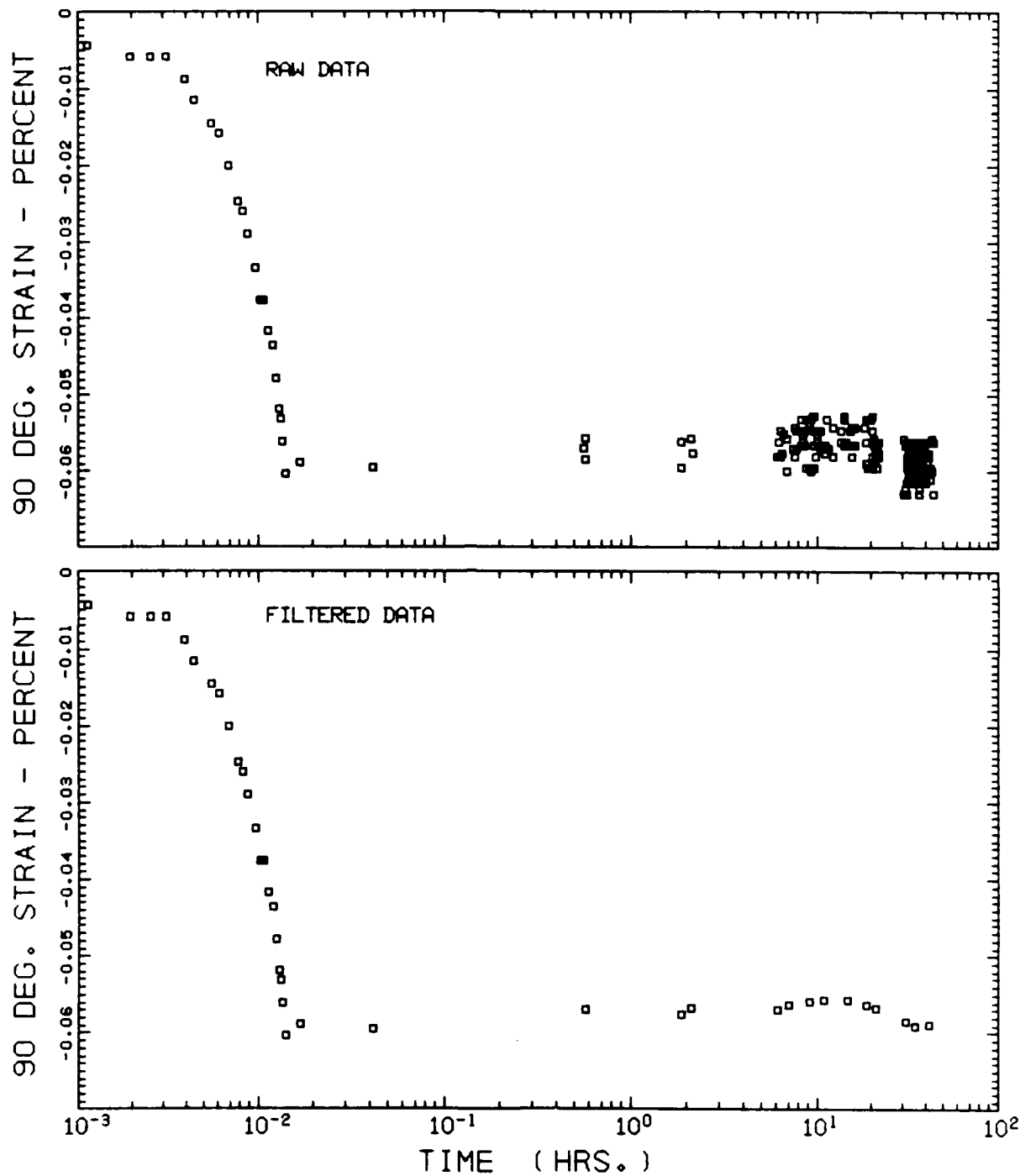

T300/5208 - STEP/RELAXATION - SPECIMEN No. 1 - STEP No. 2

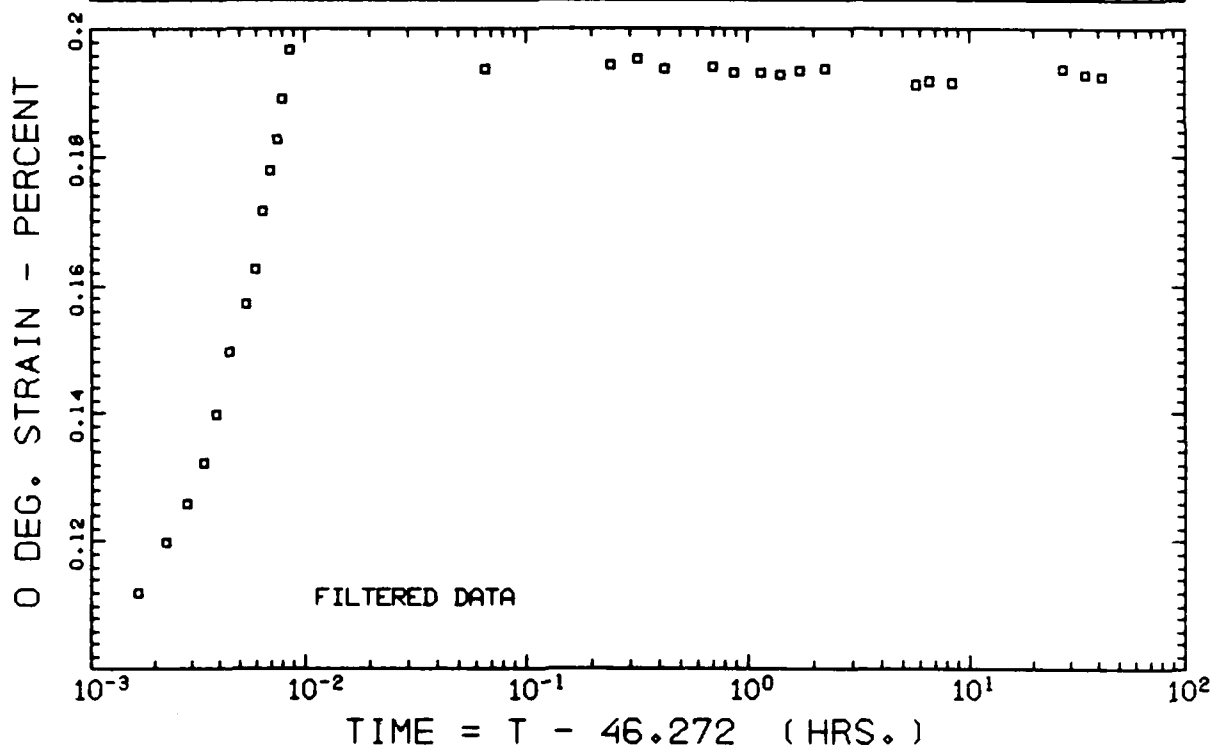
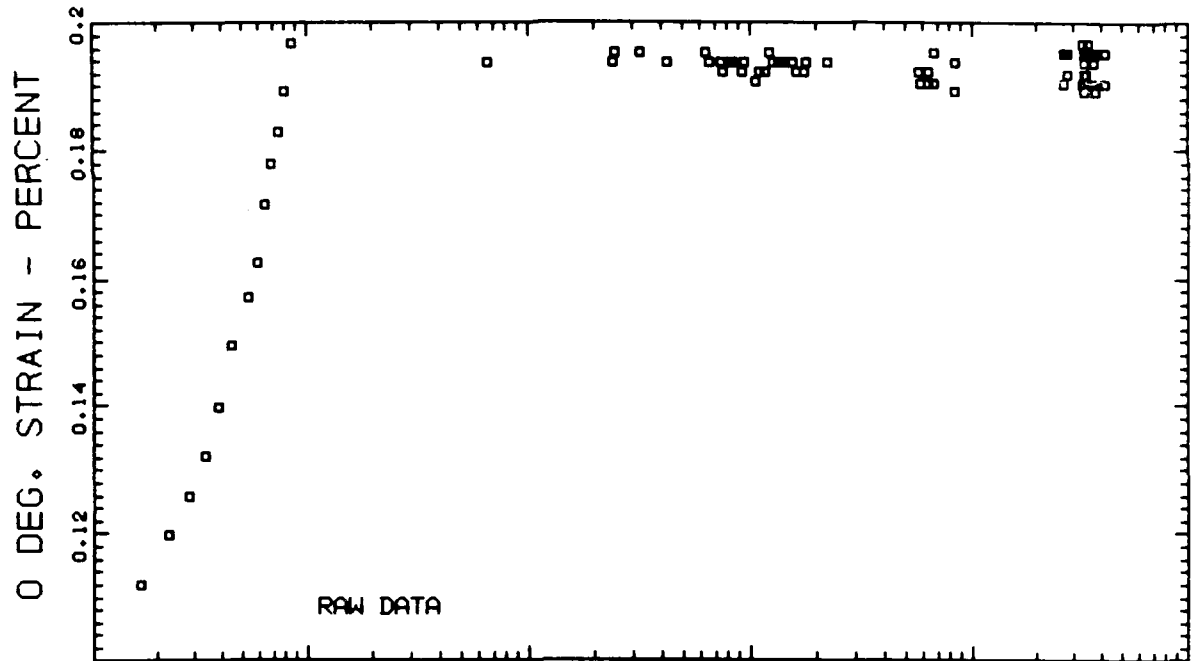

T300/5208 - STEP/RELAXATION - SPECIMEN No. 1 - STEP No. 2

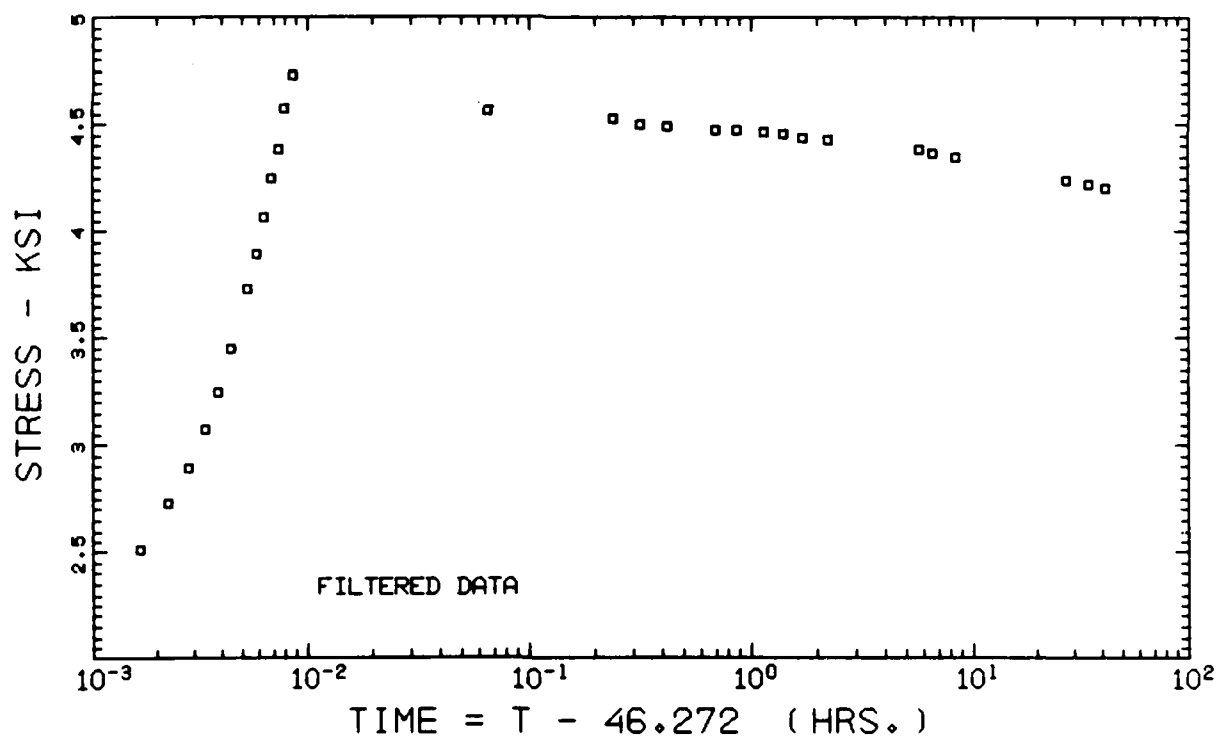
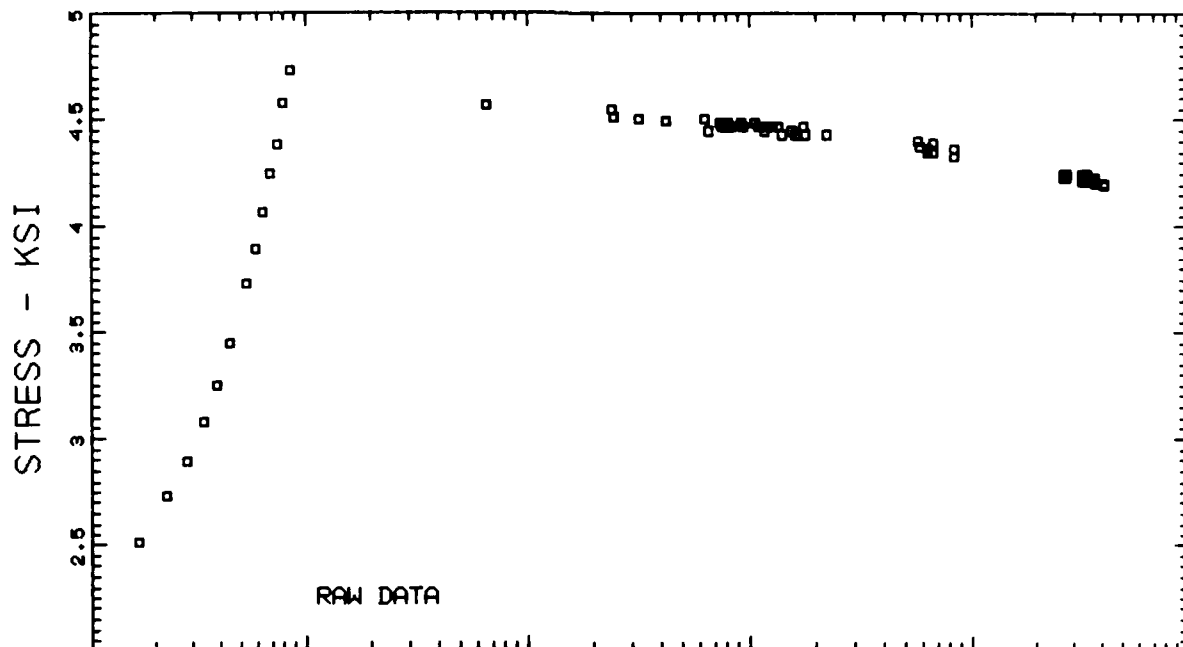

T300/5208 - STEP/RELAXATION - SPECIMEN No. 1 - STEP No. 2

90 DEG. STRAIN - PERCENT

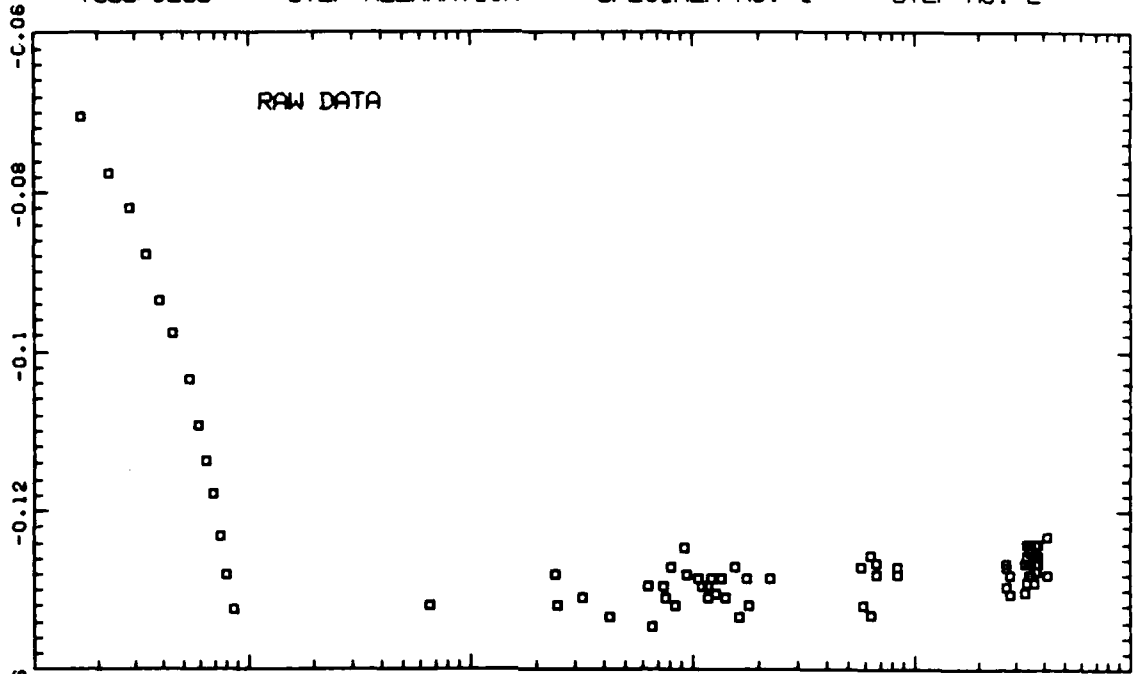

90 DEG. STRAIN - PERCENT

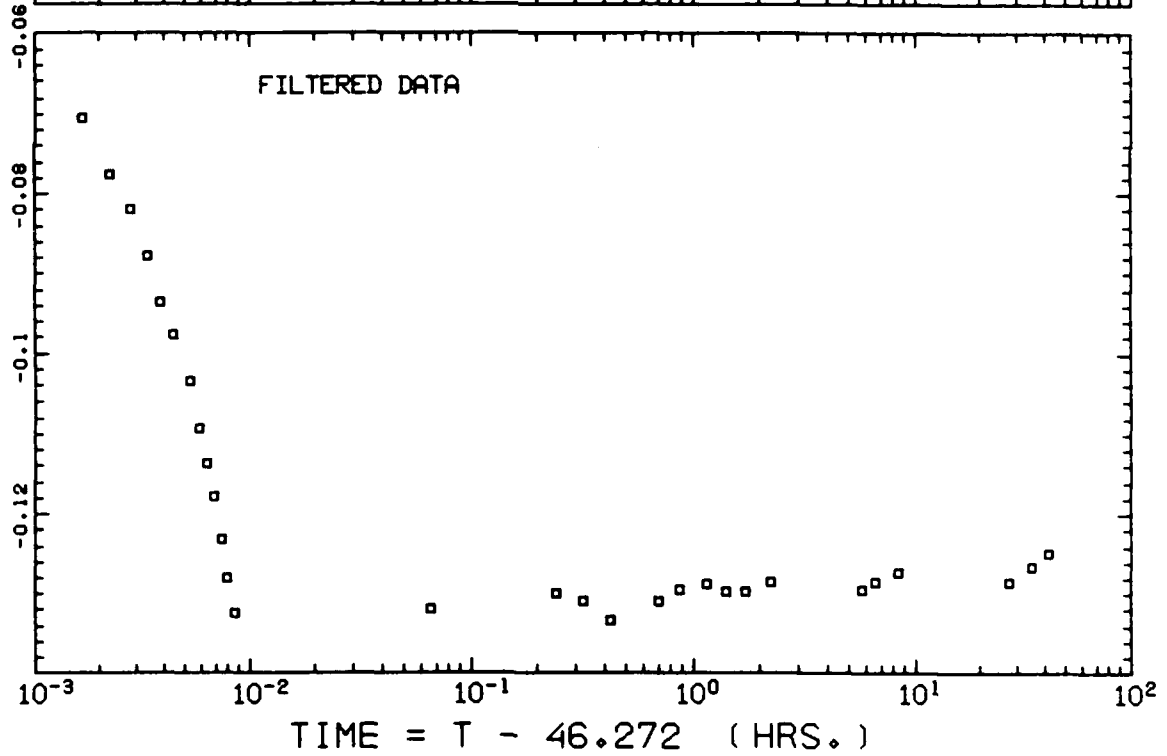

TIME = T - 46.272 (HRS.)

T300/5208 - STEP/RELAXATION - SPECIMEN No. 1 - STEP No. 3

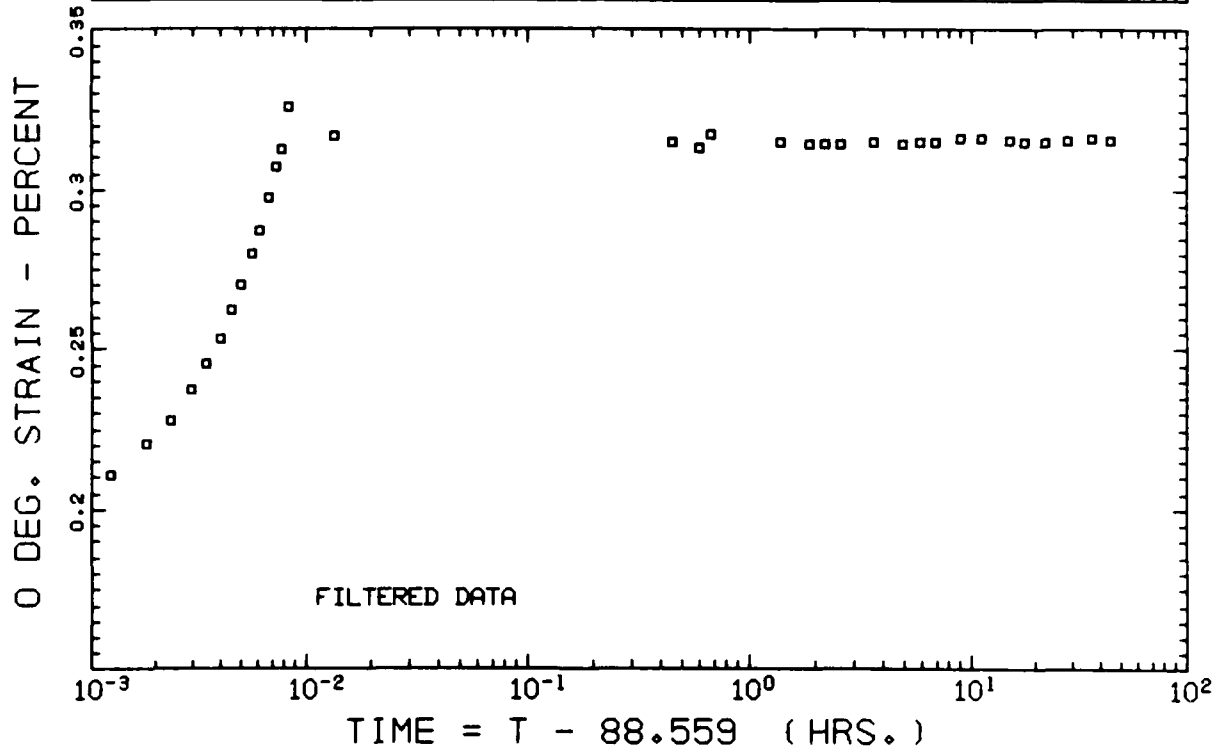
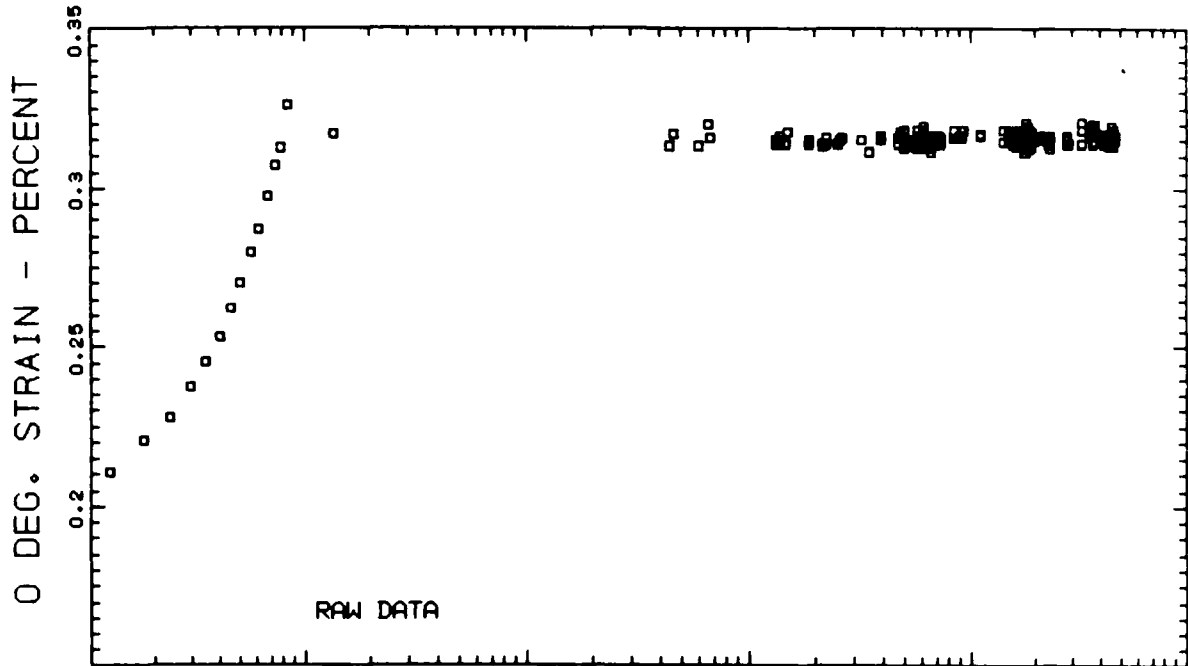

TIME = T - 88.559 (HRS.)

T300/5208 - STEP/RELAXATION - SPECIMEN No. 1 - STEP No. 3

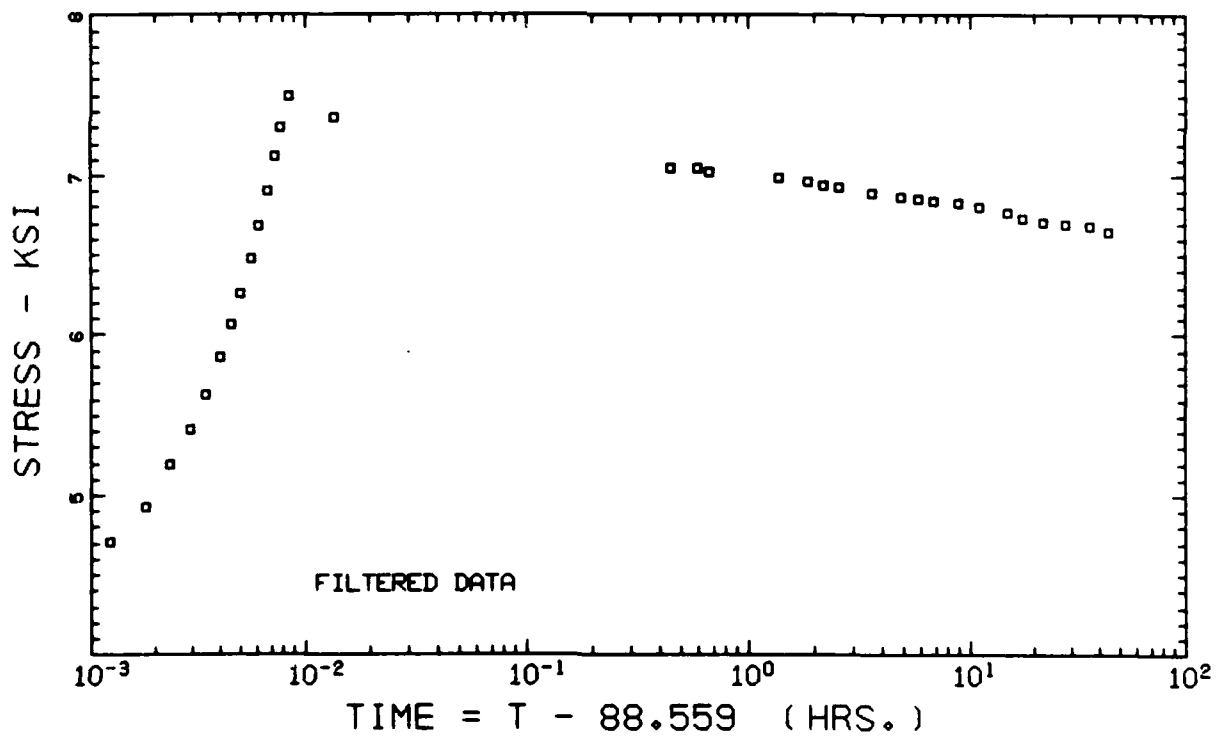
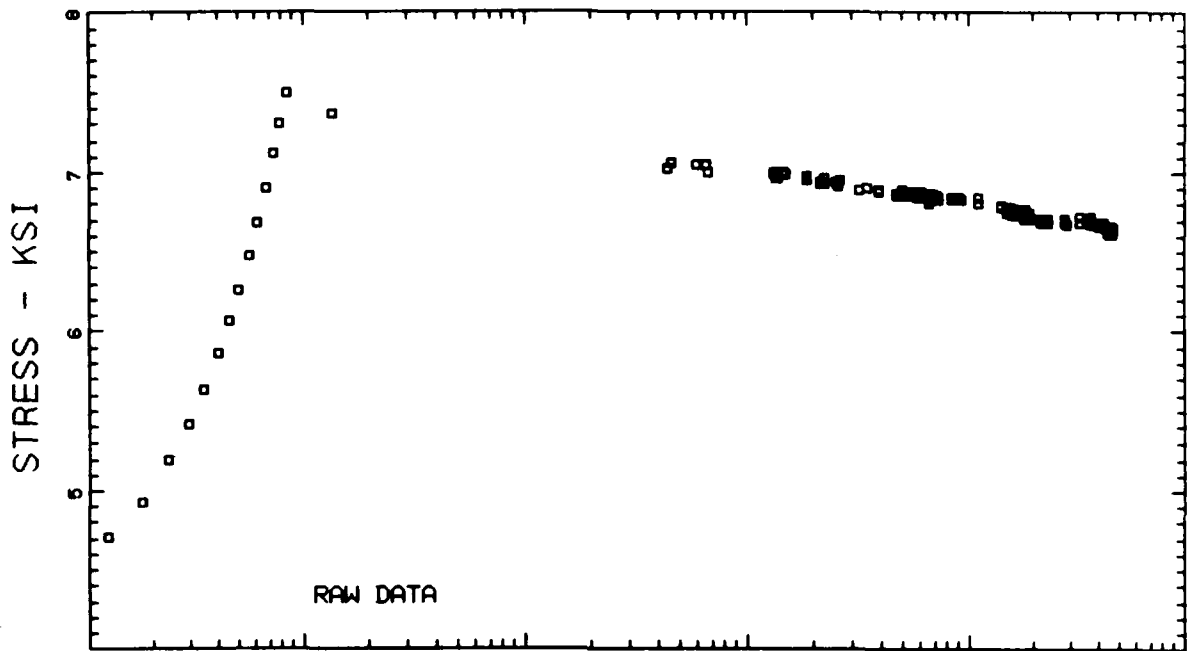



T300/5208 - STEP/RELAXATION - SPECIMEN No. 1 - STEP No. 3

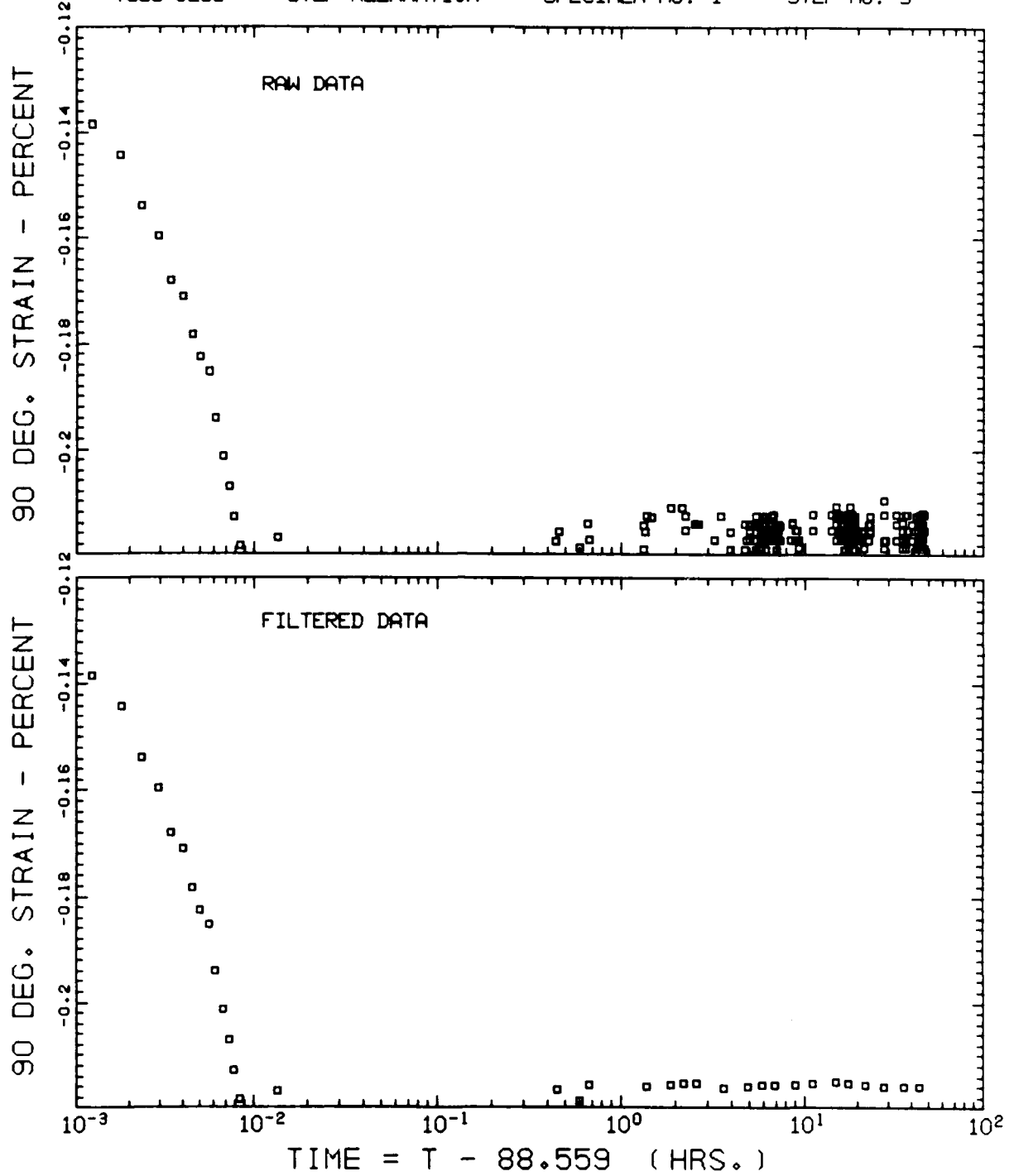

T300/5208 - STEP/RELAXATION - SPECIMEN No. 1 - STEP No. 4

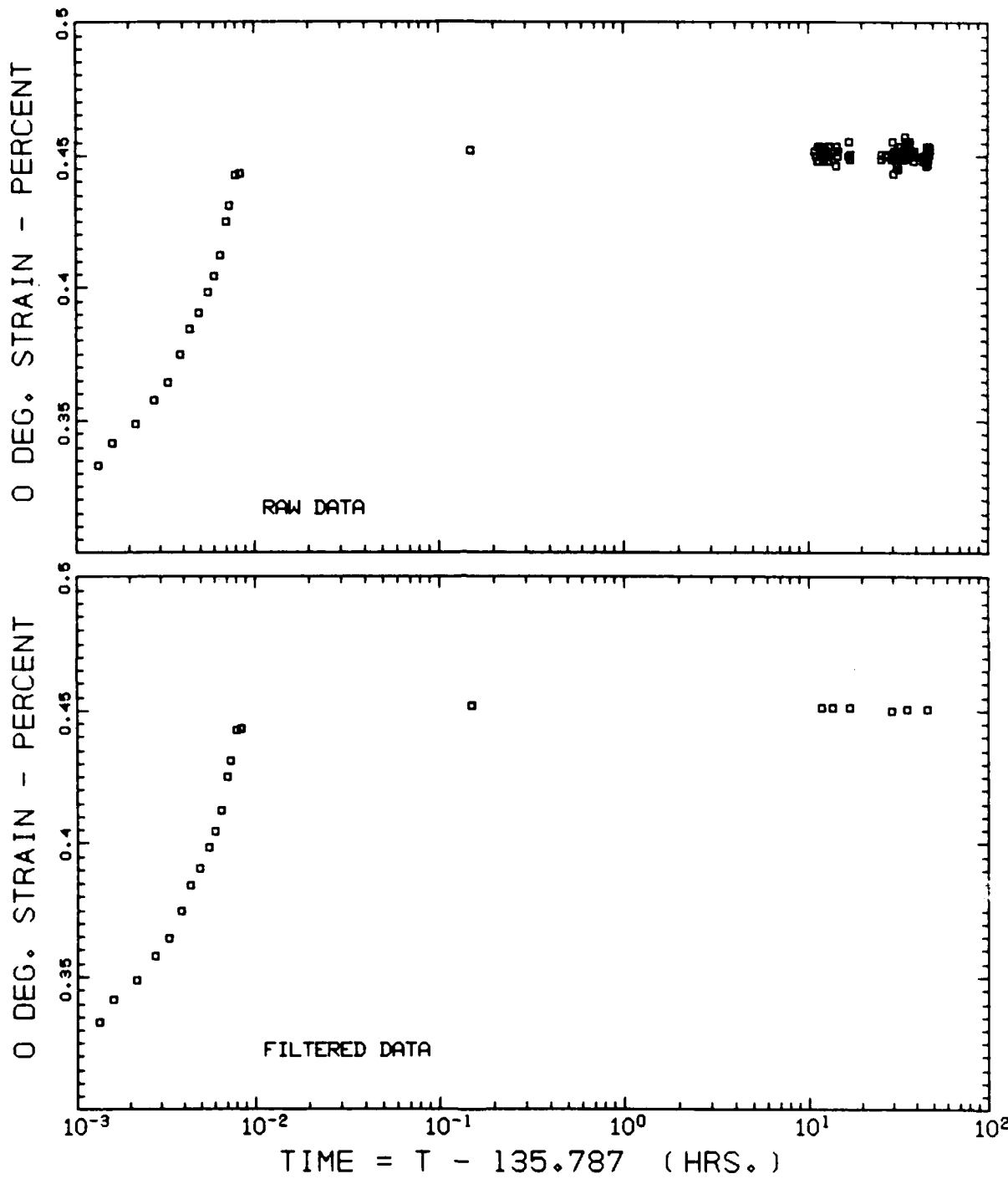

T300/5208 - STEP/RELAXATION - SPECIMEN No. 1 - STEP No. 4

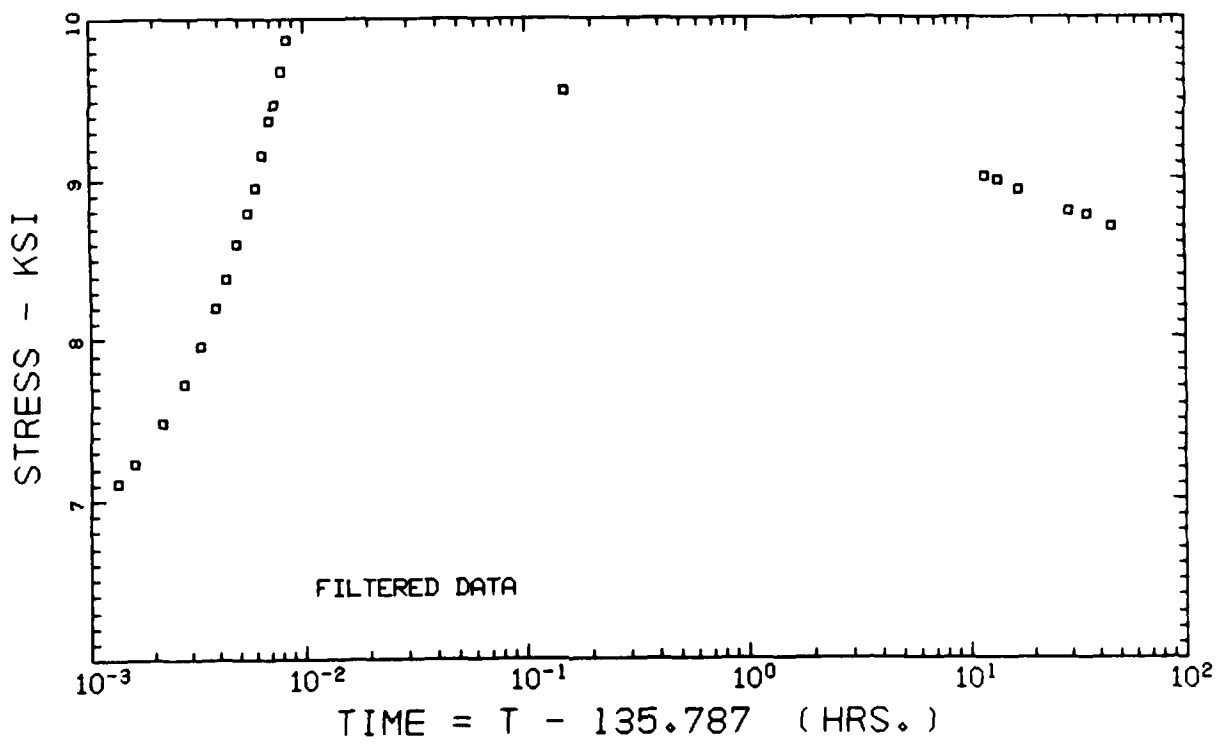
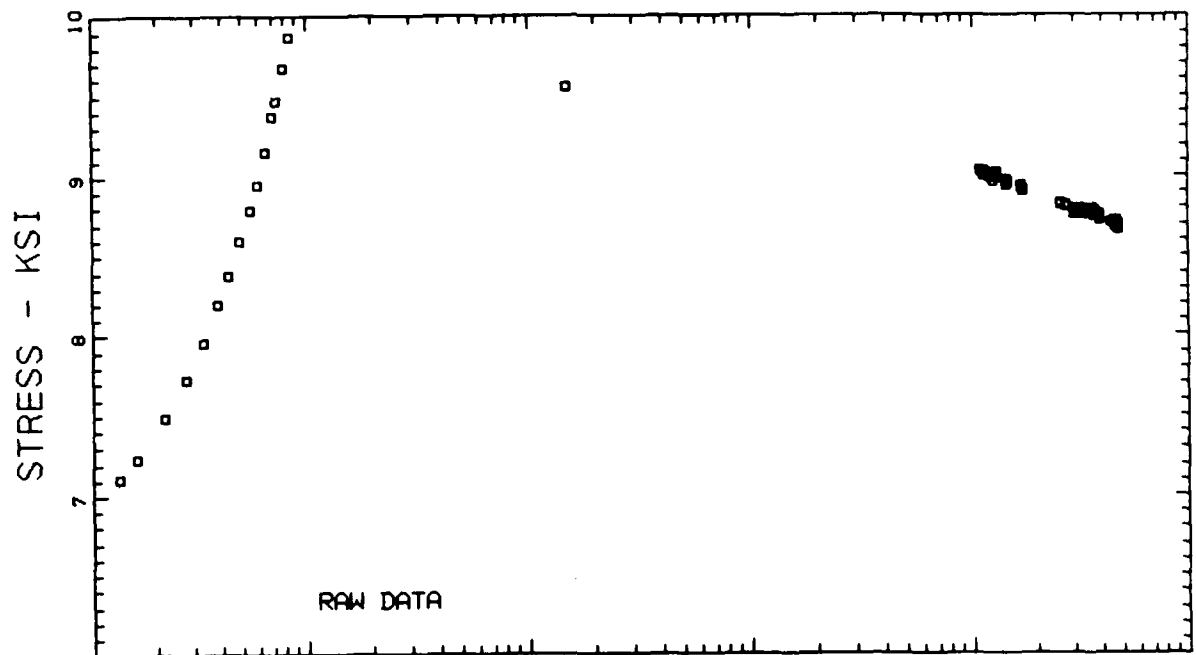

T300/5208 - STEP/RELAXATION - SPECIMEN No. 1 - STEP No. 4

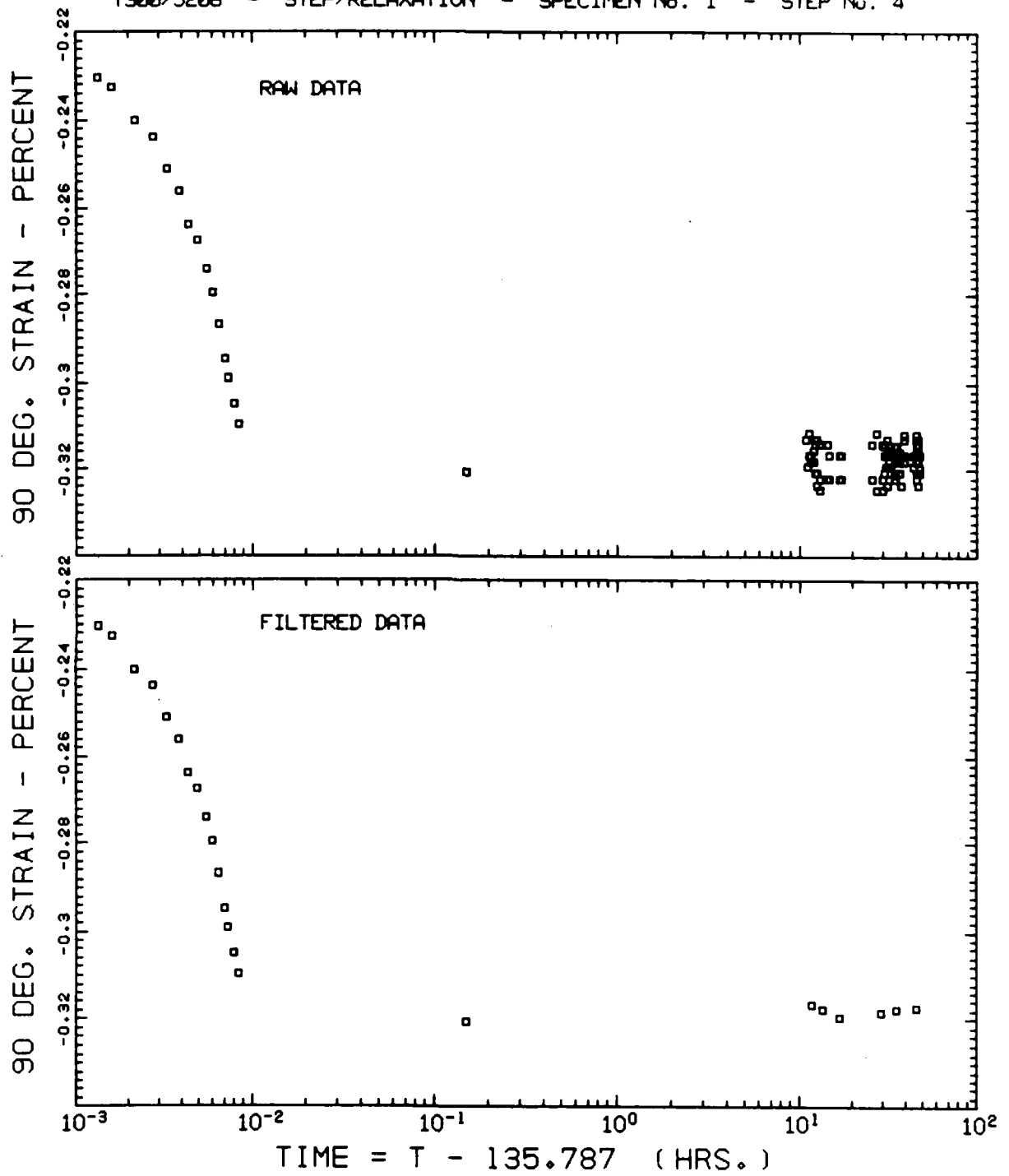

T300/5208 - STEP/RELAXATION - SPECIMEN No. 1 - STEP No. 5

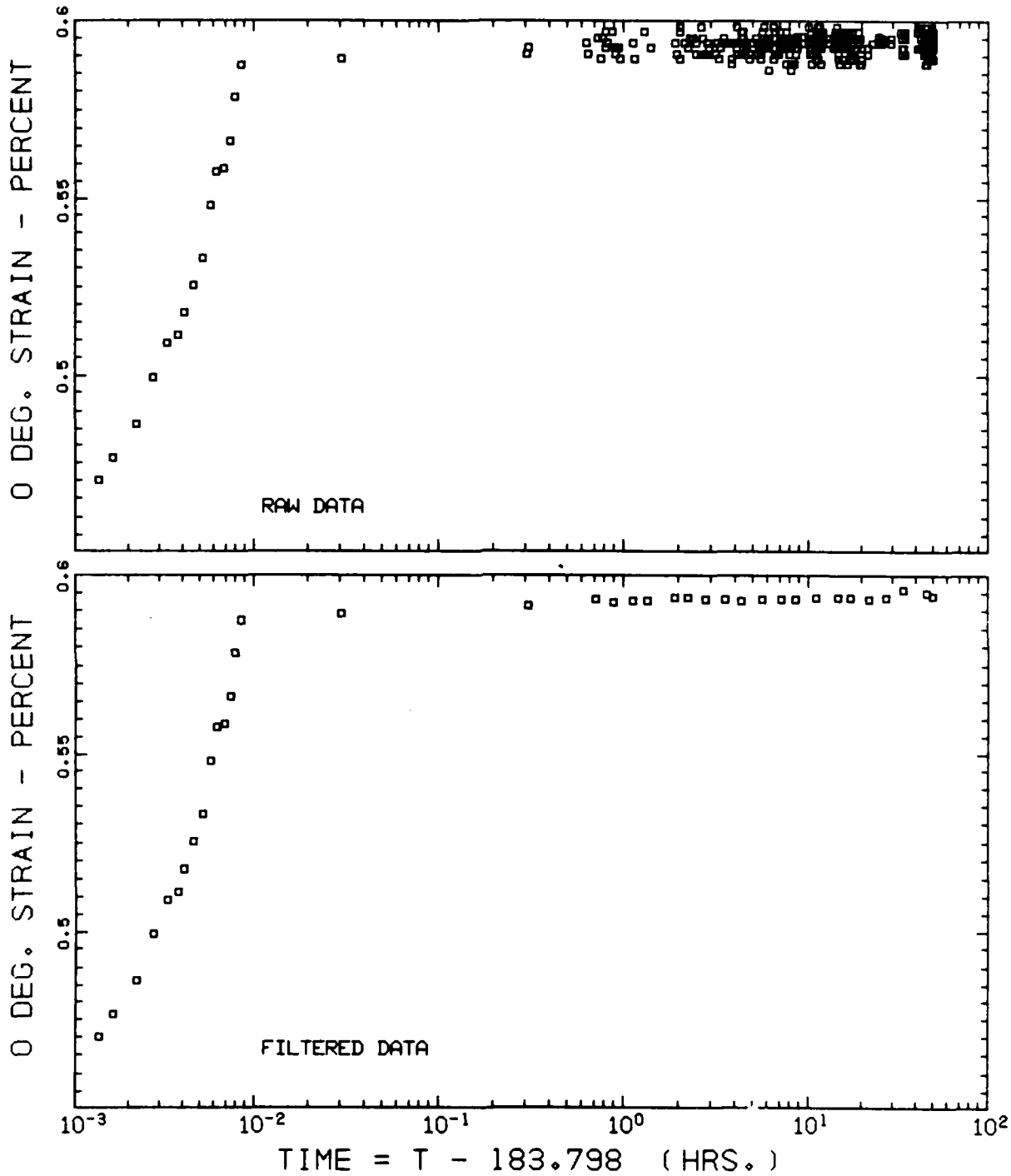

T300/5208 - STEP/RELAXATION - SPECIMEN No. 1 - STEP No. 5

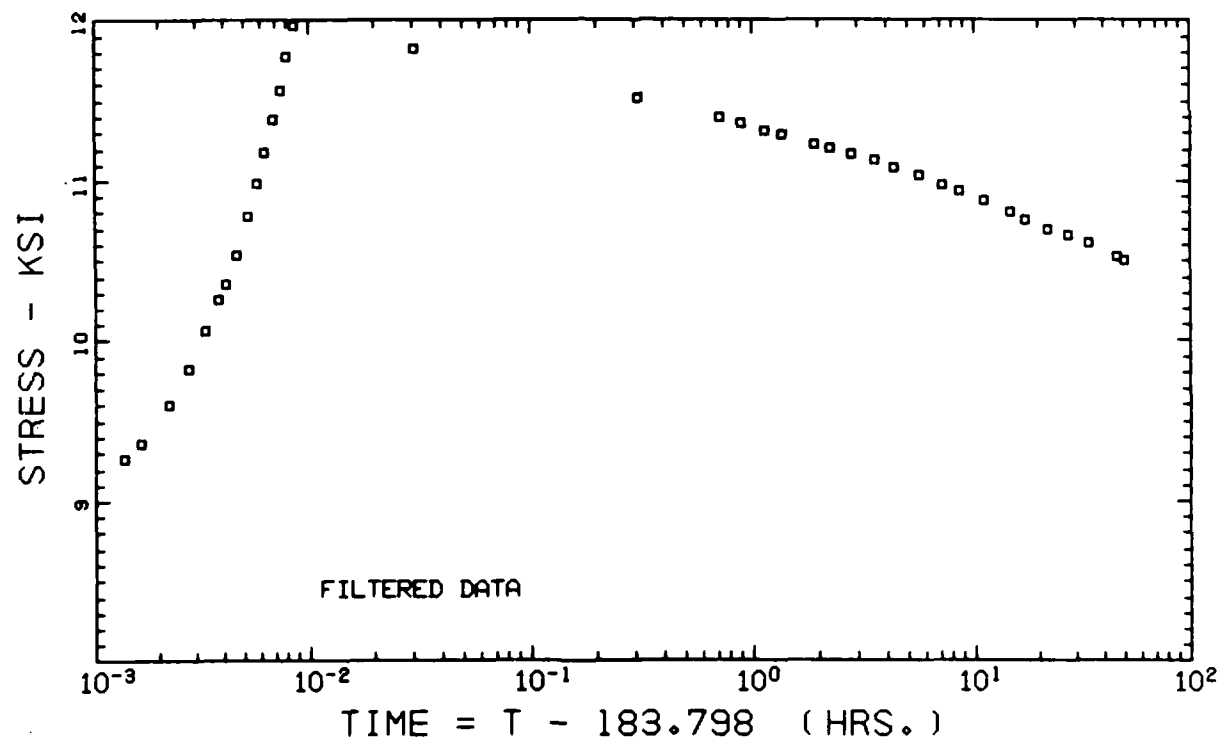
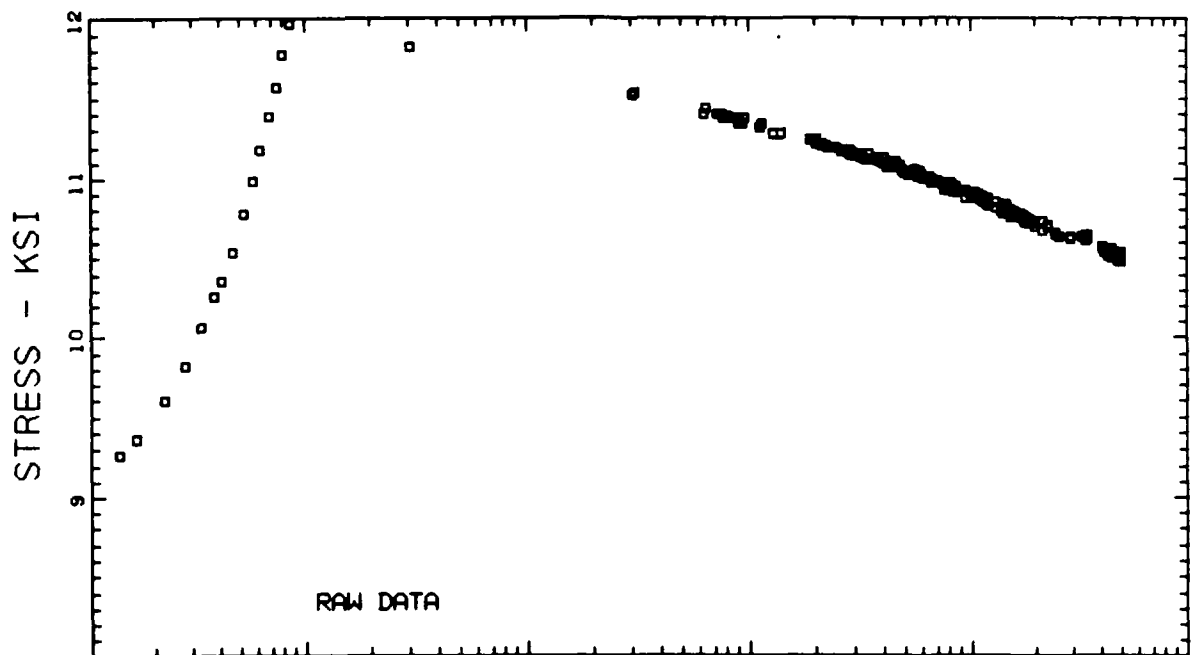

T300/5208 - STEP/RELAXATION - SPECIMEN No. 1 - STEP No. 5

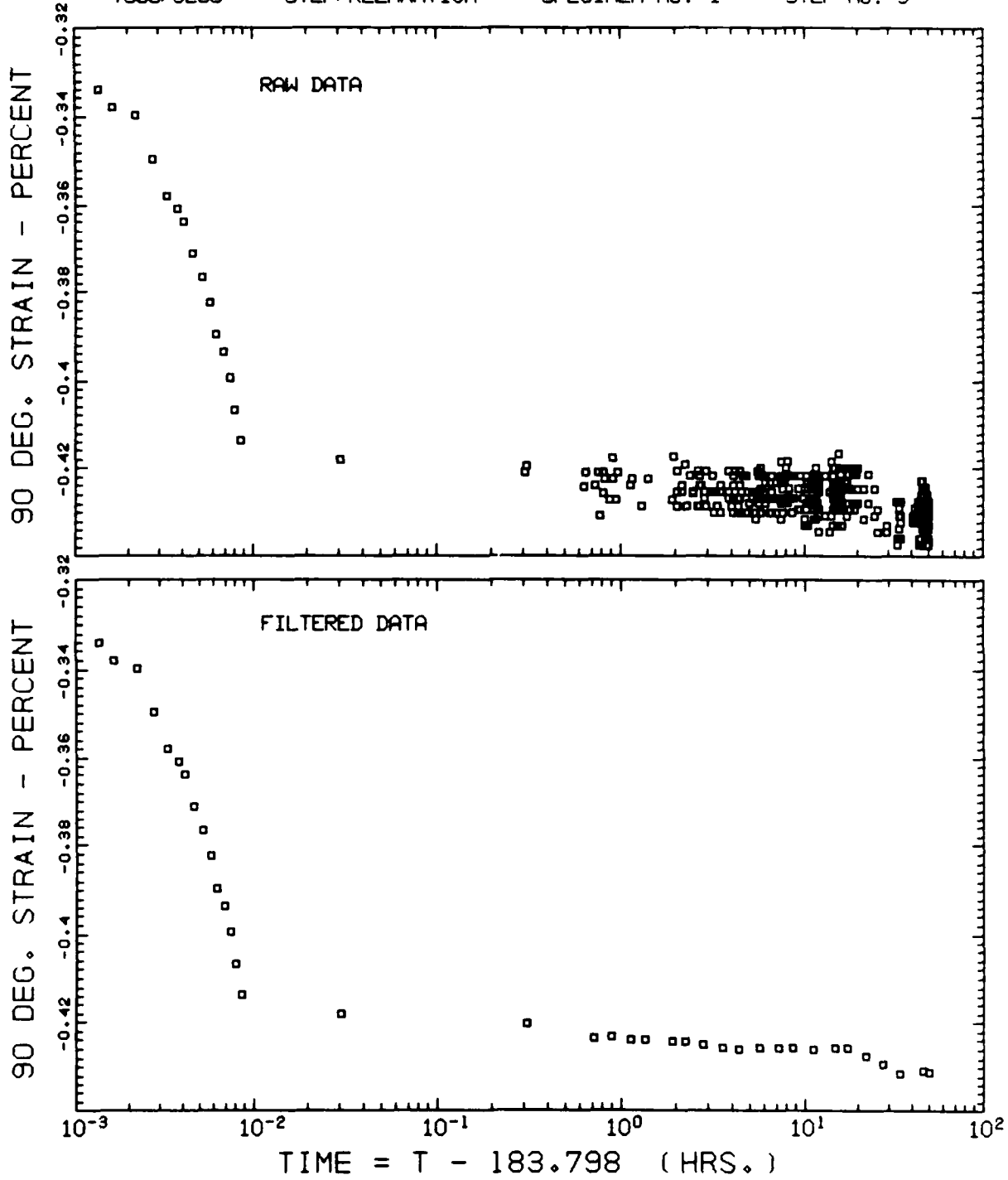

T300/5208 - STEP/RELAXATION - SPECIMEN No. 1 - STEP No. 6

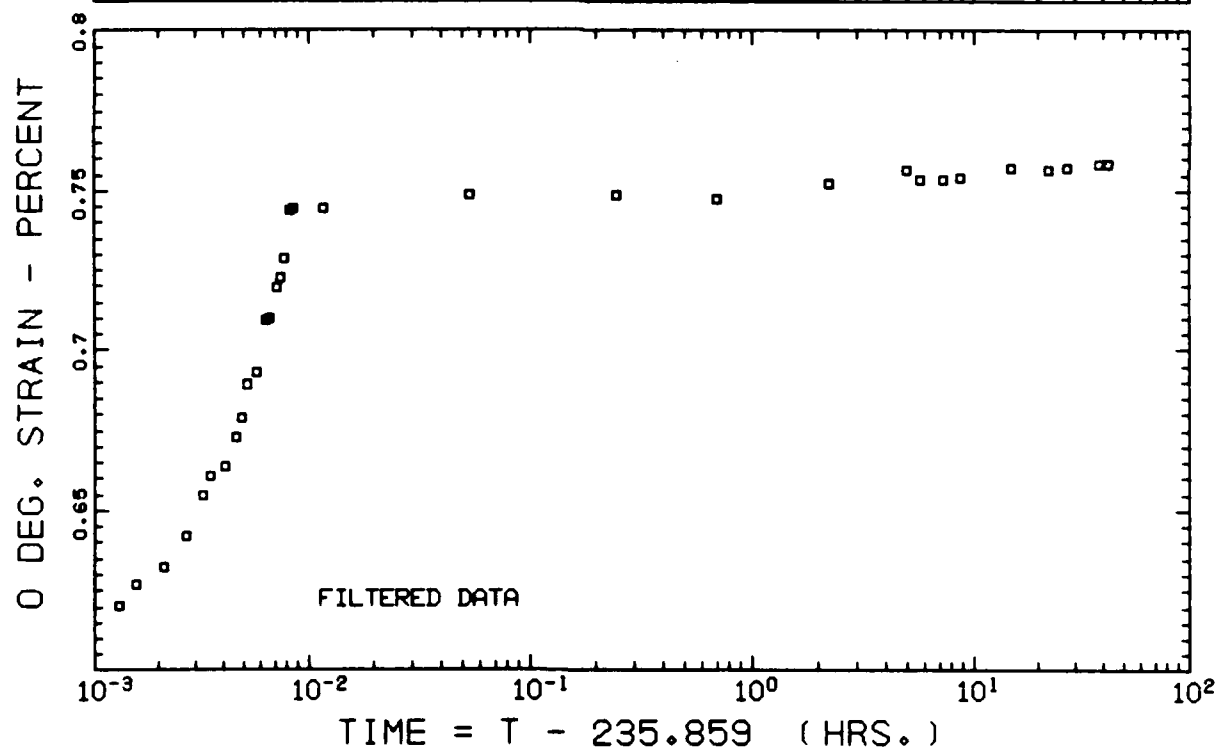
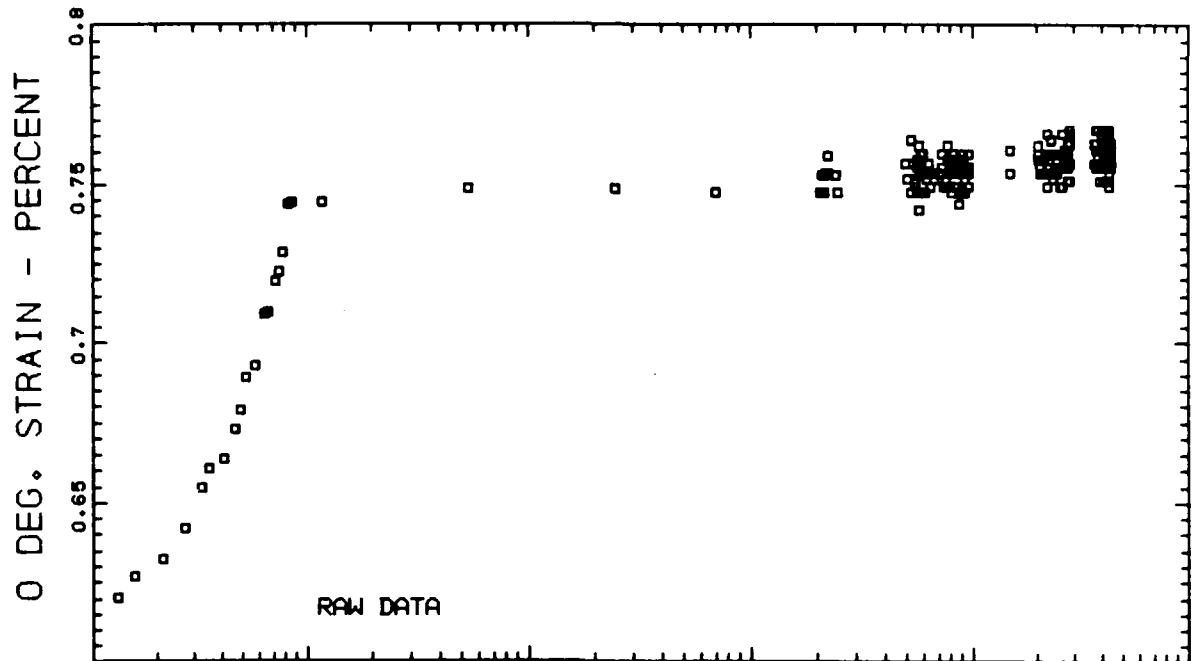



T300/S208 - STEP/RELAXATION - SPECIMEN No. 1 - STEP No. 6

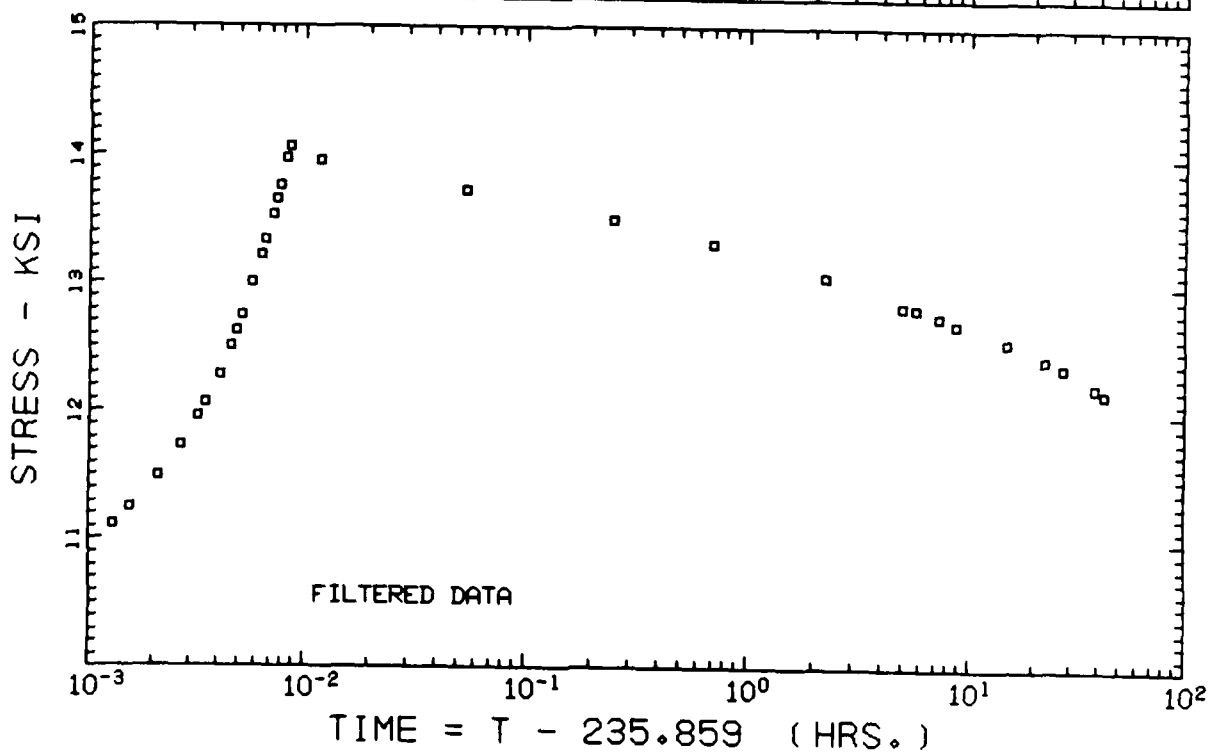
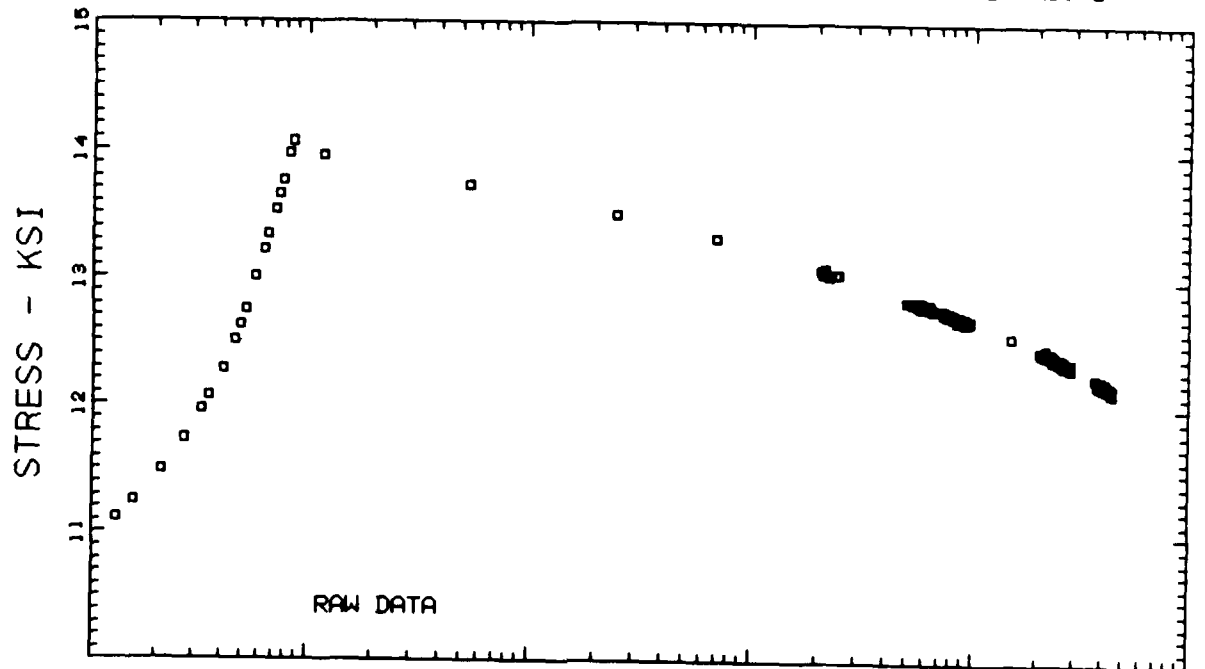

T300/5208 - STEP/RELAXATION - SPECIMEN No. 3 - STEP No. 6

90 DEG. STRAIN - PERCENT

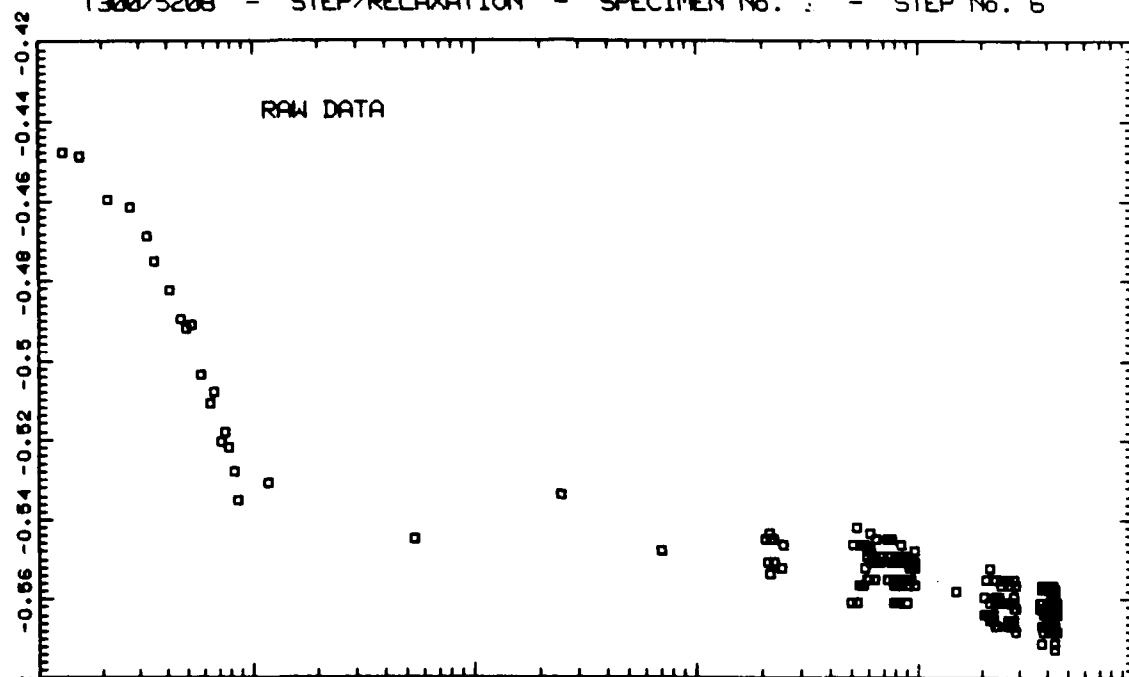

90 DEG. STRAIN - PERCENT

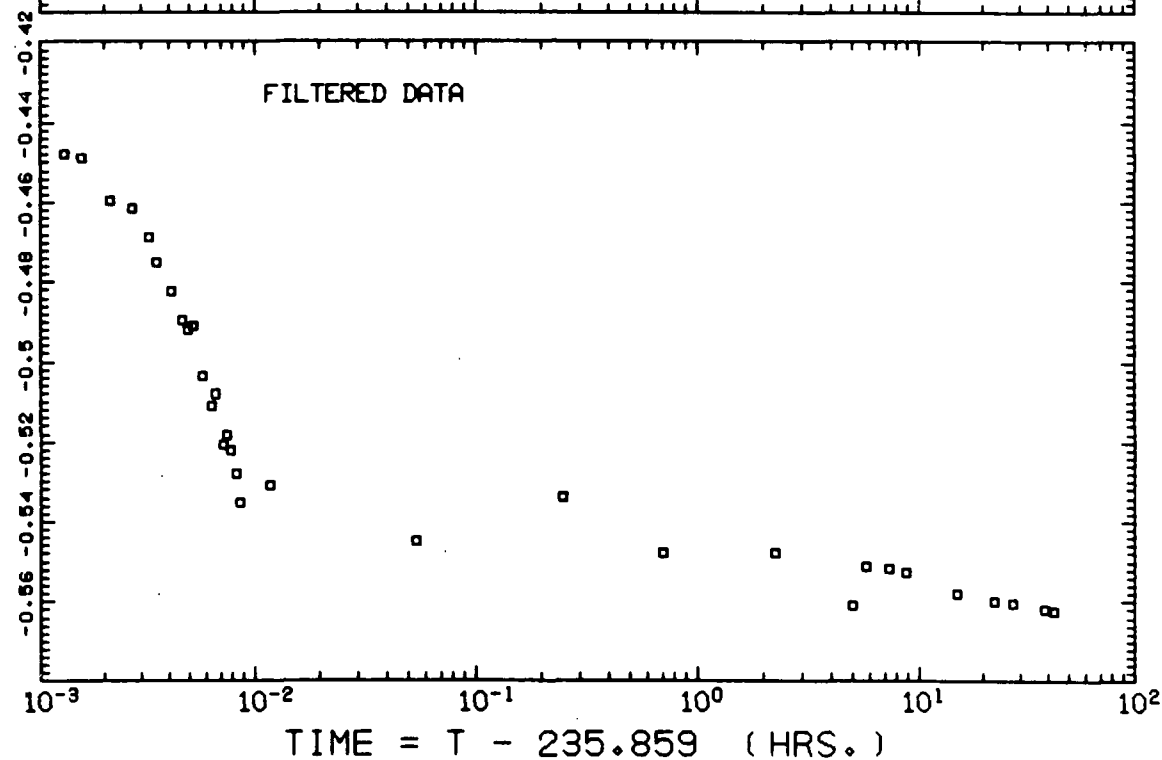

T300/5208 - STEP/RELAXATION - SPECIMEN No. 1 - STEP No. 7

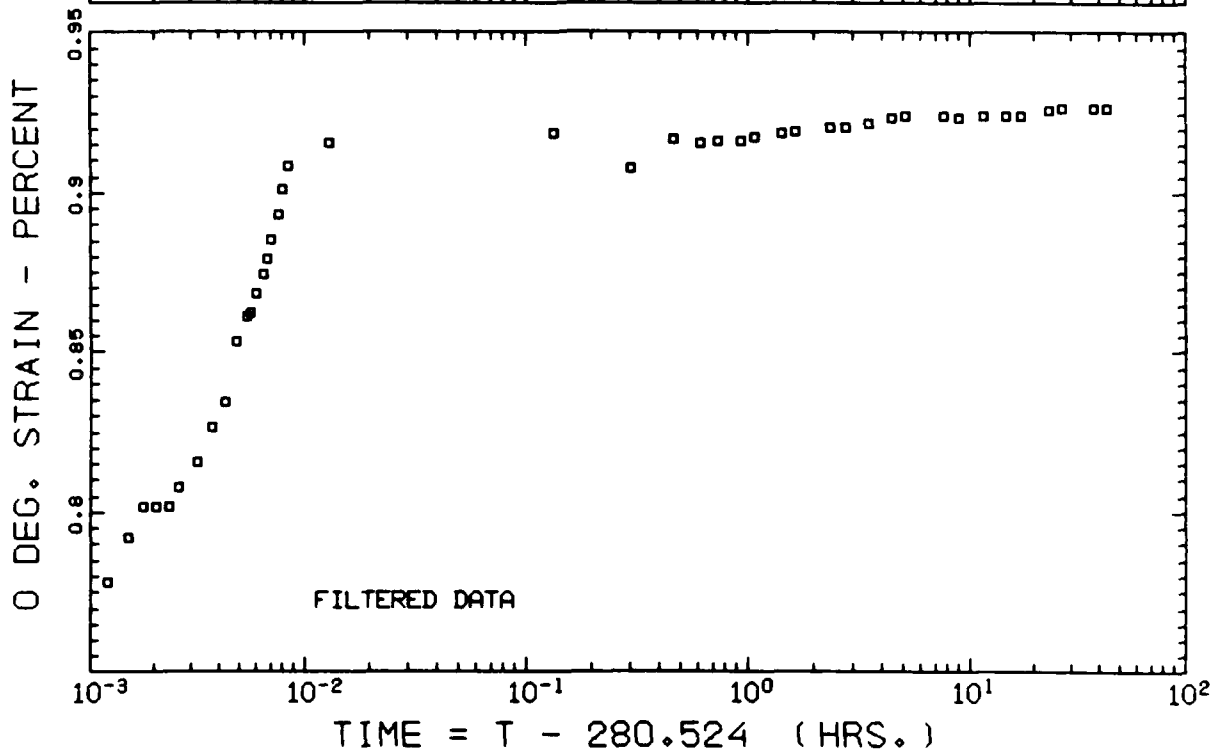
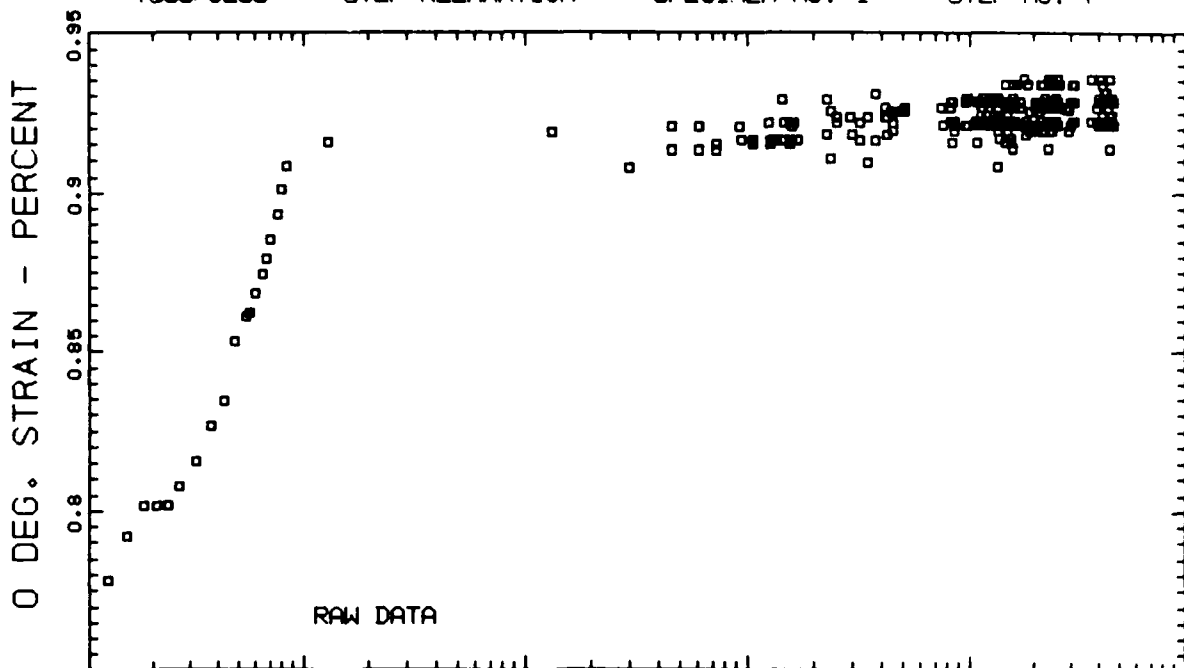

T300/5208 - STEP/RELAXATION - SPECIMEN No. 1 - STEP No. 7

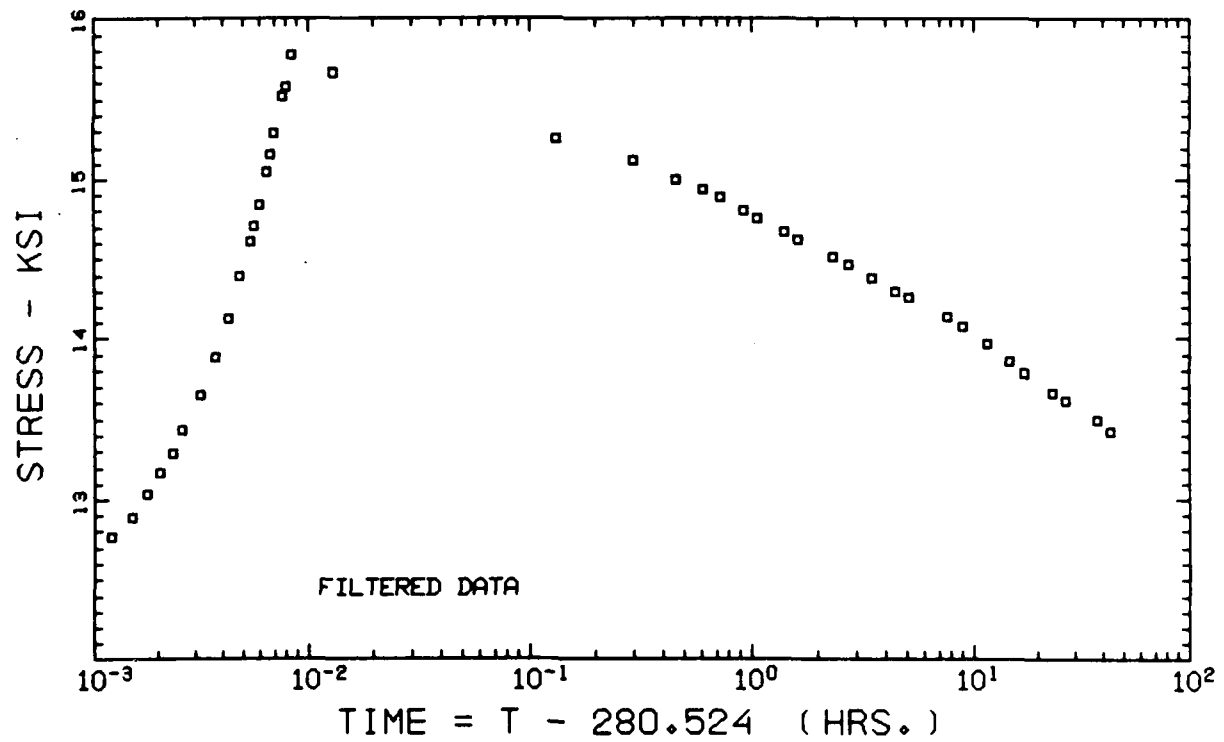
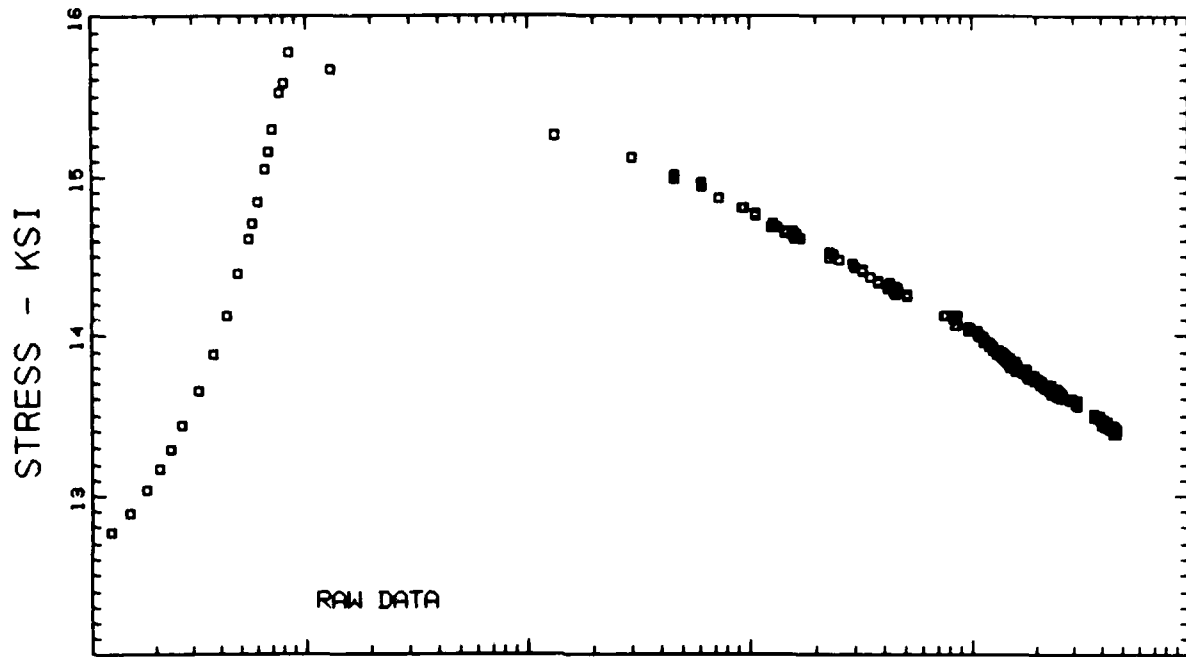

T300/5208 - STEP/RELAXATION - SPECIMEN No. 1 - STEP No. 7

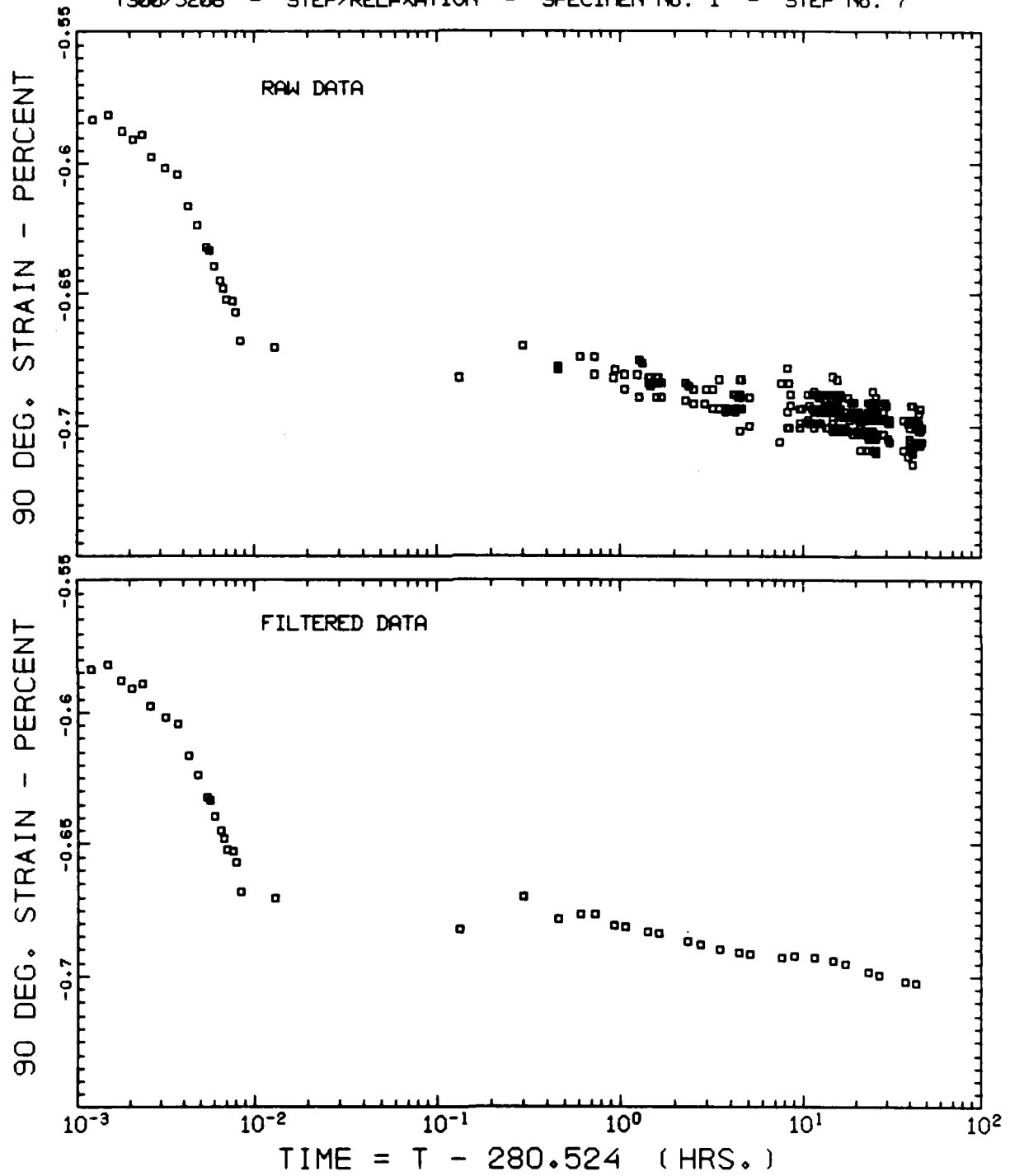

T300/5208 - STEP/RELAXATION - SPECIMEN No. 1 - STEP No. 8

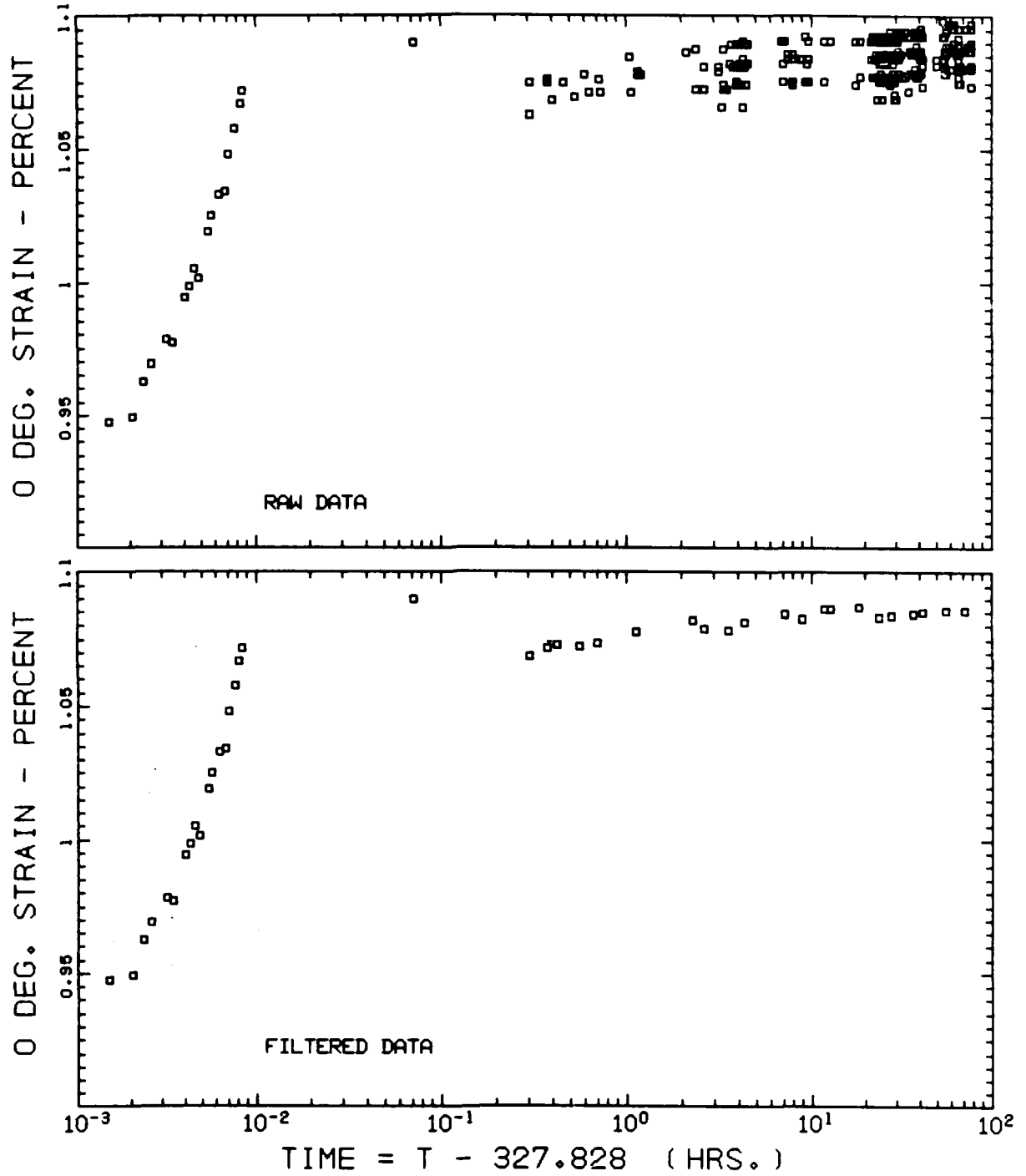

T300/5248 - STEP/RELAXATION - SPECIMEN No. 1 - STEP No. 8

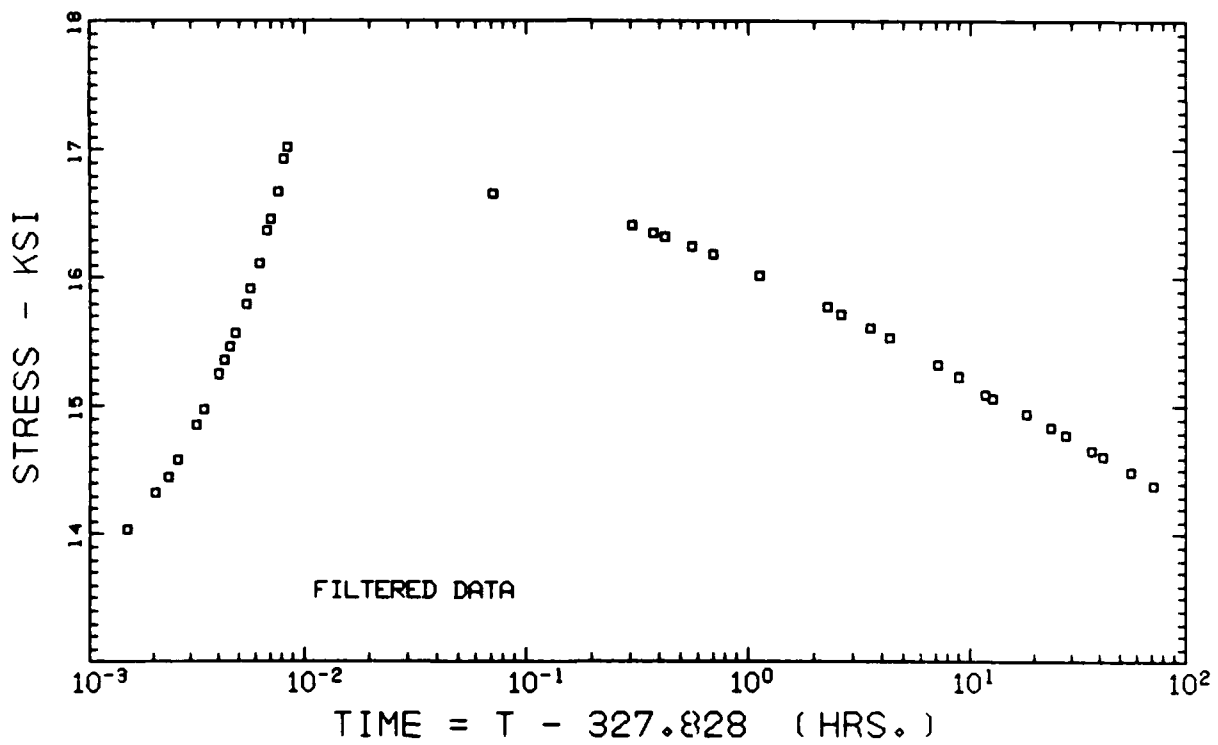
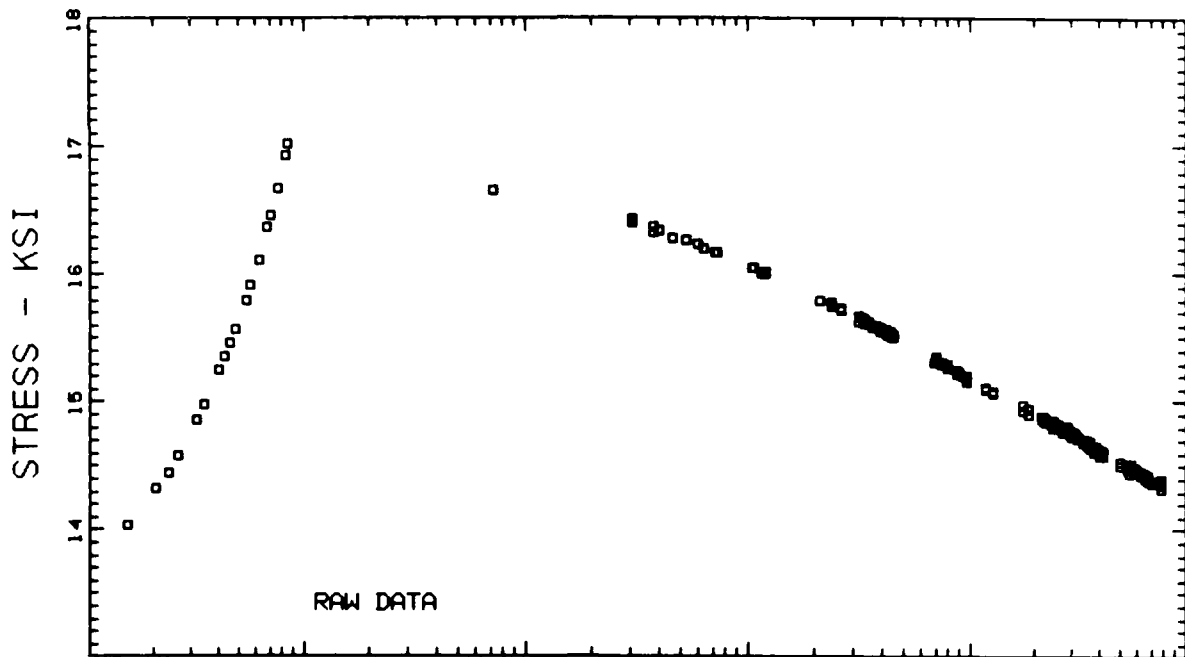

T300/5208 - STEP/RELAXATION - SPECIMEN No. 1 - STEP No. 8

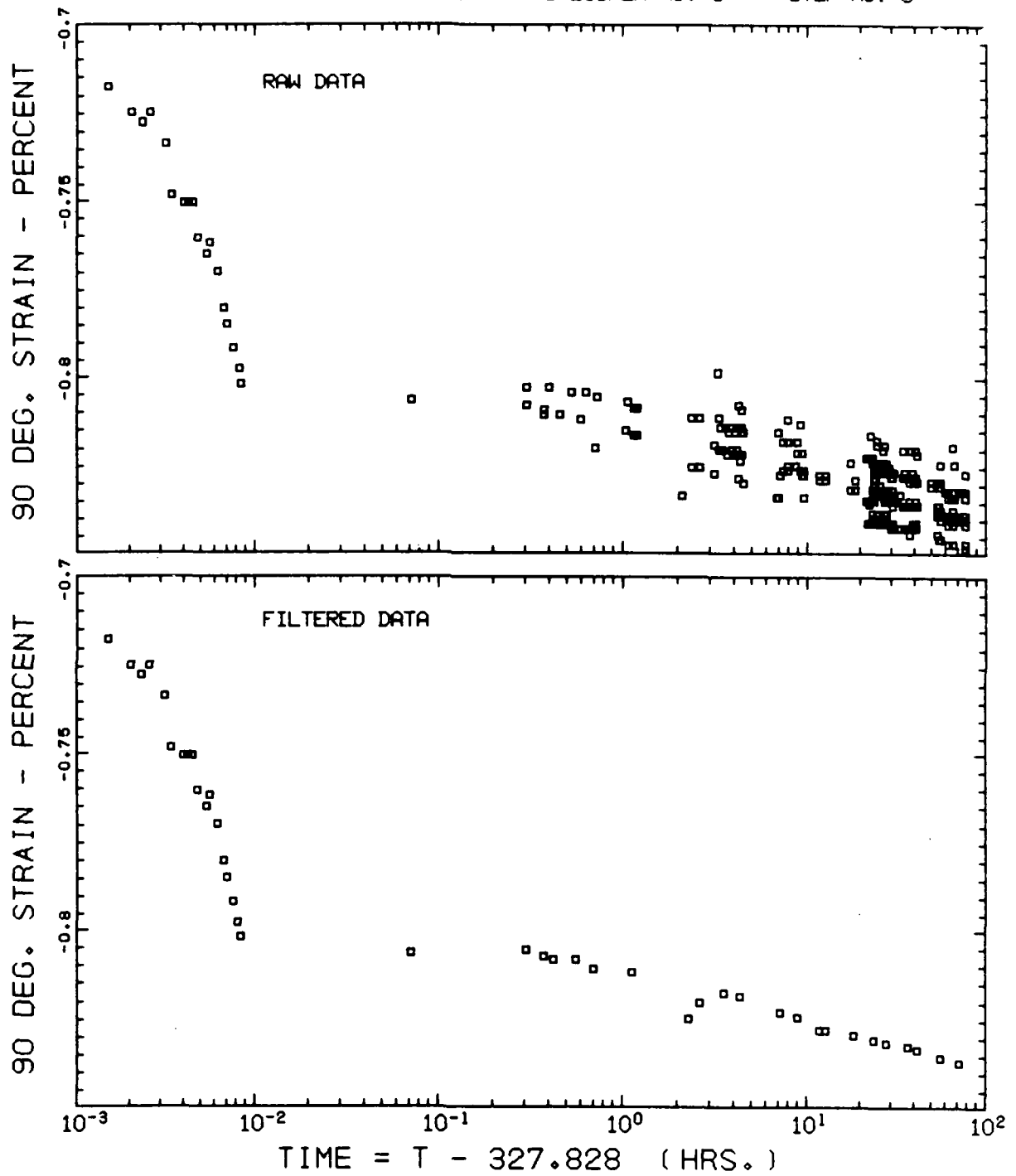



1000/5208 - STEP/RELAXATION - SPECIMEN No. 1 - STEP No. 9

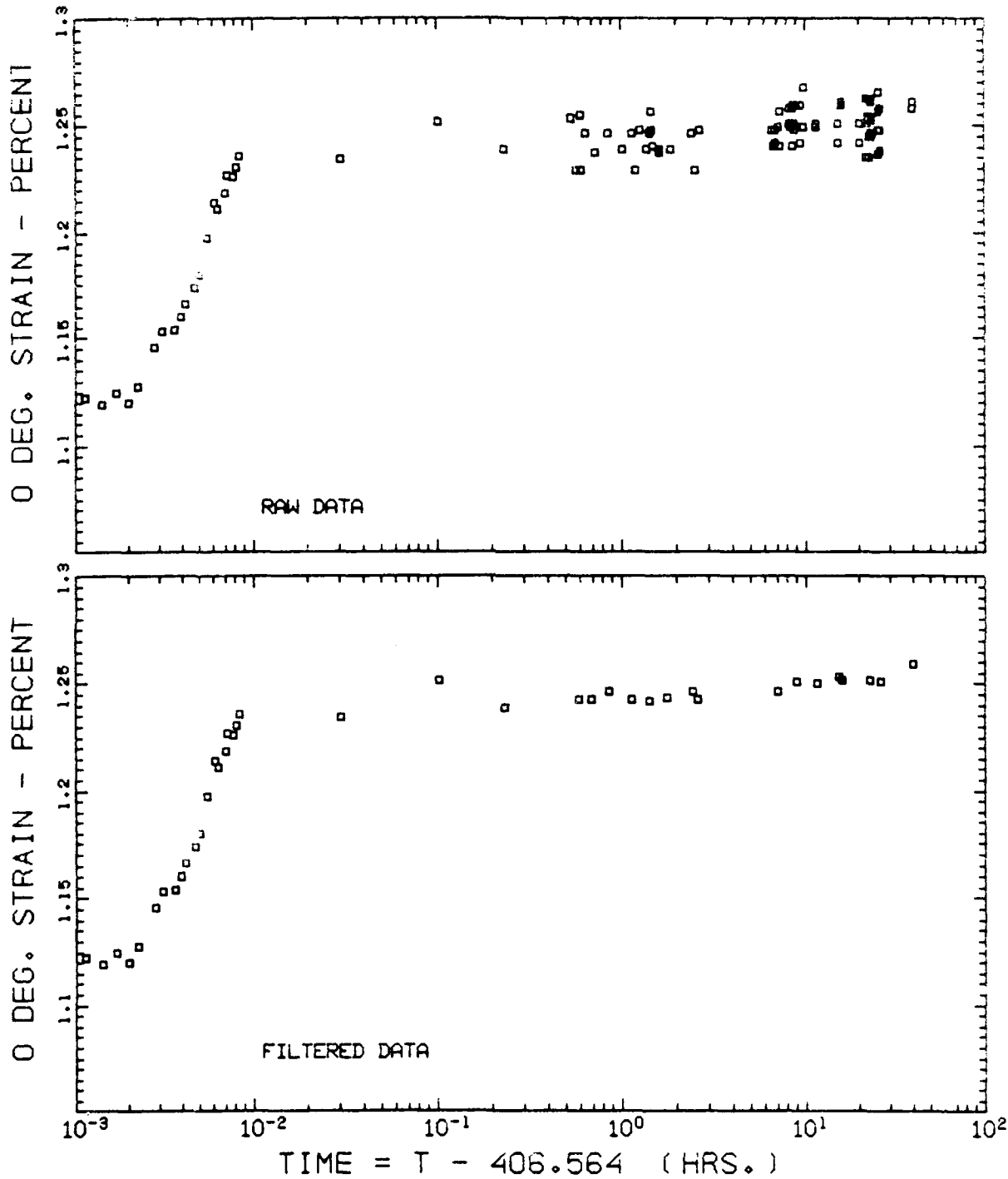

T300/5208 - STEP/RELAXATION - SPECIMEN No. 1 - STEP No. 9

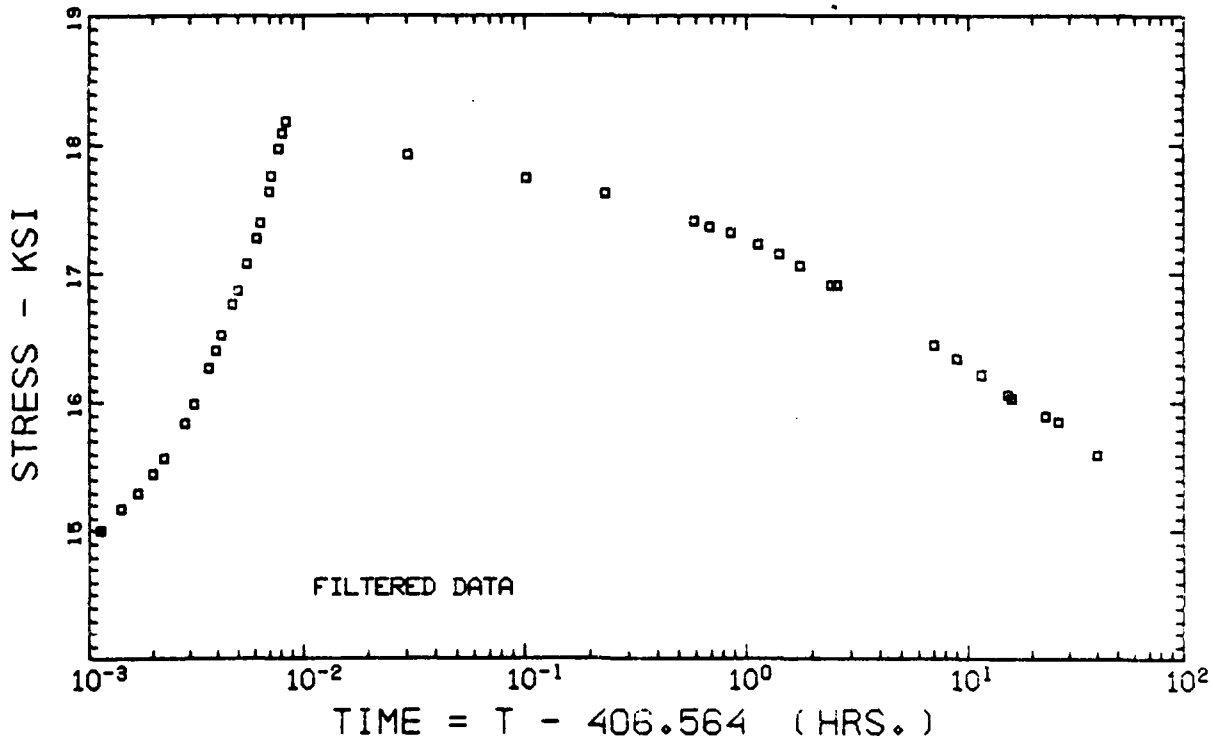
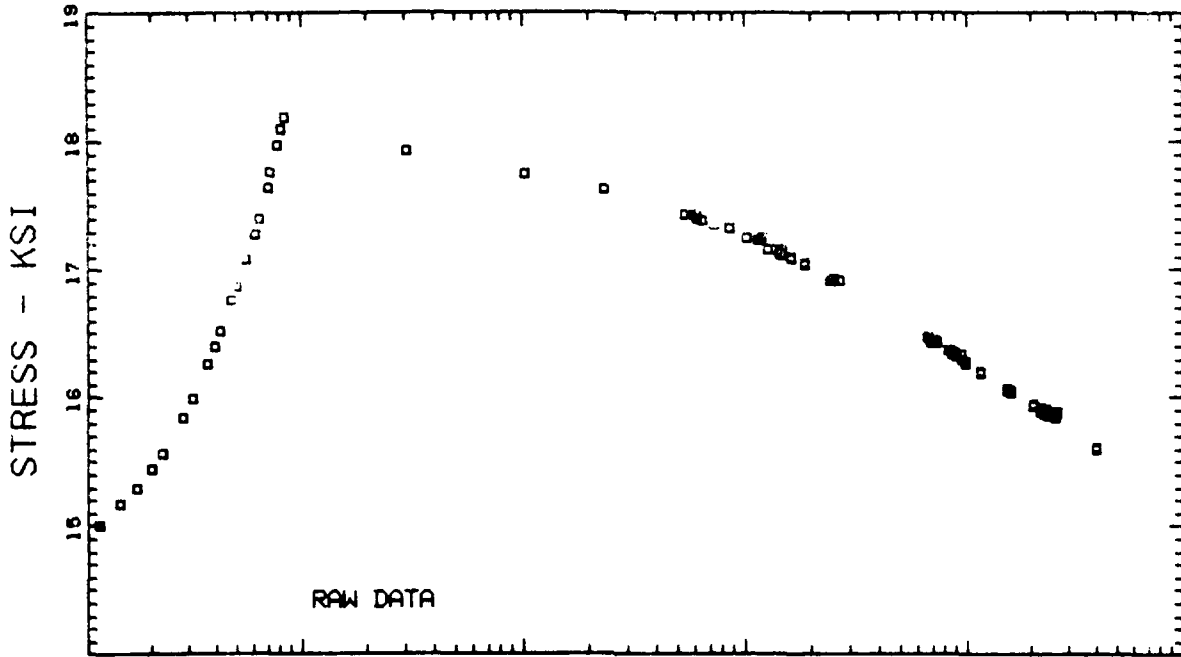

T300/5208 - STEP/RELAXATION - SPECIMEN No. 1 - STEP No. 9

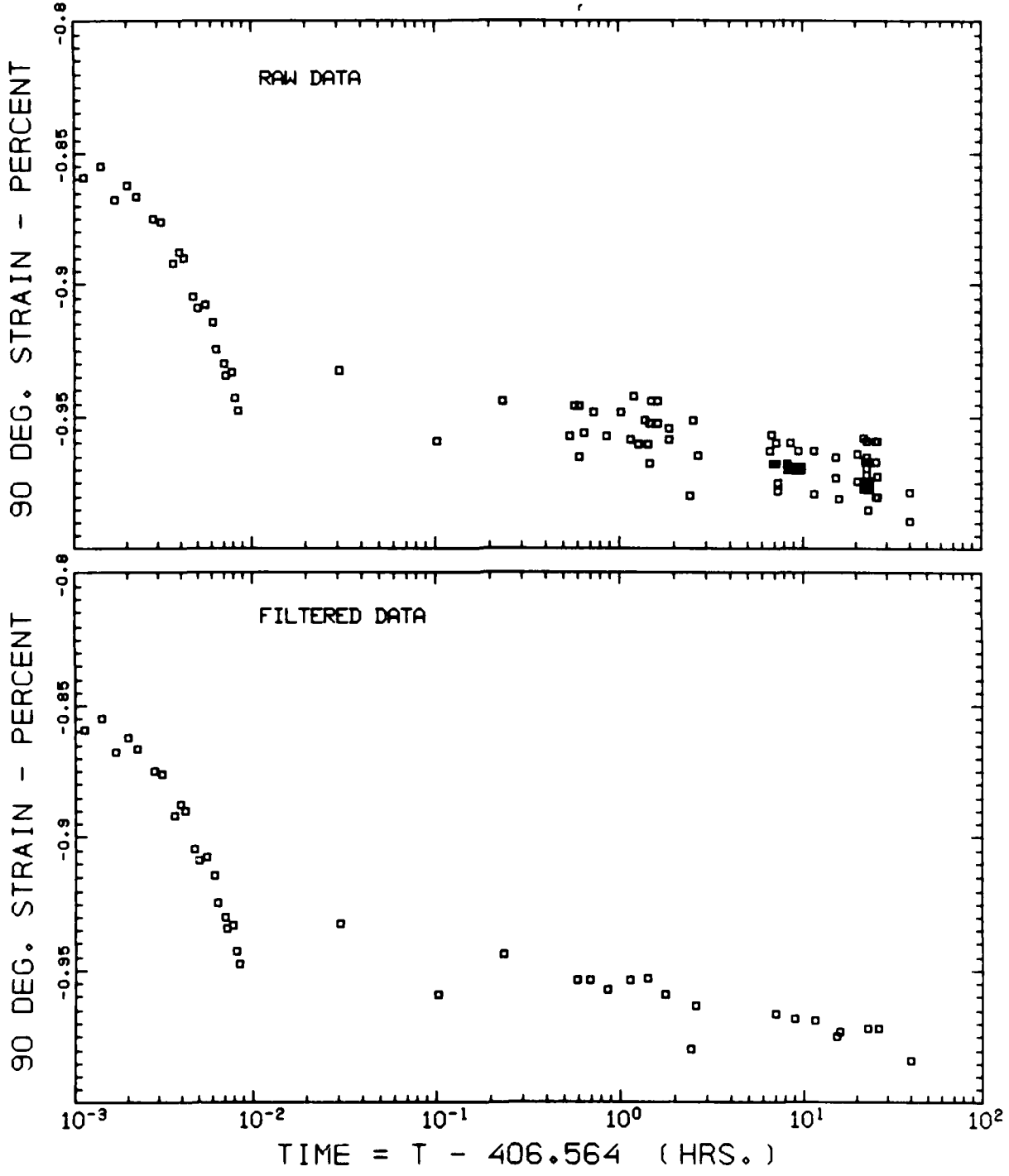

T300/5208 - STEP/RELAXATION - SPECIMEN NO. 2

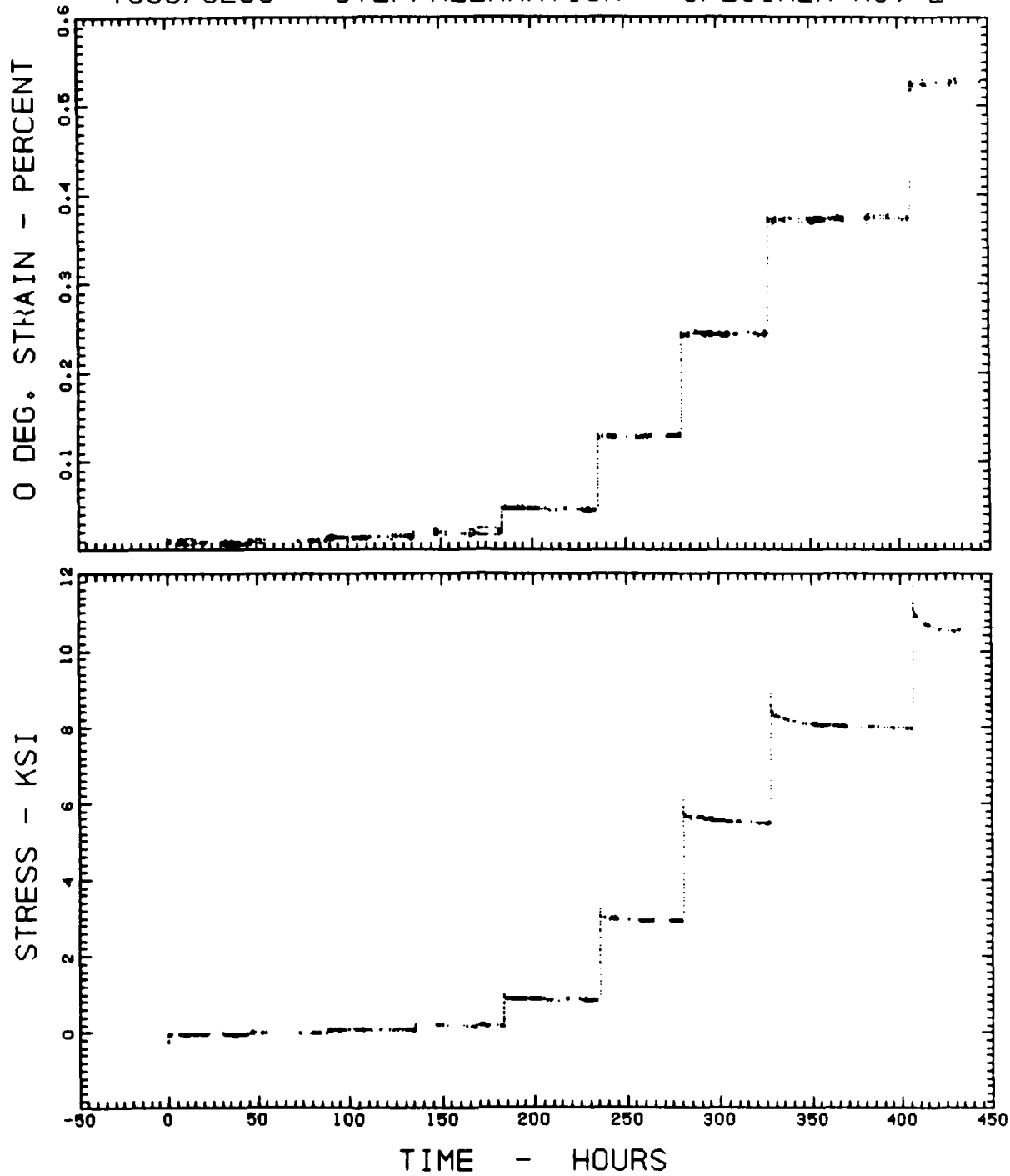

T300/5208 - STEP/RELAXATION - SPECIMEN NO. 2

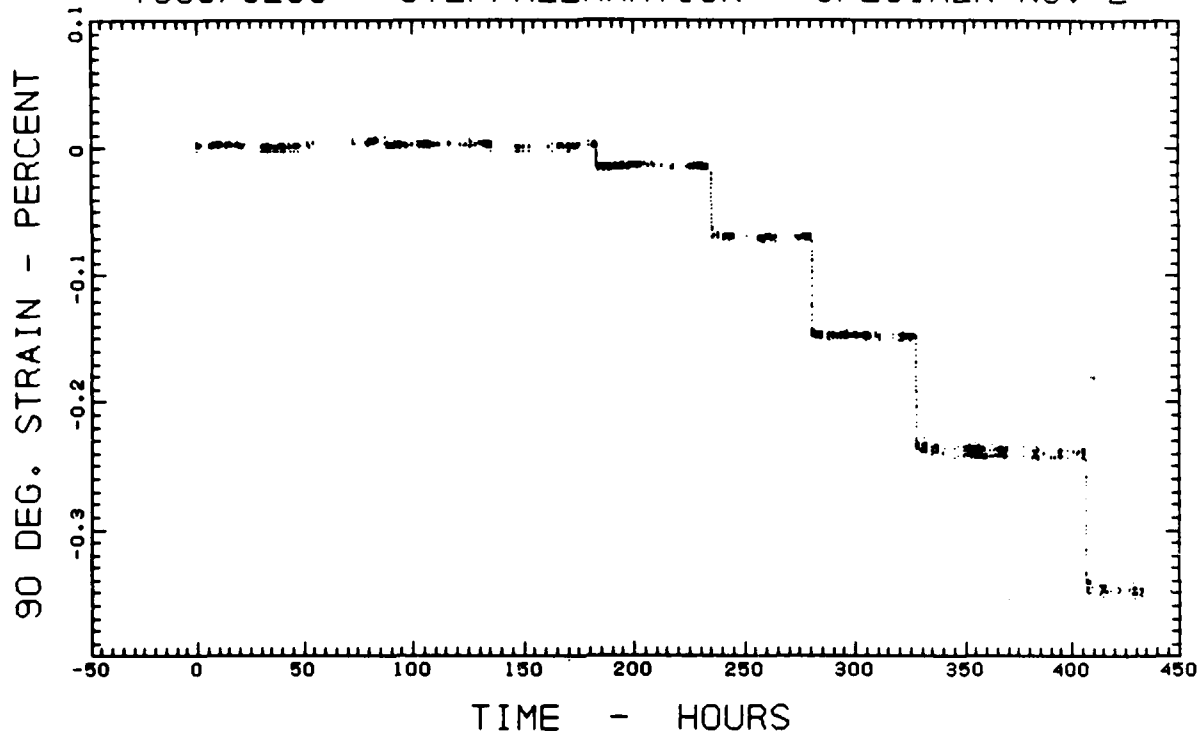

T300/5208 - STEP/RELAXATION - SPECIMEN No. 2 - STEP No. 5

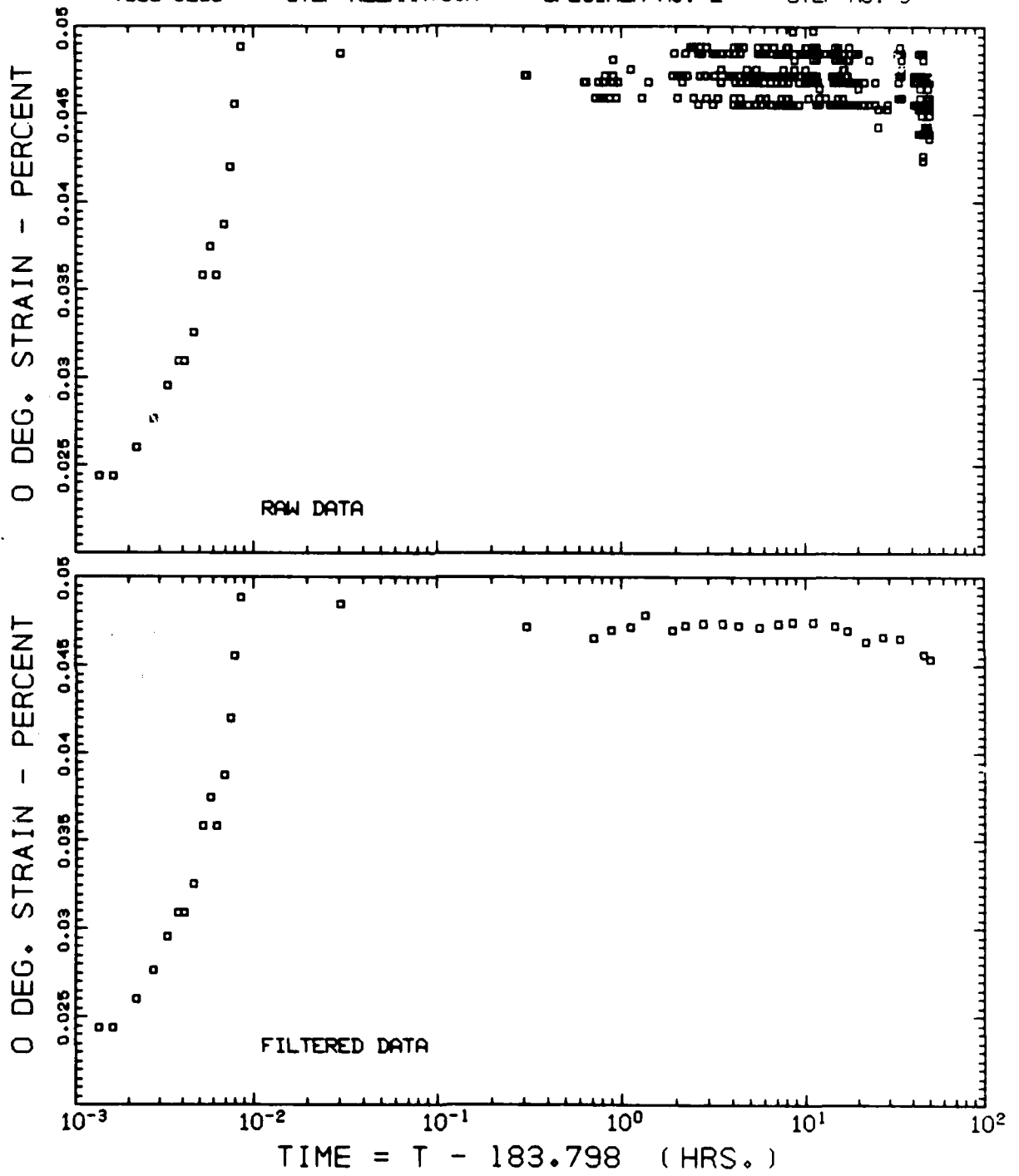

T300/5208 - STEP/RELAXATION - SPECIMEN No. 2 - STEP No. 5

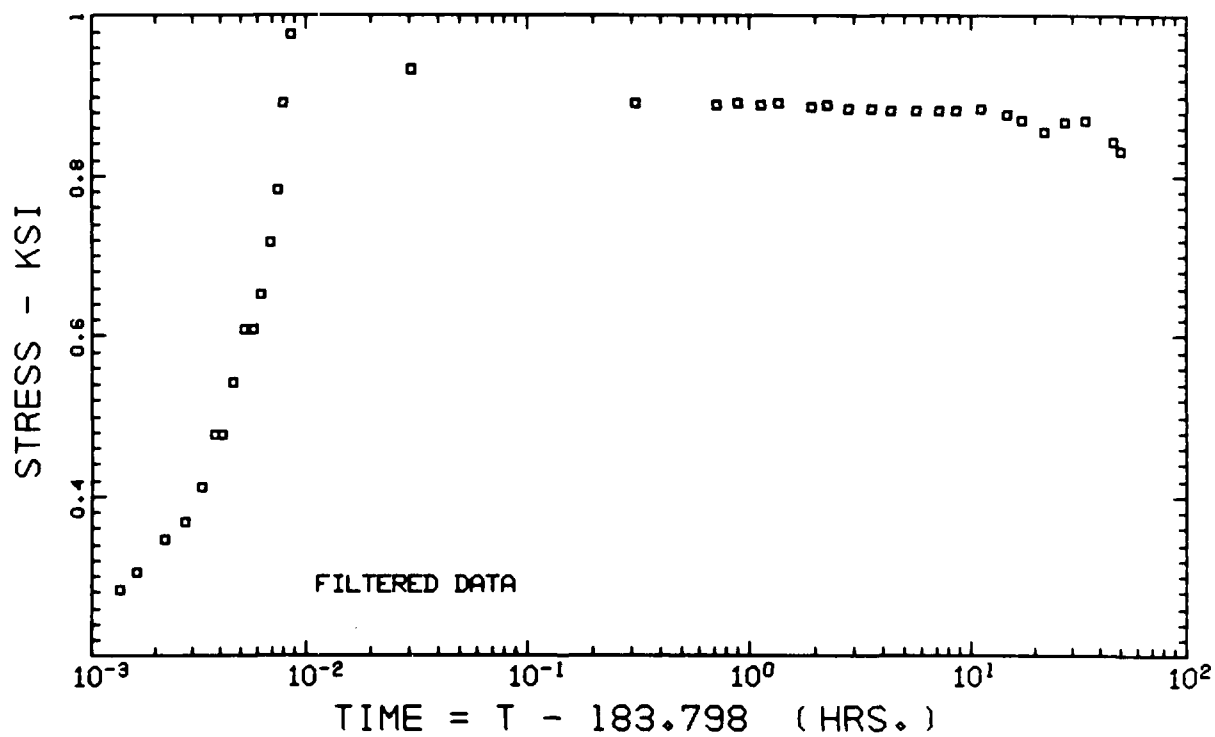
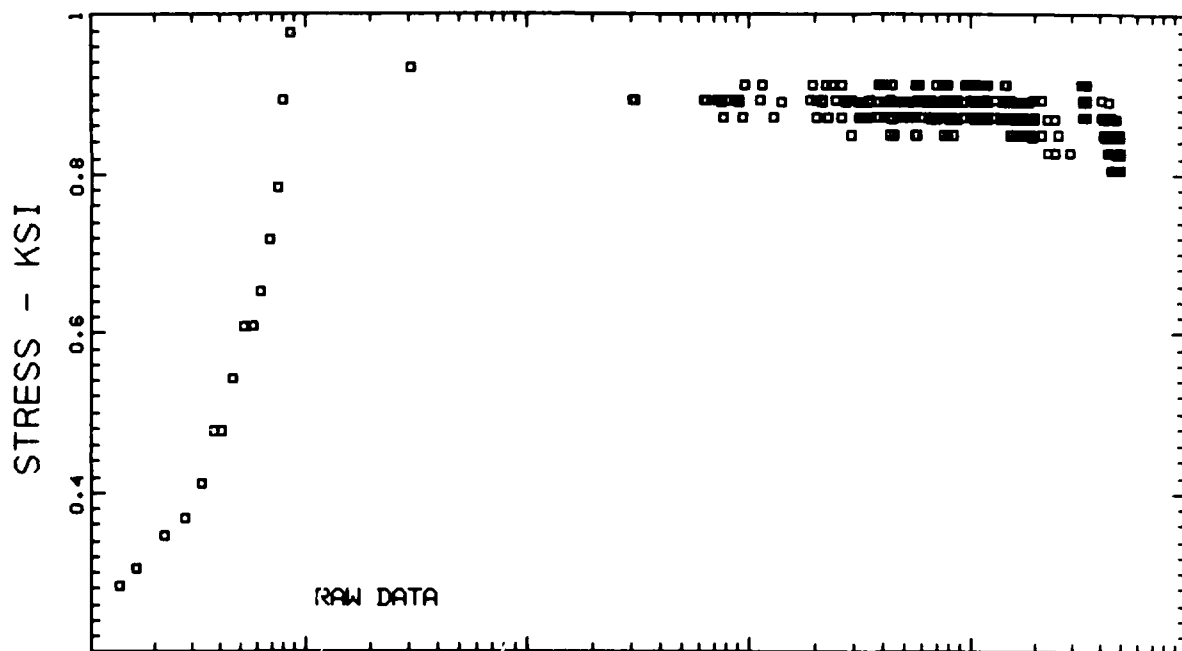

T300/5208 - STEP/RELAXATION - SPECIMEN No. 2 - STEP No. 5

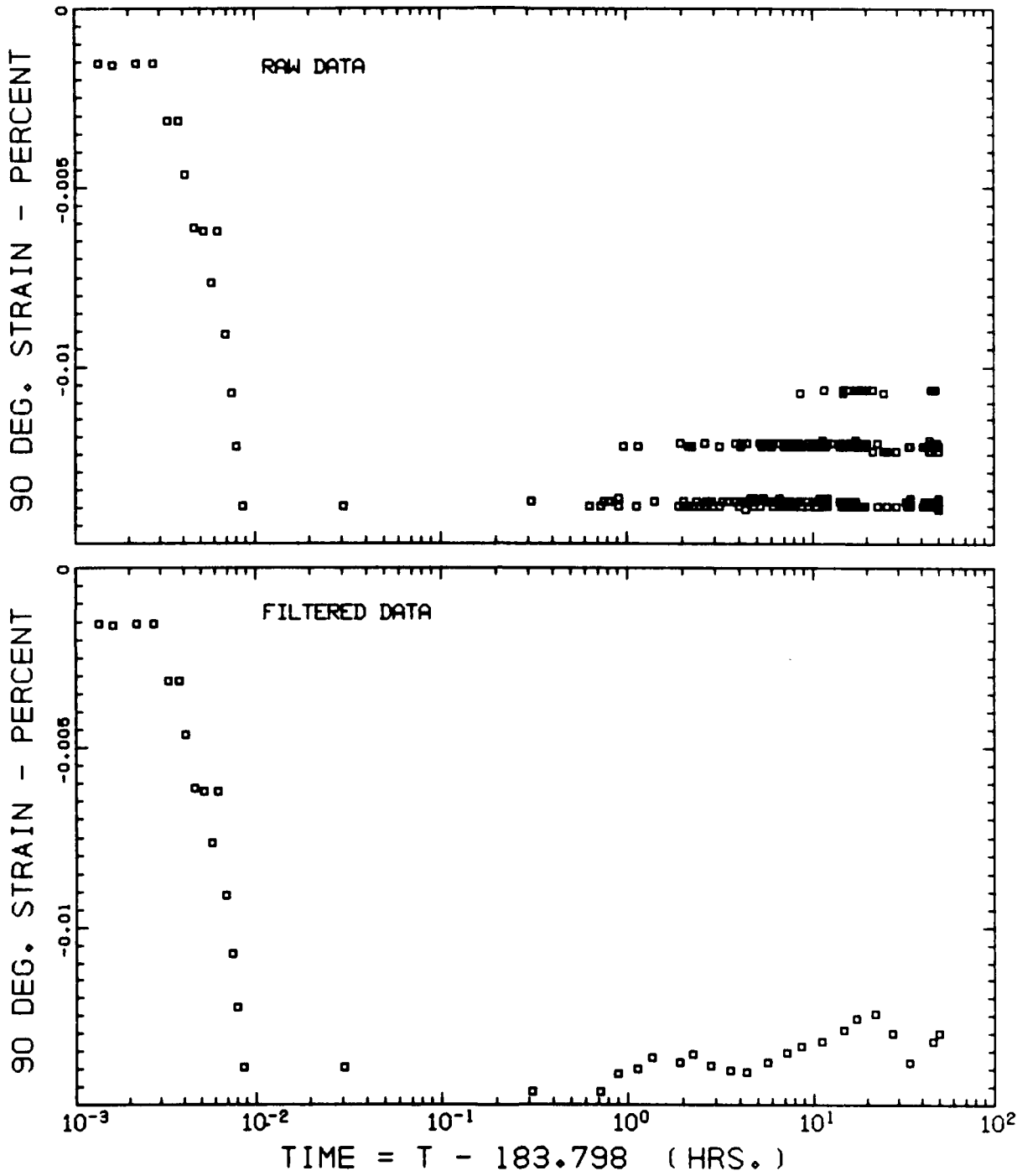



T300/5208 - STEP/RELAXATION - SPECIMEN No. 2 - STEP No. 6

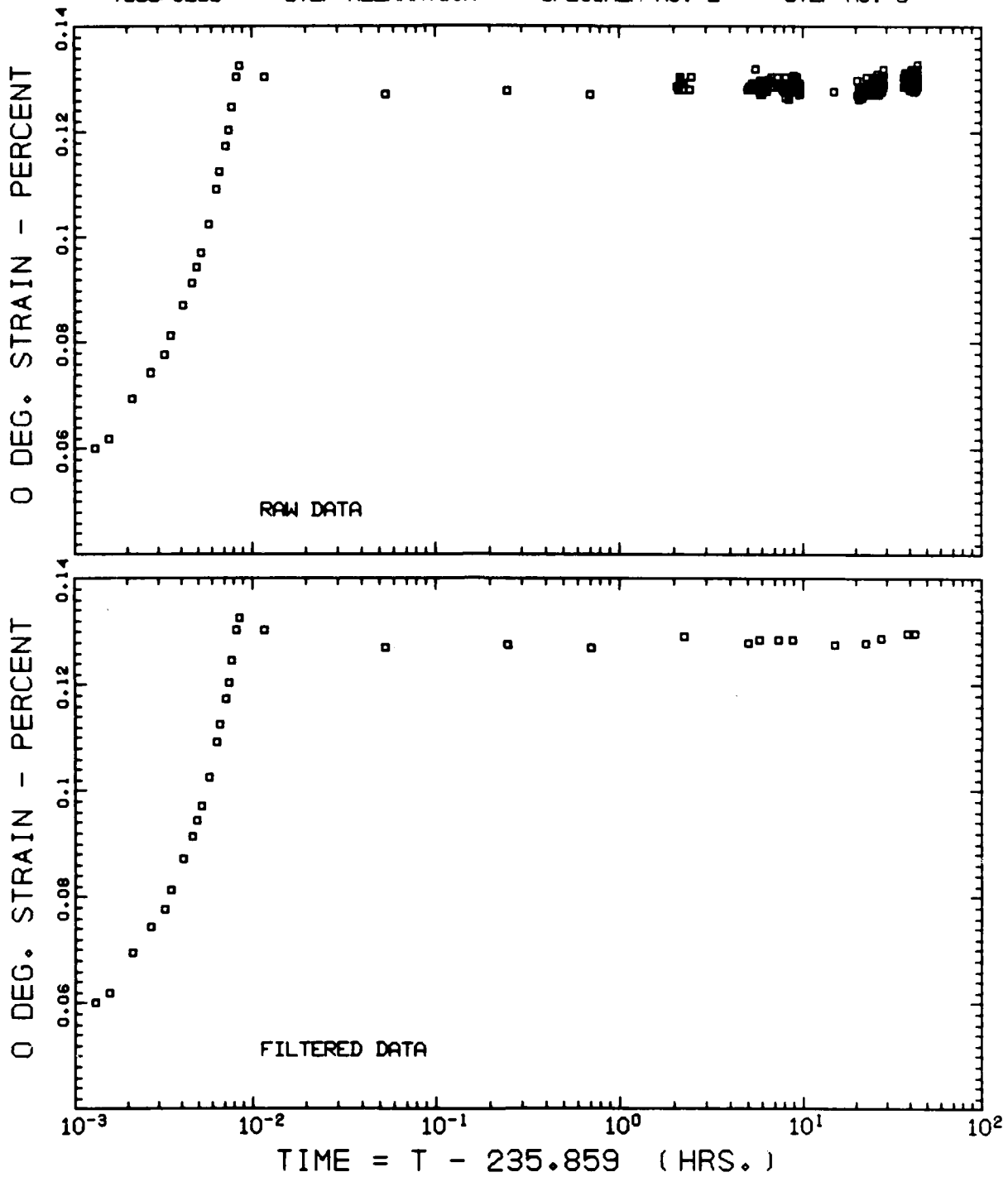

T300/5208 - STEP/RELAXATION - SPECIMEN No. 2 - STEP No. 6

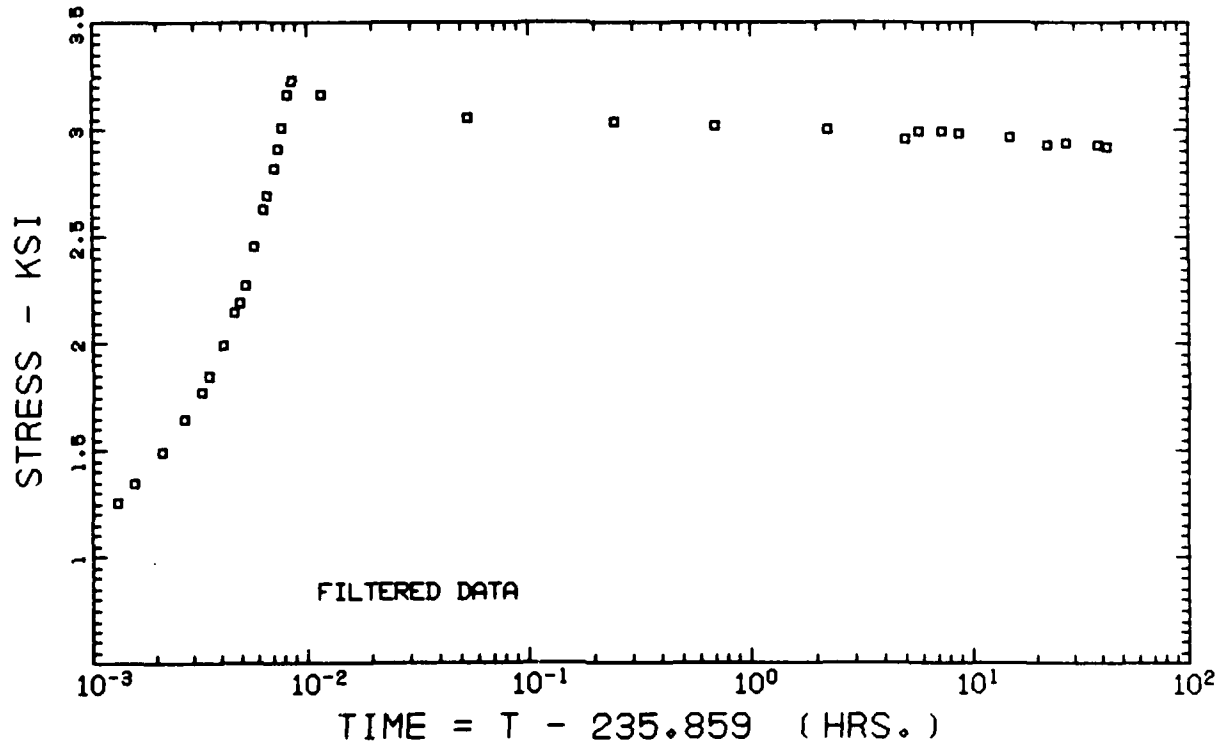
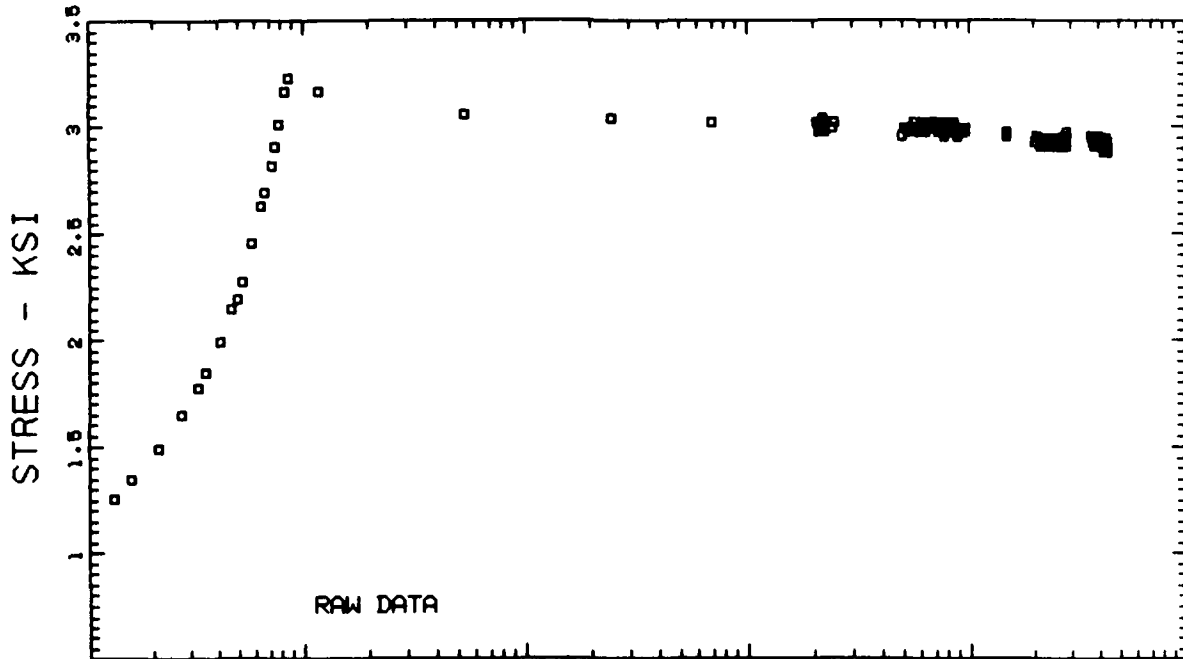

T300/5208 - STEP/RELAXATION - SPECIMEN No. 2 - STEP No. 6

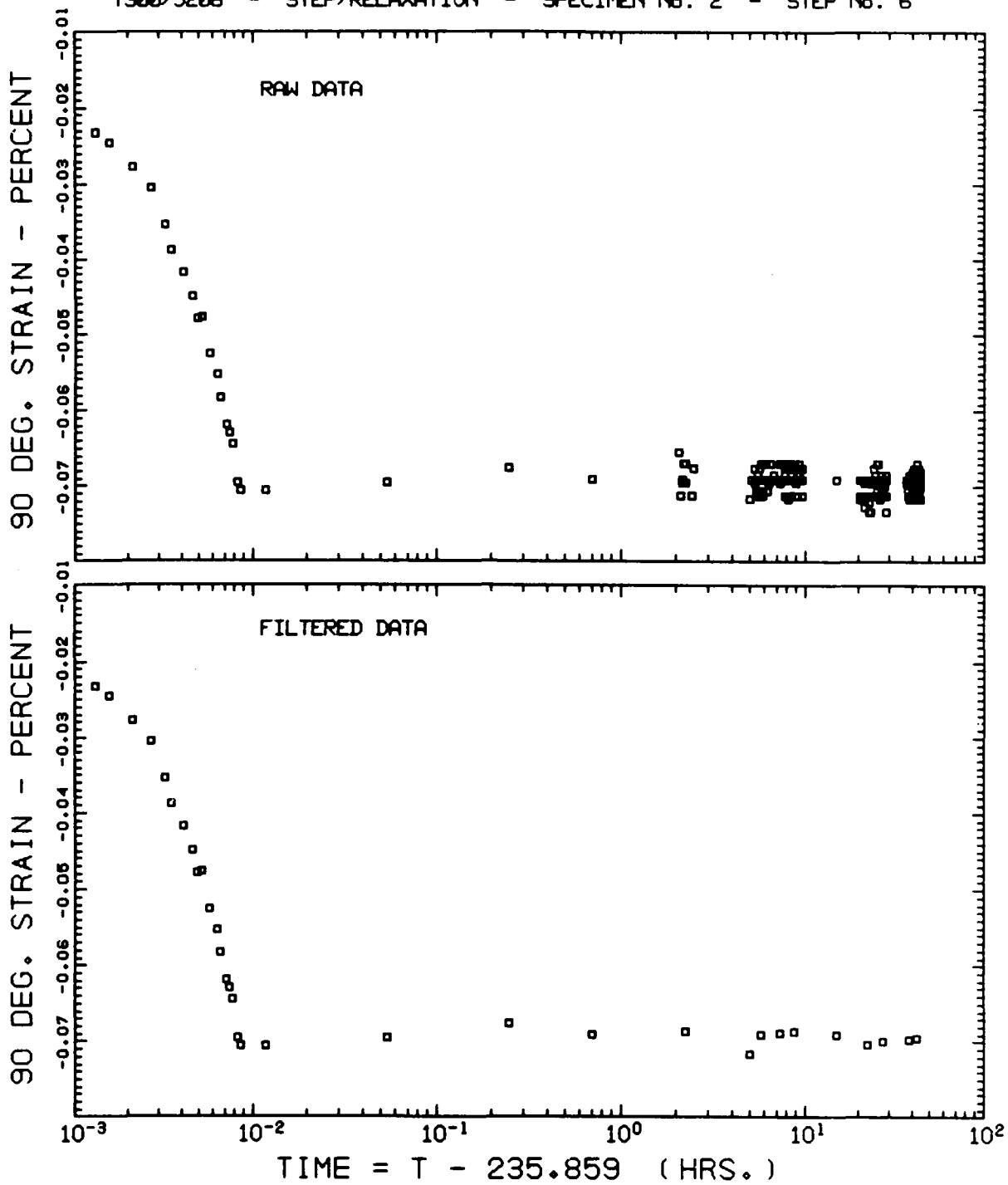

T300/S208 - STEP RELAXATION - SPECIMEN No. 2 - STEP No. 7

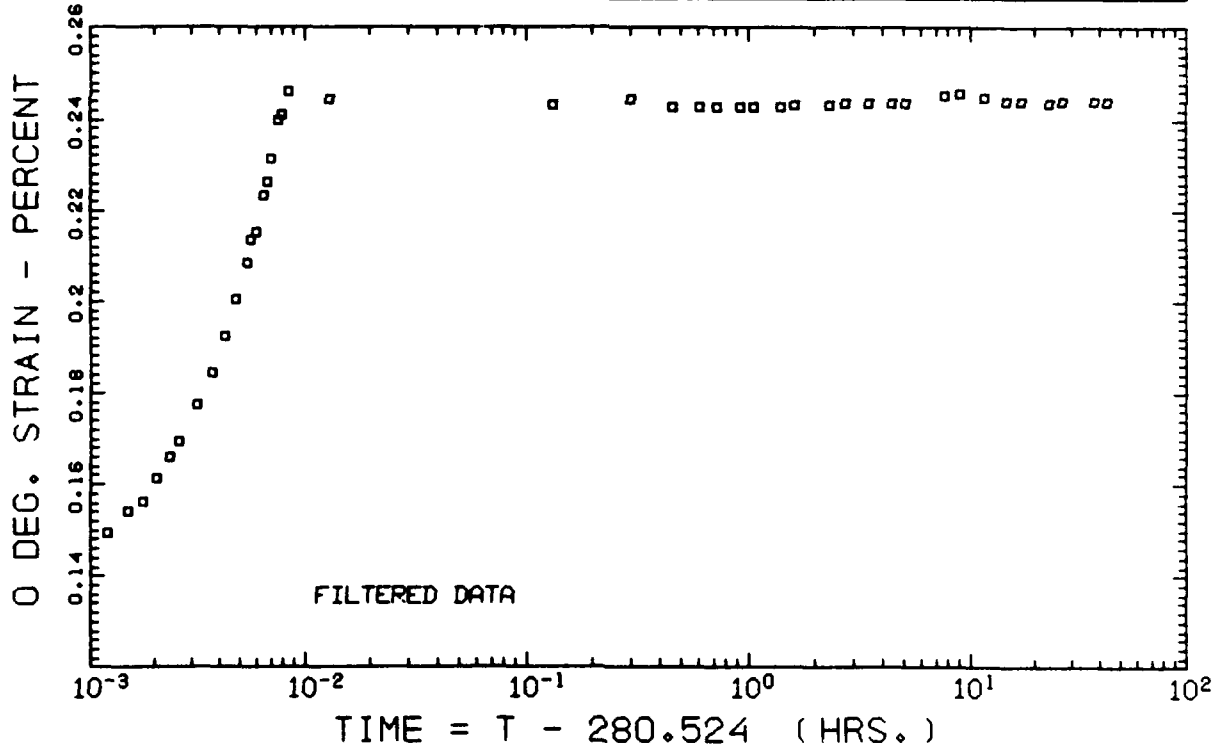
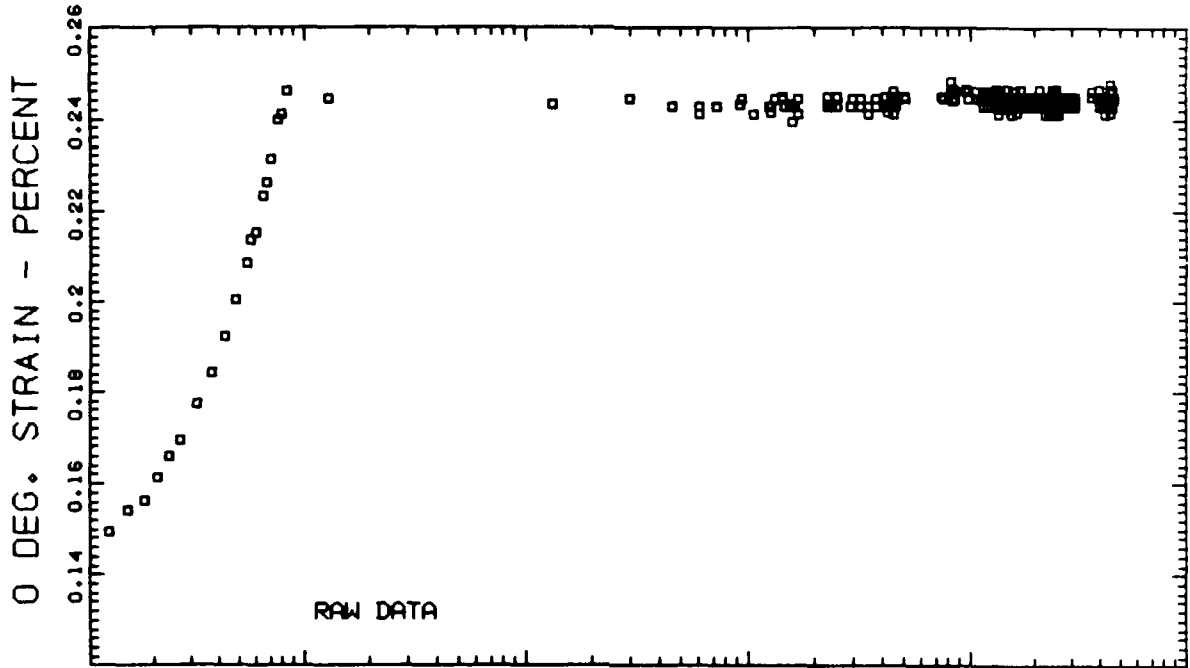

T300/5208 - STEP/RELAXATION - SPECIMEN No. 2 - STEP No. 7

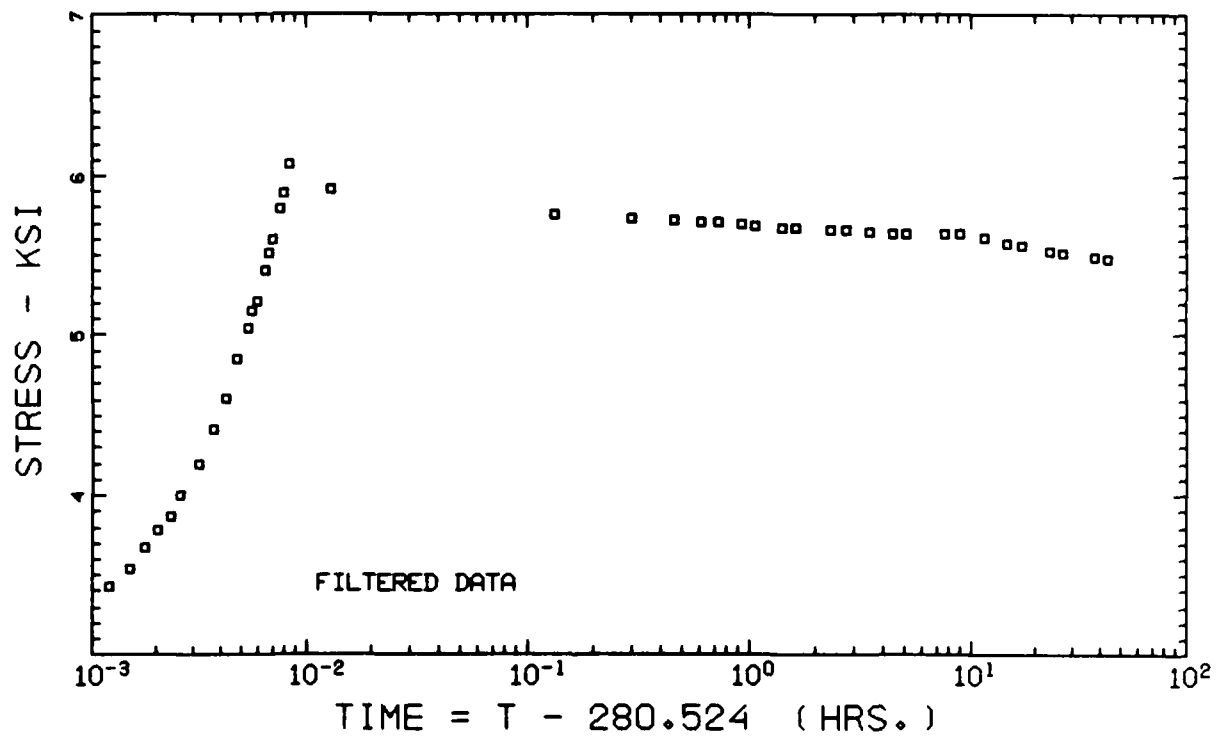
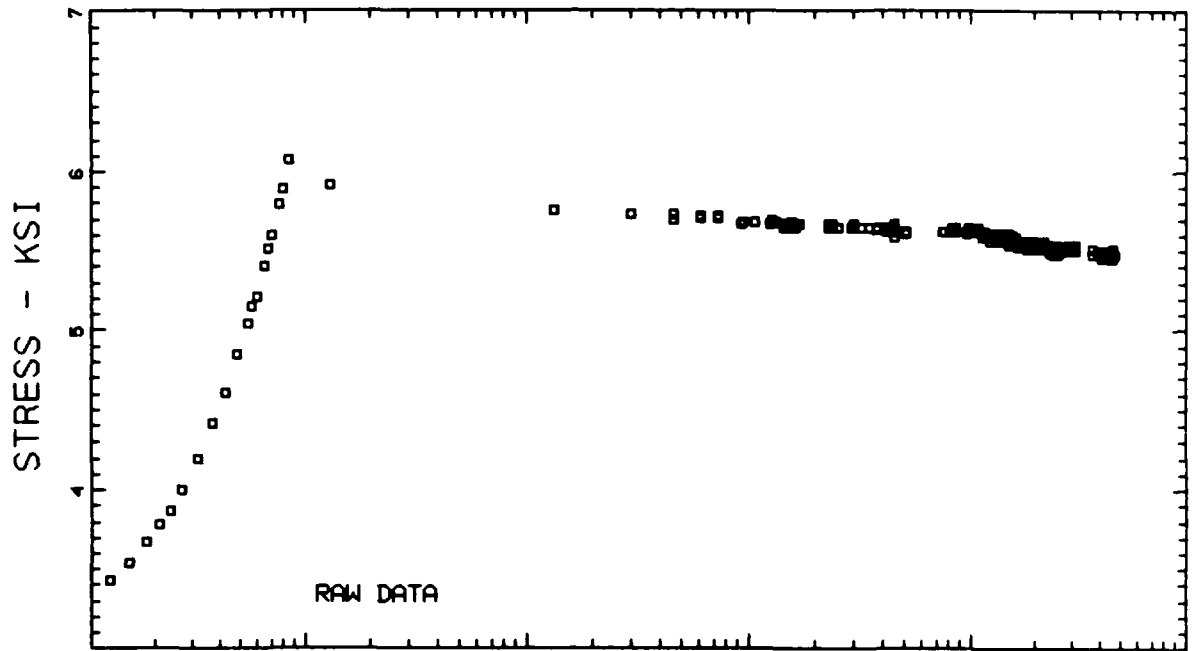

T300/5208 - STEP/RELAXATION - SPECIMEN No. 2 - STEP No. 7

90 DEG. STRAIN - PERCENT

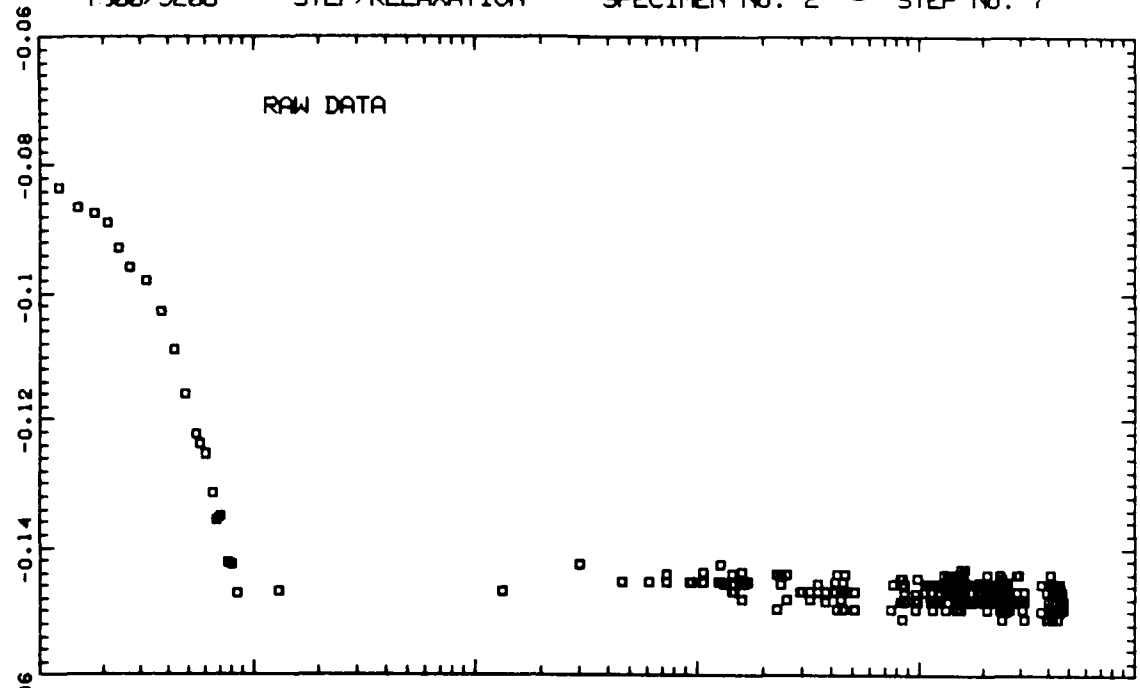

90 DEG. STRAIN - PERCENT

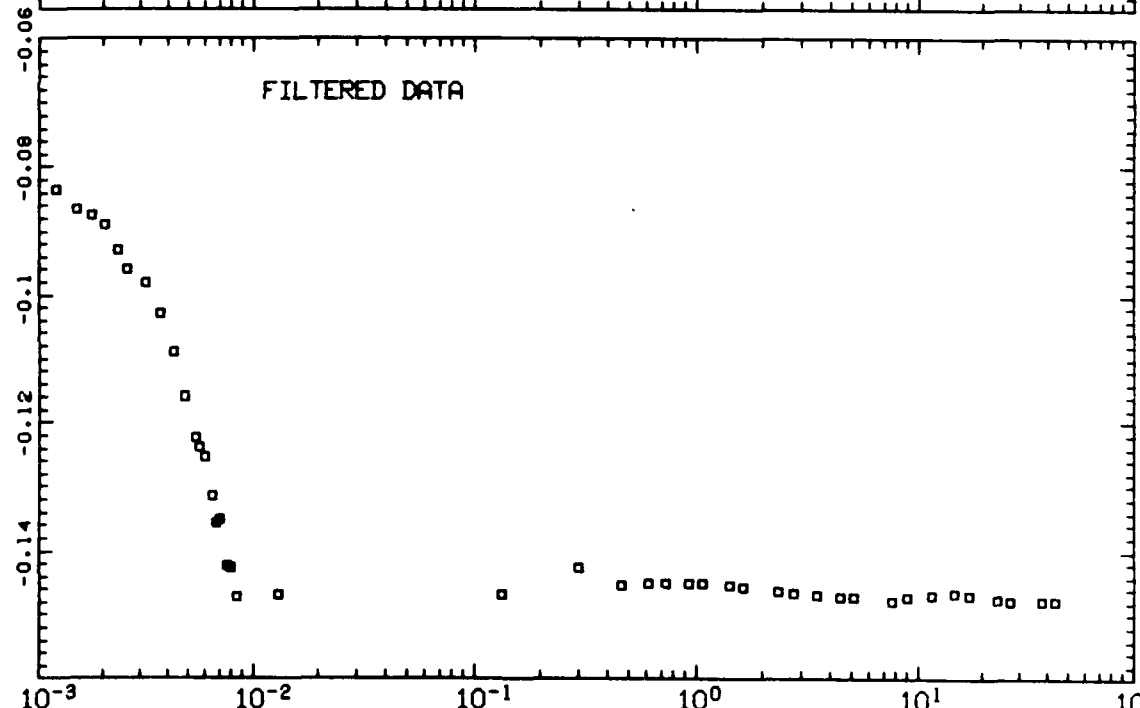

TIME = T - 280.524 (HRS.)

T300/5208 - STEP/RELAXATION - SPECIMEN No. 2 - STEP No. 8

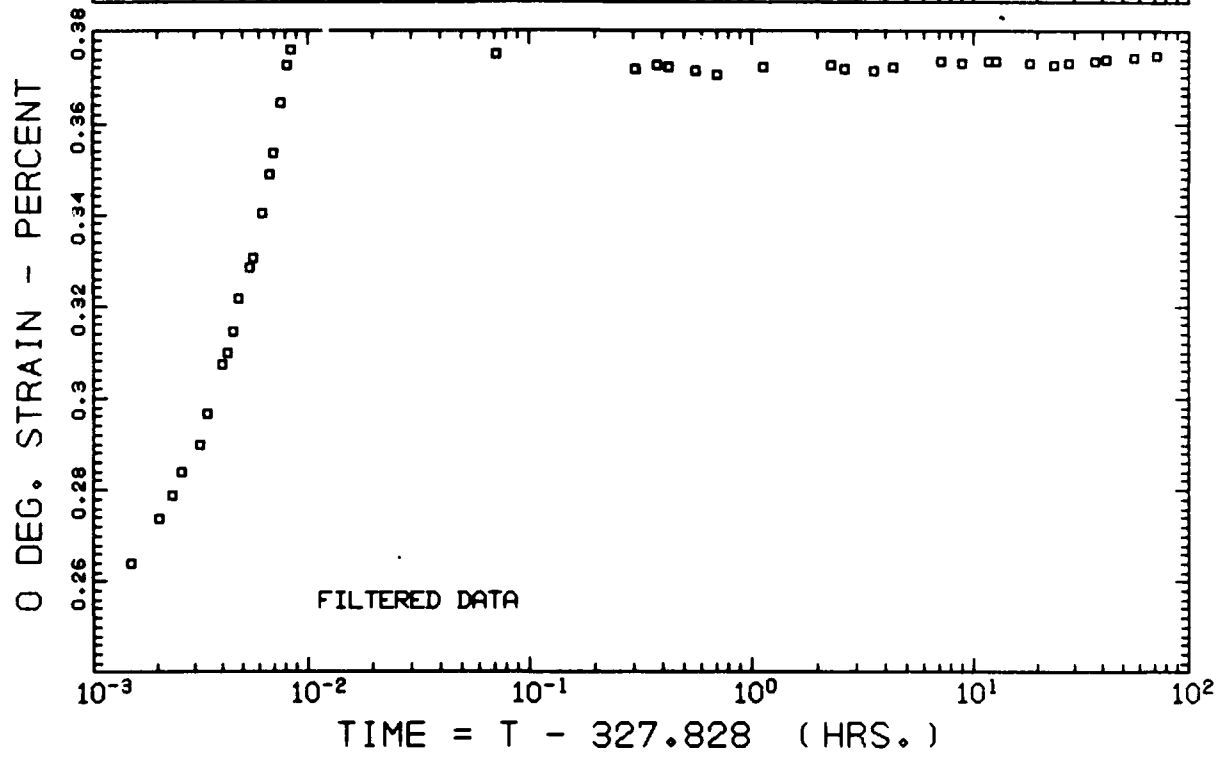
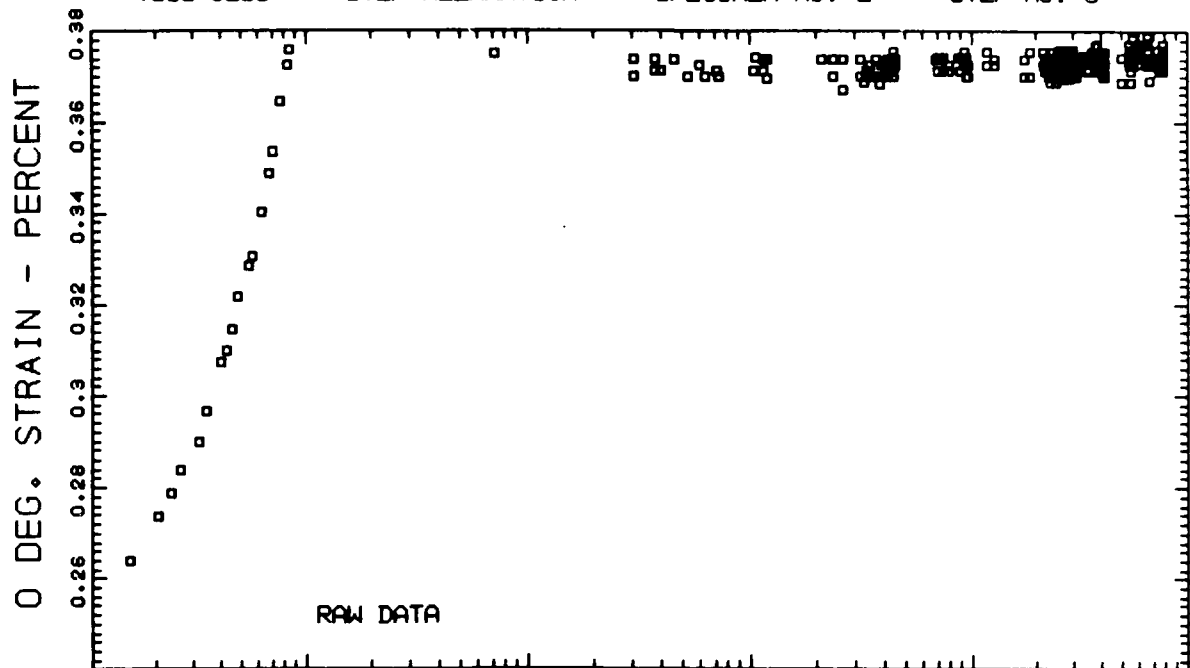

T300/5208 - STEP/RELAXATION - SPECIMEN No. 2 - STEP No. 8

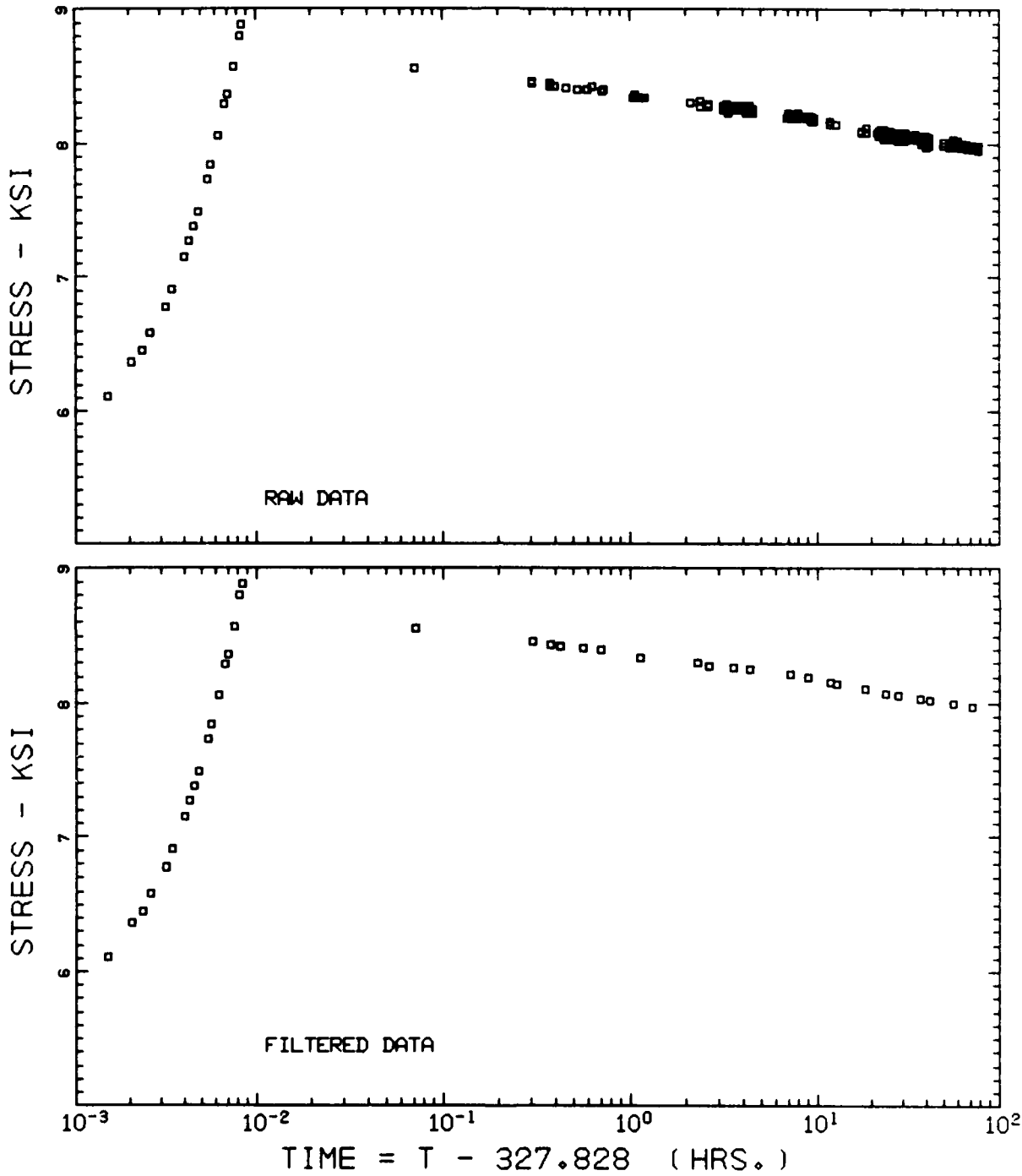



T300/5208 - STEP/RELAXATION - SPECIMEN No. 2 - STEP No. 8

90 DEG. STRAIN - PERCENT

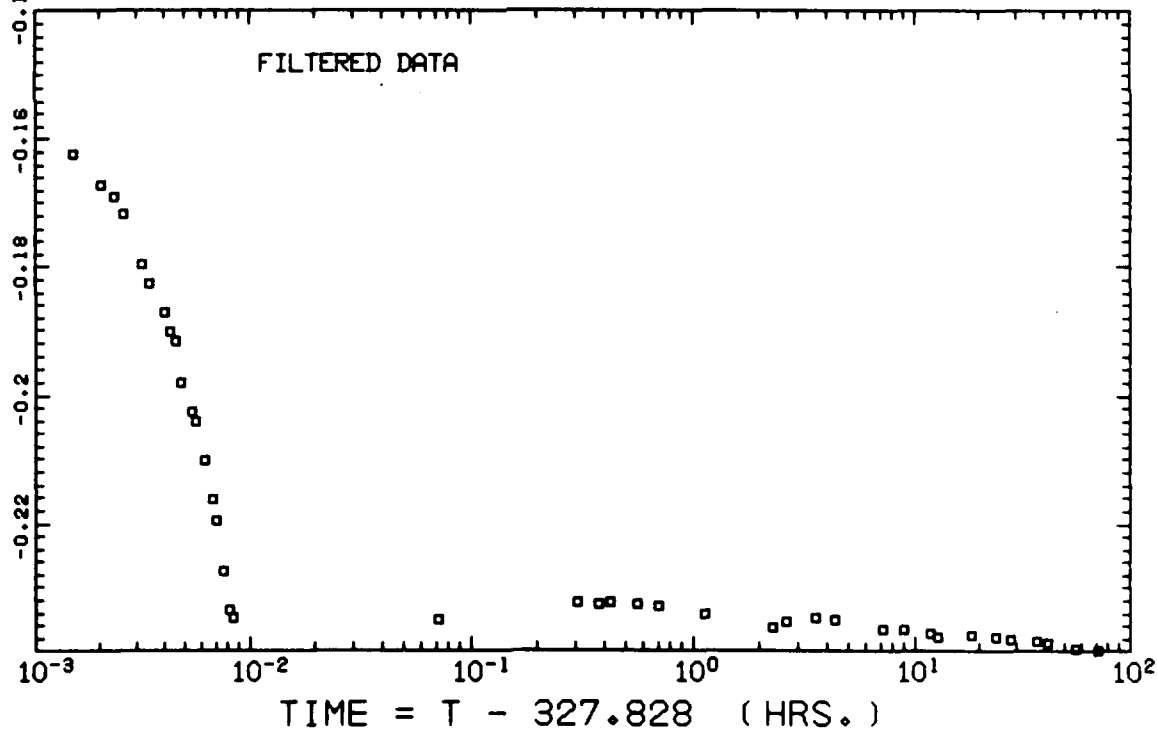
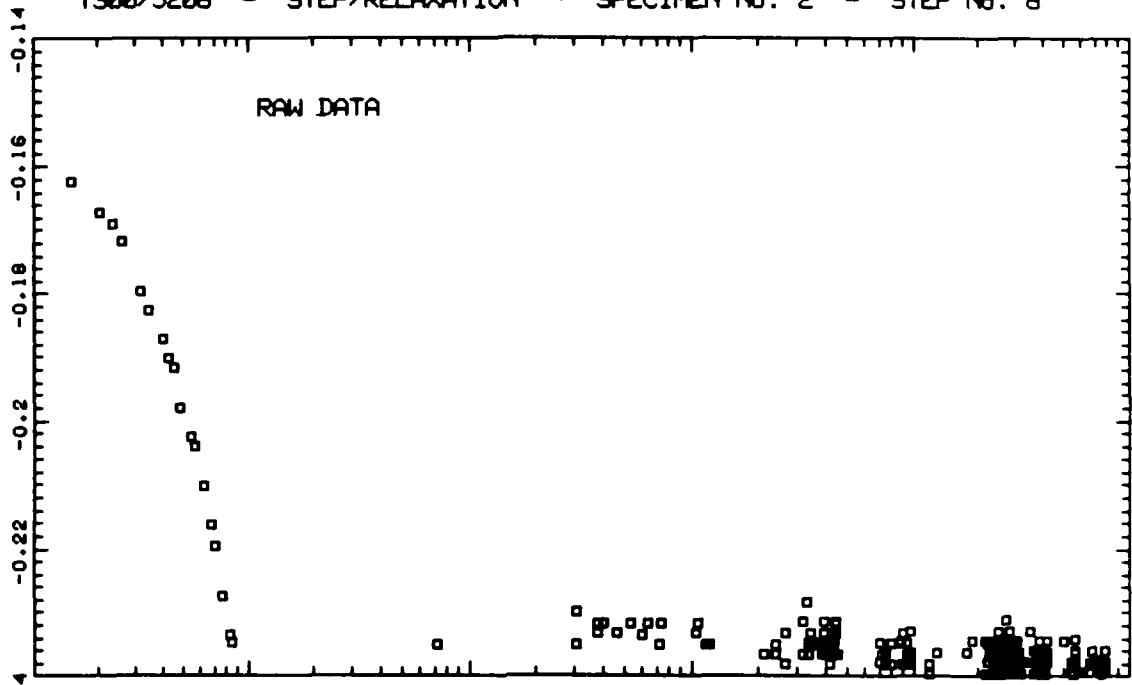

TIME = T - 327.828 (HRS.)

T300/5208 - STEP/RELAXATION - SPECIMEN No. 2 - STEP No. 9

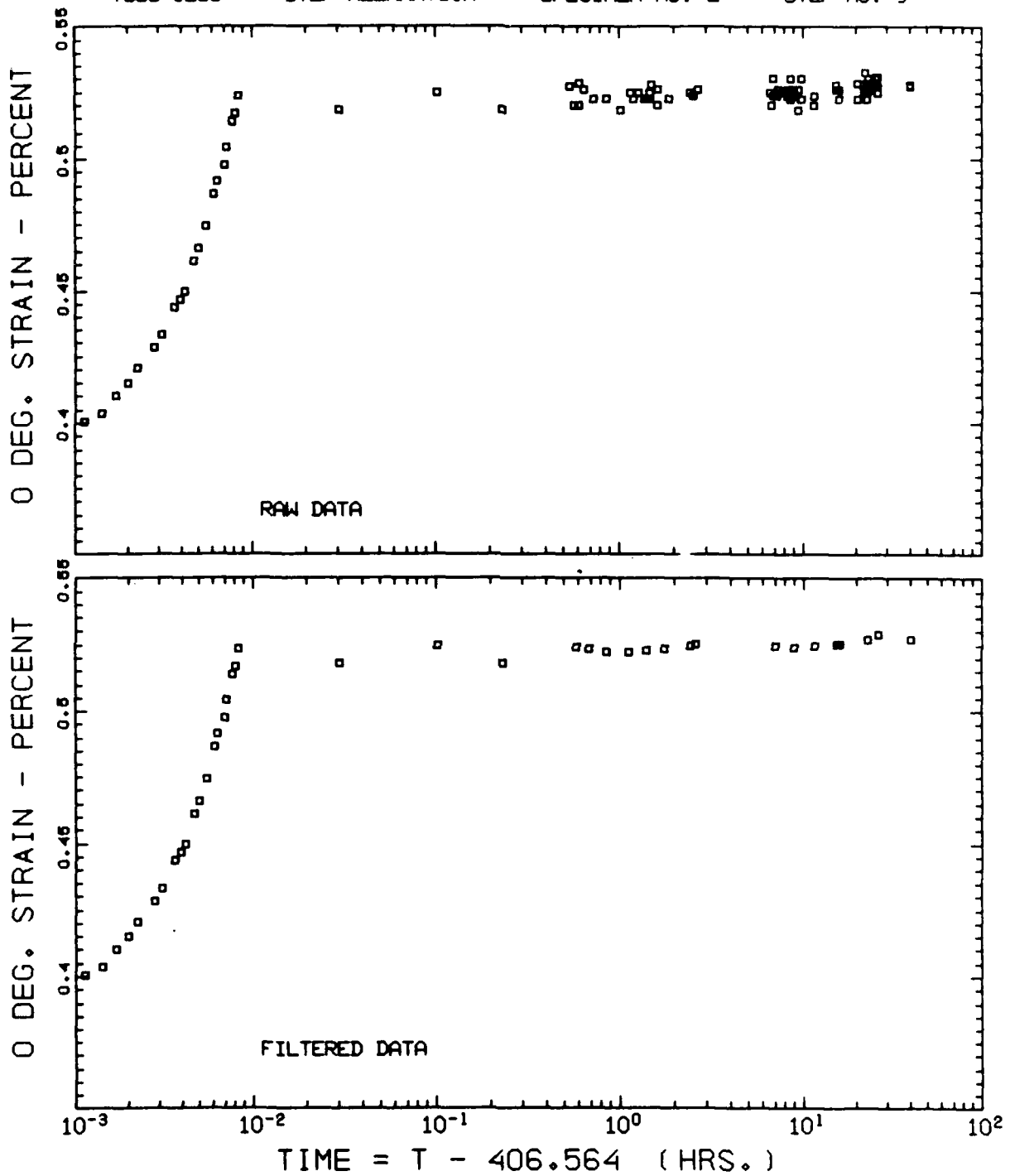

T300/5208 - STEP/RELAXATION - SPECIMEN No. 2 - STEP No. 9

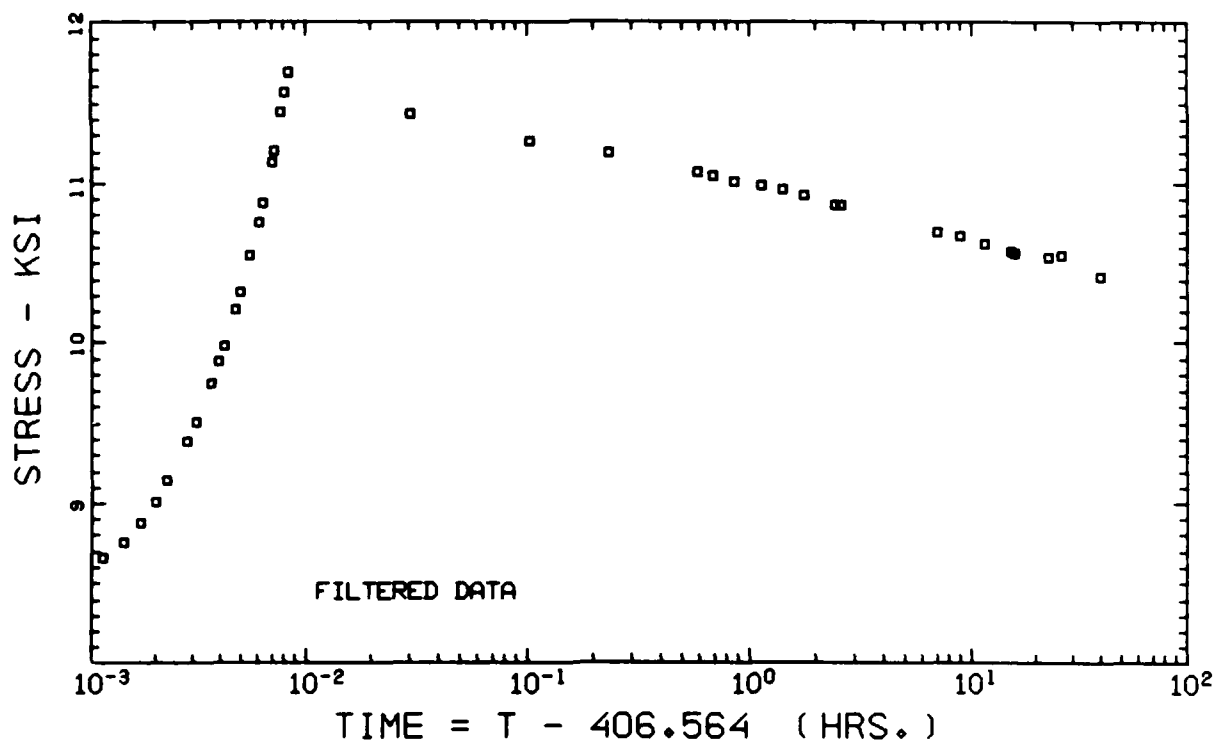
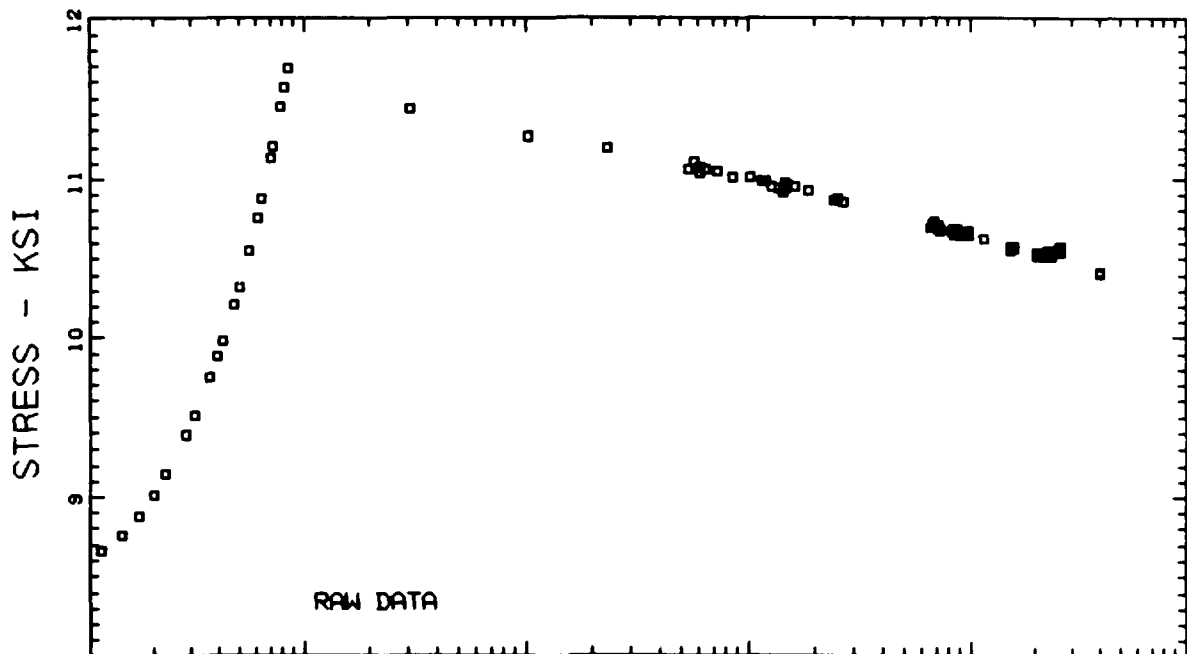

T300/S208 - STEP/RELAXATION - SPECIMEN No. 2 - STEP No. 9

90 DEG. STRAIN - PERCENT

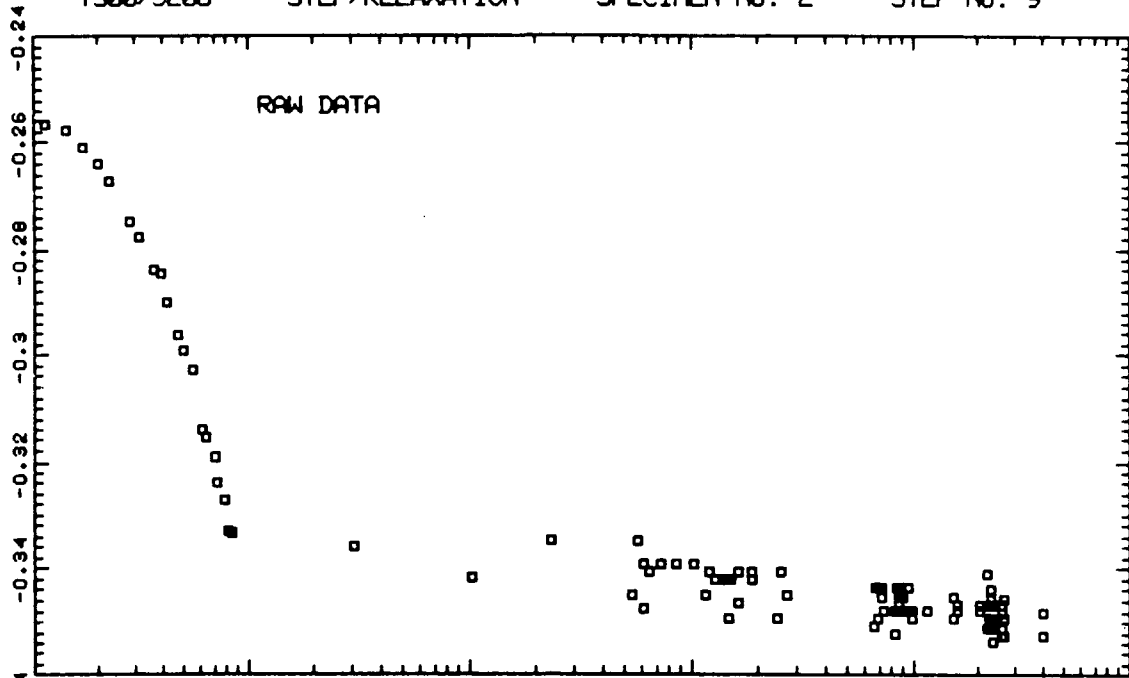

90 DEG. STRAIN - PERCENT

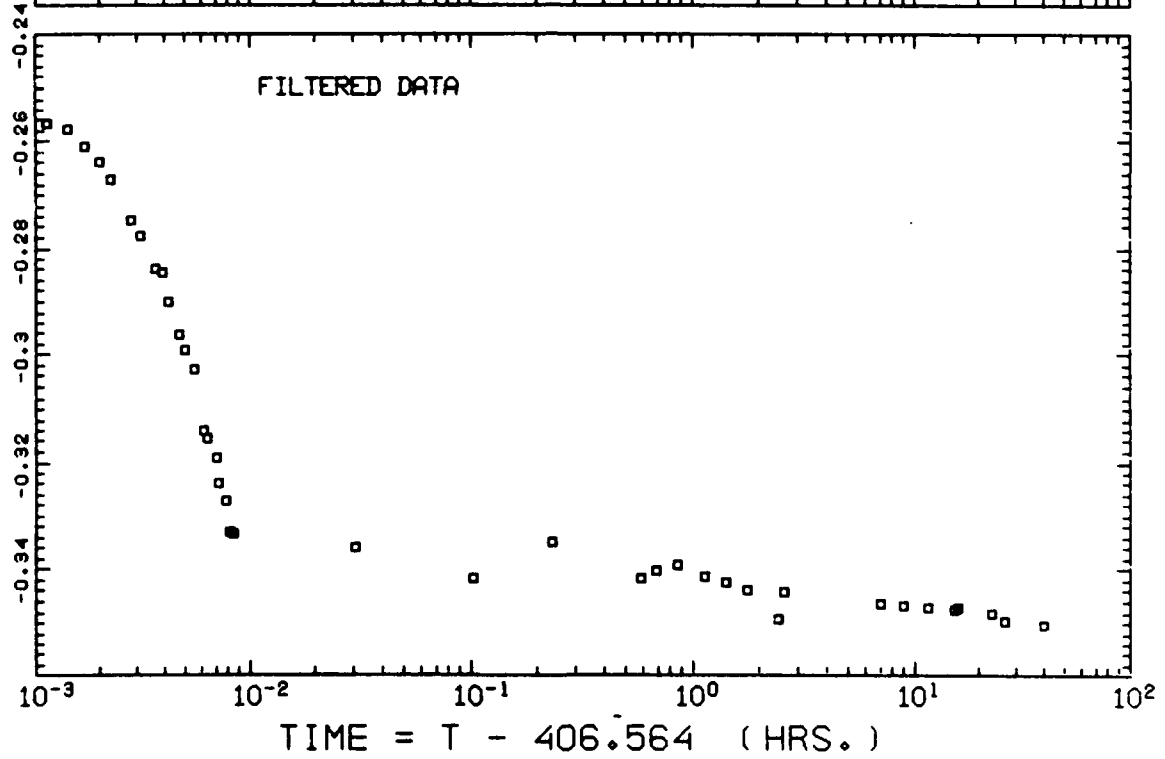

TIME = T - 406.564 (HRS.)

T300/5208 - STEP/RELAXATION - SPECIMEN NO. 3

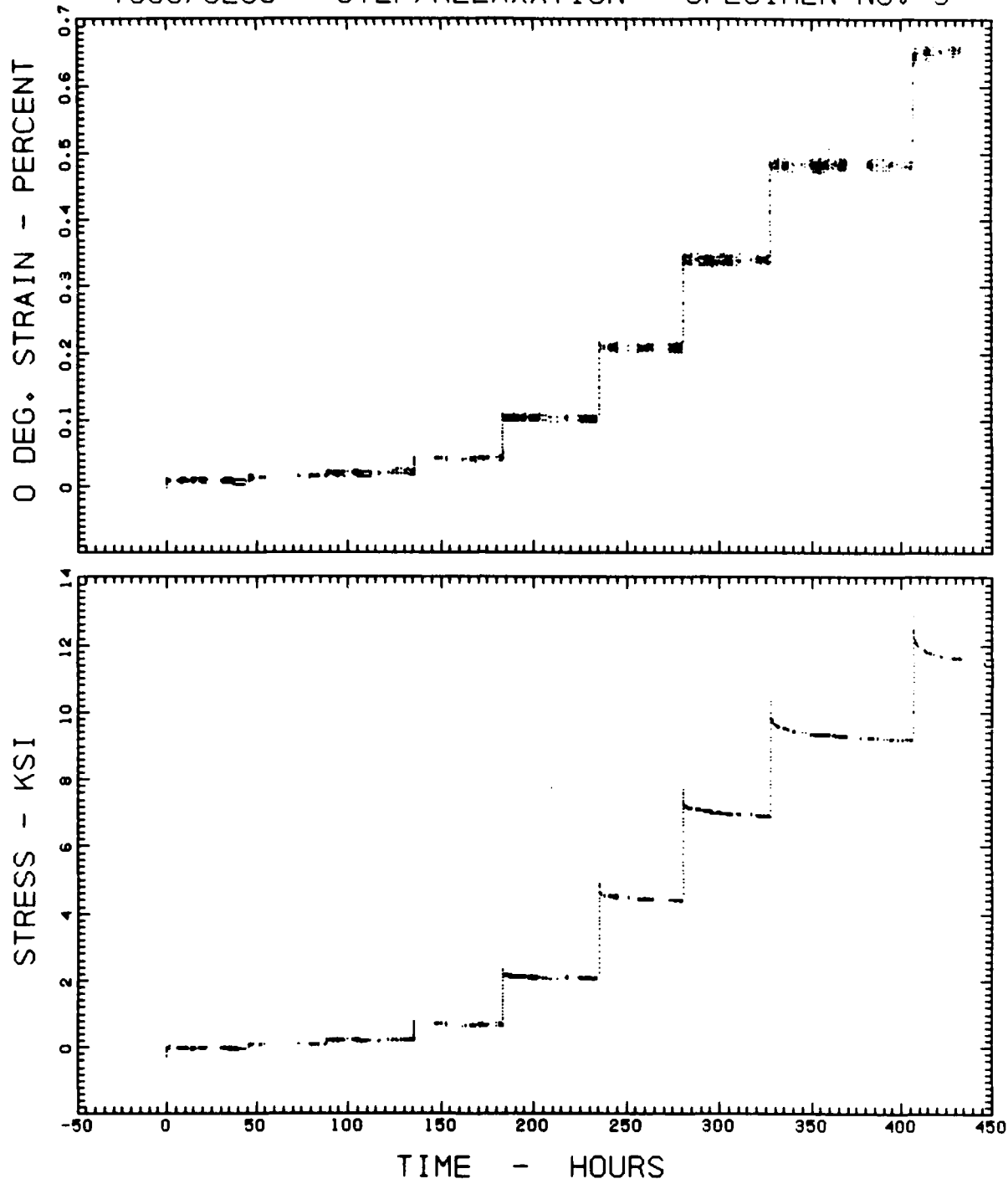

T300/5208 - STEP/RELAXATION - SPECIMEN NO. 3

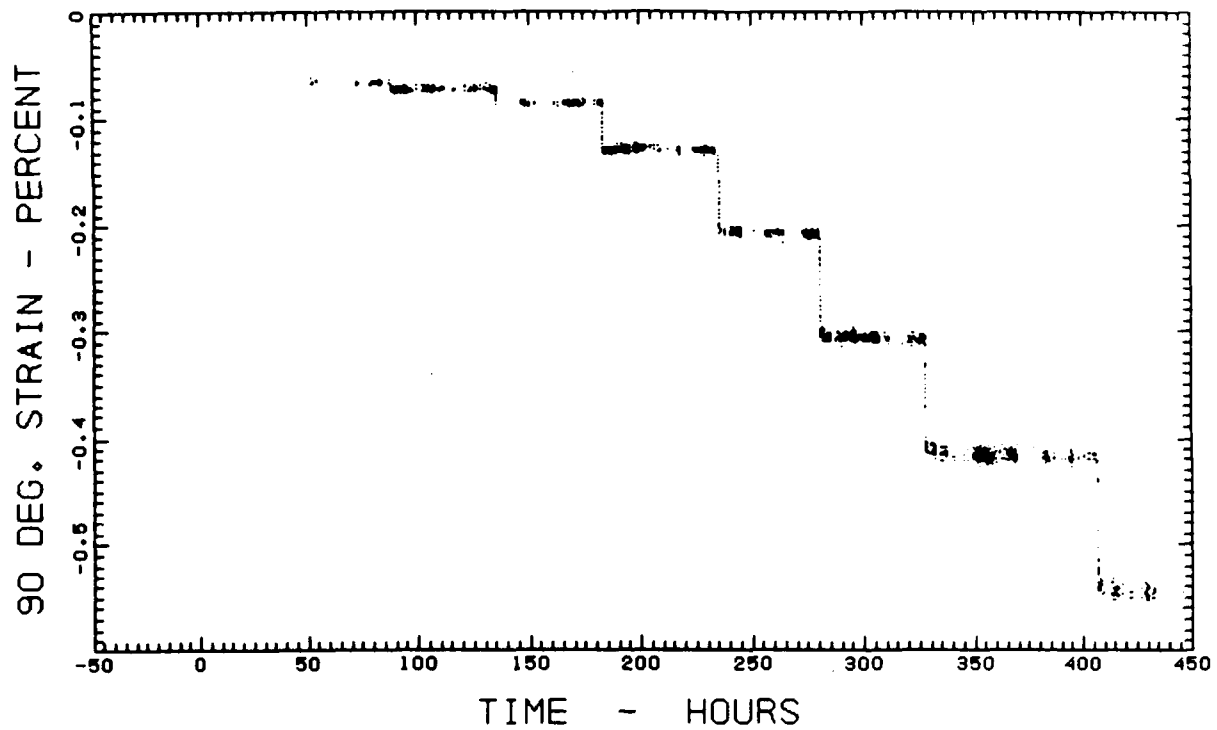

T300/5208 - STEP/RELAXATION - SPECIMEN No. 3 - STEP No. 4

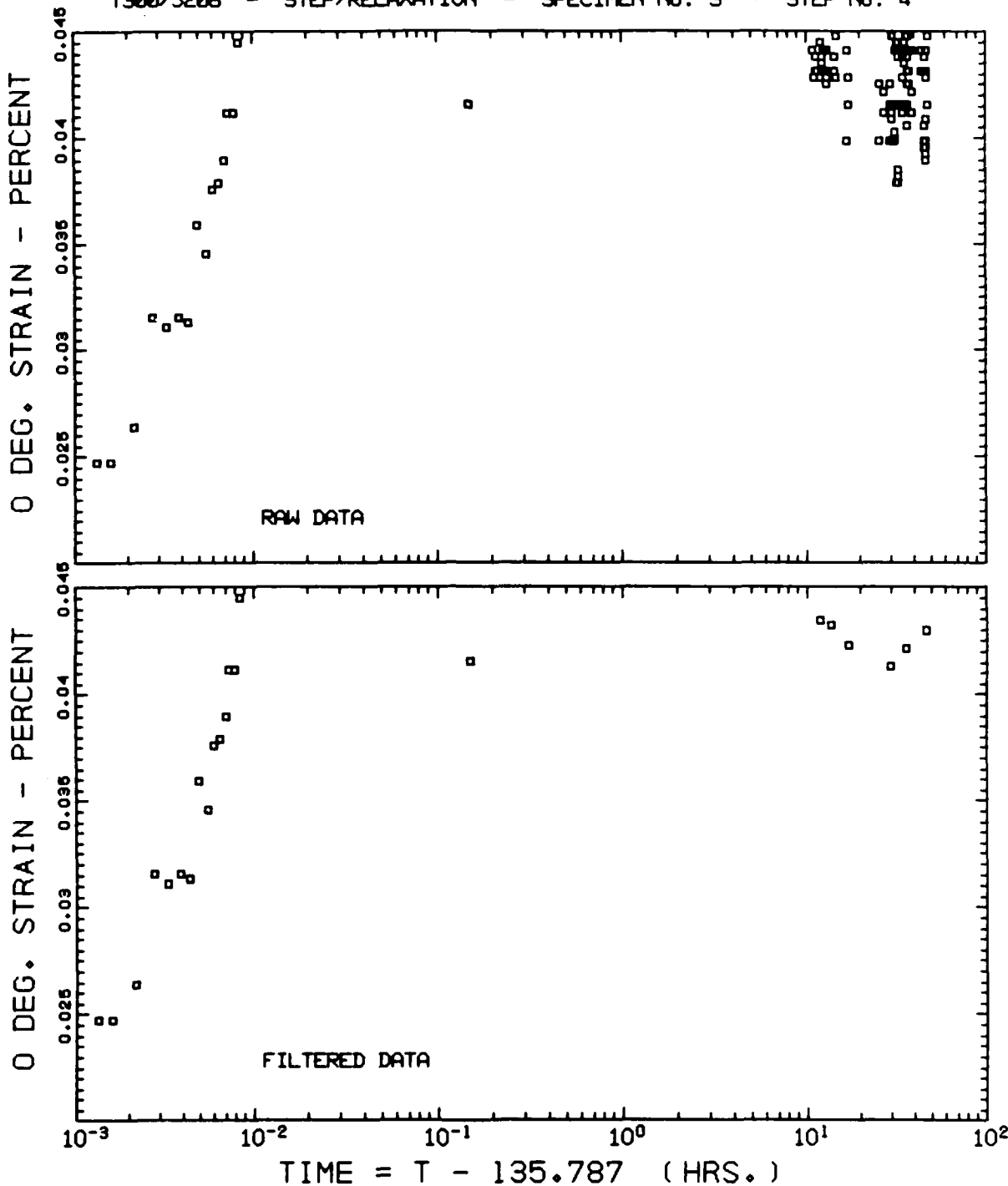

T300/5208 - STEP/RELAXATION - SPECIMEN No. 3 - STEP No. 4

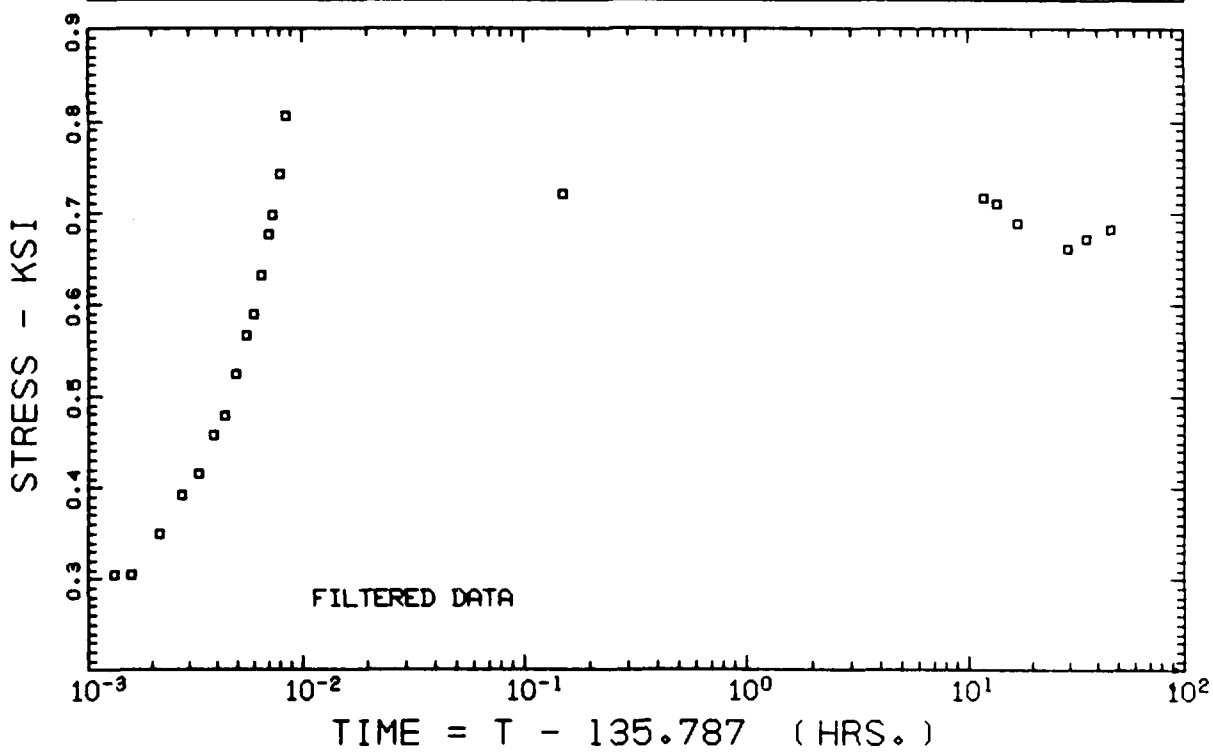
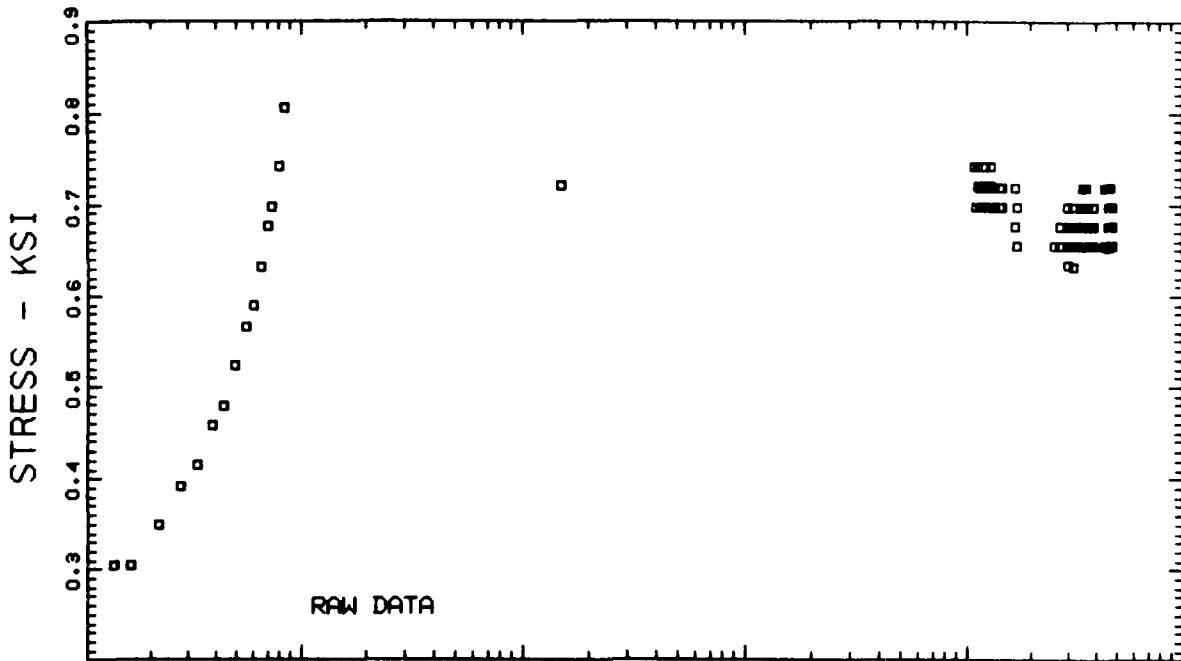



T300/5208 - STEP/RELAXATION - SPECIMEN No. 3 - STEP No. 4

90 DEG. STRAIN - PERCENT

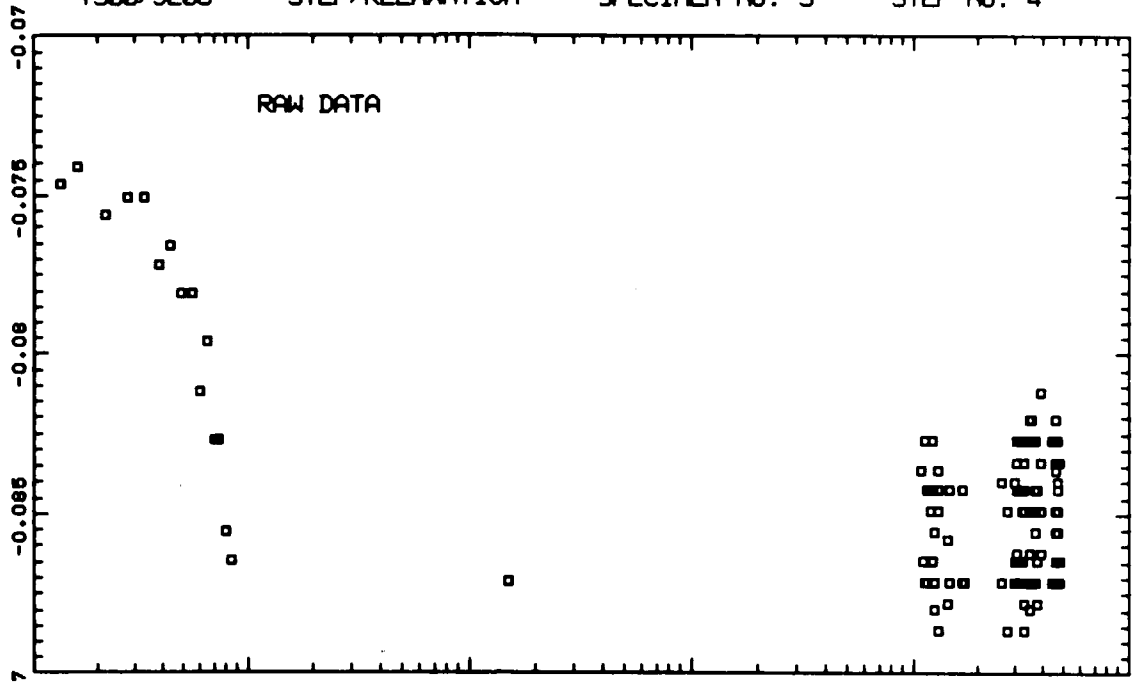

90 DEG. STRAIN - PERCENT

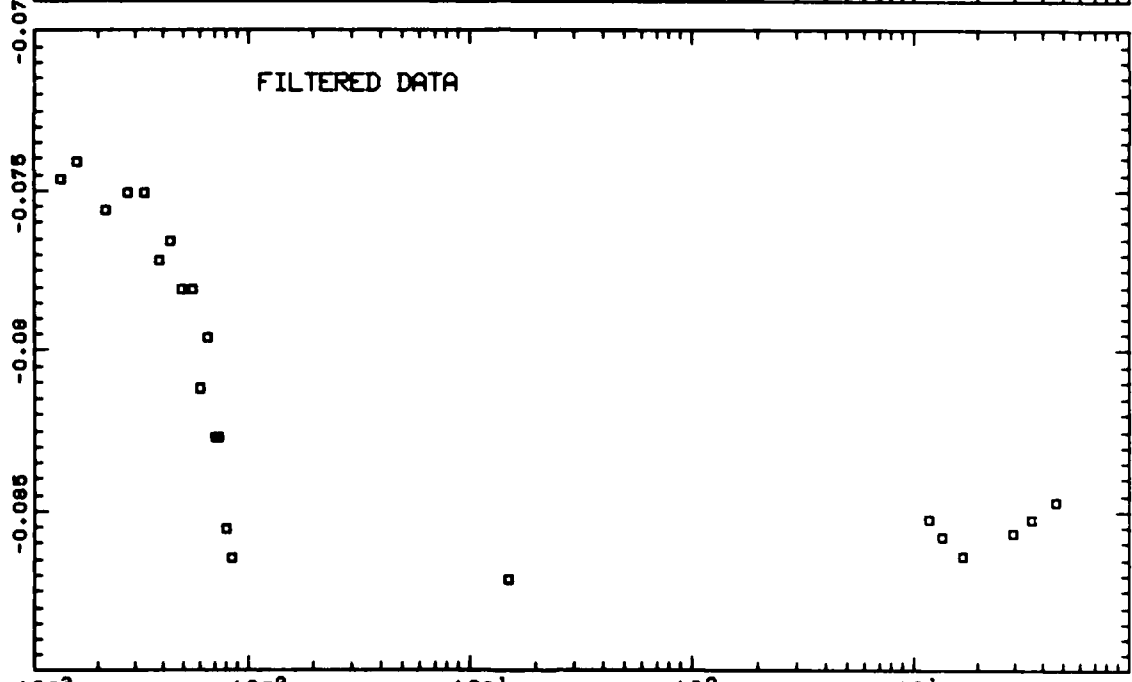

TIME = T - 135.787 (HRS.)

T300/5208 - STEP/RELAXATION - SPECIMEN No. 3 - STEP No. 5

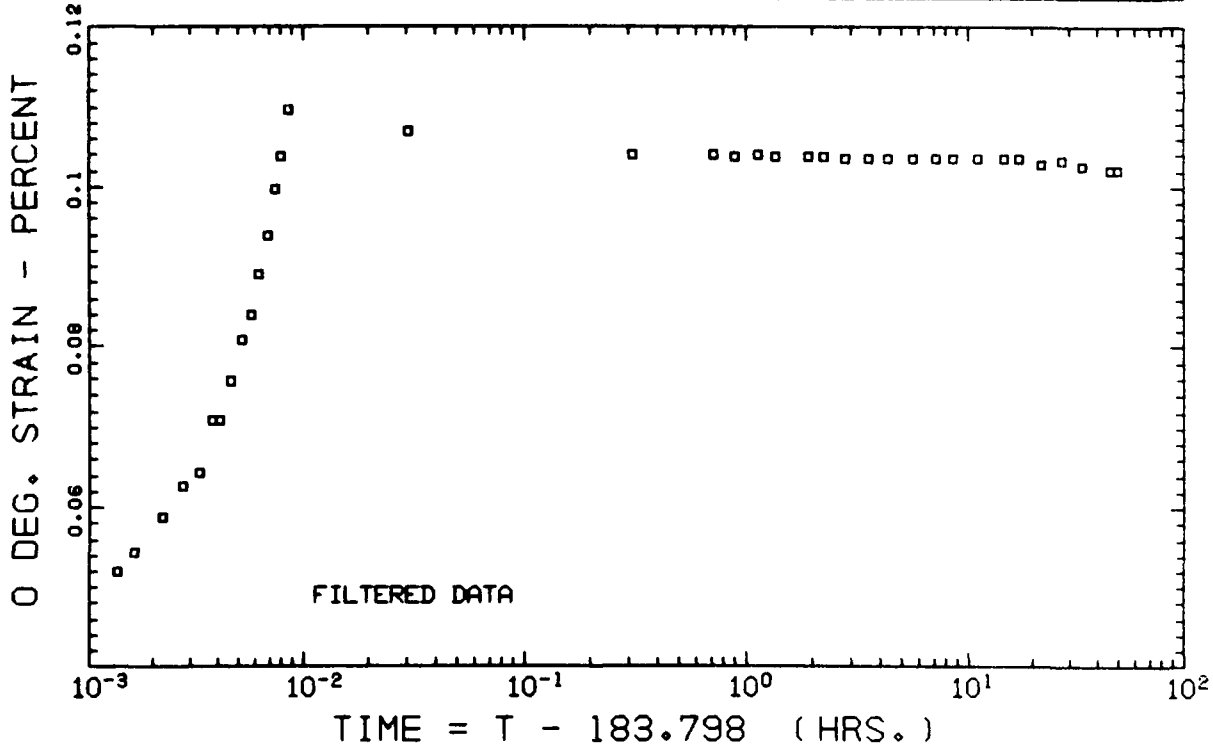
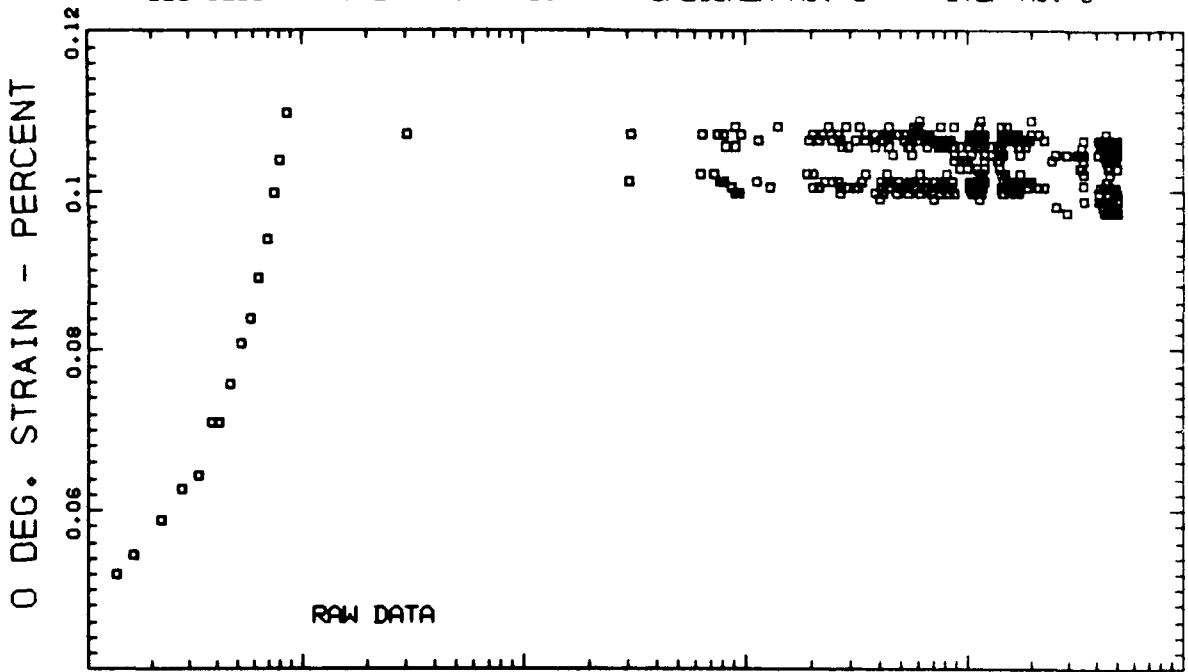

T300/5208 - STEP/RELAXATION - SPECIMEN No. 3 - STEP No. 5

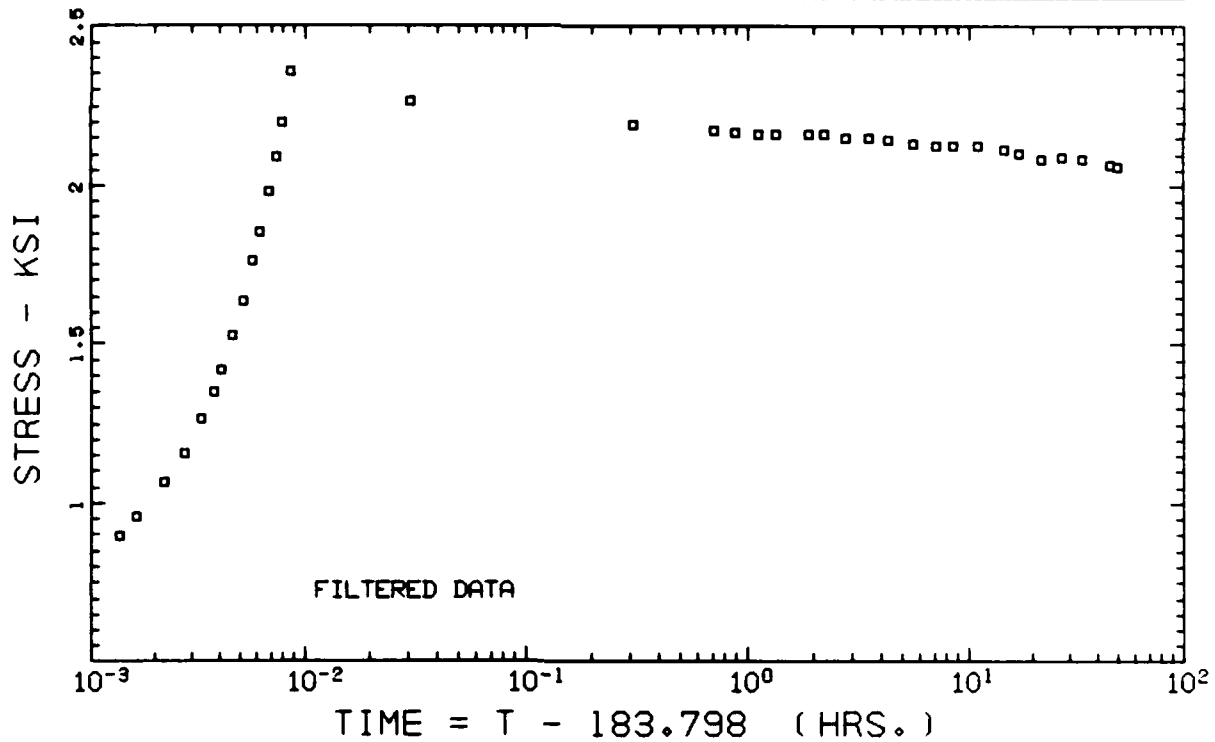
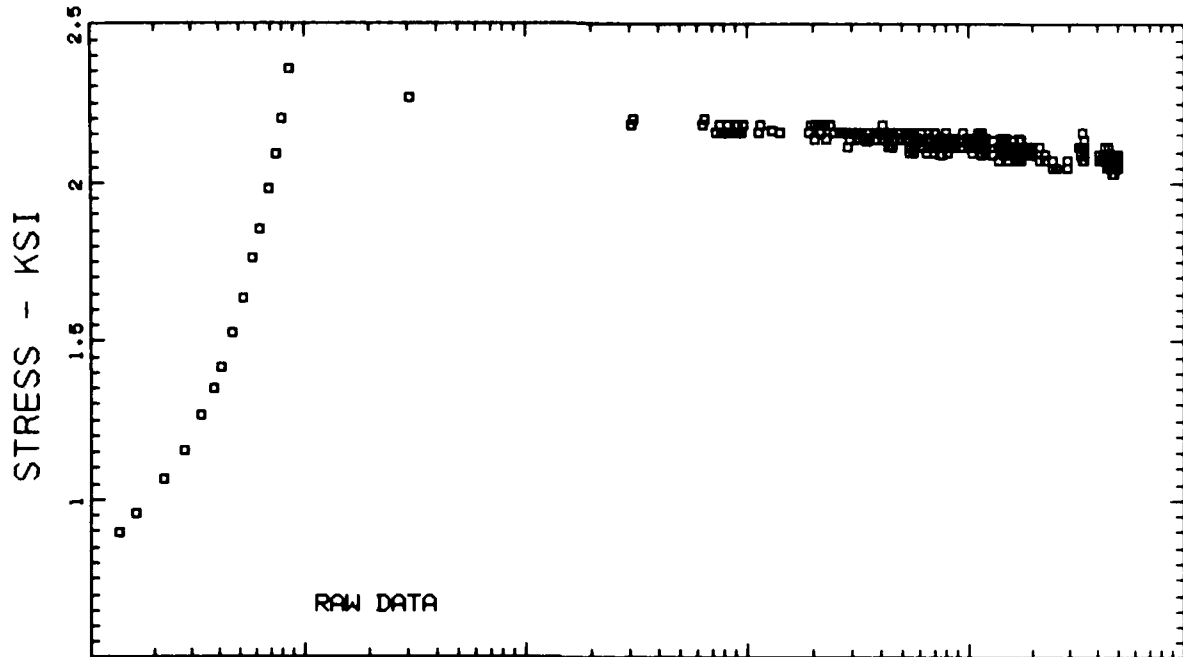

T300/5208 - STEP/RELAXATION - SPECIMEN No. 3 - STEP No. 5

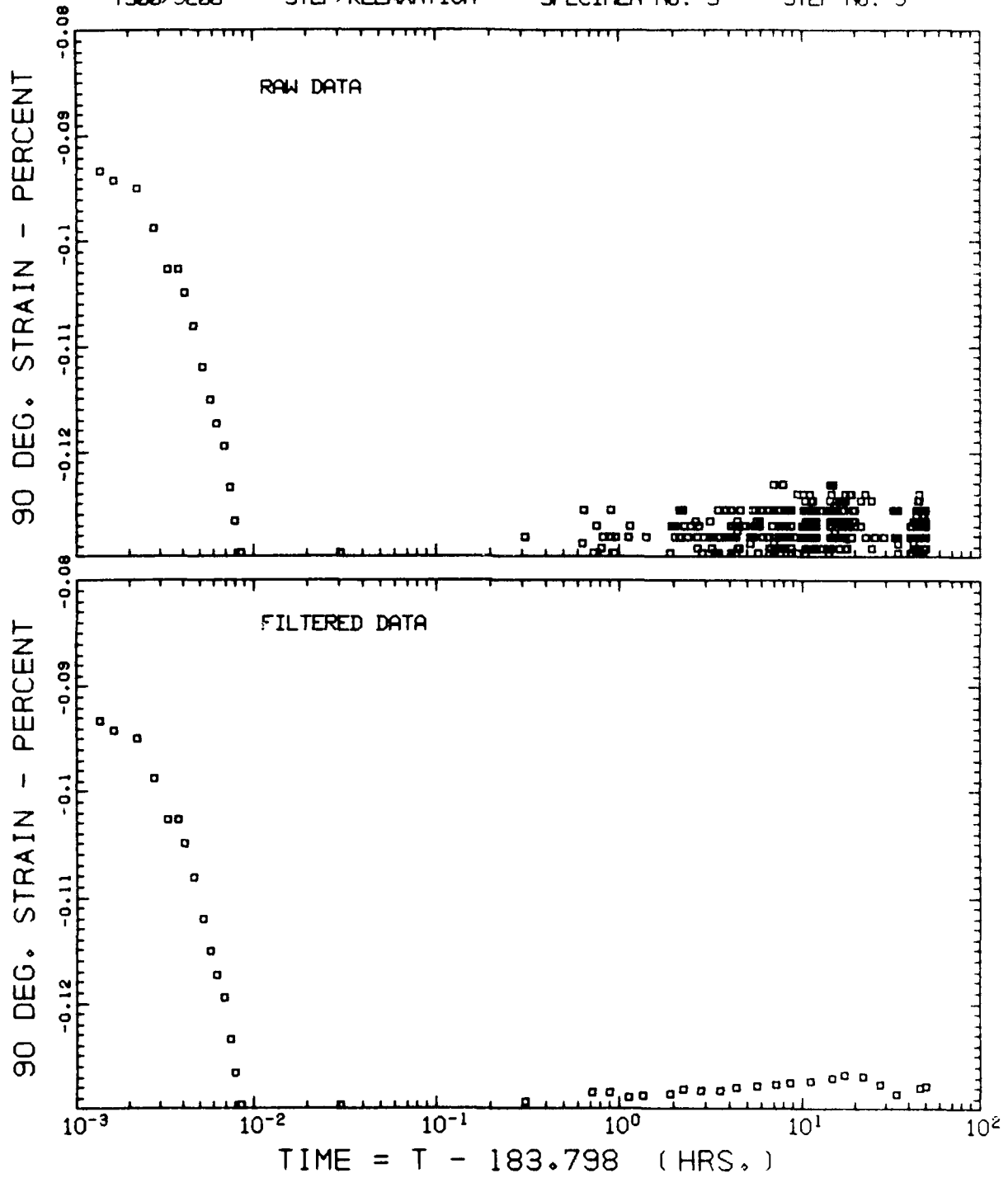

T320/5208 - STEP/RELAXATION - SPECIMEN No. 3 - STEP No. 6

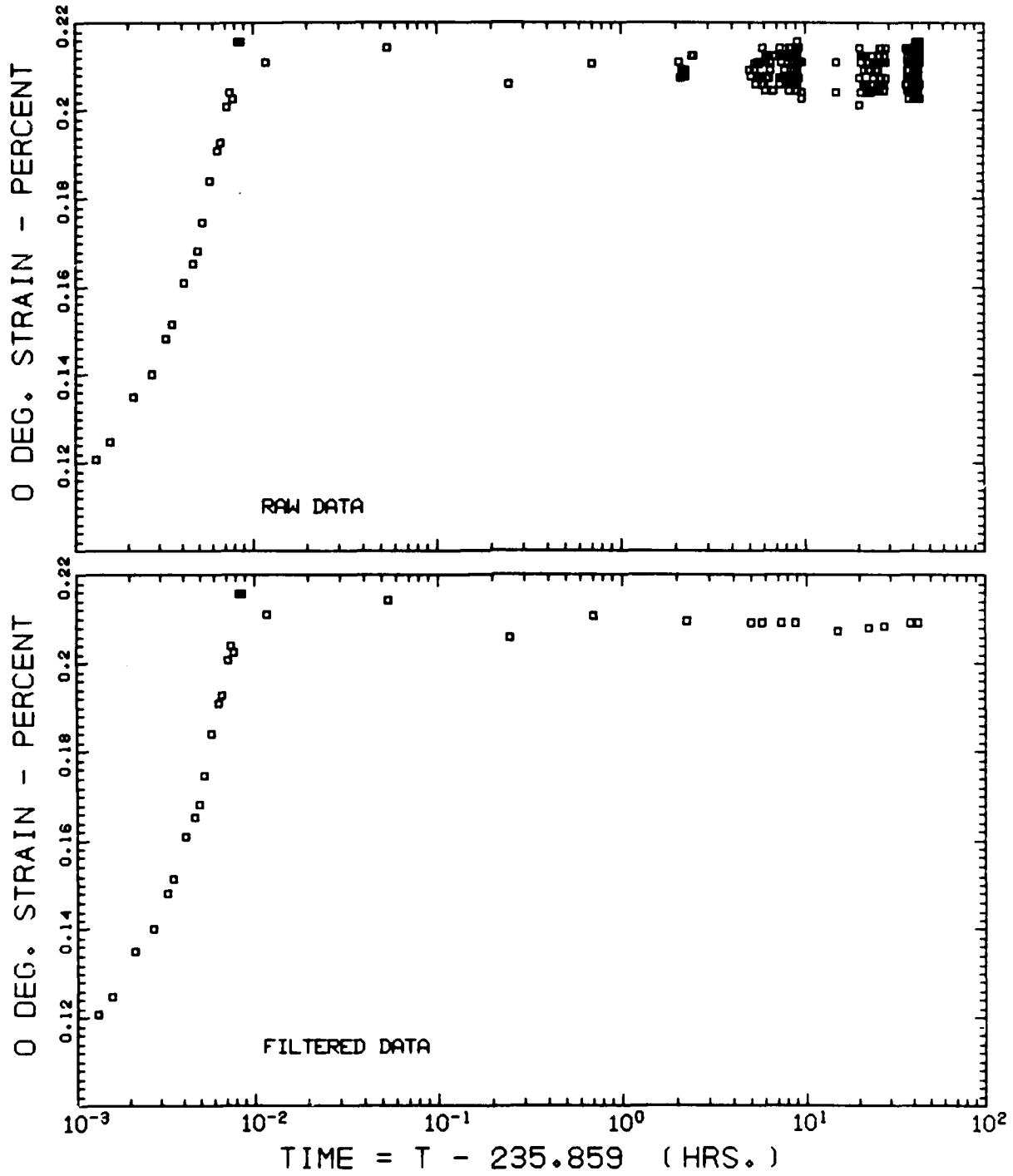

T300/5208 - STEP/RELAXATION - SPECIMEN No. 3 - STEP No. 6

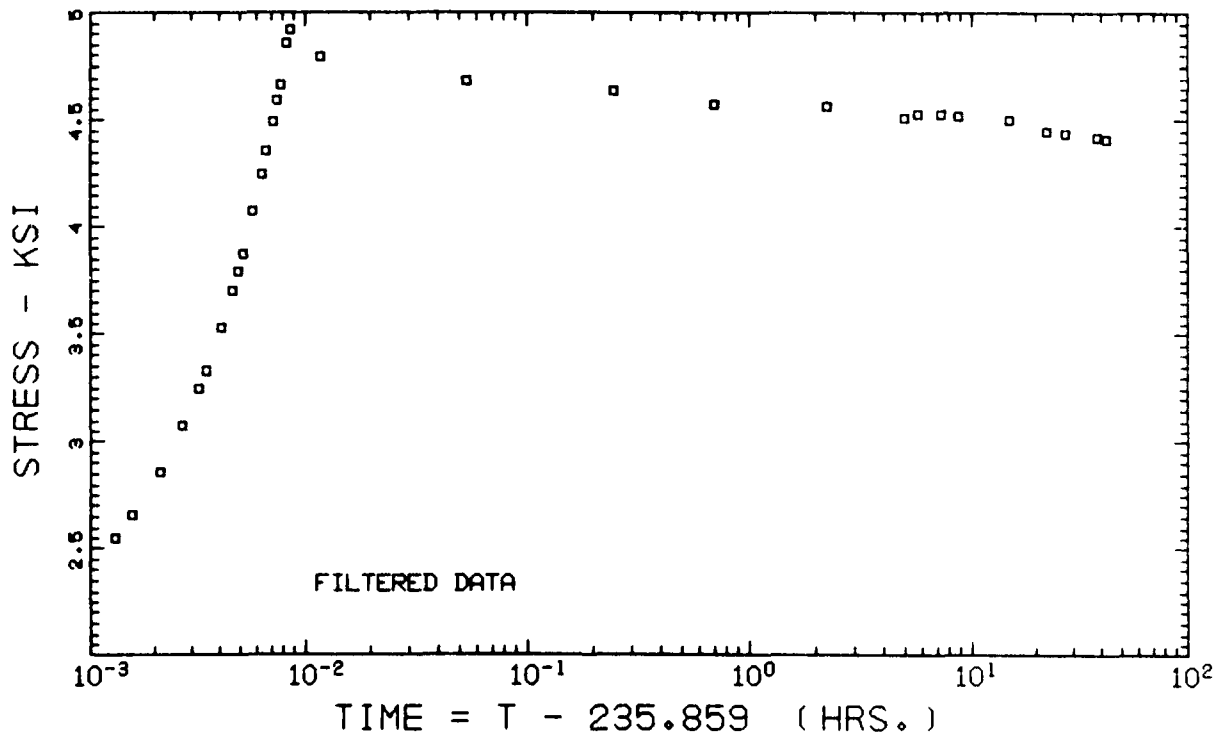
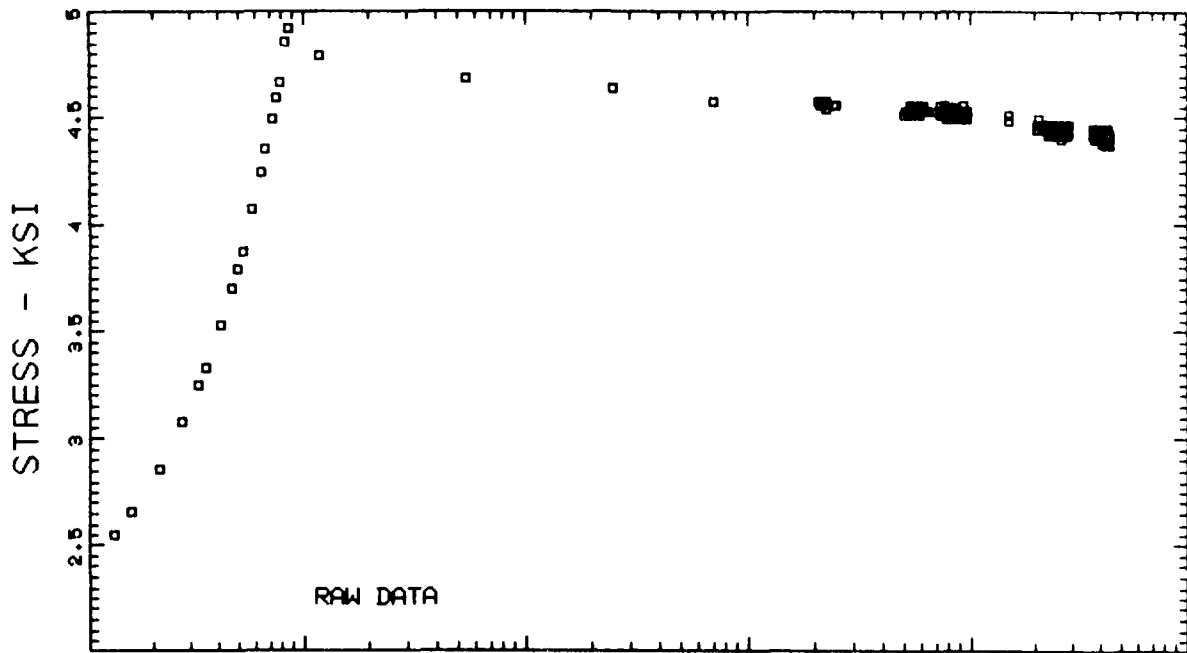

T300/5208 - STEP/RELAXATION - SPECIMEN No. 3 - STEP No. 6

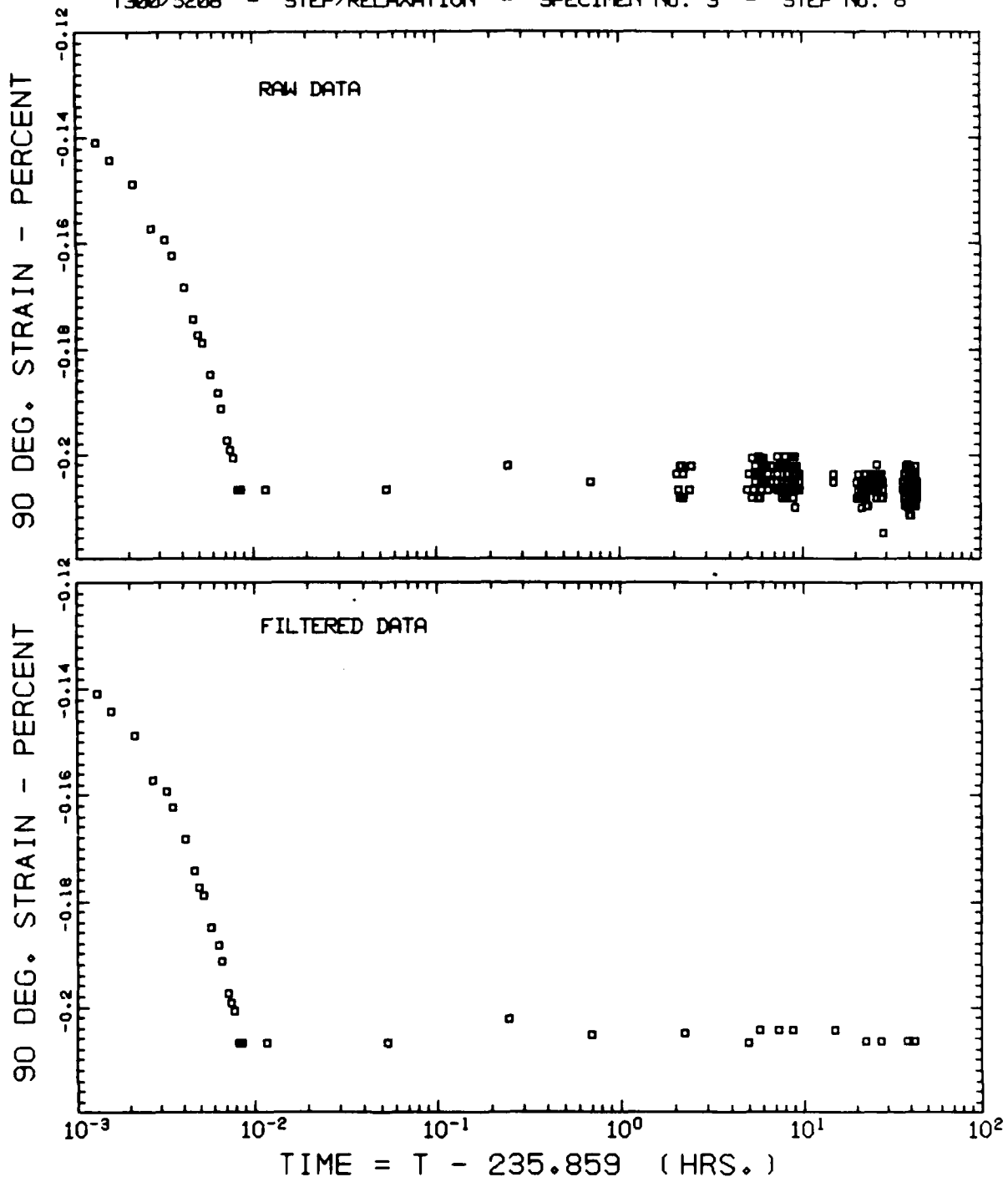

T300/5208 - STEP/RELAXATION - SPECIMEN No. 3 - STEP No. 7

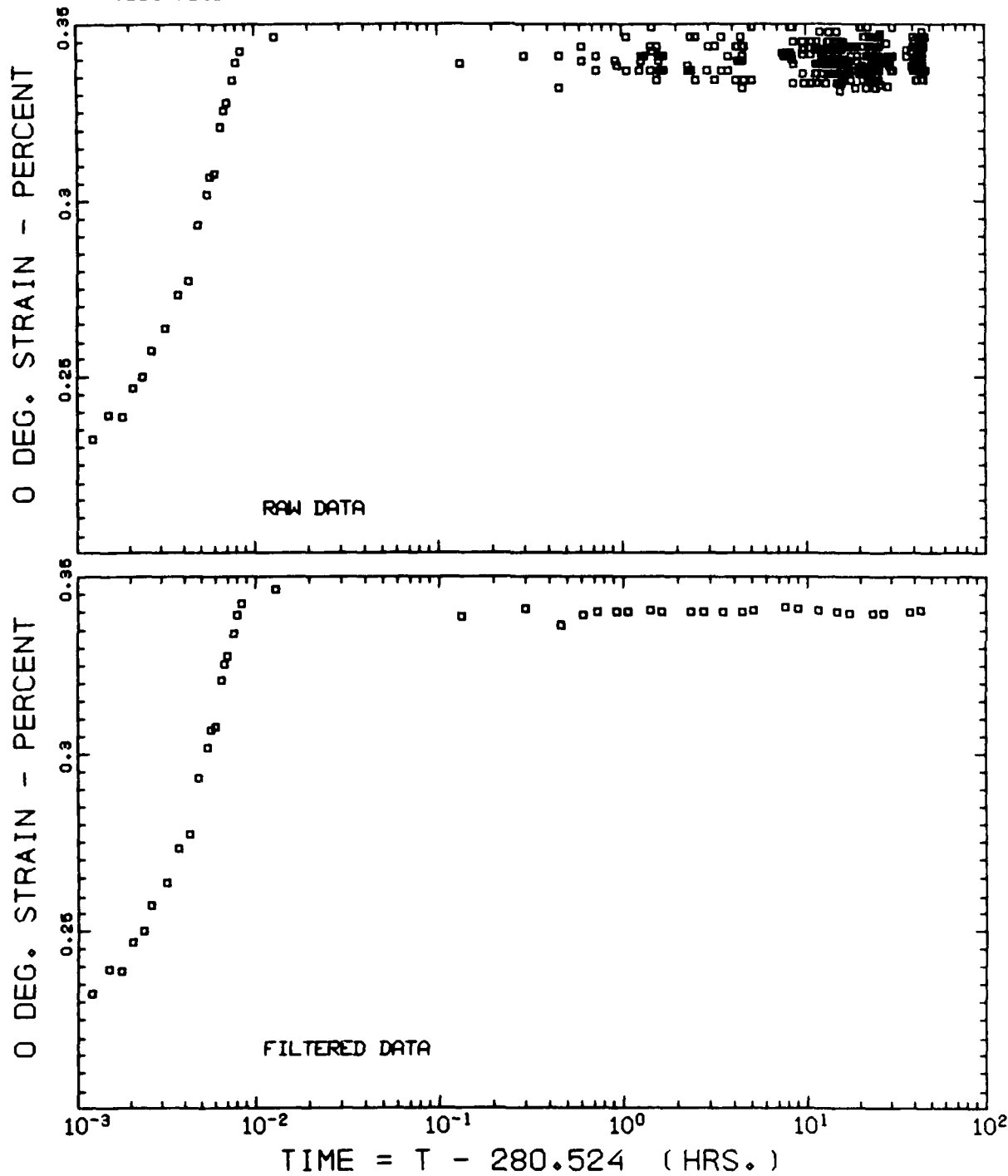



T300/S208 - STEP/RELAXATION - SPECIMEN No. 3 - STEP No. 7

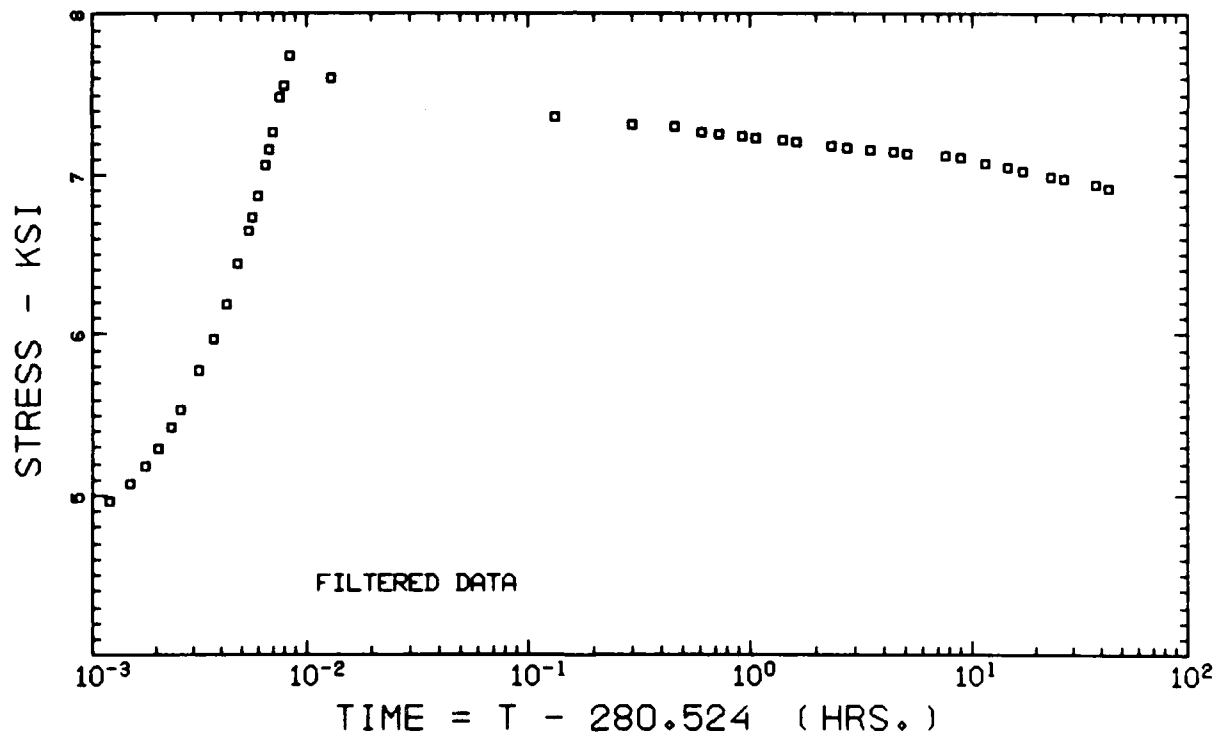
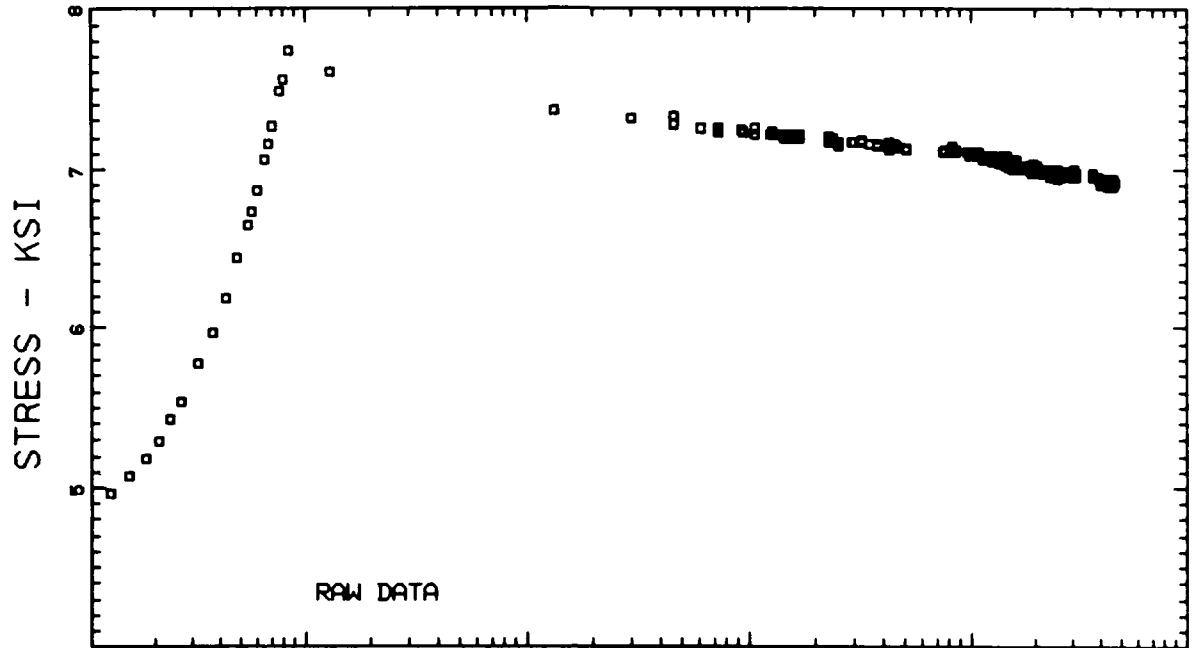

T300/5208 - STEP/RELAXATION - SPECIMEN No. 3 - STEP No. 7

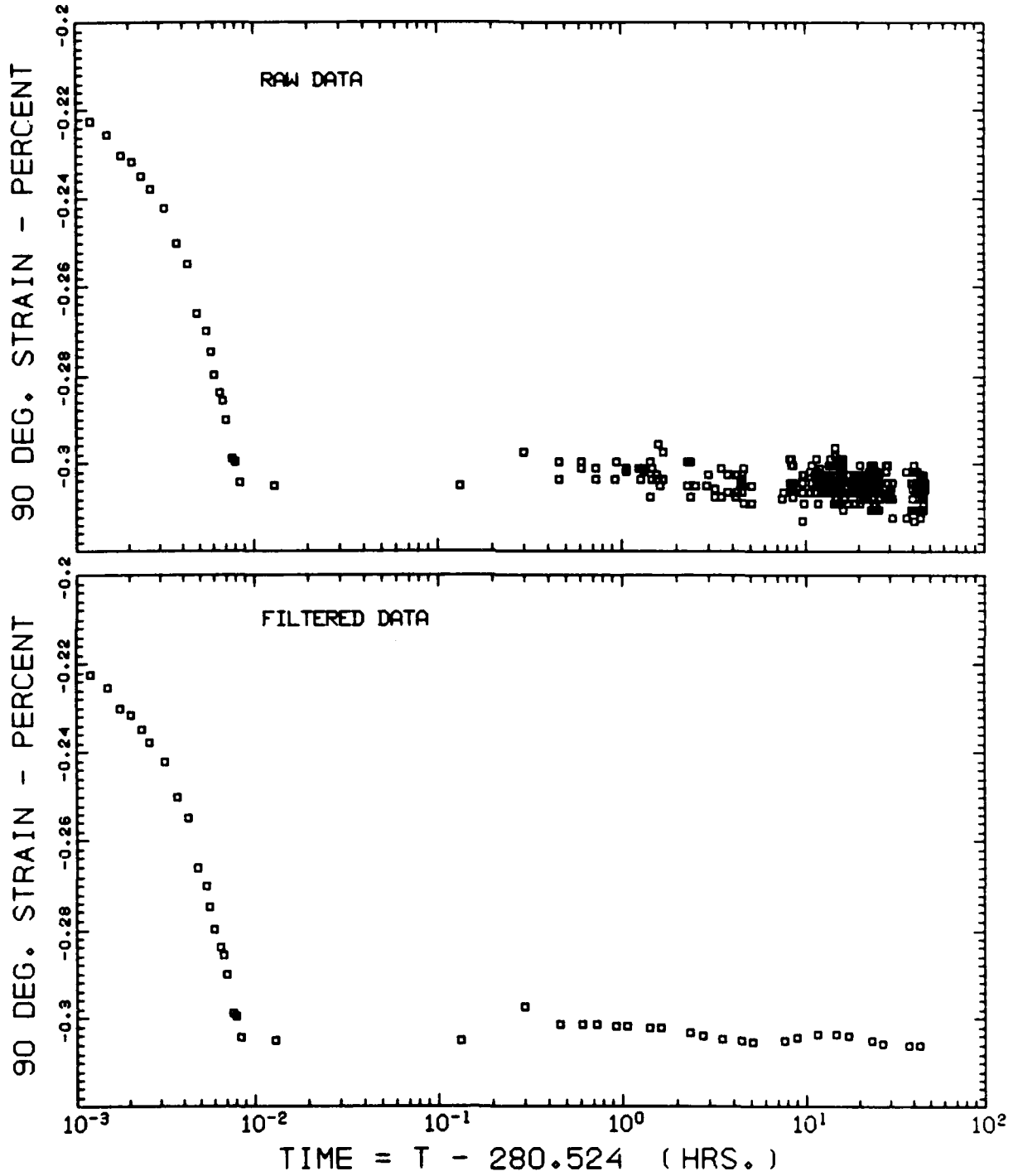

T300/5208 - STEP/RELAXATION - SPECIMEN No. 3 - STEP No. 8

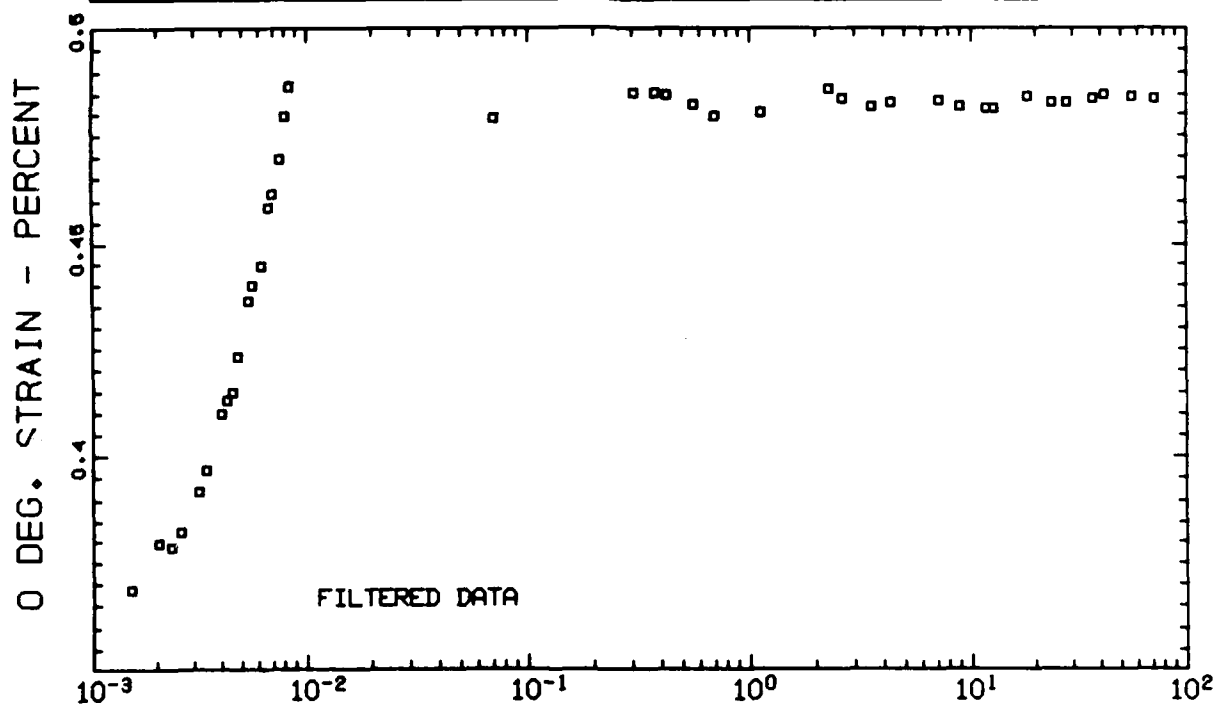
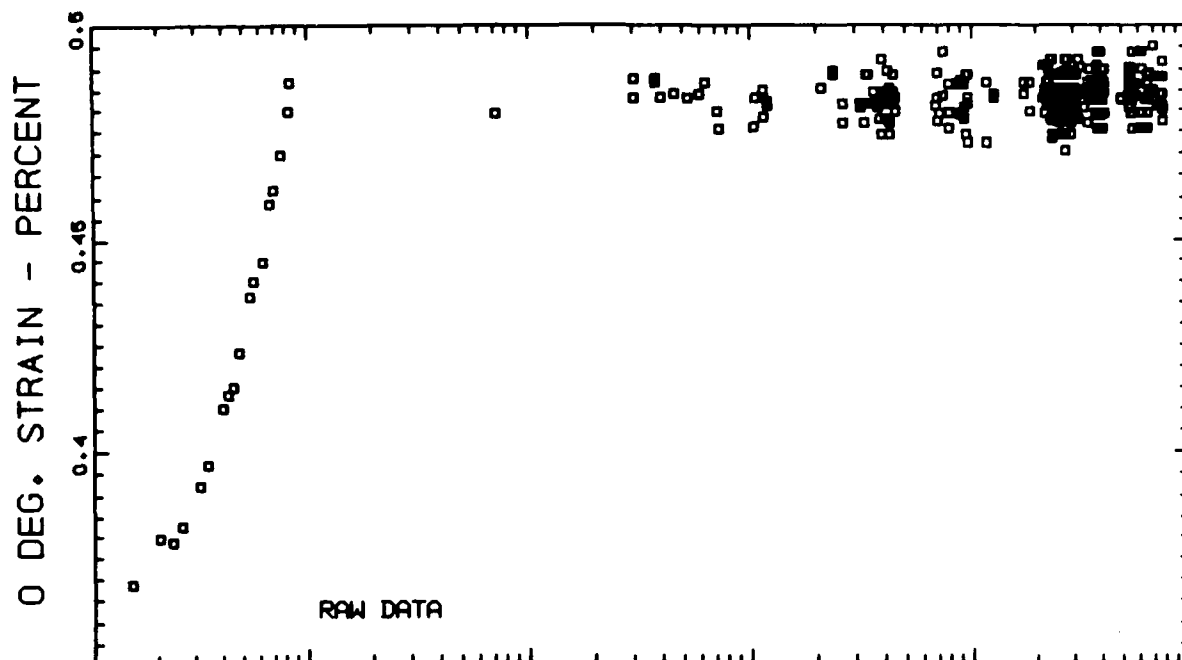

TIME = T - 327.828 (HRS.)

T300/5208 - STEP/RELAXATION - SPECIMEN No. 3 - STEP No. 8

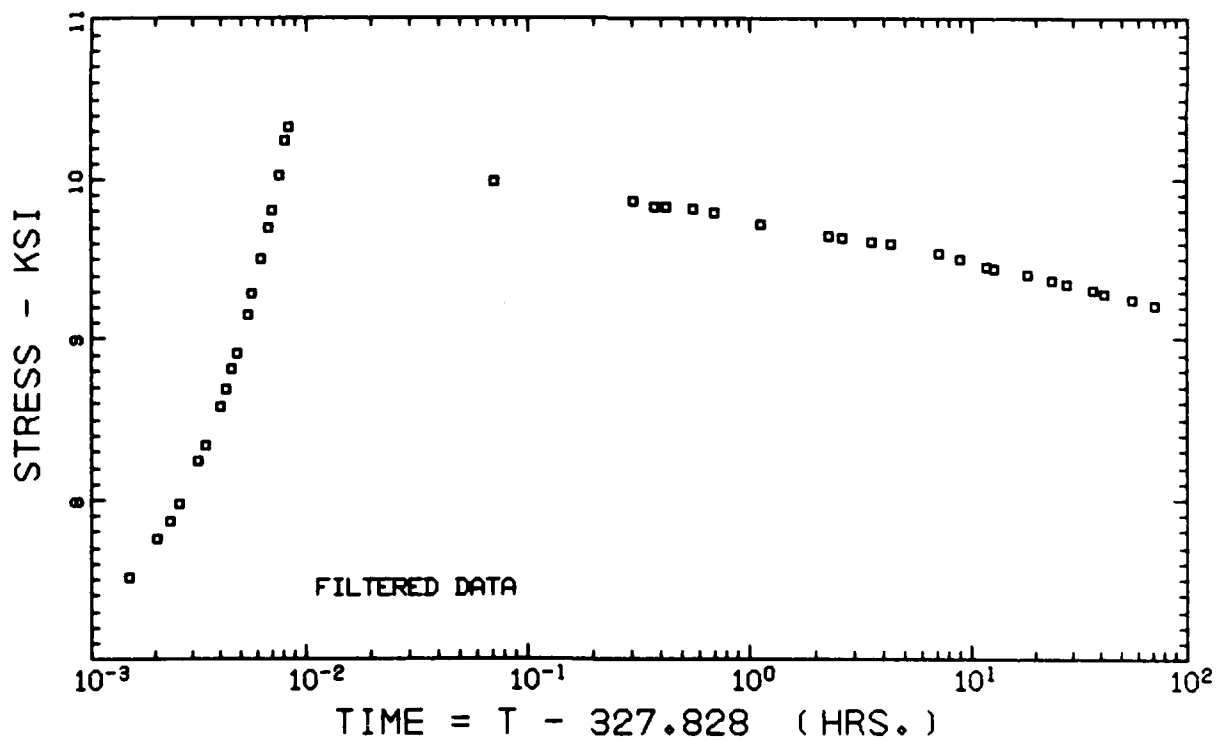
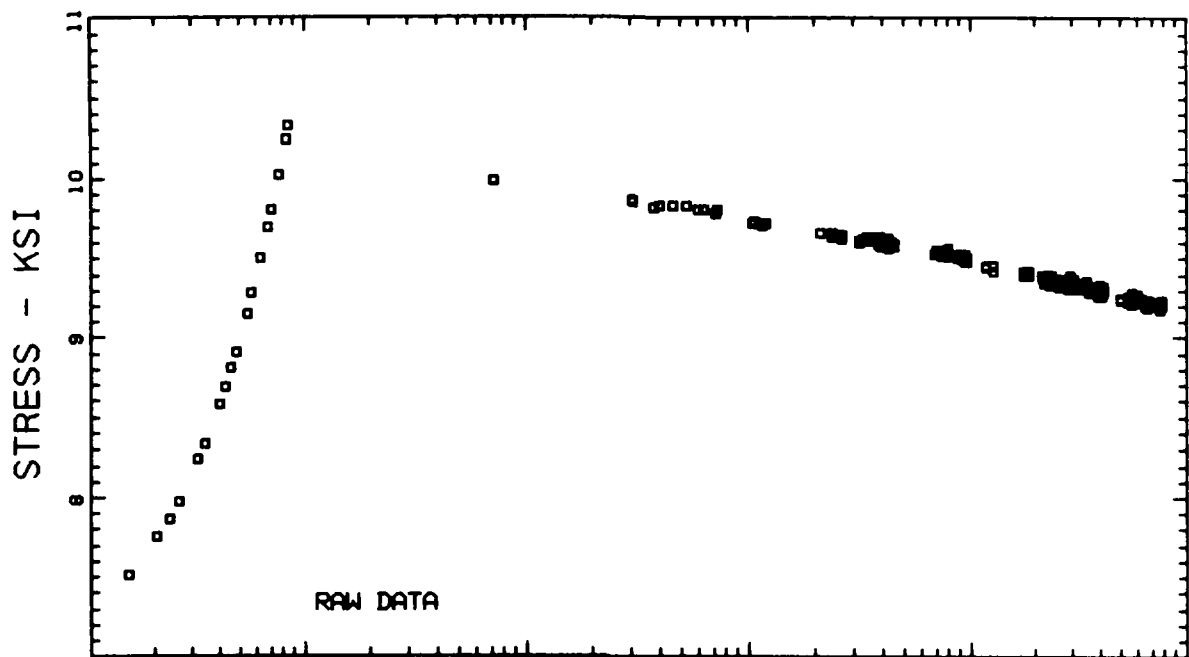

T300/5208 - STEP/RELAXATION - SPECIMEN No. 3 - STEP No. 8

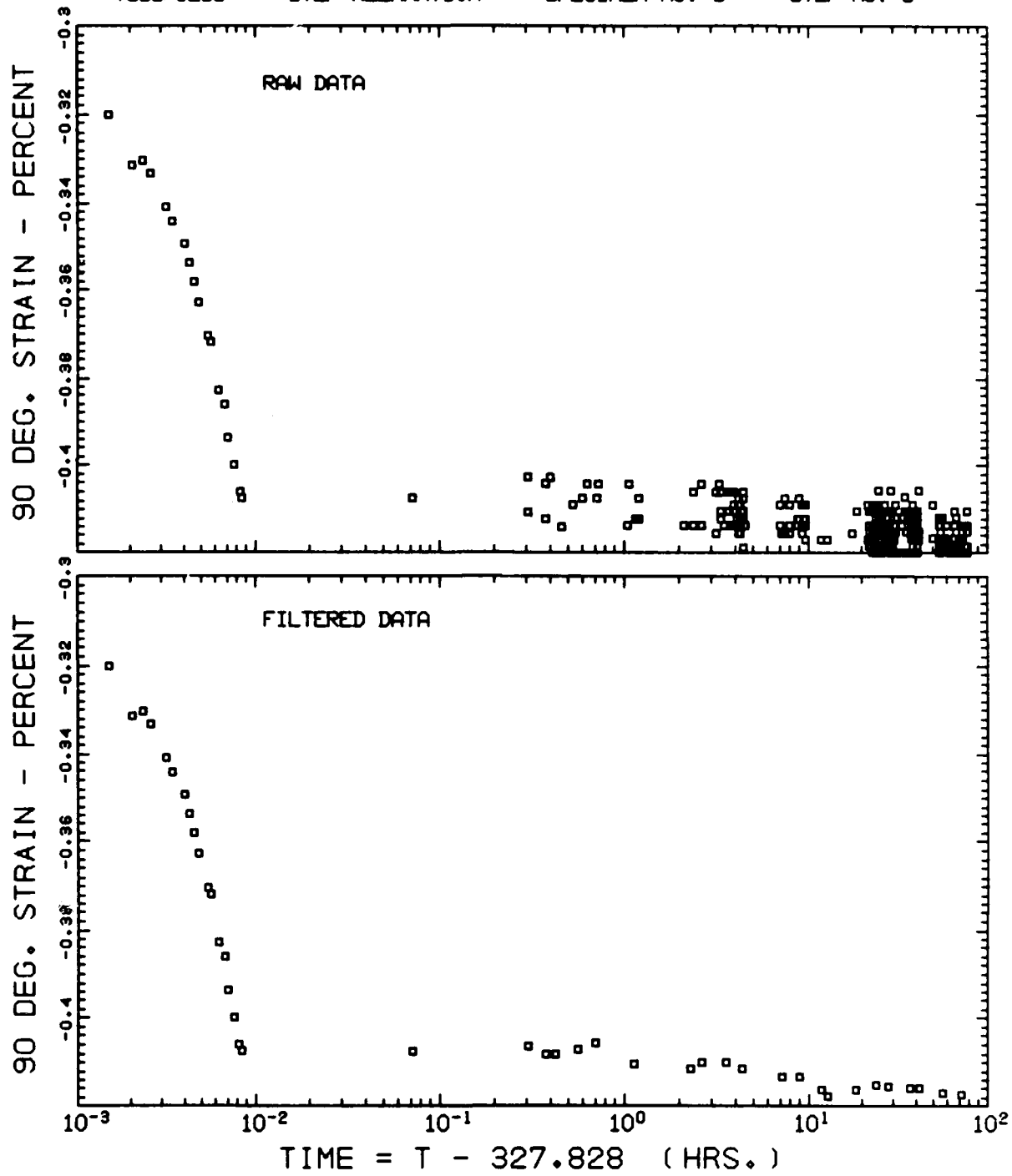

T300/5208 - STEP/RELAXATION - SPECIMEN No. 3 - STEP No. 9

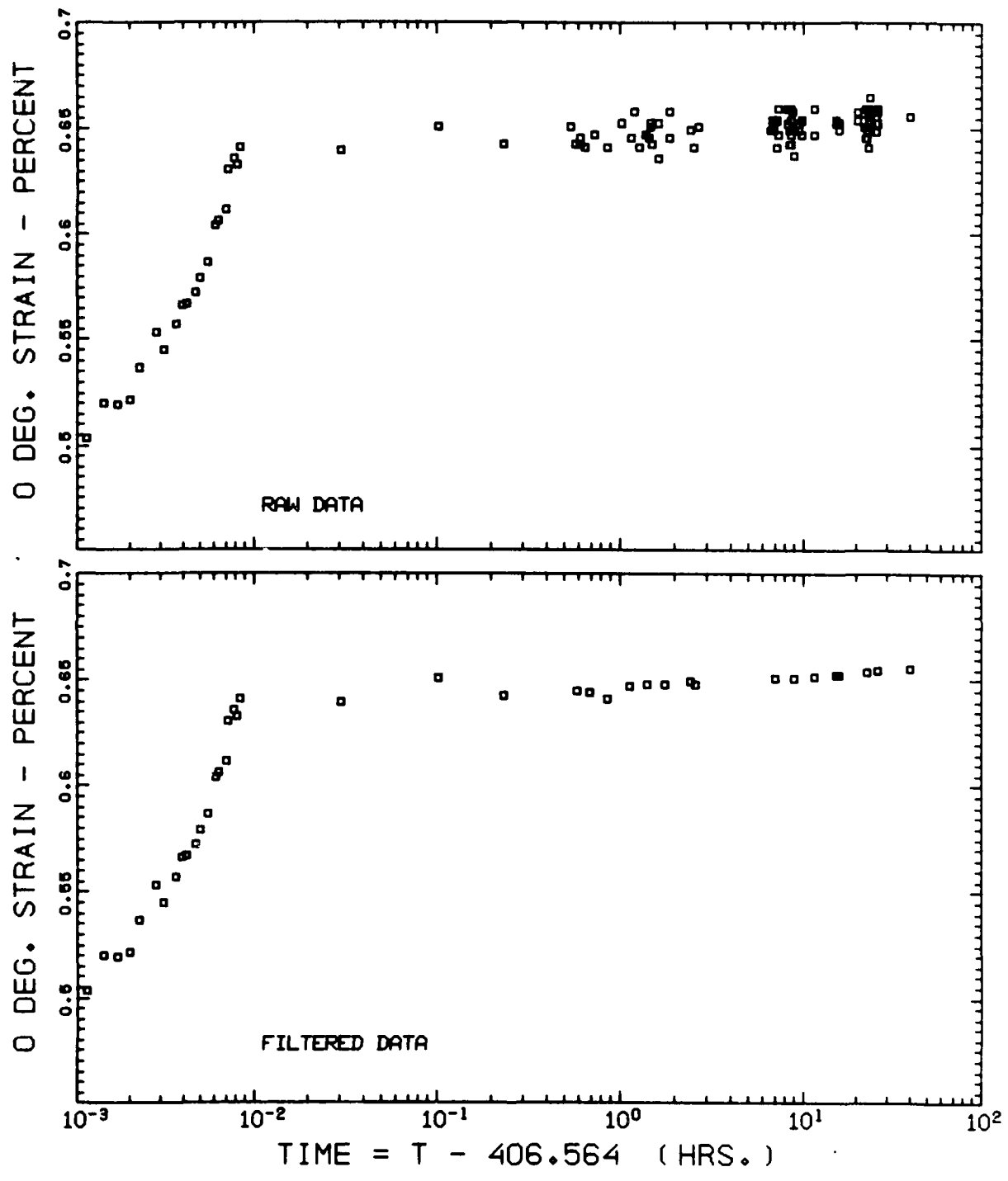

T300/5208 - STEP/RELAXATION - SPECIMEN No. 3 - STEP No. 9

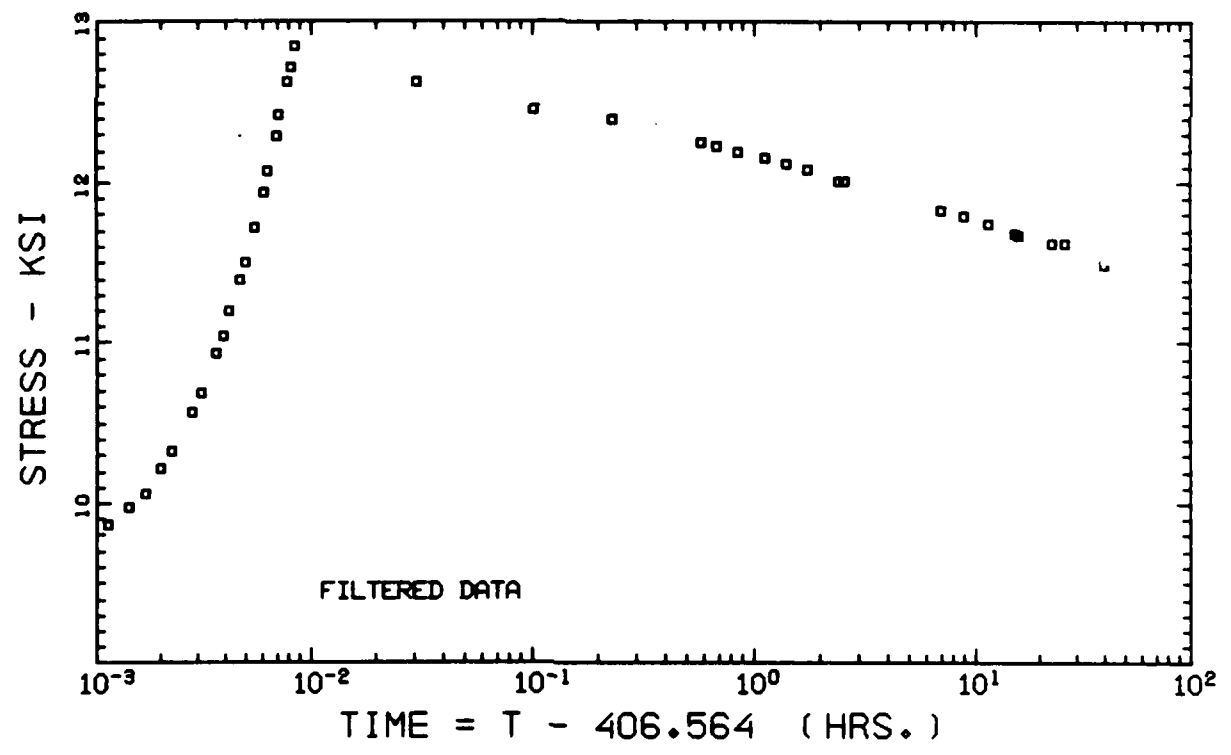
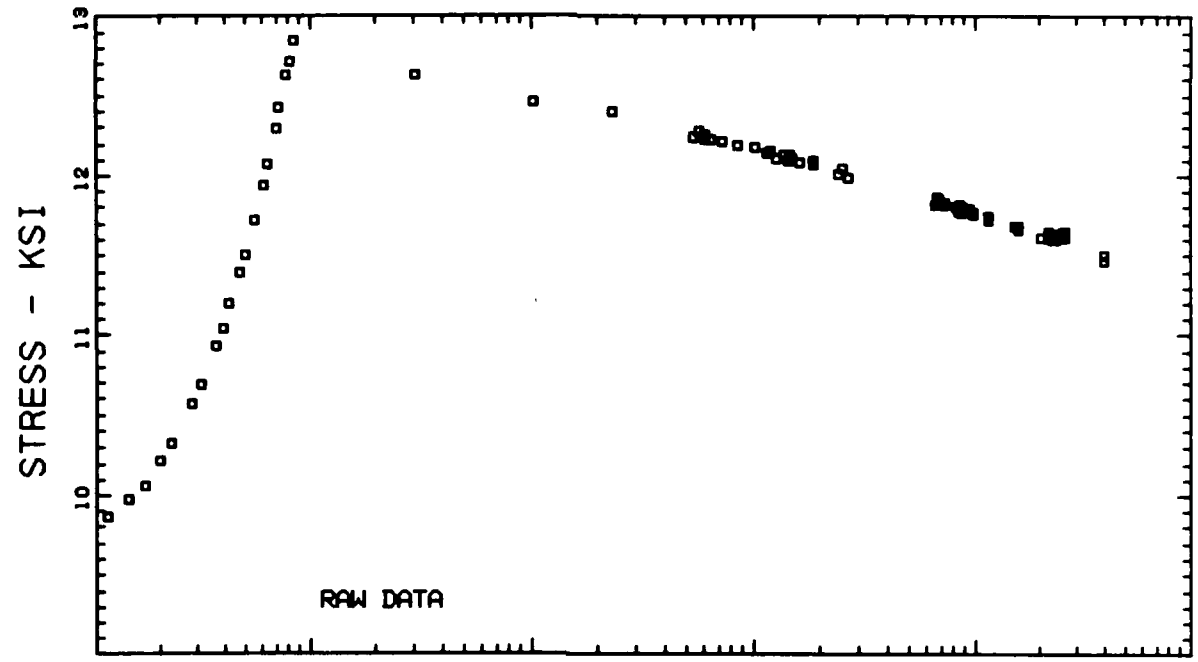

T300/5208 - STEP/RELAXATION - SPECIMEN No. 3 - STEP No. 9

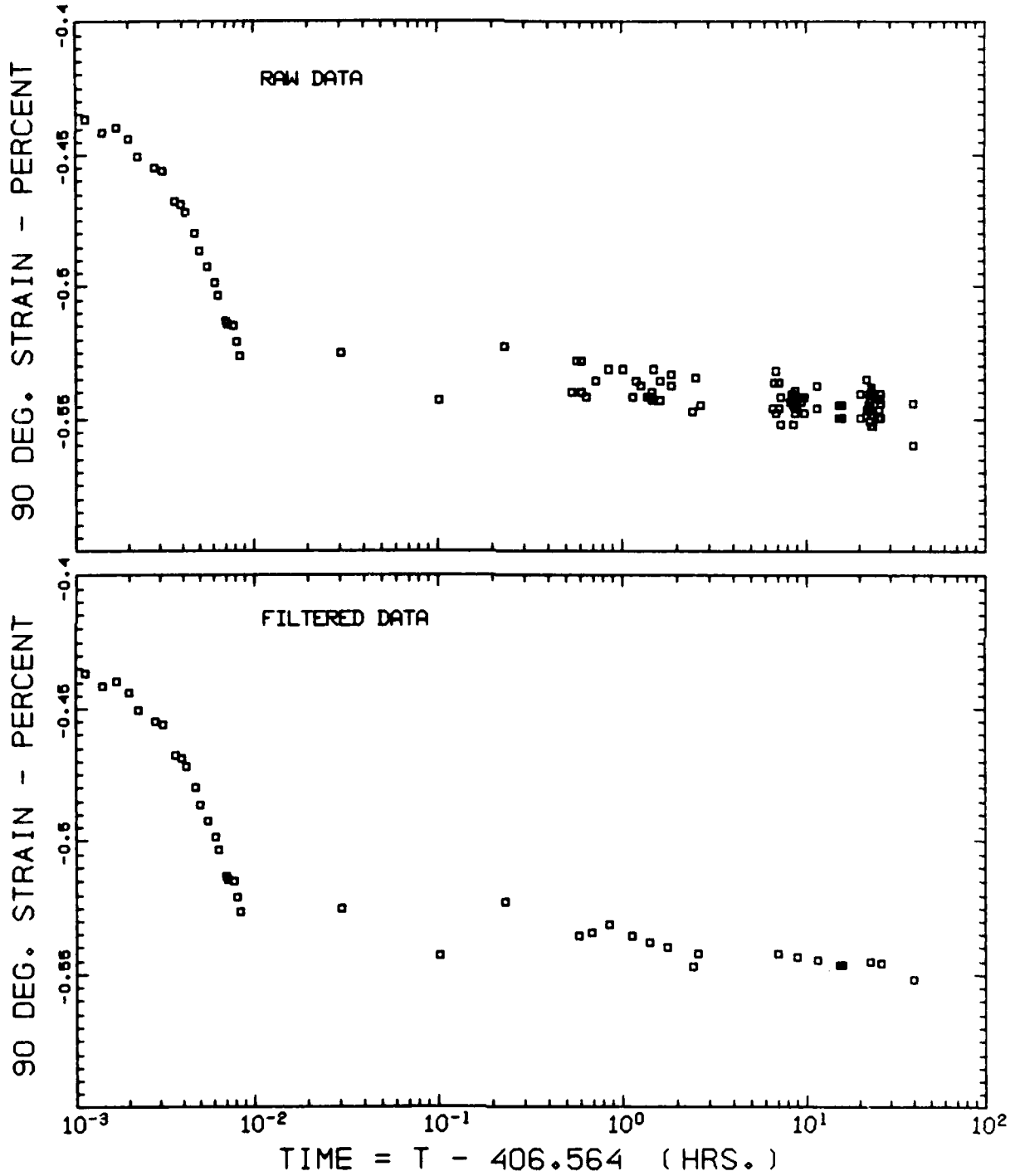



T300/5208 - STEP/RELAXATION - SPECIMEN NO. 4

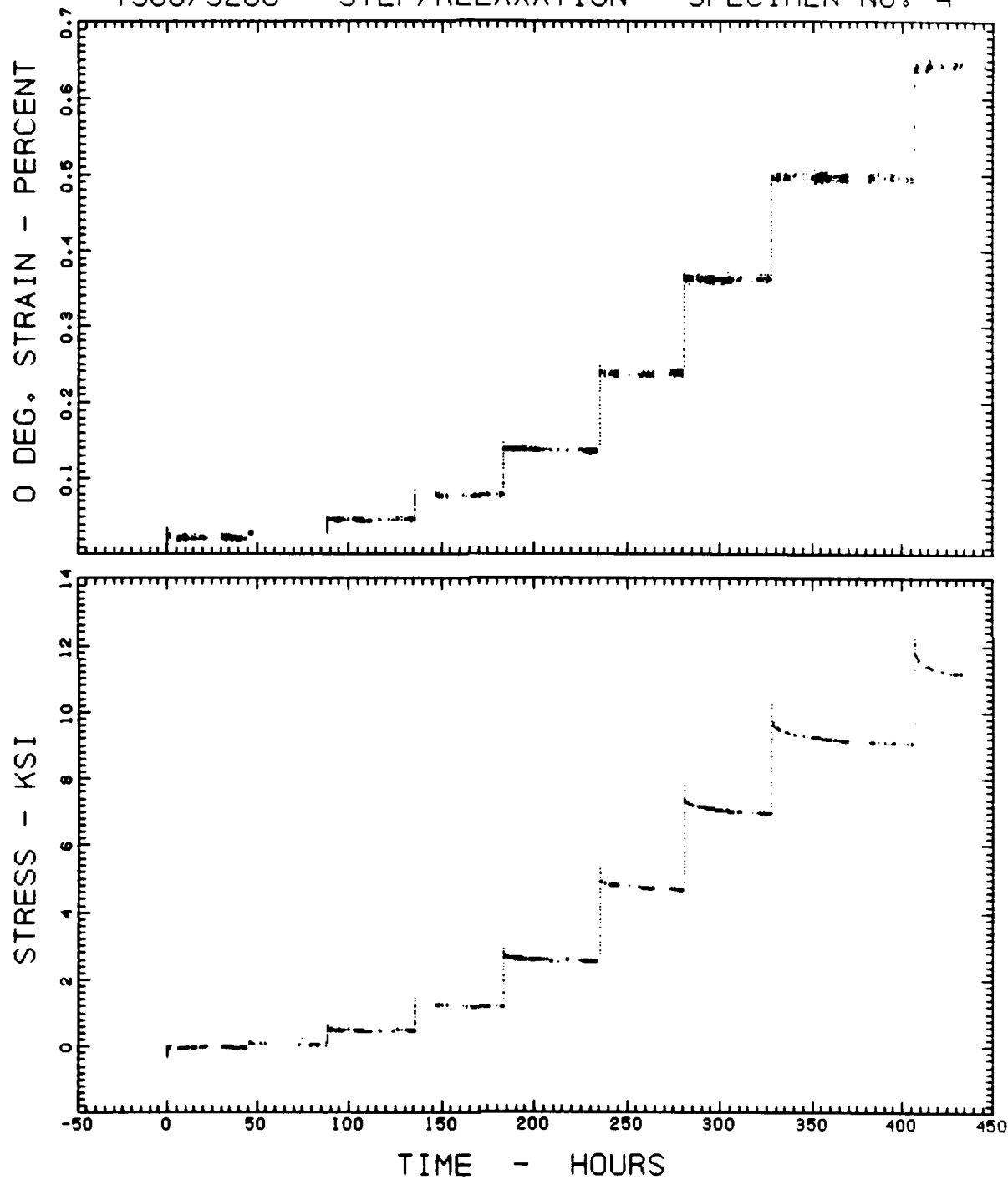

T300/5208 - STEP/RELAXATION - SPECIMEN NO. 4

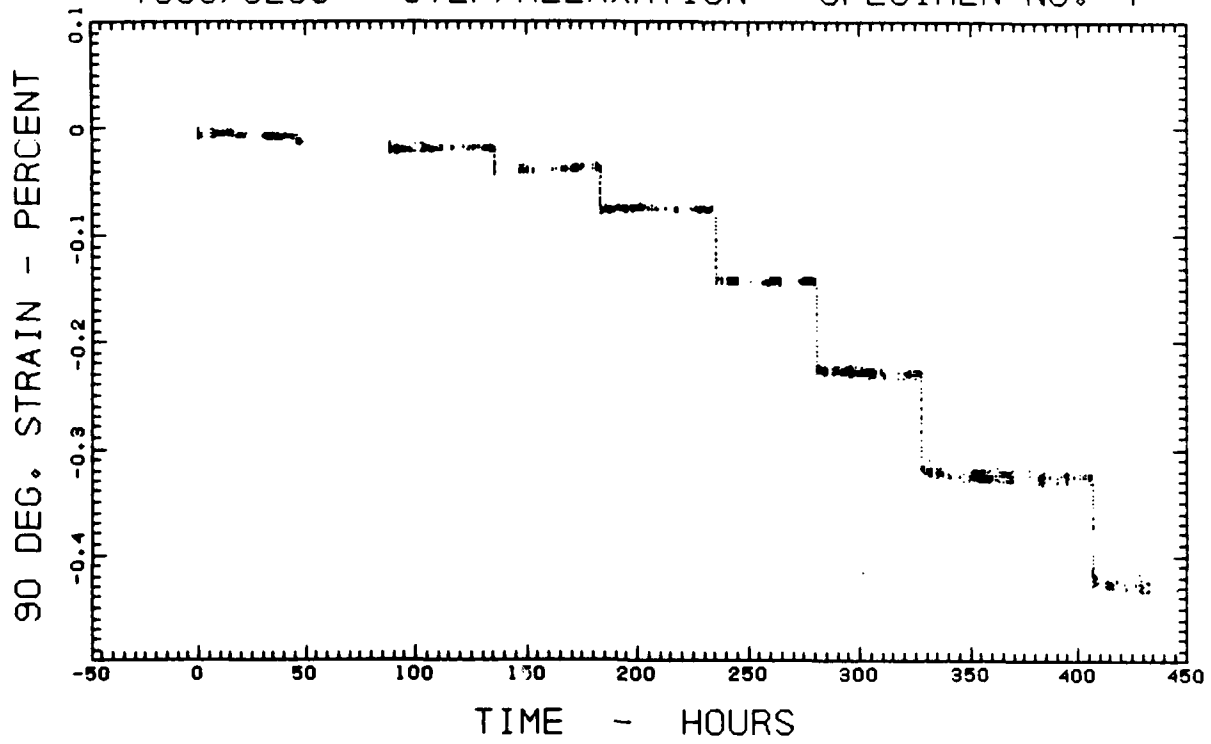

AD-A141 697

MATRIX-DOMINATED TIME-DEPENDENT DEFORMATION AND DAMAGE  
OF GRAPHITE EPOXY. (U) LAWRENCE LIVERMORE NATIONAL LAB  
CA E M WU ET AL. MAY 83 UCID-19765 AFAL-TR-83-3056  
N-7405-ENG-48

2/6

UNCLASSIFIED

F/G 11/9

NL

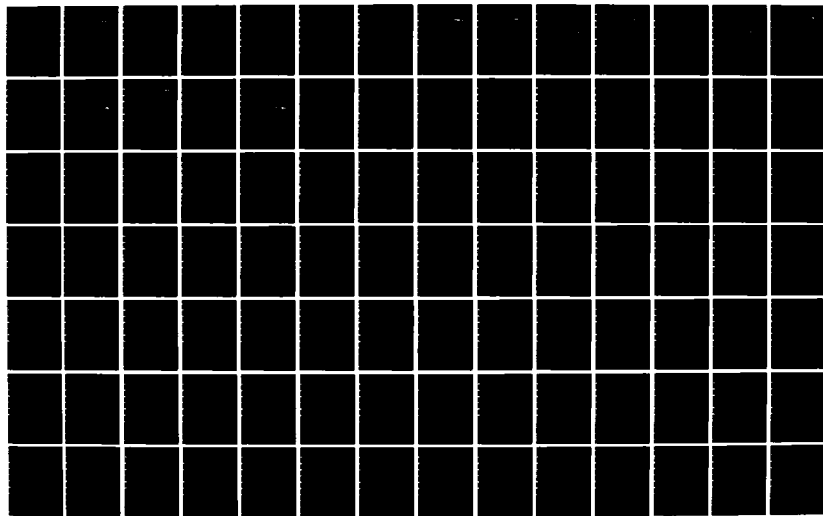

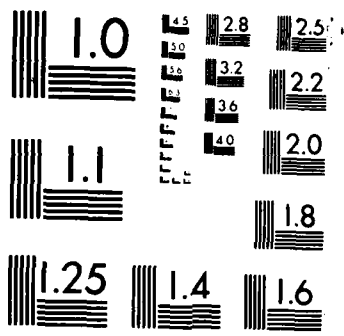

MICROCOPY RESOLUTION TEST CHART  
NATIONAL BUREAU OF STANDARDS 1963-A

T300-5208 - STEP/RELAXATION - SPECIMEN No. 4 - STEP No. 3

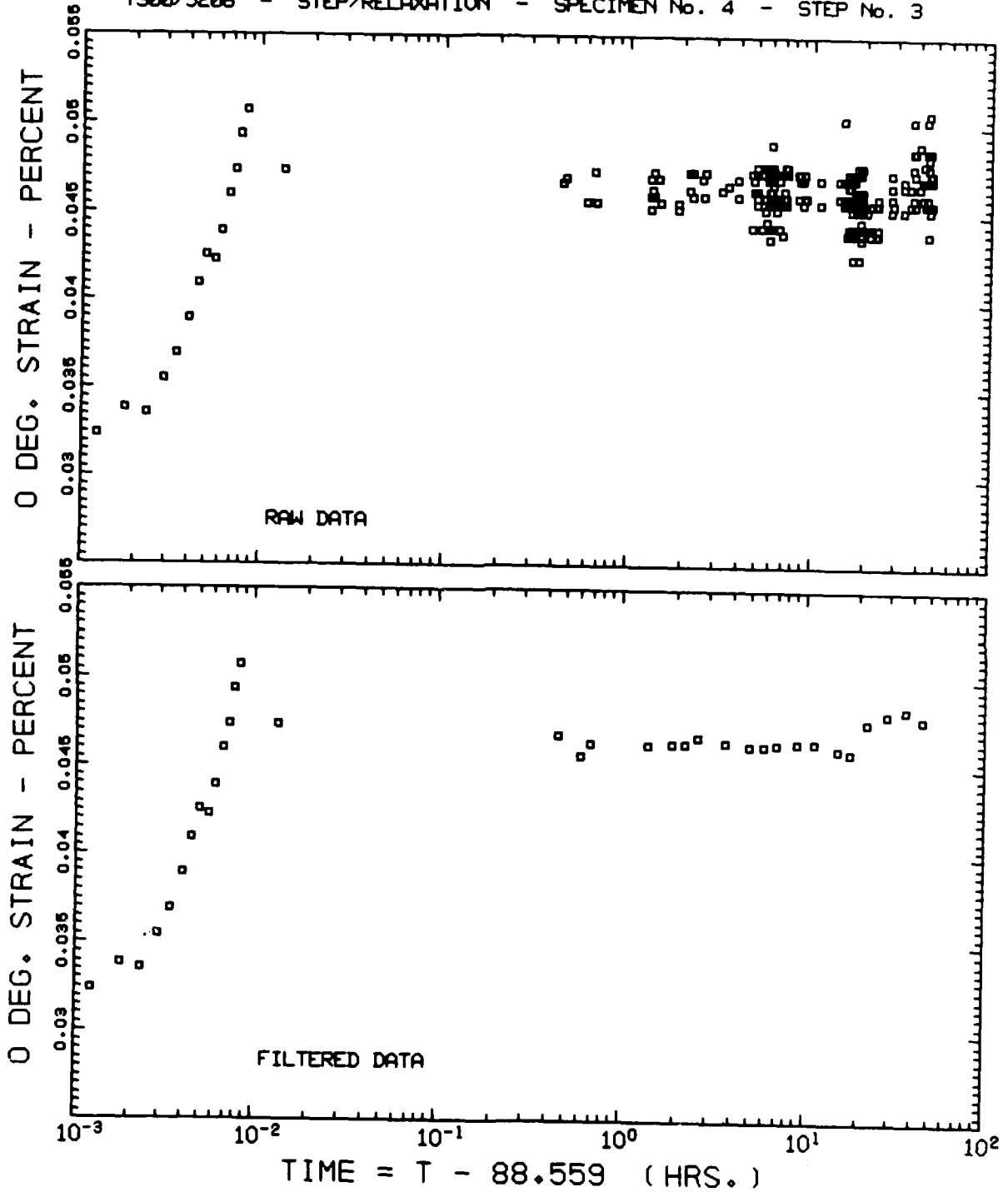

T300/5208 - STEP/RELAXATION - SPECIMEN No. 4 - STEP No. 3

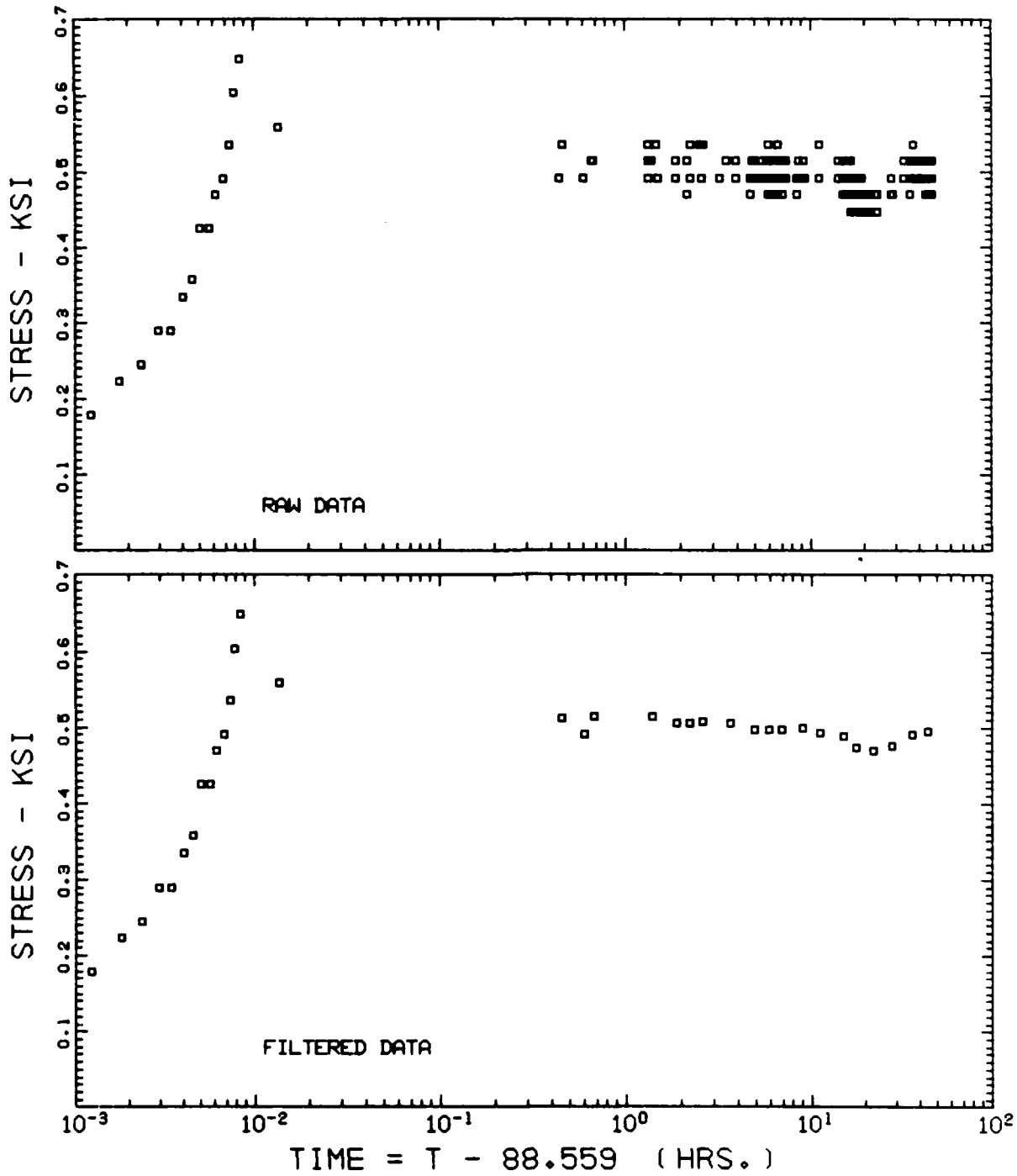

T300/5208 - STEP/RELAXATION - SPECIMEN No. 4 - STEP No. 3

90 DEG. STRAIN - PERCENT

90 DEG. STRAIN - PERCENT

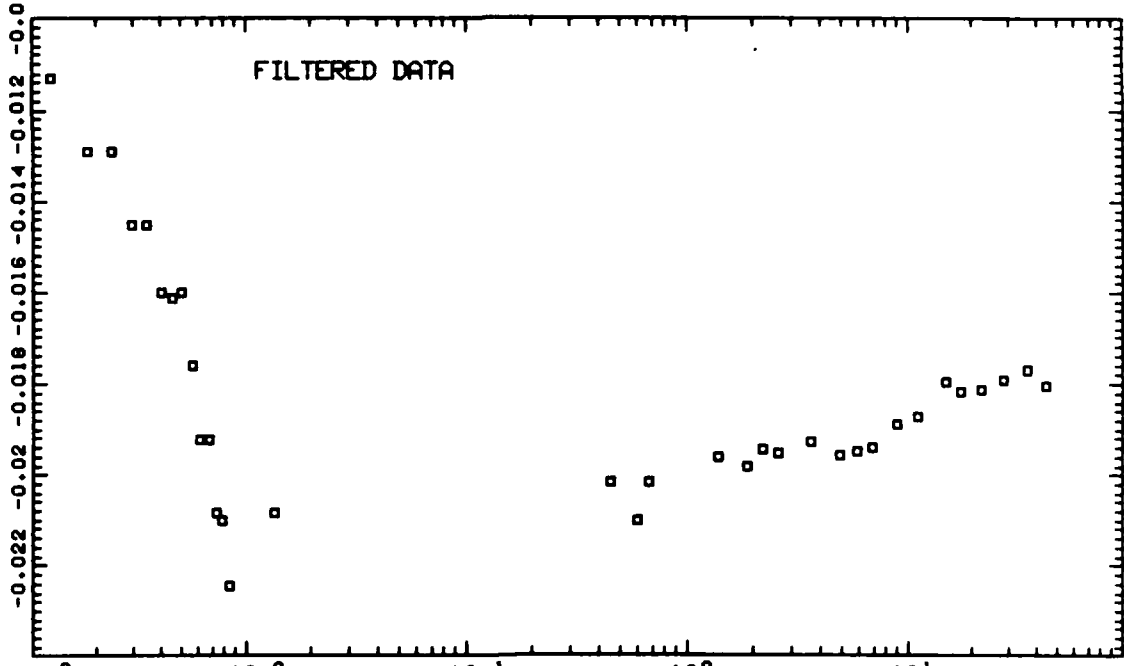
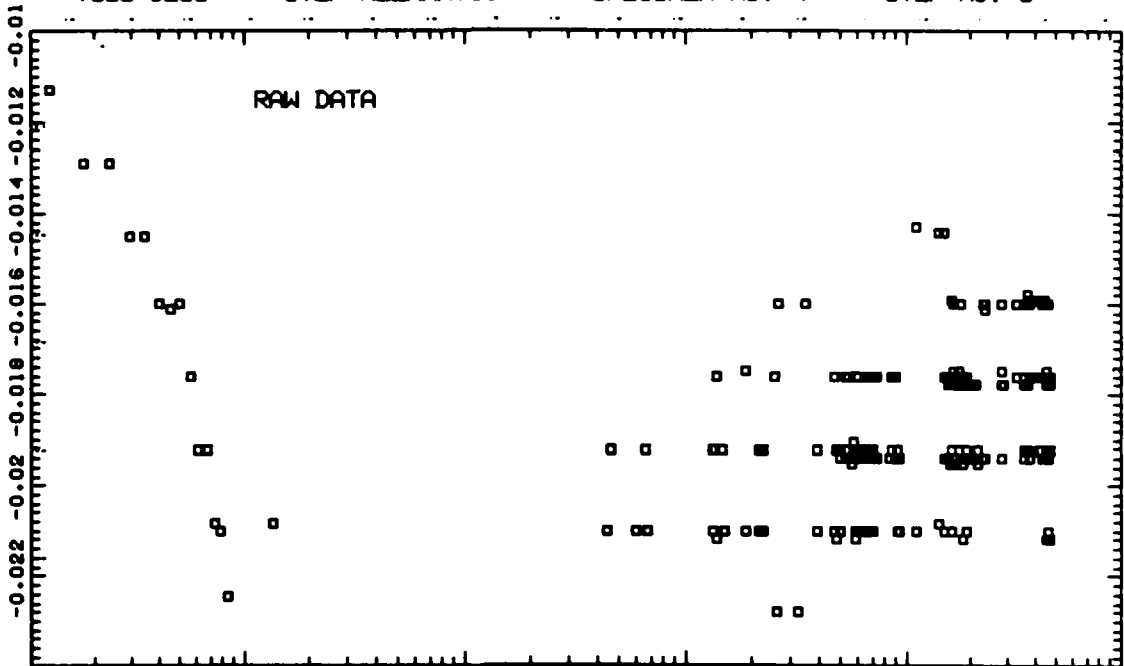

TIME = T - 88.559 (HRS.)

T300/5208 - STEP/RELAXATION - SPECIMEN No. 4 - STEP No. 4

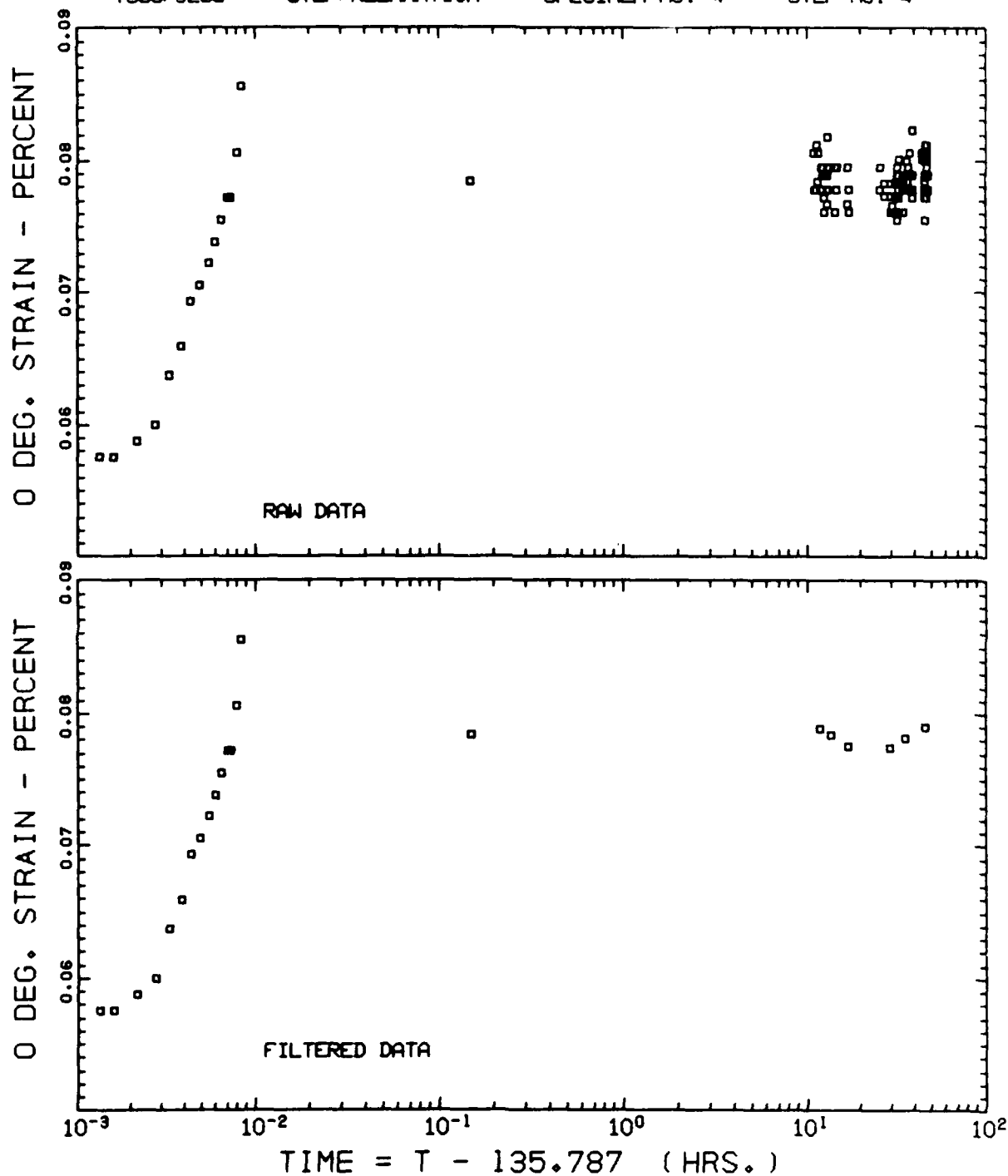



T300/5208 - STEP/RELAXATION - SPECIMEN No. 4 - STEP No. 4

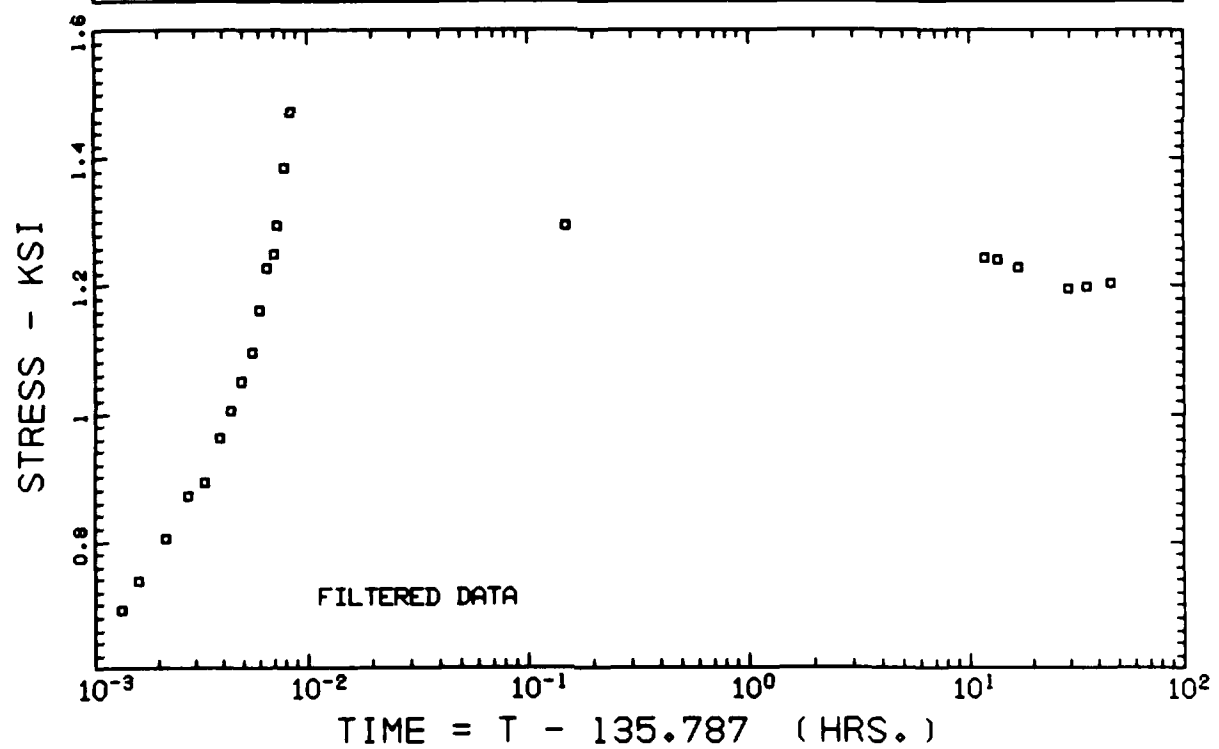
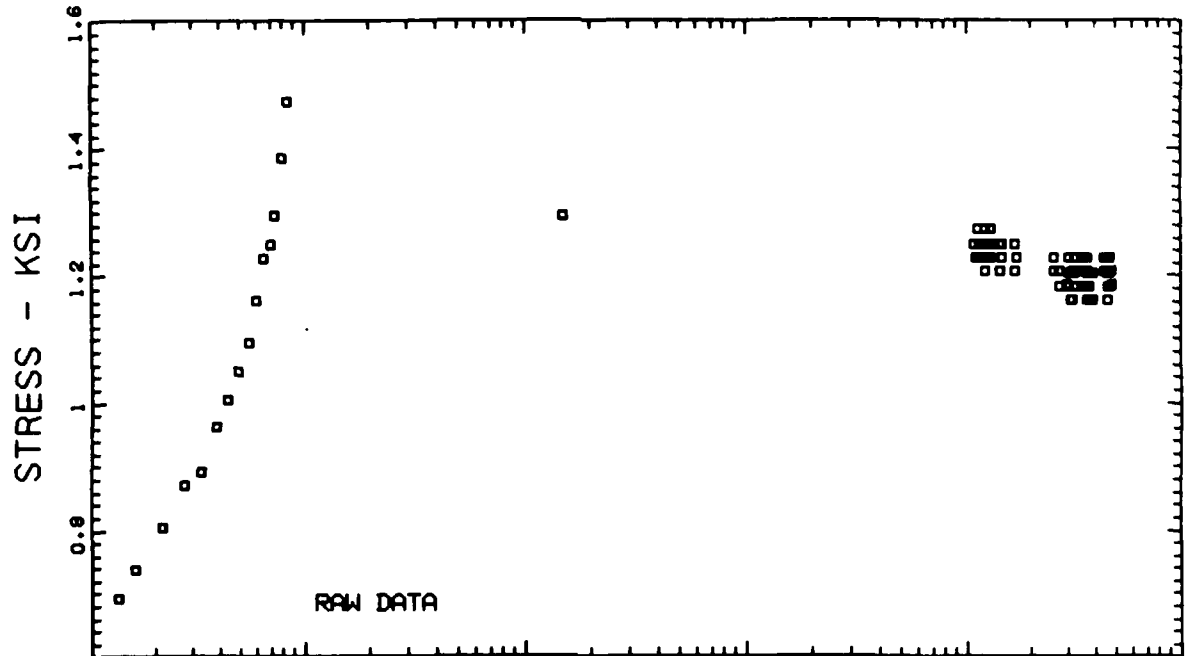

T300/5208 - STEP/RELAXATION - SPECIMEN No. 4 - STEP No. 4

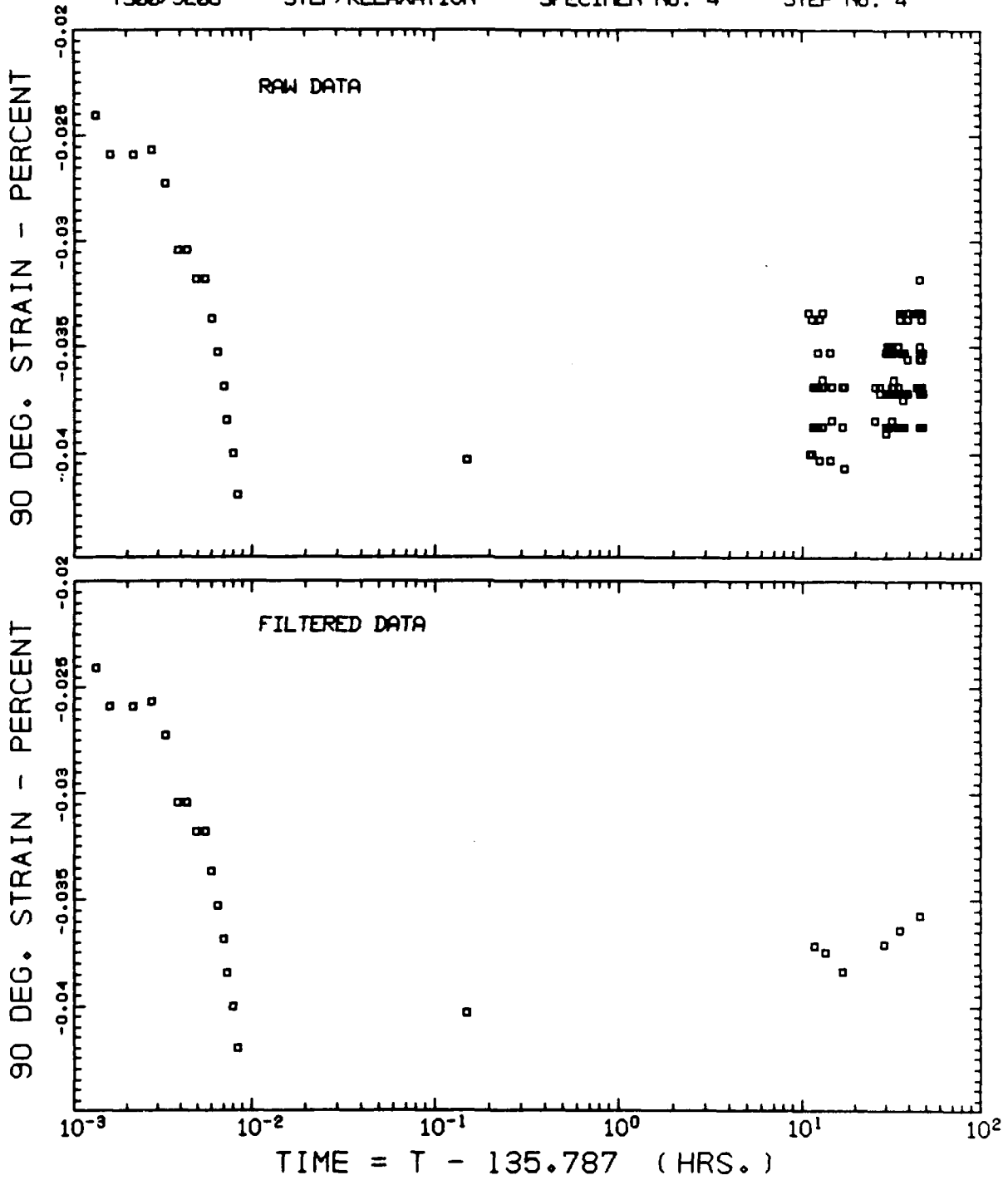

T300/5208 - STEP/RELAXATION - SPECIMEN No. 4 - STEP No. 5

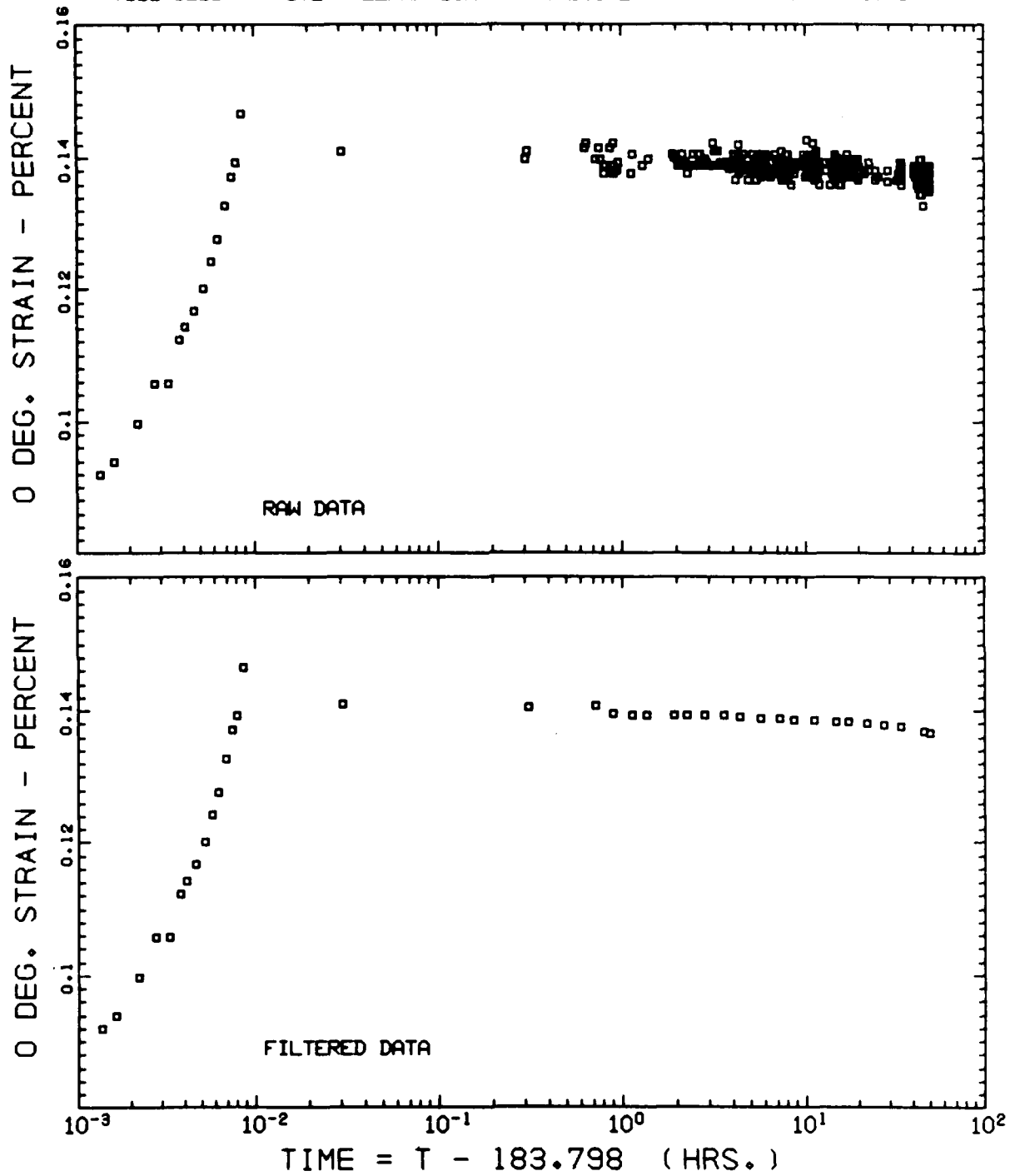

T300/5208 - STEP/RELAXATION - SPECIMEN No. 4 - STEP No. 5

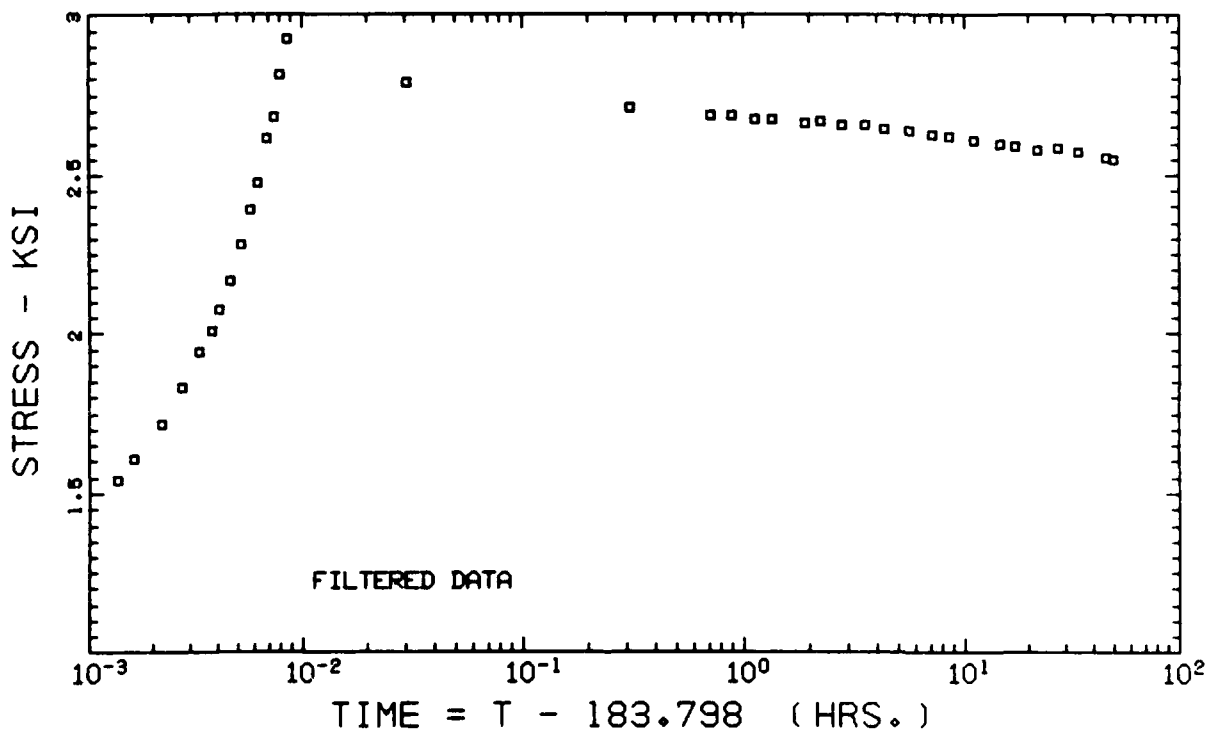
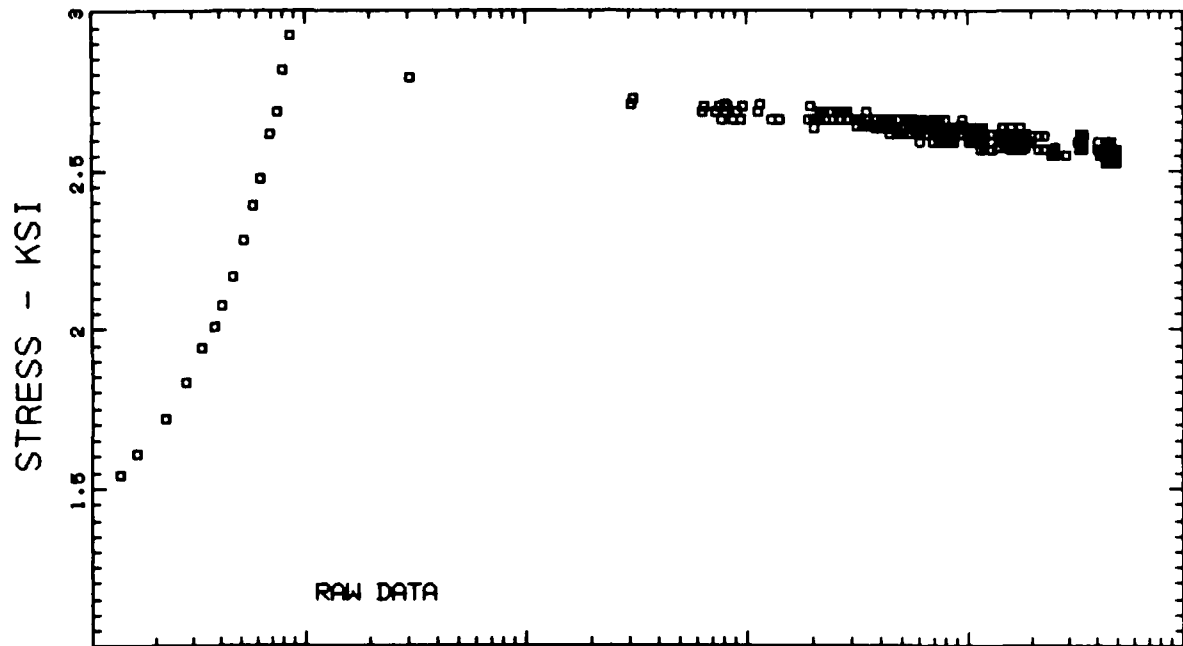

T300/5208 - STEP/RELAXATION - SPECIMEN No. 4 - STEP No. 5

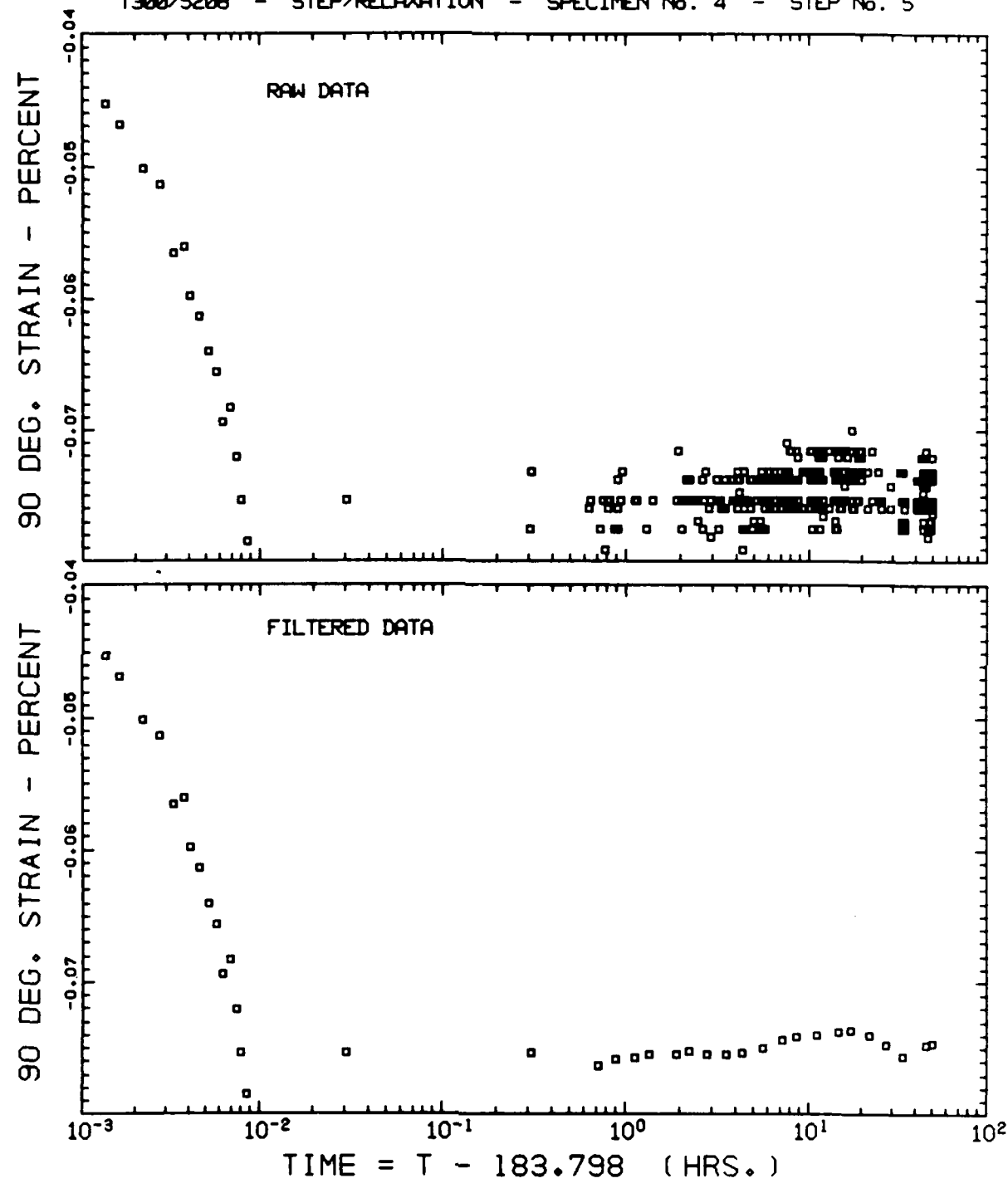

T300/5208 - STEP/RELAXATION - SPECIMEN No. 4 - STEP No. 6

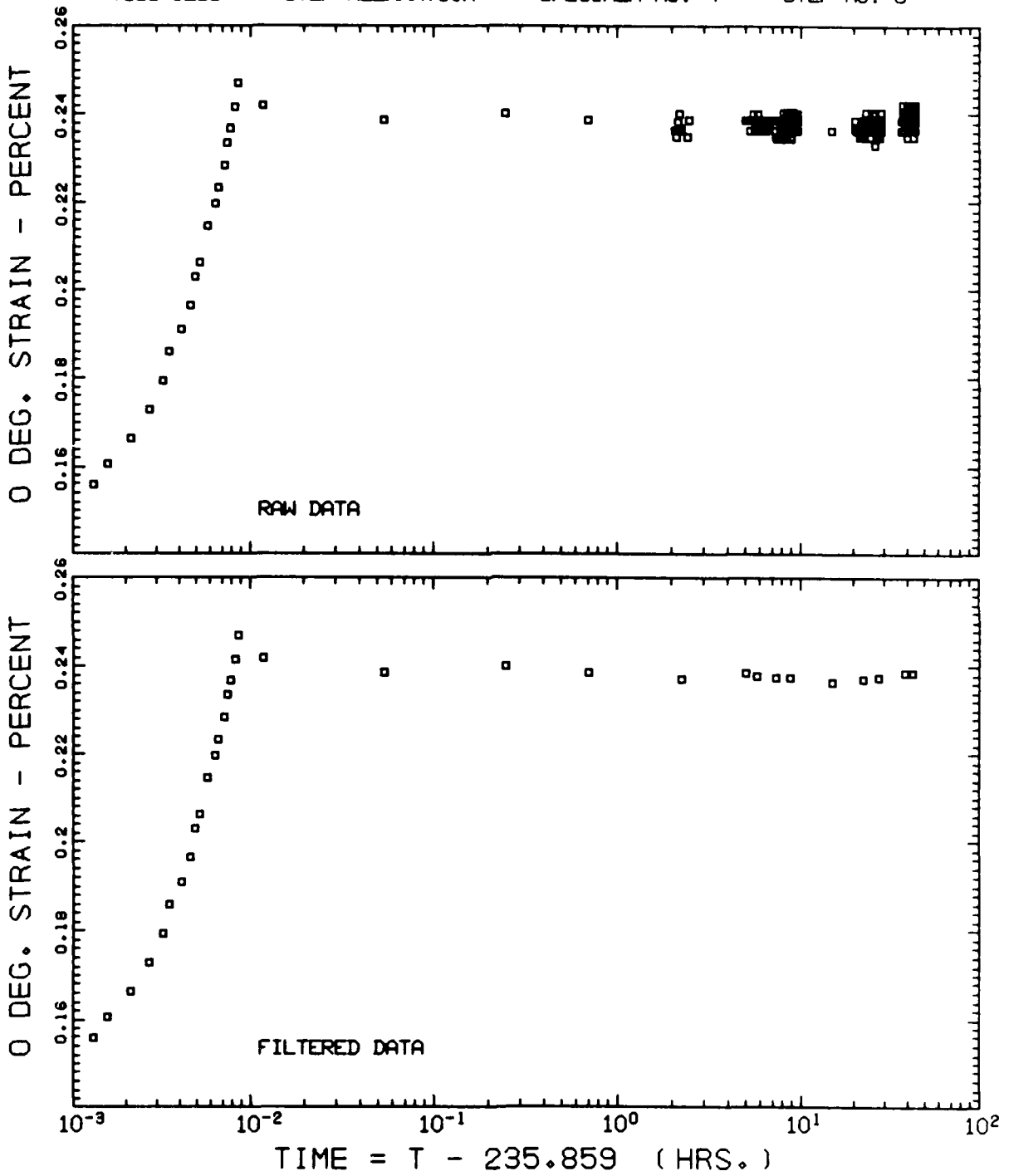

T300/5208 - STEP/RELAXATION - SPECIMEN No. 4 - STEP No. 6

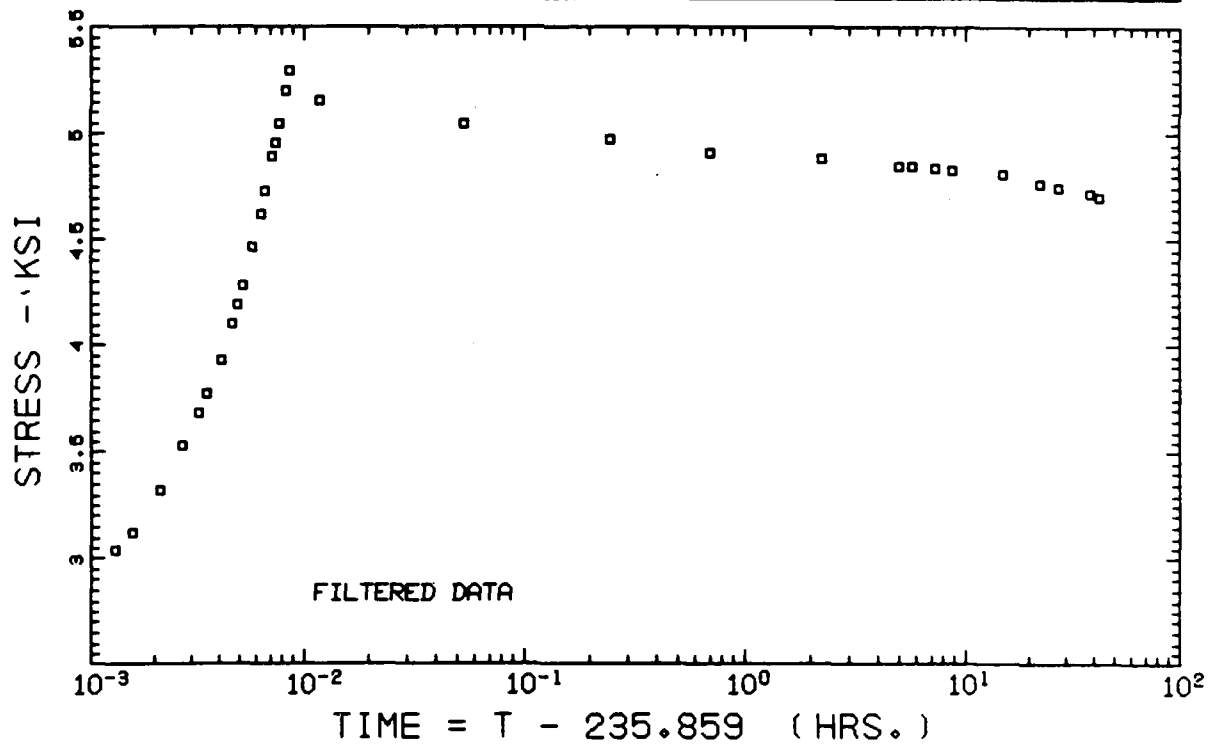
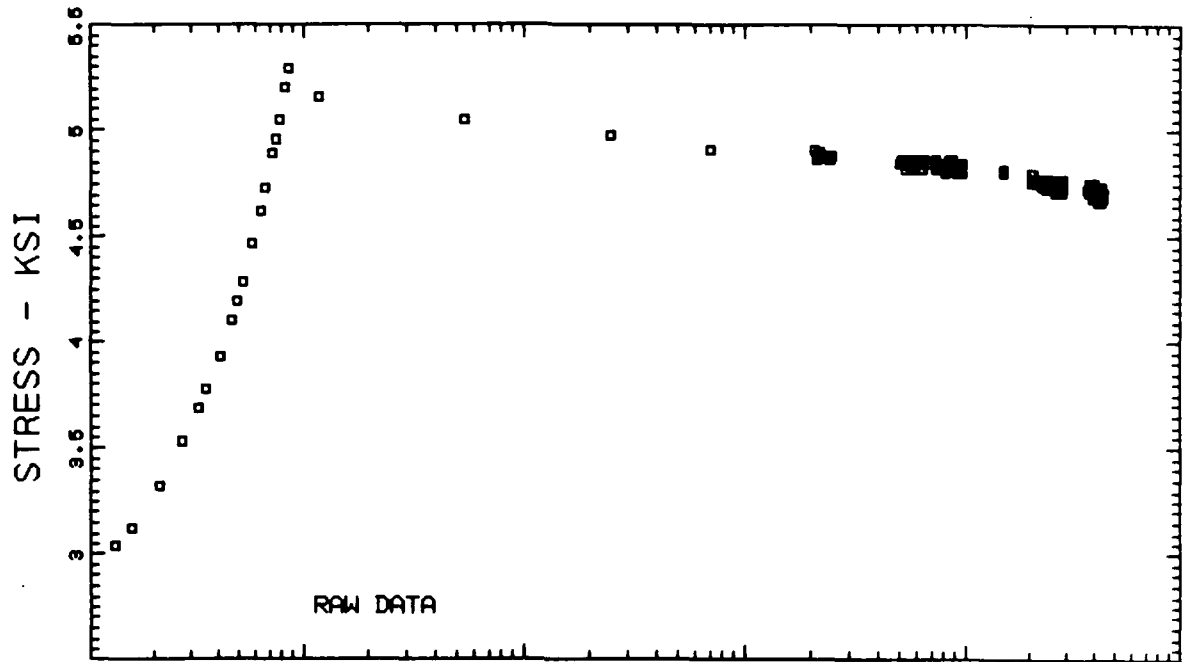

T300/5208 - STEP/RELAXATION - SPECIMEN No. 4 - STEP No. 6

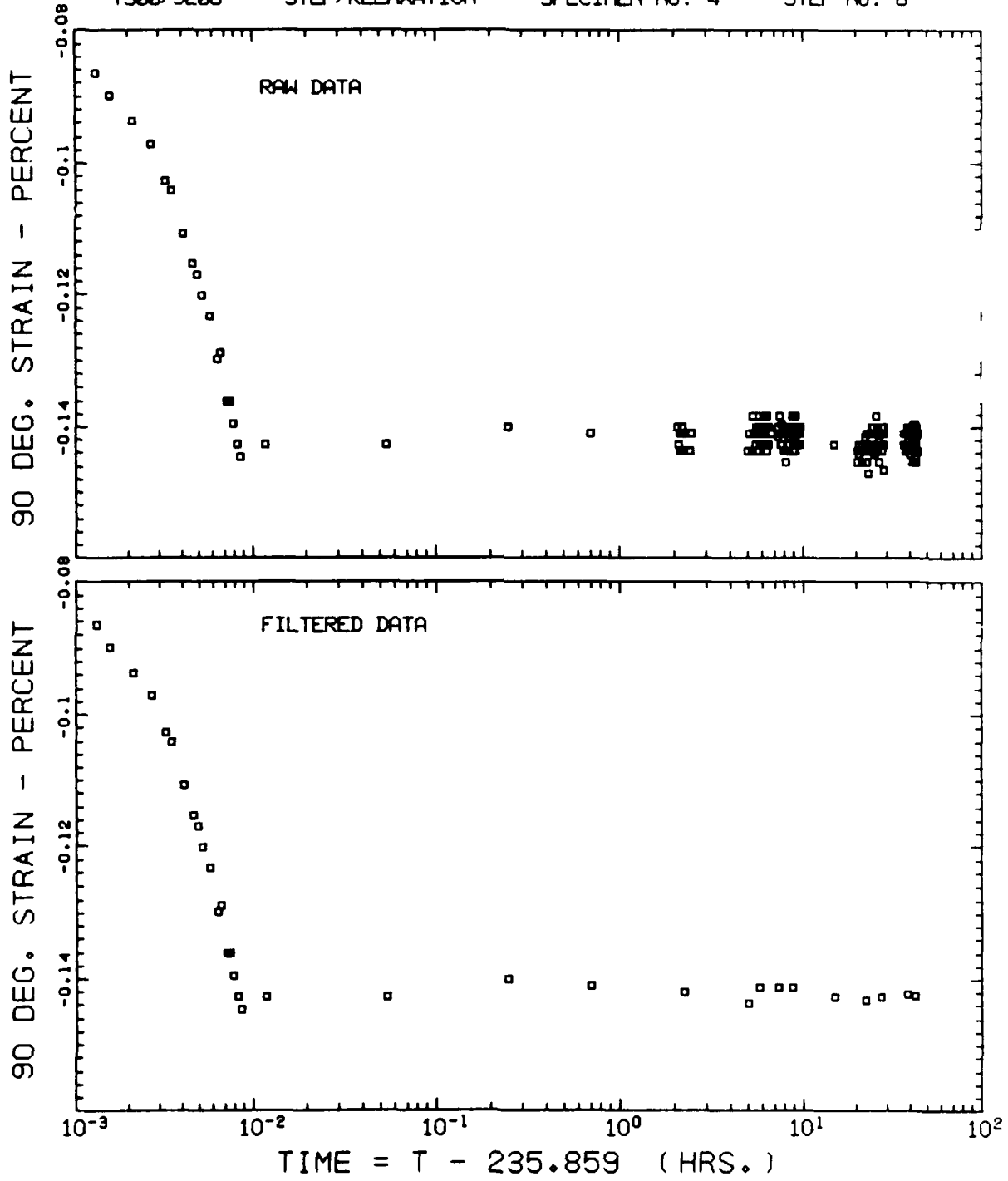



T300/S208 - STEP/RELAXATION - SPECIMEN No. 4 - STEP No. 7

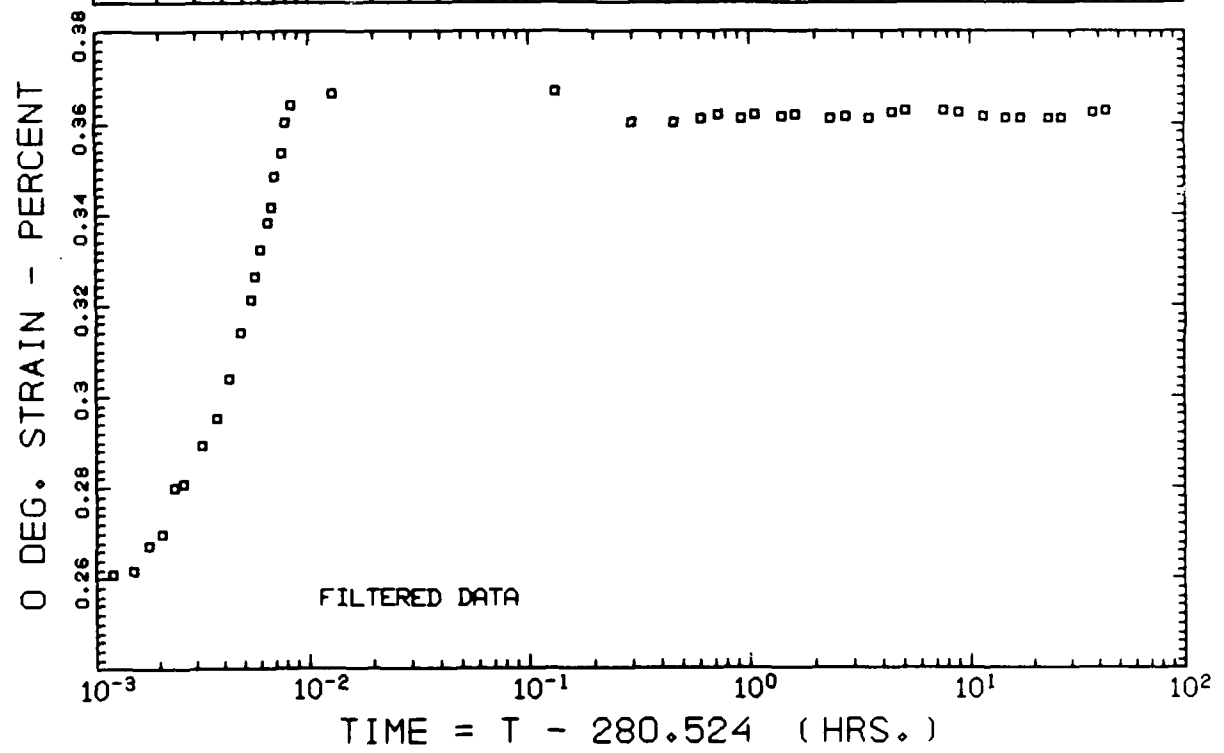
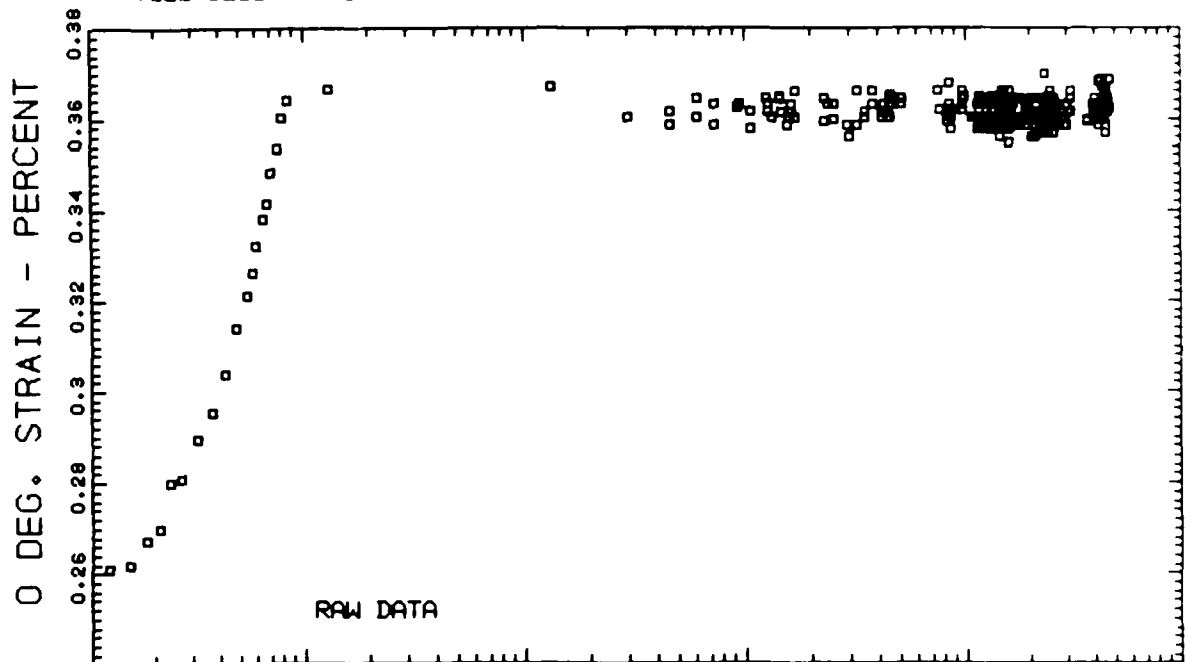

T300/5208 - STEP/RELAXATION - SPECIMEN No. 4 - STEP No. 7

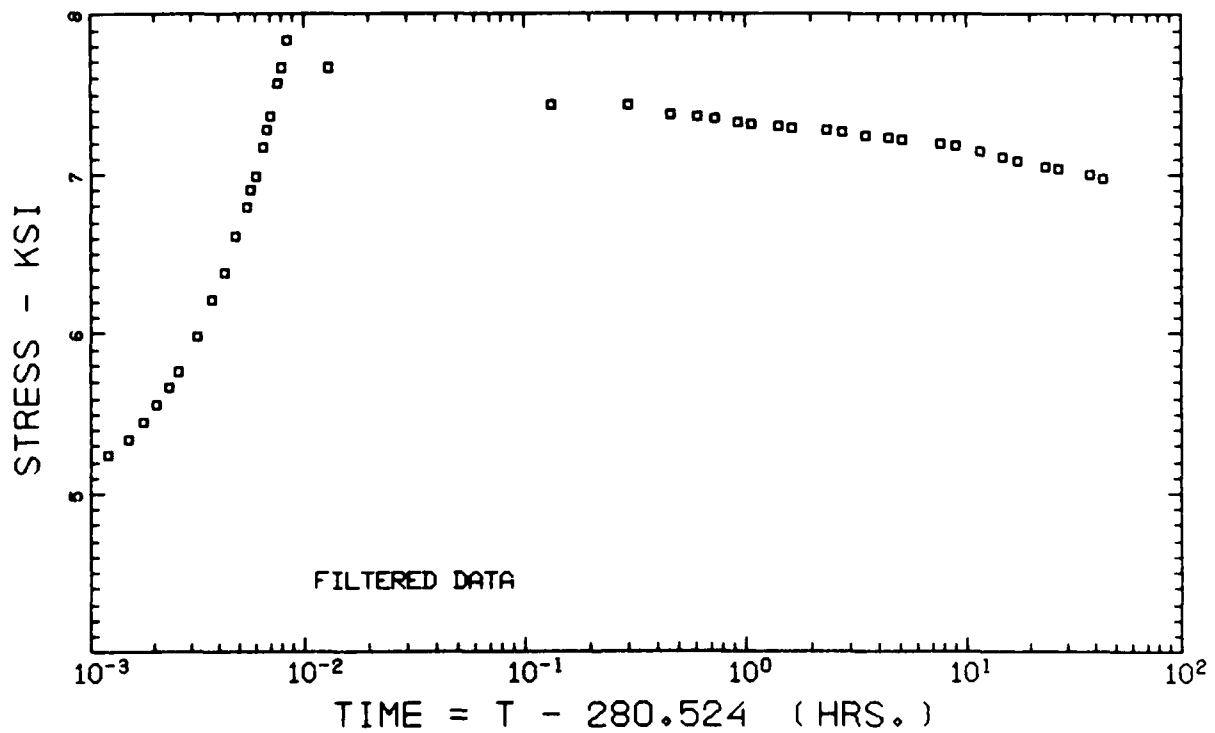
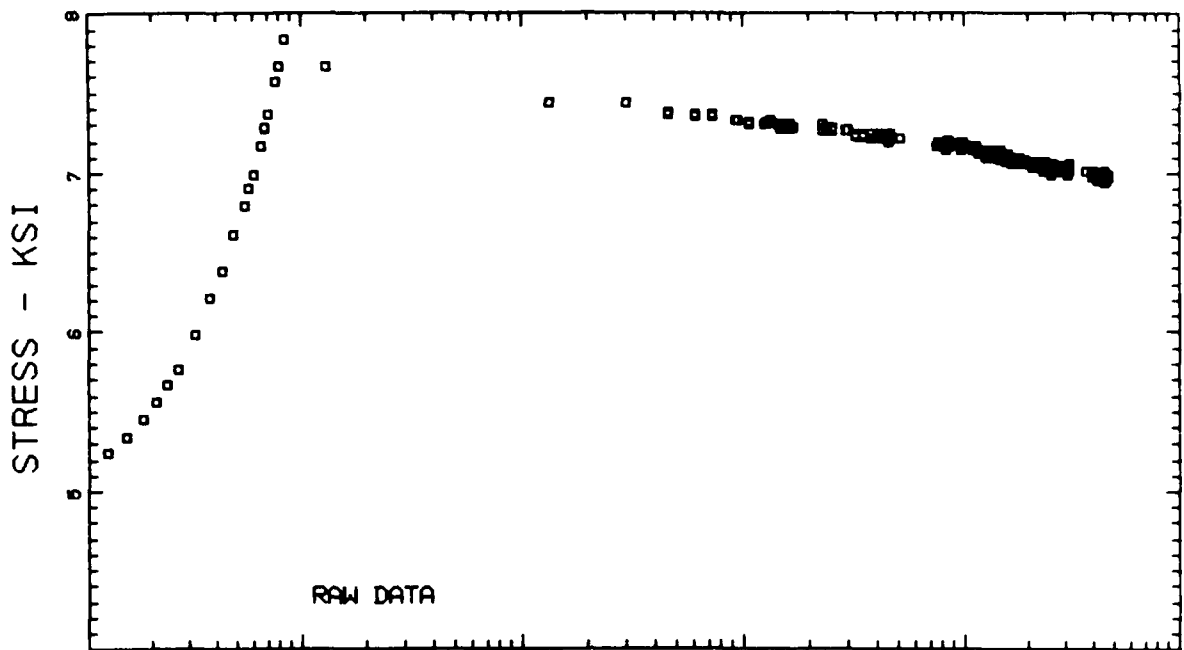

T300/5208 - STEP/RELAXATION - SPECIMEN No. 4 - STEP No. 7

90 DEG. STRAIN - PERCENT

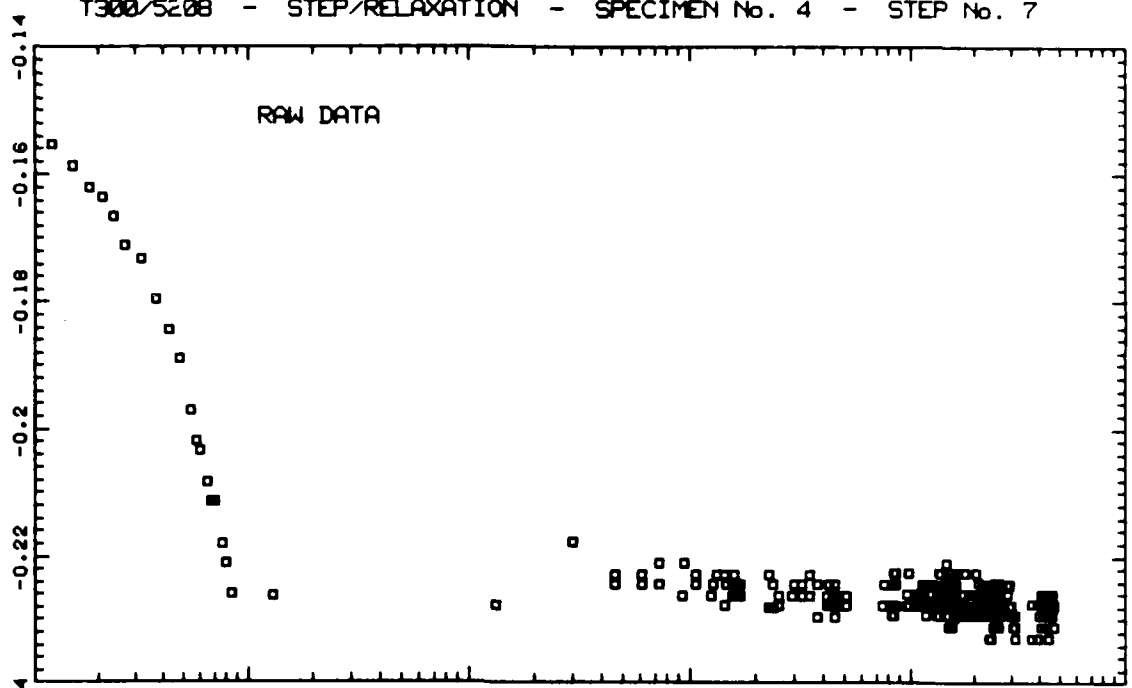

90 DEG. STRAIN - PERCENT

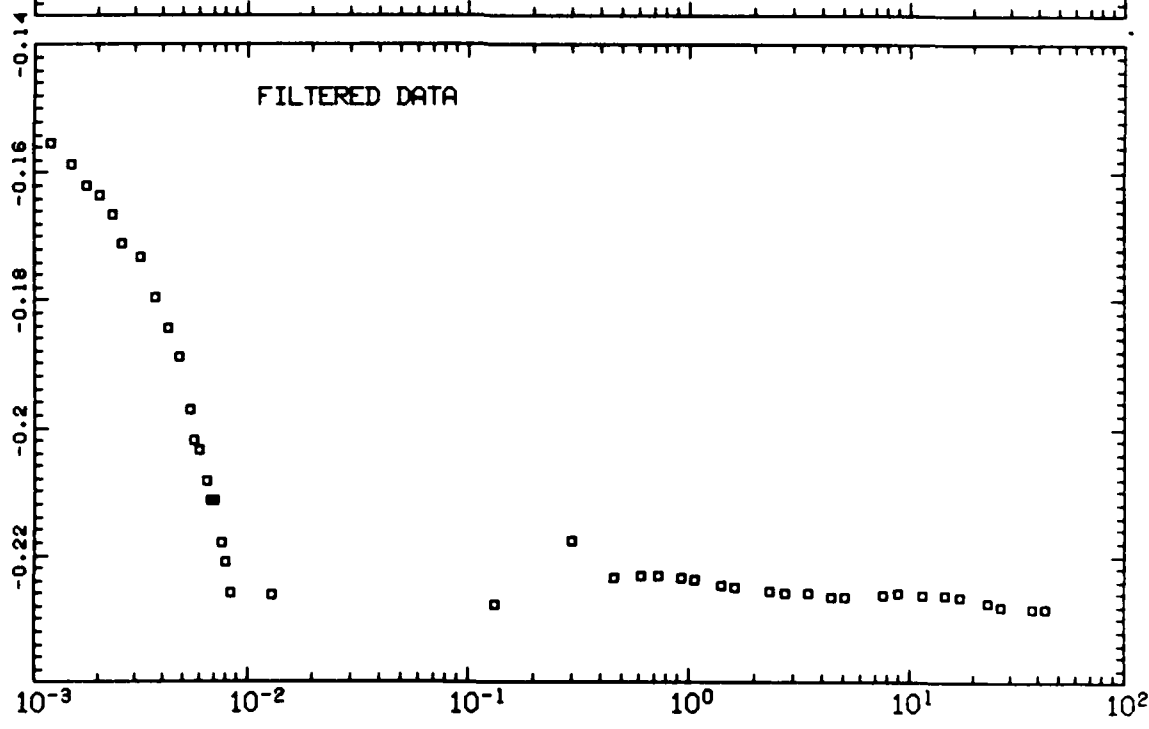

TIME = T - 280.524 (HRS.)

T300/5208 - STEP/RELAXATION - SPECIMEN No. 4 - STEP No. 8

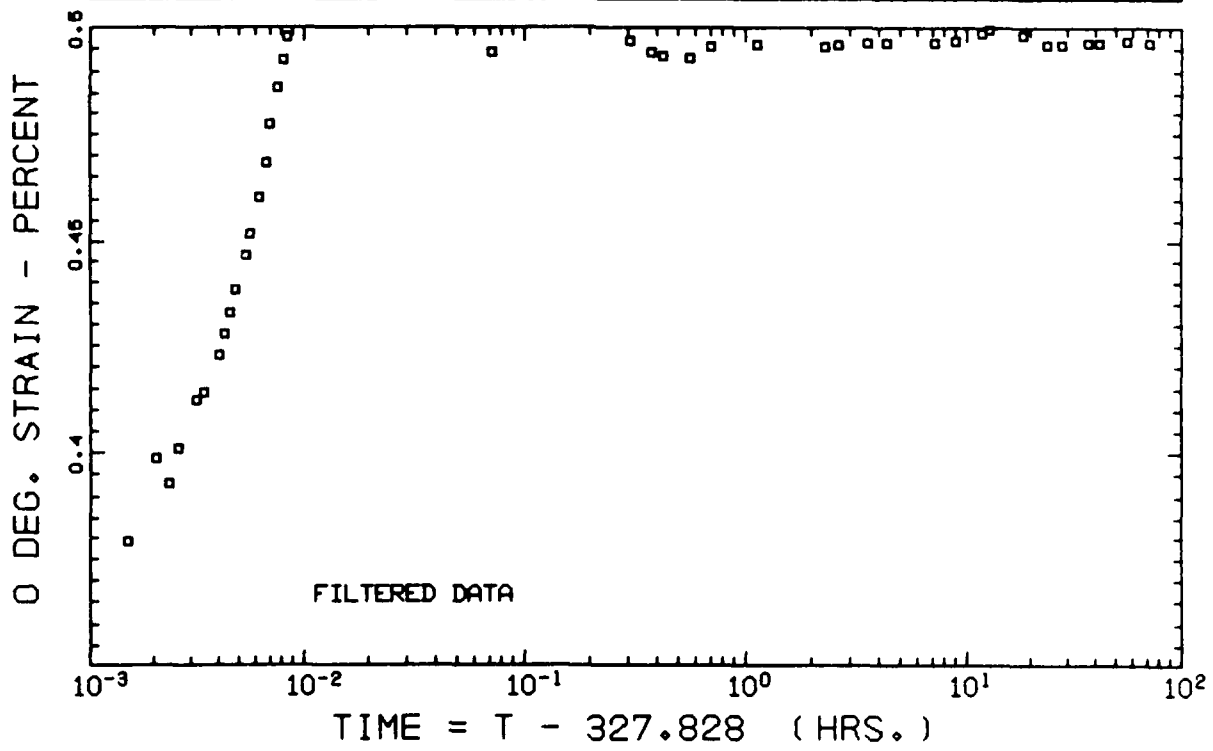
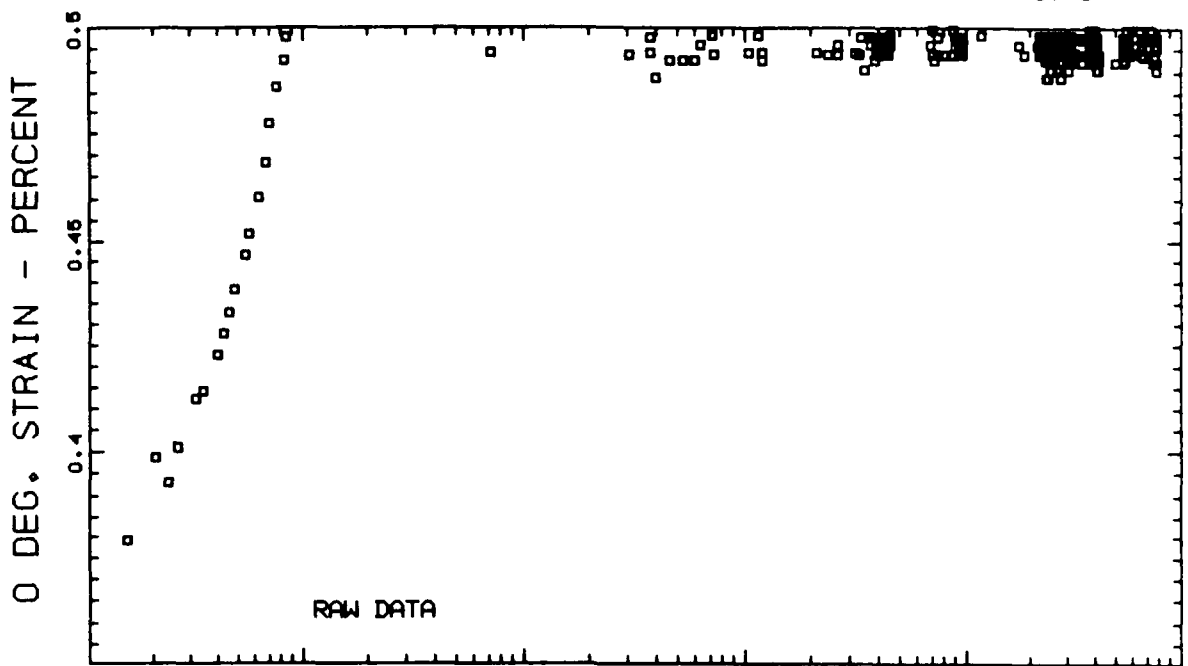

T300/S208 - STEP/RELAXATION - SPECIMEN No. 4 - STEP No. 8

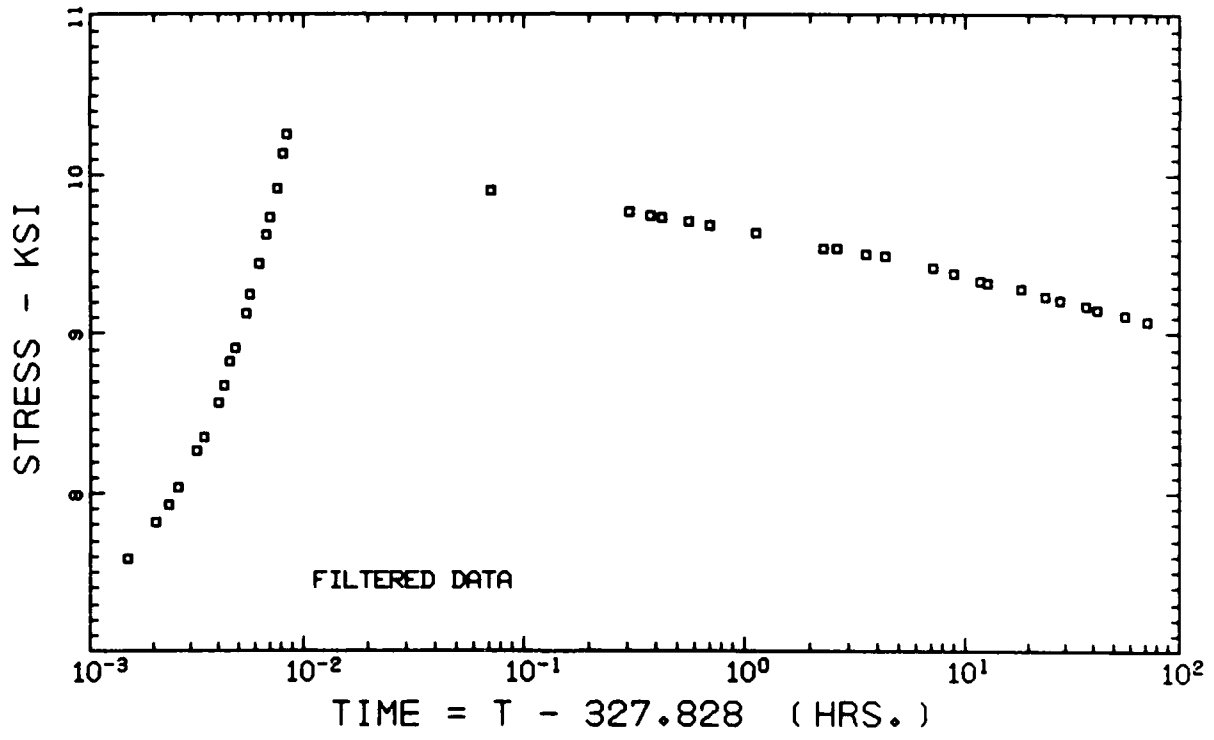
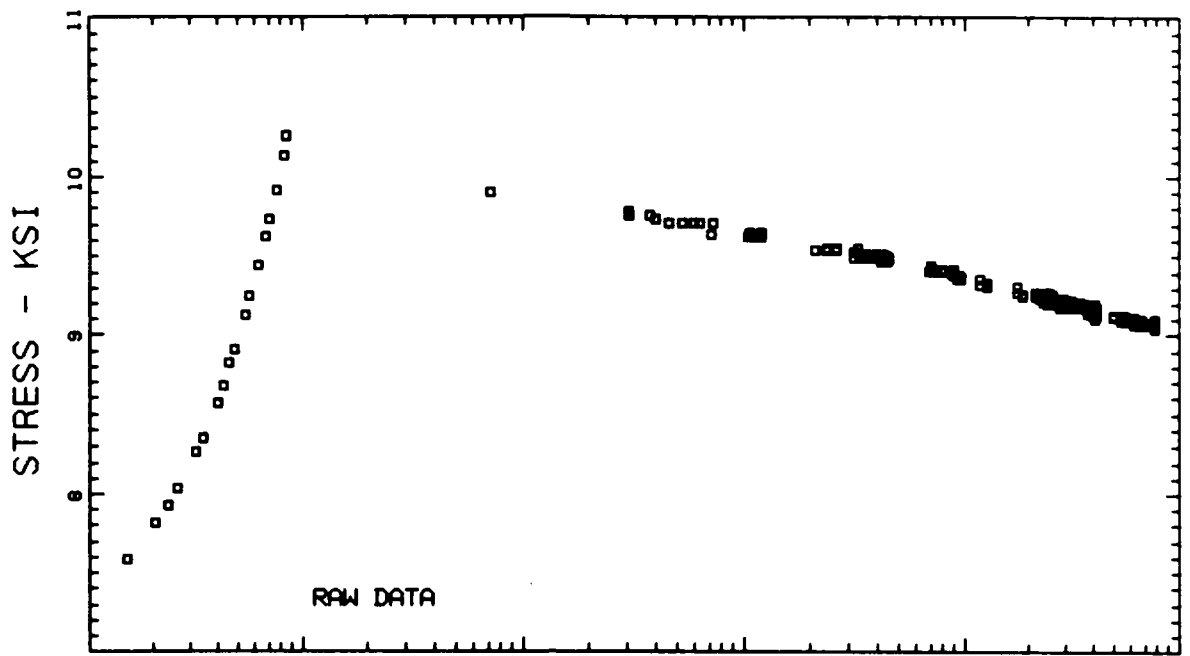

T300/5208 - STEP/RELAXATION - SPECIMEN No. 4 - STEP No. 8

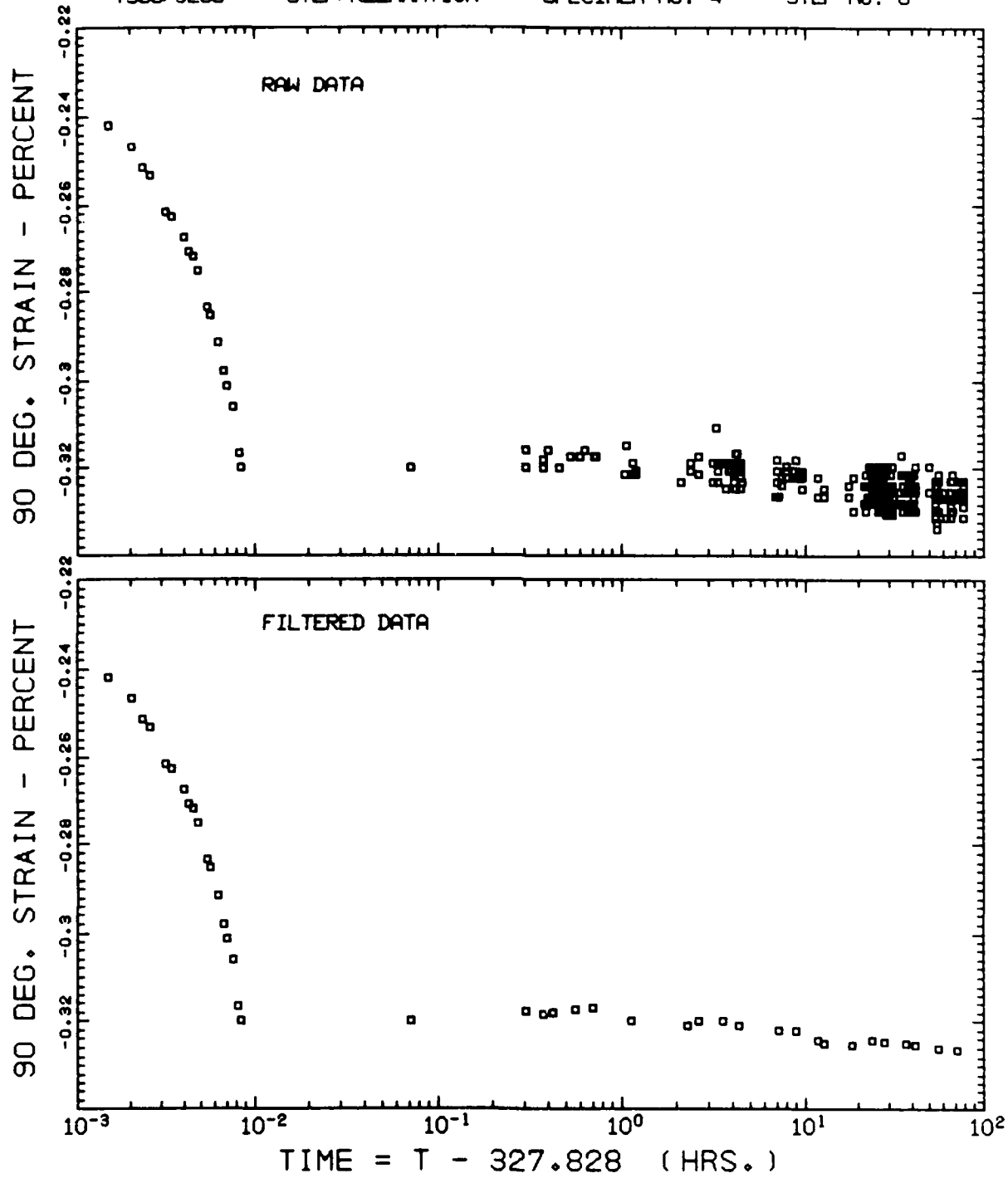

T300/5208 - STEP/RELAXATION - SPECIMEN No. 4 - STEP No. 9

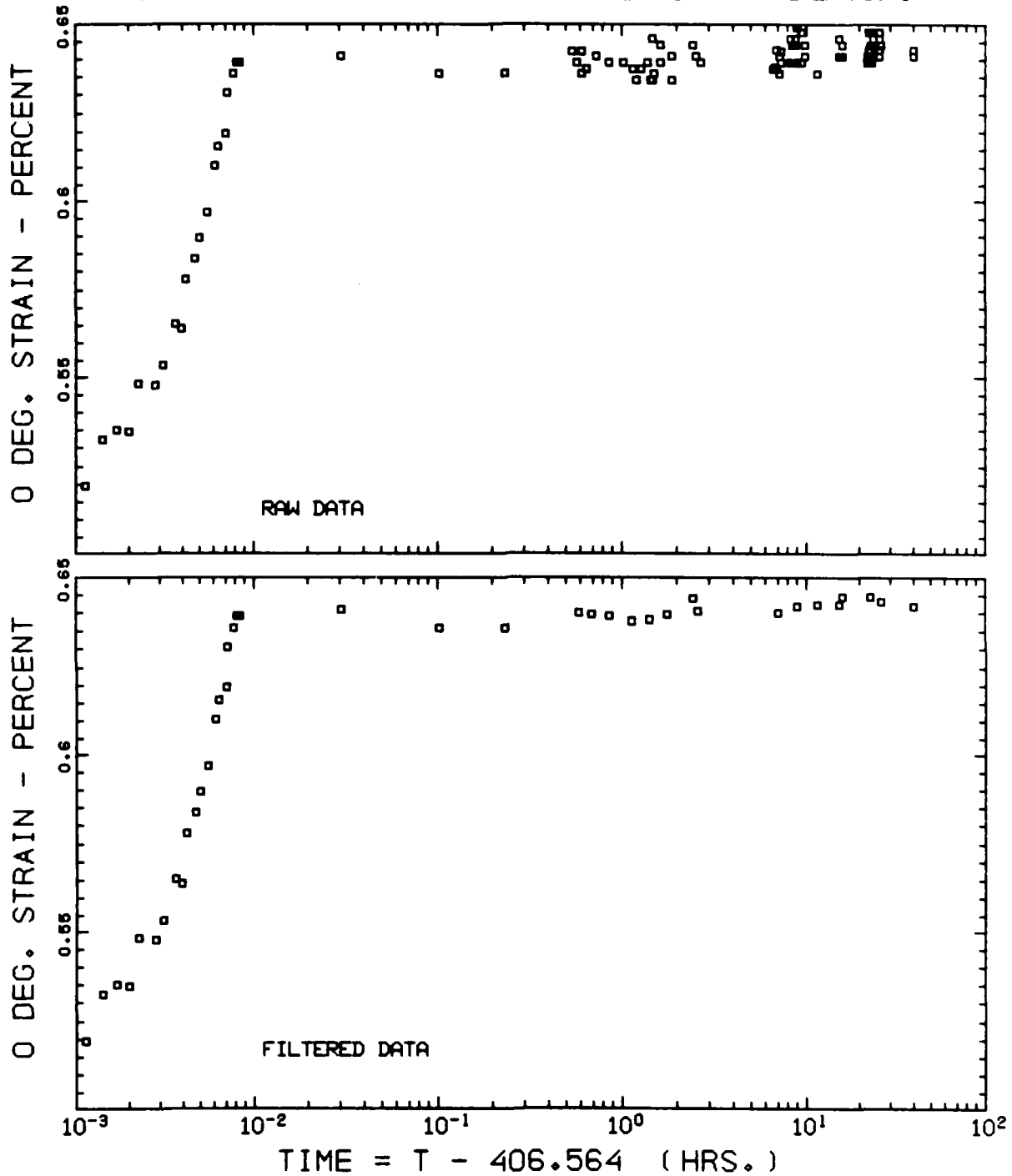

T300/5208 - STEP/RELAXATION - SPECIMEN No. 4 - STEP No. 9

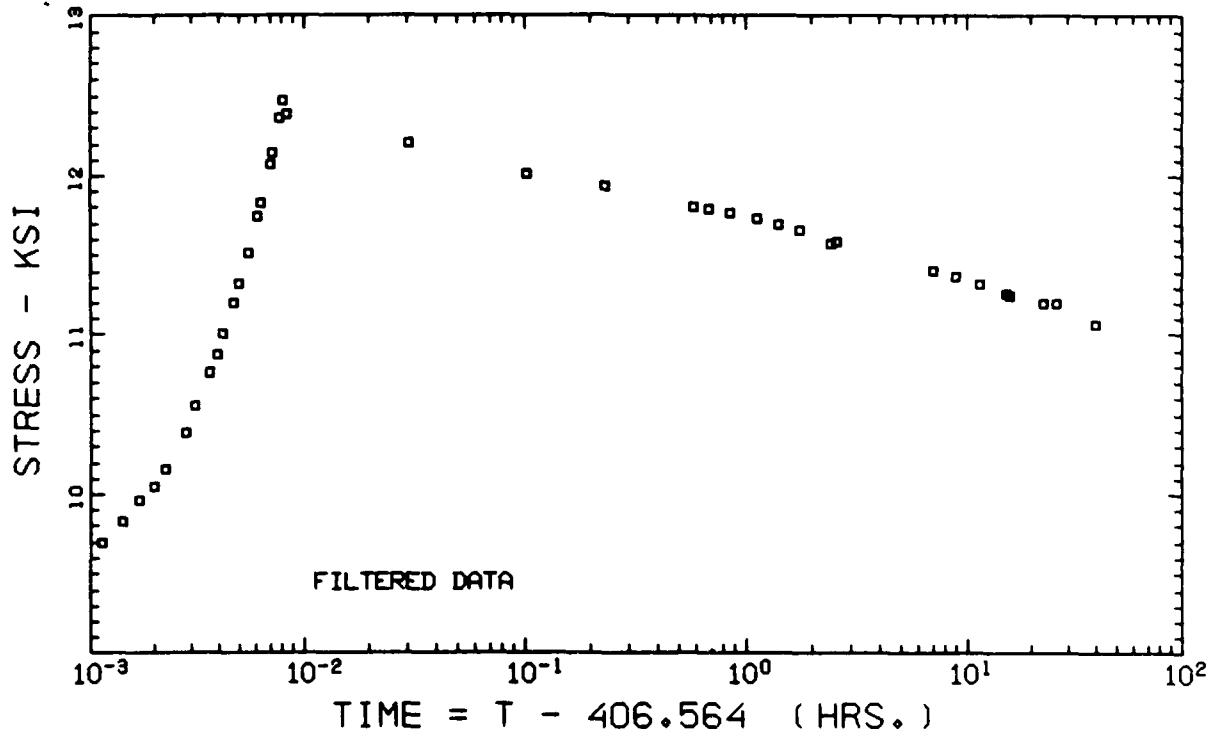
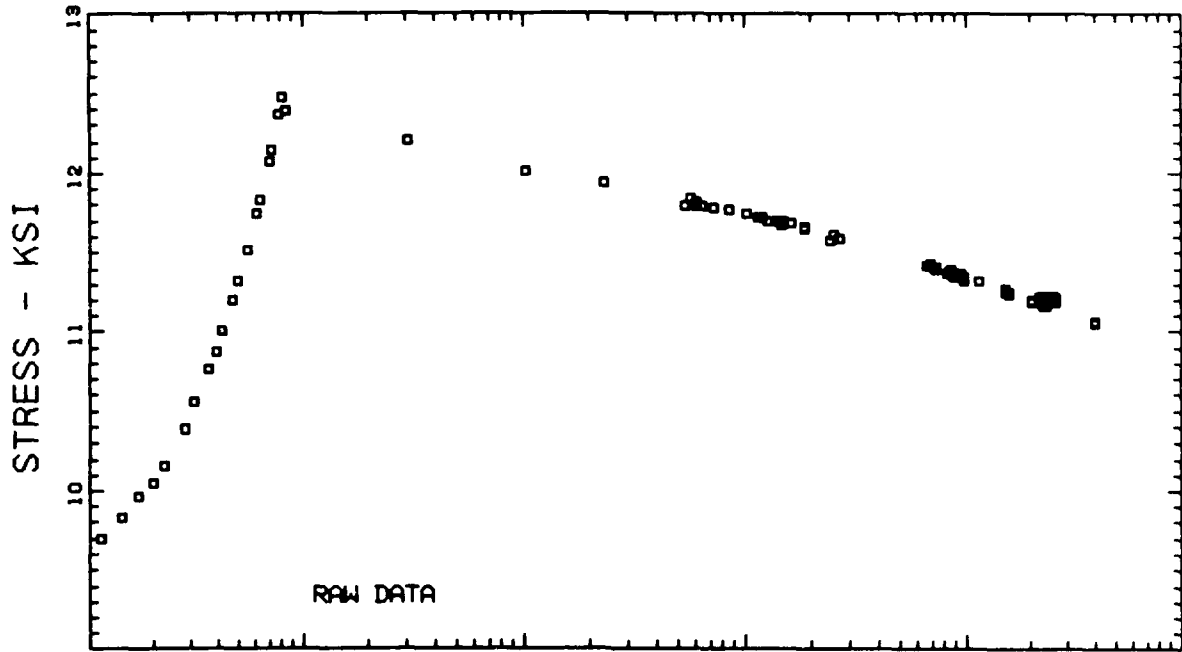



T300/5208 - STEP/RELAXATION - SPECIMEN No. 4 - STEP No. 9

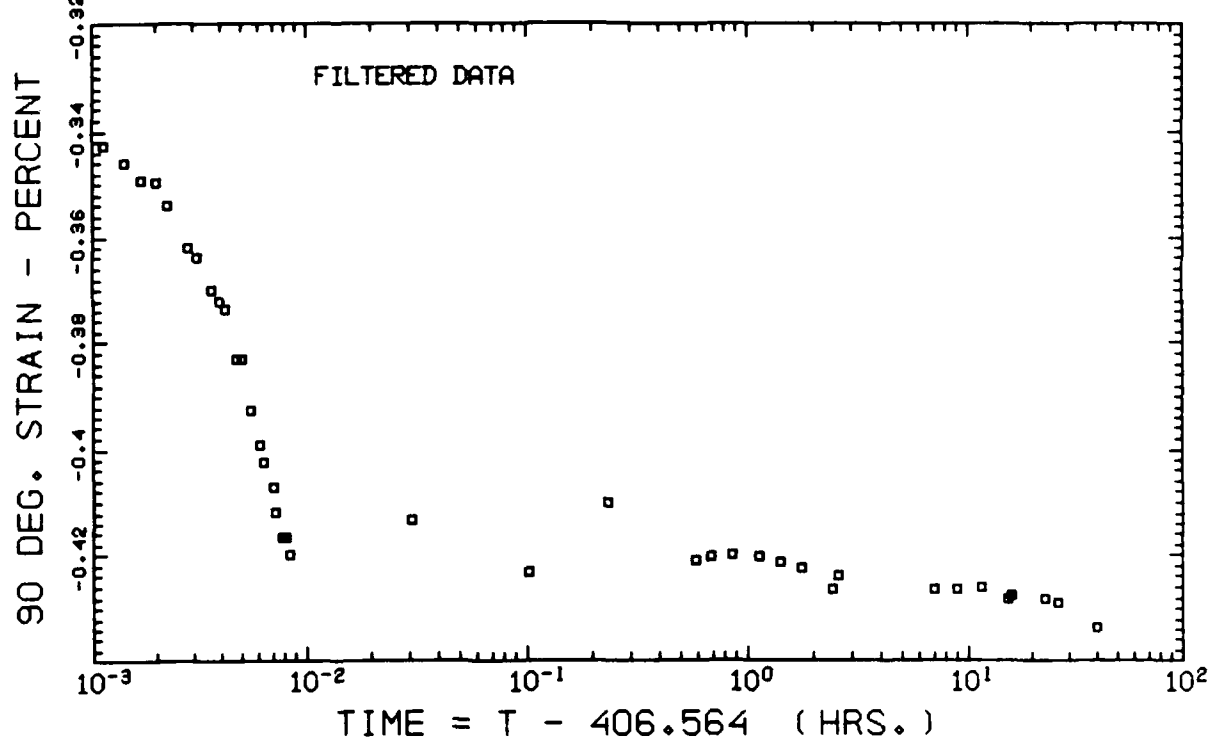
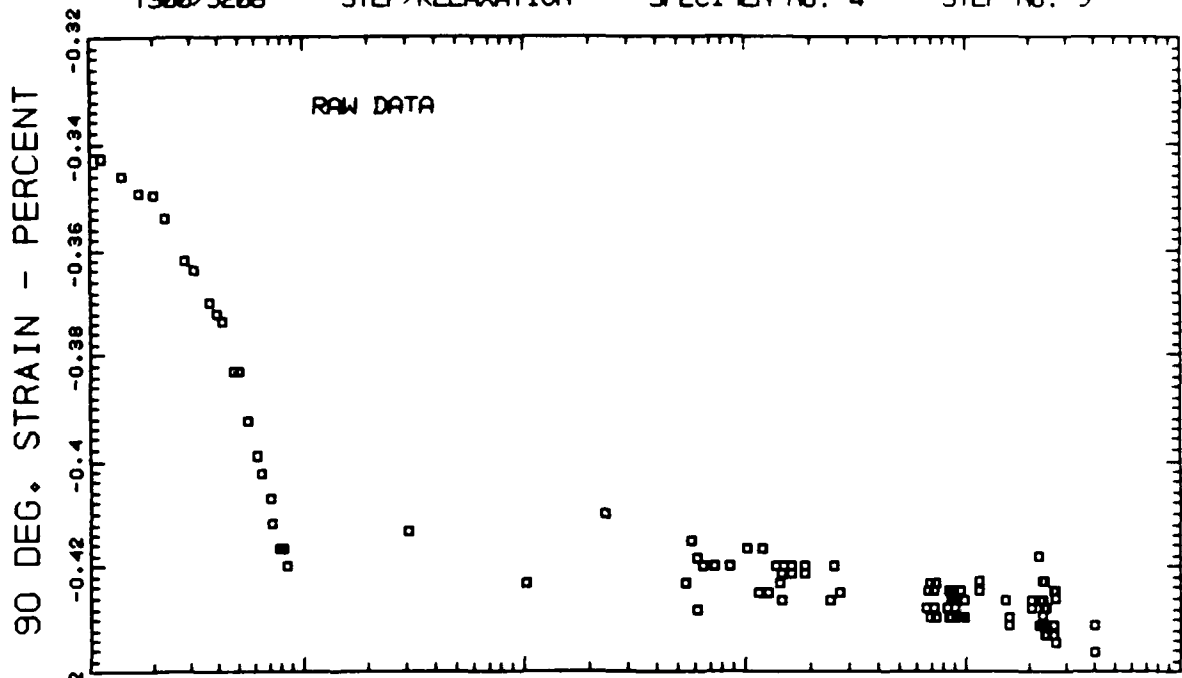

T300/5208 - STEP/RELAXATION - SPECIMEN NO. 5

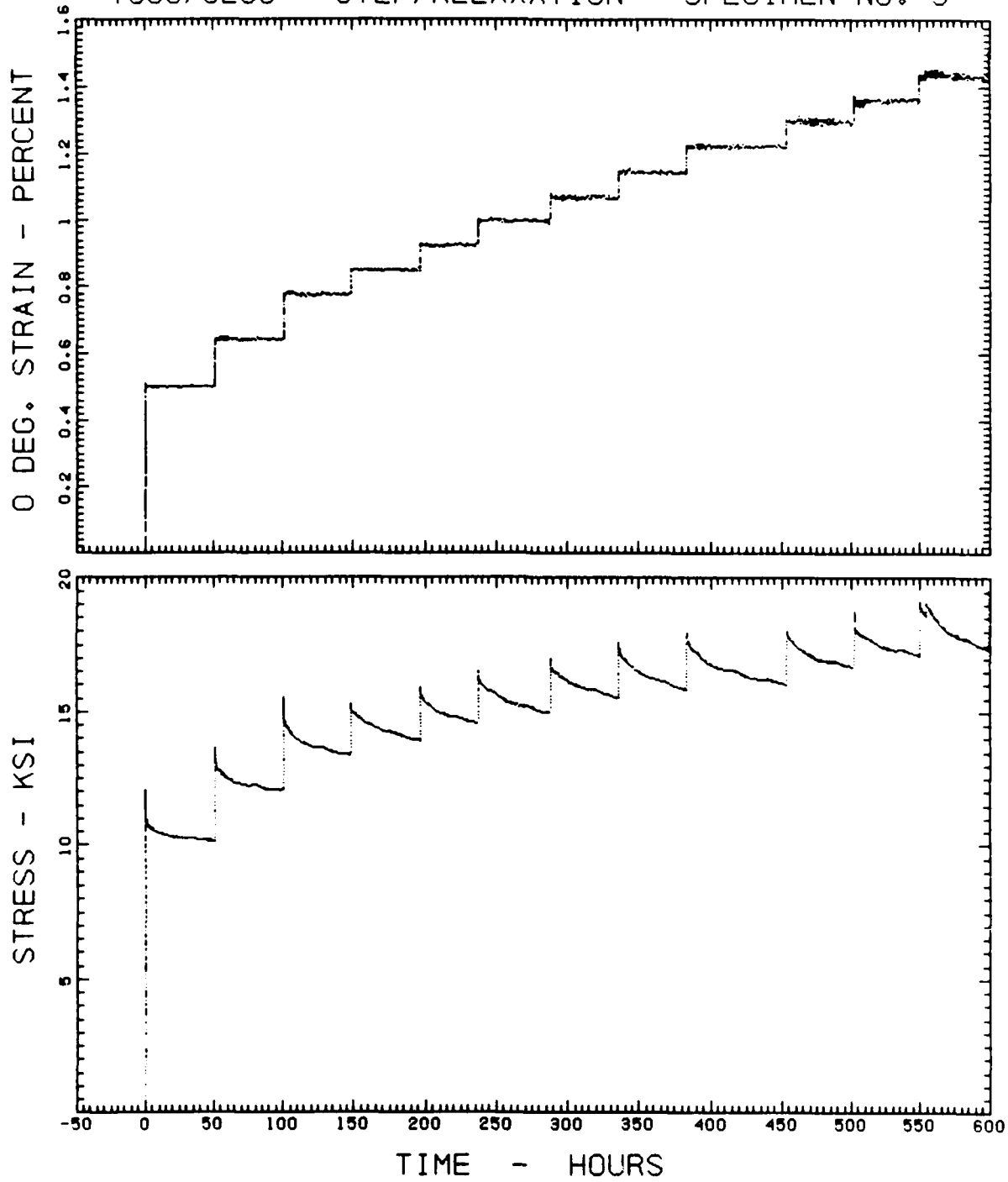

T300/5208 - STEP/RELAXATION - SPECIMEN NO. 5

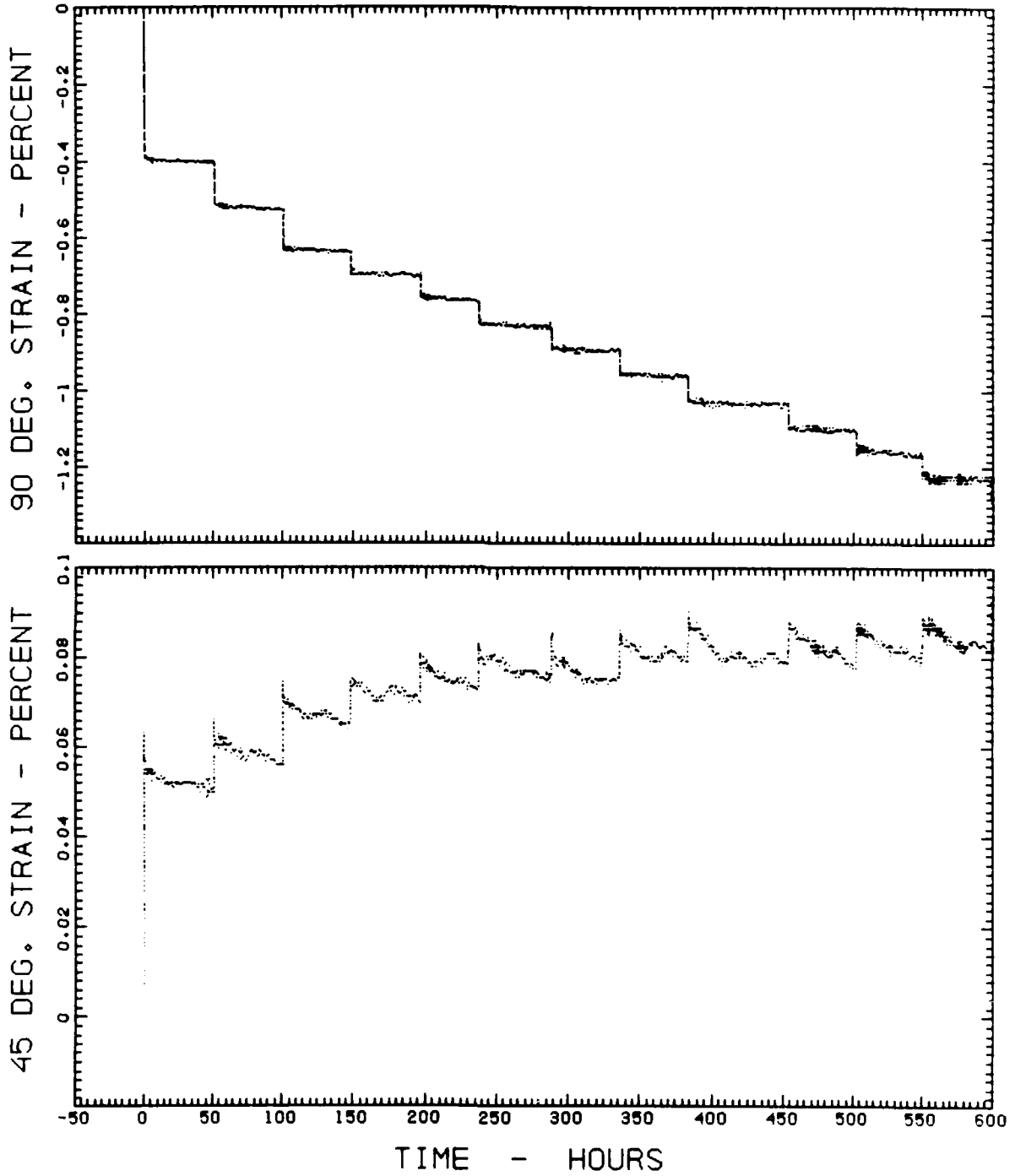

T300/5208 - STEP/RELAXATION - SPECIMEN No. 5 - STEP No. 1

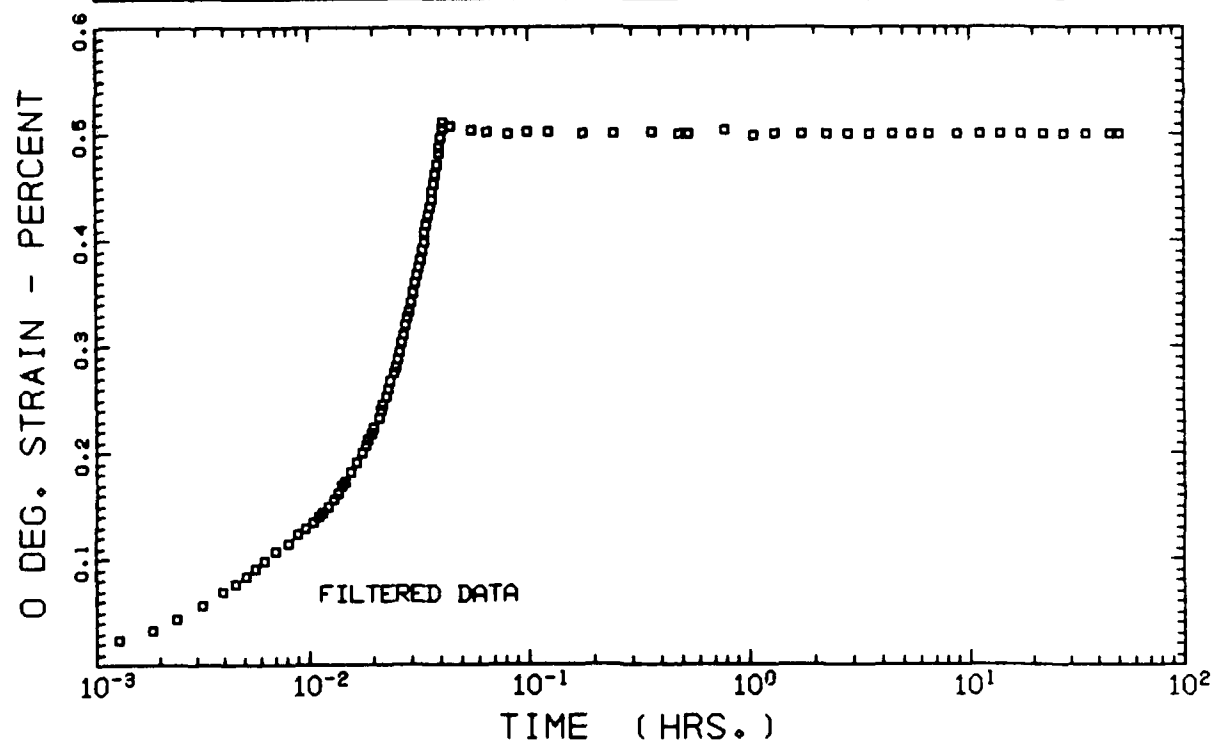
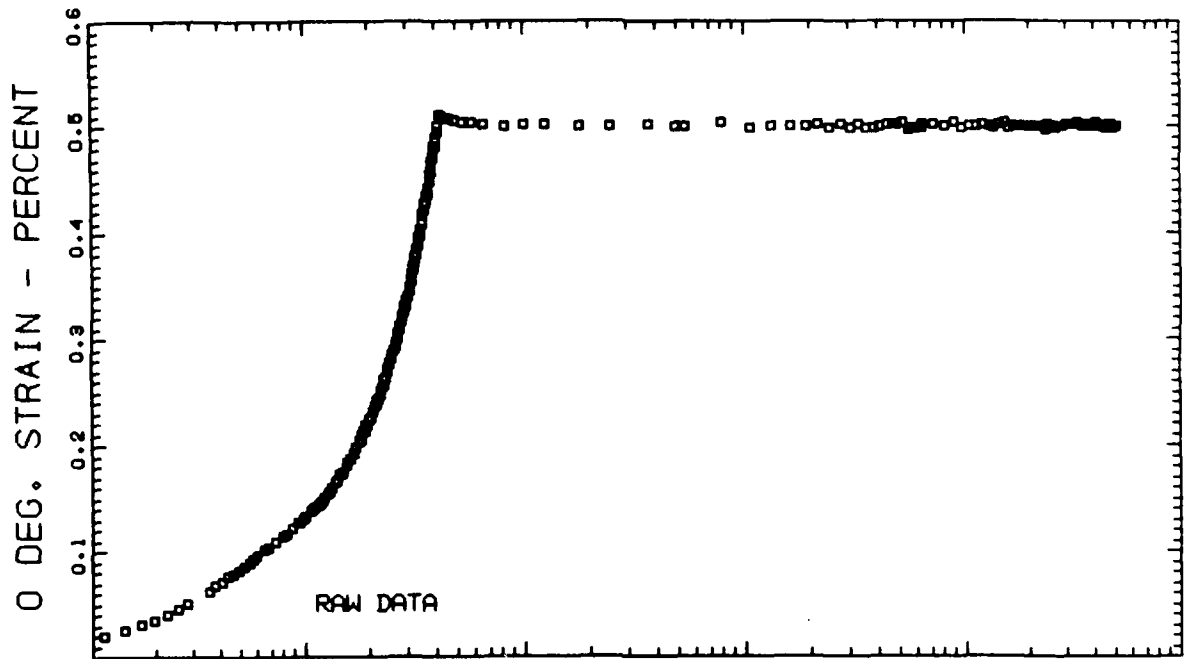

T300/52E8 - STEP/RELAXATION - SPECIMEN No. 5 - STEP No. 1

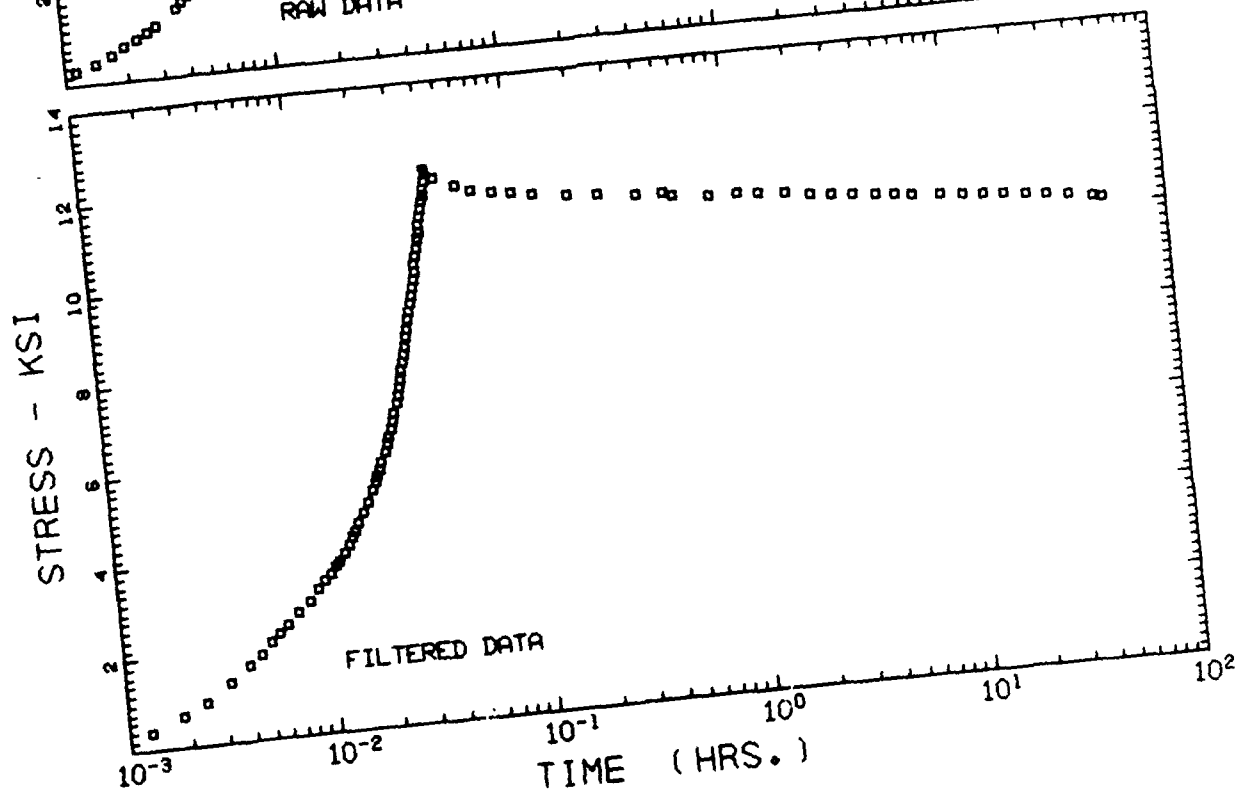
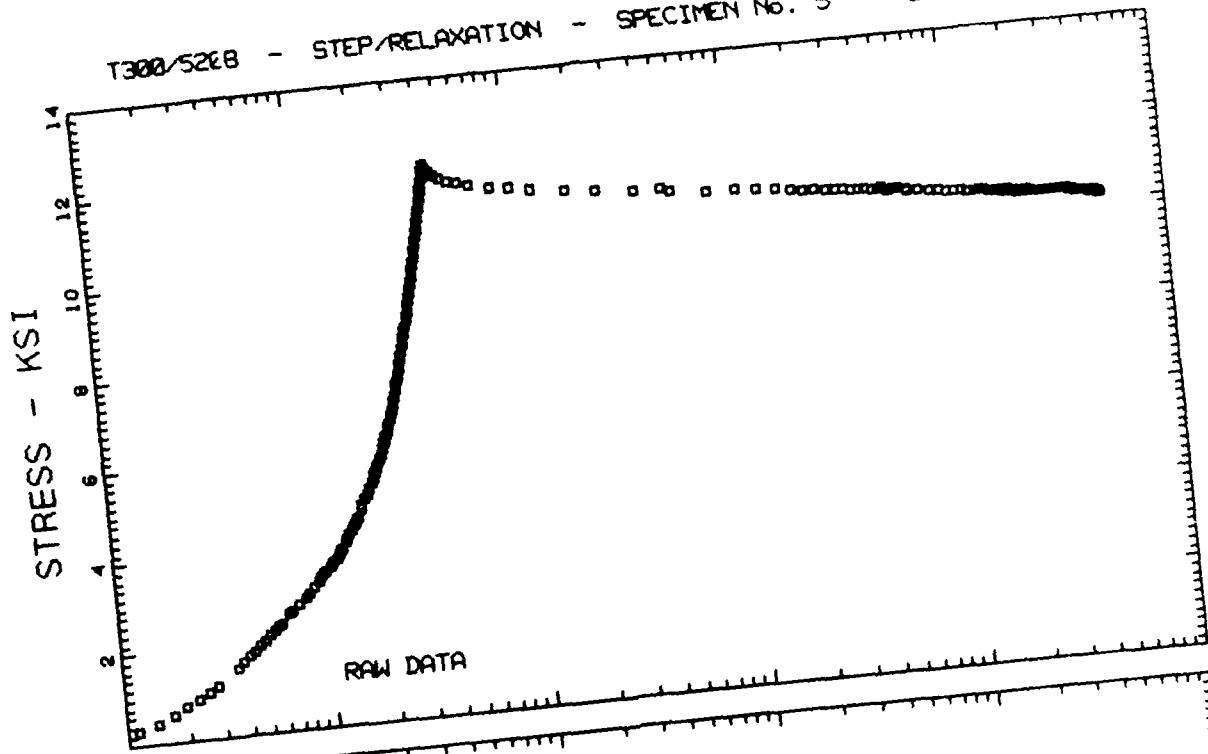

T300/5208 - STEP/RELAXATION - SPECIMEN No. 5 - STEP No. 1

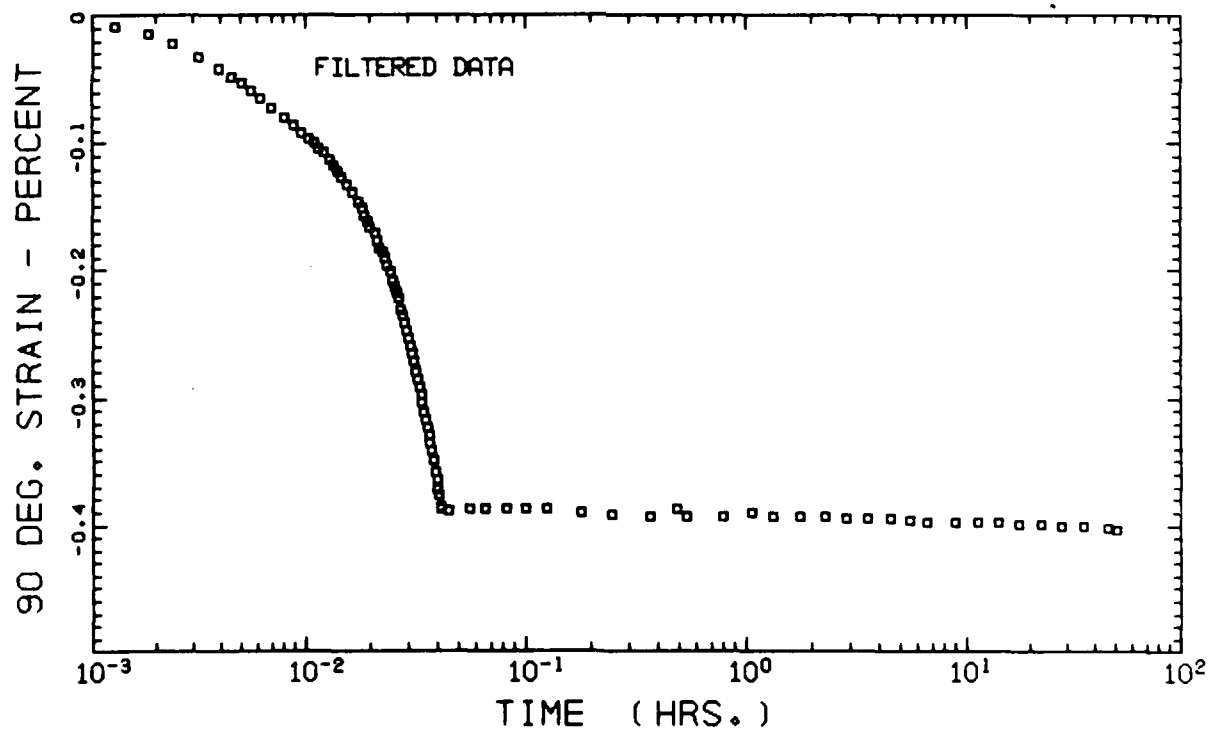
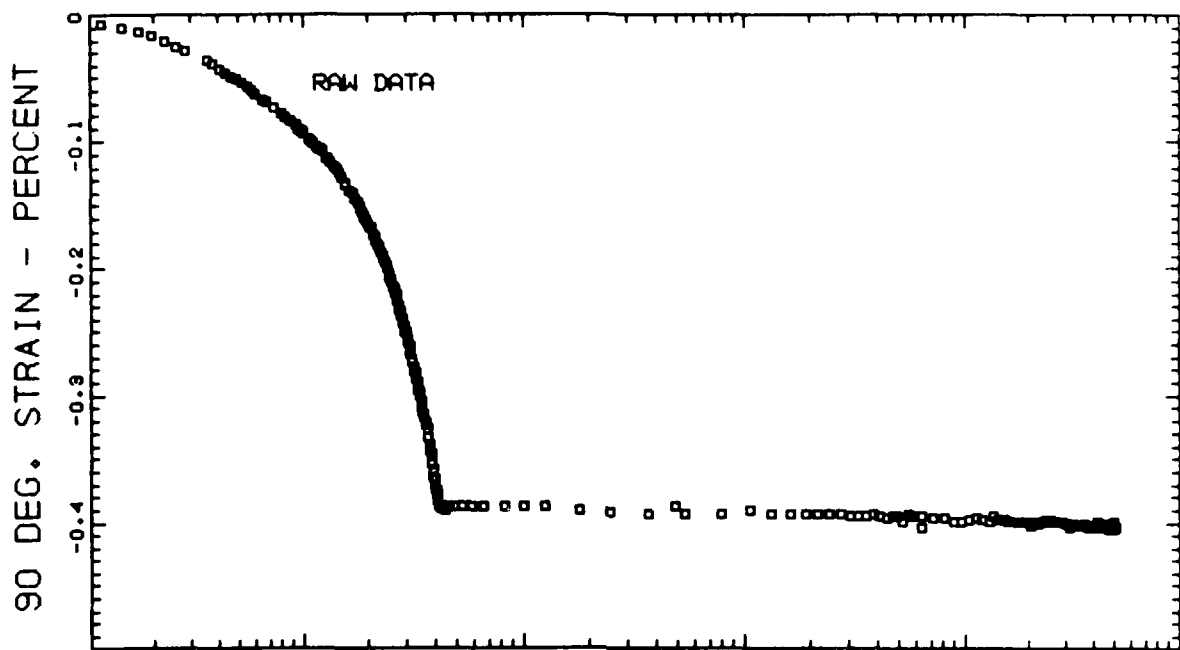

T300/5208 - STEP/RELAXATION - SPECIMEN No. 5 - STEP No. 1

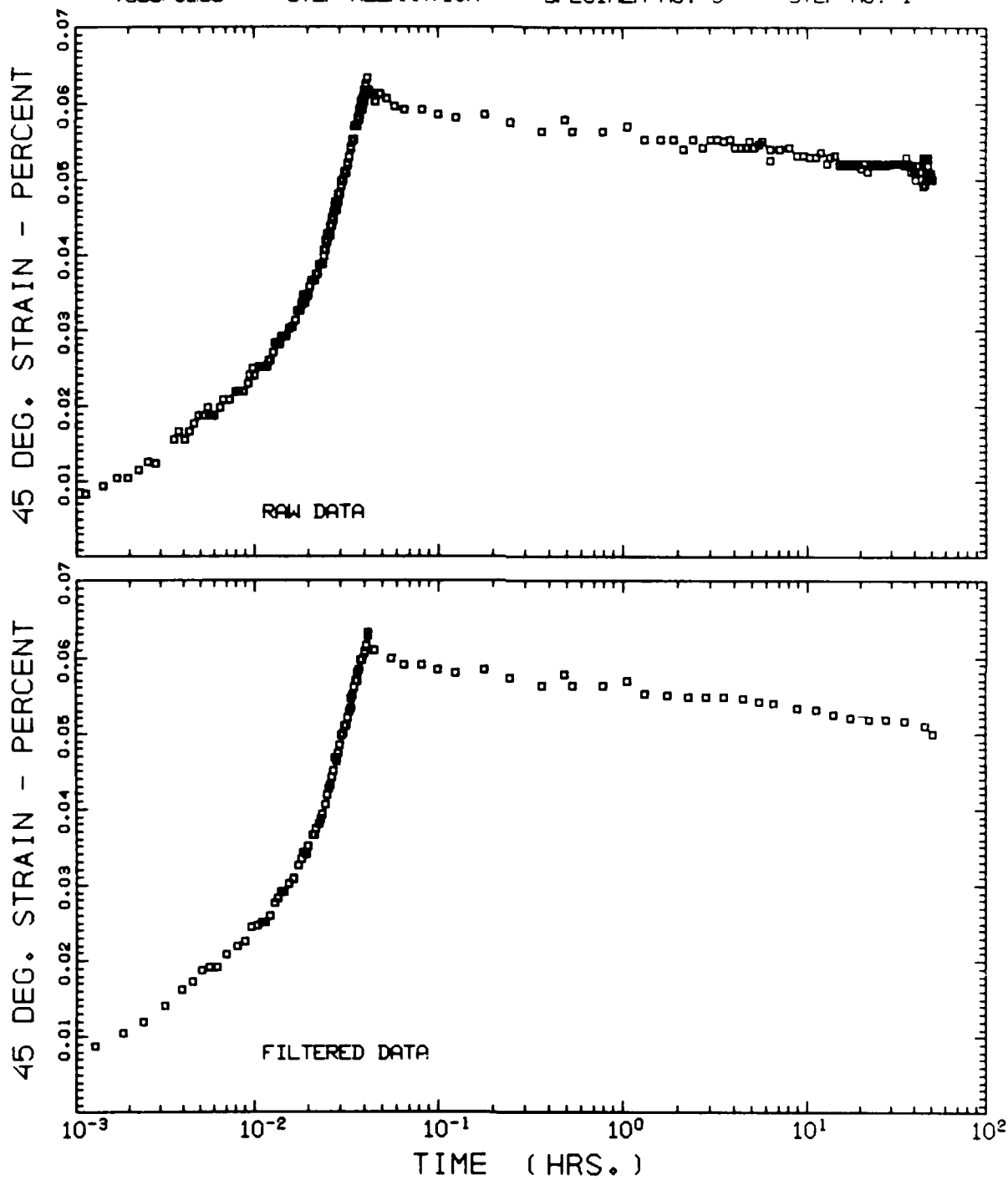

T300/S208 - STEP/RELAXATION - SPECIMEN No. 5 - STEP No. 2

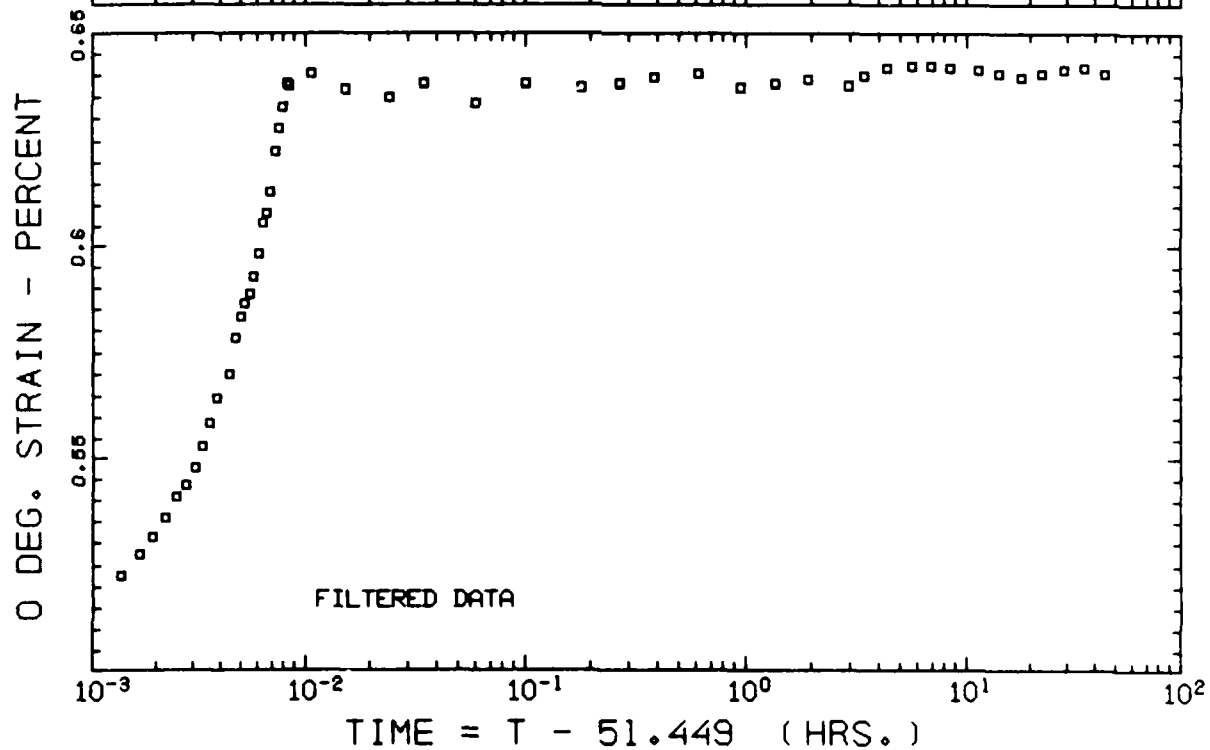
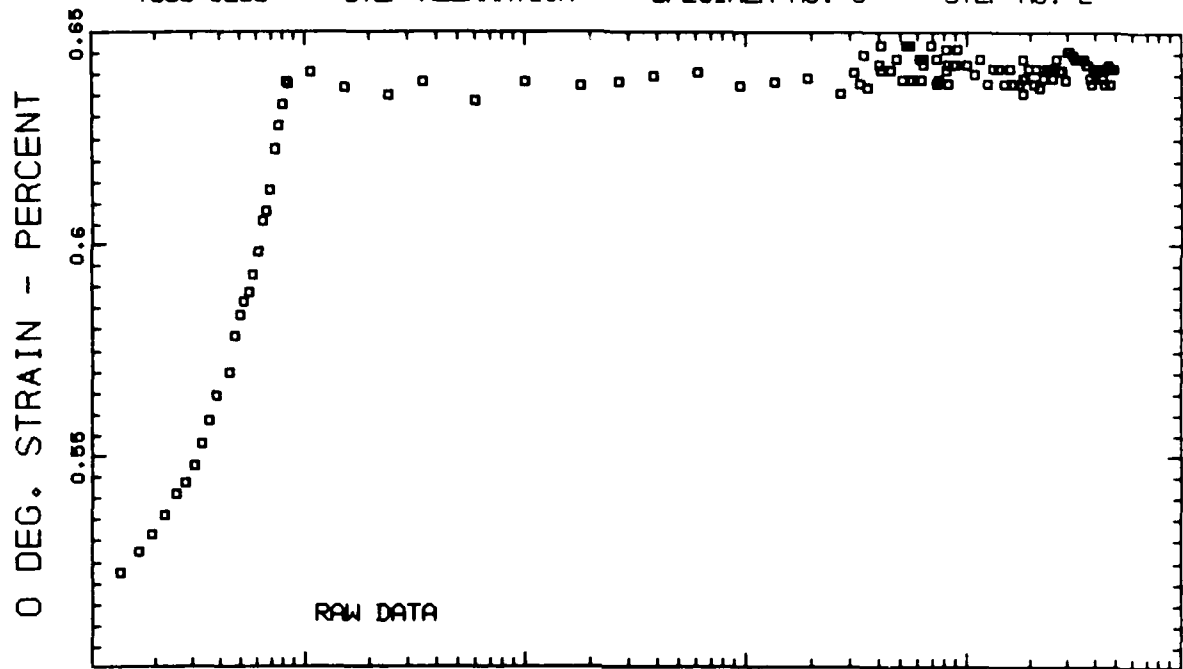



T300/S208 - STEP/RELAXATION - SPECIMEN No. 5 - STEP No. 2

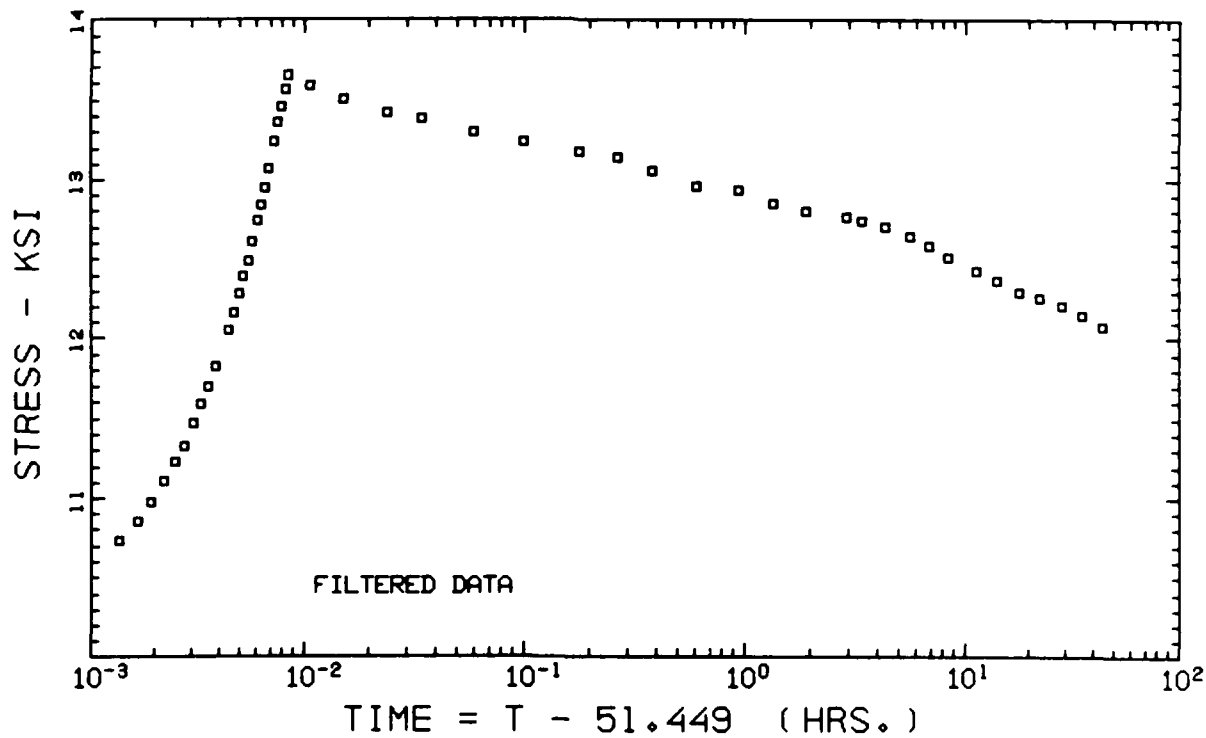
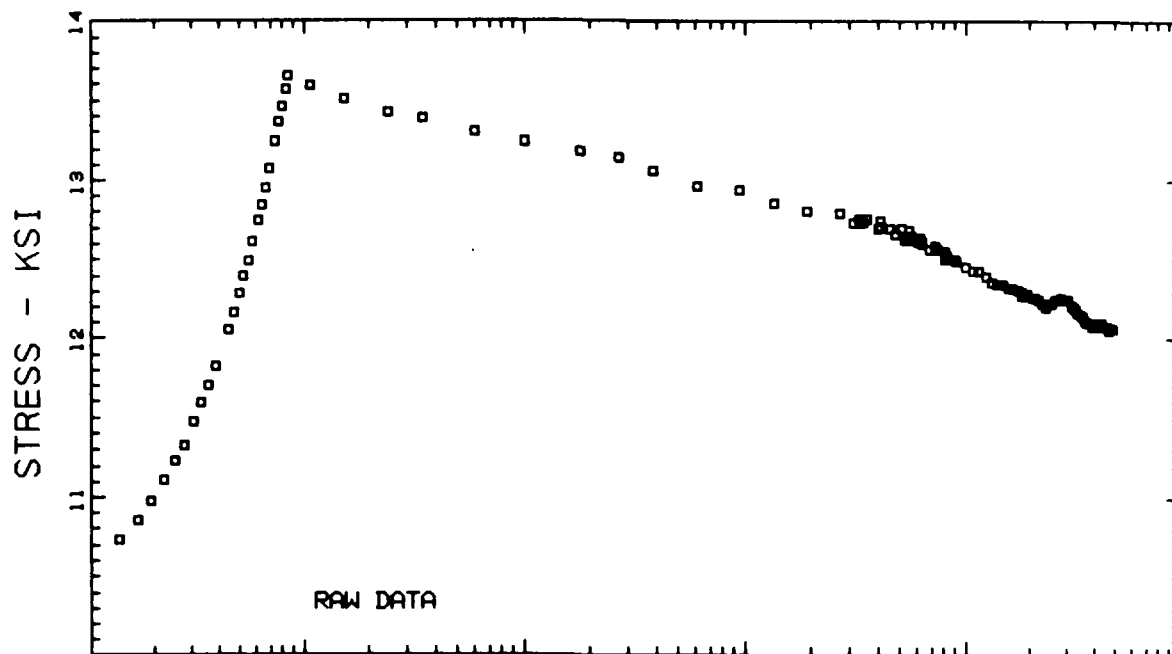

TIME = T - 51.449 (HRS.)

T300/5208 - STEP/RELAXATION - SPECIMEN No. 5 - STEP No. 2

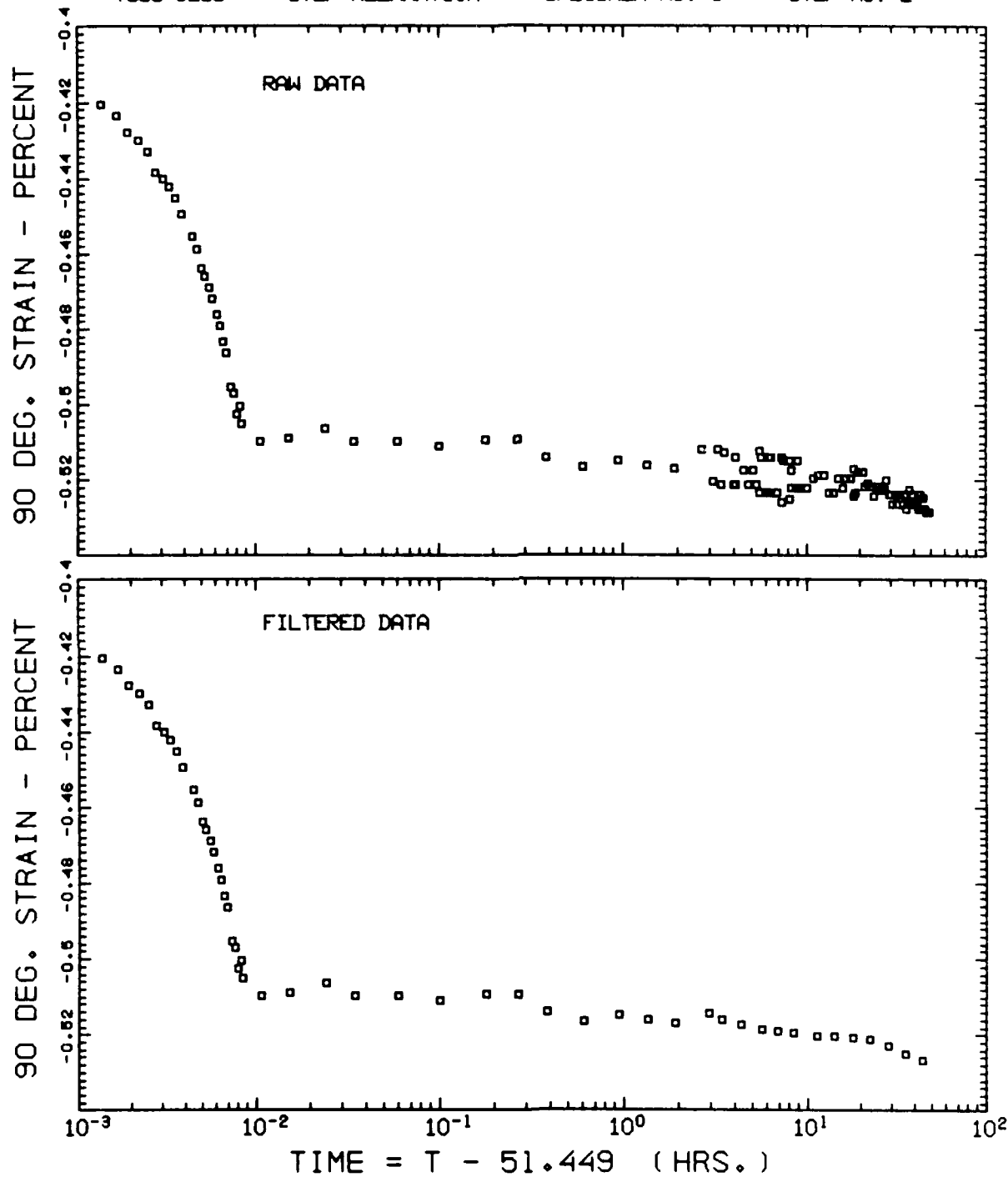

T300/S208 - STEP/RELAXATION - SPECIMEN No. 5 - STEP No. 2

45 DEG. STRAIN - PERCENT

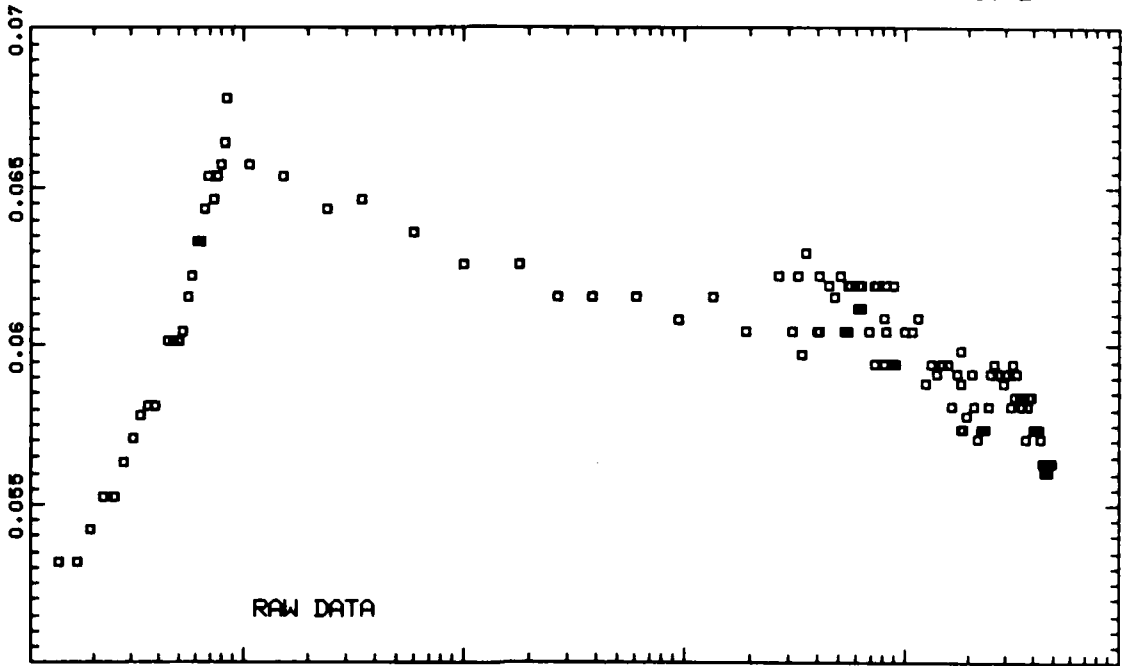

45 DEG. STRAIN - PERCENT

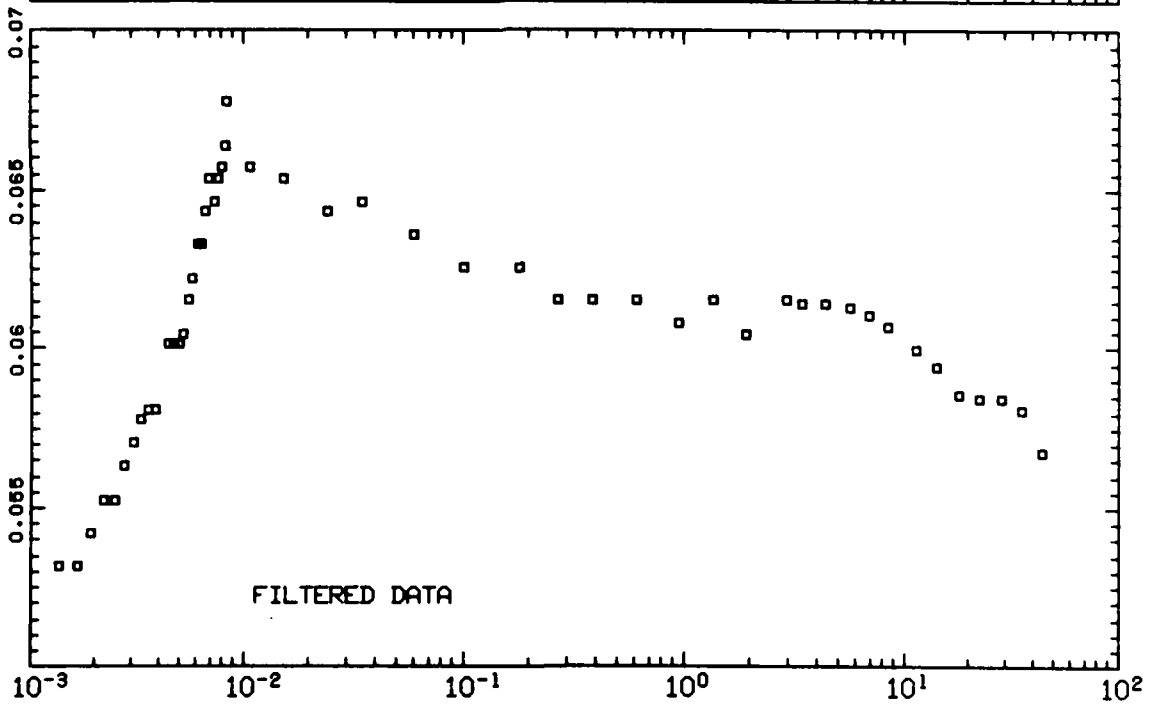

TIME = T - 51.449 (HRS.)

T300/5208 - STEP/RELAXATION - SPECIMEN No. 5 - STEP No. 3

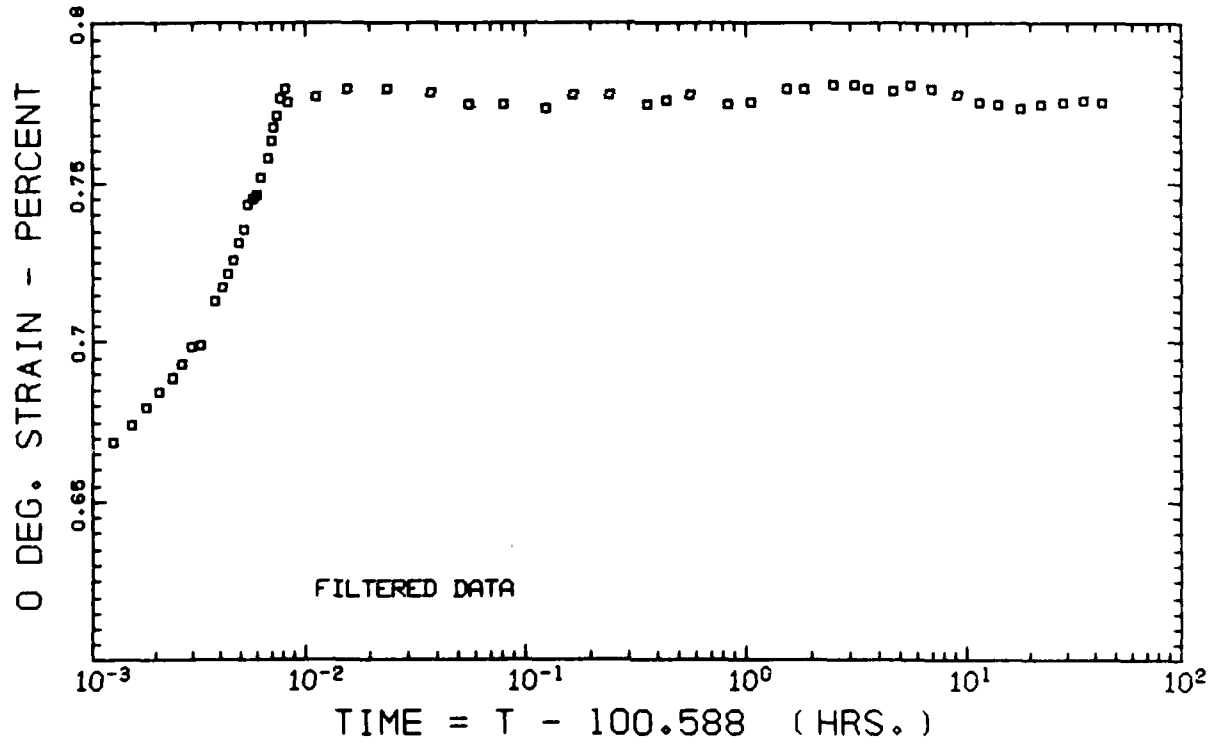
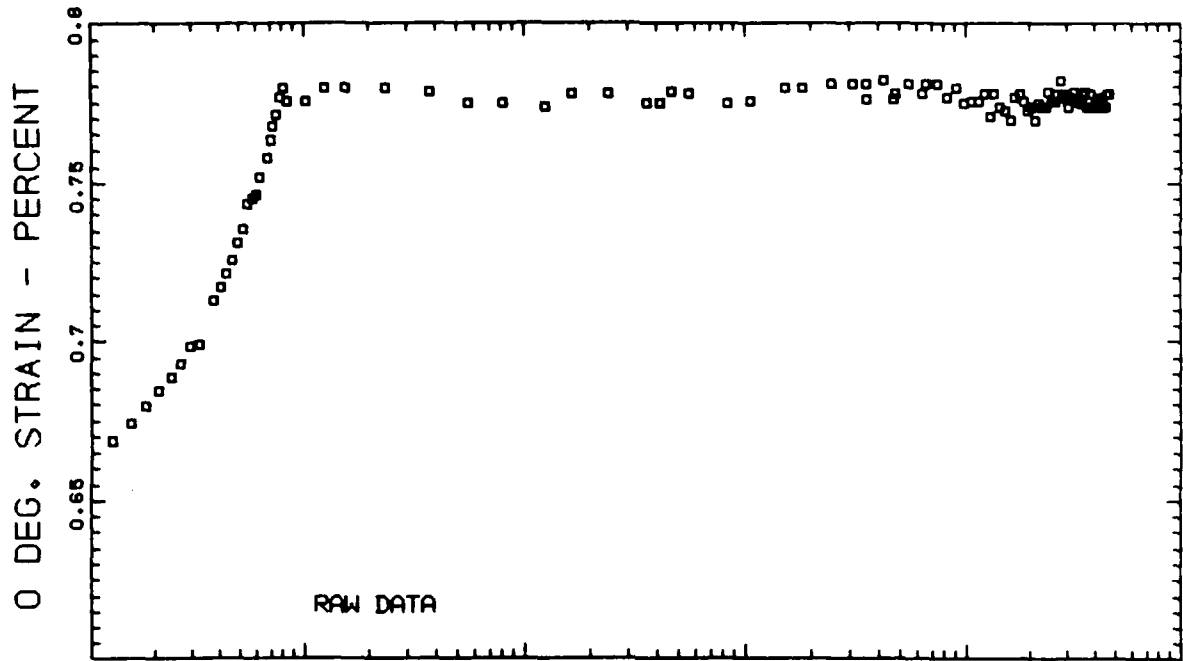

T300/5208 - STEP/RELAXATION - SPECIMEN No. 5 - STEP No. 3

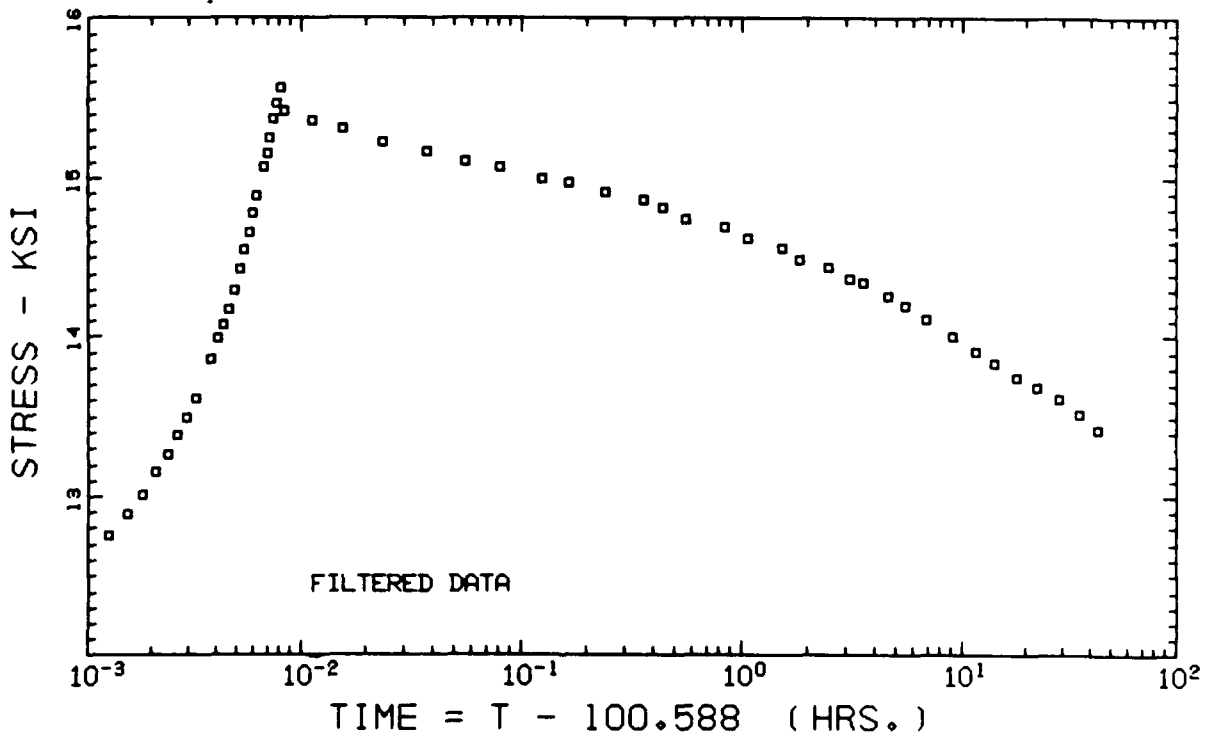
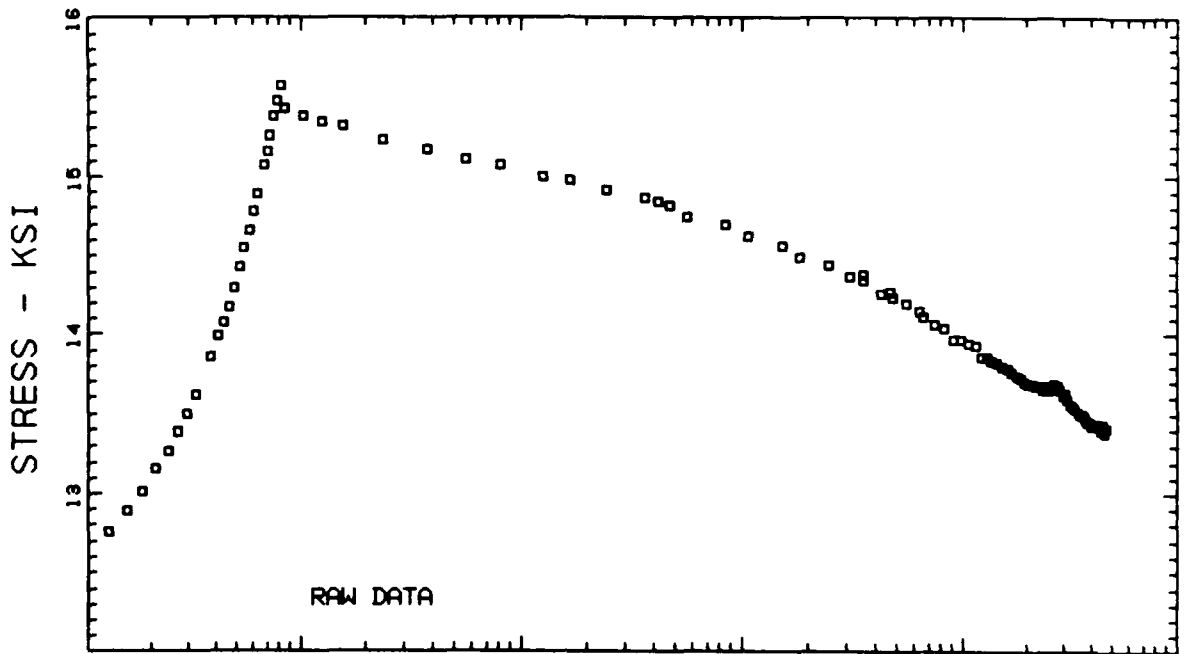

T300/5208 - STEP/RELAXATION - SPECIMEN No. 5 - STEP No. 3

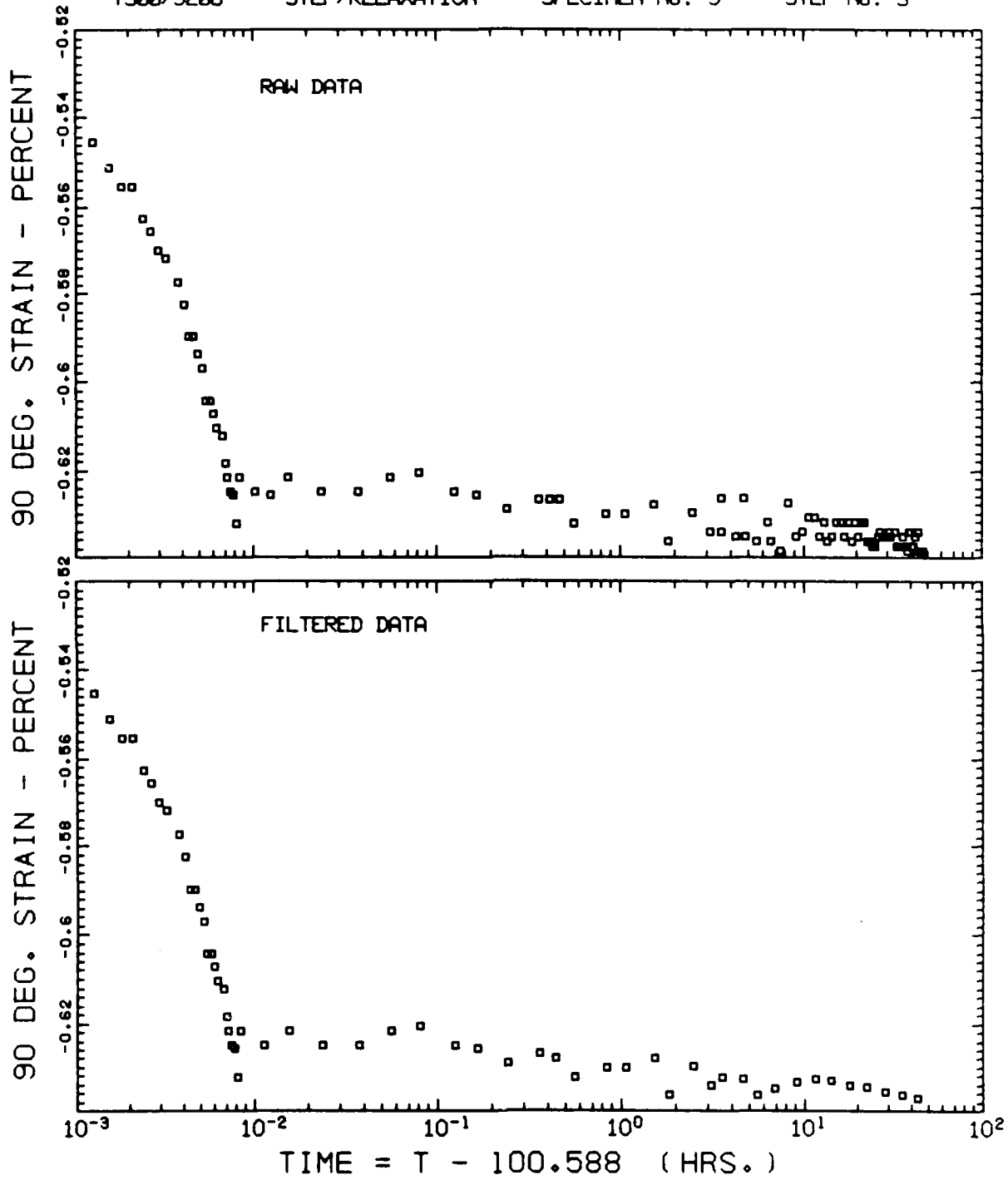

T300/5208 - STEP/RELAXATION - SPECIMEN No. 5 - STEP No. 3

45 DEG. STRAIN - PERCENT

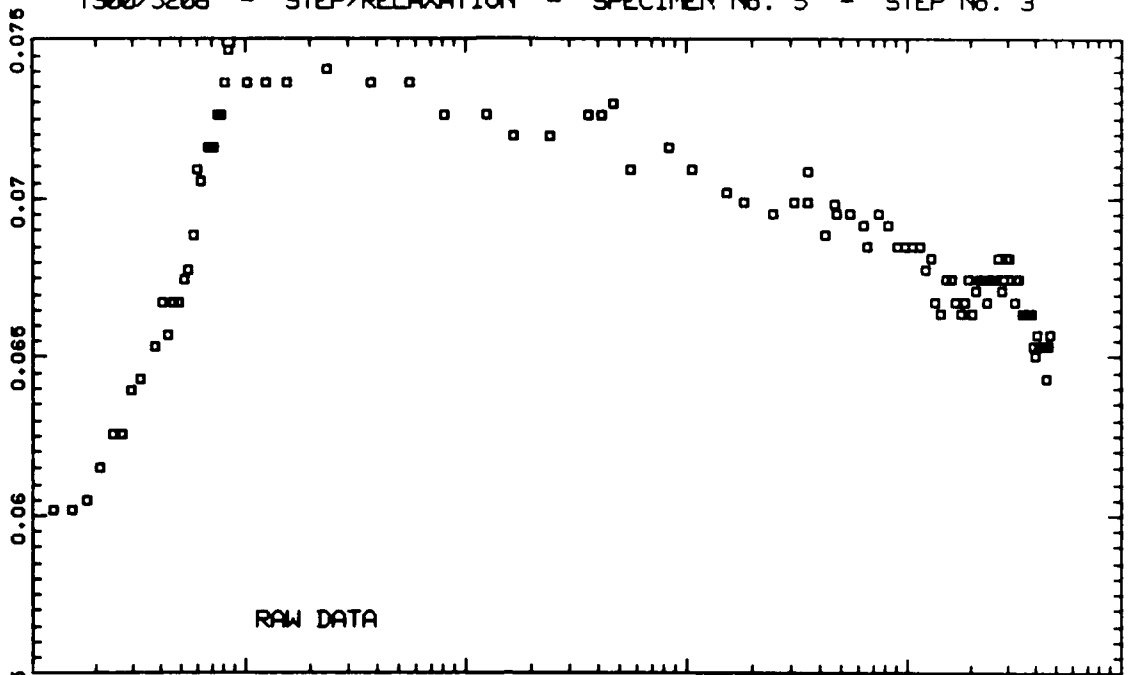

45 DEG. STRAIN - PERCENT

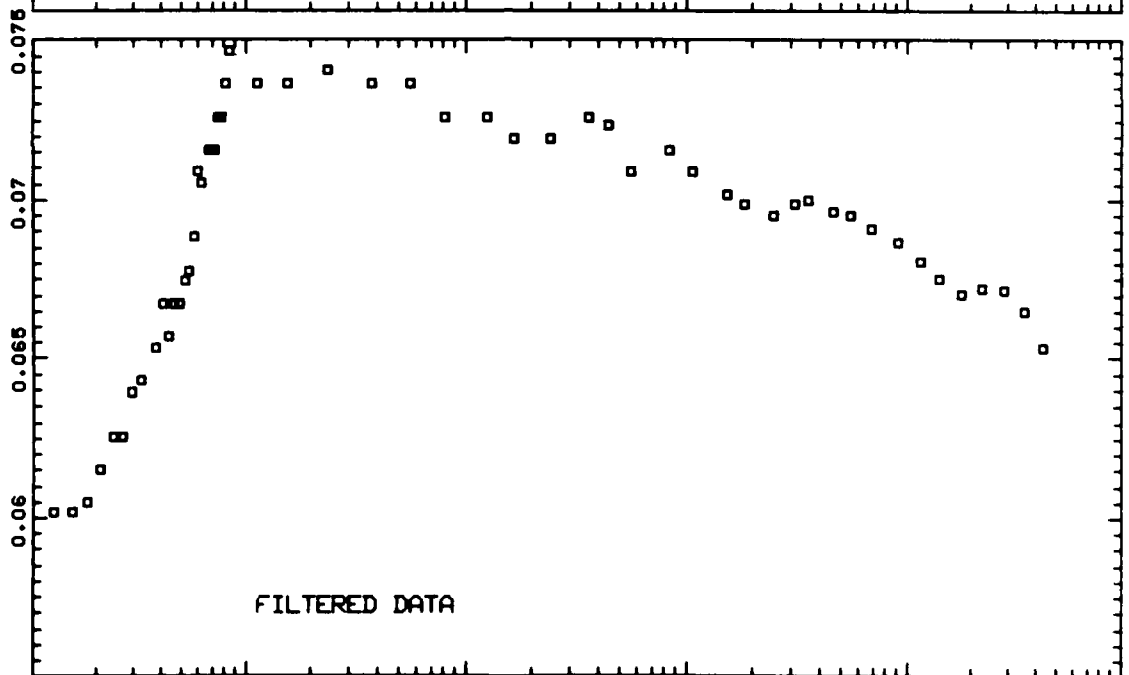

TIME = T - 100.588 (HRS.)

T300/5208 - STEP/RELAXATION - SPECIMEN No. 5 - STEP No. 4

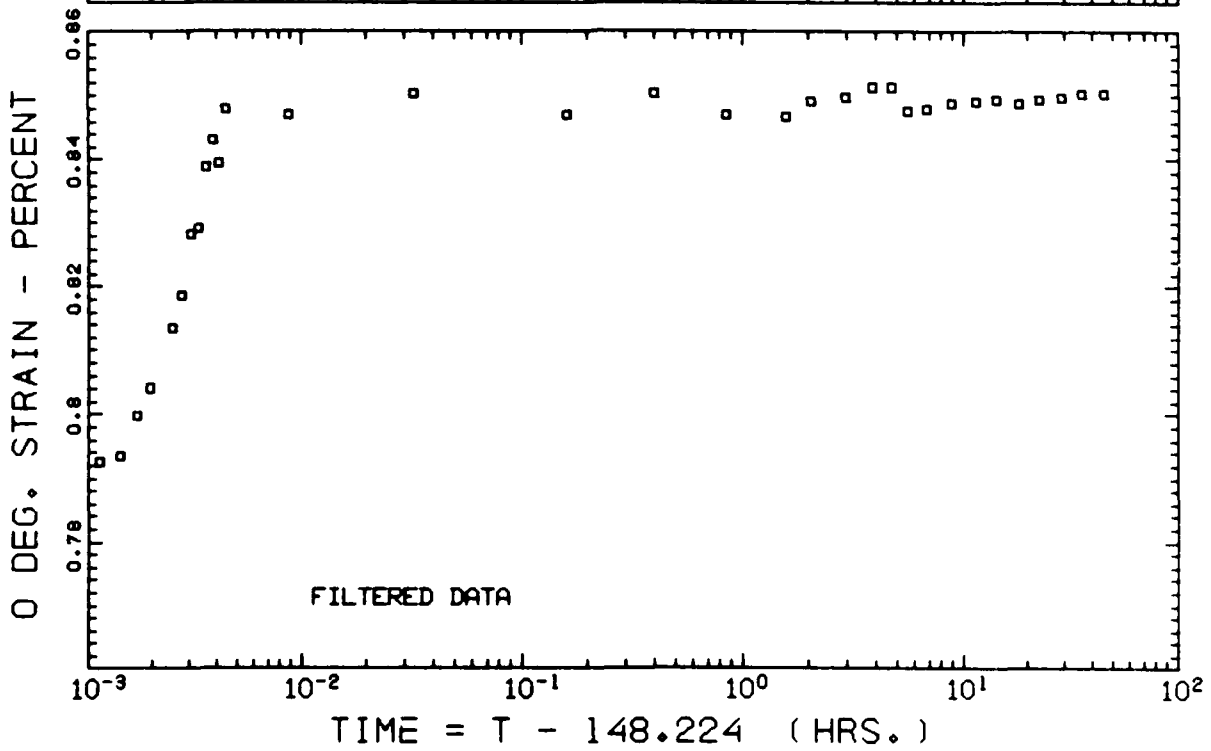
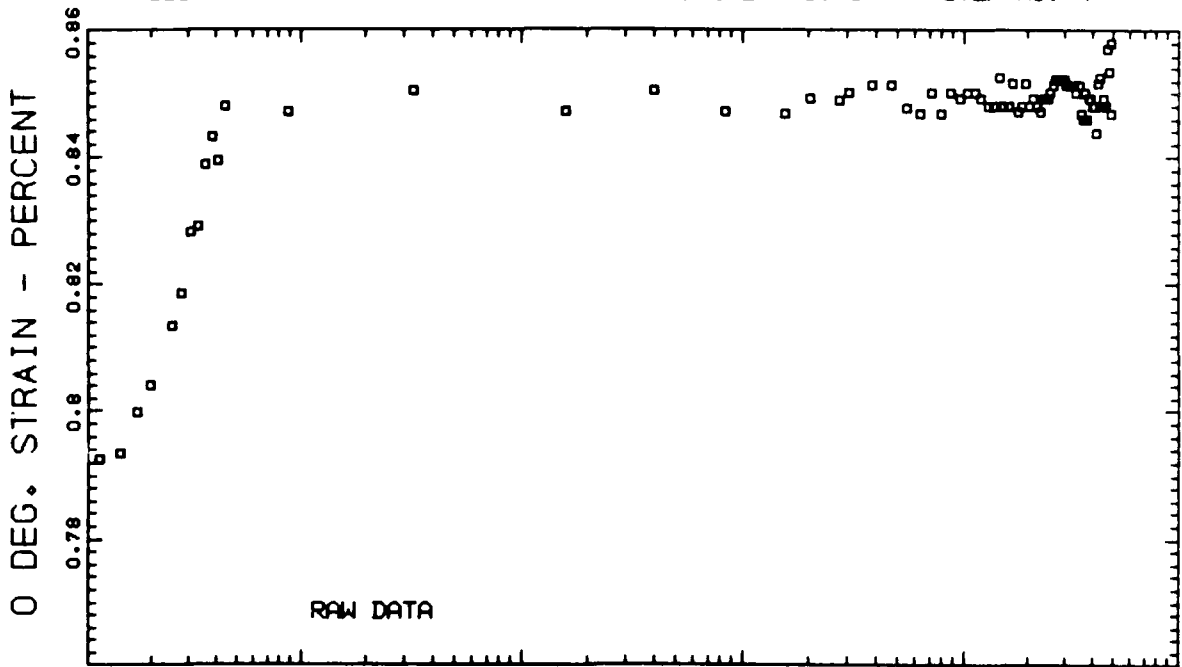



T300/5208 - STEP/RELAXATION - SPECIMEN No. 5 - STEP No. 4

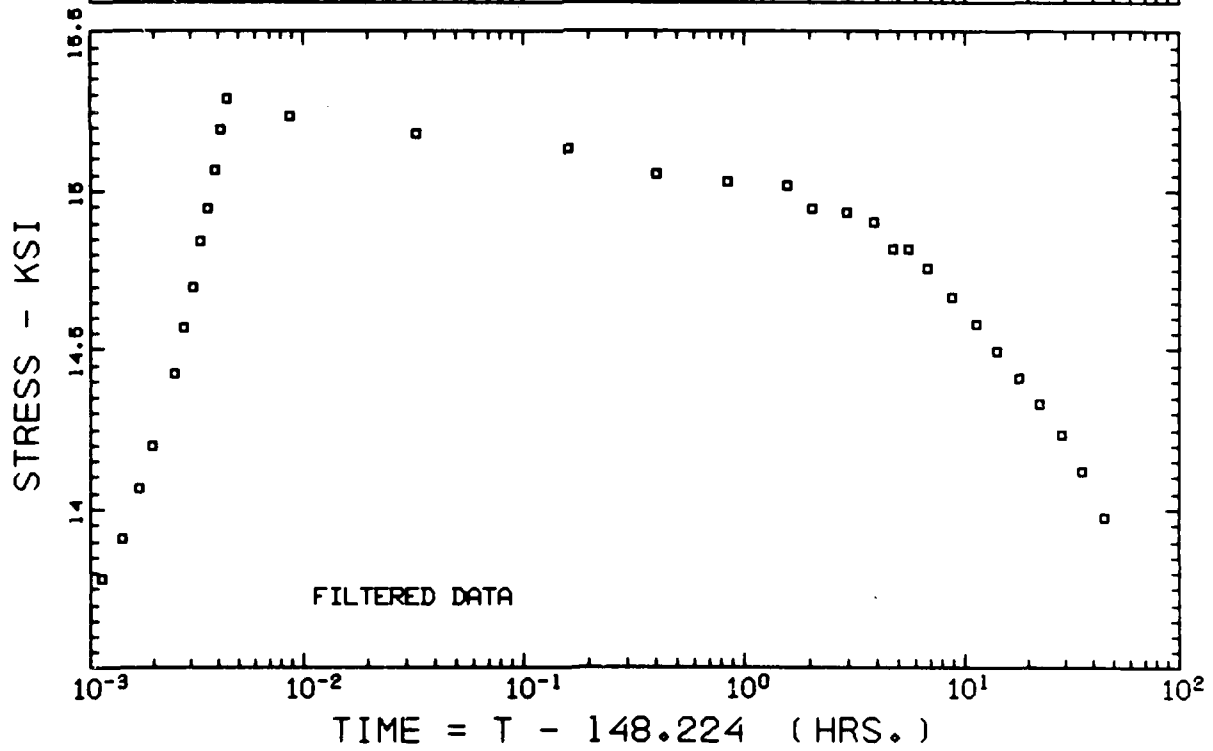
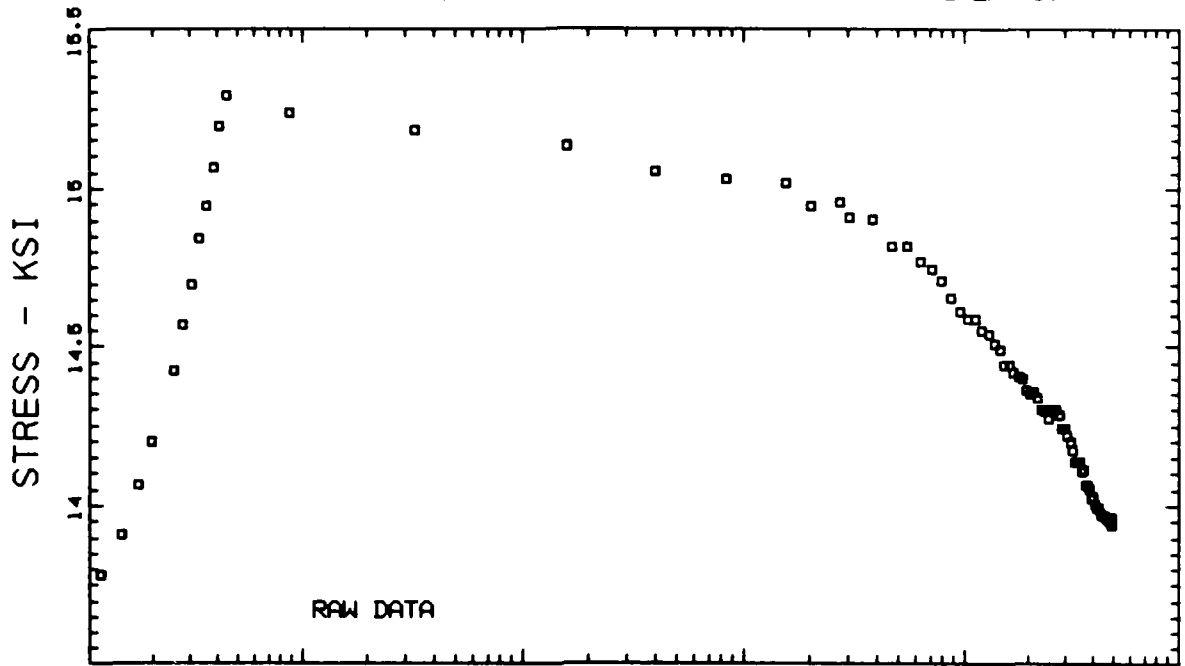

T300/S208 - STEP/RELAXATION - SPECIMEN No. 5 - STEP No. 4

90 DEG. STRAIN - PERCENT

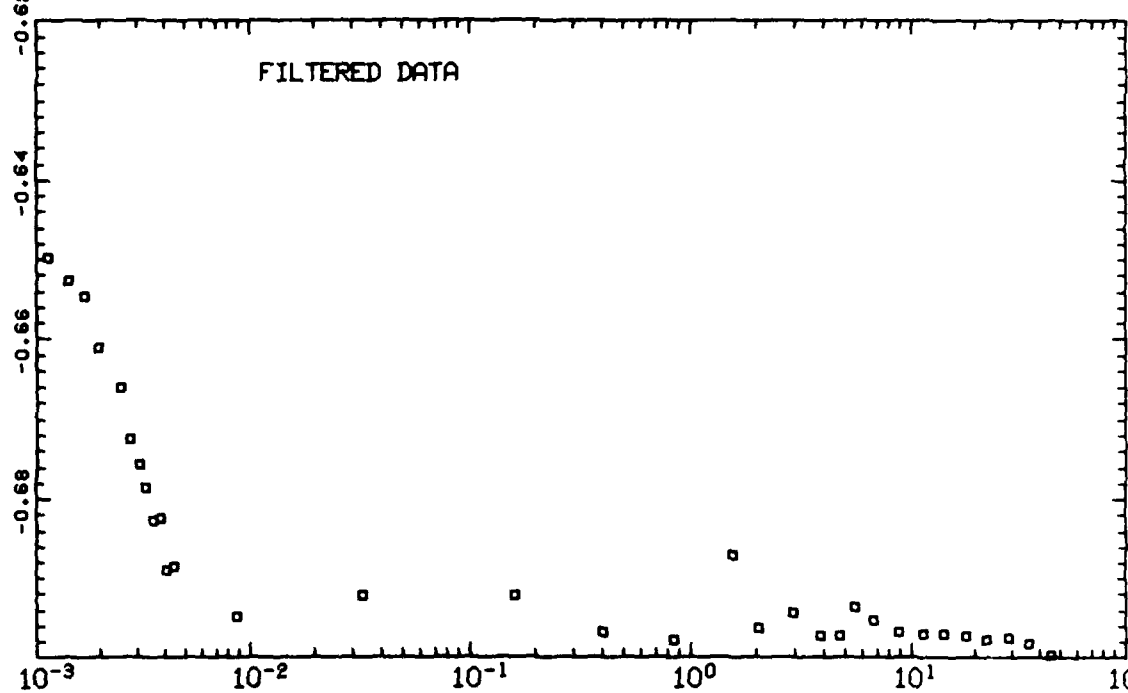
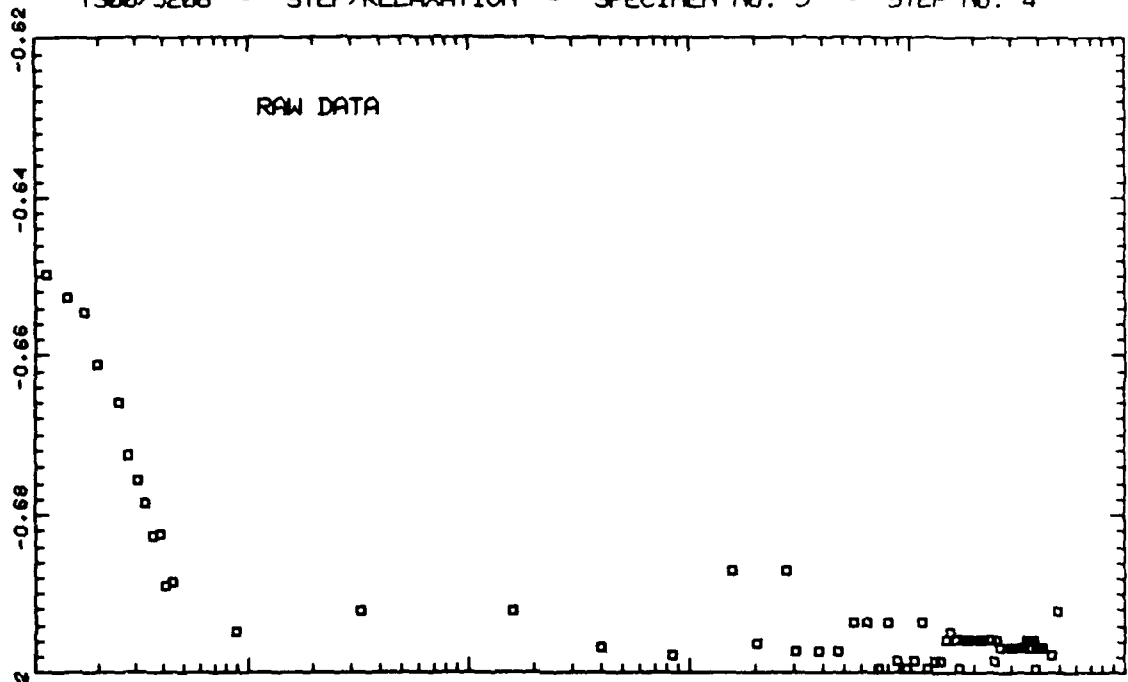

TIME = T - 148.224 (HRS.)

T300/5208 - STEP/RELAXATION - SPECIMEN No. 5 - STEP No. 4

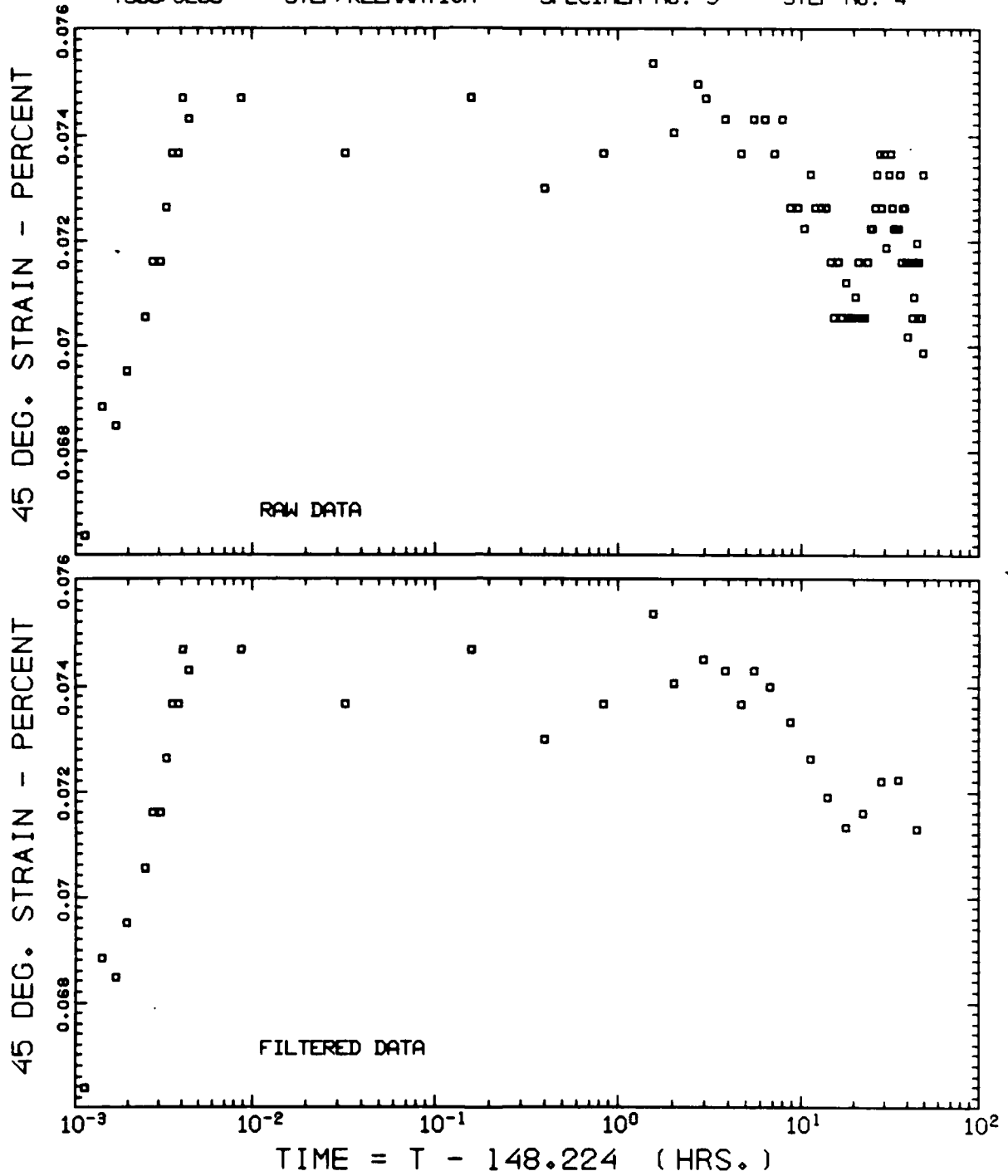

T300/5208 - STEP/RELAXATION - SPECIMEN No. 5 - STEP No. 5

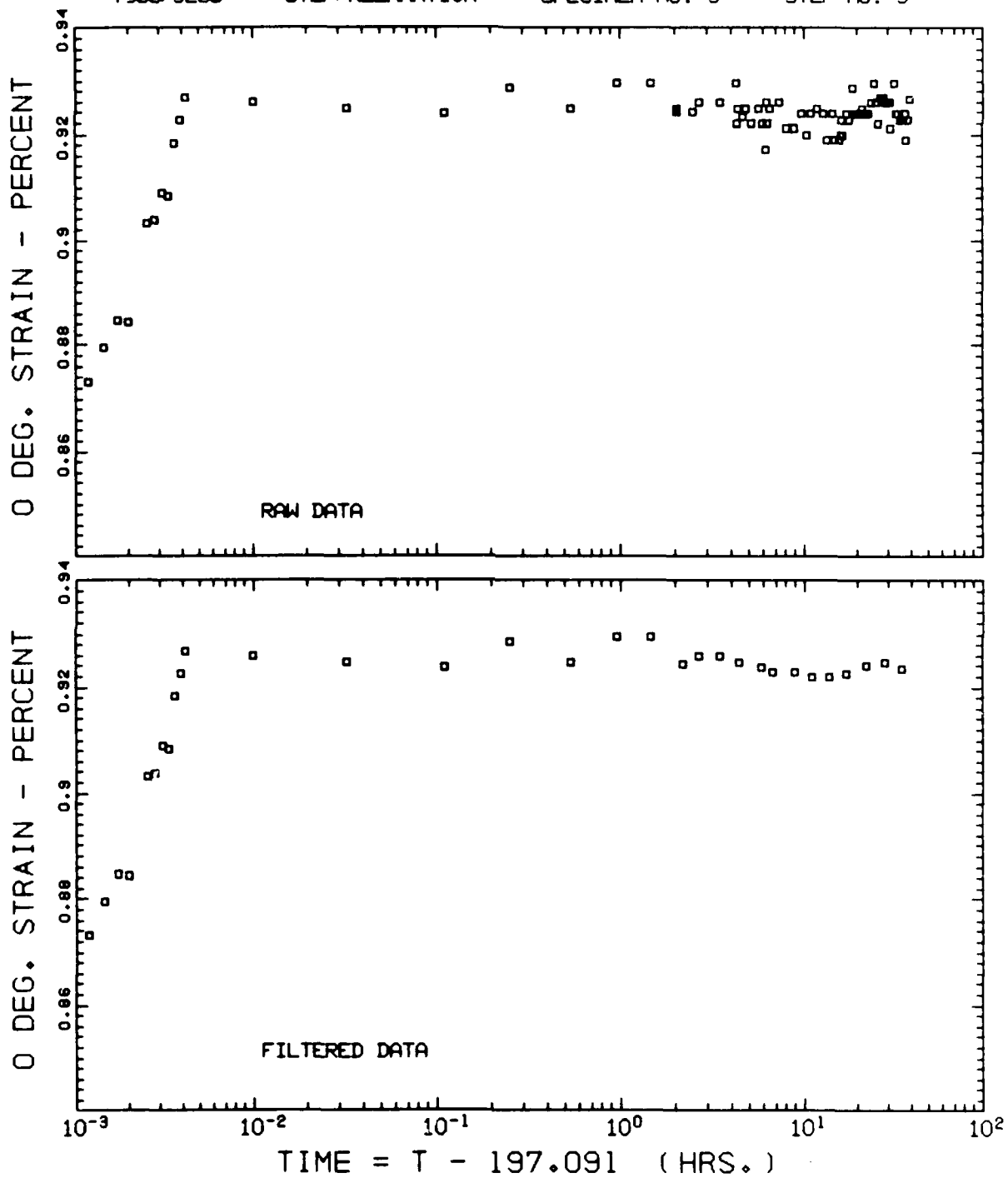

T300/5208 - STEP/RELAXATION - SPECIMEN No. 5 - STEP No. 5

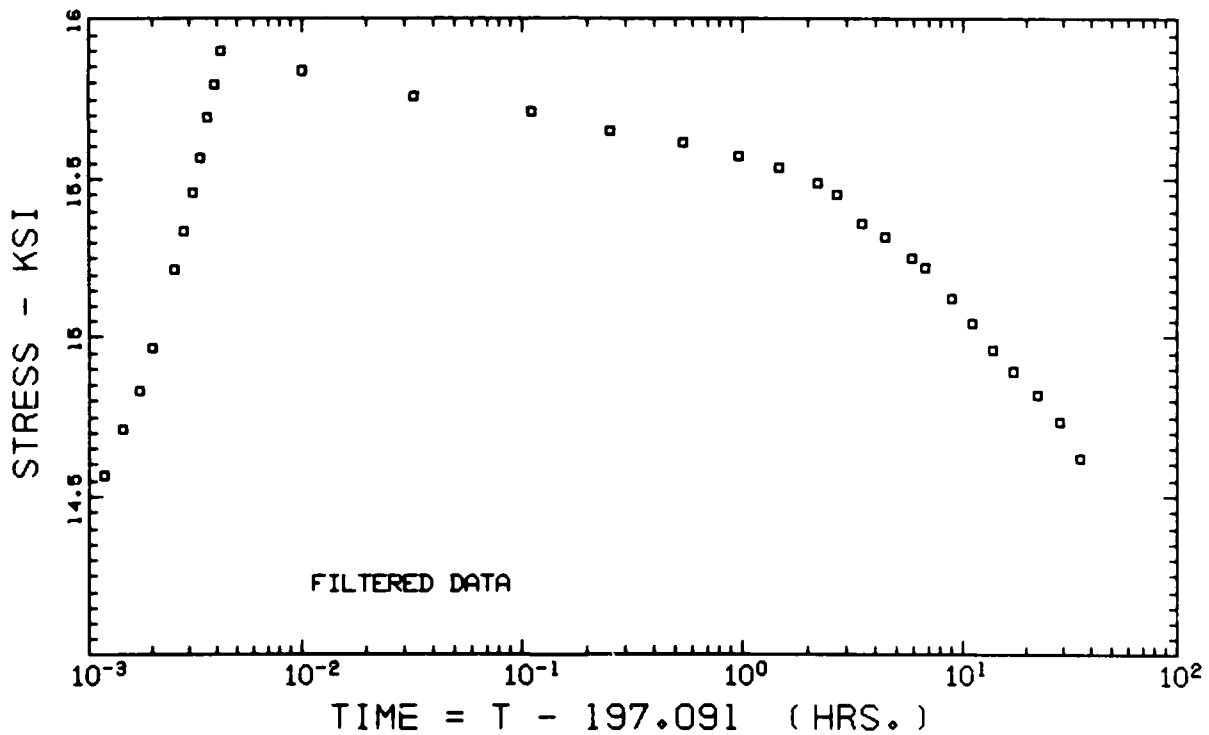
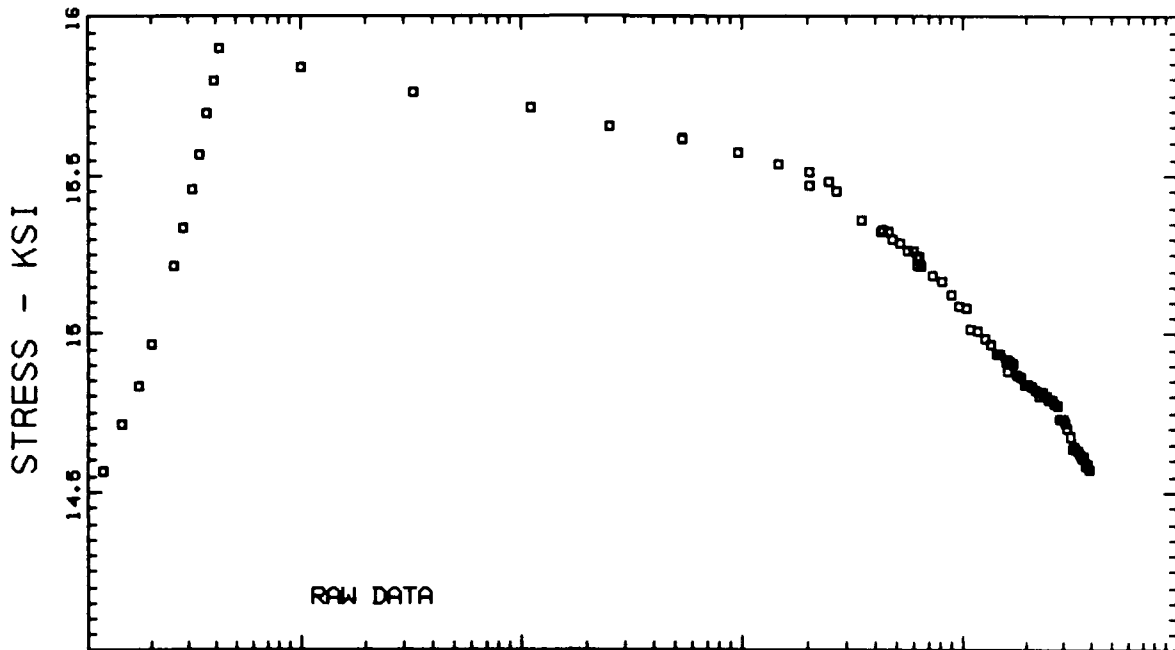

T300/5208 - STEP/RELAXATION - SPECIMEN No. 5 - STEP No. 5

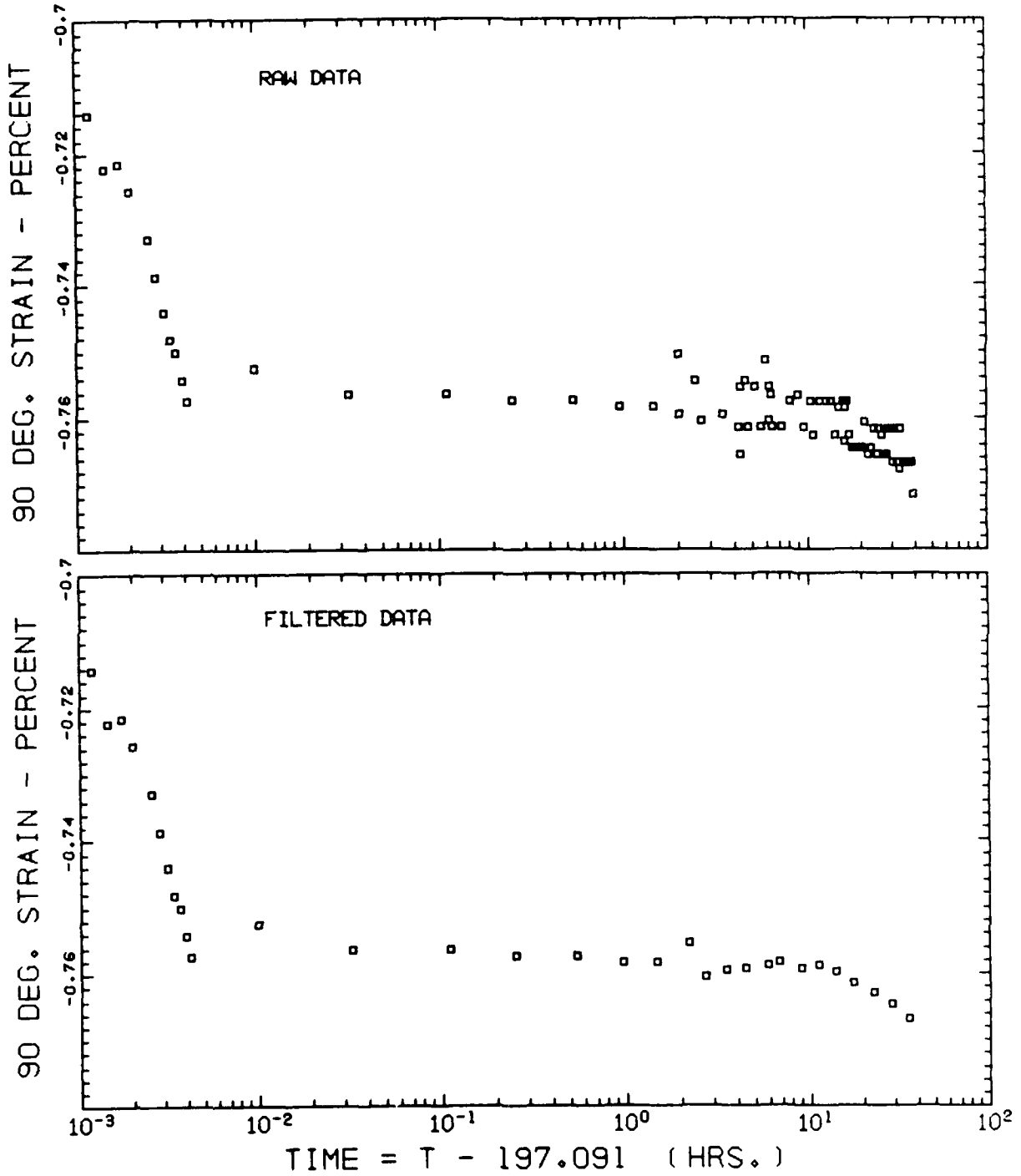

T300/5208 - STEP/RELAXATION - SPECIMEN No. 5 - STEP No. 5

45 DEG. STRAIN - PERCENT

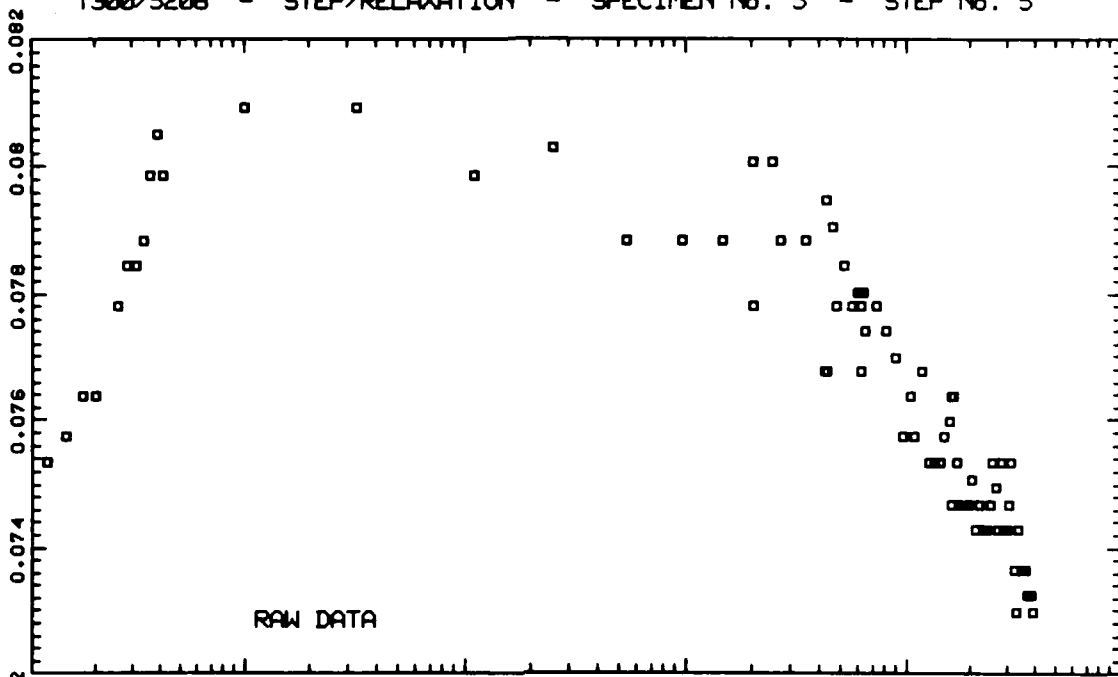

45 DEG. STRAIN - PERCENT

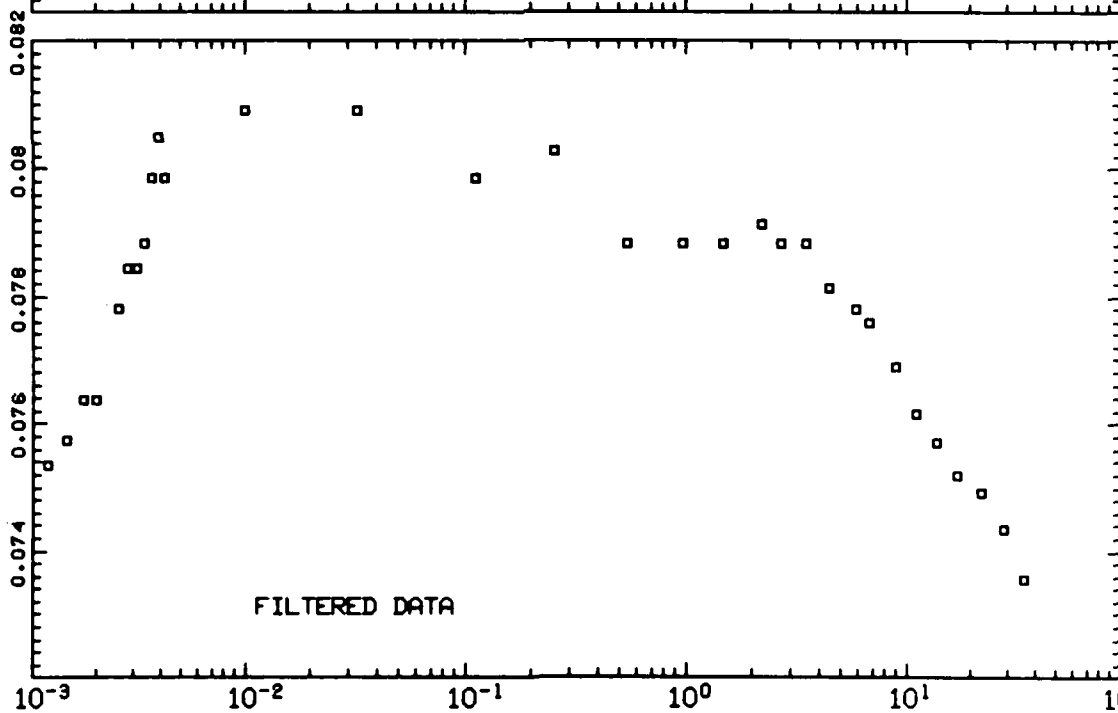

TIME = T - 197.091 (HRS.)

T300/5208 - STEP/RELAXATION - SPECIMEN No. 5 - STEP No. 6

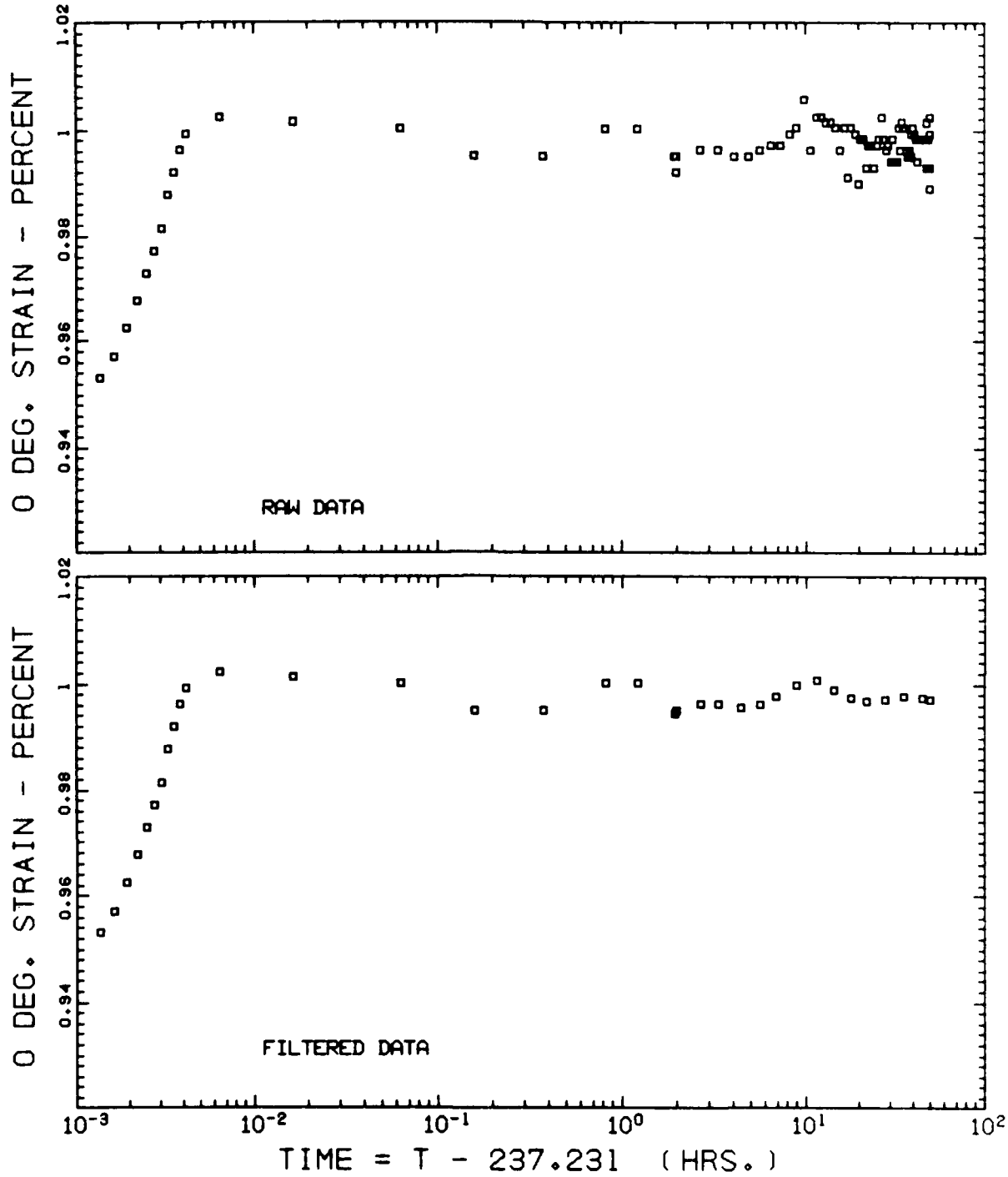



T300/5208 - STEP/RELAXATION - SPECIMEN No. 5 - STEP No. 6

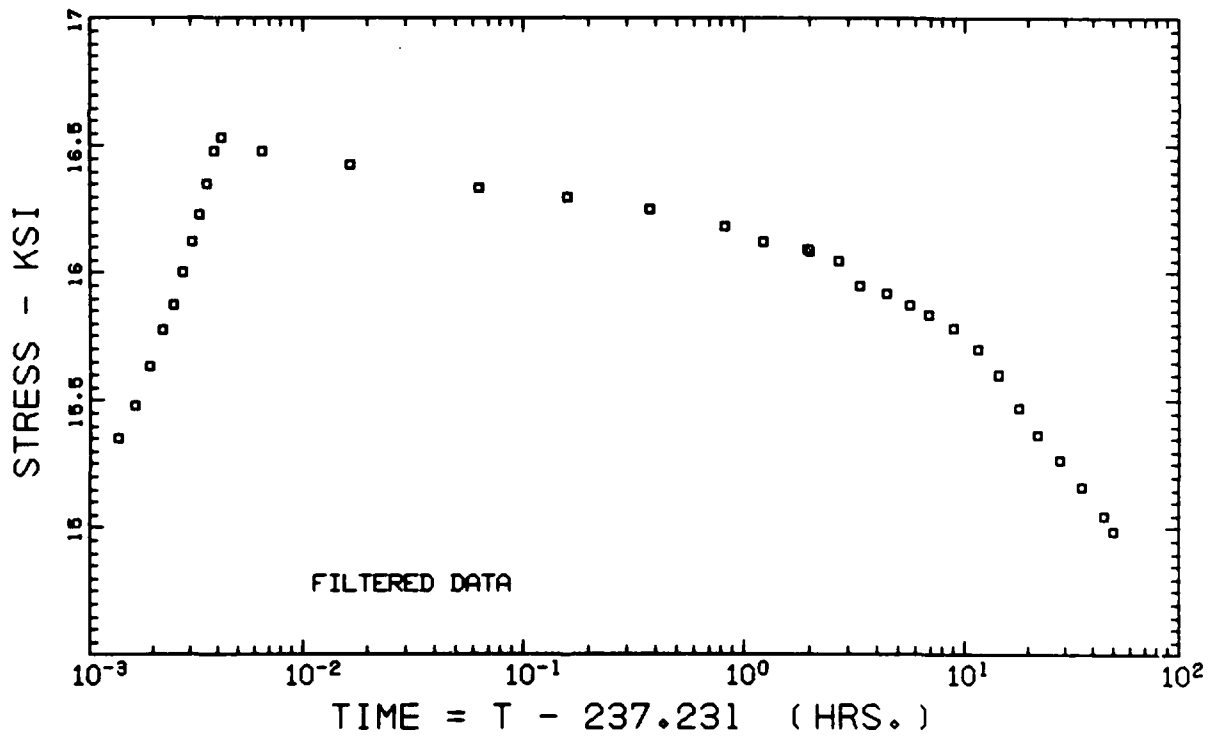
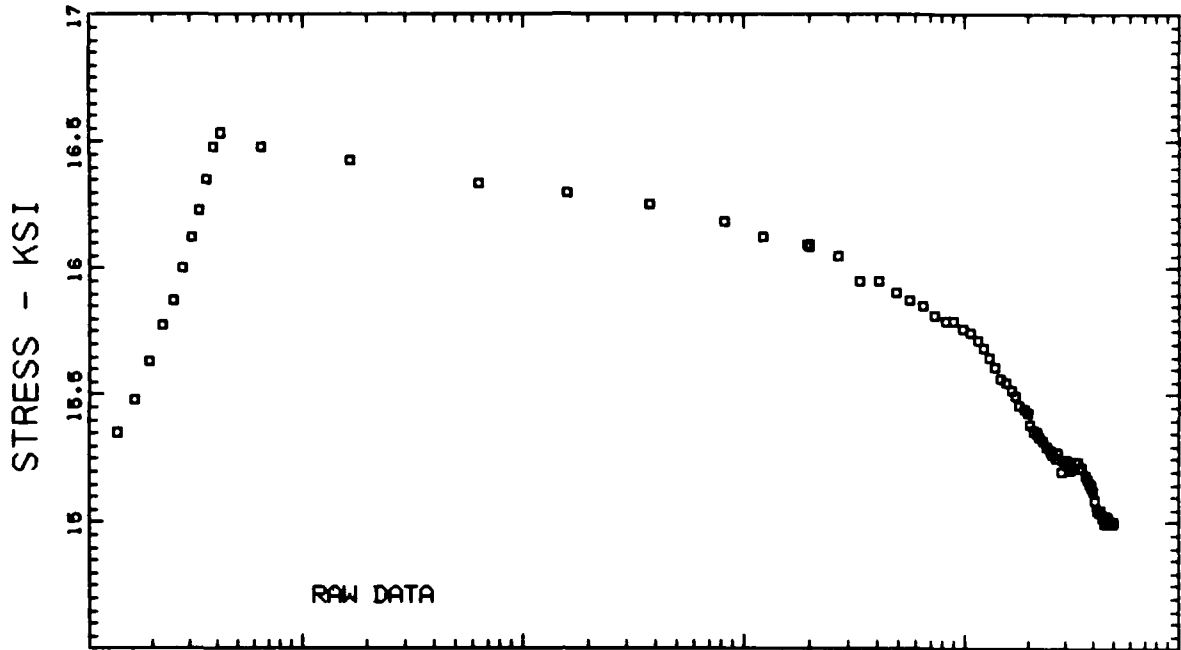

T300/S208 - STEP/RELAXATION - SPECIMEN No. 5 - STEP No. 6

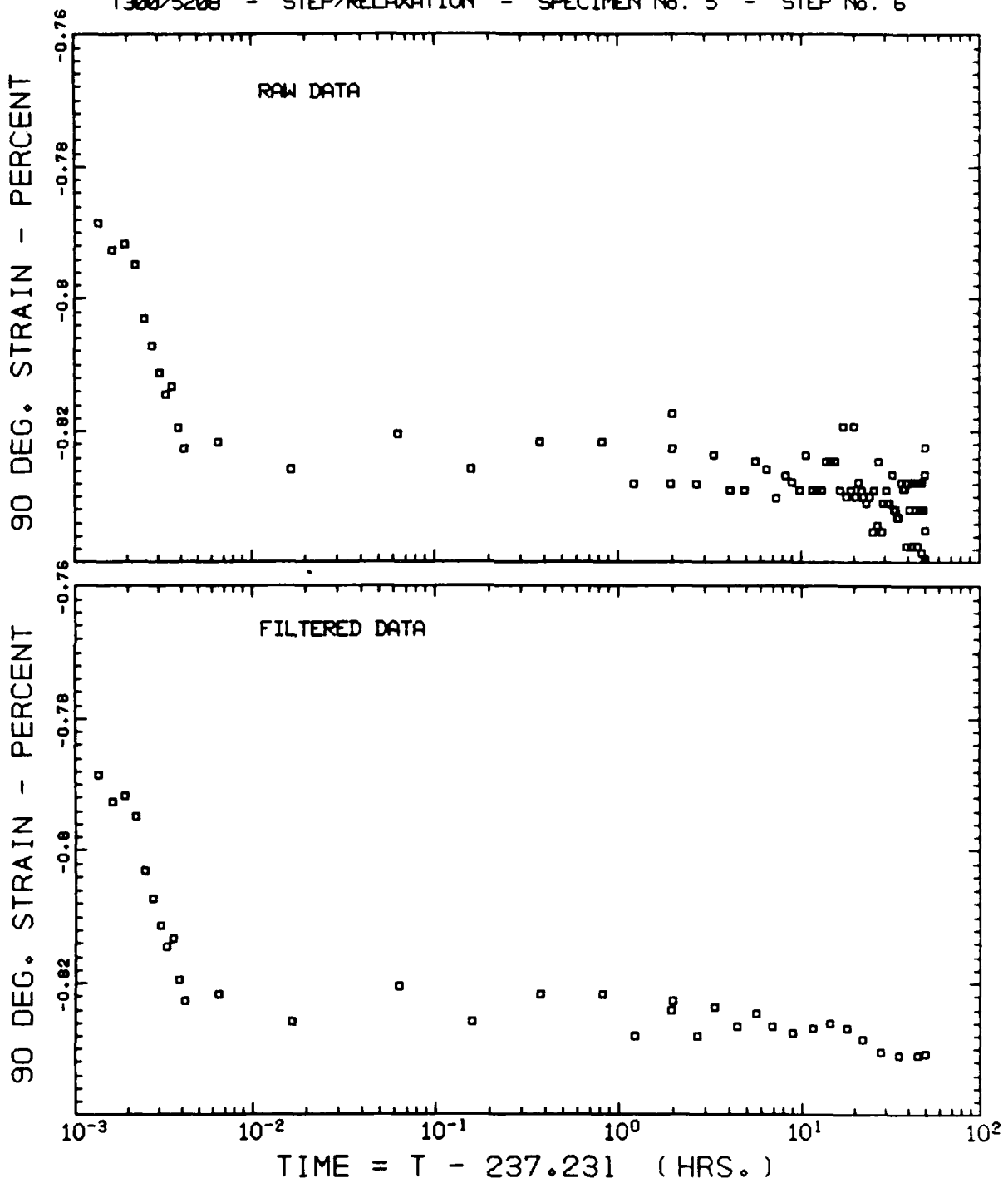

T300/5208 - STEP/RELAXATION - SPECIMEN No. 5 - STEP No. 6

45 DEG. STRAIN - PERCENT

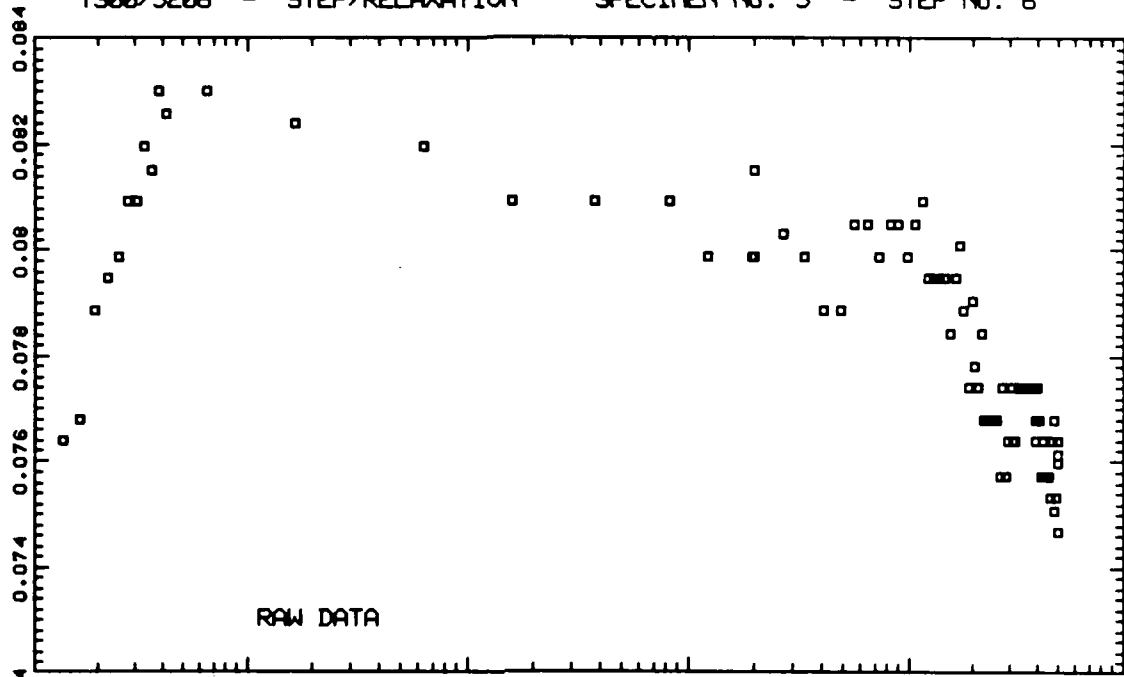

45 DEG. STRAIN - PERCENT

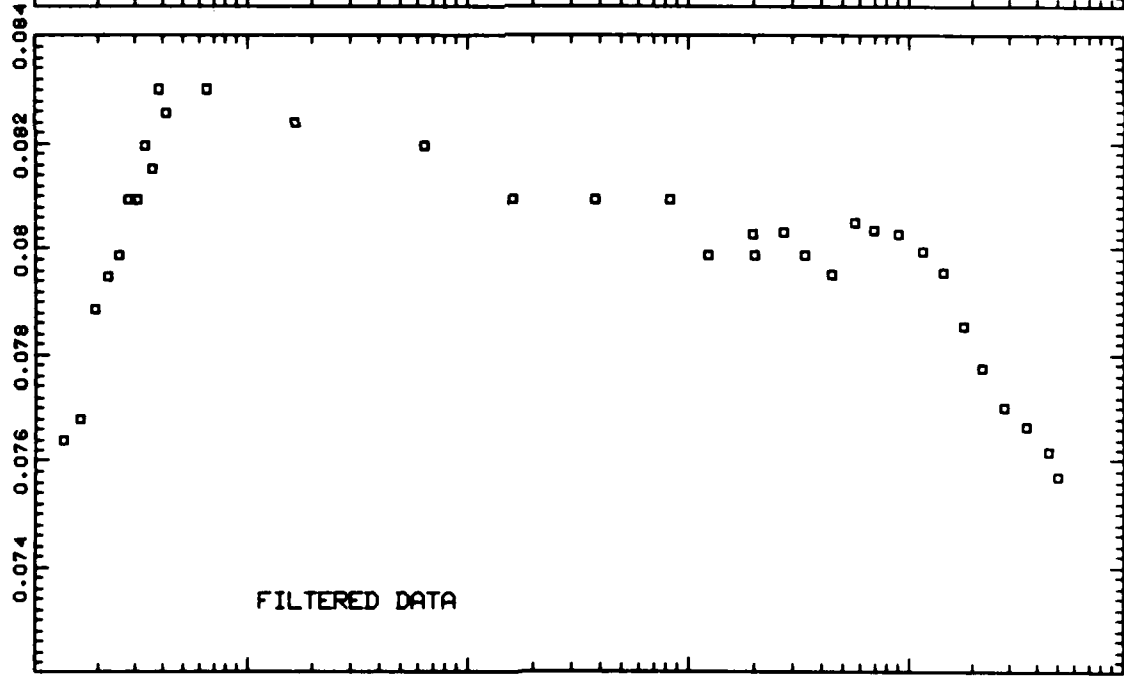

TIME = T - 237.231 (HRS.)

T300/5208 - STEP/RELAXATION - SPECIMEN No. 5 - STEP No. 7

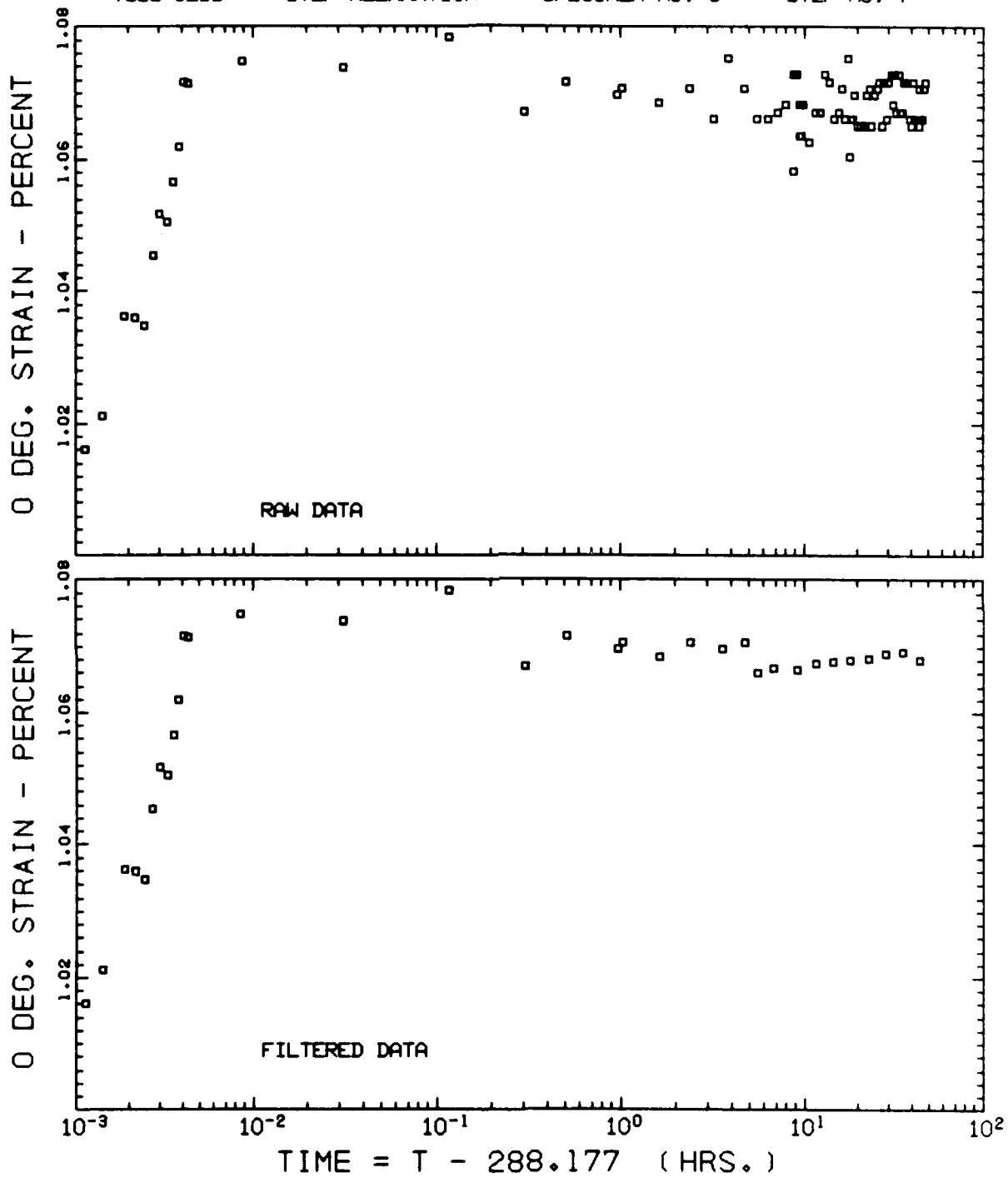

T300/5208 - STEP/RELAXATION - SPECIMEN No. 5 - STEP No. 7

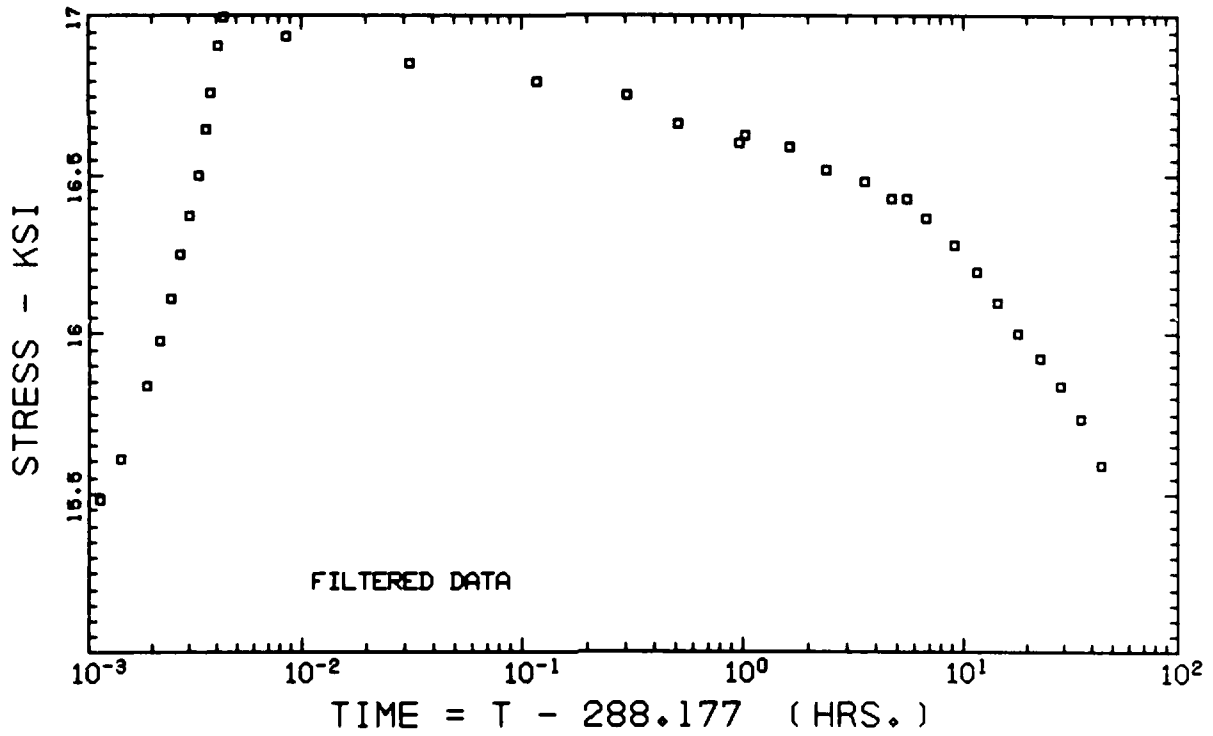
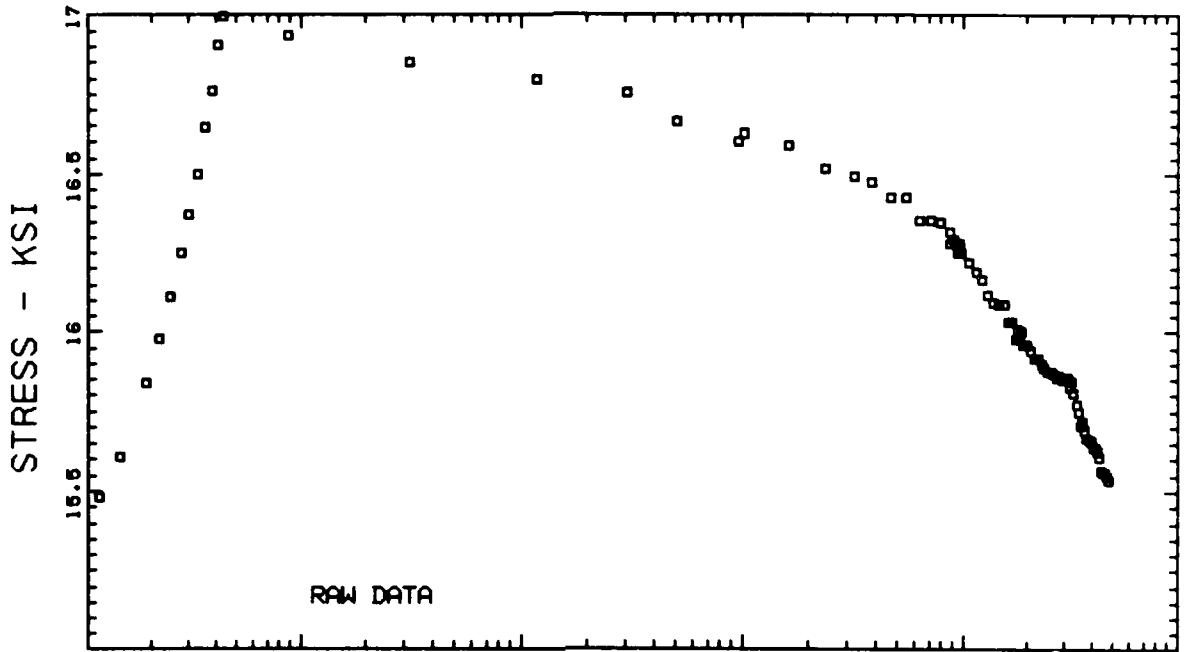

T300/5208 - STEP/RELAXATION - SPECIMEN No. 5 - STEP No. 7

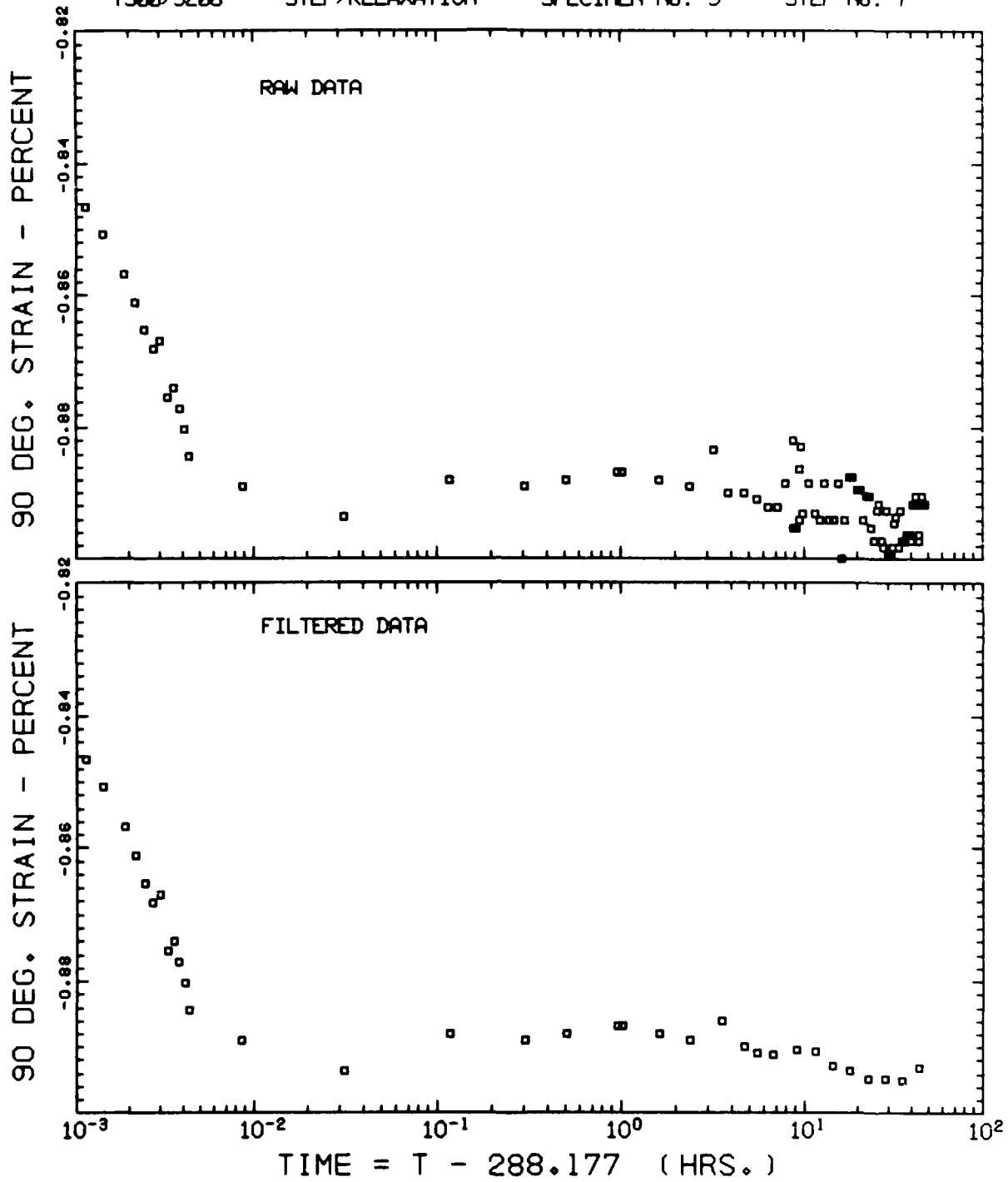

T300/5208 - STEP/RELAXATION - SPECIMEN No. 5 - STEP No. 7

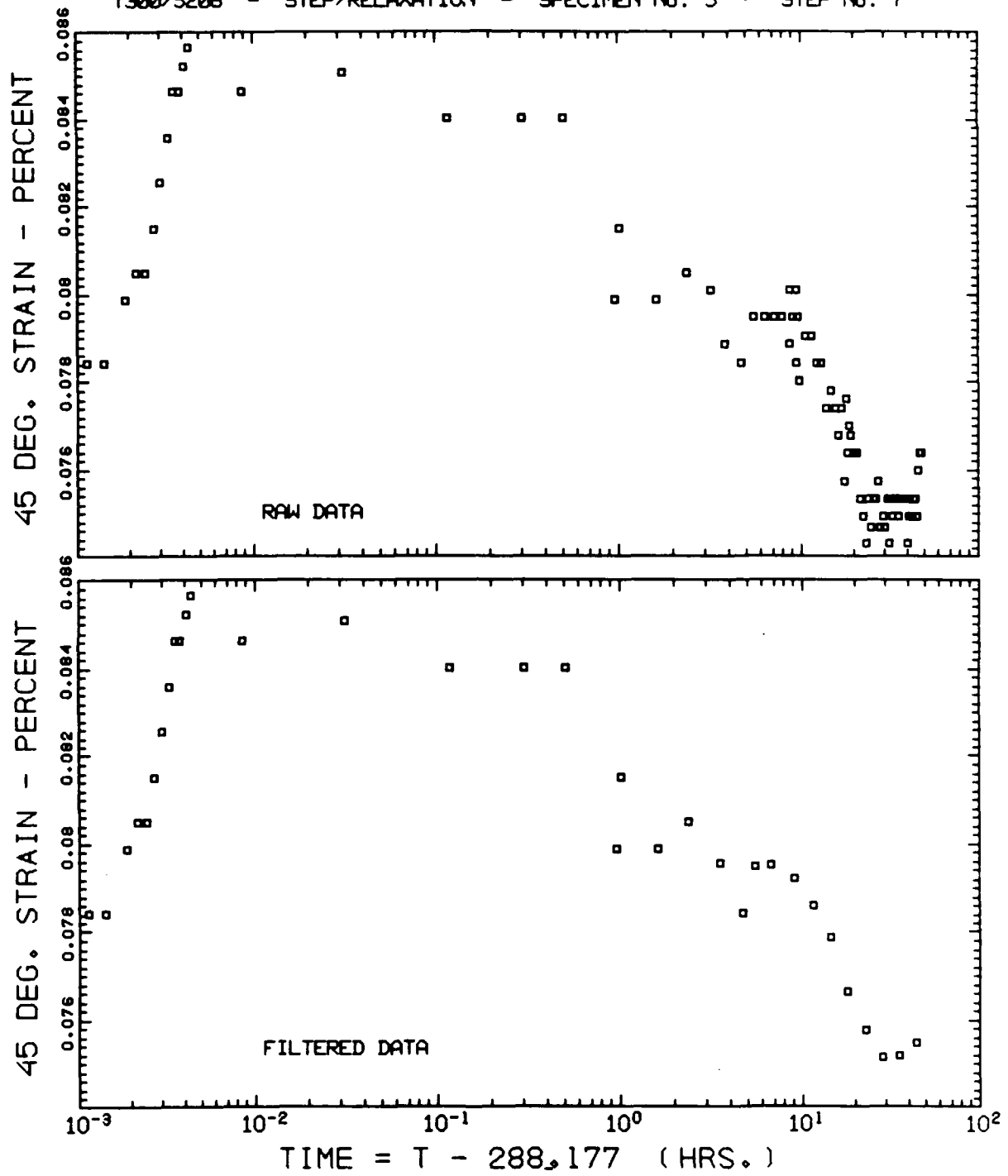

T300/5208 - STEP/RELAXATION - SPECIMEN No. 5 - STEP No. 8

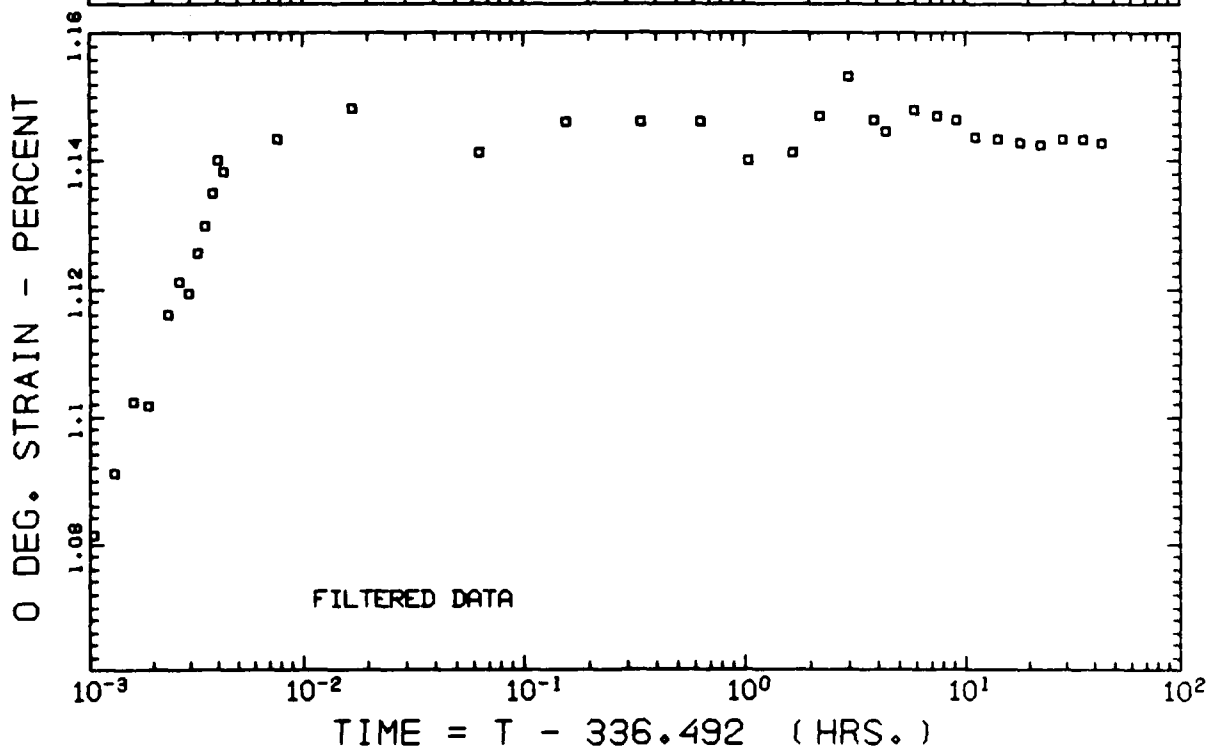
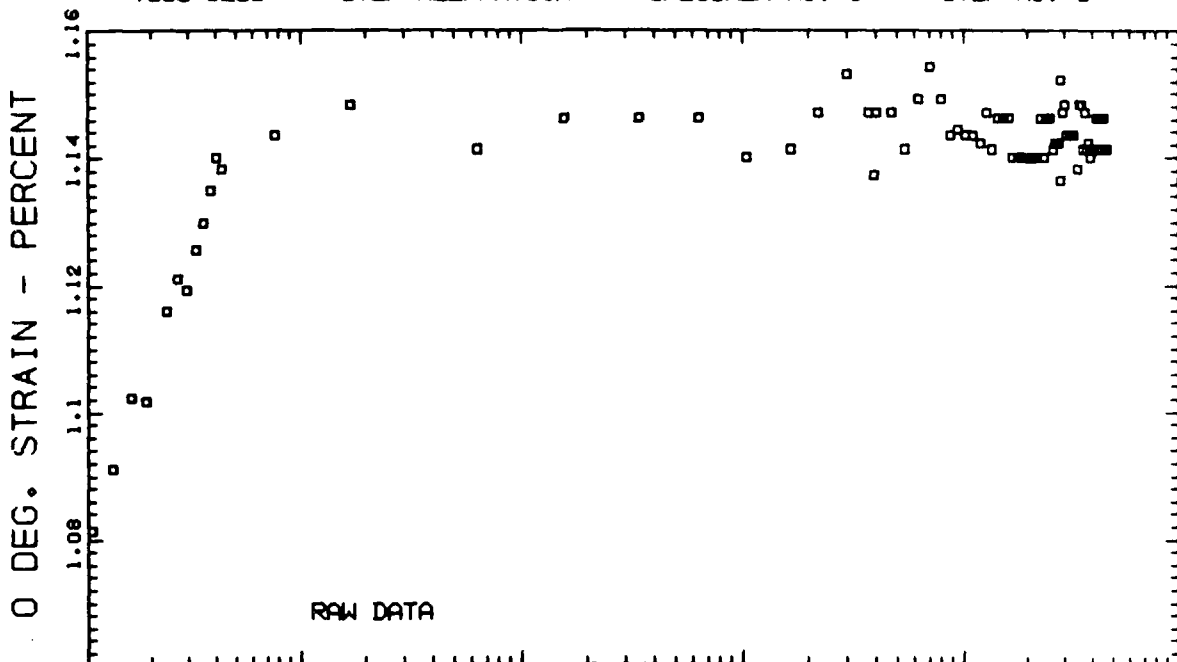



T300/5208 - STEP/RELAXATION - SPECIMEN No. 5 - STEP No. 8

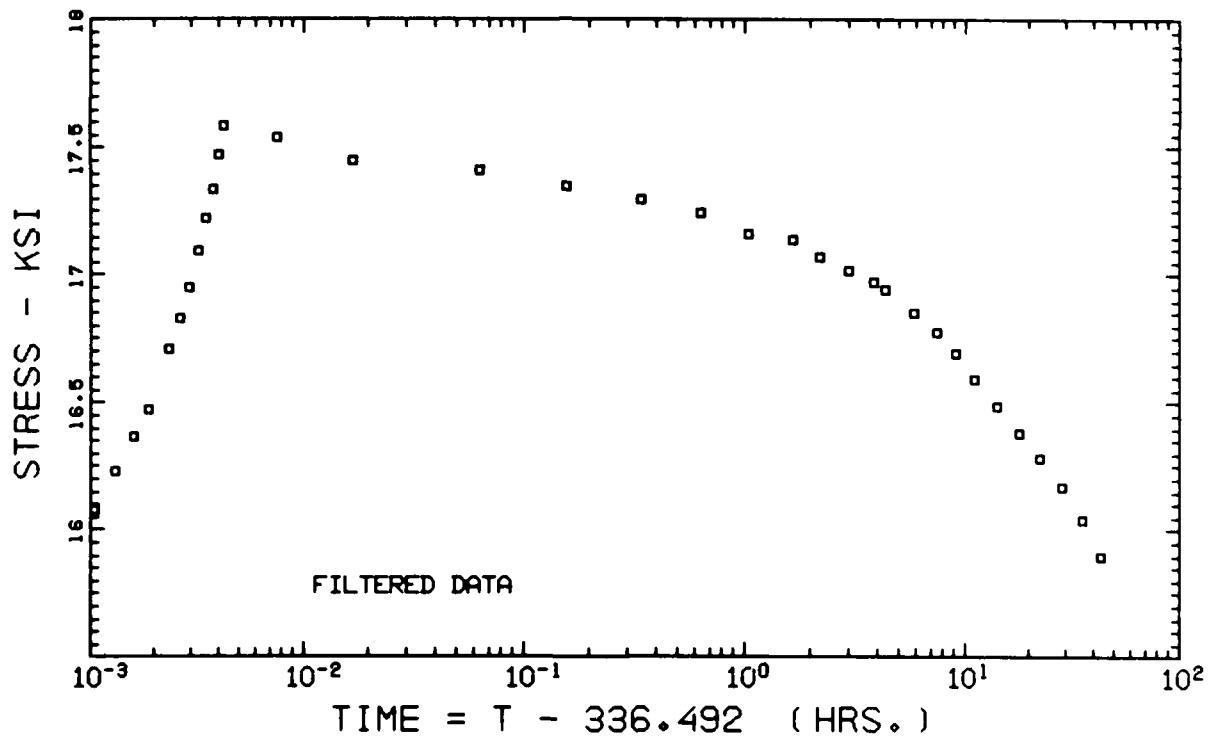
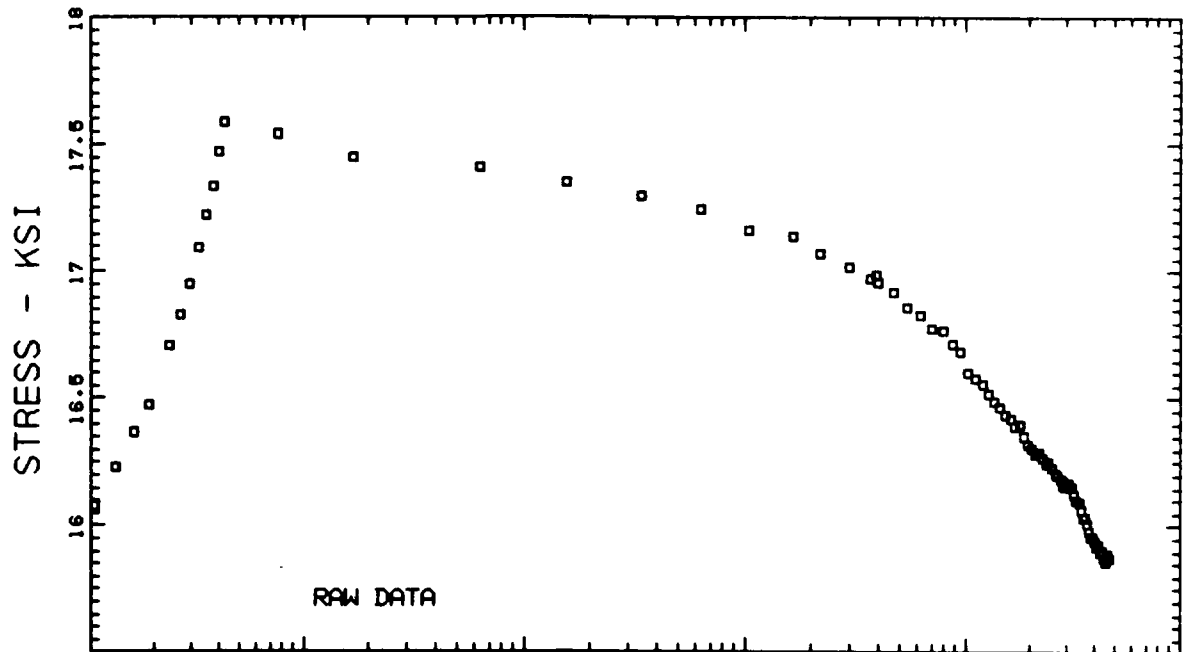

T300/5208 - STEP/RELAXATION - SPECIMEN No. 5 - STEP No. 8

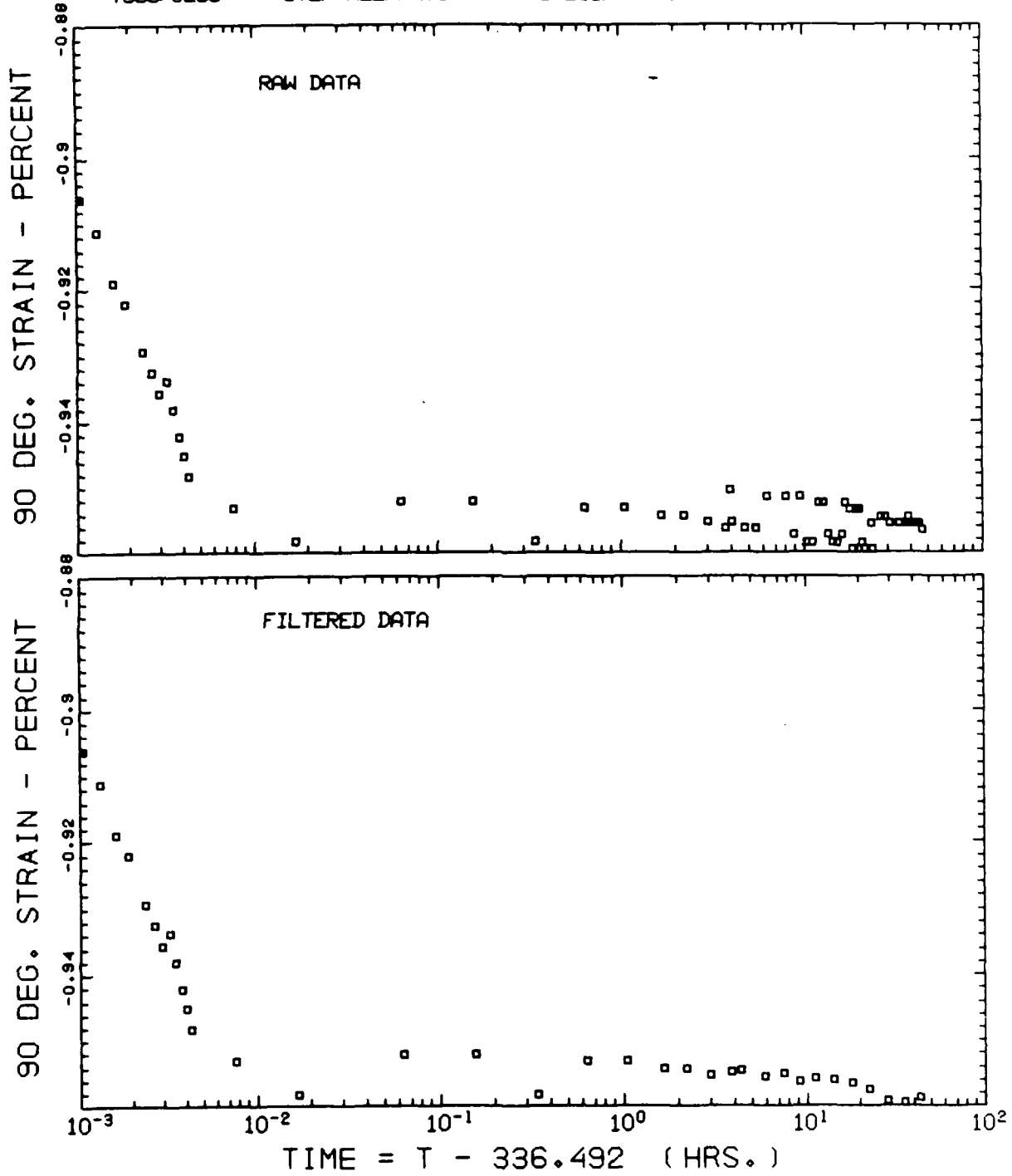

T300/5208 - STEP/RELAXATION - SPECIMEN No. 5 - STEP No. 8

45 DEG. STRAIN - PERCENT

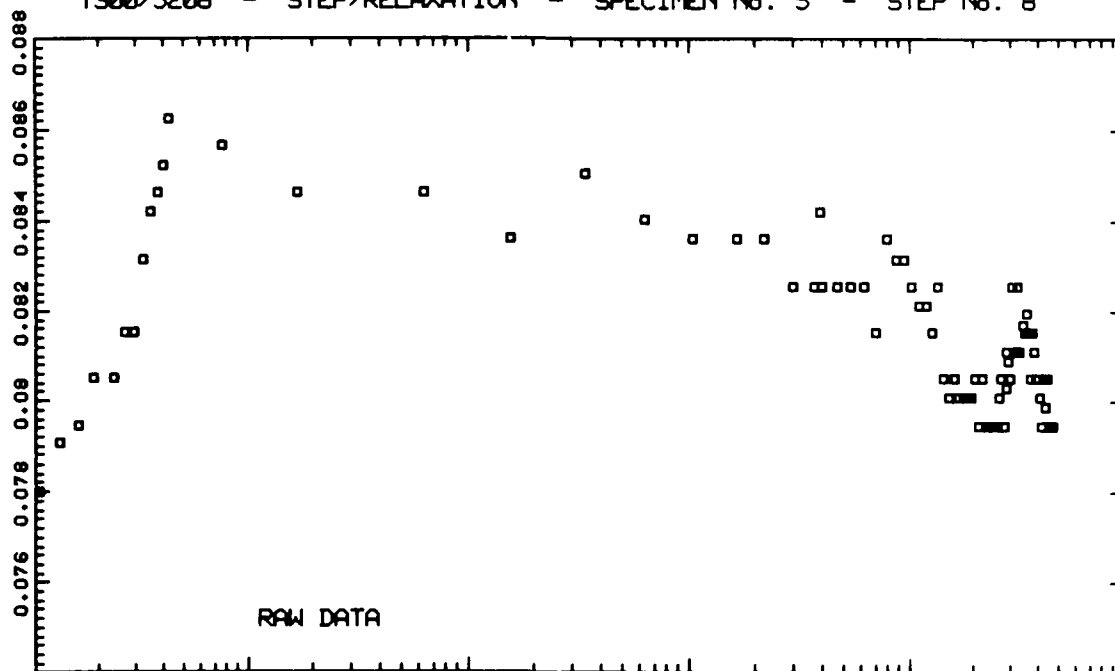

45 DEG. STRAIN - PERCENT

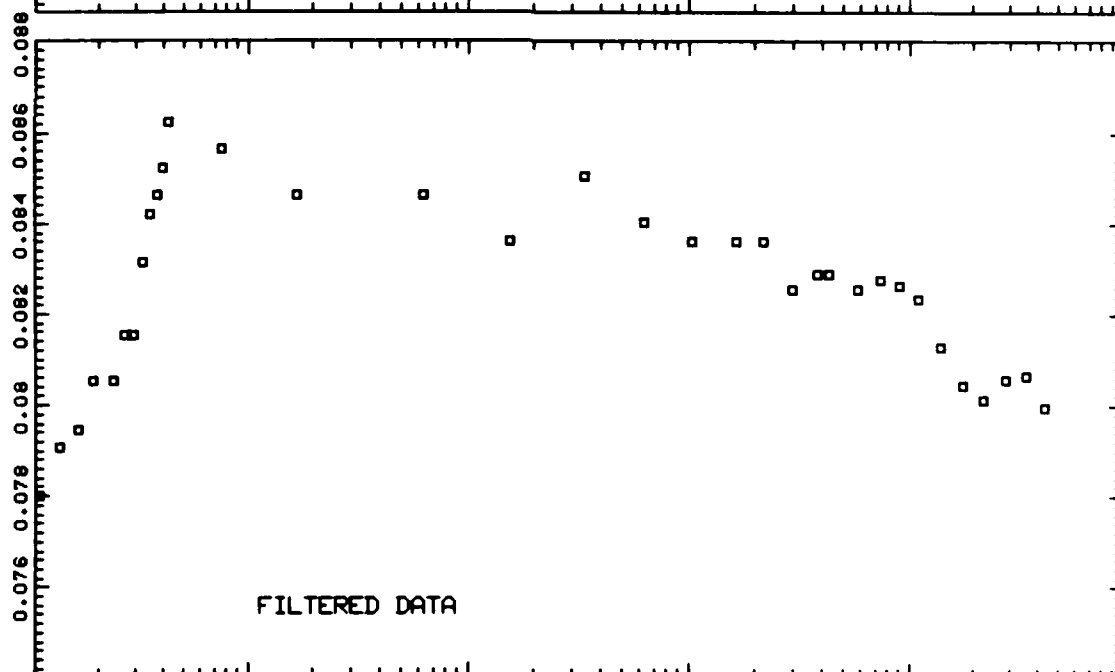

TIME = T - 336.492 (HRS.)

T300/5208 - STEP/RELAXATION - SPECIMEN No. 5 - STEP No. 9

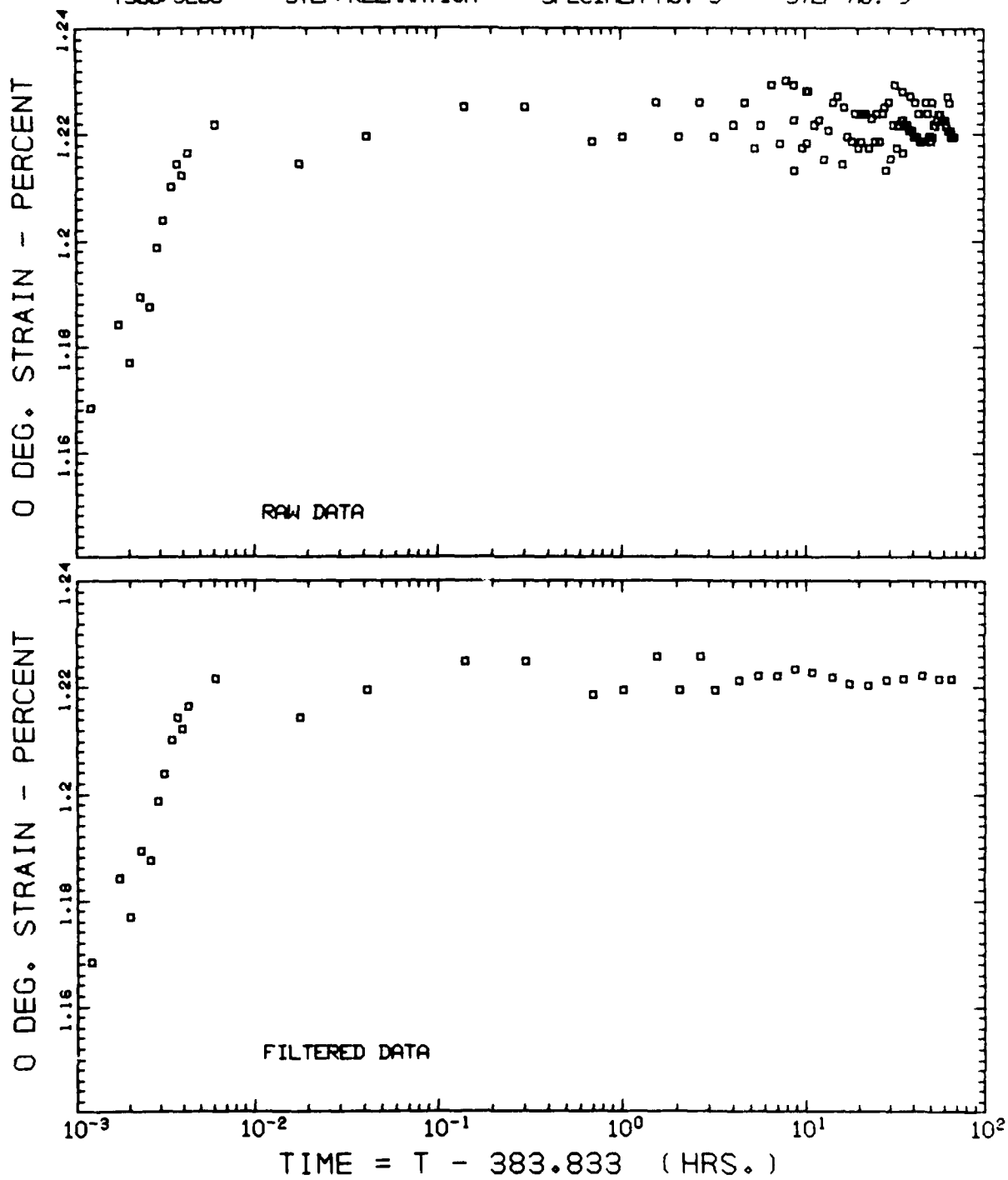

T300/5208 - STEP/RELAXATION - SPECIMEN No. 5 - STEP No. 9

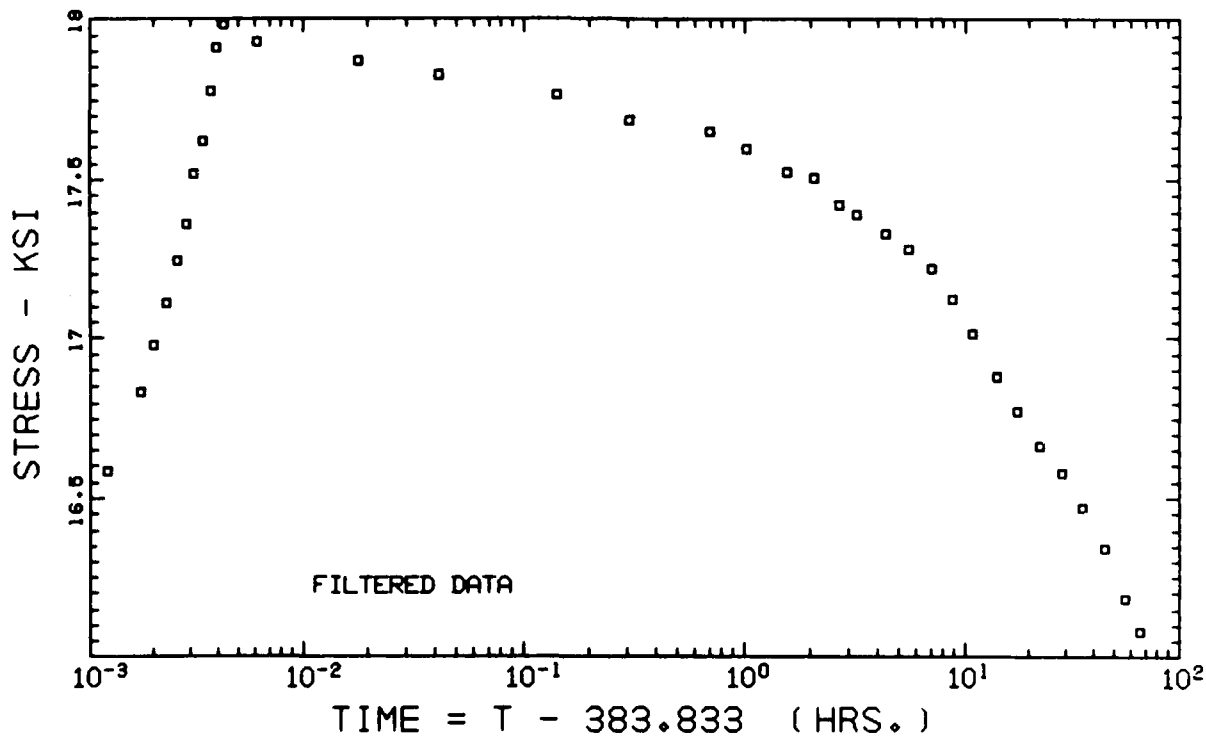
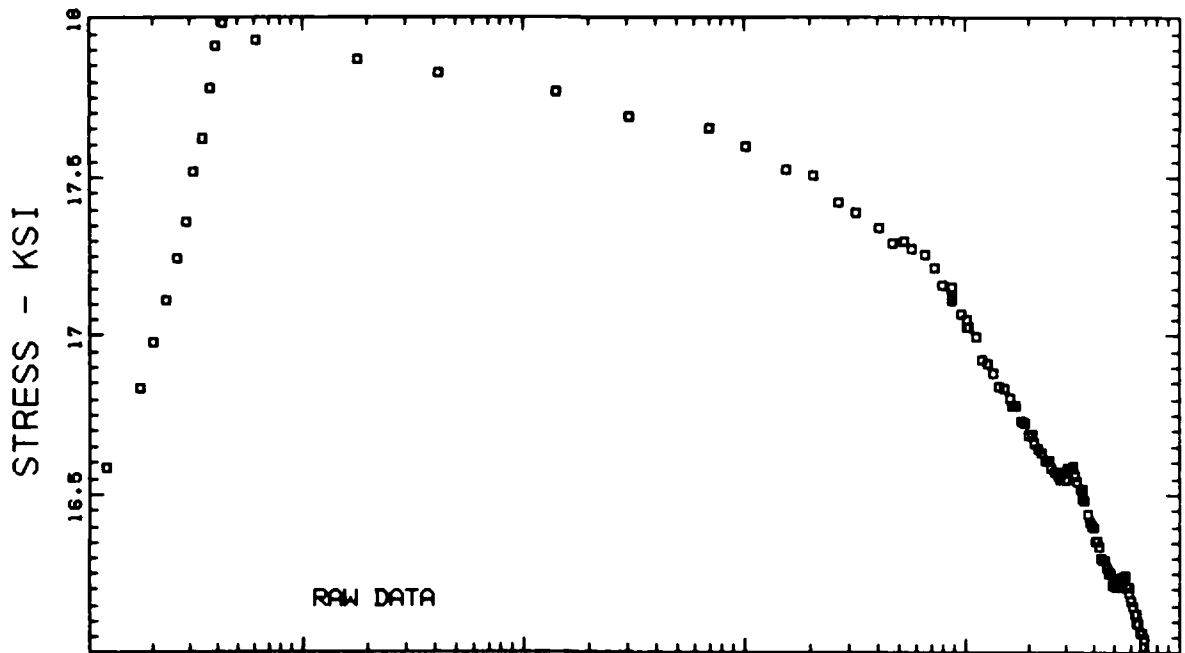

T300/5208 - STEP/RELAXATION - SPECIMEN No. 5 - STEP No. 9

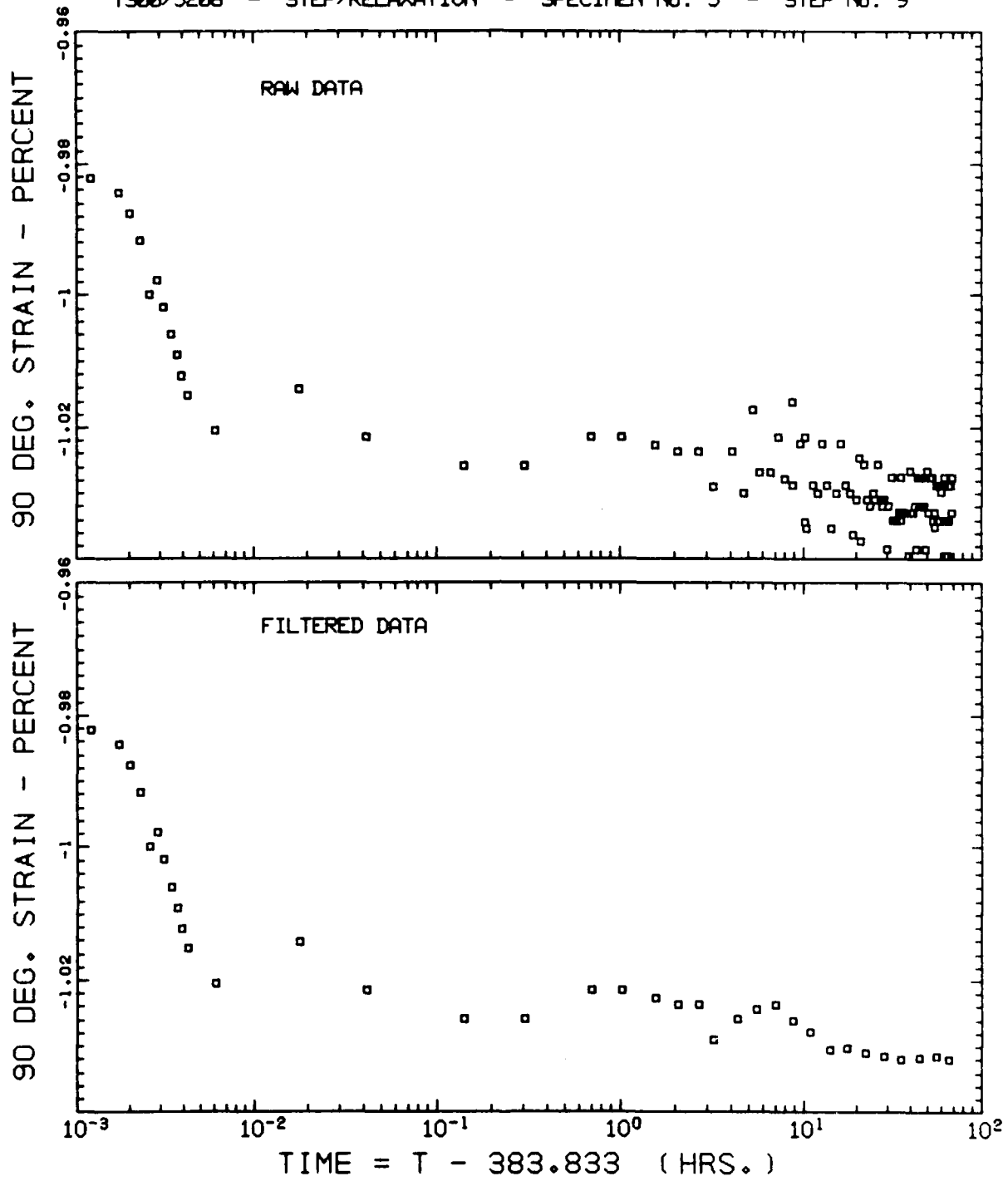

T300/5208 - STEP/RELAXATION - SPECIMEN No. 5 - STEP No. 9

45 DEG. STRAIN - PERCENT

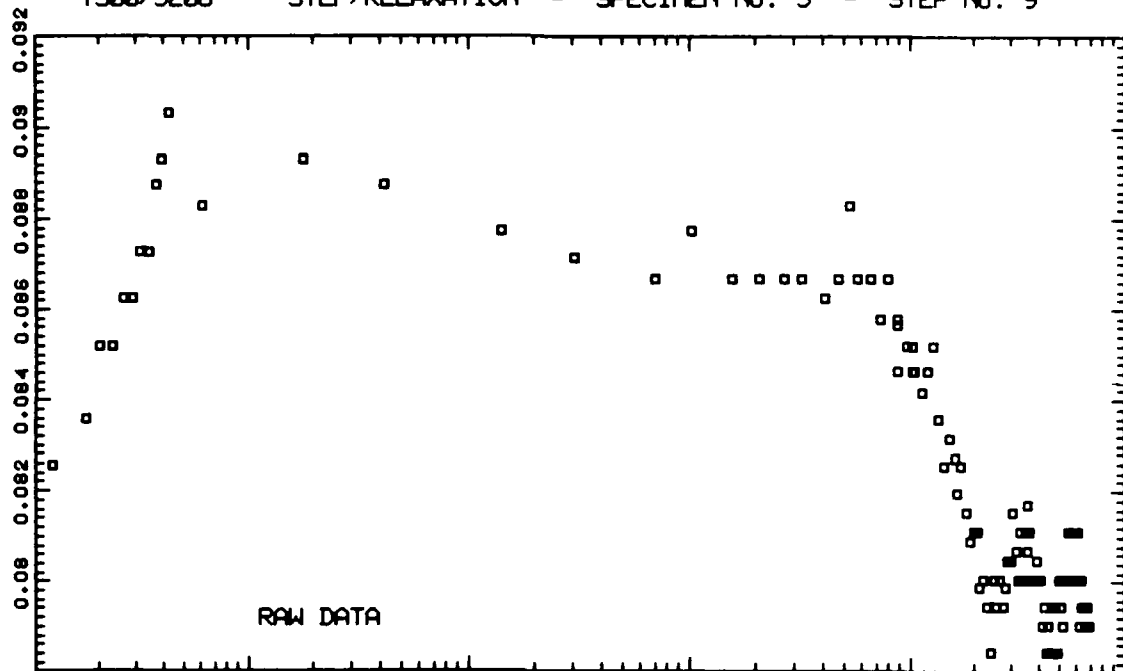

45 DEG. STRAIN - PERCENT

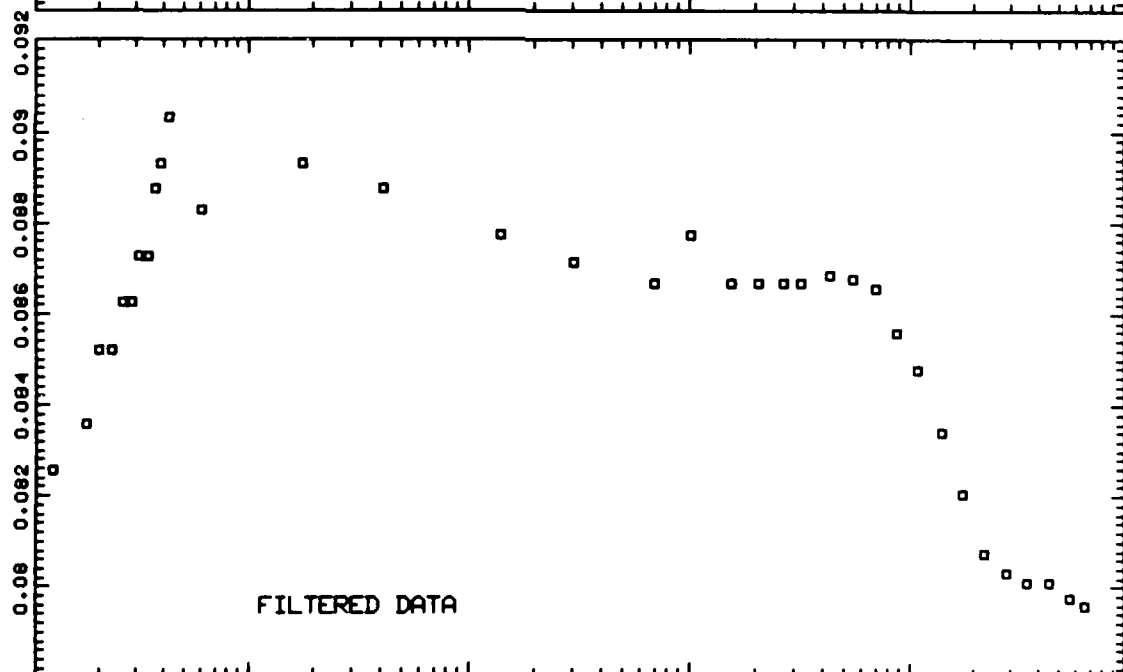

TIME = T - 383.833 (HRS.)

T300/5208 - STEP/RELAXATION - SPECIMEN No. 5 - STEP No. 10

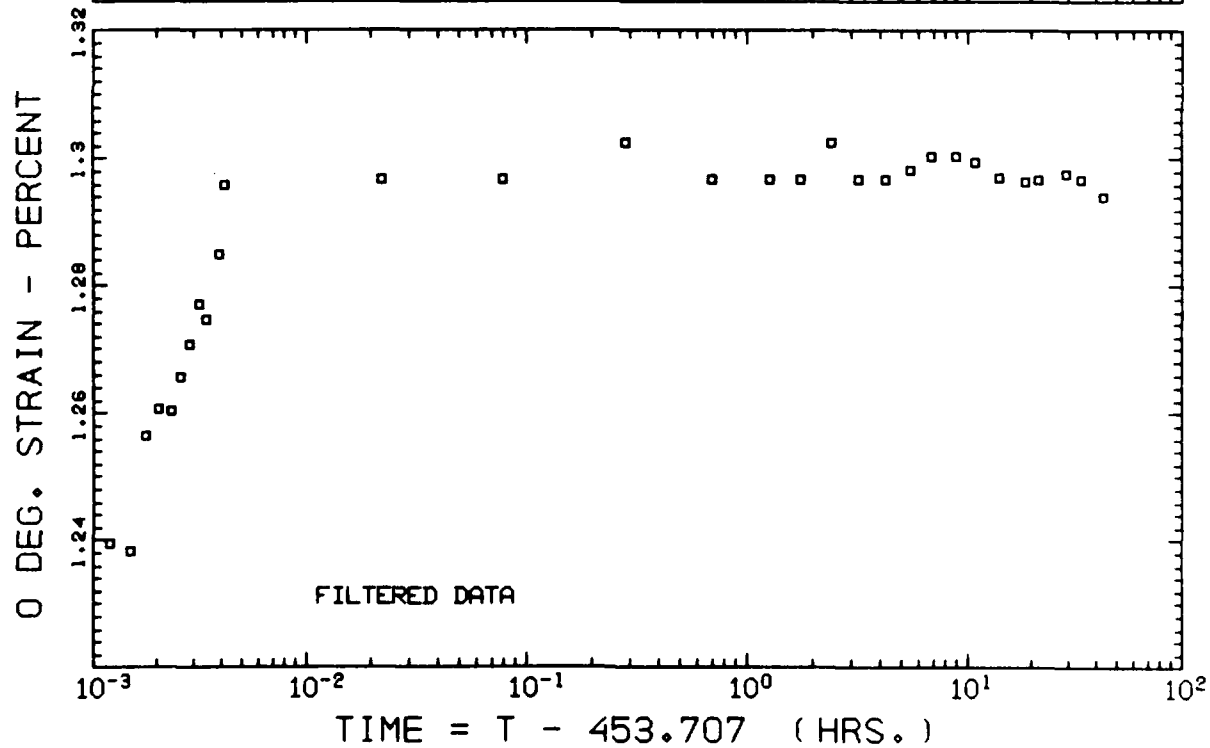
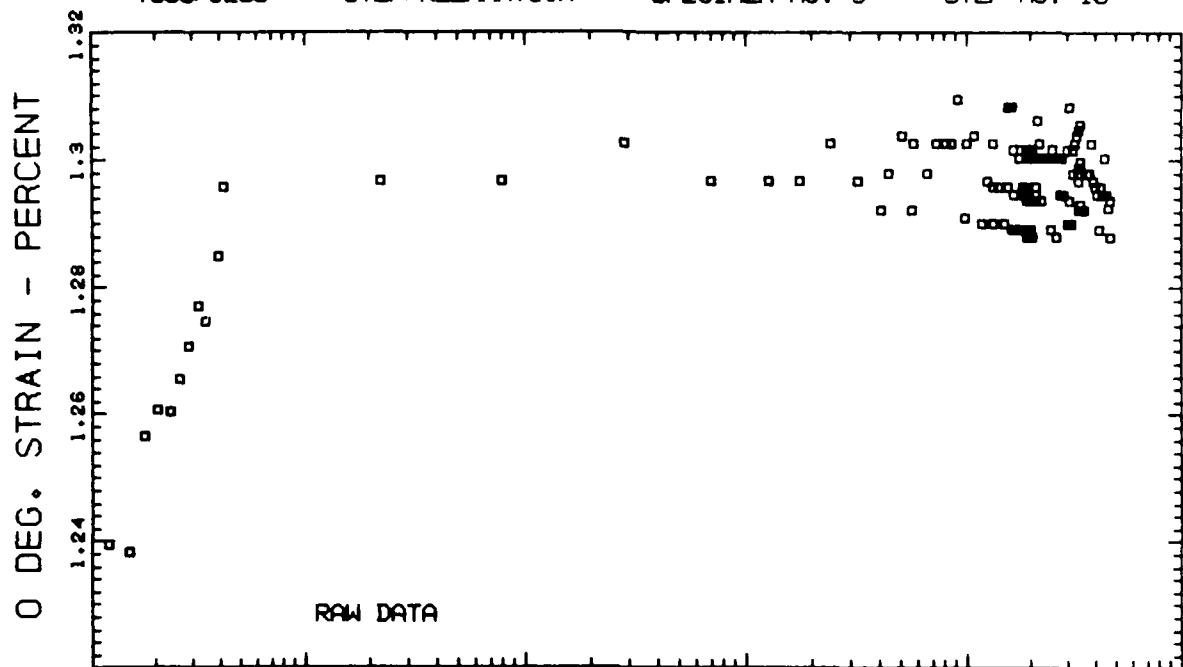



T300/5208 - STEP/RELAXATION - SPECIMEN No. 5 - STEP No. 10

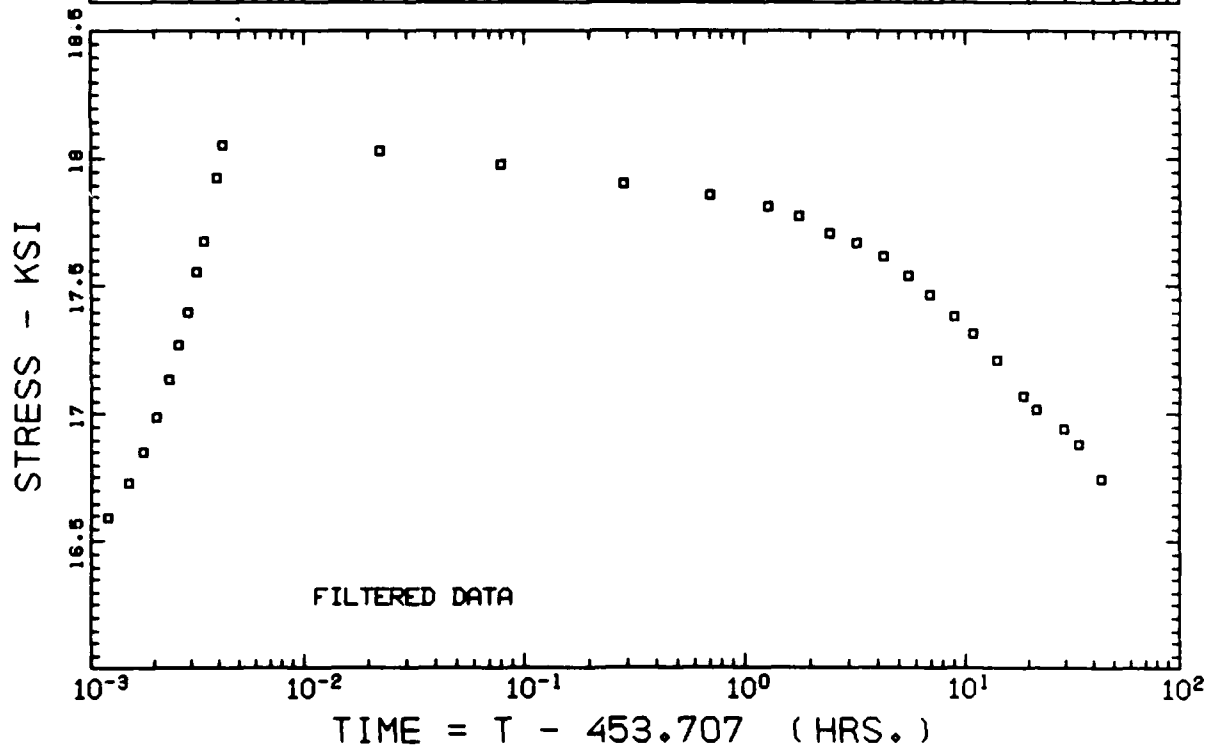
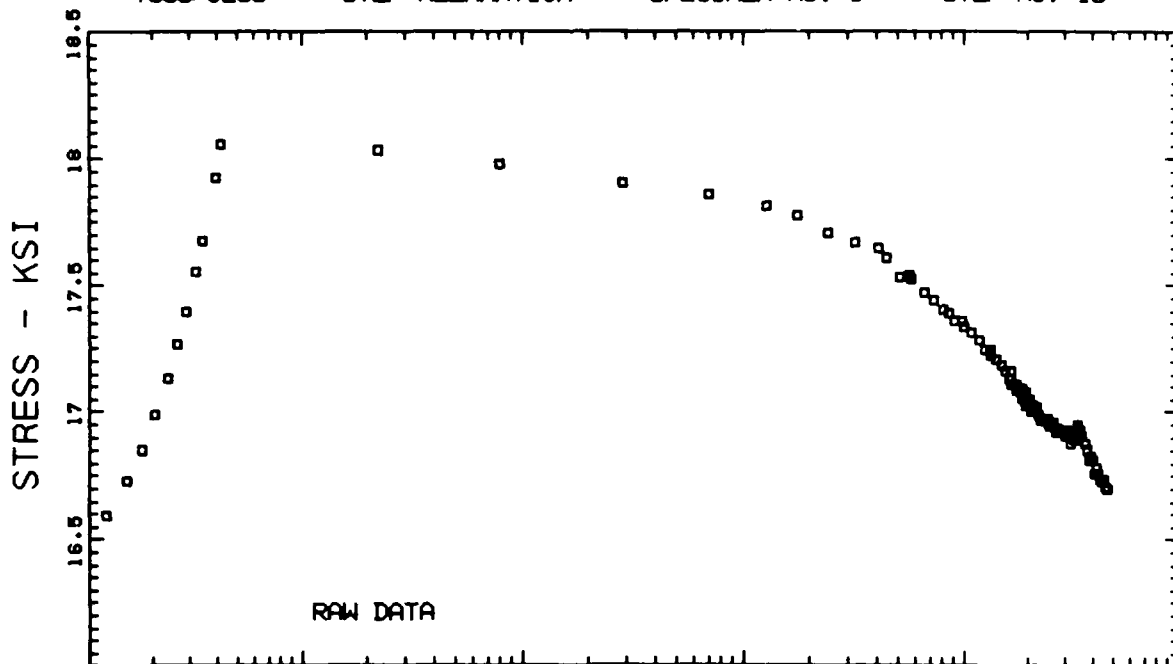

T300/S208 - STEP/RELAXATION - SPECIMEN No. 5 - STEP No. 10

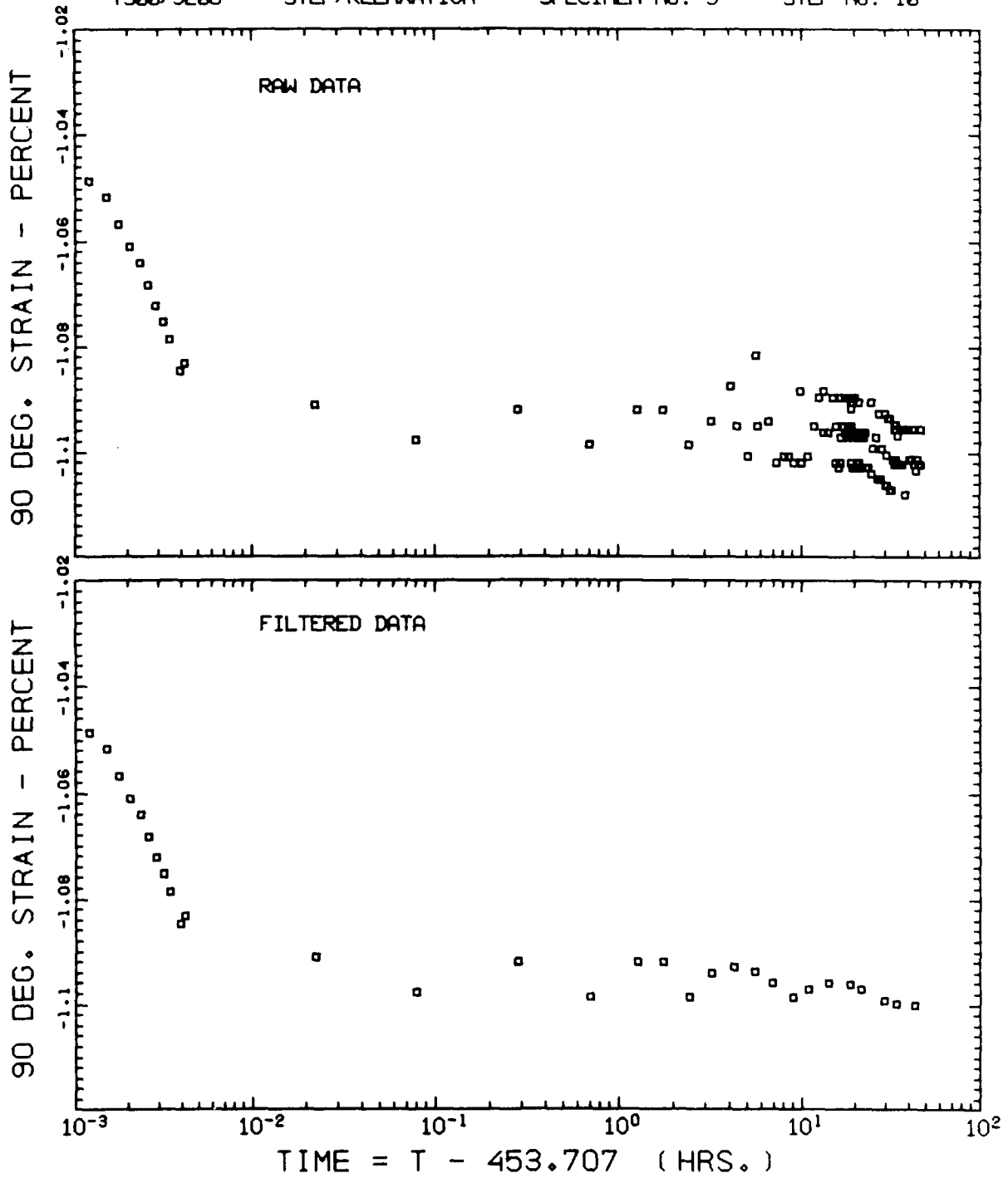

T300/5208 - STEP/RELAXATION - SPECIMEN No. 5 - STEP No. 10

45 DEG. STRAIN - PERCENT

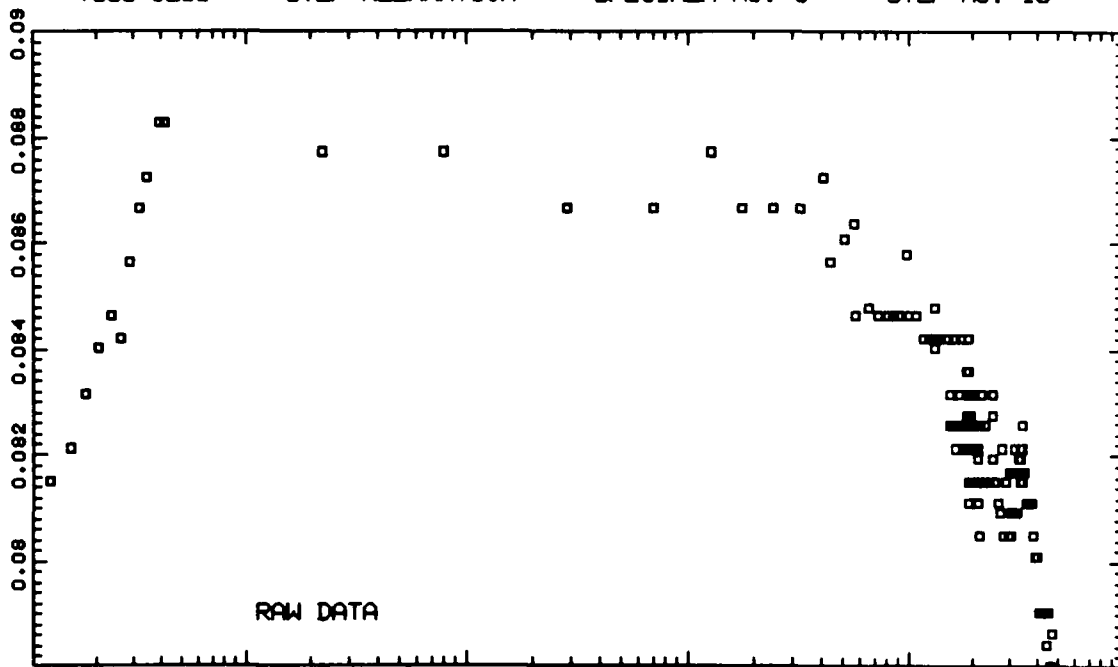

45 DEG. STRAIN - PERCENT

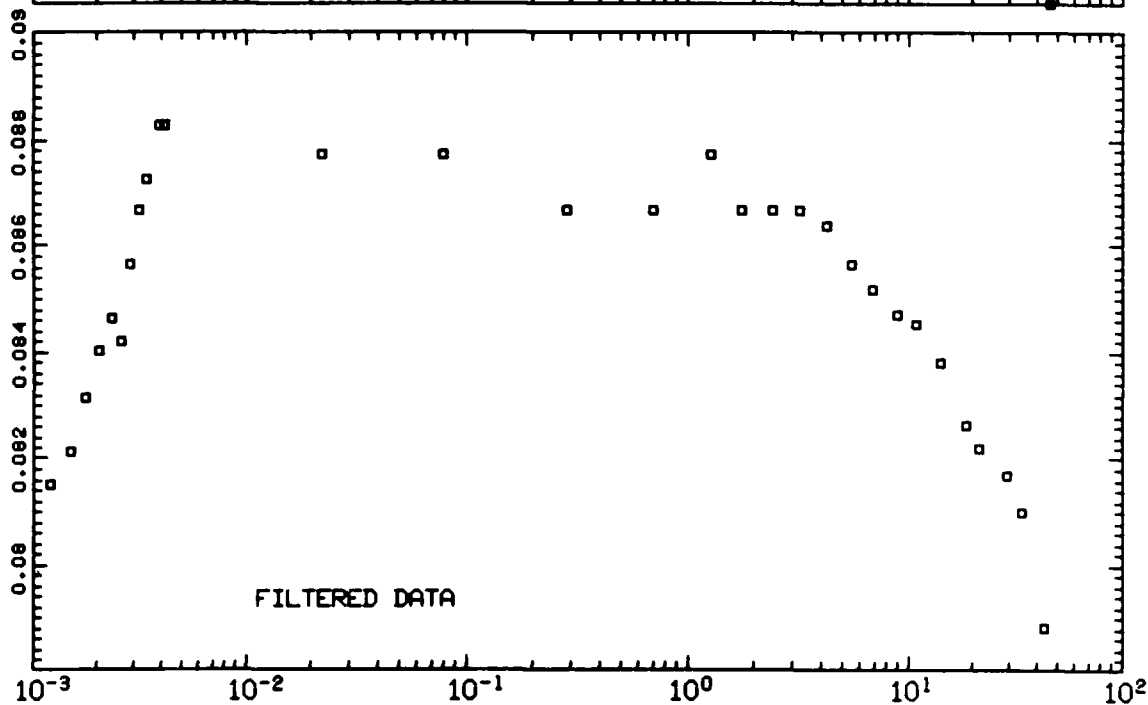

TIME = T - 453.707 (HRS.)

T300/5208 - STEP/RELAXATION - SPECIMEN No. 5 - STEP No. 11

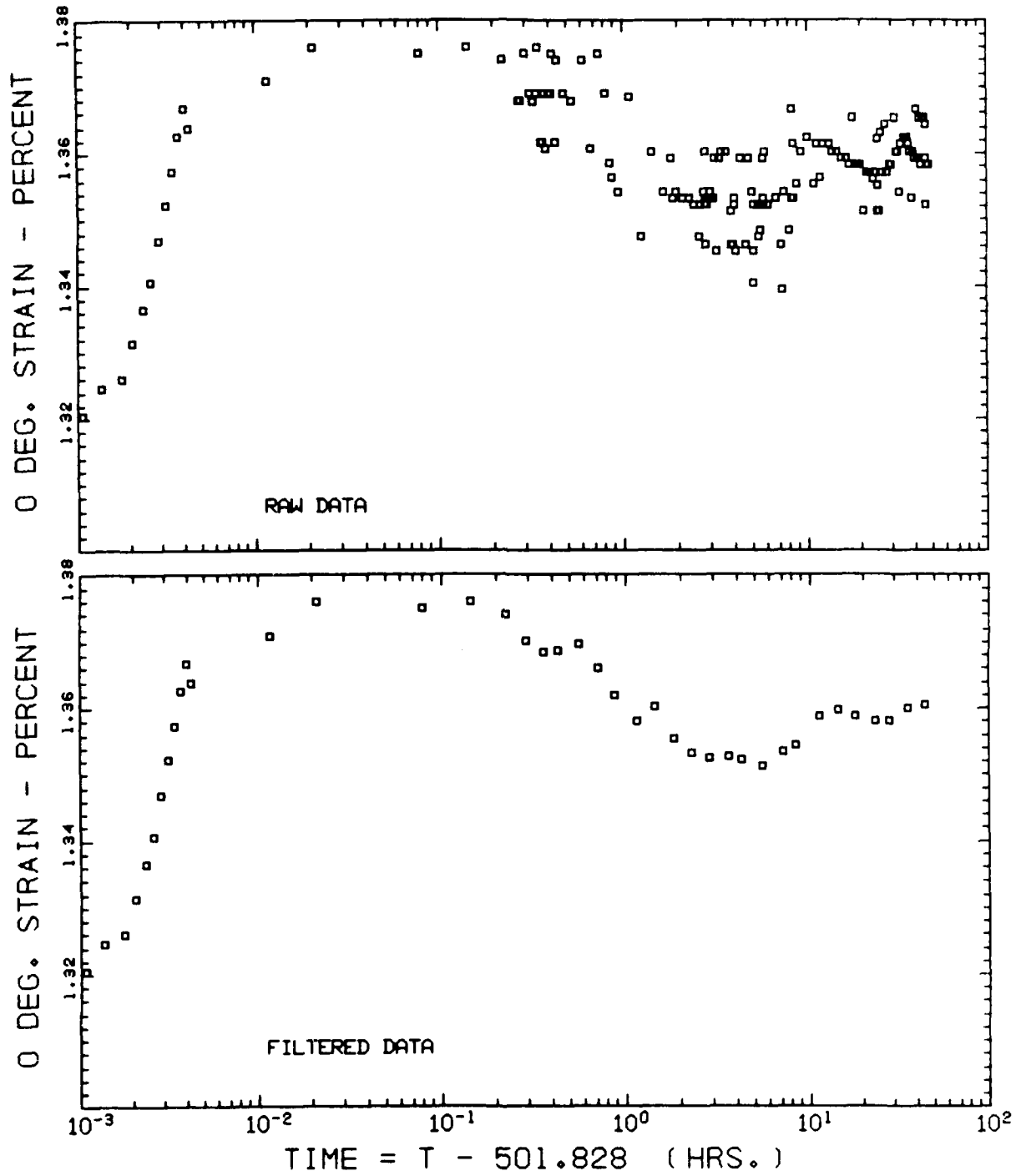

T300/5208 - STEP/RELAXATION - SPECIMEN No. 5 - STEP No. 11

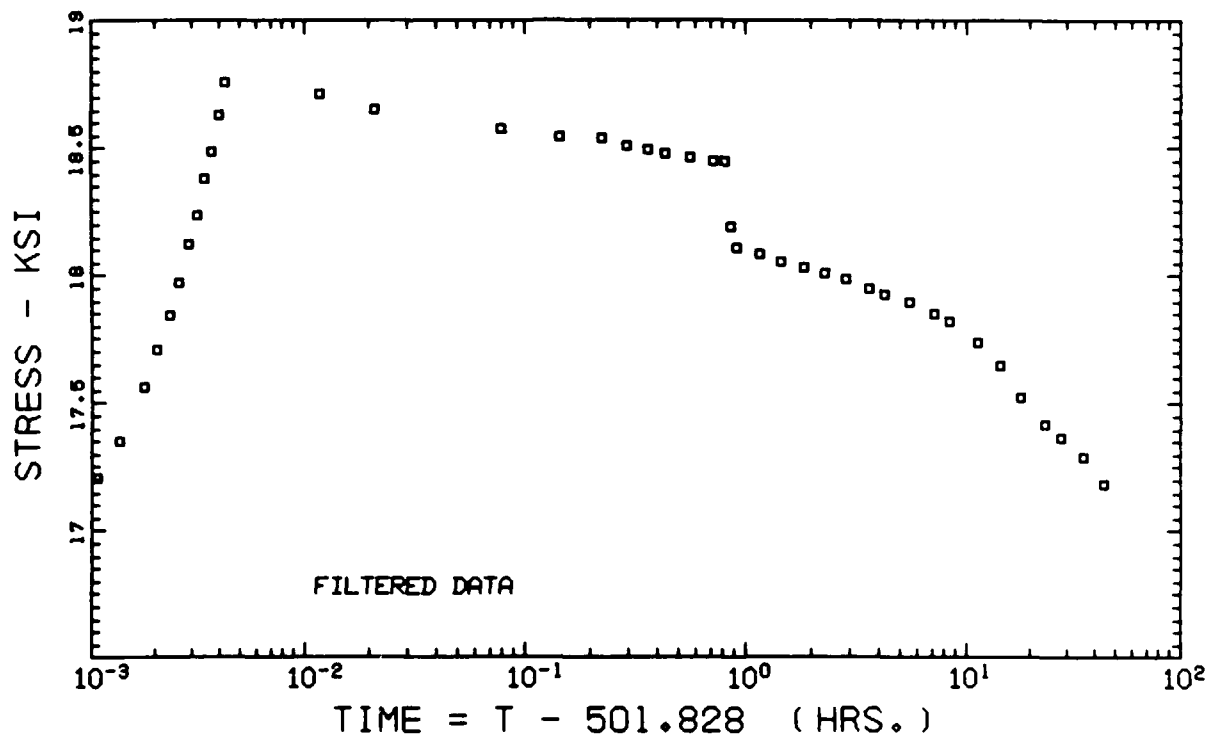
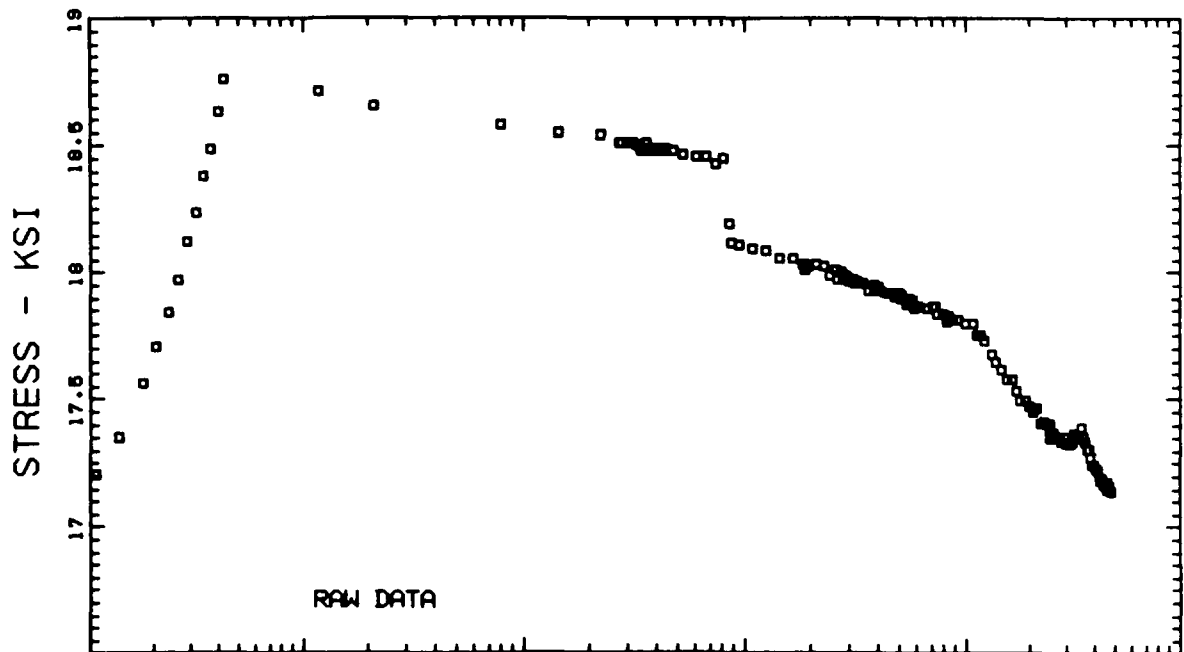

T300/5208 - STEP/RELAXATION - SPECIMEN No. 5 - STEP No. 11

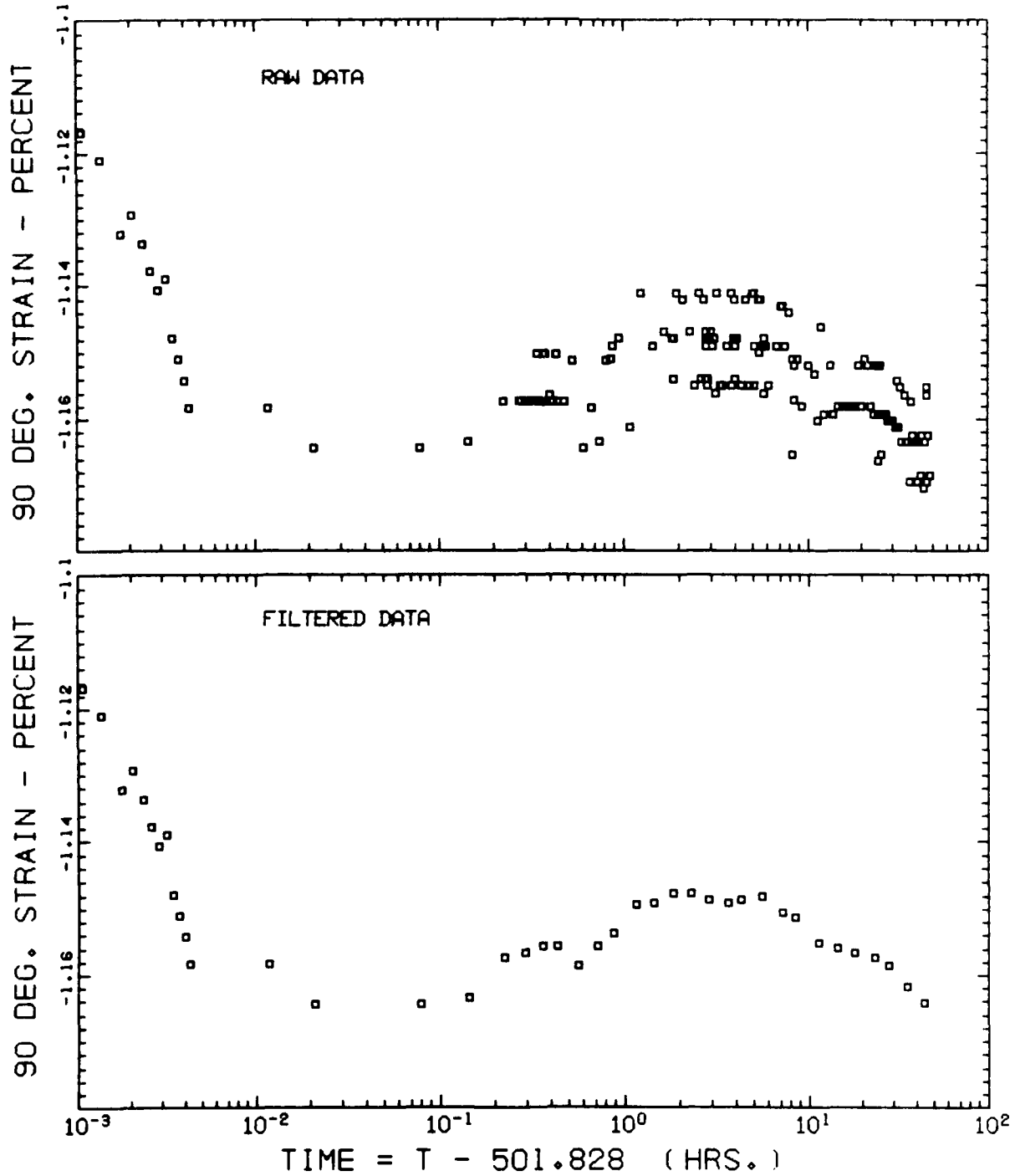

T300/5208 - STEP/RELAXATION - SPECIMEN No. 5 - STEP No. 11

45 DEG. STRAIN - PERCENT

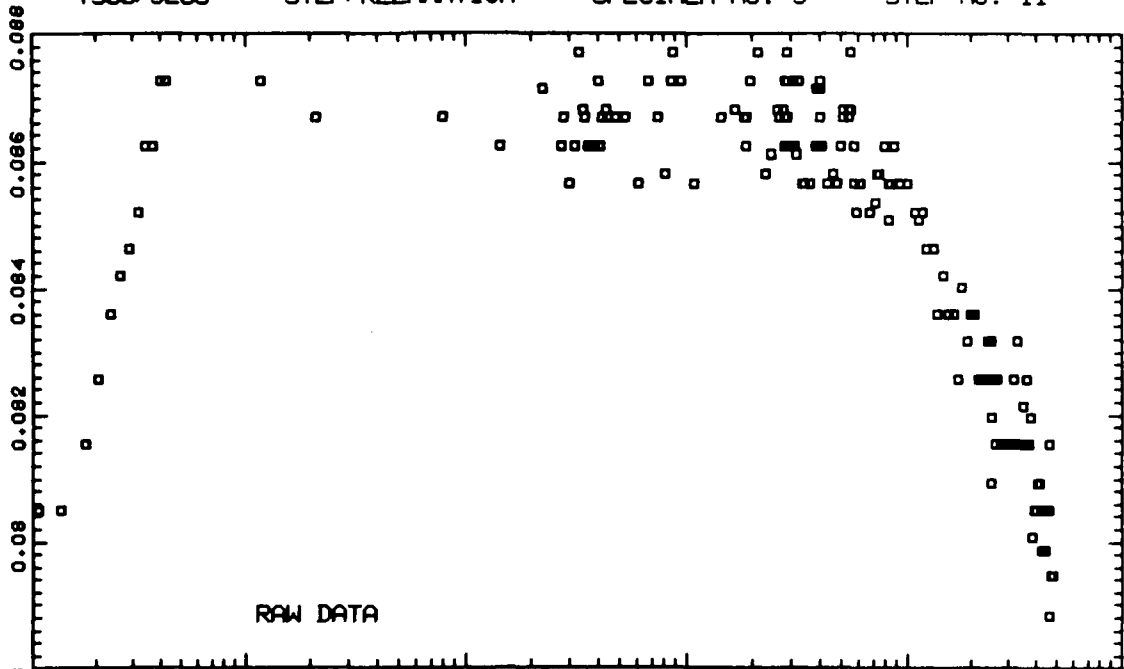

45 DEG. STRAIN - PERCENT

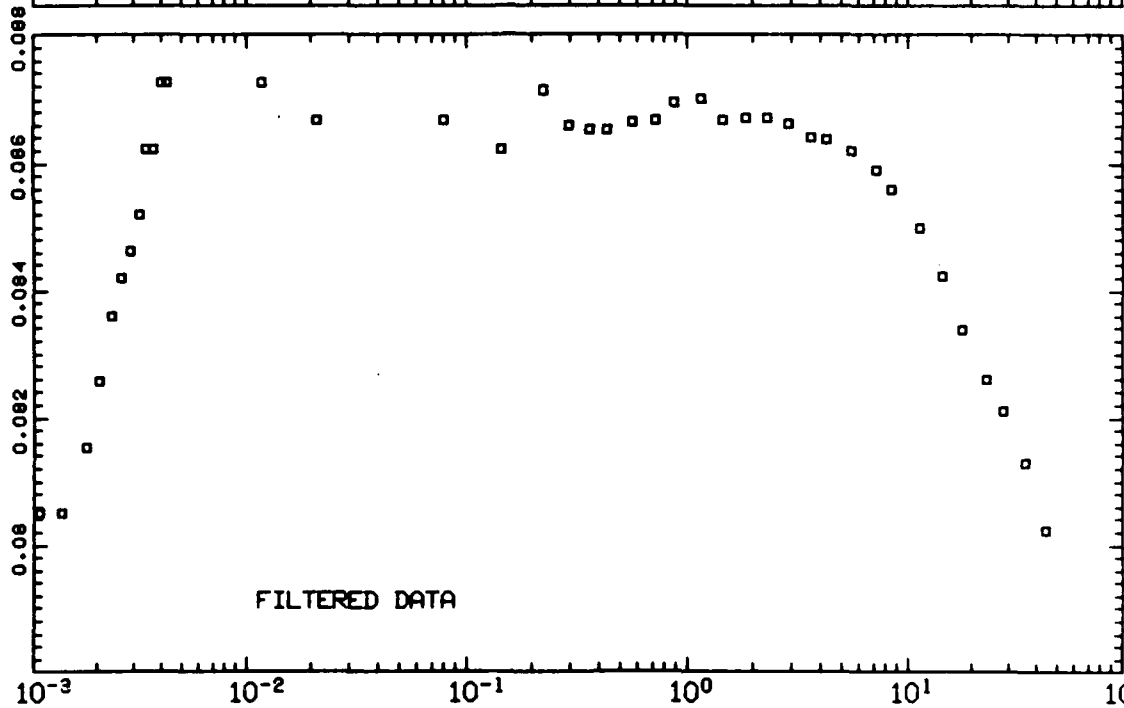

TIME = T - 501.828 (HRS.)

T300/5208 - STEP/RELAXATION - SPECIMEN No. 5 - STEP No. 12

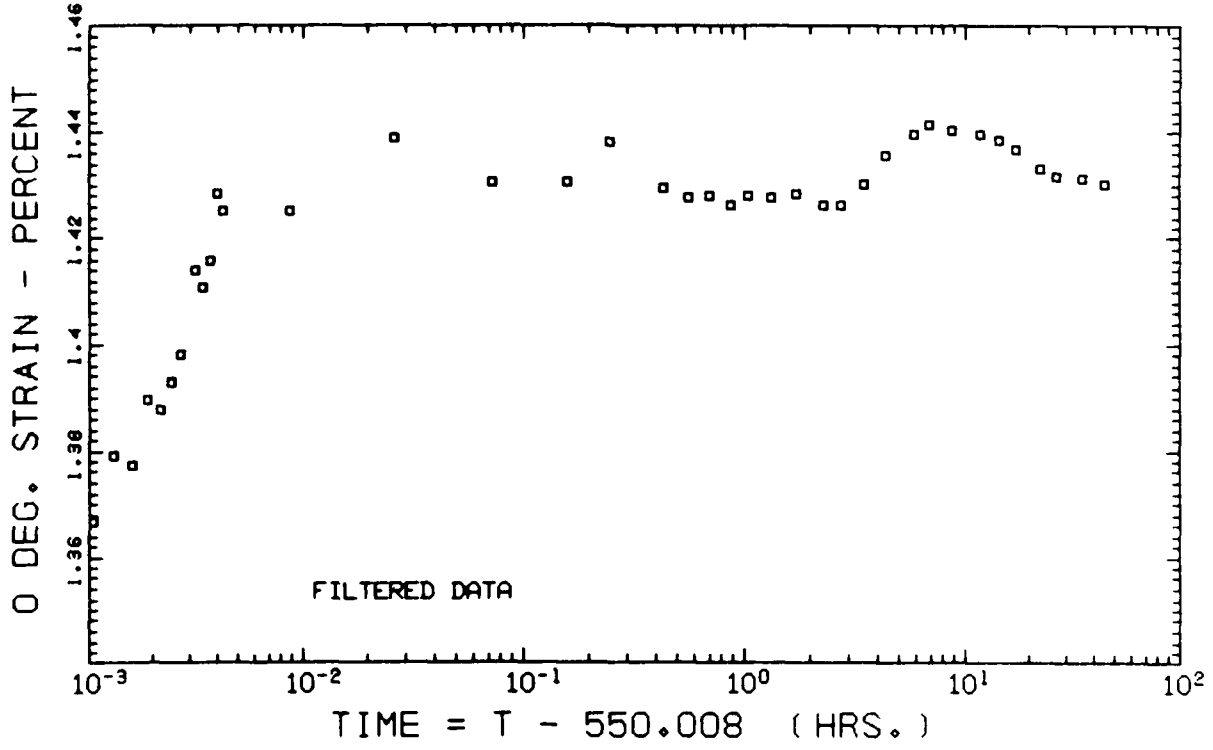
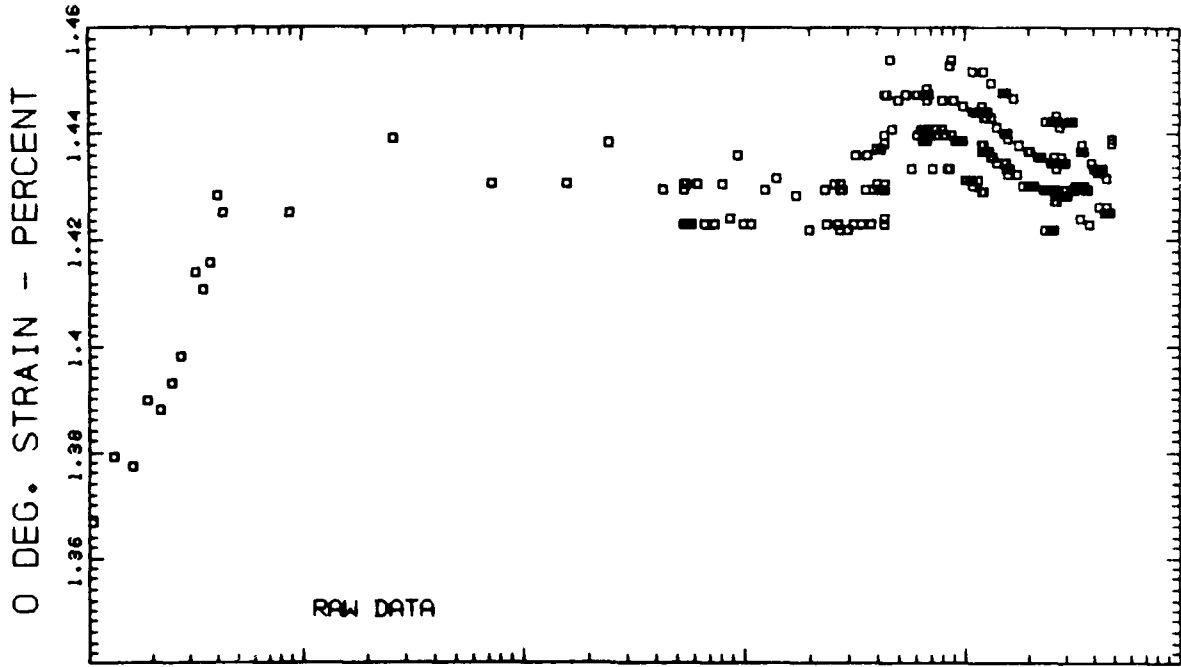



T300/S208 - STEP/RELAXATION - SPECIMEN No. 5 - STEP No. 12

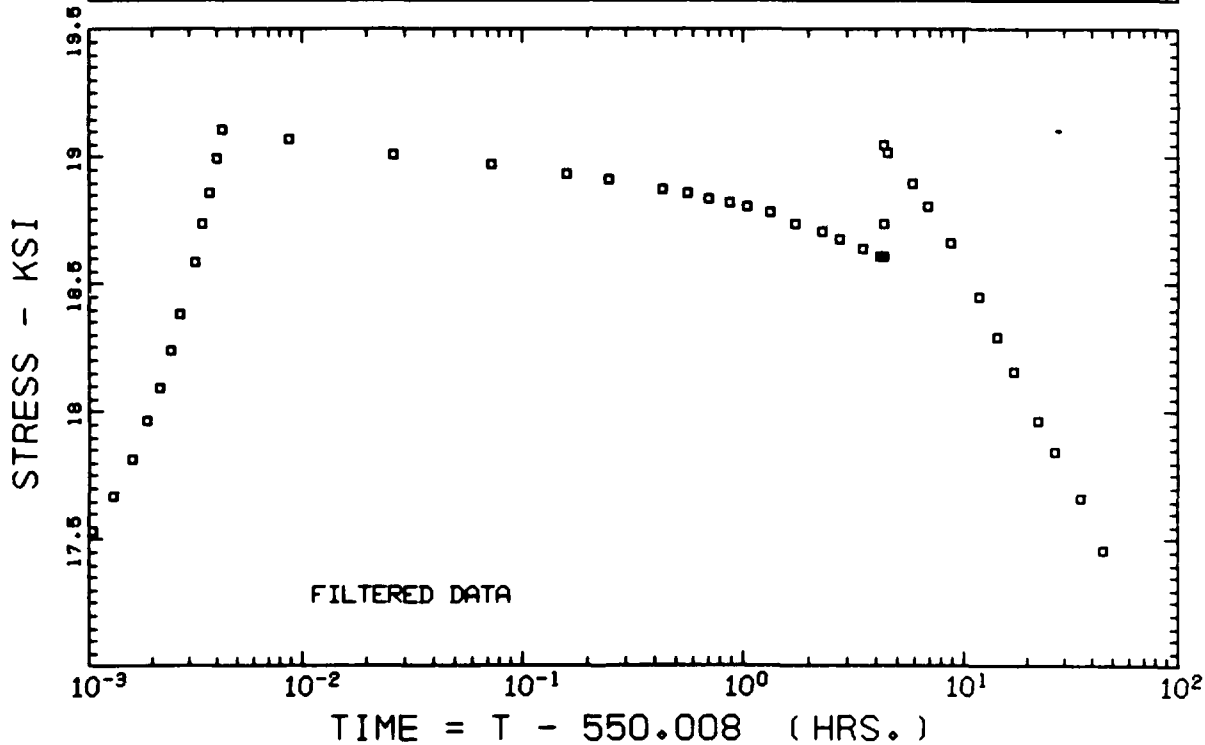
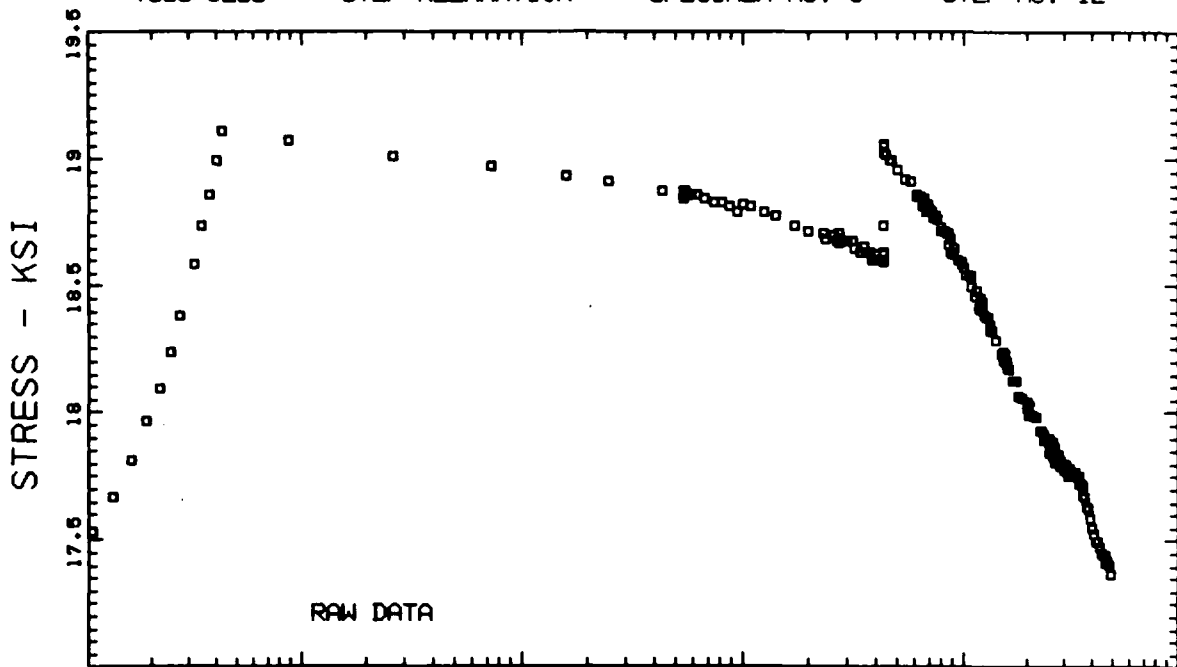

T300/5208 - STEP/RELAXATION - SPECIMEN No. 5 - STEP No. 12

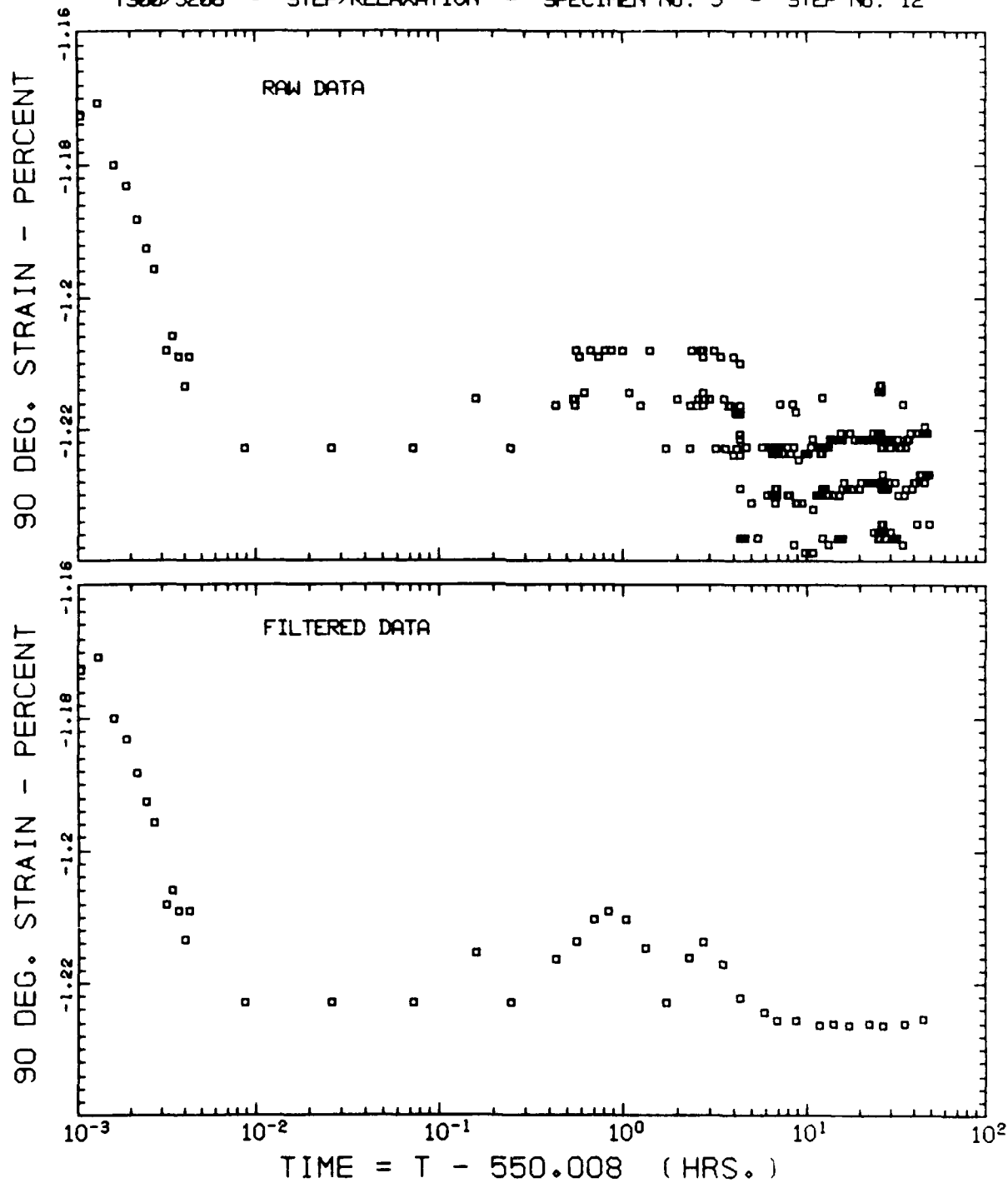

T300/S208 - STEP/RELAXATION - SPECIMEN No. 5 - STEP No. 12

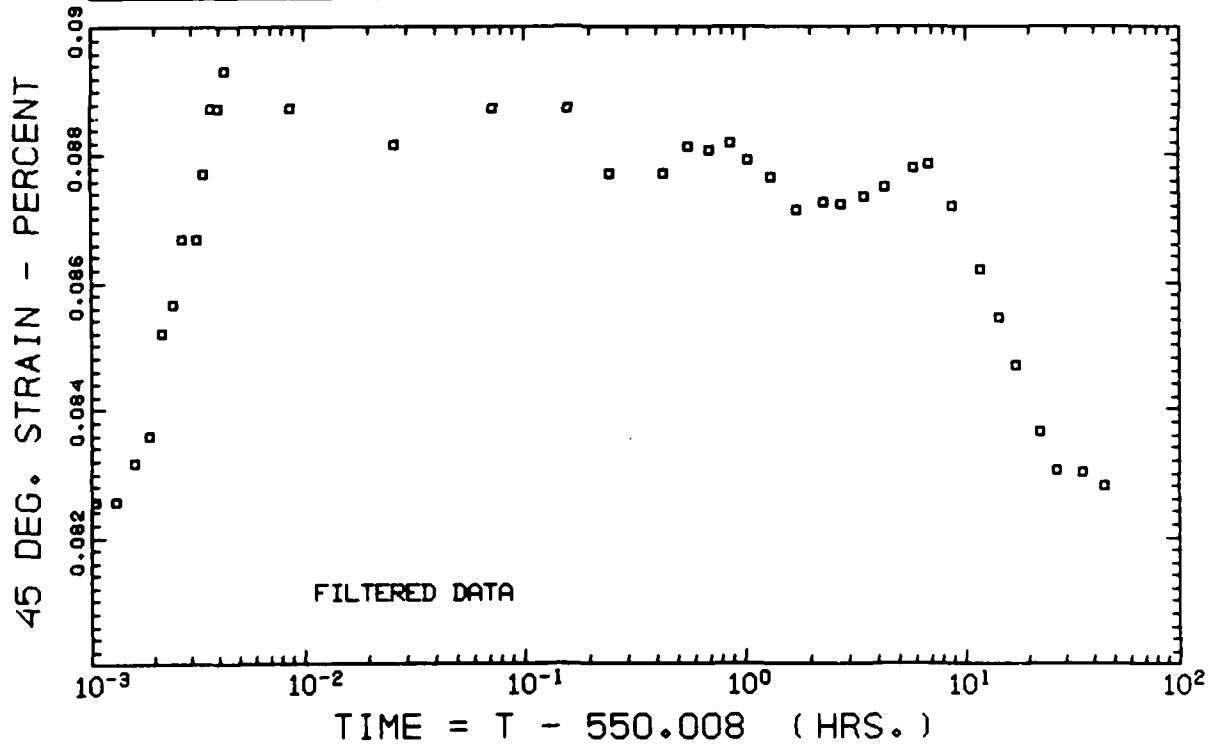
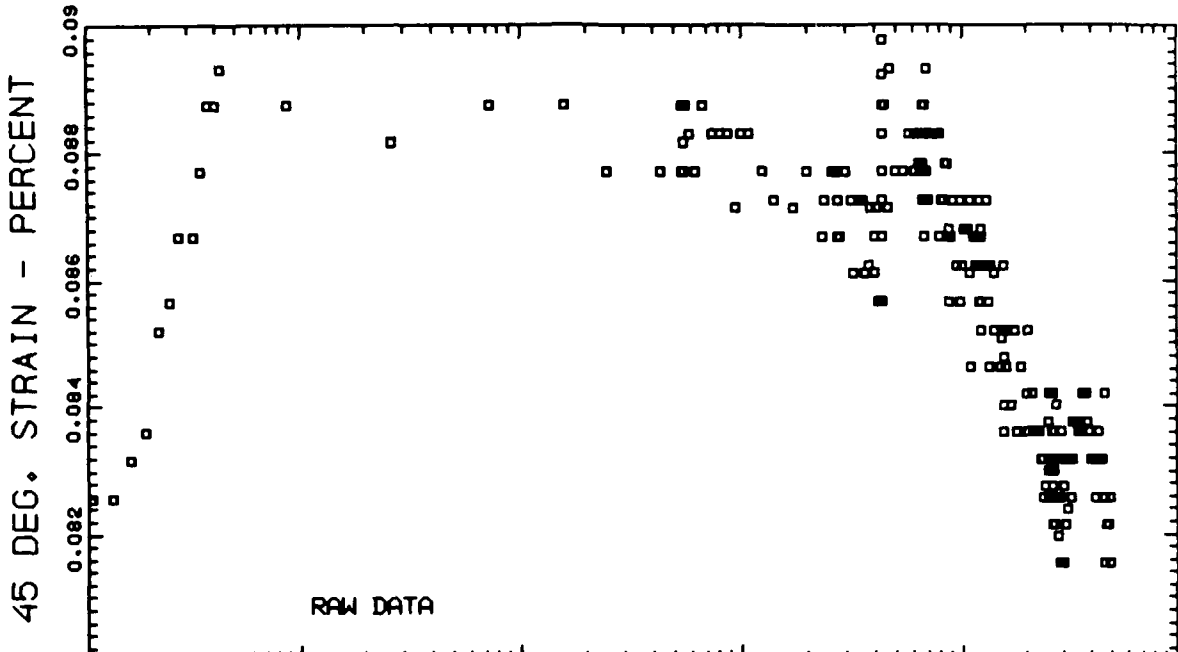

T300/5208 - STEP/RELAXATION - SPECIMEN NO. 6

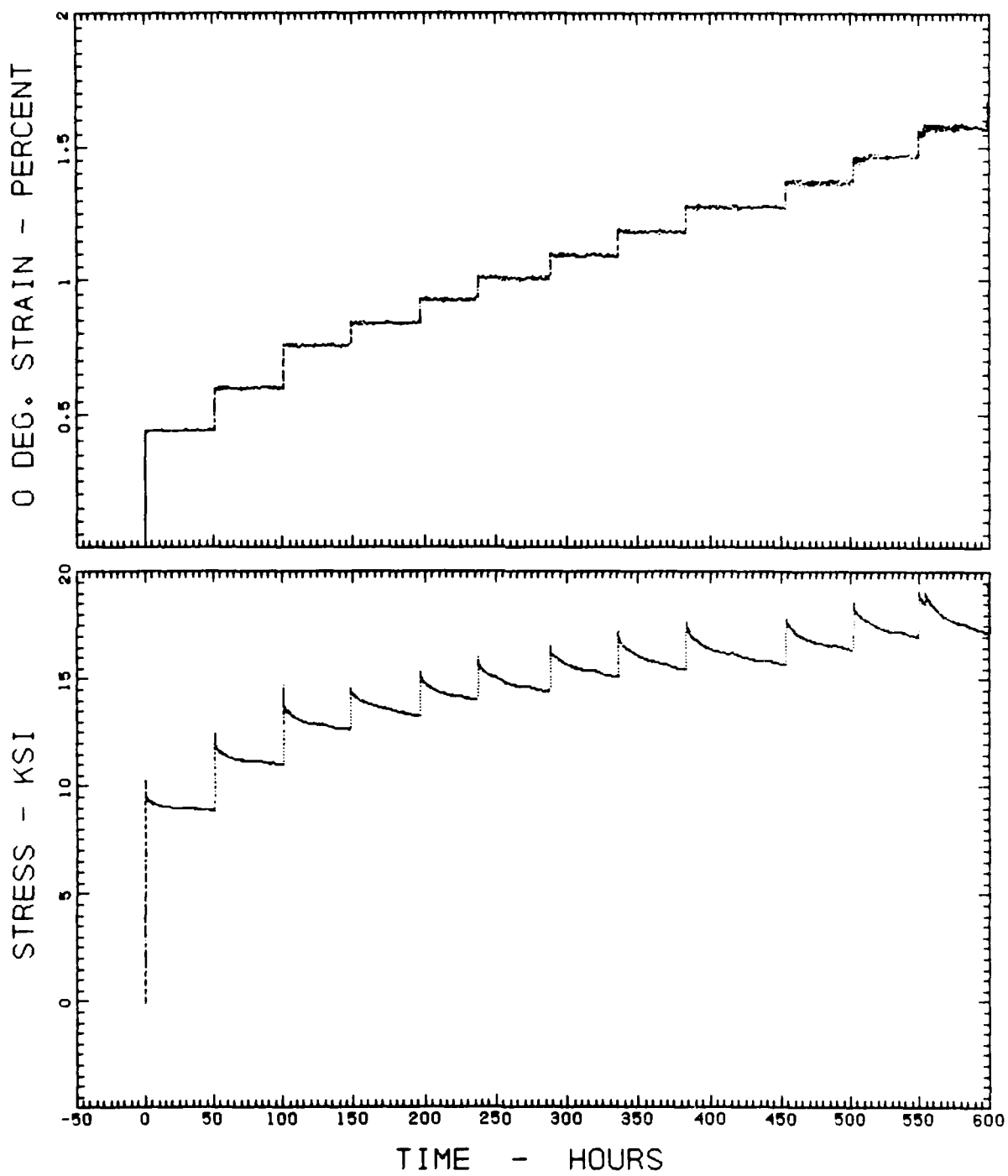

T300/5208 - STEP/RELAXATION - SPECIMEN NO. 6

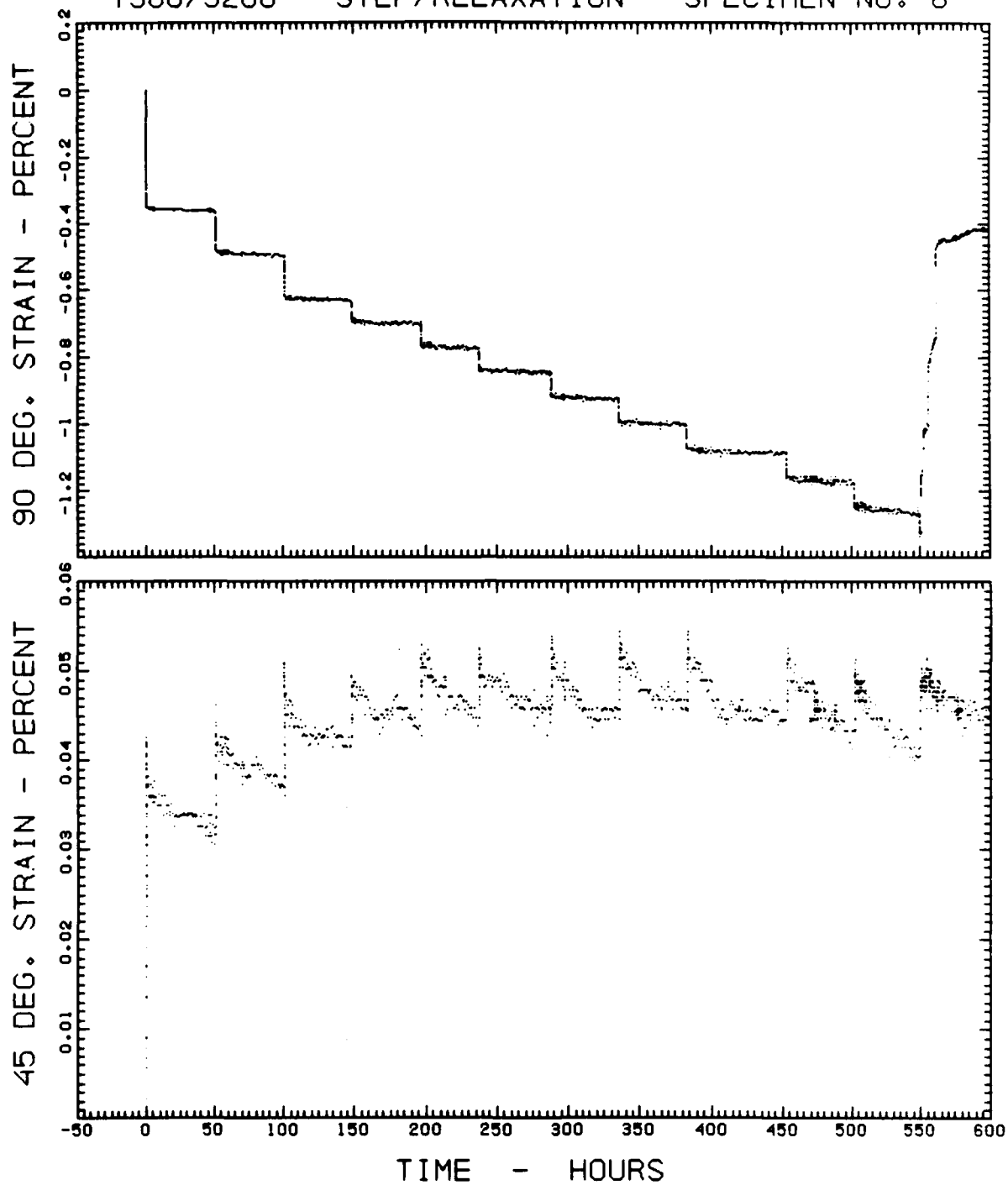

T300/S208 - STEP/RELAXATION - SPECIMEN No. 6 - STEP No. 1

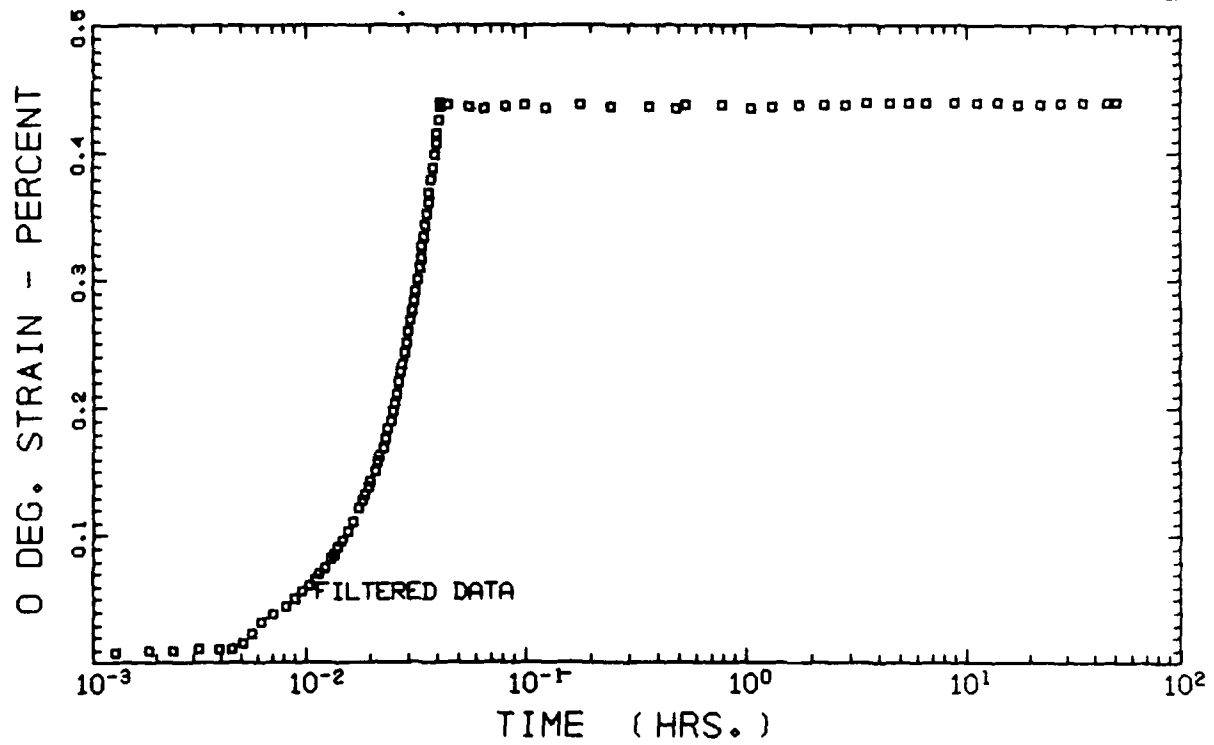
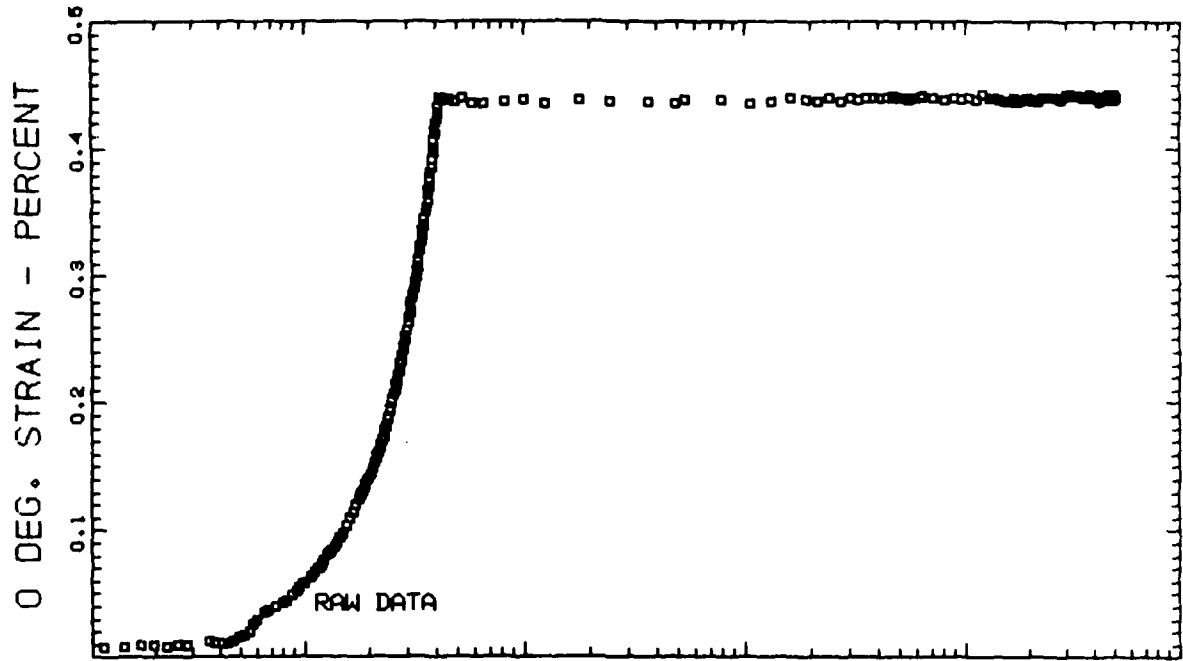

T300/5208 - STEP/RELAXATION - SPECIMEN No. 6 - STEP No. 1

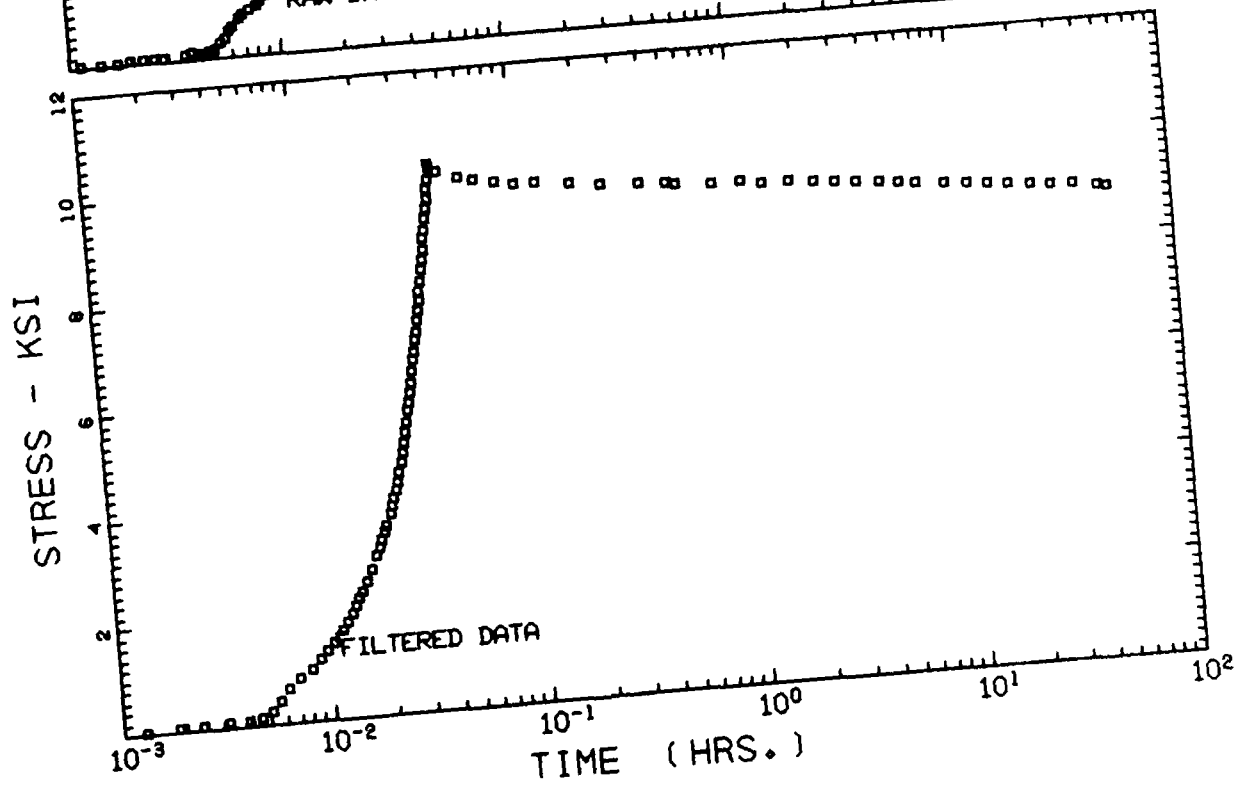
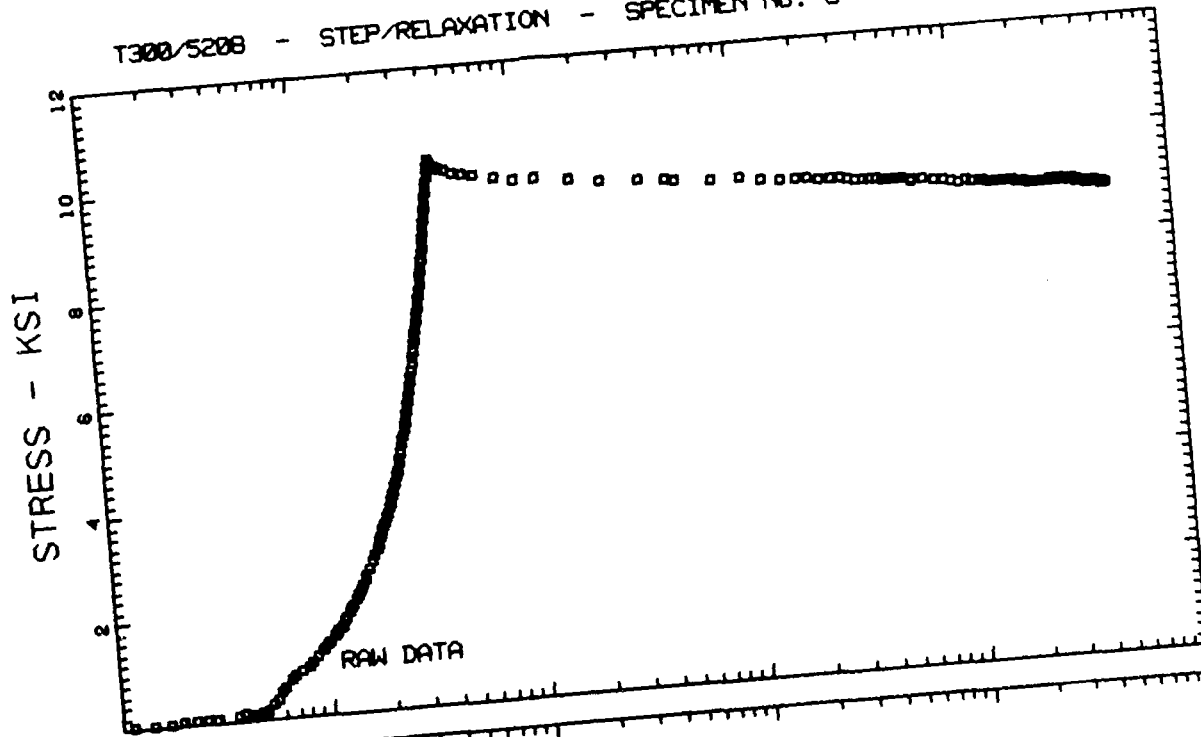

T300/5208 - STEP/RELAXATION - SPECIMEN No. 6 - STEP No. 1

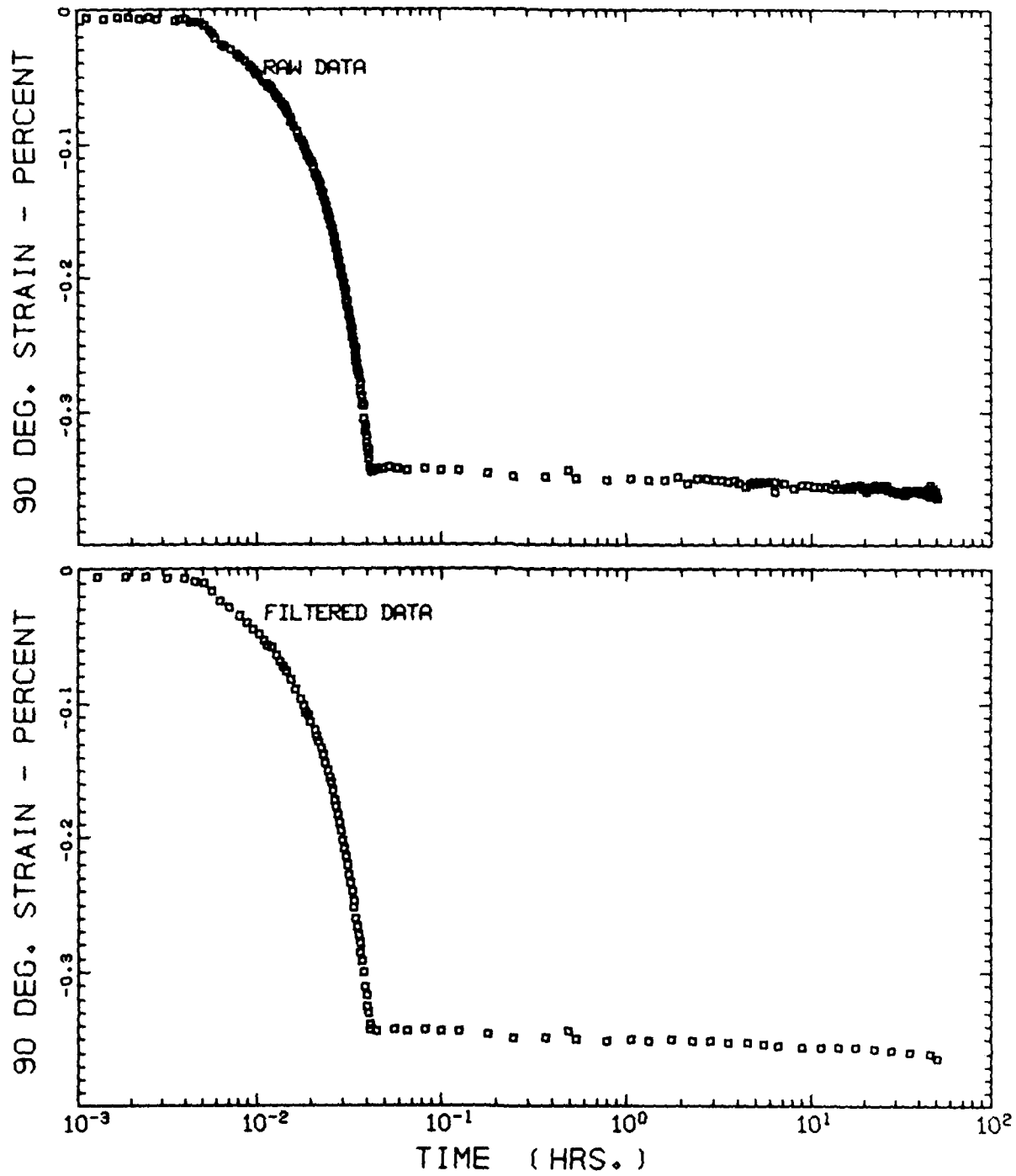



T300/5208 - STEP/RELAXATION - SPECIMEN No. 6 - STEP No. 1

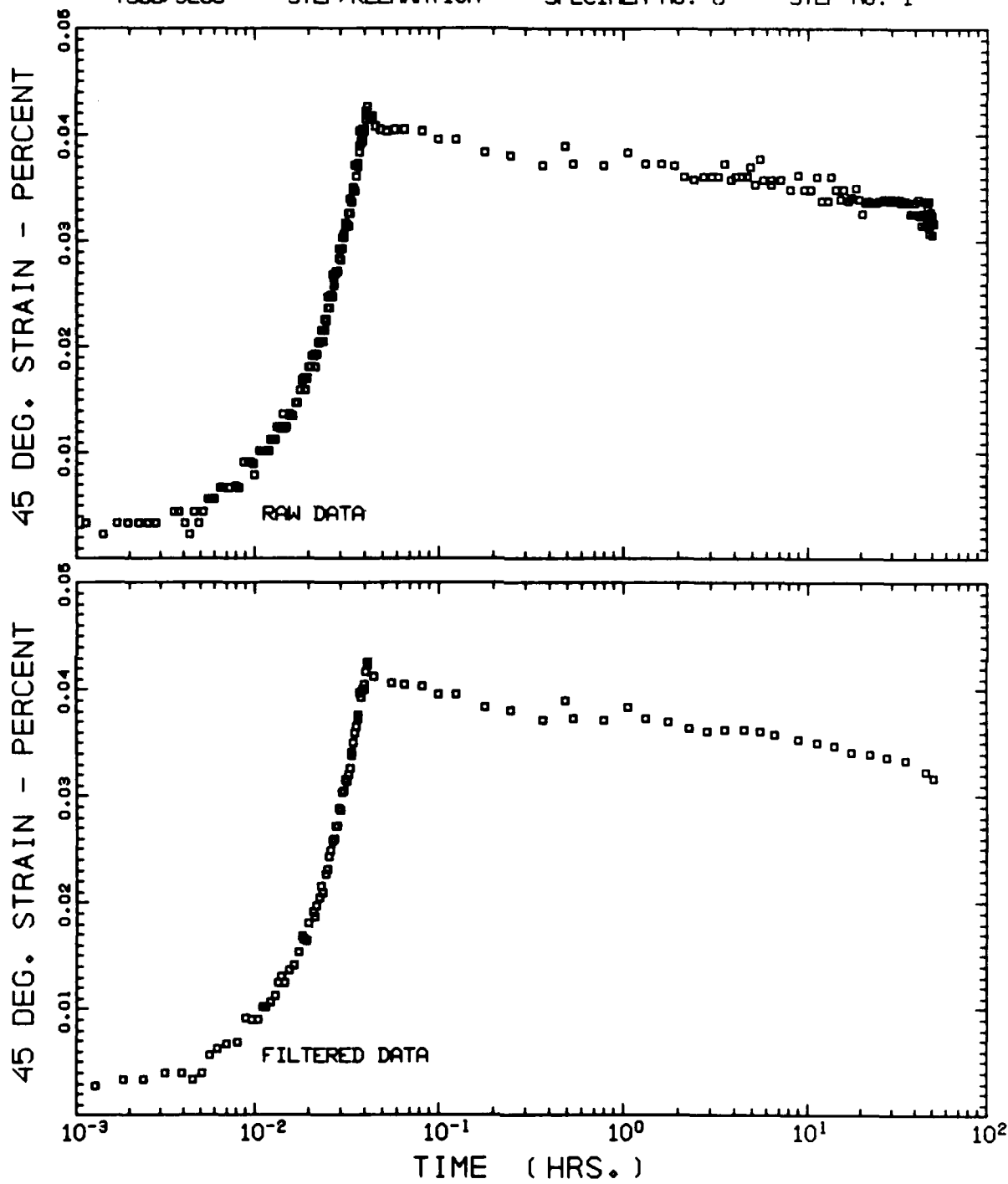

T300/5208 - STEP/RELAXATION - SPECIMEN No. 6 - STEP No. 2

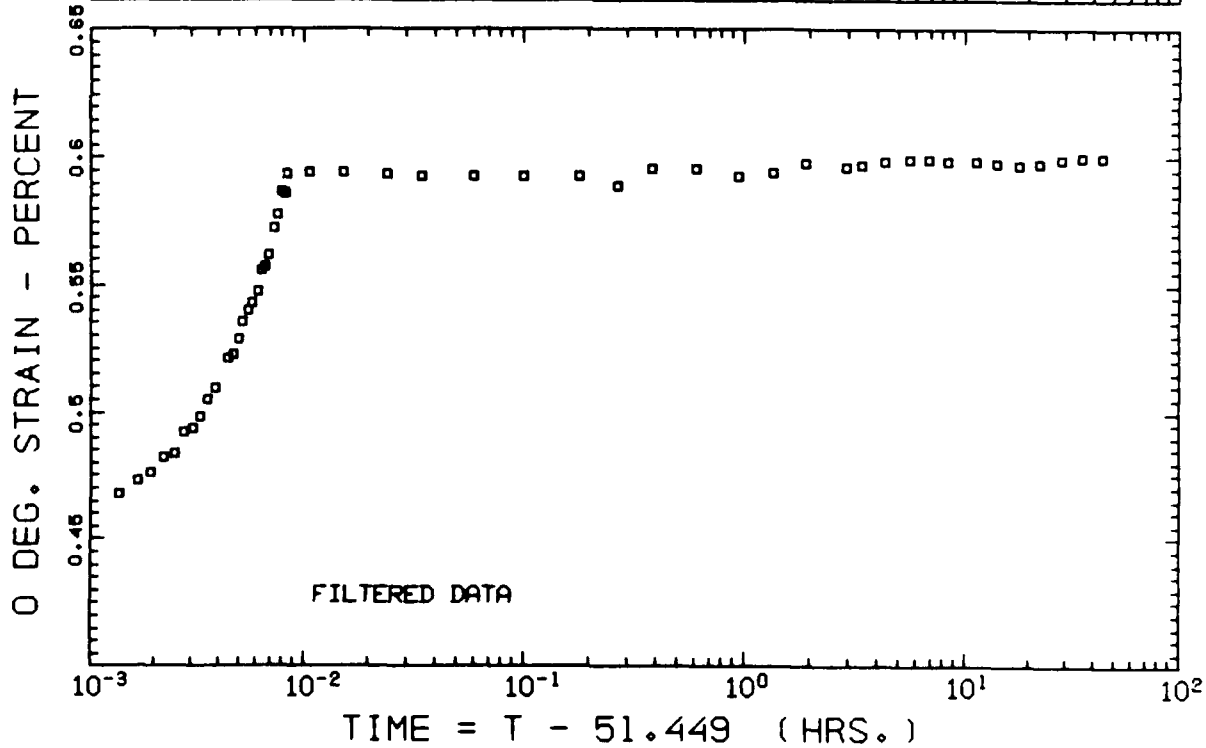
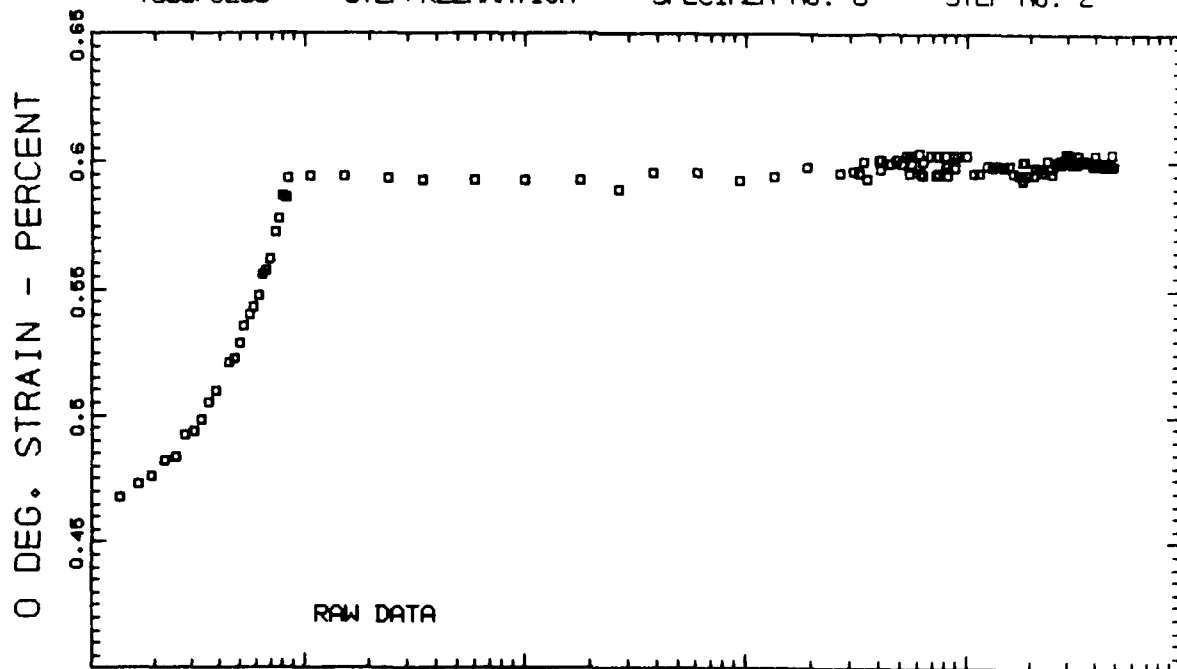

T300/5208 - STEP/RELAXATION -- SPECIMEN No. 6 - STEP No. 2

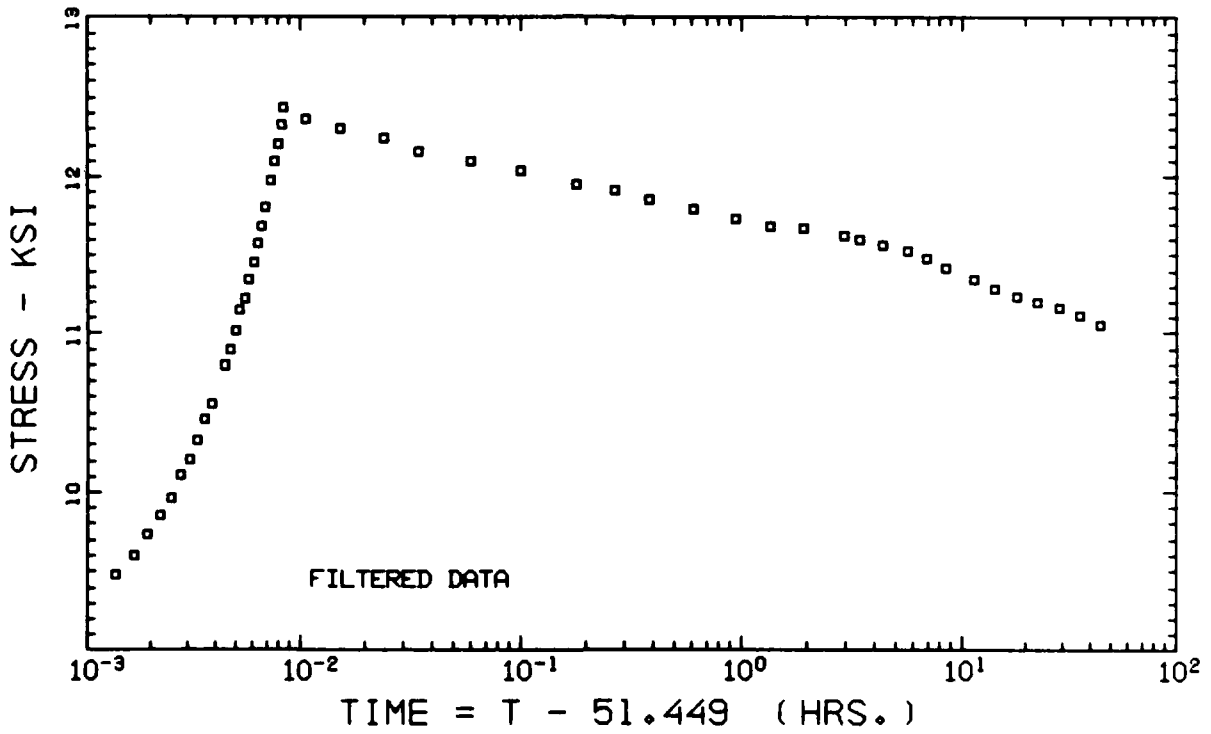
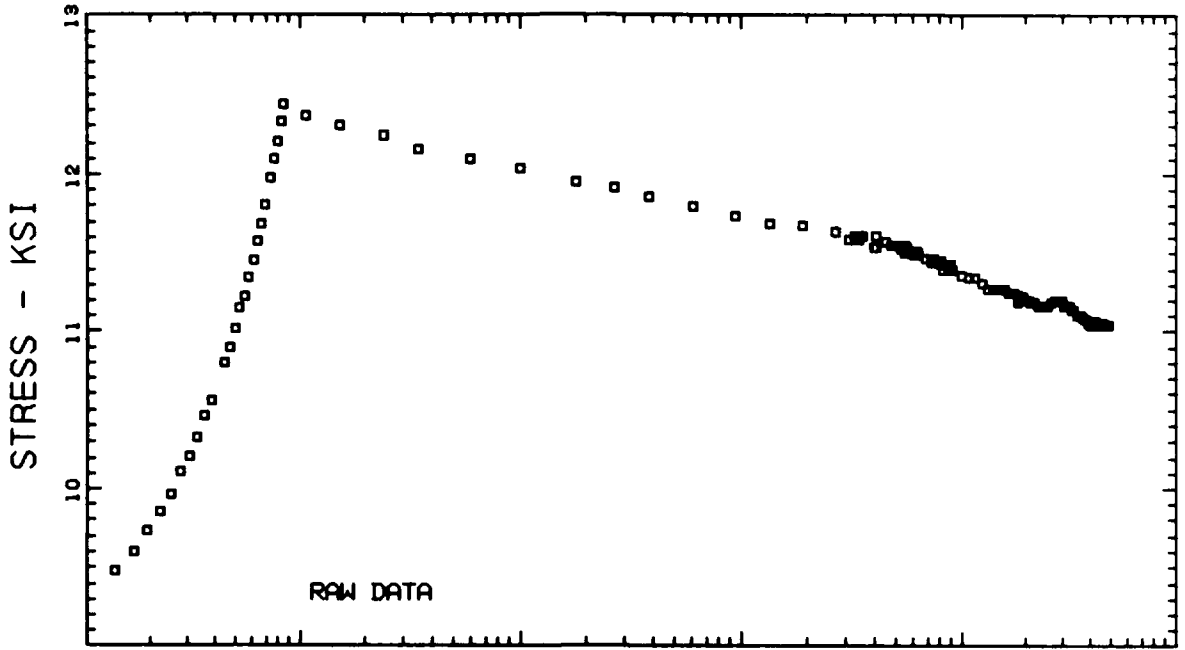

T300/5208 - STEP/RELAXATION - SPECIMEN No. 6 - STEP No. 2

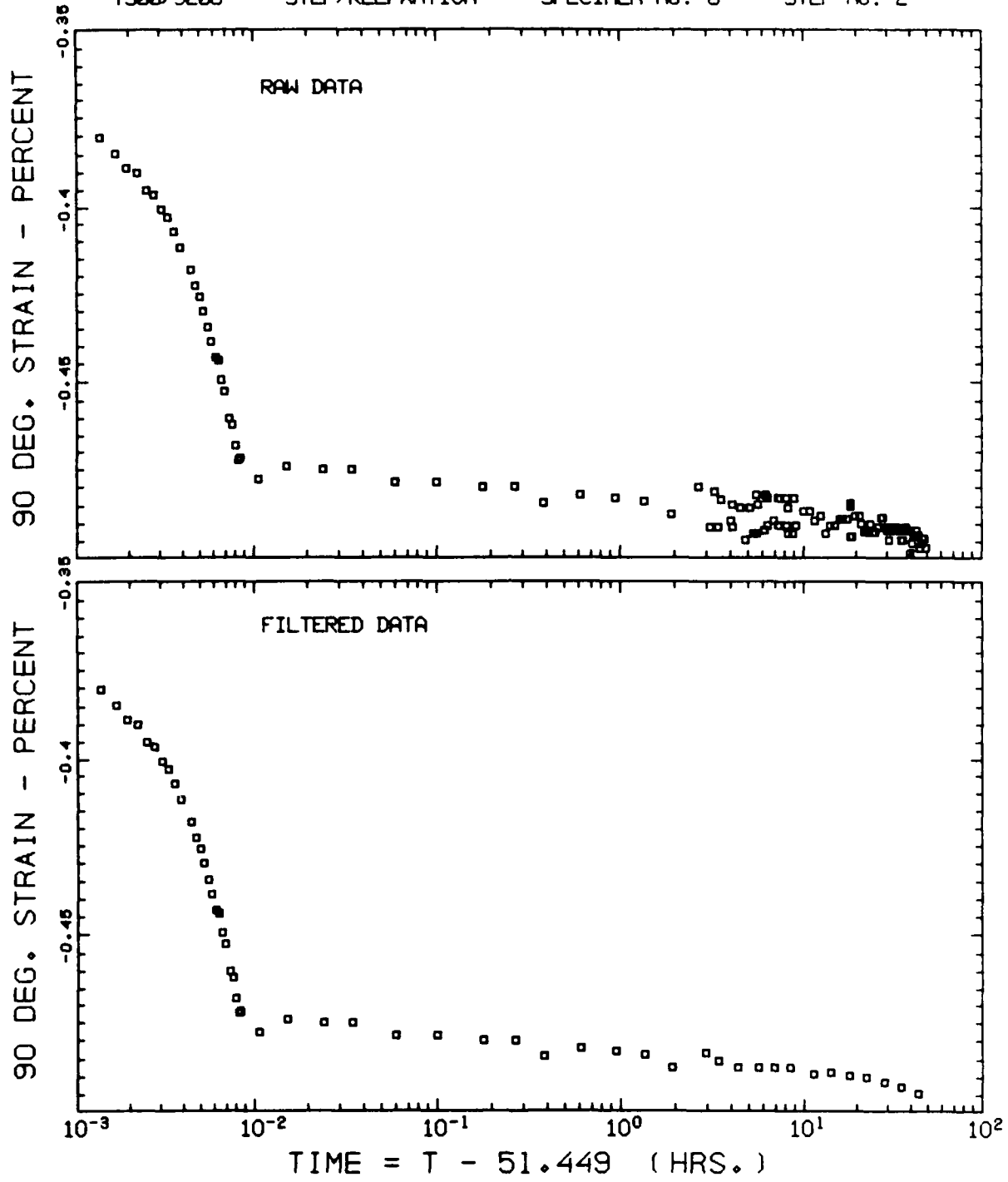

T300/5208 - STEP/RELAXATION - SPECIMEN No. 6 - STEP No. 2

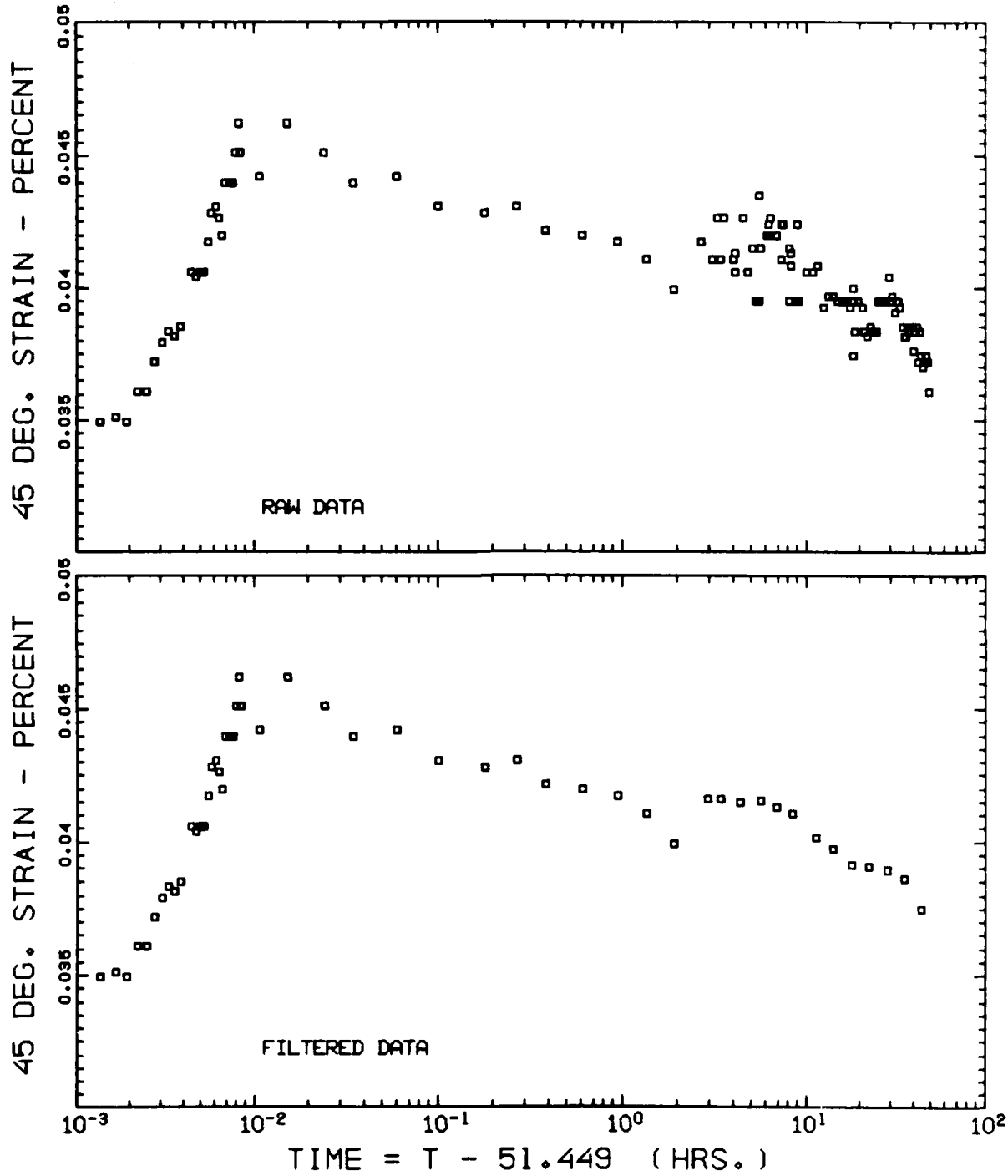

T300/5208 - STEP/RELAXATION - SPECIMEN No. 6 - STEP No. 3

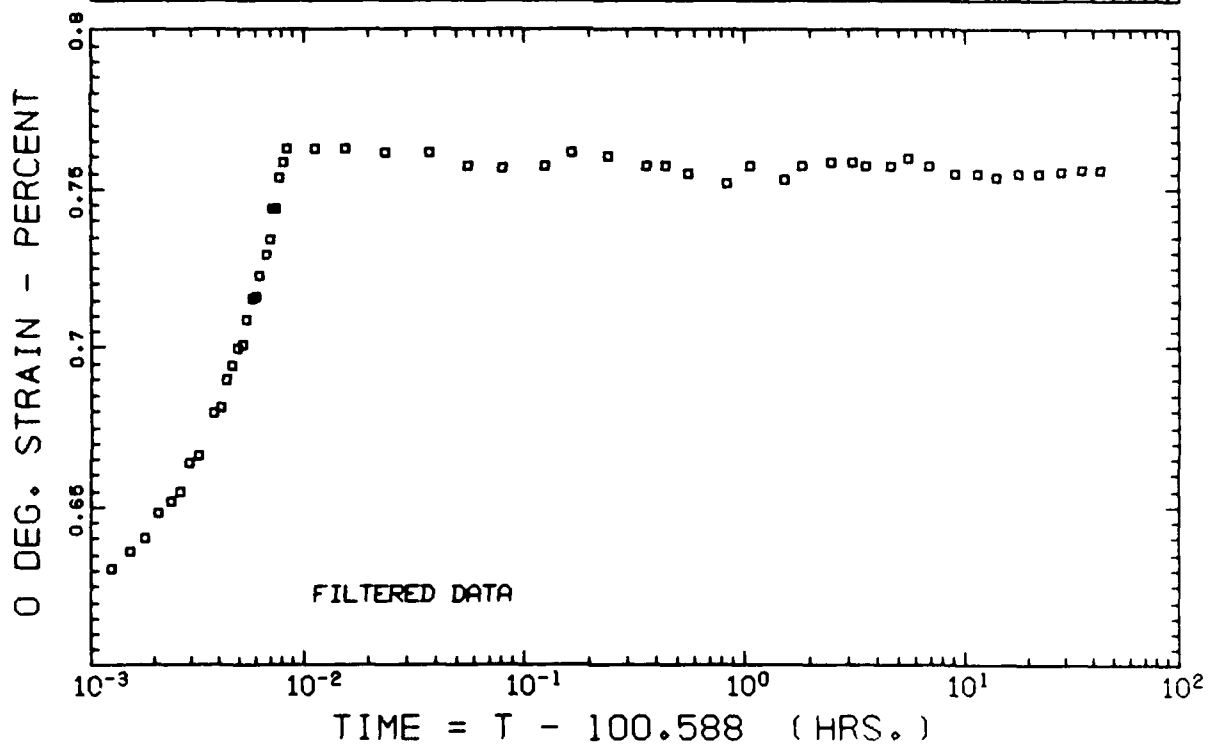
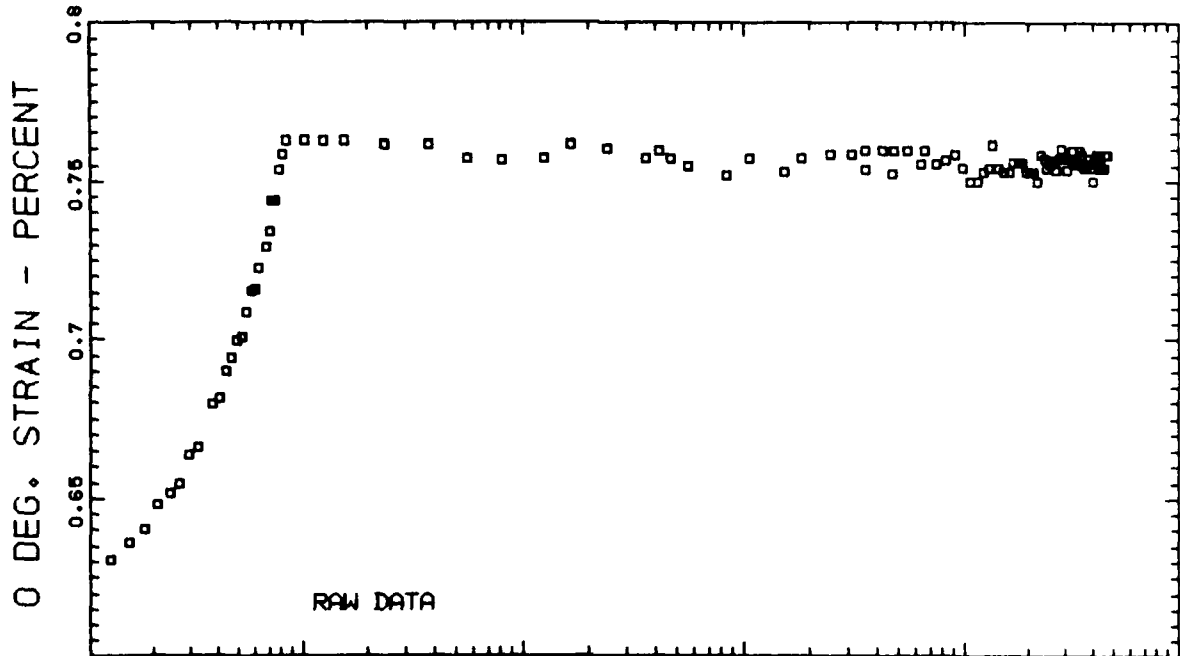

T300/5208 - STEP/RELAXATION - SPECIMEN No. 6 - STEP No. 3

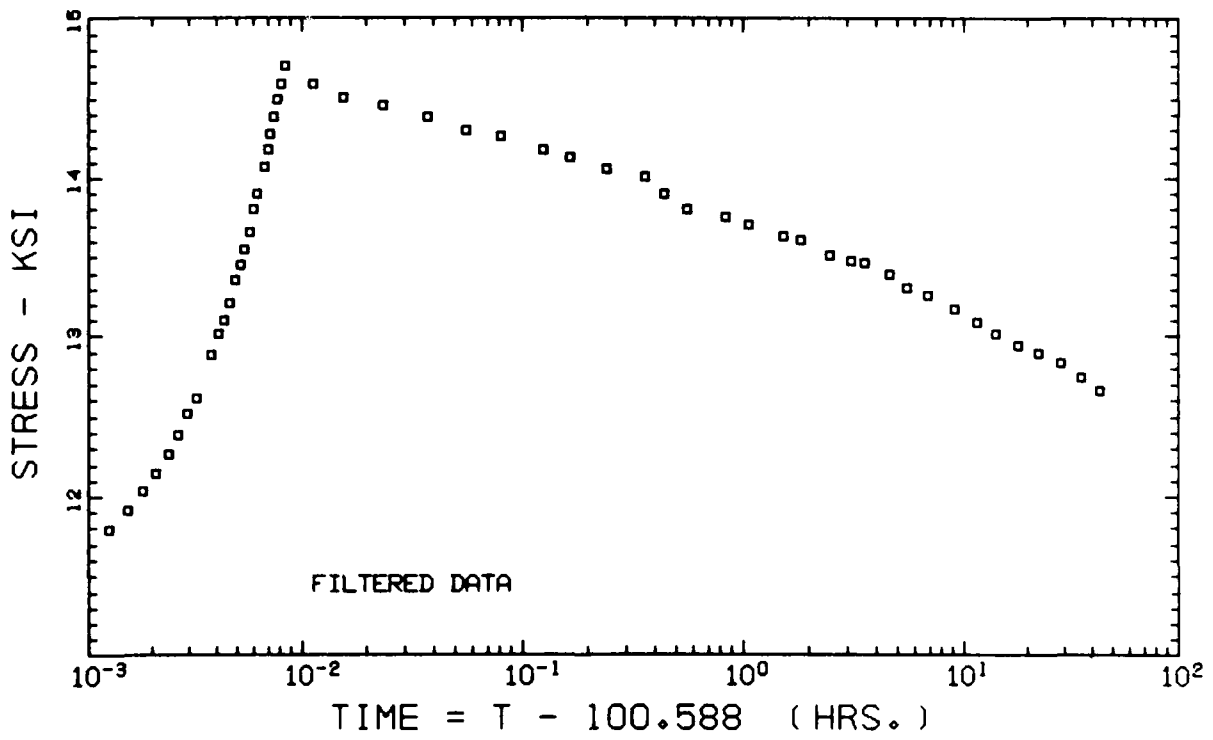
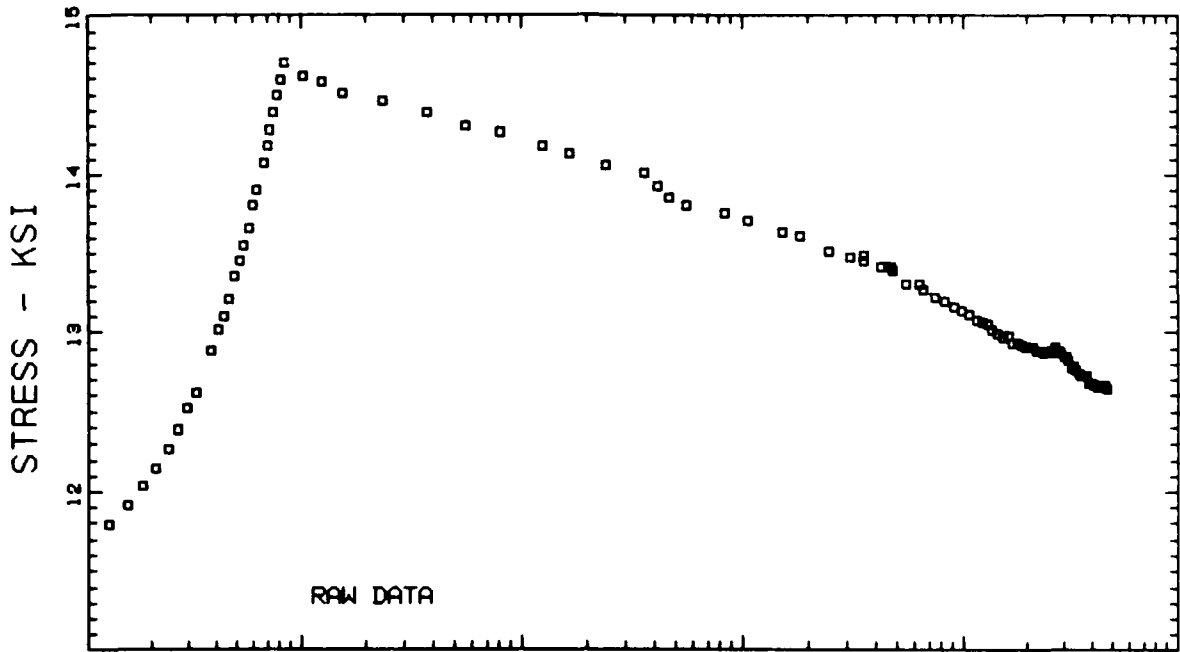

T300/5208 - STEP/RELAXATION - SPECIMEN No. 6 - STEP No. 3

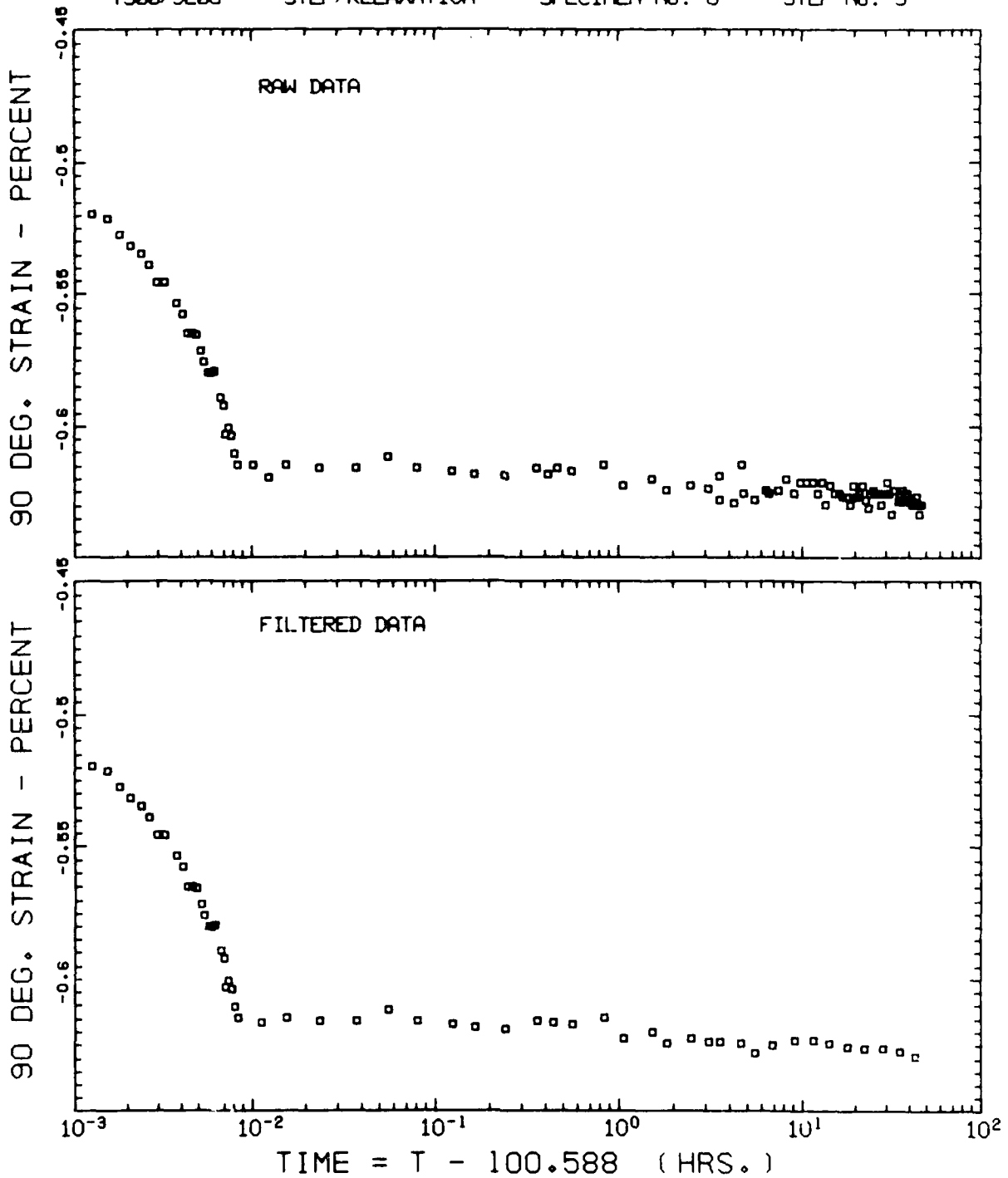



T300/5208 - STEP/RELAXATION - SPECIMEN No. 6 - STEP No. 3

45 DEG. STRAIN - PERCENT

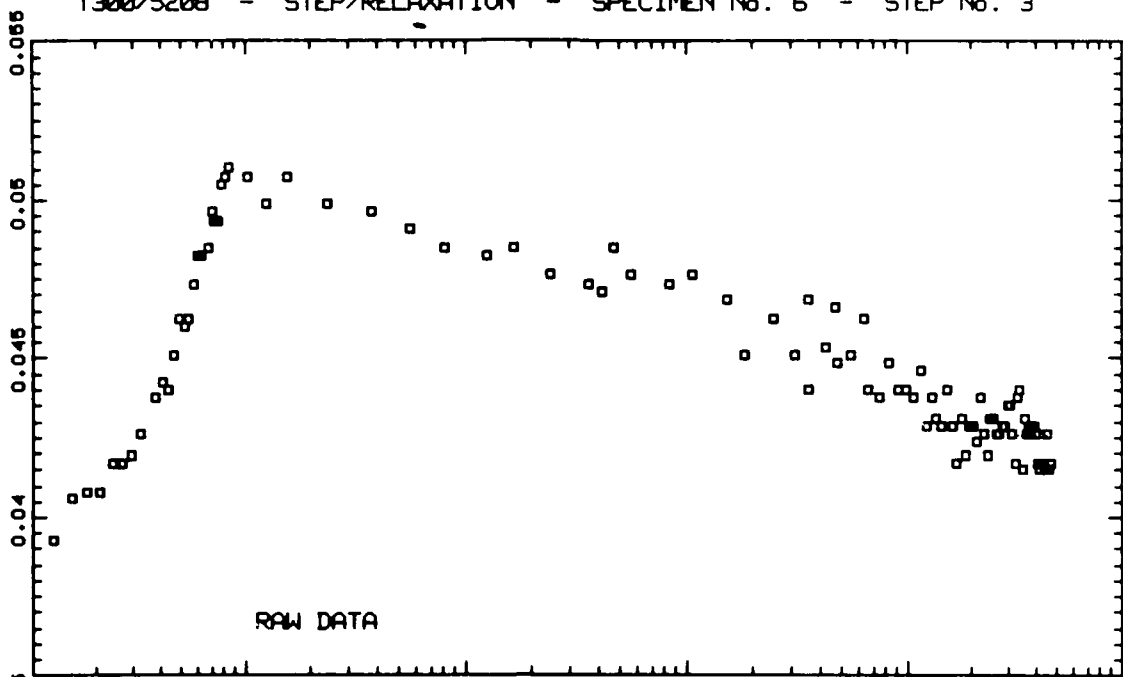

45 DEG. STRAIN - PERCENT

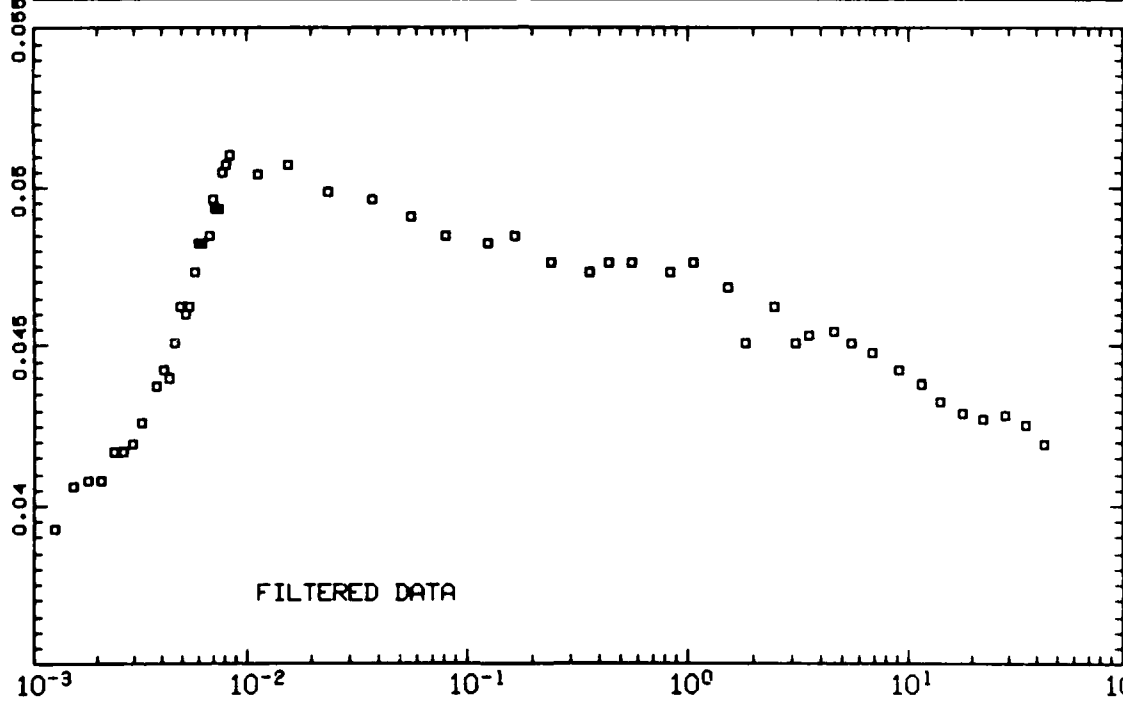

TIME = T - 100.588 (HRS.)

T300/5208 - STEP/RELAXATION - SPECIMEN No. 6 - STEP No. 4

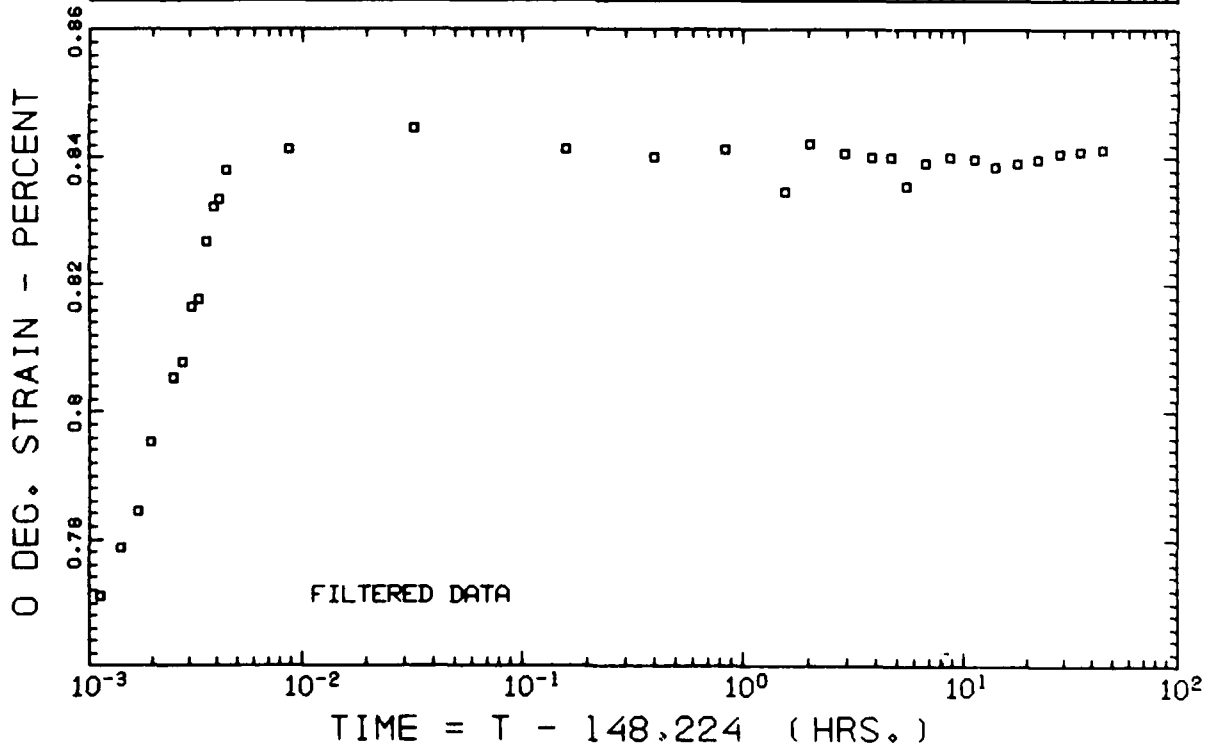
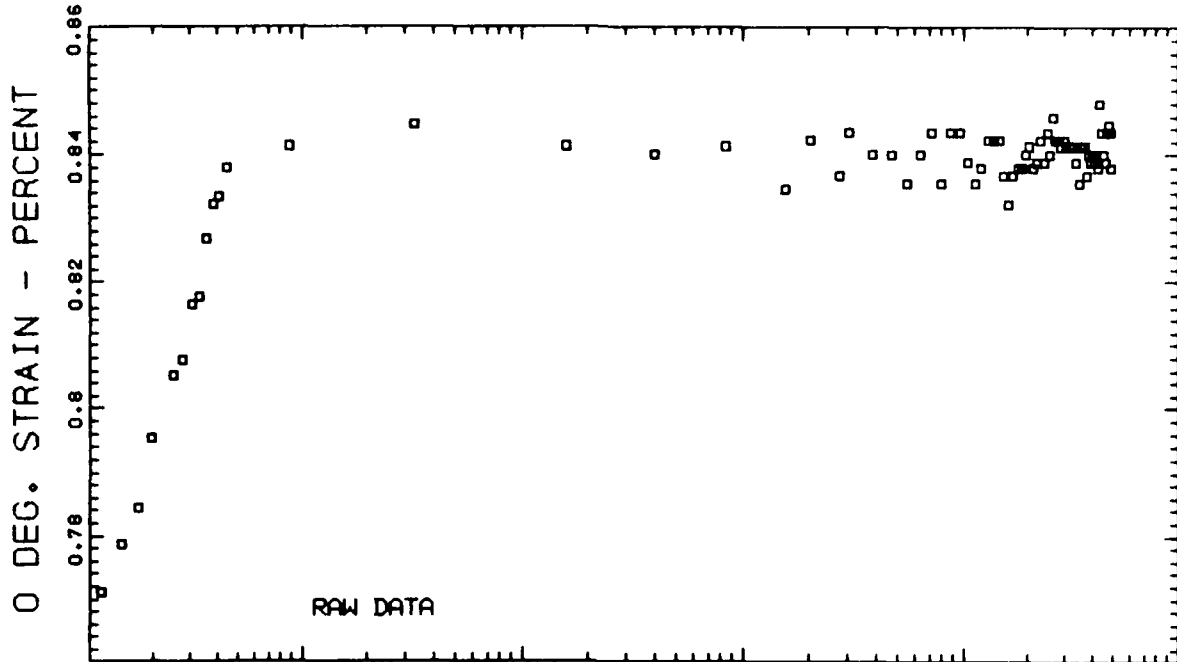

T300/S208 - STEP/RELAXATION - SPECIMEN No. 6 - STEP No. 4

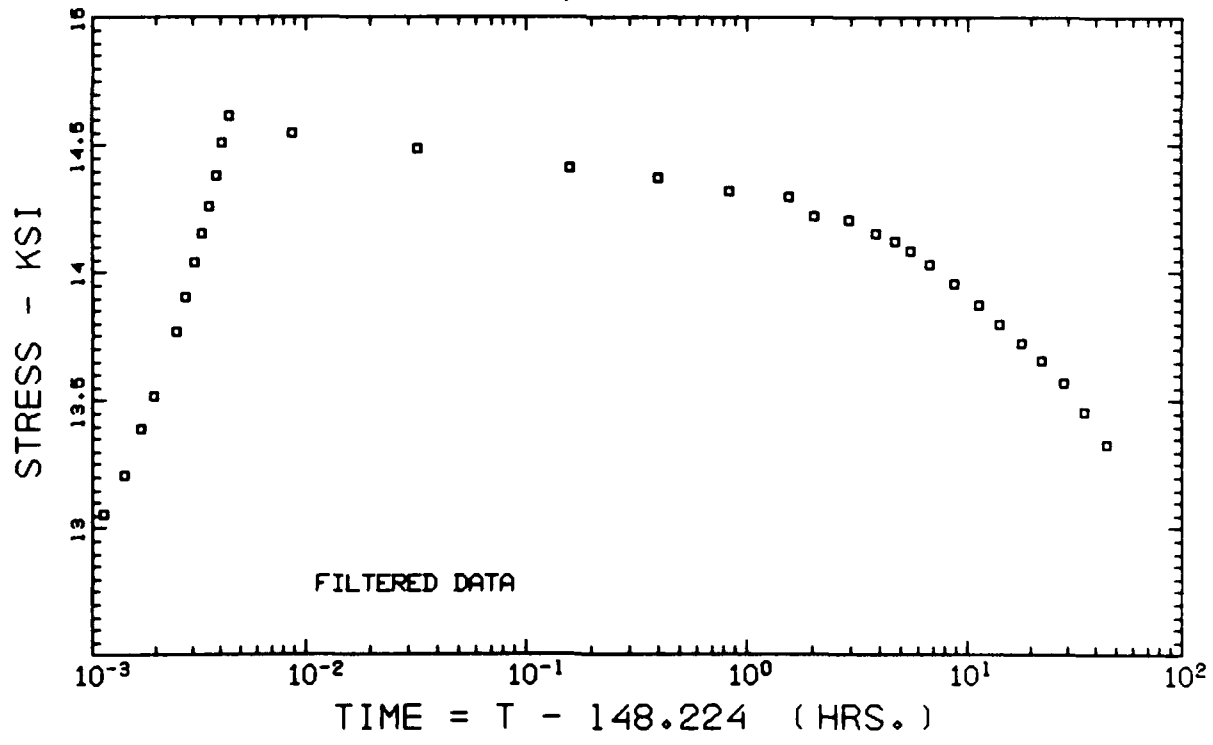
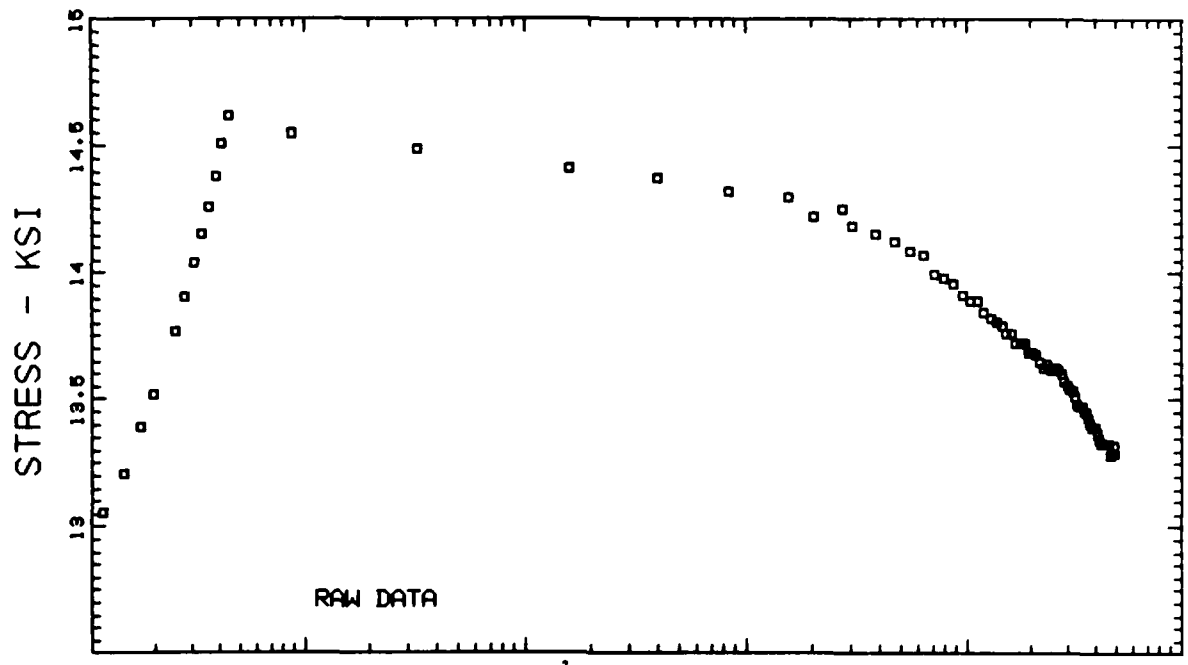

T300/5208 - STEP/RELAXATION - SPECIMEN No. 6 - STEP No. 4

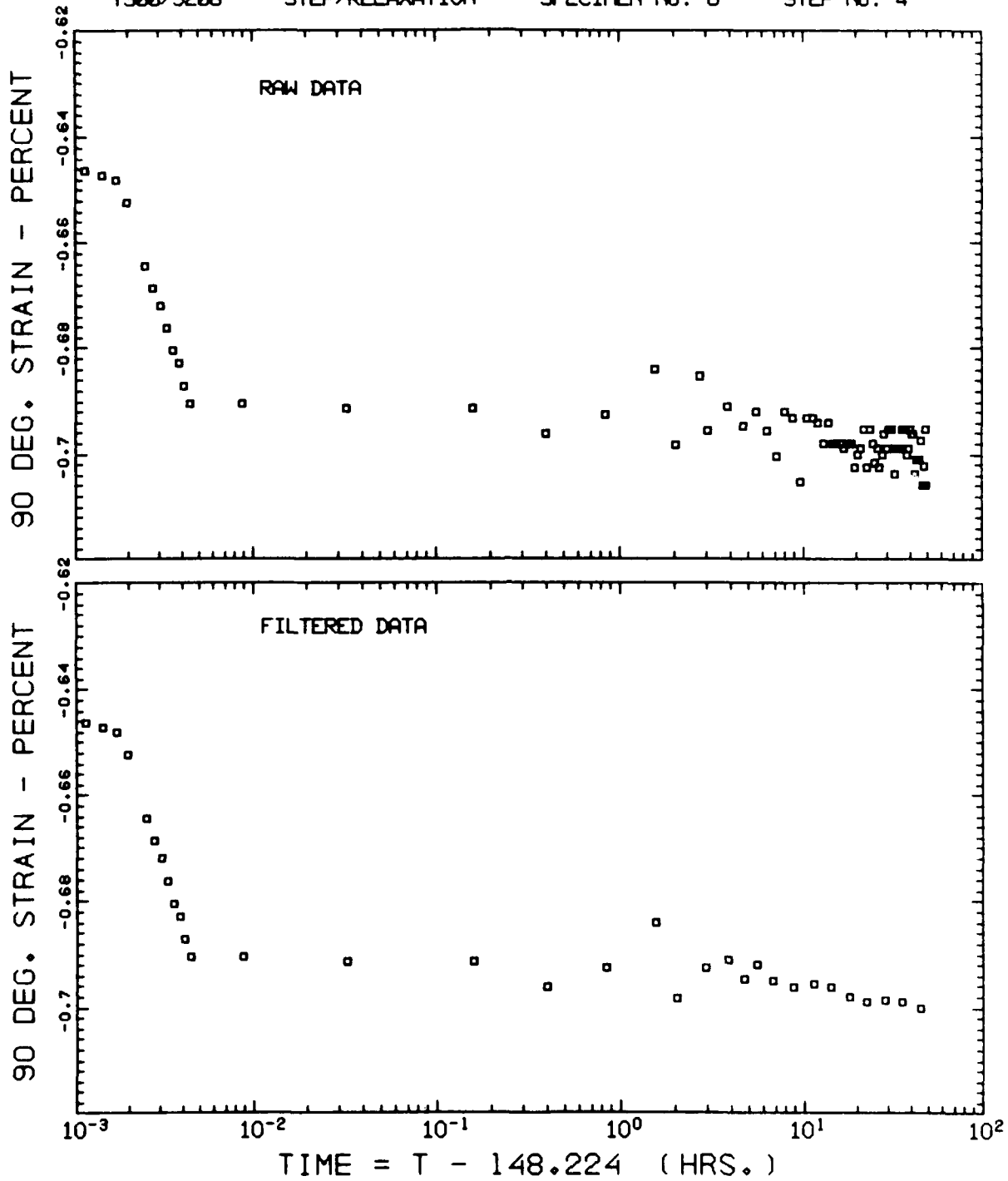

T300/5208 - STEP/RELAXATION - SPECIMEN No. 6 - STEP No. 4

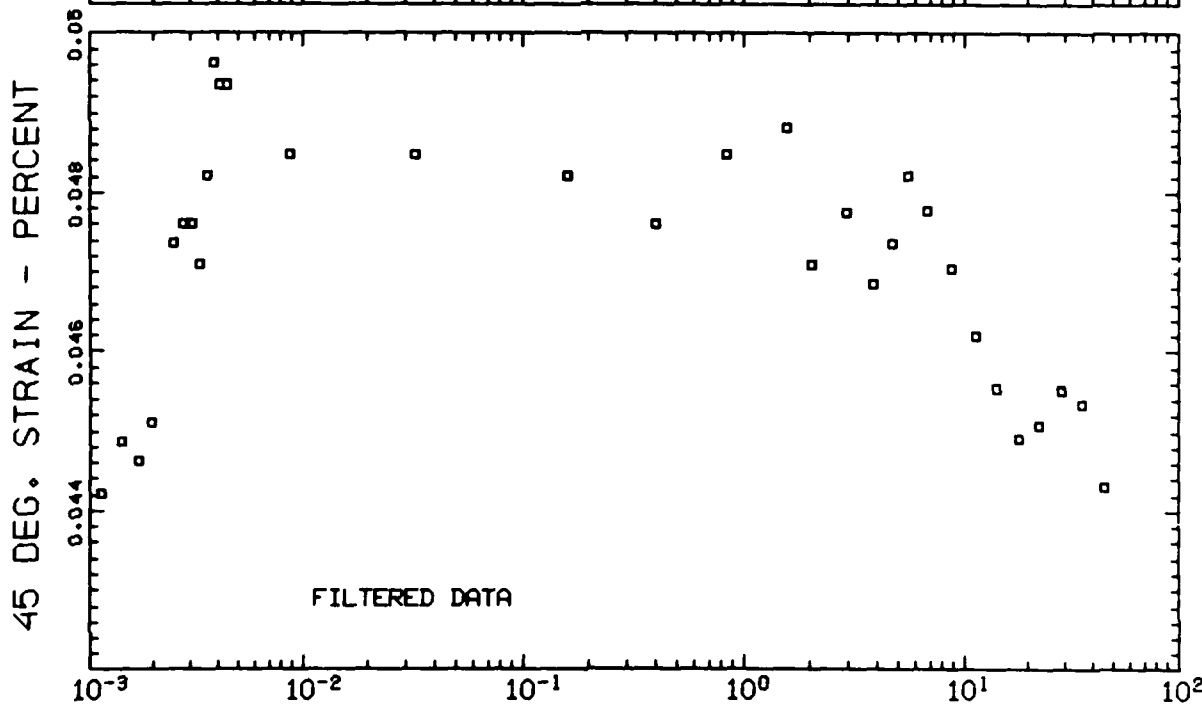
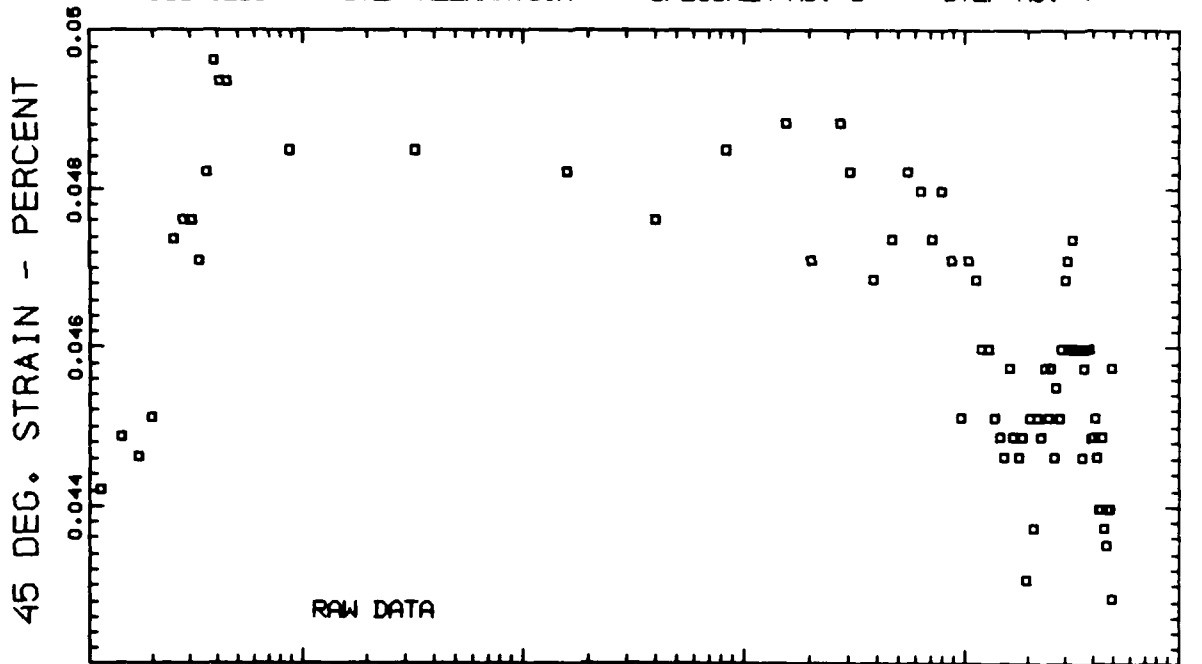

TIME = T - 148.224 (HRS.)

T300/5208 - STEP/RELAXATION - SPECIMEN No. 6 - STEP No. 5

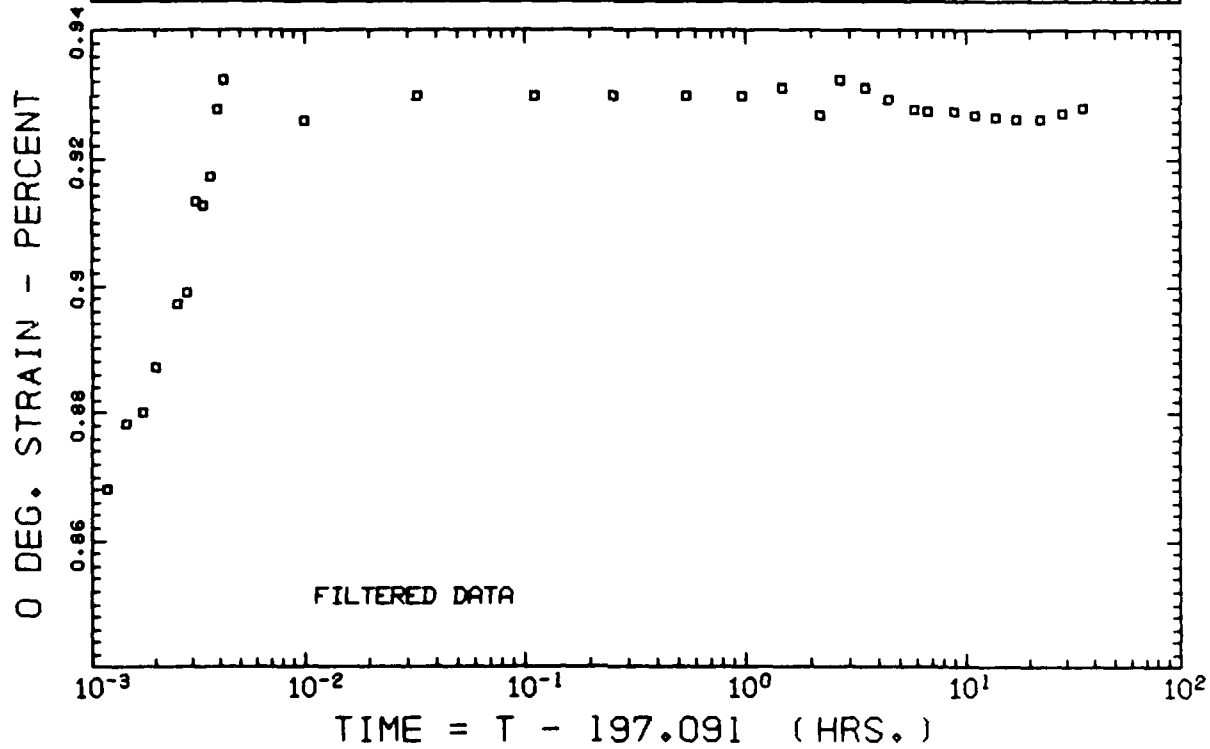
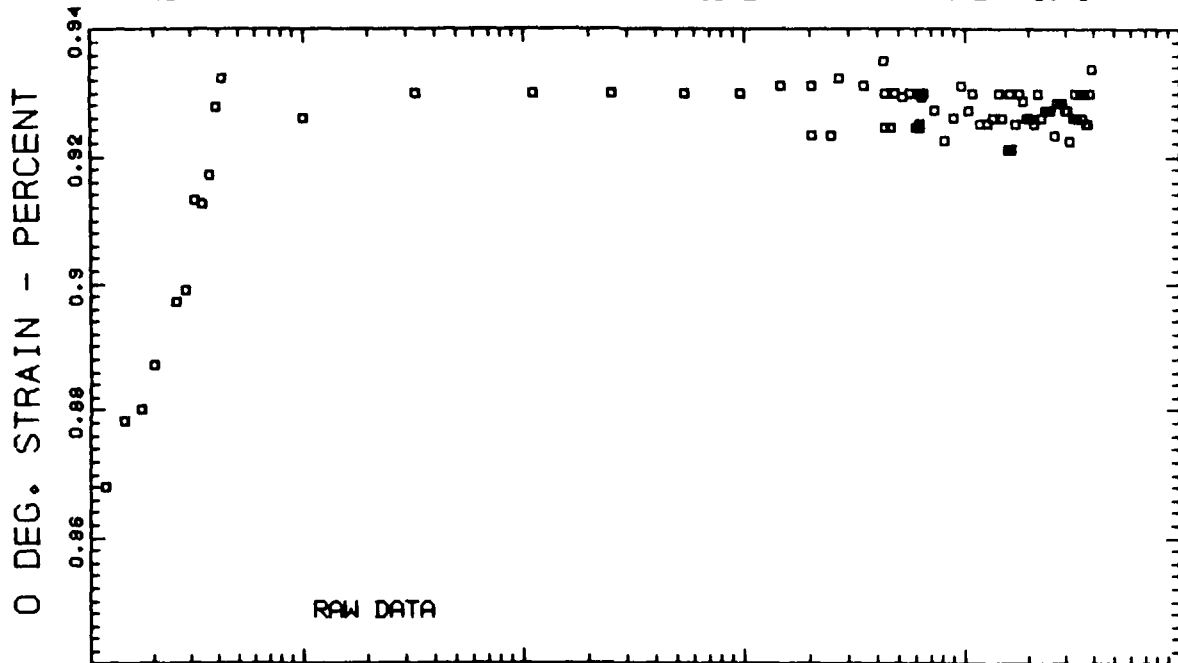

T300/5208 - STEP/RELAXATION - SPECIMEN No. 6 - STEP No. 5

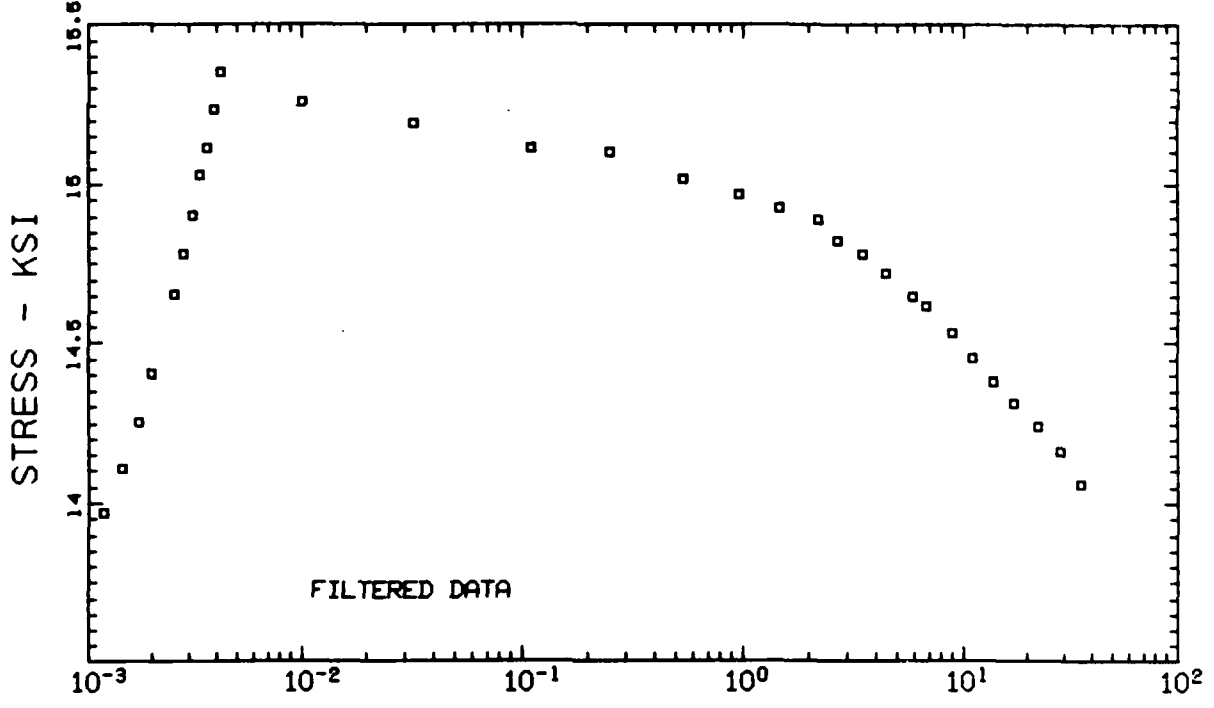
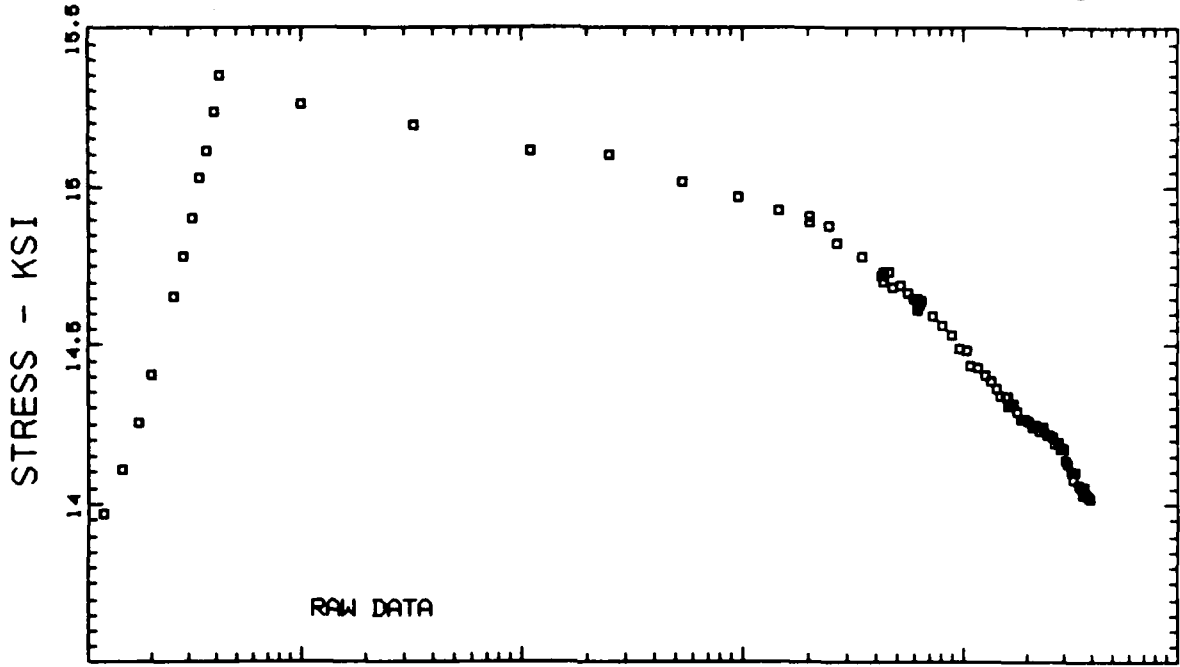

TIME = T - 197.091 (HRS.)

T300/5208 - STEP/RELAXATION - SPECIMEN No. 6 - STEP No. 5

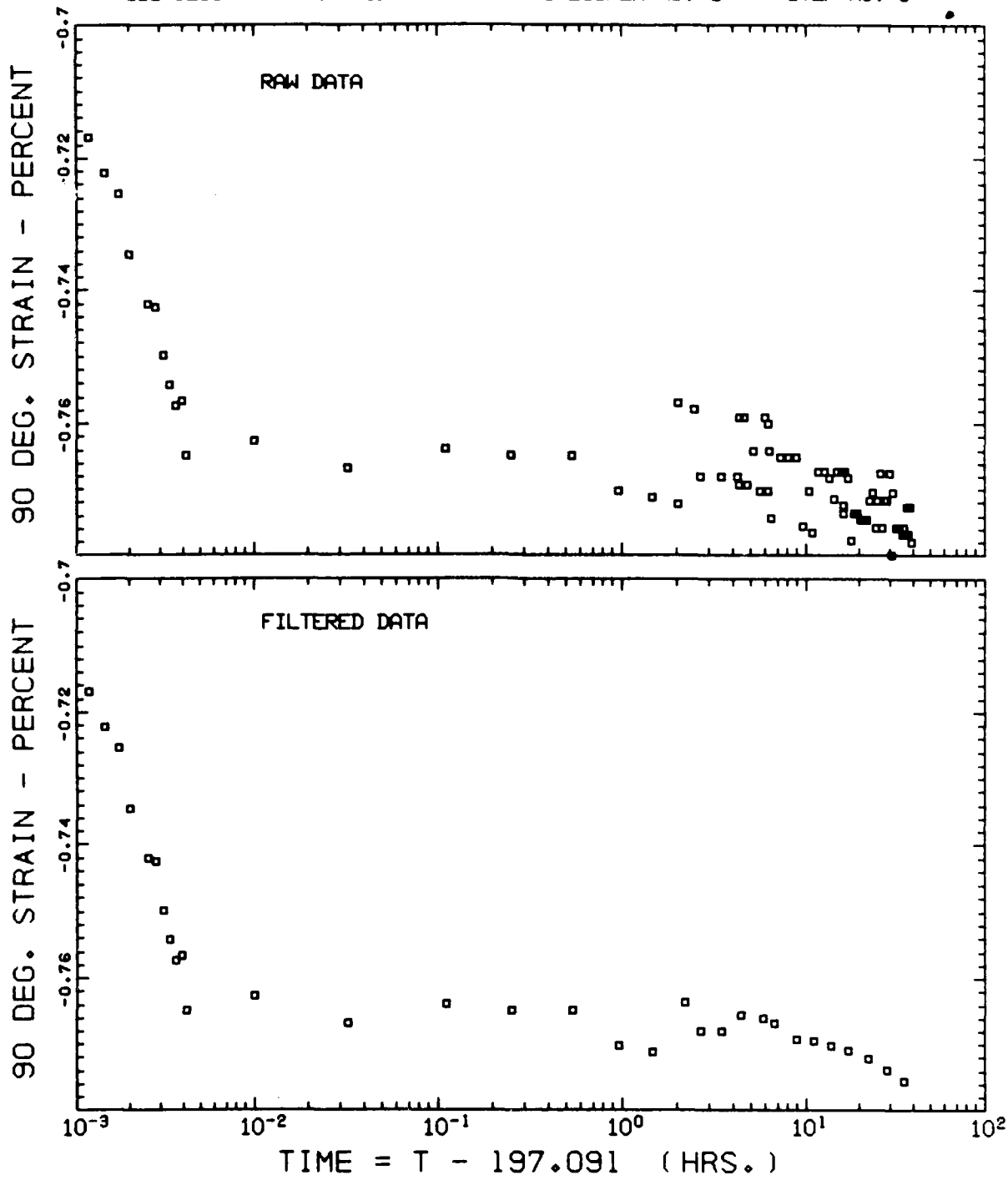



T300/S208 - STEP/RELAXATION - SPECIMEN No. 6 - STEP No. 5

45 DEG. STRAIN - PERCENT

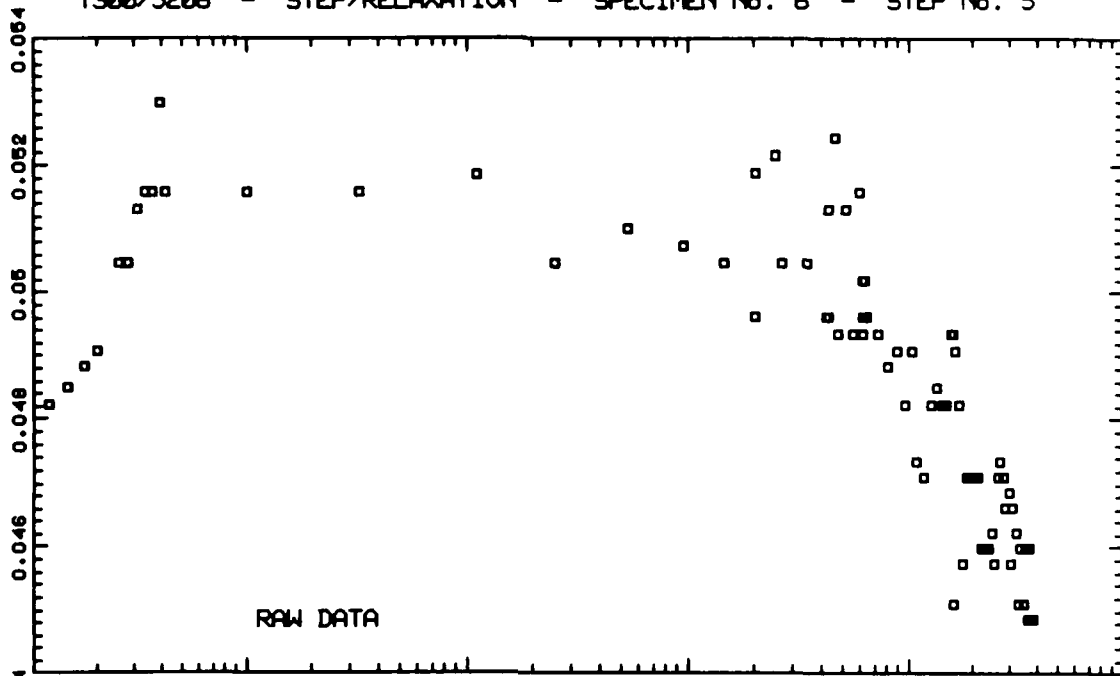

45 DEG. STRAIN - PERCENT

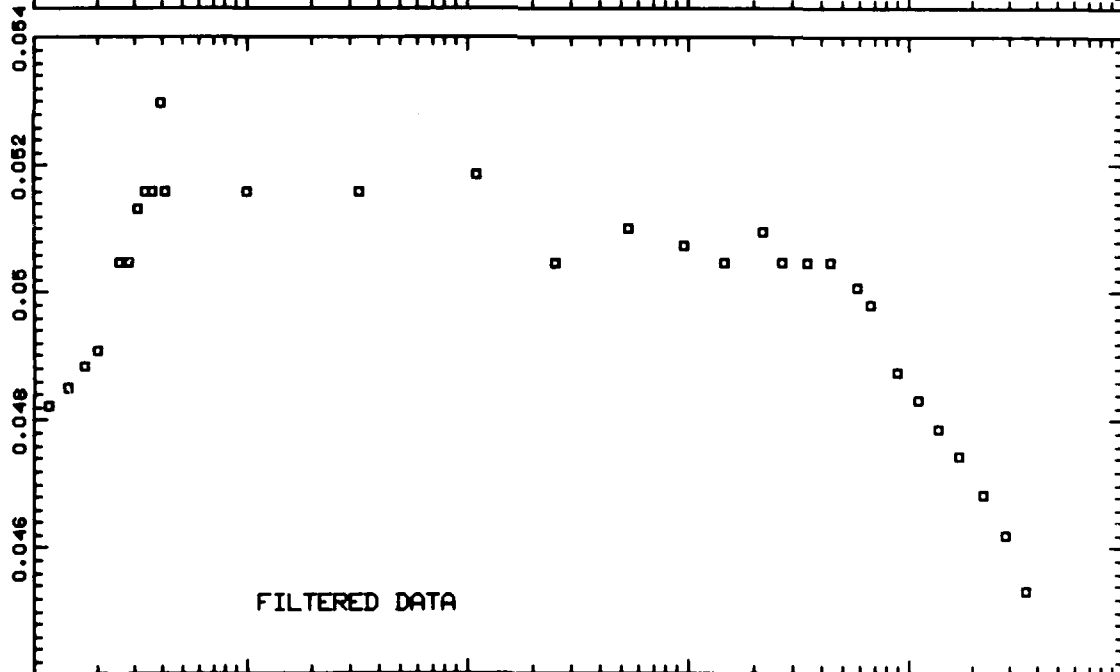

TIME = T - 197.091 (HRS.)

T300/5208 - STEP/RELAXATION - SPECIMEN No. 6 - STEP No. 6

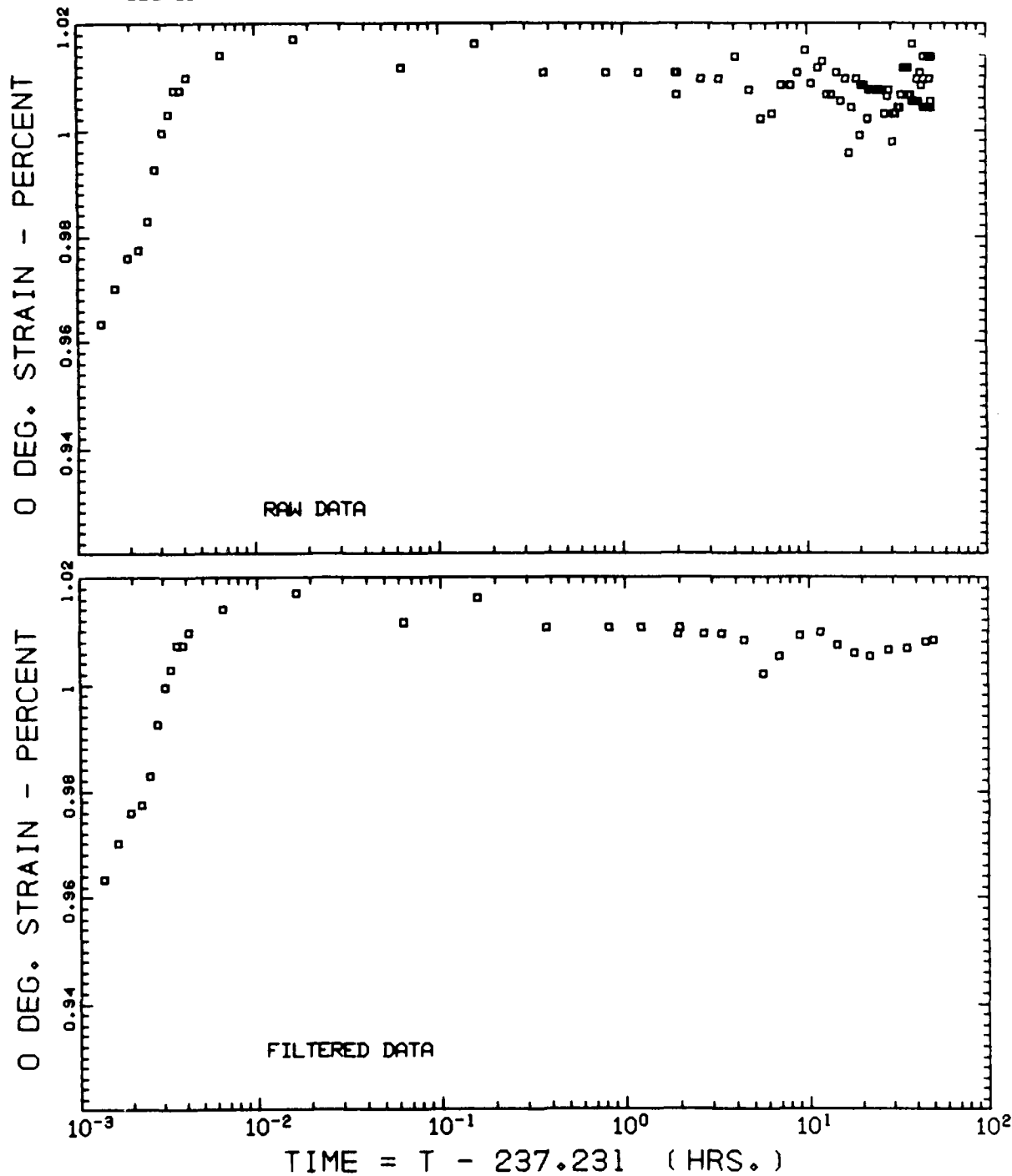

T300/5208 - STEP RELAXATION - SPECIMEN No. 6 - STEP No. 6

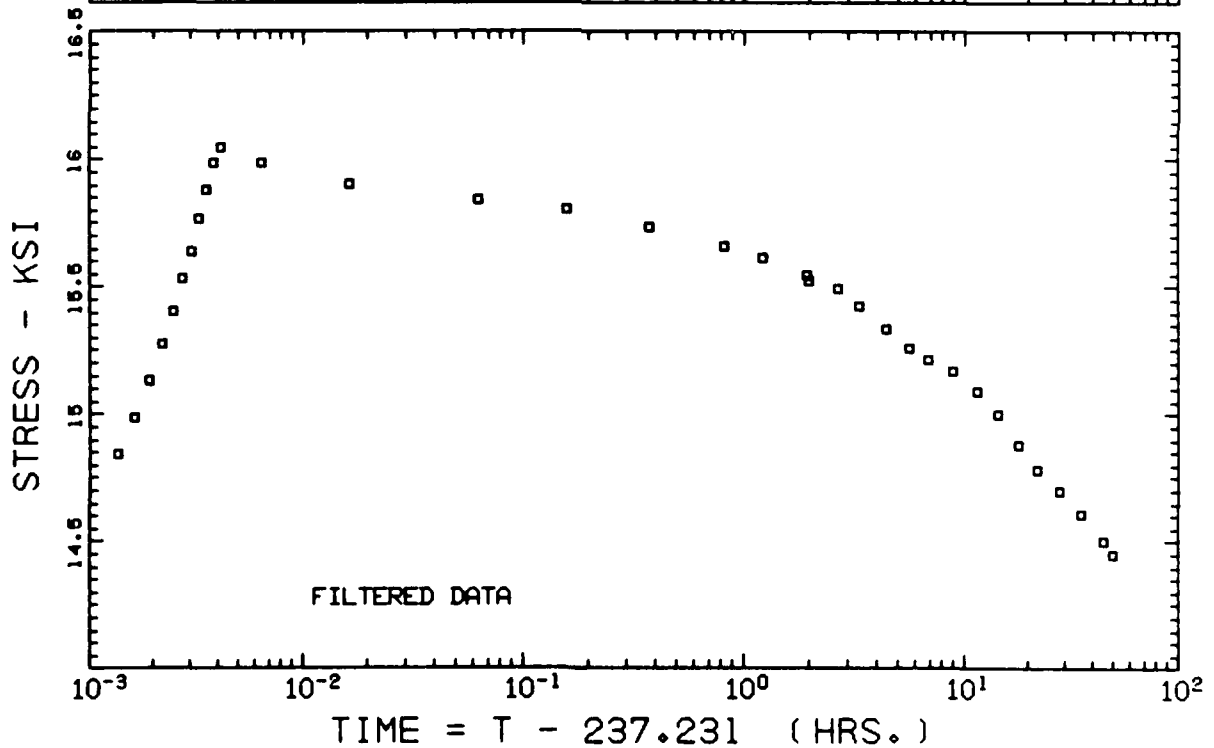
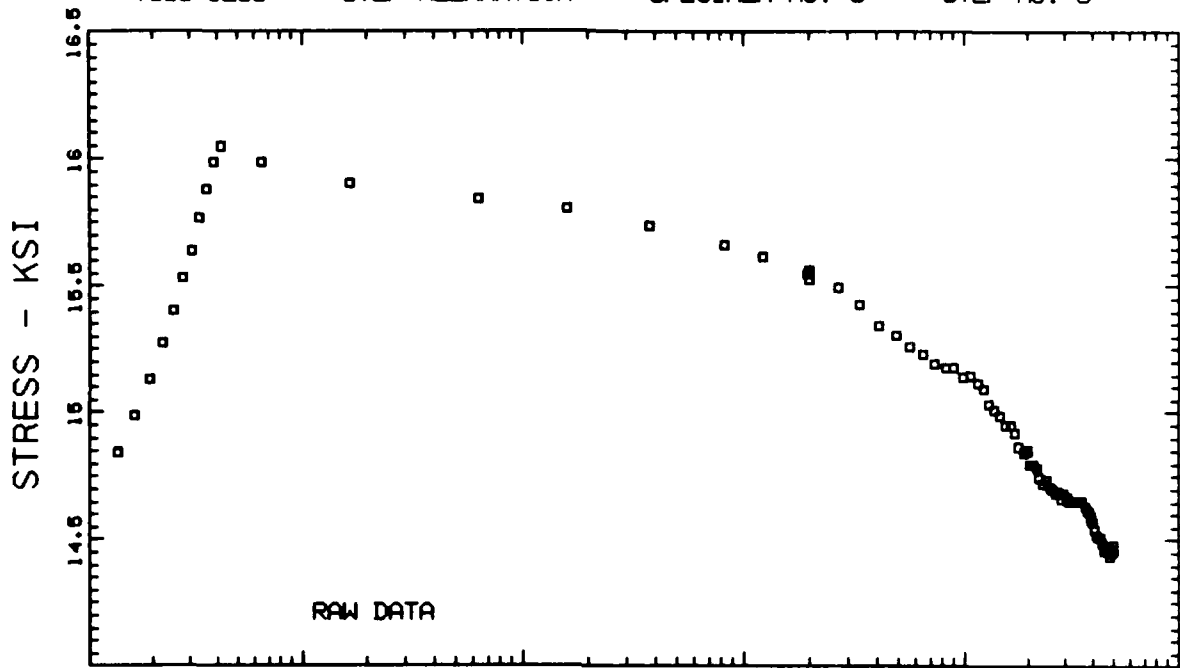

T300/5208 - STEP/RELAXATION - SPECIMEN No. 6 - STEP No. 6

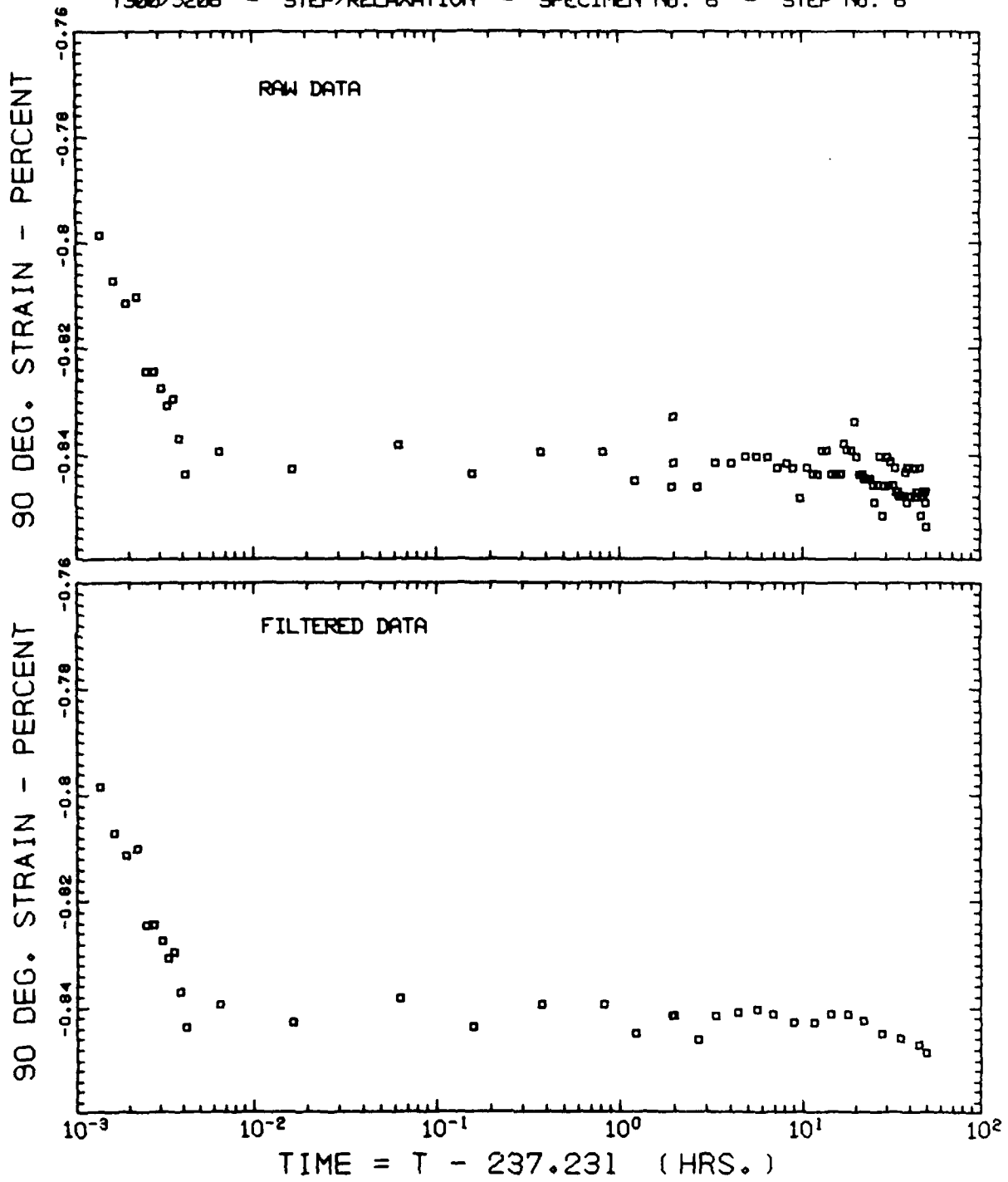

TJ00/S208 - STEP/RELAXATION - SPECIMEN No. 6 - STEP No. 6

45 DEG. STRAIN - PERCENT

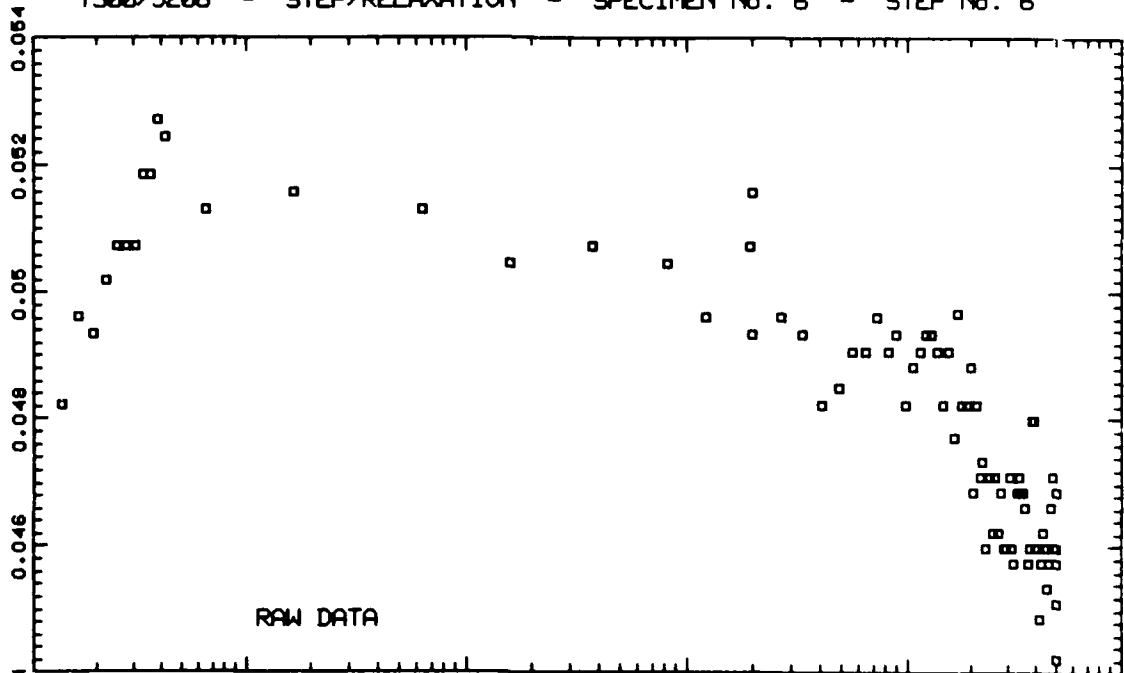

45 DEG. STRAIN - PERCENT

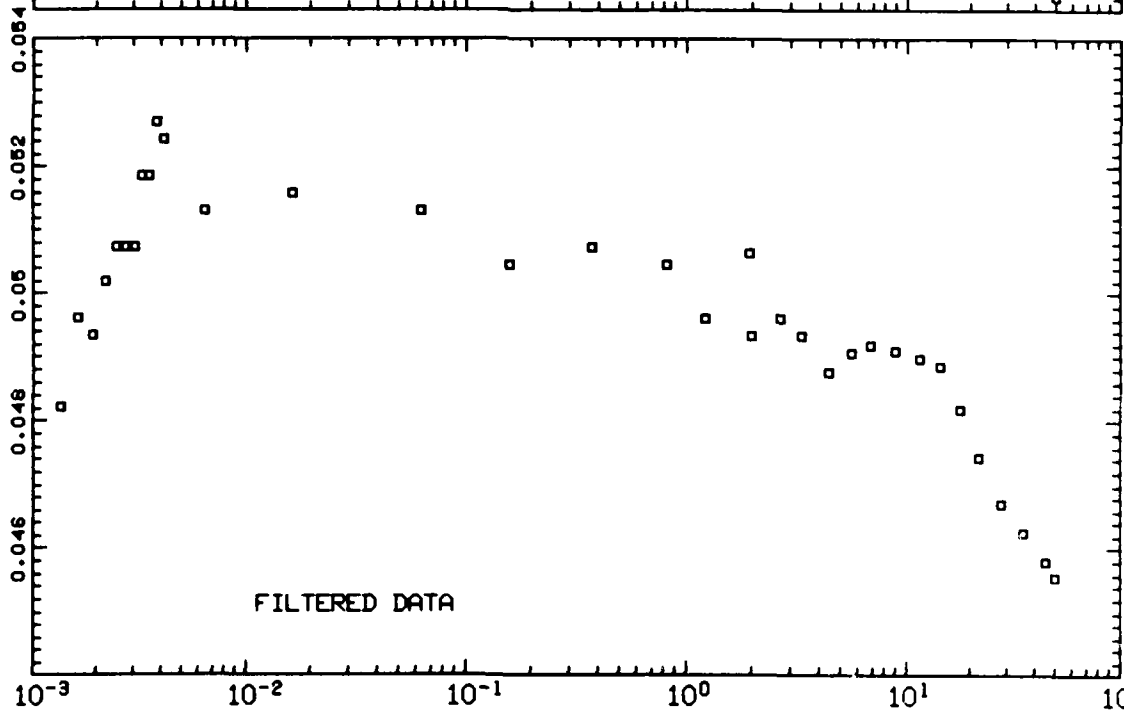

TIME = T - 237.231 (HRS.)

AD-A141 697

MATRIX-DOMINATED TIME-DEPENDENT DEFORMATION AND DAMAGE  
OF GRAPHITE EPOXY. (U) LAWRENCE LIVERMORE NATIONAL LAB  
CA E M WU ET AL. MAY 83 UCID-19765 AFNL-TR-83-3056

3/6

UNCLASSIFIED

W-7405-ENG-48

F/G 11/9

NL

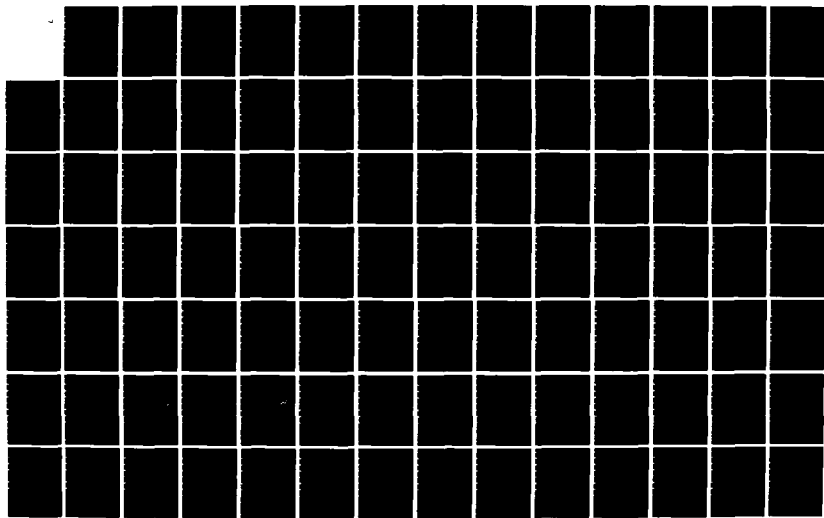

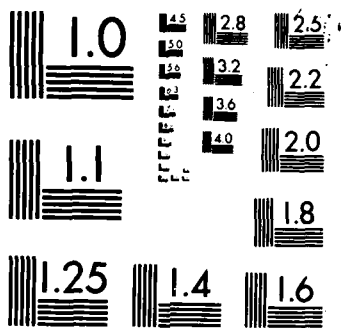

MICROCOPY RESOLUTION TEST CHART  
NATIONAL BUREAU OF STANDARDS 1963-A

T300/5208 - STEP/RELAXATION - SPECIMEN No. 6 - STEP No. 7

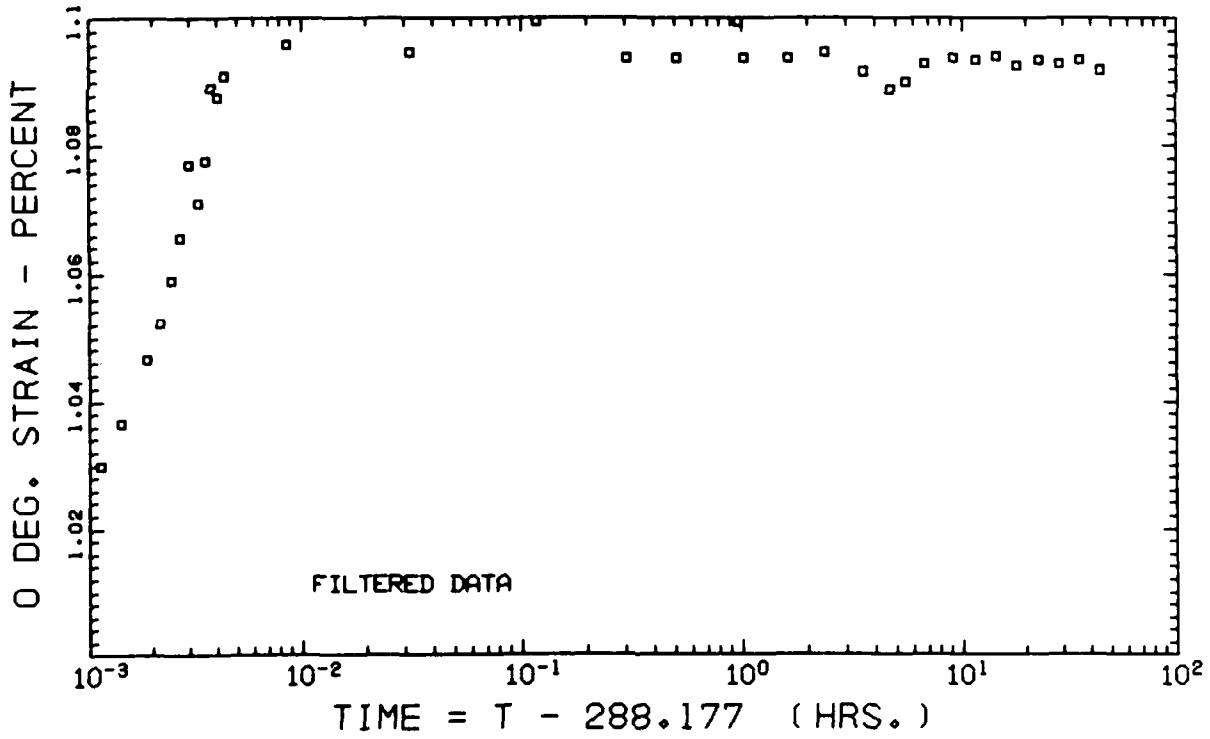
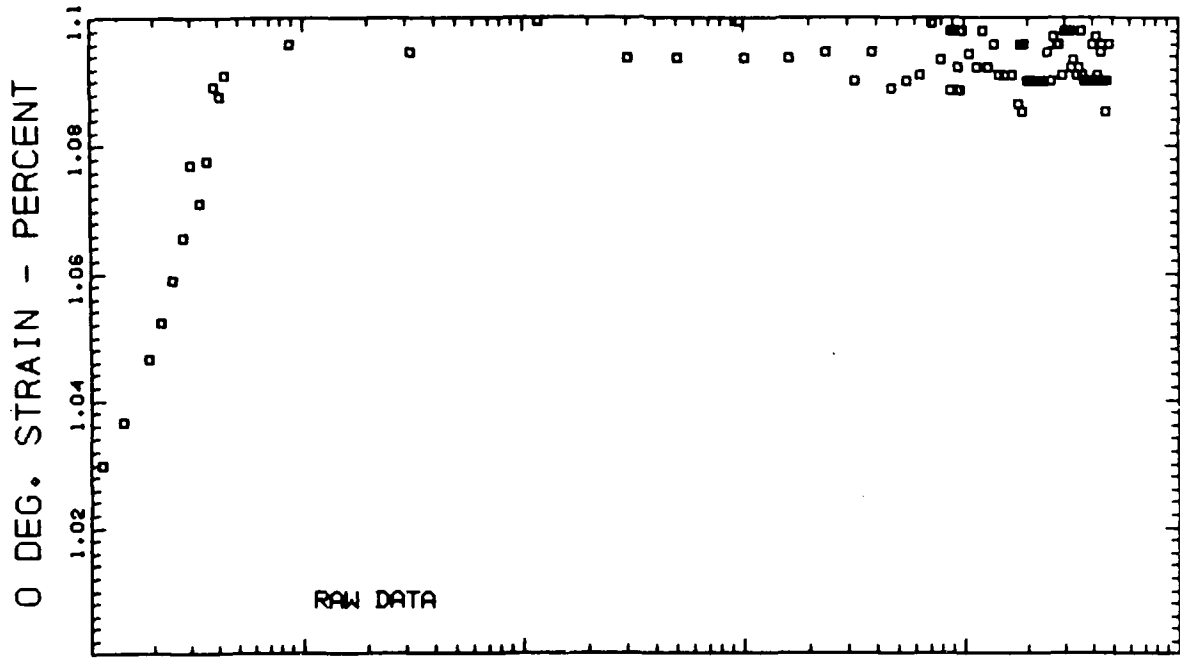



T300/S208 - STEP/RELAXATION - SPECIMEN No. 6 - STEP No. 7

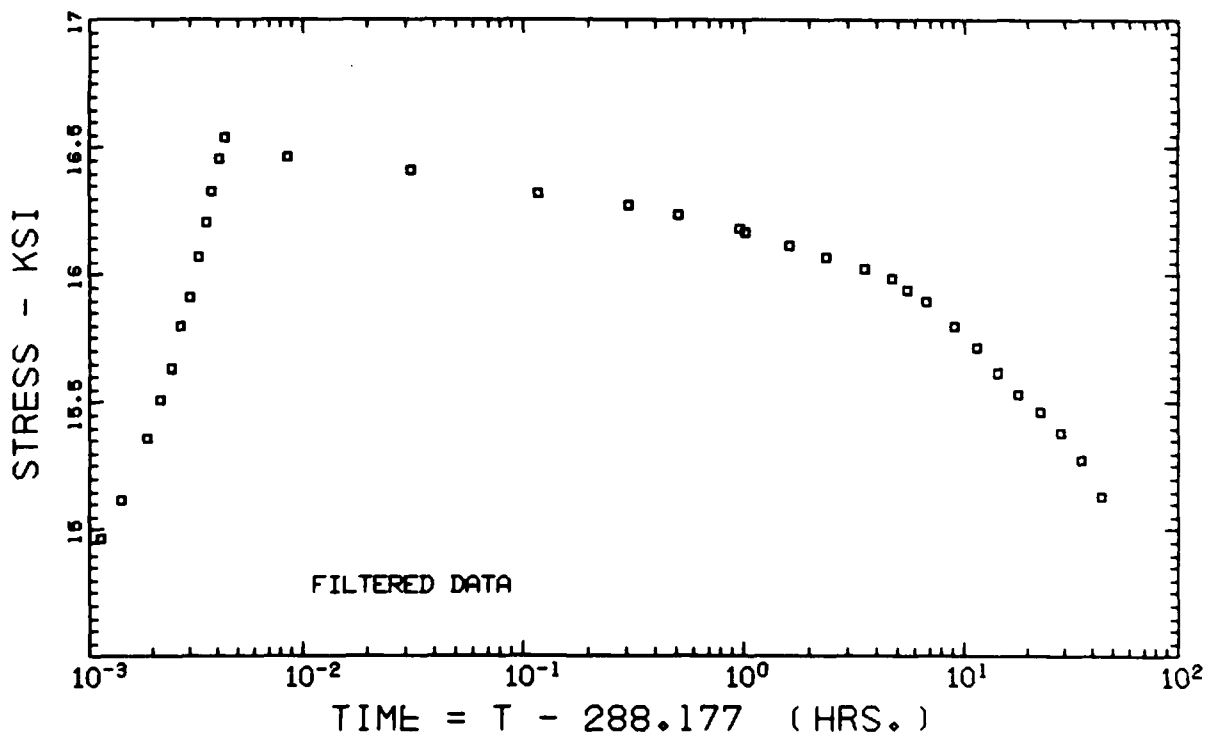
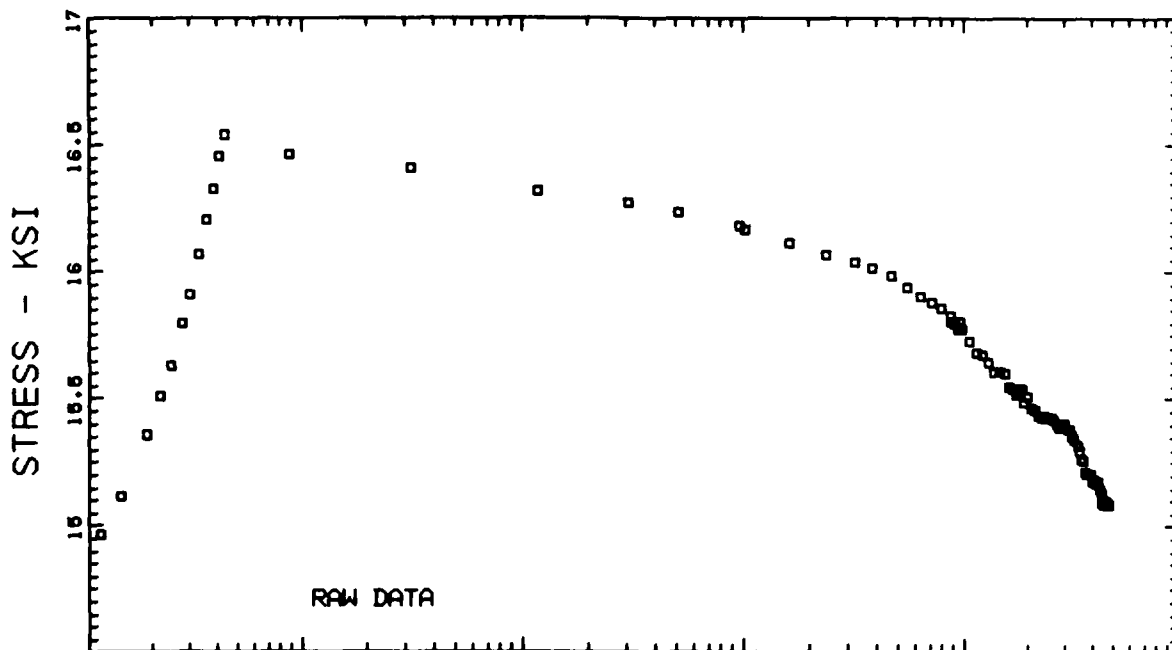

T300/5208 - STEP/RELAXATION - SPECIMEN No. 6 - STEP No. 7

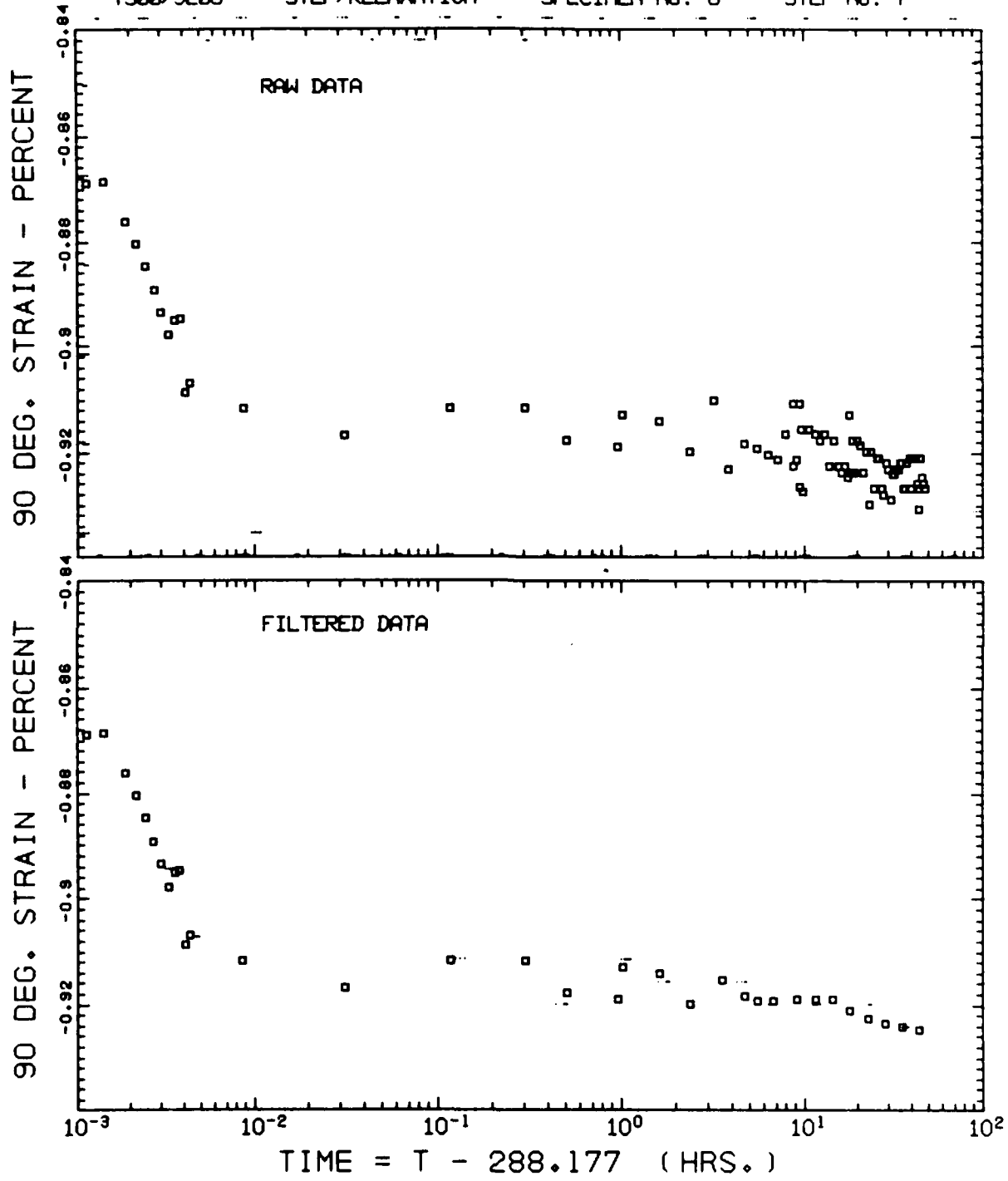

T300/520E - STEP/RELAXATION - SPECIMEN No. 6 - STEP No. 7

45 DEG. STRAIN - PERCENT

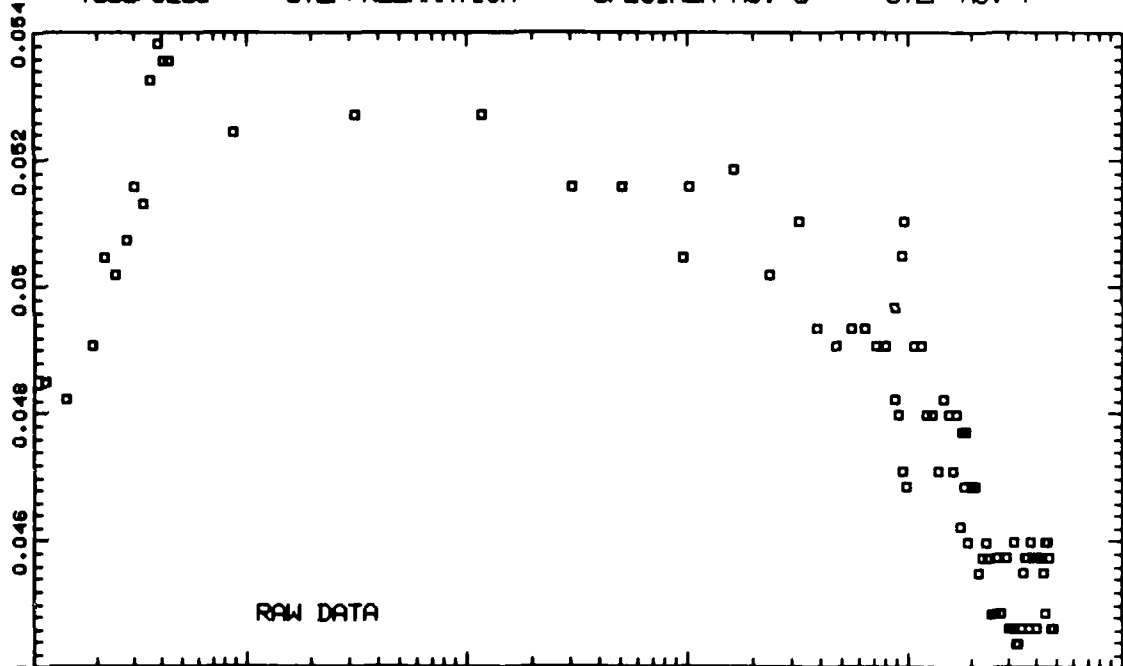

45 DEG. STRAIN - PERCENT

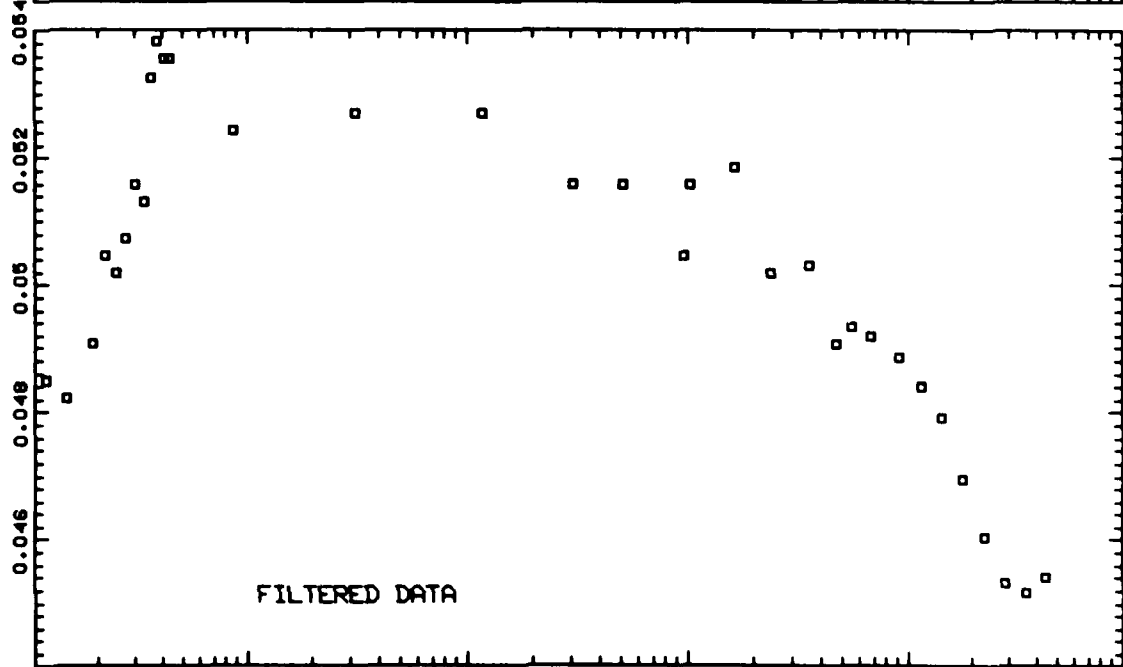

TIME = T - 288.177 (HRS.)

T300/5208 - STEP/RELAXATION - SPECIMEN No. 6 - STEP No. 8

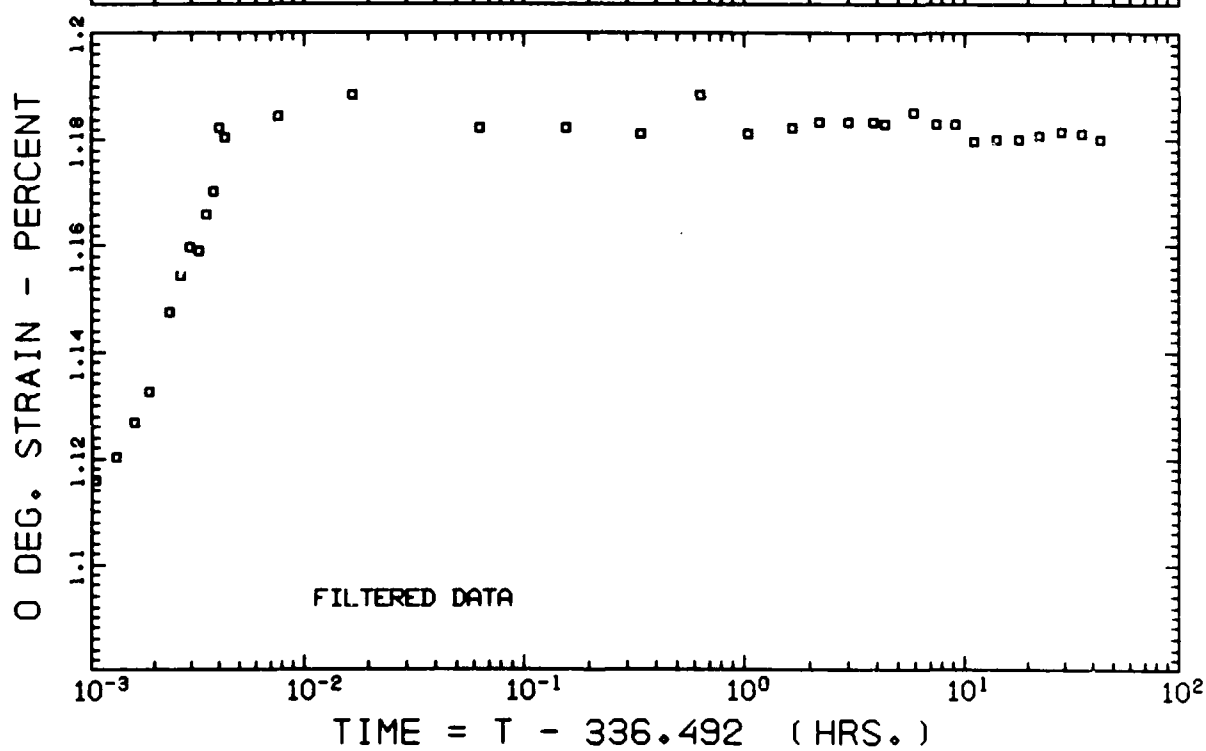
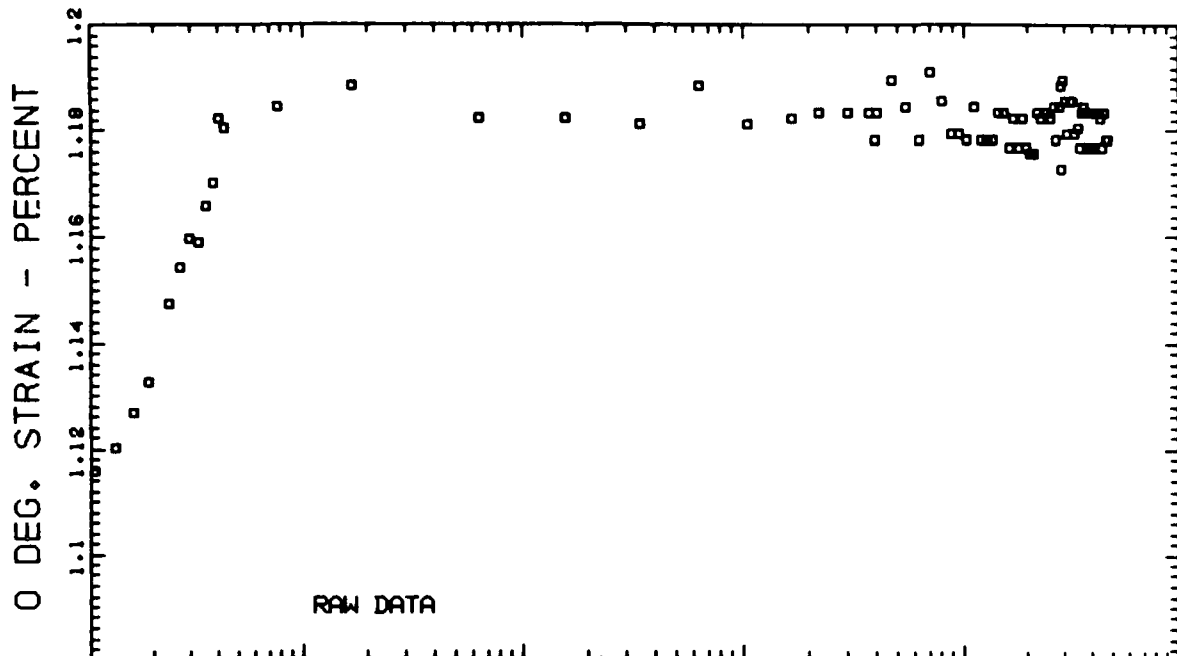

T300/5208 - STEP/RELAXATION - SPECIMEN No. 6 - STEP No. 8

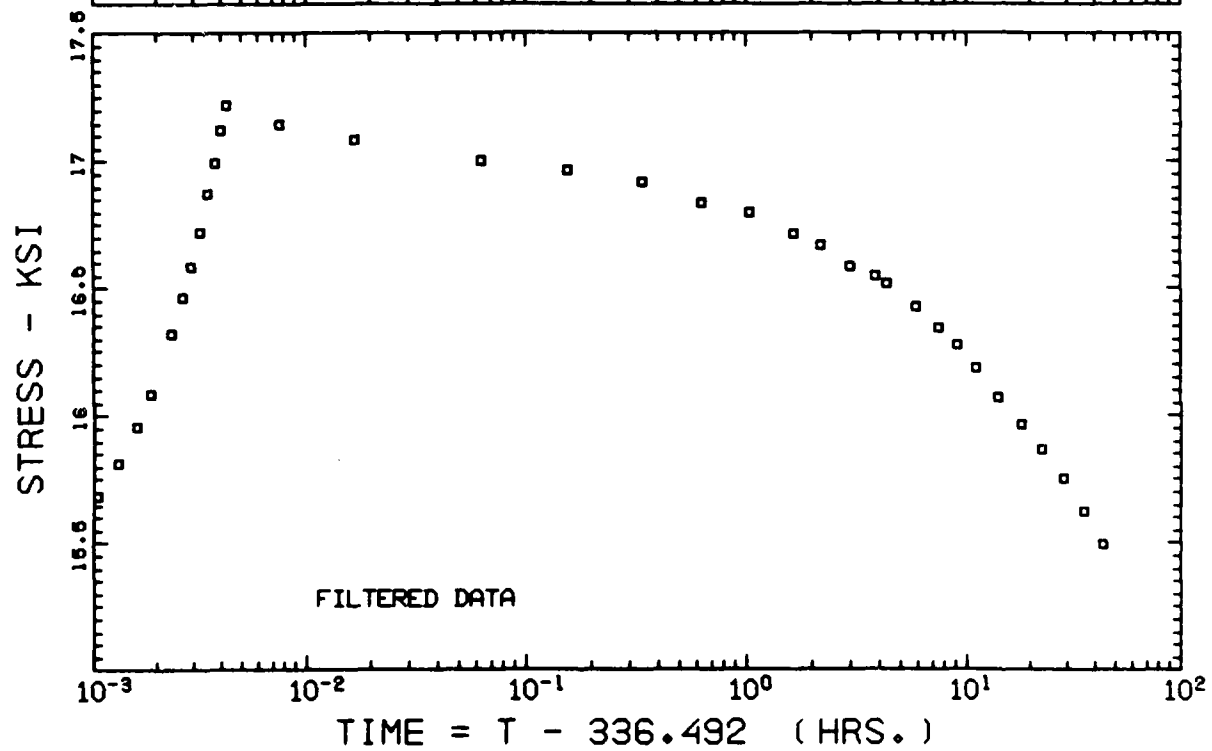
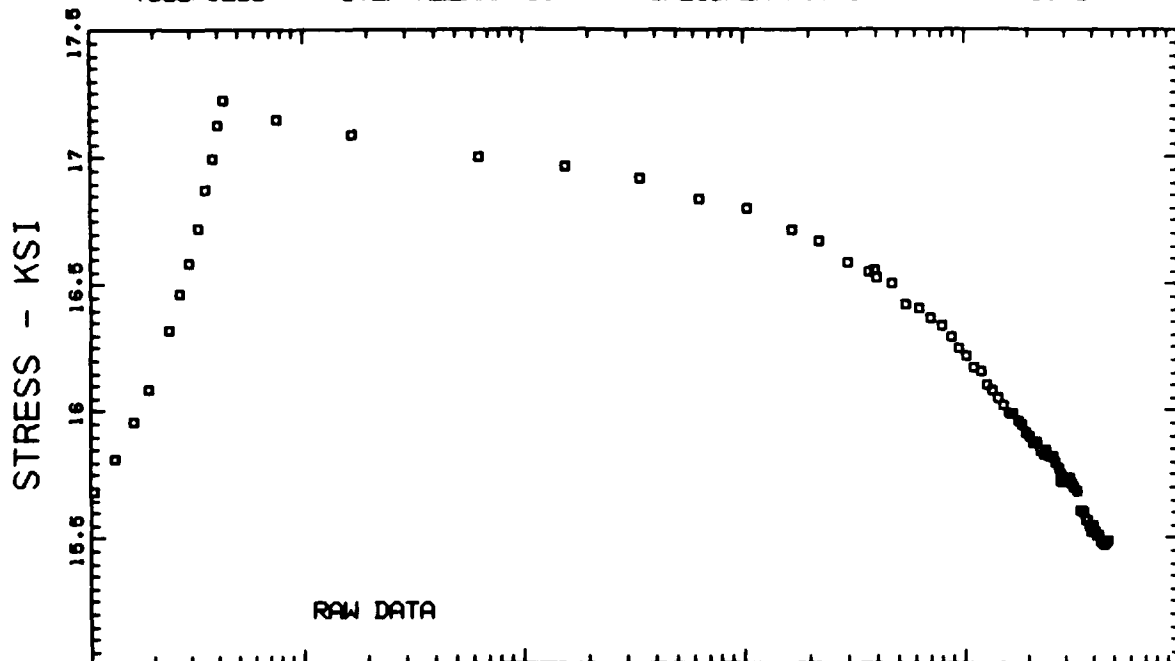

T300/5208 - STEP/RELAXATION - SPECIMEN No. 6 - STEP No. 8

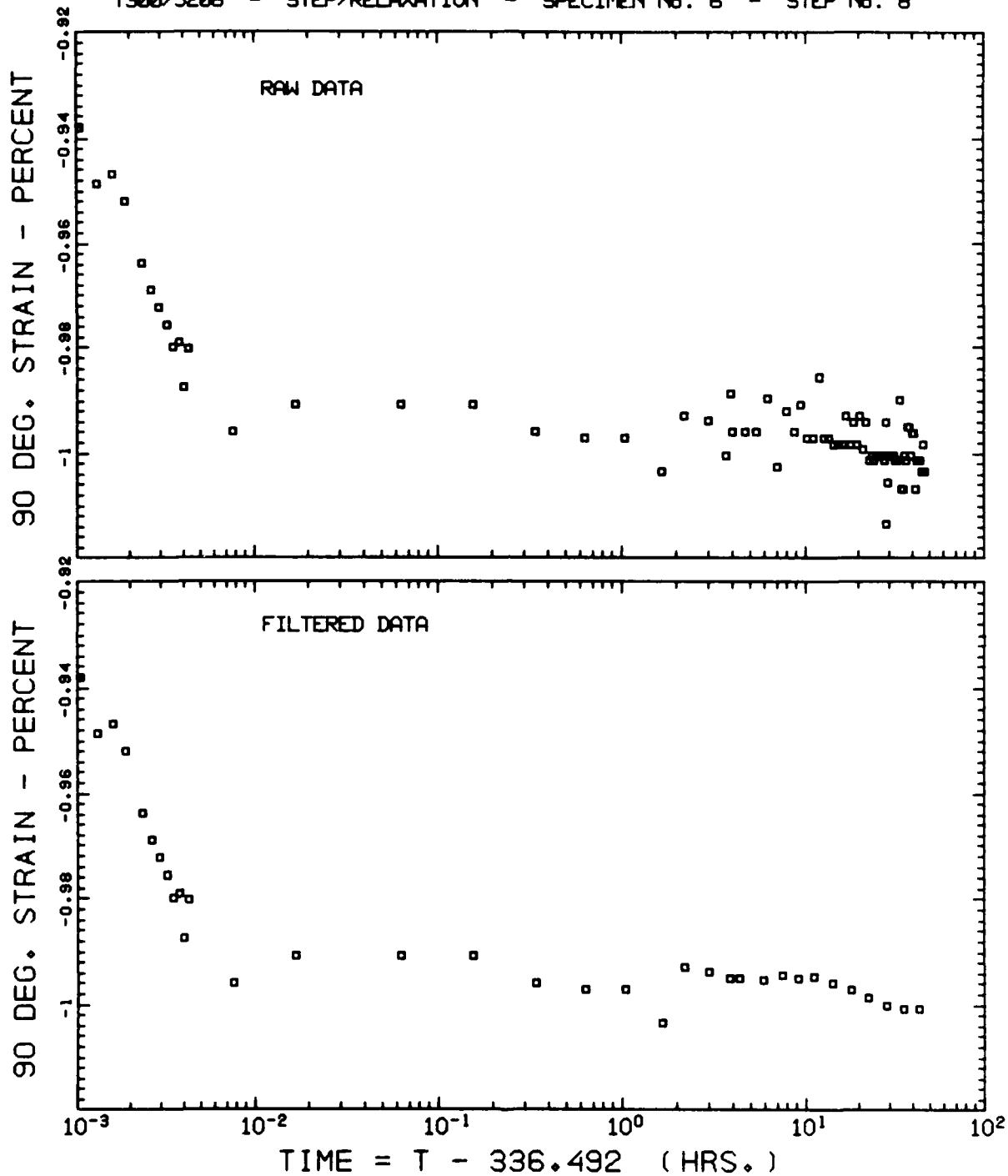

T300/5208 - STEP/RELAXATION - SPECIMEN No. 6 - STEP No. 8

45 DEG. STRAIN - PERCENT

45 DEG. STRAIN - PERCENT

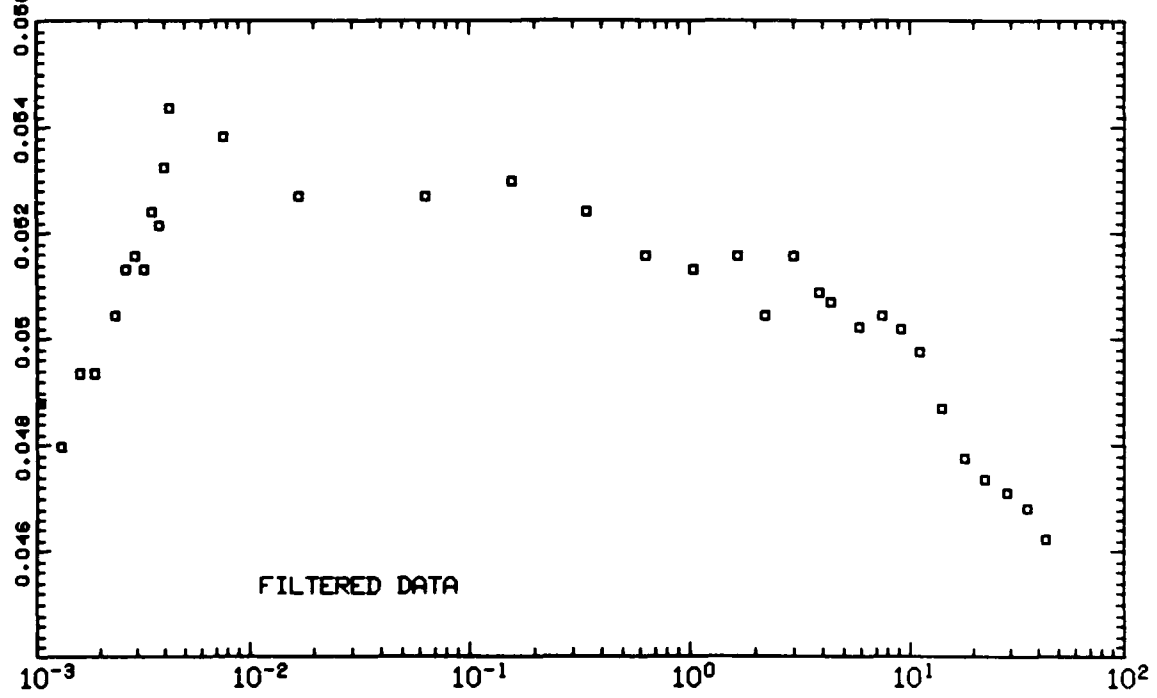
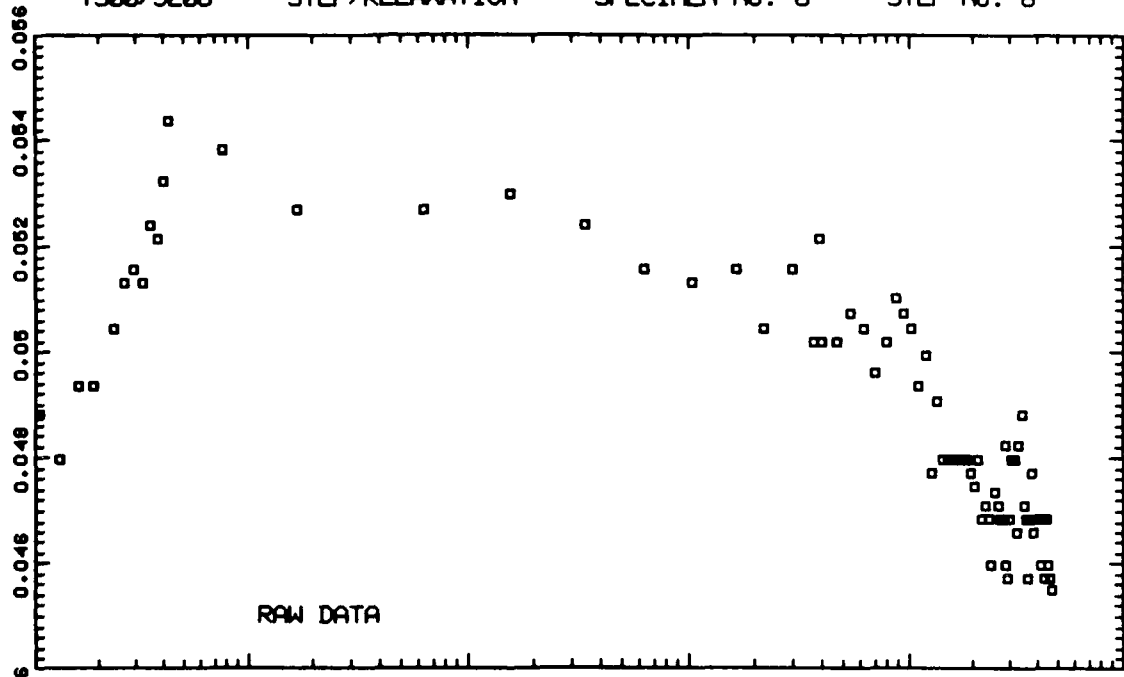

TIME = T - 336.492 (HRS.)

T300/5208 - STEP/RELAXATION - SPECIMEN No. 6 - STEP No. 9

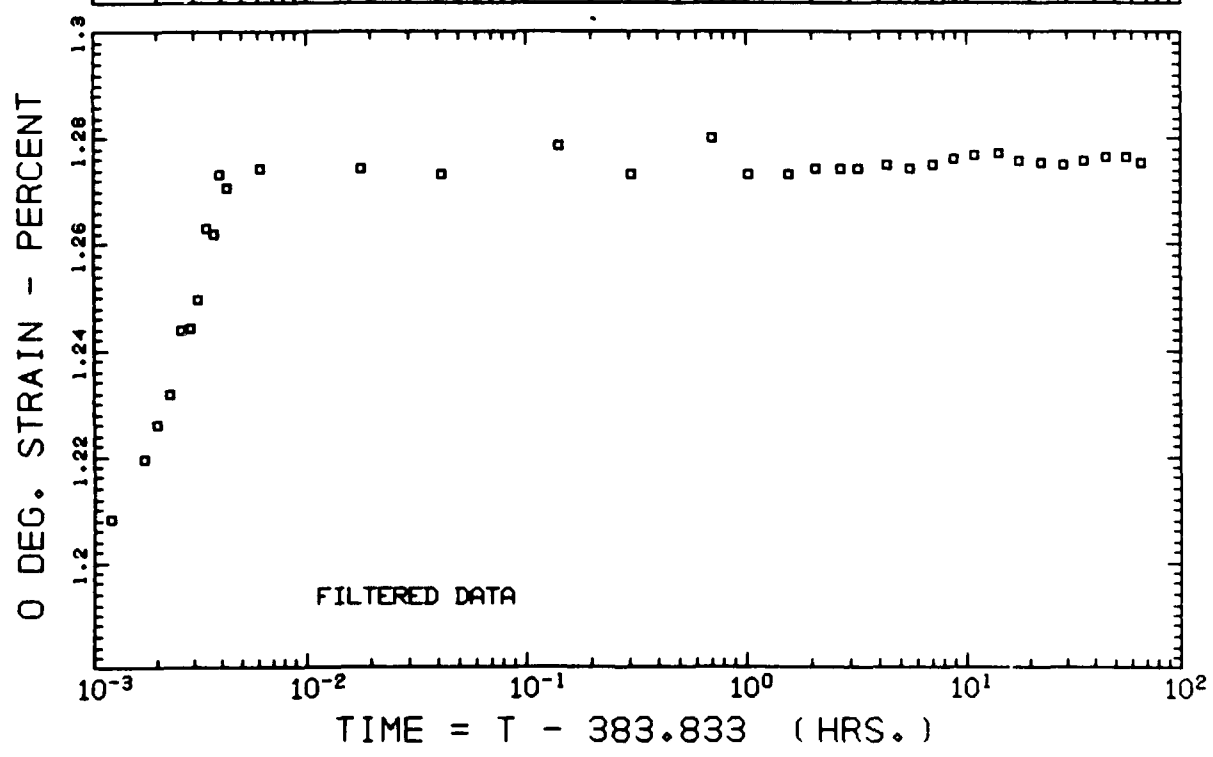
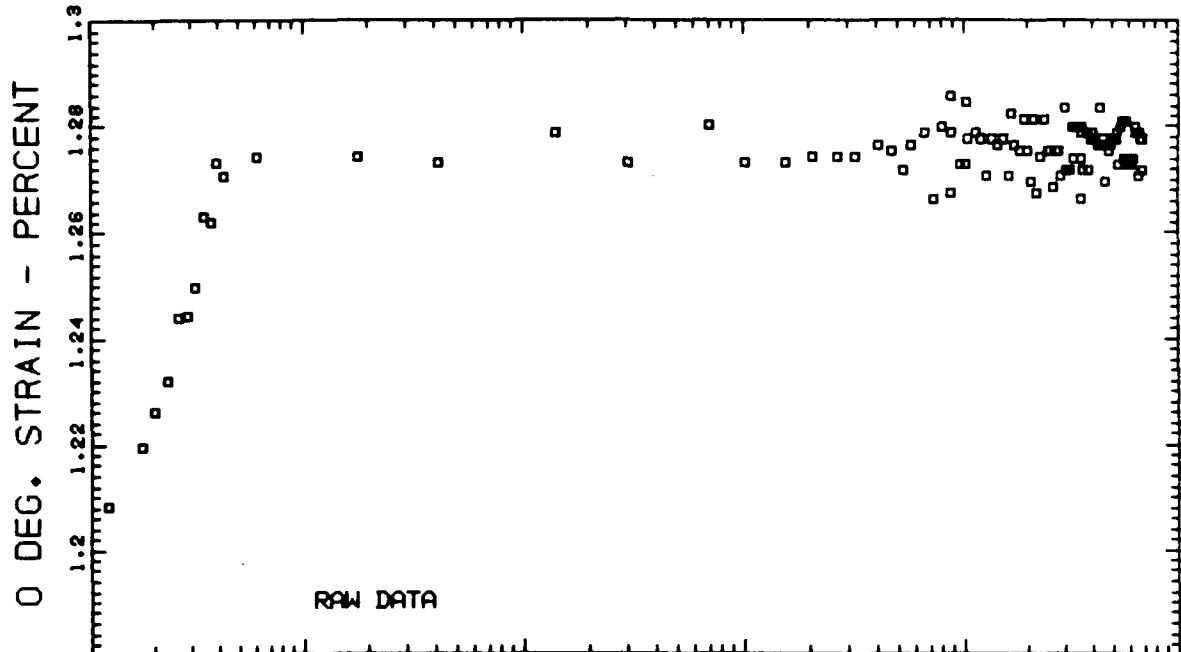



T300/5208 - STEP/RELAXATION - SPECIMEN No. 6 - STEP No. 9

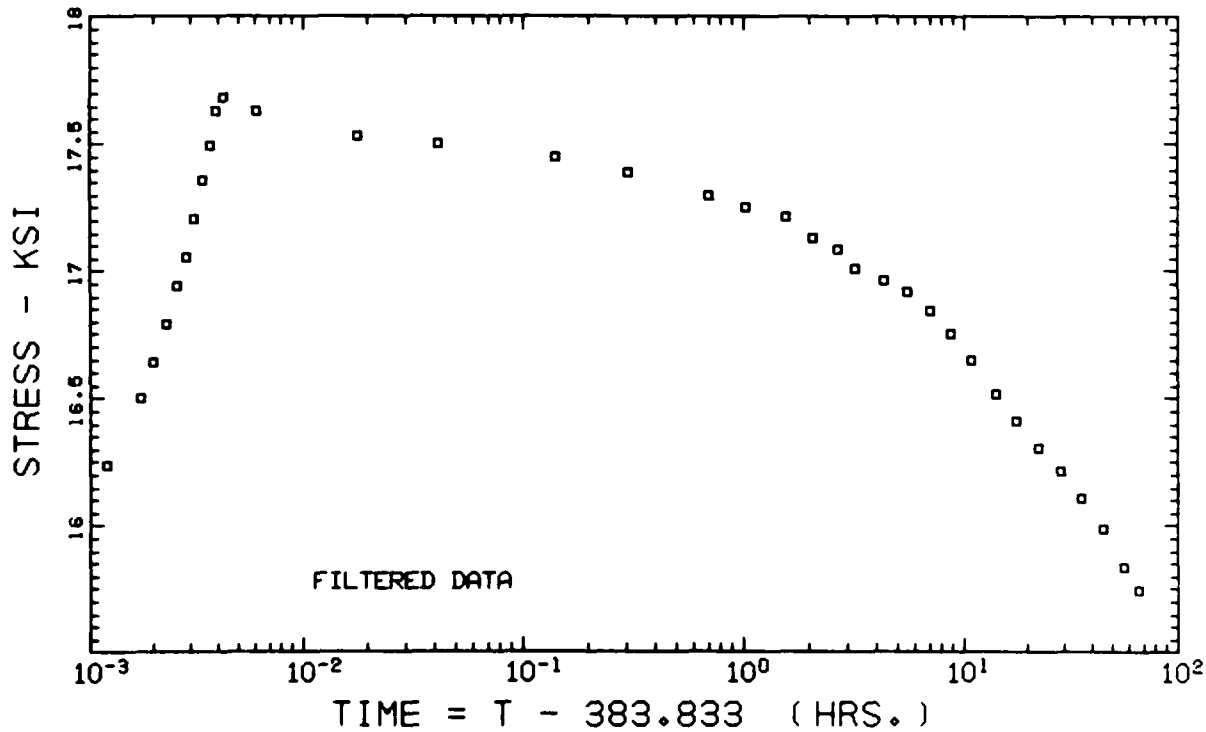
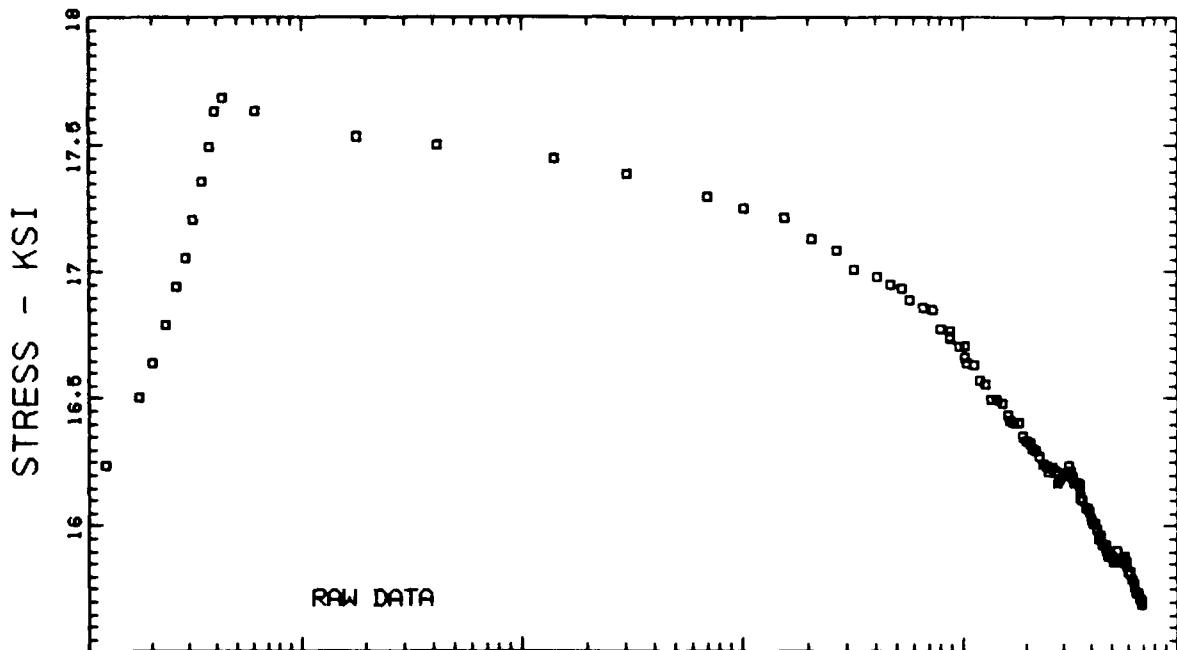

T300/5208 - STEP/RELAXATION - SPECIMEN No. 6 - STEP No. 9

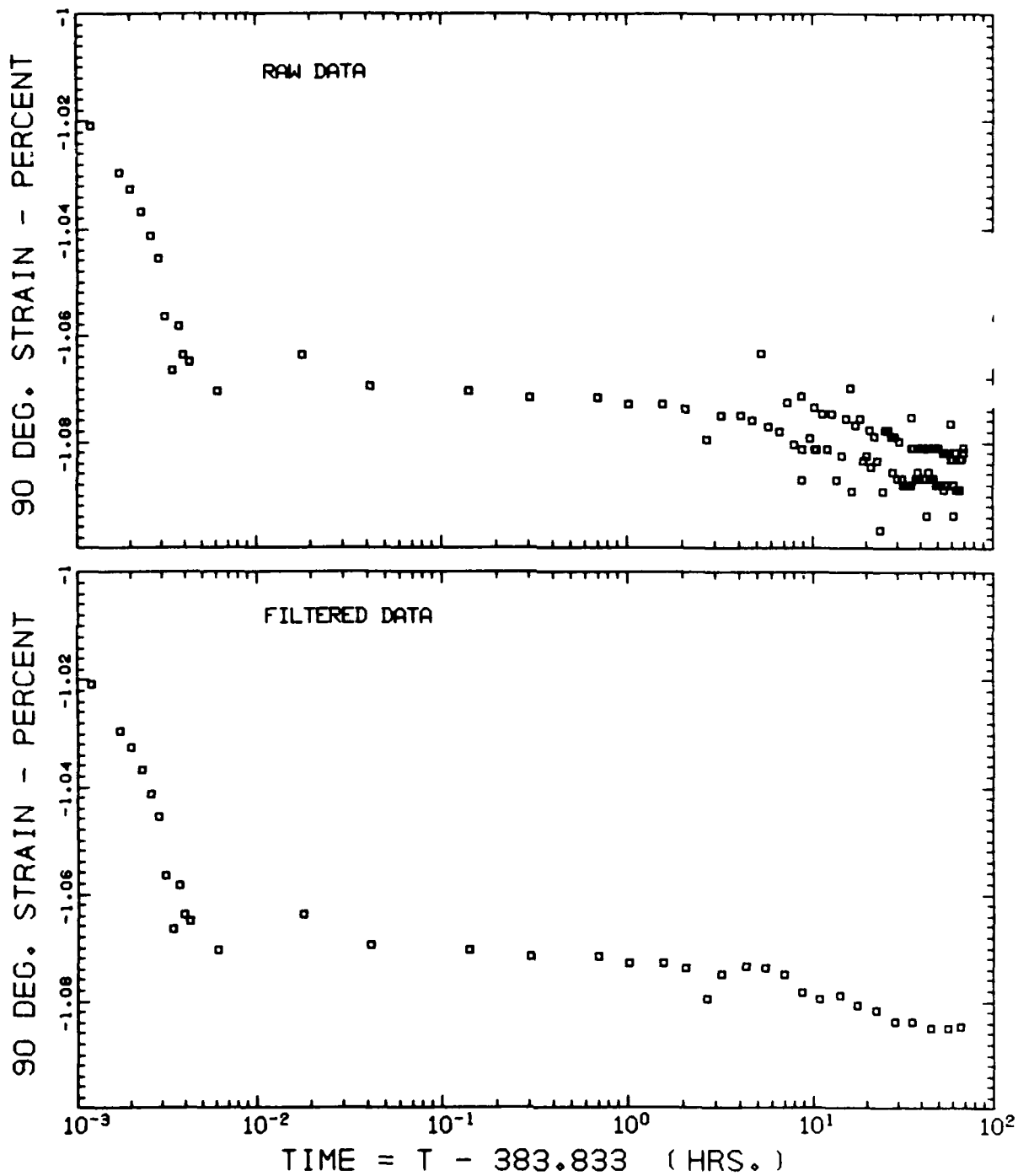

T300/5208 - STFP/RELAXATION - SPECIMEN No. 6 - STEP No. 9

45 DEG. STRAIN - PERCENT

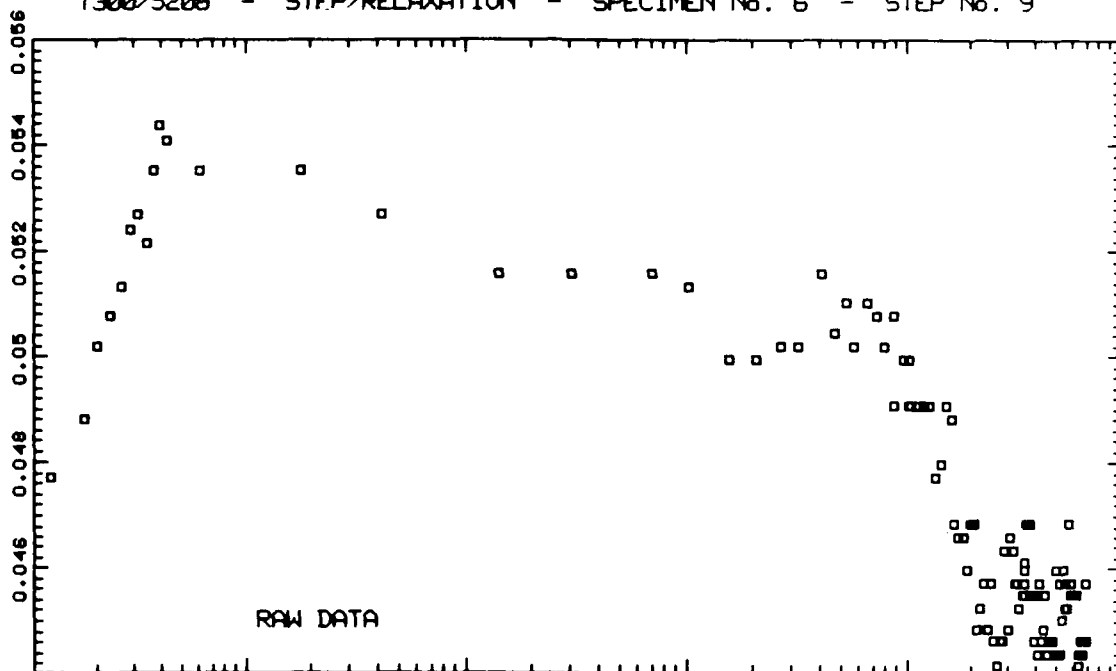

45 DEG. STRAIN - PERCENT

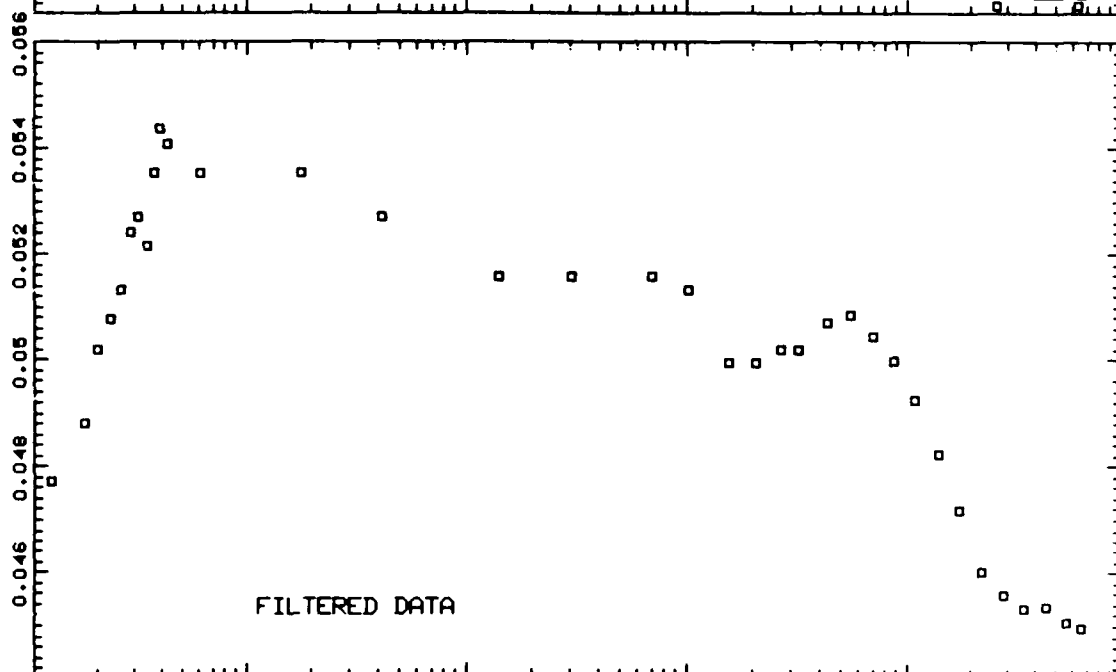

TIME = T - 383.833 (HRS.)

T300/S208 - STEP/RELAXATION - SPECIMEN No. 6 - STEP No. 10

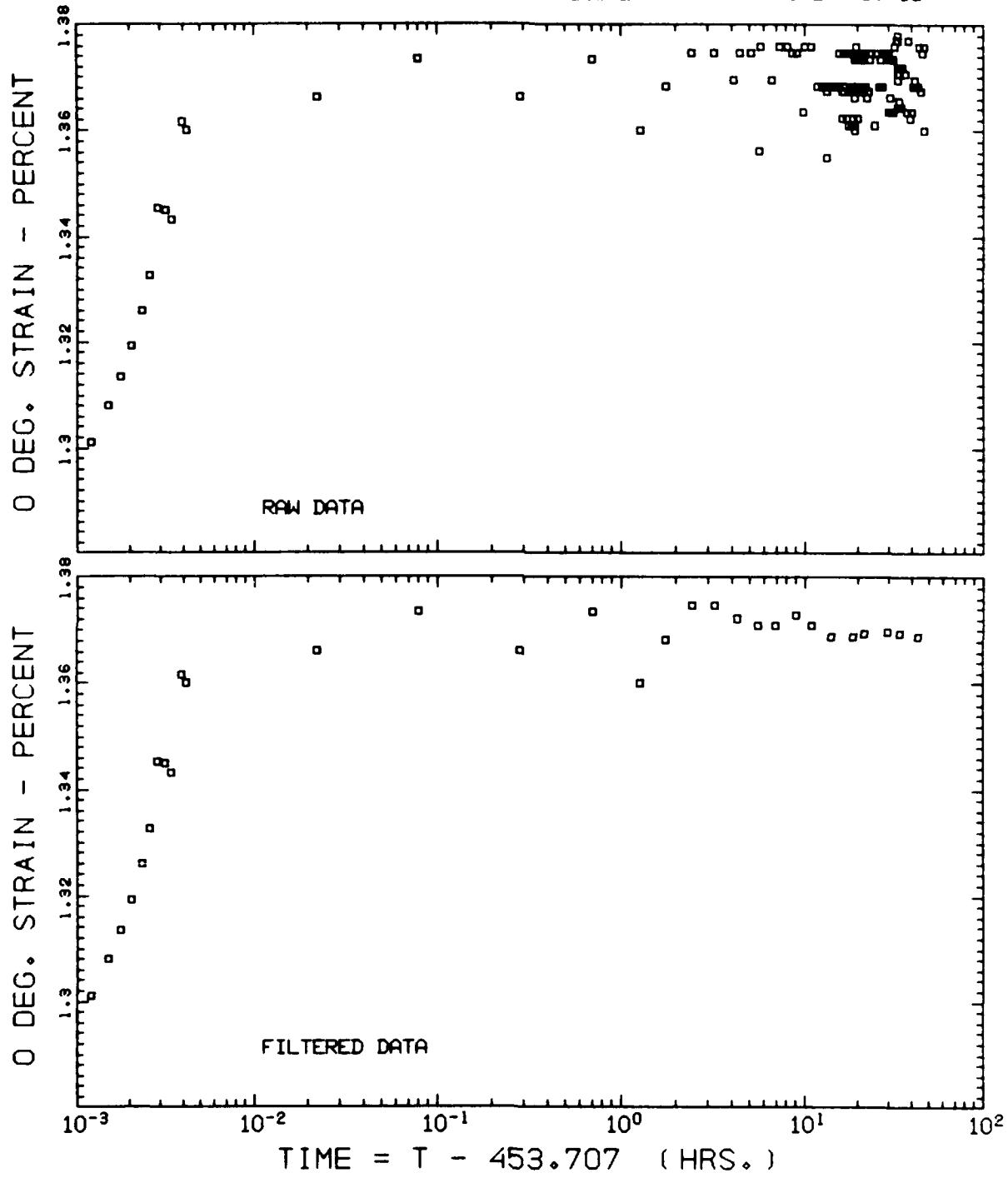

T300/5208 - STEP/RELAXATION - SPECIMEN No. 6 - STEP No. 10

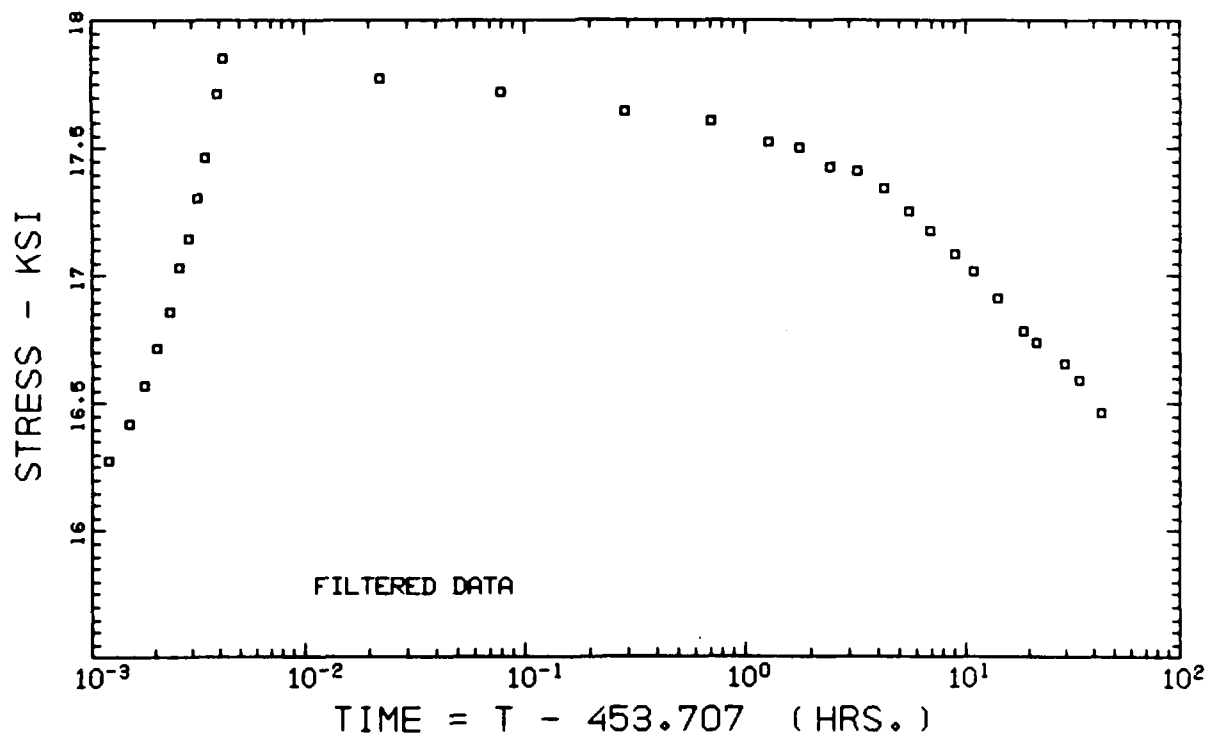
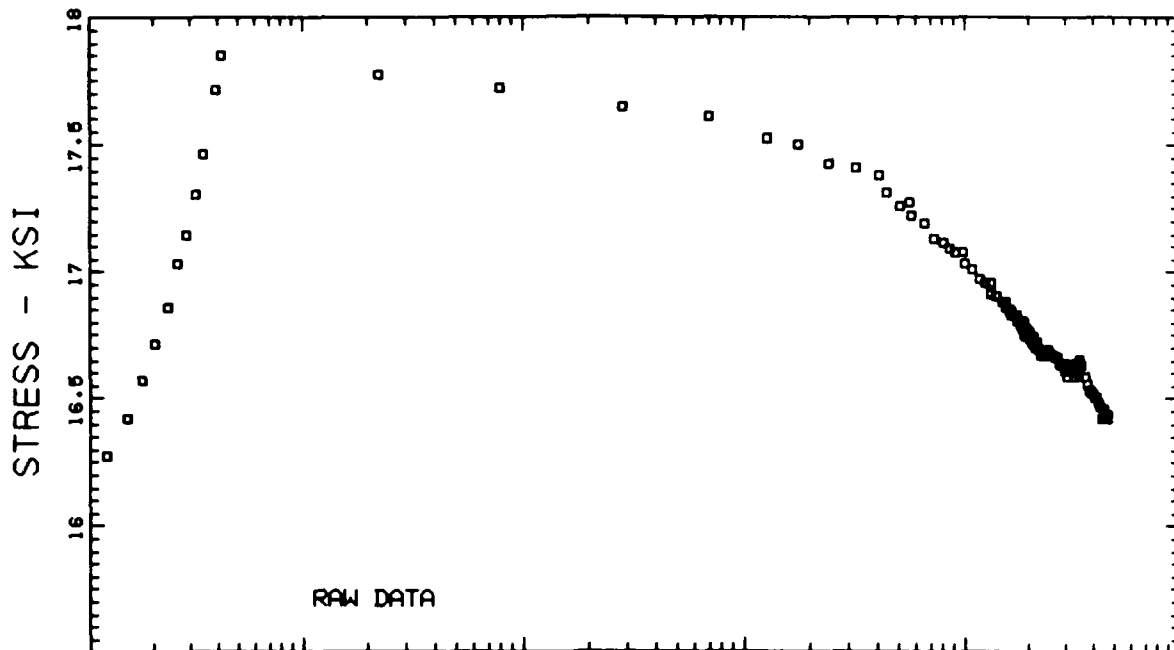

TIME = T - 453.707 (HRS.)

T300/5208 - STEP/RELAXATION - SPECIMEN No. 6 - STEP No. 10

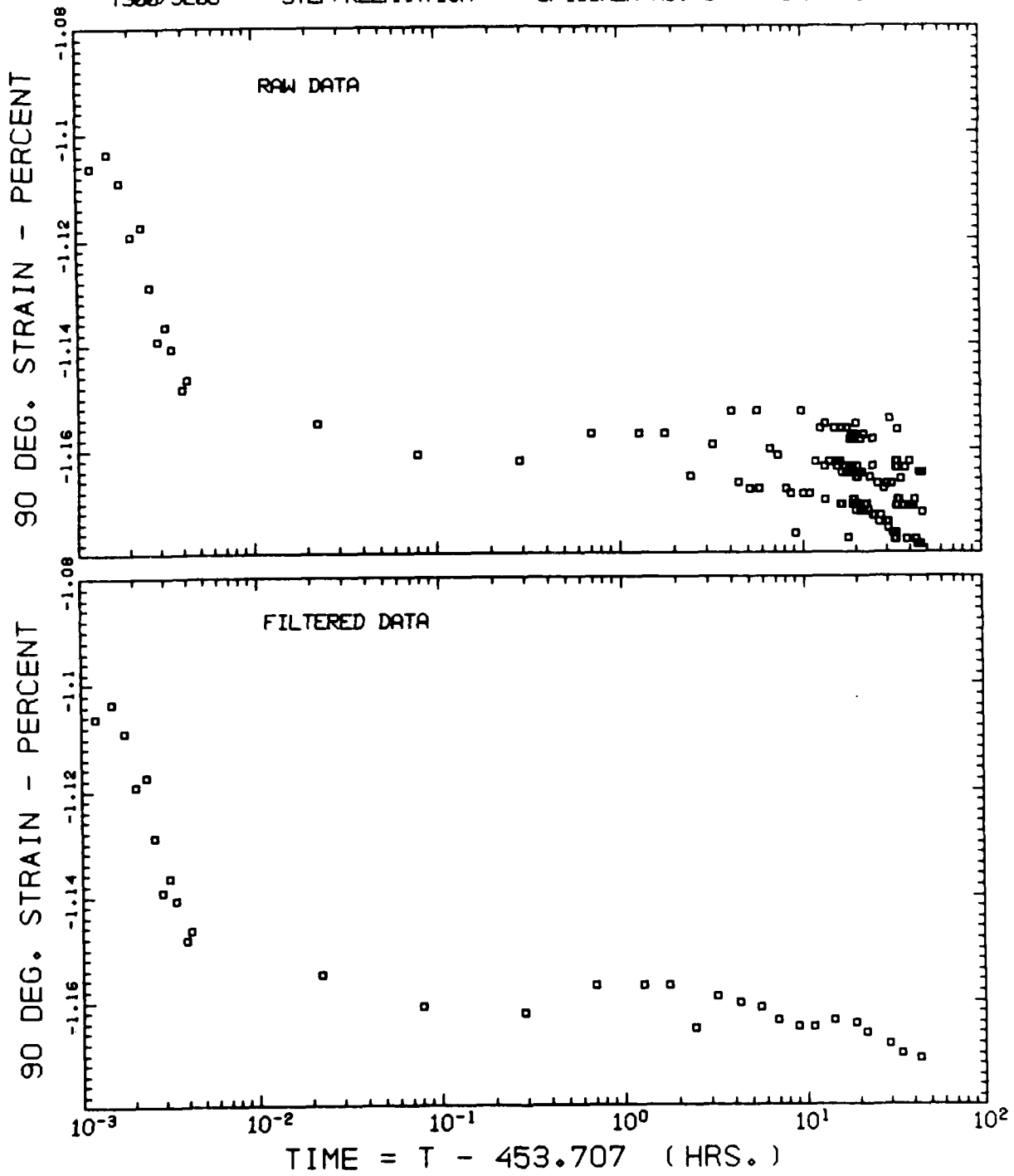

T300/5208 - STEP/RELAXATION - SPECIMEN No. 6 - STEP No. 10

45 DEG. STRAIN - PERCENT

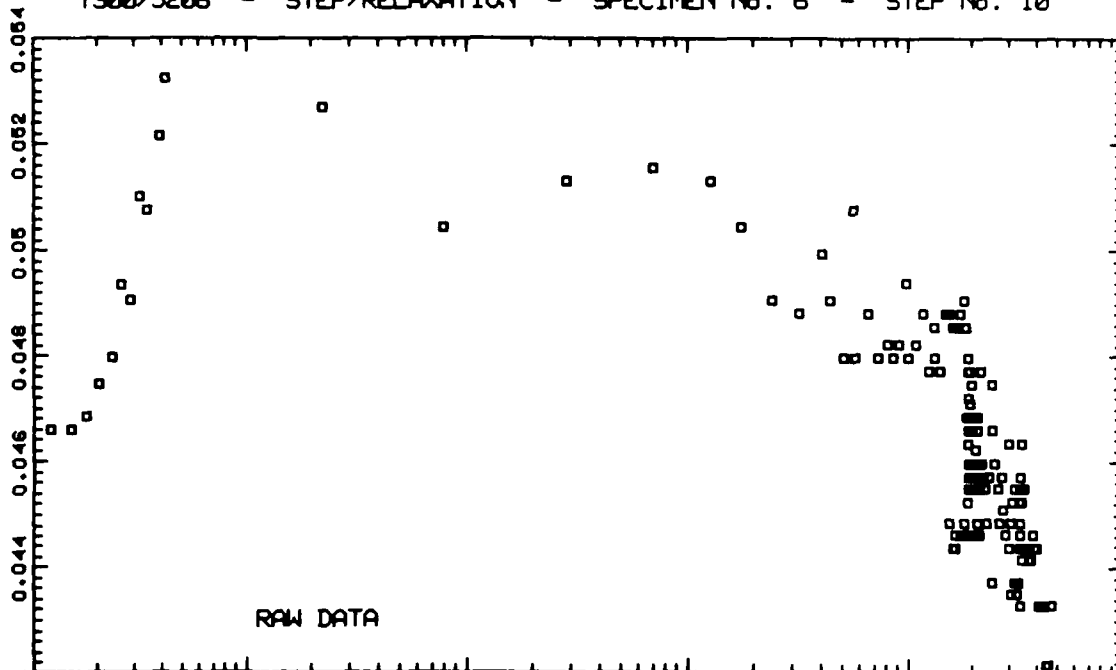

45 DEG. STRAIN - PERCENT

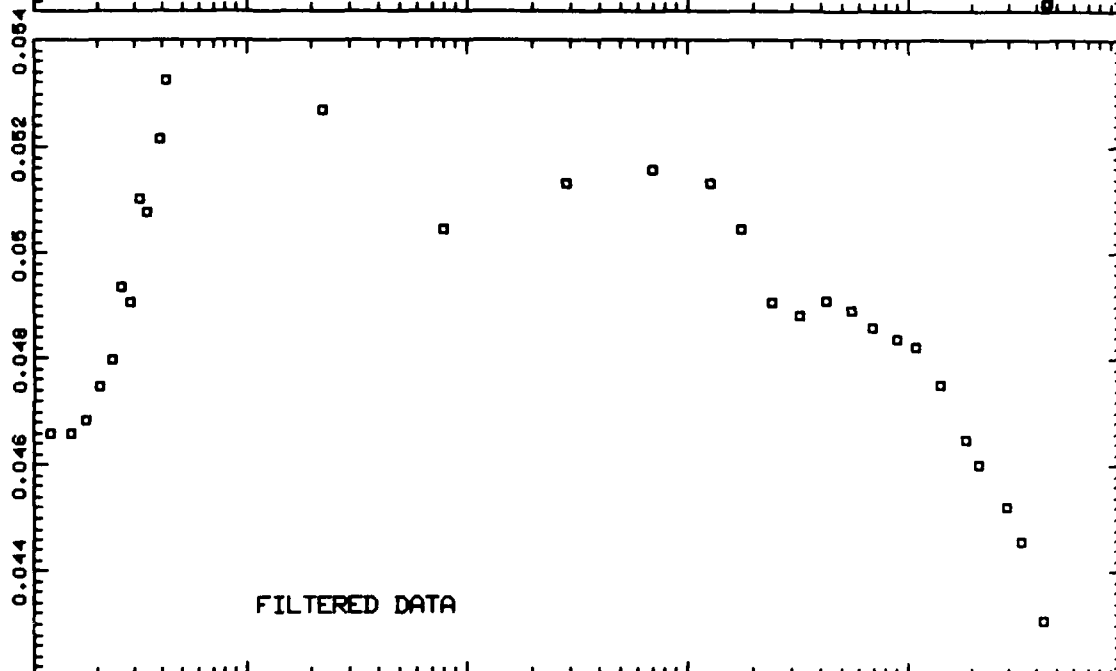

TIME = T - 453.707 (HRS.)

T300/S208 - STEP/RELAXATION - SPECIMEN No. 6 - STEP No. 11

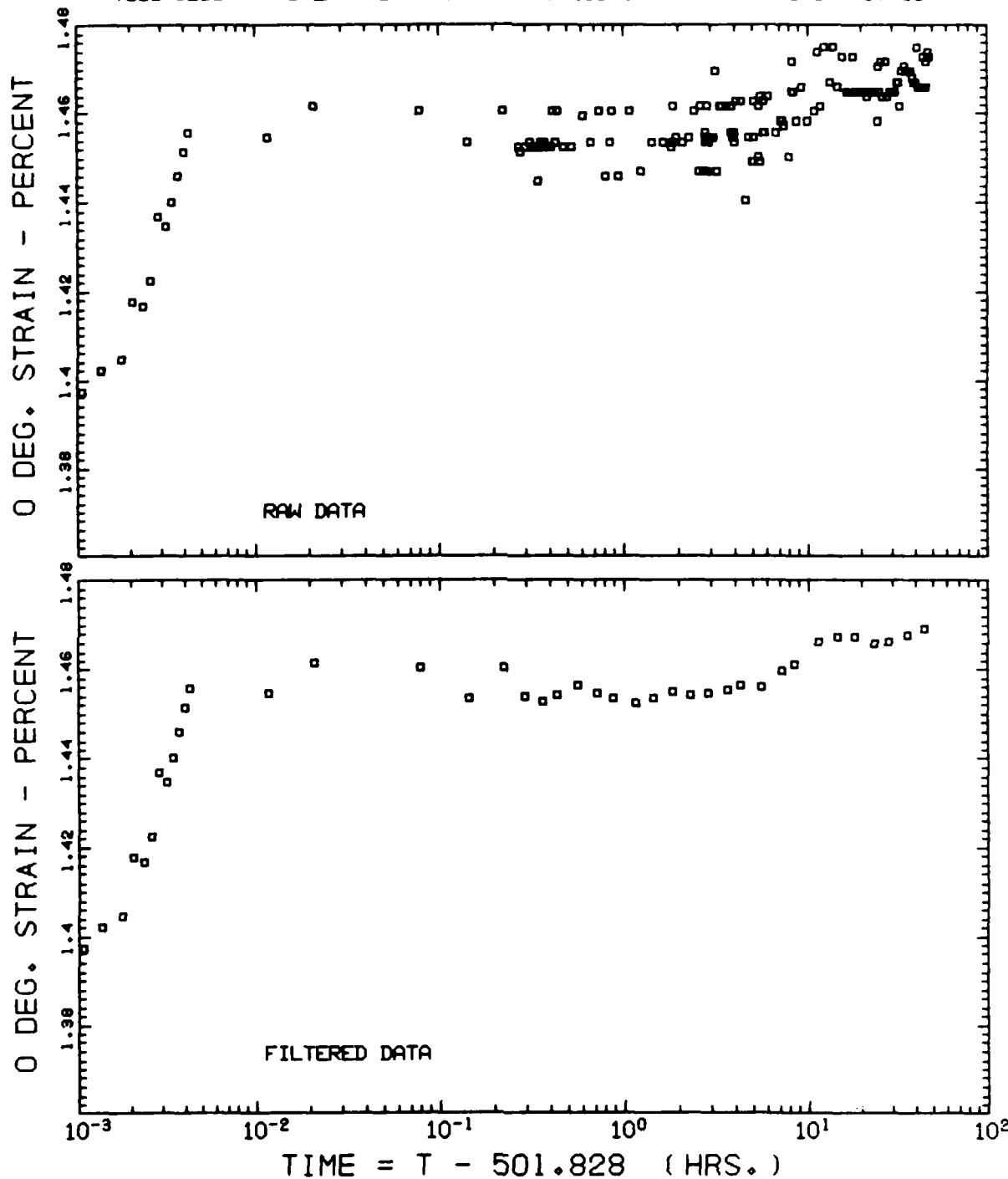



T300/5208 - STEP/RELAXATION - SPECIMEN No. 6 - STEP No. 11

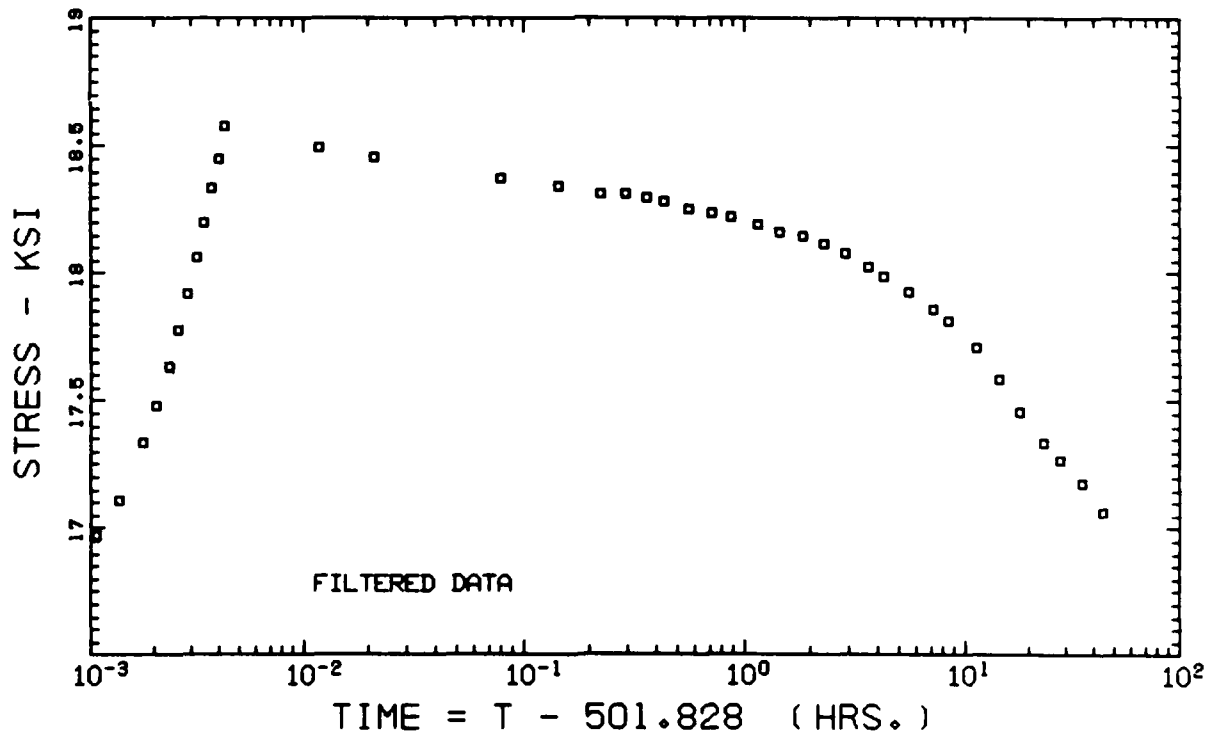
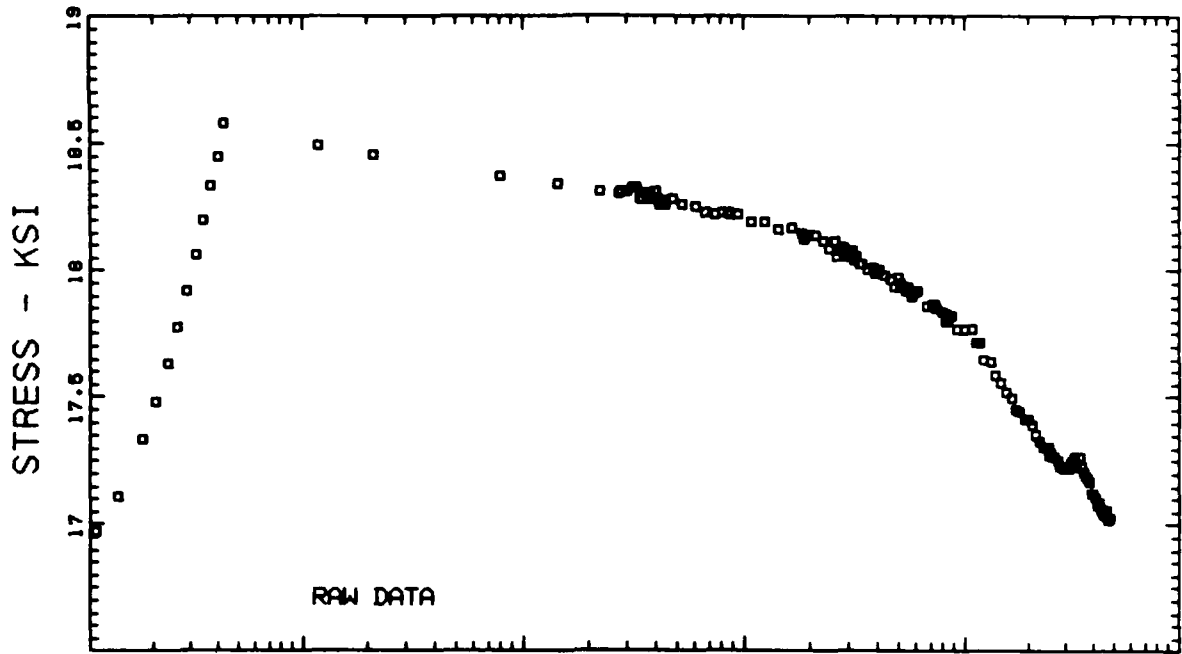

T300/5208 - STEP/RELAXATION - SPECIMEN No. 6 - STEP No. 11

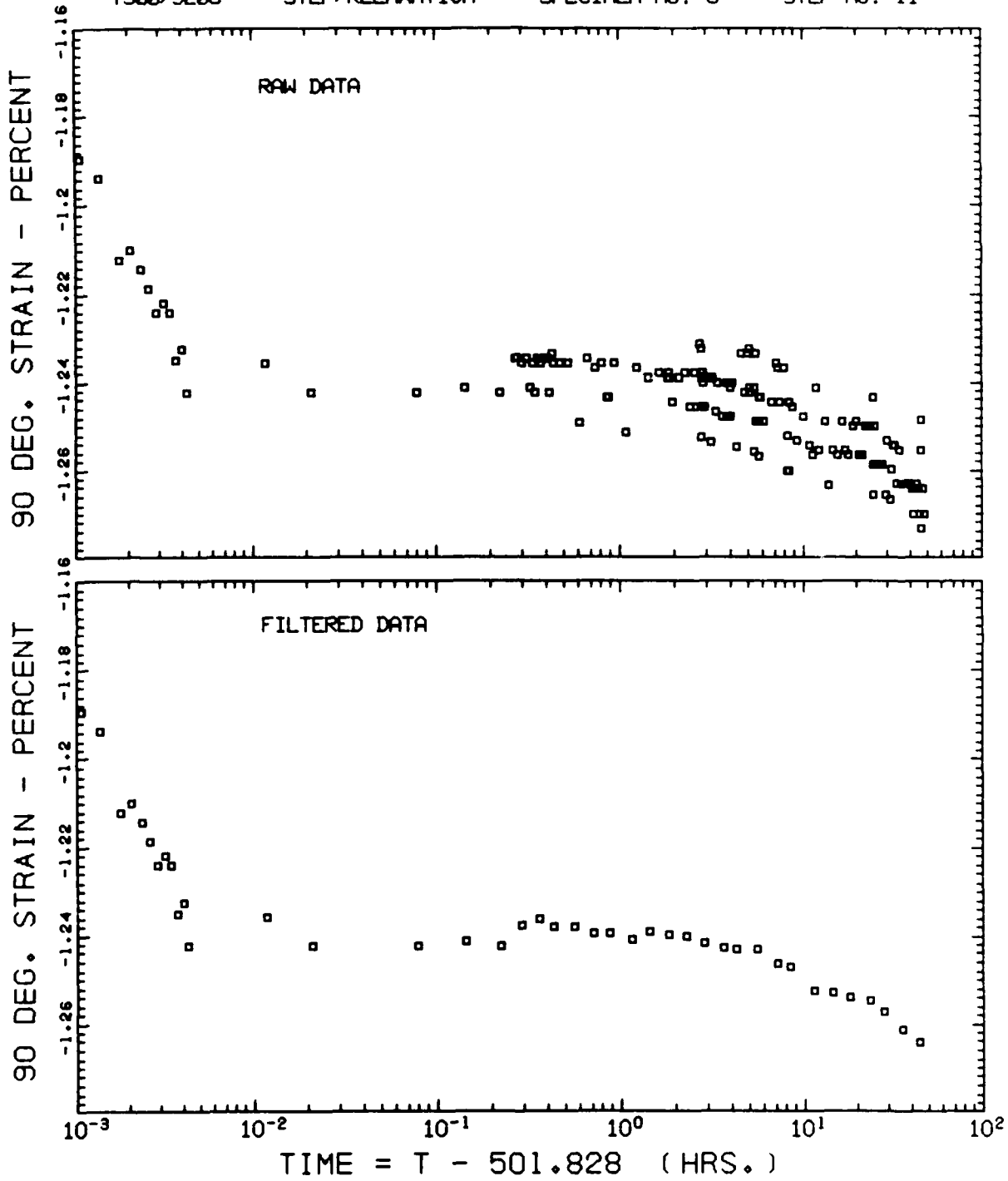

T300/5208 - STEP/RELAXATION - SPECIMEN No. 6 - STEP No. 11

45 DEG. STRAIN - PERCENT

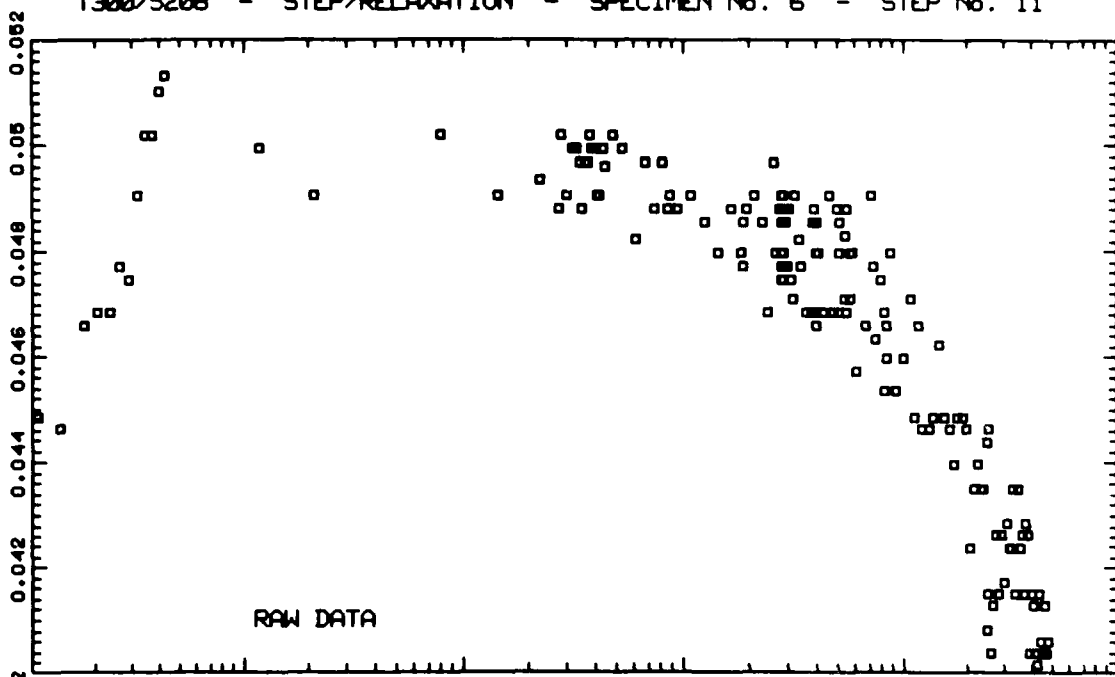

45 DEG. STRAIN - PERCENT

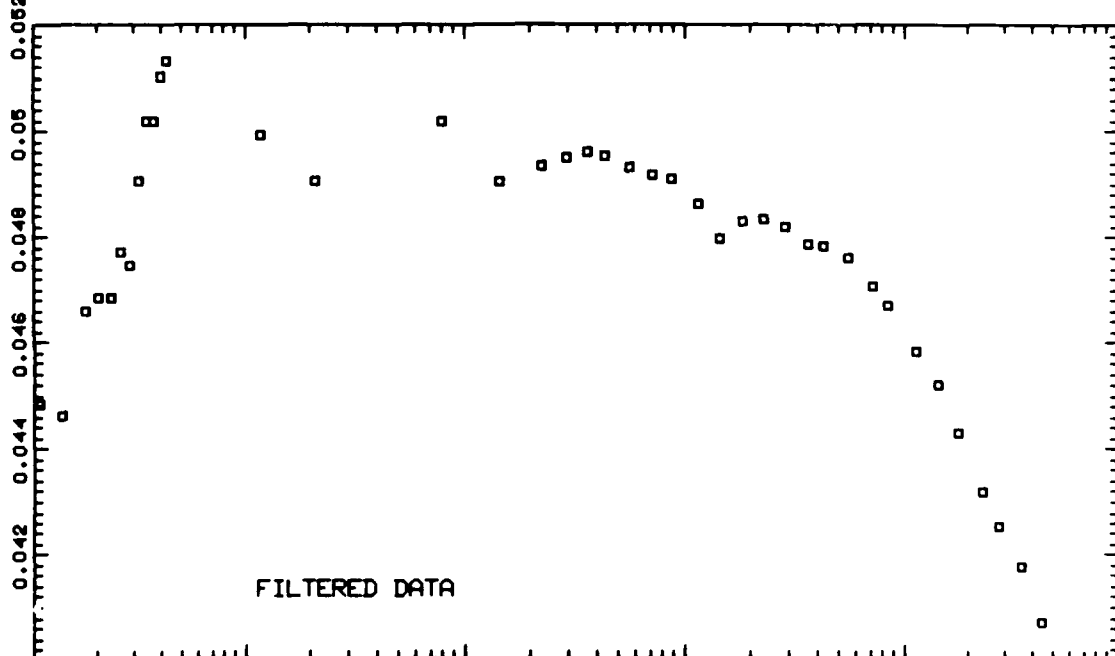

TIME = T - 501.828 (HRS.)

T300/S208 - STEP/RELAXATION - SPECIMEN No. 6 - STEP No. 12

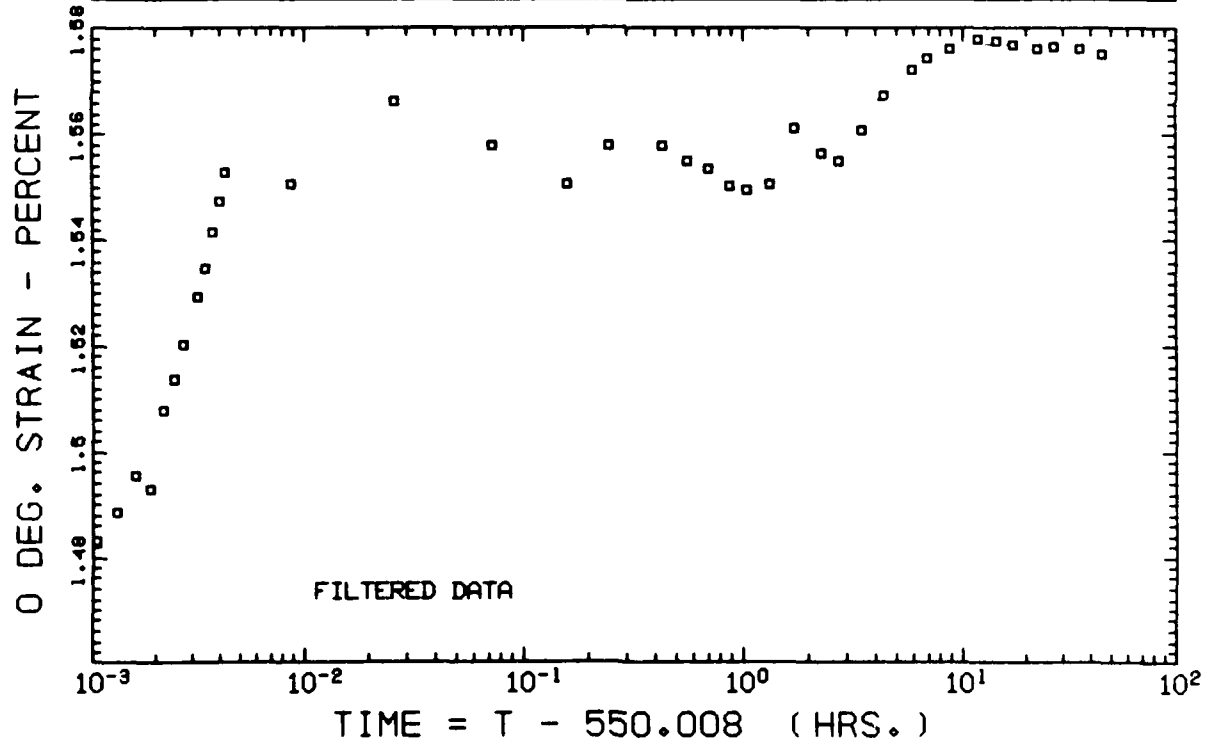
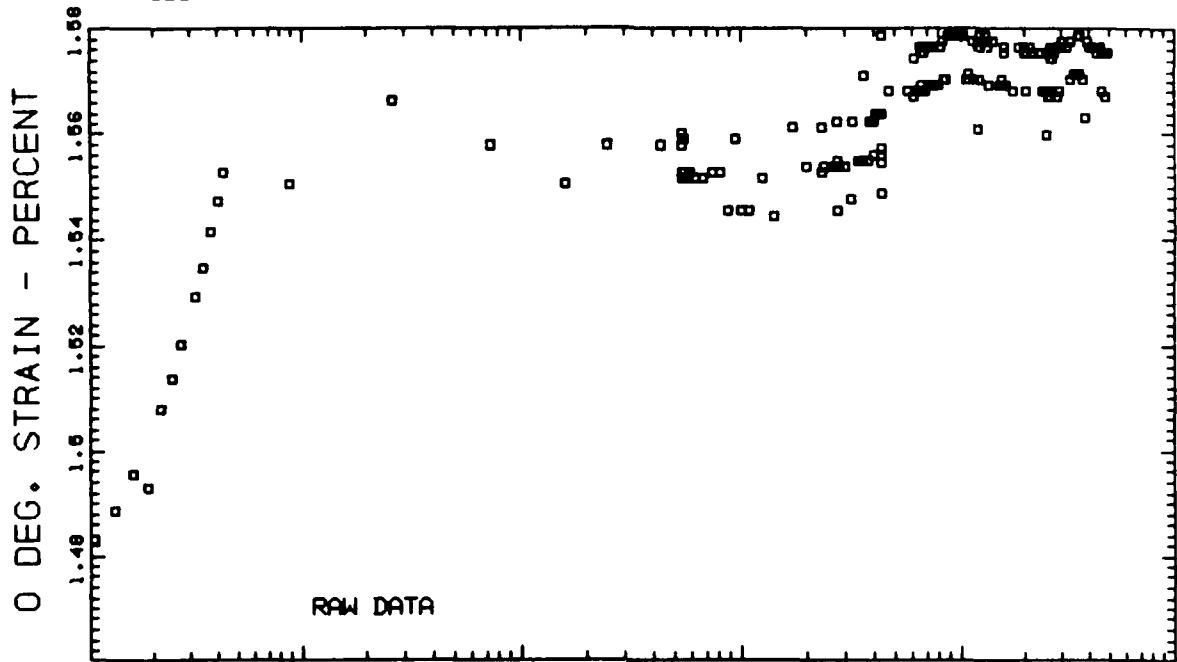

T300/S208 - STEP/RELAXATION - SPECIMEN No. 6 - STEP No. 12

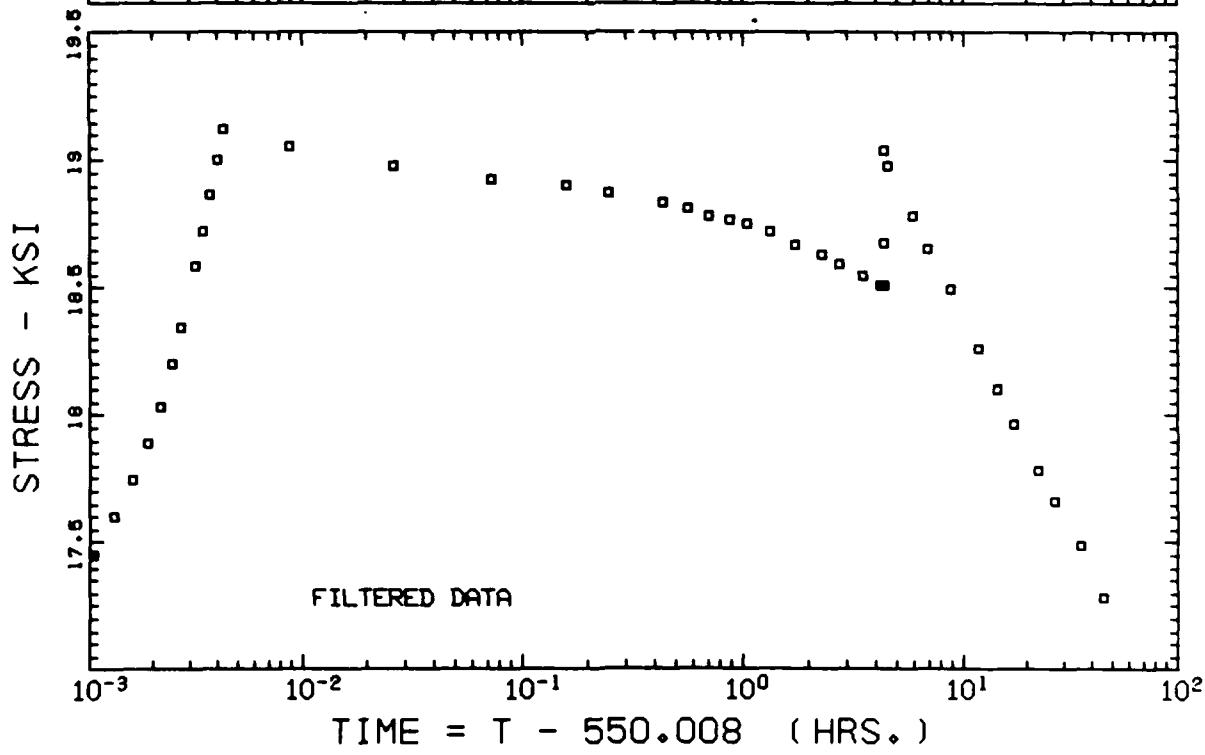
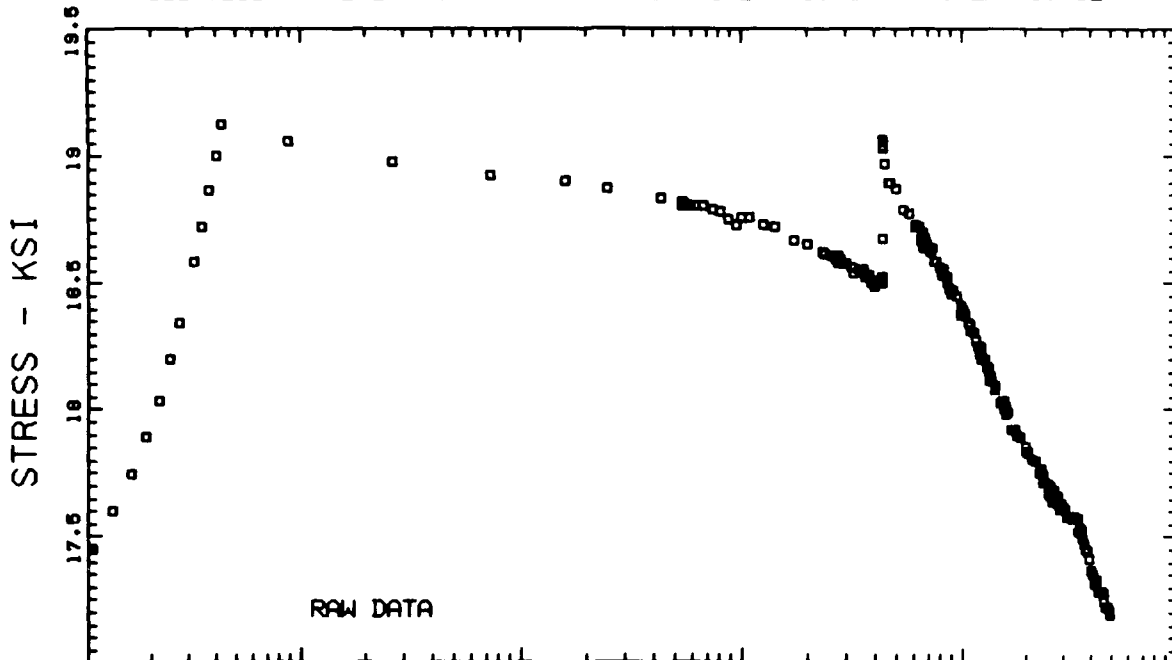

T300/5208 - STEP/RELAXATION - SPECIMEN No. 6 - STEP No. 12

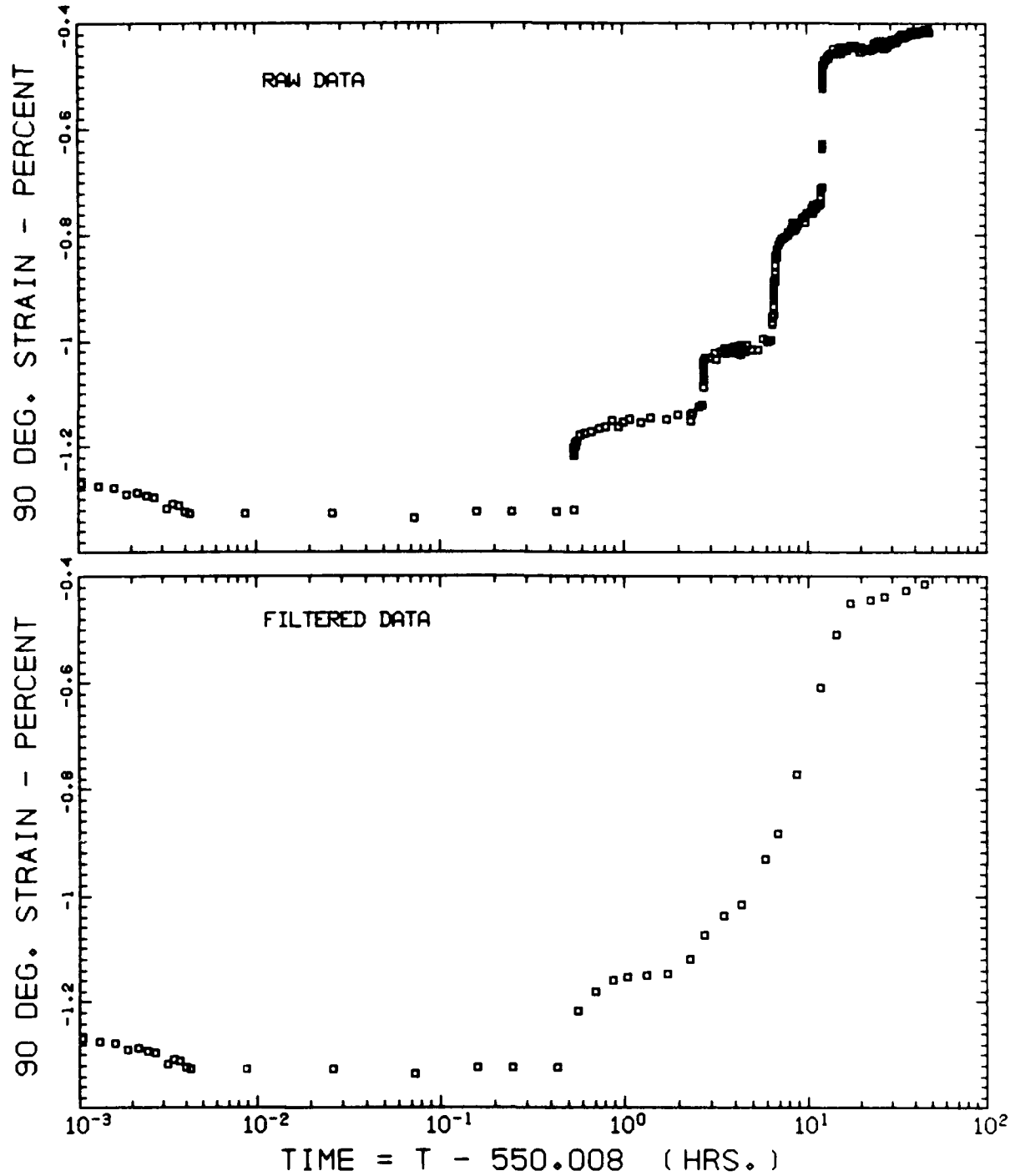

T300/5208 - STEP/RELAXATION - SPECIMEN No. 6 - STEP No. 12

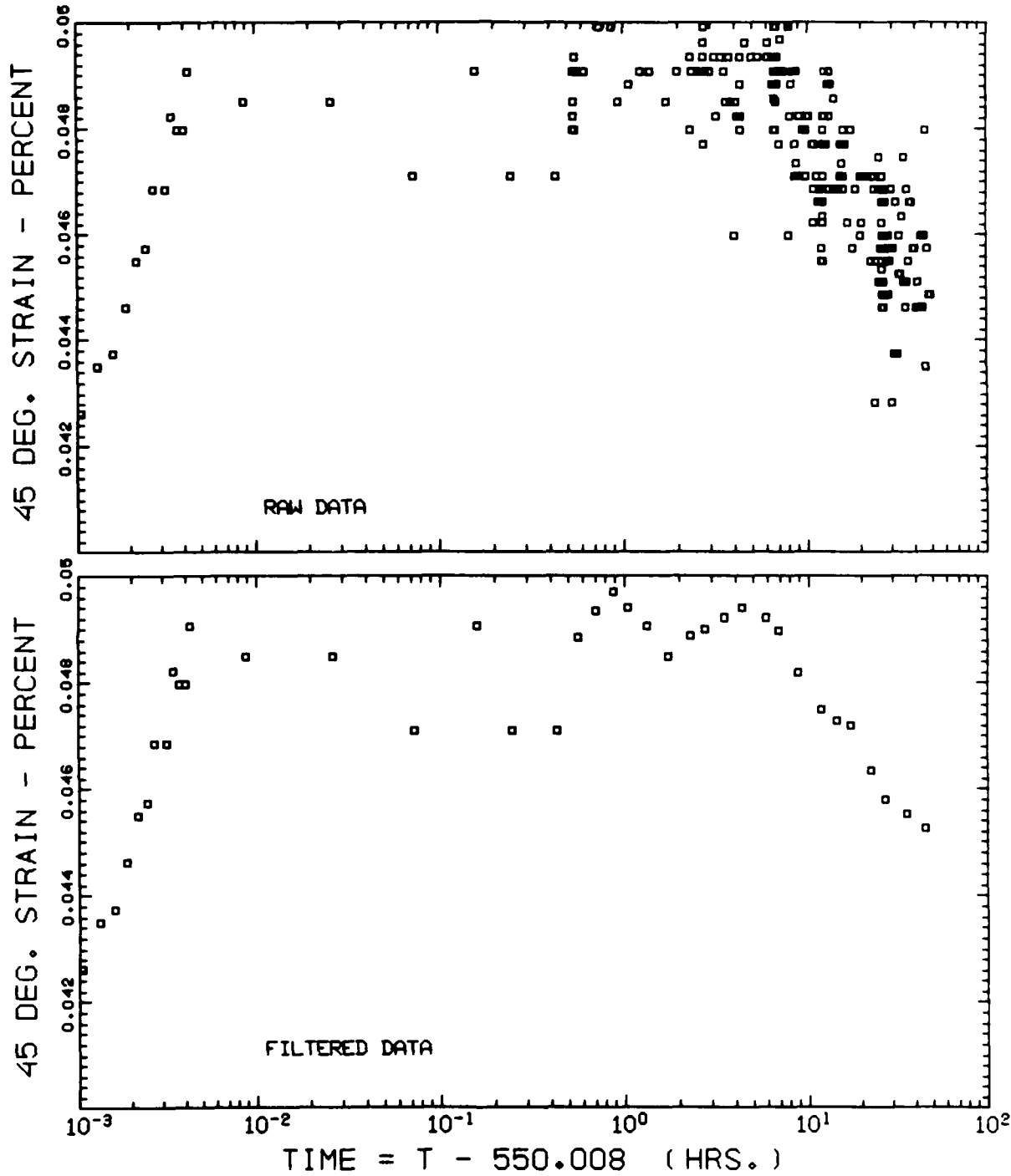

T300/5208 - STEP/RELAXATION - SPECIMEN NO. 7

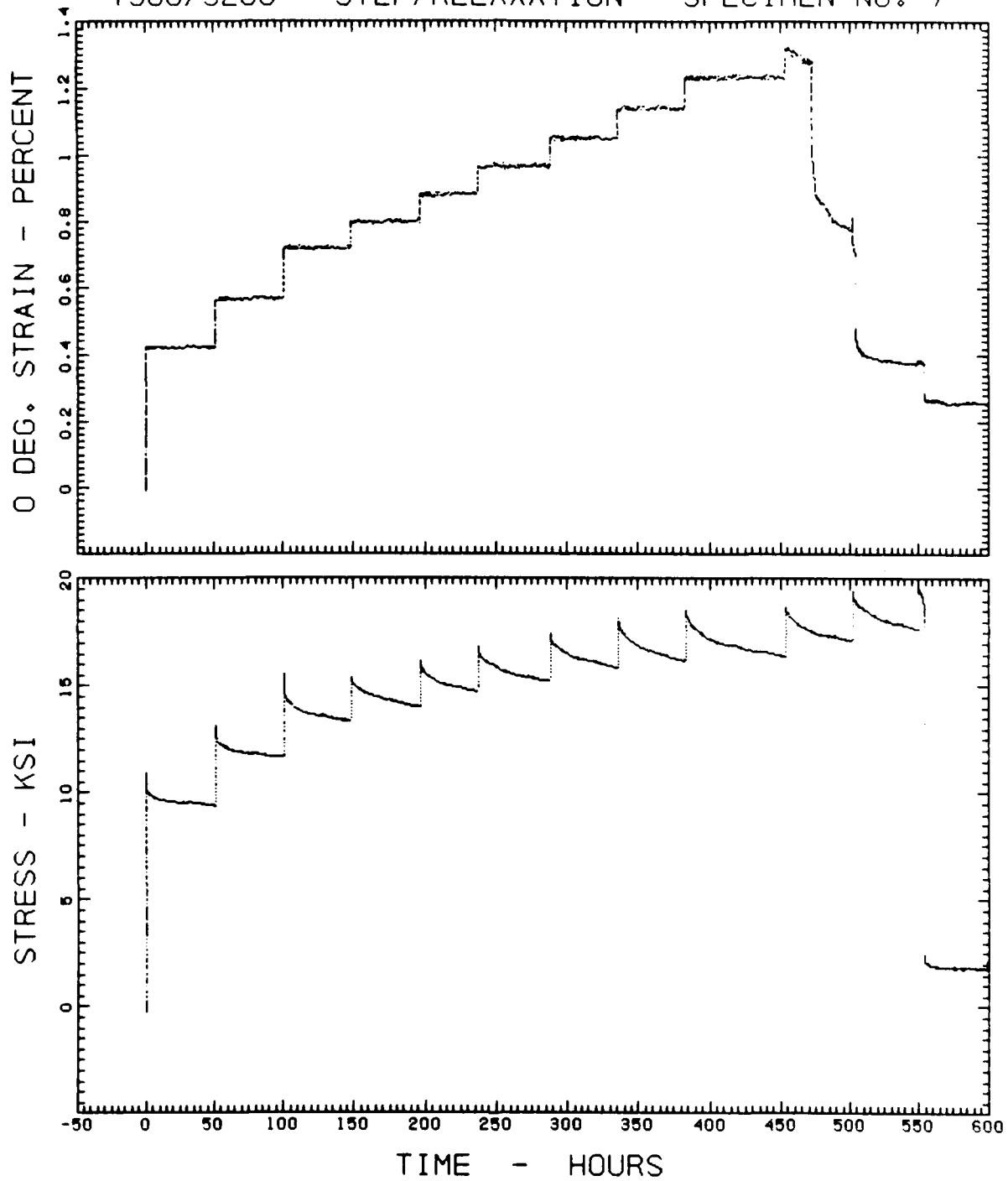



T300/5208 - STEP/RELAXATION - SPECIMEN NO. 7

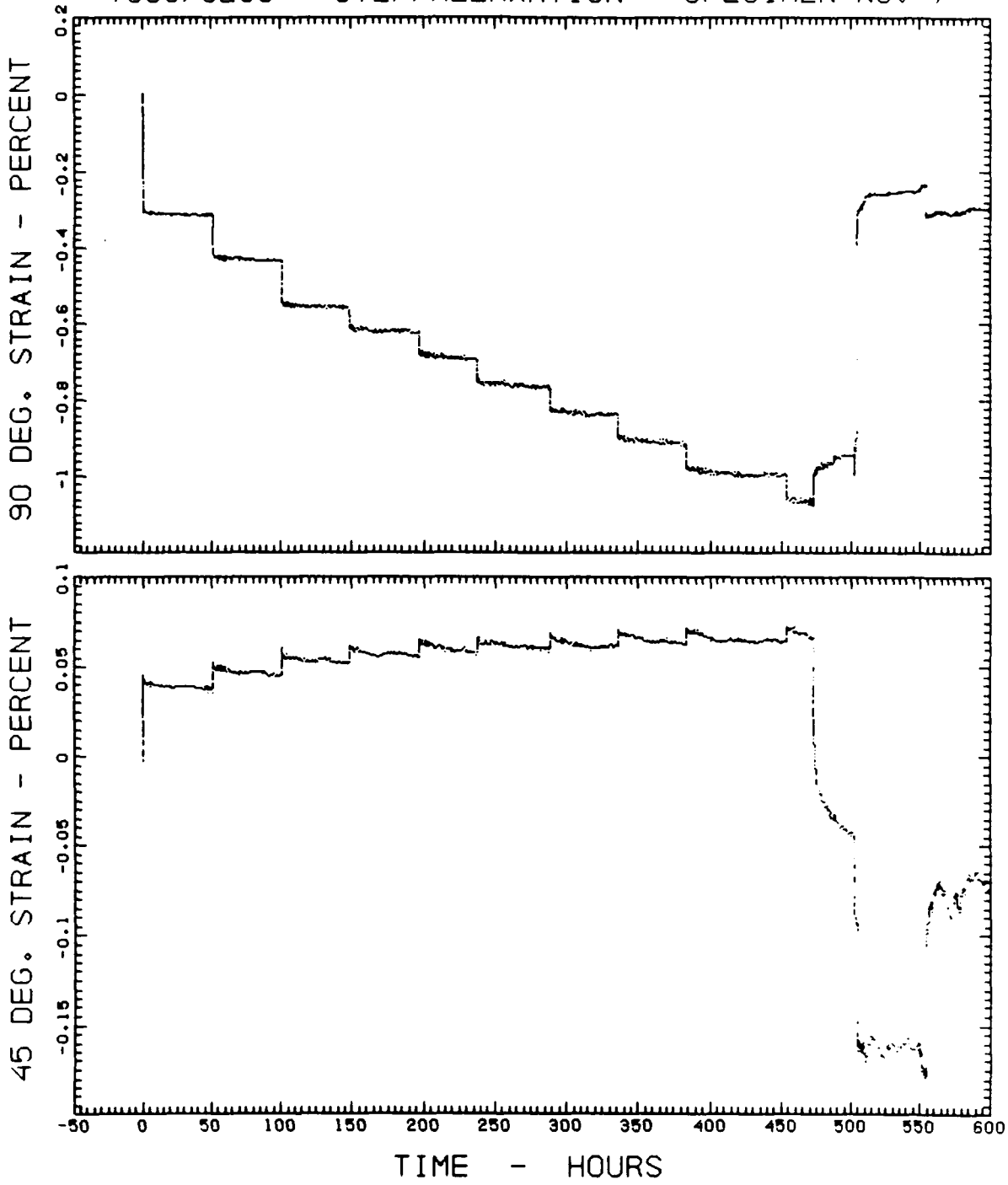

T300/5208 - STEP/RELAXATION - SPECIMEN No. 7 - STEP No. 1

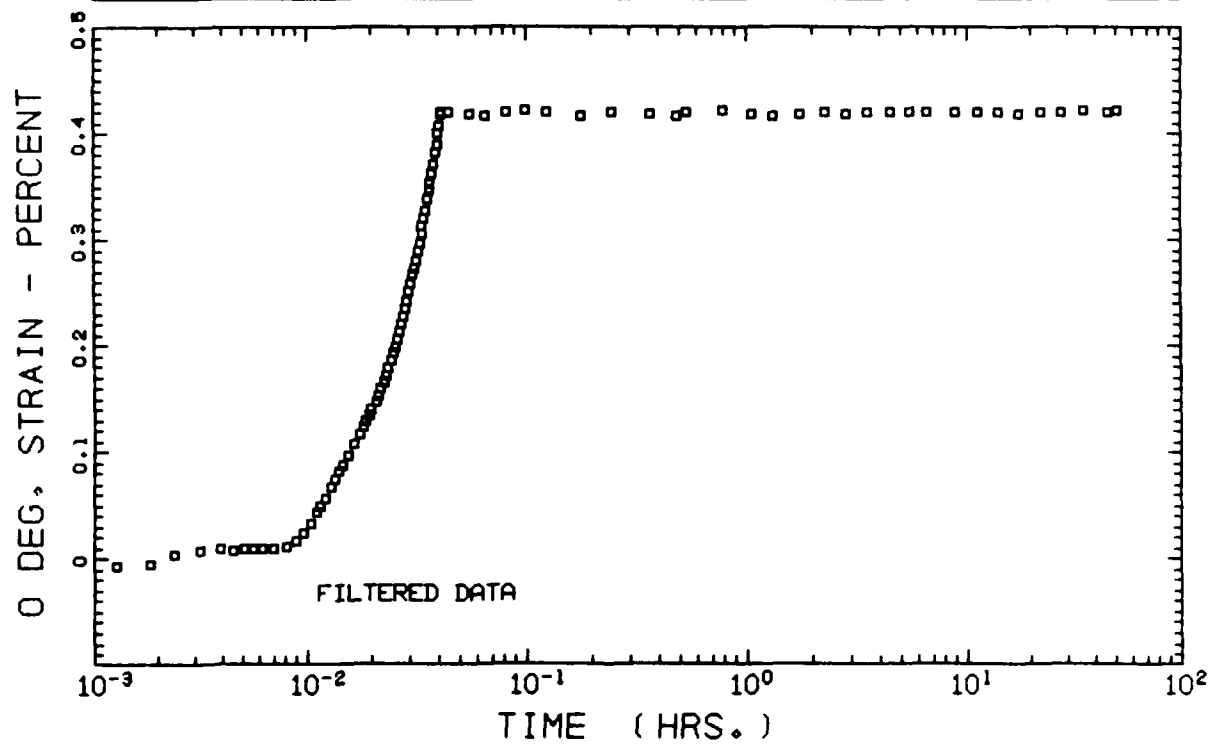
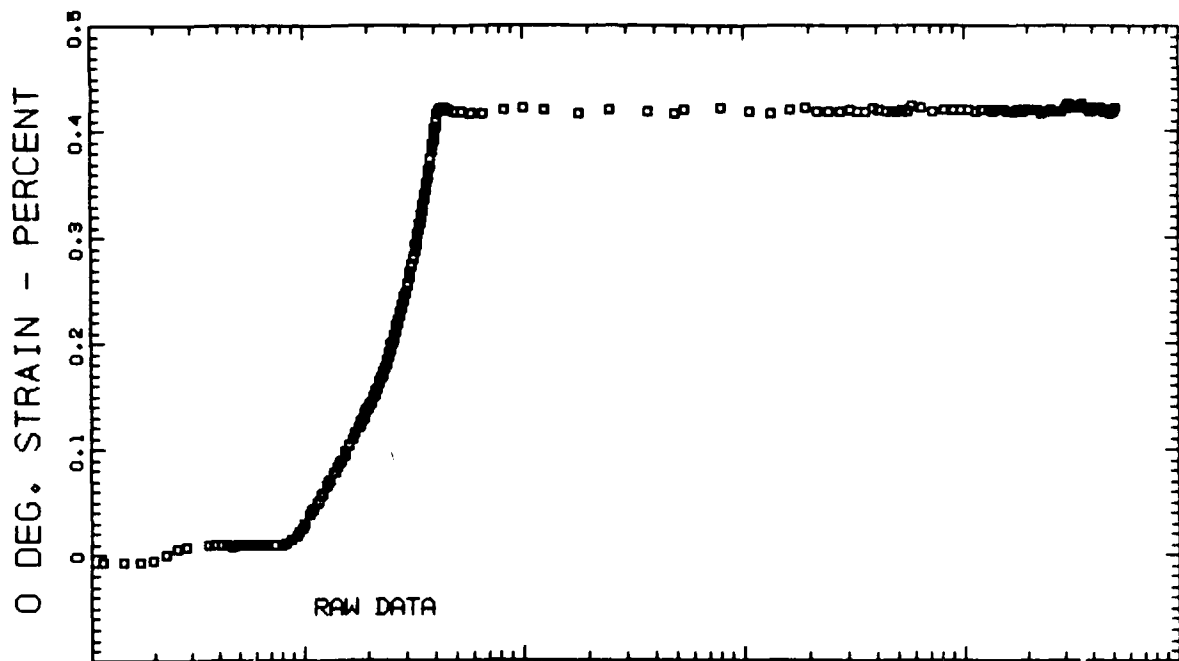

T300/5208 - STEP/RELAXATION - SPECIMEN No. 7 - STEP No. 1

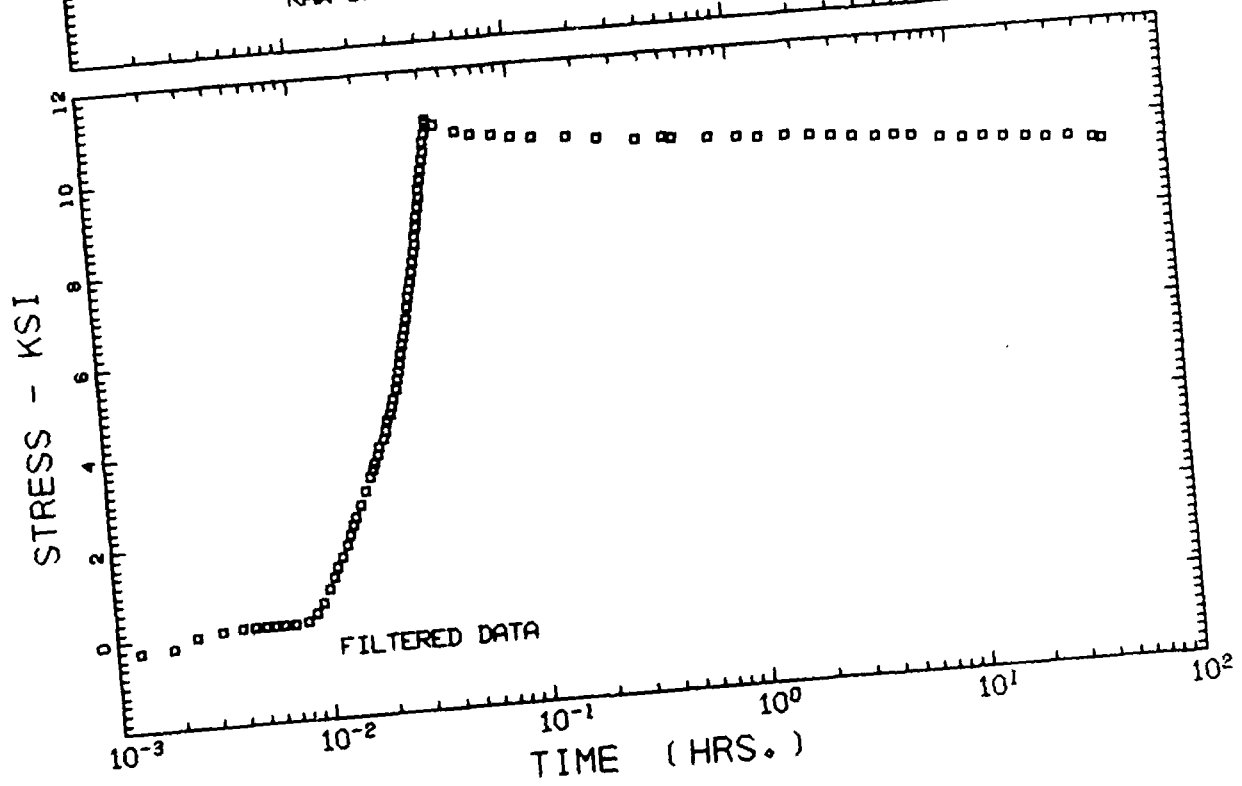
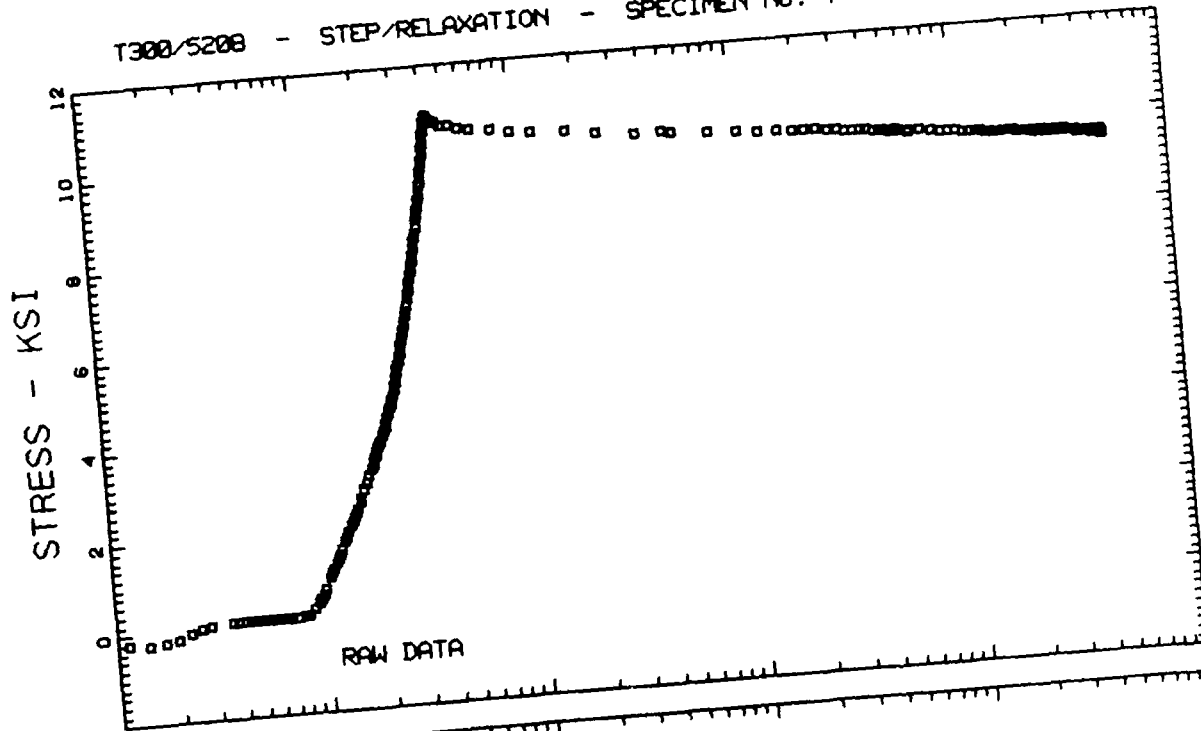

T300/5208 - STEP/RELAXATION - SPECIMEN No. 7 - STEP No. 1

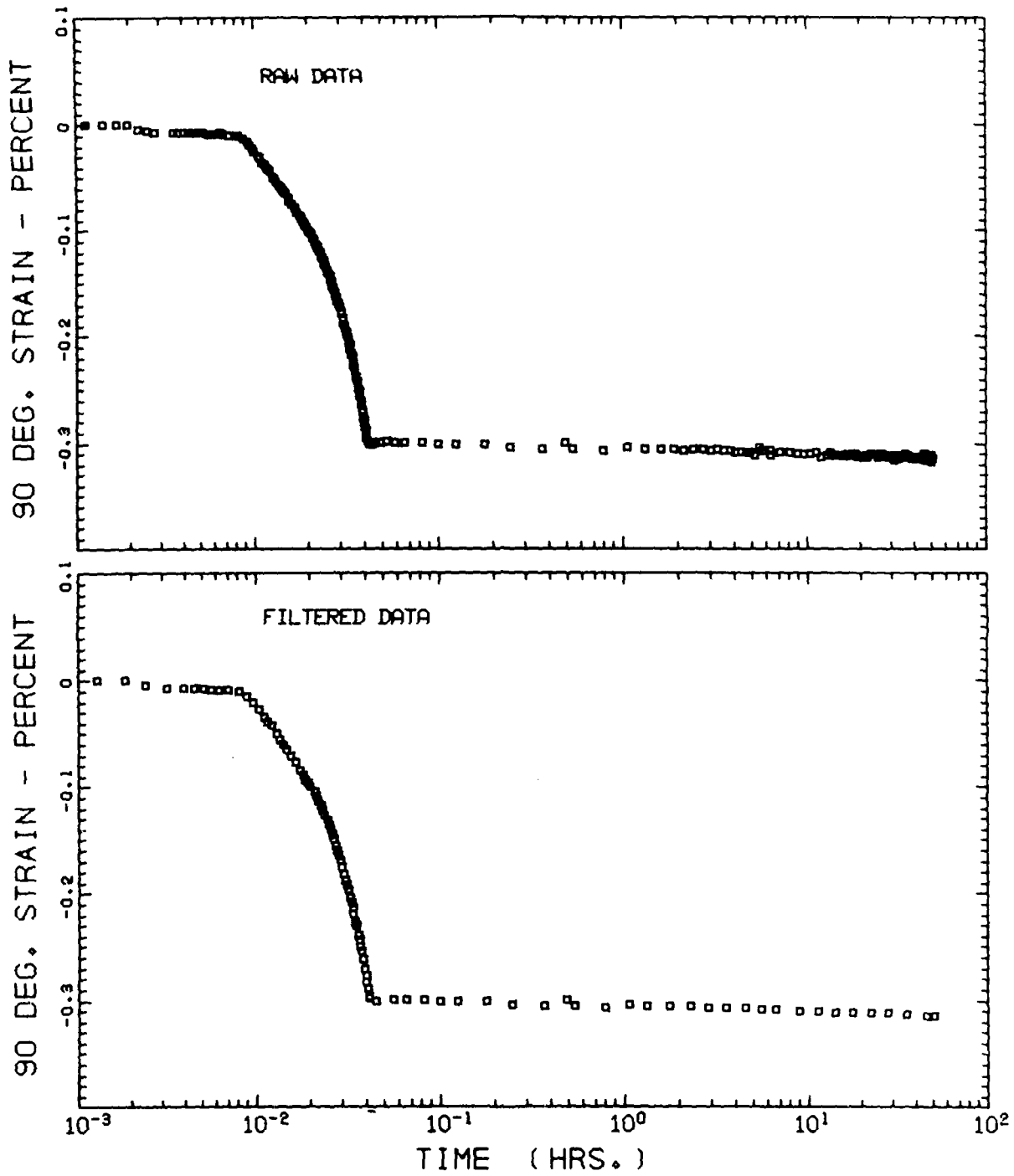

T300/5208 - STEP/RELAXATION - SPECIMEN No. 7 - STEP No. 1

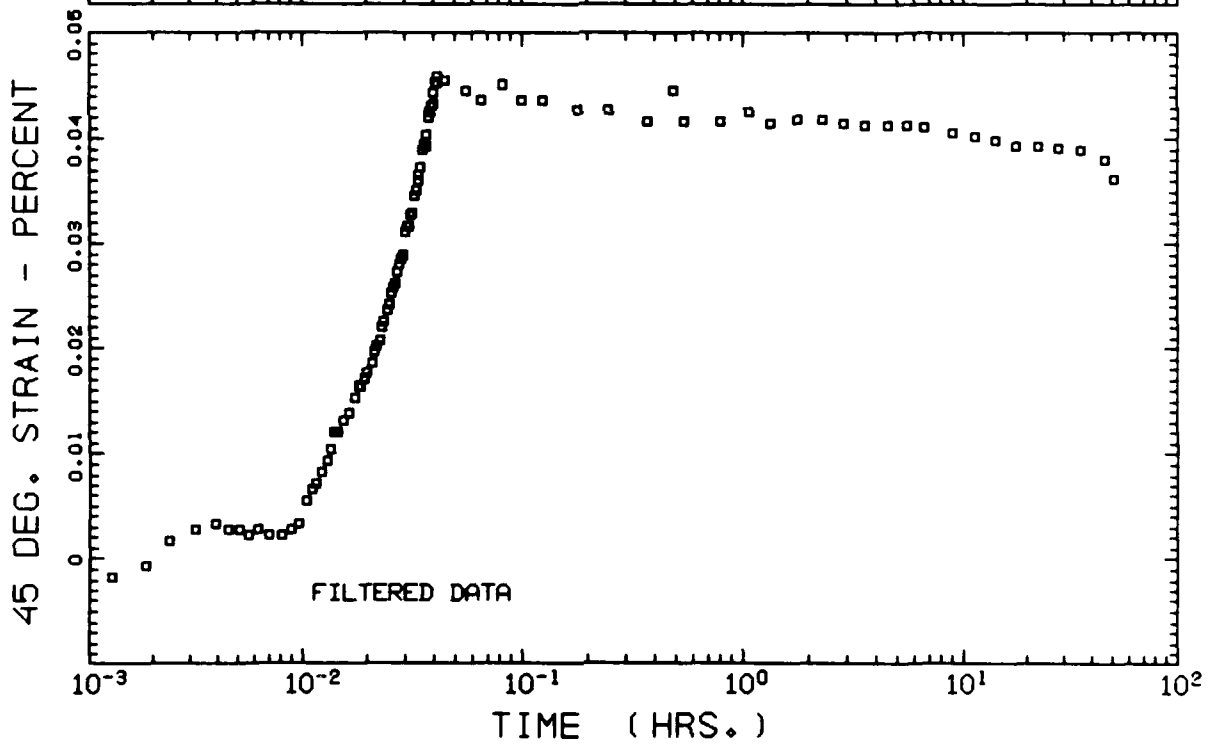
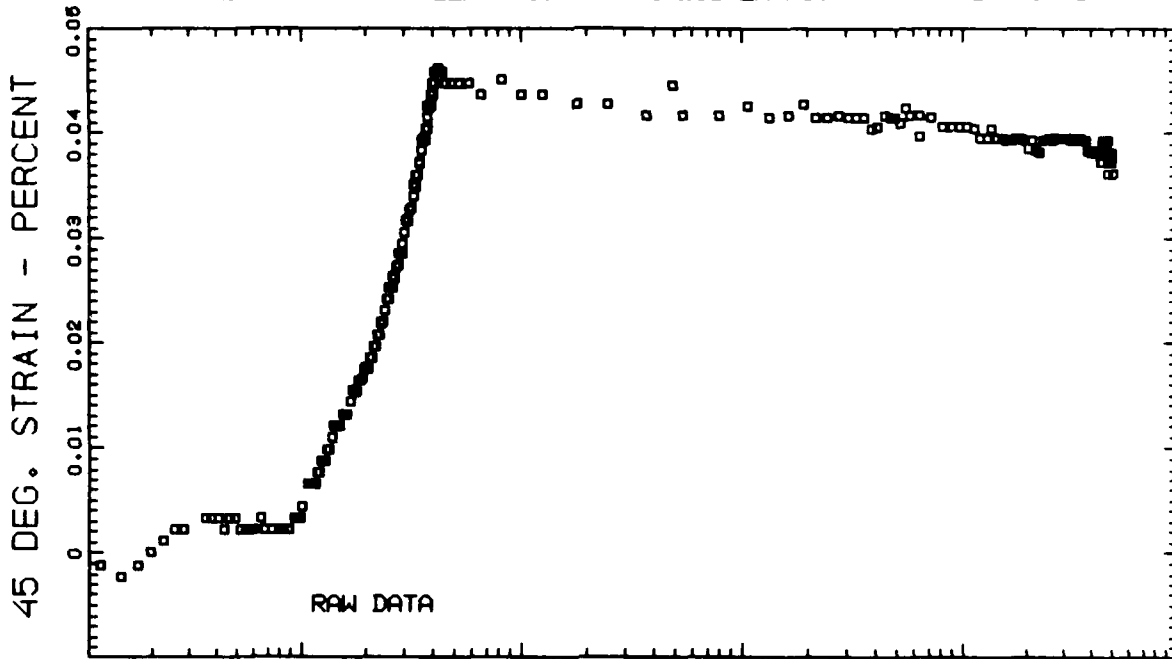

T300/5208 - STEP/RELAXATION - SPECIMEN No. 7 - STEP No. 2

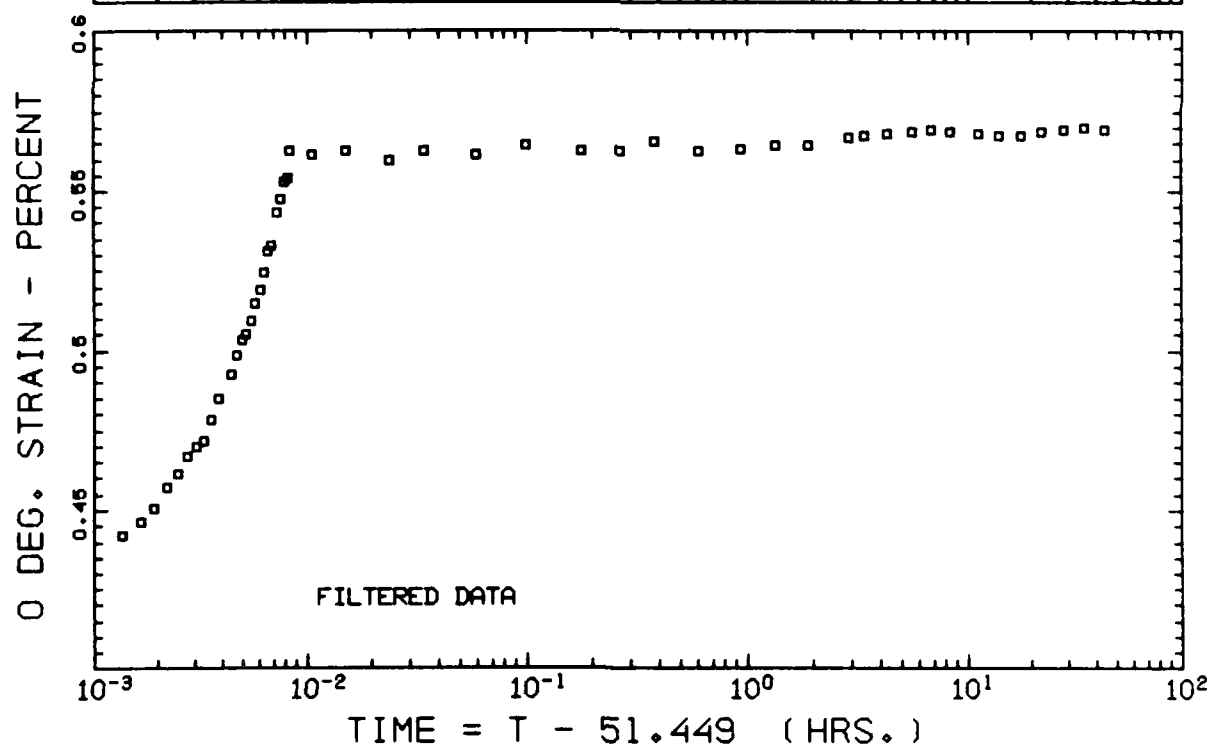
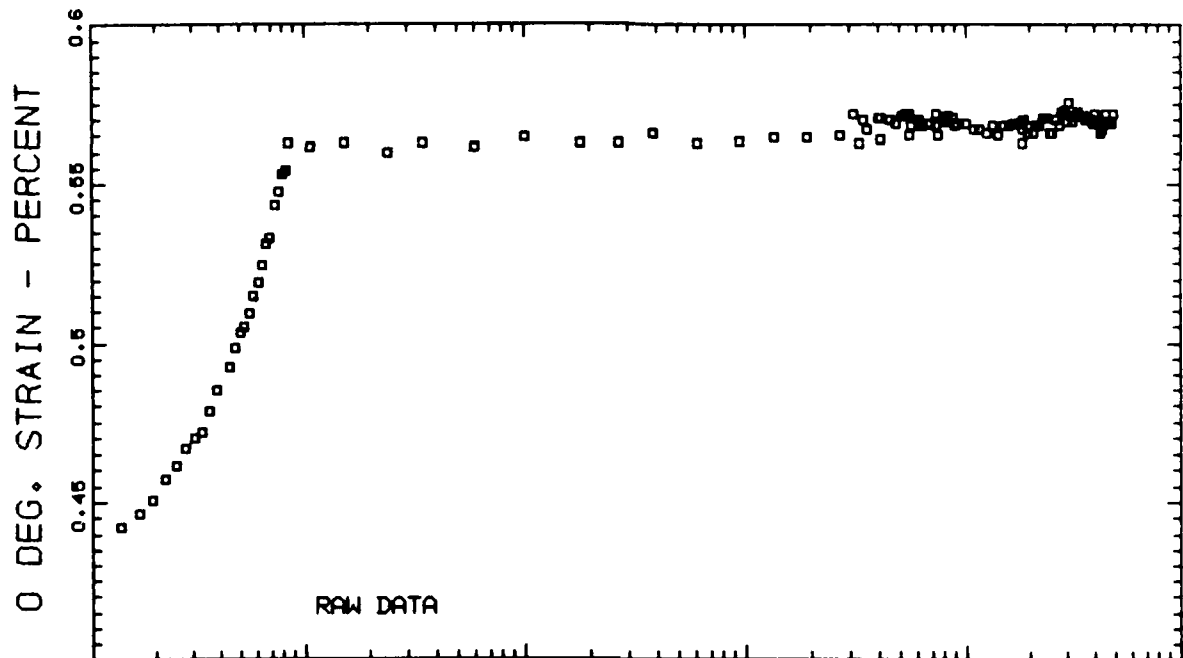

T300/5208 - STEP/RELAXATION - SPECIMEN No. 7 - STEP No. 2

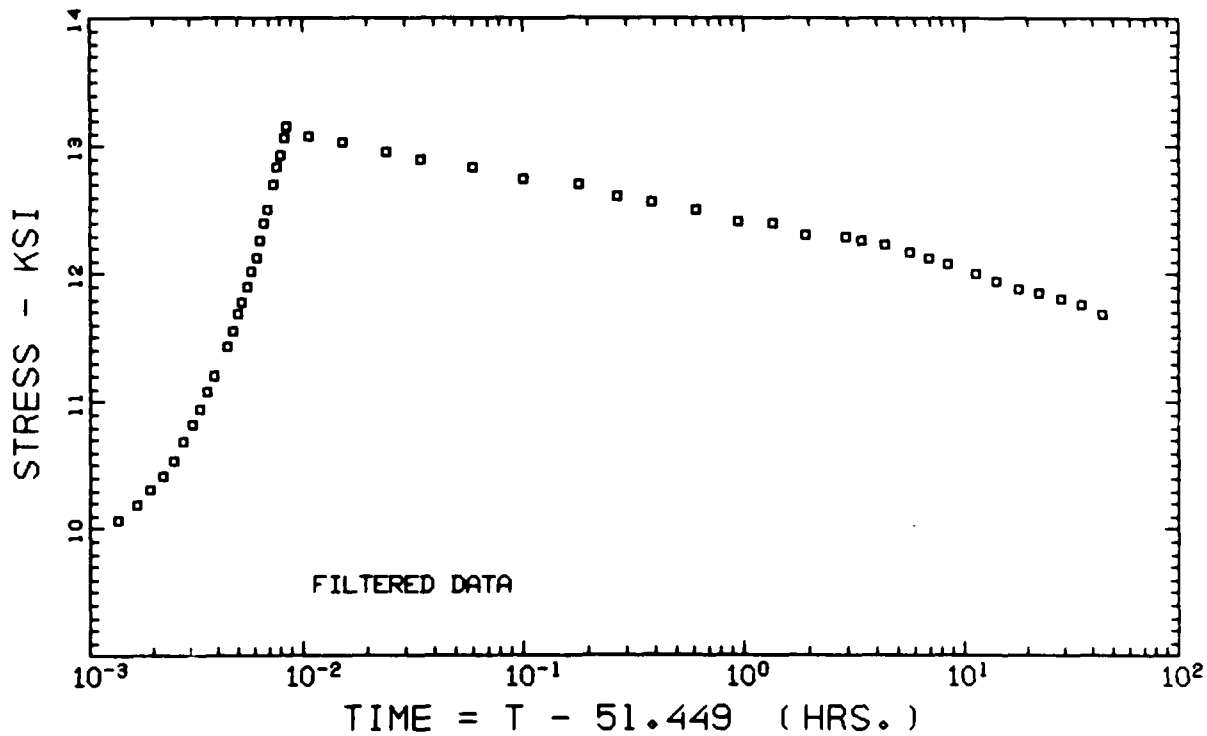
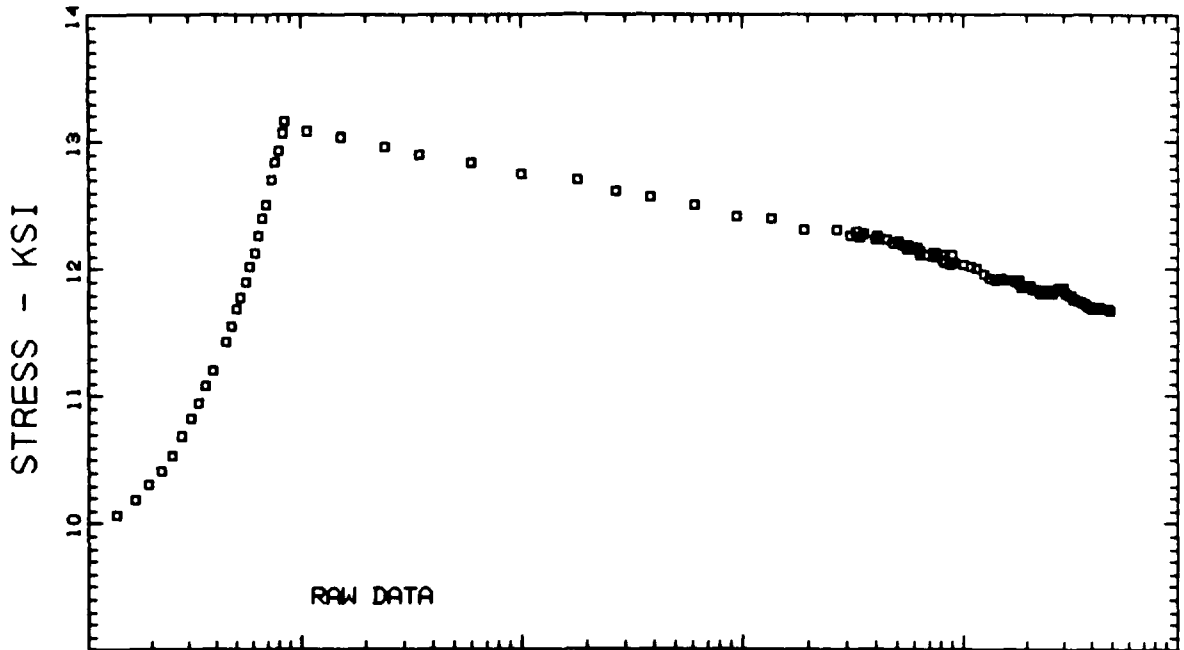

T300/5208 - STEP/RELAXATION - SPECIMEN No. 7 - STEP No. 2

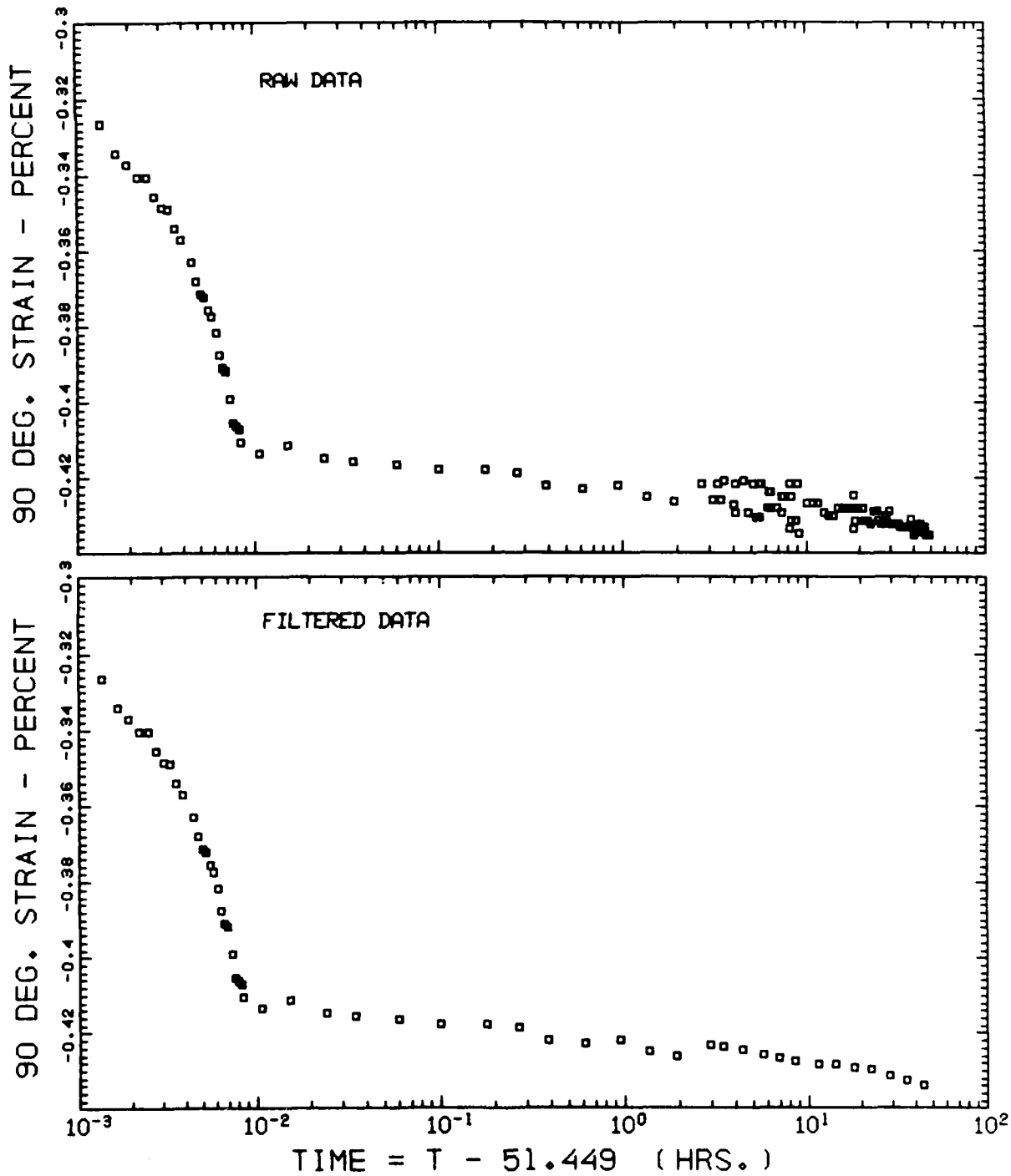



T300/5208 - STEP/RELAXATION - SPECIMEN No. 7 - STEP No. 2

45 DEG. STRAIN - PERCENT

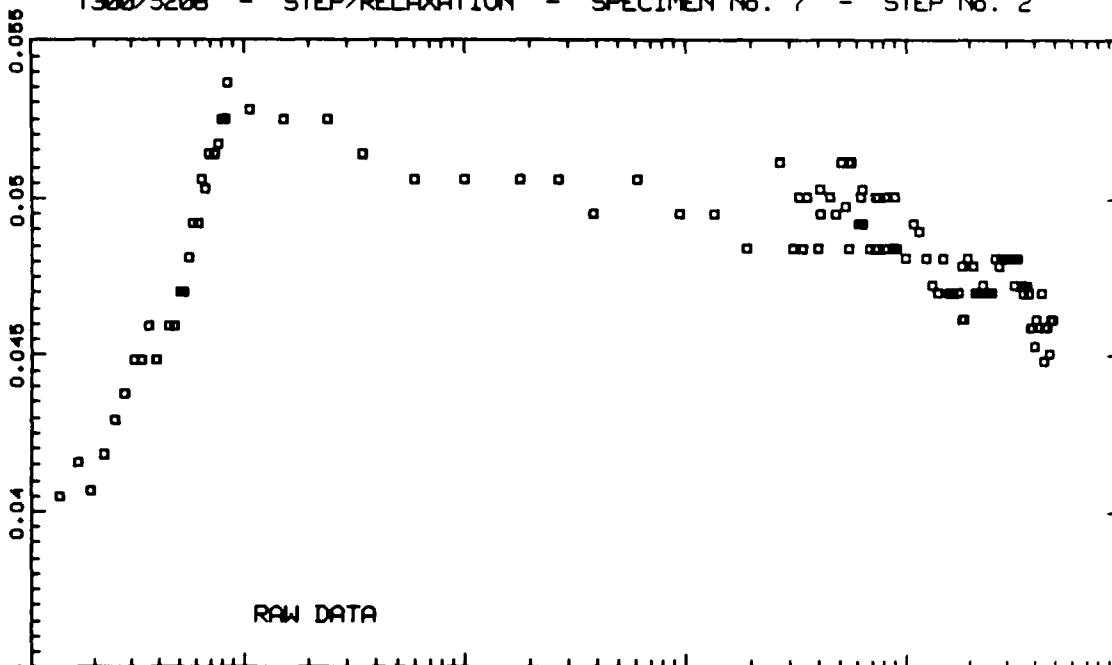

45 DEG. STRAIN - PERCENT

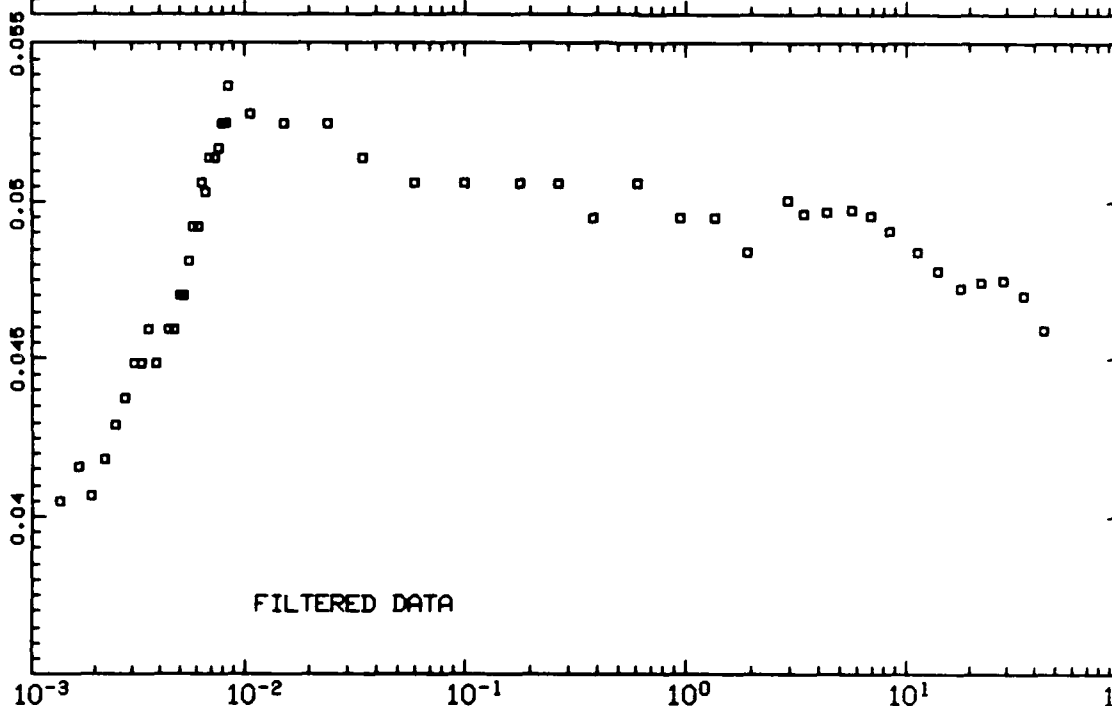

TIME = T - 51.449 (HRS.)

T300/S208 - STEP/RELAXATION - SPECIMEN No. 7 - STEP No. 3

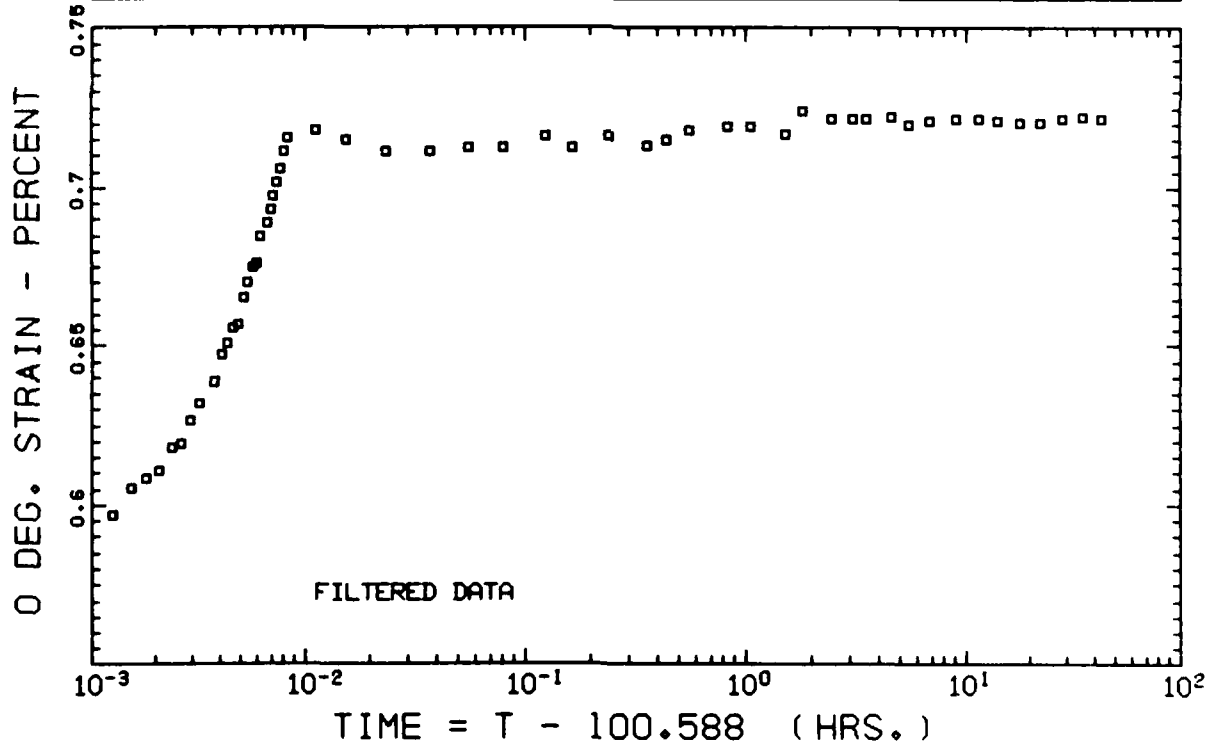
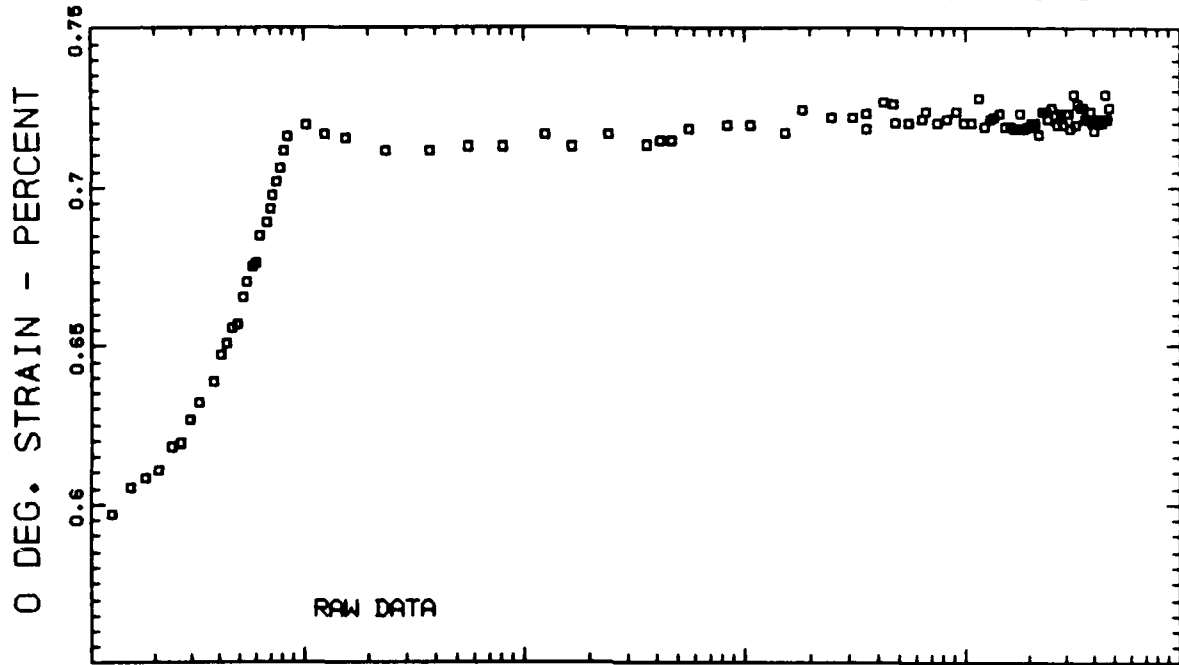

T300/5208 - STEP/RELAXATION - SPECIMEN No. 7 - STEP No. 3

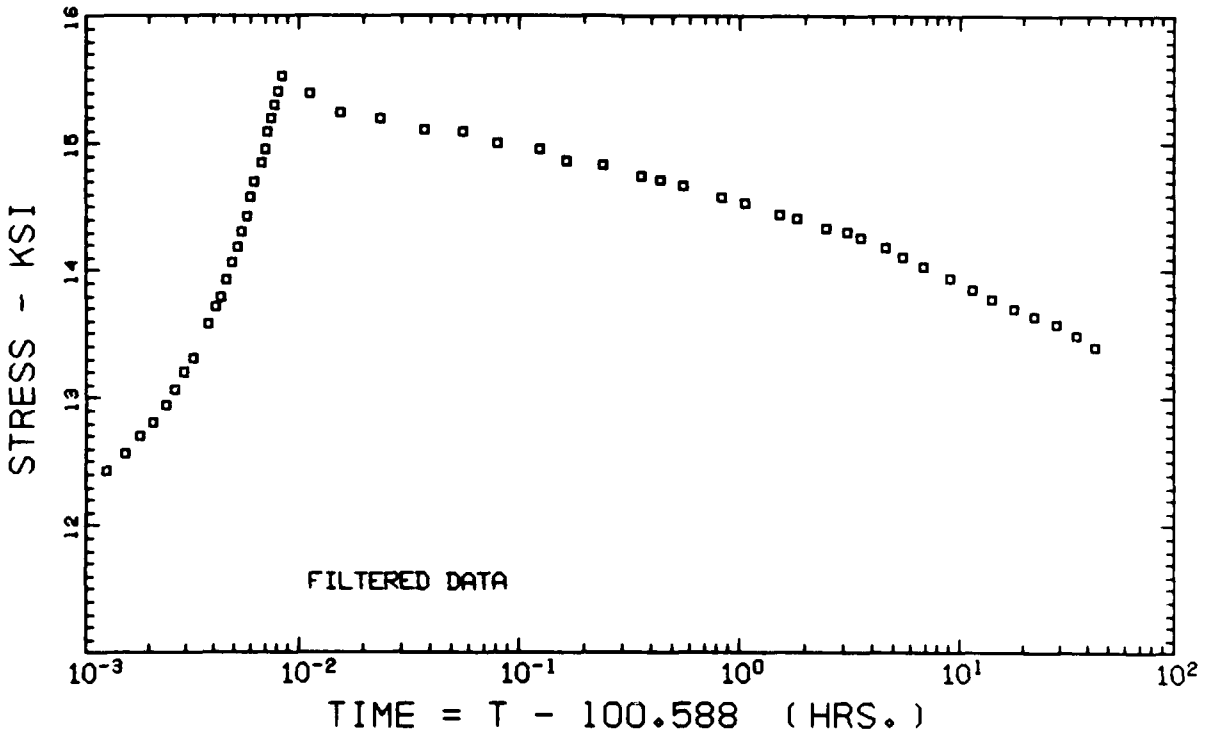
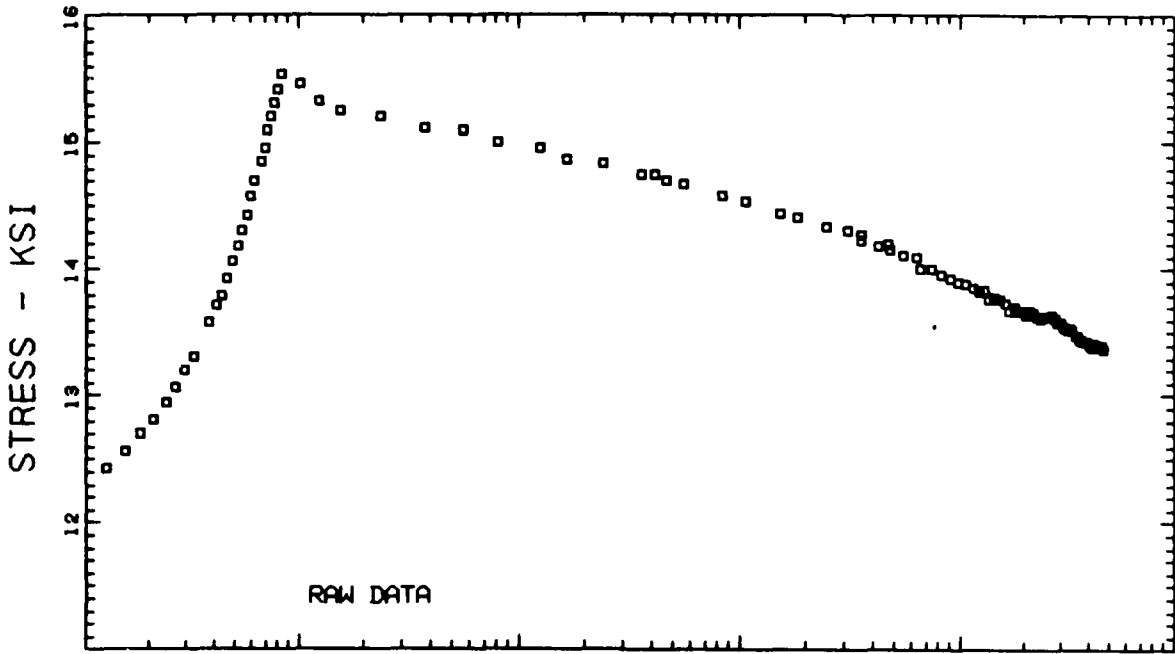

T300/5208 - STEP/RELAXATION - SPECIMEN No. 7 - STEP No. 3

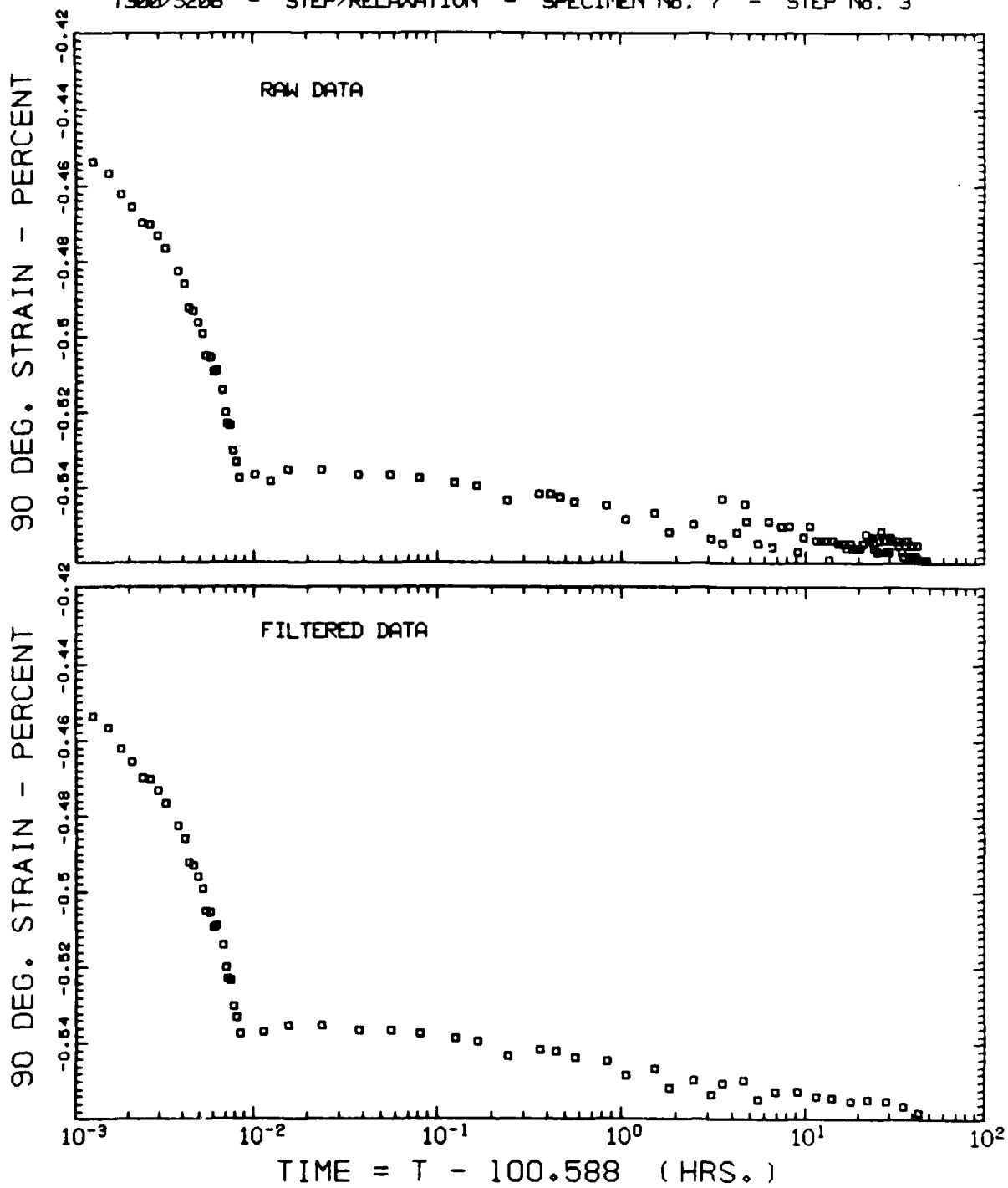

T300/5208 - STEP/RELAXATION - SPECIMEN No. 7 - STEP No. 3

45 DEG. STRAIN - PERCENT

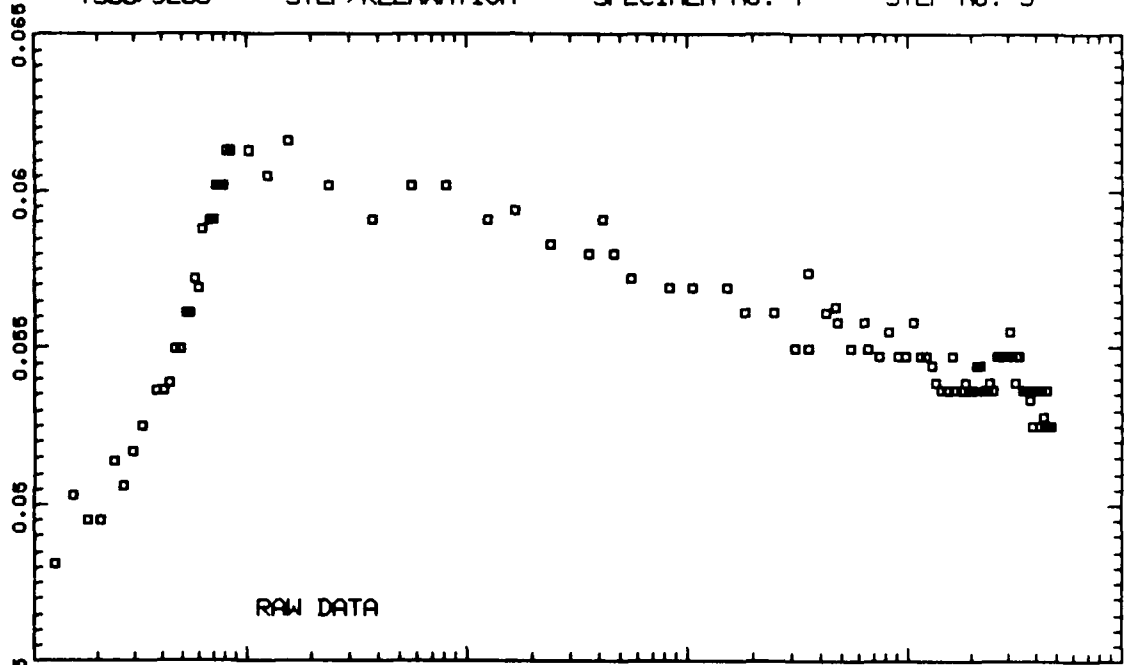

45 DEG. STRAIN - PERCENT

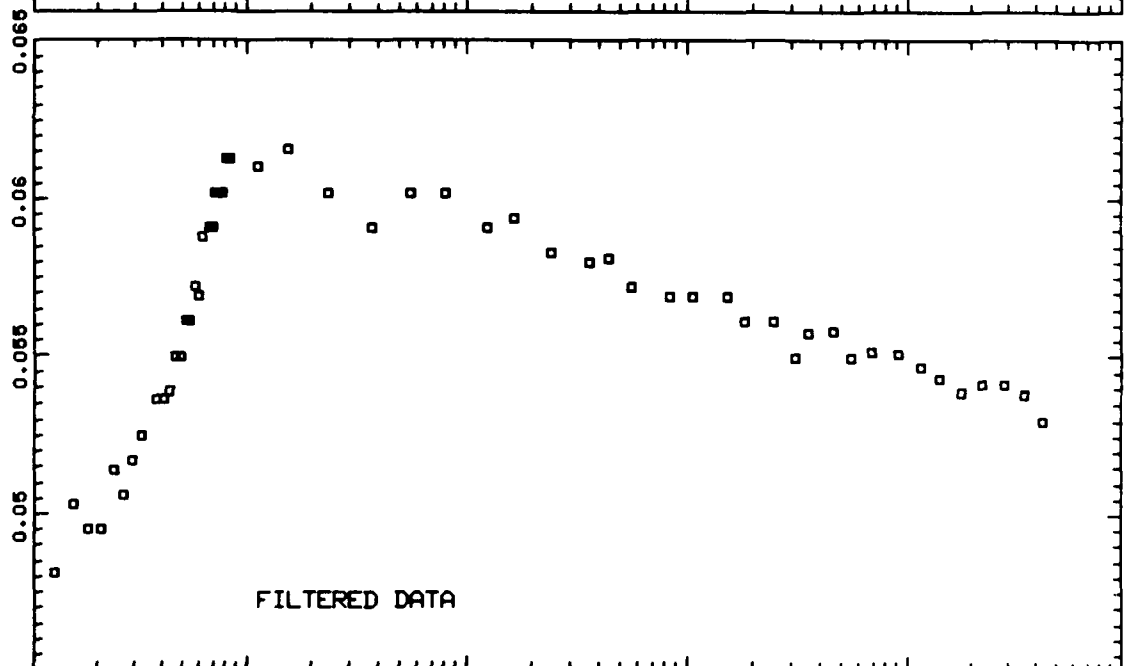

TIME = T - 100.588 (HRS.)

T300/5208 - STEP/RELAXATION - SPECIMEN No. 7 - STEP No. 4

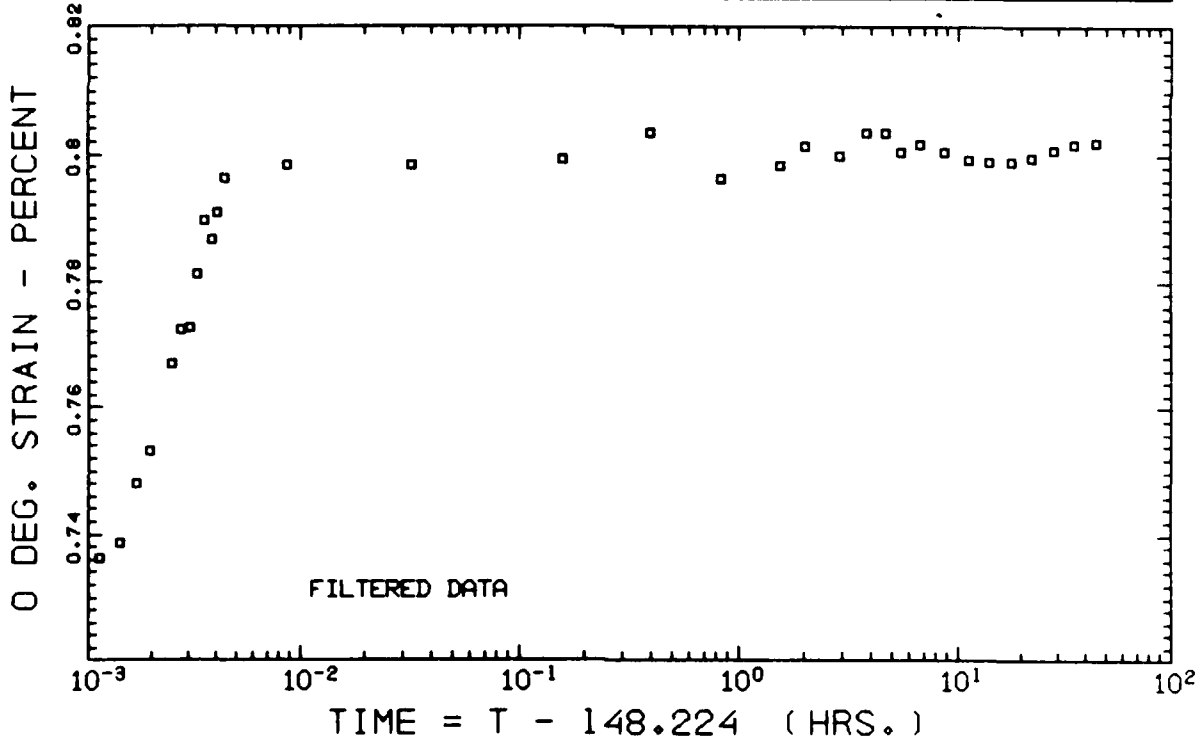
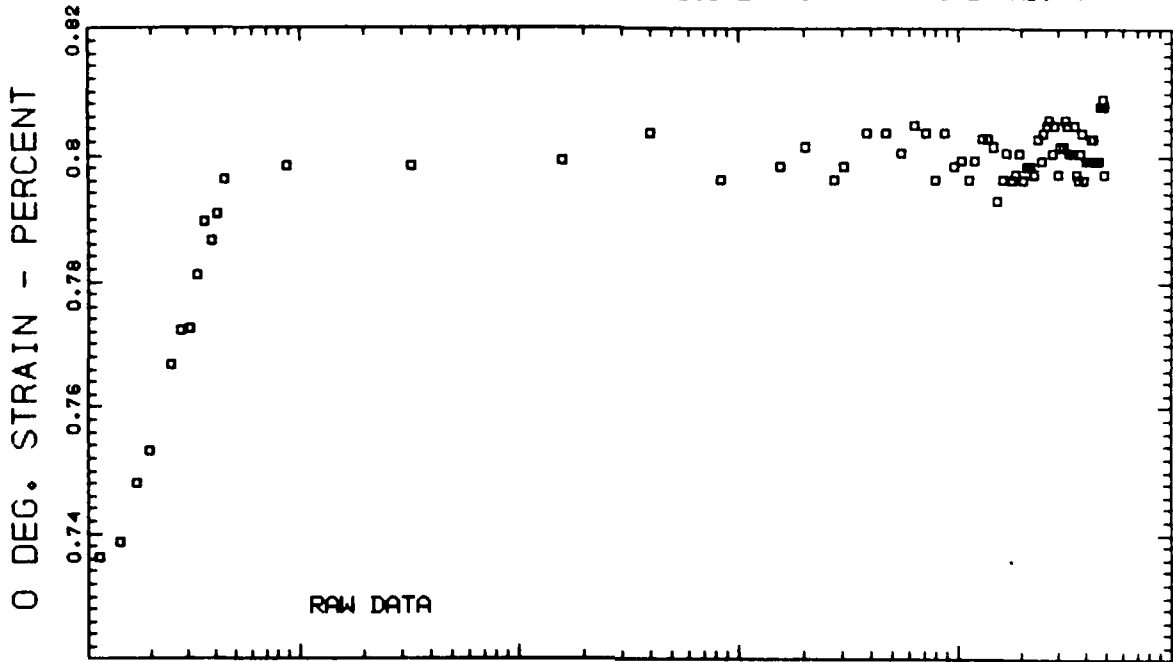

T300/5208 - STEP/RELAXATION - SPECIMEN No. 7 - STEP No. 4

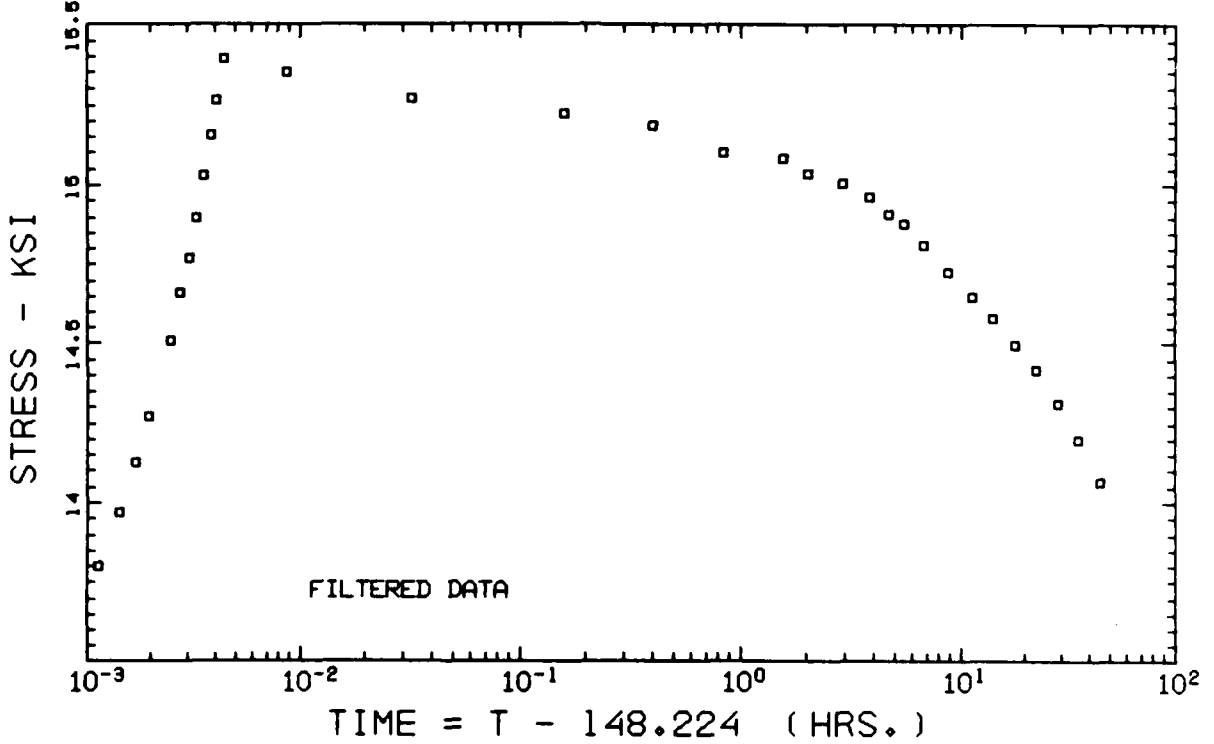
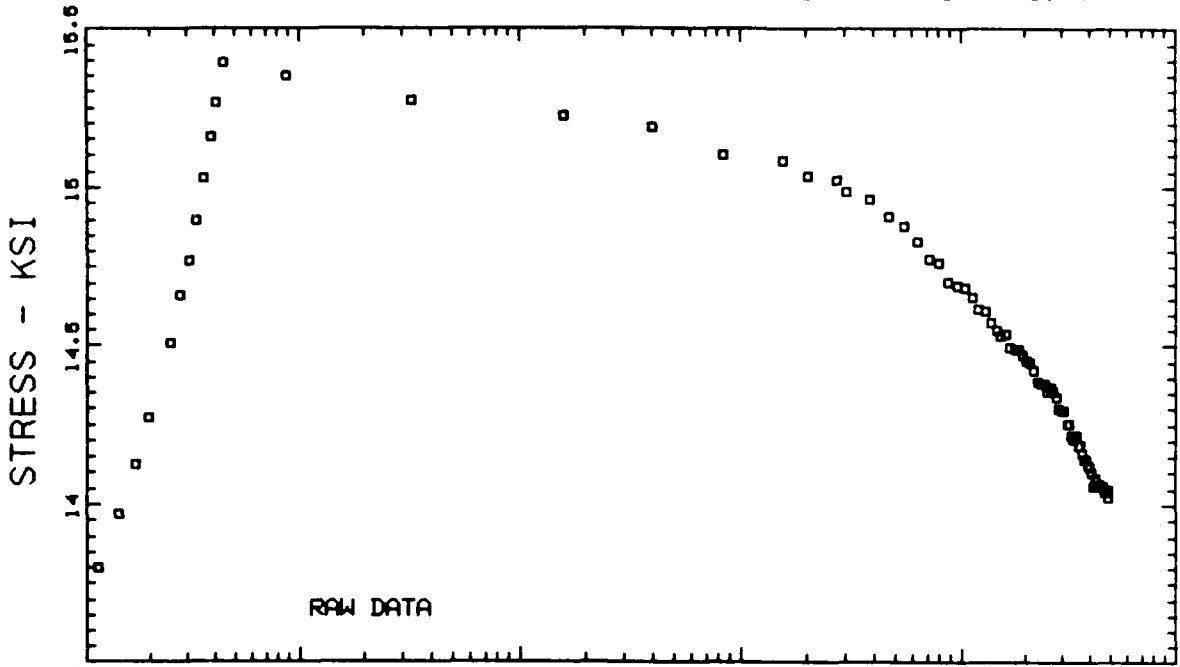

T300/S208 - STEP/RELAXATION - SPECIMEN No. 7 - STEP No. 4

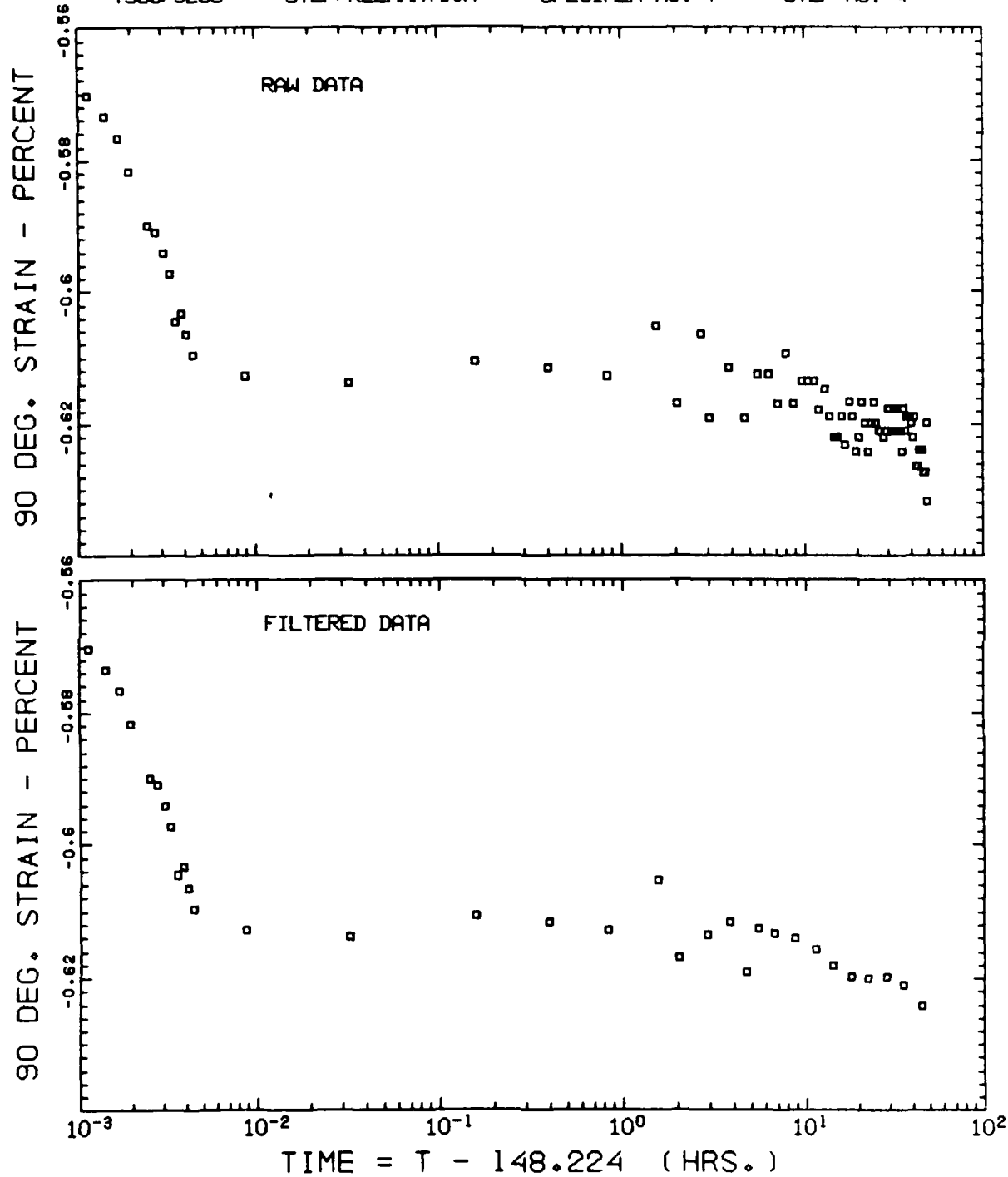



T300/5208 - STEP/RELAXATION - SPECIMEN No. 7 - STEP No. 4

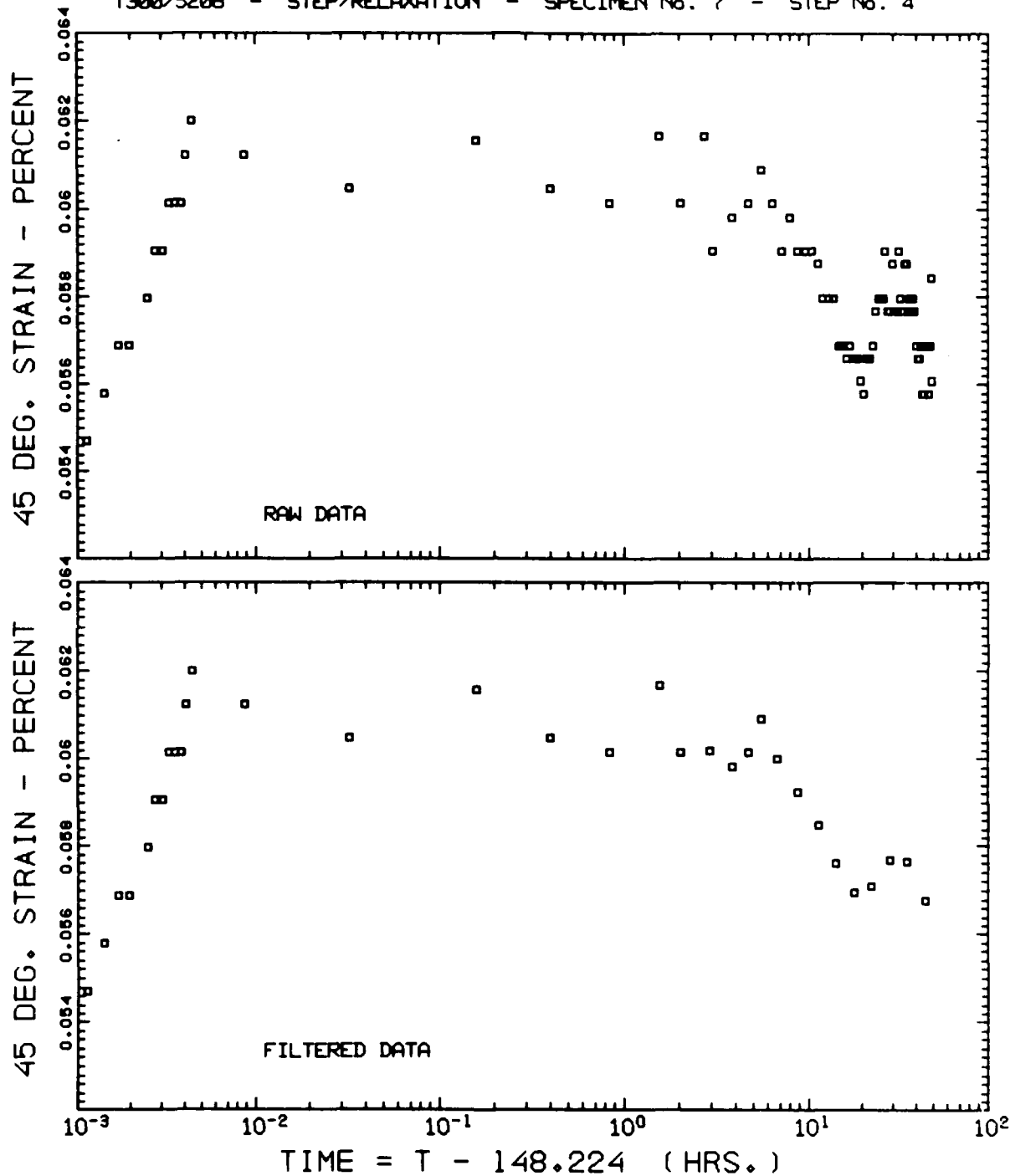

T300/5206 - STEP/RELAXATION - SPECIMEN No. 7 - STEP No. 5

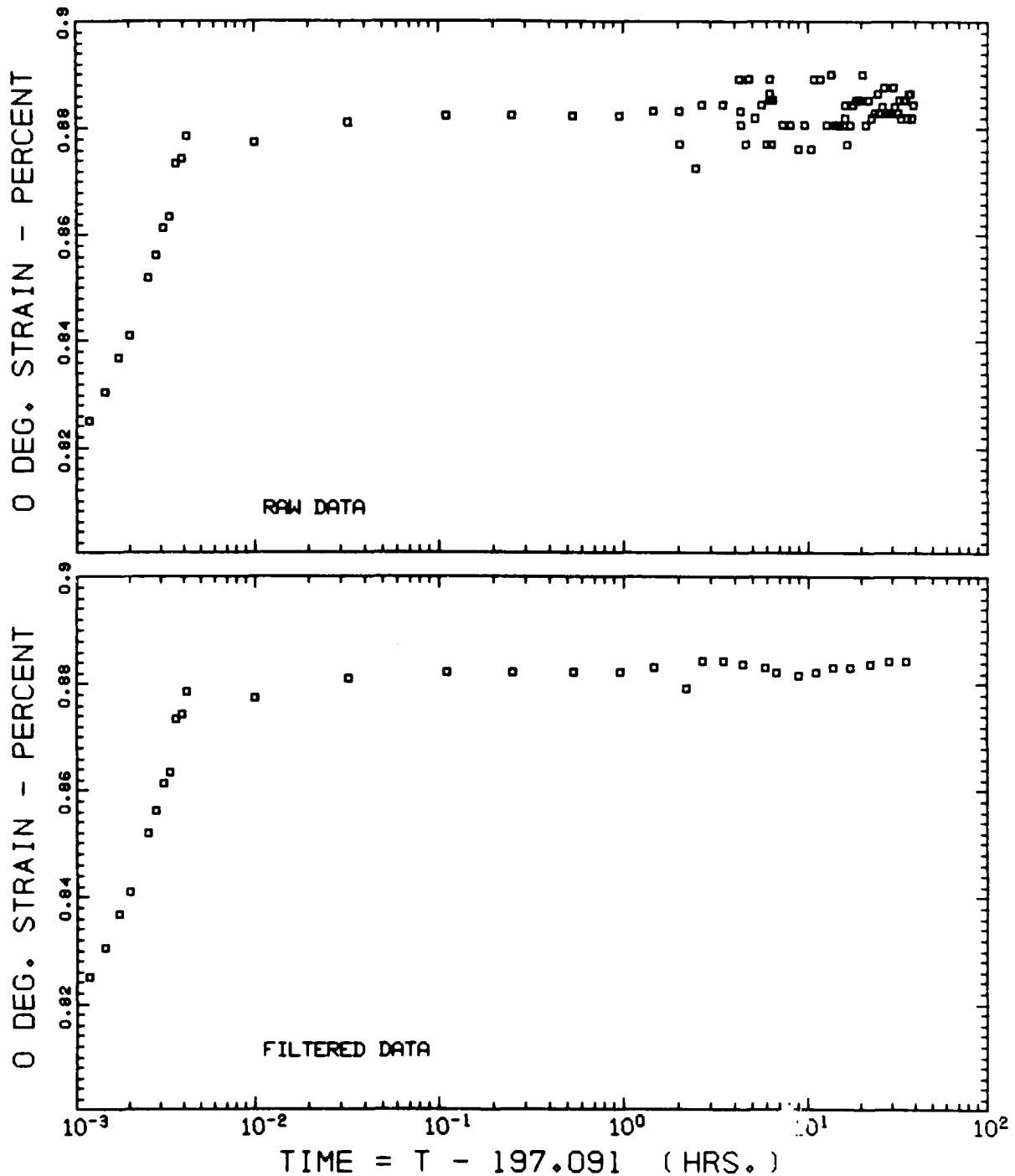

T300/5208 - STEP/RELAXATION - SPECIMEN No. 7 - STEP No. 5

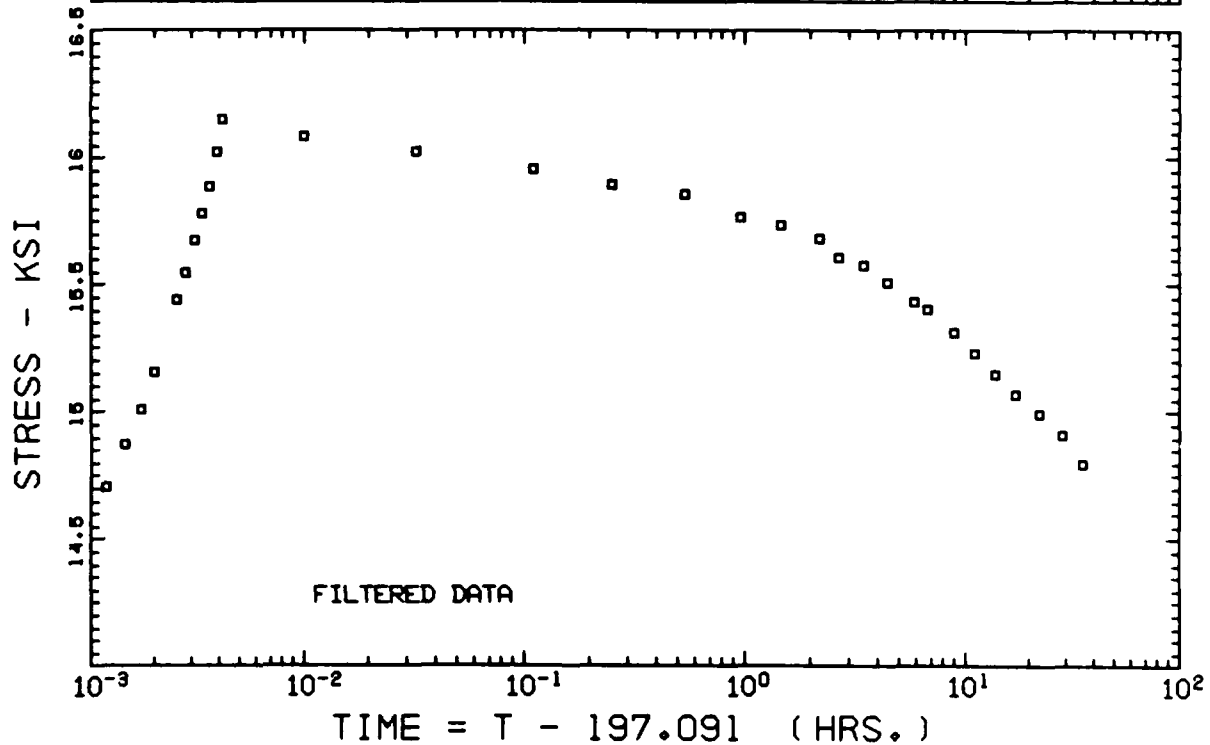
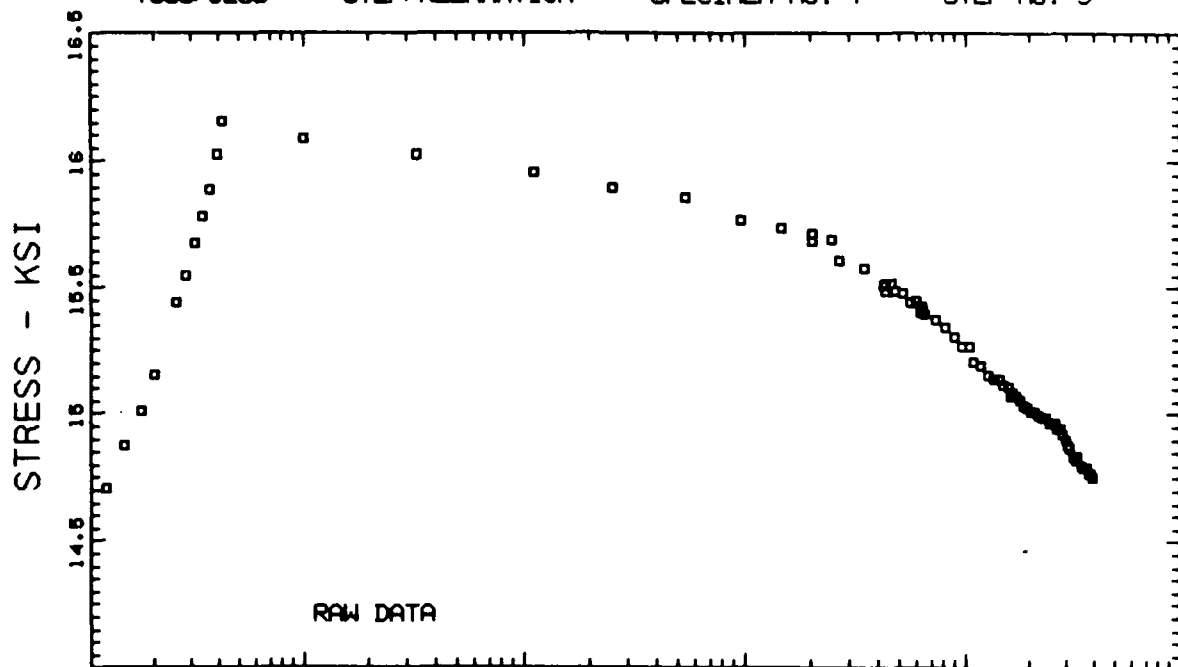

TIME = T - 197.091 (HRS.)

T300/5208 - STEP/RELAXATION - SPECIMEN No. 7 - STEP No. 5

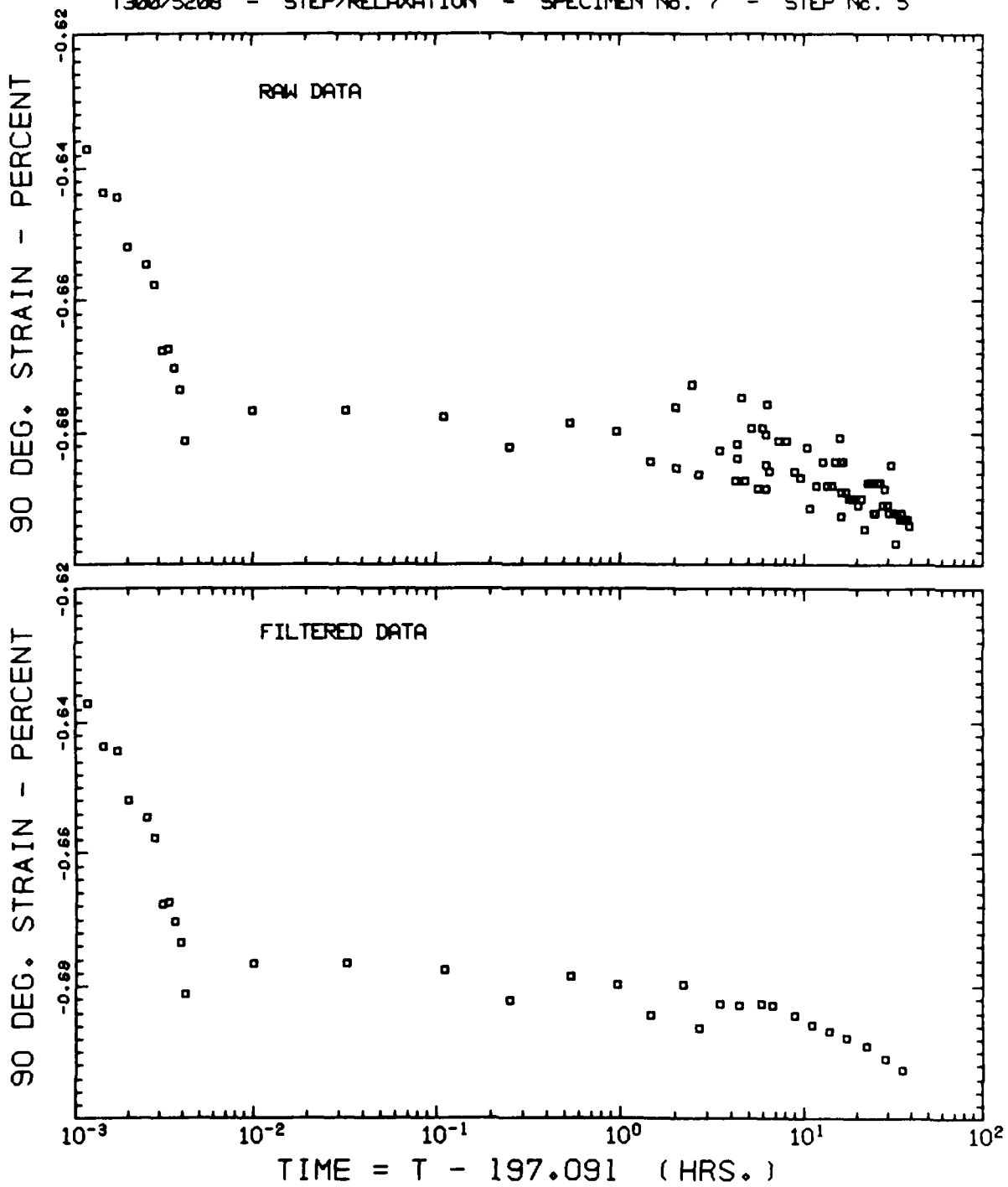

T300/5208 - STEP/RELAXATION - SPECIMEN No. 7 - STEP No. 5

45 DEG. STRAIN - PERCENT

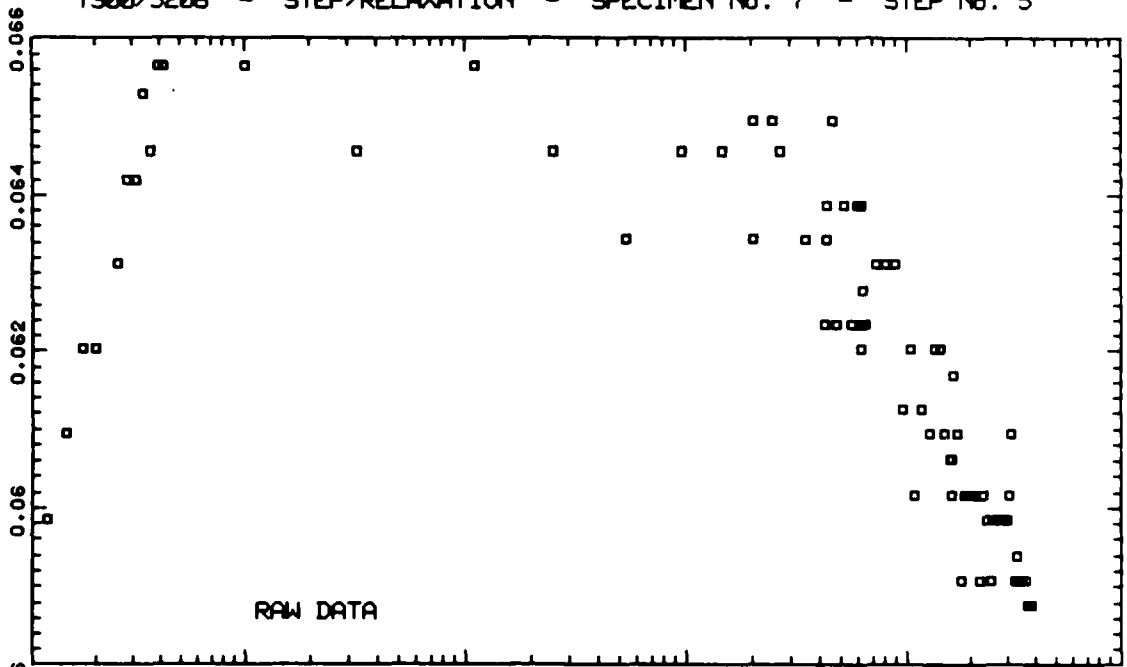

45 DEG. STRAIN - PERCENT

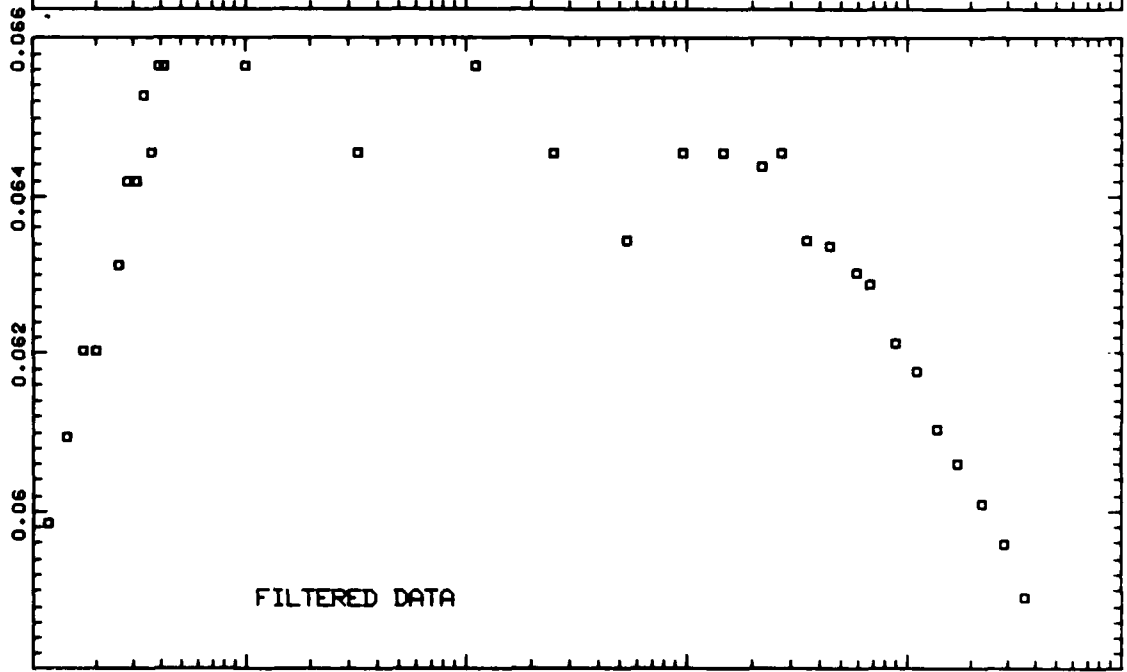

TIME = T - 197.091 (HRS.)

T300/5208 - STEP/RELAXATION - SPECIMEN No. 7 - STEP No. 6

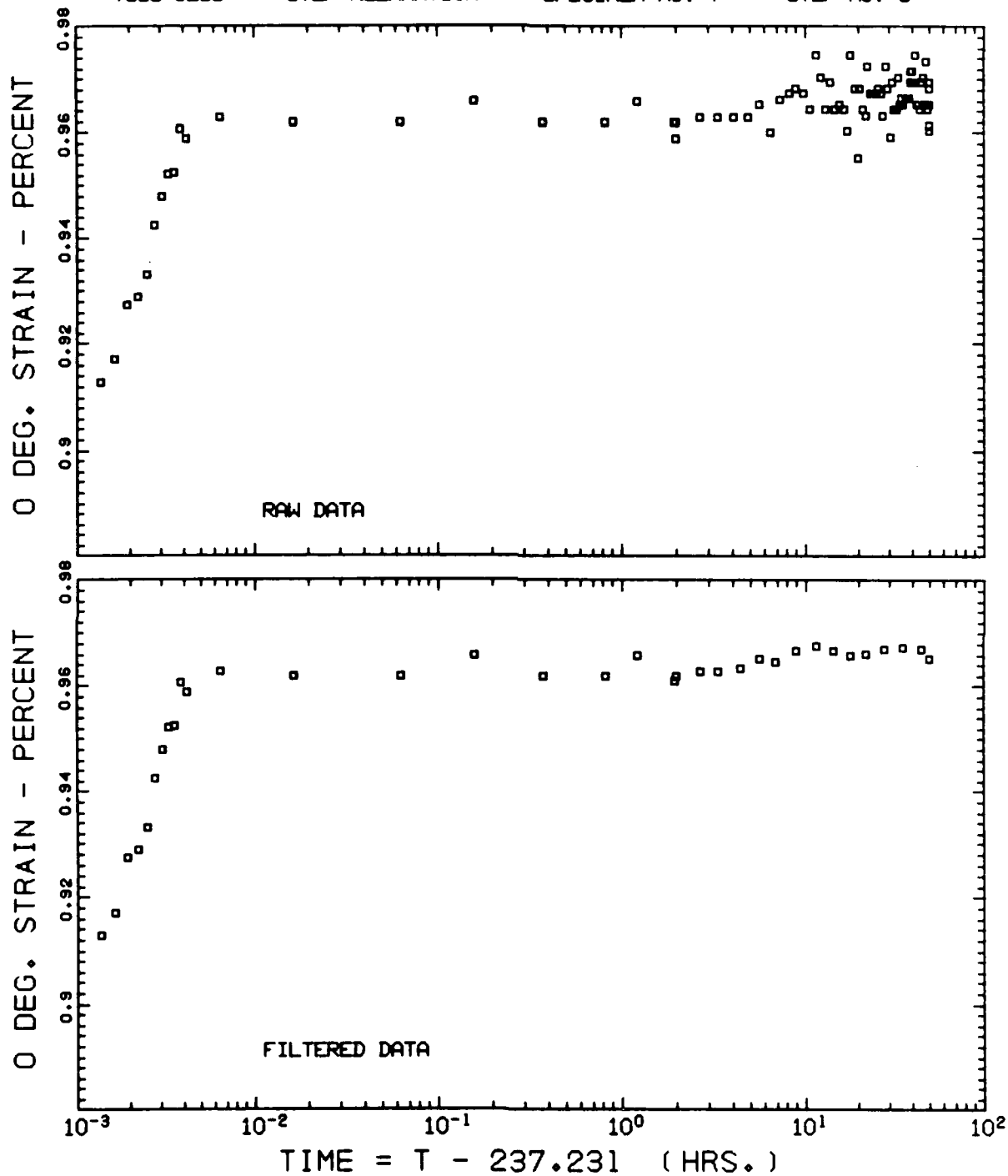

T300/5208 - STEP/RELAXATION - SPECIMEN No. 7 - STEP No. 6

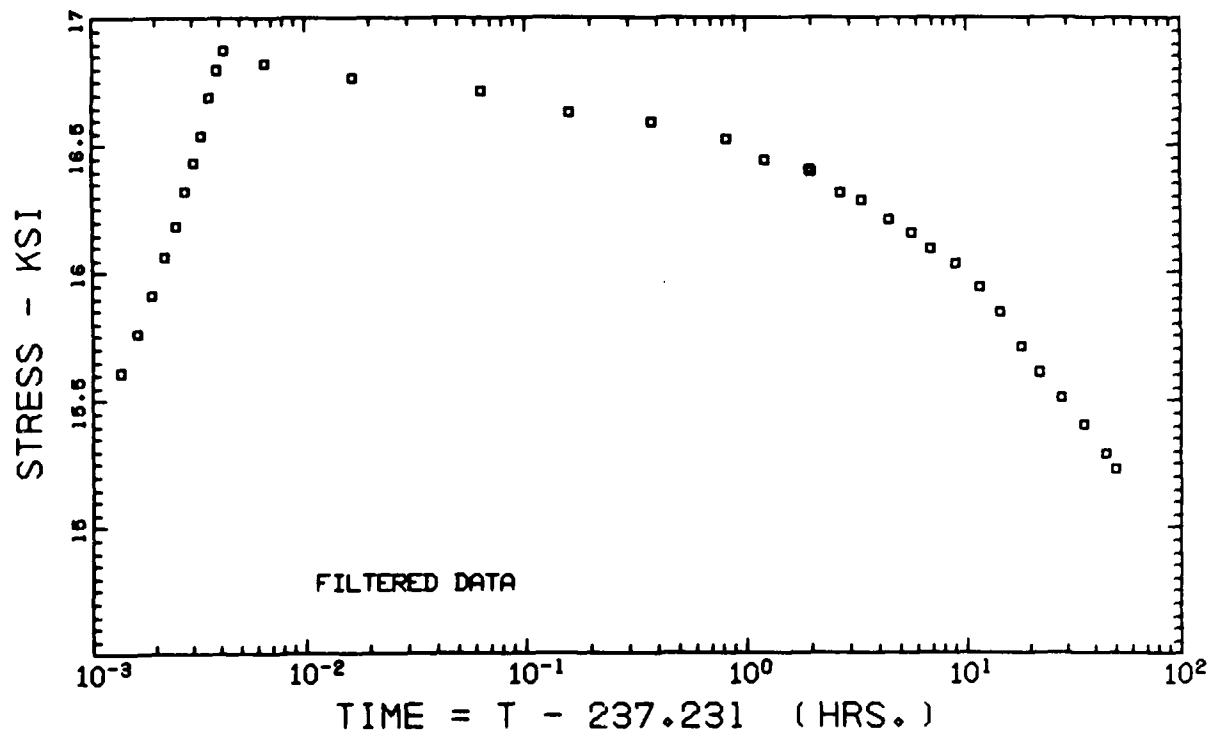
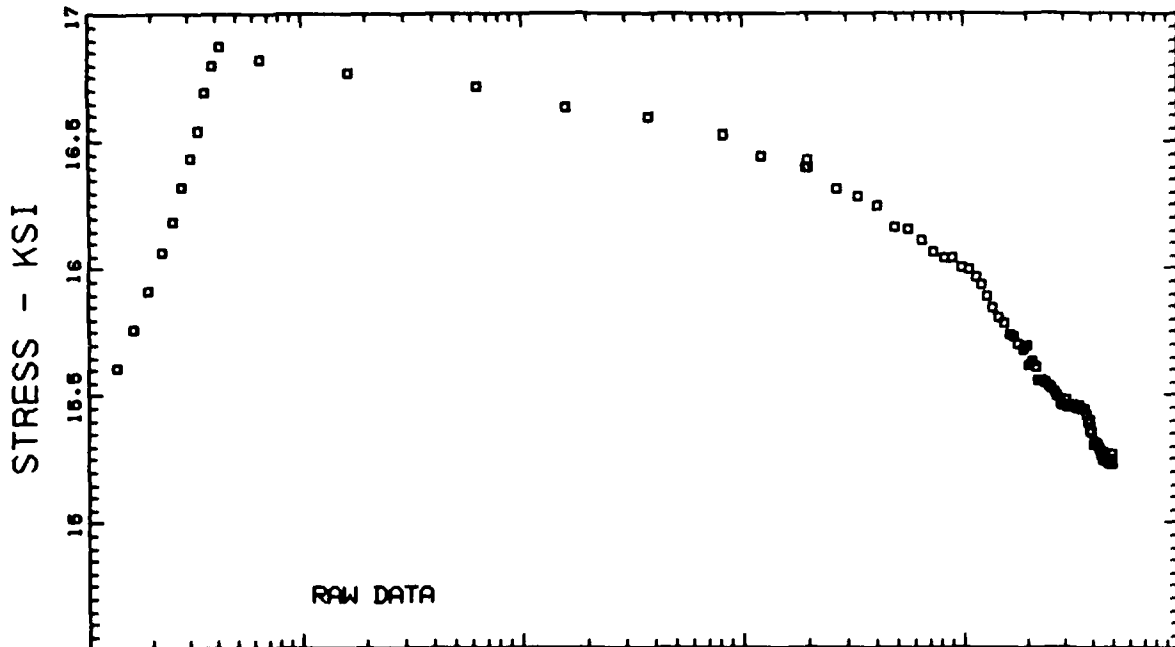

T300/5208 - STEP/RELAXATION - SPECIMEN No. 7 - STEP No. 6

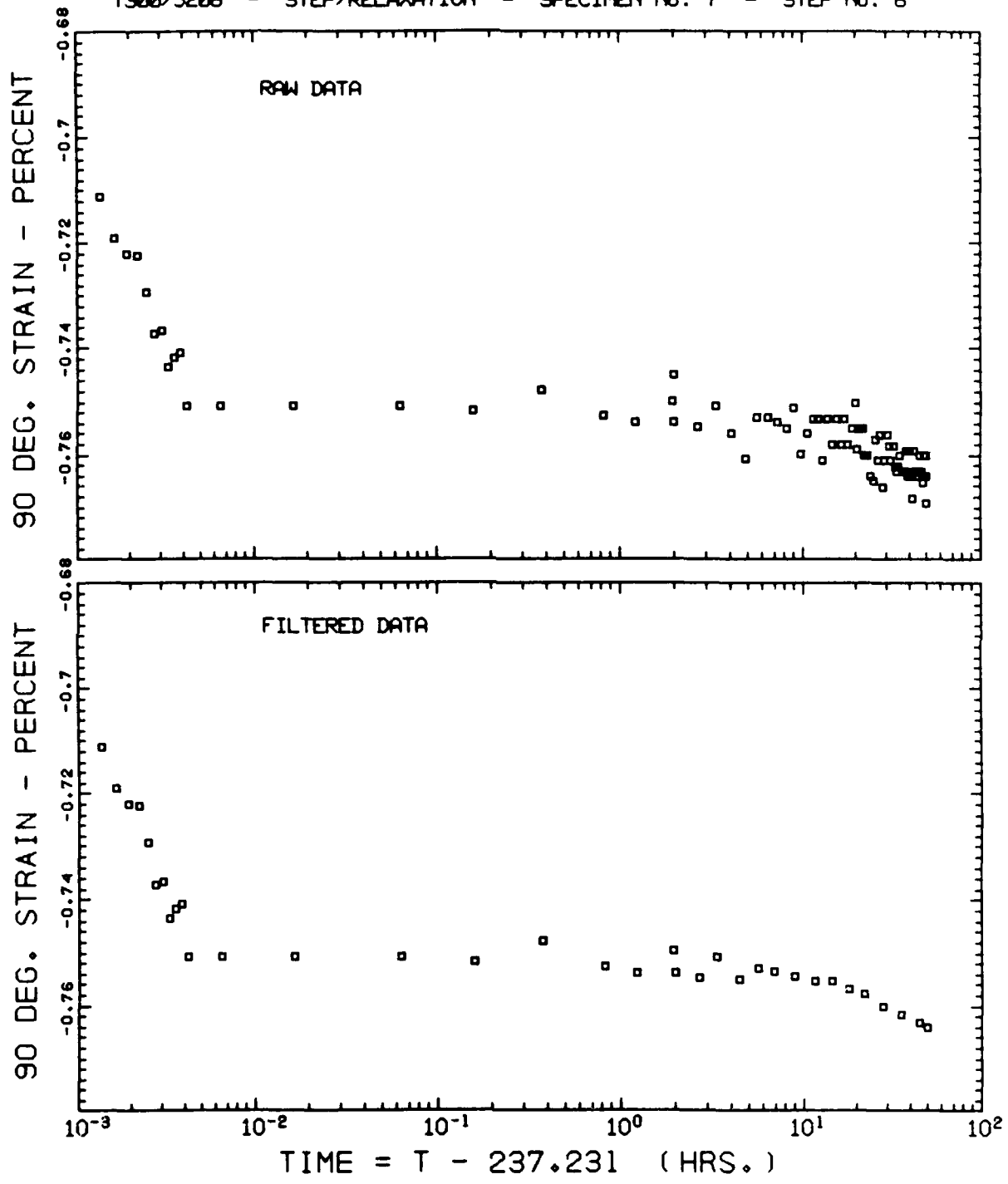



T300/5208 - STEP/RELAXATION - SPECIMEN No. 7 - STEP No. 6

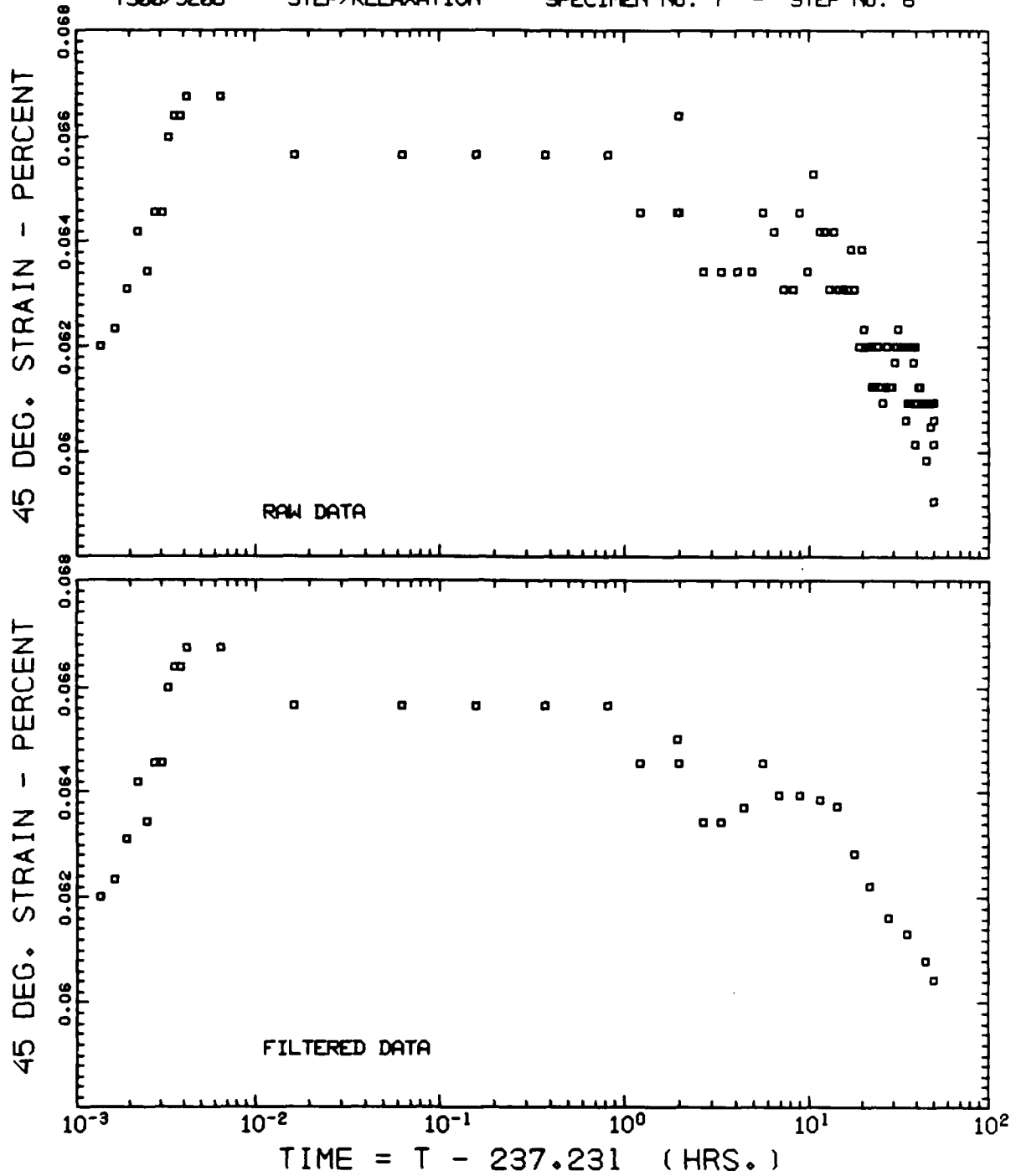

T300/S208 - STEP/RELAXATION - SPECIMEN No. 7 - STEP No. 7

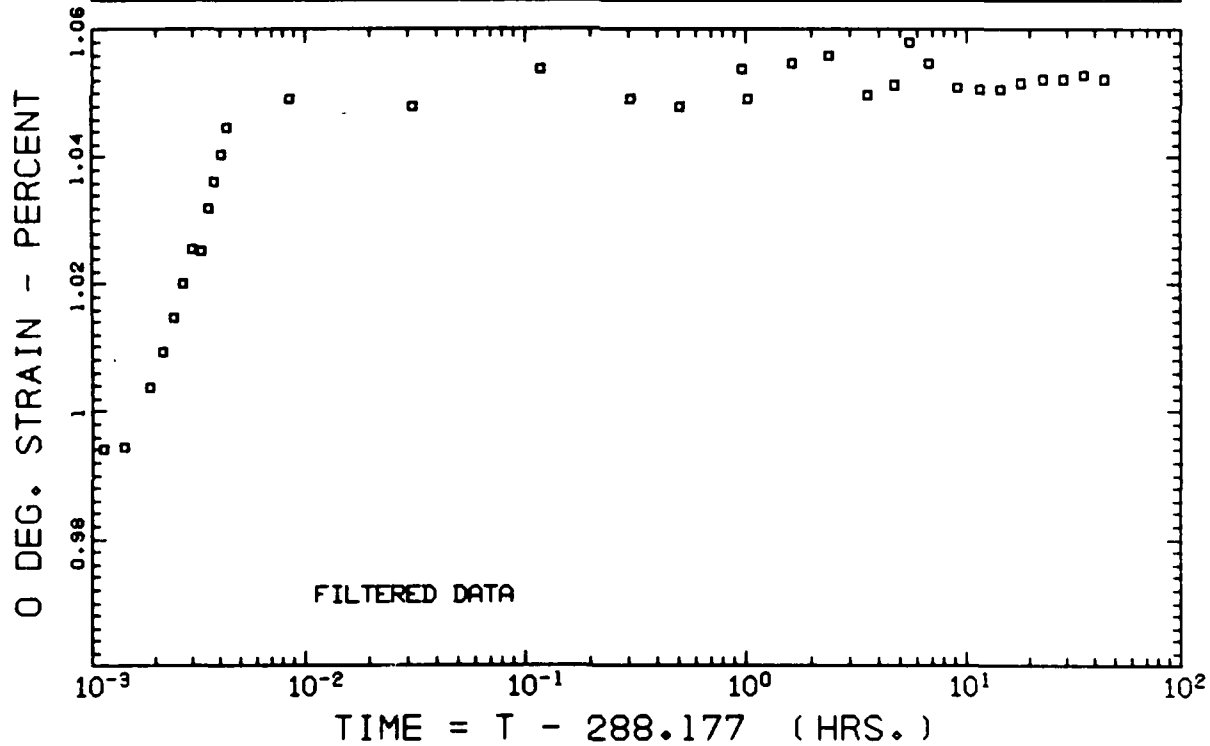
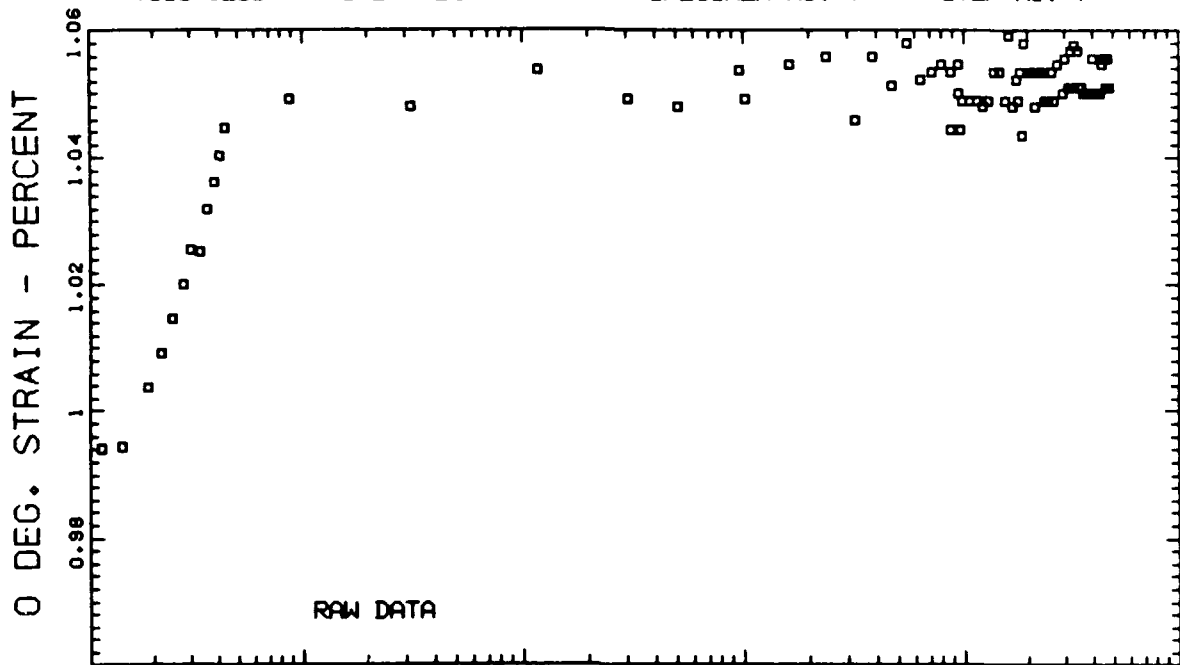

T302/5208 - STEP/RELAXATION - SPECIMEN No. 7 - STEP No. 7

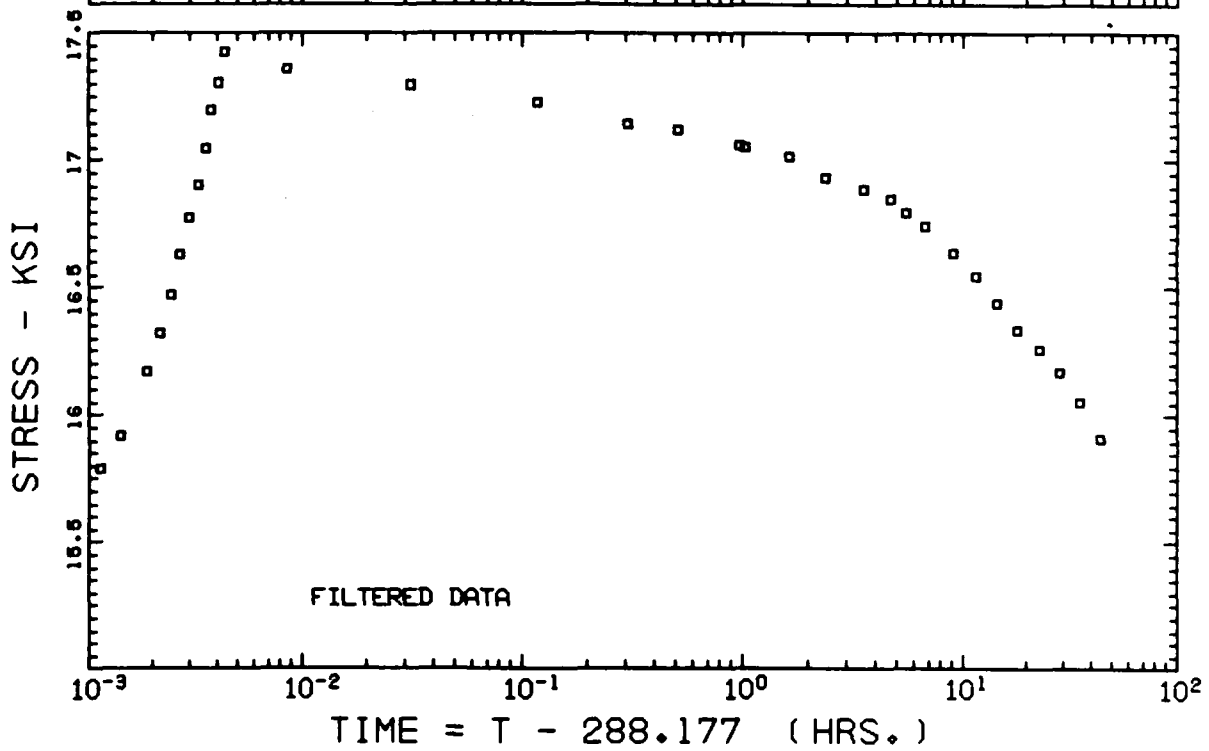
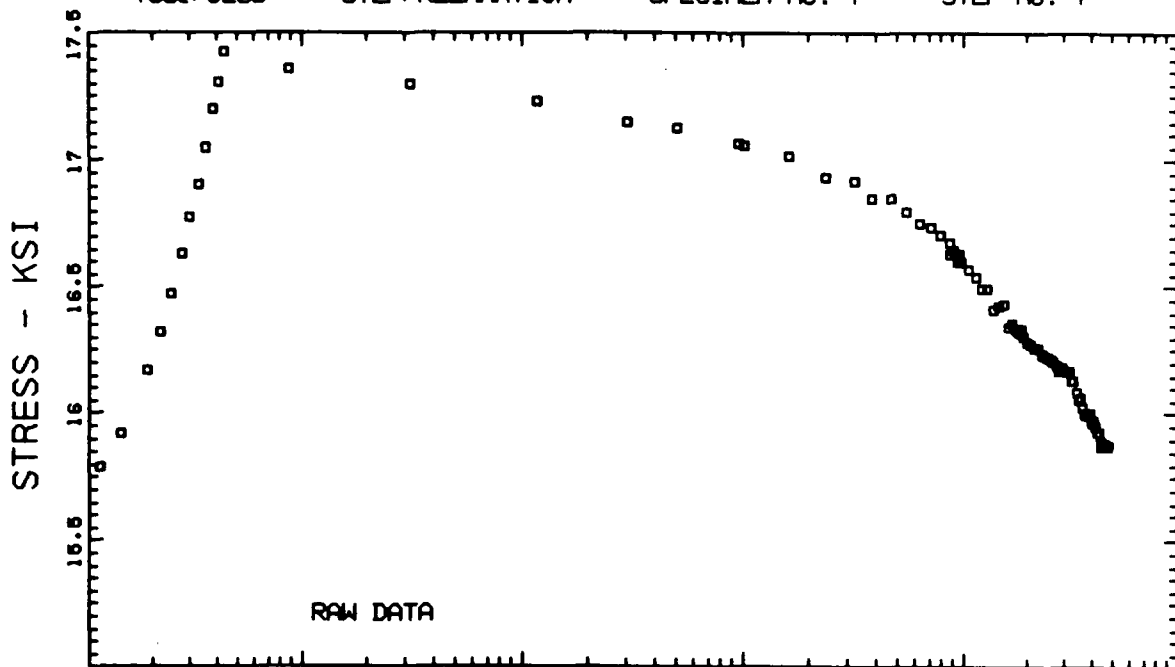

T300/5208 - STEP/RELAXATION - SPECIMEN No. 7 - STEP No. 7

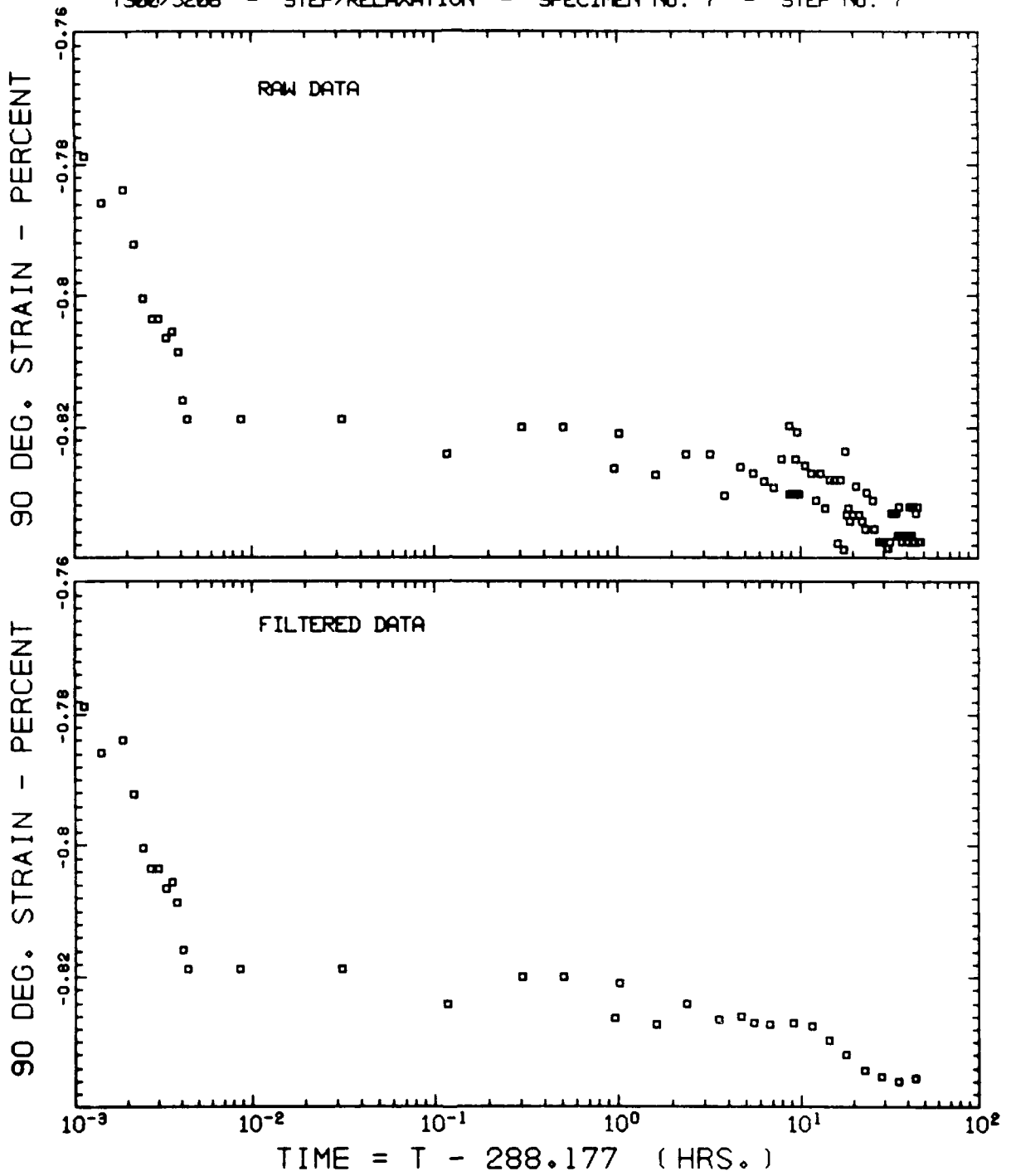

T300/5208 - STEP/RELAXATION - SPECIMEN No. 7 - STEP No. 7

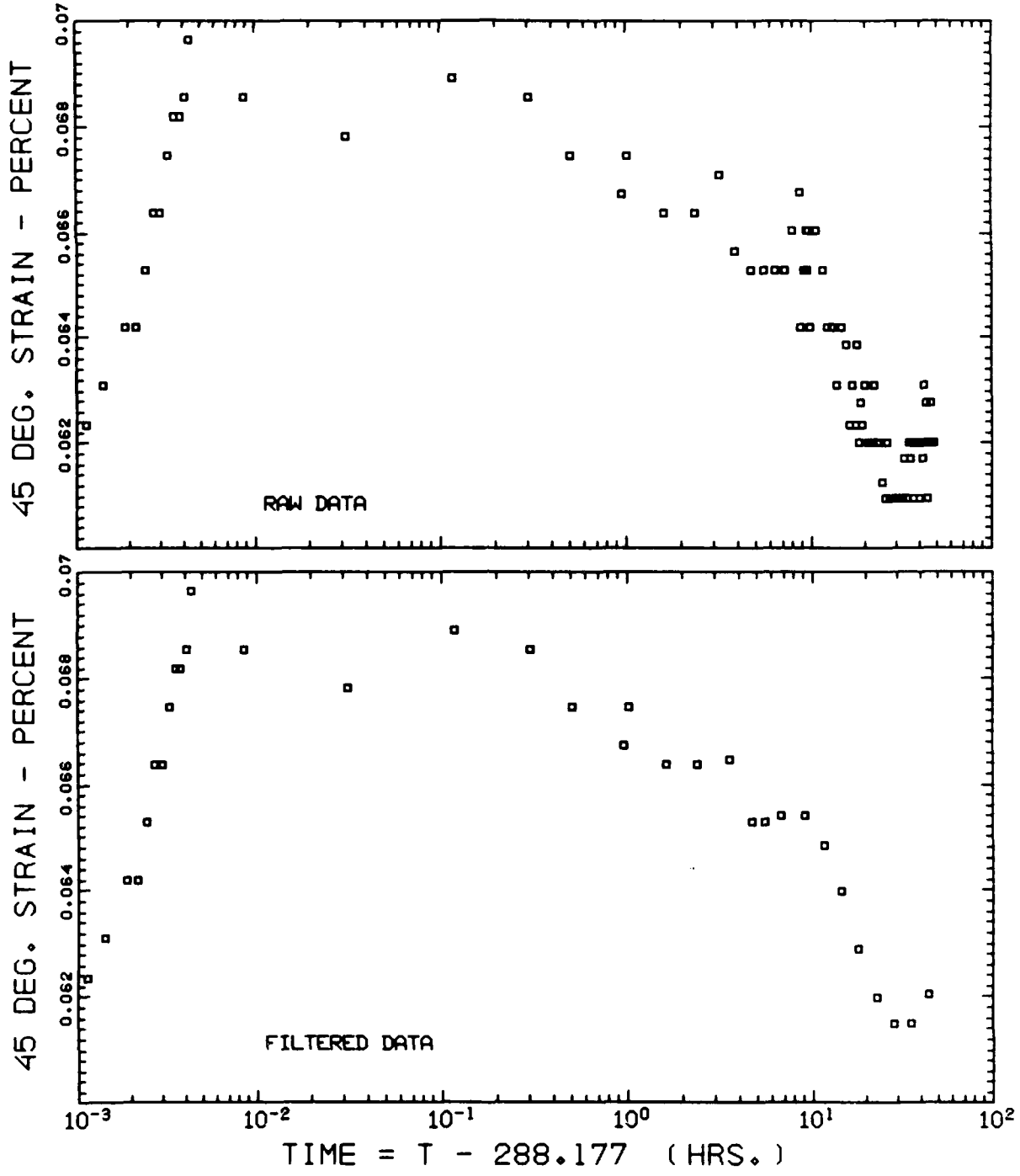

T300/S208 - STEP/RELAXATION - SPECIMEN No. 7 - STEP No. 8

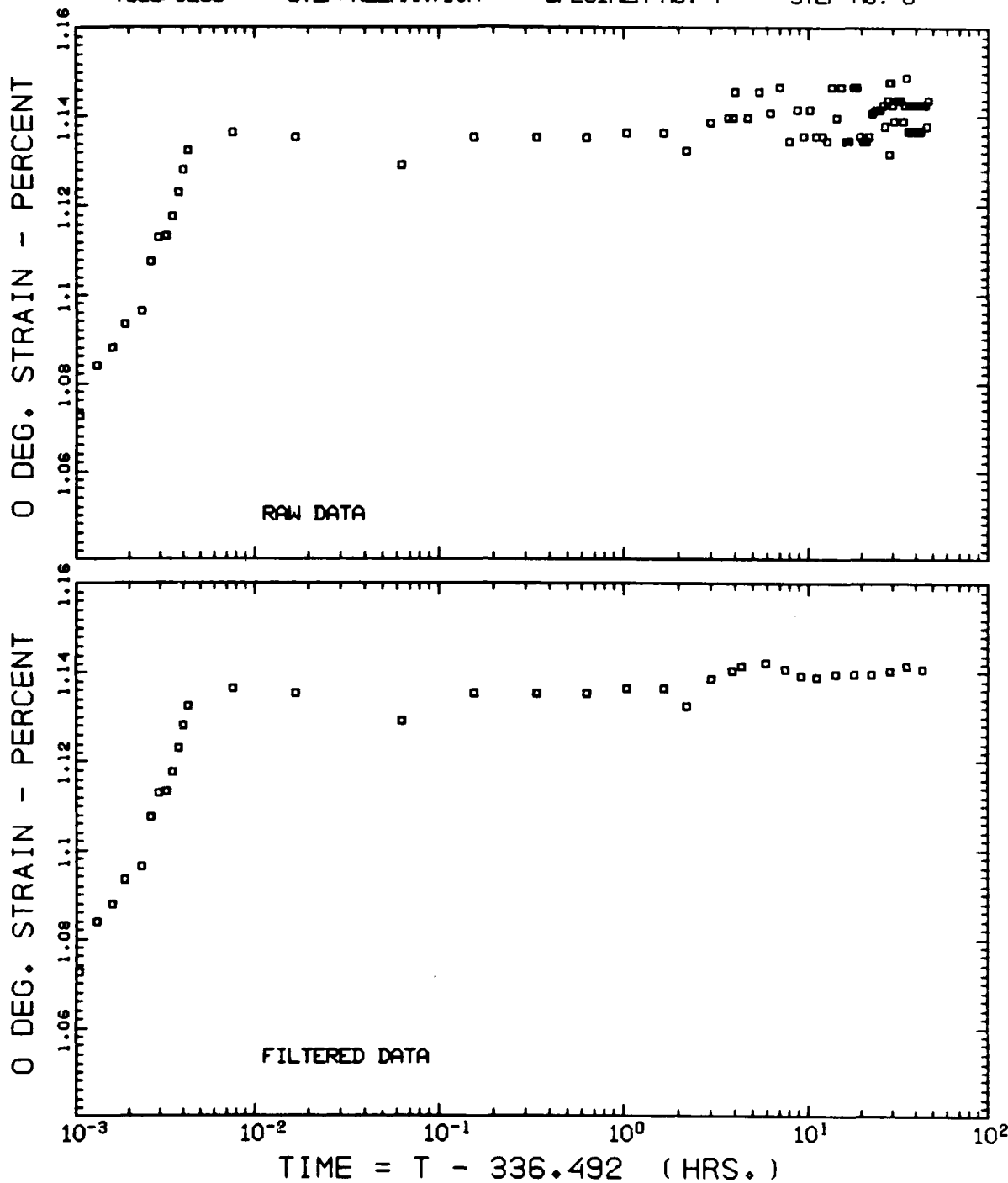

T300/5208 - STEP/RELAXATION - SPECIMEN No. 7 - STEP No. 8

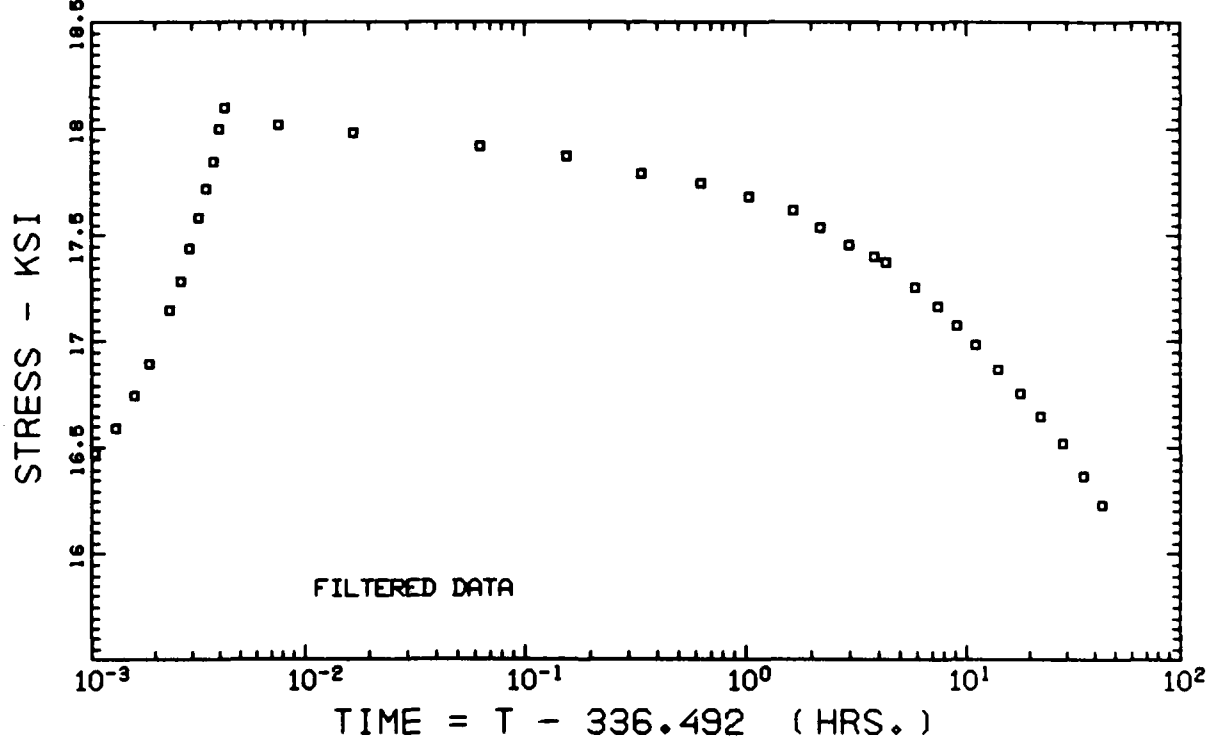
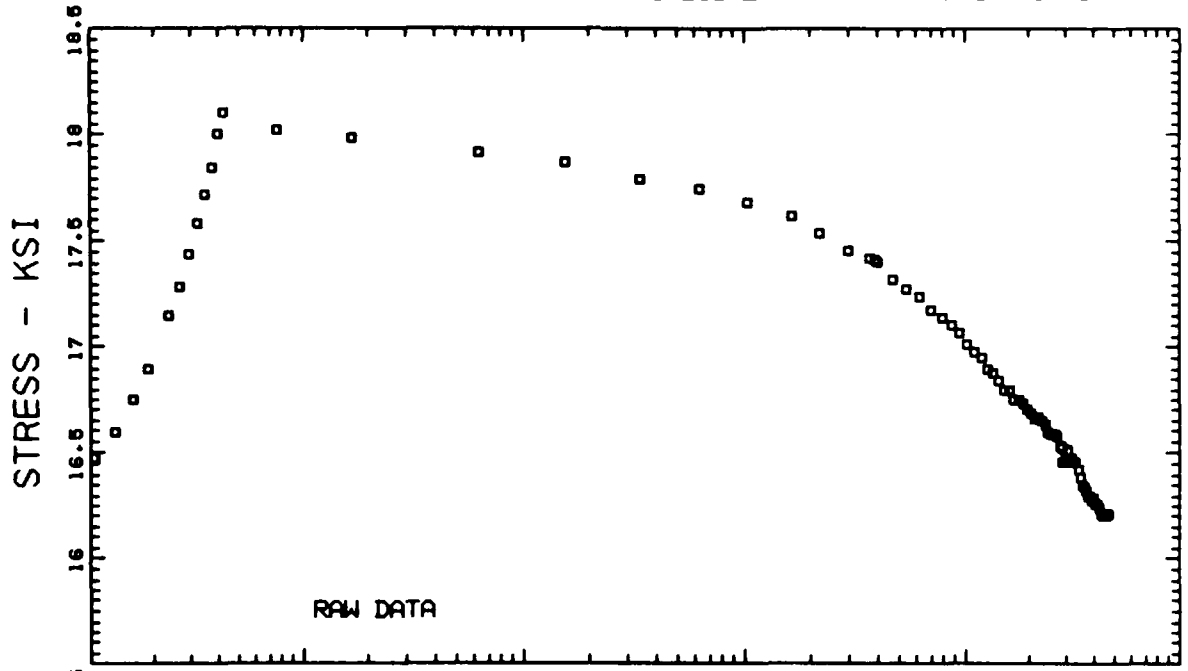

T300/5208 - STEP/RELAXATION - SPECIMEN No. 7 - STEP No. 8

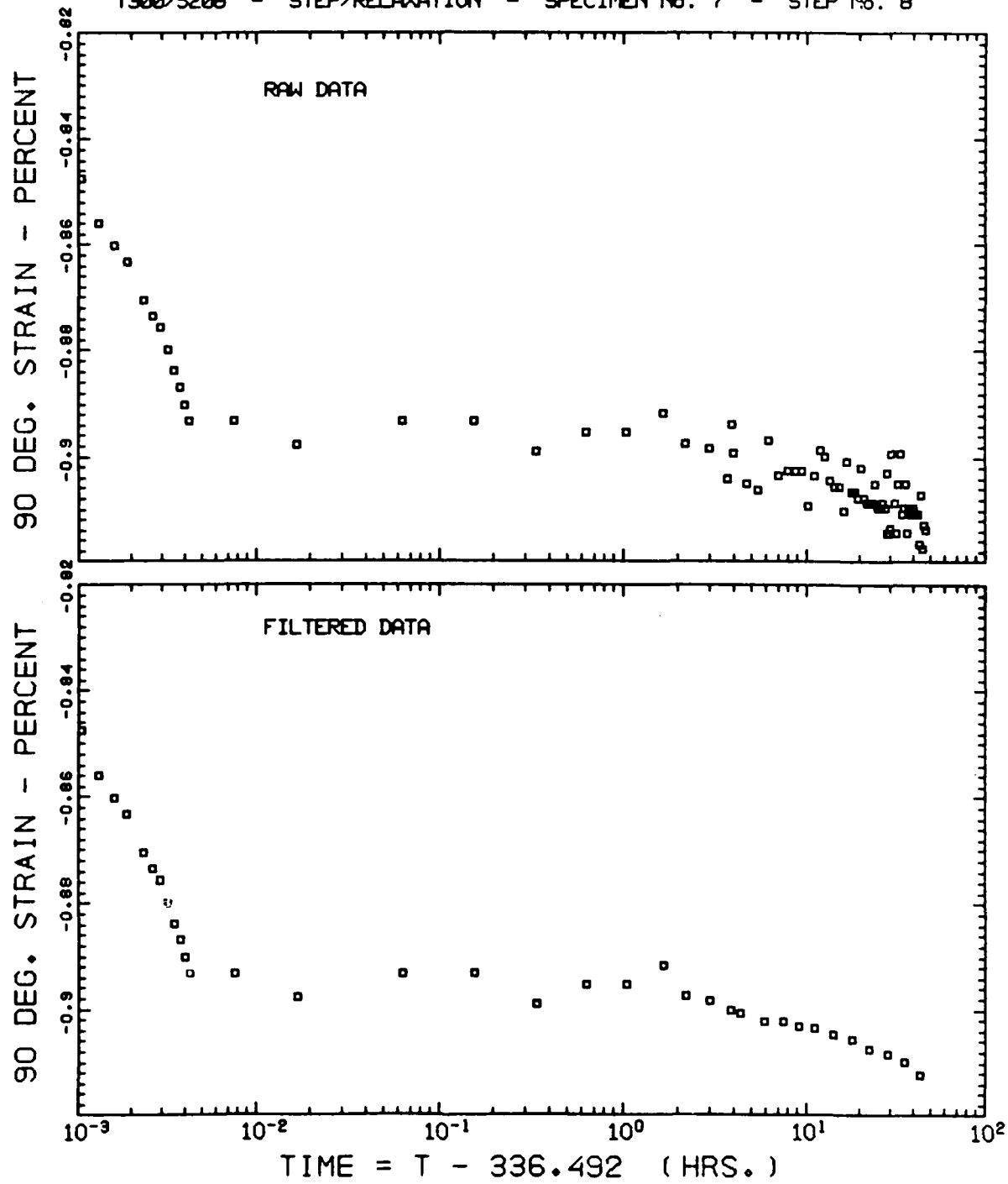



T300/5208 - STEP/RELAXATION - SPECIMEN No. 7 - STEP No. 8

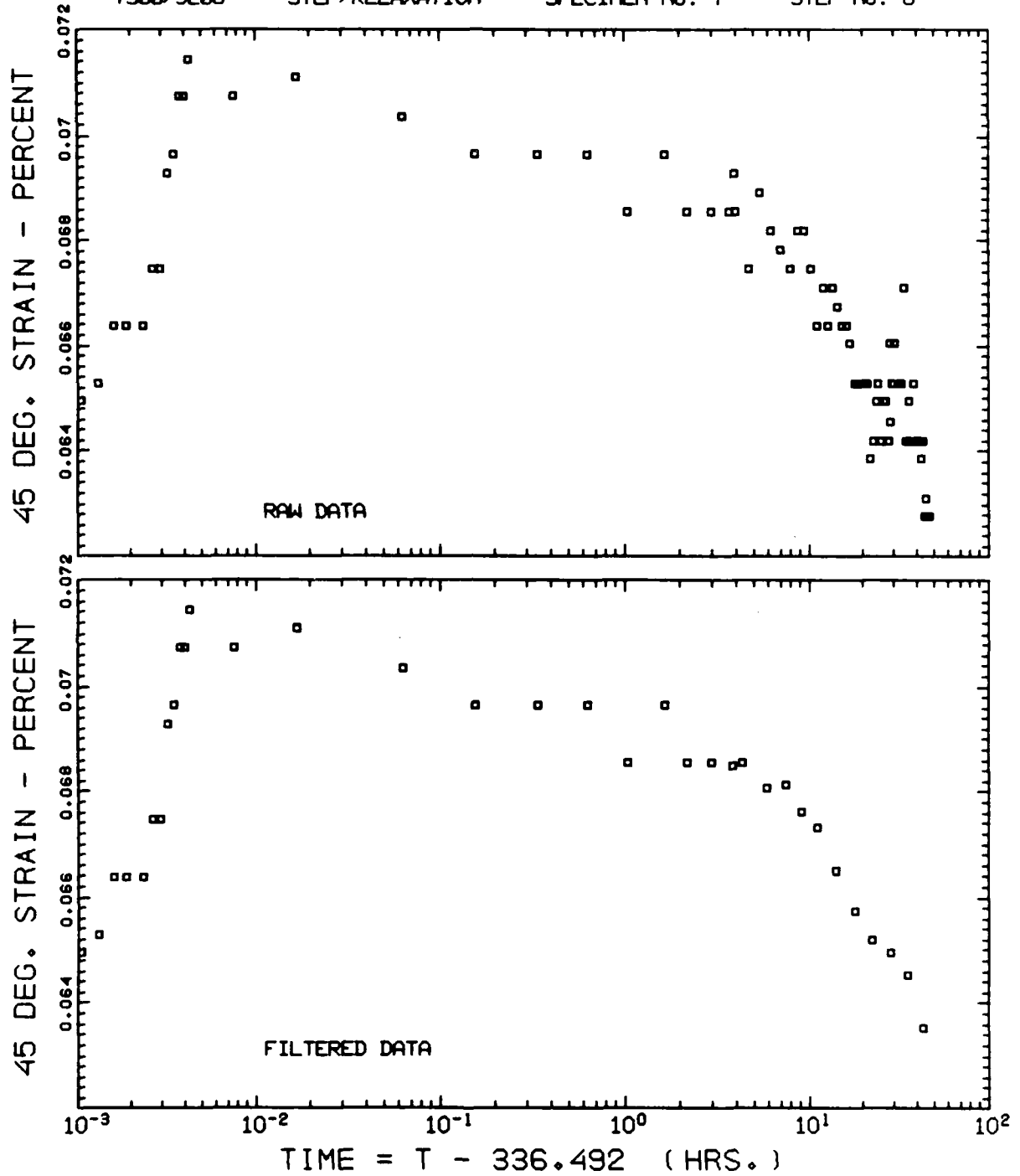

T300/5208 - STEP/RELAXATION - SPECIMEN No. 7 - STEP No. 9

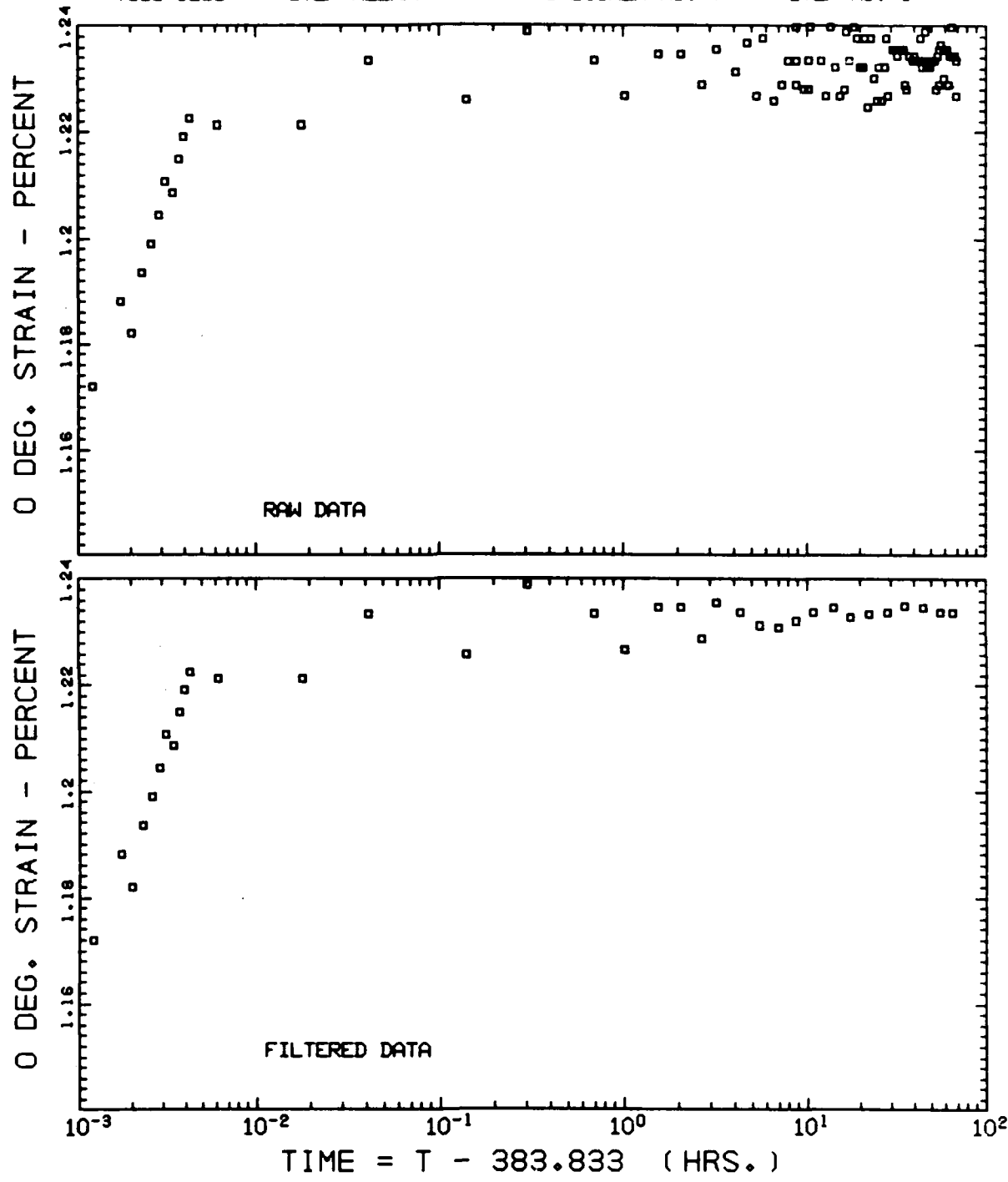

T300/5208 - STEP/RELAXATION - SPECIMEN No. 7 - STEP No. 9

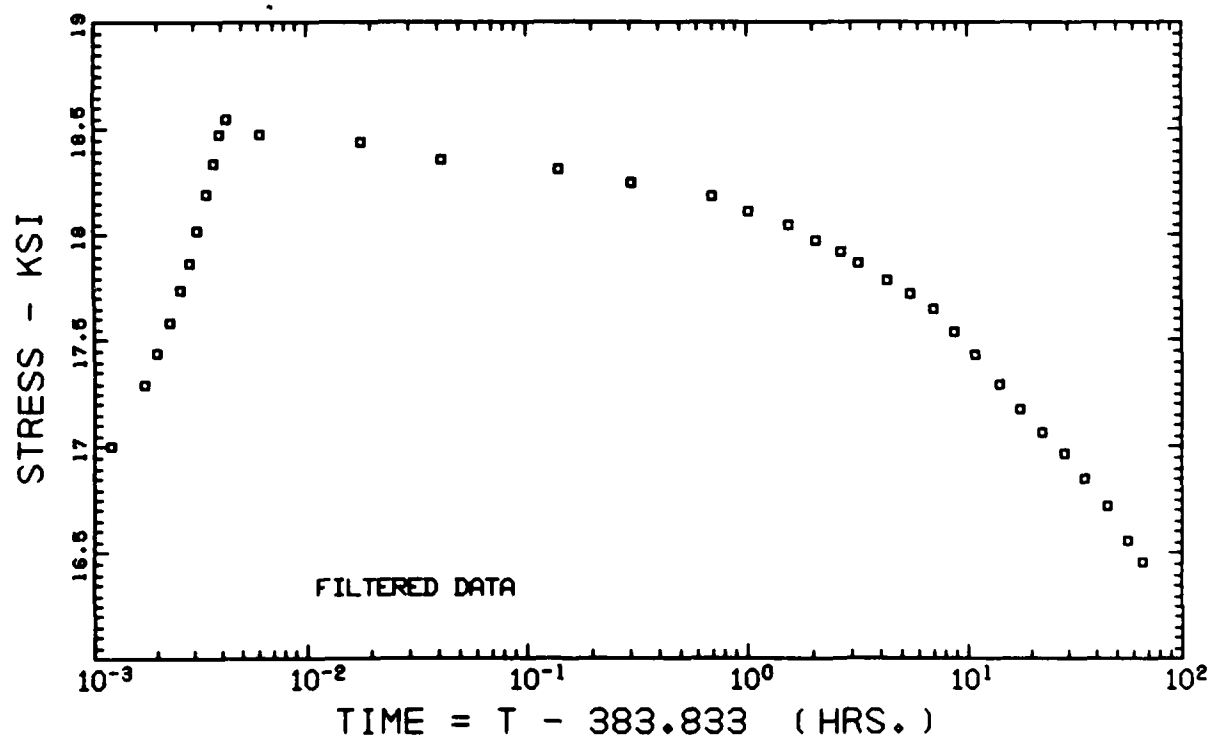
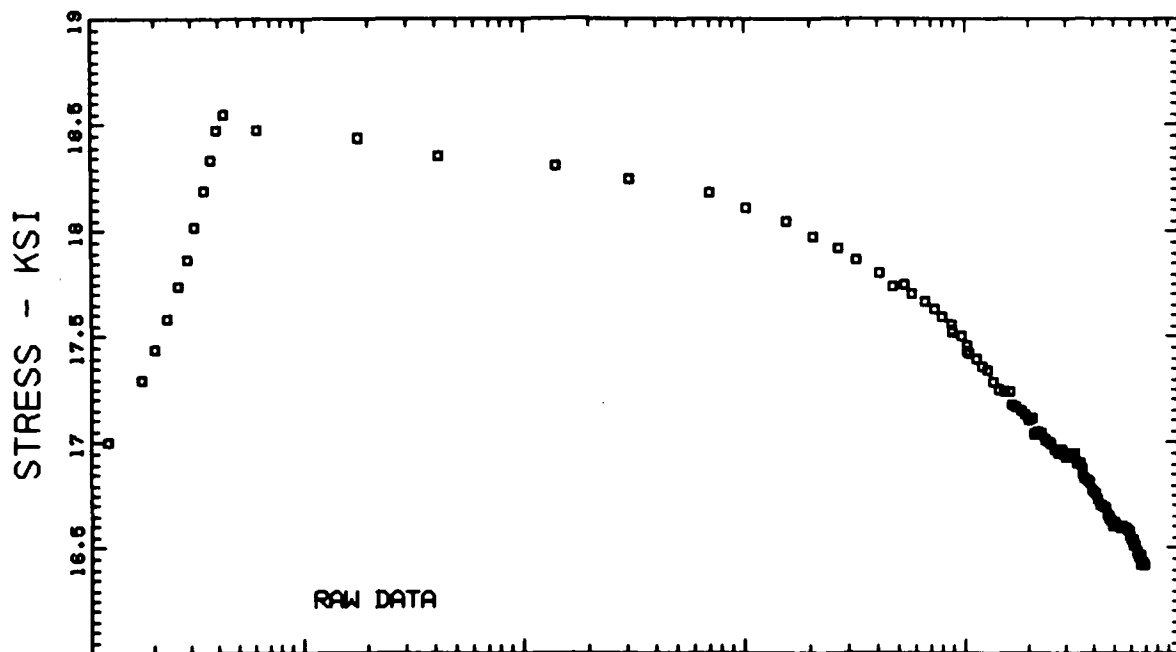

T300/5208 - STEP/RELAXATION - SPECIMEN No. 7 - STEP No. 9

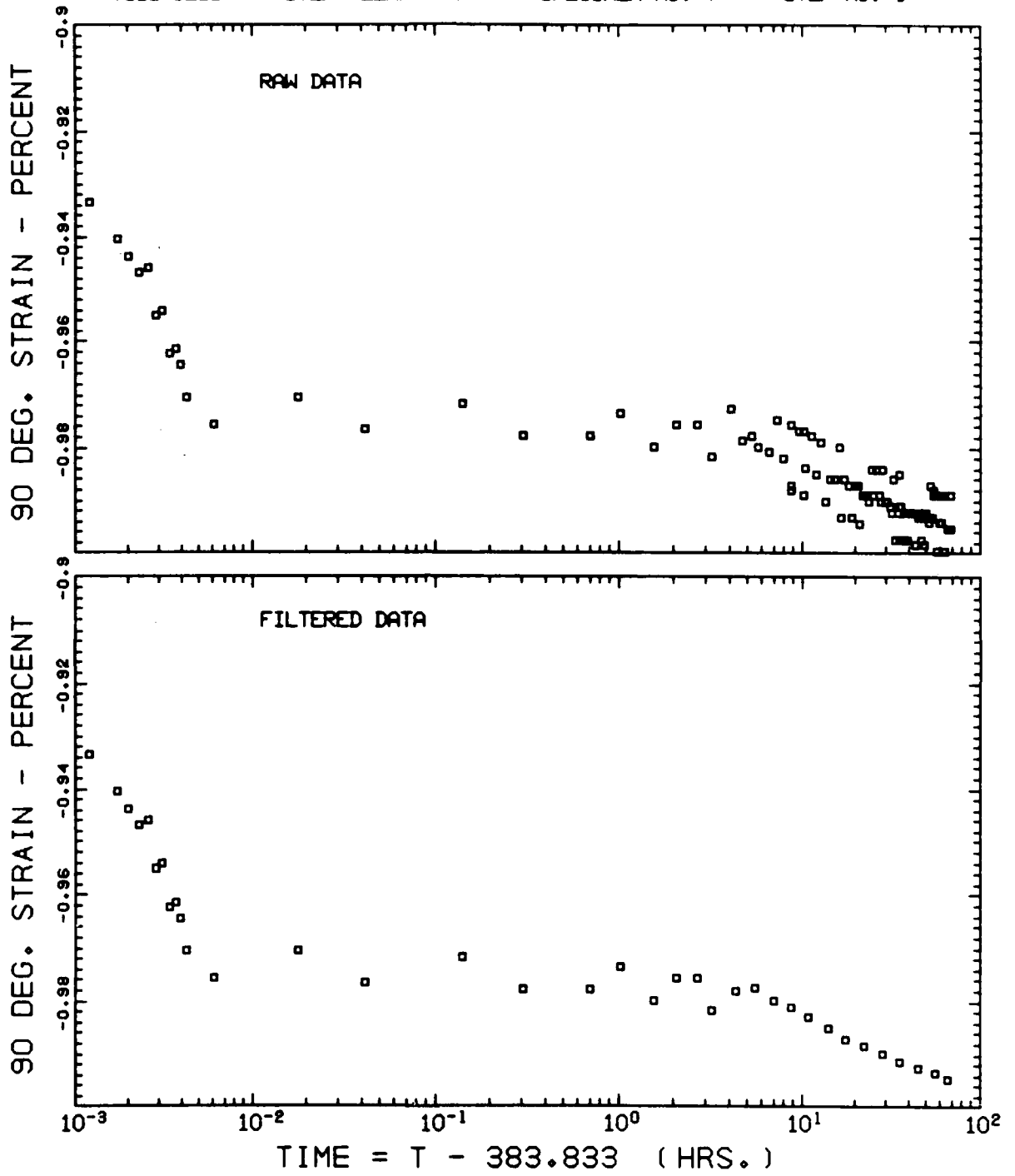

T300/5208 - STEP/RELAXATION - SPECIMEN No. 7 - STEP No. 9

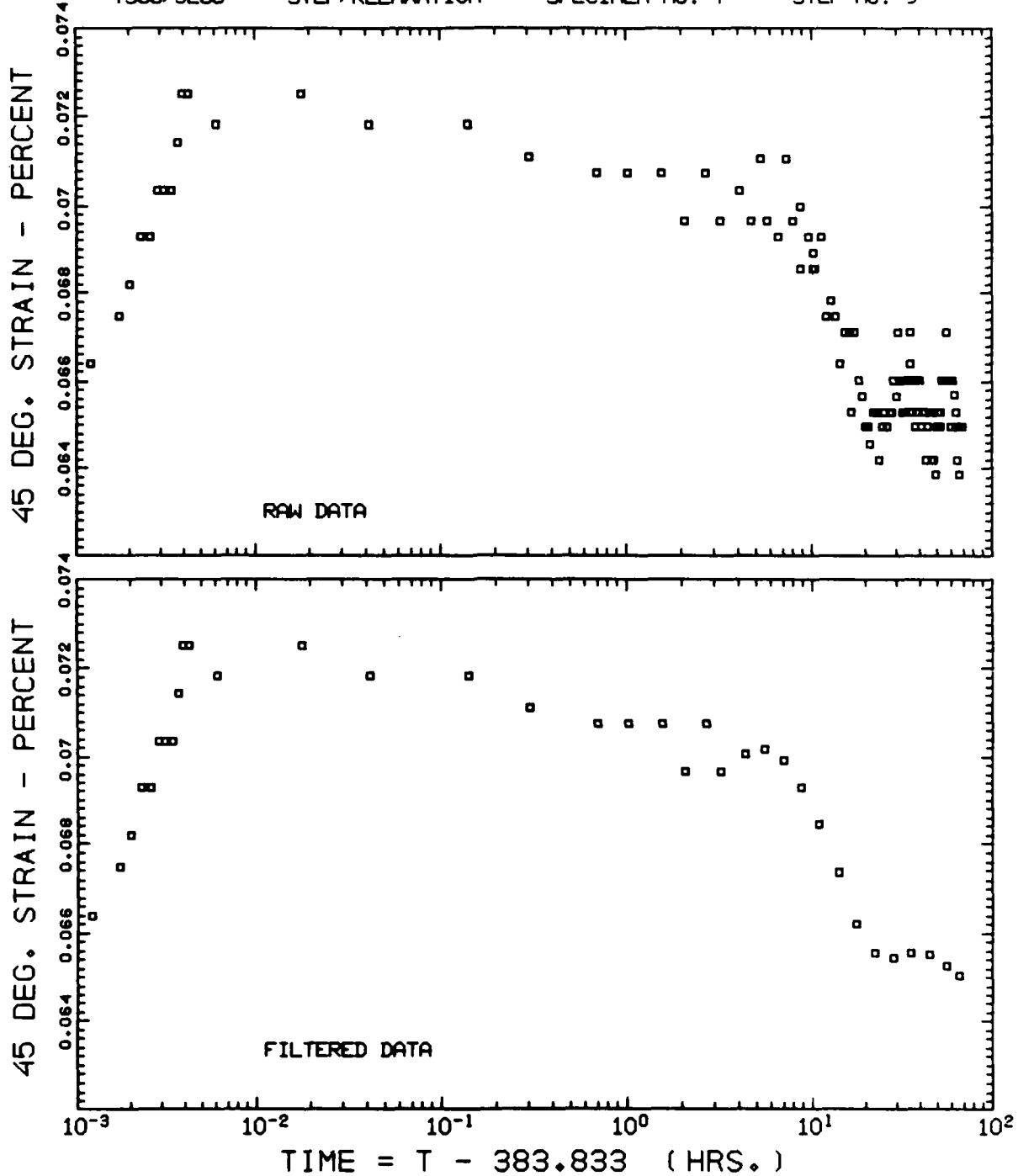

T300/5208 - STEP/RELAXATION - SPECIMEN No. 7 - STEP No. 10

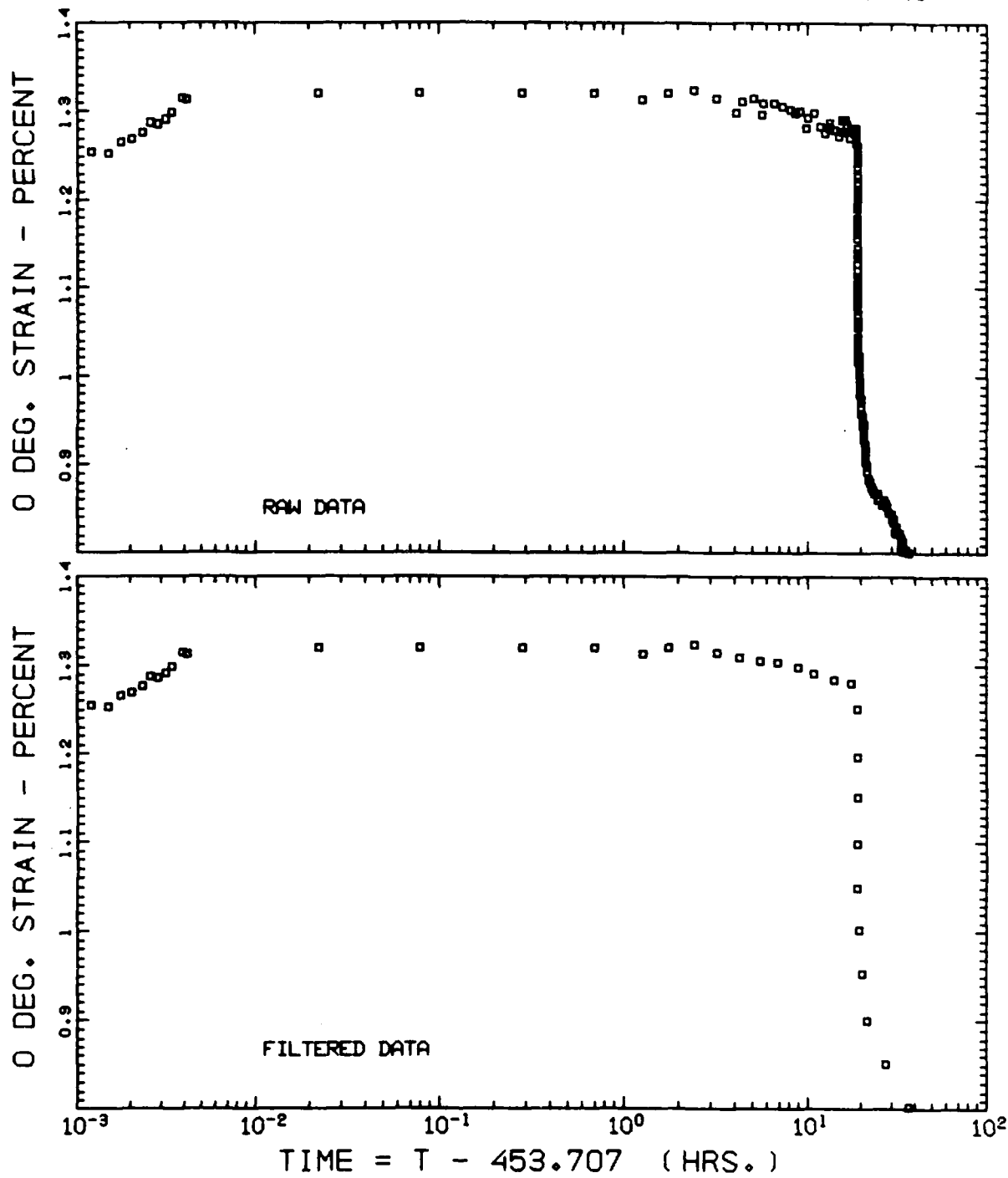

T300/5208 - STEP/RELAXATION - SPECIMEN No. 7 - STEP No. 10

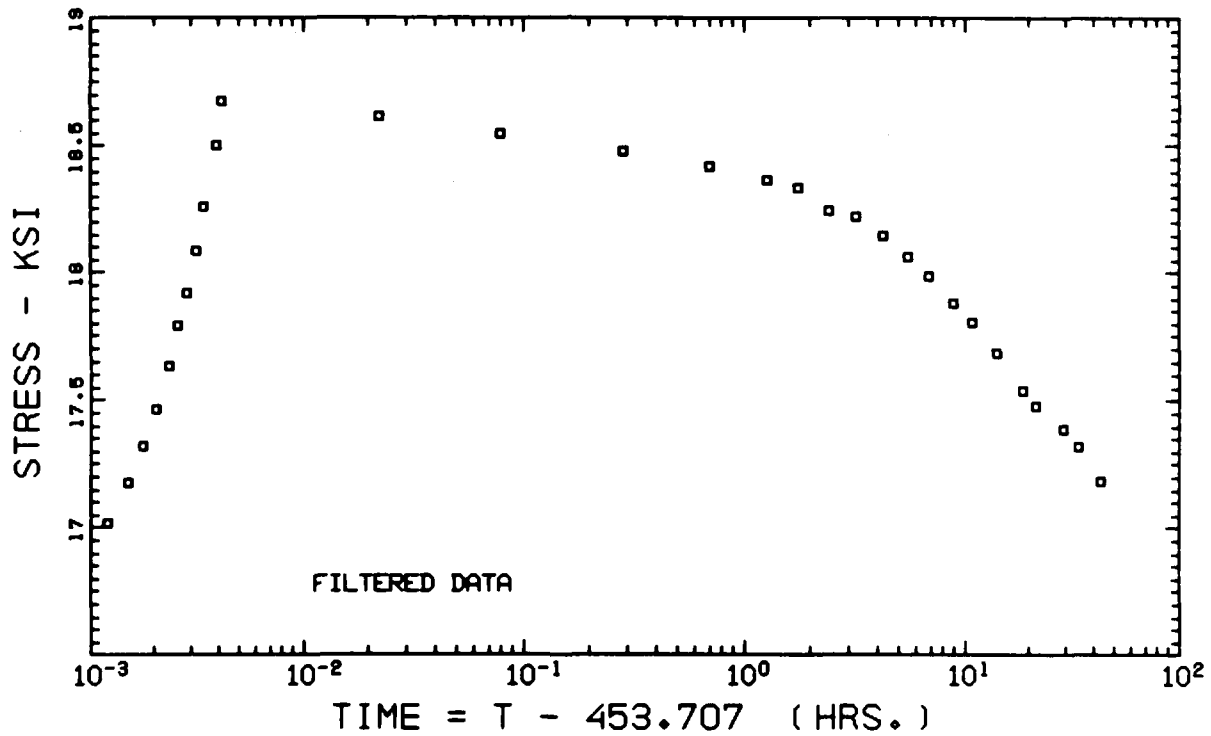
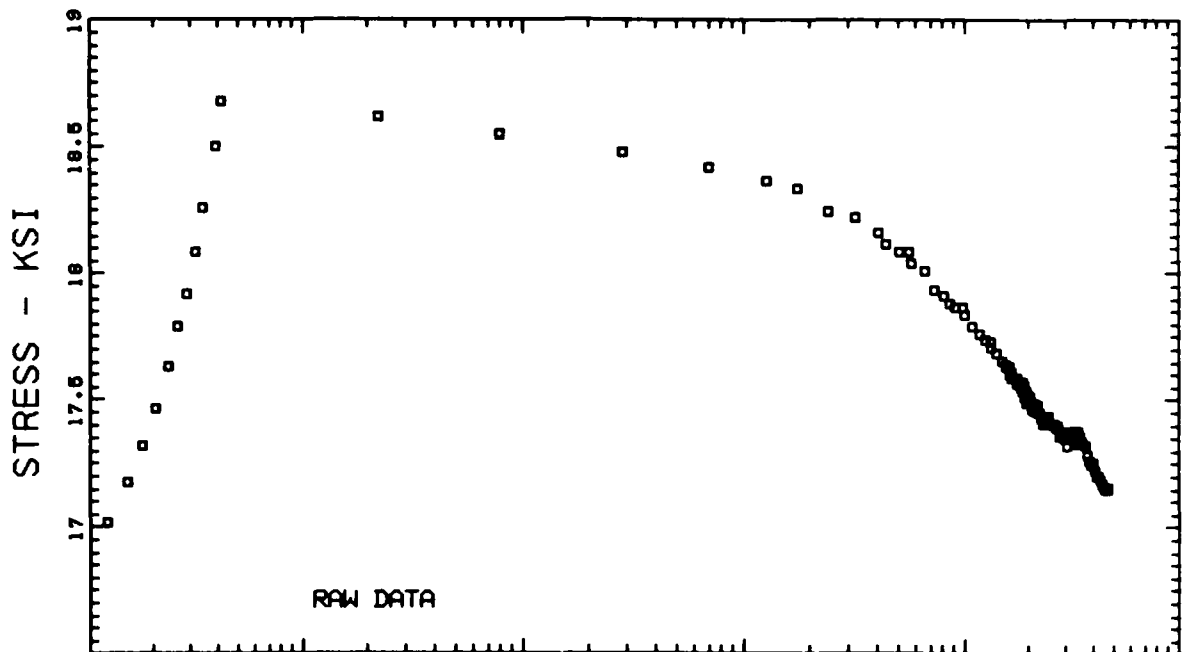

T300/5208 - STEP/RELAXATION - SPECIMEN No. 7 - STEP No. 10

90 DEG. STRAIN - PERCENT

90 DEG. STRAIN - PERCENT

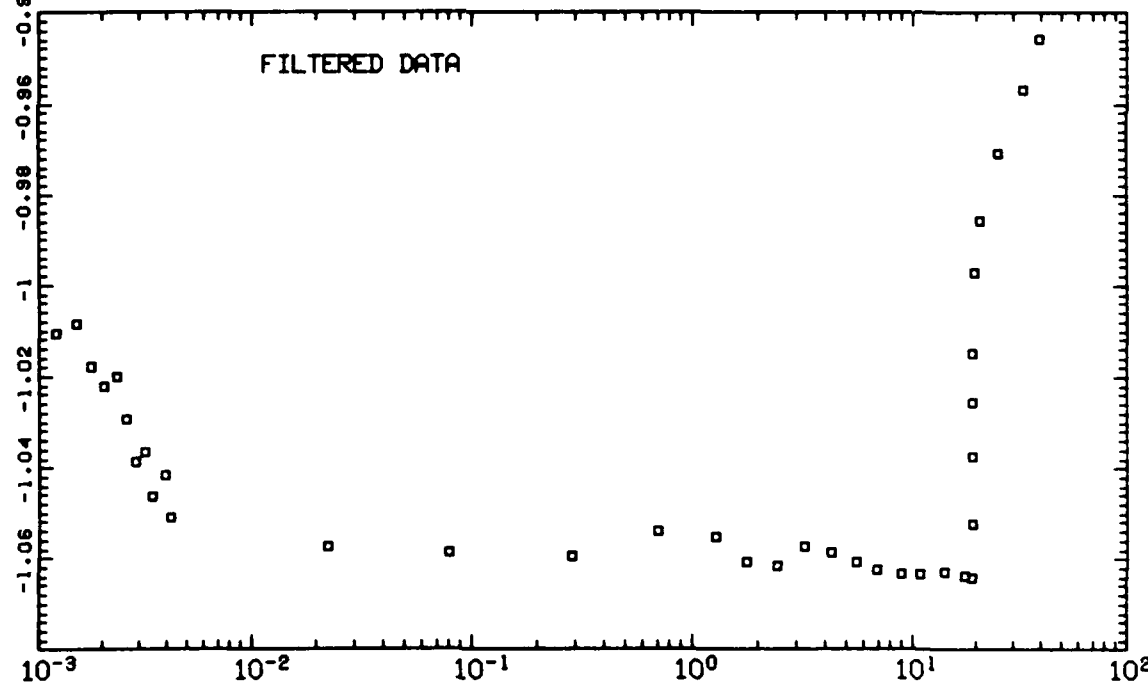
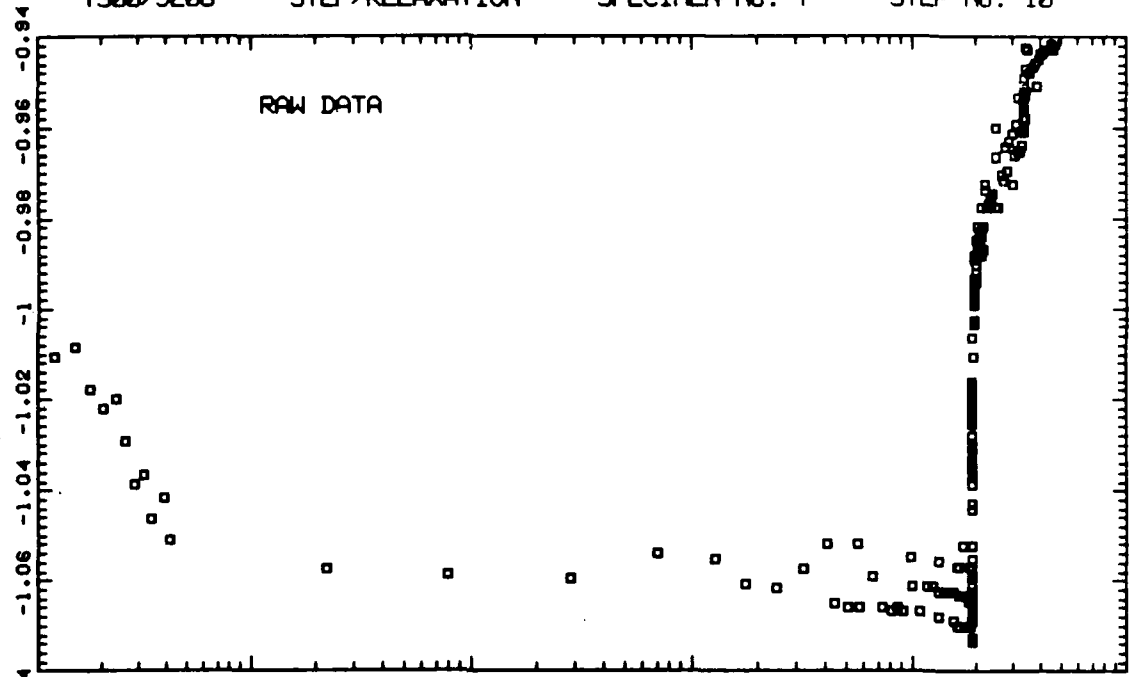

TIME = T - 453.707 (HRS.)



T300/5208 - STEP/RELAXATION - SPECIMEN No. 7 - STEP No. 10

45 DEG. STRAIN - PERCENT

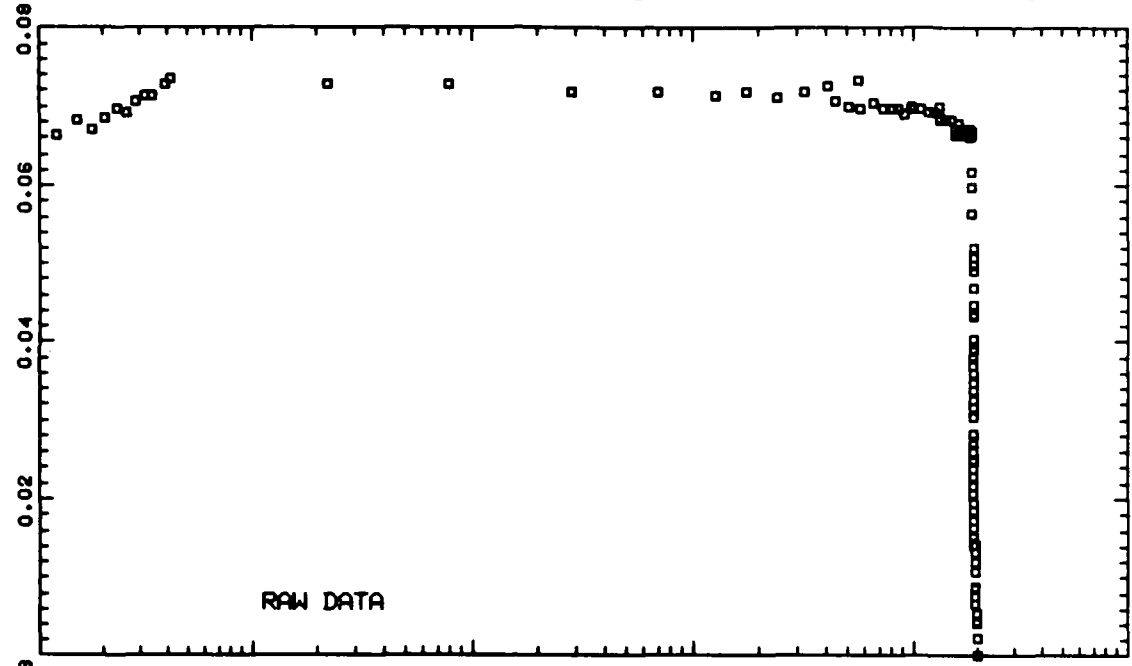

45 DEG. STRAIN - PERCENT

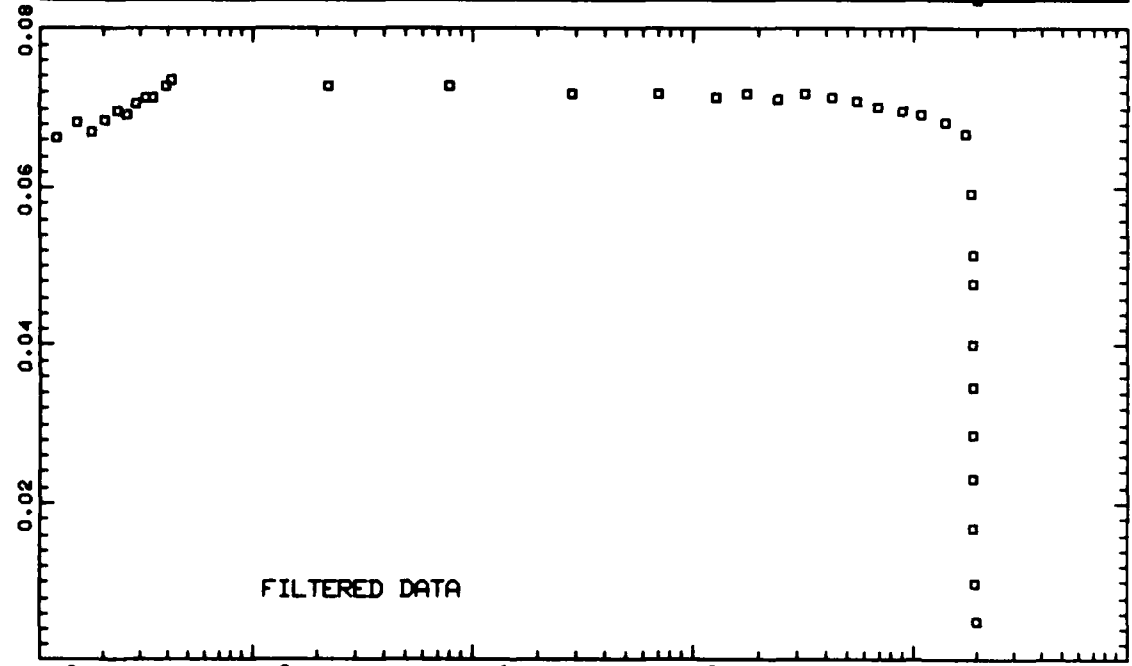

TIME = T - 453.707 (HRS.)

T300/5208 - STEP/RELAXATION - SPECIMEN No. 7 - STEP No. 11

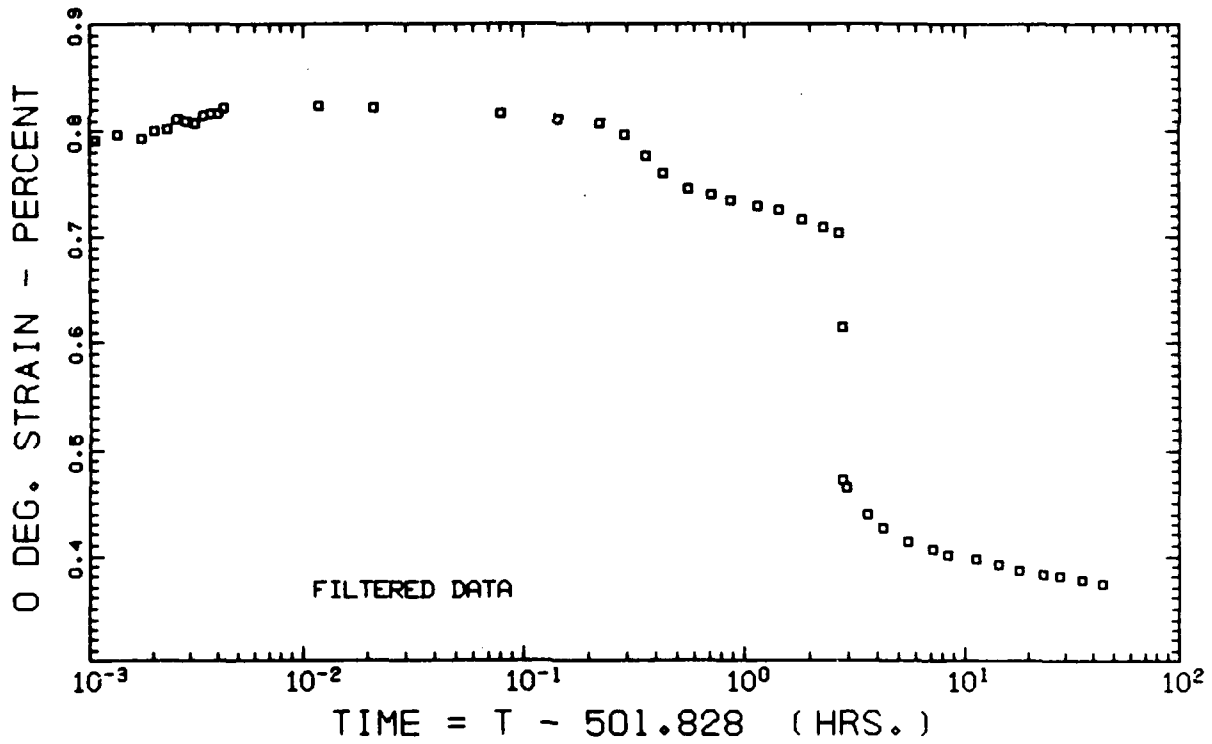
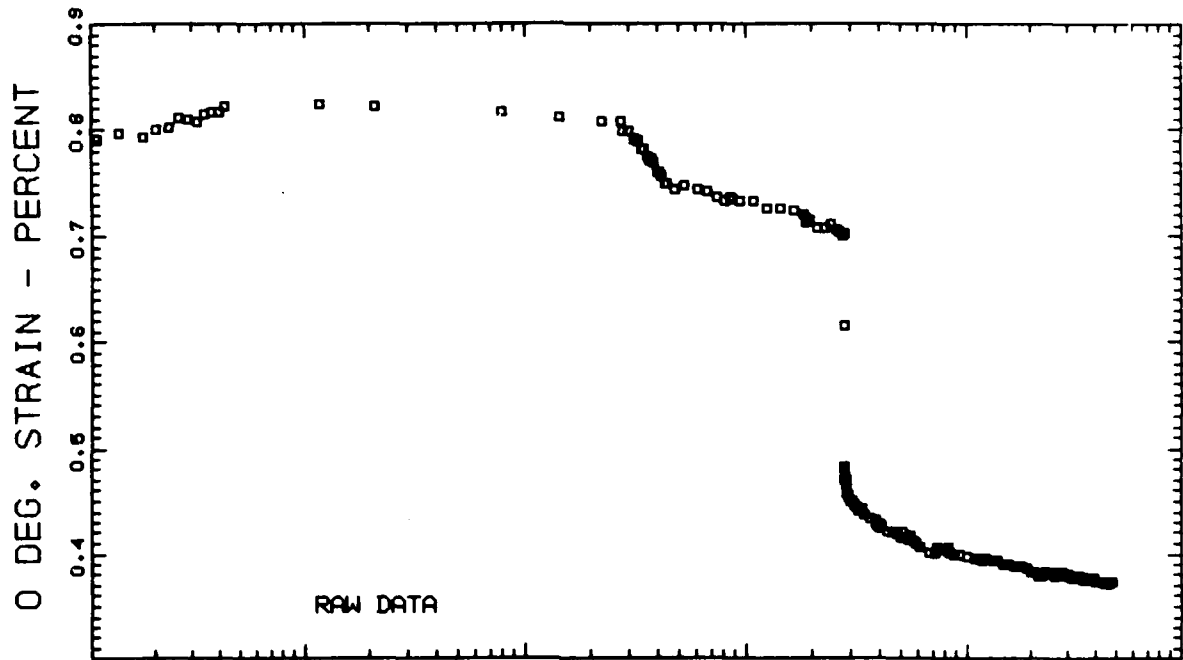

T300/5208 - STEP/RELAXATION - SPECIMEN No. 7 - STEP No. 11

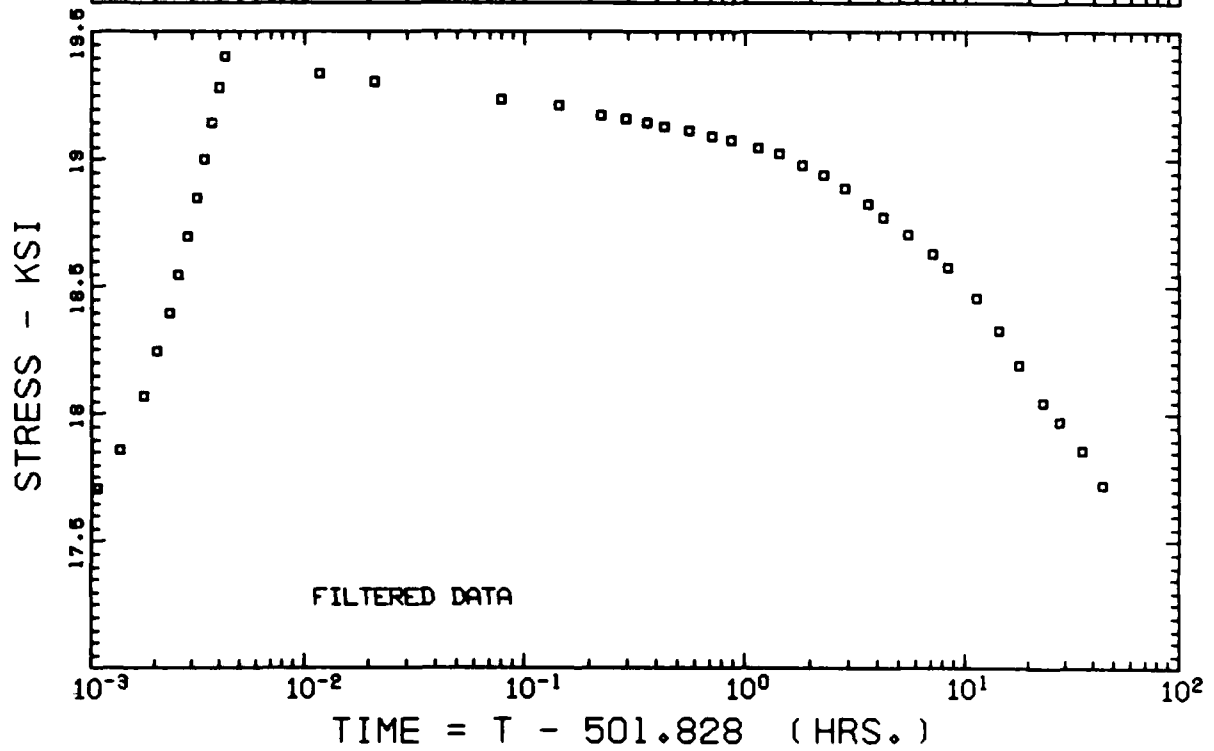
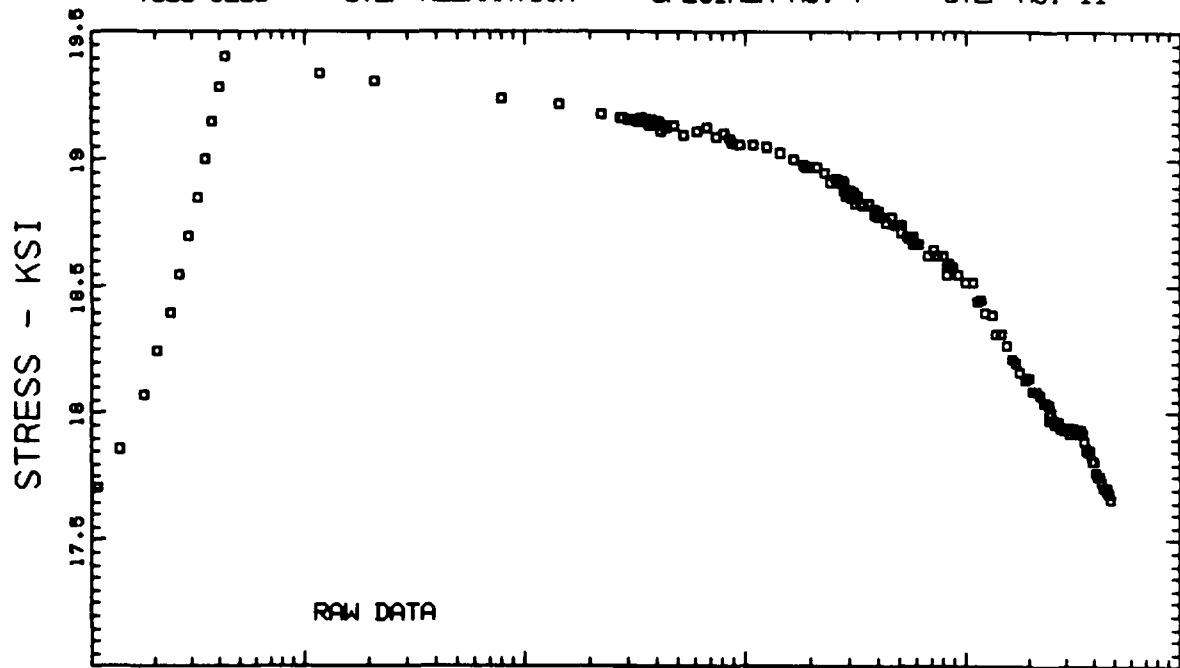

T300/5208 - STEP/RELAXATION - SPECIMEN No. 7 - STEP No. 11

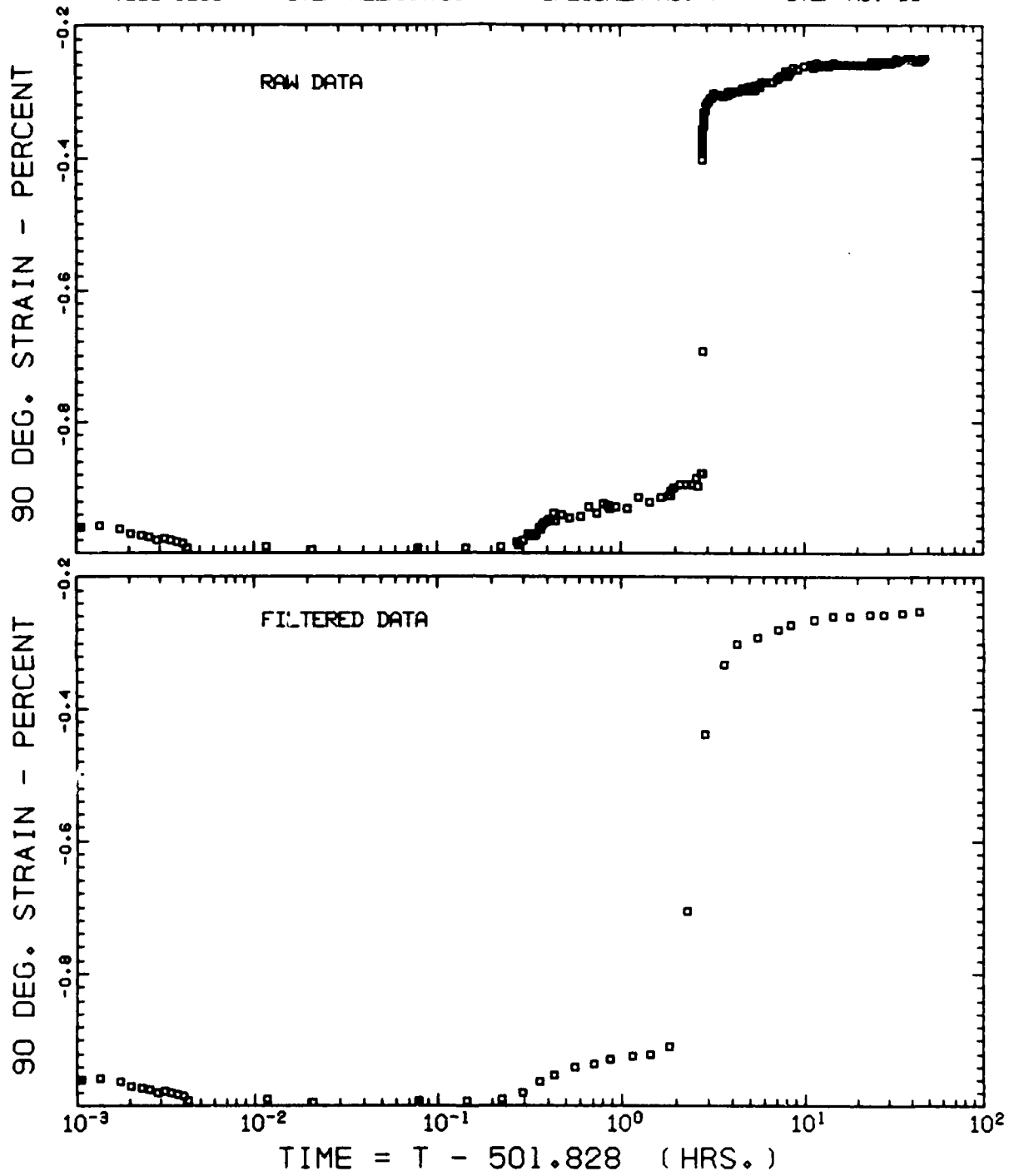

T300/5208 - STEP/RELAXATION - SPECIMEN No. 7 - STEP No. 11

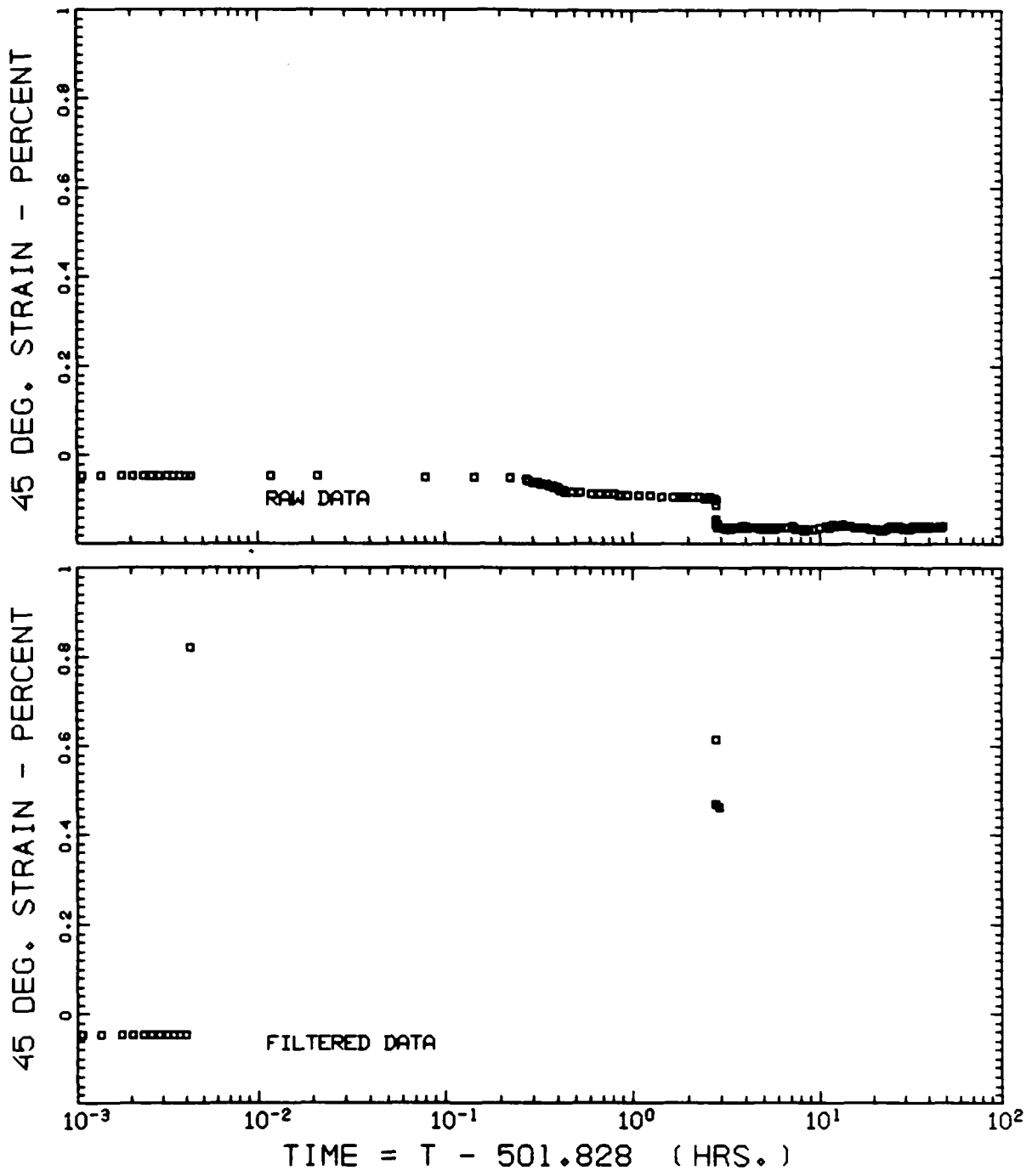

T300/5208 - STEP/RELAXATION - SPECIMEN No. 7 - STEP No. 12

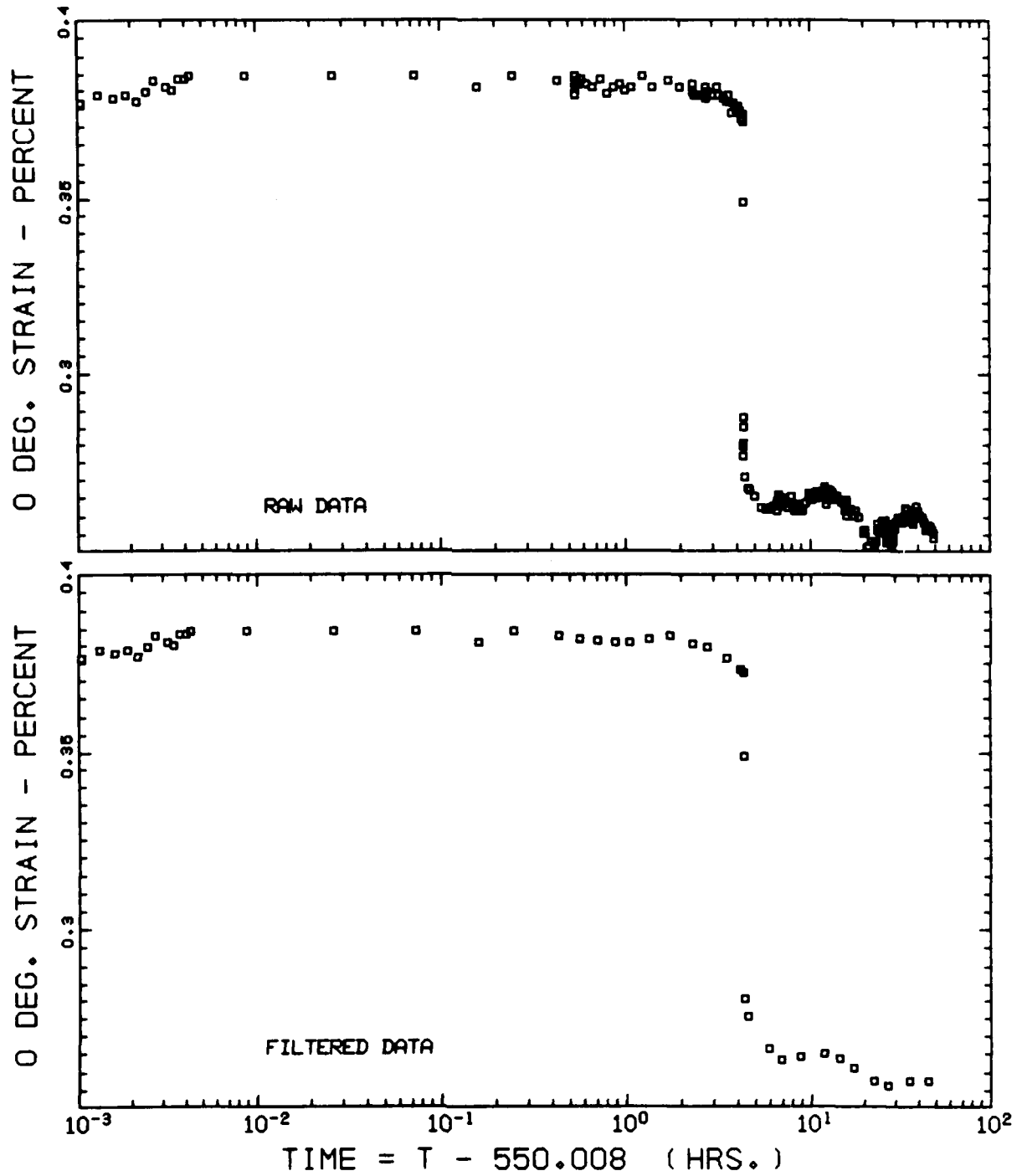

T300/5208 - STEP/RELAXATION - SPECIMEN No. 7 - STEP No. 12

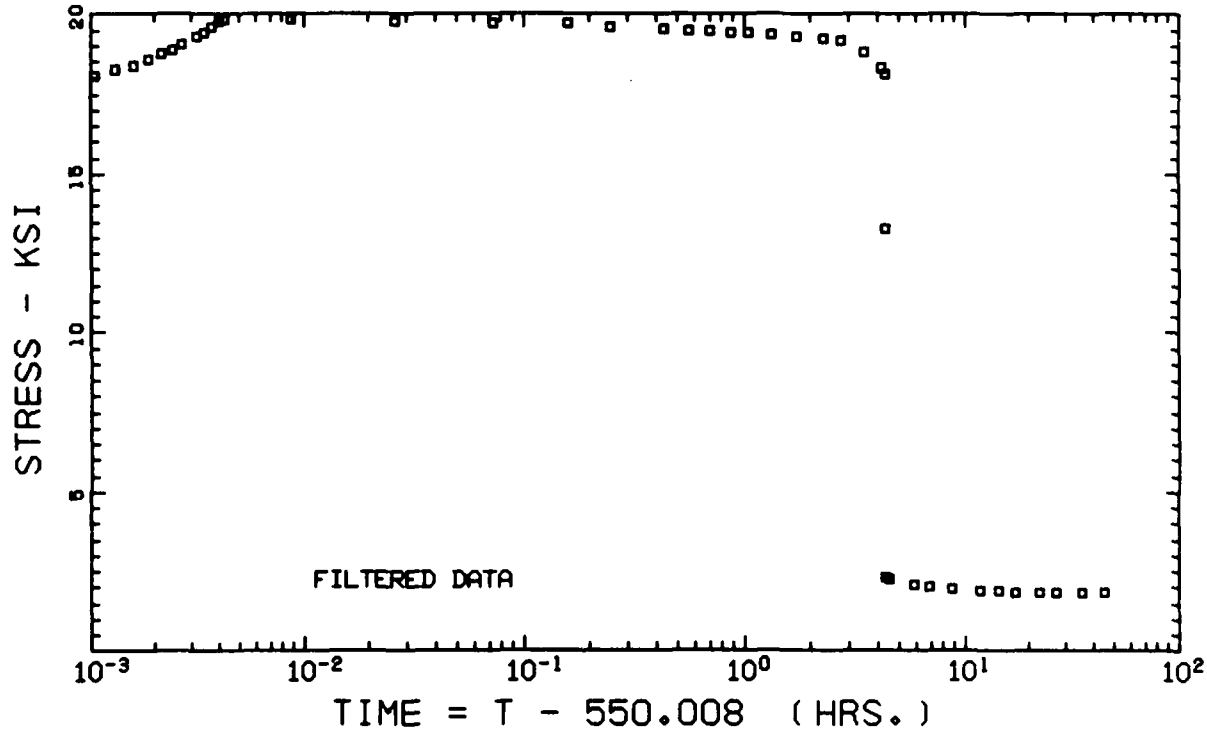
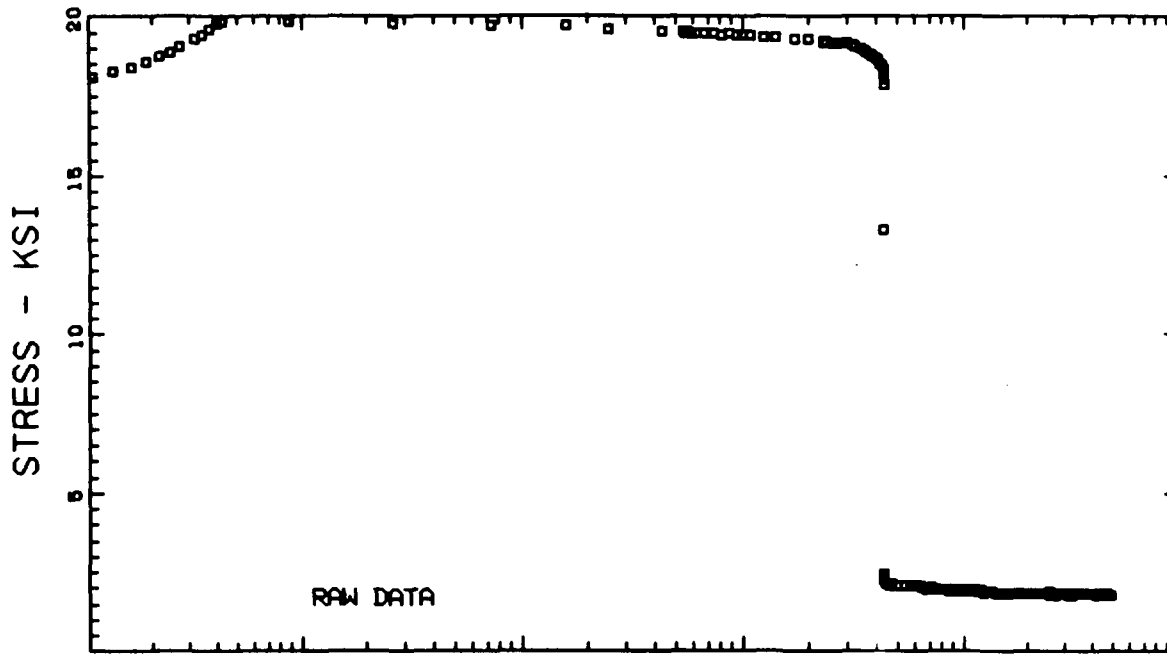

T300/S208 - STEP/RELAXATION - SPECIMEN No. 7 - STEP No. 12

90 DEG. STRAIN - PERCENT

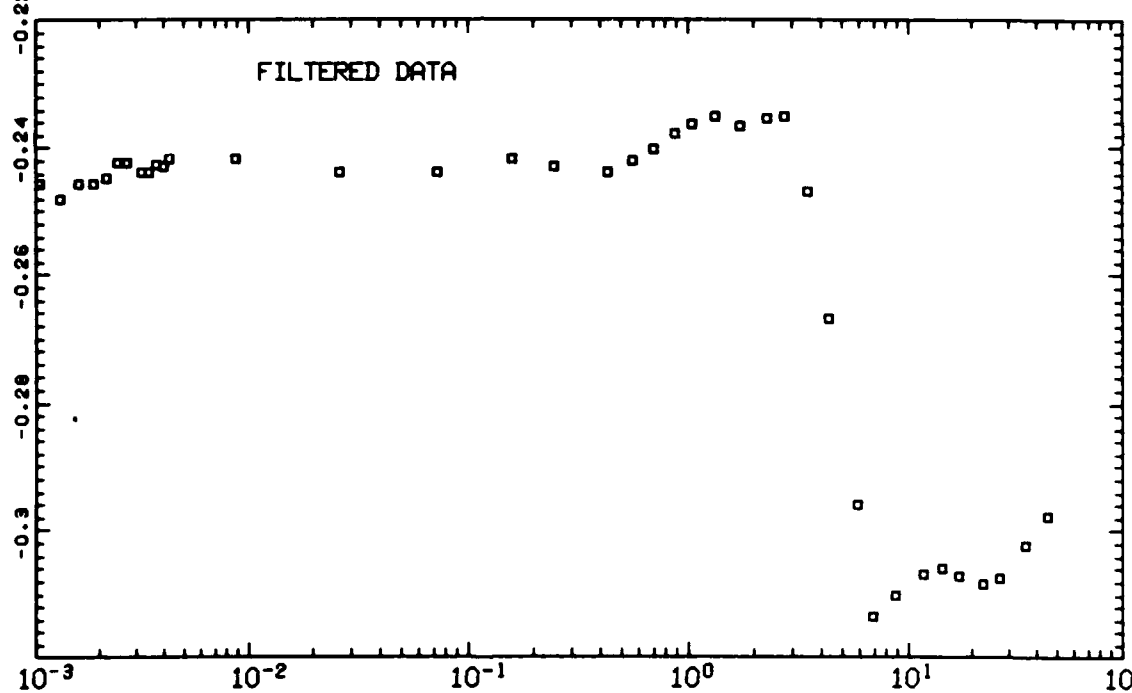
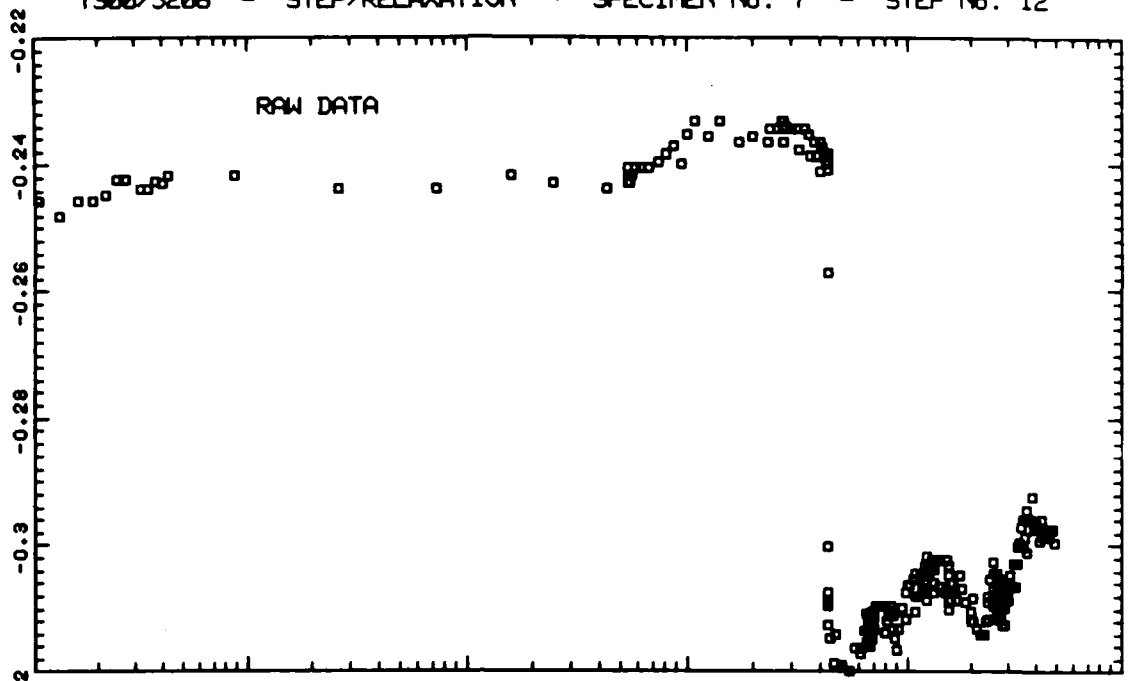

TIME = T - 550.008 (HRS.)



T300/5208 - STEP/RELAXATION - SPECIMEN No. 7 - STEP No. 12

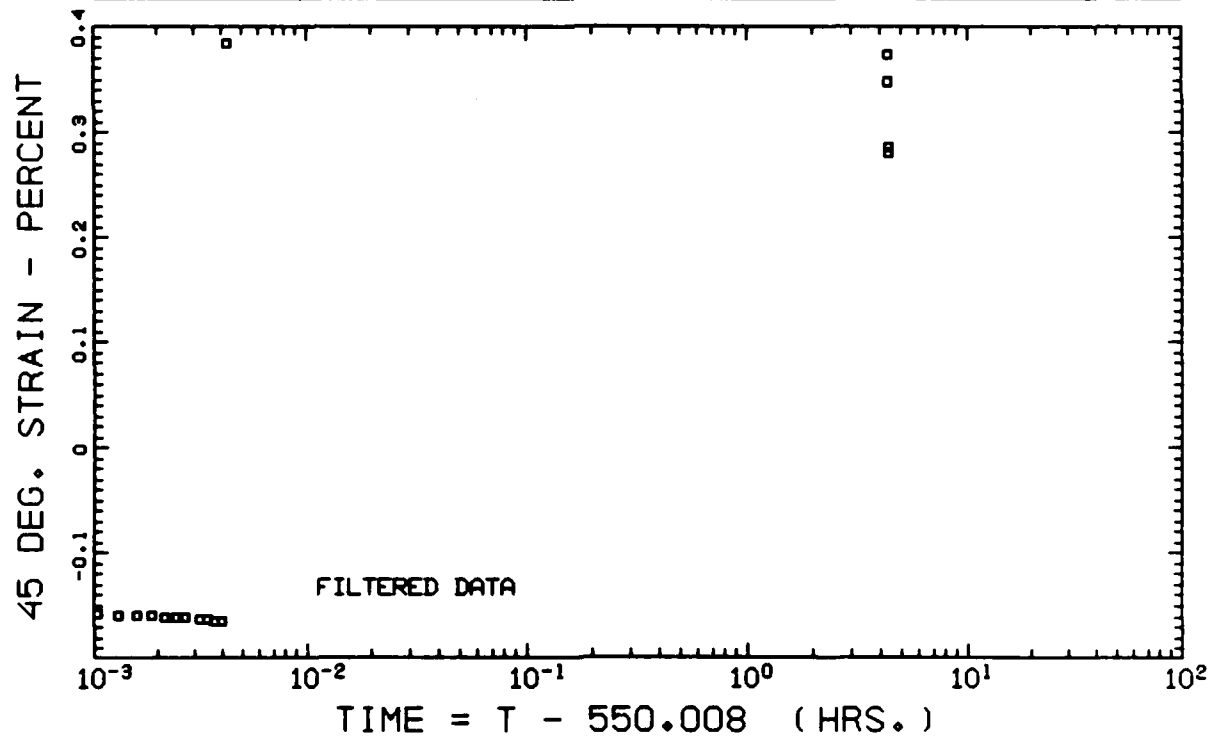
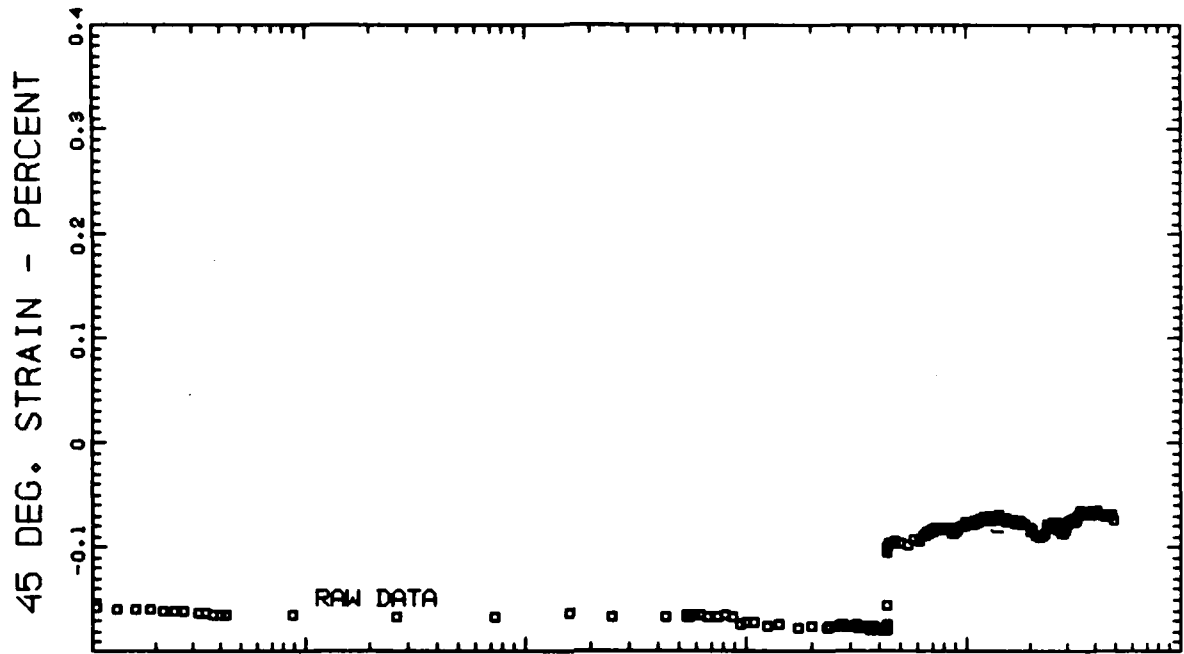

T300/5208 - STEP/RELAXATION - SPECIMEN NO. 8

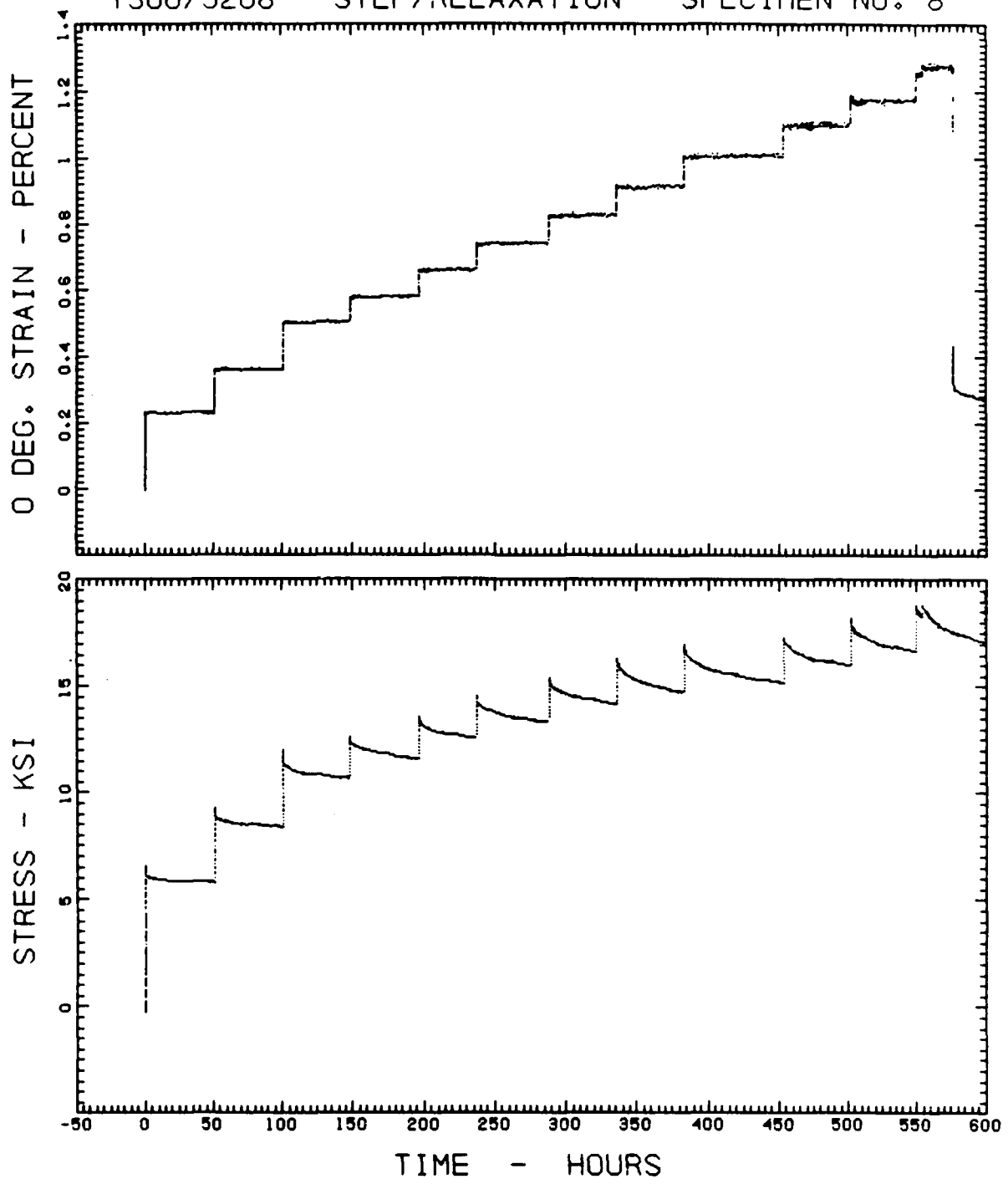

T300/5208 - STEP/RELAXATION - SPECIMEN NO. 8

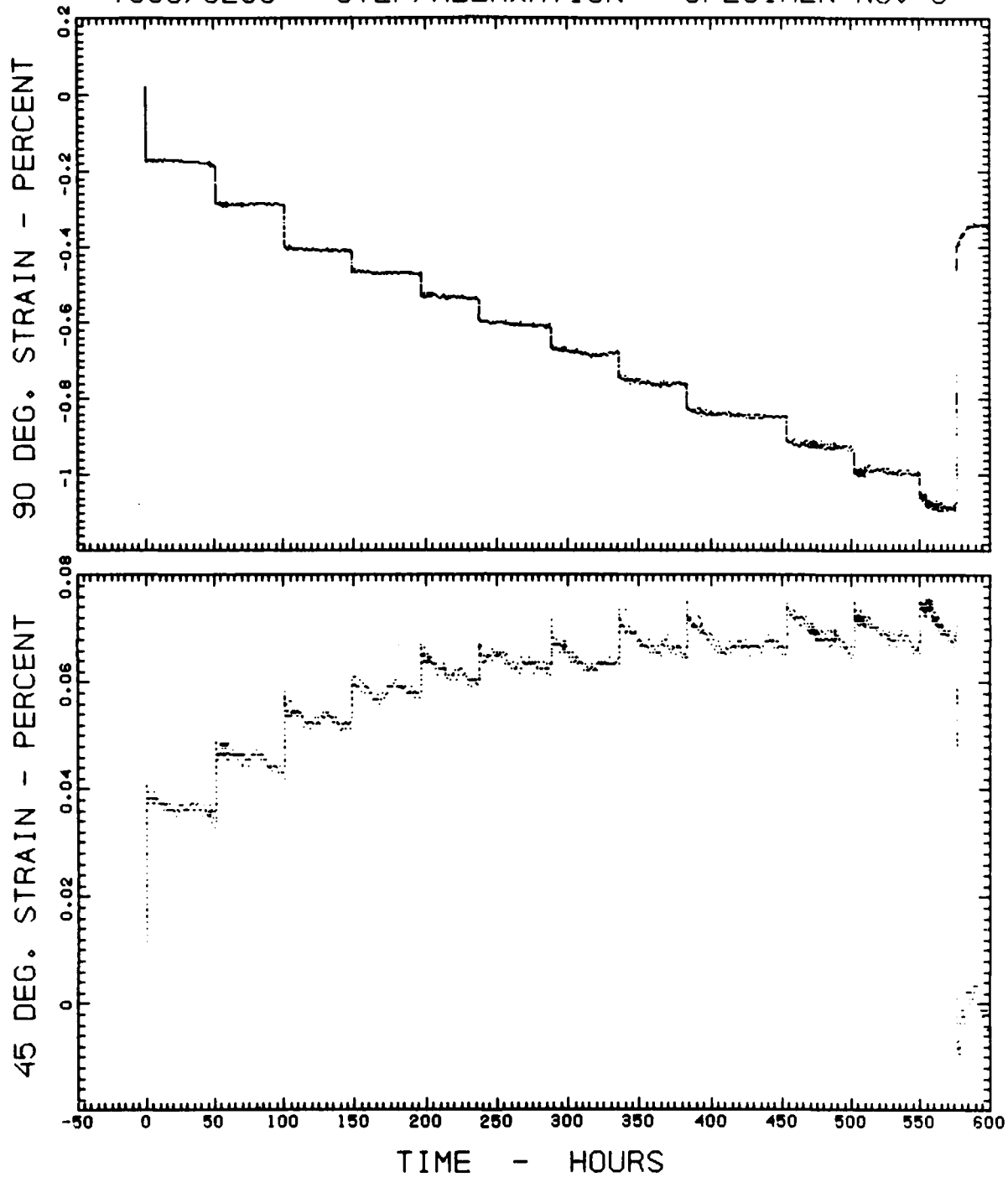

T300/5208 - STEP/RELAXATION - SPECIMEN No. 8 - STEP No. 1

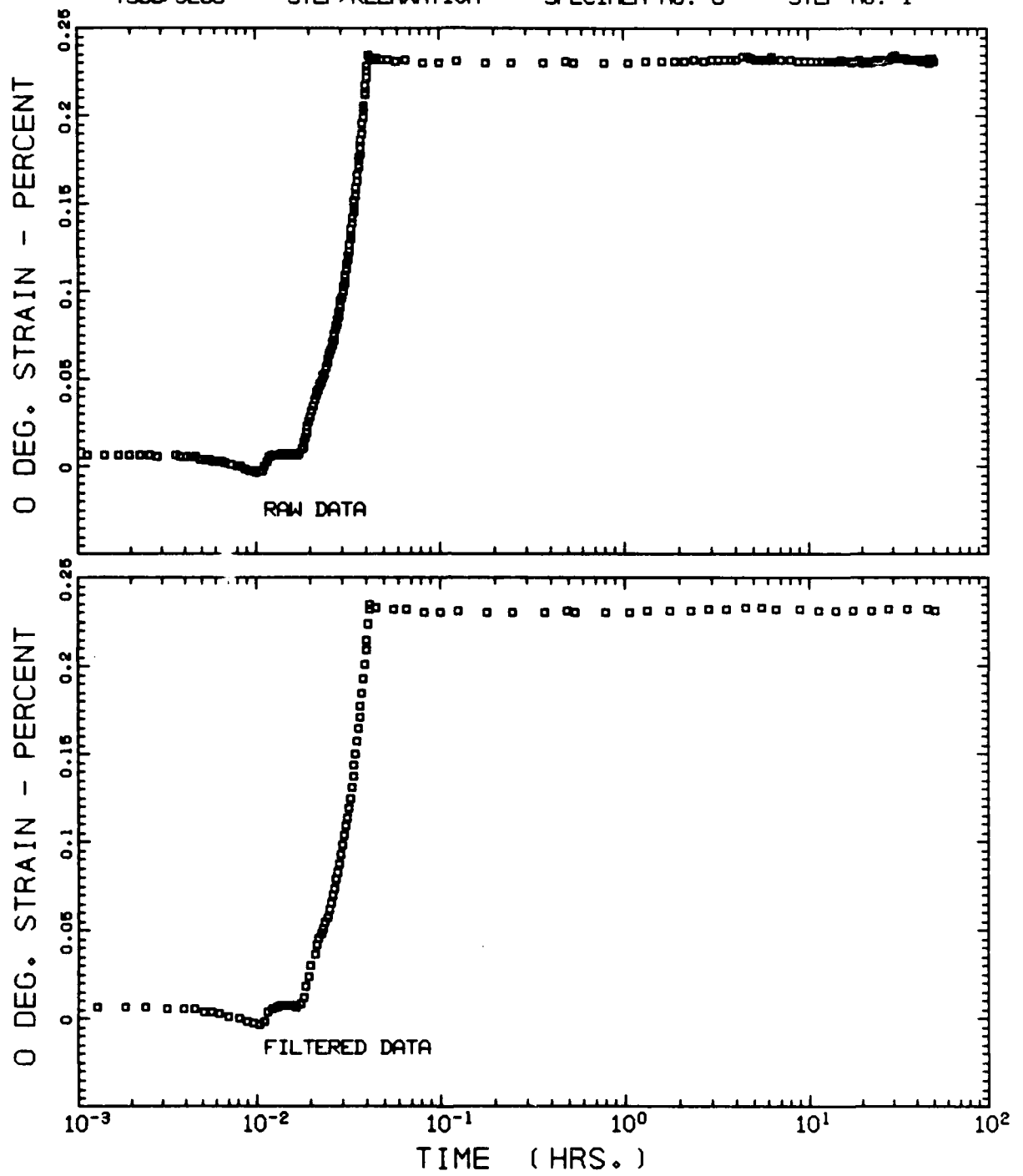

T300/5208 - STEP/RELAXATION - SPECIMEN No. 8 - STEP No. 1

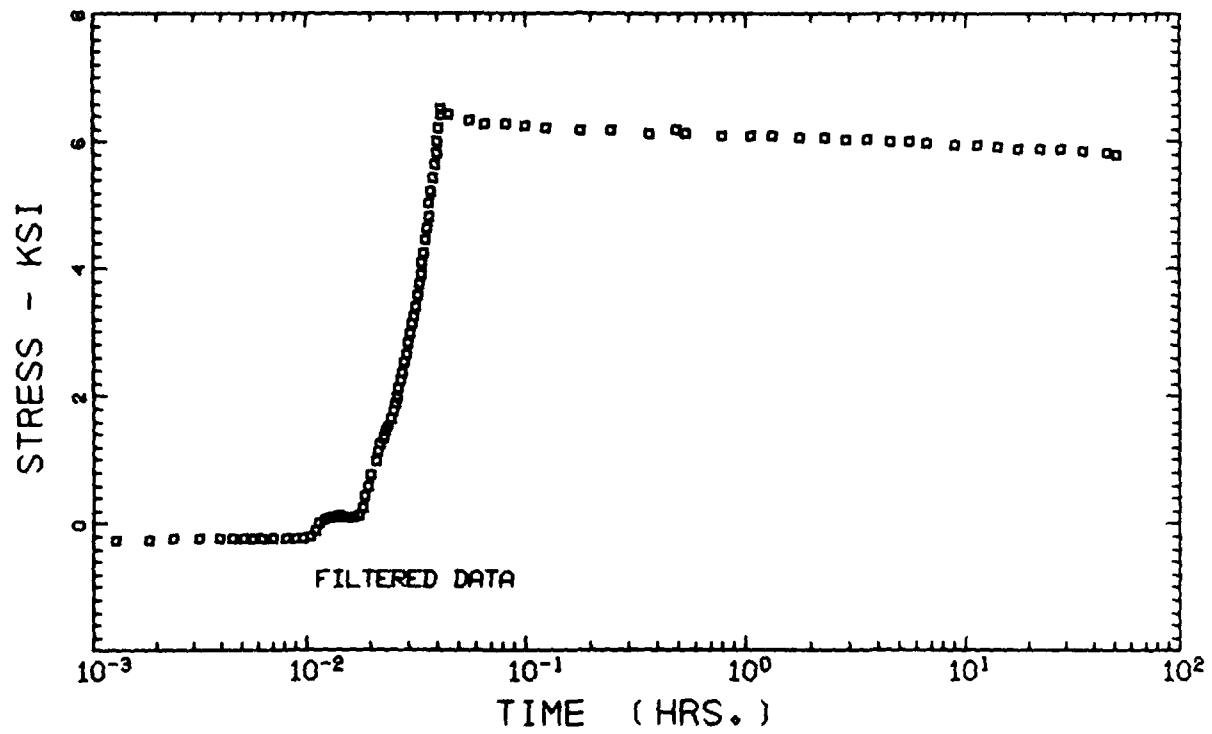
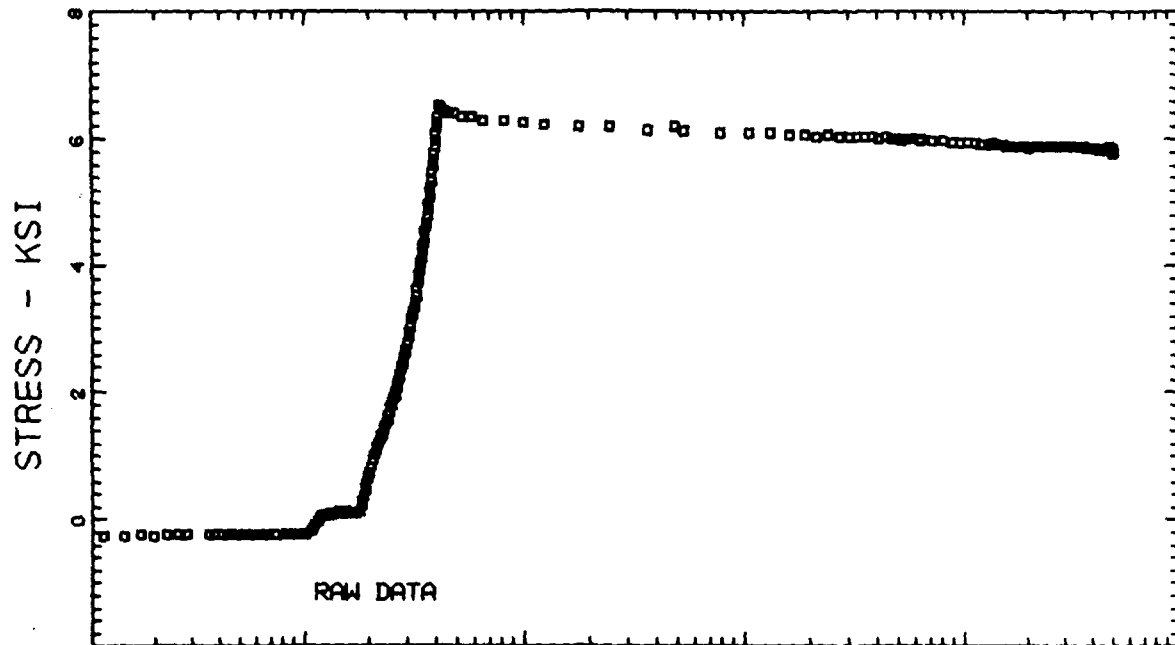

T300/5208 - STEP/RELAXATION - SPECIMEN No. 8 - STEP No. 1

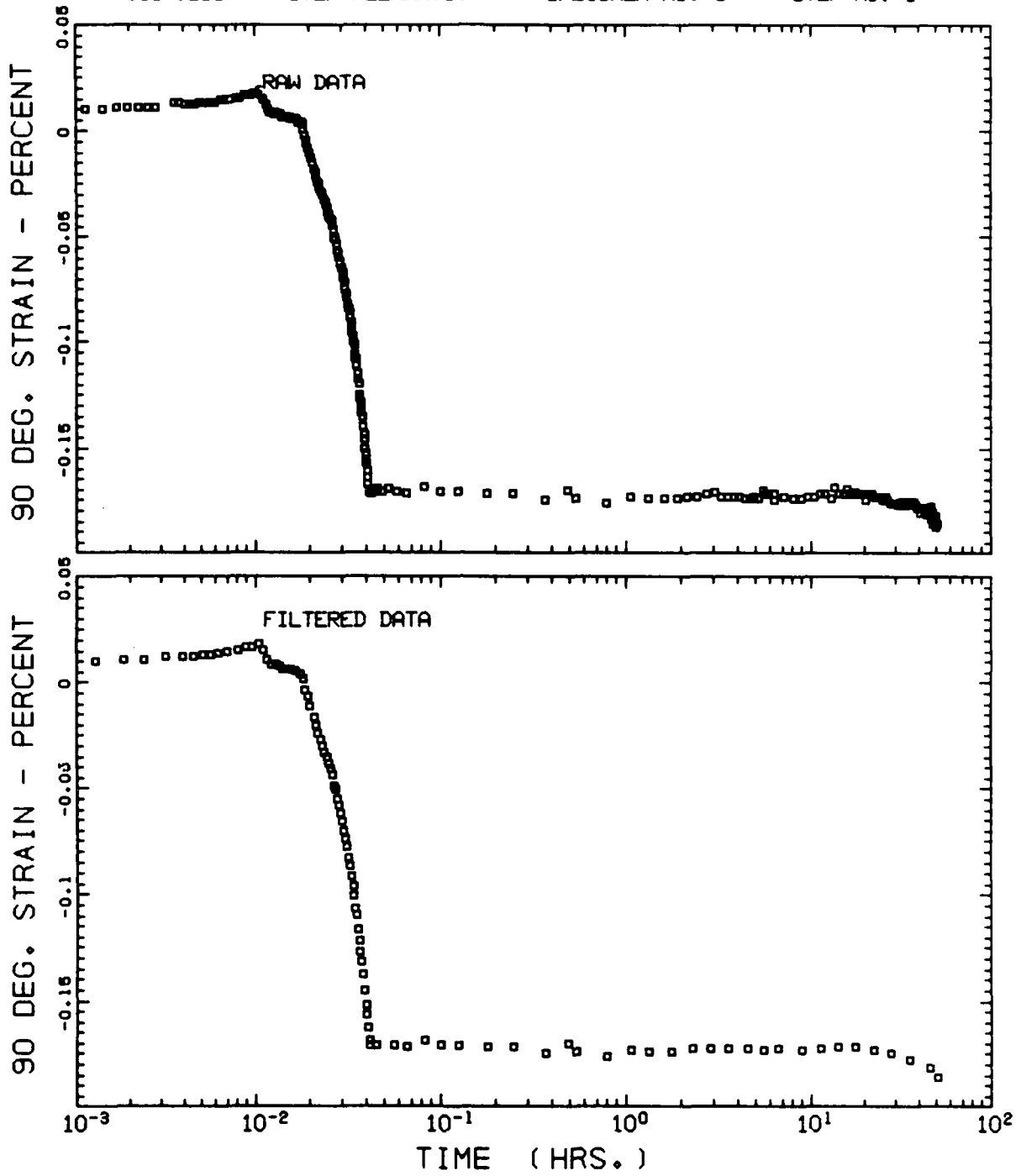

T300/5208 - STEP/RELAXATION - SPECIMEN No. 8 - STEP No. 1

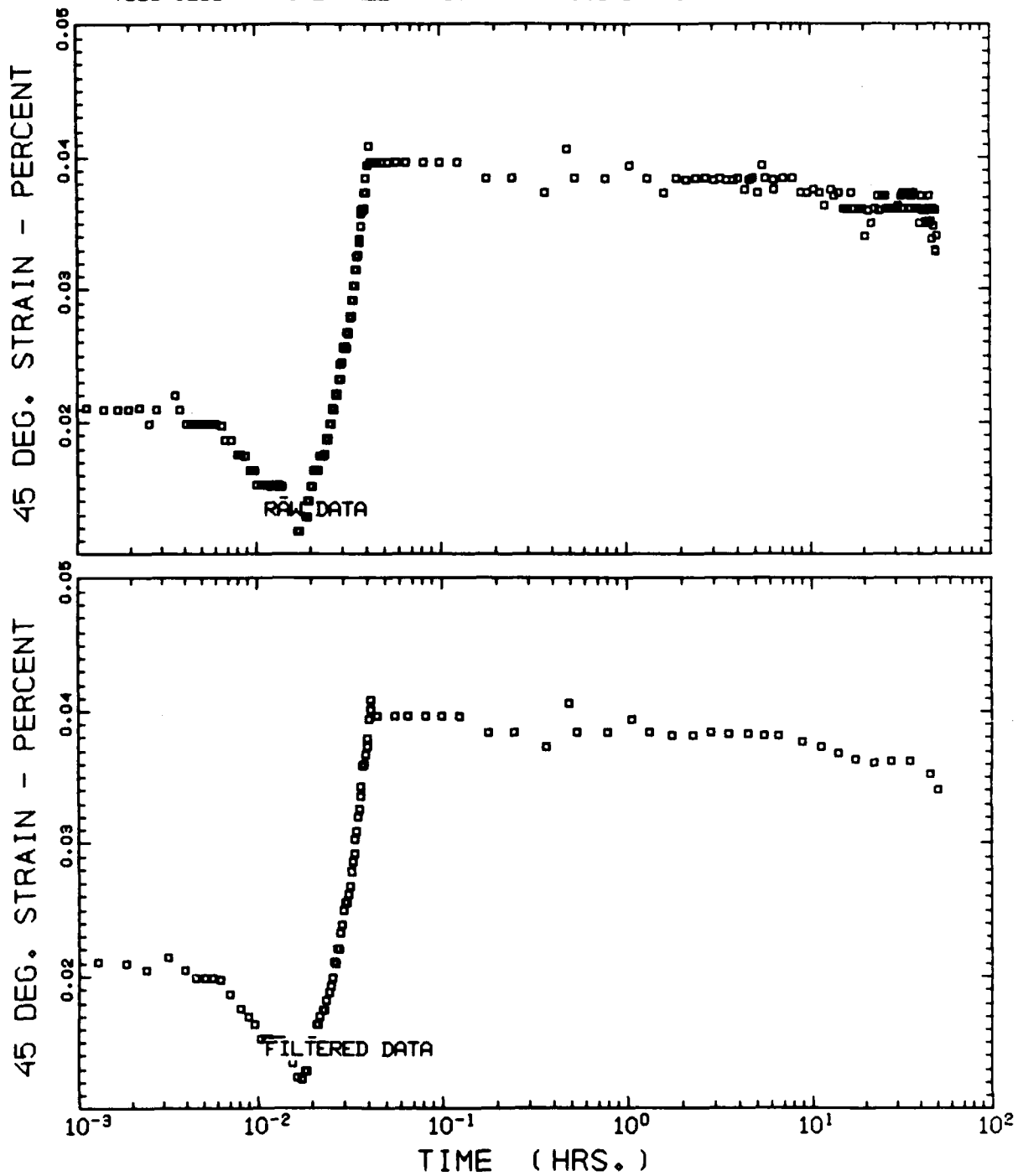

T300/5208 - STEP/RELAXATION - SPECIMEN No. 8 - STEP No. 2

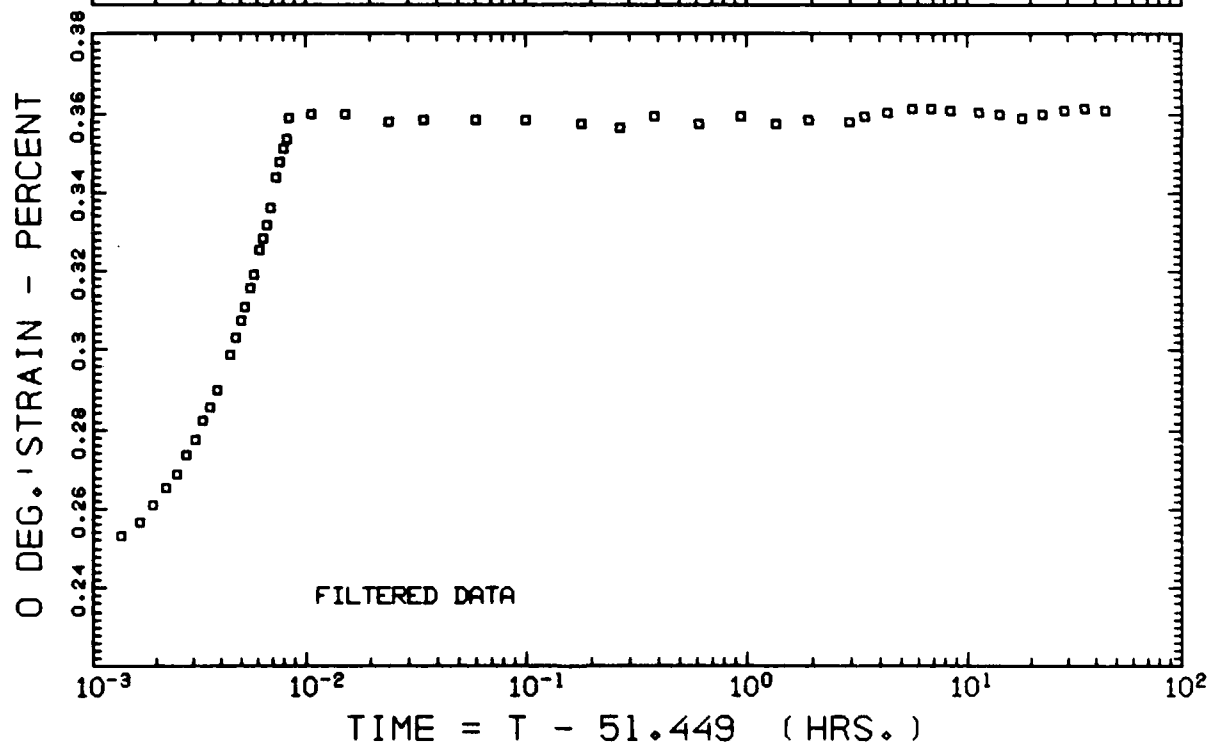
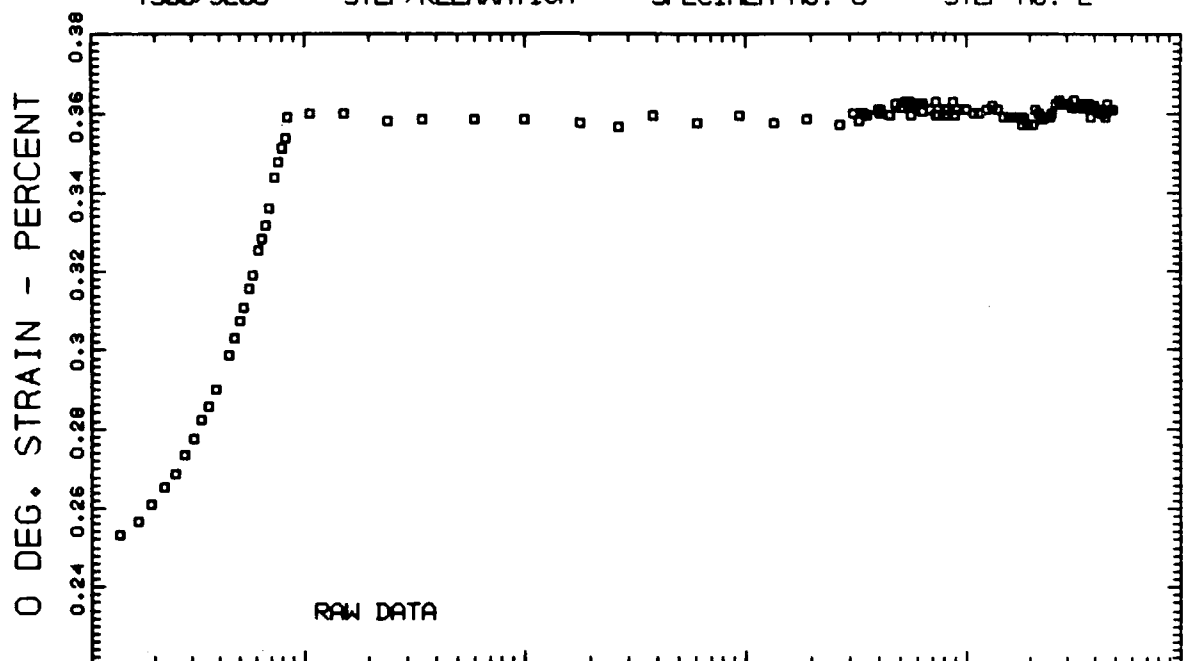



T300/5208 - STEP/RELAXATION - SPECIMEN No. 8 - STEP No. 2

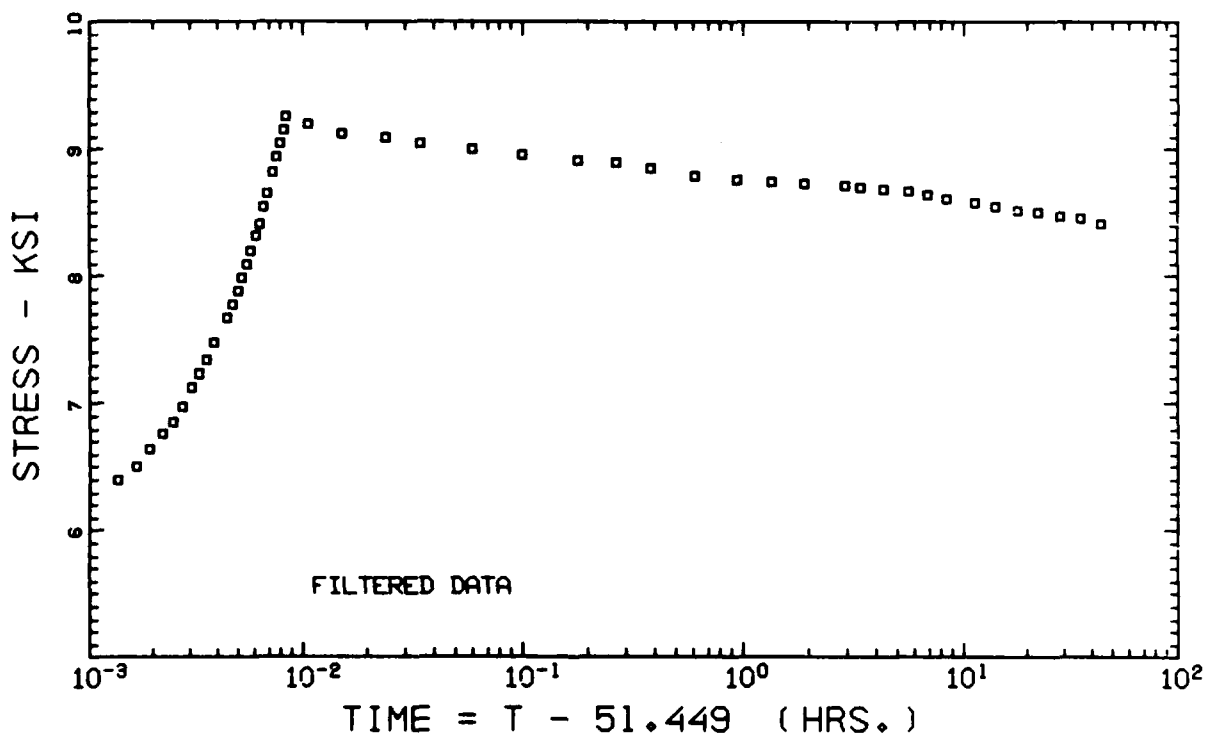
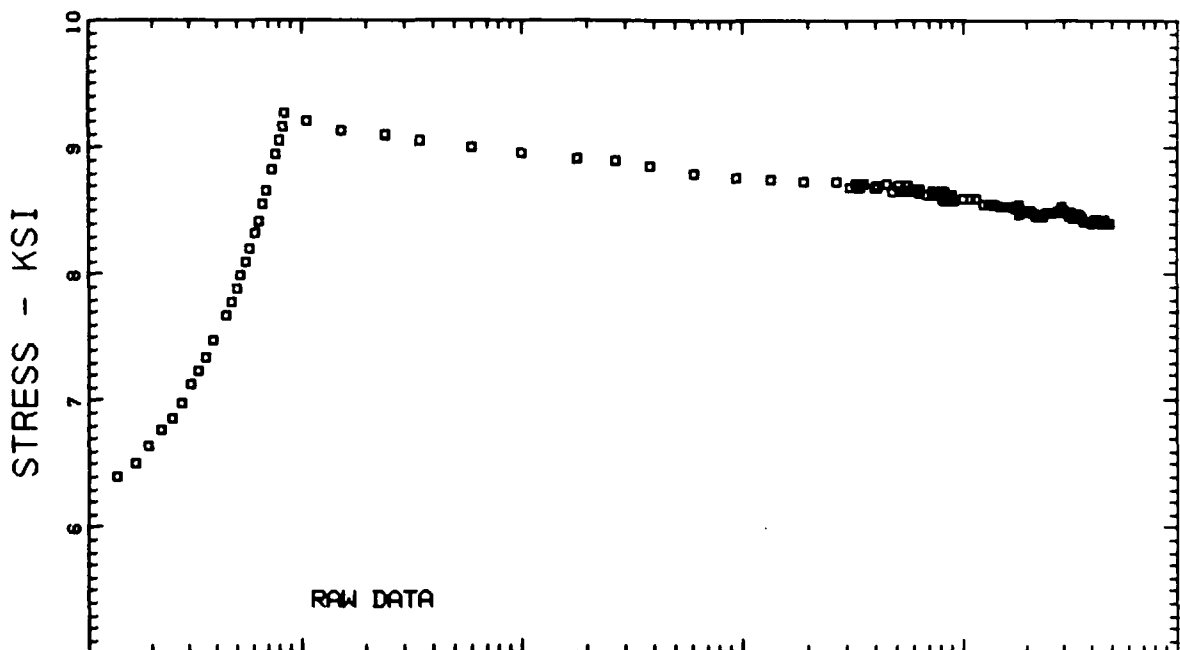

T300/5208 - STEP/RELAXATION - SPECIMEN No. 8 - STEP No. 2

90 DEG. STRAIN - PERCENT

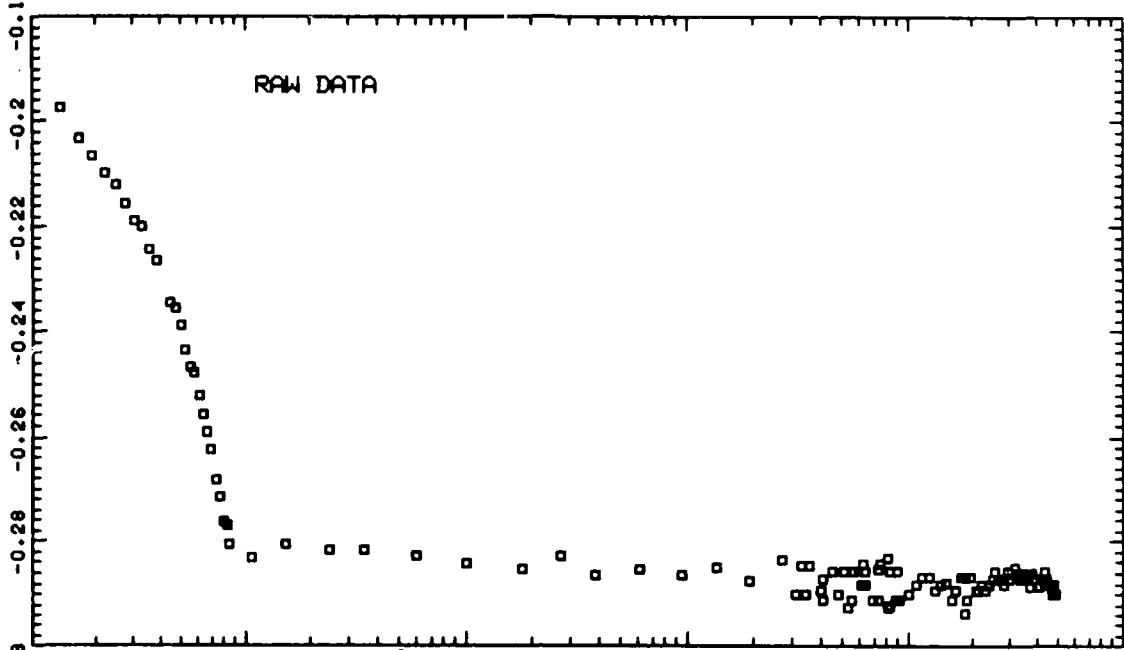

90 DEG. STRAIN - PERCENT

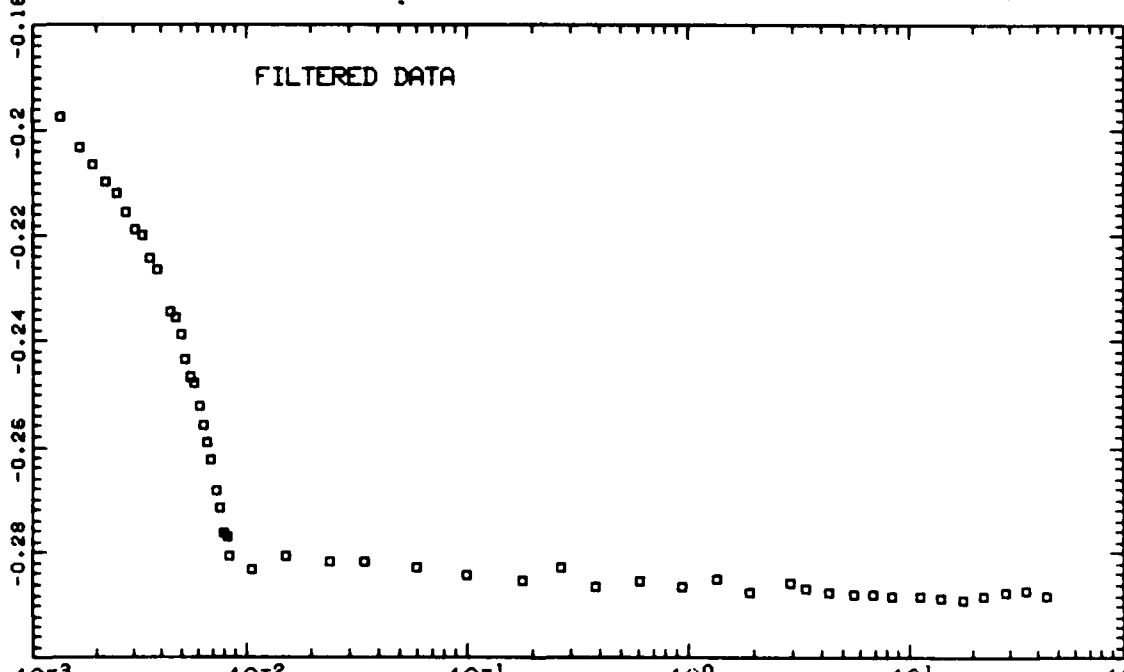

TIME = T - 51.449 (HRS.)

T300/5208 - STEP/RELAXATION - SPECIMEN No. 8 - STEP No. 2

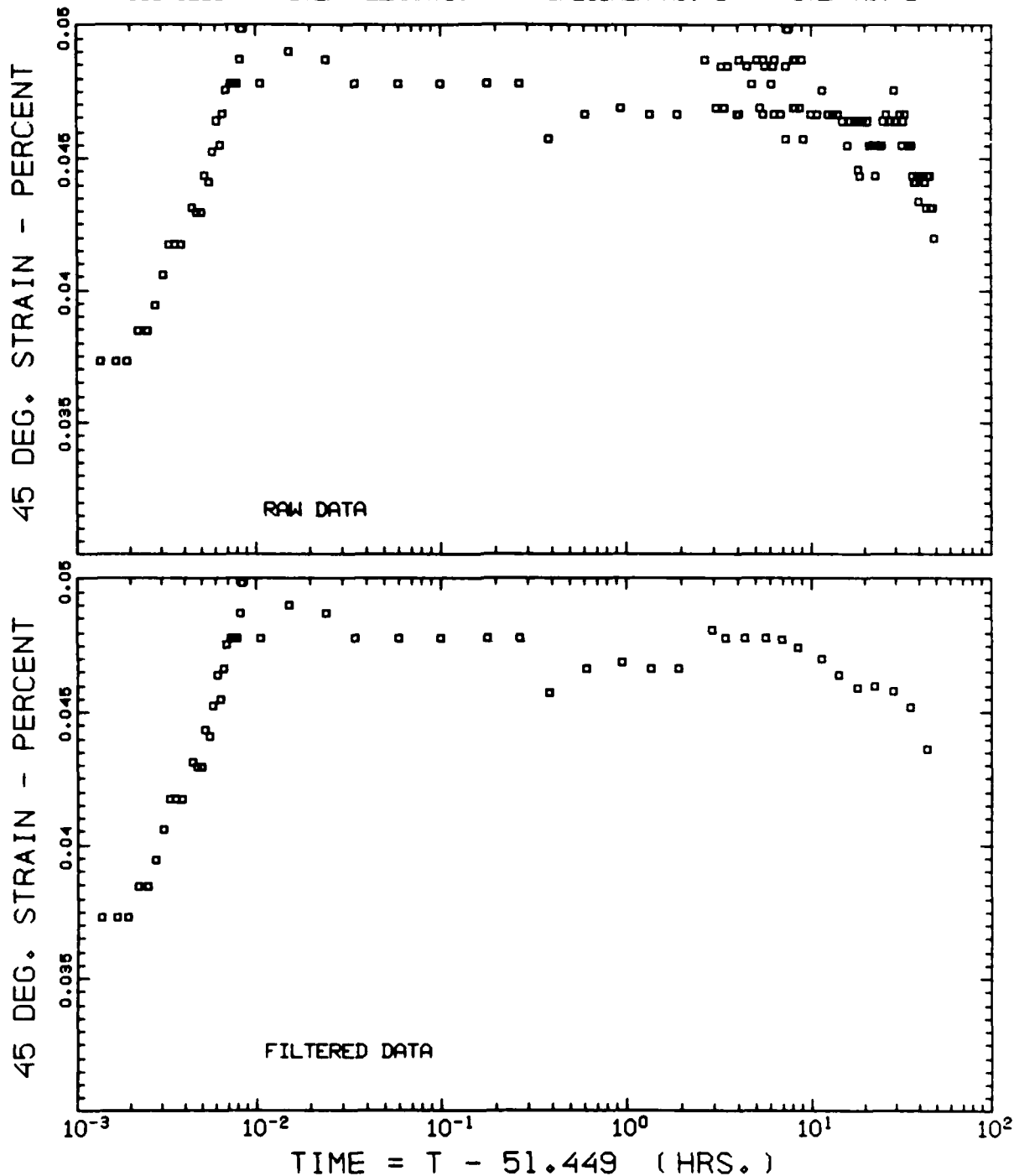

T300/5208 - STEP/RELAXATION - SPECIMEN No. 8 - STEP No. 3

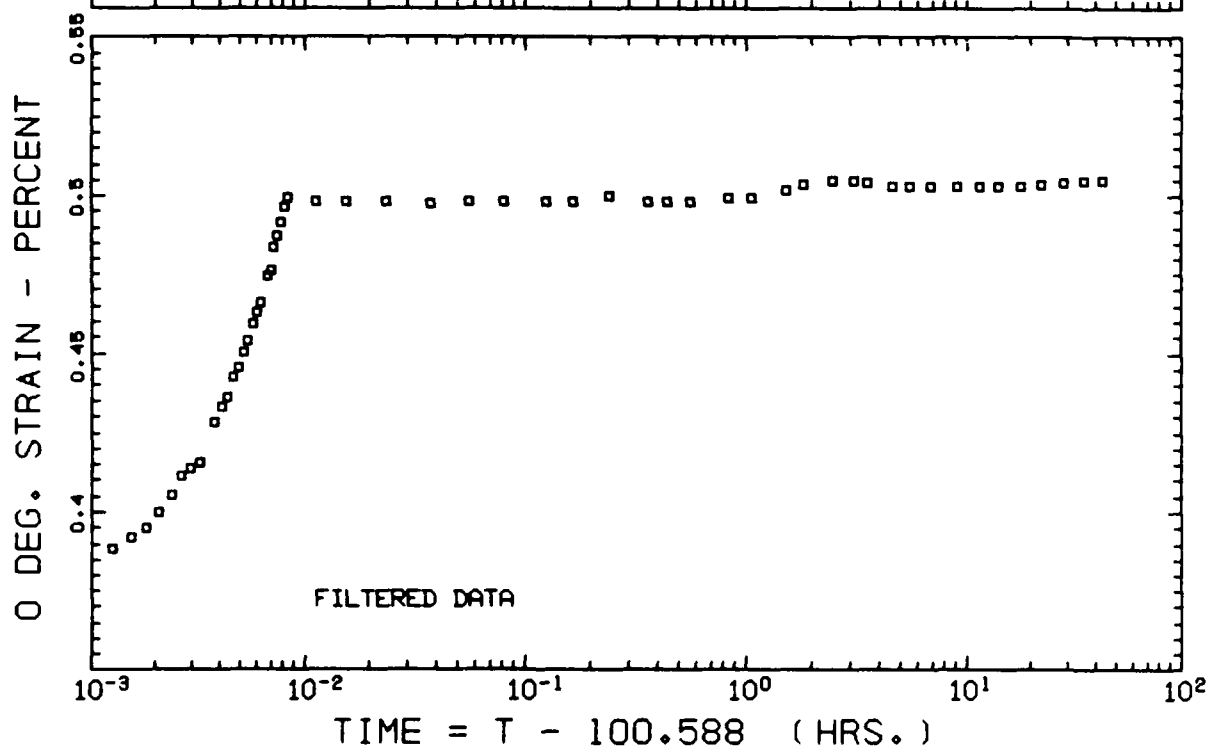
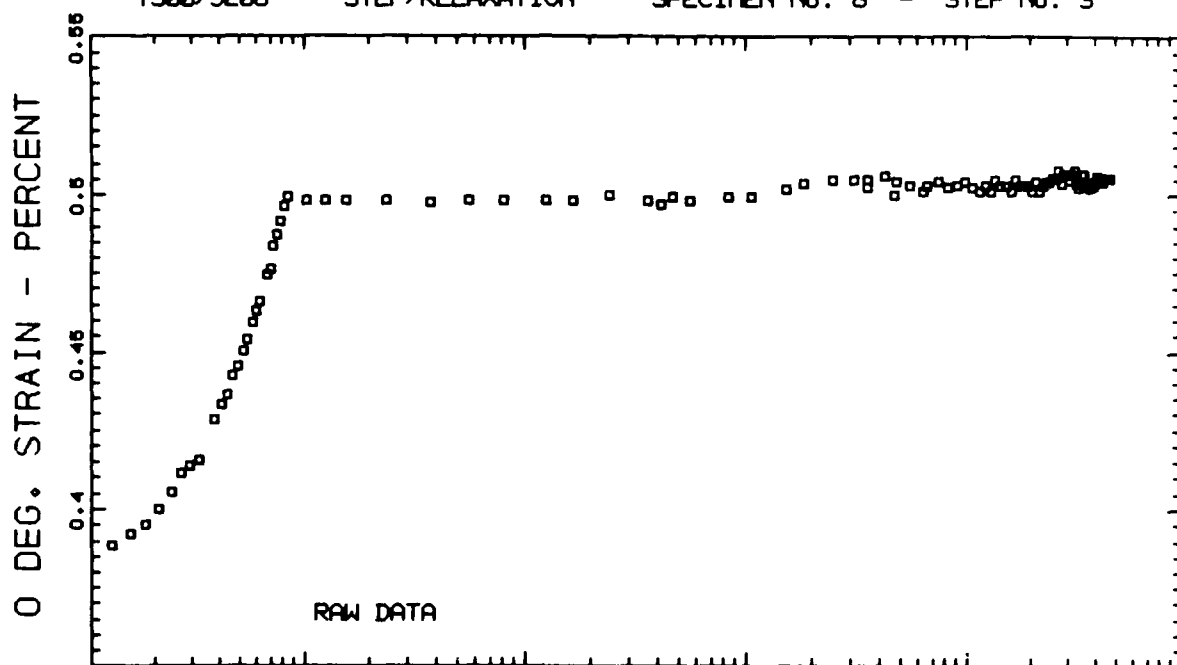

T300/5208 - STEP/RELAXATION - SPECIMEN No. 8 - STEP No. 3

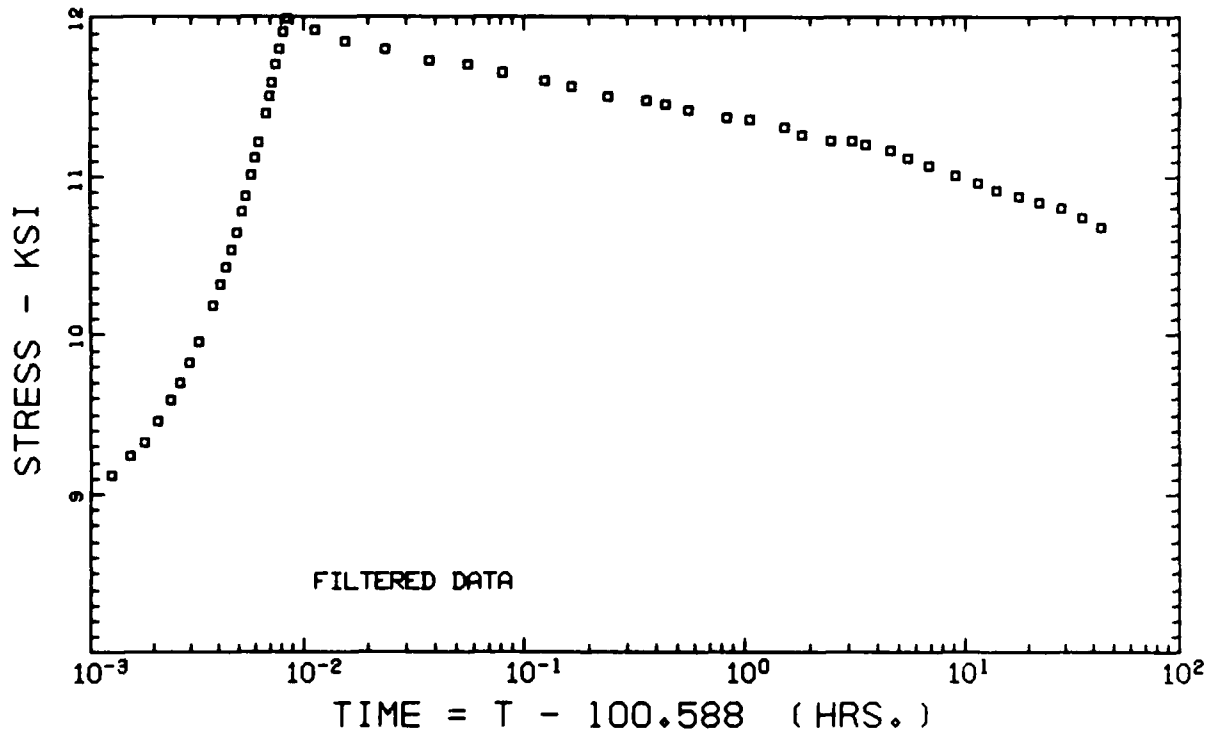
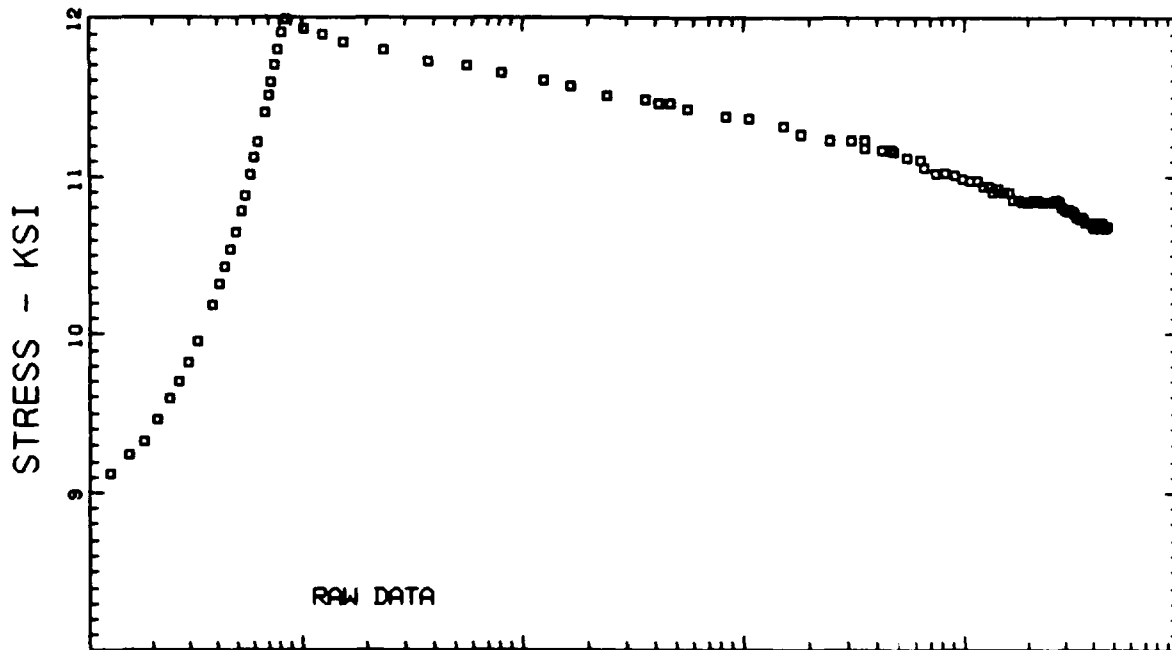

T300/5208 - STEP/RELAXATION - SPECIMEN No. 8 - STEP No. 3

90 DEG. STRAIN - PERCENT

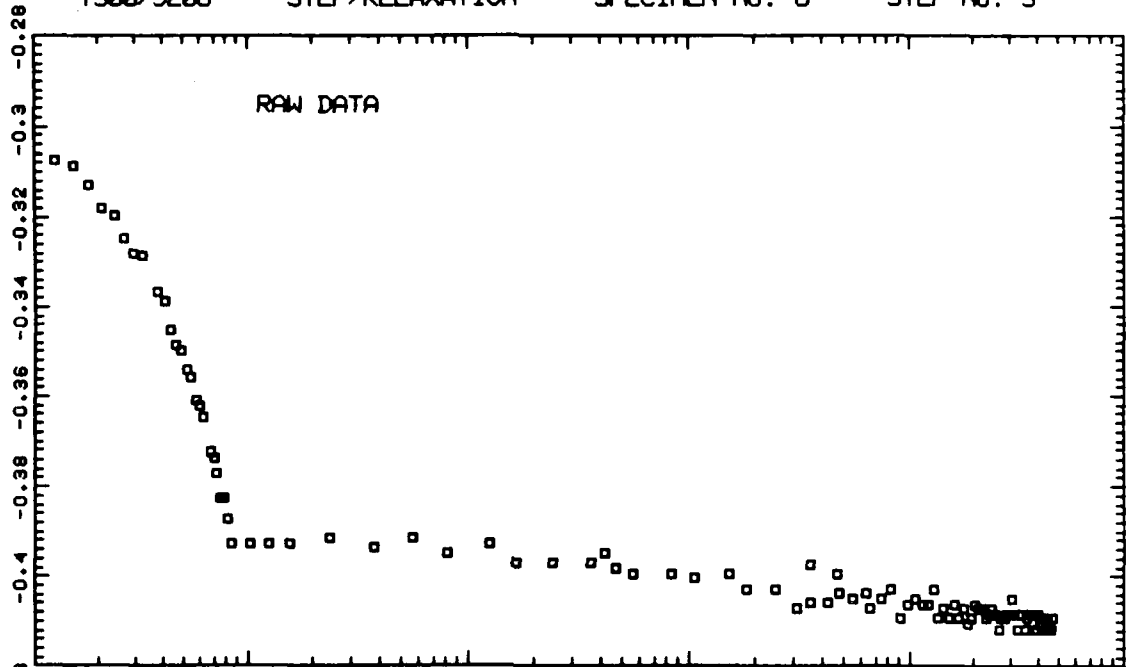

90 DEG. STRAIN - PERCENT

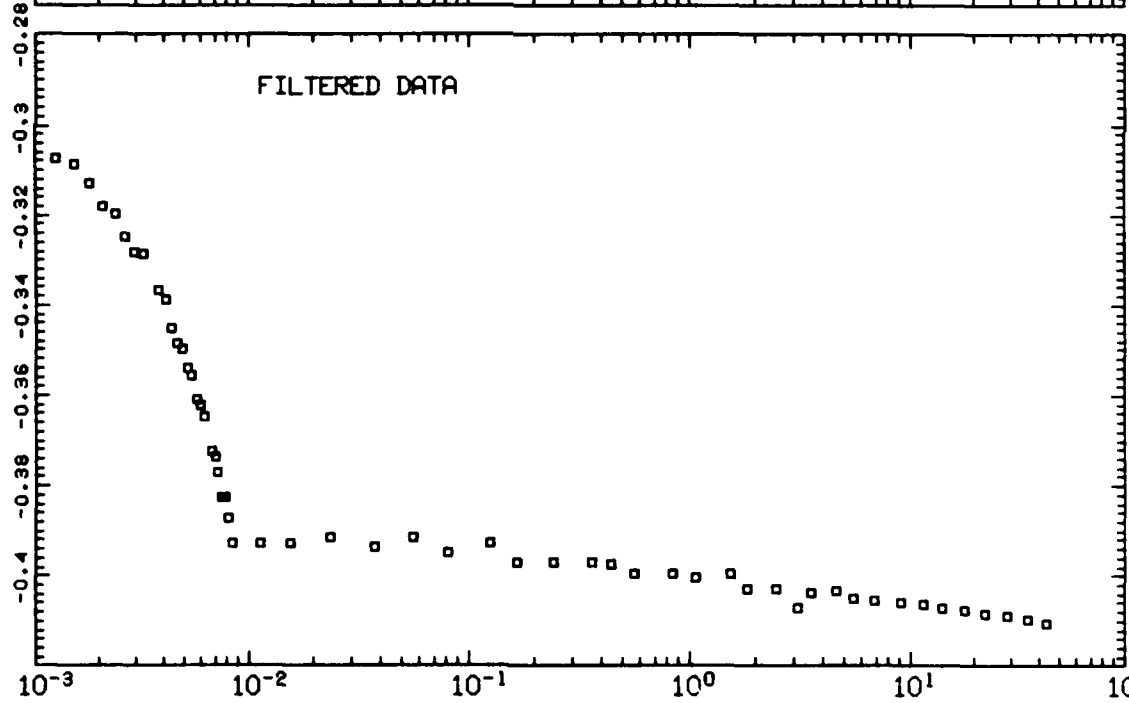

TIME = T - 100.588 (HRS.)

T300/5208 - STEP/RELAXATION - SPECIMEN No. 8 - STEP No. 3

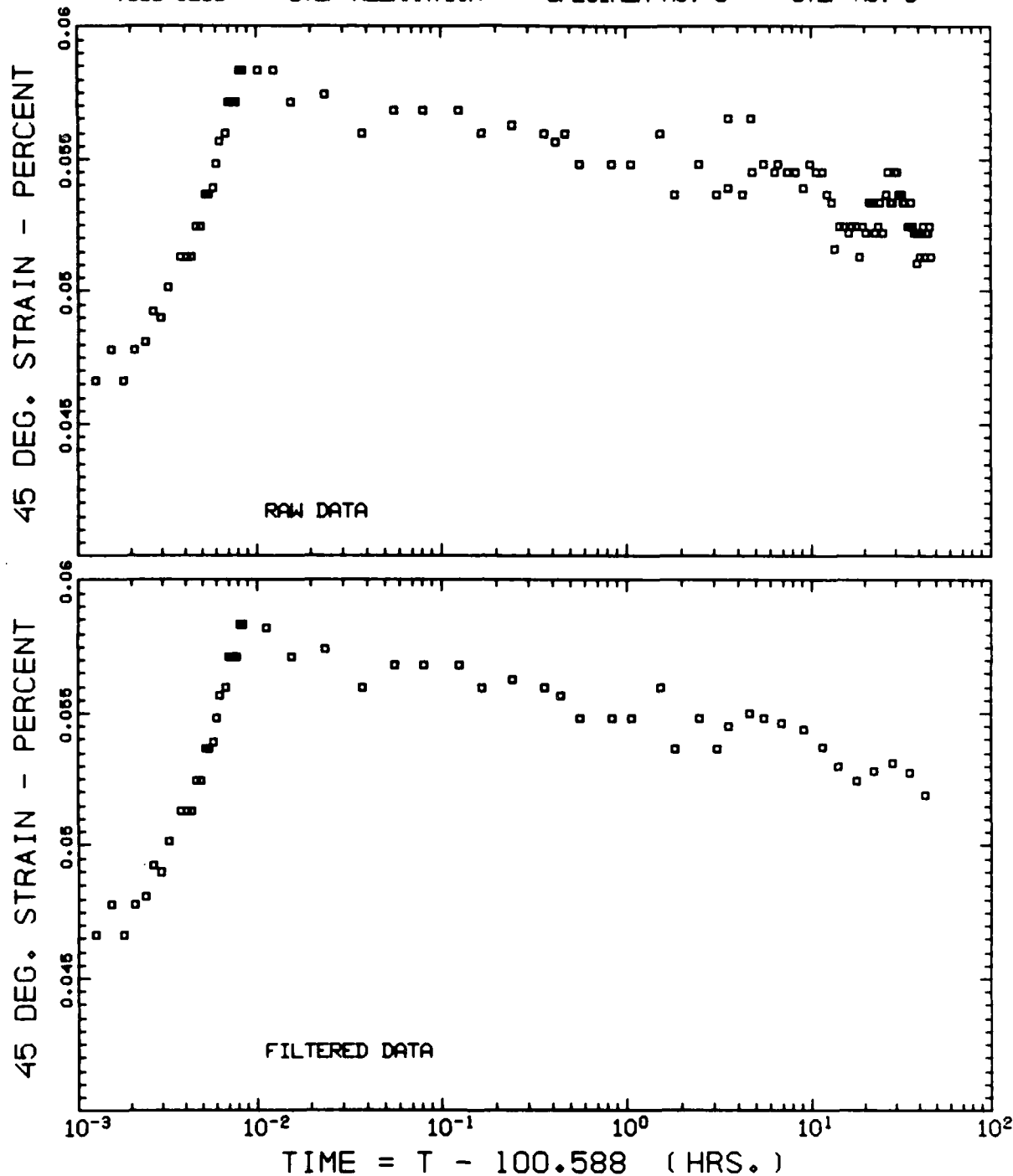

T300/5208 - STEP/RELAXATION - SPECIMEN No. 8 - STEP No. 4

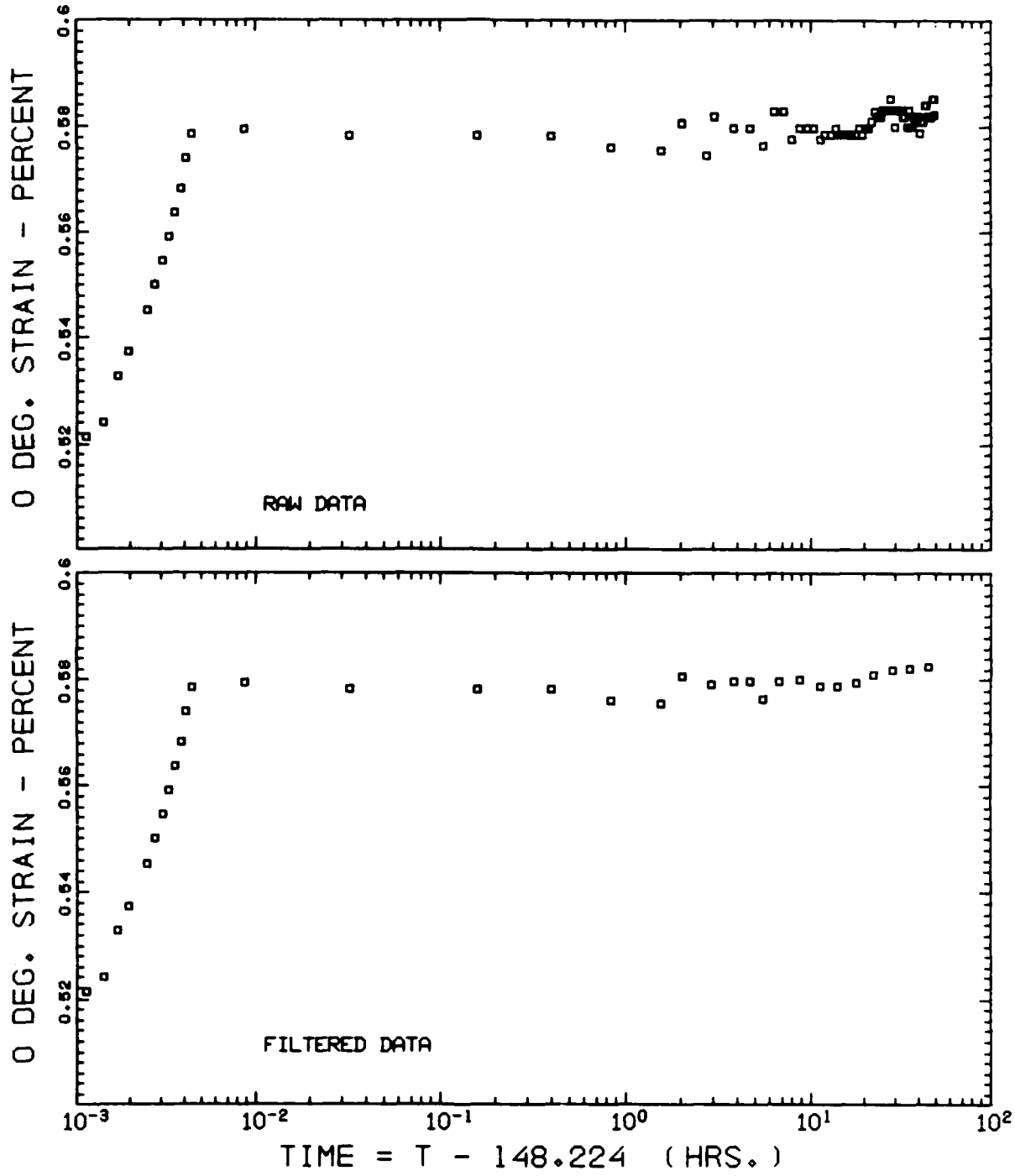



T300/5208 - STEP/RELAXATION - SPECIMEN No. 8 - STEP No. 4

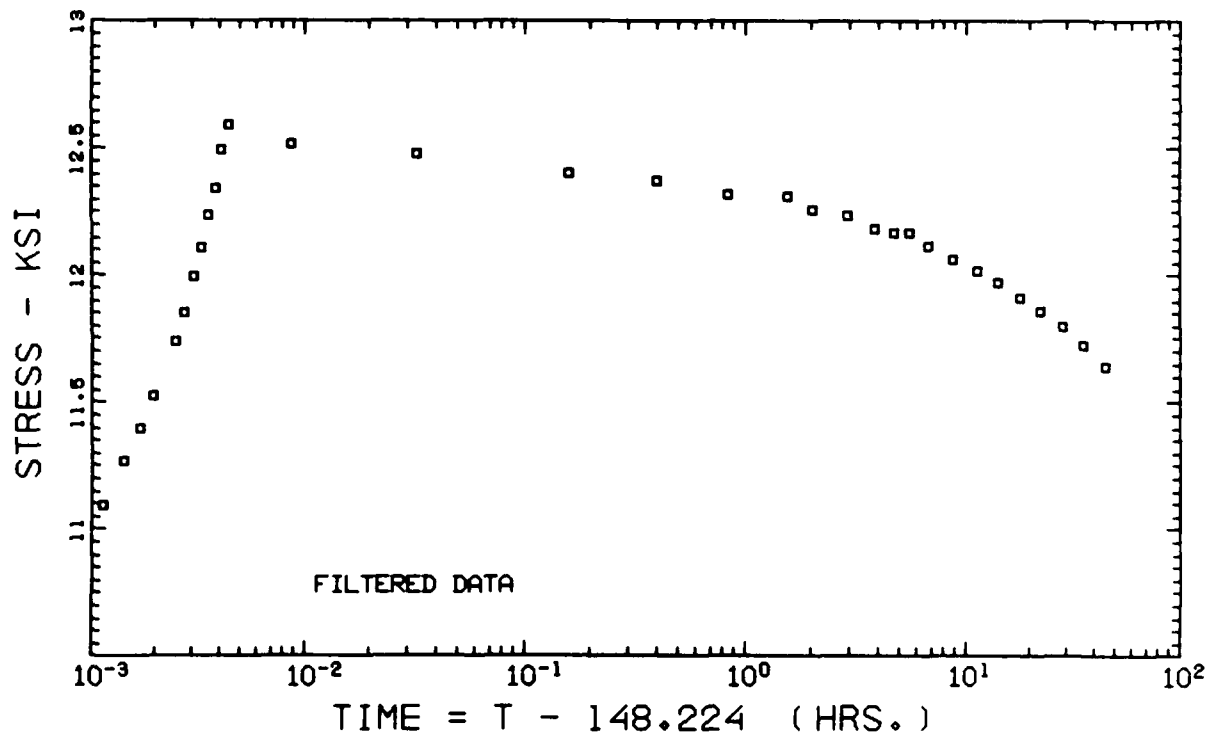
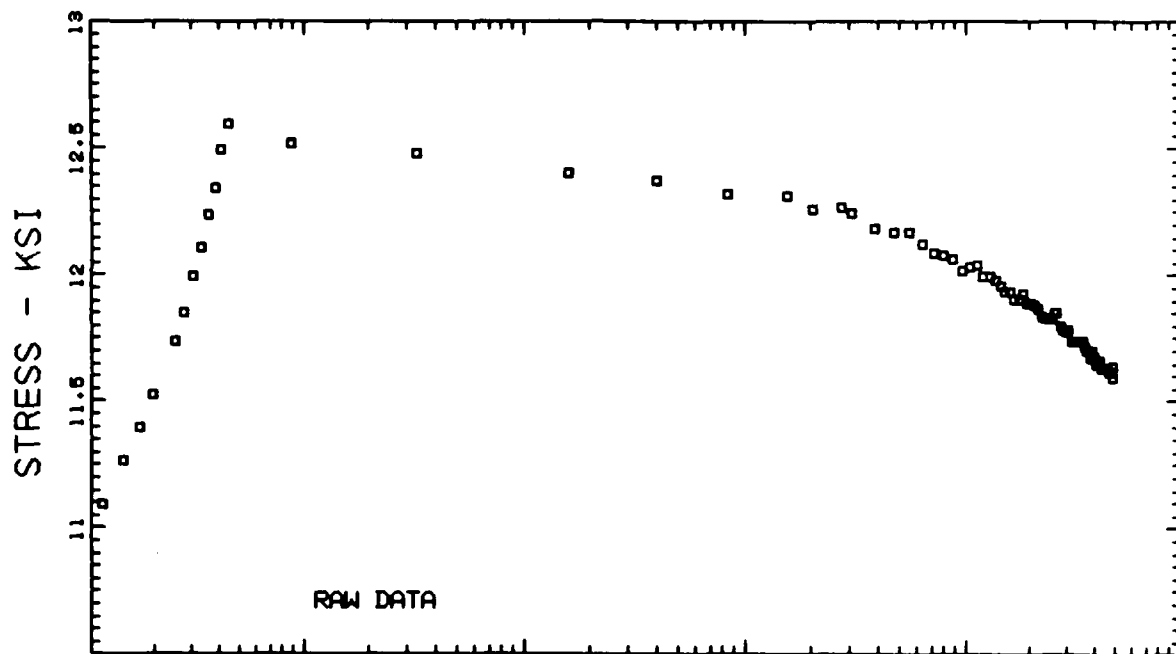

T300/5208 - STEP/RELAXATION - SPECIMEN No. 8 - STEP No. 4

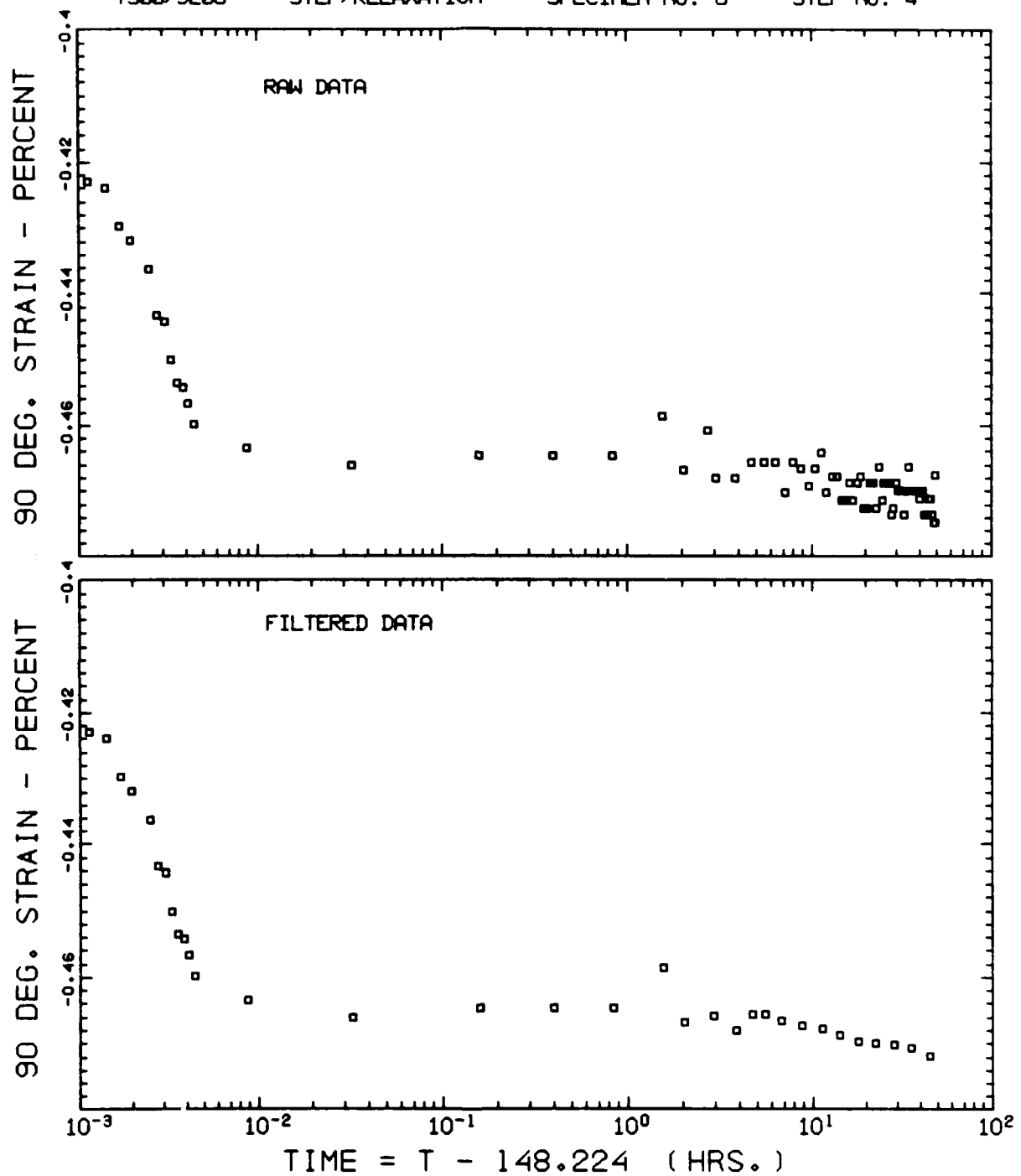

T300/5208 - STEP/RELAXATION - SPECIMEN No. 8 - STEP No. 4

45 DEG. STRAIN - PERCENT

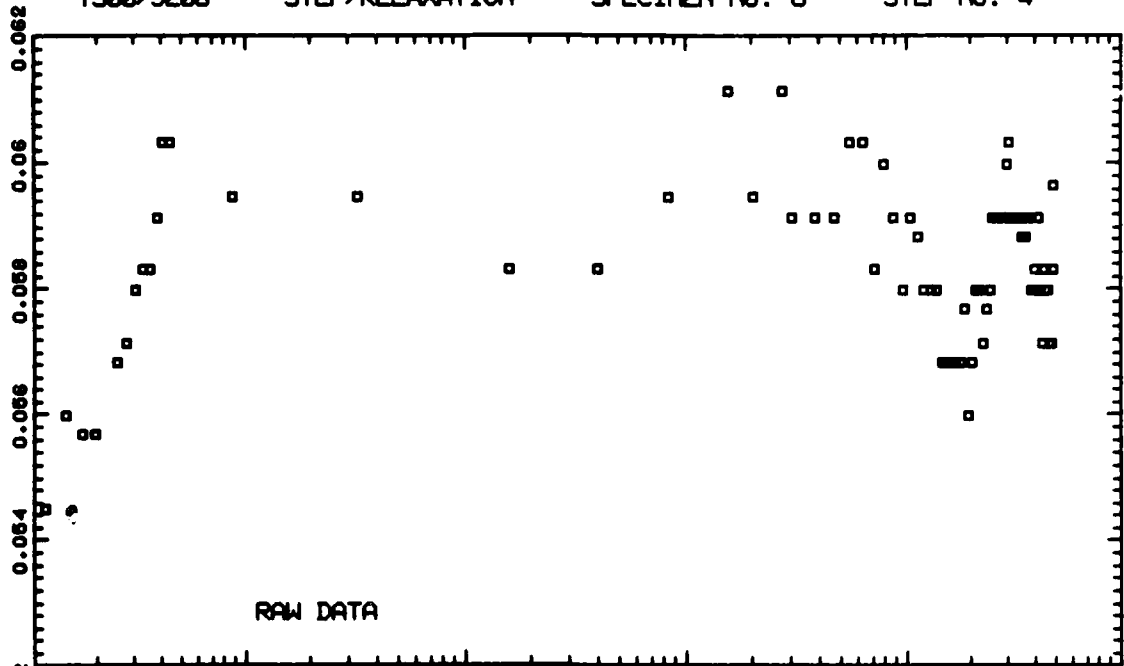

45 DEG. STRAIN - PERCENT

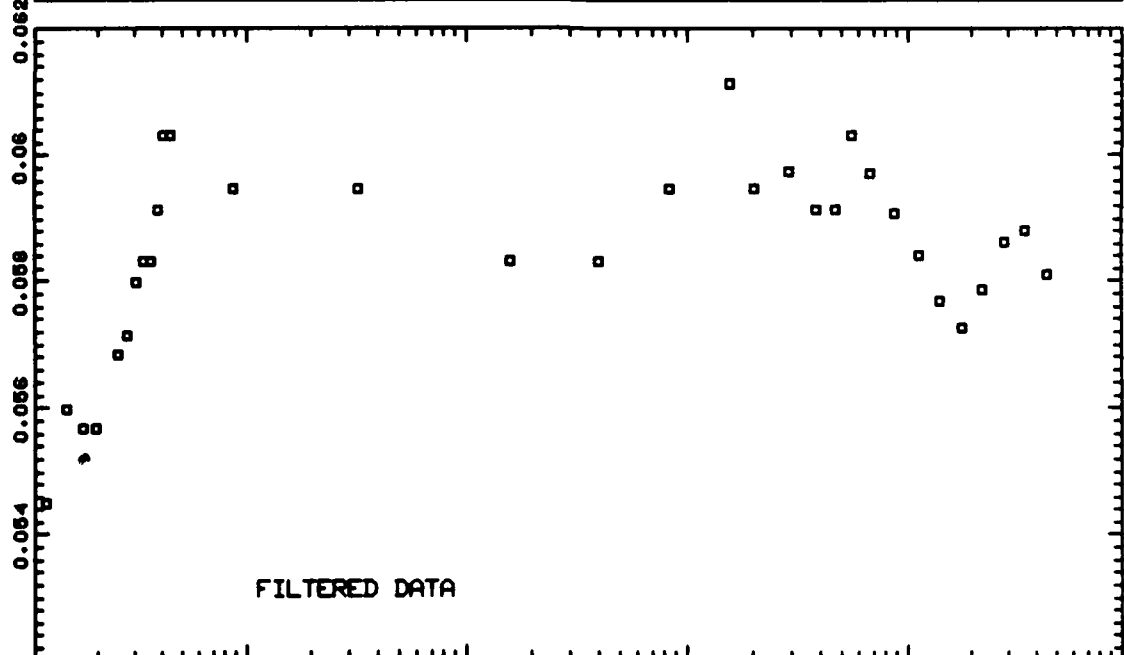

TIME = T - 148.224 (HRS.)

T300/5208 - STEP/RELAXATION - SPECIMEN No. 8 - STEP No. 5

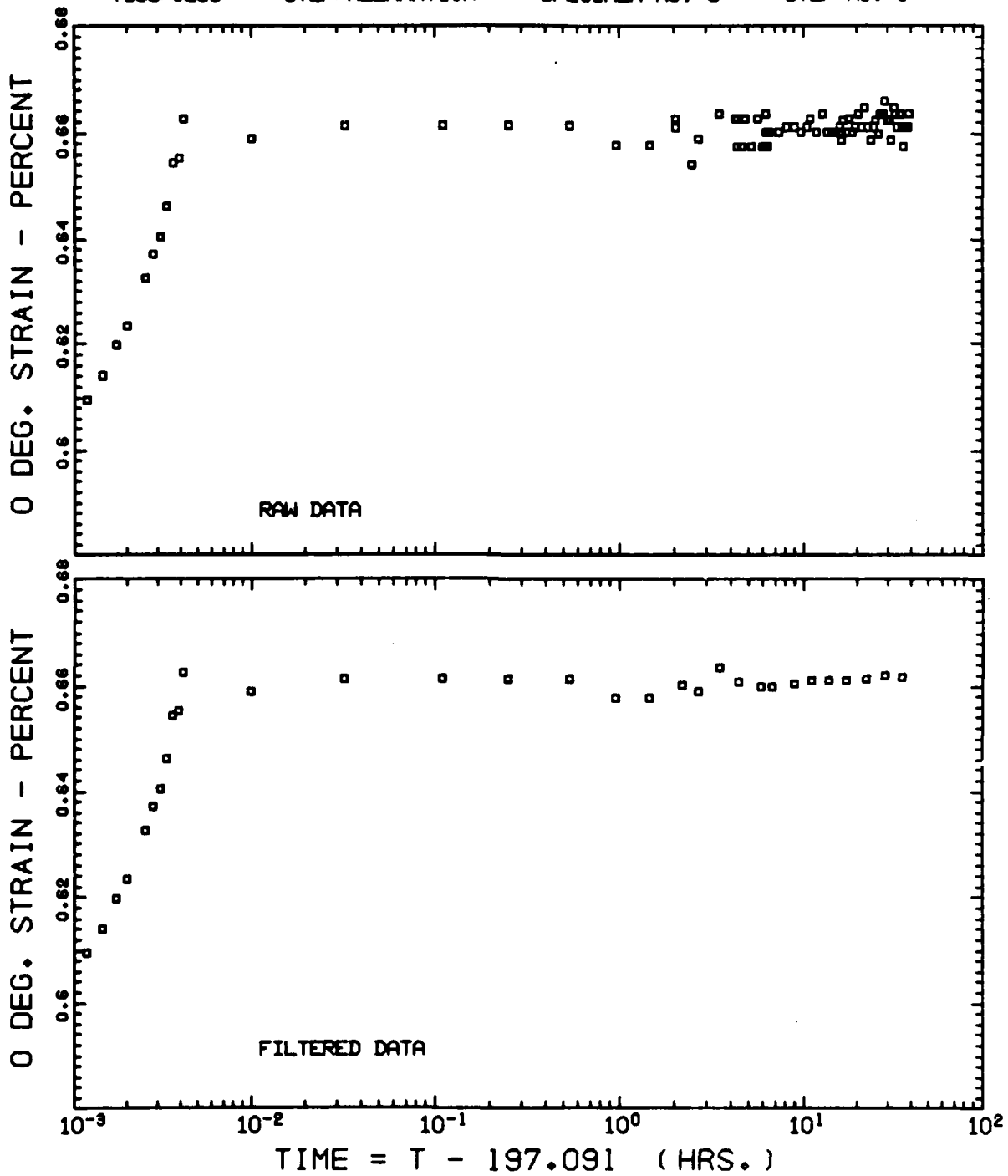

T300/5208 - STEP/RELAXATION - SPECIMEN No. 8 - STEP No. 5

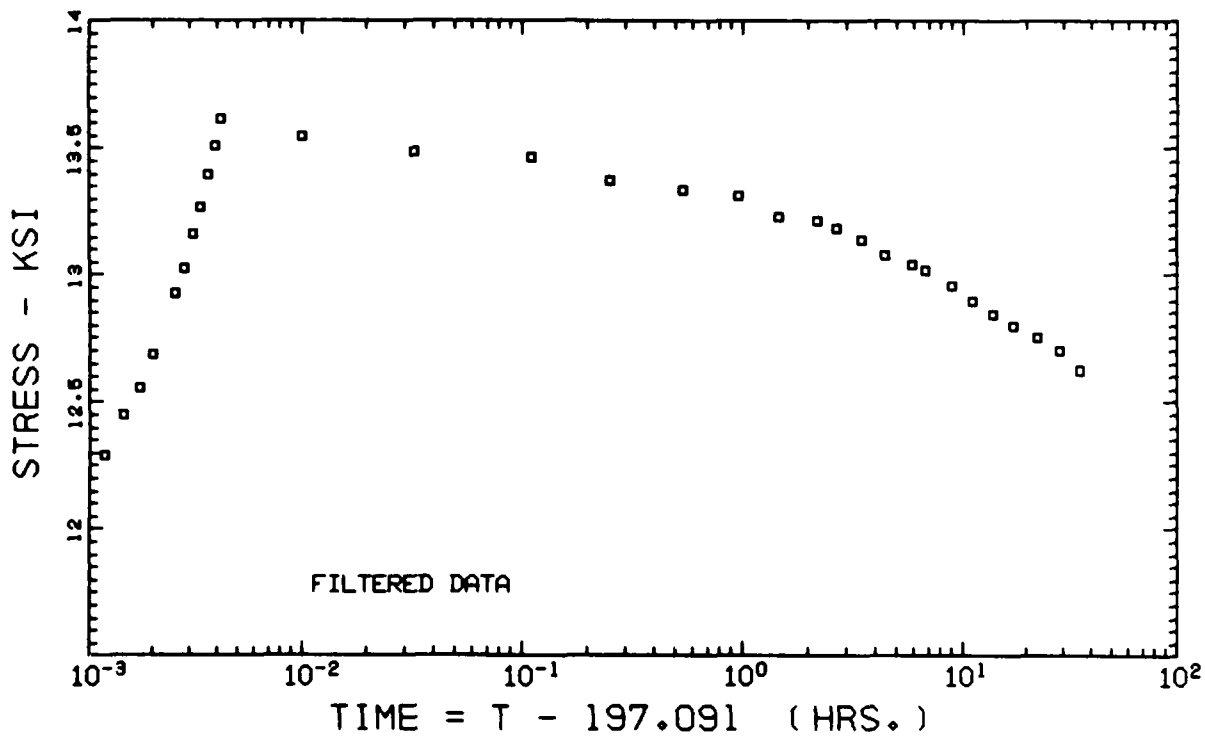
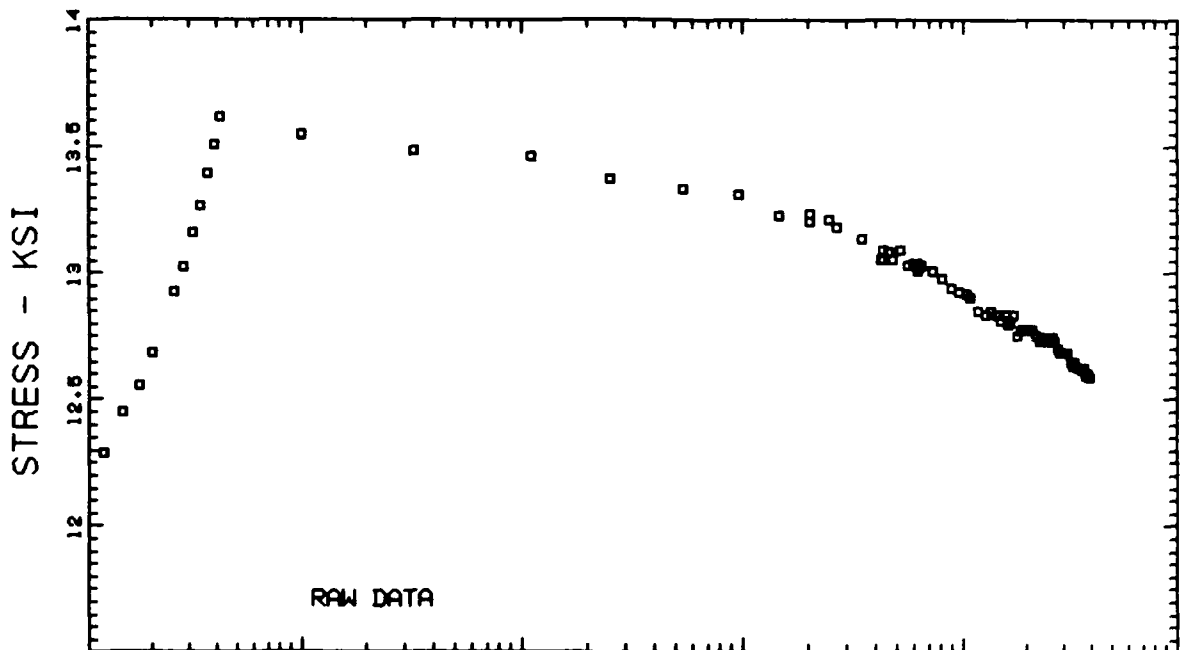

T300/5208 - STEP/RELAXATION - SPECIMEN No. 8 - STEP No. 5

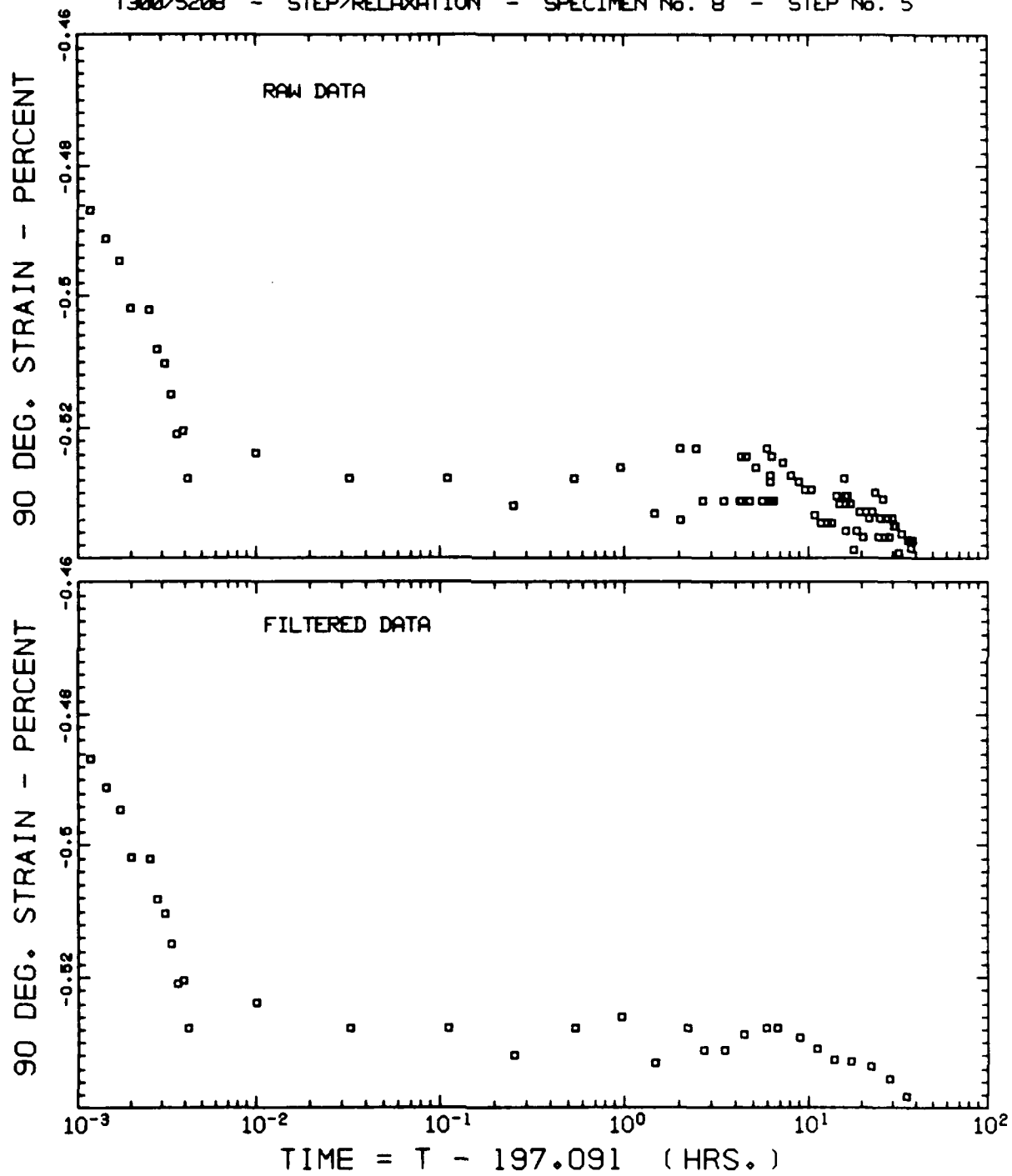

T300/5208 - STEP/RELAXATION - SPECIMEN No. 8 - STEP No. 5

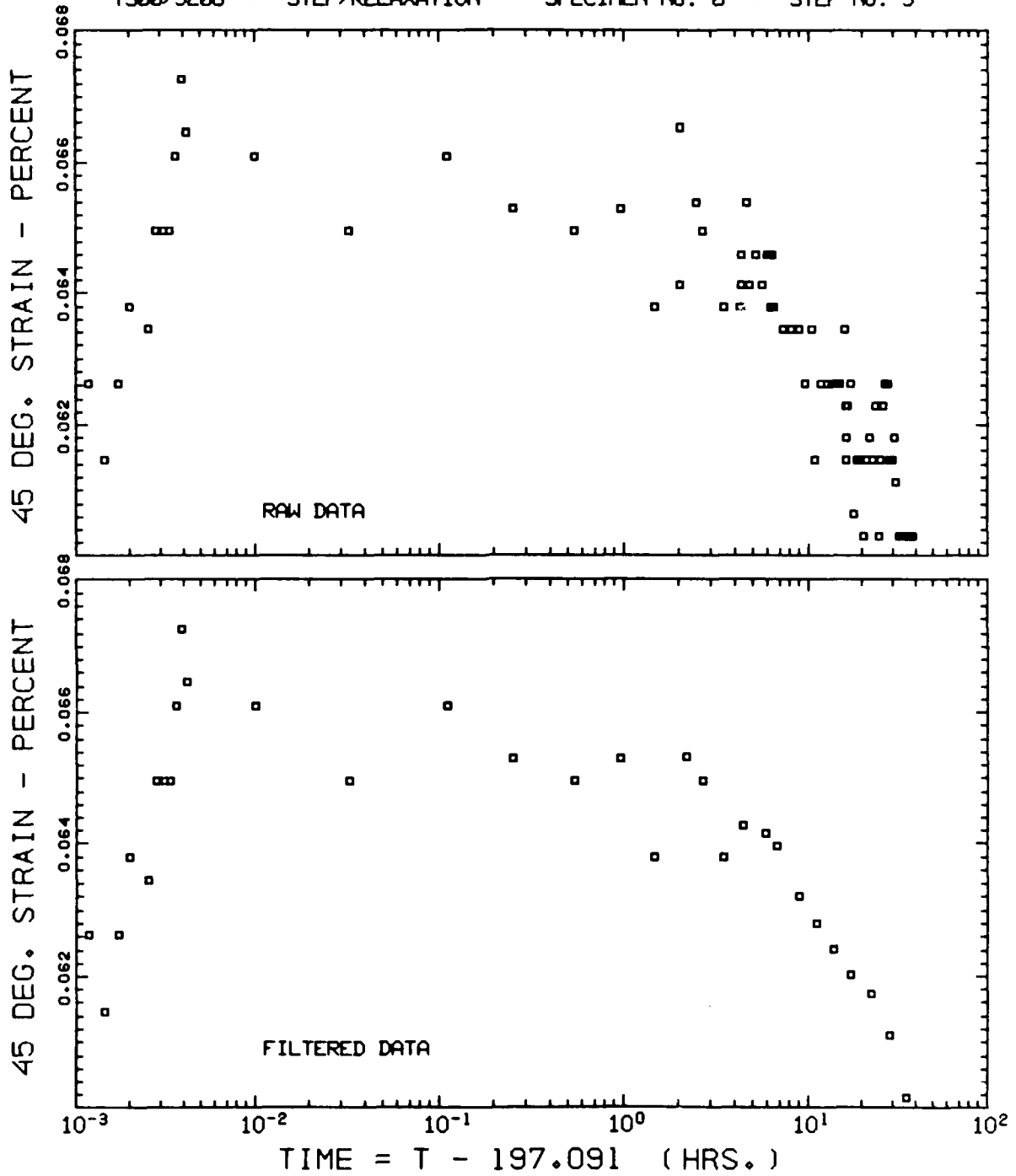

AD-A141 697

MATRIX-DOMINATED TIME-DEPENDENT DEFORMATION AND DAMAGE  
OF GRAPHITE EPOXY. (U) LAWRENCE LIVERMORE NATIONAL LAB  
CA E H WU ET AL. MAY 83 UCID-19765 AFML-TR-83-3056  
W-7485-ENG-48

4/6

UNCLASSIFIED

F/G 11/9

NL

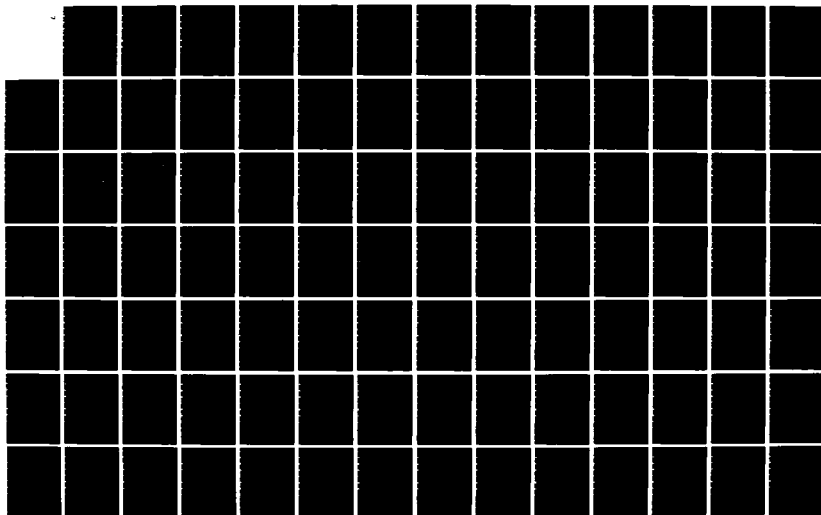



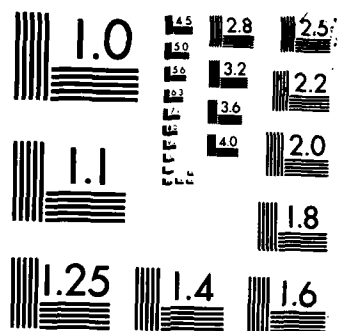

MICROCOPY RESOLUTION TEST CHART  
NATIONAL BUREAU OF STANDARDS 1963 A

T300/5208 - STEP/RELAXATION - SPECIMEN No. 8 - STEP No. 5

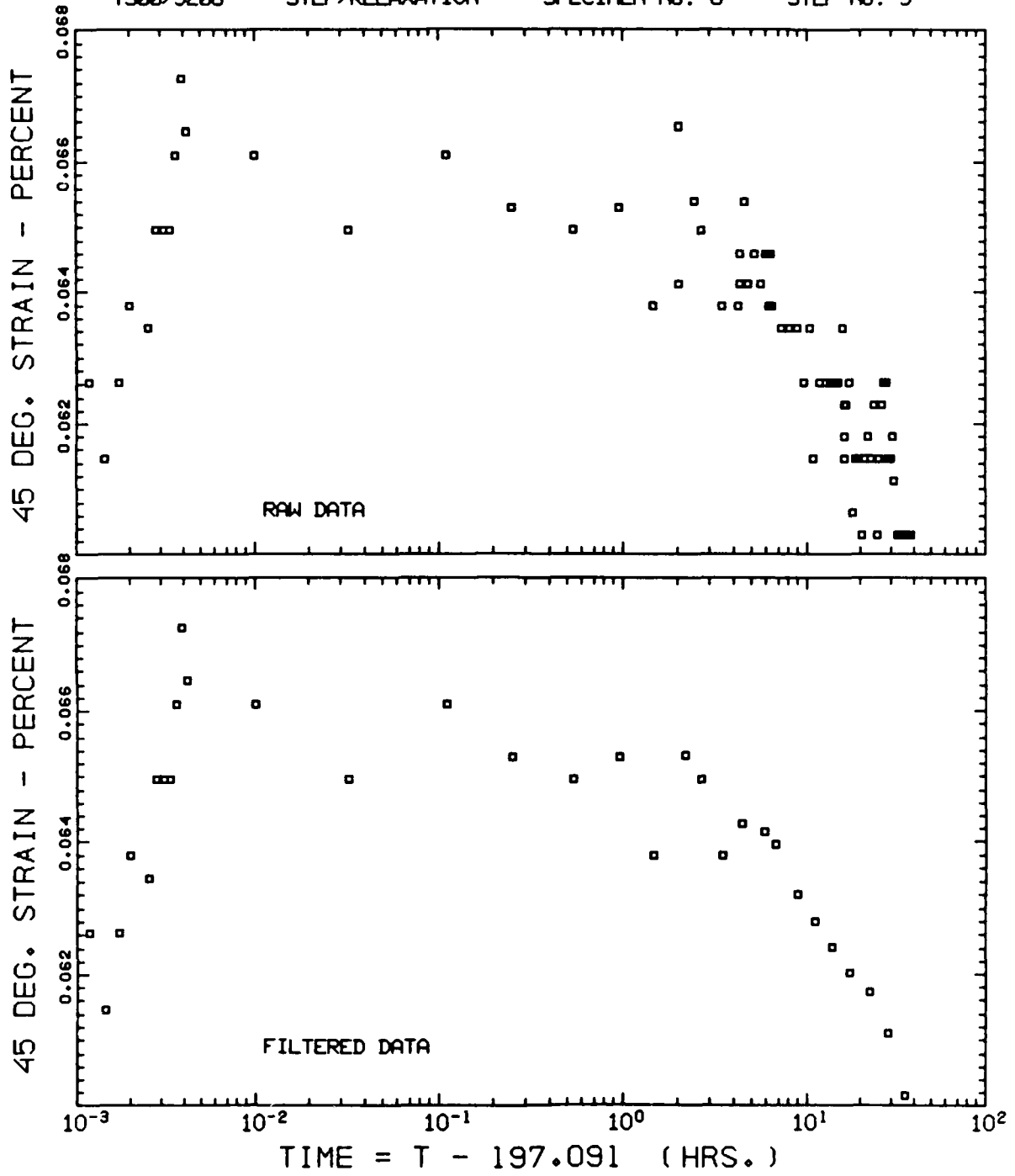

T300/5208 - STEP/RELAXATION - SPECIMEN No. 8 - STEP No. 6

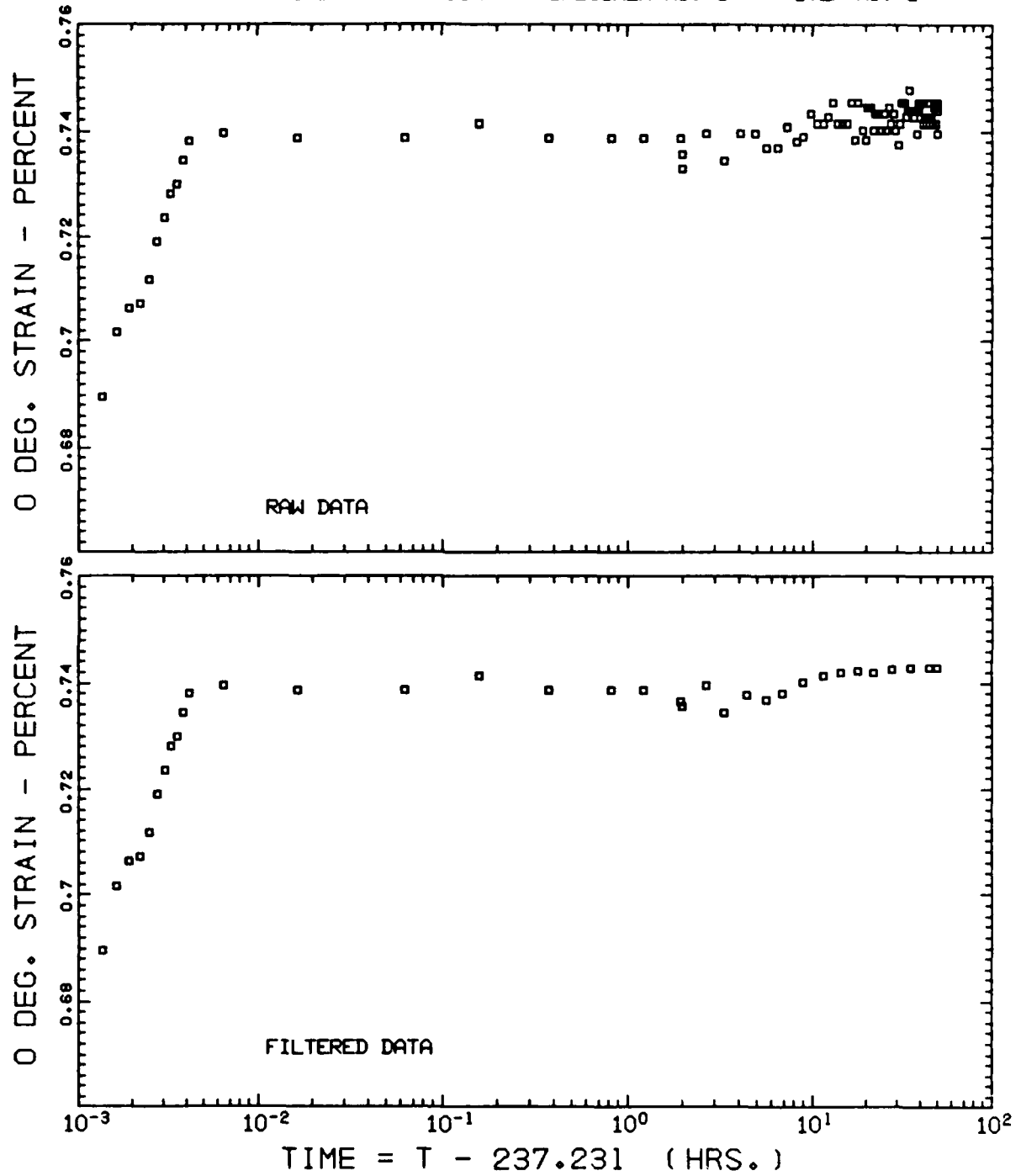

T300/5208 - STEP/RELAXATION - SPECIMEN No. 8 - STEP No. 6

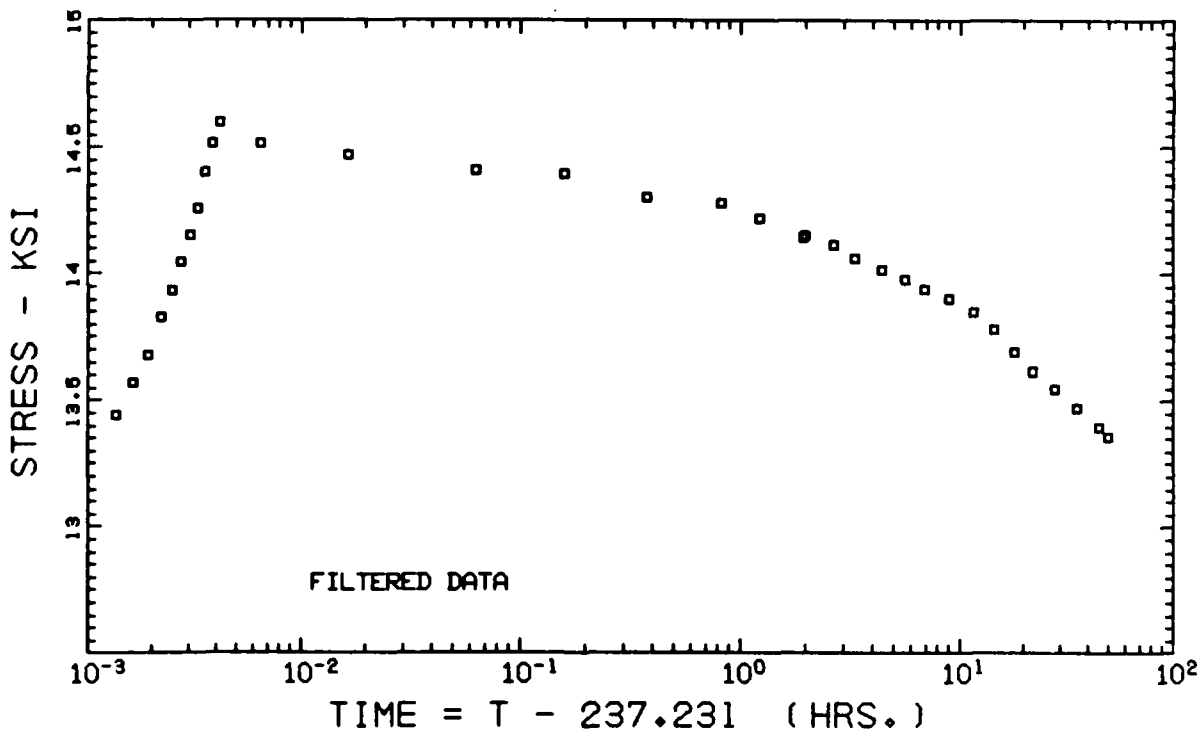
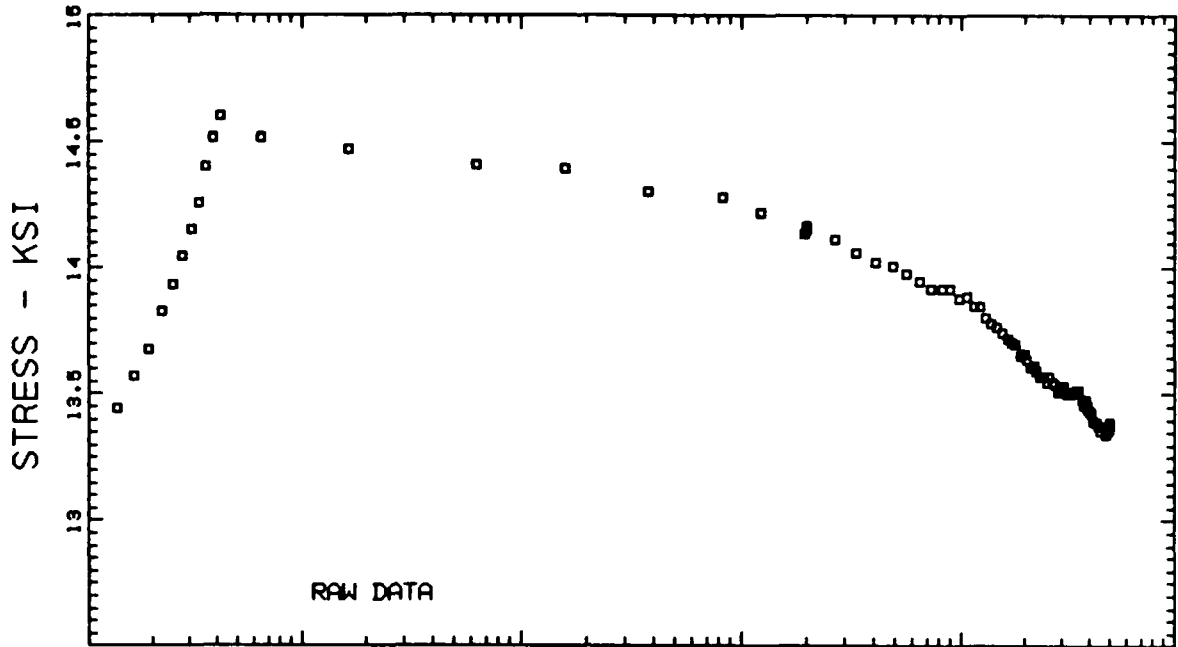

T300/5208 - STEP/RELAXATION - SPECIMEN No. 8 - STEP No. 6

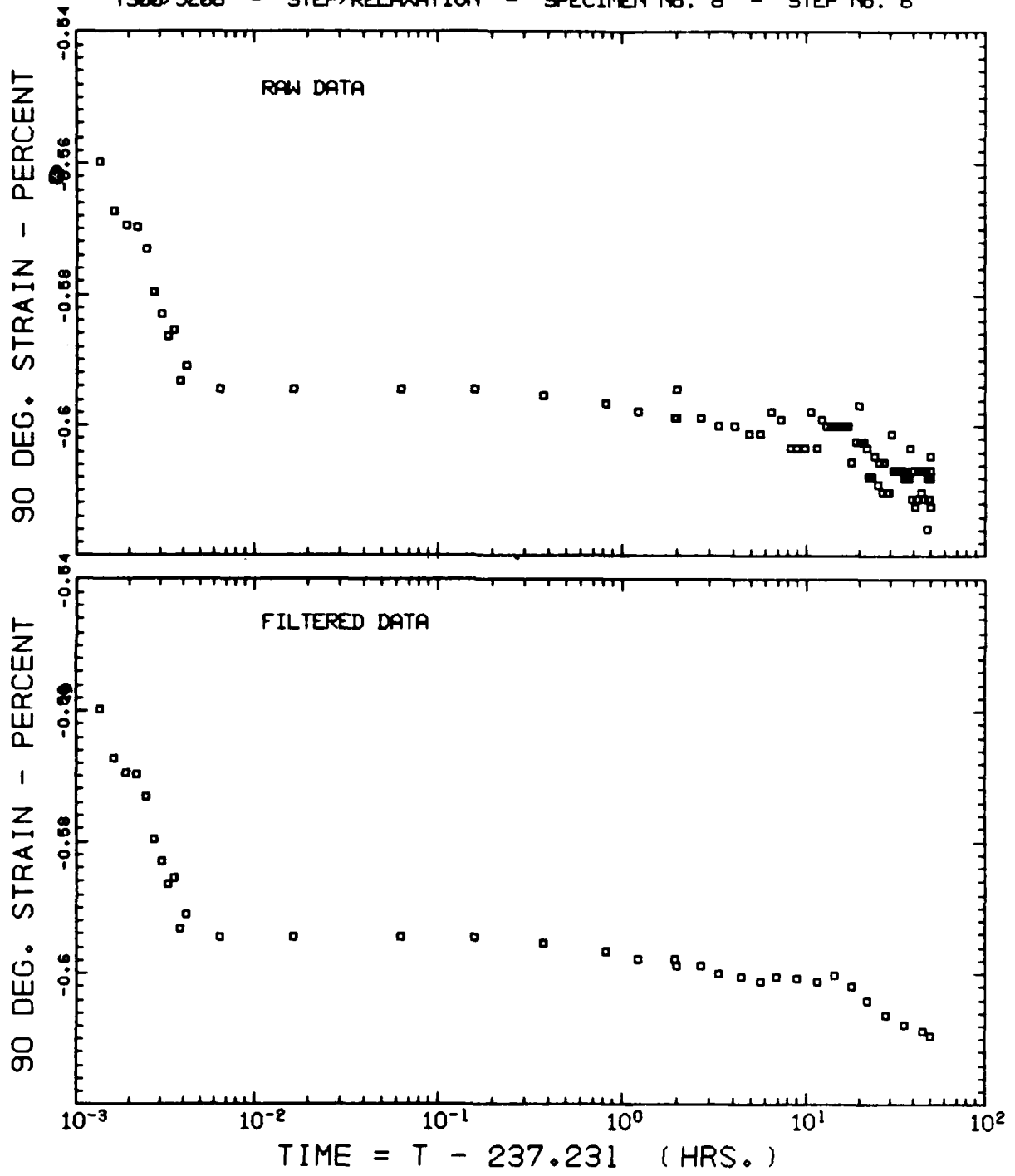

T300/5208 - STEP/RELAXATION - SPECIMEN No. 8 - STEP No. 6

45 DEG. STRAIN - PERCENT

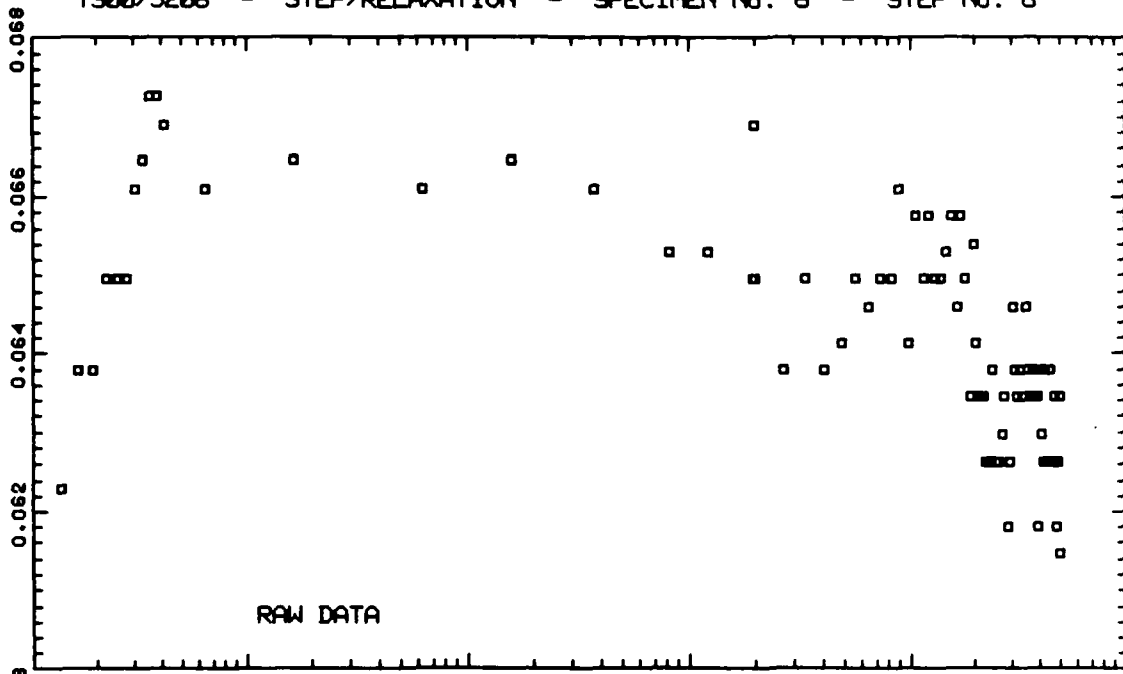

45 DEG. STRAIN - PERCENT

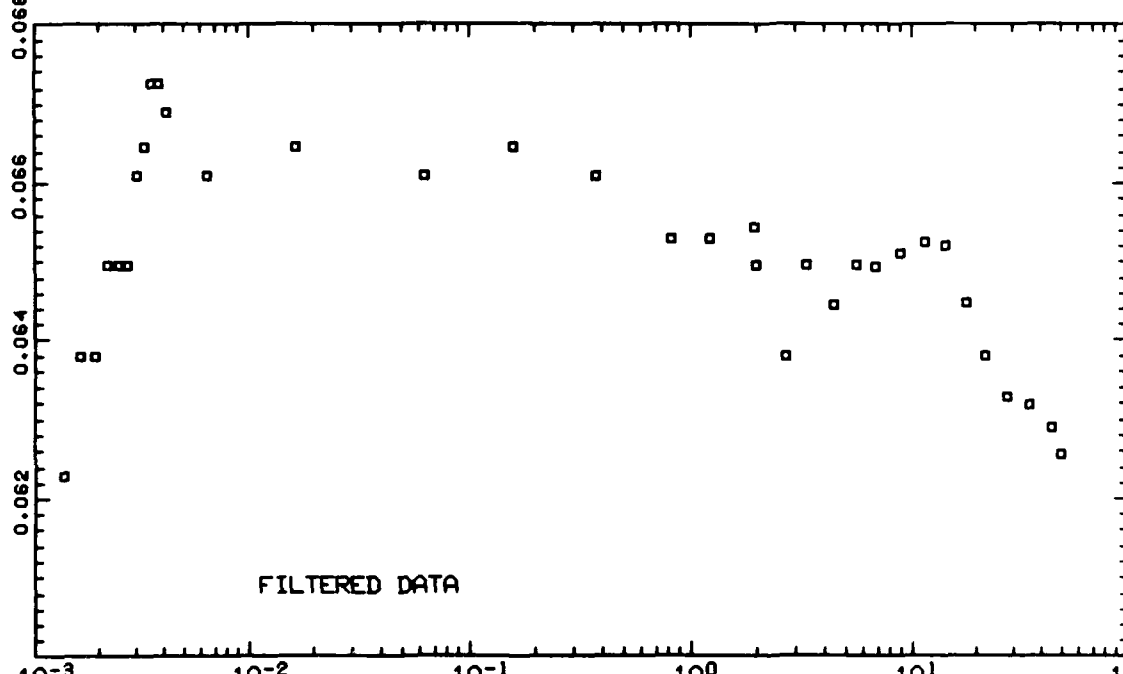

TIME = T - 237.231 (HRS.)

T300/5208 - STEP/RELAXATION - SPECIMEN No. 8 - STEP No. 7

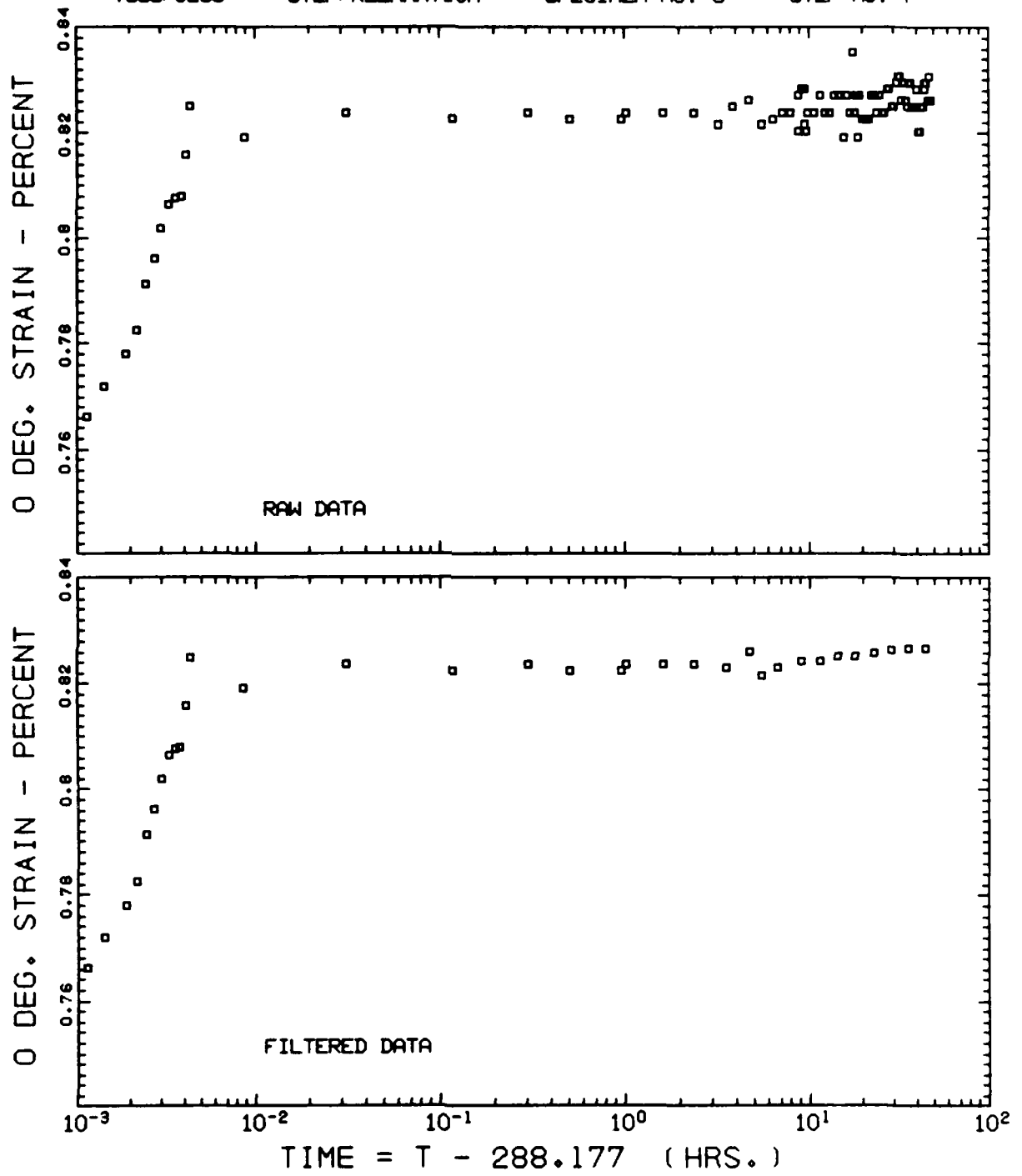

T300/S208 - STEP/RELAXATION - SPECIMEN No. 8 - STEP No. 7

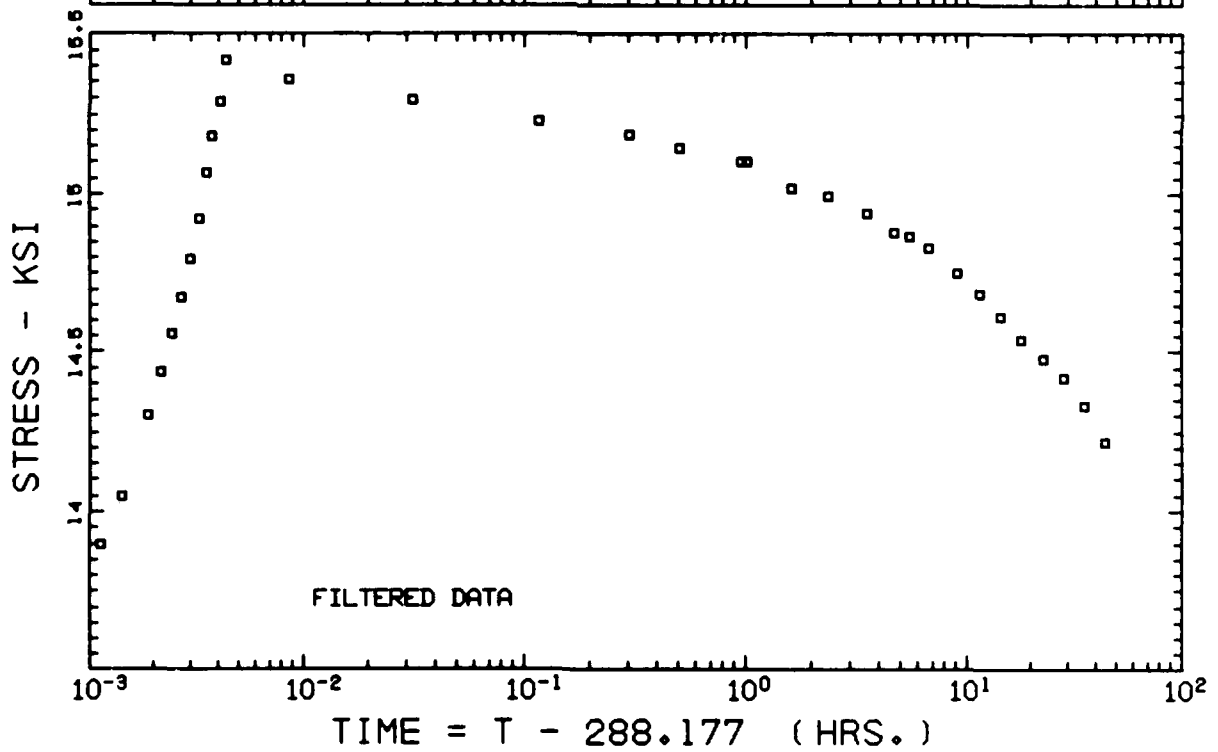
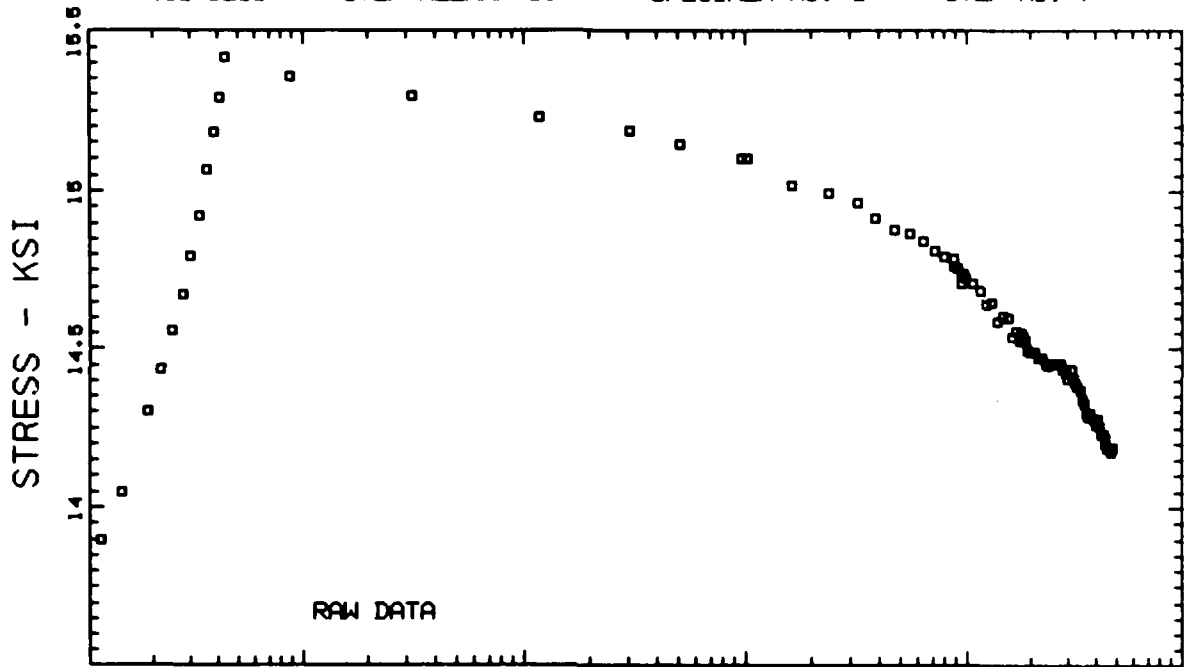



T300/S208 - STEP/RELAXATION - SPECIMEN No. 8 - STEP No. 7

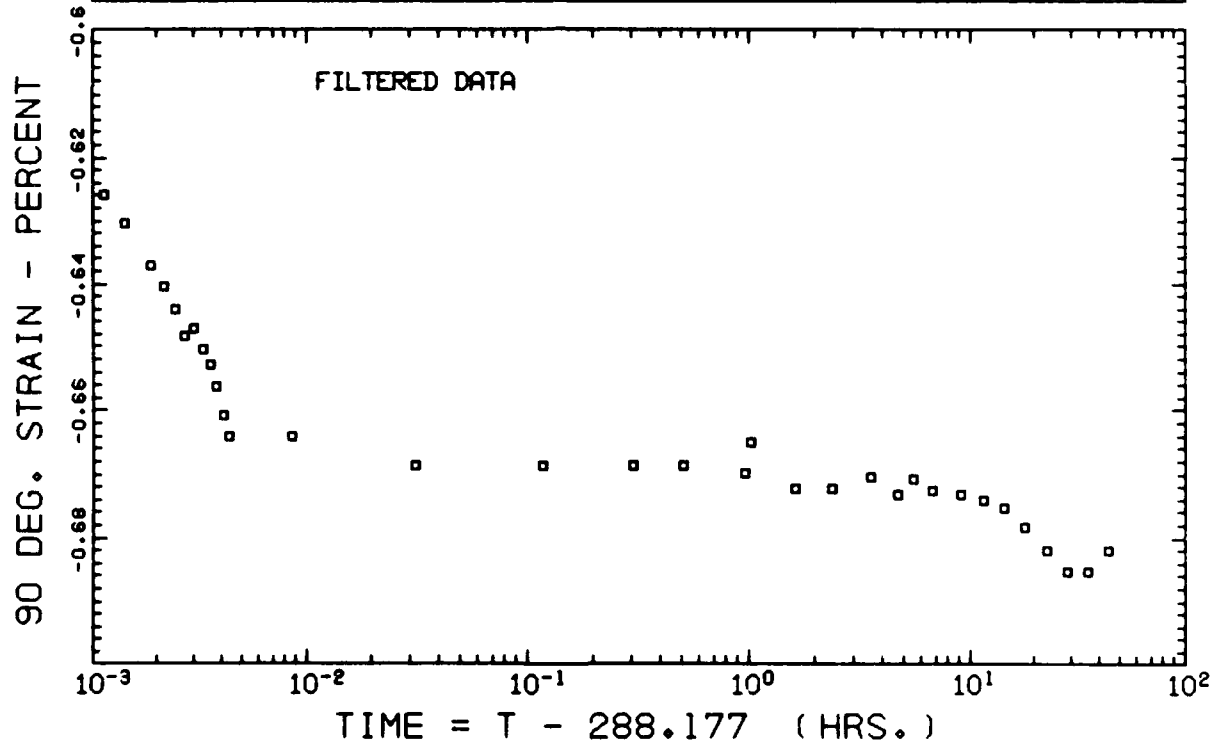
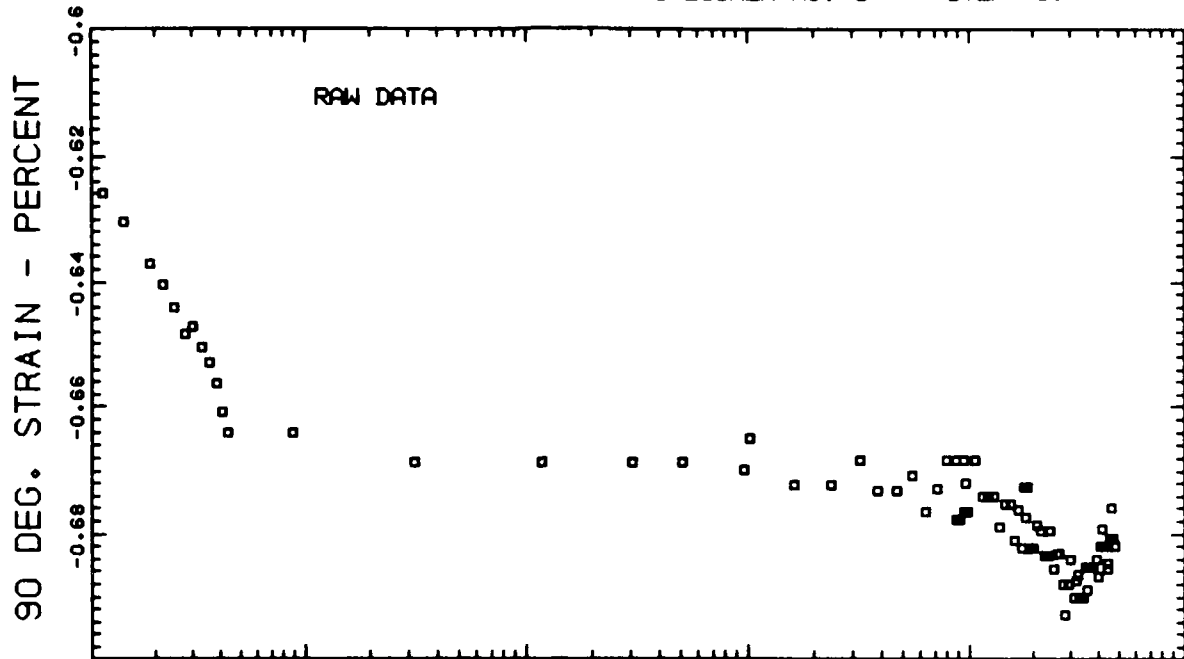

T300/5208 - STEP/RELAXATION - SPECIMEN No. 8 - STEP No. 7

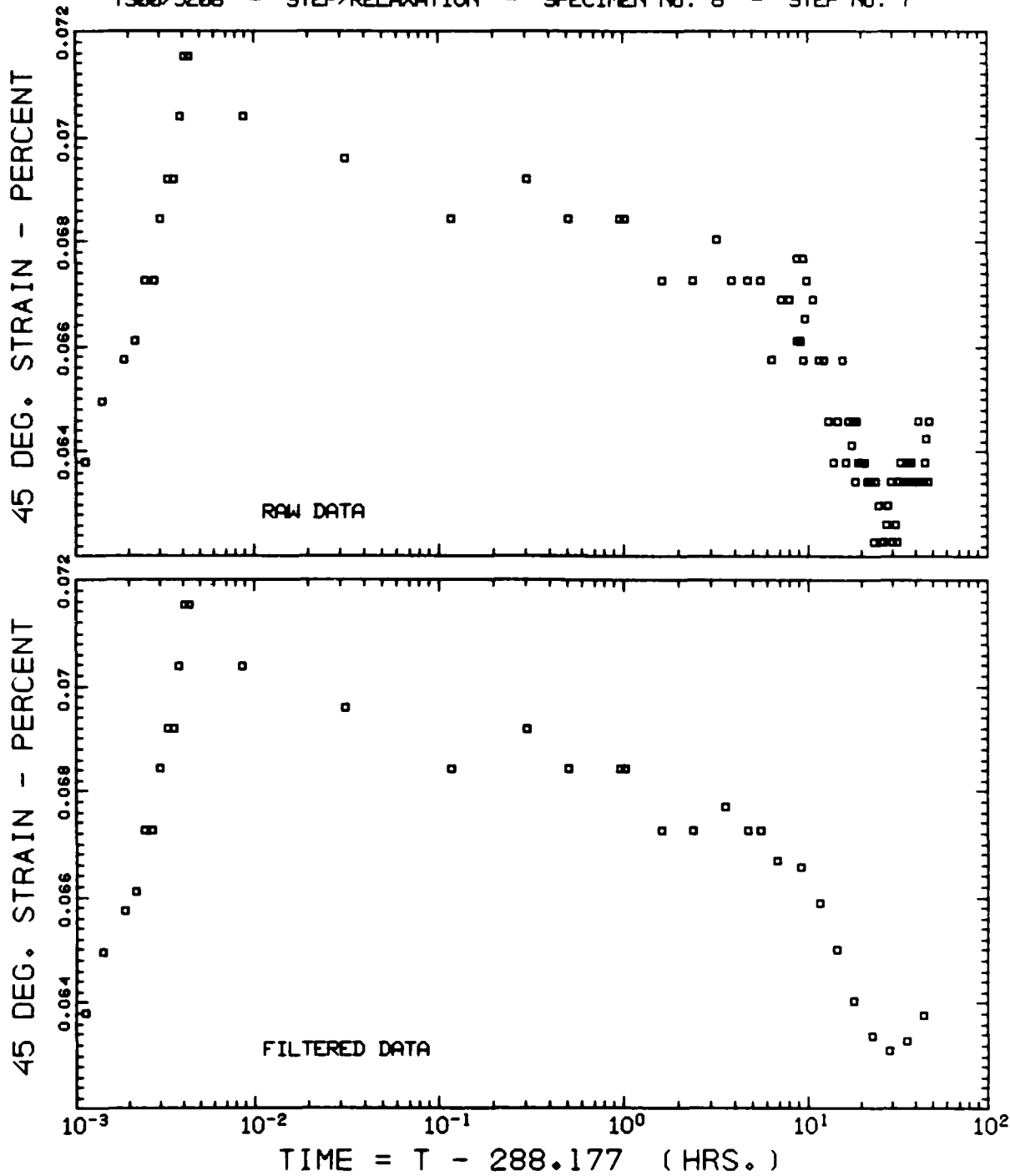

T300/5208 - STEP/RELAXATION - SPECIMEN No. 8 - STEP No. 8

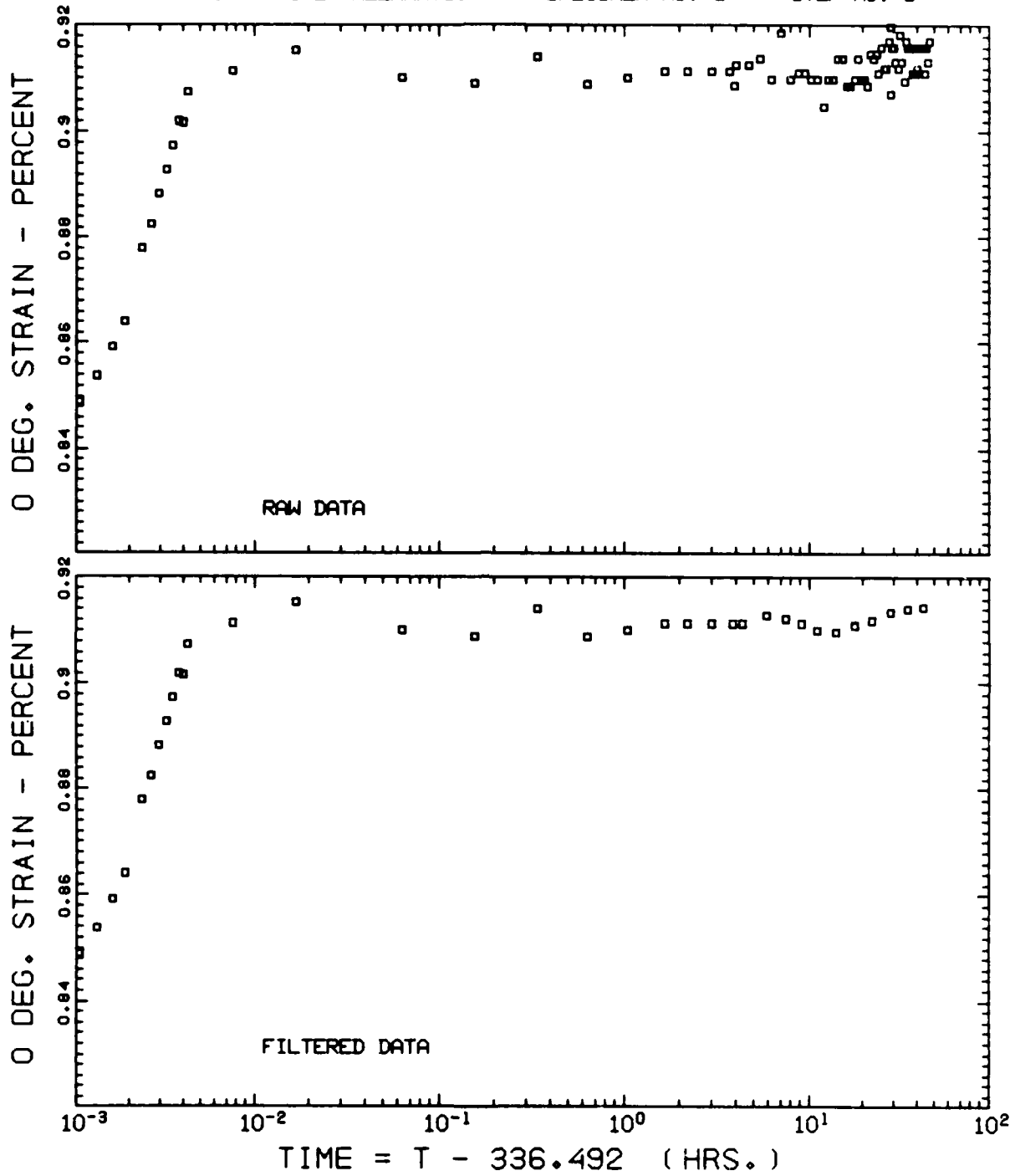

T300/5208 - STEP/RELAXATION - SPECIMEN No. 8 - STEP No. 8

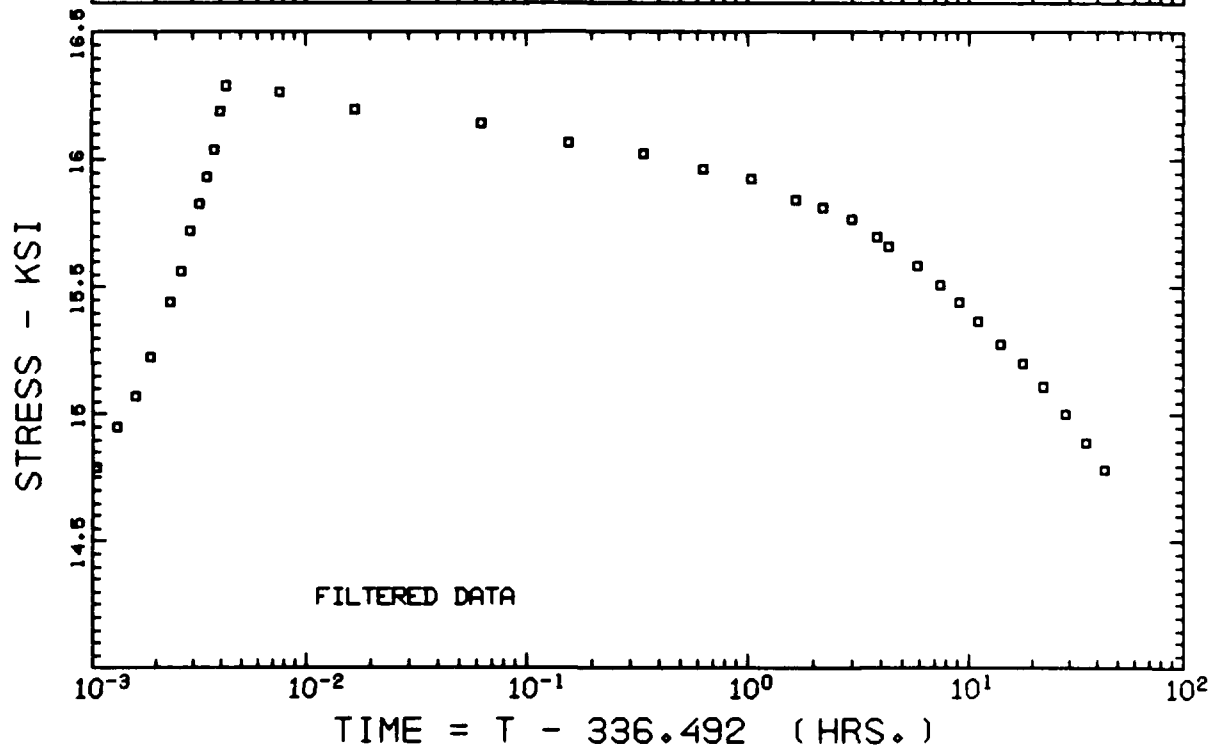
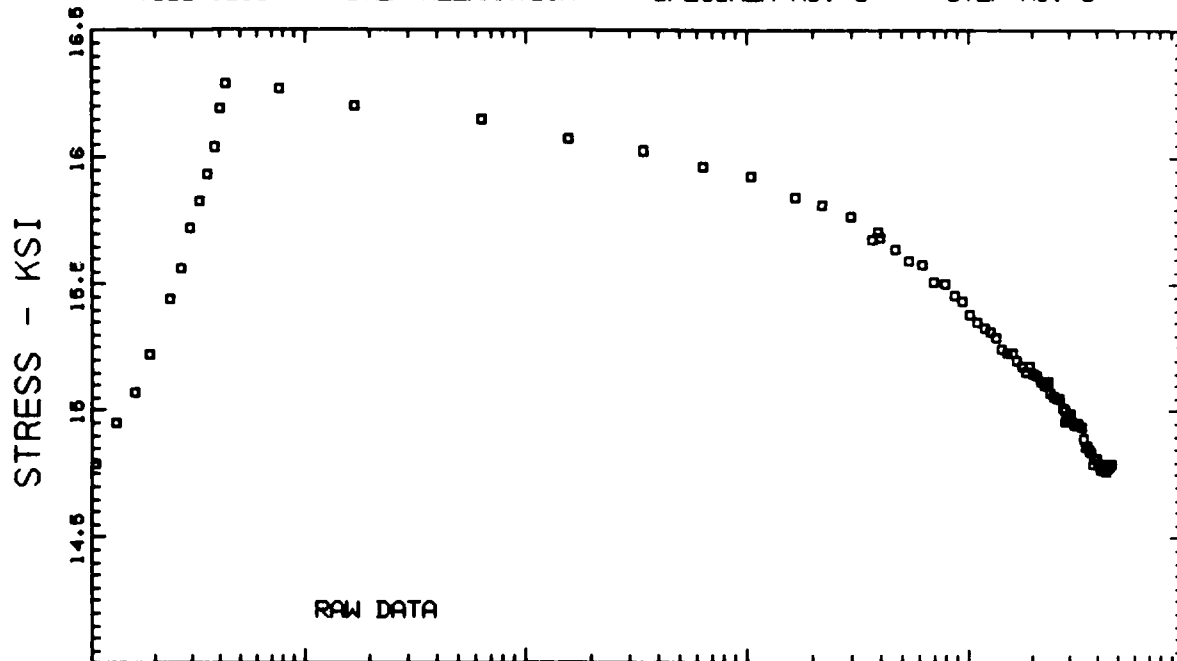

T300/5208 - STEP/RELAXATION - SPECIMEN No. 8 - STEP No. 8

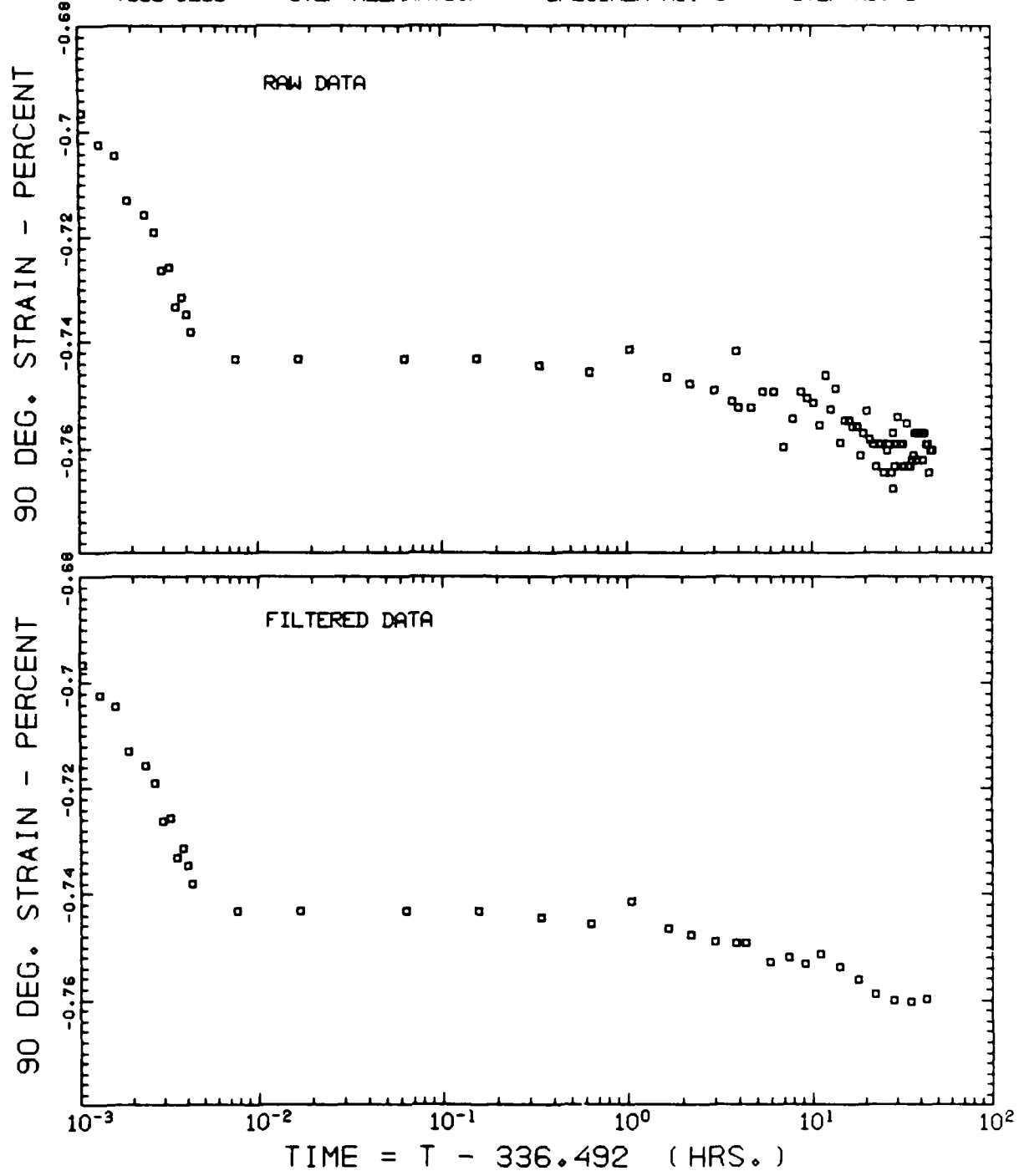

T300/5208 - STEP/RELAXATION - SPECIMEN No. 8 - STEP No. 8

45 DEG. STRAIN - PERCENT

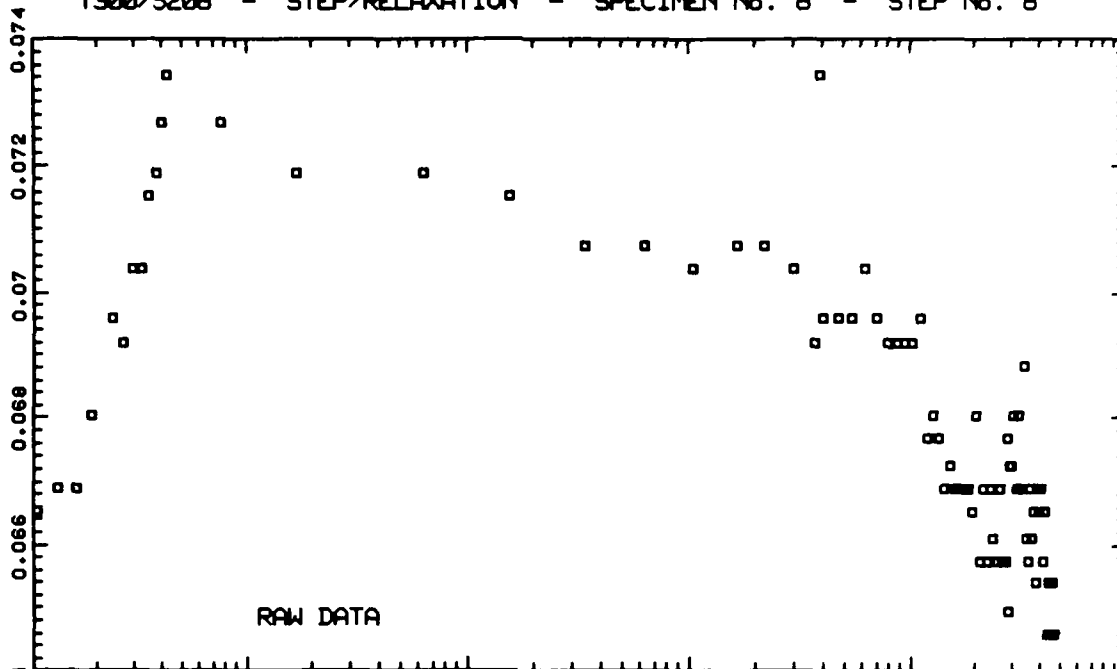

45 DEG. STRAIN - PERCENT

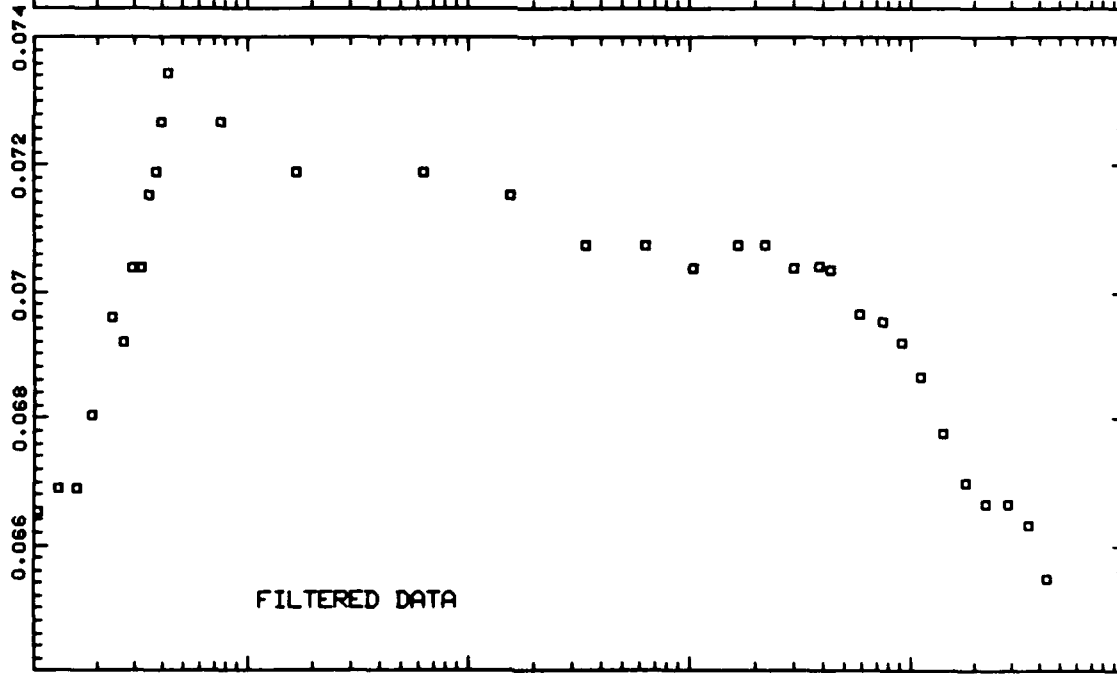

TIME = T - 336.492 (HRS.)

T300/5208 - STEP/RELAXATION - SPECIMEN No. 8 - STEP No. 9

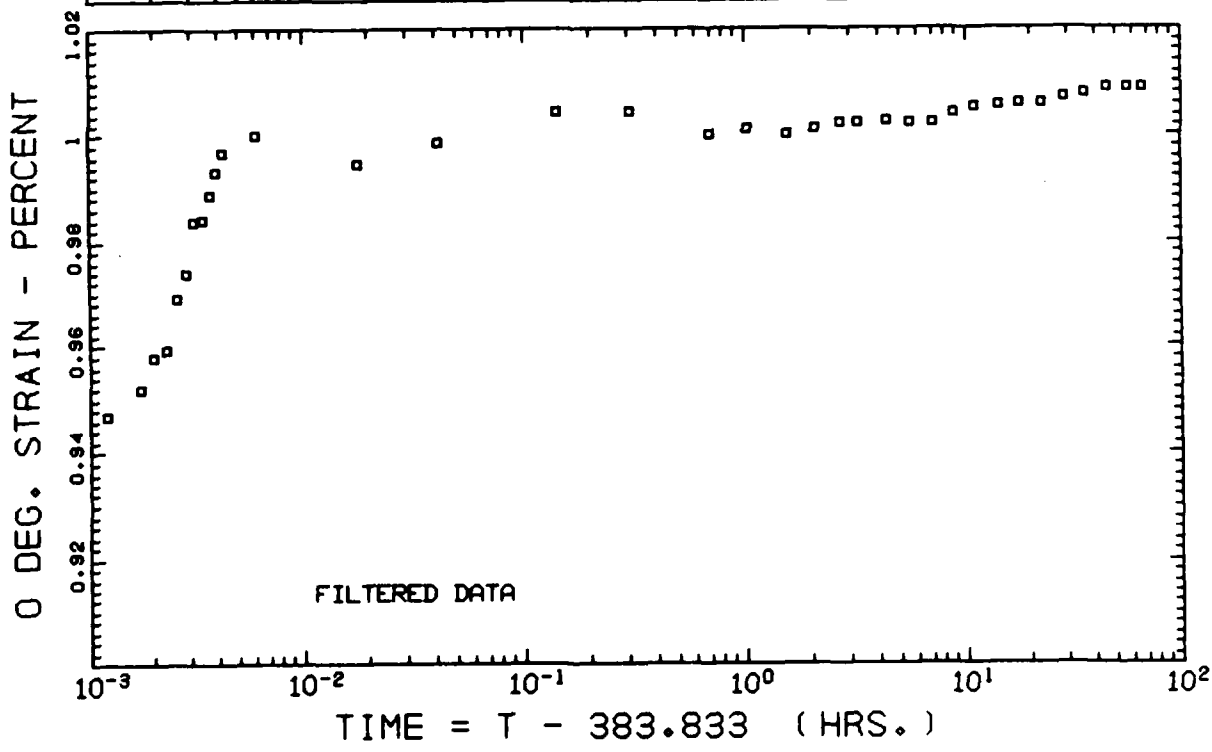
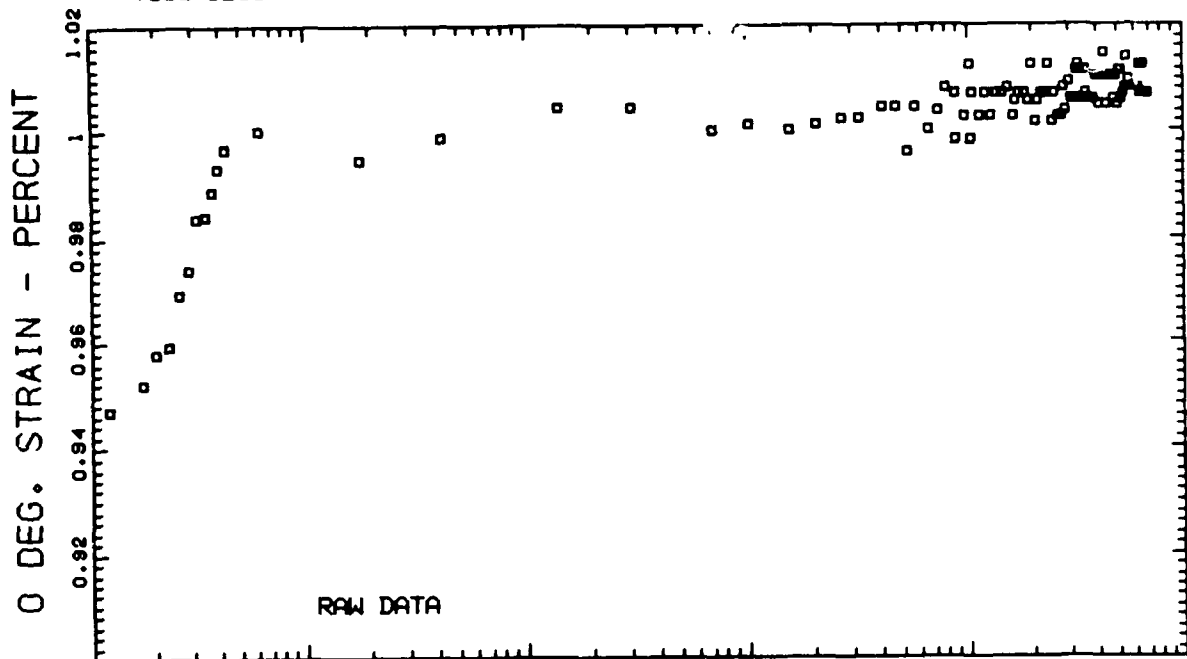

T300/52081 - STEP/RELAXATION - SPECIMEN No. 8 - STEP No. 9

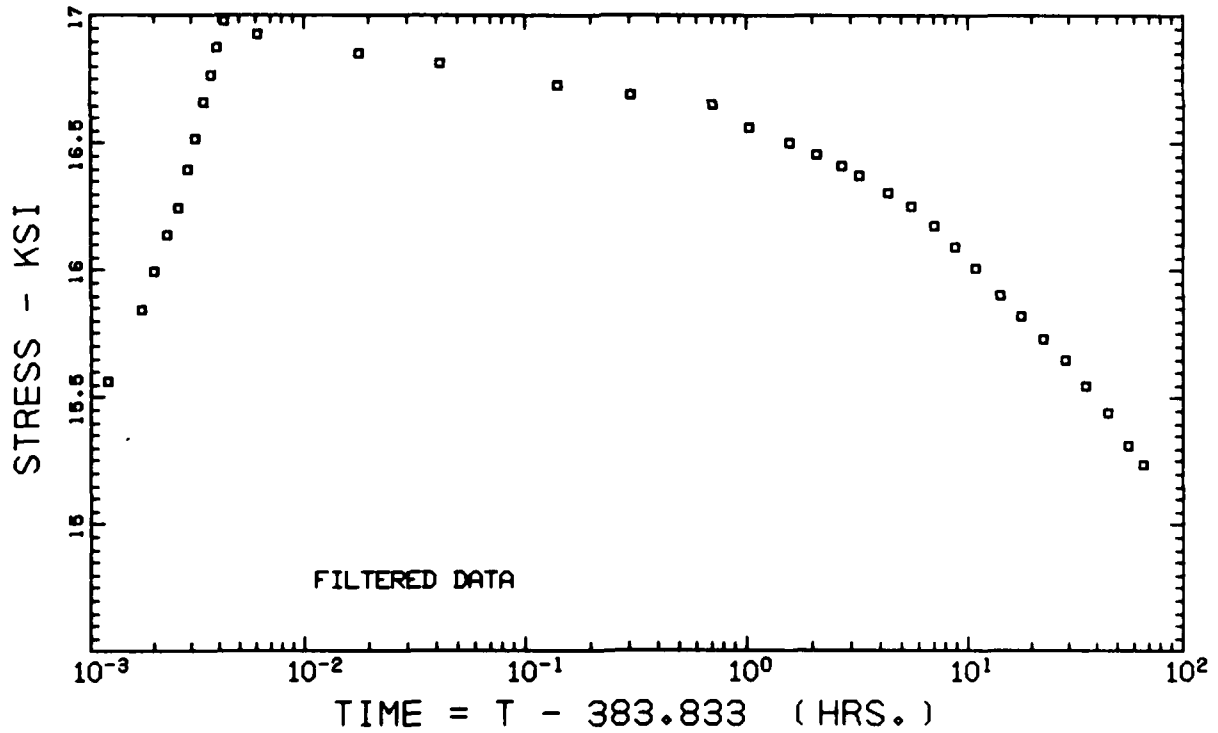
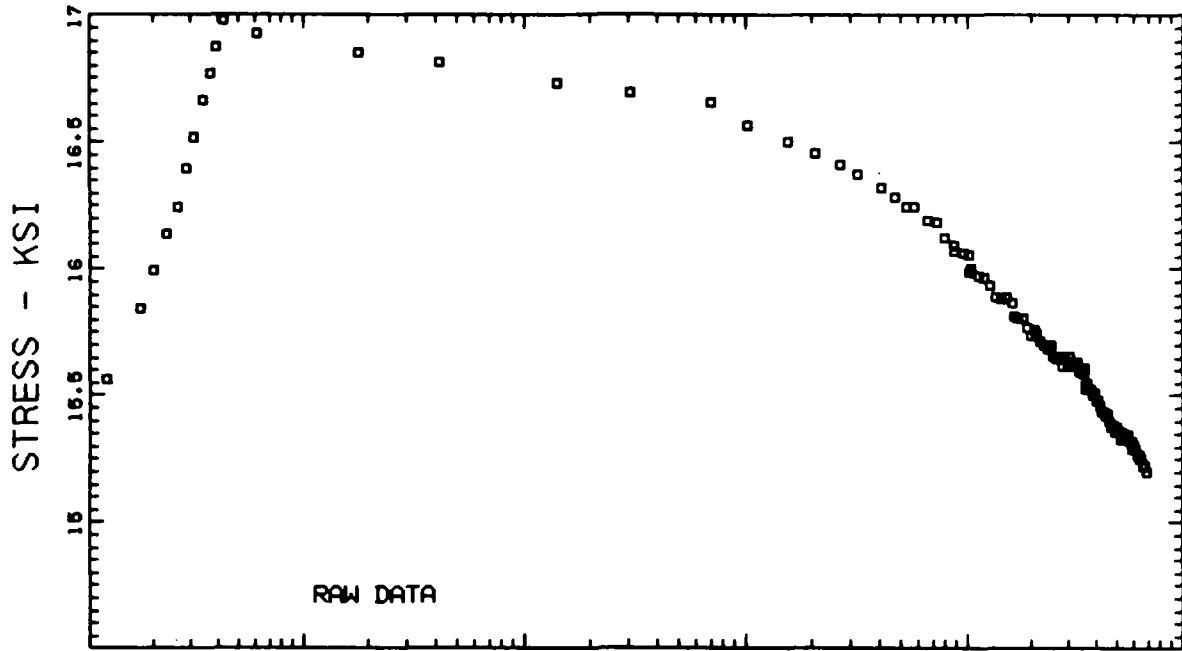



T300/S208 - STEP/RELAXATION - SPECIMEN No. 8 - STEP No. 9

90 DEG. STRAIN - PERCENT

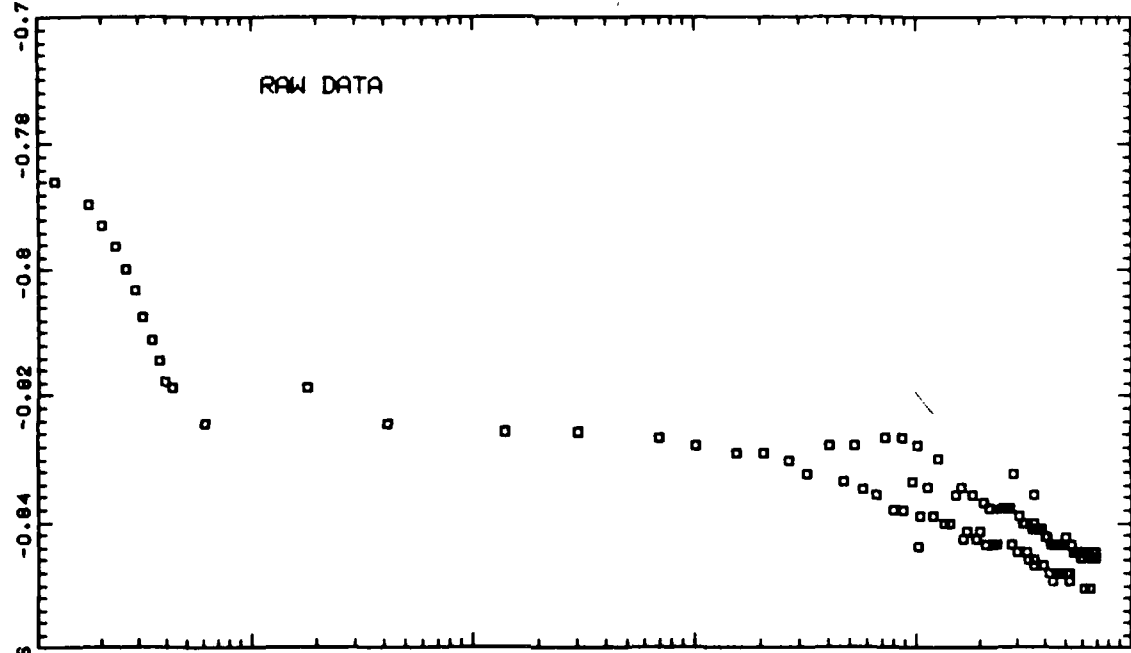

90 DEG. STRAIN - PERCENT

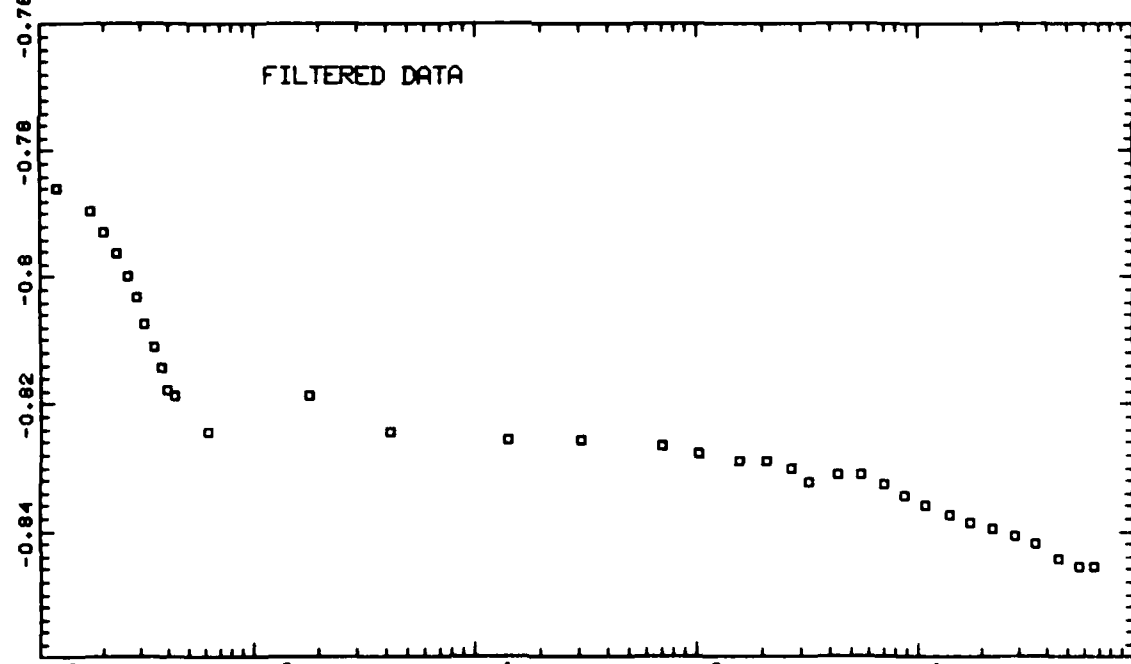

TIME = T - 383.833 (HRS.)

T300/5208 - STEP/RELAXATION - SPECIMEN No. 8 - STEP No. 9

45 DEG. STRAIN - PERCENT

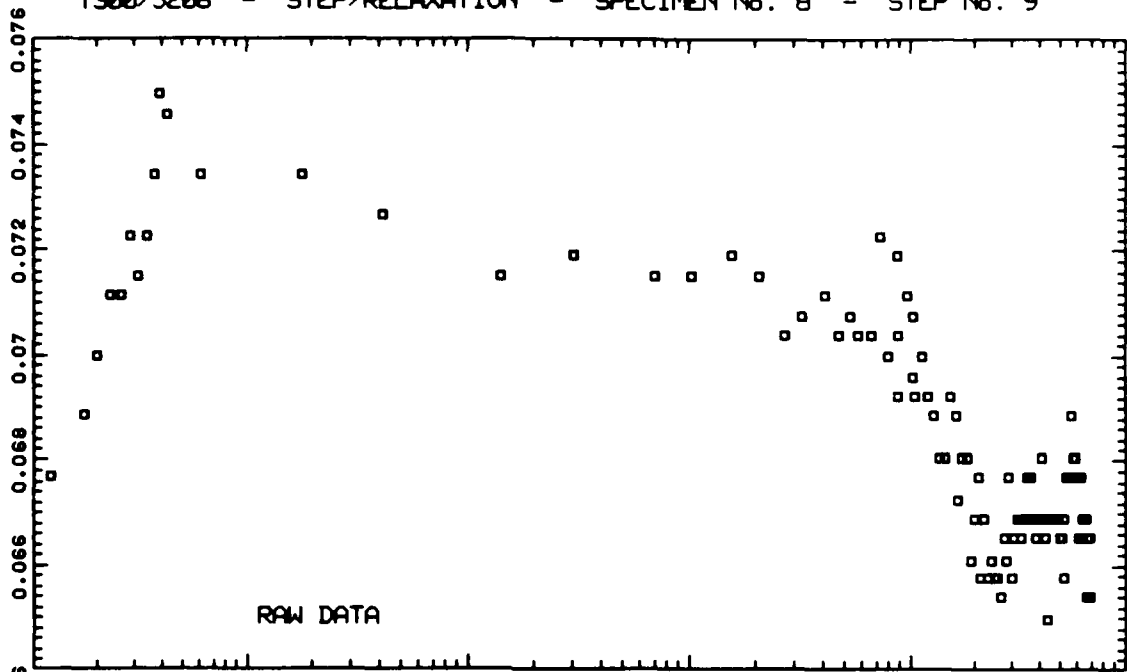

45 DEG. STRAIN - PERCENT

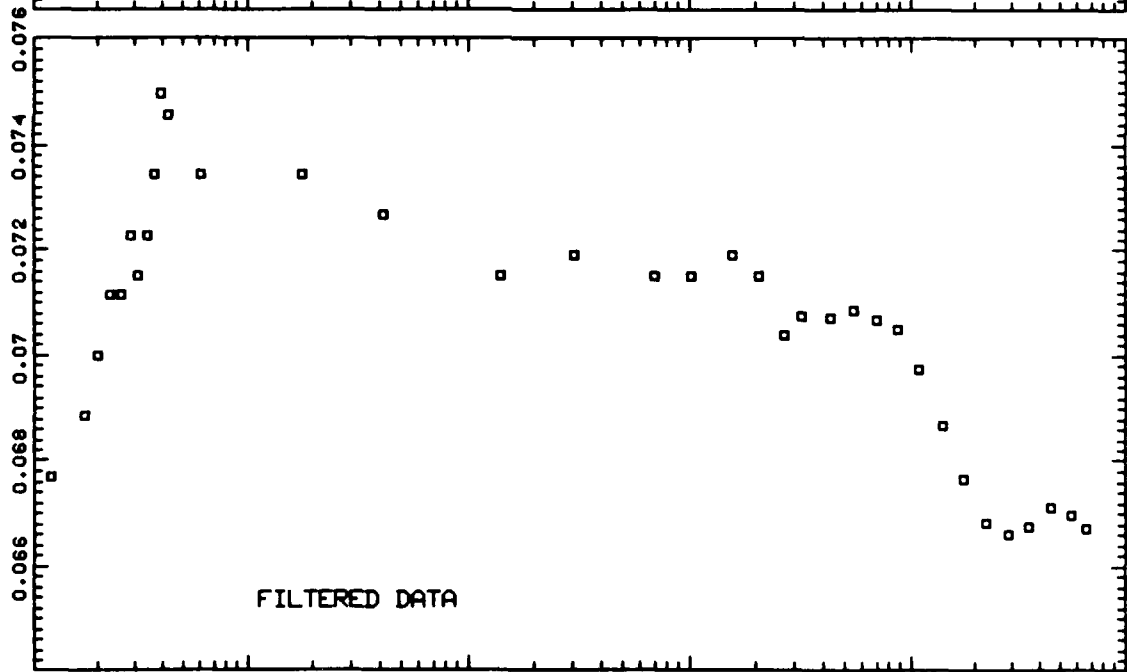

TIME = T - 383.833 (HRS.)

T300/S208 - STEP/RELAXATION - SPECIMEN No. 8 - STEP No. 10

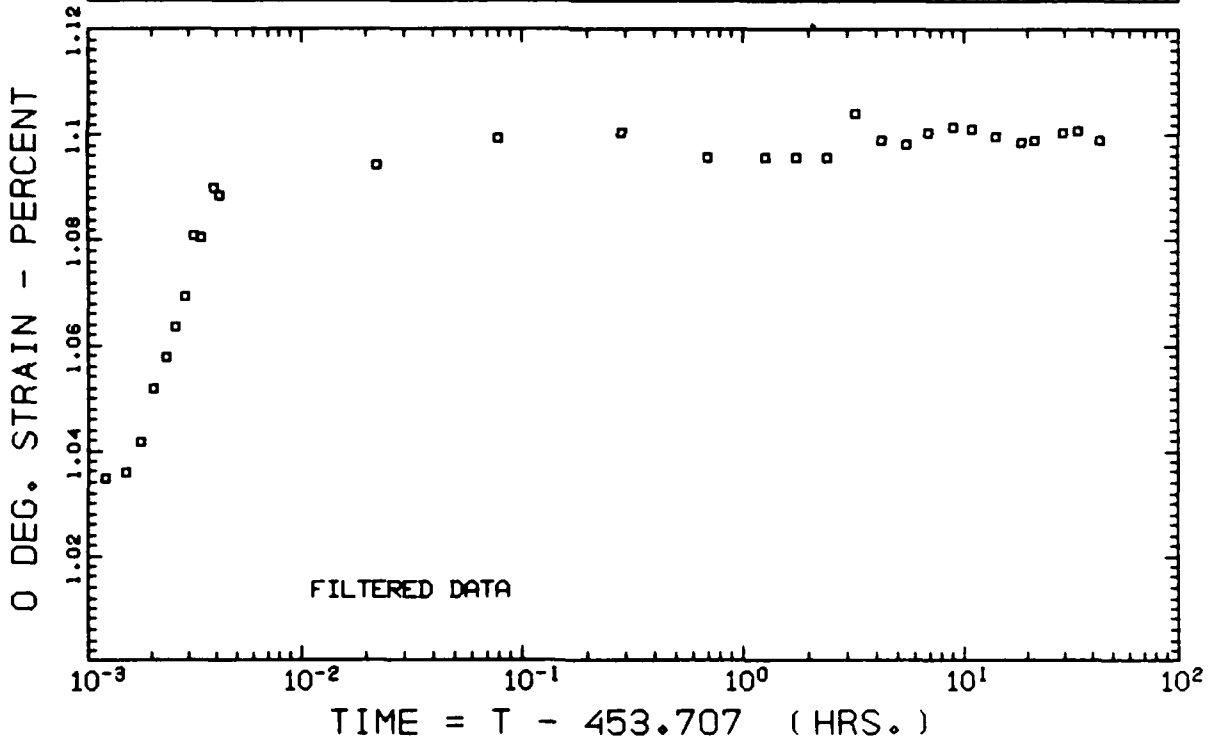
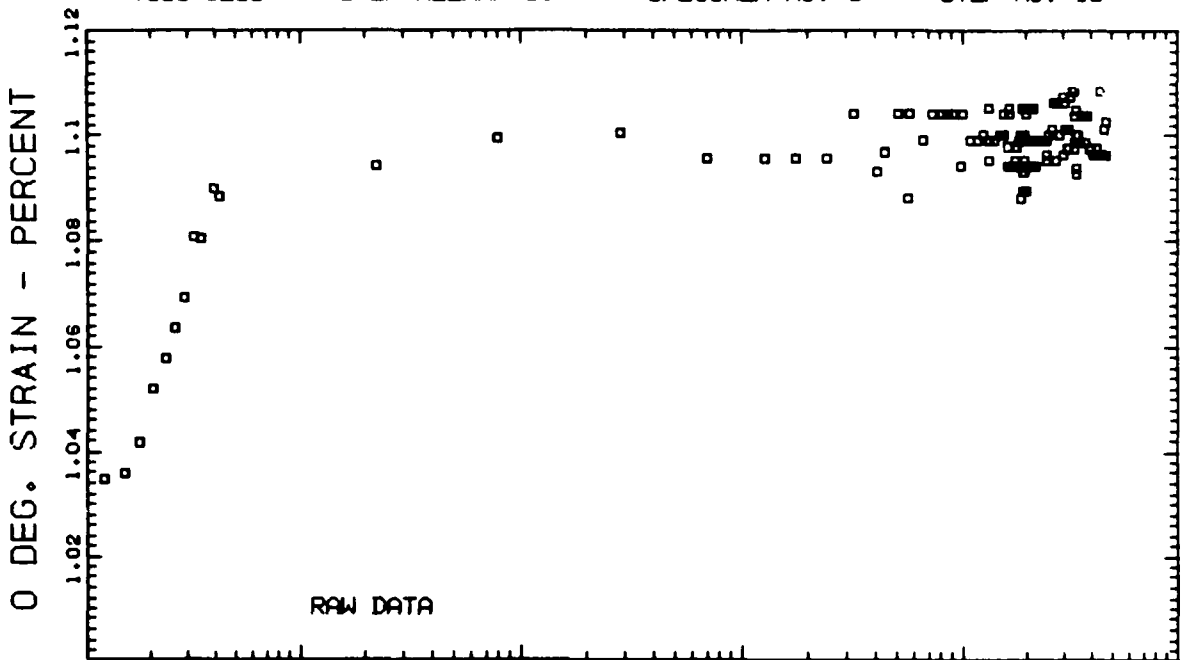

T300/5208 - STEP/RELAXATION - SPECIMEN No. 8 - STEP No. 10

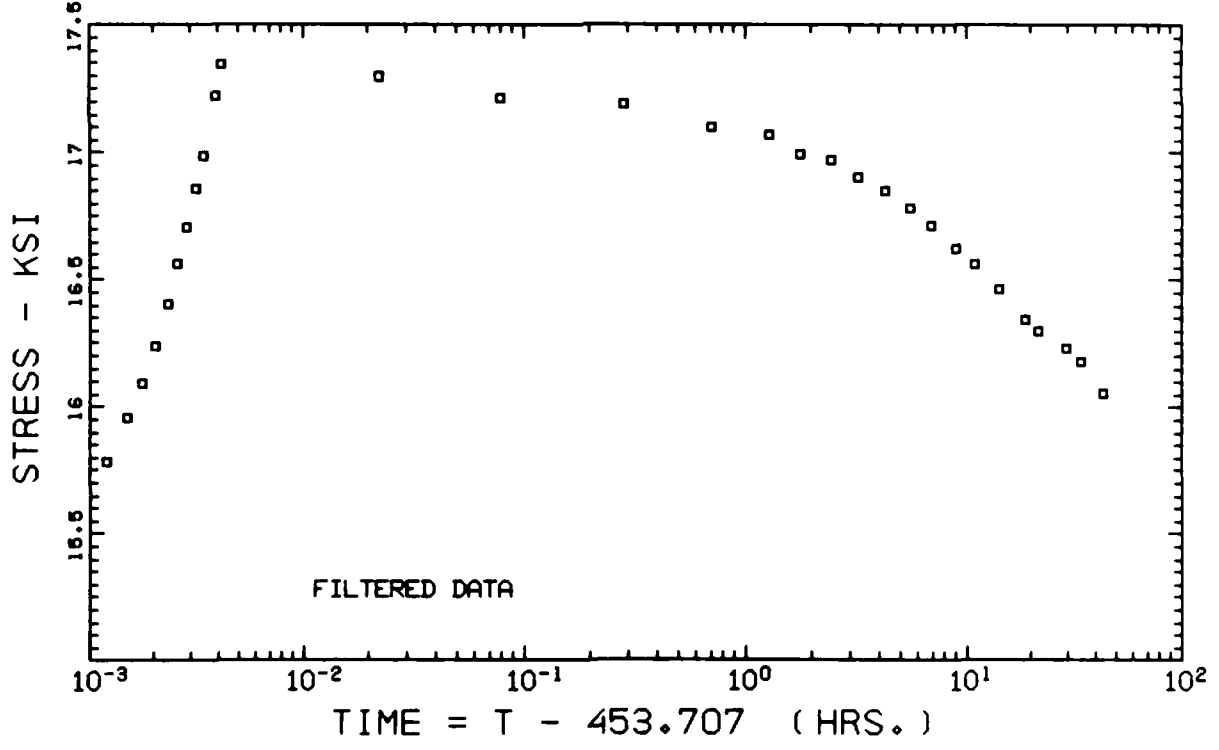
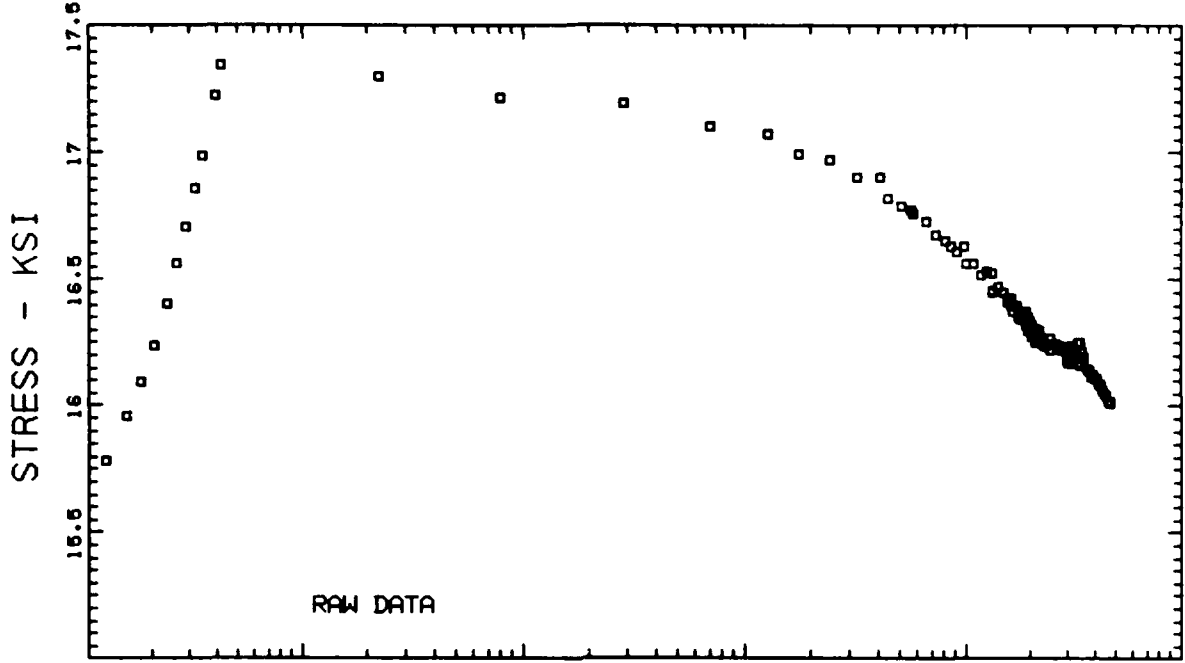

T300/5208 - STEP/RELAXATION - SPECIMEN No. 8 - STEP No. 10

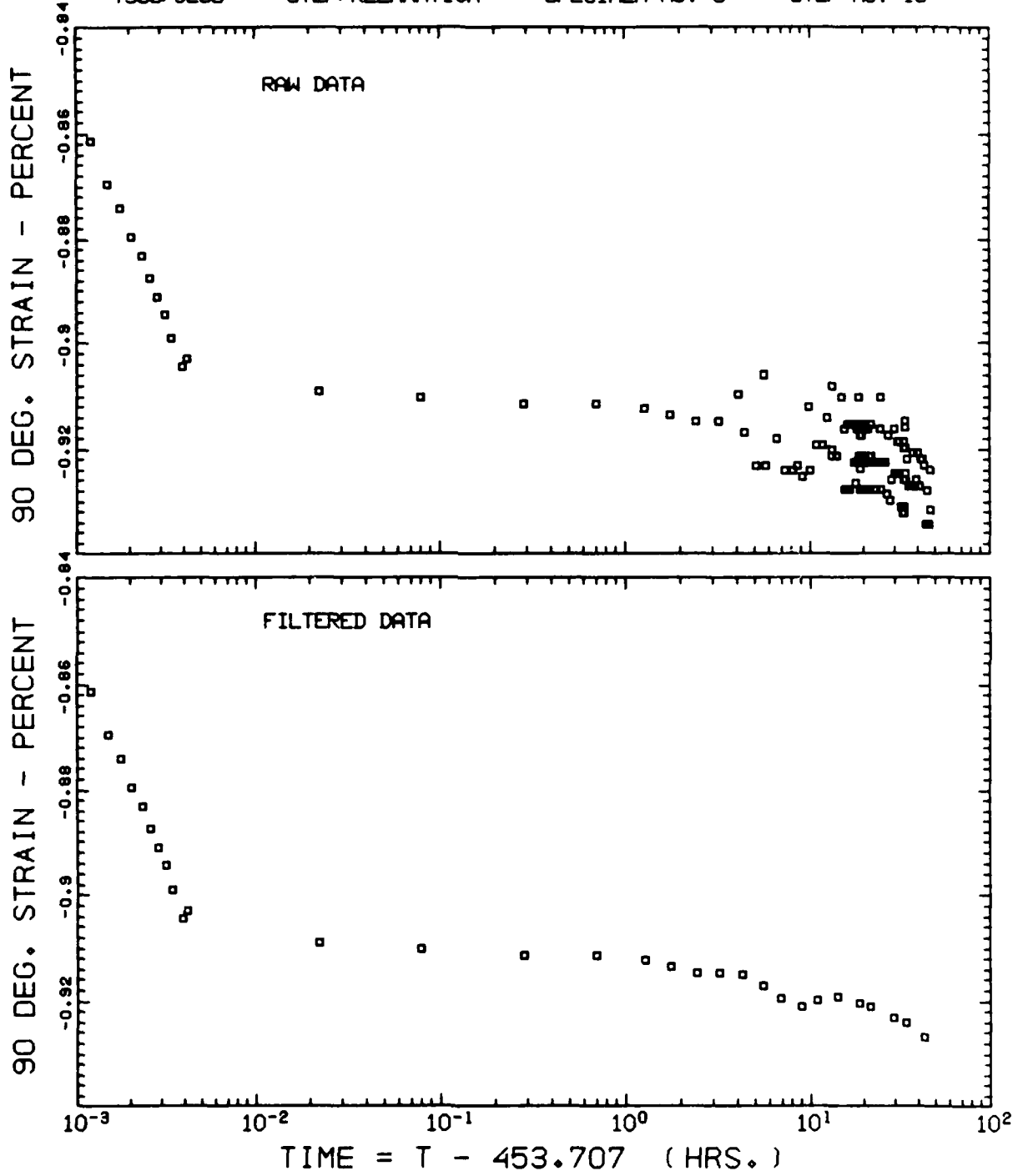

T300/S208 - STEP/RELAXATION - SPECIMEN No. 8 - STEP No. 10

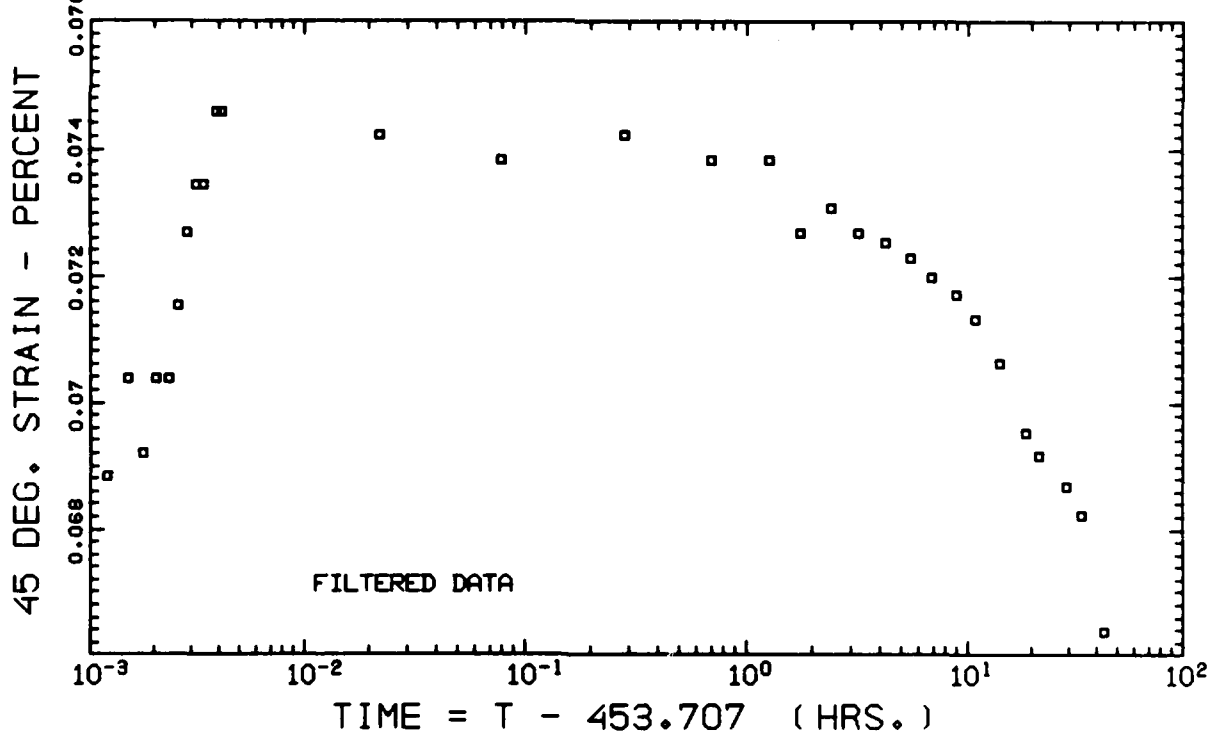
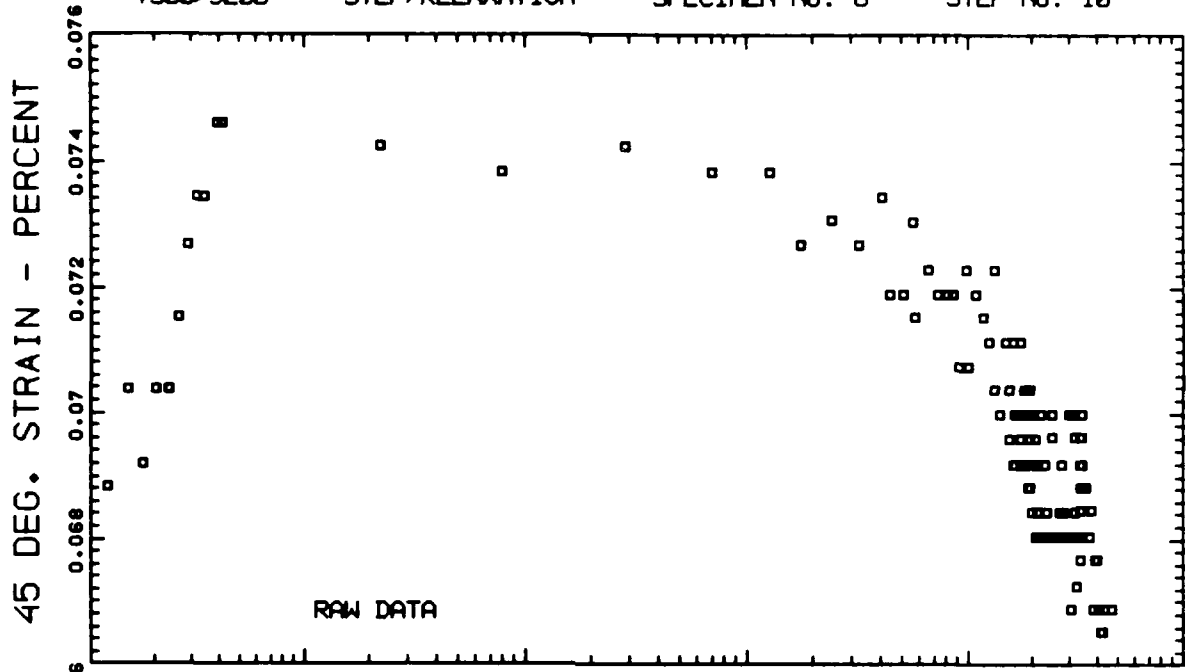

T300/5208 - STEP/RELAXATION - SPECIMEN No. 8 - STEP No. 11

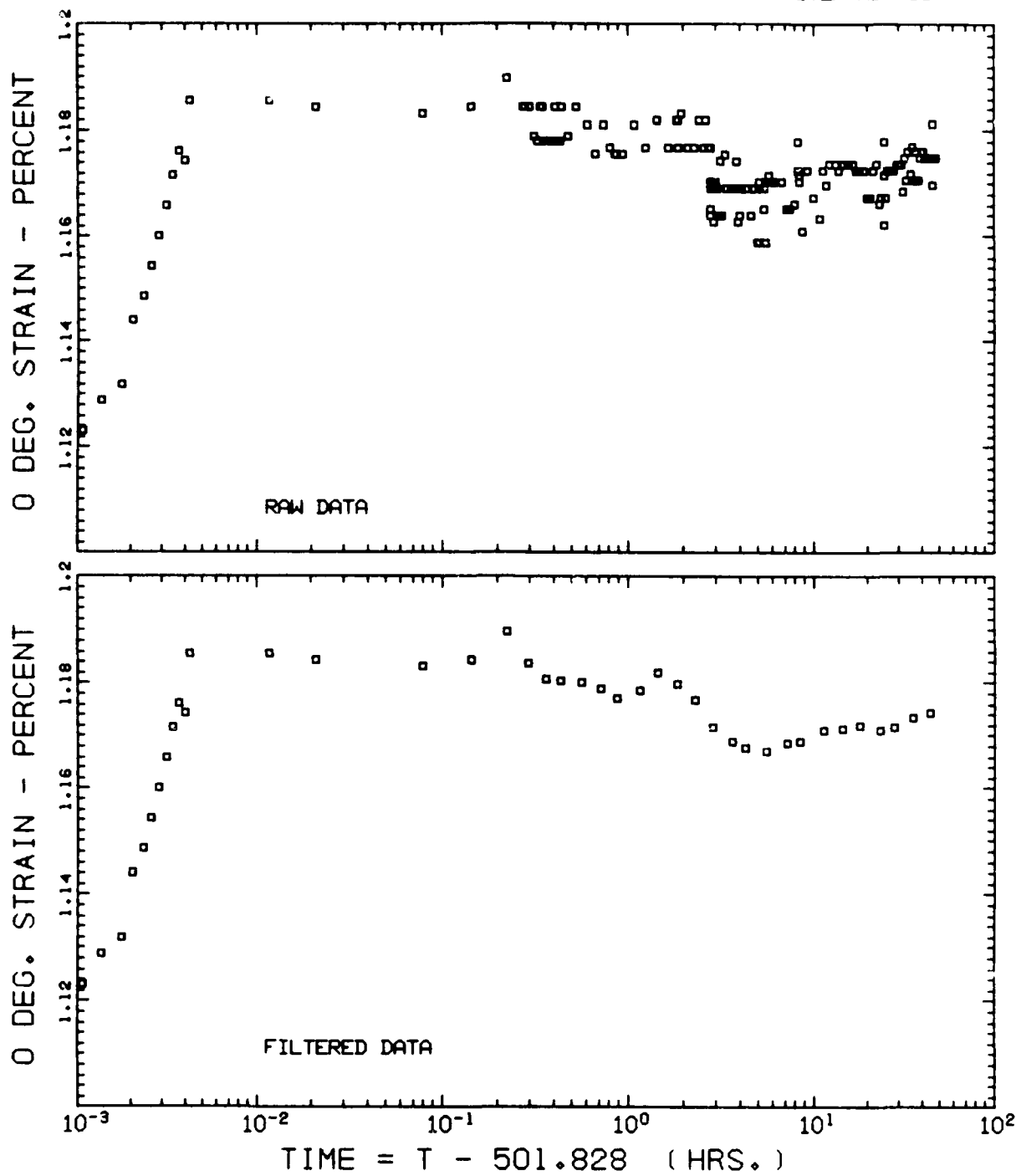

T300/5208 - STEP/RELAXATION - SPECIMEN No. 8 - STEP No. 11

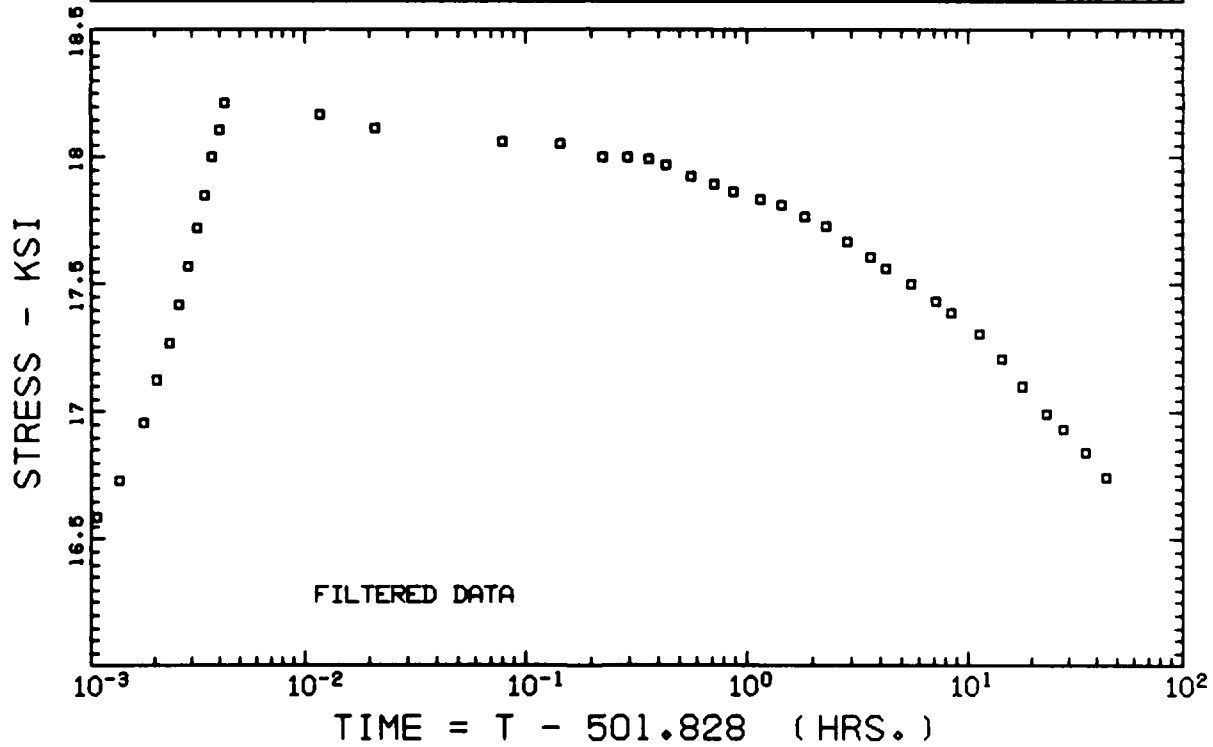
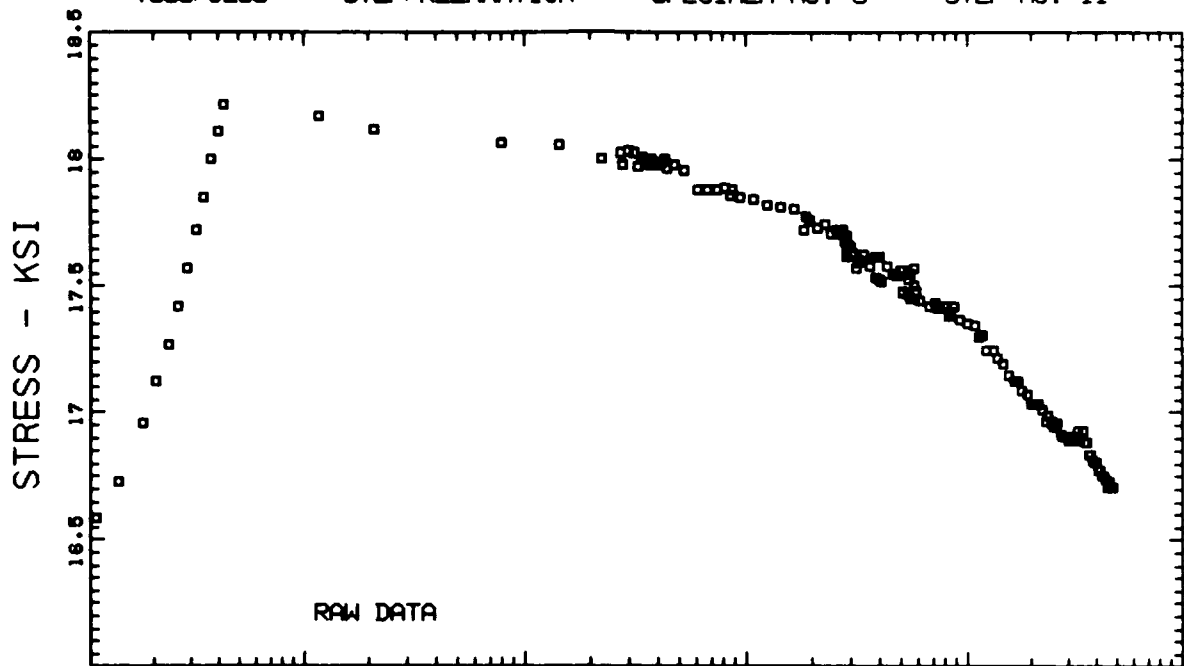



T300/5208 - STEP/RELAXATION - SPECIMEN No. 8 - STEP No. 11

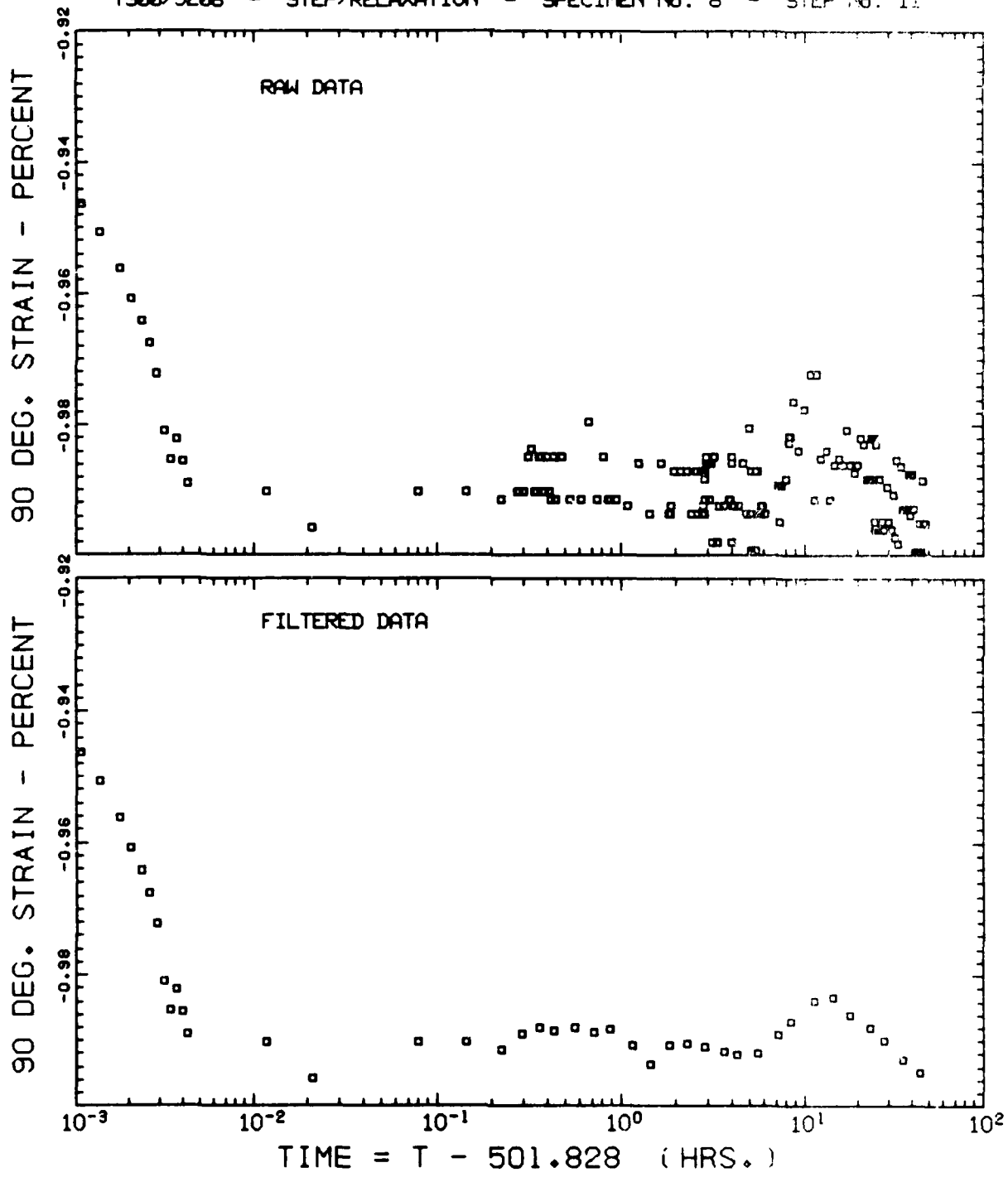

T300/5208 - STEP/RELAXATION - SPECIMEN No. 8 - STEP No. 11

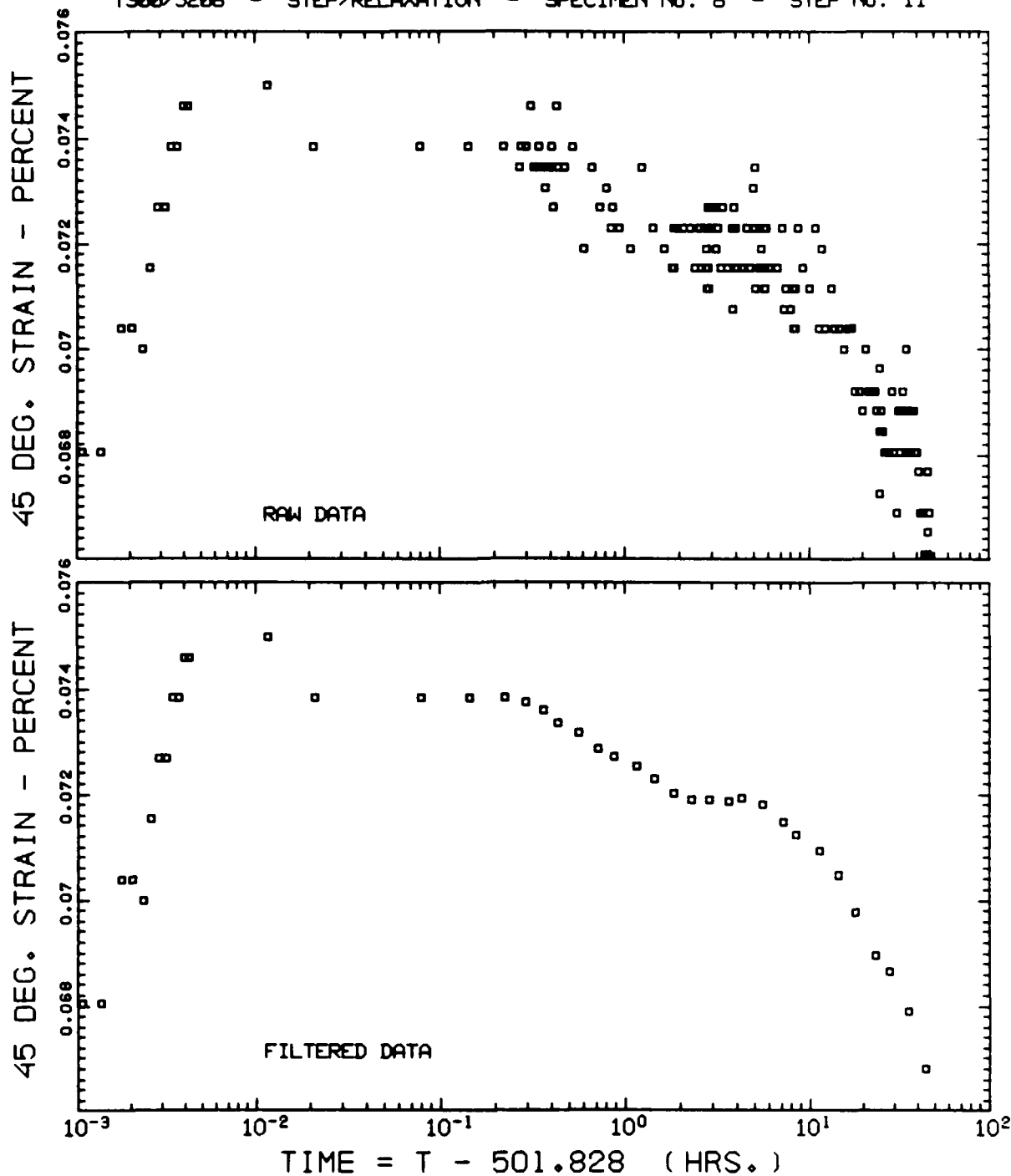

T300/5208 - STEP/RELAXATION - SHEAR MODULUS = 2.1E+11 N/M<sup>2</sup>

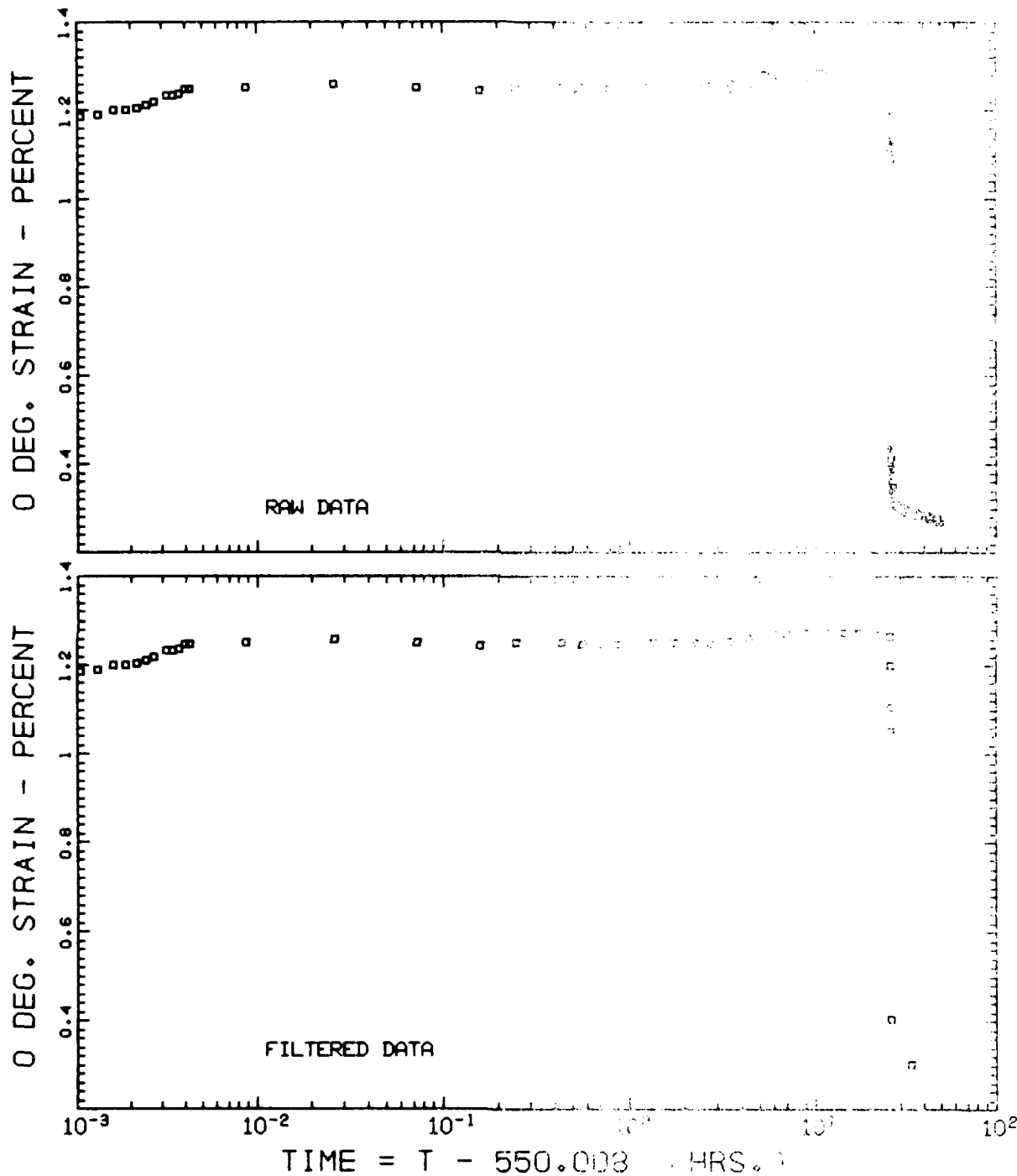

T300/5208 - STEP/RELAXATION - SPECIMEN No. 8 - STEP No. 12

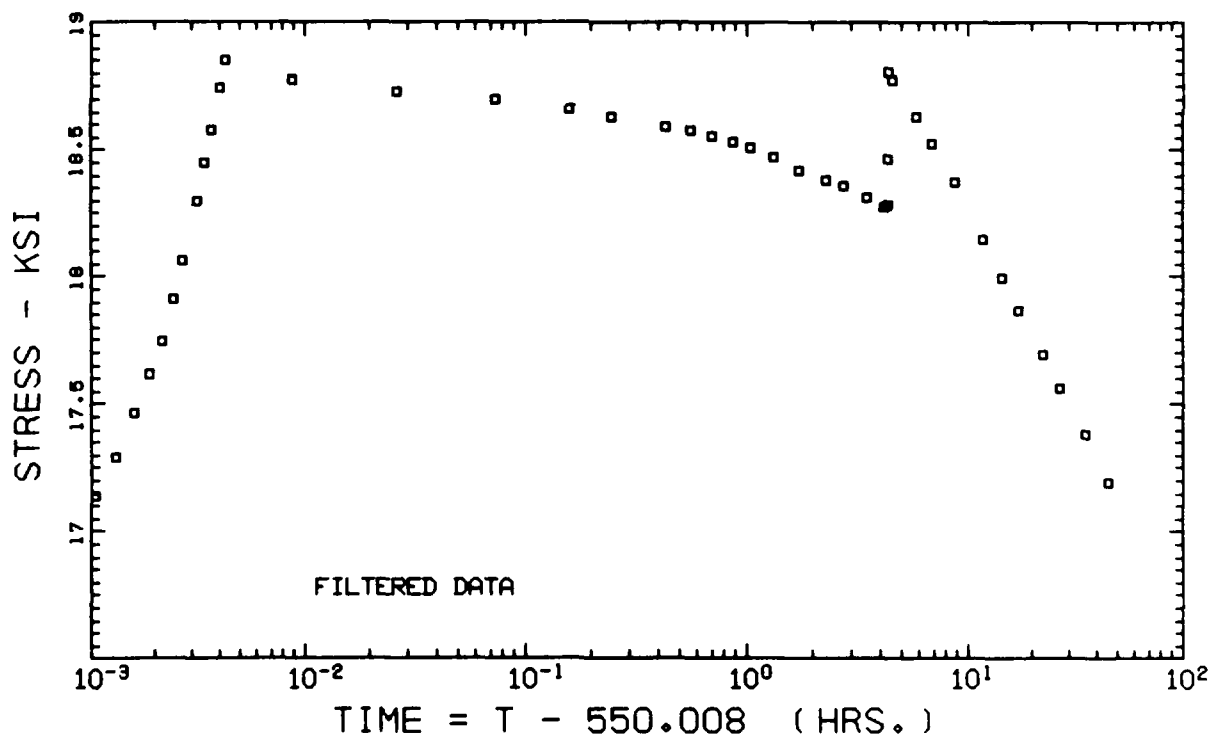
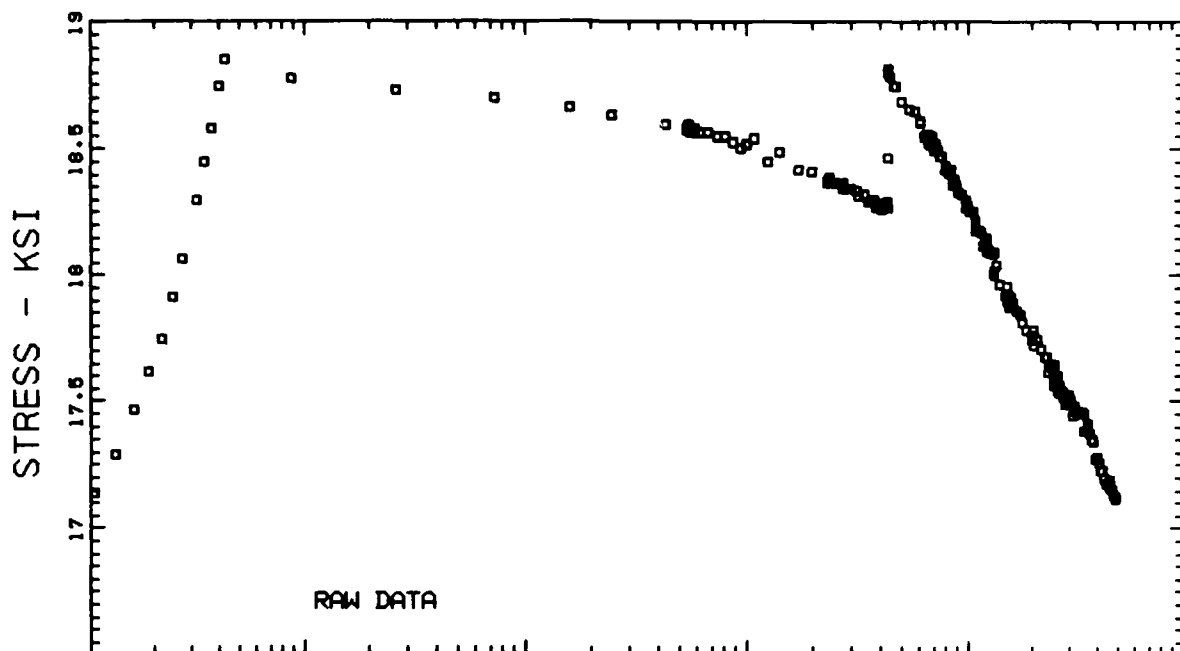

TIME = T - 550.008 (HRS.)

T300/5208 - STEP/RELAXATION - SPECIMEN No. 8 - STEP No. 12

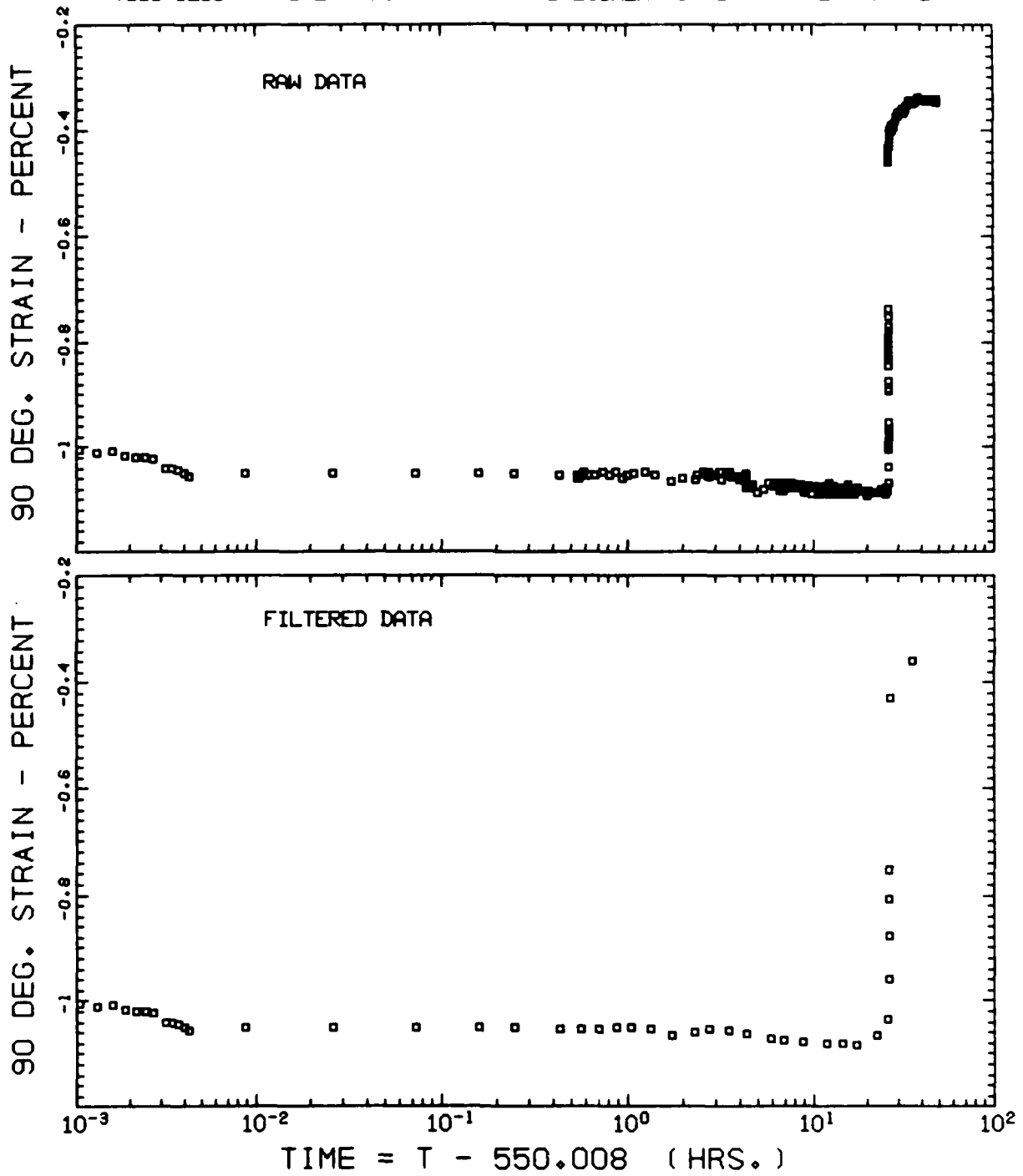

T300/5208 - STEP/RELAXATION - SPECIMEN No. 8 - STEP No. 12

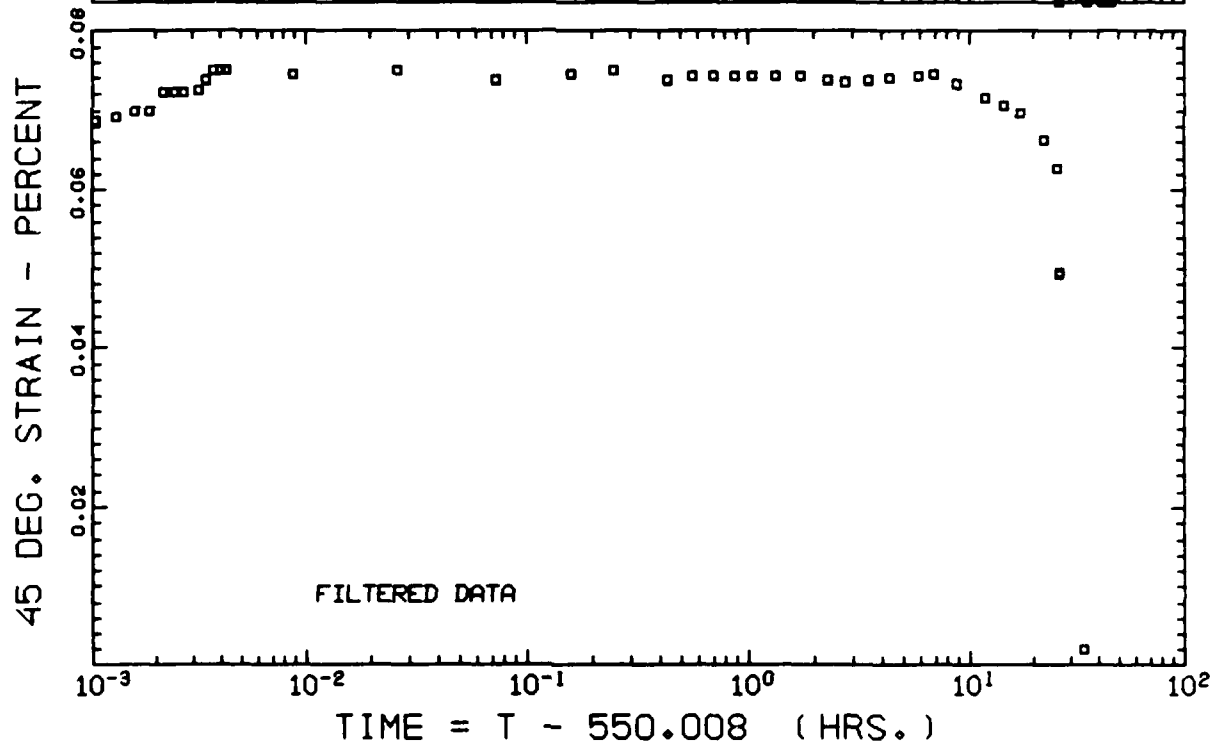
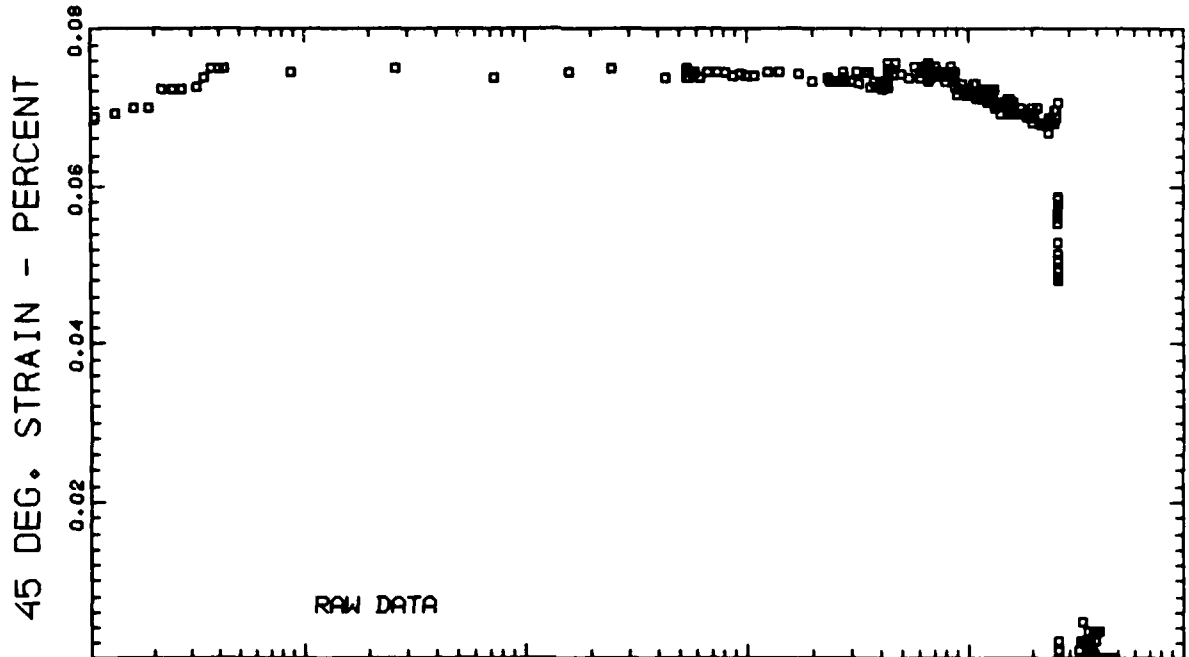

APPENDIX II

Numerical Compilation of Stress Strain History of  
Extensional Step-Relaxation Tests -  
T300/5208 [ $\pm 45$ ]<sub>S</sub> Graphite-Epoxy

Specimen No. 1 - Step No. 1 - Initial Time = 0 Hours

STEP RESPONSE			RELAXATION		
	TIME (Hrs)	Ø STRAIN (Micro)		TIME (Hrs)	Ø STRAIN (Micro)
1	0.0011	144.	23	0.0171	953.
2	0.0020	175.	24	0.0418	937.
3	0.0025	205.	25	0.5737	926.
4	0.0031	221.	26	1.8783	930.
5	0.0039	268.	27	2.1384	925.
6	0.0045	284.	28	6.1740	915.
7	0.0055	331.	29	7.0990	914.
8	0.0061	362.	30	9.0644	913.
9	0.0069	425.	31	11.0122	912.
10	0.0077	445.	32	14.8205	910.
11	0.0083	488.	33	18.6316	910.
12	0.0089	520.	34	21.1926	913.
13	0.0097	572.	35	30.7757	914.
14	0.0102	603.	36	34.8063	915.
15	0.0108	635.	37	41.4571	905.
16	0.0114	709.			
17	0.0121	772.			
18	0.0126	803.			
19	0.0132	851.			
20	0.0135	882.			
21	0.0137	914.			
22	0.0143	968.			

Specimen No. 1 - Step No. 1 - Initial Time = 0 Hours

STEP RESPONSE			RELAXATION		
	TIME (Hrs)	STRESS (Ksi)		TIME (Hrs)	STRESS (Ksi)
1	0.0011	0.100	23	0.0171	2.178
2	0.0020	0.160	24	0.0418	2.097
3	0.0025	0.240	25	0.5737	2.043
4	0.0031	0.319	26	1.8783	2.017
5	0.0039	0.399	27	2.1384	2.024
6	0.0045	0.479	28	6.1740	1.979
7	0.0055	0.639	29	7.0990	1.977
8	0.0061	0.718	30	9.0644	1.973
9	0.0069	0.818	31	11.0122	1.970
10	0.0077	0.938	32	14.8205	1.969
11	0.0083	1.018	33	18.6316	1.975
12	0.0089	1.098	34	21.1926	1.980
13	0.0097	1.218	35	30.7757	1.985
14	0.0102	1.319	36	34.8063	1.984
15	0.0108	1.437	37	41.4571	1.967
16	0.0114	1.558			
17	0.0121	1.697			
18	0.0126	1.835			
19	0.0132	1.956			
20	0.0135	2.036			
21	0.0137	2.116			
22	0.0143	2.257			



Specimen No. 1 - Step No. 1 - Initial Time = 0 Hours

STEP RESPONSE

RELAXATION

STEP RESPONSE			RELAXATION		
	TIME (Hrs)	90 STRAIN (Micro)		TIME (Hrs)	90 STRAIN (Micro)
1	0.0011	-43.	23	0.0171	-590.
2	0.0020	-58.	24	0.0418	-594.
3	0.0025	-58.	25	0.5737	-570.
4	0.0031	-58.	26	1.8783	-577.
5	0.0039	-87.	27	2.1384	-567.
6	0.0045	-115.	28	6.1740	-570.
7	0.0055	-145.	29	7.0990	-564.
8	0.0061	-158.	30	9.0644	-560.
9	0.0069	-201.	31	11.0122	-557.
10	0.0077	-246.	32	14.8205	-558.
11	0.0083	-259.	33	18.6310	-563.
12	0.0089	-290.	34	21.1926	-568.
13	0.0097	-333.	35	30.7757	-585.
14	0.0102	-377.	36	34.7654	-590.
15	0.0108	-377.	37	41.4571	-589.
16	0.0114	-417.			
17	0.0121	-435.			
18	0.0126	-478.			
19	0.0132	-518.			
20	0.0135	-532.			
21	0.0137	-561.			
22	0.0143	-604.			

Specimen No. 1 - Step No. 2 - Initial Time = 46.272 Hours

STEP RESPONSE			RELAXATION		
	TIME (Hrs)	Ø STRAIN (Micro)		TIME (Hrs)	Ø STRAIN (Micro)
1	0.0010	1040.	15	0.0669	1937.
2	0.0017	1118.	16	0.2459	1945.
3	0.0022	1197.	17	0.3255	1953.
4	0.0028	1260.	18	0.4299	1937.
5	0.0033	1323.	19	0.7043	1940.
6	0.0039	1397.	20	0.8828	1933.
7	0.0045	1496.	21	1.1651	1932.
8	0.0053	1572.	22	1.4160	1930.
9	0.0058	1625.	23	1.7334	1933.
10	0.0064	1717.	24	2.2440	1937.
11	0.0070	1780.	25	5.7992	1912.
12	0.0074	1828.	26	6.5824	1918.
13	0.0080	1891.	27	8.3769	1917.
14	0.0085	1969.	28	27.2773	1938.
			29	35.2958	1929.
			30	41.8174	1924.

Specimen No. 1 - Step No. 2 - Initial Time = 46.272 Hours

STEP RESPONSE			RELAXATION		
	TIME (Hrs)	STRESS (Ksi)		TIME (Hrs)	STRESS (Ksi)
1	0.0010	2.255	15	0.0669	4.571
2	0.0017	2.515	16	0.2459	4.531
3	0.0022	2.735	17	0.3255	4.509
4	0.0028	2.894	18	0.4299	4.493
5	0.0033	3.075	19	0.7043	4.481
6	0.0039	3.253	20	0.8828	4.477
7	0.0045	3.453	21	1.1651	4.468
8	0.0053	3.734	22	1.4160	4.457
9	0.0058	3.892	23	1.7334	4.445
10	0.0064	4.070	24	2.2440	4.431
11	0.0070	4.251	25	5.7992	4.385
12	0.0074	4.389	26	6.5824	4.371
13	0.0080	4.573	27	8.3769	4.351
14	0.0085	4.728	28	27.2773	4.244
			29	35.2958	4.226
			30	41.8174	4.203

Specimen No. 1 - Step No. 2 - Initial Time = 46.272 Hours

STEP RESPONSE			RELAXATION		
	TIME (Hrs)	90 STRAIN (Micro)		TIME (Hrs)	90 STRAIN (Micro)
1	0.0010	-642.	15	0.0669	-1319.
2	0.0017	-705.	16	0.2459	-1299.
3	0.0022	-777.	17	0.3255	-1309.
4	0.0028	-820.	18	0.4299	-1334.
5	0.0033	-877.	19	0.7043	-1310.
6	0.0039	-935.	20	0.8828	-1295.
7	0.0045	-978.	21	1.1651	-1288.
8	0.0053	-1035.	22	1.4160	-1298.
9	0.0058	-1093.	23	1.7334	-1297.
10	0.0064	-1136.	24	2.2440	-1284.
11	0.0070	-1179.	25	5.7992	-1296.
12	0.0074	-1232.	26	6.5824	-1285.
13	0.0080	-1280.	27	8.3769	-1273.
14	0.0085	-1323.	28	27.2773	-1285.
			29	35.2958	-1265.
			30	41.8174	-1248.

Specimen No. 1 - Step No. 3 - Initial Time = 88.559 Hours

STEP RESPONSE			RELAXATION		
	TIME (Hrs)	Ø STRAIN (Micro)		TIME (Hrs)	Ø STRAIN (Micro)
1	0.0004	1969.	17	0.0137	3173.
2	0.0010	2064.	18	0.4560	3152.
3	0.0012	2111.	19	0.5972	3134.
4	0.0018	2205.	20	0.6718	3176.
5	0.0023	2282.	21	1.3965	3149.
6	0.0029	2378.	22	1.8726	3147.
7	0.0035	2457.	23	2.2135	3146.
8	0.0040	2532.	24	2.6036	3145.
9	0.0046	2626.	25	3.6454	3149.
10	0.0051	2704.	26	4.8639	3147.
11	0.0056	2797.	27	5.8379	3149.
12	0.0062	2876.	28	6.8367	3154.
13	0.0067	2977.	29	8.8938	3165.
14	0.0073	3071.	30	11.2294	3165.
15	0.0078	3126.	31	15.2110	3159.
16	0.0084	3260.	32	17.8373	3154.
			33	21.9113	3151.
			34	28.3108	3158.
			35	36.1319	3162.
			36	44.8627	3160.

Specimen No. 1 - Step No. 3 - Initial Time = 88.559 Hours

STEP RESPONSE			RELAXATION		
	TIME (Hrs)	STRESS (Ksi)		TIME (Hrs)	STRESS (Ksi)
1	0.0004	4.311	17	0.0137	7.361
2	0.0010	4.591	18	0.4560	7.043
3	0.0012	4.711	19	0.5972	7.049
4	0.0018	4.930	20	0.6718	7.024
5	0.0023	5.190	21	1.3965	6.983
6	0.0029	5.406	22	1.8726	6.959
7	0.0035	5.629	23	2.2135	6.944
8	0.0040	5.865	24	2.6036	6.927
9	0.0046	6.068	25	3.6454	6.897
10	0.0051	6.264	26	4.8639	6.870
11	0.0056	6.484	27	5.8379	6.857
12	0.0062	6.687	28	6.8367	6.848
13	0.0067	6.903	29	8.8938	6.833
14	0.0073	7.126	30	11.2294	6.811
15	0.0078	7.305	31	15.2110	6.769
16	0.0084	7.501	32	17.8373	6.739
			33	21.9113	6.713
			34	28.3108	6.697
			35	36.1319	6.681
			36	44.8627	6.649

Specimen No. 1 - Step No. 3 - Initial Time = 88.559 Hours

STEP RESPONSE			RELAXATION		
	TIME (Hrs)	90 STRAIN (Micro)		TIME (Hrs)	90 STRAIN (Micro)
1	0.0004	-1309.	17	0.0137	-2169.
2	0.0010	-1381.	18	0.4560	-2167.
3	0.0012	-1384.	19	0.5972	-2186.
4	0.0018	-1441.	20	0.6718	-2157.
5	0.0023	-1539.	21	1.3965	-2160.
6	0.0029	-1596.	22	1.8726	-2155.
7	0.0035	-1682.	23	2.2135	-2154.
8	0.0040	-1711.	24	2.6036	-2154.
9	0.0046	-1783.	25	3.6454	-2161.
10	0.0051	-1826.	26	4.8639	-2158.
11	0.0056	-1854.	27	5.8379	-2155.
12	0.0062	-1941.	28	6.8367	-2155.
13	0.0067	-2013.	29	8.8938	-2155.
14	0.0073	-2071.	30	11.2294	-2154.
15	0.0078	-2128.	31	15.2110	-2150.
16	0.0084	-2183.	32	17.8373	-2154.
			33	21.9113	-2157.
			34	28.3108	-2158.
			35	36.1319	-2158.
			36	44.8627	-2160.

Specimen No. 1 - Step No. 4 - Initial Time = 135.787 Hours

STEP RESPONSE			RELAXATION			
	TIME (Hrs)	Ø STRAIN (Micro)		TIME (Hrs)	Ø STRAIN (Micro)	
	1	0.0008	3235.	17	0.1515	4521.
	2	0.0013	3329.	18	11.8435	4511.
	3	0.0016	3418.	19	13.5828	4510.
	4	0.0022	3485.	20	17.0824	4510.
	5	0.0027	3579.	21	29.4640	4501.
	6	0.0033	3644.	22	35.4628	4507.
	7	0.0038	3751.	23	46.5730	4506.
	8	0.0044	3845.			
	9	0.0049	3908.			
	10	0.0055	3985.			
	11	0.0060	4047.			
	12	0.0065	4125.			
	13	0.0071	4251.			
	14	0.0074	4313.			
	15	0.0079	4426.			
	16	0.0085	4435.			

Specimen No. 1 - Step No. 4 - Initial Time = 135.787 Hours

STEP RESPONSE			RELAXATION			
	TIME (Hrs)	STRESS (Ksi)		TIME (Hrs)	STRESS (Ksi)	
	1	0.0008	6.866	17	0.1515	9.561
	2	0.0013	7.106	18	11.8435	9.013
	3	0.0016	7.225	19	13.5828	8.982
	4	0.0022	7.485	20	17.0824	8.922
	5	0.0027	7.724	21	29.4640	8.790
	6	0.0033	7.960	22	35.4628	8.764
	7	0.0038	8.204	23	46.5730	8.702
	8	0.0044	8.379			
	9	0.0049	8.598			
	10	0.0055	8.798			
	11	0.0060	8.957			
	12	0.0065	9.157			
	13	0.0071	9.376			
	14	0.0074	9.476			
	15	0.0079	9.681			
	16	0.0085	9.875			

Specimen No. 1 - Step No. 4 - Initial Time = 135.787 Hours

STEP RESPONSE			RELAXATION		
	TIME (Hrs)	90 STRAIN (Micro)		TIME (Hrs)	90 STRAIN (Micro)
1	0.0008	-2229.	17	0.1515	-3204.
2	0.0013	-2305.	18	11.8435	-3164.
3	0.0016	-2325.	19	13.5828	-3176.
4	0.0022	-2402.	20	17.0824	-3194.
5	0.0027	-2440.	21	29.4640	-3182.
6	0.0033	-2511.	22	35.4628	-3178.
7	0.0038	-2562.	23	46.5730	-3171.
8	0.0044	-2639.			
9	0.0049	-2675.			
10	0.0055	-2739.			
11	0.0060	-2796.			
12	0.0065	-2868.			
13	0.0071	-2948.			
14	0.0074	-2991.			
15	0.0079	-3049.			
16	0.0085	-3096.			

Specimen No. 1 - Step No. 5 - Initial Time = 183.798 Hours

STEP RESPONSE			RELAXATION		
	TIME (Hrs)	Ø STRAIN (Micro)		TIME (Hrs)	Ø STRAIN (Micro)
1	0.0008	4610.	17	0.0306	5893.
2	0.0014	4704.	18	0.3075	5915.
3	0.0016	4767.	19	0.7117	5935.
4	0.0022	4860.	20	0.8897	5927.
5	0.0028	4993.	21	1.1480	5930.
6	0.0033	5088.	22	1.3635	5929.
7	0.0038	5110.	23	1.9329	5940.
8	0.0041	5173.	24	2.2373	5939.
9	0.0046	5251.	25	2.8244	5936.
10	0.0052	5329.	26	3.5785	5932.
11	0.0057	5481.	27	4.3996	5930.
12	0.0063	5576.	28	5.6764	5933.
13	0.0069	5583.	29	7.2112	5935.
14	0.0074	5660.	30	8.6007	5934.
15	0.0080	5782.	31	11.1995	5938.
16	0.0085	5876.	32	14.7932	5940.
			33	17.5067	5937.
			34	21.9163	5936.
			35	27.5385	5940.
			36	34.2924	5959.
			37	46.1974	5951.
			38	50.2135	5943.

Specimen No. 1 - Step No. 5 - Initial Time = 183.798 Hours

STEP RESPONSE			RELAXATION		
	TIME (Hrs)	STRESS (Ksi)		TIME (Hrs)	STRESS (Ksi)
1	0.0008	8.987	17	0.0306	11.830
2	0.0014	9.266	18	0.3075	11.527
3	0.0016	9.361	19	0.7117	11.401
4	0.0022	9.601	20	0.8897	11.367
5	0.0028	9.820	21	1.1480	11.320
6	0.0033	10.065	22	1.3635	11.293
7	0.0038	10.259	23	1.9329	11.236
8	0.0041	10.354	24	2.2373	11.211
9	0.0046	10.533	25	2.8244	11.170
10	0.0052	10.778	26	3.5785	11.128
11	0.0057	10.984	27	4.3996	11.087
12	0.0063	11.178	28	5.6764	11.034
13	0.0069	11.391	29	7.2112	10.978
14	0.0074	11.571	30	8.6007	10.940
15	0.0080	11.770	31	11.1995	10.879
16	0.0085	11.970	32	14.7932	10.806
			33	17.5067	10.760
			34	21.9163	10.701
			35	27.5385	10.664
			36	34.2924	10.614
			37	46.1974	10.528
			38	50.2135	10.504



Specimen No. 1 - Step No. 5 - Initial Time = 183.798 Hours

STEP RESPONSE			RELAXATION		
	TIME (Hrs)	90 STRAIN (Micro)		TIME (Hrs)	90 STRAIN (Micro)
1	0.0008	-3253.	17	0.0306	-4180.
2	0.0014	-3338.	18	0.3075	-4202.
3	0.0016	-3381.	19	0.7117	-4235.
4	0.0022	-3397.	20	0.8897	-4232.
5	0.0028	-3495.	21	1.1480	-4238.
6	0.0033	-3581.	22	1.3635	-4238.
7	0.0038	-3609.	23	1.9329	-4242.
8	0.0041	-3638.	24	2.2373	-4240.
9	0.0046	-3709.	25	2.8244	-4249.
10	0.0052	-3766.	26	3.5785	-4255.
11	0.0057	-3823.	27	4.3996	-4259.
12	0.0063	-3895.	28	5.6764	-4257.
13	0.0069	-3938.	29	7.2112	-4255.
14	0.0074	-3995.	30	8.6007	-4256.
15	0.0080	-4066.	31	11.1995	-4258.
16	0.0085	-4137.	32	14.7932	-4257.
			33	17.5067	-4257.
			34	21.9163	-4275.
			35	27.5385	-4292.
			36	34.2924	-4313.
			37	46.1974	-4307.
			38	50.2135	-4310.

Specimen No. 1 - Step No. 6 - Initial Time = 235.859 Hours

STEP RESPONSE			RELAXATION		
	TIME (Hrs)	Ø STRAIN (Micro)		TIME (Hrs)	Ø STRAIN (Micro)
1	0.0006	6111.	21	0.0119	7443.
2	0.0008	6095.	22	0.0538	7486.
3	0.0013	6204.	23	0.2488	7490.
4	0.0016	6267.	24	0.7102	7474.
5	0.0021	6327.	25	2.2325	7522.
6	0.0027	6420.	26	4.9959	7564.
7	0.0032	6548.	27	5.7633	7536.
8	0.0035	6611.	28	7.2866	7538.
9	0.0041	6637.	29	8.8658	7541.
10	0.0046	6730.	30	15.0647	7574.
11	0.0049	6792.	31	22.5499	7567.
12	0.0052	6892.	32	27.2436	7576.
13	0.0058	6932.	33	38.4920	7586.
14	0.0063	7095.	34	42.4738	7587.
15	0.0066	7102.			
16	0.0072	7195.			
17	0.0074	7226.			
18	0.0077	7288.			
19	0.0083	7439.			
20	0.0085	7443.			

Specimen No. 1 - Step No. 6 - Initial Time = 235.859 Hours

STEP RESPONSE			RELAXATION		
	TIME (Hrs)	STRESS (Ksi)		TIME (Hrs)	STRESS (Ksi)
1	0.0006	10.713	21	0.0119	13.965
2	0.0008	10.864	22	0.0538	13.732
3	0.0013	11.118	23	0.2488	13.513
4	0.0016	11.257	24	0.7102	13.333
5	0.0021	11.497	25	2.2325	13.061
6	0.0027	11.730	26	4.9959	12.834
7	0.0032	11.956	27	5.7633	12.823
8	0.0035	12.076	28	7.2866	12.767
9	0.0041	12.275	29	8.8658	12.708
10	0.0046	12.508	30	15.0647	12.572
11	0.0049	12.628	31	22.5499	12.428
12	0.0052	12.754	32	27.2436	12.364
13	0.0058	13.014	33	38.4920	12.223
14	0.0063	13.220	34	42.4738	12.176
15	0.0066	13.346			
16	0.0072	13.540			
17	0.0074	13.666			
18	0.0077	13.765			
19	0.0083	13.972			
20	0.0085	14.072			

Specimen No. 1 - Step No. 6 - Initial Time = 235.859 Hours

STEP RESPONSE

RELAXATION

STEP RESPONSE			RELAXATION		
	TIME (Hrs)	90 STRAIN (Micro)		TIME (Hrs)	90 STRAIN (Micro)
1	0.0006	-4380.	21	0.0119	-5308.
2	0.0008	-4437.	22	0.0538	-5450.
3	0.0013	-4480.	23	0.2488	-5337.
4	0.0016	-4487.	24	0.7102	-5478.
5	0.0021	-4594.	25	2.2325	-5480.
6	0.0027	-4614.	26	4.9959	-5608.
7	0.0032	-4685.	27	5.7633	-5509.
8	0.0035	-4751.	28	7.2866	-5515.
9	0.0041	-4822.	29	8.8658	-5526.
10	0.0046	-4893.	30	15.0647	-5578.
11	0.0049	-4922.	31	22.5499	-5601.
12	0.0052	-4912.	32	27.2436	-5605.
13	0.0058	-5036.	33	38.4920	-5618.
14	0.0063	-5107.	34	42.4738	-5623.
15	0.0066	-5081.			
16	0.0072	-5207.			
17	0.0074	-5180.			
18	0.0077	-5223.			
19	0.0083	-5280.			
20	0.0085	-5350.			

Specimen No. 1 - Step No. 7 - Initial Time = 280.524 Hours

STEP RESPONSE			RELAXATION			
	TIME (Hrs)	Ø STRAIN (Micro)		TIME (Hrs)	Ø STRAIN (Micro)	
	1	0.0004	7629.	22	0.0131	9158.
	2	0.0009	7783.	23	0.1345	9189.
	3	0.0012	7785.	24	0.2959	9079.
	4	0.0015	7923.	25	0.4626	9169.
	5	0.0018	8017.	26	0.6101	9159.
	6	0.0020	8017.	27	0.7370	9164.
	7	0.0023	8017.	28	0.9403	9162.
	8	0.0026	8079.	29	1.0802	9176.
	9	0.0032	8157.	30	1.4169	9185.
	10	0.0037	8265.	31	1.6406	9194.
	11	0.0043	8343.	32	2.3408	9207.
	12	0.0049	8533.	33	2.7452	9208.
	13	0.0054	8611.	34	3.4976	9216.
	14	0.0057	8622.	35	4.4360	9237.
	15	0.0060	8684.	36	5.1069	9241.
	16	0.0065	8746.	37	7.5565	9243.
	17	0.0068	8792.	38	8.9685	9239.
	18	0.0071	8854.	39	11.6885	9242.
	19	0.0076	8932.	40	14.6363	9241.
	20	0.0079	9010.	41	17.2653	9245.
	21	0.0085	9087.	42	23.3340	9260.
				43	27.0474	9265.
				44	38.0539	9267.
				45	43.8521	9268.

Specimen No. 1 - Step No. 7 - Initial Time = 280.524 Hours

STEP RESPONSE			RELAXATION			
	TIME (Hrs)	STRESS (Ksi)		TIME (Hrs)	STRESS (Ksi)	
	1	0.0004	12.335	22	0.0131	15.669
	2	0.0009	12.641	23	0.1345	15.257
	3	0.0012	12.768	24	0.2959	15.122
	4	0.0015	12.894	25	0.4626	15.000
	5	0.0018	13.034	26	0.6101	14.935
	6	0.0020	13.167	27	0.7370	14.885
	7	0.0023	13.293	28	0.9403	14.807
	8	0.0026	13.433	29	1.0802	14.762
	9	0.0032	13.653	30	1.4169	14.672
	10	0.0037	13.885	31	1.6406	14.627
	11	0.0043	14.124	32	2.3408	14.517
	12	0.0049	14.391	33	2.7452	14.461
	13	0.0054	14.611	34	3.4976	14.383
	14	0.0057	14.710	35	4.4360	14.298
	15	0.0060	14.843	36	5.1069	14.258
	16	0.0065	15.050	37	7.5565	14.139
	17	0.0068	15.162	38	8.9685	14.076
	18	0.0071	15.289	39	11.6885	13.966
	19	0.0076	15.517	40	14.6363	13.858
	20	0.0079	15.581	41	17.2653	13.791
	21	0.0085	15.780	42	23.3340	13.673
				43	27.0474	13.619
				44	38.0539	13.494
				45	43.8521	13.430

Specimen No. 1 - Step No. 7 - Initial Time = 280.524 Hours

STEP RESPONSE			RELAXATION		
	TIME (Hrs)	90 STRAIN (Micro)		TIME (Hrs)	90 STRAIN (Micro)
1	0.0004	-5664.	22	0.0131	-6705.
2	0.0009	-5795.	23	0.1345	-6816.
3	0.0012	-5839.	24	0.2959	-6695.
4	0.0015	-5821.	25	0.4626	-6784.
5	0.0018	-5878.	26	0.6101	-6764.
6	0.0020	-5906.	27	0.7370	-6766.
7	0.0023	-5888.	28	0.9403	-6807.
8	0.0026	-5978.	29	1.0802	-6813.
9	0.0032	-6021.	30	1.4169	-6828.
10	0.0037	-6044.	31	1.6406	-6834.
11	0.0043	-6163.	32	2.3408	-6868.
12	0.0049	-6235.	33	2.7452	-6879.
13	0.0054	-6320.	34	3.4976	-6898.
14	0.0057	-6334.	35	4.4360	-6909.
15	0.0060	-6391.	36	5.1069	-6915.
16	0.0065	-6449.	37	7.5565	-6927.
17	0.0068	-6477.	38	8.9685	-6923.
18	0.0071	-6520.	39	11.6885	-6929.
19	0.0076	-6525.	40	14.6363	-6938.
20	0.0079	-6568.	41	17.2653	-6950.
21	0.0085	-6677.	42	23.3340	-6981.
			43	27.0474	-6995.
			44	38.0539	-7016.
			45	43.8521	-7027.

Specimen No. 1 - Step No. 8 - Initial Time = 327.828 Hours

STEP RESPONSE			RELAXATION		
	TIME (Hrs)	Ø STRAIN (Micro)		TIME (Hrs)	Ø STRAIN (Micro)
1	0.0006	9361.	21	0.0712	10900.
2	0.0009	9351.	22	0.3040	10685.
3	0.0015	9475.	23	0.3800	10721.
4	0.0020	9494.	24	0.4233	10732.
5	0.0023	9630.	25	0.5649	10723.
6	0.0026	9692.	26	0.6998	10736.
7	0.0032	9785.	27	1.1456	10780.
8	0.0034	9771.	28	2.3161	10823.
9	0.0040	9940.	29	2.6628	10789.
10	0.0043	9986.	30	3.5945	10787.
11	0.0045	10049.	31	4.3243	10817.
12	0.0048	10017.	32	7.1779	10845.
13	0.0054	10188.	33	9.0141	10824.
14	0.0057	10250.	34	11.8883	10861.
15	0.0062	10328.	35	12.8856	10863.
16	0.0068	10341.	36	18.2744	10869.
17	0.0070	10483.	37	23.8734	10836.
18	0.0076	10576.	38	28.0469	10839.
19	0.0082	10669.	39	37.0553	10848.
20	0.0084	10715.	40	41.4390	10853.
			41	56.2681	10857.
			42	72.0370	10857.

Specimen No. 1 - Step No. 8 - Initial Time = 327.828 Hours

STEP RESPONSE			RELAXATION		
	TIME (Hrs)	STRESS (Ksi)		TIME (Hrs)	STRESS (Ksi)
1	0.0006	13.586	21	0.0712	16.655
2	0.0009	13.745	22	0.3040	16.416
3	0.0015	14.032	23	0.3800	16.351
4	0.0020	14.331	24	0.4293	16.319
5	0.0023	14.451	25	0.5649	16.248
6	0.0026	14.583	26	0.6998	16.183
7	0.0032	14.850	27	1.1456	16.026
8	0.0034	14.982	28	2.3161	15.773
9	0.0040	15.257	29	2.6628	15.723
10	0.0043	15.361	30	3.5945	15.609
11	0.0045	15.461	31	4.3243	15.533
12	0.0048	15.561	32	7.1779	15.325
13	0.0054	15.800	33	9.0141	15.228
14	0.0057	15.920	34	11.8883	15.103
15	0.0062	16.119	35	12.8856	15.076
16	0.0068	16.367	36	18.2744	14.949
17	0.0070	16.458	37	23.8734	14.840
18	0.0076	16.678	38	28.0469	14.779
19	0.0082	16.926	39	37.0553	14.657
20	0.0084	17.026	40	41.4390	14.611
			41	56.2681	14.494
			42	72.0370	14.391

Specimen No. 1 - Step No. 8 - Initial Time = 327.828 Hours

STEP RESPONSE			RELAXATION		
	TIME (Hrs)	90 STRAIN (Micro)		TIME (Hrs)	90 STRAIN (Micro)
1	0.0006	-7104.	21	0.0712	-8061.
2	0.0009	-7090.	22	0.3040	-8051.
3	0.0015	-7176.	23	0.3800	-8073.
4	0.0020	-7247.	24	0.4293	-8078.
5	0.0023	-7276.	25	0.5649	-8078.
6	0.0026	-7247.	26	0.6998	-8107.
7	0.0032	-7332.	27	1.1456	-8116.
8	0.0034	-7478.	28	2.3161	-8247.
9	0.0040	-7504.	29	2.6628	-8202.
10	0.0043	-7504.	30	3.5945	-8174.
11	0.0045	-7502.	31	4.3243	-8186.
12	0.0048	-7604.	32	7.1779	-8228.
13	0.0054	-7647.	33	9.0141	-8242.
14	0.0057	-7615.	34	11.8850	-8282.
15	0.0062	-7700.	35	12.8856	-8281.
16	0.0068	-7804.	36	18.2744	-8295.
17	0.0070	-7847.	37	23.8734	-8307.
18	0.0076	-7918.	38	28.0469	-8317.
19	0.0082	-7975.	39	37.0553	-8326.
20	0.0084	-8018.	40	41.4390	-8336.
			41	56.2681	-8355.
			42	72.0370	-8372.

Specimen No. 1 - Step No. 9 - Initial Time = 406.564 Hours

STEP RESPONSE			RELAXATION		
	TIME (Hrs)	Ø STRAIN (Micro)		TIME (Hrs)	Ø STRAIN (Micro)
1	0.0003	10879.	23	0.0305	12341.
2	0.0006	11010.	24	0.1036	12518.
3	0.0011	11221.	25	0.2364	12387.
4	0.0014	11196.	26	0.5869	12431.
5	0.0017	11243.	27	0.6964	12426.
6	0.0020	11202.	28	0.8575	12468.
7	0.0023	11279.	29	1.1337	12429.
8	0.0028	11460.	30	1.4318	12421.
9	0.0031	11537.	31	1.7616	12432.
10	0.0036	11541.	32	2.4506	12468.
11	0.0039	11602.	33	2.6094	12428.
12	0.0042	11664.	34	7.0632	12469.
13	0.0048	11741.	35	8.8688	12514.
14	0.0050	11802.	36	11.7124	12506.
15	0.0056	11971.	37	15.4065	12537.
16	0.0061	12143.	38	16.0851	12519.
17	0.0064	12111.	39	22.7921	12518.
18	0.0070	12188.	40	26.1502	12512.
19	0.0073	12266.	41	39.9051	12594.
20	0.0078	12264.			
21	0.0081	12310.			
22	0.0084	12356.			

Specimen No. 1 - Step No. 9 - Initial Time = 406.564 Hours

STEP RESPONSE			RELAXATION		
	TIME (Hrs)	STRESS (Ksi)		TIME (Hrs)	STRESS (Ksi)
1	0.0003	14.543	23	0.0305	17.935
2	0.0006	14.710	24	0.1036	17.753
3	0.0011	15.002	25	0.2364	17.627
4	0.0014	15.170	26	0.5869	17.415
5	0.0017	15.289	27	0.6964	17.376
6	0.0020	15.441	28	0.8575	17.325
7	0.0023	15.561	29	1.1337	17.238
8	0.0028	15.840	30	1.4318	17.154
9	0.0031	15.991	31	1.7616	17.073
10	0.0036	16.267	32	2.4506	16.923
11	0.0039	16.399	33	2.6094	16.920
12	0.0042	16.518	34	7.0632	16.447
13	0.0048	16.758	35	8.8688	16.343
14	0.0050	16.866	36	11.7124	16.213
15	0.0056	17.086	37	15.4065	16.064
16	0.0061	17.285	38	16.0851	16.042
17	0.0064	17.396	39	22.7921	15.900
18	0.0070	17.645	40	26.1502	15.862
19	0.0073	17.764	41	39.9051	15.603
20	0.0078	17.975			
21	0.0081	18.094			
22	0.0084	18.194			



Specimen No. 1 - Step No. 9 - Initial Time = 406.564 Hours

STEP RESPONSE			RELAXATION		
	TIME (Hrs)	90 STRAIN (Micro)		TIME (Hrs)	90 STRAIN (Micro)
1	0.0003	-8446.	23	0.0305	-9325.
2	0.0006	-8503.	24	0.1036	-9592.
3	0.0011	-8588.	25	0.2364	-9441.
4	0.0014	-8549.	26	0.5869	-9538.
5	0.0017	-8674.	27	0.6964	-9537.
6	0.0020	-8620.	28	0.8575	-9573.
7	0.0023	-8662.	29	1.1337	-9537.
8	0.0028	-8747.	30	1.4318	-9532.
9	0.0031	-8761.	31	1.7616	-9588.
10	0.0036	-8917.	32	2.4506	-9800.
11	0.0039	-8875.	33	2.6094	-9632.
12	0.0042	-8903.	34	7.0632	-9664.
13	0.0048	-9045.	35	8.8688	-9682.
14	0.0050	-9088.	36	11.7124	-9690.
15	0.0056	-9073.	37	15.4065	-9749.
16	0.0061	-9144.	38	16.0851	-9732.
17	0.0064	-9245.	39	22.7921	-9721.
18	0.0070	-9302.	40	26.1502	-9721.
19	0.0073	-9345.	41	39.9051	-9840.
20	0.0078	-9328.			
21	0.0081	-9430.			
22	0.0084	-9473.			

Specimen No. 2 - Step No. 5 - Initial Time = 183.798 Hours

STEP RESPONSE			RELAXATION		
	TIME (Hrs)	Ø STRAIN (Micro)		TIME (Hrs)	Ø STRAIN (Micro)
1	0.0008	244.	17	0.0306	485.
2	0.0014	244.	18	0.3075	473.
3	0.0016	244.	19	0.7117	466.
4	0.0022	261.	20	0.8897	471.
5	0.0028	277.	21	1.1480	472.
6	0.0033	296.	22	1.3635	478.
7	0.0038	310.	23	1.9329	471.
8	0.0041	310.	24	2.2373	474.
9	0.0046	326.	25	2.8244	474.
10	0.0052	358.	26	3.5785	474.
11	0.0057	375.	27	4.3996	473.
12	0.0063	358.	28	5.6764	472.
13	0.0069	388.	29	7.2112	474.
14	0.0074	420.	30	8.6007	475.
15	0.0080	456.	31	11.1995	475.
16	0.0085	489.	32	14.7932	473.
			33	17.5067	471.
			34	21.9163	464.
			35	27.5385	467.
			36	34.2924	466.
			37	46.1974	457.
			38	50.2135	454.

Specimen No. 2 - Step No. 5 - Initial Time = 183.798 Hours

STEP RESPONSE			RELAXATION		
	TIME (Hrs)	STRESS (Ksi)		TIME (Hrs)	STRESS (Ksi)
1	0.0008	0.304	17	0.0306	0.934
2	0.0014	0.283	18	0.3075	0.891
3	0.0016	0.304	19	0.7117	0.889
4	0.0022	0.348	20	0.8897	0.892
5	0.0028	0.369	21	1.1480	0.890
6	0.0033	0.413	22	1.3635	0.893
7	0.0038	0.478	23	1.9329	0.888
8	0.0041	0.478	24	2.2373	0.890
9	0.0046	0.543	25	2.8244	0.886
10	0.0052	0.608	26	3.5785	0.884
11	0.0057	0.608	27	4.3996	0.882
12	0.0063	0.652	28	5.6764	0.882
13	0.0069	0.717	29	7.2112	0.882
14	0.0074	0.782	30	8.6007	0.883
15	0.0080	0.891	31	11.1995	0.884
16	0.0085	0.977	32	14.7932	0.878
			33	17.5067	0.871
			34	21.9163	0.856
			35	27.5385	0.868
			36	34.2924	0.871
			37	46.1974	0.843
			38	50.2135	0.831

Specimen No. 2 - Step No. 5 - Initial Time = 183.798 Hours

STEP RESPONSE			RELAXATION		
	TIME (Hrs)	90 STRAIN (Micro)		TIME (Hrs)	90 STRAIN (Micro)
1	0.0008	-15.	17	0.0306	-139.
2	0.0014	-15.	18	0.3075	-146.
3	0.0016	-15.	19	0.7117	-146.
4	0.0022	-15.	20	0.8897	-141.
5	0.0028	-15.	21	1.1480	-140.
6	0.0033	-31.	22	1.3635	-137.
7	0.0038	-31.	23	1.9329	-138.
8	0.0041	-46.	24	2.2373	-136.
9	0.0046	-61.	25	2.8244	-139.
10	0.0052	-62.	26	3.5785	-140.
11	0.0057	-77.	27	4.3996	-141.
12	0.0063	-62.	28	5.6764	-138.
13	0.0069	-91.	29	7.2112	-135.
14	0.0074	-107.	30	8.6007	-133.
15	0.0080	-123.	31	11.1995	-132.
16	0.0085	-139.	32	14.7932	-129.
			33	17.5067	-126.
			34	21.9163	-124.
			35	27.5385	-130.
			36	34.2924	-138.
			37	46.1974	-132.
			38	50.2135	-130.

Specimen No. 2 - Step No. 6 - Initial Time = 235.859 Hours

STEP RESPONSE			RELAXATION		
	TIME (Hrs)	Ø STRAIN (Micro)		TIME (Hrs)	Ø STRAIN (Micro)
1	0.0006	509.	21	0.0119	1304.
2	0.0008	554.	22	0.0538	1271.
3	0.0013	603.	23	0.2488	1277.
4	0.0016	619.	24	0.7102	1271.
5	0.0021	695.	25	2.2325	1291.
6	0.0027	744.	26	4.9959	1281.
7	0.0032	776.	27	5.7633	1287.
8	0.0035	815.	28	7.2866	1287.
9	0.0041	870.	29	8.8658	1286.
10	0.0046	912.	30	15.0647	1277.
11	0.0049	945.	31	22.5499	1281.
12	0.0052	970.	32	27.2436	1289.
13	0.0058	1027.	33	38.4920	1298.
14	0.0063	1092.	34	42.4738	1299.
15	0.0066	1124.			
16	0.0072	1173.			
17	0.0074	1206.			
18	0.0077	1248.			
19	0.0083	1304.			
20	0.0085	1326.			

Specimen No. 2 - Step No. 6 - Initial Time = 235.859 Hours

STEP RESPONSE			RELAXATION		
	TIME (Hrs)	STRESS (Ksi)		TIME (Hrs)	STRESS (Ksi)
1	0.0006	1.000	21	0.0119	3.173
2	0.0008	1.087	22	0.0538	3.062
3	0.0013	1.260	23	0.2488	3.039
4	0.0016	1.347	24	0.7102	3.019
5	0.0021	1.499	25	2.2325	3.005
6	0.0027	1.650	26	4.9959	2.955
7	0.0032	1.781	27	5.7633	2.996
8	0.0035	1.847	28	7.2866	2.994
9	0.0041	1.999	29	8.8658	2.987
10	0.0046	2.150	30	15.0647	2.965
11	0.0049	2.195	31	22.5499	2.933
12	0.0052	2.281	32	27.2436	2.937
13	0.0058	2.456	33	38.4920	2.929
14	0.0063	2.628	34	42.4738	2.922
15	0.0066	2.693			
16	0.0072	2.825			
17	0.0074	2.910			
18	0.0077	3.018			
19	0.0083	3.169			
20	0.0085	3.235			

Specimen No. 2 - Step No. 6 - Initial Time = 235.859 Hours

STEP RESPONSE

RELAXATION

STEP RESPONSE			RELAXATION		
	TIME (Hrs)	90 STRAIN (Micro)		TIME (Hrs)	90 STRAIN (Micro)
1	0.0006	-186.	21	0.0119	-706.
2	0.0008	-201.	22	0.0538	-696.
3	0.0013	-232.	23	0.2488	-675.
4	0.0016	-245.	24	0.7102	-690.
5	0.0021	-276.	25	2.2325	-686.
6	0.0027	-304.	26	4.9959	-717.
7	0.0032	-353.	27	5.7633	-691.
8	0.0035	-387.	28	7.2866	-688.
9	0.0041	-417.	29	8.8658	-687.
10	0.0046	-448.	30	15.0647	-690.
11	0.0049	-479.	31	22.5499	-703.
12	0.0052	-476.	32	27.2436	-700.
13	0.0058	-526.	33	38.4920	-696.
14	0.0063	-552.	34	42.4738	-695.
15	0.0066	-583.			
16	0.0072	-618.			
17	0.0074	-629.			
18	0.0077	-644.			
19	0.0083	-696.			
20	0.0085	-706.			

Specimen No. 2 - Step No. 7 - Initial Time = 280.524 Hours

STEP RESPONSE			RELAXATION		
	TIME (Hrs)	Ø STRAIN (Micro)		TIME (Hrs)	Ø STRAIN (Micro)
1	0.0004	1369.	22	0.0131	2447.
2	0.0009	1461.	23	0.1345	2433.
3	0.0012	1494.	24	0.2959	2447.
4	0.0015	1543.	25	0.4626	2430.
5	0.0018	1564.	26	0.6101	2427.
6	0.0020	1613.	27	0.7370	2429.
7	0.0023	1658.	28	0.9403	2426.
8	0.0026	1695.	29	1.0802	2429.
9	0.0032	1776.	30	1.4169	2427.
10	0.0037	1841.	31	1.6406	2431.
11	0.0043	1923.	32	2.3408	2434.
12	0.0049	2003.	33	2.7452	2435.
13	0.0054	2085.	34	3.4976	2435.
14	0.0057	2134.	35	4.4360	2437.
15	0.0060	2151.	36	5.1069	2439.
16	0.0065	2233.	37	7.5565	2454.
17	0.0068	2265.	38	8.9685	2456.
18	0.0071	2315.	39	11.6885	2449.
19	0.0076	2397.	40	14.6363	2442.
20	0.0079	2411.	41	17.2653	2440.
21	0.0085	2460.	42	23.3340	2439.
			43	27.0474	2439.
			44	38.0539	2440.
			45	43.8521	2441.

Specimen No. 2 - Step No. 7 - Initial Time = 280.524 Hours

STEP RESPONSE			RELAXATION		
	TIME (Hrs)	STRESS (Ksi)		TIME (Hrs)	STRESS (Ksi)
1	0.0004	3.151	22	0.0131	5.911
2	0.0009	3.325	23	0.1345	5.759
3	0.0012	3.433	24	0.2959	5.731
4	0.0015	3.544	25	0.4626	5.715
5	0.0018	3.673	26	0.6101	5.714
6	0.0020	3.781	27	0.7370	5.704
7	0.0023	3.868	28	0.9403	5.693
8	0.0026	3.996	29	1.0802	5.684
9	0.0032	4.192	30	1.4169	5.675
10	0.0037	4.409	31	1.6406	5.669
11	0.0043	4.605	32	2.3408	5.659
12	0.0049	4.844	33	2.7452	5.655
13	0.0054	5.042	34	3.4976	5.647
14	0.0057	5.150	35	4.4360	5.634
15	0.0060	5.215	36	5.1069	5.632
16	0.0065	5.408	37	7.5565	5.631
17	0.0068	5.517	38	8.9685	5.633
18	0.0071	5.604	39	11.6885	5.607
19	0.0076	5.799	40	14.6363	5.577
20	0.0079	5.886	41	17.2653	5.559
21	0.0085	6.078	42	23.3340	5.525
			43	27.0474	5.513
			44	38.0539	5.491
			45	43.8521	5.481

Specimen No. 2 - Step No. 7 - Initial Time = 280.524 Hours

STEP RESPONSE			RELAXATION		
	TIME (Hrs)	90 STRAIN (Micro)		TIME (Hrs)	90 STRAIN (Micro)
1	0.0004	-742.	22	0.0131	-1469.
2	0.0009	-804.	23	0.1345	-1469.
3	0.0012	-835.	24	0.2959	-1427.
4	0.0015	-866.	25	0.4626	-1453.
5	0.0018	-874.	26	0.6101	-1451.
6	0.0020	-890.	27	0.7370	-1451.
7	0.0023	-928.	28	0.9403	-1449.
8	0.0026	-959.	29	1.0802	-1449.
9	0.0032	-982.	30	1.4169	-1453.
10	0.0037	-1028.	31	1.6406	-1455.
11	0.0043	-1089.	32	2.3408	-1461.
12	0.0049	-1160.	33	2.7452	-1464.
13	0.0054	-1221.	34	3.4976	-1468.
14	0.0057	-1237.	35	4.4360	-1470.
15	0.0060	-1252.	36	5.1069	-1471.
16	0.0065	-1314.	37	7.5565	-1476.
17	0.0068	-1356.	38	8.9685	-1472.
18	0.0071	-1350.	39	11.6885	-1468.
19	0.0076	-1422.	40	14.6363	-1466.
20	0.0079	-1427.	41	17.2653	-1467.
21	0.0085	-1473.	42	23.3340	-1475.
			43	27.0474	-1478.
			44	38.0539	-1479.
			45	43.8521	-1479.

Specimen No. 2 - Step No. 8 - Initial Time = 327.828 Hours

STEP RESPONSE			RELAXATION		
	TIME (Hrs)	Ø STRAIN (Micro)		TIME (Hrs)	Ø STRAIN (Micro)
1	0.0006	2529.	21	0.0712	3753.
2	0.0009	2594.	22	0.3040	3718.
3	0.0015	2640.	23	0.3800	3724.
4	0.0020	2737.	24	0.4293	3722.
5	0.0023	2786.	25	0.5649	3713.
6	0.0026	2841.	26	0.6998	3706.
7	0.0032	2900.	27	1.1456	3723.
8	0.0034	2965.	28	2.3161	3726.
9	0.0040	3071.	29	2.6628	3717.
10	0.0043	3096.	30	3.5945	3713.
11	0.0045	3145.	31	4.3243	3723.
12	0.0048	3218.	32	7.1779	3732.
13	0.0054	3284.	33	9.0141	3731.
14	0.0057	3308.	34	11.8883	3735.
15	0.0062	3405.	35	12.8856	3736.
16	0.0068	3487.	36	18.2744	3730.
17	0.0070	3536.	37	23.8734	3727.
18	0.0076	3645.	38	28.0469	3729.
19	0.0082	3727.	39	37.0553	3733.
20	0.0084	3760.	40	41.4390	3737.
			41	56.2681	3742.
			42	72.0370	3746.

Specimen No. 2 - Step No. 8 - Initial Time = 327.828 Hours

STEP RESPONSE			RELAXATION		
	TIME (Hrs)	STRESS (Ksi)		TIME (Hrs)	STRESS (Ksi)
1	0.0006	5.691	21	0.0712	8.562
2	0.0009	5.849	22	0.3040	8.456
3	0.0015	6.103	23	0.3800	8.435
4	0.0020	6.367	24	0.4293	8.425
5	0.0023	6.447	25	0.5649	8.411
6	0.0026	6.581	26	0.6998	8.404
7	0.0032	6.780	27	1.1456	8.345
8	0.0034	6.907	28	2.3161	8.299
9	0.0040	7.146	29	2.6628	8.284
10	0.0043	7.272	30	3.5945	8.263
11	0.0045	7.381	31	4.3243	8.253
12	0.0048	7.493	32	7.1779	8.215
13	0.0054	7.732	33	9.0141	8.191
14	0.0057	7.841	34	11.8883	8.157
15	0.0062	8.062	35	12.8856	8.149
16	0.0068	8.297	36	18.2744	8.106
17	0.0070	8.362	37	23.8734	8.073
18	0.0076	8.575	38	28.0469	8.060
19	0.0082	8.797	39	37.0553	8.034
20	0.0084	8.883	40	41.4390	8.024
			41	56.2681	7.996
			42	72.0370	7.975



Specimen No. 2 - Step No. 8 - Initial Time = 327.828 Hours

STEP RESPONSE			RELAXATION		
	TIME (Hrs)	90 STRAIN (Micro)		TIME (Hrs)	90 STRAIN (Micro)
1	0.0006	-1531.	21	0.0712	-2350.
2	0.0009	-1577.	22	0.3040	-2323.
3	0.0015	-1623.	23	0.3800	-2324.
4	0.0020	-1672.	24	0.4293	-2323.
5	0.0023	-1689.	25	0.5649	-2325.
6	0.0026	-1718.	26	0.6998	-2330.
7	0.0032	-1795.	27	1.1456	-2341.
8	0.0034	-1824.	28	2.3161	-2361.
9	0.0040	-1871.	29	2.6628	-2352.
10	0.0043	-1902.	30	3.5945	-2346.
11	0.0045	-1917.	31	4.3243	-2350.
12	0.0048	-1979.	32	7.1779	-2366.
13	0.0054	-2025.	33	9.0141	-2366.
14	0.0057	-2040.	34	11.8883	-2371.
15	0.0062	-2102.	35	12.8856	-2379.
16	0.0068	-2163.	36	18.2744	-2375.
17	0.0070	-2196.	37	23.8734	-2376.
18	0.0076	-2273.	38	28.0469	-2379.
19	0.0082	-2335.	39	37.0553	-2384.
20	0.0084	-2347.	40	41.4390	-2387.
			41	56.2681	-2395.
			42	72.0370	-2397.

Specimen No. 2 - Step No. 9 - Initial Time = 406.564 Hours

STEP RESPONSE			RELAXATION		
	TIME (Hrs)	Ø STRAIN (Micro)		TIME (Hrs)	Ø STRAIN (Micro)
1	0.0003	3842.	23	0.0305	5181.
2	0.0006	3875.	24	0.1036	5246.
3	0.0011	4007.	25	0.2364	5181.
4	0.0014	4039.	26	0.5069	5243.
5	0.0017	4105.	27	0.6964	5233.
6	0.0020	4154.	28	0.8575	5222.
7	0.0023	4204.	29	1.1337	5222.
8	0.0028	4286.	30	1.4318	5229.
9	0.0031	4335.	31	1.7616	5235.
10	0.0036	4433.	32	2.4506	5246.
11	0.0039	4466.	33	2.6094	5253.
12	0.0042	4497.	34	7.0632	5247.
13	0.0048	4614.	35	8.9688	5244.
14	0.0050	4663.	36	11.7124	5250.
15	0.0056	4745.	37	15.4065	5252.
16	0.0061	4865.	38	16.0851	5255.
17	0.0064	4915.	39	22.7921	5271.
18	0.0070	4975.	40	26.1502	5291.
19	0.0073	5041.	41	39.9051	5275.
20	0.0078	5139.			
21	0.0081	5172.			
22	0.0084	5238.			

Specimen No. 2 - Step No. 9 - Initial Time = 406.564 Hours

STEP RESPONSE			RELAXATION		
	TIME (Hrs)	STRESS (Ksi)		TIME (Hrs)	STRESS (Ksi)
1	0.0003	8.210	23	0.0305	11.435
2	0.0006	8.340	24	0.1036	11.262
3	0.0011	8.666	25	0.2364	11.196
4	0.0014	8.758	26	0.5069	11.072
5	0.0017	8.883	27	0.6964	11.050
6	0.0020	9.009	28	0.8575	11.012
7	0.0023	9.144	29	1.1337	10.987
8	0.0028	9.383	30	1.4318	10.958
9	0.0031	9.513	31	1.7616	10.929
10	0.0036	9.752	32	2.4506	10.871
11	0.0039	9.883	33	2.6094	10.866
12	0.0042	9.986	34	7.0632	10.698
13	0.0048	10.208	35	8.9688	10.608
14	0.0050	10.317	36	11.7124	10.623
15	0.0056	10.556	37	15.4065	10.573
16	0.0061	10.757	38	16.0851	10.563
17	0.0064	10.882	39	22.7921	10.539
18	0.0070	11.137	40	26.1502	10.555
19	0.0073	11.202	41	39.9051	10.415
20	0.0078	11.446			
21	0.0081	11.571			
22	0.0084	11.685			

Specimen No. 2 - Step No. 9 - Initial Time = 406.564 Hours

STEP RESPONSE

RELAXATION

STEP RESPONSE			RELAXATION		
	TIME (Hrs)	90 STRAIN (Micro)		TIME (Hrs)	90 STRAIN (Micro)
1	0.0003	-2454.	23	0.0305	-3359.
2	0.0006	-2520.	24	0.1036	-3417.
3	0.0011	-2567.	25	0.2364	-3348.
4	0.0014	-2577.	26	0.5869	-3415.
5	0.0017	-2608.	27	0.6964	-3402.
6	0.0020	-2638.	28	0.8575	-3390.
7	0.0023	-2669.	29	1.1337	-3411.
8	0.0028	-2746.	30	1.4318	-3425.
9	0.0031	-2777.	31	1.7616	-3439.
10	0.0036	-2838.	32	2.4506	-3491.
11	0.0039	-2846.	33	2.6094	-3443.
12	0.0042	-2899.	34	7.0632	-3464.
13	0.0048	-2961.	35	8.8688	-3467.
14	0.0050	-2991.	36	11.7124	-3471.
15	0.0056	-3029.	37	15.4065	-3473.
16	0.0061	-3139.	38	16.0851	-3470.
17	0.0064	-3154.	39	22.7921	-3481.
18	0.0070	-3191.	40	26.1502	-3495.
19	0.0073	-3237.	41	39.9051	-3504.
20	0.0078	-3272.			
21	0.0081	-3329.			
22	0.0084	-3333.			

Specimen No. 3 - Step No. 4 - Initial Time = 135.787 Hours

STEP RESPONSE			RELAXATION			
	TIME (Hrs)	Ø STRAIN (Micro)		TIME (Hrs)	Ø STRAIN (Micro)	
	1	0.0008	232.	17	0.1515	415.
	2	0.0013	247.	18	11.8435	435.
	3	0.0016	247.	19	13.5828	432.
	4	0.0022	264.	20	17.0824	423.
	5	0.0027	316.	21	29.4640	413.
	6	0.0033	311.	22	35.4628	422.
	7	0.0038	316.	23	46.5730	430.
	8	0.0044	313.			
	9	0.0049	350.			
	10	0.0055	346.			
	11	0.0060	376.			
	12	0.0065	379.			
	13	0.0071	389.			
	14	0.0074	412.			
	15	0.0079	412.			
	16	0.0085	445.			

Specimen No. 3 - Step No. 4 - Initial Time = 135.787 Hours

STEP RESPONSE			RELAXATION			
	TIME (Hrs)	STRESS (Ksi)		TIME (Hrs)	STRESS (Ksi)	
	1	0.0008	0.283	17	0.1515	0.720
	2	0.0013	0.305	18	11.8435	0.717
	3	0.0016	0.305	19	13.5828	0.709
	4	0.0022	0.349	20	17.0824	0.688
	5	0.0027	0.392	21	29.4640	0.662
	6	0.0033	0.414	22	35.4628	0.672
	7	0.0038	0.458	23	46.5730	0.683
	8	0.0044	0.480			
	9	0.0049	0.523			
	10	0.0055	0.567			
	11	0.0060	0.588			
	12	0.0065	0.632			
	13	0.0071	0.676			
	14	0.0074	0.697			
	15	0.0079	0.741			
	16	0.0085	0.806			

Specimen No. 3 - Step No. 4 - Initial Time = 135.787 Hours

STEP RESPONSE			RELAXATION		
	TIME (Hrs)	90 STRAIN (Micro)		TIME (Hrs)	90 STRAIN (Micro)
1	0.0008	-741.	17	0.1515	-871.
2	0.0013	-747.	18	11.8435	-853.
3	0.0016	-741.	19	13.5828	-858.
4	0.0022	-756.	20	17.0824	-864.
5	0.0027	-750.	21	29.4640	-857.
6	0.0033	-750.	22	35.4628	-852.
7	0.0038	-772.	23	46.5730	-847.
8	0.0044	-766.			
9	0.0049	-781.			
10	0.0055	-781.			
11	0.0060	-812.			
12	0.0065	-796.			
13	0.0071	-827.			
14	0.0074	-827.			
15	0.0079	-856.			
16	0.0085	-864.			

Specimen No. 3 - Step No. 5 - Initial Time = 183.798 Hours

STEP RESPONSE			RELAXATION		
	TIME (Hrs)	Ø STRAIN (Micro)		TIME (Hrs)	Ø STRAIN (Micro)
1	0.0008	498.	17	0.0306	1071.
2	0.0014	519.	18	0.3075	1042.
3	0.0016	544.	19	0.7117	1041.
4	0.0022	589.	20	0.8897	1038.
5	0.0028	626.	21	1.1480	1040.
6	0.0033	643.	22	1.3635	1039.
7	0.0038	709.	23	1.9329	1040.
8	0.0041	709.	24	2.2373	1038.
9	0.0046	758.	25	2.8244	1037.
10	0.0052	807.	26	3.5785	1036.
11	0.0057	840.	27	4.3996	1036.
12	0.0063	890.	28	5.6764	1035.
13	0.0069	939.	29	7.2112	1035.
14	0.0074	996.	30	8.6007	1035.
15	0.0080	1038.	31	11.1995	1037.
16	0.0085	1096.	32	14.7932	1037.
			33	17.5067	1037.
			34	21.9163	1030.
			35	27.5385	1035.
			36	34.2924	1028.
			37	46.1974	1023.
			38	50.2135	1021.

Specimen No. 3 - Step No. 5 - Initial Time = 183.798 Hours

STEP RESPONSE			RELAXATION		
	TIME (Hrs)	STRESS (Ksi)		TIME (Hrs)	STRESS (Ksi)
1	0.0008	0.850	17	0.0306	2.268
2	0.0014	0.894	18	0.3075	2.192
3	0.0016	0.960	19	0.7117	2.177
4	0.0022	1.068	20	0.8897	2.171
5	0.0028	1.156	21	1.1480	2.166
6	0.0033	1.265	22	1.3635	2.166
7	0.0038	1.353	23	1.9329	2.162
8	0.0041	1.417	24	2.2373	2.161
9	0.0046	1.526	25	2.8244	2.154
10	0.0052	1.636	26	3.5785	2.149
11	0.0057	1.766	27	4.3996	2.144
12	0.0063	1.854	28	5.6764	2.136
13	0.0069	1.983	29	7.2112	2.129
14	0.0074	2.093	30	8.6007	2.127
15	0.0080	2.201	31	11.1995	2.125
16	0.0085	2.355	32	14.7932	2.114
			33	17.5067	2.104
			34	21.9163	2.086
			35	27.5385	2.090
			36	34.2924	2.088
			37	46.1974	2.067
			38	50.2135	2.058

Specimen No. 3 - Step No. 5 - Initial Time = 183.798 Hours

STEP RESPONSE

RELAXATION

STEP RESPONSE			RELAXATION		
	TIME (Hrs)	90 STRAIN (Micro)		TIME (Hrs)	90 STRAIN (Micro)
1	0.0008	-880.	17	0.0306	-1296.
2	0.0014	-933.	18	0.3075	-1294.
3	0.0016	-941.	19	0.7117	-1285.
4	0.0022	-949.	20	0.8897	-1285.
5	0.0028	-988.	21	1.1480	-1288.
6	0.0033	-1027.	22	1.3635	-1287.
7	0.0038	-1026.	23	1.9329	-1285.
8	0.0041	-1049.	24	2.2373	-1281.
9	0.0046	-1080.	25	2.8244	-1282.
10	0.0052	-1120.	26	3.5785	-1282.
11	0.0057	-1151.	27	4.3996	-1280.
12	0.0063	-1173.	28	5.6764	-1279.
13	0.0069	-1194.	29	7.2112	-1277.
14	0.0074	-1235.	30	8.6007	-1275.
15	0.0080	-1266.	31	11.1995	-1273.
16	0.0085	-1296.	32	14.7932	-1270.
			33	17.5067	-1267.
			34	21.9163	-1270.
			35	27.5385	-1277.
			36	34.2924	-1286.
			37	46.1974	-1279.
			38	50.2135	-1277.

Specimen No. 3 - Step No. 6 - Initial Time = 235.859 Hours

STEP RESPONSE			RELAXATION		
	TIME (Hrs)	Ø STRAIN (Micro)		TIME (Hrs)	Ø STRAIN (Micro)
1	0.0006	1104.	21	0.0119	2109.
2	0.0008	1162.	22	0.0538	2142.
3	0.0013	1210.	23	0.2488	2060.
4	0.0016	1250.	24	0.7102	2109.
5	0.0021	1351.	25	2.2325	2095.
6	0.0027	1401.	26	4.9959	2092.
7	0.0032	1483.	27	5.7633	2092.
8	0.0035	1516.	28	7.2866	2093.
9	0.0041	1611.	29	8.8658	2091.
10	0.0046	1652.	30	15.0647	2076.
11	0.0049	1681.	31	22.5499	2082.
12	0.0052	1747.	32	27.2436	2087.
13	0.0058	1843.	33	38.4920	2092.
14	0.0063	1910.	34	42.4738	2092.
15	0.0066	1928.			
16	0.0072	2008.			
17	0.0074	2043.			
18	0.0077	2028.			
19	0.0083	2159.			
20	0.0085	2159.			

Specimen No. 3 - Step No. 6 - Initial Time = 235.859 Hours

STEP RESPONSE			RELAXATION		
	TIME (Hrs)	STRESS (Ksi)		TIME (Hrs)	STRESS (Ksi)
1	0.0006	2.247	21	0.0119	4.797
2	0.0008	2.399	22	0.0538	4.691
3	0.0013	2.551	23	0.2488	4.642
4	0.0016	2.659	24	0.7102	4.579
5	0.0021	2.855	25	2.2325	4.564
6	0.0027	3.073	26	4.9959	4.516
7	0.0032	3.247	27	5.7633	4.535
8	0.0035	3.336	28	7.2866	4.529
9	0.0041	3.532	29	8.8658	4.522
10	0.0046	3.705	30	15.0647	4.502
11	0.0049	3.794	31	22.5499	4.452
12	0.0052	3.881	32	27.2436	4.445
13	0.0058	4.078	33	38.4920	4.423
14	0.0063	4.252	34	42.4738	4.413
15	0.0066	4.359			
16	0.0072	4.494			
17	0.0074	4.598			
18	0.0077	4.666			
19	0.0083	4.860			
20	0.0085	4.925			



Specimen No. 3 - Step No. 6 - Initial Time = 235.859 Hours

STEP RESPONSE			RELAXATION		
	TIME (Hrs)	90 STRAIN (Micro)		TIME (Hrs)	90 STRAIN (Micro)
1	0.0006	-1343.	21	0.0119	-2068.
2	0.0008	-1374.	22	0.0538	-2069.
3	0.0013	-1409.	23	0.2488	-2022.
4	0.0016	-1440.	24	0.7102	-2053.
5	0.0021	-1485.	25	2.2325	-2049.
6	0.0027	-1571.	26	4.9959	-2068.
7	0.0032	-1593.	27	5.7633	-2044.
8	0.0035	-1623.	28	7.2866	-2043.
9	0.0041	-1682.	29	8.8658	-2043.
10	0.0046	-1744.	30	15.0647	-2045.
11	0.0049	-1773.	31	22.5499	-2064.
12	0.0052	-1790.	32	27.2436	-2064.
13	0.0058	-1851.	33	38.4920	-2064.
14	0.0063	-1884.	34	42.4738	-2064.
15	0.0066	-1914.			
16	0.0072	-1976.			
17	0.0074	-1991.			
18	0.0077	-2006.			
19	0.0083	-2068.			
20	0.0085	-2067.			

Specimen No. 3 - Step No. 7 - Initial Time = 280.524 Hours

STEP RESPONSE			RELAXATION		
	TIME (Hrs)	Ø STRAIN (Micro)		TIME (Hrs)	Ø STRAIN (Micro)
1	0.0004	2192.	22	0.0131	3464.
2	0.0009	2292.	23	0.1345	3388.
3	0.0012	2326.	24	0.2959	3411.
4	0.0015	2393.	25	0.4626	3365.
5	0.0018	2388.	26	0.6101	3392.
6	0.0020	2472.	27	0.7370	3402.
7	0.0023	2502.	28	0.9403	3401.
8	0.0026	2574.	29	1.0802	3401.
9	0.0032	2637.	30	1.4169	3407.
10	0.0037	2735.	31	1.6406	3403.
11	0.0043	2775.	32	2.3408	3400.
12	0.0049	2933.	33	2.7452	3400.
13	0.0054	3022.	34	3.4976	3402.
14	0.0057	3072.	35	4.4360	3404.
15	0.0060	3082.	36	5.1069	3407.
16	0.0065	3213.	37	7.5565	3417.
17	0.0068	3255.	38	8.9685	3414.
18	0.0071	3279.	39	11.6885	3407.
19	0.0076	3345.	40	14.6363	3401.
20	0.0079	3395.	41	17.2653	3399.
21	0.0085	3424.	42	23.3340	3396.
			43	27.0474	3397.
			44	38.0539	3404.
			45	43.8521	3405.

Specimen No. 3 - Step No. 7 - Initial Time = 280.524 Hours

STEP RESPONSE			RELAXATION		
	TIME (Hrs)	STRESS (Ksi)		TIME (Hrs)	STRESS (Ksi)
1	0.0004	4.620	22	0.0131	7.610
2	0.0009	4.816	23	0.1345	7.366
3	0.0012	4.969	24	0.2959	7.319
4	0.0015	5.078	25	0.4626	7.305
5	0.0018	5.187	26	0.6101	7.268
6	0.0020	5.296	27	0.7370	7.249
7	0.0023	5.429	28	0.9403	7.239
8	0.0026	5.536	29	1.0802	7.233
9	0.0032	5.775	30	1.4169	7.216
10	0.0037	5.971	31	1.6406	7.208
11	0.0043	6.189	32	2.3408	7.184
12	0.0049	6.448	33	2.7452	7.174
13	0.0054	6.647	34	3.4976	7.158
14	0.0057	6.734	35	4.4360	7.144
15	0.0060	6.865	36	5.1069	7.138
16	0.0065	7.061	37	7.5565	7.120
17	0.0068	7.152	38	8.9685	7.111
18	0.0071	7.261	39	11.6885	7.079
19	0.0076	7.479	40	14.6363	7.045
20	0.0079	7.562	41	17.2653	7.022
21	0.0085	7.741	42	23.3340	6.983
			43	27.0474	6.970
			44	38.0539	6.935
			45	43.8521	6.918

Specimen No. 3 - Step No. 7 - Initial Time = 280.524 Hours

STEP RESPONSE			RELAXATION		
	TIME (Hrs)	90 STRAIN (Micro)		TIME (Hrs)	90 STRAIN (Micro)
1	0.0004	-2114.	22	0.0131	-3049.
2	0.0009	-2192.	23	0.1345	-3049.
3	0.0012	-2222.	24	0.2959	-2971.
4	0.0015	-2253.	25	0.4626	-3014.
5	0.0018	-2300.	26	0.6101	-3012.
6	0.0020	-2315.	27	0.7370	-3012.
7	0.0023	-2346.	28	0.9403	-3016.
8	0.0026	-2377.	29	1.0802	-3015.
9	0.0032	-2420.	30	1.4169	-3020.
10	0.0037	-2500.	31	1.6406	-3022.
11	0.0043	-2547.	32	2.3408	-3030.
12	0.0049	-2660.	33	2.7452	-3039.
13	0.0054	-2701.	34	3.4976	-3047.
14	0.0057	-2747.	35	4.4360	-3049.
15	0.0060	-2800.	36	5.1069	-3053.
16	0.0065	-2840.	37	7.5565	-3048.
17	0.0068	-2855.	38	8.9685	-3041.
18	0.0071	-2902.	39	11.6885	-3036.
19	0.0076	-2987.	40	14.6363	-3036.
20	0.0079	-2994.	41	17.2653	-3040.
21	0.0085	-3040.	42	23.3340	-3050.
			43	27.0474	-3056.
			44	38.0539	-3059.
			45	43.8521	-3061.

Specimen No. 3 - Step No. 8 - Initial Time = 327.828 Hours

STEP RESPONSE			RELAXATION		
	TIME (Hrs)	Ø STRAIN (Micro)		TIME (Hrs)	Ø STRAIN (Micro)
1	0.0006	3521.	21	0.0712	4795.
2	0.0009	3554.	22	0.3040	4851.
3	0.0015	3687.	23	0.3800	4851.
4	0.0020	3799.	24	0.4293	4849.
5	0.0023	3790.	25	0.5649	4824.
6	0.0026	3827.	26	0.6998	4800.
7	0.0032	3922.	27	1.1456	4809.
8	0.0034	3971.	28	2.3161	4863.
9	0.0040	4102.	29	2.6628	4839.
10	0.0043	4136.	30	3.5945	4821.
11	0.0045	4153.	31	4.3243	4829.
12	0.0048	4235.	32	7.1779	4834.
13	0.0054	4368.	33	9.0141	4820.
14	0.0057	4401.	34	11.8883	4815.
15	0.0062	4449.	35	12.8856	4816.
16	0.0068	4583.	36	18.2744	4844.
17	0.0070	4614.	37	23.8734	4830.
18	0.0076	4696.	38	28.0469	4831.
19	0.0082	4799.	39	37.0553	4841.
20	0.0084	4866.	40	41.4390	4846.
			41	56.2681	4843.
			42	72.0370	4838.

Specimen No. 3 - Step No. 8 - Initial Time = 327.828 Hours

STEP RESPONSE			RELAXATION		
	TIME (Hrs)	STRESS (Ksi)		TIME (Hrs)	STRESS (Ksi)
1	0.0006	7.108	21	0.0712	9.987
2	0.0009	7.283	22	0.3040	9.862
3	0.0015	7.519	23	0.3800	9.836
4	0.0020	7.759	24	0.4293	9.825
5	0.0023	7.868	25	0.5649	9.814
6	0.0026	7.977	26	0.6998	9.797
7	0.0032	8.238	27	1.1456	9.723
8	0.0034	8.343	28	2.3161	9.650
9	0.0040	8.587	29	2.6628	9.638
10	0.0043	8.691	30	3.5945	9.615
11	0.0045	8.817	31	4.3243	9.599
12	0.0048	8.914	32	7.1779	9.541
13	0.0054	9.153	33	9.0141	9.506
14	0.0057	9.284	34	11.8883	9.451
15	0.0062	9.497	35	12.8856	9.441
16	0.0068	9.698	36	18.2744	9.404
17	0.0070	9.807	37	23.8734	9.364
18	0.0076	10.020	38	28.0469	9.343
19	0.0082	10.248	39	37.0553	9.303
20	0.0084	10.330	40	41.4390	9.289
			41	56.2681	9.248
			42	72.0370	9.214

Specimen No. 3 - Step No. 8 - Initial Time = 327.828 Hours

STEP RESPONSE			RELAXATION		
	TIME (Hrs)	90 STRAIN (Micro)		TIME (Hrs)	90 STRAIN (Micro)
1	0.0006	-3142.	21	0.0712	-4074.
2	0.0009	-3124.	22	0.3040	-4065.
3	0.0015	-3201.	23	0.3800	-4080.
4	0.0020	-3313.	24	0.4293	-4081.
5	0.0023	-3303.	25	0.5649	-4071.
6	0.0026	-3334.	26	0.6998	-4057.
7	0.0032	-3411.	27	1.1456	-4103.
8	0.0034	-3442.	28	2.3161	-4114.
9	0.0040	-3492.	29	2.6628	-4101.
10	0.0043	-3538.	30	3.5945	-4100.
11	0.0045	-3581.	31	4.3243	-4115.
12	0.0048	-3627.	32	7.1779	-4132.
13	0.0054	-3704.	33	9.0141	-4132.
14	0.0057	-3720.	34	11.8883	-4162.
15	0.0062	-3827.	35	12.8856	-4177.
16	0.0068	-3858.	36	18.2744	-4163.
17	0.0070	-3935.	37	23.8734	-4151.
18	0.0076	-3998.	38	28.0469	-4155.
19	0.0082	-4060.	39	37.0553	-4157.
20	0.0084	-4074.	40	41.4390	-4159.
			41	56.2681	-4170.
			42	72.0370	-4173.

Specimen No. 3 - Step No. 9 - Initial Time = 406.564 Hours

STEP RESPONSE			RELAXATION		
	TIME (Hrs)	Ø STRAIN (Micro)		TIME (Hrs)	Ø STRAIN (Micro)
1	0.0003	4890.	23	0.0305	6394.
2	0.0006	4993.	24	0.1036	6510.
3	0.0011	5037.	25	0.2364	6427.
4	0.0014	5198.	26	0.5869	6454.
5	0.0017	5191.	27	0.6964	6440.
6	0.0020	5217.	28	0.8575	6410.
7	0.0023	5364.	29	1.1337	6474.
8	0.0028	5533.	30	1.4318	6484.
9	0.0031	5454.	31	1.7616	6481.
10	0.0036	5570.	32	2.4506	6493.
11	0.0039	5663.	33	2.6094	6479.
12	0.0042	5669.	34	7.0632	6511.
13	0.0048	5724.	35	8.8688	6509.
14	0.0050	5789.	36	11.7124	6519.
15	0.0056	5871.	37	15.4065	6523.
16	0.0061	6045.	38	16.0851	6525.
17	0.0064	6064.	39	22.7921	6540.
18	0.0070	6116.	40	26.1502	6549.
19	0.0073	6310.	41	39.9051	6560.
20	0.0078	6360.			
21	0.0081	6329.			
22	0.0084	6410.			

Specimen No. 3 - Step No. 9 - Initial Time = 406.564 Hours

STEP RESPONSE			RELAXATION		
	TIME (Hrs)	STRESS (Ksi)		TIME (Hrs)	STRESS (Ksi)
1	0.0003	9.415	23	0.0305	12.627
2	0.0006	9.546	24	0.1036	12.466
3	0.0011	9.873	25	0.2364	12.394
4	0.0014	9.982	26	0.5869	12.251
5	0.0017	10.063	27	0.6964	12.228
6	0.0020	10.221	28	0.8575	12.198
7	0.0023	10.330	29	1.1337	12.159
8	0.0028	10.570	30	1.4318	12.122
9	0.0031	10.695	31	1.7616	12.086
10	0.0036	10.929	32	2.4506	12.015
11	0.0039	11.044	33	2.6094	12.007
12	0.0042	11.202	34	7.0632	11.831
13	0.0048	11.392	35	8.8688	11.792
14	0.0050	11.507	36	11.7124	11.741
15	0.0056	11.725	37	15.4065	11.682
16	0.0061	11.937	38	16.0851	11.670
17	0.0064	12.067	39	22.7921	11.628
18	0.0070	12.292	40	26.1502	11.627
19	0.0073	12.422	41	39.9051	11.485
20	0.0078	12.634			
21	0.0081	12.721			
22	0.0084	12.852			

Specimen No. 3 - Step No. 9 - Initial Time = 406.564 Hours

STEP RESPONSE			RELAXATION			
	TIME (Hrs)	90 STRAIN (Micro)		TIME (Hrs)	90 STRAIN (Micro)	
	1	0.0003	-4211.	23	0.0305	-5253.
	2	0.0006	-4291.	24	0.1036	-5425.
	3	0.0011	-4368.	25	0.2364	-5227.
	4	0.0014	-4414.	26	0.5869	-5352.
	5	0.0017	-4395.	27	0.6964	-5345.
	6	0.0020	-4441.	28	0.8575	-5314.
	7	0.0023	-4507.	29	1.1337	-5355.
	8	0.0028	-4548.	30	1.4318	-5377.
	9	0.0031	-4564.	31	1.7616	-5395.
	10	0.0036	-4676.	32	2.4506	-5472.
	11	0.0039	-4686.	33	2.6094	-5421.
	12	0.0042	-4717.	34	7.0632	-5421.
	13	0.0048	-4800.	35	8.8688	-5432.
	14	0.0050	-4862.	36	11.7124	-5445.
	15	0.0056	-4923.	37	15.4065	-5465.
	16	0.0061	-4985.	38	16.0851	-5465.
	17	0.0064	-5031.	39	22.7921	-5449.
	18	0.0070	-5133.	40	26.1502	-5457.
	19	0.0073	-5139.	41	39.9051	-5516.
	20	0.0078	-5145.			
	21	0.0081	-5207.			
	22	0.0084	-5263.			

Specimen No. 4 - Step No. 3 - Initial Time = 88.559 Hours

STEP RESPONSE			RELAXATION		
	TIME (Hrs)	Ø STRAIN (Micro)		TIME (Hrs)	Ø STRAIN (Micro)
1	0.0004	292.	17	0.0137	474.
2	0.0010	302.	18	0.4560	469.
3	0.0012	324.	19	0.5972	457.
4	0.0018	338.	20	0.6718	464.
5	0.0023	336.	21	1.3965	463.
6	0.0029	355.	22	1.8726	464.
7	0.0035	369.	23	2.2135	464.
8	0.0040	389.	24	2.6036	467.
9	0.0046	409.	25	3.6454	465.
10	0.0051	426.	26	4.8639	463.
11	0.0056	423.	27	5.8379	463.
12	0.0062	440.	28	6.8367	464.
13	0.0067	460.	29	8.8938	465.
14	0.0073	474.	30	11.2294	465.
15	0.0078	494.	31	15.2110	462.
16	0.0084	508.	32	17.8373	459.
			33	22.0747	476.
			34	28.3453	481.
			35	36.1319	484.
			36	44.9298	479.

Specimen No. 4 - Step No. 3 - Initial Time = 88.559 Hours

STEP RESPONSE			RELAXATION		
	TIME (Hrs)	STRESS (Ksi)		TIME (Hrs)	STRESS (Ksi)
1	0.0004	0.089	17	0.0137	0.559
2	0.0010	0.134	18	0.4560	0.512
3	0.0012	0.179	19	0.5972	0.492
4	0.0018	0.223	20	0.6718	0.514
5	0.0023	0.246	21	1.3965	0.514
6	0.0029	0.290	22	1.8726	0.506
7	0.0035	0.291	23	2.2135	0.507
8	0.0040	0.335	24	2.6036	0.508
9	0.0046	0.358	25	3.6454	0.505
10	0.0051	0.424	26	4.8639	0.497
11	0.0056	0.424	27	5.8379	0.497
12	0.0062	0.469	28	6.8367	0.497
13	0.0067	0.492	29	8.8938	0.499
14	0.0073	0.536	30	11.2294	0.494
15	0.0078	0.603	31	15.2110	0.488
16	0.0084	0.648	32	17.8373	0.475
			33	21.9113	0.471
			34	28.3108	0.477
			35	36.1319	0.491
			36	44.8627	0.495



Specimen No. 4 - Step No. 3 - Initial Time = 88.559 Hours

STEP RESPONSE			RELAXATION		
	TIME (Hrs)	90 STRAIN (Micro)		TIME (Hrs)	90 STRAIN (Micro)
1	0.0004	-113.	17	0.0137	-208.
2	0.0010	-114.	18	0.4560	-202.
3	0.0012	-113.	19	0.5972	-210.
4	0.0018	-129.	20	0.6718	-202.
5	0.0023	-129.	21	1.3965	-196.
6	0.0029	-145.	22	1.8726	-198.
7	0.0035	-145.	23	2.2135	-194.
8	0.0040	-160.	24	2.6036	-195.
9	0.0046	-162.	25	3.6454	-193.
10	0.0051	-160.	26	4.8639	-196.
11	0.0056	-176.	27	5.8379	-195.
12	0.0062	-192.	28	6.8367	-194.
13	0.0067	-192.	29	8.8938	-189.
14	0.0073	-208.	30	11.2294	-187.
15	0.0078	-210.	31	15.2110	-179.
16	0.0084	-224.	32	17.8373	-182.
			33	21.9113	-181.
			34	28.3108	-179.
			35	36.1319	-177.
			36	44.8627	-180.

Specimen No. 4 - Step No. 4 - Initial Time = 135.787 Hours

STEP RESPONSE			RELAXATION		
	TIME (Hrs)	Ø STRAIN (Micro)		TIME (Hrs)	Ø STRAIN (Micro)
1	0.0008	524.	17	0.1515	784.
2	0.0013	575.	18	11.8435	789.
3	0.0016	575.	19	13.5828	784.
4	0.0022	588.	20	17.0824	776.
5	0.0027	600.	21	29.4640	774.
6	0.0033	638.	22	35.4628	782.
7	0.0038	660.	23	46.5730	791.
8	0.0044	694.			
9	0.0049	705.			
10	0.0055	722.			
11	0.0060	739.			
12	0.0065	755.			
13	0.0071	772.			
14	0.0074	772.			
15	0.0079	806.			
16	0.0085	856.			

Specimen No. 4 - Step No. 4 - Initial Time = 135.787 Hours

STEP RESPONSE			RELAXATION		
	TIME (Hrs)	STRESS (Ksi)		TIME (Hrs)	STRESS (Ksi)
1	0.0008	0.626	17	0.1515	1.296
2	0.0013	0.693	18	11.8435	1.245
3	0.0016	0.738	19	13.5828	1.240
4	0.0022	0.804	20	17.0824	1.228
5	0.0027	0.871	21	29.4640	1.197
6	0.0033	0.894	22	35.4628	1.198
7	0.0038	0.961	23	46.5730	1.205
8	0.0044	1.005			
9	0.0049	1.050			
10	0.0055	1.095			
11	0.0060	1.161			
12	0.0065	1.229			
13	0.0071	1.251			
14	0.0074	1.296			
15	0.0079	1.385			
16	0.0085	1.475			

Specimen No. 4 - Step No. 4 - Initial Time = 135.787 Hours

STEP RESPONSE

RELAXATION

STEP RESPONSE			RELAXATION		
	TIME (Hrs)	90 STRAIN (Micro)		TIME (Hrs)	90 STRAIN (Micro)
1	0.0008	-208.	17	0.1515	-404.
2	0.0013	-240.	18	11.8435	-371.
3	0.0016	-258.	19	13.5828	-375.
4	0.0022	-258.	20	17.0824	-384.
5	0.0027	-256.	21	29.4640	-371.
6	0.0033	-272.	22	35.4628	-364.
7	0.0038	-304.	23	46.5730	-357.
8	0.0044	-304.			
9	0.0049	-318.			
10	0.0055	-318.			
11	0.0060	-336.			
12	0.0065	-353.			
13	0.0071	-369.			
14	0.0074	-385.			
15	0.0079	-401.			
16	0.0085	-420.			

Specimen No. 4 - Step No. 5 - Initial Time = 183.798 Hours

STEP RESPONSE			RELAXATION		
	TIME (Hrs)	Ø STRAIN (Micro)		TIME (Hrs)	Ø STRAIN (Micro)
1	0.0008	873.	17	0.0306	1410.
2	0.0014	921.	18	0.3075	1404.
3	0.0016	940.	19	0.7117	1407.
4	0.0022	990.	20	0.8897	1396.
5	0.0028	1057.	21	1.1480	1392.
6	0.0033	1058.	22	1.3635	1393.
7	0.0038	1125.	23	1.9329	1393.
8	0.0041	1142.	24	2.2373	1393.
9	0.0046	1167.	25	2.8244	1393.
10	0.0052	1201.	26	3.5785	1393.
11	0.0057	1242.	27	4.3996	1391.
12	0.0063	1276.	28	5.6764	1389.
13	0.0069	1326.	29	7.2112	1387.
14	0.0074	1370.	30	8.6007	1386.
15	0.0080	1393.	31	11.1995	1386.
16	0.0085	1466.	32	14.7932	1384.
			33	17.5067	1383.
			34	21.9163	1380.
			35	27.5385	1378.
			36	34.2924	1375.
			37	46.1974	1369.
			38	50.2135	1365.

Specimen No. 4 - Step No. 5 - Initial Time = 183.798 Hours

STEP RESPONSE			RELAXATION		
	TIME (Hrs)	STRESS (Ksi)		TIME (Hrs)	STRESS (Ksi)
1	0.0008	1.430	17	0.0306	2.791
2	0.0014	1.542	18	0.3075	2.715
3	0.0016	1.609	19	0.7117	2.688
4	0.0022	1.720	20	0.8897	2.685
5	0.0028	1.832	21	1.1480	2.675
6	0.0033	1.944	22	1.3635	2.677
7	0.0038	2.012	23	1.9329	2.664
8	0.0041	2.077	24	2.2373	2.667
9	0.0046	2.167	25	2.8244	2.660
10	0.0052	2.279	26	3.5785	2.655
11	0.0057	2.391	27	4.3996	2.646
12	0.0063	2.479	28	5.6764	2.637
13	0.0069	2.613	29	7.2112	2.627
14	0.0074	2.680	30	8.6007	2.620
15	0.0080	2.814	31	11.1995	2.611
16	0.0085	2.925	32	14.7932	2.600
			33	17.5067	2.593
			34	21.9163	2.579
			35	27.5385	2.582
			36	34.2924	2.574
			37	46.1974	2.555
			38	50.2135	2.547

Specimen No. 4 - Step No. 5 - Initial Time = 183.798 Hours

STEP RESPONSE			RELAXATION		
	TIME (Hrs)	90 STRAIN (Micro)		TIME (Hrs)	90 STRAIN (Micro)
1	0.0008	-417.	17	0.0306	-753.
2	0.0014	-452.	18	0.3075	-753.
3	0.0016	-468.	19	0.7117	-764.
4	0.0022	-501.	20	0.8897	-758.
5	0.0028	-513.	21	1.1480	-757.
6	0.0033	-565.	22	1.3635	-754.
7	0.0038	-561.	23	1.9329	-755.
8	0.0041	-598.	24	2.2373	-752.
9	0.0046	-614.	25	2.8244	-755.
10	0.0052	-641.	26	3.5785	-754.
11	0.0057	-657.	27	4.3996	-754.
12	0.0063	-694.	28	5.6764	-750.
13	0.0069	-684.	29	7.2112	-744.
14	0.0074	-721.	30	8.6007	-742.
15	0.0080	-753.	31	11.1995	-740.
16	0.0085	-785.	32	14.7932	-738.
			33	17.5067	-736.
			34	21.9163	-740.
			35	27.5385	-747.
			36	34.2924	-756.
			37	46.1974	-747.
			38	50.2135	-745.

Specimen No. 4 - Step No. 6 - Initial Time = 235.859 Hours

STEP RESPONSE			RELAXATION			
	TIME (Hrs)	Ø STRAIN (Micro)		TIME (Hrs)	Ø STRAIN (Micro)	
	1	0.0006	1449.	21	0.0119	2419.
	2	0.0008	1489.	22	0.0538	2385.
	3	0.0013	1556.	23	0.2488	2402.
	4	0.0016	1607.	24	0.7102	2387.
	5	0.0021	1662.	25	2.2325	2371.
	6	0.0027	1729.	26	4.9959	2387.
	7	0.0032	1796.	27	5.7633	2381.
	8	0.0035	1861.	28	7.2866	2377.
	9	0.0041	1912.	29	8.8658	2378.
	10	0.0046	1964.	30	15.0647	2367.
	11	0.0049	2030.	31	22.5499	2373.
	12	0.0052	2064.	32	27.2436	2378.
	13	0.0058	2149.	33	38.4920	2386.
	14	0.0063	2199.	34	42.4738	2388.
	15	0.0066	2233.			
	16	0.0072	2284.			
	17	0.0074	2335.			
	18	0.0077	2369.			
	19	0.0083	2417.			
	20	0.0085	2470.			

Specimen No. 4 - Step No. 6 - Initial Time = 235.859 Hours

STEP RESPONSE			RELAXATION			
	TIME (Hrs)	STRESS (Ksi)		TIME (Hrs)	STRESS (Ksi)	
	1	0.0006	2.770	21	0.0119	5.158
	2	0.0008	2.882	22	0.0538	5.049
	3	0.0013	3.038	23	0.2488	4.977
	4	0.0016	3.126	24	0.7102	4.913
	5	0.0021	3.327	25	2.2325	4.888
	6	0.0027	3.528	26	4.9959	4.848
	7	0.0032	3.685	27	5.7633	4.850
	8	0.0035	3.774	28	7.2866	4.842
	9	0.0041	3.930	29	8.8658	4.835
	10	0.0046	4.109	30	15.0647	4.812
	11	0.0049	4.198	31	22.5499	4.765
	12	0.0052	4.290	32	27.2436	4.749
	13	0.0058	4.466	33	38.4920	4.719
	14	0.0063	4.625	34	42.4738	4.708
	15	0.0066	4.734			
	16	0.0072	4.893			
	17	0.0074	4.960			
	18	0.0077	5.047			
	19	0.0083	5.203			
	20	0.0085	5.292			

Specimen No. 4 - Step No. 6 - Initial Time = 235.859 Hours

STEP RESPONSE

RELAXATION

STEP RESPONSE			RELAXATION		
	TIME (Hrs)	90 STRAIN (Micro)		TIME (Hrs)	90 STRAIN (Micro)
1	0.0006	-824.	21	0.0119	-1426.
2	0.0008	-833.	22	0.0538	-1426.
3	0.0013	-865.	23	0.2488	-1399.
4	0.0016	-897.	24	0.7102	-1410.
5	0.0021	-938.	25	2.2325	-1418.
6	0.0027	-970.	26	4.9959	-1437.
7	0.0032	-1026.	27	5.7633	-1412.
8	0.0035	-1042.	28	7.2866	-1412.
9	0.0041	-1106.	29	8.8658	-1413.
10	0.0046	-1154.	30	15.0647	-1426.
11	0.0049	-1170.	31	22.5499	-1432.
12	0.0052	-1202.	32	27.2436	-1426.
13	0.0058	-1234.	33	38.4920	-1423.
14	0.0063	-1298.	34	42.4738	-1424.
15	0.0066	-1288.			
16	0.0072	-1362.			
17	0.0074	-1362.			
18	0.0077	-1394.			
19	0.0083	-1426.			
20	0.0085	-1447.			

Specimen No. 4 - Step No. 7 - Initial Time = 280.524 Hours

STEP RESPONSE			RELAXATION		
	TIME (Hrs)	Ø STRAIN (Micro)		TIME (Hrs)	Ø STRAIN (Micro)
1	0.0004	2470.	22	0.0131	3666.
2	0.0009	2538.	23	0.1345	3672.
3	0.0012	2609.	24	0.2959	3604.
4	0.0015	2619.	25	0.4626	3601.
5	0.0018	2673.	26	0.6101	3611.
6	0.0020	2699.	27	0.7370	3620.
7	0.0023	2801.	28	0.9403	3610.
8	0.0026	2808.	29	1.0802	3620.
9	0.0032	2893.	30	1.4169	3616.
10	0.0037	2955.	31	1.6406	3621.
11	0.0043	3039.	32	2.3408	3610.
12	0.0049	3139.	33	2.7452	3615.
13	0.0054	3214.	34	3.4976	3613.
14	0.0057	3265.	35	4.4360	3625.
15	0.0060	3325.	36	5.1069	3627.
16	0.0065	3384.	37	7.5565	3628.
17	0.0068	3417.	38	8.9685	3623.
18	0.0071	3485.	39	11.6885	3615.
19	0.0076	3536.	40	14.6363	3611.
20	0.0079	3604.	41	17.2653	3610.
21	0.0085	3643.	42	23.3340	3609.
			43	27.0474	3611.
			44	38.0539	3622.
			45	43.8521	3627.

Specimen No. 4 - Step No. 7 - Initial Time = 280.524 Hours

STEP RESPONSE			RELAXATION		
	TIME (Hrs)	STRESS (Ksi)		TIME (Hrs)	STRESS (Ksi)
1	0.0004	4.893	22	0.0131	7.663
2	0.0009	5.139	23	0.1345	7.440
3	0.0012	5.248	24	0.2959	7.436
4	0.0015	5.337	25	0.4626	7.371
5	0.0018	5.451	26	0.6101	7.361
6	0.0020	5.560	27	0.7370	7.348
7	0.0023	5.672	28	0.9403	7.328
8	0.0026	5.761	29	1.0802	7.318
9	0.0032	5.985	30	1.4169	7.302
10	0.0037	6.208	31	1.6406	7.295
11	0.0043	6.387	32	2.3408	7.276
12	0.0049	6.610	33	2.7452	7.263
13	0.0054	6.788	34	3.4976	7.244
14	0.0057	6.904	35	4.4360	7.226
15	0.0060	6.989	36	5.1069	7.218
16	0.0065	7.168	37	7.5565	7.191
17	0.0068	7.283	38	8.9685	7.178
18	0.0071	7.369	39	11.6885	7.145
19	0.0076	7.570	40	14.6363	7.110
20	0.0079	7.663	41	17.2653	7.088
21	0.0085	7.834	42	23.3340	7.048
			43	27.0474	7.032
			44	38.0539	6.998
			45	43.8521	6.980



Specimen No. 4 - Step No. 7 - Initial Time = 280.524 Hours

STEP RESPONSE			RELAXATION		
	TIME (Hrs)	90 STRAIN (Micro)		TIME (Hrs)	90 STRAIN (Micro)
1	0.0004	-1474.	22	0.0131	-2261.
2	0.0009	-1550.	23	0.1345	-2277.
3	0.0012	-1554.	24	0.2959	-2178.
4	0.0015	-1586.	25	0.4626	-2235.
5	0.0018	-1618.	26	0.6101	-2232.
6	0.0020	-1634.	27	0.7370	-2233.
7	0.0023	-1666.	28	0.9403	-2233.
8	0.0026	-1712.	29	1.0802	-2239.
9	0.0032	-1731.	30	1.4169	-2246.
10	0.0037	-1795.	31	1.6406	-2250.
11	0.0043	-1843.	32	2.3408	-2257.
12	0.0049	-1891.	33	2.7452	-2258.
13	0.0054	-1971.	34	3.4976	-2260.
14	0.0057	-2019.	35	4.4360	-2266.
15	0.0060	-2035.	36	5.1069	-2266.
16	0.0065	-2083.	37	7.5565	-2262.
17	0.0068	-2115.	38	8.9685	-2260.
18	0.0071	-2115.	39	11.6885	-2261.
19	0.0076	-2179.	40	14.6363	-2262.
20	0.0079	-2211.	41	17.2653	-2265.
21	0.0085	-2259.	42	23.3340	-2275.
			43	27.0474	-2281.
			44	38.0539	-2283.
			45	43.8521	-2284.

Specimen No. 4 - Step No. 8 - Initial Time = 327.828 Hours

STEP RESPONSE			RELAXATION		
	TIME (Hrs)	Ø STRAIN (Micro)		TIME (Hrs)	Ø STRAIN (Micro)
1	0.0006	3671.	21	0.0712	4945.
2	0.0009	3722.	22	0.3040	4970.
3	0.0015	3794.	23	0.3800	4942.
4	0.0020	3987.	24	0.4293	4932.
5	0.0023	3928.	25	0.5649	4930.
6	0.0026	4010.	26	0.6998	4957.
7	0.0032	4126.	27	1.1456	4963.
8	0.0034	4145.	28	2.3161	4957.
9	0.0040	4230.	29	2.6628	4962.
10	0.0043	4280.	30	3.5945	4965.
11	0.0045	4331.	31	4.3243	4964.
12	0.0048	4382.	32	7.1779	4967.
13	0.0054	4466.	33	9.0141	4969.
14	0.0057	4517.	34	11.8883	4990.
15	0.0062	4602.	35	12.8856	4999.
16	0.0068	4686.	36	18.2744	4985.
17	0.0070	4774.	37	23.8734	4960.
18	0.0076	4859.	38	28.0469	4963.
19	0.0082	4923.	39	37.0553	4968.
20	0.0084	4979.	40	41.4390	4968.
			41	56.2681	4969.
			42	72.0370	4966.

Specimen No. 4 - Step No. 8 - Initial Time = 327.828 Hours

STEP RESPONSE			RELAXATION		
	TIME (Hrs)	STRESS (Ksi)		TIME (Hrs)	STRESS (Ksi)
1	0.0006	7.168	21	0.0712	9.897
2	0.0009	7.302	22	0.3040	9.765
3	0.0015	7.592	23	0.3800	9.746
4	0.0020	7.816	24	0.4293	9.737
5	0.0023	7.923	25	0.5649	9.707
6	0.0026	8.039	26	0.6998	9.685
7	0.0032	8.262	27	1.1456	9.631
8	0.0034	8.352	28	2.3161	9.542
9	0.0040	8.575	29	2.6628	9.535
10	0.0043	8.682	30	3.5945	9.509
11	0.0045	8.821	31	4.3243	9.488
12	0.0048	8.910	32	7.1779	9.420
13	0.0054	9.133	33	9.0141	9.384
14	0.0057	9.245	34	11.8883	9.334
15	0.0062	9.441	35	12.8856	9.326
16	0.0068	9.624	36	18.2744	9.279
17	0.0070	9.736	37	23.8734	9.240
18	0.0076	9.915	38	28.0469	9.217
19	0.0082	10.138	39	37.0553	9.173
20	0.0084	10.250	40	41.4390	9.158
			41	56.2681	9.113
			42	72.0370	9.080

Specimen No. 4 - Step No. 8 - Initial Time = 327.828 Hours

STEP RESPONSE			RELAXATION		
	TIME (Hrs)	90 STRAIN (Micro)		TIME (Hrs)	90 STRAIN (Micro)
1	0.0006	-2323.	21	0.0712	-3198.
2	0.0009	-2355.	22	0.3040	-3176.
3	0.0015	-2420.	23	0.3800	-3182.
4	0.0020	-2468.	24	0.4293	-3181.
5	0.0023	-2516.	25	0.5649	-3172.
6	0.0026	-2532.	26	0.6998	-3170.
7	0.0032	-2616.	27	1.1456	-3197.
8	0.0034	-2628.	28	2.3161	-3211.
9	0.0040	-2676.	29	2.6628	-3200.
10	0.0043	-2708.	30	3.5945	-3198.
11	0.0045	-2719.	31	4.3243	-3208.
12	0.0048	-2750.	32	7.1779	-3221.
13	0.0054	-2836.	33	9.0141	-3219.
14	0.0057	-2852.	34	11.8883	-3242.
15	0.0062	-2916.	35	12.8856	-3248.
16	0.0068	-2980.	36	18.2744	-3252.
17	0.0070	-3012.	37	23.8734	-3243.
18	0.0076	-3061.	38	28.0469	-3246.
19	0.0082	-3166.	39	37.0553	-3249.
20	0.0084	-3198.	40	41.4390	-3252.
			41	56.2681	-3260.
			42	72.0370	-3263.

Specimen No. 4 - Step No. 9 - Initial Time = 406.564 Hours

STEP RESPONSE			RELAXATION			
	TIME (Hrs)	Ø STRAIN (Micro)		TIME (Hrs)	Ø STRAIN (Micro)	
	1	0.0003	5064.	23	0.0305	6411.
	2	0.0006	5132.	24	0.1036	6360.
	3	0.0011	5194.	25	0.2364	6361.
	4	0.0014	5327.	26	0.5869	6402.
	5	0.0017	5354.	27	0.6964	6397.
	6	0.0020	5346.	28	0.8575	6394.
	7	0.0023	5482.	29	1.1337	6381.
	8	0.0028	5482.	30	1.4318	6383.
	9	0.0031	5532.	31	1.7616	6398.
	10	0.0036	5651.	32	2.4506	6444.
	11	0.0039	5641.	33	2.6094	6407.
	12	0.0042	5780.	34	7.0632	6402.
	13	0.0048	5837.	35	8.8688	6421.
	14	0.0050	5899.	36	11.7124	6424.
	15	0.0056	5972.	37	15.4065	6425.
	16	0.0061	6104.	38	16.0851	6447.
	17	0.0064	6155.	39	22.7921	6447.
	18	0.0070	6192.	40	26.1502	6433.
	19	0.0073	6309.	41	39.9051	6419.
	20	0.0078	6361.			
	21	0.0081	6395.			
	22	0.0084	6395.			

Specimen No. 4 - Step No. 9 - Initial Time = 406.564 Hours

STEP RESPONSE			RELAXATION			
	TIME (Hrs)	STRESS (Ksi)		TIME (Hrs)	STRESS (Ks)	
	1	0.0003	9.262	23	0.0305	12.209
	2	0.0006	9.423	24	0.1036	12.014
	3	0.0011	9.691	25	0.2364	11.935
	4	0.0014	9.825	26	0.5869	11.811
	5	0.0017	9.959	27	0.6964	11.794
	6	0.0020	10.049	28	0.8575	11.768
	7	0.0023	10.155	29	1.1337	11.729
	8	0.0028	10.384	30	1.4318	11.696
	9	0.0031	10.557	31	1.7616	11.659
	10	0.0036	10.758	32	2.4506	11.573
	11	0.0039	10.869	33	2.6094	11.590
	12	0.0042	11.003	34	7.0632	11.411
	13	0.0048	11.204	35	8.8688	11.367
	14	0.0050	11.322	36	11.7124	11.318
	15	0.0056	11.517	37	15.4065	11.259
	16	0.0061	11.740	38	16.0851	11.247
	17	0.0064	11.829	39	22.7921	11.199
	18	0.0070	12.075	40	26.1502	11.197
	19	0.0073	12.148	41	39.9051	11.062
	20	0.0078	12.365			
	21	0.0081	12.476			
	22	0.0084	12.387			

Specimen No. 4 - Step No. 9 - Initial Time = 406.564 Hours

STEP RESPONSE

RELAXATION

	TIME (Hrs)	90 STRAIN (Micro)		TIME (Hrs)	90 STRAIN (Micro)
1	0.0003	-3317.	23	0.0305	-4134.
2	0.0006	-3365.	24	0.1036	-4232.
3	0.0011	-3429.	25	0.2364	-4102.
4	0.0014	-3461.	26	0.5869	-4209.
5	0.0017	-3493.	27	0.6964	-4204.
6	0.0020	-3498.	28	0.8575	-4198.
7	0.0023	-3541.	29	1.1337	-4204.
8	0.0028	-3621.	30	1.4318	-4211.
9	0.0031	-3637.	31	1.7616	-4224.
10	0.0036	-3701.	32	2.4506	-4264.
11	0.0039	-3720.	33	2.6094	-4236.
12	0.0042	-3736.	34	7.0632	-4263.
13	0.0048	-3830.	35	8.8688	-4263.
14	0.0050	-3832.	36	11.7124	-4261.
15	0.0056	-3926.	37	15.4065	-4280.
16	0.0061	-3990.	38	16.0851	-4276.
17	0.0064	-4022.	39	22.7921	-4282.
18	0.0070	-4070.	40	26.1502	-4288.
19	0.0073	-4118.	41	39.9051	-4335.
20	0.0078	-4166.			
21	0.0081	-4165.			
22	0.0084	-4198.			

Specimen No. 5 - Step No. 1 - Initial Time = 0 Hours

STEP RESPONSE			RELAXATION		
	TIME (Hrs)	STRESS (Ksi)		TIME (Hrs)	STRESS (Ksi)
1	0.0007	0.166	67	0.0458	11.897
2	0.0013	0.394	68	0.0560	11.701
3	0.0018	0.694	69	0.0658	11.561
4	0.0024	0.973	70	0.0821	11.472
5	0.0032	1.336	71	0.1013	11.416
6	0.0040	1.688	72	0.1267	11.333
7	0.0045	1.905	73	0.1800	11.250
8	0.0051	2.122	74	0.2473	11.167
9	0.0056	2.309	75	0.3684	11.105
10	0.0063	2.495	76	0.4911	11.073
11	0.0071	2.733	77	0.5428	11.022
12	0.0081	2.961	78	0.7867	10.945
13	0.0090	3.191	79	1.0648	10.918
14	0.0097	3.366	80	1.3428	10.877
15	0.0104	3.501	81	1.7600	10.825
16	0.0111	3.666	82	2.3163	10.769
17	0.0117	3.760	83	2.8739	10.727
18	0.0122	3.903	84	3.5691	10.686
19	0.0131	4.090	85	4.5427	10.642
20	0.0137	4.256	86	5.5170	10.602
21	0.0143	4.412	87	6.6467	10.563
22	0.0149	4.546	88	8.8719	10.495
23	0.0157	4.765	89	11.3728	10.443
24	0.0167	4.981	90	14.1228	10.402
25	0.0177	5.221	91	17.8182	10.356
26	0.0184	5.416	92	22.4041	10.313
27	0.0189	5.542	93	28.2419	10.283
28	0.0195	5.675	94	35.7480	10.245
29	0.0201	5.832	95	46.0810	10.180
30	0.0210	6.050	96	50.9354	10.131
31	0.0217	6.215			
32	0.0222	6.360			
33	0.0228	6.516			
34	0.0233	6.671			
35	0.0240	6.858			
36	0.0246	7.054			
37	0.0252	7.229			
38	0.0257	7.415			
39	0.0263	7.572			
40	0.0269	7.767			
41	0.0276	7.972			
42	0.0281	8.130			
43	0.0287	8.308			
44	0.0292	8.492			
45	0.0299	8.687			

Specimen No. 5 - Step No. 1 - Initial Time = 0 Hours

STEP RESPONSE			RELAXATION		
	TIME (Hrs)	Ø STRAIN (Micro)		TIME (Hrs)	Ø STRAIN (Micro)
1	0.0007	149.	67	0.0458	5081.
2	0.0013	239.	68	0.0560	5053.
3	0.0018	339.	69	0.0658	5033.
4	0.0024	440.	70	0.0821	5007.
5	0.0032	571.	71	0.1013	5023.
6	0.0040	705.	72	0.1267	5023.
7	0.0045	778.	73	0.1800	5012.
8	0.0051	852.	74	0.2473	5012.
9	0.0056	915.	75	0.3684	5028.
10	0.0063	992.	76	0.4911	5007.
11	0.0071	1077.	77	0.5428	5001.
12	0.0081	1156.	78	0.7867	5039.
13	0.0090	1246.	79	1.0648	4996.
14	0.0097	1301.	80	1.3428	5012.
15	0.0104	1363.	81	1.7600	5012.
16	0.0111	1411.	82	2.3163	5010.
17	0.0117	1453.	83	2.8739	5009.
18	0.0122	1501.	84	3.5691	5011.
19	0.0131	1570.	85	4.5427	5011.
20	0.0137	1634.	86	5.5170	5014.
21	0.0143	1702.	87	6.6467	5011.
22	0.0149	1745.	88	8.8719	5015.
23	0.0157	1835.	89	11.3728	5015.
24	0.0167	1909.	90	14.1228	5011.
25	0.0177	2015.	91	17.8182	5008.
26	0.0184	2084.	92	22.4041	5007.
27	0.0189	2137.	93	28.2419	5014.
28	0.0195	2190.	94	35.7480	5016.
29	0.0201	2254.	95	46.0810	5012.
30	0.0210	2345.	96	50.9354	5017.
31	0.0217	2413.			
32	0.0222	2466.			
33	0.0228	2530.			
34	0.0233	2606.			
35	0.0240	2673.			
36	0.0246	2753.			
37	0.0252	2812.			
38	0.0257	2886.			
39	0.0263	2954.			
40	0.0269	3044.			
41	0.0276	3123.			
42	0.0281	3206.			
43	0.0287	3288.			
44	0.0292	3345.			
45	0.0299	3436.			

Specimen No. 5 - Step No. 1 - Initial Time = 0 Hours

STEP RESPONSE			RELAXATION		
	TIME (Hrs)	90 STRAIN (Micro)		TIME (Hrs)	90 STRAIN (Micro)
1	0.0007	-26.	67	0.0458	-3886.
2	0.0013	-77.	68	0.0560	-3878.
3	0.0018	-149.	69	0.0658	-3875.
4	0.0024	-227.	70	0.0821	-3875.
5	0.0032	-320.	71	0.1013	-3875.
6	0.0040	-411.	72	0.1267	-3875.
7	0.0045	-477.	73	0.1800	-3896.
8	0.0051	-528.	74	0.2473	-3916.
9	0.0056	-586.	75	0.3684	-3927.
10	0.0063	-648.	76	0.4911	-3866.
11	0.0071	-716.	77	0.5428	-3937.
12	0.0081	-794.	78	0.7867	-3937.
13	0.0090	-861.	79	1.0648	-3896.
14	0.0097	-912.	80	1.3428	-3927.
15	0.0104	-959.	81	1.7600	-3932.
16	0.0111	-1000.	82	2.3163	-3937.
17	0.0117	-1039.	83	2.8739	-3941.
18	0.0122	-1061.	84	3.5691	-3945.
19	0.0131	-1129.	85	4.5427	-3950.
20	0.0137	-1178.	86	5.5170	-3960.
21	0.0143	-1213.	87	6.6467	-3970.
22	0.0149	-1268.	88	8.8719	-3980.
23	0.0157	-1333.	89	11.3728	-3979.
24	0.0167	-1391.	90	14.1228	-3979.
25	0.0177	-1469.	91	17.8182	-3987.
26	0.0184	-1515.	92	22.4041	-3995.
27	0.0189	-1571.	93	28.2419	-4005.
28	0.0195	-1607.	94	35.7480	-4014.
29	0.0201	-1659.	95	46.0810	-4026.
30	0.0210	-1711.	96	50.9354	-4041.
31	0.0217	-1768.			
32	0.0222	-1819.			
33	0.0228	-1855.			
34	0.0233	-1907.			
35	0.0240	-1963.			
36	0.0246	-2015.			
37	0.0252	-2077.			
38	0.0257	-2123.			
39	0.0263	-2180.			
40	0.0269	-2225.			
41	0.0276	-2314.			
42	0.0281	-2354.			
43	0.0287	-2417.			
44	0.0292	-2479.			
45	0.0299	-2538.			



Specimen No. 5 - Step No. 1 - Initial Time = 0 Hours

STEP RESPONSE			RELAXATION		
	TIME (Hrs)	45 STRAIN (Micro)		TIME (Hrs)	45 STRAIN (Micro)
1	0.0007	73.	67	0.0458	610.
2	0.0013	89.	68	0.0560	600.
3	0.0018	105.	69	0.0658	591.
4	0.0024	121.	70	0.0821	591.
5	0.0032	141.	71	0.1013	584.
6	0.0040	162.	72	0.1267	581.
7	0.0045	172.	73	0.1800	584.
8	0.0051	188.	74	0.2473	574.
9	0.0056	193.	75	0.3684	563.
10	0.0063	193.	76	0.4911	578.
11	0.0071	210.	77	0.5428	563.
12	0.0081	220.	78	0.7867	563.
13	0.0090	225.	79	1.0648	571.
14	0.0097	245.	80	1.3428	553.
15	0.0104	246.	81	1.7600	551.
16	0.0111	252.	82	2.3163	549.
17	0.0117	252.	83	2.8739	548.
18	0.0122	260.	84	3.5691	548.
19	0.0131	277.	85	4.5427	547.
20	0.0137	282.	86	5.5170	542.
21	0.0143	292.	87	6.6467	540.
22	0.0149	292.	88	8.8719	534.
23	0.0157	302.	89	11.3728	531.
24	0.0167	308.	90	14.1228	526.
25	0.0177	325.	91	17.8182	521.
26	0.0184	335.	92	22.4041	519.
27	0.0189	342.	93	28.2419	520.
28	0.0195	340.	94	35.7480	517.
29	0.0201	351.	95	46.0810	509.
30	0.0210	366.	96	50.9354	501.
31	0.0217	366.			
32	0.0222	375.			
33	0.0228	382.			
34	0.0233	388.			
35	0.0240	393.			
36	0.0246	407.			
37	0.0252	418.			
38	0.0257	428.			
39	0.0263	432.			
40	0.0269	443.			
41	0.0276	451.			
42	0.0281	468.			
43	0.0287	464.			
44	0.0292	474.			
45	0.0299	485.			

Specimen No. 5 - Step No. 2 - Initial Time = 51.449 Hours

STEP RESPONSE			RELAXATION		
	TIME (Hrs)	Ø STRAIN (Micro)		TIME (Hrs)	Ø STRAIN (Micro)
1	0.0004	5054.	29	0.0107	6405.
2	0.0007	5107.	30	0.0154	6371.
3	0.0010	5149.	31	0.0243	6350.
4	0.0014	5223.	32	0.0352	6384.
5	0.0017	5276.	33	0.0604	6340.
6	0.0019	5318.	34	0.1009	6384.
7	0.0022	5360.	35	0.1814	6373.
8	0.0025	5413.	36	0.2695	6384.
9	0.0028	5437.	37	0.3862	6396.
10	0.0030	5479.	38	0.6170	6407.
11	0.0033	5532.	39	0.9448	6373.
12	0.0036	5584.	40	1.3564	6384.
13	0.0039	5645.	41	1.9314	6394.
14	0.0044	5700.	42	2.9086	6380.
15	0.0047	5782.	43	3.4212	6401.
16	0.0050	5835.	44	4.3161	6418.
17	0.0053	5867.	45	5.6473	6425.
18	0.0055	5888.	46	6.9666	6423.
19	0.0058	5930.	47	8.4899	6422.
20	0.0061	5983.	48	11.2977	6414.
21	0.0064	6057.	49	14.2155	6405.
22	0.0066	6077.	50	18.0400	6399.
23	0.0069	6130.	51	22.6471	6407.
24	0.0074	6225.	52	28.4825	6416.
25	0.0077	6278.	53	35.9852	6419.
26	0.0079	6331.	54	44.7383	6406.
27	0.0082	6384.			
28	0.0085	6382.			

Specimen No. 5 - Step No. 2 - Initial Time = 51.449 Hours

STEP RESPONSE			RELAXATION		
	TIME (Hrs)	STRESS (Ksi)		TIME (Hrs)	STRESS (Ksi)
1	0.0004	10.276	29	0.0107	13.598
2	0.0007	10.421	30	0.0154	13.508
3	0.0010	10.540	31	0.0243	13.425
4	0.0014	10.732	32	0.0352	13.384
5	0.0017	10.856	33	0.0604	13.308
6	0.0019	10.980	34	0.1009	13.246
7	0.0022	11.105	35	0.1814	13.183
8	0.0025	11.229	36	0.2695	13.142
9	0.0028	11.333	37	0.3862	13.059
10	0.0030	11.478	38	0.6170	12.969
11	0.0033	11.596	39	0.9448	12.935
12	0.0036	11.706	40	1.3564	12.852
13	0.0039	11.824	41	1.9314	12.810
14	0.0044	12.052	42	2.9086	12.769
15	0.0047	12.161	43	3.4212	12.744
16	0.0050	12.286	44	4.3161	12.704
17	0.0053	12.396	45	5.6473	12.644
18	0.0055	12.493	46	6.9666	12.583
19	0.0058	12.617	47	8.4899	12.521
20	0.0061	12.742	48	11.2977	12.431
21	0.0064	12.845	49	14.2155	12.366
22	0.0066	12.949	50	18.0400	12.300
23	0.0069	13.073	51	22.6471	12.264
24	0.0074	13.239	52	28.4825	12.211
25	0.0077	13.363	53	35.9852	12.154
26	0.0079	13.467	54	44.7383	12.077
27	0.0082	13.570			
28	0.0085	13.653			

Specimen No. 5 - Step No. 2 - Initial Time = 51.449 Hours

STEP RESPONSE

RELAXATION

STEP RESPONSE			RELAXATION		
	TIME (Hrs)	90 STRAIN (Micro)		TIME (Hrs)	90 STRAIN (Micro)
1	0.0004	-4051.	29	0.0107	-5097.
2	0.0007	-4092.	30	0.0154	-5087.
3	0.0010	-4133.	31	0.0243	-5061.
4	0.0014	-4206.	32	0.0352	-5097.
5	0.0017	-4238.	33	0.0604	-5097.
6	0.0019	-4279.	34	0.1009	-5108.
7	0.0022	-4298.	35	0.1814	-5092.
8	0.0025	-4329.	36	0.2695	-5092.
9	0.0028	-4383.	37	0.3862	-5139.
10	0.0030	-4401.	38	0.6170	-5166.
11	0.0033	-4422.	39	0.9448	-5149.
12	0.0036	-4453.	40	1.3564	-5160.
13	0.0039	-4494.	41	1.9314	-5170.
14	0.0044	-4556.	42	2.9086	-5145.
15	0.0047	-4587.	43	3.4212	-5161.
16	0.0050	-4638.	44	4.3161	-5173.
17	0.0053	-4659.	45	5.6473	-5185.
18	0.0055	-4690.	46	6.9666	-5188.
19	0.0058	-4721.	47	8.4899	-5195.
20	0.0061	-4762.	48	11.2977	-5204.
21	0.0064	-4793.	49	14.2155	-5204.
22	0.0066	-4834.	50	18.0400	-5208.
23	0.0069	-4865.	51	22.6471	-5213.
24	0.0074	-4952.	52	28.4825	-5228.
25	0.0077	-4968.	53	35.9852	-5247.
26	0.0079	-5025.	54	44.7383	-5266.
27	0.0082	-5004.			
28	0.0085	-5050.			

Specimen No. 5 - Step No. 2 - Initial Time = 51.449 Hours

STEP RESPONSE			RELAXATION			
	TIME (Hrs)	45 STRAIN (Micro)		TIME (Hrs)	45 STRAIN (Micro)	
	1	0.0004	511.	29	0.0107	657.
	2	0.0007	521.	30	0.0154	654.
	3	0.0010	529.	31	0.0243	643.
	4	0.0014	532.	32	0.0352	647.
	5	0.0017	532.	33	0.0604	636.
	6	0.0019	542.	34	0.1009	626.
	7	0.0022	553.	35	0.1814	626.
	8	0.0025	553.	36	0.2695	615.
	9	0.0028	563.	37	0.3862	615.
	10	0.0030	571.	38	0.6170	615.
	11	0.0033	578.	39	0.9448	608.
	12	0.0036	581.	40	1.3564	615.
	13	0.0039	581.	41	1.9314	605.
	14	0.0044	602.	42	2.9086	616.
	15	0.0047	602.	43	3.4212	614.
	16	0.0050	602.	44	4.3161	614.
	17	0.0053	605.	45	5.6473	613.
	18	0.0055	615.	46	6.9666	610.
	19	0.0058	622.	47	8.4899	607.
	20	0.0061	633.	48	11.2977	600.
	21	0.0064	633.	49	14.2155	594.
	22	0.0066	643.	50	18.0400	586.
	23	0.0069	654.	51	22.6471	585.
	24	0.0074	647.	52	28.4825	584.
	25	0.0077	654.	53	35.9852	581.
	26	0.0079	657.	54	44.7383	567.
	27	0.0082	664.			
	28	0.0085	678.			

Specimen No. 5 - Step No. 3 - Initial Time = 100.588 Hours

STEP RESPONSE

RELAXATION

	TIME (Hrs)	Ø STRAIN (Micro)		TIME (Hrs)	Ø STRAIN (Micro)
1	0.0000	6458.	30	0.0114	7774.
2	0.0003	6521.	31	0.0156	7798.
3	0.0007	6584.	32	0.0238	7798.
4	0.0010	6602.	33	0.0377	7787.
5	0.0013	6690.	34	0.0563	7746.
6	0.0015	6742.	35	0.0811	7746.
7	0.0018	6795.	36	0.1250	7736.
8	0.0021	6848.	37	0.1680	7777.
9	0.0024	6890.	38	0.2422	7777.
10	0.0026	6932.	39	0.3625	7746.
11	0.0029	6985.	40	0.4463	7763.
12	0.0032	6991.	41	0.5613	7777.
13	0.0038	7133.	42	0.8396	7746.
14	0.0041	7175.	43	1.0810	7757.
15	0.0043	7217.	44	1.5305	7798.
16	0.0046	7260.	45	1.8319	7798.
17	0.0049	7312.	46	2.5013	7808.
18	0.0052	7354.	47	3.1174	7808.
19	0.0055	7436.	48	3.5701	7795.
20	0.0057	7449.	49	4.6072	7789.
21	0.0060	7463.	50	5.5004	7808.
22	0.0063	7515.	51	6.8424	7795.
23	0.0067	7578.	52	9.1019	7778.
24	0.0070	7631.	53	11.5635	7757.
25	0.0073	7673.	54	14.2626	7747.
26	0.0075	7715.	55	17.9423	7739.
27	0.0078	7767.	56	22.5277	7750.
28	0.0081	7799.	57	28.3685	7756.
29	0.0084	7757.	58	35.8711	7761.
			59	43.7947	7754.

Specimen No. 5 - Step No. 3 - Initial Time = 100.588 Hours

STEP RESPONSE			RELAXATION			
	TIME (Hrs)	STRESS (Ksi)		TIME (Hrs)	STRESS (Ksi)	
	1	0.0000	12.141	30	0.0114	15.361
	2	0.0003	12.306	31	0.0156	15.311
	3	0.0007	12.479	32	0.0238	15.235
	4	0.0010	12.617	33	0.0377	15.173
	5	0.0013	12.762	34	0.0563	15.103
	6	0.0015	12.887	35	0.0811	15.070
	7	0.0018	13.017	36	0.1250	15.000
	8	0.0021	13.163	37	0.1680	14.974
	9	0.0024	13.266	38	0.2422	14.911
	10	0.0026	13.391	39	0.3625	14.862
	11	0.0029	13.494	40	0.4463	14.822
	12	0.0032	13.619	41	0.5613	14.745
	13	0.0038	13.860	42	0.8396	14.696
	14	0.0041	13.992	43	1.0810	14.621
	15	0.0043	14.082	44	1.5305	14.565
	16	0.0046	14.178	45	1.8319	14.497
	17	0.0049	14.303	46	2.5013	14.448
	18	0.0052	14.427	47	3.1174	14.372
	19	0.0055	14.551	48	3.5701	14.349
	20	0.0057	14.655	49	4.6072	14.266
	21	0.0060	14.779	50	5.5004	14.199
	22	0.0063	14.896	51	6.8424	14.116
	23	0.0067	15.070	52	9.1019	14.008
	24	0.0070	15.153	53	11.5635	13.914
	25	0.0073	15.256	54	14.2626	13.836
	26	0.0075	15.373	55	17.9423	13.755
	27	0.0078	15.476	56	22.5277	13.696
	28	0.0081	15.567	57	28.3685	13.619
	29	0.0084	15.422	58	35.8711	13.524
				59	43.7947	13.420

Specimen No. 5 - Step No. 3 - Initial Time = 100.588 Hours

STEP RESPONSE

RELAXATION

STEP RESPONSE			RELAXATION		
	TIME (Hrs)	90 STRAIN (Micro)		TIME (Hrs)	90 STRAIN (Micro)
1	0.0000	-5277.	30	0.0114	-6249.
2	0.0003	-5308.	31	0.0156	-6215.
3	0.0007	-5398.	32	0.0238	-6248.
4	0.0010	-5411.	33	0.0377	-6248.
5	0.0013	-5452.	34	0.0563	-6215.
6	0.0015	-5512.	35	0.0811	-6205.
7	0.0018	-5553.	36	0.1250	-6248.
8	0.0021	-5555.	37	0.1680	-6258.
9	0.0024	-5626.	38	0.2422	-6291.
10	0.0026	-5657.	39	0.3625	-6268.
11	0.0029	-5698.	40	0.4463	-6280.
12	0.0032	-5719.	41	0.5613	-6322.
13	0.0038	-5772.	42	0.8396	-6299.
14	0.0041	-5823.	43	1.0810	-6299.
15	0.0043	-5895.	44	1.5305	-6277.
16	0.0046	-5895.	45	1.8319	-6364.
17	0.0049	-5937.	46	2.5013	-6298.
18	0.0052	-5968.	47	3.1174	-6341.
19	0.0055	-6041.	48	3.5701	-6321.
20	0.0057	-6040.	49	4.6072	-6327.
21	0.0060	-6071.	50	5.5004	-6361.
22	0.0063	-6102.	51	6.8424	-6346.
23	0.0067	-6122.	52	9.1019	-6333.
24	0.0070	-6185.	53	11.5635	-6327.
25	0.0073	-6216.	54	14.2626	-6331.
26	0.0075	-6248.	55	17.9423	-6338.
27	0.0078	-6256.	56	22.5277	-6343.
28	0.0081	-6320.	57	28.3685	-6354.
29	0.0084	-6215.	58	35.8711	-6362.
			59	43.7947	-6368.



Specimen No. 5 - Step No. 3 - Initial Time = 100.588 Hours

STEP RESPONSE			RELAXATION		
	TIME (Hrs)	45 STRAIN (Micro)		TIME (Hrs)	45 STRAIN (Micro)
1	0.0000	571.	30	0.0114	737.
2	0.0003	578.	31	0.0156	737.
3	0.0007	594.	32	0.0238	740.
4	0.0010	591.	33	0.0377	737.
5	0.0013	602.	34	0.0563	737.
6	0.0015	602.	35	0.0811	726.
7	0.0018	605.	36	0.1250	726.
8	0.0021	615.	37	0.1680	720.
9	0.0024	626.	38	0.2422	720.
10	0.0026	626.	39	0.3625	726.
11	0.0029	639.	40	0.4463	723.
12	0.0032	643.	41	0.5613	709.
13	0.0038	654.	42	0.8396	716.
14	0.0041	667.	43	1.0810	709.
15	0.0043	657.	44	1.5305	702.
16	0.0046	667.	45	1.8319	699.
17	0.0049	667.	46	2.5013	695.
18	0.0052	674.	47	3.1174	699.
19	0.0055	678.	48	3.5701	700.
20	0.0057	688.	49	4.6072	696.
21	0.0060	709.	50	5.5004	695.
22	0.0063	705.	51	6.8424	691.
23	0.0067	716.	52	9.1019	687.
24	0.0070	716.	53	11.5635	680.
25	0.0073	716.	54	14.2626	675.
26	0.0075	726.	55	17.9423	671.
27	0.0078	726.	56	22.5277	672.
28	0.0081	737.	57	28.3685	671.
29	0.0084	747.	58	35.8711	665.
			59	43.7947	653.

AD-A141 697

MATRIX-DOMINATED TIME-DEPENDENT DEFORMATION AND DAMAGE  
OF GRAPHITE EPOXY. (U) LAWRENCE LIVERMORE NATIONAL LAB  
CA E H MU ET AL. MAY 83 UCID-19765 AFAL-TR-83-3056  
W-7405-ENG-48

5/6

UNCLASSIFIED

F/G 11/9

NL

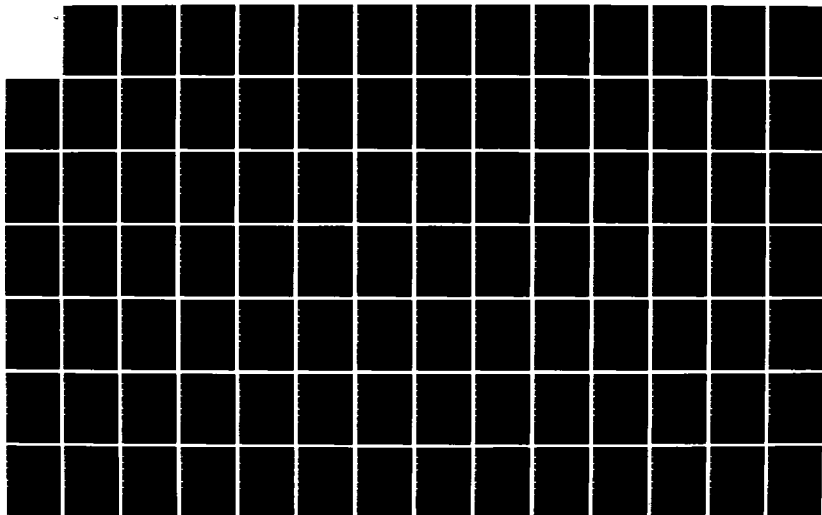

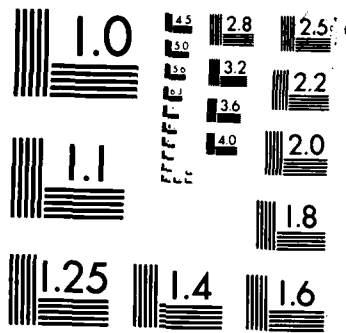

MICROCOPY RESOLUTION TEST CHART  
NATIONAL BUREAU OF STANDARDS-1963-A

Specimen No. 5 - Step No. 4 - Initial Time = 148.224 Hours

STEP RESPONSE			RELAXATION		
	TIME (Hrs)	Ø STRAIN (Micro)		TIME (Hrs)	Ø STRAIN (Micro)
1	0.0006	7778.	15	0.0089	8471.
2	0.0009	7830.	16	0.0330	8505.
3	0.0011	7924.	17	0.1590	8471.
4	0.0014	7935.	18	0.4031	8505.
5	0.0017	7998.	19	0.8401	8471.
6	0.0020	8040.	20	1.5712	8468.
7	0.0025	8135.	21	2.0468	8492.
8	0.0027	8187.	22	2.9007	8498.
9	0.0030	8283.	23	3.8793	8513.
10	0.0033	8292.	24	4.6960	8513.
11	0.0036	8389.	25	5.5296	8479.
12	0.0039	8431.	26	6.7509	8481.
13	0.0041	8395.	27	8.8055	8489.
14	0.0044	8481.	28	11.3063	8492.
			29	14.2241	8494.
			30	17.9769	8490.
			31	22.5635	8497.
			32	28.3996	8498.
			33	35.9023	8503.
			34	45.0075	8506.

Specimen No. 5 - Step No. 4 - Initial Time = 148.224 Hours

STEP RESPONSE			RELAXATION		
	TIME (Hrs)	STRESS (Ksi)		TIME (Hrs)	STRESS (Ksi)
1	0.0006	13.515	15	0.0089	15.235
2	0.0009	13.639	16	0.0330	15.181
3	0.0011	13.784	17	0.1590	15.132
4	0.0014	13.909	18	0.4031	15.057
5	0.0017	14.067	19	0.8401	15.028
6	0.0020	14.199	20	1.5712	15.020
7	0.0025	14.427	21	2.0468	14.945
8	0.0027	14.572	22	2.9007	14.930
9	0.0030	14.696	23	3.8793	14.904
10	0.0033	14.842	24	4.6960	14.821
11	0.0036	14.945	25	5.5296	14.821
12	0.0039	15.070	26	6.7509	14.760
13	0.0041	15.194	27	8.8055	14.669
14	0.0044	15.290	28	11.3063	14.581
			29	14.2241	14.498
			30	17.9769	14.412
			31	22.5635	14.335
			32	28.3996	14.238
			33	35.9023	14.121
			34	45.0075	13.978

Specimen No. 5 - Step No. 4 - Initial Time = 148.224 Hours

STEP RESPONSE			RELAXATION		
	TIME (Hrs)	90 STRAIN (Micro)		TIME (Hrs)	90 STRAIN (Micro)
1	0.0006	-6390.	15	0.0089	-6947.
2	0.0009	-6421.	16	0.0330	-6921.
3	0.0011	-6496.	17	0.1590	-6921.
4	0.0014	-6527.	18	0.4031	-6968.
5	0.0017	-6545.	19	0.8401	-6978.
6	0.0020	-6610.	20	1.5712	-6870.
7	0.0025	-6658.	21	2.0468	-6962.
8	0.0027	-6724.	22	2.9007	-6944.
9	0.0030	-6755.	23	3.8793	-6973.
10	0.0033	-6786.	24	4.6960	-6973.
11	0.0036	-6828.	25	5.5296	-6937.
12	0.0039	-6823.	26	6.7509	-6953.
13	0.0041	-6890.	27	8.8055	-6968.
14	0.0044	-6885.	28	11.3063	-6970.
			29	14.2241	-6971.
			30	17.9769	-6973.
			31	22.5635	-6978.
			32	28.3996	-6976.
			33	35.9023	-6981.
			34	45.0075	-6996.

Specimen No. 5 - Step No. 4 - Initial Time = 148.224 Hours

STEP RESPONSE			RELAXATION		
	TIME (Hrs)	45 STRAIN (Micro)		TIME (Hrs)	45 STRAIN (Micro)
1	0.0006	664.	15	0.0089	747.
2	0.0009	674.	16	0.0330	737.
3	0.0011	664.	17	0.1590	747.
4	0.0014	688.	18	0.4031	730.
5	0.0017	685.	19	0.8401	737.
6	0.0020	695.	20	1.5712	753.
7	0.0025	705.	21	2.0468	740.
8	0.0027	716.	22	2.9007	745.
9	0.0030	716.	23	3.8793	743.
10	0.0033	726.	24	4.6960	737.
11	0.0036	737.	25	5.5296	743.
12	0.0039	737.	26	6.7509	740.
13	0.0041	747.	27	8.8055	733.
14	0.0044	743.	28	11.3063	726.
			29	14.2241	719.
			30	17.9769	713.
			31	22.5635	716.
			32	28.3996	722.
			33	35.9023	722.
			34	45.0075	713.

Specimen No. 5 - Step No. 5 - Initial Time = 197.091 Hours

STEP RESPONSE			RELAXATION		
	TIME (Hrs)	Ø STRAIN (Micro)		TIME (Hrs)	Ø STRAIN (Micro)
1	0.0003	8576.	15	0.0101	9258.
2	0.0006	8628.	16	0.0328	9247.
3	0.0009	8681.	17	0.1126	9237.
4	0.0012	8733.	18	0.2543	9285.
5	0.0015	8796.	19	0.5465	9247.
6	0.0017	8848.	20	0.9706	9296.
7	0.0020	8844.	21	1.4755	9296.
8	0.0026	9032.	22	2.1903	9245.
9	0.0028	9037.	23	2.7197	9258.
10	0.0031	9090.	24	3.4966	9258.
11	0.0034	9084.	25	4.4849	9247.
12	0.0037	9184.	26	5.9308	9237.
13	0.0039	9226.	27	6.7129	9230.
14	0.0042	9268.	28	8.9434	9229.
			29	11.1807	9220.
			30	13.9666	9220.
			31	17.2841	9226.
			32	22.5394	9241.
			33	28.3758	9247.
			34	35.8785	9235.

Specimen No. 5 - Step No. 5 - Initial Time = 197.091 Hours

STEP RESPONSE			RELAXATION		
	TIME (Hrs)	STRESS (Ksi)		TIME (Hrs)	STRESS (Ksi)
1	0.0003	14.158	15	0.0101	15.837
2	0.0006	14.282	16	0.0328	15.762
3	0.0009	14.427	17	0.1126	15.712
4	0.0012	14.565	18	0.2543	15.650
5	0.0015	14.710	19	0.5465	15.617
6	0.0017	14.834	20	0.9706	15.575
7	0.0020	14.966	21	1.4755	15.534
8	0.0026	15.215	22	2.1903	15.485
9	0.0028	15.339	23	2.7197	15.451
10	0.0031	15.456	24	3.4966	15.360
11	0.0034	15.567	25	4.4849	15.320
12	0.0037	15.691	26	5.9308	15.253
13	0.0039	15.795	27	6.7129	15.220
14	0.0042	15.899	28	8.9434	15.126
			29	11.1807	15.046
			30	13.9666	14.963
			31	17.2841	14.894
			32	22.5394	14.822
			33	28.3758	14.738
			34	35.8785	14.622

Specimen No. 5 - Step No. 5 - Initial Time = 197.091 Hours

STEP RESPONSE			RELAXATION		
	TIME (Hrs)	90 STRAIN (Micro)		TIME (Hrs)	90 STRAIN (Micro)
1	0.0003	-7019.	15	0.0101	-7524.
2	0.0006	-7071.	16	0.0328	-7563.
3	0.0009	-7102.	17	0.1126	-7563.
4	0.0012	-7143.	18	0.2543	-7574.
5	0.0015	-7221.	19	0.5465	-7574.
6	0.0017	-7215.	20	0.9706	-7584.
7	0.0020	-7256.	21	1.4755	-7584.
8	0.0026	-7328.	22	2.1903	-7555.
9	0.0028	-7387.	23	2.7197	-7605.
10	0.0031	-7439.	24	3.4966	-7594.
11	0.0034	-7480.	25	4.4849	-7592.
12	0.0037	-7501.	26	5.9308	-7587.
13	0.0039	-7543.	27	6.7129	-7583.
14	0.0042	-7574.	28	8.9434	-7592.
			29	11.1807	-7589.
			30	13.9666	-7598.
			31	17.2841	-7614.
			32	22.5394	-7629.
			33	28.3758	-7645.
			34	35.8785	-7667.

Specimen No. 5 - Step No. 5 - Initial Time = 197.091 Hours

STEP RESPONSE			RELAXATION		
	TIME (Hrs)	45 STRAIN (Micro)		TIME (Hrs)	45 STRAIN (Micro)
1	0.0003	726.	15	0.0101	809.
2	0.0006	737.	16	0.0328	809.
3	0.0009	743.	17	0.1126	799.
4	0.0012	753.	18	0.2543	803.
5	0.0015	757.	19	0.5465	788.
6	0.0017	764.	20	0.9706	788.
7	0.0020	764.	21	1.4755	788.
8	0.0026	778.	22	2.1903	791.
9	0.0028	784.	23	2.7197	788.
10	0.0031	784.	24	3.4966	788.
11	0.0034	788.	25	4.4849	781.
12	0.0037	799.	26	5.9308	778.
13	0.0039	805.	27	6.7129	776.
14	0.0042	799.	28	8.9434	769.
			29	11.1807	762.
			30	13.9666	757.
			31	17.2841	752.
			32	22.5394	749.
			33	28.3758	743.
			34	35.8785	736.

Specimen No. 5 - Step No. 6 - Initial Time = 237.231 Hours

STEP RESPONSE			RELAXATION			
	TIME (Hrs)	Ø STRAIN (Micro)		TIME (Hrs)	Ø STRAIN (Micro)	
	1	0.0001	9279.	16	0.0064	10024.
	2	0.0004	9342.	17	0.0167	10014.
	3	0.0007	9394.	18	0.0639	10003.
	4	0.0010	9496.	19	0.1589	9951.
	5	0.0014	9531.	20	0.3812	9951.
	6	0.0016	9573.	21	0.8198	10003.
	7	0.0019	9625.	22	1.2451	10003.
	8	0.0022	9678.	23	1.9669	9943.
	9	0.0025	9730.	24	1.9957	9951.
	10	0.0028	9772.	25	2.7204	9961.
	11	0.0030	9814.	26	3.3504	9961.
	12	0.0033	9877.	27	4.4870	9956.
	13	0.0036	9919.	28	5.7065	9961.
	14	0.0039	9961.	29	6.9570	9976.
	15	0.0042	9993.	30	9.0410	9997.
				31	11.5230	10006.
				32	14.4406	9990.
				33	18.1919	9974.
				34	22.2552	9967.
				35	28.0868	9970.
				36	35.8780	9976.
				37	45.0878	9976.
				38	50.4193	9972.

Specimen No. 5 - Step No. 6 - Initial Time = 237.231 Hours

STEP RESPONSE			RELAXATION			
	TIME (Hrs)	STRESS (Ksi)		TIME (Hrs)	STRESS (Ksi)	
	1	0.0001	14.738	16	0.0064	16.479
	2	0.0004	14.862	17	0.0167	16.425
	3	0.0007	15.020	18	0.0639	16.334
	4	0.0010	15.153	19	0.1589	16.301
	5	0.0014	15.352	20	0.3812	16.251
	6	0.0016	15.484	21	0.8198	16.189
	7	0.0019	15.629	22	1.2451	16.127
	8	0.0022	15.774	23	1.9669	16.093
	9	0.0025	15.878	24	1.9957	16.085
	10	0.0028	16.002	25	2.7204	16.052
	11	0.0030	16.127	26	3.3504	15.953
	12	0.0033	16.230	27	4.4870	15.922
	13	0.0036	16.355	28	5.7065	15.878
	14	0.0039	16.479	29	6.9570	15.838
	15	0.0042	16.533	30	9.0410	15.781
				31	11.5230	15.701
				32	14.4406	15.601
				33	18.1919	15.470
				34	22.2552	15.364
				35	28.0868	15.268
				36	35.8780	15.164
				37	45.0878	15.049
				38	50.4193	14.989



Specimen No. 5 - Step No. 6 - Initial Time = 237.231 Hours

STEP RESPONSE			RELAXATION		
	TIME (Hrs)	90 STRAIN (Micro)		TIME (Hrs)	90 STRAIN (Micro)
1	0.0001	-7708.	16	0.0064	-8216.
2	0.0004	-7760.	17	0.0167	-8259.
3	0.0007	-7791.	18	0.0639	-8206.
4	0.0010	-7833.	19	0.1589	-8259.
5	0.0014	-7885.	20	0.3812	-8216.
6	0.0016	-7926.	21	0.8198	-8216.
7	0.0019	-7916.	22	1.2451	-8280.
8	0.0022	-7947.	23	1.9669	-8241.
9	0.0025	-8030.	24	1.9957	-8226.
10	0.0028	-8071.	25	2.7204	-8280.
11	0.0030	-8112.	26	3.3504	-8237.
12	0.0033	-8144.	27	4.4870	-8266.
13	0.0036	-8132.	28	5.7065	-8247.
14	0.0039	-8195.	29	6.9570	-8267.
15	0.0042	-8226.	30	9.0410	-8275.
			31	11.5230	-8269.
			32	14.4406	-8261.
			33	18.1919	-8268.
			34	22.2552	-8285.
			35	28.0868	-8304.
			36	35.8780	-8309.
			37	45.0878	-8309.
			38	50.4193	-8308.

Specimen No. 5 - Step No. 6 - Initial Time = 237.231 Hours

STEP RESPONSE			RELAXATION		
	TIME (Hrs)	45 STRAIN (Micro)		TIME (Hrs)	45 STRAIN (Micro)
1	0.0001	737.	16	0.0064	830.
2	0.0004	747.	17	0.0167	824.
3	0.0007	753.	18	0.0639	820.
4	0.0010	768.	19	0.1589	809.
5	0.0014	764.	20	0.3812	809.
6	0.0016	768.	21	0.8198	809.
7	0.0019	788.	22	1.2451	799.
8	0.0022	795.	23	1.9669	803.
9	0.0025	799.	24	1.9957	799.
10	0.0028	809.	25	2.7204	803.
11	0.0030	809.	26	3.3504	799.
12	0.0033	820.	27	4.4870	795.
13	0.0036	815.	28	5.7065	805.
14	0.0039	830.	29	6.9570	804.
15	0.0042	826.	30	9.0410	803.
			31	11.5230	800.
			32	14.4406	795.
			33	18.1919	785.
			34	22.2552	777.
			35	28.0868	770.
			36	35.8780	766.
			37	45.0878	761.
			38	50.4193	757.

Specimen No. 5 - Step No. 7 - Initial Time = 288.177 Hours

STEP RESPONSE			RELAXATION		
	TIME (Hrs)	Ø STRAIN (Micro)		TIME (Hrs)	Ø STRAIN (Micro)
1	0.0006	10045.	15	0.0087	10748.
2	0.0009	10108.	16	0.0317	10738.
3	0.0011	10161.	17	0.1184	10784.
4	0.0014	10213.	18	0.3062	10671.
5	0.0019	10362.	19	0.5134	10717.
6	0.0022	10360.	20	0.9631	10696.
7	0.0024	10348.	21	1.0353	10706.
8	0.0027	10454.	22	1.6473	10685.
9	0.0030	10517.	23	2.4095	10706.
10	0.0033	10504.	24	3.5466	10696.
11	0.0035	10567.	25	4.6860	10706.
12	0.0038	10619.	26	5.5211	10661.
13	0.0041	10717.	27	6.7715	10667.
14	0.0044	10713.	28	9.1676	10666.
			29	11.5188	10675.
			30	14.3651	10676.
			31	18.2092	10680.
			32	22.7966	10682.
			33	28.6340	10690.
			34	35.7205	10691.
			35	44.0568	10681.

Specimen No. 5 - Step No. 7 - Initial Time = 288.177 Hours

STEP RESPONSE			RELAXATION		
	TIME (Hrs)	STRESS (Ksi)		TIME (Hrs)	STRESS (Ksi)
1	0.0006	15.186	15	0.0087	16.935
2	0.0009	15.339	16	0.0317	16.852
3	0.0011	15.484	17	0.1184	16.799
4	0.0014	15.609	18	0.3062	16.757
5	0.0019	15.837	19	0.5134	16.666
6	0.0022	15.982	20	0.9631	16.604
7	0.0024	16.114	21	1.0353	16.624
8	0.0027	16.251	22	1.6473	16.591
9	0.0030	16.376	23	2.4095	16.521
10	0.0033	16.500	24	3.5466	16.482
11	0.0035	16.645	25	4.6860	16.425
12	0.0038	16.761	26	5.5211	16.425
13	0.0041	16.906	27	6.7715	16.369
14	0.0044	16.997	28	9.1676	16.283
			29	11.5188	16.200
			30	14.3651	16.103
			31	18.2092	16.002
			32	22.7966	15.927
			33	28.6340	15.841
			34	35.7205	15.735
			35	44.0568	15.590

Specimen No. 5 - Step No. 7 - Initial Time = 288.177 Hours

STEP RESPONSE			RELAXATION		
	TIME (Hrs)	90 STRAIN (Micro)		TIME (Hrs)	90 STRAIN (Micro)
1	0.0006	-8382.	15	0.0087	-8889.
2	0.0009	-8423.	16	0.0317	-8936.
3	0.0011	-8465.	17	0.1184	-8879.
4	0.0014	-8506.	18	0.3062	-8889.
5	0.0019	-8568.	19	0.5134	-8879.
6	0.0022	-8610.	20	0.9631	-8869.
7	0.0024	-8651.	21	1.0353	-8869.
8	0.0027	-8682.	22	1.6473	-8879.
9	0.0030	-8668.	23	2.4095	-8889.
10	0.0033	-8755.	24	3.5466	-8861.
11	0.0035	-8740.	25	4.6860	-8900.
12	0.0038	-8771.	26	5.5211	-8910.
13	0.0041	-8802.	27	6.7715	-8910.
14	0.0044	-8843.	28	9.1676	-8905.
			29	11.5188	-8907.
			30	14.3651	-8929.
			31	18.2092	-8935.
			32	22.7966	-8948.
			33	28.6340	-8948.
			34	35.7205	-8950.
			35	44.0568	-8931.

Specimen No. 5 - Step No. 7 - Initial Time = 288.177 Hours

STEP RESPONSE			RELAXATION		
	TIME (Hrs)	45 STRAIN (Micro)		TIME (Hrs)	45 STRAIN (Micro)
1	0.0006	764.	15	0.0087	846.
2	0.0009	778.	16	0.0317	851.
3	0.0011	784.	17	0.1184	840.
4	0.0014	784.	18	0.3062	840.
5	0.0019	799.	19	0.5134	840.
6	0.0022	805.	20	0.9631	799.
7	0.0024	805.	21	1.0353	815.
8	0.0027	815.	22	1.6473	799.
9	0.0030	826.	23	2.4095	805.
10	0.0033	836.	24	3.5466	795.
11	0.0035	846.	25	4.6860	784.
12	0.0038	846.	26	5.5211	795.
13	0.0041	852.	27	6.7715	795.
14	0.0044	857.	28	9.1676	792.
			29	11.5188	786.
			30	14.3651	779.
			31	18.2092	766.
			32	22.7966	758.
			33	28.6340	752.
			34	35.7205	752.
			35	44.0568	755.

Specimen No. 5 - Step No. 8 - Initial Time = 336.492 Hours

STEP RESPONSE			RELAXATION		
	TIME (Hrs)	Ø STRAIN (Micro)		TIME (Hrs)	Ø STRAIN (Micro)
1	0.0002	10703.	16	0.0076	11434.
2	0.0005	10755.	17	0.0169	11483.
3	0.0008	10864.	18	0.0640	11413.
4	0.0010	10814.	19	0.1576	11462.
5	0.0013	10912.	20	0.3457	11462.
6	0.0016	11021.	21	0.6393	11462.
7	0.0019	11016.	22	1.0532	11402.
8	0.0024	11158.	23	1.6554	11413.
9	0.0026	11210.	24	2.2130	11473.
10	0.0029	11194.	25	2.9830	11533.
11	0.0032	11256.	26	3.8534	11466.
12	0.0035	11298.	27	4.3458	11446.
13	0.0037	11350.	28	5.8765	11481.
14	0.0040	11402.	29	7.5224	11470.
15	0.0043	11385.	30	9.1896	11466.
			31	11.2139	11439.
			32	14.1317	11434.
			33	17.8829	11430.
			34	22.4689	11425.
			35	28.4840	11434.
			36	35.9879	11436.
			37	43.8624	11428.

Specimen No. 5 - Step No. 8 - Initial Time = 336.492 Hours

STEP RESPONSE			RELAXATION		
	TIME (Hrs)	STRESS (Ksi)		TIME (Hrs)	STRESS (Ksi)
1	0.0002	15.663	16	0.0076	17.545
2	0.0005	15.808	17	0.0169	17.453
3	0.0008	15.932	18	0.0640	17.412
4	0.0010	16.077	19	0.1576	17.350
5	0.0013	16.230	20	0.3457	17.296
6	0.0016	16.367	21	0.6393	17.246
7	0.0019	16.471	22	1.0532	17.163
8	0.0024	16.707	23	1.6554	17.142
9	0.0026	16.832	24	2.2130	17.072
10	0.0029	16.947	25	2.9830	17.018
11	0.0032	17.092	26	3.8534	16.974
12	0.0035	17.225	27	4.3458	16.944
13	0.0037	17.341	28	5.8765	16.855
14	0.0040	17.474	29	7.5224	16.774
15	0.0043	17.589	30	9.1896	16.690
			31	11.2139	16.598
			32	14.1317	16.486
			33	17.8829	16.383
			34	22.4689	16.285
			35	28.4840	16.174
			36	35.9879	16.041
			37	43.8624	15.899

Specimen No. 5 - Step No. 8 - Initial Time = 336.492 Hours

STEP RESPONSE			RELAXATION		
	TIME (Hrs)	90 STRAIN (Micro)		TIME (Hrs)	90 STRAIN (Micro)
1	0.0002	-8947.	16	0.0076	-9532.
2	0.0005	-8977.	17	0.0169	-9582.
3	0.0008	-9029.	18	0.0640	-9522.
4	0.0010	-9060.	19	0.1576	-9522.
5	0.0013	-9111.	20	0.3457	-9582.
6	0.0016	-9190.	21	0.6393	-9532.
7	0.0019	-9221.	22	1.0532	-9532.
8	0.0024	-9294.	23	1.6554	-9542.
9	0.0026	-9325.	24	2.2130	-9542.
10	0.0029	-9356.	25	2.9830	-9553.
11	0.0032	-9338.	26	3.8534	-9547.
12	0.0035	-9379.	27	4.3458	-9545.
13	0.0037	-9421.	28	5.8765	-9555.
14	0.0040	-9452.	29	7.5224	-9550.
15	0.0043	-9482.	30	9.1896	-9562.
			31	11.2139	-9557.
			32	14.1317	-9561.
			33	17.8829	-9564.
			34	22.4689	-9575.
			35	28.4840	-9592.
			36	35.9879	-9595.
			37	43.8624	-9587.

Specimen No. 5 - Step No. 8 - Initial Time = 336.492 Hours

STEP RESPONSE			RELAXATION		
	TIME (Hrs)	45 STRAIN (Micro)		TIME (Hrs)	45 STRAIN (Micro)
1	0.0002	760.	16	0.0076	857.
2	0.0005	770.	17	0.0169	846.
3	0.0008	784.	18	0.0640	846.
4	0.0010	780.	19	0.1576	836.
5	0.0013	790.	20	0.3457	851.
6	0.0016	795.	21	0.6393	840.
7	0.0019	805.	22	1.0532	836.
8	0.0024	805.	23	1.6554	836.
9	0.0026	815.	24	2.2130	836.
10	0.0029	815.	25	2.9830	826.
11	0.0032	832.	26	3.8534	829.
12	0.0035	842.	27	4.3458	829.
13	0.0037	846.	28	5.8765	826.
14	0.0040	852.	29	7.5224	828.
15	0.0043	862.	30	9.1896	826.
			31	11.2139	823.
			32	14.1317	813.
			33	17.8829	804.
			34	22.4689	801.
			35	28.4840	806.
			36	35.9879	807.
			37	43.8624	800.

Specimen No. 5 - Step No. 9 - Initial Time = 383.833 Hours

STEP RESPONSE			RELAXATION		
	TIME (Hrs)	Ø STRAIN (Micro)		TIME (Hrs)	Ø STRAIN (Micro)
1	0.0001	11475.	16	0.0061	12217.
2	0.0004	11528.	17	0.0180	12143.
3	0.0007	11580.	18	0.0422	12196.
4	0.0009	11682.	19	0.1411	12249.
5	0.0012	11684.	20	0.3044	12249.
6	0.0017	11840.	21	0.7016	12185.
7	0.0020	11769.	22	1.0358	12196.
8	0.0023	11893.	23	1.5594	12260.
9	0.0026	11873.	24	2.0741	12196.
10	0.0028	11987.	25	2.6849	12260.
11	0.0031	12039.	26	3.2511	12196.
12	0.0034	12102.	27	4.3866	12213.
13	0.0037	12144.	28	5.5097	12224.
14	0.0040	12122.	29	6.9876	12222.
15	0.0042	12164.	30	8.7979	12235.
			31	10.9326	12229.
			32	14.1480	12221.
			33	17.5524	12208.
			34	22.2945	12205.
			35	28.4755	12215.
			36	35.7323	12218.
			37	45.0674	12221.
			38	56.7383	12218.
			39	66.3250	12218.

Specimen No. 5 - Step No. 9 - Initial Time = 383.833 Hours

STEP RESPONSE			RELAXATION		
	TIME (Hrs)	STRESS (Ksi)		TIME (Hrs)	STRESS (Ksi)
1	0.0001	16.023	16	0.0061	17.930
2	0.0004	16.176	17	0.0180	17.868
3	0.0007	16.313	18	0.0422	17.826
4	0.0009	16.438	19	0.1411	17.764
5	0.0012	16.583	20	0.3044	17.690
6	0.0017	16.832	21	0.7016	17.649
7	0.0020	16.977	22	1.0358	17.598
8	0.0023	17.113	23	1.5594	17.525
9	0.0026	17.246	24	2.0741	17.504
10	0.0028	17.362	25	2.6849	17.421
11	0.0031	17.516	26	3.2511	17.388
12	0.0034	17.619	27	4.3866	17.330
13	0.0037	17.776	28	5.5097	17.285
14	0.0040	17.909	29	6.9876	17.220
15	0.0042	17.983	30	8.7979	17.127
			31	10.9326	17.015
			32	14.1480	16.881
			33	17.5524	16.770
			34	22.2945	16.666
			35	28.4755	16.577
			36	35.7323	16.467
			37	45.0674	16.340
			38	56.7383	16.184
			39	66.3250	16.062

Specimen No. 5 - Step No. 9 - Initial Time = 383.833 Hours

STEP RESPONSE			RELAXATION		
	TIME (Hrs)	90 STRAIN (Micro)		TIME (Hrs)	90 STRAIN (Micro)
1	0.0001	-9667.	16	0.0061	-10205.
2	0.0004	-9708.	17	0.0180	-10142.
3	0.0007	-9749.	18	0.0422	-10216.
4	0.0009	-9791.	19	0.1411	-10259.
5	0.0012	-9822.	20	0.3044	-10259.
6	0.0017	-9843.	21	0.7016	-10216.
7	0.0020	-9874.	22	1.0358	-10216.
8	0.0023	-9915.	23	1.5594	-10226.
9	0.0026	-9998.	24	2.0741	-10236.
10	0.0028	-9977.	25	2.6849	-10236.
11	0.0031	-10018.	26	3.2511	-10290.
12	0.0034	-10060.	27	4.3866	-10258.
13	0.0037	-10091.	28	5.5097	-10244.
14	0.0040	-10122.	29	6.9876	-10237.
15	0.0042	-10152.	30	8.7979	-10261.
			31	10.9326	-10277.
			32	14.1480	-10303.
			33	17.5524	-10302.
			34	22.2945	-10309.
			35	28.4755	-10313.
			36	35.7323	-10319.
			37	45.0674	-10317.
			38	56.7383	-10313.
			39	66.3250	-10318.

Specimen No. 5 - Step No. 9 - Initial Time = 383.833 Hours

STEP RESPONSE			RELAXATION		
	TIME (Hrs)	45 STRAIN (Micro)		TIME (Hrs)	45 STRAIN (Micro)
1	0.0001	795.	16	0.0061	883.
2	0.0004	805.	17	0.0180	893.
3	0.0007	815.	18	0.0422	887.
4	0.0009	815.	19	0.1411	877.
5	0.0012	826.	20	0.3044	871.
6	0.0017	836.	21	0.7016	867.
7	0.0020	852.	22	1.0358	877.
8	0.0023	852.	23	1.5594	867.
9	0.0026	862.	24	2.0741	867.
10	0.0028	862.	25	2.6849	867.
11	0.0031	873.	26	3.2511	867.
12	0.0034	873.	27	4.3866	868.
13	0.0037	887.	28	5.5097	867.
14	0.0040	893.	29	6.9876	866.
15	0.0042	903.	30	8.7979	856.
			31	10.9326	848.
			32	14.1480	834.
			33	17.5524	820.
			34	22.2945	807.
			35	28.4755	803.
			36	35.7323	801.
			37	45.0674	801.
			38	56.7383	796.
			39	66.3250	796.

Specimen No. 5 - Step No. 10 - Initial Time = 453.707 Hours

STEP RESPONSE			RELAXATION		
	TIME (Hrs)	Ø STRAIN (Micro)		TIME (Hrs)	Ø STRAIN (Micro)
1	0.0006	12269.	14	0.0225	12969.
2	0.0009	12353.	15	0.0786	12969.
3	0.0012	12394.	16	0.2878	13026.
4	0.0015	12382.	17	0.6992	12969.
5	0.0018	12564.	18	1.2945	12969.
6	0.0020	12606.	19	1.7628	12969.
7	0.0023	12603.	20	2.4159	13026.
8	0.0026	12655.	21	3.2495	12969.
9	0.0029	12708.	22	4.2451	12969.
10	0.0032	12770.	23	5.5319	12984.
11	0.0034	12746.	24	6.9313	13005.
12	0.0039	12849.	25	8.9733	13005.
13	0.0042	12958.	26	10.9455	12995.
			27	14.1922	12971.
			28	18.9345	12965.
			29	21.7248	12967.
			30	28.9721	12977.
			31	34.5649	12969.
			32	43.8061	12942.

Specimen No. 5 - Step No. 10 - Initial Time = 453.707 Hours

STEP RESPONSE			RELAXATION		
	TIME (Hrs)	STRESS (Ksi)		TIME (Hrs)	STRESS (Ksi)
1	0.0006	16.210	14	0.0225	18.031
2	0.0009	16.438	15	0.0786	17.981
3	0.0012	16.591	16	0.2878	17.907
4	0.0015	16.728	17	0.6992	17.856
5	0.0018	16.852	18	1.2945	17.815
6	0.0020	16.985	19	1.7628	17.773
7	0.0023	17.130	20	2.4159	17.711
8	0.0026	17.267	21	3.2495	17.670
9	0.0029	17.400	22	4.2451	17.617
10	0.0032	17.557	23	5.5319	17.540
11	0.0034	17.681	24	6.9313	17.466
12	0.0039	17.930	25	8.9733	17.382
13	0.0042	18.055	26	10.9455	17.314
			27	14.1922	17.209
			28	18.9345	17.071
			29	21.7248	17.022
			30	28.9721	16.944
			31	34.5649	16.882
			32	43.8061	16.747



Specimen No. 5 - Step No. 10 - Initial Time = 453.707 Hours

STEP RESPONSE			RELAXATION		
	TIME (Hrs)	90 STRAIN (Micro)		TIME (Hrs)	90 STRAIN (Micro)
1	0.0006	-10392.	14	0.0225	-10910.
2	0.0009	-10454.	15	0.0786	-10977.
3	0.0012	-10485.	16	0.2878	-10920.
4	0.0015	-10516.	17	0.6992	-10988.
5	0.0018	-10568.	18	1.2945	-10920.
6	0.0020	-10609.	19	1.7628	-10920.
7	0.0023	-10640.	20	2.4159	-10988.
8	0.0026	-10682.	21	3.2495	-10941.
9	0.0029	-10723.	22	4.2451	-10928.
10	0.0032	-10754.	23	5.5319	-10937.
11	0.0034	-10786.	24	6.9313	-10959.
12	0.0039	-10848.	25	8.9733	-10985.
13	0.0042	-10833.	26	10.9455	-10971.
			27	14.1922	-10958.
			28	18.9345	-10961.
			29	21.7248	-10972.
			30	28.9721	-10991.
			31	34.5649	-10998.
			32	43.8061	-11002.

Specimen No. 5 - Step No. 10 - Initial Time = 453.707 Hours

STEP RESPONSE			RELAXATION		
	TIME (Hrs)	45 STRAIN (Micro)		TIME (Hrs)	45 STRAIN (Micro)
1	0.0006	805.	14	0.0225	877.
2	0.0009	811.	15	0.0786	877.
3	0.0012	815.	16	0.2878	867.
4	0.0015	821.	17	0.6992	867.
5	0.0018	832.	18	1.2945	877.
6	0.0020	840.	19	1.7628	867.
7	0.0023	846.	20	2.4159	867.
8	0.0026	842.	21	3.2495	867.
9	0.0029	857.	22	4.2451	864.
10	0.0032	867.	23	5.5319	856.
11	0.0034	873.	24	6.9313	852.
12	0.0039	883.	25	8.9733	847.
13	0.0042	883.	26	10.9455	845.
			27	14.1922	838.
			28	18.9345	826.
			29	21.7248	822.
			30	28.9721	817.
			31	34.5649	810.
			32	43.8061	788.

Specimen No. 5 - Step No. 11 - Initial Time = 501.828 Hours

STEP RESPONSE

RELAXATION

STEP RESPONSE			RELAXATION		
	TIME (Hrs)	Ø STRAIN (Micro)		TIME (Hrs)	Ø STRAIN (Micro)
1	0.0002	13047.	16	0.0118	13710.
2	0.0005	13021.	17	0.0212	13761.
3	0.0008	13073.	18	0.0795	13750.
4	0.0011	13204.	19	0.1453	13761.
5	0.0014	13246.	20	0.2245	13740.
6	0.0018	13261.	21	0.2933	13702.
7	0.0020	13313.	22	0.3602	13685.
8	0.0023	13365.	23	0.4327	13686.
9	0.0026	13407.	24	0.5698	13696.
10	0.0029	13470.	25	0.7119	13661.
11	0.0032	13522.	26	0.8764	13620.
12	0.0034	13574.	27	1.1736	13582.
13	0.0037	13626.	28	1.4578	13603.
14	0.0040	13668.	29	1.8466	13555.
15	0.0043	13639.	30	2.2757	13533.
			31	2.8525	13525.
			32	3.6099	13526.
			33	4.2497	13521.
			34	5.5017	13512.
			35	7.2333	13535.
			36	8.4923	13543.
			37	11.3373	13588.
			38	14.4719	13598.
			39	18.2178	13588.
			40	23.2889	13581.
			41	28.2475	13582.
			42	35.9111	13601.
			43	44.5717	13605.

Specimen No. 5 - Step No. 11 - Initial Time = 501.828 Hours

STEP RESPONSE

RELAXATION

	TIME (Hrs)	STRESS (Ksi)		TIME (Hrs)	STRESS (Ksi)
1	0.0002	16.790	16	0.0118	18.718
2	0.0005	16.935	17	0.0212	18.654
3	0.0008	17.080	18	0.0795	18.582
4	0.0011	17.205	19	0.1453	18.552
5	0.0014	17.350	20	0.2245	18.541
6	0.0018	17.566	21	0.2933	18.512
7	0.0020	17.711	22	0.3602	18.495
8	0.0023	17.847	23	0.4327	18.483
9	0.0026	17.972	24	0.5698	18.464
10	0.0029	18.126	25	0.7119	18.449
11	0.0032	18.241	26	0.8133	18.448
12	0.0034	18.386	27	0.8605	18.190
13	0.0037	18.490	28	0.9158	18.112
14	0.0040	18.635	29	1.1736	18.088
15	0.0043	18.759	30	1.4578	18.055
			31	1.8466	18.035
			32	2.2757	18.014
			33	2.8525	17.986
			34	3.6099	17.953
			35	4.2497	17.929
			36	5.5017	17.894
			37	7.2333	17.850
			38	8.4923	17.824
			39	11.3373	17.741
			40	14.4719	17.646
			41	18.2178	17.529
			42	23.2889	17.421
			43	28.2475	17.368
			44	35.9111	17.290
			45	44.5717	17.186

Specimen No. 5 - Step No. 11 - Initial Time = 501.828 Hours

STEP RESPONSE

RELAXATION

STEP RESPONSE			RELAXATION		
	TIME (Hrs)	90 STRAIN (Micro)		TIME (Hrs)	90 STRAIN (Micro)
1	0.0002	-11055.	16	0.0118	-11583.
2	0.0005	-11086.	17	0.0212	-11644.
3	0.0008	-11127.	18	0.0795	-11644.
4	0.0011	-11169.	19	0.1453	-11634.
5	0.0014	-11210.	20	0.2245	-11573.
6	0.0018	-11321.	21	0.2933	-11565.
7	0.0020	-11293.	22	0.3602	-11556.
8	0.0023	-11335.	23	0.4327	-11557.
9	0.0026	-11376.	24	0.5698	-11584.
10	0.0029	-11407.	25	0.7119	-11557.
11	0.0032	-11389.	26	0.8764	-11536.
12	0.0034	-11480.	27	1.1736	-11494.
13	0.0037	-11511.	28	1.4578	-11490.
14	0.0040	-11542.	29	1.8466	-11476.
15	0.0043	-11583.	30	2.2757	-11477.
			31	2.8525	-11487.
			32	3.6099	-11492.
			33	4.2497	-11487.
			34	5.5017	-11481.
			35	7.2333	-11506.
			36	8.4923	-11512.
			37	11.3373	-11551.
			38	14.4719	-11558.
			39	18.2178	-11565.
			40	23.2889	-11573.
			41	28.2475	-11586.
			42	35.9111	-11616.
			43	44.5717	-11641.

Specimen No. 5 - Step No. 11 - Initial Time = 501.828 Hours

STEP RESPONSE			RELAXATION		
	TIME (Hrs)	45 STRAIN (Micro)		TIME (Hrs)	45 STRAIN (Micro)
1	0.0002	780.	16	0.0118	873.
2	0.0005	780.	17	0.0212	867.
3	0.0008	795.	18	0.0795	867.
4	0.0011	805.	19	0.1453	862.
5	0.0014	805.	20	0.2245	871.
6	0.0018	815.	21	0.2933	866.
7	0.0020	826.	22	0.3602	865.
8	0.0023	836.	23	0.4327	865.
9	0.0026	842.	24	0.5698	866.
10	0.0029	846.	25	0.7119	867.
11	0.0032	852.	26	0.8764	870.
12	0.0034	862.	27	1.1736	870.
13	0.0037	862.	28	1.4578	867.
14	0.0040	873.	29	1.8466	867.
15	0.0043	873.	30	2.2757	867.
			31	2.8525	866.
			32	3.6099	864.
			33	4.2497	864.
			34	5.5017	862.
			35	7.2333	859.
			36	8.4923	856.
			37	11.3373	850.
			38	14.4719	842.
			39	18.2178	834.
			40	23.2889	826.
			41	28.2475	821.
			42	35.9111	813.
			43	44.5717	802.

Specimen No. 5 - Step No. 12 - Initial Time = 550.008 Hours

STEP RESPONSE

RELAXATION

	TIME (Hrs)	Ø STRAIN (Micro)		TIME (Hrs)	Ø STRAIN (Micro)
1	0.0005	13564.	15	0.0087	14253.
2	0.0008	13616.	16	0.0262	14392.
3	0.0010	13668.	17	0.0732	14307.
4	0.0013	13792.	18	0.1598	14307.
5	0.0016	13773.	19	0.2504	14382.
6	0.0019	13897.	20	0.4344	14296.
7	0.0022	13877.	21	0.5603	14280.
8	0.0024	13929.	22	0.7094	14283.
9	0.0027	13981.	23	0.8837	14263.
10	0.0032	14139.	24	1.0469	14283.
11	0.0034	14107.	25	1.3426	14277.
12	0.0037	14159.	26	1.7193	14286.
13	0.0040	14286.	27	2.2783	14264.
14	0.0043	14253.	28	2.7441	14262.
			29	3.5162	14305.
			30	4.3679	14359.
			31	5.8609	14398.
			32	6.8563	14415.
			33	8.8534	14406.
			34	11.8692	14399.
			35	14.3936	14386.
			36	17.3356	14370.
			37	22.4258	14333.
			38	27.0310	14319.
			39	35.6131	14314.
			40	45.0346	14305.

Specimen No. 5 - Step No. 12 - Initial Time = 550.008 Hours

STEP RESPONSE			RELAXATION			
	TIME (Hrs)	STRESS (Ksi)		TIME (Hrs)	STRESS (Ksi)	
	1	0.0005	17.267	15	0.0087	19.070
	2	0.0008	17.412	16	0.0262	19.008
	3	0.0010	17.536	17	0.0732	18.976
	4	0.0013	17.672	18	0.1598	18.936
	5	0.0016	17.817	19	0.2504	18.914
	6	0.0019	17.962	20	0.4344	18.873
	7	0.0022	18.096	21	0.5603	18.861
	8	0.0024	18.241	22	0.7094	18.839
	9	0.0027	18.386	23	0.8837	18.820
	10	0.0032	18.584	24	1.0469	18.806
	11	0.0034	18.739	25	1.3426	18.783
	12	0.0037	18.863	26	1.7193	18.739
	13	0.0040	18.997	27	2.2783	18.706
	14	0.0043	19.112	28	2.7441	18.681
				29	3.5162	18.641
				30	4.2259	18.610
				31	4.3512	18.610
				32	4.3519	18.739
				33	4.3528	19.047
				34	4.5619	19.020
				35	5.8609	18.896
				36	6.8563	18.810
				37	8.8534	18.663
				38	11.8692	18.449
				39	14.3936	18.292
				40	17.3356	18.152
				41	22.4258	17.966
				42	27.0310	17.843
				43	35.6131	17.664
				44	45.0346	17.457

Specimen No. 5 - Step No. 12 - Initial Time = 550.008 Hours

STEP RESPONSE			RELAXATION		
	TIME (Hrs)	90 STRAIN (Micro)		TIME (Hrs)	90 STRAIN (Micro)
1	0.0005	-11654.	15	0.0087	-12229.
2	0.0008	-11686.	16	0.0262	-12229.
3	0.0010	-11727.	17	0.0732	-12229.
4	0.0013	-11708.	18	0.1598	-12154.
5	0.0016	-11800.	19	0.2504	-12229.
6	0.0019	-11831.	20	0.4344	-12165.
7	0.0022	-11883.	21	0.5603	-12138.
8	0.0024	-11925.	22	0.7094	-12104.
9	0.0027	-11956.	23	0.8462	-12091.
10	0.0032	-12082.	24	1.0469	-12103.
11	0.0034	-12061.	25	1.3426	-12146.
12	0.0037	-12092.	26	1.7193	-12229.
13	0.0040	-12133.	27	2.2783	-12161.
14	0.0043	-12091.	28	2.7441	-12138.
			29	3.5162	-12170.
			30	4.3679	-12221.
			31	5.8609	-12244.
			32	6.8563	-12256.
			33	8.8534	-12256.
			34	11.8692	-12263.
			35	14.3175	-12261.
			36	17.3356	-12263.
			37	22.4258	-12262.
			38	27.0310	-12263.
			39	35.6131	-12260.
			40	45.0346	-12253.



Specimen No. 5 - Step No. 12 - Initial Time = 550.008 Hours

STEP RESPONSE			RELAXATION			
	TIME (Hrs)	45 STRAIN (Micro)		TIME (Hrs)	45 STRAIN (Micro)	
	1	0.0005	805.	15	0.0087	887.
	2	0.0008	815.	16	0.0262	882.
	3	0.0010	826.	17	0.0732	887.
	4	0.0013	826.	18	0.1598	887.
	5	0.0016	832.	19	0.2504	877.
	6	0.0019	836.	20	0.4344	877.
	7	0.0022	852.	21	0.5603	881.
	8	0.0024	857.	22	0.7094	881.
	9	0.0027	867.	23	0.8837	882.
	10	0.0032	867.	24	1.0469	879.
	11	0.0034	877.	25	1.3426	877.
	12	0.0037	887.	26	1.7193	871.
	13	0.0040	887.	27	2.2783	872.
	14	0.0043	893.	28	2.7441	872.
				29	3.5162	873.
				30	4.3679	875.
				31	5.8609	878.
				32	6.8563	879.
				33	8.8534	872.
				34	11.8692	862.
				35	14.3936	854.
				36	17.3356	847.
				37	22.4258	836.
				38	27.0310	831.
				39	35.6131	830.
				40	45.0346	828.

Specimen No. 6 - Step No. 1 - Initial Time = 0 Hours

STEP RESPONSE			RELAXATION		
	TIME (Hrs)	Ø STRAIN (Micro)		TIME (Hrs)	Ø STRAIN (Micro)
1	0.0007	66.	67	0.0458	4390.
2	0.0013	89.	68	0.0560	4374.
3	0.0018	99.	69	0.0658	4361.
4	0.0024	94.	70	0.0821	4373.
5	0.0032	110.	71	0.1013	4385.
6	0.0040	110.	72	0.1267	4361.
7	0.0045	116.	73	0.1800	4385.
8	0.0051	166.	74	0.2473	4374.
9	0.0056	237.	75	0.3684	4374.
10	0.0063	326.	76	0.4911	4360.
11	0.0071	386.	77	0.5428	4385.
12	0.0081	443.	78	0.7867	4385.
13	0.0090	515.	79	1.0648	4349.
14	0.0097	565.	80	1.3428	4373.
15	0.0104	609.	81	1.7600	4383.
16	0.0111	664.	82	2.3163	4388.
17	0.0117	705.	83	2.8739	4387.
18	0.0122	751.	84	3.5691	4395.
19	0.0131	819.	85	4.5427	4398.
20	0.0137	858.	86	5.5170	4403.
21	0.0143	919.	87	6.6467	4398.
22	0.0149	966.	88	8.8719	4402.
23	0.0157	1038.	89	11.3728	4395.
24	0.0167	1121.	90	14.1228	4394.
25	0.0177	1221.	91	17.8182	4387.
26	0.0184	1287.	92	22.4041	4393.
27	0.0189	1324.	93	28.2419	4401.
28	0.0195	1382.	94	35.7480	4407.
29	0.0201	1437.	95	46.0810	4404.
30	0.0210	1509.	96	50.9354	4407.
31	0.0217	1581.			
32	0.0222	1631.			
33	0.0228	1692.			
34	0.0233	1759.			
35	0.0240	1836.			
36	0.0246	1908.			
37	0.0252	1981.			
38	0.0257	2042.			
39	0.0263	2120.			
40	0.0269	2197.			
41	0.0276	2280.			
42	0.0281	2347.			
43	0.0287	2436.			
44	0.0292	2507.			
45	0.0299	2594.			

Specimen No. 6 - Step No. 1 - Initial Time = 0 Hours

STEP RESPONSE			RELAXATION			
	TIME (Hrs)	STRESS (Ksi)		TIME (Hrs)	STRESS (Ksi)	
	1	0.0007	0.010	67	0.0458	10.121
	2	0.0013	0.062	68	0.0560	9.988
	3	0.0018	0.073	69	0.0658	9.896
	4	0.0024	0.083	70	0.0821	9.854
	5	0.0032	0.114	71	0.1013	9.771
	6	0.0040	0.135	72	0.1267	9.750
	7	0.0045	0.146	73	0.1800	9.688
	8	0.0051	0.260	74	0.2473	9.630
	9	0.0056	0.458	75	0.3684	9.568
	10	0.0063	0.676	76	0.4911	9.553
	11	0.0071	0.853	77	0.5428	9.526
	12	0.0081	0.999	78	0.7867	9.485
	13	0.0090	1.196	79	1.0648	9.459
	14	0.0097	1.321	80	1.3428	9.417
	15	0.0104	1.456	81	1.7600	9.382
	16	0.0111	1.581	82	2.3163	9.346
	17	0.0117	1.685	83	2.8739	9.315
	18	0.0122	1.820	84	3.5691	9.281
	19	0.0131	1.986	85	4.5427	9.247
	20	0.0137	2.111	86	5.5170	9.214
	21	0.0143	2.257	87	6.6467	9.184
	22	0.0149	2.382	88	8.8719	9.131
	23	0.0157	2.569	89	11.3728	9.092
	24	0.0167	2.788	90	14.1228	9.059
	25	0.0177	3.028	91	17.8182	9.025
	26	0.0184	3.193	92	22.4041	8.998
	27	0.0189	3.318	93	28.2419	8.977
	28	0.0195	3.463	94	35.7480	8.949
	29	0.0201	3.598	95	46.0810	8.889
	30	0.0210	3.787	96	50.9354	8.840
	31	0.0217	3.951			
	32	0.0222	4.098			
	33	0.0228	4.242			
	34	0.0233	4.399			
	35	0.0240	4.564			
	36	0.0246	4.763			
	37	0.0252	4.930			
	38	0.0257	5.105			
	39	0.0263	5.282			
	40	0.0269	5.481			
	41	0.0276	5.675			
	42	0.0281	5.843			
	43	0.0287	6.018			
	44	0.0292	6.207			
	45	0.0299	6.422			

Specimen No. 6 - Step No. 1 - Initial Time = 0 Hours

STEP RESPONSE			RELAXATION		
	TIME (Hrs)	90 STRAIN (Micro)		TIME (Hrs)	90 STRAIN (Micro)
1	0.0007	-48.	67	0.0458	-3432.
2	0.0013	-59.	68	0.0560	-3427.
3	0.0018	-53.	69	0.0658	-3439.
4	0.0024	-59.	70	0.0821	-3420.
5	0.0032	-70.	71	0.1013	-3431.
6	0.0040	-64.	72	0.1267	-3431.
7	0.0045	-86.	73	0.1800	-3460.
8	0.0051	-106.	74	0.2473	-3489.
9	0.0056	-166.	75	0.3684	-3482.
10	0.0063	-235.	76	0.4911	-3442.
11	0.0071	-289.	77	0.5428	-3492.
12	0.0081	-342.	78	0.7867	-3503.
13	0.0090	-398.	79	1.0648	-3492.
14	0.0097	-438.	80	1.3428	-3503.
15	0.0104	-484.	81	1.7600	-3503.
16	0.0111	-525.	82	2.3163	-3504.
17	0.0117	-562.	83	2.8739	-3511.
18	0.0122	-581.	84	3.5691	-3517.
19	0.0131	-632.	85	4.5427	-3526.
20	0.0137	-682.	86	5.5170	-3537.
21	0.0143	-718.	87	6.6467	-3541.
22	0.0149	-758.	88	8.8719	-3553.
23	0.0157	-815.	89	11.3728	-3556.
24	0.0167	-887.	90	14.1228	-3558.
25	0.0177	-962.	91	17.8182	-3561.
26	0.0184	-1010.	92	22.4041	-3566.
27	0.0189	-1058.	93	28.2419	-3579.
28	0.0195	-1091.	94	35.7480	-3592.
29	0.0201	-1128.	95	46.0810	-3604.
30	0.0210	-1193.	96	50.9354	-3639.
31	0.0217	-1238.			
32	0.0222	-1281.			
33	0.0228	-1329.			
34	0.0233	-1375.			
35	0.0240	-1440.			
36	0.0246	-1495.			
37	0.0252	-1543.			
38	0.0257	-1583.			
39	0.0263	-1646.			
40	0.0269	-1709.			
41	0.0276	-1764.			
42	0.0281	-1822.			
43	0.0287	-1887.			
44	0.0292	-1950.			
45	0.0299	-2015.			

Specimen No. 6 - Step No. 1 - Initial Time = 0 Hours

STEP RESPONSE			RELAXATION		
	TIME (Hrs)	45 STRAIN (Micro)		TIME (Hrs)	45 STRAIN (Micro)
1	0.0007	17.	67	0.0458	412.
2	0.0013	28.	68	0.0560	407.
3	0.0018	34.	69	0.0658	406.
4	0.0024	34.	70	0.0821	404.
5	0.0032	40.	71	0.1013	397.
6	0.0040	40.	72	0.1267	397.
7	0.0045	34.	73	0.1800	383.
8	0.0051	40.	74	0.2473	381.
9	0.0056	57.	75	0.3684	372.
10	0.0063	63.	76	0.4911	390.
11	0.0071	68.	77	0.5428	374.
12	0.0081	68.	78	0.7867	372.
13	0.0090	91.	79	1.0648	383.
14	0.0097	91.	80	1.3428	374.
15	0.0104	91.	81	1.7600	370.
16	0.0111	102.	82	2.3163	365.
17	0.0117	102.	83	2.8739	362.
18	0.0122	107.	84	3.5691	363.
19	0.0131	113.	85	4.5427	364.
20	0.0137	125.	86	5.5170	361.
21	0.0143	131.	87	6.6467	359.
22	0.0149	125.	88	8.8719	354.
23	0.0157	136.	89	11.3728	350.
24	0.0167	142.	90	14.1228	347.
25	0.0177	153.	91	17.8182	342.
26	0.0184	169.	92	22.4041	339.
27	0.0189	165.	93	28.2419	337.
28	0.0195	165.	94	35.7480	334.
29	0.0201	181.	95	46.0810	324.
30	0.0210	192.	96	50.9354	317.
31	0.0217	187.			
32	0.0222	198.			
33	0.0228	205.			
34	0.0233	215.			
35	0.0240	210.			
36	0.0246	226.			
37	0.0252	232.			
38	0.0257	242.			
39	0.0263	249.			
40	0.0269	259.			
41	0.0276	259.			
42	0.0281	271.			
43	0.0287	272.			
44	0.0292	288.			
45	0.0299	288.			

Specimen No. 6 - Step No. 2 - Initial Time = 51.449 Hours

STEP RESPONSE			RELAXATION		
	TIME (Hrs)	Ø STRAIN (Micro)		TIME (Hrs)	Ø STRAIN (Micro)
1	0.0004	4439.	29	0.0107	5947.
2	0.0007	4530.	30	0.0154	5947.
3	0.0010	4572.	31	0.0243	5936.
4	0.0014	4675.	32	0.0352	5924.
5	0.0017	4731.	33	0.0604	5924.
6	0.0019	4764.	34	0.1009	5924.
7	0.0022	4820.	35	0.1814	5924.
8	0.0025	4839.	36	0.2695	5893.
9	0.0028	4920.	37	0.3862	5956.
10	0.0030	4938.	38	0.6170	5956.
11	0.0033	4983.	39	0.9448	5924.
12	0.0036	5049.	40	1.3564	5947.
13	0.0039	5094.	41	1.9314	5979.
14	0.0044	5210.	42	2.9086	5966.
15	0.0047	5227.	43	3.4212	5974.
16	0.0050	5283.	44	4.3161	5989.
17	0.0053	5355.	45	5.6473	5995.
18	0.0055	5400.	46	6.9666	5994.
19	0.0058	5427.	47	8.4899	5990.
20	0.0061	5471.	48	11.2977	5989.
21	0.0064	5556.	49	14.2155	5978.
22	0.0066	5571.	50	18.0400	5972.
23	0.0069	5615.	51	22.6471	5982.
24	0.0074	5724.	52	28.4825	5996.
25	0.0077	5779.	53	35.9852	6004.
26	0.0079	5867.	54	44.7383	6001.
27	0.0082	5860.			
28	0.0085	5936.			

Specimen No. 6 - Step No. 2 - Initial Time = 51.449 Hours

STEP RESPONSE

RELAXATION

STEP RESPONSE			RELAXATION		
	TIME (Hrs)	STRESS (Ksi)		TIME (Hrs)	STRESS (Ksi)
1	0.0004	9.006	29	0.0107	12.370
2	0.0007	9.168	30	0.0154	12.307
3	0.0010	9.293	31	0.0243	12.245
4	0.0014	9.480	32	0.0352	12.162
5	0.0017	9.605	33	0.0604	12.099
6	0.0019	9.734	34	0.1009	12.037
7	0.0022	9.854	35	0.1814	11.954
8	0.0025	9.963	36	0.2695	11.912
9	0.0028	10.109	37	0.3862	11.856
10	0.0030	10.207	38	0.6170	11.794
11	0.0033	10.327	39	0.9448	11.731
12	0.0036	10.457	40	1.3564	11.690
13	0.0039	10.561	41	1.9314	11.669
14	0.0044	10.795	42	2.9086	11.620
15	0.0047	10.894	43	3.4212	11.599
16	0.0050	11.018	44	4.3161	11.570
17	0.0053	11.149	45	5.6473	11.522
18	0.0055	11.226	46	6.9666	11.475
19	0.0058	11.351	47	8.4899	11.423
20	0.0061	11.449	48	11.2977	11.344
21	0.0064	11.580	49	14.2155	11.288
22	0.0066	11.690	50	18.0400	11.231
23	0.0069	11.808	51	22.6471	11.204
24	0.0074	11.981	52	28.4825	11.163
25	0.0077	12.099	53	35.9852	11.118
26	0.0079	12.210	54	44.7383	11.052
27	0.0082	12.328			
28	0.0085	12.432			

Specimen No. 6 - Step No. 2 - Initial Time = 51.449 Hours

STEP RESPONSE			RELAXATION		
	TIME (Hrs)	90 STRAIN (Micro)		TIME (Hrs)	90 STRAIN (Micro)
1	0.0004	-3662.	29	0.0107	-4775.
2	0.0007	-3686.	30	0.0154	-4739.
3	0.0010	-3709.	31	0.0243	-4750.
4	0.0014	-3803.	32	0.0352	-4750.
5	0.0017	-3846.	33	0.0604	-4786.
6	0.0019	-3889.	34	0.1009	-4786.
7	0.0022	-3901.	35	0.1814	-4797.
8	0.0025	-3954.	36	0.2695	-4797.
9	0.0028	-3965.	37	0.3862	-4844.
10	0.0030	-4008.	38	0.6170	-4818.
11	0.0033	-4030.	39	0.9448	-4829.
12	0.0036	-4073.	40	1.3564	-4840.
13	0.0039	-4116.	41	1.9314	-4877.
14	0.0044	-4180.	42	2.9086	-4836.
15	0.0047	-4223.	43	3.4212	-4858.
16	0.0050	-4255.	44	4.3161	-4873.
17	0.0053	-4298.	45	5.6473	-4877.
18	0.0055	-4343.	46	6.9666	-4875.
19	0.0058	-4386.	47	8.4899	-4876.
20	0.0061	-4429.	48	11.2977	-4892.
21	0.0064	-4438.	49	14.2155	-4890.
22	0.0066	-4494.	50	18.0400	-4900.
23	0.0069	-4524.	51	22.6471	-4902.
24	0.0074	-4602.	52	28.4825	-4915.
25	0.0077	-4621.	53	35.9852	-4928.
26	0.0079	-4678.	54	44.7383	-4947.
27	0.0082	-4721.			
28	0.0085	-4717.			



Specimen No. 6 - Step No. 2 - Initial Time = 51.449 Hours

STEP RESPONSE			RELAXATION		
	TIME (Hrs)	45 STRAIN (Micro)		TIME (Hrs)	45 STRAIN (Micro)
1	0.0004	327.	29	0.0107	442.
2	0.0007	335.	30	0.0154	462.
3	0.0010	336.	31	0.0243	451.
4	0.0014	350.	32	0.0352	440.
5	0.0017	351.	33	0.0604	442.
6	0.0019	350.	34	0.1009	431.
7	0.0022	361.	35	0.1814	428.
8	0.0025	361.	36	0.2695	431.
9	0.0028	372.	37	0.3862	422.
10	0.0030	379.	38	0.6170	419.
11	0.0033	383.	39	0.9448	417.
12	0.0036	381.	40	1.3564	410.
13	0.0039	385.	41	1.9314	399.
14	0.0044	406.	42	2.9086	416.
15	0.0047	404.	43	3.4212	416.
16	0.0050	406.	44	4.3161	415.
17	0.0053	406.	45	5.6473	415.
18	0.0055	417.	46	6.9666	413.
19	0.0058	428.	47	8.4899	411.
20	0.0061	431.	48	11.2977	402.
21	0.0064	426.	49	14.2155	397.
22	0.0066	419.	50	18.0400	391.
23	0.0069	440.	51	22.6471	391.
24	0.0074	440.	52	28.4825	390.
25	0.0077	440.	53	35.9852	386.
26	0.0079	451.	54	44.7383	375.
27	0.0082	462.			
28	0.0085	451.			

Specimen No. 6 - Step No. 3 - Initial Time = 100.588 Hours

STEP RESPONSE			RELAXATION		
	TIME (Hrs)	Ø STRAIN (Micro)		TIME (Hrs)	Ø STRAIN (Micro)
1	0.0000	6036.	30	0.0114	7628.
2	0.0003	6103.	31	0.0156	7628.
3	0.0007	6181.	32	0.0238	7616.
4	0.0010	6248.	33	0.0377	7616.
5	0.0013	6304.	34	0.0563	7576.
6	0.0015	6360.	35	0.0811	7565.
7	0.0018	6404.	36	0.1250	7576.
8	0.0021	6483.	37	0.1680	7616.
9	0.0024	6516.	38	0.2422	7605.
10	0.0026	6549.	39	0.3625	7576.
11	0.0029	6641.	40	0.4463	7574.
12	0.0032	6661.	41	0.5613	7549.
13	0.0038	6798.	42	0.8396	7520.
14	0.0041	6817.	43	1.0810	7572.
15	0.0043	6899.	44	1.5305	7531.
16	0.0046	6943.	45	1.8319	7572.
17	0.0049	6999.	46	2.5013	7583.
18	0.0052	7007.	47	3.1174	7583.
19	0.0055	7089.	48	3.5701	7573.
20	0.0057	7156.	49	4.6072	7574.
21	0.0060	7163.	50	5.5004	7594.
22	0.0063	7230.	51	6.8424	7574.
23	0.0067	7297.	52	9.1019	7548.
24	0.0070	7341.	53	11.5635	7545.
25	0.0073	7437.	54	14.2626	7539.
26	0.0075	7442.	55	17.9423	7550.
27	0.0078	7538.	56	22.5277	7551.
28	0.0081	7583.	57	28.3685	7557.
29	0.0084	7628.	58	35.8711	7562.
			59	43.7947	7558.

Specimen No. 6 - Step No. 3 - Initial Time = 100.588 Hours

STEP RESPONSE			RELAXATION		
	TIME (Hrs)	STRESS (Ksi)		TIME (Hrs)	STRESS (Ksi)
1	0.0000	11.143	30	0.0114	14.596
2	0.0003	11.304	31	0.0156	14.511
3	0.0007	11.482	32	0.0238	14.456
4	0.0010	11.648	33	0.0377	14.393
5	0.0013	11.794	34	0.0563	14.303
6	0.0015	11.912	35	0.0811	14.261
7	0.0018	12.037	36	0.1250	14.178
8	0.0021	12.147	37	0.1680	14.137
9	0.0024	12.272	38	0.2422	14.061
10	0.0026	12.390	39	0.3625	14.012
11	0.0029	12.522	40	0.4463	13.909
12	0.0032	12.619	41	0.5613	13.811
13	0.0038	12.889	42	0.8396	13.762
14	0.0041	13.014	43	1.0810	13.707
15	0.0043	13.104	44	1.5305	13.638
16	0.0046	13.208	45	1.8319	13.610
17	0.0049	13.354	46	2.5013	13.513
18	0.0052	13.458	47	3.1174	13.478
19	0.0055	13.555	48	3.5701	13.464
20	0.0057	13.666	49	4.6072	13.398
21	0.0060	13.804	50	5.5004	13.305
22	0.0063	13.901	51	6.8424	13.264
23	0.0067	14.074	52	9.1019	13.177
24	0.0070	14.178	53	11.5635	13.091
25	0.0073	14.282	54	14.2626	13.019
26	0.0075	14.386	55	17.9423	12.950
27	0.0078	14.497	56	22.5277	12.903
28	0.0081	14.594	57	28.3685	12.839
29	0.0084	14.698	58	35.8711	12.755
			59	43.7947	12.663

Specimen No. 6 - Step No. 3 - Initial Time = 100.588 Hours

STEP RESPONSE			RELAXATION		
	TIME (Hrs)	90 STRAIN (Micro)		TIME (Hrs)	90 STRAIN (Micro)
1	0.0000	-4991.	30	0.0114	-6163.
2	0.0003	-5018.	31	0.0156	-6147.
3	0.0007	-5083.	32	0.0238	-6158.
4	0.0010	-5153.	33	0.0377	-6158.
5	0.0013	-5196.	34	0.0563	-6114.
6	0.0015	-5212.	35	0.0811	-6158.
7	0.0018	-5272.	36	0.1250	-6169.
8	0.0021	-5315.	37	0.1680	-6179.
9	0.0024	-5348.	38	0.2422	-6190.
10	0.0026	-5391.	39	0.3625	-6157.
11	0.0029	-5452.	40	0.4463	-6166.
12	0.0032	-5456.	41	0.5613	-6169.
13	0.0038	-5531.	42	0.8396	-6147.
14	0.0041	-5574.	43	1.0810	-6224.
15	0.0043	-5648.	44	1.5305	-6201.
16	0.0046	-5650.	45	1.8319	-6245.
17	0.0049	-5652.	46	2.5013	-6223.
18	0.0052	-5715.	47	3.1174	-6233.
19	0.0055	-5758.	48	3.5701	-6238.
20	0.0057	-5801.	49	4.6072	-6240.
21	0.0060	-5803.	50	5.5004	-6278.
22	0.0063	-5793.	51	6.8424	-6250.
23	0.0067	-5889.	52	9.1019	-6232.
24	0.0070	-5921.	53	11.5635	-6231.
25	0.0073	-6028.	54	14.2626	-6243.
26	0.0075	-6007.	55	17.9423	-6257.
27	0.0078	-6039.	56	22.5277	-6260.
28	0.0081	-6104.	57	28.3685	-6262.
29	0.0084	-6147.	58	35.8711	-6271.
			59	43.7947	-6290.

Specimen No. 6 - Step No. 3 - Initial Time = 100.588 Hours

STEP RESPONSE			RELAXATION		
	TIME (Hrs)	45 STRAIN (Micro)		TIME (Hrs)	45 STRAIN (Micro)
1	0.0000	370.	30	0.0114	504.
2	0.0003	381.	31	0.0156	507.
3	0.0007	383.	32	0.0238	499.
4	0.0010	395.	33	0.0377	496.
5	0.0013	393.	34	0.0563	491.
6	0.0015	406.	35	0.0811	485.
7	0.0018	408.	36	0.1250	482.
8	0.0021	408.	37	0.1680	485.
9	0.0024	417.	38	0.2422	476.
10	0.0026	417.	39	0.3625	474.
11	0.0029	419.	40	0.4463	476.
12	0.0032	426.	41	0.5613	476.
13	0.0038	437.	42	0.8396	474.
14	0.0041	442.	43	1.0810	476.
15	0.0043	440.	44	1.5305	469.
16	0.0046	451.	45	1.8319	451.
17	0.0049	462.	46	2.5013	462.
18	0.0052	460.	47	3.1174	451.
19	0.0055	462.	48	3.5701	453.
20	0.0057	474.	49	4.6072	454.
21	0.0060	482.	50	5.5004	451.
22	0.0063	482.	51	6.8424	448.
23	0.0067	485.	52	9.1019	442.
24	0.0070	496.	53	11.5635	438.
25	0.0073	493.	54	14.2626	433.
26	0.0075	493.	55	17.9423	429.
27	0.0078	505.	56	22.5277	427.
28	0.0081	507.	57	28.3685	428.
29	0.0084	510.	58	35.8711	425.
			59	43.7947	419.

Specimen No. 6 - Step No. 4 - Initial Time = 148.224 Hours

STEP RESPONSE			RELAXATION		
	TIME (Hrs)	Ø STRAIN (Micro)		TIME (Hrs)	Ø STRAIN (Micro)
1	0.0006	7639.	15	0.0089	8413.
2	0.0009	7654.	16	0.0330	8447.
3	0.0011	7710.	17	0.1590	8413.
4	0.0014	7788.	18	0.4031	8402.
5	0.0017	7843.	19	0.8401	8413.
6	0.0020	7953.	20	1.5712	8346.
7	0.0025	8054.	21	2.0468	8424.
8	0.0027	8078.	22	2.9007	8407.
9	0.0030	8166.	23	3.8793	8401.
10	0.0033	8178.	24	4.6960	8401.
11	0.0036	8267.	25	5.5296	8357.
12	0.0039	8323.	26	6.7509	8391.
13	0.0041	8334.	27	8.8055	8401.
14	0.0044	8379.	28	11.3063	8399.
			29	14.2241	8386.
			30	17.9769	8394.
			31	22.5635	8397.
			32	28.3996	8409.
			33	35.9023	8410.
			34	45.0075	8413.

Specimen No. 6 - Step No. 4 - Initial Time = 148.224 Hours

STEP RESPONSE			RELAXATION		
	TIME (Hrs)	STRESS (Ksi)		TIME (Hrs)	STRESS (Ksi)
1	0.0006	12.765	15	0.0089	14.552
2	0.0009	12.917	16	0.0330	14.490
3	0.0011	13.056	17	0.1590	14.414
4	0.0014	13.208	18	0.4031	14.373
5	0.0017	13.388	19	0.8401	14.324
6	0.0020	13.520	20	1.5712	14.296
7	0.0025	13.770	21	2.0468	14.227
8	0.0027	13.908	22	2.9007	14.207
9	0.0030	14.040	23	3.8793	14.157
10	0.0033	14.157	24	4.6960	14.123
11	0.0036	14.261	25	5.5296	14.088
12	0.0039	14.386	26	6.7509	14.038
13	0.0041	14.511	27	8.8055	13.958
14	0.0044	14.615	28	11.3063	13.877
			29	14.2241	13.803
			30	17.9769	13.727
			31	22.5635	13.658
			32	28.3996	13.568
			33	35.9023	13.459
			34	45.0075	13.329

Specimen No. 6 - Step No. 4 - Initial Time = 148.224 Hours

STEP RESPONSE			RELAXATION		
	TIME (Hrs)	90 STRAIN (Micro)		TIME (Hrs)	90 STRAIN (Micro)
1	0.0006	-6341.	15	0.0089	-6903.
2	0.0009	-6408.	16	0.0330	-6914.
3	0.0011	-6462.	17	0.1590	-6914.
4	0.0014	-6471.	18	0.4031	-6962.
5	0.0017	-6480.	19	0.8401	-6925.
6	0.0020	-6523.	20	1.5712	-6841.
7	0.0025	-6644.	21	2.0468	-6984.
8	0.0027	-6687.	22	2.9007	-6926.
9	0.0030	-6720.	23	3.8793	-6910.
10	0.0033	-6763.	24	4.6960	-6946.
11	0.0036	-6806.	25	5.5296	-6920.
12	0.0039	-6828.	26	6.7509	-6950.
13	0.0041	-6871.	27	8.8055	-6961.
14	0.0044	-6903.	28	11.3063	-6957.
			29	14.2241	-6963.
			30	17.9769	-6981.
			31	22.5635	-6988.
			32	28.3996	-6986.
			33	35.9023	-6990.
			34	45.0075	-7002.

Specimen No. 6 - Step No. 4 - Initial Time = 148.224 Hours

STEP RESPONSE			RELAXATION		
	TIME (Hrs)	45 STRAIN (Micro)		TIME (Hrs)	45 STRAIN (Micro)
1	0.0006	426.	15	0.0089	485.
2	0.0009	428.	16	0.0330	485.
3	0.0011	442.	17	0.1590	482.
4	0.0014	449.	18	0.4031	476.
5	0.0017	446.	19	0.8401	485.
6	0.0020	451.	20	1.5712	488.
7	0.0025	474.	21	2.0468	471.
8	0.0027	476.	22	2.9007	478.
9	0.0030	476.	23	3.8793	469.
10	0.0033	471.	24	4.6960	474.
11	0.0036	482.	25	5.5296	482.
12	0.0039	496.	26	6.7509	478.
13	0.0041	493.	27	8.8055	471.
14	0.0044	493.	28	11.3063	462.
			29	14.2241	456.
			30	17.9769	449.
			31	22.5635	451.
			32	28.3996	455.
			33	35.9023	454.
			34	45.0075	443.

Specimen No. 6 - Step No. 5 - Initial Time = 197.091 Hours

STEP RESPONSE			RELAXATION		
	TIME (Hrs)	Ø STRAIN (Micro)		TIME (Hrs)	Ø STRAIN (Micro)
1	0.0003	8502.	15	0.0101	9260.
2	0.0006	8557.	16	0.0328	9299.
3	0.0009	8613.	17	0.1126	9299.
4	0.0012	8680.	18	0.2543	9299.
5	0.0015	8783.	19	0.5465	9299.
6	0.0017	8803.	20	0.9706	9299.
7	0.0020	8870.	21	1.4755	9310.
8	0.0026	8970.	22	2.1903	9270.
9	0.0028	8989.	23	2.7197	9321.
10	0.0031	9131.	24	3.4966	9310.
11	0.0034	9127.	25	4.4849	9292.
12	0.0037	9171.	26	5.9308	9278.
13	0.0039	9277.	27	6.7129	9274.
14	0.0042	9321.	28	8.9434	9275.
			29	11.1807	9267.
			30	13.9666	9264.
			31	17.2841	9262.
			32	22.5394	9263.
			33	28.3758	9271.
			34	35.8785	9281.

Specimen No. 6 - Step No. 5 - Initial Time = 197.091 Hours

STEP RESPONSE			RELAXATION		
	TIME (Hrs)	STRESS (Ksi)		TIME (Hrs)	STRESS (Ksi)
1	0.0003	13.513	15	0.0101	15.259
2	0.0006	13.658	16	0.0328	15.197
3	0.0009	13.804	17	0.1126	15.114
4	0.0012	13.970	18	0.2543	15.101
5	0.0015	14.109	19	0.5465	15.017
6	0.0017	14.254	20	0.9706	14.968
7	0.0020	14.407	21	1.4755	14.927
8	0.0026	14.656	22	2.1903	14.889
9	0.0028	14.781	23	2.7197	14.823
10	0.0031	14.906	24	3.4966	14.781
11	0.0034	15.031	25	4.4849	14.719
12	0.0037	15.114	26	5.9308	14.651
13	0.0039	15.238	27	6.7129	14.619
14	0.0042	15.350	28	8.9434	14.533
			29	11.1807	14.456
			30	13.9666	14.380
			31	17.2841	14.314
			32	22.5394	14.245
			33	28.3758	14.167
			34	35.8785	14.060



Specimen No. 6 - Step No. 5 - Initial Time = 197.091 Hours

STEP RESPONSE			RELAXATION		
	TIME (Hrs)	90 STRAIN (Micro)		TIME (Hrs)	90 STRAIN (Micro)
1	0.0003	-7028.	15	0.0101	-7627.
2	0.0006	-7109.	16	0.0328	-7668.
3	0.0009	-7124.	17	0.1126	-7638.
4	0.0012	-7167.	18	0.2543	-7649.
5	0.0015	-7221.	19	0.5465	-7649.
6	0.0017	-7253.	20	0.9706	-7701.
7	0.0020	-7346.	21	1.4755	-7712.
8	0.0026	-7422.	22	2.1903	-7636.
9	0.0028	-7425.	23	2.7197	-7681.
10	0.0031	-7497.	24	3.4966	-7681.
11	0.0034	-7541.	25	4.4849	-7656.
12	0.0037	-7573.	26	5.9308	-7661.
13	0.0039	-7565.	27	6.7129	-7667.
14	0.0042	-7649.	28	8.9434	-7692.
			29	11.1807	-7694.
			30	13.9666	-7702.
			31	17.2841	-7708.
			32	22.5394	-7721.
			33	28.3758	-7738.
			34	35.8785	-7756.

Specimen No. 6 - Step No. 5 - Initial Time = 197.091 Hours

STEP RESPONSE			RELAXATION		
	TIME (Hrs)	45 STRAIN (Micro)		TIME (Hrs)	45 STRAIN (Micro)
1	0.0003	457.	15	0.0101	516.
2	0.0006	474.	16	0.0328	516.
3	0.0009	471.	17	0.1126	519.
4	0.0012	482.	18	0.2543	505.
5	0.0015	485.	19	0.5465	510.
6	0.0017	488.	20	0.9706	507.
7	0.0020	491.	21	1.4755	505.
8	0.0026	505.	22	2.1903	510.
9	0.0028	505.	23	2.7197	505.
10	0.0031	513.	24	3.4966	505.
11	0.0034	516.	25	4.4849	505.
12	0.0037	516.	26	5.9308	501.
13	0.0039	530.	27	6.7129	498.
14	0.0042	516.	28	8.9434	488.
			29	11.1807	483.
			30	13.9666	479.
			31	17.2841	474.
			32	22.5394	468.
			33	28.3758	462.
			34	35.8785	453.

Specimen No. 6 - Step No. 6 - Initial Time = 237.231 Hours

STEP RESPONSE			RELAXATION		
	TIME (Hrs)	Ø STRAIN (Micro)		TIME (Hrs)	Ø STRAIN (Micro)
1	0.0001	9366.	16	0.0064	10140.
2	0.0004	9383.	17	0.0167	10172.
3	0.0007	9439.	18	0.0639	10118.
4	0.0010	9495.	19	0.1589	10161.
5	0.0014	9635.	20	0.3812	10107.
6	0.0016	9703.	21	0.8198	10107.
7	0.0019	9759.	22	1.2451	10107.
8	0.0022	9774.	23	1.9669	10096.
9	0.0025	9829.	24	1.9957	10107.
10	0.0028	9927.	25	2.7204	10095.
11	0.0030	9994.	26	3.3504	10095.
12	0.0033	10028.	27	4.4870	10082.
13	0.0036	10073.	28	5.7065	10019.
14	0.0039	10075.	29	6.9570	10054.
15	0.0042	10097.	30	9.0410	10093.
			31	11.5230	10098.
			32	14.4406	10075.
			33	18.1919	10058.
			34	22.2552	10052.
			35	28.0868	10064.
			36	35.8780	10067.
			37	45.0878	10081.
			38	50.4193	10085.

Specimen No. 6 - Step No. 6 - Initial Time = 237.231 Hours

STEP RESPONSE			RELAXATION		
	TIME (Hrs)	STRESS (Ksi)		TIME (Hrs)	STRESS (Ksi)
1	0.0001	14.178	16	0.0064	15.987
2	0.0004	14.345	17	0.0167	15.904
3	0.0007	14.490	18	0.0639	15.841
4	0.0010	14.643	19	0.1589	15.808
5	0.0014	14.843	20	0.3812	15.737
6	0.0016	14.989	21	0.8198	15.662
7	0.0019	15.135	22	1.2451	15.621
8	0.0022	15.280	23	1.9669	15.549
9	0.0025	15.405	24	1.9957	15.530
10	0.0028	15.537	25	2.7204	15.496
11	0.0030	15.641	26	3.3504	15.426
12	0.0033	15.766	27	4.4870	15.335
13	0.0036	15.883	28	5.7065	15.259
14	0.0039	15.987	29	6.9570	15.219
15	0.0042	16.049	30	9.0410	15.168
			31	11.5230	15.096
			32	14.4406	15.008
			33	18.1919	14.884
			34	22.2552	14.788
			35	28.0868	14.700
			36	35.8780	14.607
			37	45.0878	14.504
			38	50.4193	14.448

Specimen No. 6 - Step No. 6 - Initial Time = 237.231 Hours

STEP RESPONSE			RELAXATION		
	TIME (Hrs)	90 STRAIN (Micro)		TIME (Hrs)	90 STRAIN (Micro)
1	0.0001	-7780.	16	0.0064	-8394.
2	0.0004	-7876.	17	0.0167	-8428.
3	0.0007	-7908.	18	0.0639	-8383.
4	0.0010	-8005.	19	0.1589	-8439.
5	0.0014	-7984.	20	0.3812	-8394.
6	0.0016	-8070.	21	0.8198	-8394.
7	0.0019	-8113.	22	1.2451	-8450.
8	0.0022	-8102.	23	1.9669	-8417.
9	0.0025	-8244.	24	1.9957	-8416.
10	0.0028	-8243.	25	2.7204	-8461.
11	0.0030	-8275.	26	3.3504	-8416.
12	0.0033	-8308.	27	4.4870	-8410.
13	0.0036	-8296.	28	5.7065	-8405.
14	0.0039	-8372.	29	6.9570	-8414.
15	0.0042	-8439.	30	9.0410	-8430.
			31	11.5230	-8429.
			32	14.4406	-8414.
			33	18.1919	-8413.
			34	22.2552	-8425.
			35	28.0868	-8449.
			36	35.8780	-8458.
			37	45.0878	-8471.
			38	50.4193	-8488.

Specimen No. 6 - Step No. 6 - Initial Time = 237.231 Hours

STEP RESPONSE			RELAXATION		
	TIME (Hrs)	45 STRAIN (Micro)		TIME (Hrs)	45 STRAIN (Micro)
1	0.0001	449.	16	0.0064	513.
2	0.0004	462.	17	0.0167	516.
3	0.0007	471.	18	0.0639	513.
4	0.0010	469.	19	0.1589	505.
5	0.0014	482.	20	0.3812	507.
6	0.0016	496.	21	0.8198	505.
7	0.0019	493.	22	1.2451	496.
8	0.0022	502.	23	1.9669	506.
9	0.0025	507.	24	1.9957	493.
10	0.0028	507.	25	2.7204	496.
11	0.0030	507.	26	3.3504	493.
12	0.0033	519.	27	4.4870	488.
13	0.0036	519.	28	5.7065	491.
14	0.0039	527.	29	6.9570	492.
15	0.0042	524.	30	9.0410	491.
			31	11.5230	490.
			32	14.4406	489.
			33	18.1919	482.
			34	22.2552	474.
			35	28.0868	467.
			36	35.8780	463.
			37	45.0878	458.
			38	50.4193	456.

Specimen No. 6 - Step No. 7 - Initial Time = 288.177 Hours

STEP RESPONSE			RELAXATION		
	TIME (Hrs)	Ø STRAIN (Micro)		TIME (Hrs)	Ø STRAIN (Micro)
1	0.0006	10185.	15	0.0087	10959.
2	0.0009	10241.	16	0.0317	10948.
3	0.0011	10297.	17	0.1184	10996.
4	0.0014	10365.	18	0.3062	10937.
5	0.0019	10466.	19	0.5134	10937.
6	0.0022	10522.	20	0.9631	10996.
7	0.0024	10589.	21	1.0353	10937.
8	0.0027	10656.	22	1.6473	10937.
9	0.0030	10770.	23	2.4095	10948.
10	0.0033	10711.	24	3.5466	10917.
11	0.0035	10778.	25	4.6860	10889.
12	0.0038	10892.	26	5.5211	10900.
13	0.0041	10878.	27	6.7715	10930.
14	0.0044	10912.	28	9.1676	10939.
			29	11.5188	10934.
			30	14.3651	10940.
			31	18.2092	10926.
			32	22.7966	10934.
			33	28.6340	10929.
			34	35.7205	10934.
			35	44.0568	10920.

Specimen No. 6 - Step No. 7 - Initial Time = 288.177 Hours

STEP RESPONSE			RELAXATION		
	TIME (Hrs)	STRESS (Ksi)		TIME (Hrs)	STRESS (Ksi)
1	0.0006	14.656	15	0.0087	16.465
2	0.0009	14.823	16	0.0317	16.411
3	0.0011	14.968	17	0.1184	16.319
4	0.0014	15.114	18	0.3062	16.278
5	0.0019	15.363	19	0.5134	16.236
6	0.0022	15.509	20	0.9631	16.182
7	0.0024	15.633	21	1.0353	16.174
8	0.0027	15.800	22	1.6473	16.120
9	0.0030	15.916	23	2.4095	16.070
10	0.0033	16.070	24	3.5466	16.029
11	0.0035	16.207	25	4.6860	15.987
12	0.0038	16.332	26	5.5211	15.945
13	0.0041	16.457	27	6.7715	15.896
14	0.0044	16.540	28	9.1676	15.801
			29	11.5188	15.717
			30	14.3651	15.621
			31	18.2092	15.532
			32	22.7966	15.463
			33	28.6340	15.380
			34	35.7205	15.277
			35	44.0568	15.132

Specimen No. 6 - Step No. 7 - Initial Time = 288.177 Hours

STEP RESPONSE			RELAXATION		
	TIME (Hrs)	90 STRAIN (Micro)		TIME (Hrs)	90 STRAIN (Micro)
1	0.0006	-8500.	15	0.0087	-9118.
2	0.0009	-8646.	16	0.0317	-9167.
3	0.0011	-8689.	17	0.1184	-9118.
4	0.0014	-8686.	18	0.3062	-9118.
5	0.0019	-8761.	19	0.5134	-9178.
6	0.0022	-8805.	20	0.9631	-9189.
7	0.0024	-8848.	21	1.0353	-9129.
8	0.0027	-8891.	22	1.6473	-9140.
9	0.0030	-8934.	23	2.4095	-9200.
10	0.0033	-8977.	24	3.5466	-9153.
11	0.0035	-8951.	25	4.6860	-9183.
12	0.0038	-8947.	26	5.5211	-9194.
13	0.0041	-9086.	27	6.7715	-9193.
14	0.0044	-9069.	28	9.1676	-9188.
			29	11.5188	-9189.
			30	14.3651	-9191.
			31	18.2092	-9211.
			32	22.7966	-9226.
			33	28.6340	-9236.
			34	35.7205	-9241.
			35	44.0568	-9248.

Specimen No. 6 - Step No. 7 - Initial Time = 288.177 Hours

STEP RESPONSE			RELAXATION		
	TIME (Hrs)	45 STRAIN (Micro)		TIME (Hrs)	45 STRAIN (Micro)
1	0.0006	462.	15	0.0087	524.
2	0.0009	471.	16	0.0317	527.
3	0.0011	485.	17	0.1184	527.
4	0.0014	482.	18	0.3062	516.
5	0.0019	491.	19	0.5134	516.
6	0.0022	505.	20	0.9631	505.
7	0.0024	502.	21	1.0353	516.
8	0.0027	507.	22	1.6473	519.
9	0.0030	516.	23	2.4095	502.
10	0.0033	513.	24	3.5466	503.
11	0.0035	533.	25	4.6860	491.
12	0.0038	538.	26	5.5211	493.
13	0.0041	535.	27	6.7715	492.
14	0.0044	535.	28	9.1676	489.
			29	11.5188	484.
			30	14.3651	479.
			31	18.2092	470.
			32	22.7966	460.
			33	28.6340	453.
			34	35.7205	452.
			35	44.0568	454.

Specimen No. 6 - Step No. 8 - Initial Time = 336.492 Hours

STEP RESPONSE			RELAXATION		
	TIME (Hrs)	Ø STRAIN (Micro)		TIME (Hrs)	Ø STRAIN (Micro)
1	0.0002	10967.	16	0.0076	11845.
2	0.0005	11023.	17	0.0169	11887.
3	0.0008	11150.	18	0.0640	11823.
4	0.0010	11157.	19	0.1576	11823.
5	0.0013	11202.	20	0.3457	11812.
6	0.0016	11269.	21	0.6393	11887.
7	0.0019	11324.	22	1.0532	11812.
8	0.0024	11475.	23	1.6554	11823.
9	0.0026	11542.	24	2.2130	11834.
10	0.0029	11598.	25	2.9830	11834.
11	0.0032	11592.	26	3.8534	11836.
12	0.0035	11659.	27	4.3458	11832.
13	0.0037	11704.	28	5.8765	11854.
14	0.0040	11823.	29	7.5224	11830.
15	0.0043	11804.	30	9.1896	11830.
			31	11.2139	11799.
			32	14.1317	11801.
			33	17.8829	11801.
			34	22.4689	11808.
			35	28.4840	11817.
			36	35.9879	11815.
			37	43.8624	11801.

Specimen No. 6 - Step No. 8 - Initial Time = 336.492 Hours

STEP RESPONSE			RELAXATION		
	TIME (Hrs)	STRESS (Ksi)		TIME (Hrs)	STRESS (Ksi)
1	0.0002	15.210	16	0.0076	17.151
2	0.0005	15.355	17	0.0169	17.089
3	0.0008	15.501	18	0.0640	17.006
4	0.0010	15.688	19	0.1576	16.964
5	0.0013	15.812	20	0.3457	16.922
6	0.0016	15.958	21	0.6393	16.839
7	0.0019	16.091	22	1.0532	16.798
8	0.0024	16.319	23	1.6554	16.714
9	0.0026	16.465	24	2.2130	16.673
10	0.0029	16.590	25	2.9830	16.590
11	0.0032	16.727	26	3.8534	16.517
12	0.0035	16.872	27	4.3458	16.430
13	0.0037	16.997	28	5.8765	16.346
14	0.0040	17.121	29	7.5224	16.274
15	0.0043	17.225	30	9.1896	16.183
			31	11.2139	16.076
			32	14.1317	15.967
			33	17.8829	15.869
			34	22.4689	15.756
			35	28.4840	15.628
			36	35.9879	15.496
			37	43.8624	

Specimen No. 6 - Step No. 8 - Initial Time = 336.492 Hours

STEP RESPONSE			RELAXATION			
	TIME (Hrs)	90 STRAIN (Micro)		TIME (Hrs)	90 STRAIN (Micro)	
	1	0.0002	-9241.	16	0.0076	-9960.
	2	0.0005	-9345.	17	0.0169	-9907.
	3	0.0008	-9388.	18	0.0640	-9907.
	4	0.0010	-9381.	19	0.1576	-9907.
	5	0.0013	-9485.	20	0.3457	-9960.
	6	0.0016	-9467.	21	0.6393	-9971.
	7	0.0019	-9521.	22	1.0532	-9971.
	8	0.0024	-9636.	23	1.6554	-10035.
	9	0.0026	-9690.	24	2.2130	-9928.
	10	0.0029	-9723.	25	2.9830	-9939.
	11	0.0032	-9755.	26	3.8534	-9950.
	12	0.0035	-9799.	27	4.3458	-9951.
	13	0.0037	-9789.	28	5.8765	-9954.
	14	0.0040	-9874.	29	7.5224	-9945.
	15	0.0043	-9802.	30	9.1896	-9951.
				31	11.2139	-9947.
				32	14.1317	-9958.
				33	17.8829	-9973.
				34	22.4689	-9985.
				35	28.4840	-10001.
				36	35.9879	-10008.
				37	43.8624	-10009.

Specimen No. 6 - Step No. 8 - Initial Time = 336.492 Hours

STEP RESPONSE			RELAXATION			
	TIME (Hrs)	45 STRAIN (Micro)		TIME (Hrs)	45 STRAIN (Micro)	
	1	0.0002	457.	16	0.0076	538.
	2	0.0005	469.	17	0.0169	527.
	3	0.0008	469.	18	0.0640	527.
	4	0.0010	488.	19	0.1576	530.
	5	0.0013	480.	20	0.3457	524.
	6	0.0016	493.	21	0.6393	516.
	7	0.0019	493.	22	1.0532	513.
	8	0.0024	505.	23	1.6554	516.
	9	0.0026	513.	24	2.2130	505.
	10	0.0029	516.	25	2.9830	516.
	11	0.0032	513.	26	3.8534	509.
	12	0.0035	524.	27	4.3458	507.
	13	0.0037	522.	28	5.8765	502.
	14	0.0040	533.	29	7.5224	505.
	15	0.0043	544.	30	9.1896	502.
				31	11.2139	498.
				32	14.1317	487.
				33	17.8829	478.
				34	22.4689	474.
				35	28.4840	471.
				36	35.9879	468.
				37	43.8624	462.

Specimen No. 6 - Step No. 9 - Initial Time = 383.833 Hours

STEP RESPONSE			RELAXATION			
	TIME (Hrs)	Ø STRAIN (Micro)		TIME (Hrs)	Ø STRAIN (Micro)	
	1	0.0001	11901.	16	0.0061	12743.
	2	0.0004	11969.	17	0.0180	12743.
	3	0.0007	11960.	18	0.0422	12731.
	4	0.0009	12092.	19	0.1411	12789.
	5	0.0012	12083.	20	0.3044	12731.
	6	0.0017	12195.	21	0.7016	12800.
	7	0.0020	12262.	22	1.0358	12731.
	8	0.0023	12317.	23	1.5594	12731.
	9	0.0026	12440.	24	2.0741	12743.
	10	0.0028	12440.	25	2.6849	12743.
	11	0.0031	12496.	26	3.2511	12743.
	12	0.0034	12630.	27	4.3866	12749.
	13	0.0037	12619.	28	5.5097	12744.
	14	0.0040	12731.	29	6.9876	12750.
	15	0.0042	12708.	30	8.7979	12764.
				31	10.9326	12771.
				32	14.1480	12772.
				33	17.5524	12758.
				34	22.2945	12754.
				35	28.4755	12750.
				36	35.7323	12757.
				37	45.0674	12765.
				38	56.7383	12765.
				39	66.3250	12756.

Specimen No. 6 - Step No. 9 - Initial Time = 383.833 Hours

STEP RESPONSE			RELAXATION			
	TIME (Hrs)	STRESS (Ksi)		TIME (Hrs)	STRESS (Ksi)	
	1	0.0001	15.633	16	0.0061	17.629
	2	0.0004	15.800	17	0.0180	17.537
	3	0.0007	15.945	18	0.0422	17.504
	4	0.0009	16.070	19	0.1411	17.451
	5	0.0012	16.236	20	0.3044	17.389
	6	0.0017	16.507	21	0.7016	17.297
	7	0.0020	16.644	22	1.0358	17.255
	8	0.0023	16.789	23	1.5594	17.213
	9	0.0026	16.943	24	2.0741	17.130
	10	0.0028	17.059	25	2.6849	17.089
	11	0.0031	17.205	26	3.2511	17.014
	12	0.0034	17.359	27	4.3866	16.966
	13	0.0037	17.495	28	5.5097	16.917
	14	0.0040	17.629	29	6.9876	16.842
	15	0.0042	17.682	30	8.7979	16.751
				31	10.9326	16.647
				32	14.1480	16.519
				33	17.5524	16.410
				34	22.2945	16.306
				35	28.4755	16.217
				36	35.7323	16.109
				37	45.0674	15.988
				38	56.7383	15.840
				39	66.3250	15.745



Specimen No. 6 - Step No. 9 - Initial Time = 383.833 Hours

STEP RESPONSE			RELAXATION		
	TIME (Hrs)	90 STRAIN (Micro)		TIME (Hrs)	90 STRAIN (Micro)
1	0.0001	-10037.	16	0.0061	-10706.
2	0.0004	-10133.	17	0.0100	-10638.
3	0.0007	-10177.	18	0.0422	-10695.
4	0.0009	-10231.	19	0.1411	-10706.
5	0.0012	-10208.	20	0.3044	-10717.
6	0.0017	-10294.	21	0.7016	-10717.
7	0.0020	-10327.	22	1.0358	-10728.
8	0.0023	-10370.	23	1.5594	-10728.
9	0.0026	-10413.	24	2.0741	-10738.
10	0.0028	-10456.	25	2.6849	-10796.
11	0.0031	-10566.	26	3.2511	-10749.
12	0.0034	-10666.	27	4.3866	-10736.
13	0.0037	-10585.	28	5.5097	-10736.
14	0.0040	-10638.	29	6.9876	-10750.
15	0.0042	-10649.	30	8.7979	-10783.
			31	10.9326	-10794.
			32	14.1480	-10791.
			33	17.5524	-10807.
			34	22.2945	-1081f.
			35	28.4755	-10838.
			36	35.7323	-10839.
			37	45.0674	-10850.
			38	56.7383	-10851.
			39	66.3250	-10848.

Specimen No. 6 - Step No. 9 - Initial Time = 383.833 Hours

STEP RESPONSE			RELAXATION		
	TIME (Hrs)	45 STRAIN (Micro)		TIME (Hrs)	45 STRAIN (Micro)
1	0.0001	457.	16	0.0061	535.
2	0.0004	469.	17	0.0100	535.
3	0.0007	466.	18	0.0422	527.
4	0.0009	469.	19	0.1411	516.
5	0.0012	477.	20	0.3044	516.
6	0.0017	488.	21	0.7016	516.
7	0.0020	502.	22	1.0358	513.
8	0.0023	508.	23	1.5594	499.
9	0.0026	513.	24	2.0741	499.
10	0.0028	524.	25	2.6849	502.
11	0.0031	527.	26	3.2511	502.
12	0.0034	522.	27	4.3866	507.
13	0.0037	535.	28	5.5097	509.
14	0.0040	544.	29	6.9876	504.
15	0.0042	541.	30	8.7979	500.
			31	10.9326	493.
			32	14.1480	482.
			33	17.5524	472.
			34	22.2945	460.
			35	28.4755	456.
			36	35.7323	453.
			37	45.0674	454.
			38	56.7383	451.
			39	66.3250	450.

Specimen No. 6 - Step No. 10 - Initial Time = 453.707 Hours

STEP RESPONSE			RELAXATION		
	TIME (Hrs)	Ø STRAIN (Micro)		TIME (Hrs)	Ø STRAIN (Micro)
1	0.0006	12866.	14	0.0225	13662.
2	0.0009	12898.	15	0.0786	13736.
3	0.0012	13012.	16	0.2878	13662.
4	0.0015	13079.	17	0.6992	13736.
5	0.0018	13135.	18	1.2945	13600.
6	0.0020	13191.	19	1.7628	13685.
7	0.0023	13259.	20	2.4159	13748.
8	0.0026	13326.	21	3.2495	13748.
9	0.0029	13454.	22	4.2451	13723.
10	0.0032	13449.	23	5.5319	13709.
11	0.0034	13433.	24	6.9313	13711.
12	0.0039	13618.	25	8.9733	13728.
13	0.0042	13600.	26	10.9455	13710.
			27	14.1922	13690.
			28	18.9345	13690.
			29	21.7248	13695.
			30	28.9721	13699.
			31	34.5649	13696.
			32	43.8061	13691.

Specimen No. 6 - Step No. 10 - Initial Time = 453.707 Hours

STEP RESPONSE			RELAXATION		
	TIME (Hrs)	STRESS (Ksi)		TIME (Hrs)	STRESS (Ksi)
1	0.0006	15.904	14	0.0225	17.775
2	0.0009	16.132	15	0.0786	17.721
3	0.0012	16.278	16	0.2878	17.650
4	0.0015	16.423	17	0.6992	17.608
5	0.0018	16.569	18	1.2945	17.525
6	0.0020	16.714	19	1.7628	17.504
7	0.0023	16.860	20	2.4159	17.430
8	0.0026	17.035	21	3.2495	17.409
9	0.0029	17.151	22	4.2451	17.344
10	0.0032	17.308	23	5.5319	17.257
11	0.0034	17.463	24	6.9313	17.181
12	0.0039	17.712	25	8.9733	17.088
13	0.0042	17.849	26	10.9455	17.018
			27	14.1922	16.912
			28	18.9345	16.784
			29	21.7248	16.736
			30	28.9721	16.657
			31	34.5649	16.597
			32	43.8061	16.467

Specimen No. 6 - Step No. 10 - Initial Time = 453.707 Hours

STEP RESPONSE			RELAXATION		
	TIME (Hrs)	90 STRAIN (Micro)		TIME (Hrs)	90 STRAIN (Micro)
1	0.0006	-10896.	14	0.0225	-11549.
2	0.0009	-11008.	15	0.0786	-11611.
3	0.0012	-11062.	16	0.2878	-11622.
4	0.0015	-11036.	17	0.6992	-11570.
5	0.0018	-11090.	18	1.2945	-11570.
6	0.0020	-11192.	19	1.7628	-11570.
7	0.0023	-11176.	20	2.4159	-11654.
8	0.0026	-11289.	21	3.2495	-11592.
9	0.0029	-11394.	22	4.2451	-11604.
10	0.0032	-11365.	23	5.5319	-11613.
11	0.0034	-11408.	24	6.9313	-11637.
12	0.0039	-11484.	25	8.9733	-11651.
13	0.0042	-11466.	26	10.9455	-11649.
			27	14.1922	-11637.
			28	18.9345	-11645.
			29	21.7248	-11663.
			30	28.9721	-11684.
			31	34.5649	-11700.
			32	43.8061	-11710.

Specimen No. 6 - Step No. 10 - Initial Time = 453.707 Hours

STEP RESPONSE			RELAXATION		
	TIME (Hrs)	45 STRAIN (Micro)		TIME (Hrs)	45 STRAIN (Micro)
1	0.0006	457.	14	0.0225	527.
2	0.0009	469.	15	0.0786	505.
3	0.0012	466.	16	0.2878	513.
4	0.0015	466.	17	0.6992	516.
5	0.0018	469.	18	1.2945	513.
6	0.0020	475.	19	1.7628	505.
7	0.0023	480.	20	2.4159	491.
8	0.0026	493.	21	3.2495	488.
9	0.0029	491.	22	4.2451	491.
10	0.0032	510.	23	5.5319	489.
11	0.0034	508.	24	6.9313	486.
12	0.0039	522.	25	8.9733	484.
13	0.0042	533.	26	10.9455	482.
			27	14.1922	475.
			28	18.9345	465.
			29	21.7248	460.
			30	28.9721	452.
			31	34.5649	446.
			32	43.8061	431.

Specimen No. 6 - Step No. 11 - Initial Time = 501.828 Hours

STEP RESPONSE			RELAXATION		
	TIME (Hrs)	Ø STRAIN (Micro)		TIME (Hrs)	Ø STRAIN (Micro)
1	0.0002	13718.	16	0.0118	14549.
2	0.0005	13775.	17	0.0212	14616.
3	0.0008	13842.	18	0.0795	14605.
4	0.0011	13973.	19	0.1453	14537.
5	0.0014	14018.	20	0.2245	14605.
6	0.0018	14044.	21	0.2933	14539.
7	0.0020	14176.	22	0.3602	14531.
8	0.0023	14167.	23	0.4327	14542.
9	0.0026	14223.	24	0.5698	14564.
10	0.0029	14368.	25	0.7119	14546.
11	0.0032	14347.	26	0.8764	14537.
12	0.0034	14403.	27	1.1736	14527.
13	0.0037	14459.	28	1.4578	14537.
14	0.0040	14515.	29	1.8466	14550.
15	0.0043	14560.	30	2.2757	14545.
			31	2.8525	14547.
			32	3.6099	14554.
			33	4.2497	14564.
			34	5.5017	14563.
			35	7.2333	14599.
			36	8.4923	14613.
			37	11.3373	14664.
			38	14.4719	14674.
			39	18.2178	14675.
			40	23.2889	14661.
			41	28.2475	14665.
			42	35.9111	14679.
			43	44.5717	14694.

Specimen No. 6 - Step No. 11 - Initial Time = 501.828 Hours

STEP RESPONSE			RELAXATION		
	TIME (Hrs)	STRESS (Ksi)		TIME (Hrs)	STRESS (Ksi)
1	0.0002	16.527	16	0.0118	18.493
2	0.0005	16.673	17	0.0212	18.461
3	0.0008	16.818	18	0.0795	18.378
4	0.0011	16.973	19	0.1453	18.347
5	0.0014	17.109	20	0.2245	18.315
6	0.0018	17.338	21	0.2933	18.311
7	0.0020	17.484	22	0.3602	18.298
8	0.0023	17.629	23	0.4327	18.283
9	0.0026	17.775	24	0.5698	18.256
10	0.0029	17.920	25	0.7119	18.240
11	0.0032	18.066	26	0.8764	18.222
12	0.0034	18.202	27	1.1736	18.193
13	0.0037	18.336	28	1.4578	18.160
14	0.0040	18.451	29	1.8466	18.144
15	0.0043	18.576	30	2.2757	18.118
			31	2.8525	18.078
			32	3.6099	18.024
			33	4.2497	17.986
			34	5.5017	17.929
			35	7.2333	17.860
			36	8.4923	17.815
			37	11.3373	17.705
			38	14.4719	17.589
			39	18.2178	17.458
			40	23.2889	17.334
			41	28.2475	17.268
			42	35.9111	17.178
			43	44.5717	17.063

Specimen No. 6 - Step No. 11 - Initial Time = 501.828 Hours

STEP RESPONSE			RELAXATION		
	TIME (Hrs)	90 STRAIN (Micro)		TIME (Hrs)	90 STRAIN (Micro)
1	0.0002	-11754.	16	0.0118	-12359.
2	0.0005	-11797.	17	0.0212	-12425.
3	0.0008	-11904.	18	0.0795	-12425.
4	0.0011	-11894.	19	0.1453	-12414.
5	0.0014	-11938.	20	0.2245	-12425.
6	0.0018	-12121.	21	0.2933	-12376.
7	0.0020	-12099.	22	0.3602	-12364.
8	0.0023	-12143.	23	0.4327	-12379.
9	0.0026	-12186.	24	0.5698	-12379.
10	0.0029	-12241.	25	0.7119	-12395.
11	0.0032	-12218.	26	0.8764	-12395.
12	0.0034	-12240.	27	1.1736	-12408.
13	0.0037	-12349.	28	1.4578	-12391.
14	0.0040	-12326.	29	1.8466	-12397.
15	0.0043	-12425.	30	2.2757	-12402.
			31	2.8525	-12415.
			32	3.6099	-12427.
			33	4.2497	-12432.
			34	5.5017	-12432.
			35	7.2333	-12465.
			36	8.4923	-12470.
			37	11.3373	-12525.
			38	14.4719	-12528.
			39	18.2178	-12540.
			40	23.2889	-12549.
			41	28.2475	-12573.
			42	35.9111	-12611.
			43	44.5717	-12642.

Specimen No. 6 - Step No. 11 - Initial Time = 501.828 Hours

STEP RESPONSE			RELAXATION		
	TIME (Hrs)	45 STRAIN (Micro)		TIME (Hrs)	45 STRAIN (Micro)
1	0.0002	435.	16	0.0118	499.
2	0.0005	435.	17	0.0212	491.
3	0.0008	433.	18	0.0795	502.
4	0.0011	449.	19	0.1453	491.
5	0.0014	446.	20	0.2245	493.
6	0.0018	466.	21	0.2933	495.
7	0.0020	469.	22	0.3602	496.
8	0.0023	469.	23	0.4327	496.
9	0.0026	477.	24	0.5698	493.
10	0.0029	475.	25	0.7119	492.
11	0.0032	491.	26	0.8764	491.
12	0.0034	502.	27	1.1736	486.
13	0.0037	502.	28	1.4578	480.
14	0.0040	510.	29	1.8466	483.
15	0.0043	513.	30	2.2757	484.
			31	2.8525	482.
			32	3.6099	479.
			33	4.2497	478.
			34	5.5017	476.
			35	7.2333	471.
			36	8.4923	467.
			37	11.3373	458.
			38	14.4719	452.
			39	18.2178	443.
			40	23.2889	432.
			41	28.2475	425.
			42	35.9111	417.
			43	44.5717	407.

Specimen No. 6 - Step No. 12 - Initial Time = 550.008 Hours

STEP RESPONSE			RELAXATION			
	TIME (Hrs)	Ø STRAIN (Micro)		TIME (Hrs)	Ø STRAIN (Micro)	
	1	0.0005	14706.	15	0.0087	15507.
	2	0.0008	14774.	16	0.0262	15665.
	3	0.0010	14830.	17	0.0732	15580.
	4	0.0013	14887.	18	0.1598	15507.
	5	0.0016	14954.	19	0.2504	15580.
	6	0.0019	14930.	20	0.4344	15580.
	7	0.0022	15078.	21	0.5603	15553.
	8	0.0024	15135.	22	0.7094	15538.
	9	0.0027	15202.	23	0.8837	15505.
	10	0.0032	15293.	24	1.0469	15495.
	11	0.0034	15349.	25	1.3426	15507.
	12	0.0037	15417.	26	1.7193	15614.
	13	0.0040	15473.	27	2.2783	15564.
	14	0.0043	15529.	28	2.7441	15552.
				29	3.5162	15608.
				30	4.3679	15676.
				31	5.8609	15723.
				32	6.8563	15742.
				33	8.8534	15760.
				34	11.8692	15779.
				35	14.3936	15775.
				36	17.3356	15769.
				37	22.4258	15762.
				38	27.0310	15765.
				39	35.6131	15762.
				40	45.0346	15752.



Specimen No. 6 - Step No. 12 - Initial Time = 550.008 Hours

STEP RESPONSE

RELAXATION

STEP RESPONSE			RELAXATION		
	TIME (Hrs)	STRESS (Ksi)		TIME (Hrs)	STRESS (Ksi)
1	0.0005	17.142	15	0.0087	19.054
2	0.0008	17.308	16	0.0262	18.981
3	0.0010	17.454	17	0.0732	18.929
4	0.0013	17.599	18	0.1598	18.908
5	0.0016	17.745	19	0.2504	18.877
6	0.0019	17.890	20	0.4344	18.835
7	0.0022	18.036	21	0.5603	18.813
8	0.0024	18.202	22	0.7094	18.788
9	0.0027	18.347	23	0.8837	18.770
10	0.0032	18.586	24	1.0469	18.751
11	0.0034	18.721	25	1.3426	18.724
12	0.0037	18.867	26	1.7193	18.669
13	0.0040	19.001	27	2.2783	18.631
14	0.0043	19.127	28	2.7441	18.595
			29	3.5162	18.546
			30	4.2259	18.511
			31	4.3512	18.515
			32	4.3519	18.680
			33	4.3528	19.042
			34	4.5619	18.983
			35	5.8609	18.785
			36	6.8563	18.658
			37	8.8534	18.494
			38	11.8692	18.262
			39	14.3936	18.102
			40	17.3356	17.965
			41	22.4258	17.785
			42	27.0310	17.665
			43	35.6131	17.486
			44	45.0346	17.281

Specimen No. 6 - Step No. 12 - Initial Time = 550.000 Hours

STEP RESPONSE			RELAXATION		
	TIME (Hrs)	90 STRAIN (Micro)		TIME (Hrs)	90 STRAIN (Micro)
1	0.0005	-12664.	15	0.0087	-13251.
2	0.0008	-12651.	16	0.0262	-13262.
3	0.0010	-12683.	17	0.0732	-13333.
4	0.0013	-12737.	18	0.1598	-13218.
5	0.0016	-12769.	19	0.2504	-13229.
6	0.0019	-12892.	20	0.4344	-13229.
7	0.0022	-12856.	21	0.5603	-12166.
8	0.0024	-12910.	22	0.7094	-11818.
9	0.0027	-12953.	23	0.8837	-11587.
10	0.0032	-13170.	24	1.0469	-11536.
11	0.0034	-13072.	25	1.3426	-11488.
12	0.0037	-13115.	26	1.7193	-11480.
13	0.0040	-13229.	27	2.2783	-11203.
14	0.0043	-13262.	28	2.7441	-10756.
			29	3.5162	-10372.
			30	4.3679	-10155.
			31	5.8609	-9327.
			32	6.8563	-8828.
			33	8.8534	-7702.
			34	11.8692	-6072.
			35	14.3936	-5086.
			36	17.3356	-4506.
			37	22.4258	-4429.
			38	27.0310	-4381.
			39	35.6131	-4262.
			40	45.0346	-4151.

Specimen No. 6 - Step No. 12 - Initial Time = 550.008 Hours

STEP RESPONSE			RELAXATION		
	TIME (Hrs)	45 STRAIN (Micro)		TIME (Hrs)	45 STRAIN (Micro)
1	0.0005	415.	15	0.0087	485.
2	0.0008	426.	16	0.0262	485.
3	0.0010	426.	17	0.0732	471.
4	0.0013	435.	18	0.1598	491.
5	0.0016	437.	19	0.2504	471.
6	0.0019	446.	20	0.4344	471.
7	0.0022	455.	21	0.5603	489.
8	0.0024	457.	22	0.7094	494.
9	0.0027	469.	23	0.8837	497.
10	0.0032	469.	24	1.0469	494.
11	0.0034	482.	25	1.3426	491.
12	0.0037	480.	26	1.7193	485.
13	0.0040	480.	27	2.2783	489.
14	0.0043	491.	28	2.7441	490.
			29	3.5162	492.
			30	4.3679	494.
			31	5.8609	492.
			32	6.8563	490.
			33	8.8534	482.
			34	11.8692	475.
			35	14.3936	473.
			36	17.3356	472.
			37	22.4258	463.
			38	27.0310	458.
			39	35.6131	455.
			40	45.0346	453.

Specimen No. 7 - Step No. 1 - Initial Time = 0 Hours

STEP RESPONSE			RELAXATION		
	TIME (Hrs)	Ø STRAIN (Micro)		TIME (Hrs)	Ø STRAIN (Micro)
1	0.0007	-64.	67	0.0458	4215.
2	0.0013	-64.	68	0.0560	4190.
3	0.0018	-53.	69	0.0658	4178.
4	0.0024	37.	70	0.0821	4211.
5	0.0032	90.	71	0.1013	4223.
6	0.0040	95.	72	0.1267	4200.
7	0.0045	90.	73	0.1800	4178.
8	0.0051	101.	74	0.2473	4200.
9	0.0056	96.	75	0.3684	4190.
10	0.0063	101.	76	0.4911	4167.
11	0.0071	101.	77	0.5428	4200.
12	0.0081	112.	78	0.7867	4223.
13	0.0090	171.	79	1.0648	4189.
14	0.0097	250.	80	1.3428	4178.
15	0.0104	341.	81	1.7600	4197.
16	0.0111	437.	82	2.3163	4202.
17	0.0117	508.	83	2.8739	4197.
18	0.0122	581.	84	3.5691	4202.
19	0.0131	684.	85	4.5427	4206.
20	0.0137	753.	86	5.5170	4210.
21	0.0143	821.	87	6.6467	4215.
22	0.0149	890.	88	8.8719	4211.
23	0.0157	975.	89	11.3728	4207.
24	0.0167	1077.	90	14.1228	4202.
25	0.0177	1181.	91	17.8182	4199.
26	0.0184	1242.	92	22.4041	4201.
27	0.0189	1293.	93	28.2419	4213.
28	0.0195	1348.	94	35.7480	4219.
29	0.0201	1405.	95	46.0810	4210.
30	0.0210	1476.	96	50.9354	4233.
31	0.0217	1540.			
32	0.0222	1603.			
33	0.0228	1657.			
34	0.0233	1721.			
35	0.0240	1790.			
36	0.0246	1860.			
37	0.0252	1929.			
38	0.0257	1998.			
39	0.0263	2062.			
40	0.0269	2142.			
41	0.0276	2212.			
42	0.0281	2286.			
43	0.0287	2356.			
44	0.0292	2430.			
45	0.0299	2521.			

Specimen No. 7 - Step No. 1 - Initial Time = 0 Hours

STEP RESPONSE			RELAXATION		
	TIME (Hrs)	STRESS (Ksi)		TIME (Hrs)	STRESS (Ksi)
1	0.0007	-0.238	67	0.0458	10.778
2	0.0013	-0.227	68	0.0560	10.622
3	0.0018	-0.184	69	0.0658	10.516
4	0.0024	0.011	70	0.0821	10.473
5	0.0032	0.108	71	0.1013	10.414
6	0.0040	0.130	72	0.1267	10.371
7	0.0045	0.130	73	0.1800	10.306
8	0.0051	0.130	74	0.2473	10.241
9	0.0056	0.151	75	0.3684	10.154
10	0.0063	0.140	76	0.4911	10.166
11	0.0071	0.151	77	0.5428	10.111
12	0.0081	0.184	78	0.7867	10.090
13	0.0090	0.367	79	1.0648	10.041
14	0.0097	0.573	80	1.3428	10.003
15	0.0104	0.854	81	1.7600	9.971
16	0.0111	1.124	82	2.3163	9.931
17	0.0117	1.318	83	2.8739	9.899
18	0.0122	1.524	84	3.5691	9.865
19	0.0131	1.804	85	4.5427	9.828
20	0.0137	2.010	86	5.5170	9.797
21	0.0143	2.226	87	6.6467	9.759
22	0.0149	2.399	88	8.8719	9.706
23	0.0157	2.659	89	11.3728	9.661
24	0.0167	2.929	90	14.1228	9.630
25	0.0177	3.220	91	17.8182	9.593
26	0.0184	3.415	92	22.4041	9.561
27	0.0189	3.555	93	28.2419	9.537
28	0.0195	3.718	94	35.7480	9.506
29	0.0201	3.859	95	46.0810	9.445
30	0.0210	4.064	96	50.9354	9.377
31	0.0217	4.235			
32	0.0222	4.409			
33	0.0228	4.548			
34	0.0233	4.733			
35	0.0240	4.906			
36	0.0246	5.110			
37	0.0252	5.304			
38	0.0257	5.477			
39	0.0263	5.659			
40	0.0269	5.864			
41	0.0276	6.068			
42	0.0281	6.253			
43	0.0287	6.435			
44	0.0292	6.642			
45	0.0299	6.869			

Specimen No. 7 - Step No. 1 - Initial Time = 0 Hours

STEP RESPONSE			RELAXATION		
	TIME (Hrs)	90 STRAIN (Micro)		TIME (Hrs)	90 STRAIN (Micro)
1	0.0007	-15.	67	0.0458	-3000.
2	0.0013	0.	68	0.0560	-2990.
3	0.0018	5.	69	0.0658	-2996.
4	0.0024	-41.	70	0.0821	-2986.
5	0.0032	-66.	71	0.1013	-3012.
6	0.0040	-72.	72	0.1267	-3006.
7	0.0045	-72.	73	0.1800	-3006.
8	0.0051	-72.	74	0.2473	-3032.
9	0.0056	-82.	75	0.3684	-3058.
10	0.0063	-77.	76	0.4911	-2991.
11	0.0071	-87.	77	0.5428	-3058.
12	0.0081	-103.	78	0.7867	-3069.
13	0.0090	-149.	79	1.0648	-3037.
14	0.0097	-206.	80	1.3428	-3047.
15	0.0104	-272.	81	1.7600	-3052.
16	0.0111	-334.	82	2.3163	-3059.
17	0.0117	-388.	83	2.8739	-3065.
18	0.0122	-420.	84	3.5691	-3070.
19	0.0131	-496.	85	4.5427	-3075.
20	0.0137	-549.	86	5.5170	-3083.
21	0.0143	-598.	87	6.6467	-3084.
22	0.0149	-638.	88	8.8719	-3096.
23	0.0157	-701.	89	11.3728	-3102.
24	0.0167	-764.	90	14.1228	-3108.
25	0.0177	-841.	91	17.8182	-3110.
26	0.0184	-882.	92	22.4041	-3113.
27	0.0189	-926.	93	28.2419	-3120.
28	0.0195	-959.	94	35.7480	-3129.
29	0.0201	-998.	95	46.0810	-3139.
30	0.0210	-1044.	96	50.9354	-3146.
31	0.0217	-1090.			
32	0.0222	-1132.			
33	0.0228	-1173.			
34	0.0233	-1214.			
35	0.0240	-1263.			
36	0.0246	-1317.			
37	0.0252	-1354.			
38	0.0257	-1395.			
39	0.0263	-1450.			
40	0.0269	-1498.			
41	0.0276	-1549.			
42	0.0281	-1595.			
43	0.0287	-1647.			
44	0.0292	-1694.			
45	0.0299	-1745.			

Specimen No. 7 - Step No. 1 - Initial Time = 0 Hours

STEP RESPONSE			RELAXATION		
	TIME (Hrs)	45 STRAIN (Micro)		TIME (Hrs)	45 STRAIN (Micro)
1	0.0007	-17.	67	0.0458	455.
2	0.0013	-17.	68	0.0560	447.
3	0.0018	-6.	69	0.0658	438.
4	0.0024	16.	70	0.0821	451.
5	0.0032	27.	71	0.1013	438.
6	0.0040	33.	72	0.1267	438.
7	0.0045	28.	73	0.1800	429.
8	0.0051	27.	74	0.2473	429.
9	0.0056	22.	75	0.3684	418.
10	0.0063	27.	76	0.4911	446.
11	0.0071	22.	77	0.5428	418.
12	0.0081	22.	78	0.7867	418.
13	0.0090	28.	79	1.0648	427.
14	0.0097	33.	80	1.3428	416.
15	0.0104	55.	81	1.7600	419.
16	0.0111	66.	82	2.3163	419.
17	0.0117	72.	83	2.8739	415.
18	0.0122	82.	84	3.5691	414.
19	0.0131	93.	85	4.5427	414.
20	0.0137	104.	86	5.5170	414.
21	0.0143	121.	87	6.6467	412.
22	0.0149	121.	88	8.8719	407.
23	0.0157	132.	89	11.3728	403.
24	0.0167	138.	90	14.1228	399.
25	0.0177	154.	91	17.8182	394.
26	0.0184	165.	92	22.4041	393.
27	0.0189	165.	93	28.2419	393.
28	0.0195	171.	94	35.7480	391.
29	0.0201	176.	95	46.0810	381.
30	0.0210	187.	96	50.9354	363.
31	0.0217	198.			
32	0.0222	203.			
33	0.0228	209.			
34	0.0233	221.			
35	0.0240	226.			
36	0.0246	237.			
37	0.0252	242.			
38	0.0257	253.			
39	0.0263	258.			
40	0.0269	263.			
41	0.0276	274.			
42	0.0281	280.			
43	0.0287	286.			
44	0.0292	291.			
45	0.0299	312.			

Specimen No. 7 - Step No. 2 - Initial Time = 51.449 Hours

STEP RESPONSE			RELAXATION		
	TIME (Hrs)	Ø STRAIN (Micro)		TIME (Hrs)	Ø STRAIN (Micro)
1	0.0004	4253.	29	0.0107	5615.
2	0.0007	4306.	30	0.0154	5625.
3	0.0010	4359.	31	0.0243	5596.
4	0.0014	4423.	32	0.0352	5625.
5	0.0017	4466.	33	0.0604	5615.
6	0.0019	4509.	34	0.1009	5644.
7	0.0022	4575.	35	0.1814	5625.
8	0.0025	4618.	36	0.2695	5625.
9	0.0028	4672.	37	0.3862	5655.
10	0.0030	4700.	38	0.6170	5625.
11	0.0033	4718.	39	0.9448	5636.
12	0.0036	4786.	40	1.3564	5647.
13	0.0039	4854.	41	1.9314	5647.
14	0.0044	4924.	42	2.9086	5667.
15	0.0047	4982.	43	3.4212	5676.
16	0.0050	5036.	44	4.3161	5684.
17	0.0053	5052.	45	5.6473	5690.
18	0.0055	5095.	46	6.9666	5694.
19	0.0058	5148.	47	8.4899	5689.
20	0.0061	5191.	48	11.2977	5681.
21	0.0064	5244.	49	14.2155	5674.
22	0.0066	5315.	50	18.0400	5676.
23	0.0069	5329.	51	22.6471	5687.
24	0.0074	5432.	52	28.4825	5697.
25	0.0077	5475.	53	35.9852	5701.
26	0.0079	5529.	54	44.7383	5694.
27	0.0082	5542.			
28	0.0085	5625.			



Specimen No. 7 - Step No. 2 - Initial Time = 51.449 Hours

STEP RESPONSE			RELAXATION		
	TIME (Hrs)	STRESS (Ksi)		TIME (Hrs)	STRESS (Ksi)
1	0.0004	9.588	29	0.0107	13.086
2	0.0007	9.717	30	0.0154	13.043
3	0.0010	9.868	31	0.0243	12.956
4	0.0014	10.068	32	0.0352	12.898
5	0.0017	10.192	33	0.0604	12.834
6	0.0019	10.306	34	0.1009	12.747
7	0.0022	10.414	35	0.1814	12.704
8	0.0025	10.543	36	0.2695	12.611
9	0.0028	10.689	37	0.3862	12.574
10	0.0030	10.819	38	0.6170	12.503
11	0.0033	10.948	39	0.9448	12.423
12	0.0036	11.078	40	1.3564	12.401
13	0.0039	11.207	41	1.9314	12.315
14	0.0044	11.429	42	2.9086	12.295
15	0.0047	11.553	43	3.4212	12.272
16	0.0050	11.682	44	4.3161	12.236
17	0.0053	11.775	45	5.6473	12.180
18	0.0055	11.898	46	6.9666	12.131
19	0.0058	12.028	47	8.4899	12.080
20	0.0061	12.136	48	11.2977	12.004
21	0.0064	12.272	49	14.2155	11.950
22	0.0066	12.395	50	18.0400	11.890
23	0.0069	12.503	51	22.6471	11.859
24	0.0074	12.704	52	28.4825	11.810
25	0.0077	12.834	53	35.9852	11.759
26	0.0079	12.935	54	44.7383	11.691
27	0.0082	13.064			
28	0.0085	13.166			

Specimen No. 7 - Step No. 2 - Initial Time = 51.449 Hours

STEP RESPONSE			RELAXATION		
	TIME (Hrs)	90 STRAIN (Micro)		TIME (Hrs)	90 STRAIN (Micro)
1	0.0004	-3187.	29	0.0107	-4136.
2	0.0007	-3201.	30	0.0154	-4114.
3	0.0010	-3249.	31	0.0243	-4146.
4	0.0014	-3266.	32	0.0352	-4156.
5	0.0017	-3342.	33	0.0604	-4167.
6	0.0019	-3373.	34	0.1009	-4177.
7	0.0022	-3403.	35	0.1814	-4177.
8	0.0025	-3406.	36	0.2695	-4187.
9	0.0028	-3455.	37	0.3862	-4220.
10	0.0030	-3486.	38	0.6170	-4230.
11	0.0033	-3488.	39	0.9448	-4218.
12	0.0036	-3540.	40	1.3564	-4251.
13	0.0039	-3571.	41	1.9314	-4261.
14	0.0044	-3632.	42	2.9086	-4232.
15	0.0047	-3682.	43	3.4212	-4237.
16	0.0050	-3713.	44	4.3161	-4245.
17	0.0053	-3724.	45	5.6473	-4257.
18	0.0055	-3755.	46	6.9666	-4266.
19	0.0058	-3776.	47	8.4899	-4274.
20	0.0061	-3817.	48	11.2977	-4284.
21	0.0064	-3878.	49	14.2155	-4282.
22	0.0066	-3909.	50	18.0400	-4291.
23	0.0069	-3919.	51	22.6471	-4298.
24	0.0074	-3991.	52	28.4825	-4312.
25	0.0077	-4054.	53	35.9852	-4326.
26	0.0079	-4064.	54	44.7383	-4339.
27	0.0082	-4073.			
28	0.0085	-4104.			

Specimen No. 7 - Step No. 2 - Initial Time = 51.449 Hours

STEP RESPONSE			RELAXATION		
	TIME (Hrs)	45 STRAIN (Micro)		TIME (Hrs)	45 STRAIN (Micro)
1	0.0004	383.	29	0.0107	528.
2	0.0007	394.	30	0.0154	525.
3	0.0010	394.	31	0.0243	525.
4	0.0014	405.	32	0.0352	514.
5	0.0017	416.	33	0.0604	506.
6	0.0019	407.	34	0.1009	506.
7	0.0022	418.	35	0.1814	506.
8	0.0025	429.	36	0.2695	506.
9	0.0028	438.	37	0.3862	495.
10	0.0030	449.	38	0.6170	506.
11	0.0033	449.	39	0.9448	495.
12	0.0036	459.	40	1.3564	495.
13	0.0039	449.	41	1.9314	484.
14	0.0044	459.	42	2.9086	501.
15	0.0047	459.	43	3.4212	496.
16	0.0050	470.	44	4.3161	497.
17	0.0053	470.	45	5.6473	497.
18	0.0055	481.	46	6.9666	496.
19	0.0058	492.	47	8.4899	491.
20	0.0061	492.	48	11.2977	484.
21	0.0064	506.	49	14.2155	478.
22	0.0066	503.	50	18.0400	473.
23	0.0069	514.	51	22.6471	474.
24	0.0074	514.	52	28.4825	475.
25	0.0077	517.	53	35.9852	470.
26	0.0079	525.	54	44.7383	459.
27	0.0082	525.			
28	0.0085	536.			

Specimen No. 7 - Step No. 3 - Initial Time = 100.588 Hours

STEP RESPONSE

RELAXATION

STEP RESPONSE			RELAXATION		
	TIME (Hrs)	Ø STRAIN (Micro)		TIME (Hrs)	Ø STRAIN (Micro)
1	0.0000	5732.	30	0.0114	7181.
2	0.0003	5736.	31	0.0156	7153.
3	0.0007	5861.	32	0.0238	7115.
4	0.0010	5915.	33	0.0377	7115.
5	0.0013	5968.	34	0.0563	7125.
6	0.0015	6054.	35	0.0811	7125.
7	0.0018	6086.	36	0.1250	7163.
8	0.0021	6107.	37	0.1680	7125.
9	0.0024	6183.	38	0.2422	7163.
10	0.0026	6193.	39	0.3625	7136.
11	0.0029	6269.	40	0.4463	7152.
12	0.0032	6323.	41	0.5613	7185.
13	0.0038	6386.	42	0.8396	7196.
14	0.0041	6474.	43	1.0810	7196.
15	0.0043	6506.	44	1.5305	7168.
16	0.0046	6560.	45	1.8319	7245.
17	0.0049	6568.	46	2.5013	7217.
18	0.0052	6657.	47	3.1174	7217.
19	0.0055	6700.	48	3.5701	7218.
20	0.0057	6754.	49	4.6072	7223.
21	0.0060	6761.	50	5.5004	7200.
22	0.0063	6851.	51	6.8424	7214.
23	0.0067	6890.	52	9.1019	7219.
24	0.0070	6933.	53	11.5635	7217.
25	0.0073	6975.	54	14.2626	7210.
26	0.0075	7018.	55	17.9423	7204.
27	0.0078	7061.	56	22.5277	7206.
28	0.0081	7115.	57	28.3685	7219.
29	0.0084	7158.	58	35.8711	7222.
			59	43.7947	7219.

Specimen No. 7 - Step No. 3 - Initial Time = 100.588 Hours

STEP RESPONSE			RELAXATION		
	TIME (Hrs)	STRESS (Ksi)		TIME (Hrs)	STRESS (Ksi)
1	0.0000	11.790	30	0.0114	15.406
2	0.0003	11.942	31	0.0156	15.245
3	0.0007	12.142	32	0.0238	15.210
4	0.0010	12.293	33	0.0377	15.116
5	0.0013	12.438	34	0.0563	15.094
6	0.0015	12.568	35	0.0811	15.008
7	0.0018	12.711	36	0.1250	14.965
8	0.0021	12.812	37	0.1680	14.878
9	0.0024	12.942	38	0.2422	14.835
10	0.0026	13.071	39	0.3625	14.749
11	0.0029	13.201	40	0.4463	14.722
12	0.0032	13.309	41	0.5613	14.670
13	0.0038	13.590	42	0.8396	14.584
14	0.0041	13.712	43	1.0810	14.540
15	0.0043	13.799	44	1.5305	14.446
16	0.0046	13.935	45	1.8319	14.411
17	0.0049	14.065	46	2.5013	14.346
18	0.0052	14.195	47	3.1174	14.310
19	0.0055	14.317	48	3.5701	14.265
20	0.0057	14.432	49	4.6072	14.183
21	0.0060	14.576	50	5.5004	14.108
22	0.0063	14.698	51	6.8424	14.043
23	0.0067	14.857	52	9.1019	13.947
24	0.0070	14.965	53	11.5635	13.862
25	0.0073	15.094	54	14.2626	13.786
26	0.0075	15.202	55	17.9423	13.711
27	0.0078	15.310	56	22.5277	13.648
28	0.0081	15.418	57	28.3685	13.579
29	0.0084	15.534	58	35.8711	13.490
			59	43.7947	13.396

Specimen No. 7 - Step No. 3 - Initial Time = 100.588 Hours

STEP RESPONSE			RELAXATION		
	TIME (Hrs)	90 STRAIN (Micro)		TIME (Hrs)	90 STRAIN (Micro)
1	0.0000	-4340.	30	0.0114	-5369.
2	0.0003	-4391.	31	0.0156	-5353.
3	0.0007	-4455.	32	0.0238	-5353.
4	0.0010	-4497.	33	0.0377	-5363.
5	0.0013	-4538.	34	0.0563	-5363.
6	0.0015	-4569.	35	0.0811	-5373.
7	0.0018	-4624.	36	0.1250	-5384.
8	0.0021	-4655.	37	0.1680	-5394.
9	0.0024	-4696.	38	0.2422	-5433.
10	0.0026	-4703.	39	0.3625	-5415.
11	0.0029	-4734.	40	0.4463	-5421.
12	0.0032	-4765.	41	0.5613	-5435.
13	0.0038	-4827.	42	0.8396	-5446.
14	0.0041	-4858.	43	1.0810	-5484.
15	0.0043	-4925.	44	1.5305	-5466.
16	0.0046	-4930.	45	1.8319	-5516.
17	0.0049	-4961.	46	2.5013	-5497.
18	0.0052	-4992.	47	3.1174	-5536.
19	0.0055	-5049.	48	3.5701	-5506.
20	0.0057	-5054.	49	4.6072	-5498.
21	0.0060	-5095.	50	5.5004	-5547.
22	0.0063	-5089.	51	6.8424	-5525.
23	0.0067	-5140.	52	9.1019	-5524.
24	0.0070	-5198.	53	11.5635	-5537.
25	0.0073	-5229.	54	14.2626	-5544.
26	0.0075	-5233.	55	17.9423	-5551.
27	0.0078	-5301.	56	22.5277	-5548.
28	0.0081	-5332.	57	28.3685	-5551.
29	0.0084	-5373.	58	35.8711	-5564.
			59	43.7947	-5582.

Specimen No. 7 - Step No. 3 - Initial Time = 100.588 Hours

STEP RESPONSE			RELAXATION		
	TIME (Hrs)	45 STRAIN (Micro)		TIME (Hrs)	45 STRAIN (Micro)
1	0.0000	459.	30	0.0114	610.
2	0.0003	470.	31	0.0156	616.
3	0.0007	481.	32	0.0238	602.
4	0.0010	481.	33	0.0377	591.
5	0.0013	481.	34	0.0563	602.
6	0.0015	503.	35	0.0811	602.
7	0.0018	495.	36	0.1250	591.
8	0.0021	495.	37	0.1680	594.
9	0.0024	514.	38	0.2422	583.
10	0.0026	506.	39	0.3625	580.
11	0.0029	517.	40	0.4463	581.
12	0.0032	525.	41	0.5613	572.
13	0.0038	536.	42	0.8396	569.
14	0.0041	536.	43	1.0810	569.
15	0.0043	539.	44	1.5305	569.
16	0.0046	550.	45	1.8319	561.
17	0.0049	550.	46	2.5013	561.
18	0.0052	561.	47	3.1174	550.
19	0.0055	561.	48	3.5701	558.
20	0.0057	572.	49	4.6072	558.
21	0.0060	569.	50	5.5004	550.
22	0.0063	588.	51	6.8424	551.
23	0.0067	591.	52	9.1019	551.
24	0.0070	591.	53	11.5635	546.
25	0.0073	602.	54	14.2626	543.
26	0.0075	602.	55	17.9423	539.
27	0.0078	602.	56	22.5277	541.
28	0.0081	613.	57	28.3685	541.
29	0.0084	613.	58	35.8711	538.
			59	43.7947	530.

Specimen No. 7 - Step No. 4 - Initial Time = 148.224 Hours

STEP RESPONSE			RELAXATION		
	TIME (Hrs)	Ø STRAIN (Micro)		TIME (Hrs)	Ø STRAIN (Micro)
1	0.0006	7254.	15	0.0089	7982.
2	0.0009	7308.	16	0.0330	7982.
3	0.0011	7361.	17	0.1590	7993.
4	0.0014	7386.	18	0.4031	8035.
5	0.0017	7479.	19	0.8401	7961.
6	0.0020	7533.	20	1.5712	7983.
7	0.0025	7670.	21	2.0468	8014.
8	0.0027	7723.	22	2.9007	7998.
9	0.0030	7725.	23	3.8793	8036.
10	0.0033	7810.	24	4.6960	8036.
11	0.0036	7895.	25	5.5296	8004.
12	0.0039	7865.	26	6.7509	8017.
13	0.0041	7908.	27	8.8055	8006.
14	0.0044	7961.	28	11.3063	7993.
			29	14.2241	7988.
			30	17.9769	7988.
			31	22.5635	7996.
			32	28.3996	8008.
			33	35.9023	8017.
			34	45.0075	8019.

Specimen No. 7 - Step No. 4 - Initial Time = 148.224 Hours

STEP RESPONSE			RELAXATION		
	TIME (Hrs)	STRESS (Ksi)		TIME (Hrs)	STRESS (Ksi)
1	0.0006	13.503	15	0.0089	15.353
2	0.0009	13.669	16	0.0330	15.275
3	0.0011	13.799	17	0.1590	15.224
4	0.0014	13.971	18	0.4031	15.189
5	0.0017	14.130	19	0.8401	15.102
6	0.0020	14.274	20	1.5712	15.086
7	0.0025	14.511	21	2.0468	15.037
8	0.0027	14.662	22	2.9007	15.004
9	0.0030	14.770	23	3.8793	14.965
10	0.0033	14.900	24	4.6960	14.908
11	0.0036	15.029	25	5.5296	14.878
12	0.0039	15.159	26	6.7509	14.812
13	0.0041	15.267	27	8.8055	14.729
14	0.0044	15.397	28	11.3063	14.651
			29	14.2241	14.579
			30	17.9769	14.499
			31	22.5635	14.418
			32	28.3996	14.316
			33	35.9023	14.197
			34	45.0075	14.067



Specimen No. 7 - Step No. 4 - Initial Time = 148.224 Hours

STEP RESPONSE			RELAXATION		
	TIME (Hrs)	90 STRAIN (Micro)		TIME (Hrs)	90 STRAIN (Micro)
1	0.0006	-5650.	15	0.0089	-6127.
2	0.0009	-5652.	16	0.0330	-6138.
3	0.0011	-5703.	17	0.1590	-6106.
4	0.0014	-5734.	18	0.4031	-6116.
5	0.0017	-5765.	19	0.8401	-6126.
6	0.0020	-5817.	20	1.5712	-6053.
7	0.0025	-5899.	21	2.0468	-6169.
8	0.0027	-5910.	22	2.9007	-6134.
9	0.0030	-5941.	23	3.8793	-6115.
10	0.0033	-5972.	24	4.6960	-6189.
11	0.0036	-6044.	25	5.5296	-6125.
12	0.0039	-6033.	26	6.7509	-6133.
13	0.0041	-6064.	27	8.8055	-6140.
14	0.0044	-6095.	28	11.3063	-6156.
			29	14.2241	-6180.
			30	17.9769	-6198.
			31	22.5635	-6201.
			32	28.3996	-6199.
			33	35.9023	-6211.
			34	45.0075	-6241.

Specimen No. 7 - Step No. 4 - Initial Time = 148.224 Hours

STEP RESPONSE			RELAXATION		
	TIME (Hrs)	45 STRAIN (Micro)		TIME (Hrs)	45 STRAIN (Micro)
1	0.0006	536.	15	0.0089	613.
2	0.0009	547.	16	0.0330	605.
3	0.0011	547.	17	0.1590	616.
4	0.0014	558.	18	0.4031	605.
5	0.0017	569.	19	0.8401	602.
6	0.0020	569.	20	1.5712	617.
7	0.0025	580.	21	2.0468	602.
8	0.0027	591.	22	2.9007	602.
9	0.0030	591.	23	3.8793	599.
10	0.0033	602.	24	4.6960	602.
11	0.0036	602.	25	5.5296	609.
12	0.0039	602.	26	6.7509	600.
13	0.0041	613.	27	8.8055	592.
14	0.0044	620.	28	11.3063	585.
			29	14.2241	576.
			30	17.9769	570.
			31	22.5635	571.
			32	28.3996	577.
			33	35.9023	576.
			34	45.0075	568.

Specimen No. 7 - Step No. 5 - Initial Time = 197.091 Hours

STEP RESPONSE			RELAXATION		
	TIME (Hrs)	Ø STRAIN (Micro)		TIME (Hrs)	Ø STRAIN (Micro)
1	0.0003	8090.	15	0.0101	8775.
2	0.0006	8133.	16	0.0328	8811.
3	0.0009	8186.	17	0.1126	8822.
4	0.0012	8250.	18	0.2543	8822.
5	0.0015	8304.	19	0.5465	8822.
6	0.0017	8368.	20	0.9706	8822.
7	0.0020	8411.	21	1.4755	8833.
8	0.0026	8518.	22	2.1903	8793.
9	0.0028	8561.	23	2.7197	8844.
10	0.0031	8615.	24	3.4966	8844.
11	0.0034	8636.	25	4.4849	8838.
12	0.0037	8736.	26	5.9308	8832.
13	0.0039	8743.	27	6.7129	8823.
14	0.0042	8786.	28	8.9434	8817.
			29	11.1807	8821.
			30	13.9666	8833.
			31	17.2841	8832.
			32	22.5394	8838.
			33	28.3758	8844.
			34	35.8785	8843.

Specimen No. 7 - Step No. 5 - Initial Time = 197.091 Hours

STEP RESPONSE			RELAXATION		
	TIME (Hrs)	STRESS (Ksi)		TIME (Hrs)	STRESS (Ksi)
1	0.0003	14.252	15	0.0101	16.088
2	0.0006	14.403	16	0.0328	16.023
3	0.0009	14.554	17	0.1126	15.958
4	0.0012	14.706	18	0.2543	15.901
5	0.0015	14.878	19	0.5465	15.858
6	0.0017	15.008	20	0.9706	15.772
7	0.0020	15.159	21	1.4755	15.742
8	0.0026	15.440	22	2.1903	15.688
9	0.0028	15.548	23	2.7197	15.613
10	0.0031	15.677	24	3.4966	15.577
11	0.0034	15.785	25	4.4849	15.511
12	0.0037	15.893	26	5.9308	15.439
13	0.0039	16.023	27	6.7129	15.404
14	0.0042	16.152	28	8.9434	15.311
			29	11.1807	15.229
			30	13.9666	15.147
			31	17.2841	15.075
			32	22.5394	14.998
			33	28.3758	14.912
			34	35.8785	14.806

Specimen No. 7 - Step No. 5 - Initial Time = 197.091 Hours

STEP RESPONSE			RELAXATION		
	TIME (Hrs)	90 STRAIN (Micro)		TIME (Hrs)	90 STRAIN (Micro)
1	0.0003	-6248.	15	0.0101	-6766.
2	0.0006	-6322.	16	0.0328	-6766.
3	0.0009	-6330.	17	0.1126	-6776.
4	0.0012	-6372.	18	0.2543	-6822.
5	0.0015	-6436.	19	0.5465	-6786.
6	0.0017	-6443.	20	0.9706	-6797.
7	0.0020	-6518.	21	1.4755	-6843.
8	0.0026	-6546.	22	2.1903	-6798.
9	0.0028	-6577.	23	2.7197	-6863.
10	0.0031	-6677.	24	3.4966	-6828.
11	0.0034	-6673.	25	4.4849	-6829.
12	0.0037	-6704.	26	5.9308	-6826.
13	0.0039	-6735.	27	6.7129	-6830.
14	0.0042	-6811.	28	8.9434	-6843.
			29	11.1807	-6859.
			30	13.9666	-6868.
			31	17.2841	-6878.
			32	22.5394	-6890.
			33	28.3758	-6909.
			34	35.8785	-6927.

Specimen No. 7 - Step No. 5 - Initial Time = 197.091 Hours

STEP RESPONSE			RELAXATION		
	TIME (Hrs)	45 STRAIN (Micro)		TIME (Hrs)	45 STRAIN (Micro)
1	0.0003	591.	15	0.0101	656.
2	0.0006	588.	16	0.0328	645.
3	0.0009	602.	17	0.1126	656.
4	0.0012	599.	18	0.2543	645.
5	0.0015	609.	19	0.5465	635.
6	0.0017	620.	20	0.9706	645.
7	0.0020	620.	21	1.4755	645.
8	0.0026	631.	22	2.1903	644.
9	0.0028	642.	23	2.7197	645.
10	0.0031	642.	24	3.4966	635.
11	0.0034	653.	25	4.4849	634.
12	0.0037	645.	26	5.9308	630.
13	0.0039	656.	27	6.7129	629.
14	0.0042	656.	28	8.9434	621.
			29	11.1807	618.
			30	13.9666	610.
			31	17.2841	606.
			32	22.5394	601.
			33	28.3758	596.
			34	35.8785	589.

Specimen No. 7 - Step No. 6 - Initial Time = 237.231 Hours

STEP RESPONSE			RELAXATION		
	TIME (Hrs)	Ø STRAIN (Micro)		TIME (Hrs)	Ø STRAIN (Micro)
1	0.0001	8919.	16	0.0064	9630.
2	0.0004	8973.	17	0.0167	9619.
3	0.0007	8979.	18	0.0639	9619.
4	0.0010	9033.	19	0.1589	9660.
5	0.0014	9129.	20	0.3812	9619.
6	0.0016	9172.	21	0.8198	9619.
7	0.0019	9275.	22	1.2451	9660.
8	0.0022	9290.	23	1.9669	9612.
9	0.0025	9333.	24	1.9957	9619.
10	0.0028	9425.	25	2.7204	9630.
11	0.0030	9479.	26	3.3504	9630.
12	0.0033	9522.	27	4.4870	9635.
13	0.0036	9526.	28	5.7065	9652.
14	0.0039	9609.	29	6.9570	9647.
15	0.0042	9590.	30	9.0410	9667.
			31	11.5230	9677.
			32	14.4406	9669.
			33	18.1919	9659.
			34	22.2552	9662.
			35	28.0868	9670.
			36	35.8780	9674.
			37	45.0878	9672.
			38	50.4193	9654.

Specimen No. 7 - Step No. 6 - Initial Time = 237.231 Hours

STEP RESPONSE			RELAXATION		
	TIME (Hrs)	STRESS (Ksi)		TIME (Hrs)	STRESS (Ksi)
1	0.0001	14.929	16	0.0064	16.822
2	0.0004	15.073	17	0.0167	16.766
3	0.0007	15.224	18	0.0639	16.714
4	0.0010	15.383	19	0.1589	16.636
5	0.0014	15.613	20	0.3812	16.593
6	0.0016	15.764	21	0.8198	16.528
7	0.0019	15.915	22	1.2451	16.442
8	0.0022	16.066	23	1.9669	16.405
9	0.0025	16.187	24	1.9957	16.398
10	0.0028	16.325	25	2.7204	16.312
11	0.0030	16.433	26	3.3504	16.282
12	0.0033	16.541	27	4.4870	16.212
13	0.0036	16.692	28	5.7065	16.152
14	0.0039	16.800	29	6.9570	16.097
15	0.0042	16.878	30	9.0410	16.031
			31	11.5230	15.947
			32	14.4406	15.844
			33	18.1919	15.712
			34	22.2552	15.607
			35	28.0868	15.510
			36	35.8780	15.405
			37	45.0878	15.291
			38	50.4193	15.234

Specimen No. 7 - Step No. 6 - Initial Time = 237.231 Hours

STEP RESPONSE			RELAXATION		
	TIME (Hrs)	90 STRAIN (Micro)		TIME (Hrs)	90 STRAIN (Micro)
1	0.0001	-6982.	16	0.0064	-7506.
2	0.0004	-7024.	17	0.0167	-7506.
3	0.0007	-7018.	18	0.0639	-7506.
4	0.0010	-7096.	19	0.1589	-7516.
5	0.0014	-7110.	20	0.3812	-7477.
6	0.0016	-7189.	21	0.8198	-7527.
7	0.0019	-7219.	22	1.2451	-7537.
8	0.0022	-7223.	23	1.9669	-7494.
9	0.0025	-7292.	24	1.9957	-7537.
10	0.0028	-7371.	25	2.7204	-7548.
11	0.0030	-7364.	26	3.3504	-7508.
12	0.0033	-7434.	27	4.4870	-7550.
13	0.0036	-7415.	28	5.7065	-7529.
14	0.0039	-7408.	29	6.9570	-7534.
15	0.0042	-7506.	30	9.0410	-7543.
			31	11.5230	-7553.
			32	14.4406	-7553.
			33	18.1919	-7567.
			34	22.2552	-7578.
			35	28.0868	-7602.
			36	35.8780	-7616.
			37	45.0878	-7633.
			38	50.4193	-7642.

Specimen No. 7 - Step No. 6 - Initial Time = 237.231 Hours

STEP RESPONSE			RELAXATION		
	TIME (Hrs)	45 STRAIN (Micro)		TIME (Hrs)	45 STRAIN (Micro)
1	0.0001	591.	16	0.0064	667.
2	0.0004	591.	17	0.0167	656.
3	0.0007	602.	18	0.0639	656.
4	0.0010	613.	19	0.1589	656.
5	0.0014	620.	20	0.3812	656.
6	0.0016	624.	21	0.8198	656.
7	0.0019	631.	22	1.2451	645.
8	0.0022	642.	23	1.9669	650.
9	0.0025	635.	24	1.9957	645.
10	0.0028	645.	25	2.7204	635.
11	0.0030	645.	26	3.3504	635.
12	0.0033	660.	27	4.4870	637.
13	0.0036	664.	28	5.7065	645.
14	0.0039	664.	29	6.9570	640.
15	0.0042	667.	30	9.0410	640.
			31	11.5230	639.
			32	14.4406	637.
			33	18.1919	628.
			34	22.2552	622.
			35	28.0868	616.
			36	35.8780	613.
			37	45.0878	608.
			38	50.4193	604.

Specimen No. 7 - Step No. 7 - Initial Time = 288.177 Hours

STEP RESPONSE			RELAXATION		
	TIME (Hrs)	Ø STRAIN (Micro)		TIME (Hrs)	Ø STRAIN (Micro)
1	0.0006	9729.	15	0.0087	10492.
2	0.0009	9835.	16	0.0317	10481.
3	0.0011	9941.	17	0.1184	10537.
4	0.0014	9942.	18	0.3062	10492.
5	0.0019	10039.	19	0.5134	10481.
6	0.0022	10093.	20	0.9631	10537.
7	0.0024	10147.	21	1.0353	10492.
8	0.0027	10201.	22	1.6473	10548.
9	0.0030	10255.	23	2.4095	10559.
10	0.0033	10254.	24	3.5466	10497.
11	0.0035	10318.	25	4.6860	10513.
12	0.0038	10361.	26	5.5211	10580.
13	0.0041	10404.	27	6.7715	10546.
14	0.0044	10447.	28	9.1676	10512.
			29	11.5188	10507.
			30	14.3651	10507.
			31	18.2092	10516.
			32	22.7966	10524.
			33	28.6340	10524.
			34	35.7205	10528.
			35	44.0568	10524.

Specimen No. 7 - Step No. 7 - Initial Time = 288.177 Hours

STEP RESPONSE			RELAXATION		
	TIME (Hrs)	STRESS (Ksi)		TIME (Hrs)	STRESS (Ksi)
1	0.0006	15.453	15	0.0087	17.362
2	0.0009	15.634	16	0.0317	17.297
3	0.0011	15.793	17	0.1184	17.232
4	0.0014	15.923	18	0.3062	17.146
5	0.0019	16.174	19	0.5134	17.124
6	0.0022	16.325	20	0.9631	17.068
7	0.0024	16.476	21	1.0353	17.059
8	0.0027	16.636	22	1.6473	17.016
9	0.0030	16.779	23	2.4095	16.939
10	0.0033	16.908	24	3.5466	16.892
11	0.0035	17.050	25	4.6860	16.852
12	0.0038	17.202	26	5.5211	16.800
13	0.0041	17.309	27	6.7715	16.747
14	0.0044	17.426	28	9.1676	16.642
			29	11.5188	16.549
			30	14.3651	16.444
			31	18.2092	16.341
			32	22.7966	16.261
			33	28.6340	16.171
			34	35.7205	16.057
			35	44.0568	15.910

Specimen No. 7 - Step No. 7 - Initial Time = 288.177 Hours

STEP RESPONSE			RELAXATION		
	TIME (Hrs)	90 STRAIN (Micro)		TIME (Hrs)	90 STRAIN (Micro)
1	0.0006	-7704.	15	0.0087	-8189.
2	0.0009	-7745.	16	0.0317	-8189.
3	0.0011	-7787.	17	0.1184	-8242.
4	0.0014	-7859.	18	0.3062	-8199.
5	0.0019	-7839.	19	0.5134	-8199.
6	0.0022	-7921.	20	0.9631	-8263.
7	0.0024	-8004.	21	1.0353	-8210.
8	0.0027	-8035.	22	1.6473	-8273.
9	0.0030	-8034.	23	2.4095	-8241.
10	0.0033	-8065.	24	3.5466	-8265.
11	0.0035	-8054.	25	4.6860	-8261.
12	0.0038	-8085.	26	5.5211	-8271.
13	0.0041	-8158.	27	6.7715	-8274.
14	0.0044	-8189.	28	9.1676	-8271.
			29	11.5188	-8276.
			30	14.3651	-8297.
			31	18.2092	-8318.
			32	22.7966	-8344.
			33	28.6340	-8353.
			34	35.7205	-8359.
			35	44.0568	-8355.

Specimen No. 7 - Step No. 7 - Initial Time = 288.177 Hours

STEP RESPONSE			RELAXATION		
	TIME (Hrs)	45 STRAIN (Micro)		TIME (Hrs)	45 STRAIN (Micro)
1	0.0006	609.	15	0.0087	686.
2	0.0009	624.	16	0.0317	678.
3	0.0011	624.	17	0.1184	689.
4	0.0014	631.	18	0.3062	686.
5	0.0019	642.	19	0.5134	675.
6	0.0022	642.	20	0.9631	667.
7	0.0024	653.	21	1.0353	675.
8	0.0027	664.	22	1.6473	664.
9	0.0030	664.	23	2.4095	664.
10	0.0033	675.	24	3.5466	665.
11	0.0035	682.	25	4.6860	653.
12	0.0038	682.	26	5.5211	653.
13	0.0041	686.	27	6.7715	654.
14	0.0044	696.	28	9.1676	654.
			29	11.5188	648.
			30	14.3651	640.
			31	18.2092	629.
			32	22.7966	620.
			33	28.6340	615.
			34	35.7205	615.
			35	44.0568	621.

Specimen No. 7 - Step No. 8 - Initial Time = 336.492 Hours

STEP RESPONSE			RELAXATION		
	TIME (Hrs)	Ø STRAIN (Micro)		TIME (Hrs)	Ø STRAIN (Micro)
1	0.0002	10554.	16	0.0076	11364.
2	0.0005	10618.	17	0.0169	11354.
3	0.0008	10672.	18	0.0640	11293.
4	0.0010	10726.	19	0.1576	11354.
5	0.0013	10837.	20	0.3457	11354.
6	0.0016	10880.	21	0.6393	11354.
7	0.0019	10933.	22	1.0532	11364.
8	0.0024	10961.	23	1.6554	11364.
9	0.0026	11073.	24	2.2130	11326.
10	0.0029	11127.	25	2.9830	11386.
11	0.0032	11133.	26	3.8534	11406.
12	0.0035	11176.	27	4.3458	11417.
13	0.0037	11229.	28	5.8765	11423.
14	0.0040	11283.	29	7.5224	11409.
15	0.0043	11326.	30	9.1896	11395.
			31	11.2139	11392.
			32	14.1317	11397.
			33	17.8829	11399.
			34	22.4689	11398.
			35	28.4840	11407.
			36	35.9879	11416.
			37	43.8624	11409.

Specimen No. 7 - Step No. 8 - Initial Time = 336.492 Hours

STEP RESPONSE			RELAXATION		
	TIME (Hrs)	STRESS (Ksi)		TIME (Hrs)	STRESS (Ksi)
1	0.0002	15.993	16	0.0076	18.022
2	0.0005	16.166	17	0.0169	17.988
3	0.0008	16.304	18	0.0640	17.923
4	0.0010	16.476	19	0.1576	17.880
5	0.0013	16.597	20	0.3457	17.794
6	0.0016	16.748	21	0.6393	17.750
7	0.0019	16.899	22	1.0532	17.686
8	0.0024	17.146	23	1.6554	17.621
9	0.0026	17.288	24	2.2130	17.543
10	0.0029	17.439	25	2.9830	17.461
11	0.0032	17.590	26	3.8534	17.407
12	0.0035	17.720	27	4.3458	17.374
13	0.0037	17.849	28	5.8765	17.262
14	0.0040	18.000	29	7.5224	17.168
15	0.0043	18.108	30	9.1896	17.079
			31	11.2139	16.986
			32	14.1317	16.868
			33	17.8829	16.755
			34	22.4689	16.647
			35	28.4840	16.519
			36	35.9879	16.372
			37	43.8624	16.231



Specimen No. 7 - Step No. 8 - Initial Time = 336.492 Hours

STEP RESPONSE			RELAXATION		
	TIME (Hrs)	90 STRAIN (Micro)		TIME (Hrs)	90 STRAIN (Micro)
1	0.0002	-8362.	16	0.0076	-8932.
2	0.0005	-8393.	17	0.0169	-8978.
3	0.0008	-8444.	18	0.0640	-8932.
4	0.0010	-8475.	19	0.1576	-8932.
5	0.0013	-8560.	20	0.3457	-8989.
6	0.0016	-8601.	21	0.6393	-8952.
7	0.0019	-8632.	22	1.0532	-8952.
8	0.0024	-8705.	23	1.6554	-8916.
9	0.0026	-8736.	24	2.2130	-8973.
10	0.0029	-8756.	25	2.9830	-8983.
11	0.0032	-8797.	26	3.8534	-9000.
12	0.0035	-8839.	27	4.3458	-9008.
13	0.0037	-8870.	28	5.8765	-9022.
14	0.0040	-8901.	29	7.5224	-9023.
15	0.0043	-8932.	30	9.1896	-9033.
			31	11.2139	-9034.
			32	14.1317	-9046.
			33	17.8829	-9055.
			34	22.4689	-9073.
			35	28.4840	-9082.
			36	35.9879	-9100.
			37	43.8624	-9122.

Specimen No. 7 - Step No. 8 - Initial Time = 336.492 Hours

STEP RESPONSE			RELAXATION		
	TIME (Hrs)	45 STRAIN (Micro)		TIME (Hrs)	45 STRAIN (Micro)
1	0.0002	631.	16	0.0076	707.
2	0.0005	639.	17	0.0169	711.
3	0.0008	642.	18	0.0640	704.
4	0.0010	650.	19	0.1576	696.
5	0.0013	653.	20	0.3457	696.
6	0.0016	664.	21	0.6393	696.
7	0.0019	664.	22	1.0532	686.
8	0.0024	664.	23	1.6554	696.
9	0.0026	675.	24	2.2130	686.
10	0.0029	675.	25	2.9830	686.
11	0.0032	693.	26	3.8534	685.
12	0.0035	696.	27	4.3458	686.
13	0.0037	707.	28	5.8765	681.
14	0.0040	707.	29	7.5224	681.
15	0.0043	714.	30	9.1896	676.
			31	11.2139	673.
			32	14.1317	665.
			33	17.8829	658.
			34	22.4689	652.
			35	28.4840	649.
			36	35.9879	645.
			37	43.8624	635.

Specimen No. 7 - Step No. 9 - Initial Time = 383.833 Hours

STEP RESPONSE			RELAXATION		
	TIME (Hrs)	Ø STRAIN (Micro)		TIME (Hrs)	Ø STRAIN (Micro)
1	0.0001	11504.	16	0.0061	12215.
2	0.0004	11497.	17	0.0100	12215.
3	0.0007	11612.	18	0.0422	12335.
4	0.0009	11655.	19	0.1411	12258.
5	0.0012	11720.	20	0.3044	12390.
6	0.0017	11880.	21	0.7016	12335.
7	0.0020	11819.	22	1.0358	12269.
8	0.0023	11935.	23	1.5594	12346.
9	0.0026	11989.	24	2.0741	12346.
10	0.0028	12043.	25	2.6849	12291.
11	0.0031	12108.	26	3.2511	12356.
12	0.0034	12086.	27	4.3866	12337.
13	0.0037	12151.	28	5.5097	12314.
14	0.0040	12194.	29	6.9876	12311.
15	0.0042	12226.	30	8.7979	12322.
			31	10.9326	12337.
			32	14.1480	12346.
			33	17.5524	12330.
			34	22.2945	12335.
			35	28.4755	12339.
			36	35.7323	12349.
			37	45.0674	12348.
			38	56.7383	12339.
			39	66.3250	12339.

Specimen No. 7 - Step No. 9 - Initial Time = 383.833 Hours

STEP RESPONSE			RELAXATION		
	TIME (Hrs)	STRESS (Ksi)		TIME (Hrs)	STRESS (Ksi)
1	0.0001	16.390	16	0.0061	18.475
2	0.0004	16.563	17	0.0100	18.441
3	0.0007	16.705	18	0.0422	18.355
4	0.0009	16.865	19	0.1411	18.312
5	0.0012	17.007	20	0.3044	18.247
6	0.0017	17.297	21	0.7016	18.182
7	0.0020	17.439	22	1.0358	18.117
8	0.0023	17.590	23	1.5594	18.053
9	0.0026	17.741	24	2.0741	17.979
10	0.0028	17.871	25	2.6849	17.923
11	0.0031	18.022	26	3.2511	17.868
12	0.0034	18.194	27	4.3866	17.788
13	0.0037	18.345	28	5.5097	17.723
14	0.0040	18.475	29	6.9876	17.647
15	0.0042	18.552	30	8.7979	17.542
			31	10.9326	17.430
			32	14.1480	17.293
			33	17.5524	17.181
			34	22.2945	17.068
			35	28.4755	16.965
			36	35.7323	16.848
			37	45.0674	16.719
			38	56.7383	16.603
			39	66.3250	16.458

Specimen No. 7 - Step No. 9 - Initial Time = 383.833 Hours

STEP RESPONSE			RELAXATION		
	TIME (Hrs)	90 STRAIN (Micro)		TIME (Hrs)	90 STRAIN (Micro)
1	0.0001	-9189.	16	0.0061	-9756.
2	0.0004	-9220.	17	0.0100	-9705.
3	0.0007	-9262.	18	0.0422	-9766.
4	0.0009	-9352.	19	0.1411	-9715.
5	0.0012	-9334.	20	0.3044	-9777.
6	0.0017	-9406.	21	0.7016	-9777.
7	0.0020	-9437.	22	1.0358	-9736.
8	0.0023	-9468.	23	1.5594	-9797.
9	0.0026	-9460.	24	2.0741	-9757.
10	0.0028	-9550.	25	2.6849	-9757.
11	0.0031	-9542.	26	3.2511	-9818.
12	0.0034	-9623.	27	4.3866	-9782.
13	0.0037	-9614.	28	5.5097	-9773.
14	0.0040	-9644.	29	6.9876	-9798.
15	0.0042	-9705.	30	8.7979	-9811.
			31	10.9326	-9829.
			32	14.1480	-9851.
			33	17.5524	-9870.
			34	22.2945	-9882.
			35	28.4755	-9897.
			36	35.7323	-9914.
			37	45.0674	-9926.
			38	56.7383	-9934.
			39	66.3250	-9947.

Specimen No. 7 - Step No. 9 - Initial Time = 383.833 Hours

STEP RESPONSE			RELAXATION		
	TIME (Hrs)	45 STRAIN (Micro)		TIME (Hrs)	45 STRAIN (Micro)
1	0.0001	642.	16	0.0061	718.
2	0.0004	639.	17	0.0100	725.
3	0.0007	642.	18	0.0422	718.
4	0.0009	653.	19	0.1411	718.
5	0.0012	664.	20	0.3044	711.
6	0.0017	675.	21	0.7016	707.
7	0.0020	682.	22	1.0358	707.
8	0.0023	693.	23	1.5594	707.
9	0.0026	693.	24	2.0741	696.
10	0.0028	704.	25	2.6849	707.
11	0.0031	704.	26	3.2511	696.
12	0.0034	704.	27	4.3866	700.
13	0.0037	714.	28	5.5097	702.
14	0.0040	725.	29	6.9876	699.
15	0.0042	725.	30	8.7979	693.
			31	10.9326	685.
			32	14.1480	674.
			33	17.5524	662.
			34	22.2945	656.
			35	28.4755	654.
			36	35.7323	655.
			37	45.0674	655.
			38	56.7383	653.
			39	66.3250	650.

Specimen No. 7 - Step No. 10 - Initial Time = 453.707 Hours

STEP RESPONSE			RELAXATION		
	TIME (Hrs)	Ø STRAIN (Micro)		TIME (Hrs)	Ø STRAIN (Micro)
1	0.0006	12476.	14	0.0225	13212.
2	0.0009	12495.	15	0.0786	13201.
3	0.0012	12549.	16	0.2878	13201.
4	0.0015	12536.	17	0.6992	13201.
5	0.0018	12657.	18	1.2945	13142.
6	0.0020	12700.	19	1.7628	13201.
7	0.0023	12765.	20	2.4159	13250.
8	0.0026	12887.	21	3.2495	13158.
9	0.0029	12872.	22	4.2451	13096.
10	0.0032	12926.	23	5.5319	13072.
11	0.0034	12991.	24	6.9313	13046.
12	0.0039	13158.	25	8.9733	12984.
13	0.0042	13142.	26	10.9455	12911.
			27	14.1922	12847.
			28	17.5204	12810.
			29	19.0039	12518.
			30	19.0320	11968.
			31	19.0521	11524.
			32	19.0672	10983.
			33	19.1285	10507.
			34	19.5104	10026.
			35	20.3004	9545.
			36	21.5380	9008.
			37	27.4857	8515.
			38	36.9183	8026.

Specimen No. 7 - Step No. 10 - Initial Time = 453.707 Hours

STEP RESPONSE			RELAXATION		
	TIME (Hrs)	STRESS (Ksi)		TIME (Hrs)	STRESS (Ksi)
1	0.0006	16.627	14	0.0225	18.614
2	0.0009	16.878	15	0.0786	18.549
3	0.0012	17.016	16	0.2878	18.485
4	0.0015	17.180	17	0.6992	18.420
5	0.0018	17.318	18	1.2945	18.367
6	0.0020	17.470	19	1.7628	18.333
7	0.0023	17.633	20	2.4159	18.247
8	0.0026	17.794	21	3.2495	18.225
9	0.0029	17.923	22	4.2451	18.150
10	0.0032	18.086	23	5.5319	18.064
11	0.0034	18.259	24	6.9313	17.987
12	0.0039	18.506	25	8.9733	17.882
13	0.0042	18.679	26	10.9455	17.805
			27	14.1922	17.689
			28	18.9345	17.539
			29	21.7248	17.484
			30	28.9721	17.389
			31	34.5649	17.321
			32	43.8061	17.187

## STEP RESPONSE

## RELAXATION

	TIME (Hrs)	90 STRAIN (Micro)		TIME (Hrs)	90 STRAIN (Micro)
1	0.0006	-9963.	14	0.0225	-10575.
2	0.0009	-10004.	15	0.0786	-10585.
3	0.0012	-10107.	16	0.2878	-10596.
4	0.0015	-10086.	17	0.6992	-10540.
5	0.0018	-10179.	18	1.2945	-10551.
6	0.0020	-10221.	19	1.7628	-10606.
7	0.0023	-10199.	20	2.4159	-10616.
8	0.0026	-10293.	21	3.2495	-10571.
9	0.0029	-10388.	22	4.2451	-10586.
10	0.0032	-10365.	23	5.5319	-10606.
11	0.0034	-10461.	24	6.9313	-10624.
12	0.0039	-10414.	25	8.9733	-10632.
13	0.0042	-10509.	26	10.9455	-10632.
			27	14.1922	-10630.
			28	17.5204	-10638.
			29	19.0193	-10640.
			30	19.0523	-10523.
			31	19.0587	-10374.
			32	19.0882	-10254.
			33	19.2525	-10148.
			34	19.5626	-9969.
			35	20.6655	-9855.
			36	25.4976	-9709.
			37	33.0425	-9567.
			38	39.1542	-9458.

Specimen No. 7 - Step No. 10 - Initial Time = 453.707 Hours

## STEP RESPONSE

## RELAXATION

	TIME (Hrs)	45 STRAIN (Micro)		TIME (Hrs)	45 STRAIN (Micro)
1	0.0006	650.	14	0.0225	729.
2	0.0009	660.	15	0.0786	729.
3	0.0012	664.	16	0.2878	718.
4	0.0015	682.	17	0.6992	718.
5	0.0018	671.	18	1.2945	714.
6	0.0020	686.	19	1.7628	718.
7	0.0023	696.	20	2.4159	711.
8	0.0026	693.	21	3.2495	718.
9	0.0029	707.	22	4.2451	715.
10	0.0032	714.	23	5.5319	709.
11	0.0034	714.	24	6.9313	703.
12	0.0039	729.	25	8.9733	697.
13	0.0042	736.	26	10.9455	692.
			27	14.1922	682.
			28	17.5204	667.
			29	18.9578	592.
			30	19.0070	516.
			31	19.0202	478.
			32	19.0292	401.
			33	19.0362	348.
			34	19.0559	288.
			35	19.0652	232.
			36	19.1722	167.
			37	19.5373	98.
			38	19.7937	51.

Specimen No. 7 - Step No. 11 - Initial Time = 501.828 Hours

STEP RESPONSE

RELAXATION

	TIME (Hrs)	Ø STRAIN (Micro)		TIME (Hrs)	Ø STRAIN (Micro)
1	0.0002	7747.	16	0.0118	8253.
2	0.0005	7862.	17	0.0212	8231.
3	0.0008	7853.	18	0.0795	8165.
4	0.0011	7916.	19	0.1453	8122.
5	0.0014	7981.	20	0.2245	8079.
6	0.0018	7939.	21	0.2933	7967.
7	0.0020	8014.	22	0.3602	7777.
8	0.0023	8035.	23	0.4327	7615.
9	0.0026	8111.	24	0.5698	7466.
10	0.0029	8100.	25	0.7119	7405.
11	0.0032	8079.	26	0.8764	7355.
12	0.0034	8155.	27	1.1736	7299.
13	0.0037	8176.	28	1.4578	7256.
14	0.0040	8165.	29	1.8466	7181.
15	0.0043	8230.	30	2.2757	7104.
			31	2.6836	7041.
			32	2.8205	6162.
			33	2.8214	4714.
			34	2.9004	4640.
			35	3.6099	4395.
			36	4.2497	4262.
			37	5.5017	4145.
			38	7.2333	4062.
			39	8.4923	4015.
			40	11.3373	3969.
			41	14.4719	3917.
			42	18.2178	3871.
			43	23.2889	3827.
			44	28.2475	3801.
			45	35.9111	3771.
			46	44.5717	3733.

Specimen No. 7 - Step No. 11 - Initial Time = 501.828 Hours

STEP RESPONSE			RELAXATION		
	TIME (Hrs)	STRESS (Ksi)		TIME (Hrs)	STRESS (Ksi)
1	0.0002	17.254	16	0.0118	19.338
2	0.0005	17.383	17	0.0212	19.305
3	0.0008	17.534	18	0.0795	19.240
4	0.0011	17.707	19	0.1453	19.219
5	0.0014	17.858	20	0.2245	19.176
6	0.0018	18.074	21	0.2933	19.161
7	0.0020	18.247	22	0.3602	19.147
8	0.0023	18.398	23	0.4327	19.132
9	0.0026	18.549	24	0.5698	19.115
10	0.0029	18.700	25	0.7119	19.095
11	0.0032	18.852	26	0.8764	19.082
12	0.0034	19.003	27	1.1736	19.050
13	0.0037	19.144	28	1.4578	19.024
14	0.0040	19.284	29	1.8466	18.983
15	0.0043	19.403	30	2.2757	18.943
			31	2.8525	18.889
			32	3.6099	18.826
			33	4.2497	18.778
			34	5.5017	18.707
			35	7.2333	18.631
			36	8.4923	18.582
			37	11.3373	18.460
			38	14.4719	18.327
			39	18.2178	18.190
			40	23.2889	18.053
			41	28.2475	17.974
			42	35.9111	17.861
			43	44.5717	17.726

Specimen No. 7 - Step No. 11 - Initial Time = 501.828 Hours

STEP RESPONSE			RELAXATION		
	TIME (Hrs)	90 STRAIN (Micro)		TIME (Hrs)	90 STRAIN (Micro)
1	0.0002	-9486.	16	0.0118	-9880.
2	0.0005	-9478.	17	0.0212	-9932.
3	0.0008	-9509.	18	0.0795	-9922.
4	0.0011	-9590.	19	0.1453	-9911.
5	0.0014	-9571.	20	0.2245	-9901.
6	0.0018	-9612.	21	0.2933	-9790.
7	0.0020	-9694.	22	0.3602	-9635.
8	0.0023	-9725.	23	0.4327	-9520.
9	0.0026	-9756.	24	0.5698	-9406.
10	0.0029	-9787.	25	0.7119	-9347.
11	0.0032	-9767.	26	0.8764	-9284.
12	0.0034	-9798.	27	1.1736	-9234.
13	0.0037	-9818.	28	1.4578	-9217.
14	0.0040	-9849.	29	1.8466	-9081.
15	0.0043	-9922.	30	2.2757	-7044.
			31	2.8525	-4386.
			32	3.6099	-3322.
			33	4.2497	-3003.
			34	5.5017	-2920.
			35	7.2333	-2793.
			36	8.4923	-2720.
			37	11.3373	-2638.
			38	14.4719	-2604.
			39	18.2178	-2594.
			40	23.2889	-2581.
			41	28.2475	-2559.
			42	35.9111	-2534.
			43	44.5717	-2516.

Specimen No. 7 - Step No. 11 - Initial Time = 501.828 Hours

STEP RESPONSE			RELAXATION		
	TIME (Hrs)	45 STRAIN (Micro)		TIME (Hrs)	45 STRAIN (Micro)
1	0.0002	-449.	16	2.8205	6162.
2	0.0005	-449.	17	2.8214	4714.
3	0.0008	-449.	18	2.9004	4628.
4	0.0011	-449.			
5	0.0014	-451.			
6	0.0018	-438.			
7	0.0020	-438.			
8	0.0023	-438.			
9	0.0026	-438.			
10	0.0029	-440.			
11	0.0032	-438.			
12	0.0034	-438.			
13	0.0037	-438.			
14	0.0040	-438.			
15	0.0043	8230.			



Specimen No. 7 - Step No. 12 - Initial Time = 550.008 Hours

STEP RESPONSE			RELAXATION			
	TIME (Hrs)	Ø STRAIN (Micro)		TIME (Hrs)	Ø STRAIN (Micro)	
	1	0.0005	3725.	15	0.0087	3843.
	2	0.0008	3736.	16	0.0262	3842.
	3	0.0010	3767.	17	0.0732	3842.
	4	0.0013	3788.	18	0.1598	3812.
	5	0.0016	3778.	19	0.2504	3842.
	6	0.0019	3789.	20	0.4344	3831.
	7	0.0022	3769.	21	0.5603	3822.
	8	0.0024	3800.	22	0.7094	3817.
	9	0.0027	3831.	23	0.8837	3811.
	10	0.0032	3811.	24	1.0469	3812.
	11	0.0034	3801.	25	1.3426	3821.
	12	0.0037	3832.	26	1.7193	3831.
	13	0.0040	3832.	27	2.2783	3808.
	14	0.0043	3843.	28	2.7441	3796.
				29	3.5162	3768.
				30	4.2259	3736.
				31	4.3512	3725.
				32	4.3519	3487.
				33	4.3528	2809.
				34	4.5619	2756.
				35	5.8609	2668.
				36	6.8563	2635.
				37	8.8534	2644.
				38	11.8692	2651.
				39	14.3936	2640.
				40	17.3356	2609.
				41	22.4258	2573.
				42	27.0310	2561.
				43	35.6131	2574.
				44	45.0346	2576.

Specimen No. 7 - Step No. 12 - Initial Time = 550.008 Hours

STEP RESPONSE

RELAXATION

STEP RESPONSE			RELAXATION		
	TIME (Hrs)	STRESS (Ksi)		TIME (Hrs)	STRESS (Ksi)
1	0.0005	17.806	15	0.0087	19.845
2	0.0008	17.979	16	0.0262	19.802
3	0.0010	18.108	17	0.0732	19.715
4	0.0013	18.259	18	0.1598	19.705
5	0.0016	18.422	19	0.2504	19.629
6	0.0019	18.583	20	0.4344	19.543
7	0.0022	18.734	21	0.5603	19.515
8	0.0024	18.885	22	0.7094	19.479
9	0.0027	19.058	23	0.8837	19.441
10	0.0032	19.327	24	1.0469	19.405
11	0.0034	19.446	25	1.3426	19.358
12	0.0037	19.607	26	1.7193	19.305
13	0.0040	19.759	27	2.2783	19.237
14	0.0043	19.878	28	2.7441	19.157
			29	3.5162	18.820
			30	4.2259	18.350
			31	4.3512	18.129
			32	4.3519	13.288
			33	4.3528	2.320
			34	4.5619	2.245
			35	5.8609	2.089
			36	6.8563	2.017
			37	8.8534	1.968
			38	11.8692	1.911
			39	14.3936	1.884
			40	17.3356	1.866
			41	22.4258	1.851
			42	27.0310	1.850
			43	35.6131	1.841
			44	45.0346	1.827

Specimen No. 7 - Step No. 12 - Initial Time = 550.000 Hours

STEP RESPONSE			RELAXATION		
	TIME (Hrs)	90 STRAIN (Micro)		TIME (Hrs)	90 STRAIN (Micro)
1	0.0005	-2478.	15	0.0087	-2416.
2	0.0008	-2467.	16	0.0262	-2439.
3	0.0010	-2455.	17	0.0732	-2439.
4	0.0013	-2480.	18	0.1598	-2416.
5	0.0016	-2457.	19	0.2504	-2428.
6	0.0019	-2457.	20	0.4344	-2439.
7	0.0022	-2447.	21	0.5603	-2419.
8	0.0024	-2424.	22	0.7094	-2403.
9	0.0027	-2424.	23	0.8837	-2377.
10	0.0032	-2436.	24	1.0469	-2362.
11	0.0034	-2439.	25	1.3426	-2349.
12	0.0037	-2426.	26	1.7193	-2366.
13	0.0040	-2428.	27	2.2783	-2354.
14	0.0043	-2416.	28	2.7441	-2349.
			29	3.5162	-2468.
			30	4.3679	-2668.
			31	5.8609	-2959.
			32	6.8563	-3133.
			33	8.8534	-3102.
			34	11.8692	-3068.
			35	14.3936	-3060.
			36	17.3356	-3072.
			37	22.4258	-3084.
			38	27.0310	-3075.
			39	35.6131	-3022.
			40	45.0346	-2977.

Specimen No. 7 - Step No. 12 - Initial Time = 550.000 Hours

STEP RESPONSE			RELAXATION		
	TIME (Hrs)	45 STRAIN (Micro)		TIME (Hrs)	45 STRAIN (Micro)
1	0.0005	-1570.	15	4.3512	3730.
2	0.0008	-1570.	16	4.3519	3487.
3	0.0010	-1570.	17	4.3528	2867.
4	0.0013	-1592.	18	4.3574	2809.
5	0.0016	-1592.			
6	0.0019	-1592.			
7	0.0022	-1603.			
8	0.0024	-1603.			
9	0.0027	-1603.			
10	0.0032	-1634.			
11	0.0034	-1626.			
12	0.0037	-1637.			
13	0.0040	-1648.			
14	0.0043	3843.			

Specimen No. 8 - Step No. 1 - Initial Time = 0 Hours

STEP RESPONSE			RELAXATION		
	TIME (Hrs)	Ø STRAIN (Micro)		TIME (Hrs)	Ø STRAIN (Micro)
1	0.0007	74.	67	0.0458	2331.
2	0.0013	68.	68	0.0560	2324.
3	0.0018	68.	69	0.0658	2325.
4	0.0024	68.	70	0.0821	2301.
5	0.0032	62.	71	0.1013	2302.
6	0.0040	57.	72	0.1267	2313.
7	0.0045	57.	73	0.1800	2302.
8	0.0051	45.	74	0.2473	2302.
9	0.0056	40.	75	0.3684	2303.
10	0.0063	34.	76	0.4911	2311.
11	0.0071	17.	77	0.5428	2302.
12	0.0081	0.	78	0.7867	2302.
13	0.0090	-17.	79	1.0648	2301.
14	0.0097	-23.	80	1.3428	2313.
15	0.0104	-28.	81	1.7620	2315.
16	0.0111	-11.	82	2.3163	2317.
17	0.0117	45.	83	2.8739	2321.
18	0.0122	62.	84	3.5691	2325.
19	0.0131	68.	85	4.5427	2328.
20	0.0137	74.	86	5.5170	2330.
21	0.0143	74.	87	6.6467	2325.
22	0.0149	74.	88	8.8719	2320.
23	0.0157	80.	89	11.3728	2316.
24	0.0167	68.	90	14.1228	2314.
25	0.0177	91.	91	17.8182	2313.
26	0.0184	125.	92	22.4041	2316.
27	0.0189	182.	93	28.2419	2322.
28	0.0195	244.	94	35.7480	2327.
29	0.0201	302.	95	46.0810	2323.
30	0.0210	369.	96	50.9354	2315.
31	0.0217	422.			
32	0.0222	455.			
33	0.0228	484.			
34	0.0233	517.			
35	0.0240	553.			
36	0.0246	581.			
37	0.0252	627.			
38	0.0257	659.			
39	0.0263	705.			
40	0.0269	742.			
41	0.0276	793.			
42	0.0281	830.			
43	0.0287	875.			
44	0.0292	929.			
45	0.0299	989.			

Specimen No. 8 - Step No. 1 - Initial Time = 0 Hours

STEP RESPONSE			RELAXATION		
	TIME (Hrs)	STRESS (Ksi)		TIME (Hrs)	STRESS (Ksi)
1	0.0007	-0.248	67	0.0458	6.432
2	0.0013	-0.259	68	0.0560	6.354
3	0.0018	-0.248	69	0.0658	6.291
4	0.0024	-0.237	70	0.0821	6.291
5	0.0032	-0.237	71	0.1013	6.248
6	0.0040	-0.237	72	0.1267	6.226
7	0.0045	-0.226	73	0.1800	6.186
8	0.0051	-0.226	74	0.2473	6.186
9	0.0056	-0.226	75	0.3684	6.143
10	0.0063	-0.237	76	0.4911	6.201
11	0.0071	-0.237	77	0.5428	6.121
12	0.0081	-0.237	78	0.7867	6.100
13	0.0090	-0.226	79	1.0648	6.118
14	0.0097	-0.216	80	1.3428	6.097
15	0.0104	-0.194	81	1.7600	6.078
16	0.0111	-0.108	82	2.3163	6.064
17	0.0117	0.011	83	2.8739	6.054
18	0.0122	0.086	84	3.5691	6.039
19	0.0131	0.097	85	4.5427	6.022
20	0.0137	0.097	86	5.5170	6.007
21	0.0143	0.129	87	6.6467	5.991
22	0.0149	0.119	88	8.8719	5.966
23	0.0157	0.119	89	11.3728	5.946
24	0.0167	0.108	90	14.1228	5.928
25	0.0177	0.129	91	17.8182	5.905
26	0.0184	0.259	92	22.4041	5.890
27	0.0189	0.431	93	28.2419	5.885
28	0.0195	0.604	94	35.7480	5.874
29	0.0201	0.776	95	46.0810	5.841
30	0.0210	0.992	96	50.9354	5.798
31	0.0217	1.132			
32	0.0222	1.261			
33	0.0228	1.337			
34	0.0233	1.455			
35	0.0240	1.541			
36	0.0246	1.660			
37	0.0252	1.778			
38	0.0257	1.896			
39	0.0263	1.994			
40	0.0269	2.123			
41	0.0276	2.263			
42	0.0281	2.392			
43	0.0287	2.522			
44	0.0292	2.661			
45	0.0299	2.823			

Specimen No. 8 - Step No. 1 - Initial Time = 0 Hours

STEP RESPONSE			RELAXATION		
	TIME (Hrs)	90 STRAIN (Micro)		TIME (Hrs)	90 STRAIN (Micro)
1	0.0007	95.	67	0.0458	-1705.
2	0.0013	101.	68	0.0560	-1706.
3	0.0018	112.	69	0.0658	-1716.
4	0.0024	112.	70	0.0821	-1684.
5	0.0032	122.	71	0.1013	-1705.
6	0.0040	129.	72	0.1267	-1705.
7	0.0045	123.	73	0.1800	-1716.
8	0.0051	134.	74	0.2473	-1716.
9	0.0056	134.	75	0.3684	-1750.
10	0.0063	139.	76	0.4911	-1698.
11	0.0071	145.	77	0.5428	-1738.
12	0.0081	156.	78	0.7867	-1761.
13	0.0090	167.	79	1.0648	-1729.
14	0.0097	173.	80	1.3428	-1738.
15	0.0104	185.	81	1.7600	-1736.
16	0.0111	157.	82	2.3163	-1727.
17	0.0117	112.	83	2.8739	-1723.
18	0.0122	89.	84	3.5691	-1724.
19	0.0131	84.	85	4.5427	-1727.
20	0.0137	78.	86	5.5170	-1728.
21	0.0143	67.	87	6.6467	-1727.
22	0.0149	67.	88	8.8719	-1729.
23	0.0157	62.	89	11.3728	-1723.
24	0.0167	56.	90	14.1228	-1715.
25	0.0177	45.	91	17.8182	-1717.
26	0.0184	22.	92	22.4041	-1729.
27	0.0189	-34.	93	28.2419	-1747.
28	0.0195	-67.	94	35.7480	-1773.
29	0.0201	-112.	95	46.0810	-1815.
30	0.0210	-162.	96	50.9354	-1861.
31	0.0217	-201.			
32	0.0222	-241.			
33	0.0228	-269.			
34	0.0233	-296.			
35	0.0240	-331.			
36	0.0246	-353.			
37	0.0252	-385.			
38	0.0257	-407.			
39	0.0263	-435.			
40	0.0269	-487.			
41	0.0276	-508.			
42	0.0281	-548.			
43	0.0287	-580.			
44	0.0292	-621.			
45	0.0299	-658.			

Specimen No. 8 - Step No. 1 - Initial Time = 0 Hours

STEP RESPONSE			RELAXATION		
	TIME (Hrs)	45 STRAIN (Micro)		TIME (Hrs)	45 STRAIN (Micro)
1	0.0007	210.	67	0.0458	396.
2	0.0013	210.	68	0.0560	396.
3	0.0018	210.	69	0.0658	396.
4	0.0024	205.	70	0.0821	396.
5	0.0032	215.	71	0.1013	396.
6	0.0040	205.	72	0.1267	396.
7	0.0045	198.	73	0.1800	385.
8	0.0051	198.	74	0.2473	385.
9	0.0056	198.	75	0.3684	373.
10	0.0063	198.	76	0.4911	406.
11	0.0071	187.	77	0.5428	385.
12	0.0081	176.	78	0.7867	385.
13	0.0090	170.	79	1.0648	394.
14	0.0097	163.	80	1.3428	385.
15	0.0104	152.	81	1.7600	382.
16	0.0111	152.	82	2.3163	382.
17	0.0117	152.	83	2.8739	384.
18	0.0122	152.	84	3.5691	383.
19	0.0131	152.	85	4.5427	383.
20	0.0137	152.	86	5.5170	382.
21	0.0143	140.	87	6.6467	381.
22	0.0149	140.	88	8.8719	376.
23	0.0157	135.	89	11.3728	373.
24	0.0167	123.	90	14.1228	369.
25	0.0177	123.	91	17.8182	364.
26	0.0184	129.	92	22.4041	361.
27	0.0189	129.	93	28.2419	363.
28	0.0195	141.	94	35.7480	363.
29	0.0201	152.	95	46.0810	353.
30	0.0210	164.	96	58.9354	340.
31	0.0217	163.			
32	0.0222	170.			
33	0.0228	175.			
34	0.0233	175.			
35	0.0240	181.			
36	0.0246	188.			
37	0.0252	192.			
38	0.0257	198.			
39	0.0263	210.			
40	0.0269	210.			
41	0.0276	221.			
42	0.0281	221.			
43	0.0287	233.			
44	0.0292	238.			
45	0.0299	250.			

Specimen No. 8 - Step No. 2 - Initial Time = 51.449 Hours

STEP RESPONSE

RELAXATION

STEP RESPONSE			RELAXATION		
	TIME (Hrs)	Ø STRAIN (Micro)		TIME (Hrs)	Ø STRAIN (Micro)
1	0.0004	2370.	29	0.0107	3598.
2	0.0007	2427.	30	0.0154	3598.
3	0.0010	2484.	31	0.0243	3578.
4	0.0014	2530.	32	0.0352	3586.
5	0.0017	2564.	33	0.0604	3586.
6	0.0019	2610.	34	0.1009	3586.
7	0.0022	2655.	35	0.1814	3575.
8	0.0025	2689.	36	0.2695	3567.
9	0.0028	2735.	37	0.3862	3595.
10	0.0030	2777.	38	0.6170	3575.
11	0.0033	2822.	39	0.9448	3595.
12	0.0036	2856.	40	1.3564	3575.
13	0.0039	2902.	41	1.9314	3586.
14	0.0044	2966.	42	2.9086	3580.
15	0.0047	3031.	43	3.4212	3592.
16	0.0050	3077.	44	4.3161	3604.
17	0.0053	3111.	45	5.6473	3612.
18	0.0055	3157.	46	6.9666	3611.
19	0.0058	3191.	47	8.4899	3606.
20	0.0061	3254.	48	11.2977	3605.
21	0.0064	3282.	49	14.2155	3598.
22	0.0066	3316.	50	18.0400	3591.
23	0.0069	3362.	51	22.6471	3598.
24	0.0074	3438.	52	28.4825	3609.
25	0.0077	3476.	53	35.9852	3615.
26	0.0079	3510.	54	44.7383	3608.
27	0.0082	3536.			
28	0.0085	3590.			



Specimen No. 8 - Step No. 2 - Initial Time = 51.449 Hours

STEP RESPONSE			RELAXATION		
	TIME (Hrs)	STRESS (Ksi)		TIME (Hrs)	STRESS (Ksi)
1	0.0004	5.992	29	0.0107	9.199
2	0.0007	6.140	30	0.0154	9.130
3	0.0010	6.266	31	0.0243	9.096
4	0.0014	6.398	32	0.0352	9.048
5	0.0017	6.506	33	0.0604	9.010
6	0.0019	6.639	34	0.1009	8.967
7	0.0022	6.765	35	0.1814	8.919
8	0.0025	6.851	36	0.2695	8.897
9	0.0028	6.977	37	0.3862	8.859
10	0.0030	7.127	38	0.6170	8.794
11	0.0033	7.235	39	0.9448	8.773
12	0.0036	7.346	40	1.3564	8.747
13	0.0039	7.476	41	1.9314	8.730
14	0.0044	7.669	42	2.9086	8.721
15	0.0047	7.777	43	3.4212	8.708
16	0.0050	7.885	44	4.3161	8.695
17	0.0053	7.993	45	5.6473	8.673
18	0.0055	8.100	46	6.9666	8.648
19	0.0058	8.208	47	8.4899	8.620
20	0.0061	8.333	48	11.2977	8.582
21	0.0064	8.424	49	14.2155	8.554
22	0.0066	8.553	50	18.0400	8.517
23	0.0069	8.656	51	22.6471	8.501
24	0.0074	8.833	52	28.4825	8.478
25	0.0077	8.941	53	35.9852	8.455
26	0.0079	9.048	54	44.7383	8.414
27	0.0082	9.156			
28	0.0085	9.259			

Specimen No. 8 - Step No. 2 - Initial Time = 51.449 Hours

STEP RESPONSE			RELAXATION			
	TIME (Hrs)	90 STRAIN (Micro)		TIME (Hrs)	90 STRAIN (Micro)	
	1	0.0004	-1884.	29	0.0107	-2831.
	2	0.0007	-1908.	30	0.0154	-2804.
	3	0.0010	-1952.	31	0.0243	-2815.
	4	0.0014	-1974.	32	0.0352	-2815.
	5	0.0017	-2030.	33	0.0604	-2826.
	6	0.0019	-2064.	34	0.1009	-2842.
	7	0.0022	-2097.	35	0.1814	-2853.
	8	0.0025	-2120.	36	0.2695	-2826.
	9	0.0028	-2153.	37	0.3862	-2865.
	10	0.0030	-2187.	38	0.6170	-2853.
	11	0.0033	-2198.	39	0.9448	-2865.
	12	0.0036	-2242.	40	1.3564	-2849.
	13	0.0039	-2264.	41	1.9314	-2876.
	14	0.0044	-2344.	42	2.9086	-2856.
	15	0.0047	-2354.	43	3.4212	-2869.
	16	0.0050	-2387.	44	4.3161	-2876.
	17	0.0053	-2434.	45	5.6473	-2878.
	18	0.0055	-2468.	46	6.9666	-2879.
	19	0.0058	-2476.	47	8.4899	-2880.
	20	0.0061	-2524.	48	11.2977	-2883.
	21	0.0064	-2557.	49	14.2155	-2885.
	22	0.0066	-2591.	50	18.0400	-2888.
	23	0.0069	-2625.	51	22.6471	-2881.
	24	0.0074	-2681.	52	28.4825	-2873.
	25	0.0077	-2714.	53	35.9852	-2870.
	26	0.0079	-2763.	54	44.7383	-2881.
	27	0.0082	-2770.			
	28	0.0085	-2804.			

Specimen No. 8 - Step No. 2 - Initial Time = 51.449 Hours

STEP RESPONSE			RELAXATION		
	TIME (Hrs)	45 STRAIN (Micro)		TIME (Hrs)	45 STRAIN (Micro)
1	0.0004	362.	29	0.0107	478.
2	0.0007	348.	30	0.0154	490.
3	0.0010	371.	31	0.0243	487.
4	0.0014	373.	32	0.0352	478.
5	0.0017	373.	33	0.0604	478.
6	0.0019	373.	34	0.1009	478.
7	0.0022	385.	35	0.1814	478.
8	0.0025	385.	36	0.2695	478.
9	0.0028	394.	37	0.3862	457.
10	0.0030	406.	38	0.6170	466.
11	0.0033	418.	39	0.9448	469.
12	0.0036	418.	40	1.3564	466.
13	0.0039	418.	41	1.9314	466.
14	0.0044	431.	42	2.9086	481.
15	0.0047	429.	43	3.4212	478.
16	0.0050	429.	44	4.3161	478.
17	0.0053	443.	45	5.6473	478.
18	0.0055	441.	46	6.9666	477.
19	0.0058	452.	47	8.4899	474.
20	0.0061	464.	48	11.2977	470.
21	0.0064	455.	49	14.2155	464.
22	0.0066	466.	50	18.0400	459.
23	0.0069	476.	51	22.6471	460.
24	0.0074	478.	52	28.4825	458.
25	0.0077	478.	53	35.9852	452.
26	0.0079	478.	54	44.7383	436.
27	0.0082	487.			
28	0.0085	499.			

AD-A141 637

MATRIX-DOMINATED TIME-DEPENDENT DEFORMATION AND DAMAGE  
OF GRAPHITE EPOXY. (U) LAWRENCE LIVERMORE NATIONAL LAB  
CA E M WU ET AL. MAY 83 UCID-19765 AFML-TR-83-3056  
W-7405-ENG-48

6/6

UNCLASSIFIED

F/G 11/9

NL



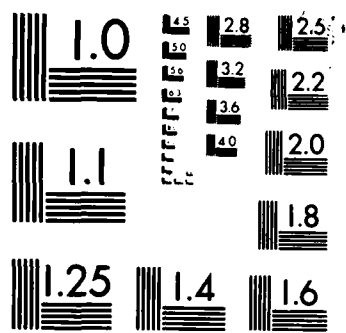

MICROCOPY RESOLUTION TEST CHART  
NATIONAL BUREAU OF STANDARDS 1963-A

Specimen No. 8 - Step No. 3 - Initial Time = 100.588 Hours

STEP RESPONSE

RELAXATION

STEP RESPONSE			RELAXATION		
	TIME (Hrs)	Ø STRAIN (Micro)		TIME (Hrs)	Ø STRAIN (Micro)
1	0.0000	3635.	30	0.0114	4984.
2	0.0003	3704.	31	0.0156	4984.
3	0.0007	3761.	32	0.0238	4984.
4	0.0010	3839.	33	0.0377	4973.
5	0.0013	3884.	34	0.0563	4984.
6	0.0015	3919.	35	0.0811	4984.
7	0.0018	3953.	36	0.1250	4984.
8	0.0021	3999.	37	0.1680	4984.
9	0.0024	4035.	38	0.2422	5000.
10	0.0026	4113.	39	0.3625	4984.
11	0.0029	4136.	40	0.4463	4983.
12	0.0032	4160.	41	0.5613	4984.
13	0.0038	4285.	42	0.8396	4996.
14	0.0041	4331.	43	1.0810	4996.
15	0.0043	4366.	44	1.5305	5019.
16	0.0046	4424.	45	1.8319	5035.
17	0.0049	4457.	46	2.5013	5046.
18	0.0052	4503.	47	3.1174	5046.
19	0.0055	4538.	48	3.5701	5041.
20	0.0057	4595.	49	4.6072	5032.
21	0.0060	4629.	50	5.5004	5030.
22	0.0063	4661.	51	6.8424	5028.
23	0.0067	4744.	52	9.1019	5028.
24	0.0070	4764.	53	11.5635	5029.
25	0.0073	4835.	54	14.2626	5028.
26	0.0075	4870.	55	17.9423	5030.
27	0.0078	4916.	56	22.5277	5038.
28	0.0081	4961.	57	28.3685	5045.
29	0.0084	4996.	58	35.8711	5051.
			59	43.7947	5048.

Specimen No. 8 - Step No. 3 - Initial Time = 100.588 Hours

STEP RESPONSE			RELAXATION		
	TIME (Hrs)	STRESS (Ksi)		TIME (Hrs)	STRESS (Ksi)
1	0.0000	8.514	30	0.0114	11.917
2	0.0003	8.682	31	0.0156	11.849
3	0.0007	8.854	32	0.0238	11.806
4	0.0010	9.010	33	0.0377	11.726
5	0.0013	9.118	34	0.0563	11.698
6	0.0015	9.242	35	0.0811	11.649
7	0.0018	9.333	36	0.1250	11.606
8	0.0021	9.462	37	0.1680	11.569
9	0.0024	9.592	38	0.2422	11.510
10	0.0026	9.700	39	0.3625	11.483
11	0.0029	9.829	40	0.4463	11.458
12	0.0032	9.953	41	0.5613	11.424
13	0.0038	10.190	42	0.8396	11.375
14	0.0041	10.319	43	1.0810	11.359
15	0.0043	10.427	44	1.5305	11.310
16	0.0046	10.540	45	1.8319	11.267
17	0.0049	10.648	46	2.5013	11.230
18	0.0052	10.777	47	3.1174	11.230
19	0.0055	10.879	48	3.5701	11.209
20	0.0057	11.009	49	4.6072	11.164
21	0.0060	11.122	50	5.5004	11.116
22	0.0063	11.218	51	6.8424	11.072
23	0.0067	11.397	52	9.1019	11.016
24	0.0070	11.504	53	11.5635	10.967
25	0.0073	11.590	54	14.2626	10.921
26	0.0075	11.698	55	17.9423	10.876
27	0.0078	11.806	56	22.5277	10.842
28	0.0081	11.914	57	28.3685	10.804
29	0.0084	12.000	58	35.8711	10.747
			59	43.7947	10.687

Specimen No. 8 - Step No. 3 - Initial Time = 100.588 Hours

STEP RESPONSE			RELAXATION		
	TIME (Hrs)	90 STRAIN (Micro)		TIME (Hrs)	90 STRAIN (Micro)
1	0.0000	-2894.	30	0.0114	-3925.
2	0.0003	-2923.	31	0.0156	-3925.
3	0.0007	-2995.	32	0.0238	-3914.
4	0.0010	-3040.	33	0.0377	-3936.
5	0.0013	-3073.	34	0.0563	-3914.
6	0.0015	-3084.	35	0.0811	-3947.
7	0.0018	-3129.	36	0.1250	-3926.
8	0.0021	-3180.	37	0.1680	-3970.
9	0.0024	-3197.	38	0.2422	-3970.
10	0.0026	-3248.	39	0.3625	-3970.
11	0.0029	-3282.	40	0.4463	-3972.
12	0.0032	-3286.	41	0.5613	-3992.
13	0.0038	-3365.	42	0.8396	-3992.
14	0.0041	-3387.	43	1.0810	-4004.
15	0.0043	-3451.	44	1.5305	-3993.
16	0.0046	-3485.	45	1.8319	-4026.
17	0.0049	-3499.	46	2.5013	-4026.
18	0.0052	-3541.	47	3.1174	-4071.
19	0.0055	-3556.	48	3.5701	-4039.
20	0.0057	-3609.	49	4.6072	-4031.
21	0.0060	-3623.	50	5.5004	-4049.
22	0.0063	-3645.	51	6.8424	-4052.
23	0.0067	-3722.	52	9.1019	-4056.
24	0.0070	-3735.	53	11.5635	-4062.
25	0.0073	-3769.	54	14.2626	-4069.
26	0.0075	-3823.	55	17.9423	-4076.
27	0.0078	-3825.	56	22.5277	-4082.
28	0.0081	-3870.	57	28.3685	-4086.
29	0.0084	-3925.	58	35.8711	-4095.
			59	43.7947	-4102.



Specimen No. 8 - Step No. 3 - Initial Time = 100.588 Hours

STEP RESPONSE			RELAXATION		
	TIME (Hrs)	45 STRAIN (Micro)		TIME (Hrs)	45 STRAIN (Micro)
1	0.0000	443.	30	0.0114	582.
2	0.0003	455.	31	0.0156	571.
3	0.0007	452.	32	0.0238	575.
4	0.0010	466.	33	0.0377	560.
5	0.0013	466.	34	0.0563	568.
6	0.0015	478.	35	0.0811	568.
7	0.0018	466.	36	0.1250	568.
8	0.0021	478.	37	0.1680	560.
9	0.0024	481.	38	0.2422	563.
10	0.0026	492.	39	0.3625	560.
11	0.0029	490.	40	0.4463	556.
12	0.0032	501.	41	0.5613	548.
13	0.0038	513.	42	0.8396	548.
14	0.0041	513.	43	1.0810	548.
15	0.0043	513.	44	1.5305	560.
16	0.0046	525.	45	1.8319	536.
17	0.0049	525.	46	2.5013	548.
18	0.0052	536.	47	3.1174	536.
19	0.0055	536.	48	3.5781	545.
20	0.0057	539.	49	4.6072	550.
21	0.0060	548.	50	5.5004	548.
22	0.0063	557.	51	6.8424	546.
23	0.0067	560.	52	9.1019	544.
24	0.0070	571.	53	11.5635	537.
25	0.0073	571.	54	14.2626	530.
26	0.0075	571.	55	17.9423	525.
27	0.0078	571.	56	22.5277	528.
28	0.0081	583.	57	28.3685	531.
29	0.0084	583.	58	35.8711	528.
			59	43.7947	519.

Specimen No. 8 - Step No. 4 - Initial Time = 148.224 Hours

STEP RESPONSE			RELAXATION		
	TIME (Hrs)	Ø STRAIN (Micro)		TIME (Hrs)	Ø STRAIN (Micro)
1	0.0006	5099.	15	0.0089	5795.
2	0.0009	5168.	16	0.0330	5784.
3	0.0011	5214.	17	0.1590	5784.
4	0.0014	5242.	18	0.4031	5784.
5	0.0017	5328.	19	0.8401	5764.
6	0.0020	5374.	20	1.5712	5755.
7	0.0025	5454.	21	2.0468	5807.
8	0.0027	5500.	22	2.9007	5792.
9	0.0030	5546.	23	3.8793	5798.
10	0.0033	5592.	24	4.6960	5798.
11	0.0036	5638.	25	5.5296	5766.
12	0.0039	5683.	26	6.7509	5800.
13	0.0041	5741.	27	8.8055	5802.
14	0.0044	5786.	28	11.3063	5789.
			29	14.2241	5789.
			30	17.9769	5796.
			31	22.5635	5810.
			32	28.3996	5820.
			33	35.9023	5824.
			34	45.0075	5826.

Specimen No. 8 - Step No. 4 - Initial Time = 148.224 Hours

STEP RESPONSE			RELAXATION		
	TIME (Hrs)	STRESS (Ksi)		TIME (Hrs)	STRESS (Ksi)
1	0.0006	10.793	15	0.0089	12.517
2	0.0009	10.944	16	0.0330	12.480
3	0.0011	11.095	17	0.1590	12.409
4	0.0014	11.267	18	0.4031	12.372
5	0.0017	11.397	19	0.8401	12.323
6	0.0020	11.526	20	1.5712	12.317
7	0.0025	11.741	21	2.0468	12.258
8	0.0027	11.849	22	2.9007	12.240
9	0.0030	12.000	23	3.8793	12.187
10	0.0033	12.107	24	4.6960	12.172
11	0.0036	12.237	25	5.5296	12.172
12	0.0039	12.344	26	6.7509	12.118
13	0.0041	12.495	27	8.8055	12.064
14	0.0044	12.597	28	11.3063	12.019
			29	14.2241	11.973
			30	17.9769	11.916
			31	22.5635	11.862
			32	28.3996	11.798
			33	35.9023	11.724
			34	45.0075	11.639

Specimen No. 8 - Step No. 4 - Initial Time = 148.224 Hours

STEP RESPONSE			RELAXATION		
	TIME (Hrs)	90 STRAIN (Micro)		TIME (Hrs)	90 STRAIN (Micro)
1	0.0006	-4128.	15	0.0089	-4635.
2	0.0009	-4161.	16	0.0330	-4661.
3	0.0011	-4229.	17	0.1590	-4646.
4	0.0014	-4240.	18	0.4031	-4646.
5	0.0017	-4297.	19	0.8401	-4646.
6	0.0020	-4318.	20	1.5712	-4585.
7	0.0025	-4363.	21	2.0468	-4669.
8	0.0027	-4432.	22	2.9007	-4659.
9	0.0030	-4442.	23	3.8793	-4680.
10	0.0033	-4500.	24	4.6960	-4655.
11	0.0036	-4534.	25	5.5296	-4655.
12	0.0039	-4543.	26	6.7509	-4666.
13	0.0041	-4565.	27	8.8055	-4672.
14	0.0044	-4599.	28	11.3063	-4678.
			29	14.2241	-4686.
			30	17.9769	-4698.
			31	22.5635	-4700.
			32	28.3996	-4701.
			33	35.9023	-4707.
			34	45.0075	-4719.

Specimen No. 8 - Step No. 4 - Initial Time = 148.224 Hours

STEP RESPONSE			RELAXATION		
	TIME (Hrs)	45 STRAIN (Micro)		TIME (Hrs)	45 STRAIN (Micro)
1	0.0006	534.	15	0.0089	595.
2	0.0009	534.	16	0.0330	595.
3	0.0011	545.	17	0.1590	583.
4	0.0014	560.	18	0.4031	583.
5	0.0017	557.	19	0.8401	595.
6	0.0020	557.	20	1.5712	611.
7	0.0025	568.	21	2.0468	595.
8	0.0027	571.	22	2.9007	597.
9	0.0030	580.	23	3.8793	591.
10	0.0033	583.	24	4.6960	591.
11	0.0036	583.	25	5.5296	603.
12	0.0039	591.	26	6.7509	597.
13	0.0041	603.	27	8.8055	591.
14	0.0044	603.	28	11.3063	584.
			29	14.2241	577.
			30	17.9769	573.
			31	22.5635	579.
			32	28.3996	586.
			33	35.9023	588.
			34	45.0075	581.

Specimen No. 8 - Step No. 5 - Initial Time = 197.091 Hours

STEP RESPONSE			RELAXATION		
	TIME (Hrs)	Ø STRAIN (Micro)		TIME (Hrs)	Ø STRAIN (Micro)
1	0.0003	5913.	15	0.0101	6589.
2	0.0006	5970.	16	0.0328	6613.
3	0.0009	6039.	17	0.1126	6613.
4	0.0012	6096.	18	0.2543	6613.
5	0.0015	6142.	19	0.5465	6613.
6	0.0017	6199.	20	0.9706	6577.
7	0.0020	6233.	21	1.4755	6577.
8	0.0026	6325.	22	2.1903	6601.
9	0.0028	6371.	23	2.7197	6589.
10	0.0031	6405.	24	3.4966	6636.
11	0.0034	6463.	25	4.4849	6609.
12	0.0037	6544.	26	5.9308	6598.
13	0.0039	6554.	27	6.7129	6598.
14	0.0042	6625.	28	8.9434	6604.
			29	11.1807	6610.
			30	13.9666	6610.
			31	17.2841	6610.
			32	22.5394	6615.
			33	28.3758	6620.
			34	35.8785	6617.

Specimen No. 8 - Step No. 5 - Initial Time = 197.091 Hours

STEP RESPONSE			RELAXATION		
	TIME (Hrs)	STRESS (Ksi)		TIME (Hrs)	STRESS (Ksi)
1	0.0003	11.843	15	0.0101	13.551
2	0.0006	11.994	16	0.0328	13.486
3	0.0009	12.144	17	0.1126	13.465
4	0.0012	12.295	18	0.2543	13.379
5	0.0015	12.452	19	0.5465	13.335
6	0.0017	12.553	20	0.9706	13.314
7	0.0020	12.683	21	1.4755	13.228
8	0.0026	12.926	22	2.1903	13.216
9	0.0028	13.027	23	2.7197	13.185
10	0.0031	13.163	24	3.4966	13.142
11	0.0034	13.271	25	4.4849	13.081
12	0.0037	13.400	26	5.9308	13.041
13	0.0039	13.508	27	6.7129	13.020
14	0.0042	13.615	28	8.9434	12.956
			29	11.1807	12.898
			30	13.9666	12.846
			31	17.2841	12.802
			32	22.5394	12.755
			33	28.3758	12.699
			34	35.8785	12.622

Specimen No. 8 - Step No. 5 - Initial Time = 197.091 Hours

STEP RESPONSE			RELAXATION		
	TIME (Hrs)	90 STRAIN (Micro)		TIME (Hrs)	90 STRAIN (Micro)
1	0.0003	-4744.	15	0.0101	-5238.
2	0.0006	-4800.	16	0.0328	-5278.
3	0.0009	-4834.	17	0.1126	-5278.
4	0.0012	-4868.	18	0.2543	-5318.
5	0.0015	-4913.	19	0.5465	-5278.
6	0.0017	-4946.	20	0.9706	-5260.
7	0.0020	-5019.	21	1.4755	-5330.
8	0.0026	-5020.	22	2.1903	-5279.
9	0.0028	-5081.	23	2.7197	-5312.
10	0.0031	-5103.	24	3.4966	-5312.
11	0.0034	-5148.	25	4.4849	-5288.
12	0.0037	-5210.	26	5.9308	-5277.
13	0.0039	-5204.	27	6.7129	-5277.
14	0.0042	-5278.	28	8.9434	-5292.
			29	11.1807	-5310.
			30	13.9666	-5325.
			31	17.2841	-5330.
			32	22.5394	-5336.
			33	28.3758	-5355.
			34	35.8785	-5382.

Specimen No. 8 - Step No. 5 - Initial Time = 197.091 Hours

STEP RESPONSE			RELAXATION		
	TIME (Hrs)	45 STRAIN (Micro)		TIME (Hrs)	45 STRAIN (Micro)
1	0.0003	603.	15	0.0101	661.
2	0.0006	603.	16	0.0328	649.
3	0.0009	603.	17	0.1126	661.
4	0.0012	626.	18	0.2543	653.
5	0.0015	615.	19	0.5465	649.
6	0.0017	626.	20	0.9706	653.
7	0.0020	638.	21	1.4755	638.
8	0.0026	634.	22	2.1903	653.
9	0.0028	649.	23	2.7197	649.
10	0.0031	649.	24	3.4966	638.
11	0.0034	649.	25	4.4849	643.
12	0.0037	661.	26	5.9308	642.
13	0.0039	673.	27	6.7129	640.
14	0.0042	665.	28	8.9434	632.
			29	11.1807	628.
			30	13.9666	624.
			31	17.2841	620.
			32	22.5394	617.
			33	28.3758	611.
			34	35.8785	602.

Specimen No. 8 - Step No. 6 - Initial Time = 237.231 Hours

STEP RESPONSE			RELAXATION			
	TIME (Hrs)	Ø STRAIN (Micro)		TIME (Hrs)	Ø STRAIN (Micro)	
	1	0.0001	6669.	16	0.0064	7397.
	2	0.0004	6763.	17	0.0167	7385.
	3	0.0007	6795.	18	0.0639	7385.
	4	0.0010	6852.	19	0.1589	7414.
	5	0.0014	6895.	20	0.3812	7385.
	6	0.0016	7016.	21	0.8198	7385.
	7	0.0019	7063.	22	1.2451	7385.
	8	0.0022	7070.	23	1.9669	7364.
	9	0.0025	7116.	24	1.9957	7356.
	10	0.0028	7189.	25	2.7204	7397.
	11	0.0030	7235.	26	3.3504	7345.
	12	0.0033	7281.	27	4.4870	7376.
	13	0.0036	7299.	28	5.7065	7368.
	14	0.0039	7345.	29	6.9570	7381.
	15	0.0042	7379.	30	9.0410	7400.
				31	11.5230	7413.
				32	14.4406	7420.
				33	18.1919	7422.
				34	22.2552	7420.
				35	28.0868	7426.
				36	35.8780	7427.
				37	45.0878	7430.
				38	50.4193	7428.

Specimen No. 8 - Step No. 6 - Initial Time = 237.231 Hours

STEP RESPONSE			RELAXATION			
	TIME (Hrs)	STRESS (Ksi)		TIME (Hrs)	STRESS (Ksi)	
	1	0.0001	12.775	16	0.0064	14.520
	2	0.0004	12.926	17	0.0167	14.477
	3	0.0007	13.077	18	0.0639	14.413
	4	0.0010	13.228	19	0.1589	14.398
	5	0.0014	13.443	20	0.3812	14.305
	6	0.0016	13.572	21	0.8198	14.283
	7	0.0019	13.680	22	1.2451	14.226
	8	0.0022	13.831	23	1.9669	14.150
	9	0.0025	13.939	24	1.9957	14.154
	10	0.0028	14.046	25	2.7204	14.118
	11	0.0030	14.154	26	3.3504	14.068
	12	0.0033	14.262	27	4.4870	14.022
	13	0.0036	14.405	28	5.7065	13.982
	14	0.0039	14.520	29	6.9570	13.945
	15	0.0042	14.599	30	9.0410	13.904
				31	11.5230	13.851
				32	14.4406	13.783
				33	18.1919	13.691
				34	22.2552	13.616
				35	28.0868	13.548
				36	35.8780	13.474
				37	45.0878	13.396
				38	50.4193	13.360

Specimen No. 8 - Step No. 6 - Initial Time = 237.231 Hours

STEP RESPONSE			RELAXATION		
	TIME (Hrs)	90 STRAIN (Micro)		TIME (Hrs)	90 STRAIN (Micro)
1	0.0001	-5458.	16	0.0064	-5943.
2	0.0004	-5492.	17	0.0167	-5943.
3	0.0007	-5526.	18	0.0639	-5943.
4	0.0010	-5541.	19	0.1589	-5943.
5	0.0014	-5597.	20	0.3812	-5955.
6	0.0016	-5673.	21	0.8198	-5966.
7	0.0019	-5695.	22	1.2451	-5977.
8	0.0022	-5698.	23	1.9669	-5977.
9	0.0025	-5731.	24	1.9957	-5988.
10	0.0028	-5797.	25	2.7204	-5988.
11	0.0030	-5831.	26	3.3504	-6000.
12	0.0033	-5864.	27	4.4870	-6005.
13	0.0036	-5855.	28	5.7065	-6011.
14	0.0039	-5932.	29	6.9570	-6004.
15	0.0042	-5911.	30	9.0410	-6008.
			31	11.5230	-6012.
			32	14.4406	-6003.
			33	18.1919	-6018.
			34	22.2552	-6041.
			35	28.0868	-6064.
			36	35.8780	-6078.
			37	45.0878	-6088.
			38	50.4193	-6094.

Specimen No. 8 - Step No. 6 - Initial Time = 237.231 Hours

STEP RESPONSE			RELAXATION		
	TIME (Hrs)	45 STRAIN (Micro)		TIME (Hrs)	45 STRAIN (Micro)
1	0.0001	606.	16	0.0064	661.
2	0.0004	603.	17	0.0167	665.
3	0.0007	615.	18	0.0639	661.
4	0.0010	626.	19	0.1589	665.
5	0.0014	623.	20	0.3812	661.
6	0.0016	638.	21	0.8198	653.
7	0.0019	638.	22	1.2451	653.
8	0.0022	649.	23	1.9669	654.
9	0.0025	649.	24	1.9957	649.
10	0.0028	649.	25	2.7204	638.
11	0.0030	661.	26	3.3504	649.
12	0.0033	665.	27	4.4870	645.
13	0.0036	673.	28	5.7065	649.
14	0.0039	673.	29	6.9570	649.
15	0.0042	669.	30	9.0410	651.
			31	11.5230	652.
			32	14.4406	652.
			33	18.1919	645.
			34	22.2552	638.
			35	28.0868	633.
			36	35.8780	632.
			37	45.0878	629.
			38	50.4193	626.

Specimen No. 8 - Step No. 7 - Initial Time = 288.177 Hours

STEP RESPONSE			RELAXATION		
	TIME (Hrs)	Ø STRAIN (Micro)		TIME (Hrs)	Ø STRAIN (Micro)
1	0.0006	7505.	15	0.0087	8193.
2	0.0009	7604.	16	0.0317	8238.
3	0.0011	7662.	17	0.1184	8226.
4	0.0014	7719.	18	0.3062	8238.
5	0.0019	7780.	19	0.5134	8227.
6	0.0022	7826.	20	0.9631	827.
7	0.0024	7915.	21	1.0353	82.
8	0.0027	7961.	22	1.6473	82.
9	0.0030	8019.	23	2.4095	82.
10	0.0033	8065.	24	3.5466	82.
11	0.0035	8078.	25	4.6860	82.
12	0.0038	8080.	26	5.5211	821.
13	0.0041	8158.	27	6.7715	8231.
14	0.0044	8249.	28	9.1676	8242.
			29	11.5188	8244.
			30	14.3651	8253.
			31	18.2092	8253.
			32	22.7966	8259.
			33	28.6340	8264.
			34	35.7205	8268.
			35	44.0568	8267.

Specimen No. 8 - Step No. 7 - Initial Time = 288.177 Hours

STEP RESPONSE			RELAXATION		
	TIME (Hrs)	STRESS (Ksi)		TIME (Hrs)	STRESS (Ksi)
1	0.0006	13.594	15	0.0087	15.361
2	0.0009	13.745	16	0.0317	15.296
3	0.0011	13.896	17	0.1184	15.231
4	0.0014	14.046	18	0.3062	15.188
5	0.0019	14.305	19	0.5134	15.145
6	0.0022	14.434	20	0.9631	15.102
7	0.0024	14.556	21	1.0353	15.102
8	0.0027	14.671	22	1.6473	15.016
9	0.0030	14.793	23	2.4095	14.994
10	0.0033	14.922	24	3.5466	14.942
11	0.0035	15.065	25	4.6860	14.879
12	0.0038	15.180	26	5.5211	14.865
13	0.0041	15.288	27	6.7715	14.830
14	0.0044	15.417	28	9.1676	14.753
			29	11.5188	14.686
			30	14.3651	14.612
			31	18.2092	14.537
			32	22.7966	14.481
			33	28.6340	14.415
			34	35.7205	14.333
			35	44.0568	14.219



Specimen No. 8 - Step No. 7 - Initial Time = 288.177 Hours

STEP RESPONSE			RELAXATION		
	TIME (Hrs)	90 STRAIN (Micro)		TIME (Hrs)	90 STRAIN (Micro)
1	0.0006	-6146.	15	0.0087	-6640.
2	0.0009	-6225.	16	0.0317	-6688.
3	0.0011	-6259.	17	0.1184	-6688.
4	0.0014	-6304.	18	0.3062	-6688.
5	0.0019	-6372.	19	0.5134	-6688.
6	0.0022	-6406.	20	0.9631	-6699.
7	0.0024	-6440.	21	1.0353	-6651.
8	0.0027	-6485.	22	1.6473	-6722.
9	0.0030	-6472.	23	2.4095	-6722.
10	0.0033	-6505.	24	3.5466	-6705.
11	0.0035	-6528.	25	4.6860	-6733.
12	0.0038	-6561.	26	5.5211	-6707.
13	0.0041	-6606.	27	6.7715	-6727.
14	0.0044	-6640.	28	9.1676	-6732.
			29	11.5188	-6739.
			30	14.3651	-6752.
			31	18.2092	-6785.
			32	22.7966	-6821.
			33	28.6340	-6852.
			34	35.7205	-6854.
			35	44.0568	-6820.

Specimen No. 8 - Step No. 7 - Initial Time = 288.177 Hours

STEP RESPONSE			RELAXATION		
	TIME (Hrs)	45 STRAIN (Micro)		TIME (Hrs)	45 STRAIN (Micro)
1	0.0006	634.	15	0.0087	704.
2	0.0009	638.	16	0.0317	696.
3	0.0011	638.	17	0.1184	684.
4	0.0014	649.	18	0.3062	692.
5	0.0019	658.	19	0.5134	684.
6	0.0022	661.	20	0.9631	684.
7	0.0024	673.	21	1.0353	684.
8	0.0027	673.	22	1.6473	673.
9	0.0030	684.	23	2.4095	673.
10	0.0033	692.	24	3.5466	677.
11	0.0035	692.	25	4.6860	673.
12	0.0038	704.	26	5.5211	673.
13	0.0041	715.	27	6.7715	667.
14	0.0044	715.	28	9.1676	666.
			29	11.5188	659.
			30	14.3651	650.
			31	18.2092	640.
			32	22.7966	634.
			33	28.6340	631.
			34	35.7205	633.
			35	44.0568	638.

Specimen No. 8 - Step No. 8 - Initial Time = 336.492 Hours

STEP RESPONSE			RELAXATION		
	TIME (Hrs)	Ø STRAIN (Micro)		TIME (Hrs)	Ø STRAIN (Micro)
1	0.0002	8307.	16	0.0076	9113.
2	0.0005	8376.	17	0.0169	9152.
3	0.0008	8468.	18	0.0640	9102.
4	0.0010	8491.	19	0.1576	9090.
5	0.0013	8536.	20	0.3457	9141.
6	0.0016	8594.	21	0.6393	9090.
7	0.0019	8640.	22	1.0532	9102.
8	0.0024	8779.	23	1.6554	9113.
9	0.0026	8825.	24	2.2130	9113.
10	0.0029	8883.	25	2.9830	9113.
11	0.0032	8929.	26	3.8534	9112.
12	0.0035	8975.	27	4.3458	9114.
13	0.0037	9021.	28	5.8765	9128.
14	0.0040	9018.	29	7.5224	9123.
15	0.0043	9075.	30	9.1896	9114.
			31	11.2139	9100.
			32	14.1317	9099.
			33	17.8829	9112.
			34	22.4689	9120.
			35	28.4840	9135.
			36	35.9879	9142.
			37	43.8624	9144.

Specimen No. 8 - Step No. 8 - Initial Time = 336.492 Hours

STEP RESPONSE			RELAXATION		
	TIME (Hrs)	STRESS (Ksi)		TIME (Hrs)	STRESS (Ksi)
1	0.0002	14.319	16	0.0076	16.265
2	0.0005	14.491	17	0.0169	16.201
3	0.0008	14.621	18	0.0640	16.149
4	0.0010	14.793	19	0.1576	16.071
5	0.0013	14.951	20	0.3457	16.028
6	0.0016	15.073	21	0.6393	15.964
7	0.0019	15.224	22	1.0532	15.929
8	0.0024	15.447	23	1.6554	15.848
9	0.0026	15.568	24	2.2130	15.813
10	0.0029	15.727	25	2.9830	15.770
11	0.0032	15.826	26	3.8534	15.698
12	0.0035	15.934	27	4.3458	15.664
13	0.0037	16.042	28	5.8765	15.587
14	0.0040	16.193	29	7.5224	15.515
15	0.0043	16.292	30	9.1896	15.441
			31	11.2139	15.368
			32	14.1317	15.278
			33	17.8829	15.197
			34	22.4689	15.110
			35	28.4840	15.004
			36	35.9879	14.887
			37	43.8624	14.783

Specimen No. 8 - Step No. 8 - Initial Time = 336.492 Hours

STEP RESPONSE			RELAXATION		
	TIME (Hrs)	90 STRAIN (Micro)		TIME (Hrs)	90 STRAIN (Micro)
1	0.0002	-6853.	16	0.0076	-7432.
2	0.0005	-6849.	17	0.0169	-7432.
3	0.0008	-6932.	18	0.0640	-7432.
4	0.0010	-6965.	19	0.1576	-7432.
5	0.0013	-7021.	20	0.3457	-7443.
6	0.0016	-7044.	21	0.6393	-7455.
7	0.0019	-7128.	22	1.0532	-7414.
8	0.0024	-7156.	23	1.6554	-7466.
9	0.0026	-7190.	24	2.2130	-7477.
10	0.0029	-7263.	25	2.9830	-7488.
11	0.0032	-7257.	26	3.8534	-7492.
12	0.0035	-7331.	27	4.3458	-7492.
13	0.0037	-7313.	28	5.8765	-7528.
14	0.0040	-7347.	29	7.5224	-7520.
15	0.0043	-7380.	30	9.1896	-7531.
			31	11.2139	-7513.
			32	14.1317	-7537.
			33	17.8829	-7563.
			34	22.4689	-7588.
			35	28.4840	-7602.
			36	35.9879	-7604.
			37	43.8624	-7600.

Specimen No. 8 - Step No. 8 - Initial Time = 336.492 Hours

STEP RESPONSE			RELAXATION		
	TIME (Hrs)	45 STRAIN (Micro)		TIME (Hrs)	45 STRAIN (Micro)
1	0.0002	646.	16	0.0076	727.
2	0.0005	658.	17	0.0169	719.
3	0.0008	658.	18	0.0640	719.
4	0.0010	665.	19	0.1576	715.
5	0.0013	669.	20	0.3457	707.
6	0.0016	669.	21	0.6393	707.
7	0.0019	681.	22	1.0532	704.
8	0.0024	696.	23	1.6554	707.
9	0.0026	692.	24	2.2130	707.
10	0.0029	704.	25	2.9830	704.
11	0.0032	704.	26	3.8534	704.
12	0.0035	715.	27	4.3458	704.
13	0.0037	719.	28	5.8765	697.
14	0.0040	727.	29	7.5224	695.
15	0.0043	734.	30	9.1896	692.
			31	11.2139	686.
			32	14.1317	678.
			33	17.8829	670.
			34	22.4689	667.
			35	28.4840	667.
			36	35.9879	663.
			37	43.8624	655.

Specimen No. 8 - Step No. 9 - Initial Time = 383.833 Hours

STEP RESPONSE			RELAXATION		
	TIME (Hrs)	Ø STRAIN (Micro)		TIME (Hrs)	Ø STRAIN (Micro)
1	0.0001	9190.	16	0.0061	10000.
2	0.0004	9247.	17	0.0180	9946.
3	0.0007	9355.	18	0.0422	9989.
4	0.0009	9413.	19	0.1411	10044.
5	0.0012	9471.	20	0.3044	10044.
6	0.0017	9522.	21	0.7016	10000.
7	0.0020	9579.	22	1.0358	10012.
8	0.0023	9595.	23	1.5594	10000.
9	0.0026	9694.	24	2.0741	10012.
10	0.0028	9740.	25	2.6849	10024.
11	0.0031	9839.	26	3.2511	10024.
12	0.0034	9843.	27	4.3866	10026.
13	0.0037	9889.	28	5.5097	10024.
14	0.0040	9934.	29	6.9876	10023.
15	0.0042	9969.	30	8.7979	10042.
			31	10.9326	10053.
			32	14.1480	10057.
			33	17.5524	10061.
			34	22.2945	10061.
			35	28.4755	10072.
			36	35.7323	10080.
			37	45.0674	10091.
			38	56.7383	10091.
			39	66.3250	10088.

Specimen No. 8 - Step No. 9 - Initial Time = 383.833 Hours

STEP RESPONSE			RELAXATION		
	TIME (Hrs)	STRESS (Ksi)		TIME (Hrs)	STRESS (Ksi)
1	0.0001	14.944	16	0.0061	16.925
2	0.0004	15.108	17	0.0180	16.851
3	0.0007	15.267	18	0.0422	16.817
4	0.0009	15.396	19	0.1411	16.731
5	0.0012	15.568	20	0.3044	16.696
6	0.0017	15.848	21	0.7016	16.653
7	0.0020	15.999	22	1.0358	16.567
8	0.0023	16.141	23	1.5594	16.502
9	0.0026	16.249	24	2.0741	16.459
10	0.0028	16.400	25	2.6849	16.416
11	0.0031	16.515	26	3.2511	16.373
12	0.0034	16.666	27	4.3866	16.307
13	0.0037	16.765	28	5.5097	16.251
14	0.0040	16.873	29	6.9876	16.179
15	0.0042	16.981	30	8.7979	16.095
			31	10.9326	16.008
			32	14.1480	15.905
			33	17.5524	15.820
			34	22.2945	15.730
			35	28.4755	15.648
			36	35.7323	15.552
			37	45.0674	15.444
			38	56.7383	15.318
			39	66.3250	15.236

Specimen No. 8 - Step No. 9 - Initial Time = 383.833 Hours

STEP RESPONSE			RELAXATION		
	TIME (Hrs)	90 STRAIN (Micro)		TIME (Hrs)	90 STRAIN (Micro)
1	0.0001	-7661.	16	0.0061	-8244.
2	0.0004	-7705.	17	0.0180	-8188.
3	0.0007	-7739.	18	0.0422	-8244.
4	0.0009	-7838.	19	0.1411	-8255.
5	0.0012	-7861.	20	0.3044	-8255.
6	0.0017	-7896.	21	0.7016	-8267.
7	0.0020	-7930.	22	1.0358	-8278.
8	0.0023	-7963.	23	1.5594	-8289.
9	0.0026	-7997.	24	2.0741	-8289.
10	0.0028	-8031.	25	2.6849	-8300.
11	0.0031	-8076.	26	3.2511	-8323.
12	0.0034	-8109.	27	4.3866	-8310.
13	0.0037	-8143.	28	5.5097	-8309.
14	0.0040	-8177.	29	6.9876	-8326.
15	0.0042	-8188.	30	8.7979	-8344.
			31	10.9326	-8359.
			32	14.1480	-8375.
			33	17.5524	-8386.
			34	22.2945	-8397.
			35	28.4755	-8407.
			36	35.7323	-8421.
			37	45.0674	-8444.
			38	56.7383	-8456.
			39	66.3250	-8456.

Specimen No. 8 - Step No. 9 - Initial Time = 383.833 Hours

STEP RESPONSE			RELAXATION		
	TIME (Hrs)	45 STRAIN (Micro)		TIME (Hrs)	45 STRAIN (Micro)
1	0.0001	646.	16	0.0061	734.
2	0.0004	665.	17	0.0180	734.
3	0.0007	665.	18	0.0422	727.
4	0.0009	669.	19	0.1411	715.
5	0.0012	677.	20	0.3044	719.
6	0.0017	688.	21	0.7016	715.
7	0.0020	700.	22	1.0358	715.
8	0.0023	711.	23	1.5594	719.
9	0.0026	711.	24	2.0741	715.
10	0.0028	723.	25	2.6849	704.
11	0.0031	715.	26	3.2511	707.
12	0.0034	723.	27	4.3866	707.
13	0.0037	734.	28	5.5097	708.
14	0.0040	750.	29	6.9876	707.
15	0.0042	746.	30	8.7979	705.
			31	10.9326	697.
			32	14.1480	687.
			33	17.5524	677.
			34	22.2945	668.
			35	28.4755	666.
			36	35.7323	668.
			37	45.0674	671.
			38	56.7383	670.
			39	66.3250	667.

Specimen No. 8 - Step No. 10 - Initial Time = 453.707 Hours

STEP RESPONSE			RELAXATION		
	TIME (Hrs)	Ø STRAIN (Micro)		TIME (Hrs)	Ø STRAIN (Micro)
1	0.0006	10152.	14	0.0225	10945.
2	0.0009	10300.	15	0.0786	10994.
3	0.0012	10346.	16	0.2878	11006.
4	0.0015	10358.	17	0.6992	10957.
5	0.0018	10416.	18	1.2945	10957.
6	0.0020	10519.	19	1.7628	10957.
7	0.0023	10577.	20	2.4159	10957.
8	0.0026	10634.	21	3.2495	11040.
9	0.0029	10692.	22	4.2451	10990.
10	0.0032	10809.	23	5.5319	10984.
11	0.0034	10807.	24	6.9313	11006.
12	0.0039	10899.	25	8.9733	11015.
13	0.0042	10885.	26	10.9455	11011.
			27	14.1922	10998.
			28	18.9345	10988.
			29	21.7248	10992.
			30	28.9721	11006.
			31	34.5649	11008.
			32	43.8061	10992.

Specimen No. 8 - Step No. 10 - Initial Time = 453.707 Hours

STEP RESPONSE			RELAXATION		
	TIME (Hrs)	STRESS (Ksi)		TIME (Hrs)	STRESS (Ksi)
1	0.0006	15.417	14	0.0225	17.299
2	0.0009	15.654	15	0.0786	17.213
3	0.0012	15.783	16	0.2878	17.192
4	0.0015	15.956	17	0.6992	17.106
5	0.0018	16.093	18	1.2945	17.075
6	0.0020	16.236	19	1.7628	16.998
7	0.0023	16.408	20	2.4159	16.976
8	0.0026	16.567	21	3.2495	16.903
9	0.0029	16.709	22	4.2451	16.855
10	0.0032	16.860	23	5.5319	16.782
11	0.0034	16.989	24	6.9313	16.713
12	0.0039	17.226	25	8.9733	16.628
13	0.0042	17.346	26	10.9455	16.564
			27	14.1922	16.466
			28	18.9345	16.347
			29	21.7248	16.302
			30	28.9721	16.230
			31	34.5649	16.179
			32	43.8061	16.060

Specimen No. 8 - Step No. 10 - Initial Time = 453.707 Hours

STEP RESPONSE			RELAXATION		
	TIME (Hrs)	90 STRAIN (Micro)		TIME (Hrs)	90 STRAIN (Micro)
1	0.0006	-8513.	14	0.0225	-9090.
2	0.0009	-8569.	15	0.0786	-9101.
3	0.0012	-8614.	16	0.2878	-9112.
4	0.0015	-8695.	17	0.6992	-9112.
5	0.0018	-8740.	18	1.2945	-9124.
6	0.0020	-8797.	19	1.7628	-9135.
7	0.0023	-8830.	20	2.4159	-9146.
8	0.0026	-8876.	21	3.2495	-9146.
9	0.0029	-8909.	22	4.2451	-9149.
10	0.0032	-8943.	23	5.5319	-9171.
11	0.0034	-8988.	24	6.9313	-9197.
12	0.0039	-9045.	25	8.9733	-9211.
13	0.0042	-9029.	26	10.9455	-9199.
			27	14.1922	-9193.
			28	18.9345	-9203.
			29	21.7248	-9211.
			30	28.9721	-9231.
			31	34.5649	-9242.
			32	43.8061	-9269.

Specimen No. 8 - Step No. 10 - Initial Time = 453.707 Hours

STEP RESPONSE			RELAXATION		
	TIME (Hrs)	45 STRAIN (Micro)		TIME (Hrs)	45 STRAIN (Micro)
1	0.0006	669.	14	0.0225	742.
2	0.0009	688.	15	0.0786	738.
3	0.0012	688.	16	0.2878	742.
4	0.0015	704.	17	0.6992	738.
5	0.0018	692.	18	1.2945	738.
6	0.0020	704.	19	1.7628	727.
7	0.0023	704.	20	2.4159	731.
8	0.0026	715.	21	3.2495	727.
9	0.0029	727.	22	4.2451	725.
10	0.0032	734.	23	5.5319	723.
11	0.0034	734.	24	6.9313	720.
12	0.0039	746.	25	8.9733	717.
13	0.0042	746.	26	10.9455	713.
			27	14.1922	706.
			28	18.9345	695.
			29	21.7248	692.
			30	28.9721	687.
			31	34.5649	682.
			32	43.8061	664.

Specimen No. 8 - Step No. 11 - Initial Time = 501.828 Hours

STEP RESPONSE			RELAXATION		
	TIME (Hrs)	Ø STRAIN (Micro)		TIME (Hrs)	Ø STRAIN (Micro)
1	0.0002	11060.	16	0.0118	11855.
2	0.0005	11118.	17	0.0212	11844.
3	0.0008	11176.	18	0.0795	11832.
4	0.0011	11233.	19	0.1453	11844.
5	0.0014	11291.	20	0.2245	11898.
6	0.0018	11321.	21	0.2933	11839.
7	0.0020	11441.	22	0.3602	11809.
8	0.0023	11487.	23	0.4327	11805.
9	0.0026	11544.	24	0.5698	11802.
10	0.0029	11602.	25	0.7119	11791.
11	0.0032	11660.	26	0.8764	11772.
12	0.0034	11717.	27	1.1736	11788.
13	0.0037	11763.	28	1.4578	11821.
14	0.0040	11745.	29	1.8466	11800.
15	0.0043	11855.	30	2.2757	11767.
			31	2.8525	11717.
			32	3.6099	11690.
			33	4.2497	11678.
			34	5.5017	11671.
			35	7.2333	11686.
			36	8.4923	11688.
			37	11.3373	11711.
			38	14.4719	11714.
			39	18.2178	11719.
			40	23.2889	11712.
			41	28.2475	11716.
			42	35.9111	11734.
			43	44.5717	11745.



Specimen No. 8 - Step No. 11 - Initial Time = 501.828 Hours

STEP RESPONSE			RELAXATION		
	TIME (Hrs)	STRESS (Ksi)		TIME (Hrs)	STRESS (Ksi)
1	0.0002	16.128	16	0.0118	18.174
2	0.0005	16.287	17	0.0212	18.118
3	0.0008	16.438	18	0.0795	18.066
4	0.0011	16.589	19	0.1453	18.053
5	0.0014	16.731	20	0.2245	18.001
6	0.0018	16.955	21	0.2933	18.004
7	0.0020	17.127	22	0.3602	17.996
8	0.0023	17.269	23	0.4327	17.974
9	0.0026	17.420	24	0.5698	17.931
10	0.0029	17.571	25	0.7119	17.895
11	0.0032	17.721	26	0.8764	17.869
12	0.0034	17.851	27	1.1736	17.839
13	0.0037	18.001	28	1.4578	17.816
14	0.0040	18.109	29	1.8466	17.770
15	0.0043	18.217	30	2.2757	17.732
			31	2.8525	17.673
			32	3.6099	17.608
			33	4.2497	17.561
			34	5.5017	17.502
			35	7.2333	17.437
			36	8.4923	17.392
			37	11.3373	17.305
			38	14.4719	17.207
			39	18.2178	17.103
			40	23.2889	16.997
			41	28.2475	16.934
			42	35.9111	16.846
			43	44.5717	16.743

Specimen No. 8 - Step No. 11 - Initial Time = 501.828 Hours

STEP RESPONSE

RELAXATION

STEP RESPONSE			RELAXATION		
	TIME (Hrs)	90 STRAIN (Micro)		TIME (Hrs)	90 STRAIN (Micro)
1	0.0002	-9401.	16	0.0118	-9902.
2	0.0005	-9383.	17	0.0212	-9957.
3	0.0008	-9428.	18	0.0795	-9902.
4	0.0011	-9462.	19	0.1453	-9902.
5	0.0014	-9507.	20	0.2245	-9913.
6	0.0018	-9564.	21	0.2933	-9890.
7	0.0020	-9609.	22	0.3602	-9881.
8	0.0023	-9642.	23	0.4327	-9885.
9	0.0026	-9676.	24	0.5698	-9879.
10	0.0029	-9721.	25	0.7119	-9888.
11	0.0032	-9809.	26	0.8764	-9882.
12	0.0034	-9854.	27	1.1736	-9906.
13	0.0037	-9823.	28	1.4578	-9936.
14	0.0040	-9857.	29	1.8466	-9905.
15	0.0043	-9891.	30	2.2757	-9903.
			31	2.8525	-9909.
			32	3.6099	-9917.
			33	4.2497	-9921.
			34	5.5017	-9919.
			35	7.2333	-9890.
			36	8.4923	-9871.
			37	11.3373	-9839.
			38	14.4719	-9835.
			39	18.2178	-9861.
			40	23.2889	-9880.
			41	28.2475	-9900.
			42	35.9111	-9930.
			43	44.5717	-9947.

Specimen No. 8 - Step No. 11 - Initial Time = 501.828 Hours

STEP RESPONSE			RELAXATION		
	TIME (Hrs)	45 STRAIN (Micro)		TIME (Hrs)	45 STRAIN (Micro)
1	0.0002	669.	16	0.0118	750.
2	0.0005	669.	17	0.0212	738.
3	0.0008	669.	18	0.0795	738.
4	0.0011	681.	19	0.1453	738.
5	0.0014	681.	20	0.2245	738.
6	0.0018	704.	21	0.2933	737.
7	0.0020	704.	22	0.3602	736.
8	0.0023	700.	23	0.4327	734.
9	0.0026	715.	24	0.5698	732.
10	0.0029	727.	25	0.7119	729.
11	0.0032	727.	26	0.8764	727.
12	0.0034	738.	27	1.1736	725.
13	0.0037	738.	28	1.4578	723.
14	0.0040	746.	29	1.8466	720.
15	0.0043	746.	30	2.2757	719.
			31	2.8525	719.
			32	3.6099	719.
			33	4.2497	719.
			34	5.5017	718.
			35	7.2333	715.
			36	8.4923	712.
			37	11.3373	709.
			38	14.4719	705.
			39	18.2178	698.
			40	23.2889	689.
			41	28.2475	687.
			42	35.9111	679.
			43	44.5717	668.

Specimen No. 8 - Step No. 12 - Initial Time = 550.008 Hours

STEP RESPONSE

RELAXATION

	TIME (Hrs)	Ø STRAIN (Micro)		TIME (Hrs)	Ø STRAIN (Micro)
1	0.0005	11806.	15	0.0087	12536.
2	0.0008	11799.	16	0.0262	12593.
3	0.0010	11856.	17	0.0732	12536.
4	0.0013	11901.	18	0.1598	12468.
5	0.0016	12034.	19	0.2504	12536.
6	0.0019	12026.	20	0.4344	12524.
7	0.0022	12071.	21	0.5603	12497.
8	0.0024	12139.	22	0.7094	12501.
9	0.0027	12196.	23	0.8837	12484.
10	0.0032	12342.	24	1.0469	12504.
11	0.0034	12343.	25	1.3426	12510.
12	0.0037	12400.	26	1.7193	12536.
13	0.0040	12501.	27	2.2783	12509.
14	0.0043	12491.	28	2.7441	12502.
			29	3.5162	12553.
			30	4.3679	12629.
			31	5.8609	12702.
			32	6.8563	12743.
			33	8.8534	12745.
			34	11.8692	12752.
			35	14.3936	12743.
			36	17.3356	12739.
			37	22.4258	12706.
			38	26.1439	12674.
			39	26.5817	12034.
			40	26.6046	11057.
			41	26.6481	10530.
			42	26.6573	4057.
			43	33.9969	3035.

Specimen No. 8 - Step No. 12 - Initial Time = 550.008 Hours

STEP RESPONSE			RELAXATION			
	TIME (Hrs)	STRESS (Ksi)		TIME (Hrs)	STRESS (Ksi)	
	1	0.0005	16.838	15	0.0087	18.776
	2	0.0008	16.989	16	0.0262	18.733
	3	0.0010	17.140	17	0.0732	18.700
	4	0.0013	17.291	18	0.1598	18.659
	5	0.0016	17.463	19	0.2504	18.635
	6	0.0019	17.614	20	0.4344	18.592
	7	0.0022	17.743	21	0.5603	18.577
	8	0.0024	17.915	22	0.7094	18.555
	9	0.0027	18.066	23	0.8837	18.537
	10	0.0032	18.303	24	1.0469	18.514
	11	0.0034	18.453	25	1.3426	18.477
	12	0.0037	18.583	26	1.7193	18.420
	13	0.0040	18.743	27	2.2783	18.386
	14	0.0043	18.853	28	2.7441	18.356
				29	3.5162	18.312
				30	4.2259	18.277
				31	4.3512	18.281
				32	4.3519	18.463
				33	4.3528	18.809
				34	4.5619	18.774
				35	5.8609	18.630
				36	6.8563	18.529
				37	8.8534	18.372
				38	11.8692	18.148
				39	14.3936	17.997
				40	17.3356	17.868
				41	22.4258	17.692
				42	27.0310	17.565
				43	35.6131	17.385
				44	45.0346	17.192

Specimen No. 8 - Step No. 12 - Initial Time = 550.008 Hours

STEP RESPONSE

RELAXATION

	TIME (Hrs)	90 STRAIN (Micro)		TIME (Hrs)	90 STRAIN (Micro)
1	0.0005	-9984.	15	0.0087	-10497.
2	0.0008	-9963.	16	0.0262	-10508.
3	0.0010	-10051.	17	0.0732	-10508.
4	0.0013	-10095.	18	0.1598	-10508.
5	0.0016	-10074.	19	0.2504	-10508.
6	0.0019	-10173.	20	0.4344	-10519.
7	0.0022	-10207.	21	0.5603	-10532.
8	0.0024	-10196.	22	0.7094	-10525.
9	0.0027	-10241.	23	0.8837	-10513.
10	0.0032	-10420.	24	1.0469	-10515.
11	0.0034	-10397.	25	1.3426	-10544.
12	0.0037	-10441.	26	1.7193	-10657.
13	0.0040	-10486.	27	2.2783	-10583.
14	0.0043	-10566.	28	2.7441	-10544.
			29	3.5162	-10571.
			30	4.3679	-10631.
			31	5.8609	-10707.
			32	6.8563	-10747.
			33	8.8534	-10766.
			34	11.8692	-10796.
			35	14.3936	-10818.
			36	17.3356	-10834.
			37	22.4258	-10637.
			38	26.1439	-10340.
			39	26.5811	-9602.
			40	26.5820	-8760.
			41	26.5985	-8066.
			42	26.6478	-7545.
			43	26.7571	-4295.
			44	36.0126	-3592.

Specimen No. 8 - Step No. 12 - Initial Time = 550.000 Hours

STEP RESPONSE			RELAXATION		
	TIME (Hrs)	45 STRAIN (Micro)		TIME (Hrs)	45 STRAIN (Micro)
1	0.0005	681.	15	0.0087	746.
2	0.0008	677.	16	0.0262	750.
3	0.0010	688.	17	0.0732	738.
4	0.0013	692.	18	0.1598	746.
5	0.0016	700.	19	0.2504	750.
6	0.0019	700.	20	0.4344	738.
7	0.0022	723.	21	0.5603	743.
8	0.0024	723.	22	0.7094	744.
9	0.0027	723.	23	0.8837	744.
10	0.0032	727.	24	1.0469	743.
11	0.0034	738.	25	1.3426	744.
12	0.0037	750.	26	1.7193	742.
13	0.0040	750.	27	2.2783	737.
14	0.0043	750.	28	2.7441	736.
			29	3.5162	737.
			30	4.3679	740.
			31	5.8609	743.
			32	6.8563	745.
			33	8.8534	734.
			34	11.8692	717.
			35	14.3936	707.
			36	17.3356	697.
			37	22.4258	664.
			38	26.1439	626.
			39	26.5984	495.
			40	26.6481	493.
			41	34.1193	21.

END

FILMED

74

D TIC