

AD

TECHNICAL REPORT ARLCB-TR-83044

MAGNETIC BEHAVIOR OF PRESSURE QUENCHED CADMIUM SULFIDE CONTAINING CHLORINE

AD-A141 447

P. J. COTE

S. BLOCK

C. G. HOMAN

G. P. PIERMARINI

W. C. MOFFATT

R. K. MacCRONE

NOVEMBER 1983



US ARMY ARMAMENT RESEARCH AND DEVELOPMENT CENTER
LARGE CALIBER WEAPON SYSTEMS LABORATORY
BENET WEAPONS LABORATORY
WATERVLIET N.Y. 12189

APPROVED FOR PUBLIC RELEASE; DISTRIBUTION UNLIMITED

DISCLAIMER

The findings in this report are not to be construed as an official Department of the Army position unless so designated by other authorized documents.

The use of trade name(s) and/or manufacture(s) does not constitute an official indorsement or approval.

DISPOSITION

Destroy this report when it is no longer needed. Do not return it to the originator.

REPORT DOCUMENTATION PAGE		READ INSTRUCTIONS BEFORE COMPLETING FORM
1. REPORT NUMBER ARLCB-TR-83044	2. GOVT ACCESSION NO.	3. RECIPIENT'S CATALOG NUMBER
4. TITLE (and Subtitle) MAGNETIC BEHAVIOR OF PRESSURE QUENCHED CADMIUM SULFIDE CONTAINING CHLORINE		5. TYPE OF REPORT & PERIOD COVERED Final
		6. PERFORMING ORG. REPORT NUMBER
7. AUTHOR(s) P. J. Cote, C. G. Homan, W. C. Moffatt, S. Block, G. P. Piermarini, and R. K. MacCrone (SEE REVERSE SIDE)		8. CONTRACT OR GRANT NUMBER(s) AFOSR Contract No. 79-0126 ONR Contract No. N00014-80-C-0828
9. PERFORMING ORGANIZATION NAME AND ADDRESS US Army Armament Research & Development Center Benet Weapons Laboratory, DRSMC-LCB-TL Watervliet, NY 12189		10. PROGRAM ELEMENT, PROJECT, TASK AREA & WORK UNIT NUMBERS AMCMS No. 6111.02.H600.011 PRON No. 1A325B541A1A
11. CONTROLLING OFFICE NAME AND ADDRESS US Army Armament Research & Development Center Large Caliber Weapon Systems Laboratory Dover, NJ 07801		12. REPORT DATE November 1983
		13. NUMBER OF PAGES 28
14. MONITORING AGENCY NAME & ADDRESS (if different from Controlling Office)		15. SECURITY CLASS. (of this report) UNCLASSIFIED
		15a. DECLASSIFICATION/DOWNGRADING SCHEDULE
16. DISTRIBUTION STATEMENT (of this Report) Approved for public release; distribution unlimited.		
17. DISTRIBUTION STATEMENT (of the abstract entered in Block 20, if different from Report)		
18. SUPPLEMENTARY NOTES Presented at IX AIRAPT International High Pressure Conference, Albany, NY, 26 July 1983. Submitted to the journal, <u>Physical Review</u> .		
19. KEY WORDS (Continue on reverse side if necessary and identify by block number) CdS _{2x} Cl _{2-x} Pressure Quenched Diamagnetism Paramagnetism Superconductivity		
20. ABSTRACT (Continue on reverse side if necessary and identify by block number) Pressure quenched cadmium sulfide (CdS) containing chlorine (Cl) has been shown previously to exhibit both very large diamagnetism and paramagnetism. The diamagnetism observed at 77K approached Meissner proportion and suggested superconducting like behavior in this material. The effect is known to depend sensitively on the Cl content of the starting material. This report describes the results of a survey of the magnetic behavior of pressure quenched samples (CONT'D ON REVERSE)		

7. AUTHOR(S) (CONT'D)

S. Block and G. P. Piermarini
National Bureau of Standards
Washington, D.C.

R. K. MacCrone
Rensselaer Polytechnic Institute
Troy, NY

20. ABSTRACT (CONT'D)

prepared from CdS systematically doped with increasing amounts of Cl.

The Cl doped material was prepared in a variety of ways: from mixtures of CdS and CdCl₂, by precipitation from aqueous solution, and by acid doping. The differently doped starting materials were analyzed for Cl and other impurities before being pressure quenched. The magnetic susceptibilities were subsequently measured.

The results of the survey indicate that the concentration of Cl required to produce specimens with anomalously large magnetism is 0.75 ± 0.10 weight percent. The technique for the preparation of such material is described.

TABLE OF CONTENTS

	<u>Page</u>
INTRODUCTION	1
CHEMICAL ANALYSIS OF AS RECEIVED CdS MATERIALS	3
PREPARATION OF Cl DOPED CdS MATERIALS	5
a. Mixtures of CdS and CdCl ₂ Powders	5
b. Precipitation Reaction	5
ACID DOPING TECHNIQUE	8
MAGNETIC MEASUREMENTS	9
PLATELET VOLUME MEASUREMENTS	13
DISCUSSION OF EXPERIMENTAL RESULTS	15
DISCUSSION	16
CONCLUSION	18
REFERENCES	19

TABLES

I. DIAMAGNETIC AND PARAMAGNETIC SUSCEPTIBILITIES OF PRESSURE QUENCHED CdS CONTAINING Cl	11
---	----

LIST OF ILLUSTRATIONS

1. Variation of ionic species present in aqueous solution of CdCl ₂ as a function of the molarity of solution based on [Cl ⁻] chloride ion concentration in moles/liters.	21
2. Mean value of the absolute magnetic volume susceptibility from each sample lot is plotted as a function of the nominal Cl content of the lot. Solid symbols represent the mean value determined from 10 or more observations on a particular sample lot as tabulated in Table I. Of the 115 observations represented in this figure, all but nine measurements which were measured at LHe temperatures in either the SQUID or ac magnetometers, were measured at LN ₂ temperatures.	22

	<u>Page</u>
3. Schematic of the sample chamber of the vibrating sample magnetometer, VSM. A Helitran cryogenic cooling system was used to provide the LN ₂ measurement temperatures.	23
4. Schematic of SQUID magnetometer used at LHe temperatures. A typical signal generated as the sample is drawn through the sense coils is shown at right.	24
5. Volume fraction of NaCl phase (platelets) retained after pressure quenching is plotted as a function of the nominal Cl content.	25

ACKNOWLEDGEMENTS

We would like to acknowledge the following persons for their aid in performing this survey: Mrs. T. V. Brassard for metallographic preparation and L. McNamara for SEM analysis at Benet Weapons Laboratory; W. Koch for the chemical analysis, H. Parker for the solid state sintering studies, F. Brinckman for suggesting the Cl complex formation analysis, and R. Munro for calculating the species concentrations at NBS; and S. Bilodeau and K. Laojindanpun for their aid in performing the magnetic measurements at RPI.

INTRODUCTION

Recently, dc flux exclusion approaching Meissner proportions in pressure quenched CdS materials at 77K was reported.¹ Corroboration of these results was provided by the work of Nam et al² who found strong ac diamagnetism in several samples of CdS materials that had also been rapidly pressure quenched. Cuprous chloride displayed similar diamagnetism after being subjected to rapid temperature variations while under pressure.³

Several theoretical models have been proposed to explain this anomalous diamagnetic behavior including surface superconductivity,⁴ pairing of holes in semiconductors,² finite momentum pair binding in a one-dimensional system,⁵ and an excitonic mechanism for superconductivity related to the presence of impurities.⁶

In the magnetically active CdS materials, it was also found that anomalous and very large paramagnetism occurred in some of the pressure quenched samples.⁷ The most recent work^{8,9} describes the simultaneous decrease of both the ac and dc electrical conductivity with the loss of flux exclusion, which supports the claim of some form of collective behavior in such materials. Both the anomalous diamagnetism and paramagnetism were found to be metastable.¹⁰ The magnetically active samples had a morphology of lenticular platelets embedded in a polycrystalline matrix¹¹ and contained a mixture of wurtzite (Greenockite), zinc blende (Hawleyite), and sodium chloride (NaCl) crystal structures. The magnetic effects were also found to be dependent on sample material origin and chemistry.^{1,7-10}

References are listed at the end of this report.

In all the previous work published by the present authors, these unusual electrical and magnetic properties were observed in samples made from a single lot of commercial high purity CdS powders obtained from Alpha Inorganic (AI) material, and only after rapid pressure quenching ($> 10^5$ bars/sec) from above the well-known wurtzite to NaCl phase transition at ambient temperatures.¹² These anomalous phenomena were never observed in samples made from any source other than the particular lot from Alpha Inorganics or in any samples which were slow quenched from above the high pressure transition.

It is thus clear that the anomalous behavior depends on both the sample chemistry and pressurization parameters. Here we describe our investigation of the chemistry of the as received materials used in the previous work and identify the critical chemistry involved in the phenomena. This chemistry was determined by the correlation of the electrical and magnetic properties with the sample impurities and dopants of both as received and prepared materials. We describe material preparation techniques which provided samples giving similar anomalous results after pressure quenching. We also report other physical properties which depend on the sample chemistry and the resulting morphology of the pressure quenched samples.

The implications of these material studies are discussed. A tentative model relating to metastable phase decomposition (NaCl phase) is suggested to explain the correlation between sample chemistry and morphological behavior after various pressure treatments.

CHEMICAL ANALYSIS OF AS RECEIVED CdS MATERIALS

A qualitative analysis of the magnetically active Alpha Inorganic (AI) and non-active Eagle Picher (EP) materials by a spark emission technique did not show any appreciable difference in the metallic impurity spectrum.¹⁰ Thus, a more comprehensive chemical analysis was performed by National Bureau of Standards (NBS) on these materials and on other magnetically non-active sample materials.

Initially, a qualitative evaluation by x-ray fluorescence (XRF) was made using both energy and wavelength dispersive spectrometers. This technique has detection limits of the order of 1-10 ppm for all elements $Z > 11$. Trace elements Cl, K, Fe, Cu, Zn, and Ge were detected near the limit of detection by XRF in the magnetically active Alpha Inorganic material suggesting that impurity levels were of the order of 10 ppm.¹

Both pressed starting pellets and pressure quenched samples of the various as received materials were further analyzed by electron probe micro-analysis with dispersive x-ray spectrometry (EDS). In general, this technique is sensitive to all elements $Z > 11$ with a detection limit of the order of 0.1 wt. % and a sampling depth of about one micron. Five samples were examined on the outer surfaces or on freshly exposed fracture surfaces using the NBS theoretical matrix procedures frame P for rough surfaces.¹³ Frame P is believed to have an error distribution within 20 percent relative.

Six pressure quenched samples (three each from the AI and EP material) were metallographically cross-sectioned and analyzed, corresponding to interior and near surface regions of the samples. Quantitative analysis of these samples was made using NBS frame C procedures.¹⁴ Frame C procedures

yield an error distribution such that 95 percent of all samples fall within five percent relative of the amount present on metallographically polished surfaces.

The metallographically mounted samples were further analyzed by an ion microprobe analysis (IMA). This analytical technique has very high sensitivity (typically one ppm) for all elements of the periodic table.

The result of these extensive analyses was that the magnetically active AI starting powder had substantial levels of Cl impurities in addition to the trace metallic impurities reported earlier.¹⁰ The quantitative analyses by EDS and IMA techniques revealed that the Cl levels in pressure treated and magnetically active AI materials were about 1.0 wt. % and that the Cl was distributed non-uniformly within the samples. The non-active materials, especially the EP material, showed no detectable Cl contamination within the combined sensitivities of the EDS and IMA techniques. This analysis showed that Cl levels, if present, were below 0.01 wt. % in the non-magnetic materials such as the EP materials.

Silicon (Si) was also detected in the pressure quenched samples from both AI and EP materials. The EDS technique indicated that Si was also distributed non-homogenously in the samples, with an average level of 0.15 wt. % in the AI materials and 0.05 wt. % in the EP materials. Since Si was not detected in the as received powders from these sources, we concluded that the Cl impurity contamination was critical in producing the magnetic anomalies. Si may have been introduced by either exposure to the pyrophyllite gaskets used in pressurizing the samples or from the silicone grease used to mount the samples for the magnetic measurements after pressurization before chemical analysis.

This conclusion was supported by the fact that samples containing Si introduced by either means did not show magnetic anomalies when the Cl content differed significantly from the AI material.

PREPARATION OF Cl DOPED CdS MATERIALS

In view of the above results, a variety of preparation techniques was used in an attempt to make suitably doped materials. Earlier Differential Scanning Calorimetry (DSC) results had suggested that the active AI material had been prepared by a precipitation technique.¹⁵

a. Mixtures of CdS and CdCl₂ Powders

Pure CdS powders (EP) were mixed with reagent grade CdCl₂ powders to yield nominal Cl contents of about 1.0, 1.5, and 2.0 wt. % the mixture. The thermal properties of these materials, both in the as prepared and in the as quenched condition were measured by the DSC technique described elsewhere.¹⁵ The only peaks observed were the dehydration peak at 100°C from the hydrated CdCl₂ powder and the eutectic melting peak at 535°C of the mixture suggesting that the NaCl high pressure phase was not retained after pressure quenching.

None of these materials exhibited anomalous magnetism after pressure quenching.

b. Precipitation Reaction

The standard procedure of producing CdS materials by precipitation from a hydrous CdCl₂ solution using H₂S gas was used. Small batches (~ 100 ml) of CdCl₂ solutions with starting normalities in the range of 0.1 to 1.0 N with respect to Cl were prepared. These solutions had the natural pH of solution.

Precipitation of CdS materials from these solutions at ambient temperatures occurred when the insoluble CdS precipitated as H₂S gas was slowly bubbled through the solution. The CdS precipitate contained between 0.5 and 4.11 wt. % Cl varying roughly with the normality of the starting solution. The nominal Cl and Sulphur (S) contents were determined by an ion chromatography method developed by NBS.¹⁶ Ultrasonically washing the precipitate in distilled water revealed that roughly half the Cl content was easily removed. The remaining Cl was probably incorporated in the CdS lattice.

Both pellets and pressure quenched samples made from these materials were studied by DSC, and their behavior was similar to the behavior of the Al material reported earlier.¹⁵

Some variability in Cl content within each precipitate aliquot occurred suggesting that critical chemical parameters, such as the decrease in molarity as the reaction proceeds, were affecting the Cl content of these batch produced materials.

An analysis of the various ionic species present in the aqueous solutions of CdCl₂ was made using equilibrium constants (K₁) in the following set of competing reactions:

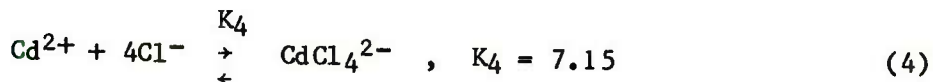
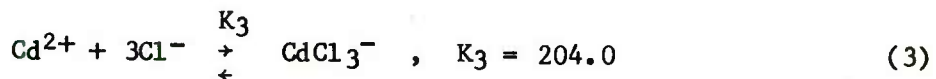
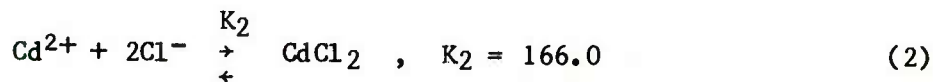
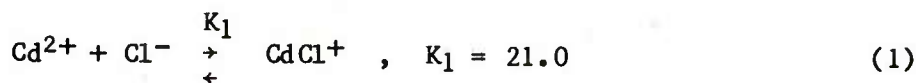

which can be expressed in the generalized form:

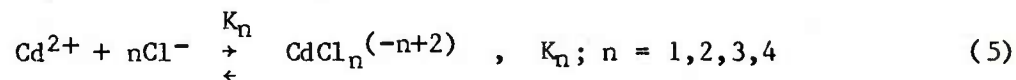

The fraction, α_n , of a particular equilibrium species present in solution can be given as:

$$\alpha_n = \frac{[\text{CdCl}_n]}{C} = K_n [\text{Cl}^-]^n \alpha_0 \quad (6)$$

where

$$\alpha_0 = \frac{[\text{Cd}^{+2}]}{C}$$

and

C = total concentration of cadmium containing species.

Given the initial Cd^{+2} and Cl^- concentration, the equations can be solved for α_n . The results for various CdCl_2 molarities are shown in Figure 1. The wide variation in the different ion species especially in the region of normality below 0.5N, where the magnetically active AI materials were produced is quite apparent. It is not clear which ion or combination of these ions produces the necessary complex in the precipitate to yield anomalous magnetism after pressure quenching.

A preliminary examination of the precipitated materials by transmission electron microscopy (TEM) and small angle x-ray scattering techniques showed the presence of small spherical crystallites (dia. $\sim 50\text{\AA}$) in the precipitated powders. These results are in good agreement with the results of Sato, Itoh, and Yamashita.¹⁷

Examination of these materials by DSC showed only the eutectic melting peak associated with a mixture of CdCl_2 and CdS , indicating that the initial complex compound decomposed to a simple mixture on heating. No dehydration peak was observed, which indicates that the as precipitated powders were not a simple mixture of CdS and CdCl_2 . These results were also obtained on the magnetically active AI starting powders.¹⁵ Pressure quenched samples of the precipitated powders containing $\text{Cl} > 0.7$ wt. % exhibited the exothermic peak associated with the transformation of the metastable of NaCl high pressure phase. Pressure quenched samples made from powders containing less than 0.7 wt. % Cl showed retained NaCl phase in addition to the wurtzite and zinc blende phases by both x-ray examination and optical evidence of small platelets.

The magnetic behavior of pressure quenched samples of these materials is shown in Figure 2 and will be discussed subsequently.

ACID DOPING TECHNIQUE

Samples of pure CdS were stirred and heated with various HCl and NaCl solutions to determine whether Cl^- could be incorporated directly into the CdS lattice.

This technique produced CdS materials containing Cl levels of about 0.1 wt. %. Again about 50 percent of the Cl content could be removed by ultrasonically washing the powders in distilled water. It was not possible to obtain Cl contents above 0.2 wt. % by this technique.

DSC analysis of the acid leached samples revealed no eutectic melting peak at 535°C in the precipitate powders and a broad weak exotherm centered

around 350°C in pressure quenched samples. This indicated retention of only a small quantity of the zinc blende phase, characteristic of very pure CdS.¹⁵ Metallographic examination of the samples revealed a small fraction of platelets after quenching, suggesting a retained NaCl phase in these samples which was below the sensitivity of the DSC technique.

The magnetic behavior of pressure quenched samples made from these materials is shown in Figure 2 and is discussed subsequently.

MAGNETIC MEASUREMENTS

The dc magnetization as a function of magnetic field was determined by either a vibrating sample magnetometer (VSM) or a SQUID magnetometer. The ac susceptibility was determined using the Hartshorn bridge described earlier.¹¹

The VSM measurements reported here were made in a variety of sample chamber configurations. The configuration shown in Figure 3 was used for more than half the samples tested. A modification of this basic design was used to measure the simultaneous changes in electrical conduction and magnetic moment of 17 samples reported elsewhere.^{8,9} In all sample configurations, the magnetic moment was measured using field sweeps below 100 Oe/min., and no systematic errors were observed.

The first nine samples measured in the VSM were mounted in a teflon sample holder which placed the samples in a random orientation with respect to field. This random orientation was fixed for each measurement, however. Sample CdS #51, which was measured in the teflon sample holder, was examined for field orientation effects. At high field, (> 1000 Oe), this sample exhibited large paramagnetism. By rotating the VSM vibrator about the axis of the sample rod, we observed a large but reproducible variation in magnetic

moment at constant field. A cursory examination of our sample geometry suggested that the maximum moment occurred when the field was oriented in the plane of the sample. All subsequent sample holders were designed to align the field with plane of the disc samples. Therefore, all subsequent samples were measured in this manner.

The SQUID magnetometer, shown schematically in Figure 4, allowed the magnitude and sign of the magnetic moment to be determined in fields up to 60 kOe at LHe temperatures.

Both the SQUID and VSM systems were periodically calibrated using Ni and $\text{CuSO}_4 \cdot 5\text{H}_2\text{O}$ as standards. The ac bridge was calibrated using the superconducting transition in a Pb sample.

The diamagnetic susceptibilities were determined from either the slope of the measured M vs. H curves from the VSM or by direct comparison with known standards in the SQUID and ac magnetometers.

For those samples exhibiting paramagnetism in the VSM, the generally small region of low field where the samples were diamagnetic was neglected and the susceptibility was determined by forcing the intercept of the slope to pass through the origin of the M vs. H plot. In a few cases where this analytic technique could lead to serious error in determining χ , i.e., when the diamagnetism persisted to above 100 Oe before becoming paramagnetic, the actual slope of the M vs. H was calculated. Six such samples were of the latter type, and are included in Table I with both their diamagnetic and paramagnetic susceptibilities. The remaining paramagnetic samples had diamagnetic regions of such small extent that it was not possible to determine their diamagnetic susceptibilities.

TABLE I. DIAMAGNETIC AND PARAMAGNETIC SUSCEPTIBILITIES OF PRESSURE QUENCHED CDS CONTAINING Cl

Material Source	Cl (wt. %)	Preparation	χ Mean	χ_{Dia} (Max)	χ_{Para} (Max)	No. Observations
Eagle Picher (EP)	0	n.a.	< 1.0E-5			3
Alpha Inorganic*	0	n.a.	< 1.0E-5			2
NBS 21A	.04	Acid Doped	< 1.0E-6			3
NBS 23	.10	Acid Doped	< 2.0E-6	-2.0E-6		1
NBS 21	.13	Acid Doped	< 1.0E-6			2
NBS 22	.14	Acid Doped	1.4E-6	-5.0E-6		10
NBS 26	.16	Acid Doped	5.3E-5	-1.6E-4		4
NBS 25	.20	Acid Doped	< 1.0E-6			1
NBS 28	.20	Acid Doped	1.0E-6	-1.0E-6		2
NBS 31B	.50	Precipitation	< 1.0E-6			1
NBS 5	.68	Precipitation	< 1.0E-5			1
NBS 8	.72	Precipitation	2.2E-4	-1.6E-3		14
Alpha Inorganic**	.72	n.a.	2.4E-3	-4.0E-2	+1.4E-3	51
NBS 1	.83	Precipitation	7.9E-4	-7.9E-3		11
NBS 2	.83	Precipitation	< 1.0E-5			2
NBS 17	.93	Precipitation	< 1.0E-6			1
NBS 31C	1.2	Precipitation	< 1.0E-6			1
NBS 12	2.8	Precipitation	< 1.0E-6			3
NBS 20 F.5-2	3.5	Precipitation	< 1.0E-6			1
NBS 11	3.9	Precipitation	< 1.0E-6			1

*Alpha Inorganic, Stock Number 20130, Lot Number 062778

**Alpha Inorganic, Stock Number 20130, Lot Number 033072

The average absolute volume susceptibilities of pressure quenched samples from each sample lot were determined and tabulated in Table I together with source identification, Cl content, preparation technique, the maximum diamagnetic and paramagnetic susceptibilities observed, and the number of observed points.

Not included in this tabulation are the results for an additional 20 samples, which were either starting pellet samples, or samples which had been slowly depressurized ($< 10^3$ bars/sec) from above the NaCl transition pressure or samples which had been rapidly quenched from below this transition. These samples were made from various Cl containing materials described above and none exhibited any detectable anomalous susceptibility in the SQUID or VSM systems.

Only pressure quenched samples from the AI source containing 0.72 wt. % Cl exhibited both diamagnetism and paramagnetism. The IMA showed that the paramagnetic and ferromagnetic impurity elements in this material were below 20 ppm by weight and could not account for the large paramagnetic susceptibilities observed here. In addition, the detailed behavior of the paramagnetism observed^{7,10} precluded the possibility of sample contamination as being the cause of this anomalous behavior. Of the 51 measurements made on this material, we observed anomalous paramagnetism 16 times.

The mean value of $|\chi_v|$ for each sample material lot is plotted as a function of Cl content in Figure 2. The curve shown is a reasonable fit to these values neglecting the single point at 0.16 wt. % Cl whose value was 5.3×10^{-5} cgs units. The data shown in Figure 2 was obtained from 115

observations on 109 different samples. The nominal Cl content is the average Cl determined from several analyses of each sample material lot. The Cl uncertainty was approximately 10 percent relative in the acid doped material and approximately 20 percent relative in the precipitated material.

The mean diamagnetic susceptibility of all observations on sample materials, excluding the magnetically active NBS 1, NBS 8, and AI lot 033072 materials, was calculated. A mean diamagnetic volume susceptibility of the order of 1×10^{-5} cgs units was determined using 39 data points which is in good agreement with the volume susceptibility calculated from handbook values of the diamagnetic susceptibility and the mass (~ 15 mg) of the samples.

PLATELET VOLUME MEASUREMENTS

Quantitative metallography often serves as a sensitive guide to the physical processes that material specimens have undergone. It is an especially useful adjunct technique in studying the morphology of samples of different chemical compositions which may have a profound effect on the physical behavior observed.

Fast and slow quenched EP samples appeared to be nearly 100 percent wurtzite phase after quenching. The small amount of zinc blende phase reported earlier in the x-ray and DSC analysis¹⁵ could not be distinguished by this technique. In both cases, the crystallites were pancake shaped, with the axis of rotational symmetry along the load axis. The diameter of the crystallites after fast quenching was about 70μ and the thickness was about 20μ . After slow quenching, these values became 120μ and 30μ , respectively. It is important to note that over four orders of magnitude change in the

depressurization rate produced little effect on the grain size observed.

In the AI samples, both the retained NaCl phase (platelets) and wurtzite (and zinc blende) matrix phase grain size appeared bimodal, and had similar distributions. Both phases were composed of a mixture of equiaxed crystallites 10-50 μ in diameter and platelets 100-300 μ in diameter and 15-30 μ in thickness oriented roughly perpendicular to the load axis. Fast quenched and slow quenched samples were very similar in appearance.

The above results suggested an influence of the specimen composition on the post-quench morphology. Microstructural investigation over a wide variation of Cl contents confirmed this suspicion. The volume fraction of NaCl phase (platelet) retained and the microstructural features observed seemed to vary continuously with the Cl level of the starting material as shown in Figure 5.

The internal structure of the NaCl phase (platelets) was studied using optical microscopy and scanning electron microscope (SEM) techniques. No discernable microstructure was observed in the platelets to within the resolution of these techniques. The platelets showed little optical rotation in polarized light and were harder than the polycrystalline matrix material. Transverse cracks were generally observed in the platelets which often terminated at the interface between the platelets and matrix material. The latter effect is interpreted as evidence of the brittle nature of the platelets and results from the large volume change which occurs in the NaCl to wurtzite transition on depressurizing.

Although crystal structure determination of the platelets was not made directly on those samples having less than 20 percent volume fraction of platelets, it can be deduced that the platelets are of the retained NaCl high pressure crystal structure. This deduction is based on the following facts. (1) The platelets of NaCl structure observed in samples highly doped with Cl, where the platelet volume fraction was greater than 90 percent, were similar in character to the platelets observed in the lower Cl content material; and (2) the qualitative estimate of the amount of quenched-in NaCl phase determined from both the DSC and x-ray measurements was in good agreement with the volume fraction of platelets determined in similar samples. Both sets of measurements correlated with the nominal Cl content.

DISCUSSION OF EXPERIMENTAL RESULTS

Several interesting results are apparent from an examination of these data.

(1) The largest diamagnetism exceeded the largest paramagnetism observed by about an order of magnitude for the Al material containing 0.72 wt. % Cl.

(2) A large scatter of susceptibilities was observed for CdS materials having $0.7 < \text{Cl} < 0.83$ wt. %. If one conservatively defines anomalous magnetic behavior when $\chi_{\text{sample}} > 10\chi_{\text{literature}}$, then the reproducibility of obtaining anomalous behavior was about 57 percent for this group. A somewhat lower "success" rate was obtained in sample material prepared by techniques described in this report (about 35 percent) than in the as received Al material.

(3) Another rather subtle result is that, with the exception of a single sample of CdS containing 0.16 wt. % Cl, which was prepared by the acid doping technique, all magnetically active samples were prepared by precipitation from an aqueous bath and had a nominal Cl content between 0.7 and 0.83 wt. %. (The role of Si in conjunction with Cl, if any, is not known at present.)

(4) We have not observed lossless electrical conduction in any of our samples.

DISCUSSION

These results show that the conditions under which the anomalous electrical and magnetic behavior may occur are the rapid pressure quenching ($< 10^5$ bars/sec.) from above the wurtzite to NaCl phase transition pressure in CdS samples doped with Cl to levels in the range of 0.75 ± 0.1 wt. %.

The results also show that there is considerable scatter in the measured susceptibilities in this range. The many possible parameters that could generate this scatter are either uncontrollable or uncontrolled under present experimental conditions. The former category includes the possibility of critical ranges in the minor constituents of our material (~ 10 ppm) and quenching defects. The latter category includes the ambient conditions of the material preparation process, chemical variability of the Cl impurity in samples prepared from the same lot, elapsed time between the pressure treatment and magnetic measurement, sample surface contamination with Si from the pyrophyllite gaskets, (although the results of Nam et al² would seem to obviate this possibility), etc.

The metastability of the measured susceptibilities^{10,11} and their variability described above suggest that this anomalous behavior may be caused by some critical structural or chemical phenomenon.

To examine the nature of such a critical phenomenon, let us speculate on the interrelationship of the quenching process and sample chemistry. The quenched-in platelets (presumably the retained NaCl phase) appear featureless under SEM examination to a resolution of about 10^4 Å. These platelets are neither necessary nor sufficient for the anomalous behavior, since they exist in samples which have never shown the anomalous behavior and remain in samples in which such behavior has decayed to below the detection limits of the magnetometers. Also, we can accomplish nearly complete recovery of the NaCl phase in samples containing Cl content larger than 2.8 wt. % without pressure quenching. None of the latter samples, together with fast quenched samples from the same group, ever showed detectable anomalous magnetic behavior.

We consider, therefore, a metastable decomposition of the high pressure NaCl phase. This decomposition is strongly dependent on quenching statistics within a narrow range of sample chemistry. The metastability, as determined from electrical and magnetic measurements, has been shown to depend on annealing conditions.¹¹ We are unable to determine any structural change in the character of the platelets (NaCl phase) to the limit of the resolution of the SEM; thus such a decomposition may involve the motion of a mobile specie, e.g., Cl in interstitial sites.

Gibbs¹⁸ separated into two categories the infinitesimal changes to which a metastable phase (eg. NaCl phase) must be resistant. One is a change that is infinitesimal in degree but large in extent, as exemplified by a small

compositional fluctuation spread over a large volume. Cahn¹⁹ has shown that the early stages of such a decomposition (spinodal decomposition) in a solid proceed in a continuous and coherent manner, such that detection is usually by observing at the resultant periodic elastic strain effects on physical properties. To experimentally study such a process would require techniques sensitive to unusual electronic distribution and behavior. We recognize that the anomalous effects reported here must ultimately be related to such electronic behavior, whatever the underlying physical structure.

Of course, other models for such phenomena exist.²⁻⁶ Only further experimental tests will determine which, if any, of these models apply or if a new collective phenomenon is occurring in these samples.

CONCLUSION

The anomalous electrical and magnetic properties occur in CdS samples which have been heavily doped with Cl to levels of 0.75 ± 0.1 wt. % after pressure quenching from above the high pressure phase transition at rates in excess of 10^5 bars/sec.

The material which may exhibit these anomalous phenomena can be prepared by precipitation from a Cl containing bath, if the resultant Cl concentration is within the range above.

The active material is not a simple mixture of CdS and CdCl₂, but rather a material containing CdS_xCl_{1-x} complex(es). The particular complex(es) have not been identified nor has the structure of the complex(es) been determined in the anomalous samples at present.

REFERENCES

1. E. Brown, C. G. Homan, and R. K. MacCrone, *Phys. Rev. Lett.* 45, 478 (1980).
2. S. B. Nam, *Physica* 147B, 715 (1981); D. C. Reynolds, Y. Chung, and S. B. Nam, AFWAL-TR-82-1031, available through NTIS Accession No. AD-A120 156/5.
3. N. B. Brandt, S. V. Kuvshinnikov, A. P. Rusakov, and M. Semyonov, *JETP Lett.* 27, 37 (1978); C. W. Chu, A. P. Rusakov, S. Early, T. H. Geballe, and C. Y. Huang, *Phys. Rev.* B18, 2116 (1978).
4. T. H. Geballe and C. W. Chu, *Comm. Solid State Phys.* 9, 115 (1979); V. L. Ginzburg, *Sol. St. Comm.* 38, 991 (1981).
5. S. B. Nam and D. W. Allender, private communication.
6. M. Seel, T. C. Collins, J. J. Labik, M. Chandrasekhar, and H. R. Chandrasekhar, *Phys. Rev.* B27, 140 (1983).
7. R. K. MacCrone and C. G. Homan, *Sol. St. Comm.* 35, 615 (1980); C. G. Homan and R. K. MacCrone, *J. Non-Crystalline Solids* 40, 369 (1980).
8. C. G. Homan, K. Laojindanpun, and R. K. MacCrone, *Physica* 107B, 9 (1981).
9. C. G. Homan, K. Laojindanpun, and R. K. MacCrone, *Sol. St. Comm.* 45, 733 (1983).
10. C. G. Homan, D. P. Kendall, and R. K. MacCrone, *Sol. St. Comm.* 32, 521 (1979).
11. C. G. Homan and D. P. Kendall, Army Tech. Report ARLCB-TR-79004, available through NTIS, Springfield, VA, AD No. A069-609.
12. G. A. Samara and H. G. Drickamer, *J. Phys. Chem. Solids* 23, 457 (1962).
13. J. A. Small, D. E. Newbury, and R. L. Mylebust, "Analysis of Particles and Rough Samples by Frame P, a ZAF Method Incorporating Peak-to-Background Measurements," *Microbeam Analysis*, D. E. Newbury, Ed. (San Francisco Press, 1979), p. 243.

14. R. L. Mylebust, C. E. Fiori, and K. F. J. Heinrich, "A Compact Procedure for Quantitative Energy Dispersive Electron Probe X-Ray Analysis," NBS Tech. Note 1106, Frame C, September 1979.
15. P. J. Cote, G. P. Capsimalis, and C. G. Homan, Appl. Phys. Lett. 38, 927 (1981).
16. W. Koch, Analy. Chem. 54, 340 (1982).
17. R. Sato, H. Itoh, and Yamashita, Japan. Jour. of Appl. Phys. 3, 626 (1964).
18. J. W. Gibbs, "Collected Works," pp. 105-112, 252-258, Yale University Press, New Haven (1948).
19. J. W. Cahn, Trans. AIME 242, 166 (1968).

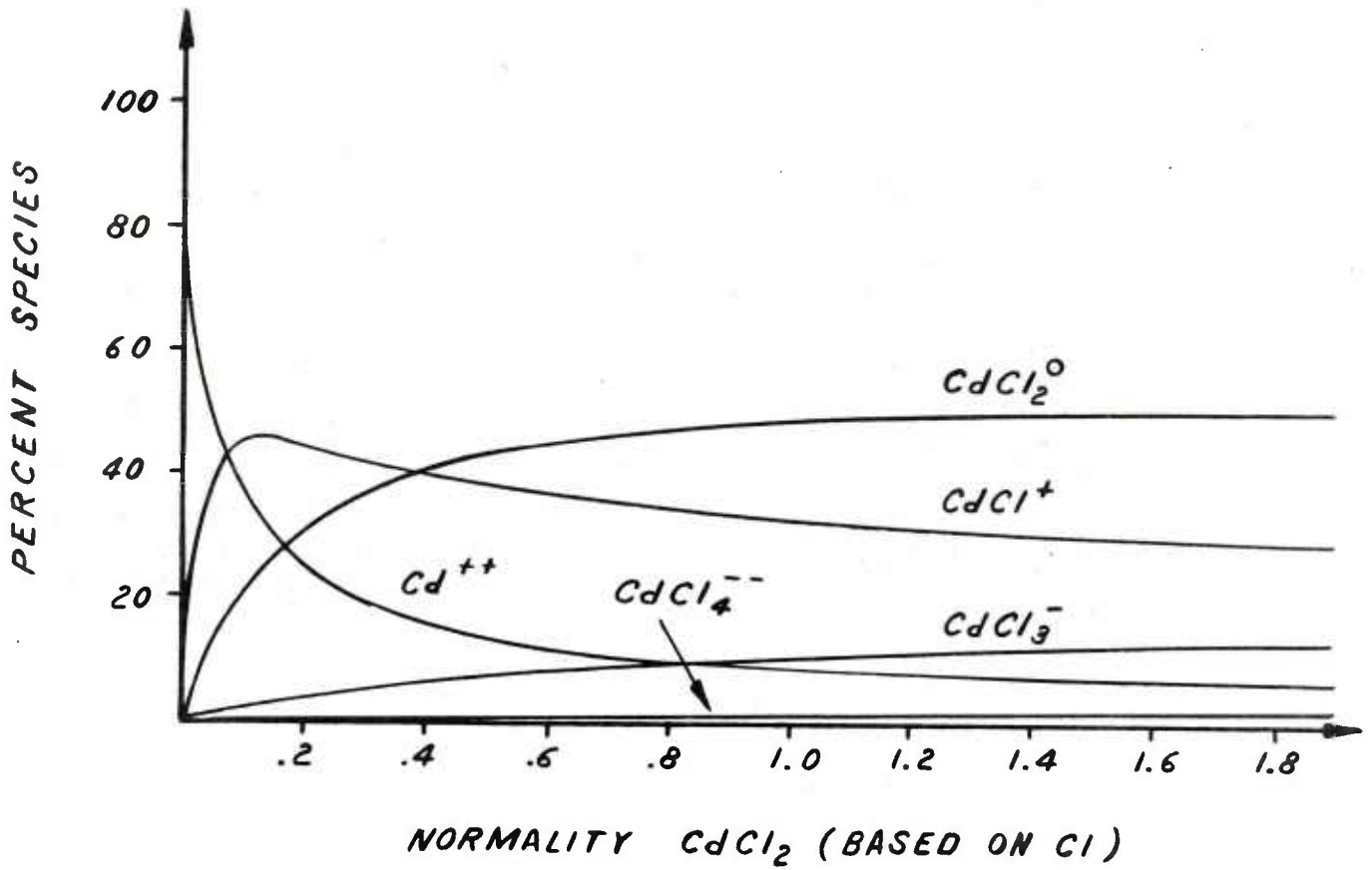

Figure 1. Variation of ionic species present in aqueous solution of CdCl₂ as a function of the molarity of solution based on [Cl⁻] chloride ion concentration in moles/liters.

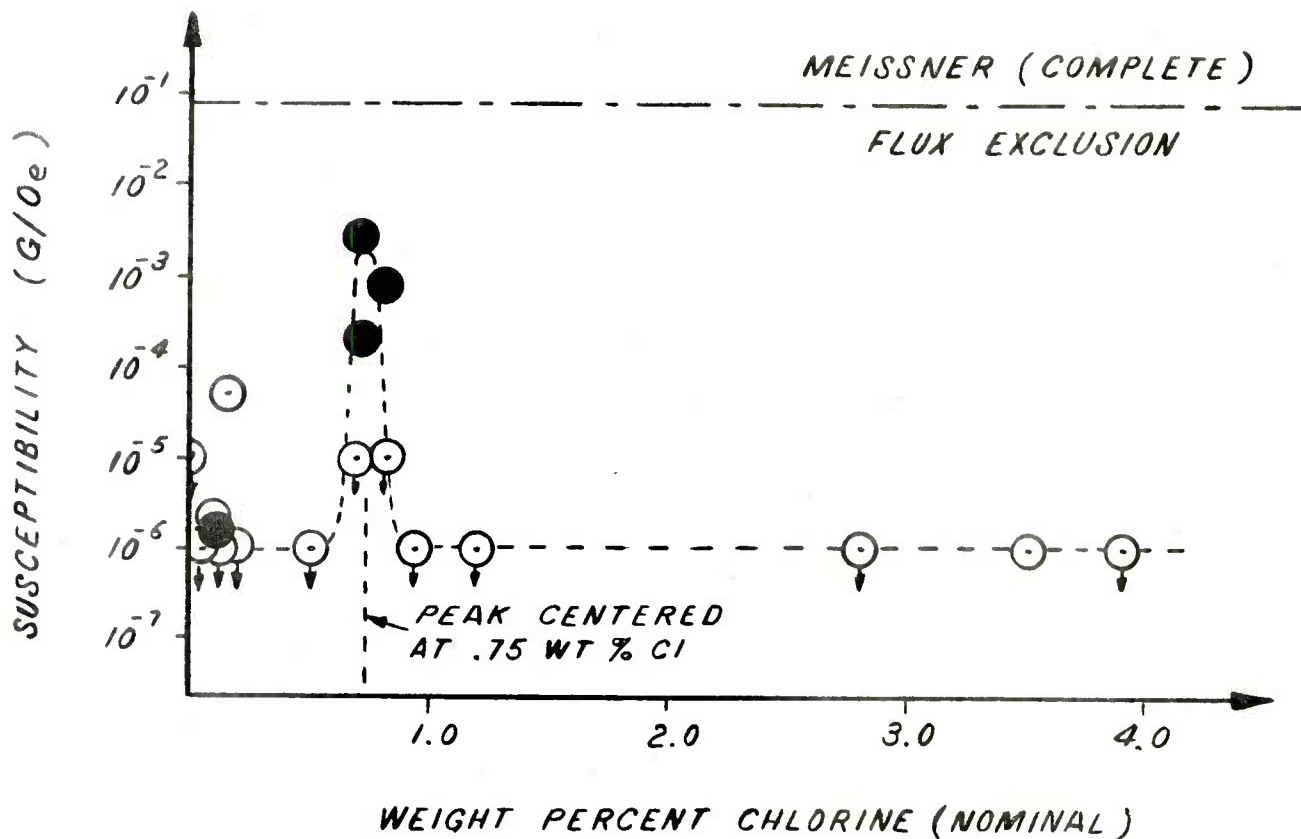
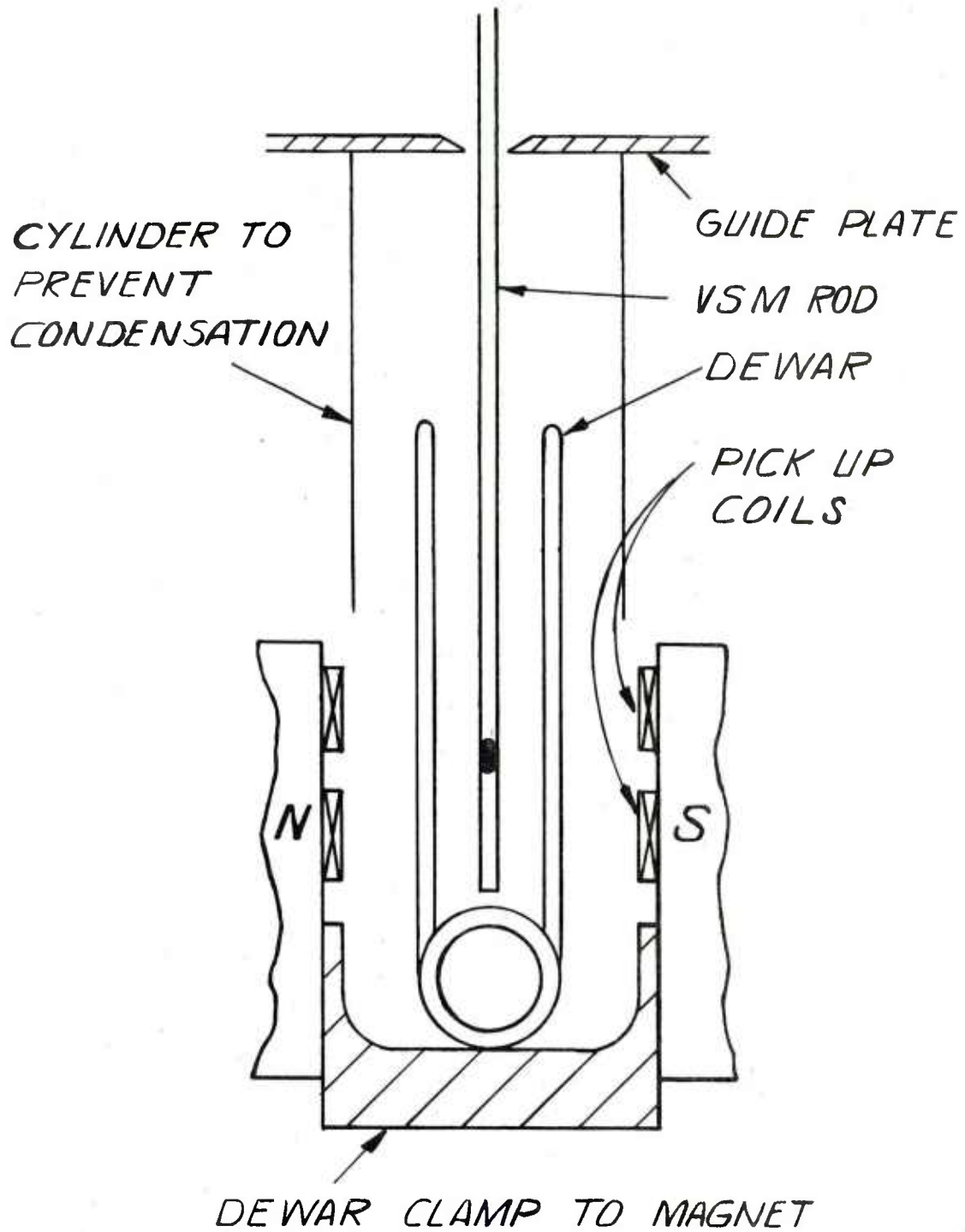

Figure 2. Mean value of the absolute magnetic volume susceptibility from each sample lot is plotted as a function of the nominal Cl content of the lot. Solid symbols represent the mean value determined from 10 or more observations on a particular sample lot as tabulated in Table I. Of the 115 observations represented in this figure, all but nine measurements which were measured at LHe temperatures in either the SQUID or ac magnetometers, were measured at LN₂ temperatures.



FRONT VIEW

Figure 3. Schematic of the sample chamber of the vibrating sample magnetometer, VSM. A Helitran cryogenic cooling system was used to provide the LN₂ measurement temperatures.

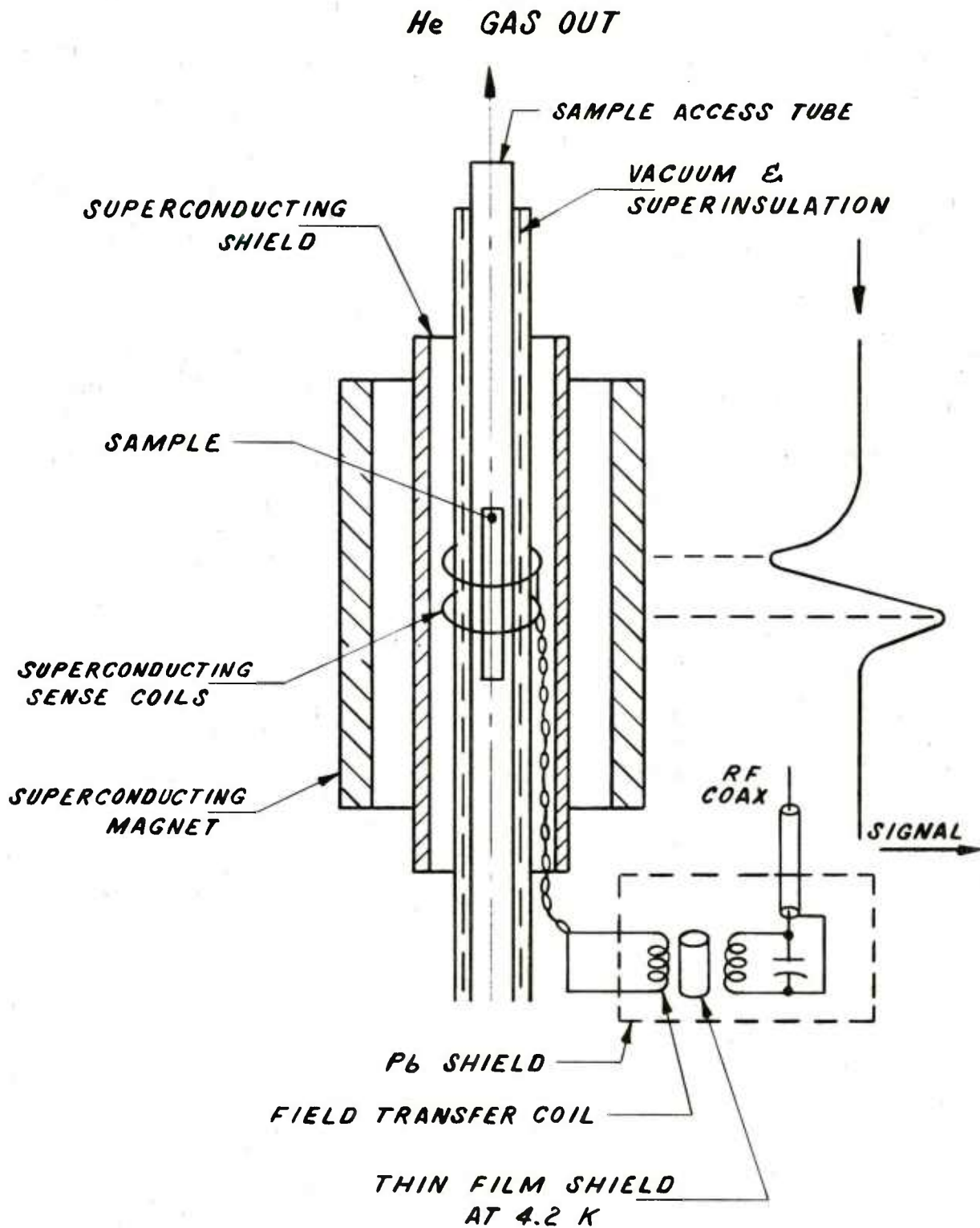

Figure 4. Schematic of SQUID magnetometer used at LHe temperatures. A typical signal generated as the sample is drawn through the sense coils is shown at right.

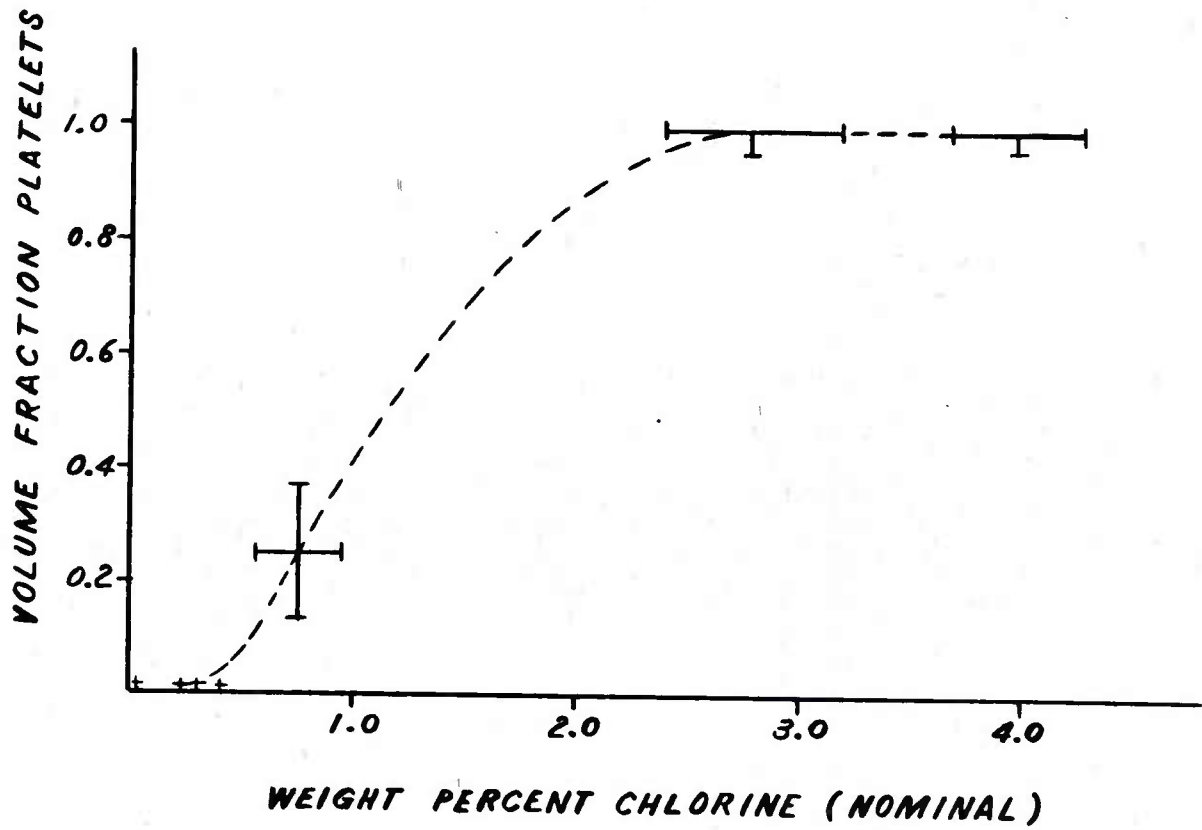

Figure 5. Volume fraction of NaCl phase (platelets) retained after pressure quenching is plotted as a function of the nominal Cl content.

READER EVALUATION

Please take a few minutes to complete the questionnaire below and return to us at the following address: Commander, Armament Research and Development Center, U.S. Army AMCCOM, ATTN: Technical Publications, DRSMC-LCB-TL, Watervliet, NY 12189.

1. Benet Weapons Lab. Report Number _____

2. Please evaluate this publication (check off one or more as applicable).

	Yes	No
Information Relevant	_____	_____
Information Technically Satisfactory	_____	_____
Format Easy to Use	_____	_____
Overall, Useful to My Work	_____	_____
Other Comments	_____	

3. Has the report helped you in your own areas of interest? (i.e. preventing duplication of effort in the same or related fields, savings of time, or money). _____

4. How is the report being used? (Source of ideas for new or improved designs. Latest information on current state of the art, etc.). _____

5. How do you think this type of report could be changed or revised to improve readability, usability? _____

6. Would you like to communicate directly with the author of the report regarding subject matter or topics not covered in the report? If so please fill in the following information.

Name: _____

Telephone Number: _____

Organization Address: _____

TECHNICAL REPORT INTERNAL DISTRIBUTION LIST

	<u>NO. OF COPIES</u>
CHIEF, DEVELOPMENT ENGINEERING BRANCH	
ATTN: DRSMC-LCB-D	1
-DP	1
-DR	1
-DS (SYSTEMS)	1
-DS (ICAS GROUP)	1
-DC	1
CHIEF, ENGINEERING SUPPORT BRANCH	
ATTN: DRSMC-LCB-S	1
-SE	1
CHIEF, RESEARCH BRANCH	
ATTN: DRSMC-LCB-R	2
-R (ELLEN FOGARTY)	1
-RA	1
-RM	1
-RP	1
-RT	1
TECHNICAL LIBRARY	5
ATTN: DRSMC-LCB-TL	
TECHNICAL PUBLICATIONS & EDITING UNIT	2
ATTN: DRSMC-LCB-TL	
DIRECTOR, OPERATIONS DIRECTORATE	1
DIRECTOR, PROCUREMENT DIRECTORATE	1
DIRECTOR, PRODUCT ASSURANCE DIRECTORATE	1

NOTE: PLEASE NOTIFY DIRECTOR, BENET WEAPONS LABORATORY, ATTN: DRSMC-LCB-TL,
OF ANY ADDRESS CHANGES.

TECHNICAL REPORT EXTERNAL DISTRIBUTION LIST

	<u>NO. OF COPIES</u>		<u>NO. OF COPIES</u>
ASST SEC OF THE ARMY RESEARCH & DEVELOPMENT ATTN: DEP FOR SCI & TECH THE PENTAGON WASHINGTON, D.C. 20315	1	COMMANDER US ARMY AMCCOM ATTN: DRSMC-LEP-L(R) ROCK ISLAND, IL 61299	1
COMMANDER DEFENSE TECHNICAL INFO CENTER ATTN: DTIC-DDA CAMERON STATION ALEXANDRIA, VA 22314	12	COMMANDER ROCK ISLAND ARSENAL ATTN: SMCRI-ENM (MAT SCI DIV) ROCK ISLAND, IL 61299	1
COMMANDER US ARMY MAT DEV & READ COMD ATTN: DRCDE-SG 5001 EISENHOWER AVE ALEXANDRIA, VA 22333	1	DIRECTOR US ARMY INDUSTRIAL BASE ENG ACTV ATTN: DRXIB-M ROCK ISLAND, IL 61299	1
COMMANDER ARMAMENT RES & DEV CTR US ARMY AMCCOM ATTN: DRSMC-LC(D) DRSMC-LCE(D) DRSMC-LCM(D) (BLDG 321) DRSMC-LCS(D) DRSMC-LCU(D) DRSMC-LCW(D) DRSMC-SCM-O (PLASTICS TECH EVAL CTR, BLDG. 351N) DRSMC-TSS(D) (STINFO) DOVER, NJ 07801	1 1 1 1 1 1 1 2	COMMANDER US ARMY TANK-AUTMV R&D COMD ATTN: TECH LIB - DRSTA-TSL WARREN, MI 48090	1
DIRECTOR BALLISTICS RESEARCH LABORATORY ARMAMENT RESEARCH & DEV CTR US ARMY AMCCOM ATTN: DRSMC-TSB-S (STINFO) ABERDEEN PROVING GROUND, MD 21005	1	COMMANDER US ARMY TANK-AUTMV COMD ATTN: DRSTA-RC WARREN, MI 48090	1
MATERIEL SYSTEMS ANALYSIS ACTV ATTN: DRSXY-MP ABERDEEN PROVING GROUND, MD 21005	1	COMMANDER US MILITARY ACADEMY ATTN: CHMN, MECH ENGR DEPT WEST POINT, NY 10996	1
		US ARMY MISSILE COMD REDSTONE SCIENTIFIC INFO CTR ATTN: DOCUMENTS SECT, BLDG. 4484 REDSTONE ARSENAL, AL 35898	2
		COMMANDER US ARMY FGN SCIENCE & TECH CTR ATTN: DRXST-SD 220 7TH STREET, N.E. CHARLOTTESVILLE, VA 22901	1

NOTE: PLEASE NOTIFY COMMANDER, ARMAMENT RESEARCH AND DEVELOPMENT CENTER,
US ARMY AMCCOM, ATTN: BENET WEAPONS LABORATORY, DRSMC-LCB-TL,
WATERVLIET, NY 12189, OF ANY ADDRESS CHANGES.

TECHNICAL REPORT EXTERNAL DISTRIBUTION LIST (CONT'D)

	<u>NO. OF COPIES</u>		<u>NO. OF COPIES</u>
COMMANDER US ARMY MATERIALS & MECHANICS RESEARCH CENTER ATTN: TECH LIB - DRXMR-PL WATERTOWN, MA 01272	2	DIRECTOR US NAVAL RESEARCH LAB ATTN: DIR, MECH DIV CODE 26-27, (DOC LIB) WASHINGTON, D.C. 20375	1 1
COMMANDER US ARMY RESEARCH OFFICE ATTN: CHIEF, IPO P.O. BOX 12211 RESEARCH TRIANGLE PARK, NC 27709	1	COMMANDER AIR FORCE ARMAMENT LABORATORY ATTN: AFATL/DLJ AFATL/DLJG EGLIN AFB, FL 32542	1 1
COMMANDER US ARMY HARRY DIAMOND LAB ATTN: TECH LIB 2800 POWDER MILL ROAD ADELPHIA, MD 20783	1	METALS & CERAMICS INFO CTR BATTELLE COLUMBUS LAB 505 KING AVENUE COLUMBUS, OH 43201	1
COMMANDER NAVAL SURFACE WEAPONS CTR ATTN: TECHNICAL LIBRARY CODE X212 DAHLGREN, VA 22448	1		

NOTE: PLEASE NOTIFY COMMANDER, ARMAMENT RESEARCH AND DEVELOPMENT CENTER,
 US ARMY AMCCOM, ATTN: BENET WEAPONS LABORATORY, DRSMC-LCB-TL,
 WATERVLIET, NY 12189, OF ANY ADDRESS CHANGES.