

AD-A137 731

RADIATION SURVEY FOR INSTALLATION OF THE COBALT-60
THERATRON-80 AT ARMED. (U) ARMED FORCES RADIOBIOLOGY
RESEARCH INST BETHESDA MD K P FERLIC DEC 83

1/1

UNCLASSIFIED

AFRR1-TR-83-4

F/G 6/18

NL

AFRR1

END

FORMED

3-

ETC

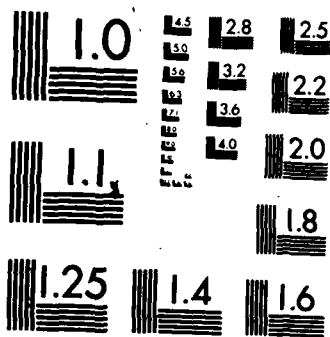

MICROCOPY RESOLUTION TEST CHART
NATIONAL BUREAU OF STANDARDS-1963-A

12

AFRRI TECHNICAL REPORT

Radiation survey for installation of the cobalt-60 Theratron-80 at Armed Forces Radiobiology Research Institute

K. P. Ferlic

DTIC

FEB 10 '84

DEFENSE NUCLEAR AGENCY
ARMED FORCES RADIOBIOLOGY RESEARCH INSTITUTE
BETHESDA, MARYLAND 20814

APPROVED FOR PUBLIC RELEASE; DISTRIBUTION UNLIMITED

84 02 10 025

AD A 137731

AFRRI TR83-4

DTIC FILE COPY

REVIEWED AND APPROVED

Naresh K. Chawla
NARESH K. CHAWLA, Ph.D.
Head, Radiation Safety
Department

L. S. Myers, Jr.
LAWRENCE S. MYERS, Ph.D.
Scientific Director

Bobby R. Adcock
BOBBY R. ADCOCK
COL, MS, USA
Director

UNCLASSIFIED

SECURITY CLASSIFICATION OF THIS PAGE (When Data Entered)

REPORT DOCUMENTATION PAGE		READ INSTRUCTIONS BEFORE COMPLETING FORM
1. REPORT NUMBER AFRRI TR 83-4	2. GOVT ACCESSION NO. AD-A137 731	3. RECIPIENT'S CATALOG NUMBER
4. TITLE (and Subtitle) RADIATION SURVEY FOR INSTALLATION OF THE COBALT-60 THERATRON-80 AT ARMED FORCES RADIOBIOLOGY RESEARCH INSTITUTE	5. TYPE OF REPORT & PERIOD COVERED	
	6. PERFORMING ORG. REPORT NUMBER	
7. AUTHOR(s) K. P. Ferlic	8. CONTRACT OR GRANT NUMBER(s)	
9. PERFORMING ORGANIZATION NAME AND ADDRESS Armed Forces Radiobiology Research Institute (AFRRI) Defense Nuclear Agency Bethesda, Maryland 20814	10. PROGRAM ELEMENT, PROJECT, TASK AREA & WORK UNIT NUMBERS NWED QAXM MJ 97810	
11. CONTROLLING OFFICE NAME AND ADDRESS Director Defense Nuclear Agency (DNA) Washington, DC 20305	12. REPORT DATE December 1983	
	13. NUMBER OF PAGES 48	
14. MONITORING AGENCY NAME & ADDRESS (if different from Controlling Office)	15. SECURITY CLASS. (of this report) UNCLASSIFIED	
	15a. DECLASSIFICATION DOWNGRADING SCHEDULE	
16. DISTRIBUTION STATEMENT (of this Report) Approved for public release; distribution unlimited.		
17. DISTRIBUTION STATEMENT (of the abstract entered in Block 20, if different from Report)		
18. SUPPLEMENTARY NOTES		
19. KEY WORDS (Continue on reverse side if necessary and identify by block number)		
20. ABSTRACT (Continue on reverse side if necessary and identify by block number) This report documents the initial radiation survey for installation of the cobalt-60 teletherapy unit in the Standards Lab of the Armed Forces Radiobiology Research Institute. Room modifications, alarms, and interlocks for this installation are described. Exposure levels as observed for the approved irradiation configurations are provided. Estimated personnel exposures and additional shielding recommendations pro-rated to the maximum authorized source load are made.		

DD FORM 1473
1 JAN 73

EDITION OF 1 NOV 65 IS OBSOLETE

UNCLASSIFIED

SECURITY CLASSIFICATION OF THIS PAGE (When Data Entered)

CONTENTS

	<u>Page</u>
Introduction	3
Location and Description of Room	3
Description of Source	9
Facility Interlocks and Alarms	12
Modes of Operation	15
Survey	15
Summary Evaluation	36
Appendix A. Calculations for Shielding of Prep Area and Rooms 2154 and 2155	41
Appendix B. Recommendation for Theratron Based on Survey of Shielding	45



Accession For	
NTIS GRA&I	<input checked="" type="checkbox"/>
DTIC TAB	<input type="checkbox"/>
Unannounced	<input type="checkbox"/>
Justification	
Distribution/	
Availability Codes	
Avail and/or	
Dist	Special
A1	

INTRODUCTION

The Standards Lab of the Armed Forces Radiobiology Research Institute (AFRRI) was originally designed for the storage of radioactive standards and a large X-ray unit (approximately 250 Kvp). With the acquisition of a surplus therapeutic cobalt source (Theratron-80) from the Walter Reed Army Medical Center and its placement in the AFRRI Standards Lab, it was necessary to reevaluate the shielding provided by the walls of this room for the increased photon energy of cobalt-60 and, more importantly, the increased intensity. This report describes the room modifications, the survey data, and the installed alarms and interlocks. Estimated personnel exposures and additional shielding recommendations are based on the survey data, pro-rated for the maximum source load permitted by the license granted by the Nuclear Regulatory Commission.

This report reflects AFRRI as it existed in April 1980; Phase V and subsequent renovations are not included. This is being published for documentation purposes for the survey performed at the time of installation of the Theratron-80.

LOCATION AND DESCRIPTION OF ROOM

The Theratron is located in the former Standards Lab of AFRRI. AFRRI consists of Buildings 42, 43, 44, 45, and 46 on the grounds of the National Naval Medical Center (Figure 1). AFRRI is made up of five levels, the first four of which are partially or completely above ground (Figure 2). The Standards Lab is a sub-basement room, and extends approximately 7.5 ft/2.29 m below the floor of the first level. The sub-basement area is 17 ft/5.18 m high, 17 ft/5.18 m wide, and 44.6 ft/13.6 m long. The steel-reinforced concrete walls are of the following thicknesses: the north wall, west wall, and east wall are each 2 ft/0.61 m thick; the south wall is 1 ft/0.30 m thick below a height of 11 ft/3.35 m, and 2 ft/0.61 m thick above 11 ft/3.35 m. The ceiling is concrete reinforced with 2 ft/0.61 m of steel (Figure 3).

The Standards Lab has two entrances. A shielded door opens from the sub-basement stairwell into the Control Room, and a steel freight door enters from the first floor 7.5 ft/2.29 m above the Standards Lab floor (sub-basement floor).

**NATIONAL NAVAL MEDICAL CENTER
BETHESDA, MARYLAND**

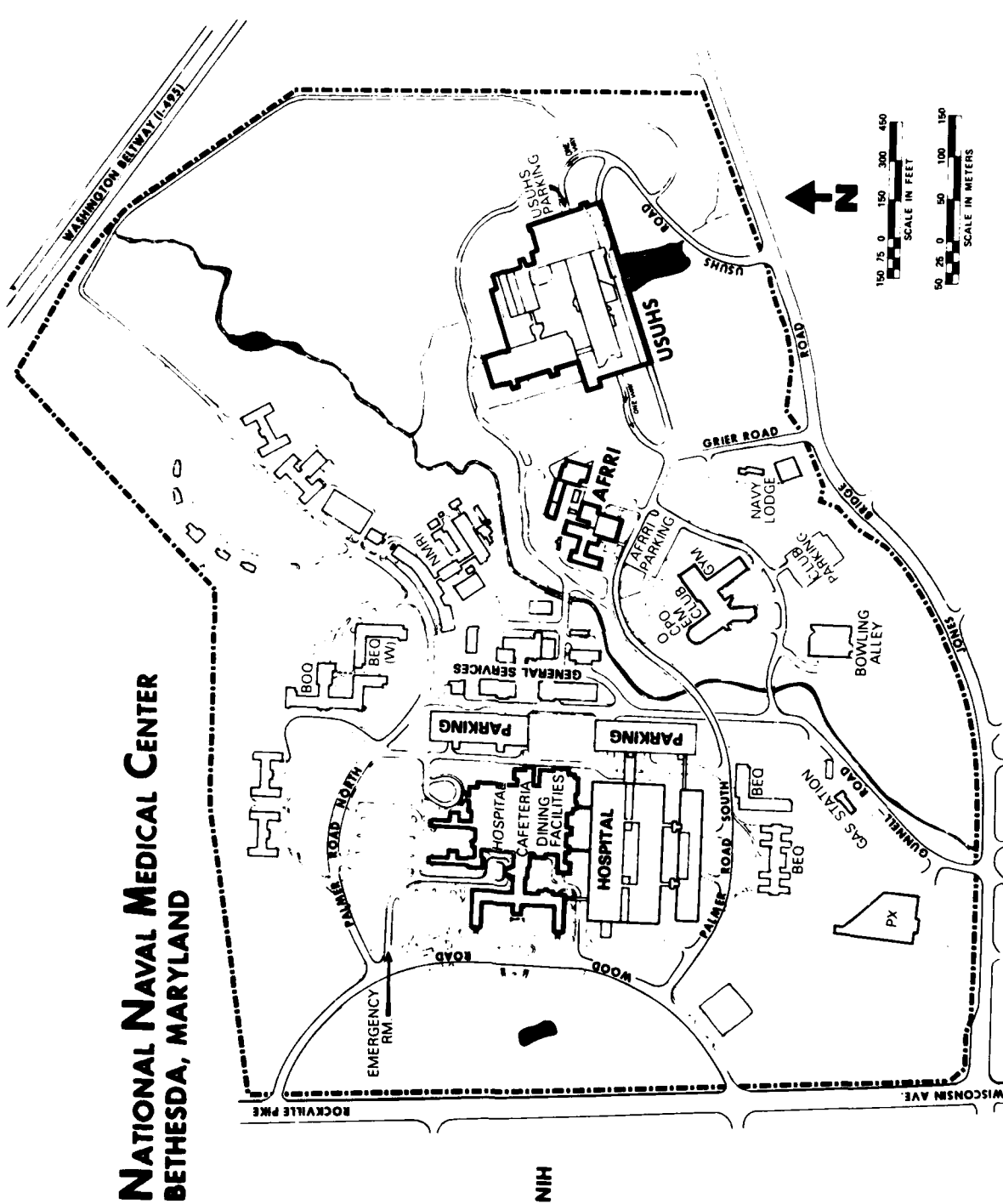

Figure 1. Location of AFRRRI relative to other NNMCM structures

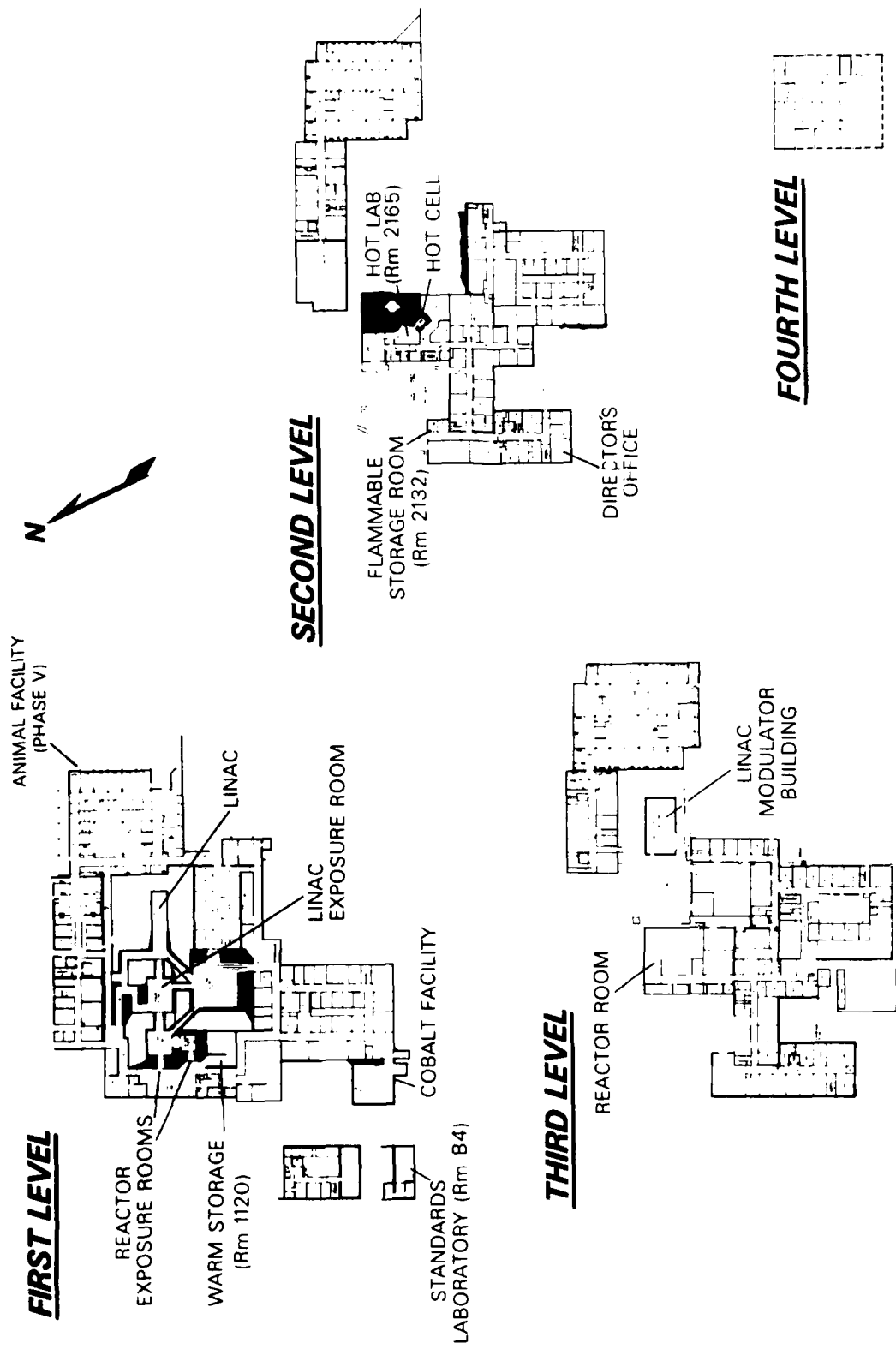

Figure 2. Floor plan of Standards Lab in relation to other AFRRI facilities

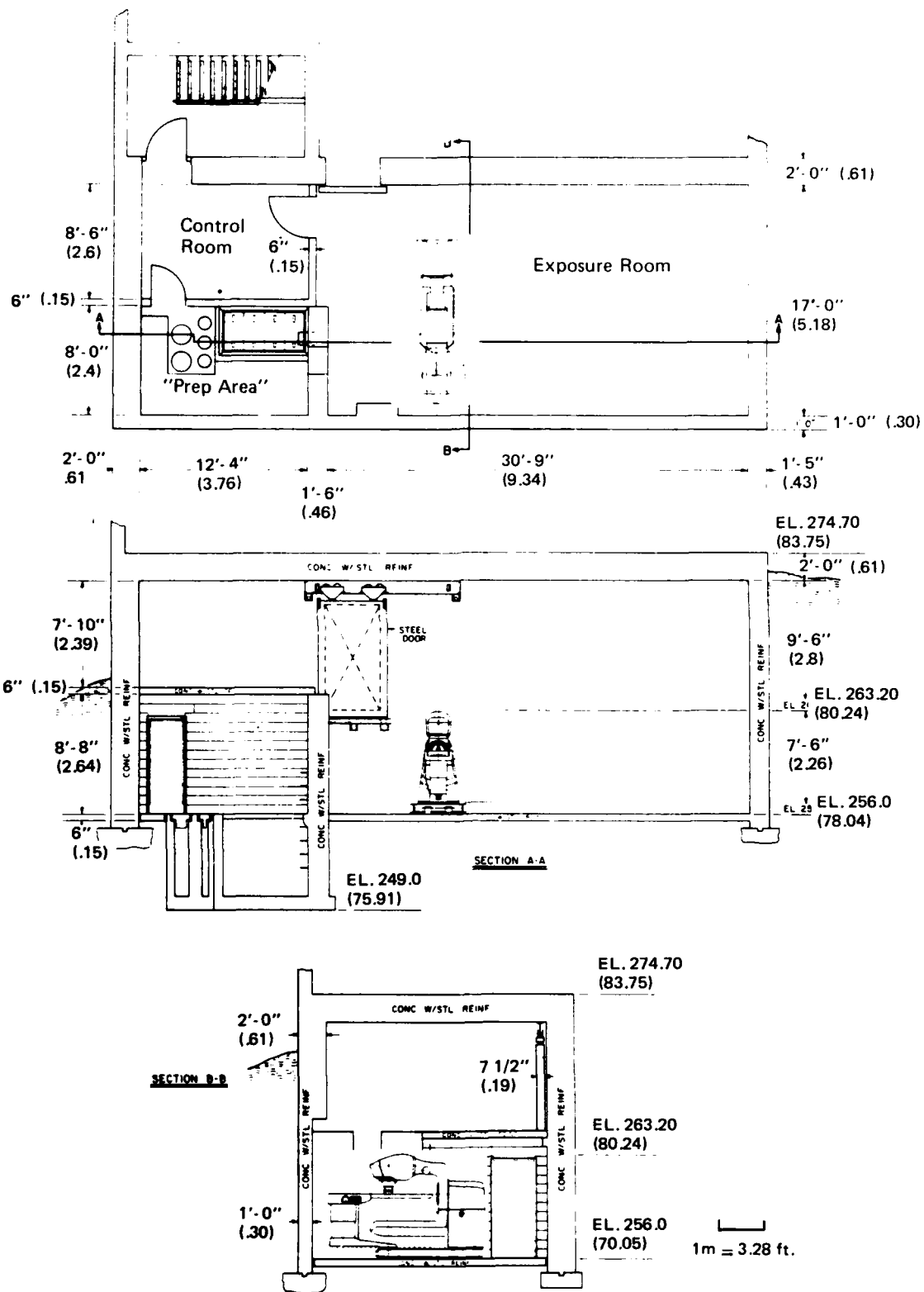

Figure 3. Dimensions of Standards Lab and approximate location of Theratron

The Standards Lab is subdivided into three areas: the Exposure Area, the Control Room, and a room with an open ceiling area, which is to be shielded to provide a Prep Area for experimenters. At present the room has no ceiling and is therefore unshielded. Both the Prep Area and Control Room are 8.67 ft/2.64 m high, and they occupy the west one third of the Standards Lab. The areas above these rooms are open to the exposure area.

The Control Room is 12.33 ft/3.76 m long, 8.5 ft/2.59 m wide, and 8.67 ft/2.64 m high. Its 6-inch/15-m concrete ceiling is reinforced with steel and overlaid with .25 inch/0.635 m of lead. The north and west walls are congruent with the walls of the Standards Lab. The east wall, which separates the Control Room from the Exposure Room, is constructed of 6-inch/15-m cinder blocks. The wall is overlaid with .375 inch/0.953 cm of lead held in place by .75 inch/1.91 cm of wood. The door is a hollow steel door (.0625-inch/0.16-cm sides) overlaid with .75 inch/1.91 cm of lead. In order to increase the shielding provided to the operator, a double row of 7-inch/0.18-m high-density block loaded with iron shot was constructed on the Exposure Room side of the Control Room's east wall. The block wall is 14 inches/0.36 m thick and forms an "L" shape (Figure 4), creating a passageway along the first 5 ft/1.5 m of entrance into the Exposure Room.

The Prep Area is a room 12.33 ft/3.76 m long, 8 ft/2.44 m wide, and 8.67 ft/2.64 m high, and it has no ceiling. The west and south walls are congruent with the corresponding Standards Lab walls. The Prep Area is separated from the Exposure Room by an 18-inch/.46-m-thick concrete wall. The Control Room and Prep Area are separated by a 6-inch/15-cm cinder-block wall. Entrance from the Control Room is through a standard-size, hollow, steel door with .0625-inch/.16-cm-thick steel sides. The south wall of the Prep Area has a 2-ft-square (0.61 m) notch at the top center, filled with concrete blocks loaded with iron shot to a thickness of 14 inch/.36 m).

Aside from the access door, there are three penetrations in the walls of the Standards Lab. Two are penetrations for ventilation ducts through the west wall to the exterior of the building. The third is a penetration for a water sprinkler pipe through the ceiling into Room 2153. The ceiling penetration is shielded with lead bricks.

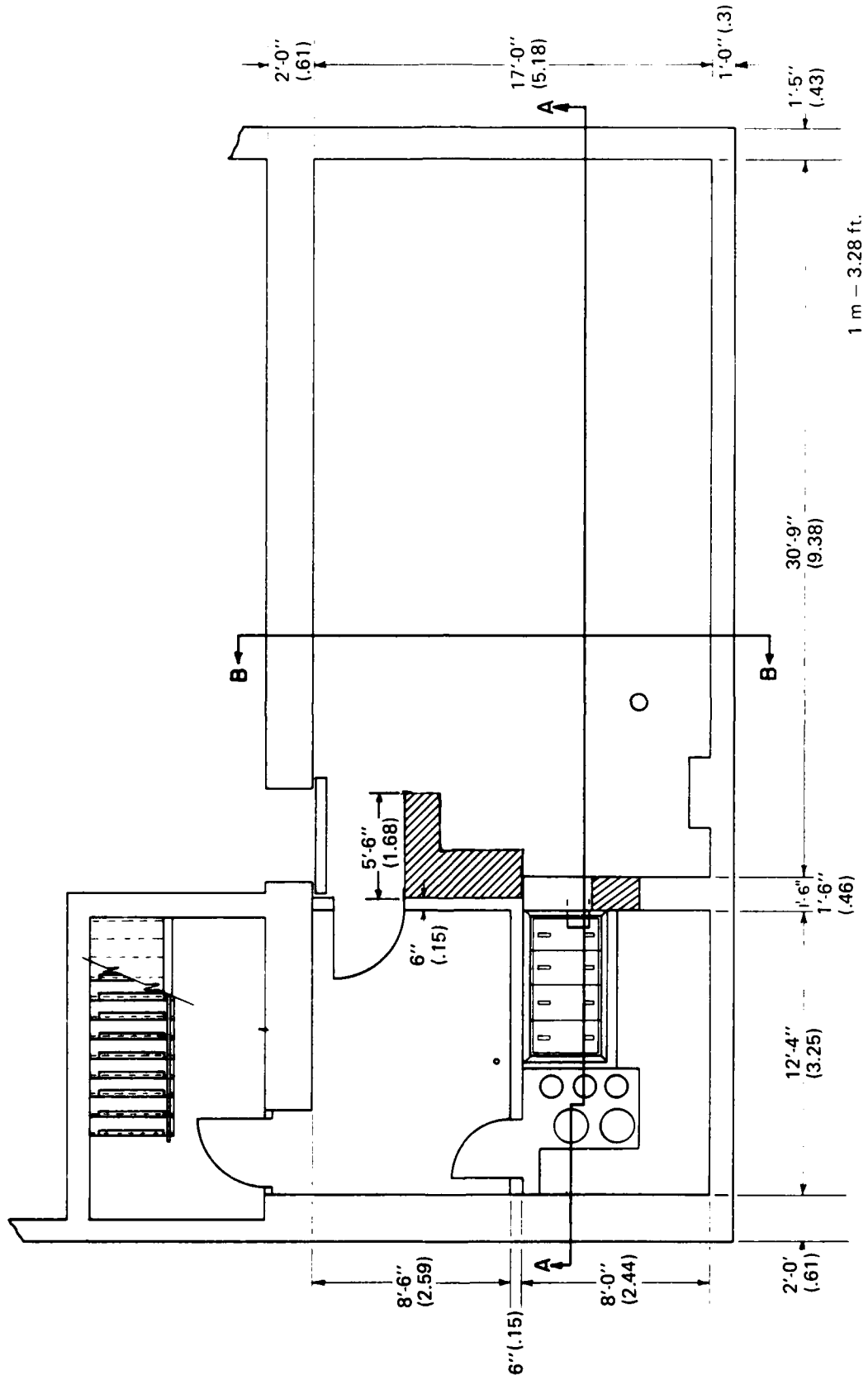

Figure 4. Dimensions of Standards Lab floor and walls, and location of shot-loaded block wall for additional shielding

The following is a short description of the areas adjacent to the Standards Lab (see Figures 5 and 6): Under the Lab is Terra Firma bedrock. South wall: Exterior to Building 42, a walkway is about 18 inches/.46 m from the south wall. The amount of Standards Lab wall that is above ground level along the sloping grade ranges from approximately none on the east end to 8 ft/2.44 m on the west end. Pedestrian traffic is infrequent. East wall: Since the wall is about 1 ft/.3 m below ground level, no portion of it is exposed. A walkway is approximately 3 ft/.91 m from the east wall. Pedestrian traffic is infrequent. West wall: Approximately 8 ft/2.44 m is above ground level. A roadway extends to the base of the wall. Use by pedestrians is infrequent. North wall: The west one third of the wall is adjacent to a stairwell that is seldom used. The east two thirds of the wall is adjacent to the Photo Lab and Darkroom. Occupancy is assumed to be 40 hours per week. Directly above the Standards Lab are Rooms 2151 and 2153 (Director's office), Room 2154 (Secretary's office) and Room 2155 (Education Program Coordinator's office) (Figure 6). These three rooms are also occupied 40 hours per week. The rooms directly above and adjacent to the north wall are a stairwell and a hallway. Their floor is the ceiling of the Standards Lab. Occupancy is infrequent.

DESCRIPTION OF SOURCE

Reference 1 contains the manufacturer's specifications for the Theratron-80 unit. The AFRRRI Theratron differs from that described in the reference in that the AFRRRI unit does not have the readout feature. The salient features of the unit of interest for the shielding survey are described below.

The Theratron-80 is a cobalt-60 moving-beam teletherapy unit designed for rotational or fixed irradiations with a distance of 80 cm from source to axis. The major components are the source head, C-arm, and counterweight/beamstop. The C-arm contains the source head at one end and the counterweight at the opposite end. Figure 3 is a diagram of the Theratron unit.

The source is stored in the source head, which is constructed of a lead and heavy-alloy shield encased in a fireproof cast-steel jacket. When the unit is energized, the source moves via a pneumatic system to a collimating "window" for the irradiation position. The pneumatic system is fail-safe in that the source is returned into the shielded source head if power should fail. The source head is motorized to allow the "window" (and exposed source) to swivel between 0° and 350°. In the normal (unswiveled) position, the "window" directs the radiation toward the counterweight at the opposite end of the C-arm.

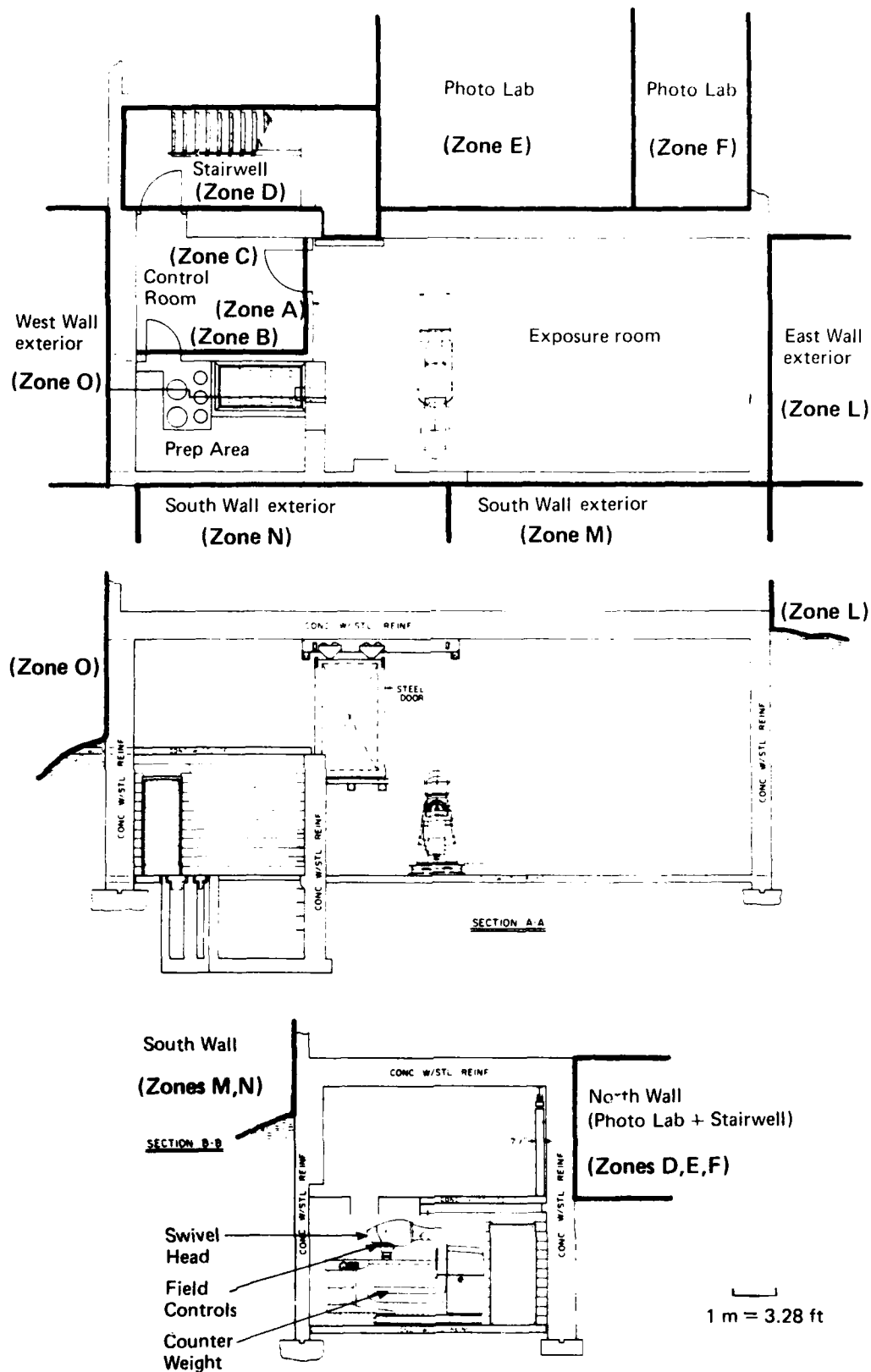

Figure 5. Plan of AFRRI's Standards Lab, showing location of adjacent office spaces and zones used in initial survey

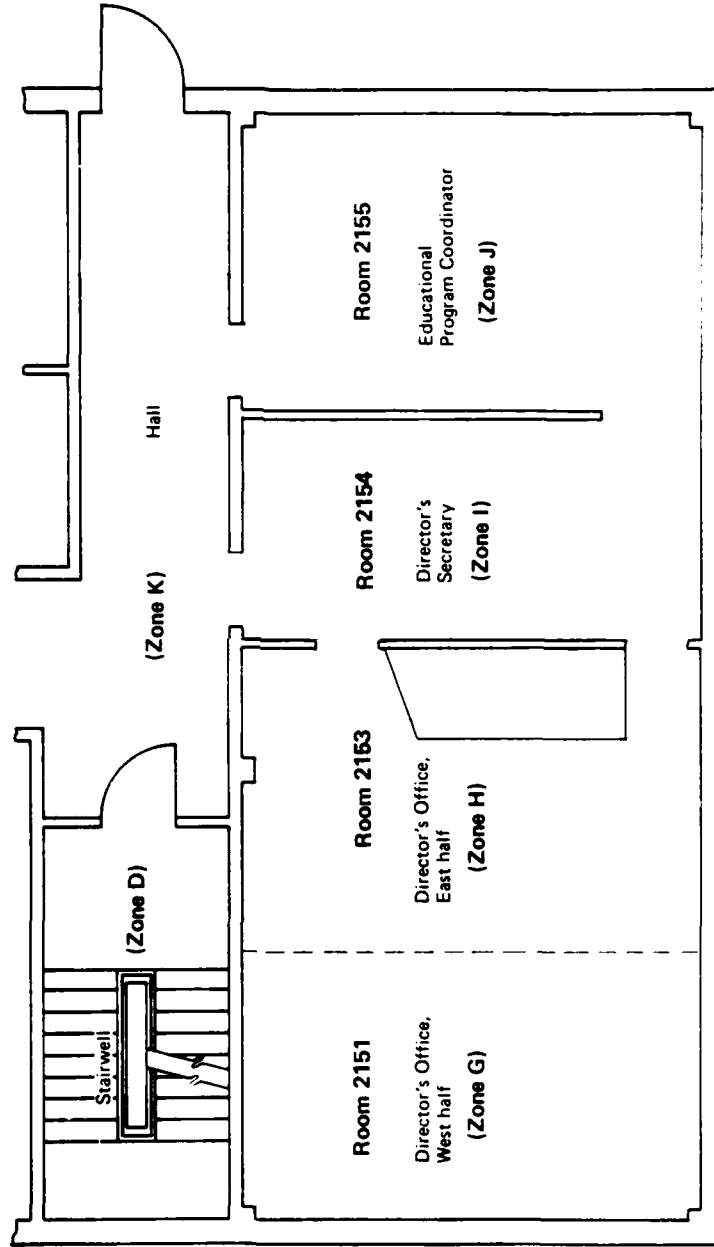

Figure 6. Plan of AFRRI's second floor, showing location of office spaces and zones used in initial survey

The collimator can be adjusted for a maximum field of 33 cm x 33 cm at 80 cm (as defined by the 50% line). The minimum field used in this survey was 5 cm x 5 cm at 80 cm (50% line).

The C-arm is designed so that the axis of rotation is 80 cm from the source. The C-arm is able to undergo continuous rotation of the isocentric arm either clockwise or counterclockwise, from 0° to 360°. As described on page 3 of reference 1, four irradiation modes can be selected on the control console: (a) continuous rotational treatment, (b) skip rotational treatment within a selected segment of rotation scale defined by four magnetic activators that trip the pointer switch, (c) arc oscillation treatment, and (d) fixed treatment for stationary treatment at any preset angle.

The manufacturer's identification of the AFRRRI Theratron is a cobalt-60 source containing 8624 curies as of 10 February 1972, Model No. C-146, Serial No. S-1846. The unit is manufactured by Atomic Energy of Canada, Ltd. (Ottawa, Canada), Model No. Theratron-80, Serial No. 86.

The activity as of 20 March 1980 was 2971 curies. Based on an $I\gamma$ of 1.3, the field strength at 1 meter was 3862 R/hr.

FACILITY INTERLOCKS AND ALARMS

The following alarms/interlocks/indicators are installed as part of the AFRRRI Theratron:

ALARMS

Radiation Area Monitors (RAM's) have been installed to monitor operational and unexpected radiation levels in the following six areas:

Control Room

The detector is directly above the Exposure Room entrance, about 7 ft/2.1 m above the floor.

Freight Door

The detector is located directly outside and 6 ft/1.83 m from the freight door, about 7 ft/2.1 m above the stairway landing at the freight door. It acts as a streaming monitor for that entrance.

East Wall

The detector is 9 ft/2.74 m to 10 ft/3.05 m above the floor along the centerline of the vertical axis of the field of a horizontal beam projection, on the east wall of the Exposure Room. This RAM is positioned to detect any misalignment of the Theratron head when it is in the projected beam mode.

South Wall

This detector is located near the head of the Theratron, on the south wall of the Exposure Room, about 6 ft/1.83 m above the floor. It is positioned and its alarm point chosen to give an alarm whenever the source is open.

Director's Office

The detector is located above the false ceiling in Room 2153, near the south door leading to Room 2154, and is approximately 9 ft/2.74 m above the floor. It is positioned at the point of maximum penetration of radiation if the source were rotated with the head misaligned relative to the beam stop.

Prep Area

In the Prep Area, the detector is about 6 ft/1.83 m above the floor, next to the door.

INTERLOCKS

An interlock on the Exposure Room entry door deenergizes the Theratron if entry is made through the Control Room door while the Theratron is energized. This interlock also initiates an audible alarm and a visual alarm. Both alarms can be perceived at the doorway before a person actually enters the room.

As an added precaution, an interlock on the freight access door into the Exposure Room prevents the Theratron from operating if the door is unlocked. The door can be unlocked and opened from only the inside of the Exposure Room.

A clearly labeled emergency shutdown mechanism is located in the Exposure Room to allow a person to prevent the machine from being energized and subsequently operated while personnel are in the room.

If personnel are in the Exposure Room when the Theratron is energized, they can readily open the Control Room entrance door (which is secured and interlocked from outside the Control Room), to allow exit from the Exposure Room. The machine is shut down when the interlocked door is opened from the inside (Exposure Room side).

The Theratron is activated through two keyed switches on the control console. One supplies energy to only the source, and the other supplies energy to all other electrical circuits. If the electrical connection is broken by an interlock for any reason, the source key must be turned on for delivery of power to the source. The "machine reset" at the control panel cannot be reset unless the source switch is turned on.

Although four methods of operation are possible from the control panel (i.e., fixed, rotational, ARC, and skip) (see pages 3, 6, and 7 of reference 1), only the fixed position is routinely allowed. At present a plastic cap has been placed over the rotational, ARC, and skip selector switches and secured to the console. This prevents initiation of one of these modes of operation without intentional removal of the cap.

No interlock is presently on the Prep Area entrance to deenergize the Theratron if someone should enter that area. Eventually, shielding will be placed to reduce all radiation levels in this area. Absolute control of access is maintained by giving the operator sole control of the key. The room will not be used as a prep area until all shielding requirements are met. Radiation levels present in this area are listed in the section on Survey.

INDICATORS

When the machine is turned on, there is a 20-sec delay. During this delay an audible alarm sounds for 20 sec inside the Exposure Room and a rotating beacon turns on. The beacon continues throughout the irradiation.

All RAM's display a local and a remote meter readout, and activate a visual alarm if the set point is exceeded. The remote meter reading and visual alarm are located in the Control Room.

An amber light to indicate that the source is on is located above the Exposure Area access door in the Control Room. This light is activated by the RAM located inside the Exposure Room on the south wall near the source head. Hence it is completely independent of all Theratron control circuits.

In addition to the amber light above the Exposure Area door, an amber light on the south wall of the Exposure Room acts as a source-on light. A source-on light is also displayed on the remote RAM readout panel in the Control Room.

If the Exposure Room door from the Control Room is opened while the Theratron is activated, an alarm will sound in addition to a visual alarm.

MODES OF OPERATION

The radiation fields of the Theratron-80 are primarily affected by three components, which allow a wide variety of operations. These sections are the field size controls, C-arm and counterweight, and swivel head (see Figure 5). The field size can be adjusted from a 5 cm to 33 cm square at 80 cm distance (as defined by the 50% line) with the trimmers retracted to a 45-cm source to diaphragm distance. The C-arm and counterweight can be rotated in either clockwise or counterclockwise direction from 0° to 360°. The source head, at the end of the C-arm, is free to swivel through an angle of 180° clockwise and 170° counterclockwise from the normal position (i.e., beam directed at counterweight or toward center of rotation). With the source head in a position other than normal, only stationary C-arm and counterweight irradiations are possible. If the source head is in the normal position, these four irradiation modes can be used: stationary C-arm, continuous isocentric rotation, arc oscillation, and skip rotational irradiation. These modes can be selected from the control panel. All field sizes are possible for all modes of operations. As installed, the AFRI Theratron will operate in only the fixed modes. The continuous rotational, arc oscillation, and skip modes have been mechanically eliminated from normal use by a restraining device (described under Interlocks in the section on Facility Interlocks and Alarms).

Although the only planned irradiation modes are the swivel head in the normal position with the beam directed toward the ground (and counterweight) and the beam directed horizontally parallel to the ground toward the east wall, no mechanical interlocks have been installed to prevent other angles of swivel and/or C-arm irradiations.

SURVEY

Radiological survey of the Theratron was done during six irradiations. Table 1 gives pertinent information (day, operator, involved personnel, personnel background, instruments used, and goal) for the particular irradiation. All instruments were calibrated before and after the initial survey, to ensure proper functioning of all instruments that revealed no radiation. In all subsequent irradiations, all instruments were maintained in routine calibration and checked for operability at the time of their use.

Table 1. Summary of Survey

PERSONNEL	BACKGROUND	INSTRUMENTS
<u>20 March 1980, vertical beam, directed down, Operator LT Ferlic</u>		
Dr. Arras	Chief, Radiation Health Physics Division, CHP	HP 1060 #104 Ludlum 181"x1"NaI C-0098, C-0096
Mr. Bransford	Senior Dosimetry Technician	Teletector 06112B
LCDR Durfee	Health Physics	Thyac II 376
LT Ferlic	Radiation Physicist/Dosimetrist	Thyac II 739
Mr. Flory	Health Physicist	Thyac II 371
HM1 Frost	Nuclear Medicine Technician	Thyac III 3217
LT Jacobus	Health Physicist	Thyac III —
Maj Johnson	Radiation Physicist/Dosimetrist	Victoreen 493 #828
HMC Pryor	Nuclear Medicine Technician	Victoreen 493 #
SP5 Smoral	Chemical Lab Specialist	Victoreen 493 #
<u>15 April 1980, rotational mode, beam directed toward center, Operator LT Ferlic</u>		
Dr. Arras	Chief, Radiation Health Physics Division, CHP	HP 1060
LT Ferlic	Radiation Physicist/Dosimetrist	Ludlum #3 with pancake
HMC Kumano	Nuclear Medicine Technician	Victoreen 493, One unrecorded survey instrument.
<u>29 April 1980, horizontal beam, Operator LT Ferlic</u>		
LT Ferlic	Radiation Physicist/Dosimetrist	Thyac #376
Mr. Slaback	Head, Safety Department, CHP	Ludlum Model 18 C- 0096, Probe C-0098, LIF-TLD
<u>14 May 1980, vertical beam, directed down, Operator HM1 Frost</u>		
LT Ferlic	Radiation Physicist/Dosimetrist	LiF-TLD
HM1 Frost	Nuclear Medicine Technician	
<u>20 May 1980, horizontal beam, aligned and misaligned, Operator HM1 Frost</u>		
LT Ferlic	Radiation Physicist/Dosimetrist	Radiation area monitor
HM1 Frost	Nuclear Medicine Technician	
<u>19 June 1980, horizontal beam, Operator LT Ferlic</u>		
LT Ferlic	Radiation Physicist/Dosimetrist	Thyac II
SP6 Vernon	Primary Power Production Specialist	Ludlum Model 18 Victoreen 443, #92287

To facilitate the acquisition of data and analysis of the survey, the areas to be surveyed were divided into zones. Each zone was divided into regions. Only positive readings above background were recorded. All other areas were simply noted as being "background." The zones were as follows:

- Zone A: Control Room, east wall
- Zone B: Control Room, south wall
- Zone C: Control Room, ceiling
- Zone D: Stairwell and freight door
- Zone E: West half of Photo Lab's south wall
- Zone F: East half of Photo Lab's south wall
- Zone G: West half of Director's office (Room 2152)
- Zone H: East half of Director's office (Room 2153)
- Zone I: Director's secretary's office (Room 2154)
- Zone J: Education Program Coordinator's office (Room 2155)
- Zone K: Hall, second floor
- Zone L: Outside east wall
- Zone M: Outside south wall, east half
- Zone N: Outside south wall, west half
- Zone O: Outside west wall

Figures 5 and 6 show the various zones used in the survey. Since penetration varies greatly because of the source position, the data obtained during each irradiation are summarized according to the date of irradiation. The numbers in parentheses following the exposures/doses are the pro-rated exposures/doses based on maximum source loading under the license (4,000 curies). The particular pro-rating factor for the specific date of the survey is given directly after the date. An overall summary is found in the section titled Summary Evaluation.

SURVEY OF 20 MARCH 1980 (PRO-RATE FACTOR 1.35)

Two irradiations were performed during the 20 March 1980 survey. In each, a large phantom (8 in x 24 in x 20 in/20.32 cm x 60.96 cm x 50.8 cm) was placed at 80 cm from the source with maximum field (33 cm x 33 cm). Only positive readings above background were recorded. Particular areas higher than the general regions were identified. For any area not specifically listed, the readings for the area were not greater than the background.

First Irradiation: Source Directed Down Toward Ground Into Counterweight

<u>Zone A:</u>	Generally	0.1 mR/hr (0.14)
	Top right corner (facing wall)	0.5 mR/hr (0.67)
<u>Zone B:</u>	Generally	0.1 mR/hr (0.14)
	At door into Prep Area (closed)	0.8 mR/hr (1.1)
	Top of wall, left center (facing)	0.5 mR/hr (0.67)
<u>Zone C:</u>	Generally	0.1 mR/hr (0.14)
	Top right corner (facing Zone A)	0.2 mR/hr (0.27)
	Above Prep Area door	0.2 mR/hr (0.27)
<u>Zone D:</u>	Steel freight door, generally	0.1 mR/hr (0.14)
	At steel freight door, lower left corner	1.5 mR/hr (2.0)
<u>Zone O:</u>	Pipe penetration through west wall, at center of pipe	0.3 mR/hr (0.41)
<u>Prep Area:</u>	At door, with door open	8 mR/hr (11)
	Middle of room	15 mR/hr (20)
	Top of wall sepa- rating Exposure Room and Prep Area	150 mR/hr (200)

Second Irradiation: Source Directed up Toward Ceiling Into Counterweight

<u>Zone A:</u>	Generally	0.1 mR/hr (0.14)
	Top right corner (facing)	1 mR/hr (1.4)
	Top right region	0.4 mR/hr (0.54)

<u>Zone B:</u>	Generally	0.2-0.3 mR/hr (0.27-0.40)
	Left corner region	0.5-0.7 mR/hr (0.67-0.94)
	Door to Prep Area, near top of closed door	Up to 2 mR/hr (2.7)
<u>Zone C:</u>	Generally	About 0.2 mR/hr (0.27)
	Near middle of ceiling	0.4 mR/hr (0.54)
<u>Zone D:</u>	Steel freight door, lower corner	1.5 mR/hr (2.0)
<u>Zone H:</u>	Near middle of room, in circular area	Up to 0.6 mR/hr (0.82)
	Coffee mess area (behind closet) near pipe penetration	0.5 mR/hr (0.67)
<u>Zone I:</u>	Near east wall of Room 2154, at center of floor (under secre- tary's desk)	0.2 mR/hr (0.27)
<u>Zone N:</u>	Up against the wall, about 4-6 ft/1.22- 1.83 m in from the southwest corner and about 18 inches/ 0.46 m up	0.1-0.15 mR/hr (0.14-0.20)
<u>Zone O:</u>	Wall penetrations, at center of pipes	0.5 mR/hr (0.67) and 1.0 mR/hr (1.4)
<u>Prep Area:</u>	Open door, in doorway	8 mR/hr (11)
	Three ft/0.91 m in room, at chest level	20 mR/hr (27)
	Center of room	25 mR/hr (34)
	Top of wall	100 mR/hr (140)

Summary of 20 March 1980 Survey

This survey revealed that the pipe penetrations in the west wall were voids and that additional shielding would be required. In addition, although they were not high, some measurable dose rates were measured in the Control Room and through the second floor. Dose assessments appear in this report in the section on Summary Evaluation, for the mode of operation in which the beam is directed downward. The minor streaming leakage that was observed at the edge of the freight door can be controlled easily by keeping closed the wooden barrier for the freight door. Radiation levels in the "to be Prep Area" indicated that shielding would be required. Shielding calculations for this area are provided in Appendix A.

It is to be noted that a reasonable measurement was made in Zone H (Director's Office) for the beam directed upward (into the beamstop). Since this was not going to be a mode of operation submitted for approval of the Reactor and Radiation Facility Safety Committee, no further evaluation was made. If this position is to be used, an attempt at maximizing the penetration and subsequent estimates of personnel dose will be needed.

SURVEY OF 15 APRIL 1980 (PRO-RATE FACTOR 1.36)

The 15 April 1980 survey generally evaluated the rotational mode in the Control Room, Director's office, and Director's secretary's office for the existence of any significant penetrations. The survey is not a complete evaluation of the rotational mode. Readings were taken at 30° intervals except where penetration increased. Then 15° intervals were taken. In all cases the phantom (26 in x 20 in x 8 in/66.04 cm x 50.8 cm x 20.32 cm) was placed as close as possible to the source head while lying on the patient table. Field size was maximum for all irradiations. Only positive readings above background in the regions surveyed were recorded. Tables 2-4 summarize the data from the survey.

Summary of 15 April 1980 Survey

Survey data indicated that various positions in the rotational mode could produce measurable penetrations through the second floor. In addition, the alarm survey data (Table 2) showed that the south wall RAM (radiation area monitor) is a very good source-on indicator, since it receives a consistent amount of scatter radiation for all positions on the arc of rotation.

Table 2. RAM Readings and Scatter Distance From Source for 15 April 1980 Survey (Pro-rated Values)

Angle (degrees)	SSD* (cm)	East Wall (mR/hr)	South Wall (mR/hr)	Director's Office (mR/hr)
30	56.5	60 (82)	400 (600)	0.40 (0.60)
60	50.0	100 (140)	400 (600)	0.45 (0.61)
90	47.5	10 (14)	400 (600)	0.45 (0.61)
120	47.5	60 (82)	500 (680)	0.45 (0.61)
135	47.5	100 (140)	400 (600)	0.50 (0.68)
150	50.0	20 (27)	500 (680)	0.50 (0.68)
165	50.0	20 (27)	450 (610)	0.50 (0.68)
180	50.0	20 (27)	450 (610)	0.50 (0.68)
195	53.0	25 (34)	400 (600)	0.50 (0.68)
210	25.0	20 (27)	350 (480)	0.45 (0.61)
225	51.0	22 (30)	350 (480)	0.45 (0.61)
240	55.0	10 (14)	300 (410)	0.50 (0.68)
255	55.0	40 (60)	600 (820)	0.50 (0.68)
270	47.5	2 (2.7)	500 (680)	0.50 (0.68)
300	50.0	8 (11)	500 (680)	0.50 (0.68)
330	55.0	20 (27)	500 (680)	0.45 (0.61)

*Scatter distance from source

It is to be noted that data in Tables 3 and 4 are not symmetric about the arc of rotation. This appears to be due to the facts that in one case, the beam is directed away from the second floor into the beamstop and in the "symmetric" case (on the other side of the arc), the beam is directed toward the second floor through the beamstop. Consequently there is no real symmetry in the arc mode relating to penetration through the second floor. This survey was preliminary for the gross evaluation of penetration problems for irradiations other than 0° (beam directed down into beamstop away from the second floor). This survey should not be considered adequate for any of the identified positions since no attempt was made to maximize the penetrations and evaluate the dose estimates.

Table 3. Second-Floor Readings for 15 April 1980 Survey (Pro-rated Values)

Angle	Room 2151			Room 2153			Room 2154					
	A	B	C	D	E	F	G	H	I	J	K	L
30	-	-	-	-	-	-	-	-	-	-	-	-
60	-	-	-	-	-	-	-	-	-	-	-	-
90	-	-	-	-	-	-	-	-	-	-	-	-
120	-	-	-	-	.06 (.08)	.15 (.2)	.08 (.11)	.26 (.4)	-	-	-	-
135	-	-	-	-	.2 (.3)	.14 (.2)	.35 (.48)	.22 (.30)	-	.32 (.44)	-	-
150	.2 (.3)	.04 (.05)	-	-	.13 (.12)	.28 (.4)	.35 (.5)	.17 (.23)	-	.46 (.63)	-	-
165	-	-	.24 (.33)	-	.13 (.12)	.29 (.4)	.09 (.12)	.17 (.23)	-	-	-	-
180	-	-	.18 (.24)	-	.14 (.19)	-	-	-	-	-	-	-
195	-	-	.03 (.04)	-	.05 (.07)	.04 (.05)	.04 (.05)	.16 (.22)	.13 (.18)	-	-	-
210	-	-	-	-	.07 (1.0)	.09 (.12)	.23 (.31)	.30 (.41)	-	.11 (.25)	.29 (.40)	-
225	-	-	.04 (.05)	.04 (.05)	.06 (.08)	.22 (.3)	.14 (.2)	.23 (.3)	-	.05 (.07)	.12 (.16)	.21 (.29)
240	-	-	.06 (.08)	-	.10 (.14)	.11 (.15)	.08 (.11)	.12 (.16)	-	.03 (.04)	.12 (.16)	.13 (.18)
255	-	-	.05 (.07)	-	.03 (.04)	.08 (.11)	.03 (.04)	.03 (.04)	-	-	.04 (.08)	-
270	-	-	-	-	-	-	.05 (.07)	.03 (.04)	-	-	.04 (.05)	-
300	-	-	-	-	-	-	-	-	-	-	-	-
330	-	-	-	-	-	-	-	-	-	-	-	-

* All readings are in mR/hr.

- A - Center east side of floor
- B - Southeast section of floor
- C - Center of floor
- D - East center of floor up to east wall
- E - South center of floor up to south wall
- F - Southeast floor, corner of room
- G - West center of room up to west wall
- H - Center of room
- I - East center of room up to east wall
- J - Southwest corner of floor
- K - South center of room up to south wall
- L - Southeast corner of floor

Table 4. Control-Room Readings* for 15 April 1980 Survey (Pro-rated Values)

Angle	A	B	South Wall	C	D	E	F	East Wall	G	H	I	J	K
30	0.4 (0.54)	0.4 (0.54)	-	-	-	-	-	-	-	-	-	-	-
60	0.3 (0.41)	0.3 (0.41)	0.2 (0.3)	-	-	-	-	-	-	-	-	-	-
90	0.6 (0.82)	0.7 (1.0)	0.6 (0.82)	-	-	-	-	-	-	-	-	-	-
120	0.8 (1.1)	NRR	0.8 (1.1)	1.1 (1.5)	-	-	-	-	-	-	-	-	-
135	1.1 (1.5)	NRR	1.3 (1.8)	1.3 (1.8)	-	-	-	-	-	-	0.15 (0.2)	-	-
150	1.3 (1.8)	1.5 (2.0)	1.3 (1.8)	-	-	-	0.55 (0.75)	-	-	-	-	-	-
165	1.0 (1.4)	1.7 (2.3)	1.4 (1.9)	1.4 (1.9)	-	-	0.95 (1.3)	-	-	-	-	-	0.2 (0.3)
180	1.0 (1.4)	1.4 (1.9)	1.3 (1.8)	1.4 (1.9)	-	-	1.0 (1.3)	0.5 (0.7)	-	-	0.2 (0.3)	-	0.2 (0.3)
195	1.5 (2.0)	1.5 (2.0)	1.6 (2.2)	1.8 (2.4)	0.4 (0.54)	-	1.3 (1.8)	0.9 (1.22)	-	0.6 (0.82)	0.2 (0.3)	0.2 (0.3)	0.15 (0.2)
210	0.5 (0.7)	1.5 (2.0)	0.5 (0.7)	NRR	NRR	0.1 (0.14)	2.5 (3.4)	1.5 (2.0)	-	0.8 (1.1)	NRR	0.3 (0.4)	0.2 (0.3)
225	0.3 (0.41)	0.3 (0.41)	0.3 (0.41)	0.3 (0.41)	NRR	0.2 (0.3)	4.0 (5.4)	5.0 (6.8)	-	1.4 (1.9)	NRR	0.4 (0.5)	0.15 (0.2)
240	0.2 (0.3)	0.2 (0.3)	0.2 (0.3)	0.2 (0.3)	NRR	0.1 (0.14)	0.2 (0.3)	5.0 (6.8)	-	3.5 (4.8)	-	0.2 (0.3)	0.2 (0.3)
255	0.8 (1.1)	0.4 (0.54)	0.8 (1.1)	0.8 (1.1)	NRR	0.15 (0.2)	-	-	-	1.5 (2.5)	-	0.2 (0.3)	0.2 (0.3)
270	1.5 (2.0)	2.5 (3.4)	1.5 (2.0)	1.5 (2.0)	NRR	0.2 (0.3)	0.4 (0.54)	-	-	-	0.3 (0.4)	0.3 (0.4)	0.3 (0.4)
300	1.5 (2.0)	2.5 (3.4)	1.5 (2.0)	1.5 (2.0)	NRR	0.3 (0.41)	3.3 (4.5)	10.0 (13.6)	-	2.5 (3.4)	0.8 (1.1)	0.7 (1.0)	0.3 (0.4)
330	0.5 (0.7)	0.2 (0.3)	0.5 (0.7)	0.5 (0.7)	NRR	0.1 (0.14)	0.8 (1.1)	1.0 (1.4)	-	2.8 (3.4)	0.4 (0.5)	0.4 (0.5)	0.15 (0.2)

*All readings are in m R/hr

- A - Vent penetration, control room, right
- B - Vent penetration, control room, left
- C - Closed door to prep area, middle
- D - Closed door to prep area, top
- E - Middle, general
- F - Upper right corner
- G - Middle right corner
- H - Lower right corner
- I - West half
- J - South half and southeast section
- K - Middle of room
- NRR - No recorded reading

SURVEY OF 29 APRIL 1980 (PRO-RATE FACTOR 1.37)

The 29 April 1980 survey evaluated the horizontal mode of operation. A large phantom (8 in x 20 in x 24 in/20.32 cm x 50.8 cm x 60.96 cm) was placed as close as possible to the source (45 cm), with a maximum field setting. A 254° rotation with a 15° swivel was used to align the beam horizontal to the floor. Only positive readings above background were recorded. All areas adjacent to the exposure room were evaluated.

Two irradiations were done to evaluate a severe misalignment: an aligned horizontal beam and a beam 13° up off the horizontal.

Horizontal Beam

Data for the aligned horizontal beam are as follows:

Control Room (Zones A, B, and C)

Door into Prep Area	1 mR/hr (1.4)
South wall maximum	0.2 mR/hr (0.27)

Prep Area

Door open	2 mR/hr (2.7)
Three ft/.91 m in	10 mR/hr (14)
Center of room	14 mR/hr (19)

Zone D

At steel door	0.05 mR/hr (0.07)
Center of steel freight door	0.45 mR/hr (0.62)
Midway up steel door at the gap between the door and the face of the wall, east side	1.0 mR/hr (1.4)

Zone I (Room 2154) (a = Victoreen G-M; b = Ludlum NaI)

Center of floor, west section	0.01 mR/hr (0.014)
Center of floor	0.02 mR/hr (0.03)
Center of floor, east section	0.15 mR/hr (0.21) ^a / 0.03 mR/hr (0.04) ^b
Southwest corner section	0.01 mR/hr (0.014) ^b
Center of floor, south section	0.05 mR/hr (0.07) ^a / 0.02 mR/hr ^b (0.03)
Southeast corner section	0.1 mR/hr (0.14) ^a / 0.03 mR/hr ^b (0.04)

Zone J (Room 2155)

Center of floor, west section	0.03 mR/hr (0.04)/ 0.06 mR/hr (0.08)
Southwest corner section	0.014 mR/hr (0.02)
Center of floor, south section	0.01 mR/hr (0.014)
Southeast corner section	0.01 mR/hr (0.014)

Zone L

At ground-wall interface, about 6-7 ft/1.83-2.13 m in from south- east corner of building	0.5-0.6 mR/hr (0.7-0.8)
At edge of sidewalk, 3 ft/0.91 m off ground	0.1 mR/hr (0.14)

Misaligned Horizontal Beam

Data for a beam 13° up off the horizontal are as follows:

Control Room (Zones A, B, and C)

Center of room	0.1 mR/hr (0.14)
Center of door to Prep Area	1.8 mR/hr (2.5)
South wall maximum	0.2 mR/hr (0.27)
Ceiling near Prep Area door	0.2 mR/hr (0.27)

Prep Area

Door open	4 mR/hr (5.5)
Three feet (0.91 m) in	10 mR/hr (14)
At Prep Area center	20 mR/hr (27)

Zone D

Steel freight door on contact in center	0.1 mR/hr (1.4)
Steel freight door area	0.05 mR/hr (0.07)

Zone I (Room 2154)

Center, north section	0.05 mR/hr (0.07)
Northeast corner section	0-0.1 mR/hr (0-0.14)
Center, west section	0-0.5 mR/hr (0-0.7)
Center	0.1 mR/hr (0.14)
Southwest corner section	0.1 mR/hr (0.14)
South center	0.1-0.2 mR/hr (0.14-0.28)
Southeast corner	0.2-0.25 mR/hr (0.27-0.34)

Zone J (Room 2155)

Hot spot 5 ft/1.52 m from south wall, 4 ft/1.22 m from west wall, drops off in all four directions	0.03 mR/hr (0.04)
At center of west wall	0.1 mR/hr (0.14)
Center, south section, localized maximum	0.06 mR/hr (0.08)

Zone L

At wall, ground level, 5 ft/1.52 m from corner	1.8 mR/hr (25)
At edge of wall, 3 ft/0.91 m off ground	0.1-0.12 mR/hr (0.14-0.16)
At wall, ground level, 10 ft/3.05 m from corner	Dose levels drop by a factor of 10.

Summary of 29 April 1980 Survey

The survey data indicated that the horizontal mode could produce measurable levels on the second floor and in the previously identified areas (freight door streaming and Prep Area). It was observed that further investigation will be needed to maximize the scatter through the second floor to evaluate the worst case levels.

SURVEY OF 14 MAY 1980 (PRO-RATE FACTOR 1.375)

The survey of 14 May 1980 was a 60-min, vertical beam irradiation with beam directed toward the ground. Maximum field was used with the phantom at 61 cm. Thermoluminescent dosimeters (TLD's) were placed at various locations in the Exposure Room to assess the dose rates at those locations. The purpose of the survey was to estimate the exposure to an operator if he/she were required to enter the room with the beam on. The vertical position was chosen since it maximizes the exposure an operator would receive. In the horizontal mode, the operator would enter and deenergize the source from behind the source and 180° from the direction of the beam. In the vertical position it is necessary to stand parallel to the beam and receive the 90° scatter irradiation. Figure 7 is a diagram of the locations of the TLD's. The TLD positions and readings are listed below.

<u>Position 1:</u> On a phantom surface at beam center	9.461 x 10 ⁶ mR/hr (1.3 x 10 ⁷)
<u>Position 2:</u> 90° from beam at a distance of 53 cm at chest height	1.54 x 10 ⁴ mR/hr (2.12 x 10 ⁴)
<u>Position 3:</u> Corner of maze wall approximately 4 ft/1.22 m high at 90° from beam (distance 240 cm)	770 mR/hr (1.06 x 10 ³)
<u>Position 4:</u> North wall at edge of maze, 90° from beam at 385 cm	300 mR/hr (412)
<u>Position 5:</u> On Exposure Room side of door at a height of 4 ft/1.22 m	81 mR/hr (14)
<u>Position 6:</u> On cesium source at 198 cm from beam center at 90°	1.57 x 10 ³ mR/hr (2.56 x 10 ³)
<u>Position 7:</u> On top of wall of Prep Area at 340 cm from scatter	82 mR/hr (113)
<u>Position 8:</u> In Prep Area, center of room, 7 ft/2.13 m high	56 mR/hr (77)
<u>Position 9:</u> In Prep Area, center of room, 4 ft/1.22 m high	47 mR/hr (65)
<u>Position 10:</u> In Prep Area door at a height of 4 ft/1.22 m, at approximately 5.5 ft/1.68 m from Position 9	42 mR/hr (58)

Summary of 14 May 1980 Survey

Radiation levels for positions other than near the source head are relatively low; that is, the levels will not exceed a dose of 50 mrem/day for a reasonable stay time. Obviously, as the source head is approached, high dose rates occur. Dose estimates for an emergency shutdown appear in the section on Summary Evaluation.

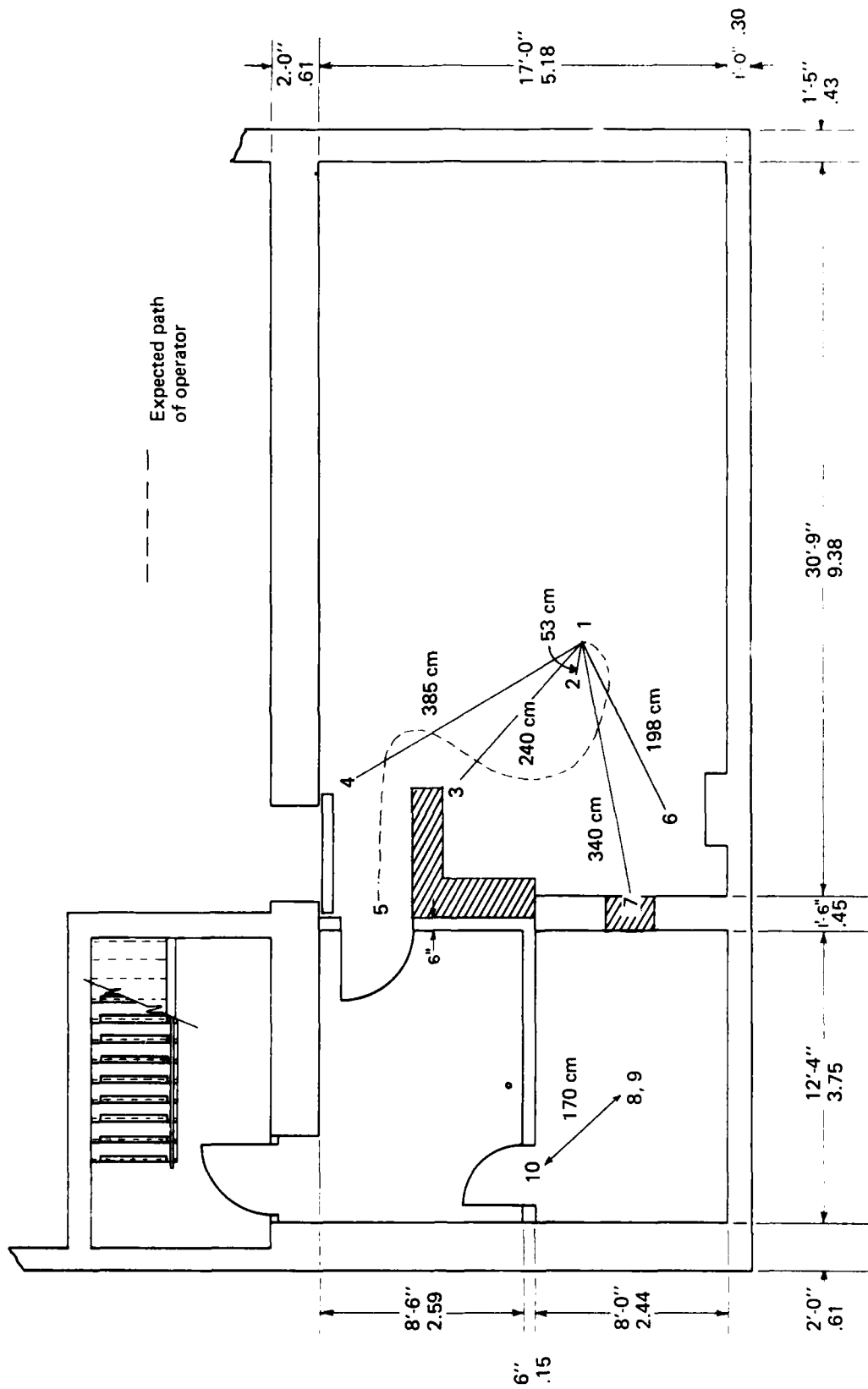

Figure 7. Location (including distance) of thermoluminescent dosimeters used in assessing an emergency entrance dose while source is open

SURVEY OF 20 MAY 1980 (PRO-RATE FACTOR 1.38)

The 20 May 1980 survey was a preliminary survey to evaluate the magnitude of the scattered radiation toward the east wall for various configurations of the horizontal mode. See Table 5.

Table 5. Survey Data of 20 May 1980

A. Detector 3.0 m up from floor and 0.5 meter away from east wall along centerline of field; C-arm held at 254° rotation (all readings in mR/hr)								
Swivel (head)	165	155	160	163	165	155	150	
Misalignment from horizontal (°)	0	10	5	2	0	10	15	
Field size	Open	Open	Open	Open	Closed	Closed	Closed	
Reading (mR/hr)	1.5K	100K	2K	1.6K	500	500	1K	
Pro-rate	(2.1K)	(138K)	(2.76K)	(2.2K)	(689)	(689)	(1.38K)	
B. Probe 3 m high, against wall; C-arm held at 254° rotation (all readings in mR/hr)								
Swivel (head)	63	165	160	155	155	165	163	160
Misalignment from horizontal (°)	2	0	5	10	10	0	2	5
Field size	Open	Open	Open	Closed	Closed	Open	Open	Open
Reading (mR/hr)	1K	900	1.7K	450	200	1.3K	1.4K	1.5K
Pro-rate	(1.38K)	(1.24K)	(2.34K)	(620)	(276)	(1.8K)	(1.9K)	(2.1K)
Phantom	No	No	No	No	Yes	Yes	Yes	Yes

Summary of 20 May 1980 Survey

This survey was an attempt to evaluate a reasonable operational set point for the horizontal mode for the east wall to alarm on a misaligned narrow beam but not alarm from the scatter from a maximum-field experiment. A set point of 10^3 R/hr was determined to be adequate for the phantom used, to meet both conditions above.

SURVEY OF 19 JUNE 1980 (PRO-RATE FACTOR 1.39)

The 19 June 1980 survey was to accomplish four tasks, as follows:

1. After placement of the shielding, check penetration of radiation through vents on the west wall.
2. Evaluate an alarm set point for the east wall RAM based on the horizontal mode.
3. Assure that the alarm set point will be properly triggered for a misaligned narrow beam.
4. Attempt to maximize radiation levels through the ceiling into occupied areas for the horizontal mode due to scattered radiation from exposed objects of various sizes.

Task 1

During the 20 March survey, penetration was observed through the vents in the west wall to the exterior of AFRRI during the beam-down position. Lead shielding measuring 0.25 inch was placed over the vent. Subsequent measurements indicated that no penetration had occurred. During this run, a reading of 0.5 mR/hr was obtained in the Control Room at the closed Prep Room door. When the Prep Room door was open, a reading of 4 mR/hr was obtained at the same point. The door consists of approximately 2 inches/5.08 cm of air and two .0625-inch/0.16-cm sheets of iron. Attenuation by a factor of 0.125 through 0.125 inch/0.32 cm (neglecting air) steel (iron 7.87 g/cc) would indicate an attenuation coefficient of approximately $0.8 \text{ cm}^2/\text{g}$, corresponding to a 70-KeV X ray (reference 2).

Tasks 2 and 3

The RAM on the east wall was positioned at the location where it would be permanently mounted. The beam was then moved from the horizontal aligned position into various misalignments, field sizes, and phantom sizes to evaluate the maximum scattering to the detector. The results are shown in Table 6.

Table 6. Survey Data of 19 June 1980

A. Misalignment maximum field; C-arm held at 255° rotation									
Swivel (head)	165	163	165	162	160				
Misalignment (°)	0	3	0	3	5				
RAM (mR/hr)	850	900	800	900	1K				
Thickness of phantom	8 inches/ 20.32 cm	8 inches/ 20.32 cm	1.75 inches/ 4.45 cm	1.75 inches/ 4.45 cm	1.75 inches/ 4.45 cm				
Distance from source to phantom (cm)	49	49	49	49	49				
B. Misalignment no phantom; C-arm held at 255° rotation									
Swivel (head)	162	160	157.5	154	155	155	147.5	150	149
Misalignment from horizontal (°)	3	5	7.5	6	10	10	17.5	15	16
Field size	Max	Max	Max	Max	Max	Min	Min	Min	Min
RAM (mR/hr)	800	900	2K	1K	1.5K	300	20K	800	4K
C. Optimization of RAM reading; C-arm held at 255° rotation									
Swivel (head)	155	149	149	162	155	165			
Misalignment from horizontal (°)	10	16	16	3	10	0			
Field size	Min	Min	Min	Max	Max	Max			
RAM (mR/hr)	200	1K	2.9K	1K	1.4K	850			
Thickness of phantom	8 inches/ 20.32 cm	8 inches/ 20.32 cm	1.75 inches/ 4.45 cm	4 inches/ 10.16 cm	4 inches/ 10.16 cm	4 inches/ 10.16 cm			
Distance from source to phantom (cm)	51.5	52	50	49	49	49			

Task 4

Penetration of radiation through the ceiling into occupied areas was evaluated by placing phantoms of various thicknesses as close to the beam as possible during irradiation. Note that each phantom was placed so that it encompassed the entire field (to maximize scatter) but with the minimum thickness directly above the field to reduce subsequent attenuation and secondary scatter of the initially scattered radiation.

Four surveys were made using phantoms with thicknesses of 1.75 inches/4.45 cm), 4 inches/10.16 cm, and 8 inches/20.32 cm. The 4-inch/10.16-cm phantom produced the maximum radiation levels, and was used twice. The data are summarized in the six parts of Figure 8. The data from each survey are plotted on a floor plan to show the actual scattering patterns. Figure 9 contains estimated isodose curves based on the maximum raw data.

All readings for the floor survey were made with a Ludlum detector with a sodium iodide crystal in counts per minute. A Thyac detector was also used in the survey. It gave consistently higher mR/hr values at the same location than did the Ludlum (as the Ludlum mR/hr-to-cpm conversion factor indicates). So all readings were converted to Thyac readings. This difference is not surprising because the Thyac and Ludlum have differing energy responses to the downscattered spectrum of photons exiting the floor, resulting in readings that do not match identically. Both instruments were maintained in routine calibrations. The conversion factor used to convert Ludlum to Thyac readings was

$$\frac{1.37 \times 10^{-6} \text{ mR/hr (Thyac)}}{\text{cpm (Ludlum)}}$$

Summary of 19 June 1980 Survey

A sheet of 0.25-inch/0.64-cm lead, placed over the pipe penetrations on the west wall, was found to be sufficient to eliminate the penetration problem. In addition, when the original alarm point of 10^3 R/hr was determined, no attempt was made to maximize the scatter toward the east wall.

It was discovered that some particular arrays could cause alarming. Reevaluation indicated that a set point of 1.4×10^3 R/hr was adequate to allow maximum scatter for maximum field experiment and yet to control a misaligned narrow beam. Scattering was also maximized through the second floor with a phantom 4 inches/10.16 cm thick. Dose estimates based on the maximized levels appear in the section on Summary Evaluation.

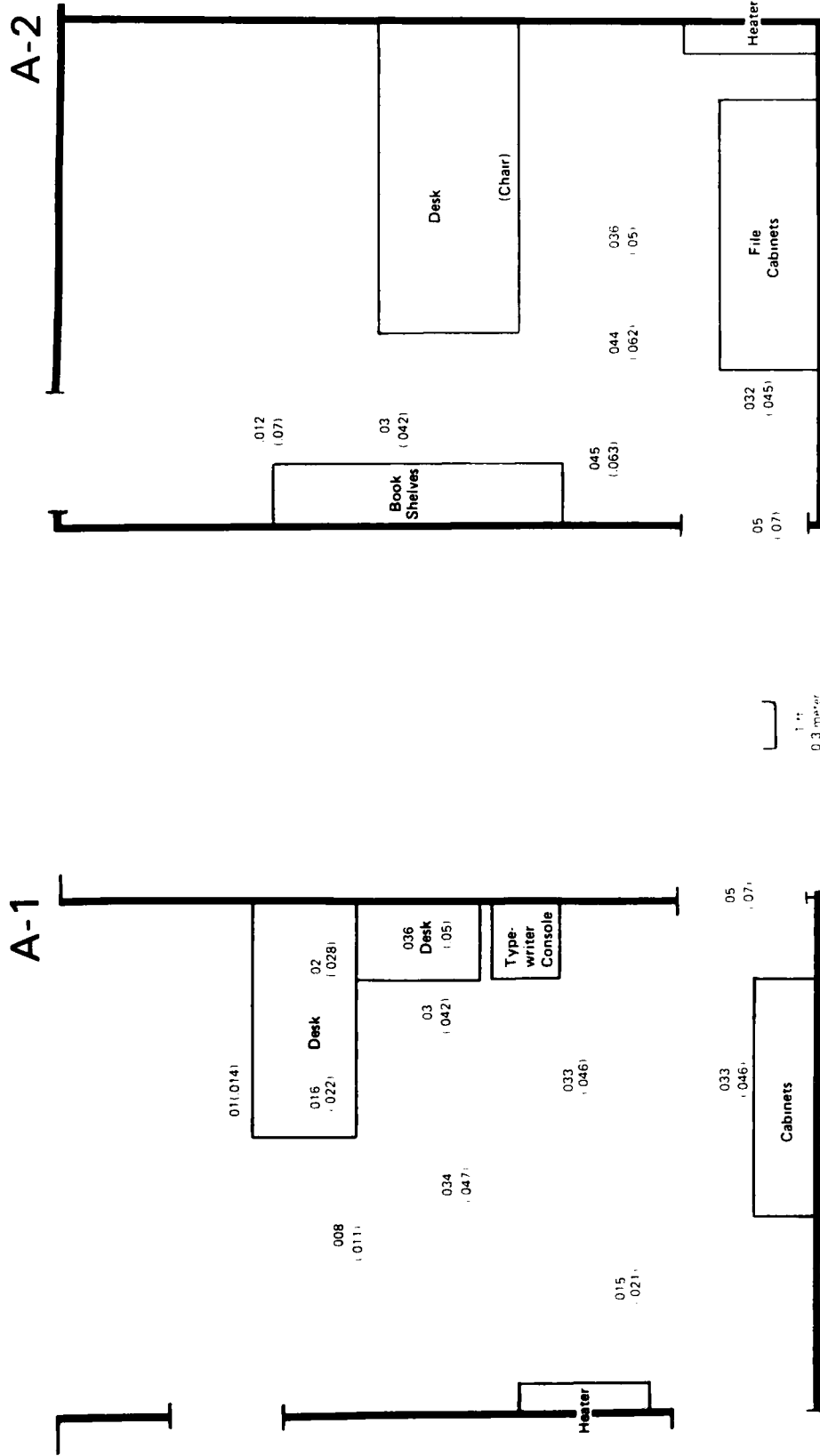

Figure 8 A. Two regions of penetration, identified as scattered radiation, each maximized by a phantom 1-3/8 inches thick and 49 cm from source. A-1: Room 2154. A-2: Room 2155. All readings in mR/hr. Pro-rated values in parentheses.

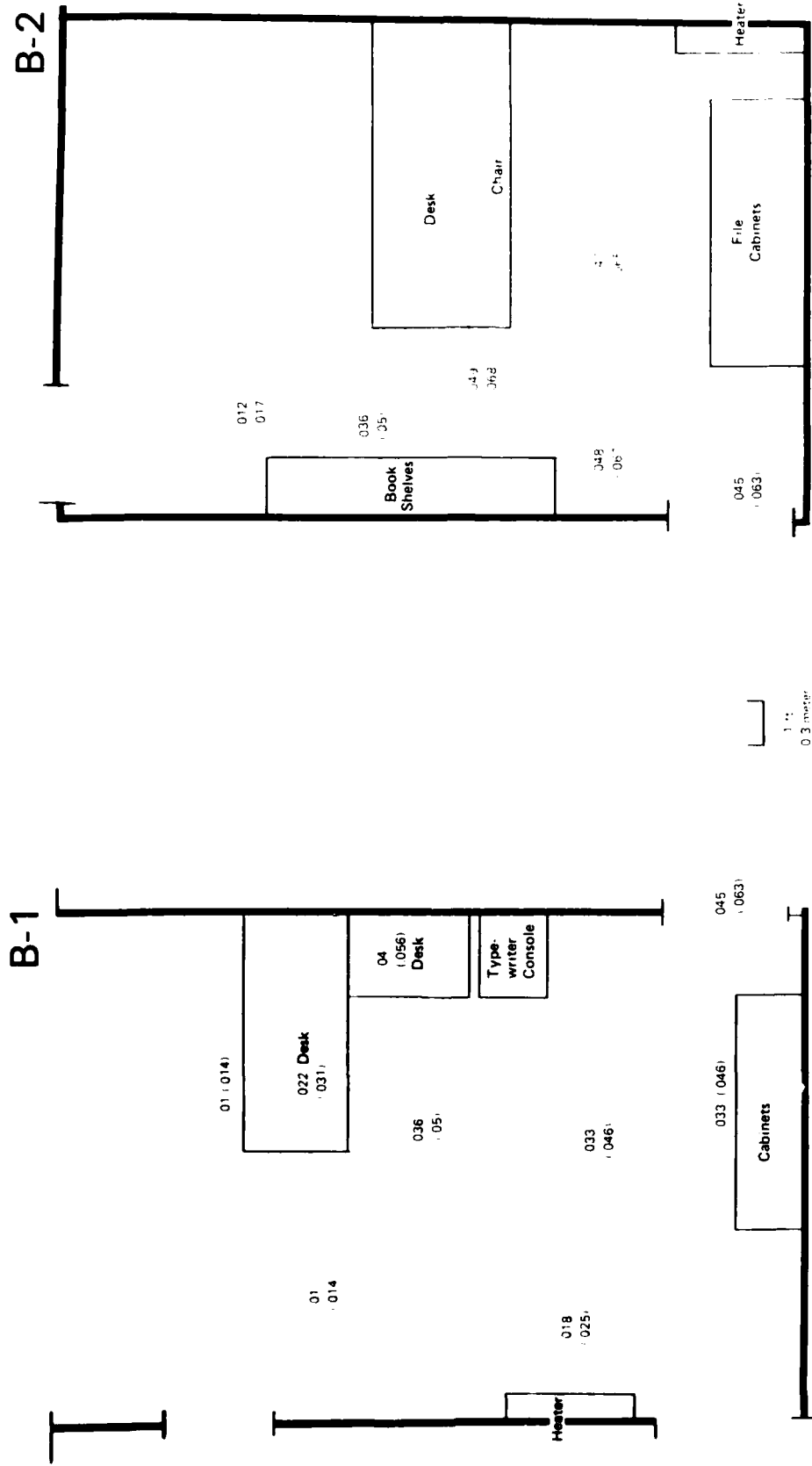

Figure 8 B. Two regions of penetration, identified as scattered radiation, each maximized by a phantom 8 inches thick and 49 cm from source. B-1: Room 2154. B-2: Room 2155. All readings in mR/hr. Pro-rated values in parentheses.

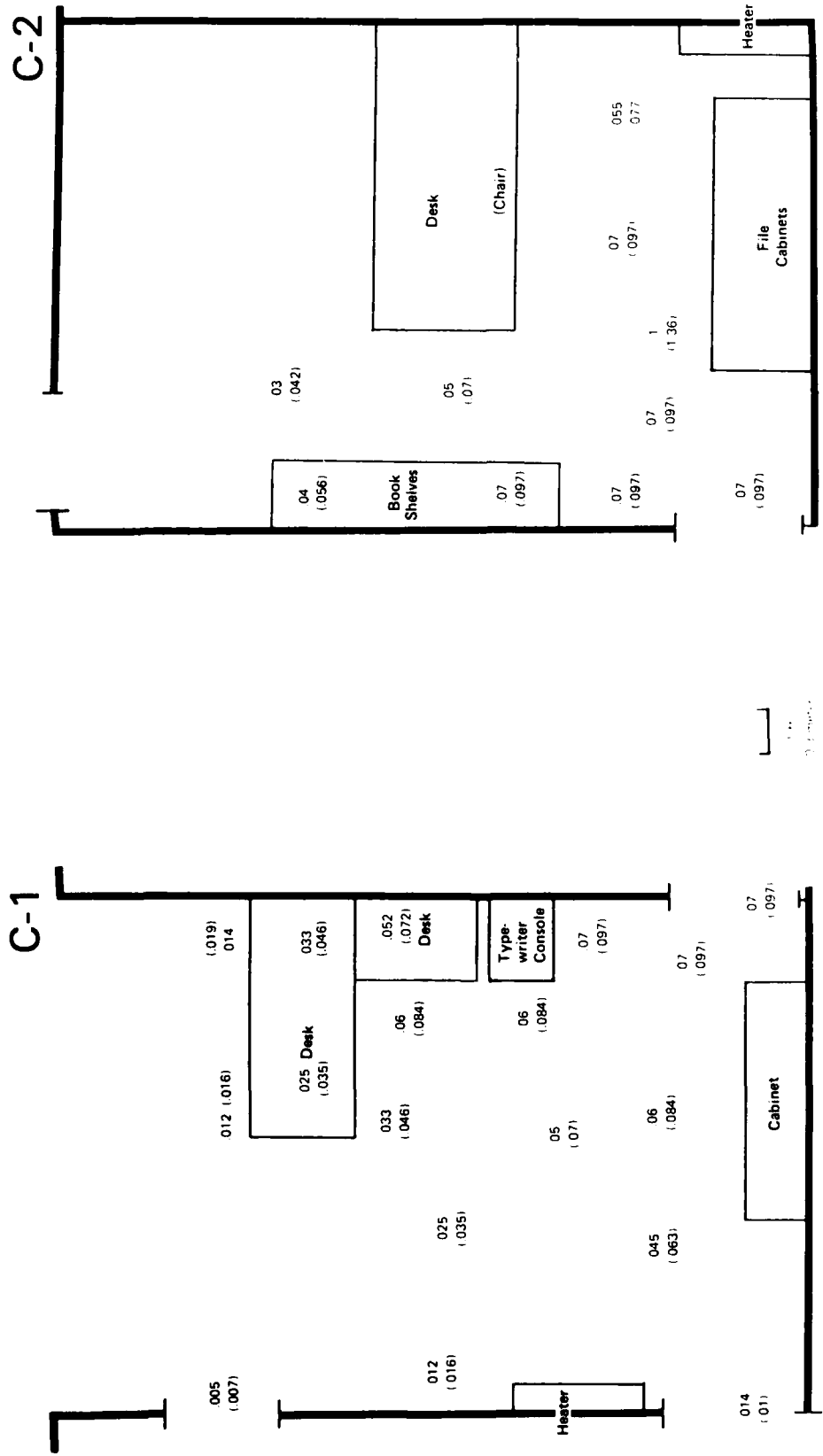

Figure 8 C. Two regions of penetration, identified as scattered radiation, each maximized by a phantom 4 inches thick and 49 cm from source. C-1: Room 2154. C-2: Room 2155. All readings in mR/hr. Pro-rated values in parentheses.

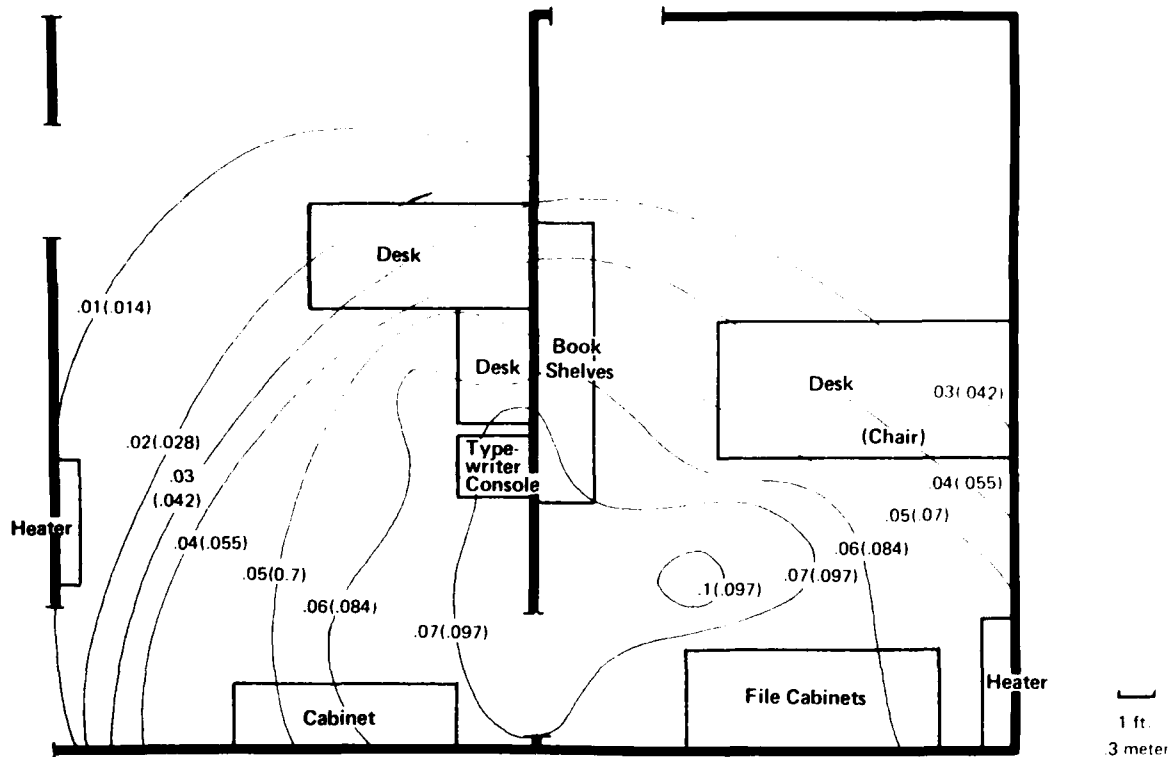

Figure 9. Summary of penetrations compiled in an isodose format. Isodoses estimated from observed penetrations. Four-inch phantom, 49 cm from source. All readings are in mR/hr. Pro-rated values in parentheses.

SUMMARY EVALUATION

The Theratron, with a rotational C-arm and swivel head, is capable of many irradiation configurations. The most probable modes of operation are (a) the C-arm vertical, source at top or bottom, and beam directed into beamstop; (b) C-arm horizontal and beam pointed away from Control Room into beamstop; (c) C-arm rotating and beam directed into beamstop to provide a 360° irradiation around the center of an object; (d) source head rotated to provide a projected beam parallel to the floor toward the east wall of the Standards Lab; (e) the skip mode; and (f) the preset mode. The Chairman of the Scientific Support Department of AFRRRI has submitted to the Reactor and Radiation Facility Safety Committee for authorization only the configurations of horizontal floor parallel projection and C-arm vertical with source at top, directed down. Only these two positions have been authorized by the Committee. All other modes are unauthorized for routine irradiation and will not be used without an additional safety review and Committee approval. Consequently, the identification of non-problem areas and personnel exposures are based on only these authorized operating modes.

The following areas are observed to have no evidence of radiation penetrations (see Figure 5 for zone references) at the level of measurement sensitivity in the surveys performed:

Photo labs (Zones E and F) on north wall of Standards Lab

West half of Director's office (Zone G), referred to as Room 2151 on blueprints

Hallway connecting stairwell and Rooms 2153, 2154, and 2155 (Zone K)

South wall exterior of Standards Lab (Zones M and N). (Note that this is valid for only the stated operational modes.)

The following regions pose no problems of radiation exposure for the noted operating conditions and precautions:

West wall exterior of Standards Lab, provided that 0.25 inch/0.64 cm of lead shielding remains on interior side of air duct penetrations (Zone 0)

Stairwell (Zone 0), provided that the wooden barrier remains in the closed position unless the freight door is open for access. This barrier simply prevents access to the low level sheet of streaming leakage at the face of the steel door.

In evaluating the exposure of personnel, a continuous 8-hour day and 5-day week for 52 weeks a year were found to be totally unrealistic in light of the following information:

1. The present AFRRRI cobalt unit, even with its high demand for use (due to its large dose rates and unique capabilities), operates for only 856 hr/yr (53% of total availability). This figure is based on the monthly cobalt utilization records for September 1979 through August 1980.

2. Also located in the Standards Lab is the cesium source (used for calibrating survey instruments) and the AFRRRI high-exposure-rate X-ray machine.

Since only one source in the Standards Lab can be operated at a time and since all sources must be shut off for maintenance and for most personnel entries, a yearly operating time of 856 hr/yr for the Theratron unit is considered the upper limit.

The following assumptions are used for estimates of personnel exposure:

Yearly total time of Theratron operation:	856 hr/yr
Full occupancy factor (see reference 2):	1
Partial occupancy factor (see reference 2):	1/4
Occasional occupancy factor:	1/16

CONTROL ROOM EXPOSURE

The highest reading obtained in the Control Room was at the door (closed) to the Prep Area. A value of 1.8 mR/hr (2.5) was received at the door center for a misaligned horizontal beam. The aligned value reduces this to 1 mR/hr (1.4). In all surveys, only positive readings above background were recorded, and no reading in the center of the room was observed to be greater than 0.1 mR/hr. For estimating personnel exposures, the following additional assumptions are made: Beam is aligned; operator occasionally leans against the Prep Area door (1/16 of time) and is in the center of the room during the remaining time (15/16 of time) (assume level of 0.1 mR/hr). It follows that

$$\begin{aligned} (0.1 \text{ mR/hr}) 856 \times 15/16 + 1 \text{ mR/hr} (856) 1/16 \\ = 80.25 + 53.5 = 134 \text{ mR/hr.} \end{aligned}$$

Note: When the shielding is added over the Prep Area, the value at the door should go to background. This reduces the estimated maximum exposure of the operator to approximately 80 mR/yr.

PERSONNEL EXPOSURE ROOM 2154 (Office of Secretary to Director)

Maximum level was observed on the floor near the door to Room 2155. At this point, a reading of 0.07 mR/hr (0.097) was obtained. The reading dropped to 0.06 mR/hr (0.084) on the floor in the area of the desk chair (see Figure 8). Assumptions: Secretary sits on floor to file, instead of in chair; occupancy factor is 1. Therefore $(0.06 \text{ mR/hr}) 856 = 51.4 \text{ mR/yr}$.

PERSONNEL EXPOSURE ROOM 2155 (Office of Educational
Program Coordinator)

A maximum localized level of 0.1 mR/hr (0.14) was observed near the corner of the file cabinets. In the area of the desk chair, the levels were approximately 0.055 mR/hr (.077) (see Figures 8 and 9). Assumption: Coordinator sits on floor sorting files, instead of in desk chair; occupancy factor is 1. The dose at desk chair is 47 mR/yr.

PERSONNEL EXPOSURES OUTSIDE EAST WALKWAY

At 3 ft/0.91 m above ground level at the corner of the side wall, a reading of 0.1 mR/hr (0.14) was recorded. Based on an occasional occupancy, the following exposure would result: $(0.1 \text{ mR/hr})(856)(1/16) = 5.4 \text{ mR/yr}$.

OPERATOR EXPOSURE—EMERGENCY SHUTDOWN

If the source were to stick open, the turnaround time for an emergency shutdown would be about 1 min, of which no more than 30 sec are spent at the source head. At the source head at chest level, the dose rate from 90° scattering is about $1.54 \times 10^4 \text{ mR/hr}$ (2.12×10^4). Assumption: Operator enters and stands at source head for 1 min. Therefore $(1.54 \times 10^4 \text{ mR/hr})(1/60 \text{ hr}) = 257 \text{ mR}$.

Particular recommendations based on the overall survey are made in Appendix B.

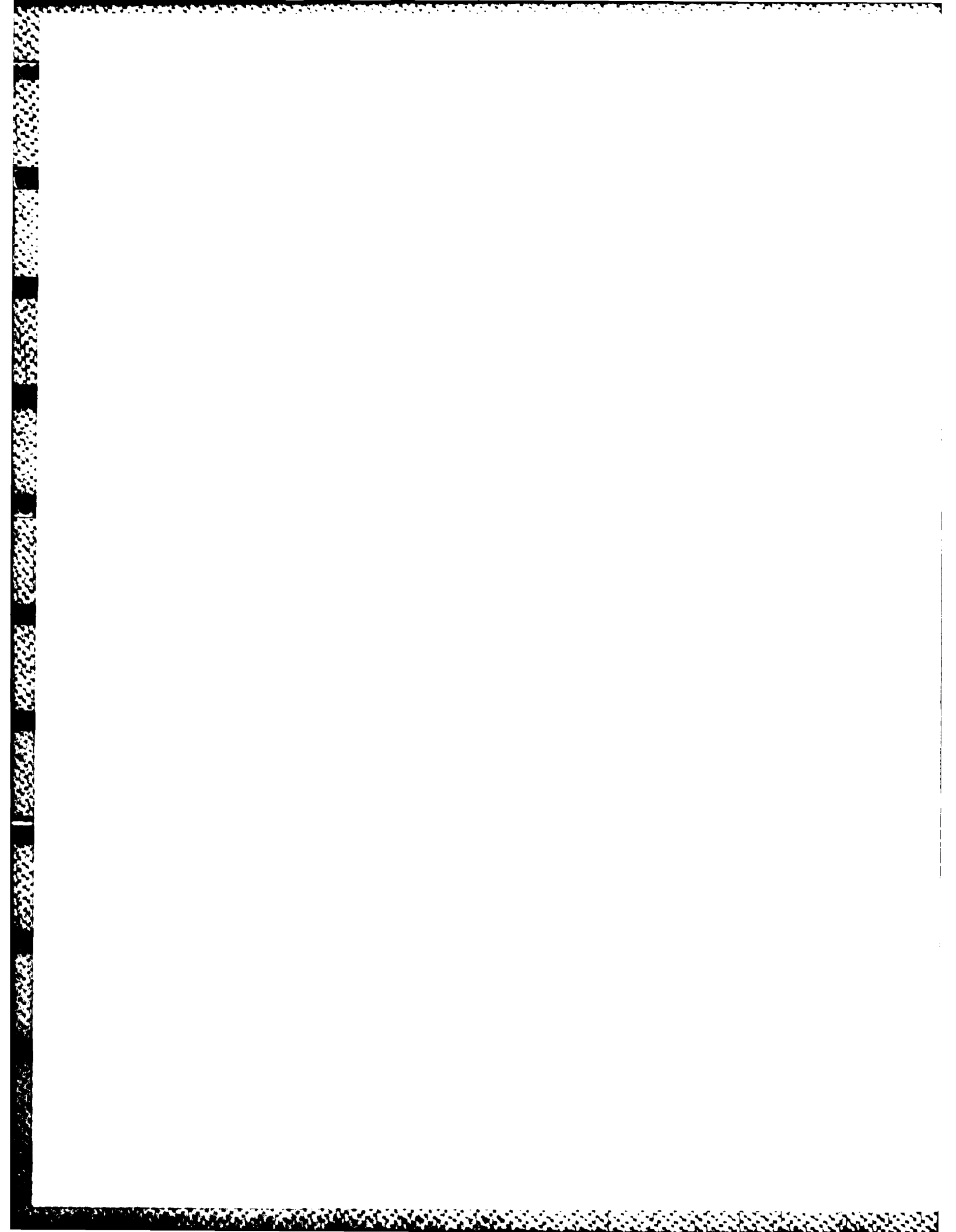

APPENDIX A. CALCULATIONS FOR SHIELDING OF
PREP AREA AND ROOMS 2154 AND 2155

PREP AREA

The purpose of shielding the Prep Area is to reduce the secondary scattered radiation to levels low enough to allow routine use of the room. Since there is no ceiling over the Area at present, a lead ceiling would substantially reduce the exposure here. However, the penetrations of scattered radiation through the 2-foot (.61 m) concrete wall separating the Prep Area from the Exposure Room have not been evaluated, due to the magnitude of the radiation from above.

Radiation on the Prep Area ceiling is scattered radiation, which undergoes a second scatter off the Standards Lab ceiling (Figure 10). If a conservative assumption is made that the radiation on the Prep Area "ceiling" (I_0) is of quality and intensity similar to the radiation on the Control Room ceiling, then the following equation is true:

$$\frac{\exp(-\mu_p x_p)}{I_{fp}} = \frac{\exp(-\mu_{pb} x_{pb} - \mu_c x_c)}{I_{fc}}$$

where x_{pb} is thickness of lead shielding on the Control Area (0.25 inch), x_c is thickness of concrete on Control Room ceiling (6 inches/5.08 cm), x_p is thickness of Prep Area ceiling, and the μ 's are the proper absorption coefficients. The I_f 's are the final intensities in the appropriate room. Calculating the thickness of the Prep Area ceiling that is necessary to reduce the final level to that of the Control Room ($I_{fp} = I_{fcr} = 0.1$ mR/hr), then

$$\mu_p x_p = \mu_{pb} x_{pb} + \mu_c x_c$$

The values x_{pb} and x_c are known. The values of μ_{pb} and μ_c can be found if the approximate energy of the incident photon is known. The incident radiation consists of primary cobalt-60 radiation that has undergone two Compton scatterings at the angles estimated in Figure 10.

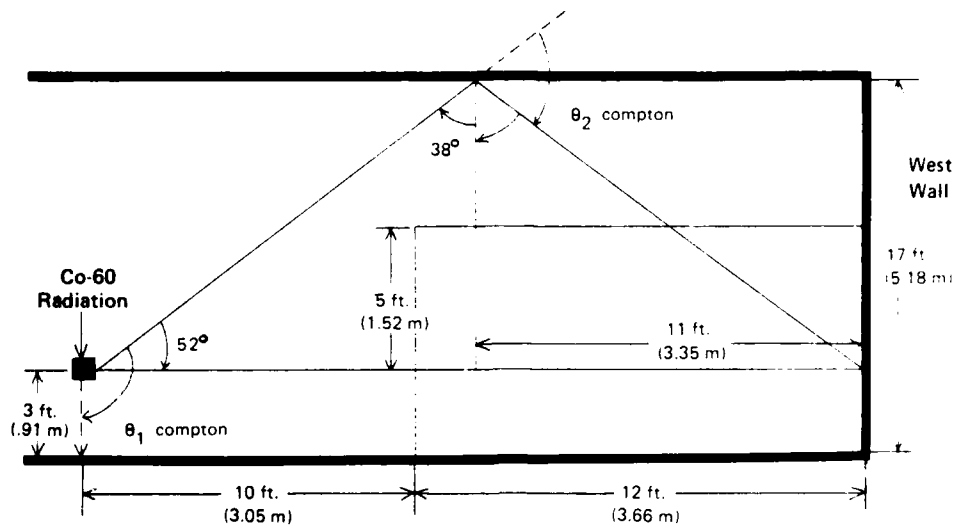

Figure 10. Geometric construction used in determining the estimated energy of scattered radiation entering Prep Area

The angles were chosen via the diagram in Figure 10 because, although photons from primary scatter of angles greater than θ_1 Compton would penetrate more in the center of the Prep Area, they are less energetic (greater θ_1 Compton) and consequently more easily absorbed. Similarly, although photons of angles less than θ_2 Compton are more energetic, fewer would penetrate into the Prep Area and a greater number would collide with the west wall. The scattered photons based on these angles and the following equation are listed below.

$$h\nu = \frac{m_0c^2}{1 - \cos\theta + m_0c^2}$$

$$m_0c^2 = 0.51 \text{ MeV}$$

First scatter: $\theta_1 = 142^\circ$, $h\nu_0 = 1.2 \text{ MeV}$, $h\nu = 0.23 \text{ MeV}$

Second scatter: $\theta_2 = 104^\circ$, $h\nu_0 = 0.23 \text{ MeV}$, $h\nu = 0.147 \text{ MeV}$

(Values are from reference 2, using 150-KVp X rays)

Six inches/0.15 m of concrete produces an attenuation of 5×10^{-3} ; an attenuation of 5×10^{-3} is equivalent to 1.35 mm of lead. Therefore, the total equivalent lead on the control room ceiling is 1.35 mm + 0.25 inch/0.64 cm or 7.7 mm (≈ 0.3 inch). Therefore, 0.375 inch/0.95 cm of lead will give the desired attenuation for the Prep Area ceiling. Because the Theratron is off the room centerline, the radiation scattered from the ceiling has a slightly shorter distance to travel to the Prep Area ceiling (approximately 17.8 ft/5.4 m) than to the Control Room ceiling (approximately 19.5 ft/5.9 m), which includes an additional horizontal 8 ft center to center. Therefore, an extra 0.125 inch/0.32 cm of lead is recommended.

These estimates assume that a survey will be conducted after installation of the lead.

ROOMS 2154 AND 2155

The ceiling of the Standards Lab consists of concrete reinforced with 2 ft/.61 m of steel. Radiation from the horizontal projection is 90° scattered radiation and forward scattered radiation from the phantoms. The final radiation that exists on the top side of the ceiling is a multi-scattered, built-up radiation, and most of it is less than 1.2 MeV. Knowing the approximate position of the source and approximate locations of the hottest spot in Rooms 2154 and 2155, one can estimate the scatter angle of the radiation causing the highest penetrations (see Figure 11). The localized "hot" spot in Room 2155 was about 4.5 ft/1.37 m from the east wall.

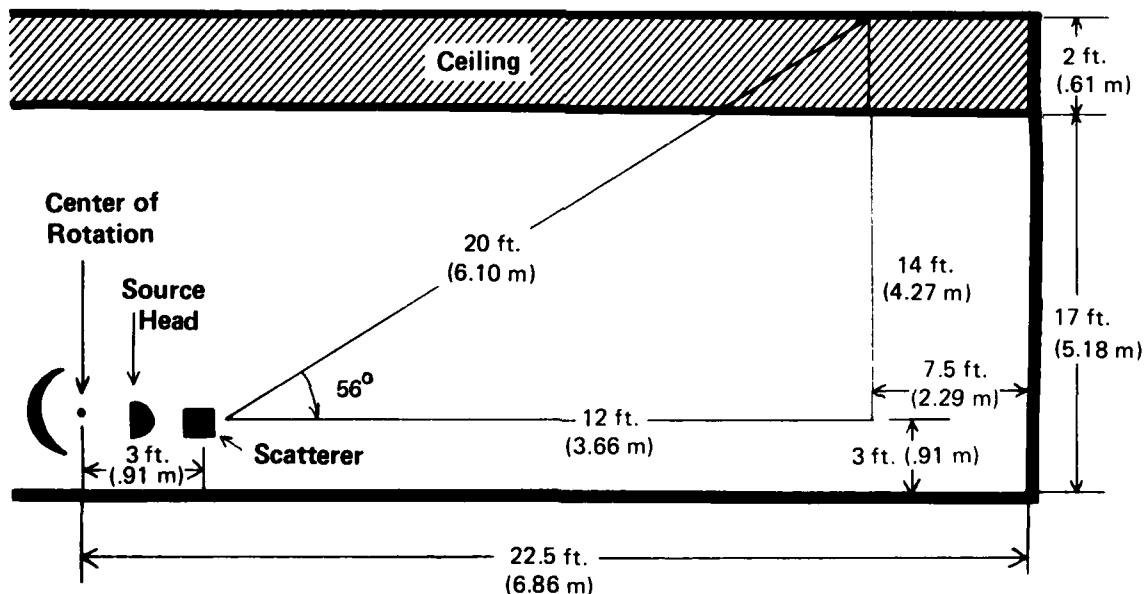

Figure 11. Geometric construction used in evaluating the attenuation provided by ceiling of Standards Lab for incident radiation at an oblique angle

Based on 60° scattered cobalt-60 radiation, a half-value layer of lead is 0.8 cm. Using a lead shield of 0.375 inch/0.95 cm, an attenuation factor of 0.4 of the existing exposure would be received.

Based on theoretical calculations, the actual attenuation factor presently being achieved can be estimated. (All input data are from reference 2.) At 1 m, $x = 3.8 \times 4 \times 10^3$ R/hr. A maximum field of 33 cm x 33 cm at 80 cm was used. Substituting into the following equation:

$$\dot{X}_{\text{exp}} = \frac{a\dot{X}}{(d_{\text{sec}})^2} \cdot \frac{1}{(d_{\text{sca}})^2} \cdot \frac{F}{400}$$

- \dot{X} = exposure rate at 1 m
- a = ratio of scatter to incident exposure at a given angle. An angle of 60° was chosen based on above geometry (therefore, $a = 0.0023$).
- d_{sec} = distance from scatter (20 ft = 6.1 m)
- d_{sca} = distance of scatter from source (0.5 m)
- F = field size at scatter in cm^2 (at 50 cm, field is 425.5 cm^2)

$$\dot{X}_{\text{exp}} = \frac{(0.0023) 3.814 \times 10^3}{6.1} \cdot \frac{1}{(0.5)^2} \cdot \frac{425.4}{400} = 1 \text{ R/hr}$$

Since actual measurements indicated an exposure rate of 0.1 mR/hr at the hot spot, the actual attenuation factor achieved is

$$\frac{0.1 \times 10^{-3} \text{ R/hr}}{1 \text{ R/hr}} = 1 \times 10^{-4}$$

APPENDIX B. RECOMMENDATION FOR THERATRON BASED ON
SURVEY OF SHIELDING

In accordance with observations from the survey, the following recommendations are made for routine use of the AFRRI Theratron.

- Since only two positions are authorized and since shielding analysis is based on these positions, it is recommended that a mechanical interlock be installed to allow only (a) the C-arm vertical, head on top, beam down, and (b) the horizontal beam parallel to the floor. This would prevent the beam's being placed in an unauthorized and unsurveyed position.
- Since maximum penetration into occupied areas would be in Rooms 2154 and 2155, it is recommended that a radiation detector (RAM or TLD) be placed near the doorway connecting these two offices. The detector should be placed as close to the floor as possible. If a particular experiment produced a radiation pattern above the patterns that occurred during simulations, then adequate indication would be given by this detector. An integrating dosimeter would be initially recommended.
- Any irradiation mode other than the two authorized must be preceded by a complete survey. Preliminary measurements indicate that an irradiation configuration is possible that would result in an increased localized penetration that does not exist in the authorized modes.
- In the Memo For Record of 22 July 1980, a RAM set point of 10^3 mR/hr was recommended for the east wall. If an interlock were installed to prevent gross misalignments on the order of 10^0 and if operations indicate the need, a higher alarm set point of up to ~1400 mR/hr would be safe. The main choice of a 10^3 -mR/hr alarm set point was based on the need to assure that the narrow beam will trigger the alarm before the beam is directed too far upward. This change in set point would allow future experimental arrays to produce a broader scattering pattern than initially evaluated.
- For the shielding of the Prep Area, 0.375 inch/0.95 cm is the minimum thickness of lead necessary for the ceiling. A thickness of 0.5 inch/1.27 cm is recommended. After placement of the shielding, the room should be resurveyed before routine use. The C-arm should be in the vertical position with the beam directed down. Bases for the recommended shielding appear in Appendix B. It is also recommended that the ceiling be designed to allow additional lead, if found necessary after the survey.

- At present, exposure of personnel in Rooms 2154 and 2155 is not a serious problem. Placement of 0.375 inch/0.95 cm lead on the south half of the floor would reduce the present exposure levels by 40% and also increase the margin of safety of the shielding in case of an unexpected problem.

ACKNOWLEDGMENTS

The author acknowledges the competent technical suggestions and review by John M. Arras and Lester A. Slaback, Jr. Assistance of the survey personnel identified in Table 1 is also greatly appreciated.

REFERENCES

1. Specification for the Theratron-80 automatic-type 1 teletherapy unit. Atomic Energy of Canada, Limited, Commercial Products, Ottawa, Canada.
2. Structural shielding design and evaluation for medical use of X-rays and gamma rays of energies up to 10 MeV. NCRP Report No. 49. National Council on Radiation Protection and Measurements, Bethesda, Maryland, September 15, 1976.

END

FILMED

3-84

DTIC