

UNCLASSIFIED

SECURITY CLASSIFICATION OF THIS PAGE (When Data Entered)

REPORT DOCUMENTATION PAGE		READ INSTRUCTIONS BEFORE COMPLETING FORM
1. REPORT NUMBER	2. GOVT ACCESSION NO.	3. RECIPIENT'S CATALOG NUMBER
NORDA Technical Note 183		
4. TITLE (and Subtitle) SHORT TERM MEASUREMENTS OF OMNIDIRECTIONAL AMBIENT NOISE		5. TYPE OF REPORT & PERIOD COVERED Final
		6. PERFORMING ORG. REPORT NUMBER
7. AUTHOR(s) G. B. Morris J. M. Berkson T. E. Stixrud		8. CONTRACT OR GRANT NUMBER(s)
9. PERFORMING ORGANIZATION NAME AND ADDRESS Naval Ocean Research and Development Activity National Space Technology Laboratories NSTL, Mississippi 39529		10. PROGRAM ELEMENT, PROJECT, TASK AREA & WORK UNIT NUMBERS PE63785N
11. CONTROLLING OFFICE NAME AND ADDRESS Naval Ocean Research and Development Activity National Space Technology Laboratories NSTL, Mississippi 39529		12. REPORT DATE July 1983
		13. NUMBER OF PAGES 44
14. MONITORING AGENCY NAME & ADDRESS (if different from Controlling Office)		15. SECURITY CLASS. (of this report) UNCLASSIFIED
		15a. DECLASSIFICATION/DOWNGRADING SCHEDULE
16. DISTRIBUTION STATEMENT (of this Report) Approved for public release, distribution unlimited.		
17. DISTRIBUTION STATEMENT (of the abstract entered in Block 20, if different from Report)		
18. SUPPLEMENTARY NOTES		
19. KEY WORDS (Continue on reverse side if necessary and identify by block number) ambient noise southwest Atlantic sonobuoys omnidirectional measurements		
20. ABSTRACT (Continue on reverse side if necessary and identify by block number) Short term omnidirectional measurements of ambient noise below 1 kHz were made for 14 deep-water stations in the Southwest Atlantic off the coast of South America during January 1981. At the lower frequencies (10 to 150 Hz) the noise levels agree with the middle range of the prediction curves for normal shipping densities in the northern oceans as reported by Wenz. No consistent major geographical or physiographic dependence of the mean noise levels was found for these reported measurements. The levels reported here for this South		

DD FORM 1473
1 JAN 73EDITION OF 1 NOV 65 IS OBSOLETE
S/N 0102-LF-014-6601

UNCLASSIFIED

SECURITY CLASSIFICATION OF THIS PAGE (When Data Entered)

Atlantic region are generally higher than those found for the South Pacific regions. This result was unexpected as the total shipping in the southern ocean basins is considerably less than that in the northern ocean basins. One possible explanation of why the noise levels are high is that sources from a high density shipping lane along the east coast of South America may have been more effectively coupled to the main propagation paths in the deep sound channel.

At the higher frequencies (200-1000 Hz) the noise levels exhibit the same wind speed dependence found in the northern oceans by Wenz and others and, in general, fall in the lower part of the noise levels reported.

Of the sonobuoys used, the unmodified SSQ-57A's consistently gave lower measures of ambient noise in the 10-150 Hz band than the other sonobuoys, and are considered to have suffered lower self-noise due to sensor motion or current flow around the hydrophones. The SSQ-57A (XN-5's) usually have to undergo hydrophone suspension modifications to achieve the same low levels as the unmodified SSQ-57A's in the low frequency band.

LIBRARY
RESEARCH REPORTS DIVISION
NAVAL POSTGRADUATE SCHOOL
MONTEREY, CALIFORNIA 93943

NORDA Technical Note 183

Naval Ocean Research and
Development Activity,
NSTL, Mississippi 39529



Short Term Measurements of Omnidirectional Ambient Noise in the Southwest Atlantic During January 1981

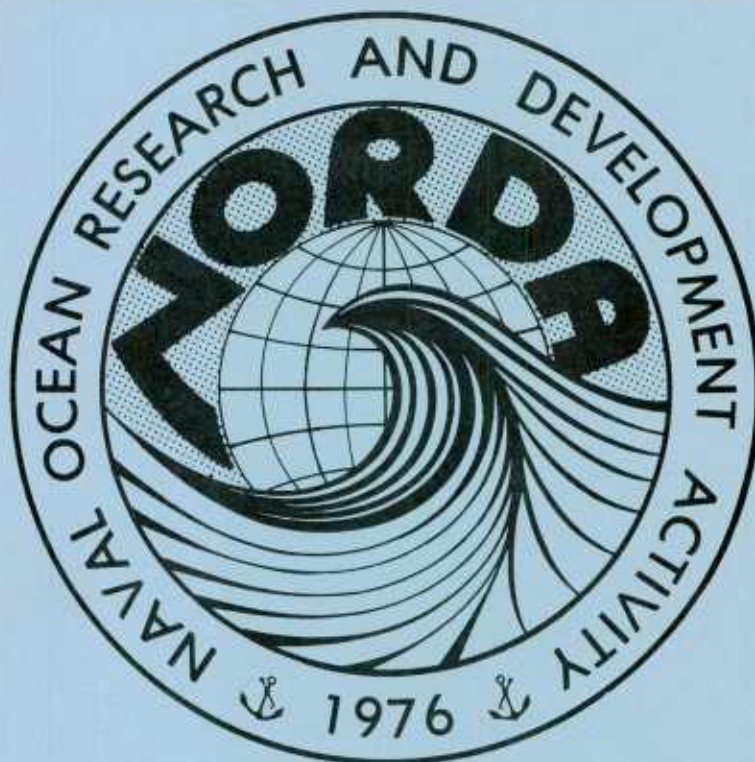

J.M. Berkson

G.B. Morris

Ocean Science and Technology Laboratory
Ocean Acoustics Division

T.E. Stixrud

Naval Ocean Systems Center
San Diego, California

Approved for Public Release
Distribution Unlimited

July 1983

ABSTRACT

Short-term omnidirectional measurements of ambient noise below 1 kHz were made for 14 deep-water stations in the Southwest Atlantic off the coast of South America during January 1981. At the lower frequencies (10 to 150 Hz) the noise levels agree with the middle range of the prediction curves for normal shipping densities in the northern oceans as reported by Wenz (1962). No consistent major geographical or physiographic dependence of the ambient noise levels was found for these reported measurements. The levels reported here for this South Atlantic region are generally higher than those found for the South Pacific regions. This result was unexpected as the total shipping in the southern ocean basins is considerably less than that in the northern ocean basins. One possible explanation of why the noise levels are high is that the sources from a high density shipping lane along the east coast of South America may have been effectively coupled to the main propagation paths in the deep sound channel.

At the higher frequencies (200-1000 Hz) the noise levels exhibit the same wind speed dependence found in the northern oceans by Wenz and others and, in general, fall in the lower part of the noise levels reported.

Of the sonobuoys used, the unmodified SSQ-57A's consistently gave lower measures of ambient noise in the 10-150 Hz band than the other sonobuoys, and are considered to have suffered lower self-noise due to sensor motion or current flow around the hydrophones. The SSQ-57A (XN-5's) usually have to undergo hydrophone suspension modifications to achieve the same low levels as the unmodified SSQ-57A's in the low frequency band.

ACKNOWLEDGEMENTS

The authors would like to thank our colleagues on the USNS HAYES for assistance in collecting data. We would like to thank M. Wilson for help in data processing; R. Denton and E. Tabor for assistance in programming; A. Monks and R. Barrett for assistance in calibrating the sonobuoy receiver, D. Fenner for calculating sound speed, D. Ramsdale and R. Wagstaff for helpful discussions about the manuscript. This effort was sponsored by the Surveillance Environmental Acoustic Support Project, NORDA Code 520, PE 63785N managed by R. R. Gardner.

INTRODUCTION

Low-frequency ambient noise measurements in the oceans are of interest because it is this background level against which various acoustic, sonar, and seismic systems must operate. While noise measurements have been made in a variety of areas, such measurements in the southern ocean areas are very sparse. Most data available have been taken in the South Pacific adjacent to Australia and New Zealand (e.g., Refs. 1 and 2); few measurements have been reported for the South Atlantic. In this report, we present omnidirectional measurements of ambient noise at 14 different locations in the southwestern Atlantic Ocean. These measurements were made during the austral summer season using sonobuoys deployed from a ship-of-opportunity that was transiting the region. The primary purpose was to determine the mean levels and variance and the first order geographical variability of the noise levels across the area. A secondary purpose was to test the standard and modified hydrophone suspensions of the sonobuoys to determine their applicability to such low frequency measurements.

These omnidirectional measurements of ambient noise were of short duration (typically one-half to one hour) and covered frequencies below 1 kHz. They were collected during January 1981 at the 14 moderate to deep water sites shown in Fig. 1 (also see Table I) in the South Atlantic during USNS HAYES Cruise No. 86-16-B. The stations were located in four major physiographic provinces, the western side of the Brazil Basin, the Bahia seamount province, the Rio Grande Rise, and the northwestern side of the Argentine Basin or Abyssal Plain. Two stations, 13 and 14, were on the extreme edge of the basin areas on the continental rise. In addition to these acoustic noise measurements, sound speed and surface wind velocity data were

obtained at each station. The sound speed profiles (Fig. 2) were calculated using Mackenzie's equation (Ref. 4) from XBT data collected at each acoustic station, plus historical salinity profiles, and then extended to bottom depth by using historical salinity and temperature data. Wind speed from the ship's anemometer is shown in Table I. The relationship between the ambient noise and these environmental parameters is discussed later.

MEASUREMENTS

At each location shown in Fig. 1, ambient noise measurements were made at two hydrophone depths, 300 ft and 1000 ft. At each station, four sonobuoys were launched for these noise measurements (Table II): one standard and one VLF-modified SSQ-57A (300 ft hydrophone depth) and one standard and one VLF-modified SSQ-57A (XN-5) (1000 ft hydrophone depth). For a typical station, the hydrophones were at depths lying below a shallow surface duct and well above the deep sound channel axis (Fig. 2). The suspension of the VLF-modified sonobuoys were designed to minimize the self-noise of the measuring system at low frequencies by isolating the hydrophone from the motion of the surface cannister caused by currents, winds, and surface waves. The modified buoys were similar to the very low frequency sonobuoy shown in Fig. 3 (Ref. 5).

To minimize contamination of the data by the signals radiated from the ship, the following procedure was used. After launching the sonobuoys, the ship continued about 6 nm along course before laying-to, shutting down the main engine generators. and stopping the use of noise-generating equipment

such as winches and bilge pumps. Measurements were then conducted with the ship quieted.

The signals received from the sonobuoy hydrophones were recorded for approximately one-half to one hour at each station. At each site, signals from at least two sonobuoys were recorded at two different gains, a high and a low gain state. These tapes were preserved and later processed in the laboratory to produce the spectral estimates and statistics of the ambient noise. The signals were band-pass filtered, 10-1000 Hz, and then digitized in 0.5 second time sections at a sampling rate of 2048 Hz. A 1024-point discrete Fourier transform using a Hann window was taken to obtain a spectra with approximately 3 Hz resolution over the 10-1000 Hz band. Fifty such 0.5 second sections were processed and averaged to produce a decibel-smoothed spectral estimate. Sixteen such spectra were averaged over approximately a 25-minute interval to produce the final averaged noise level spectrum and the standard deviation of the noise (See Appendix I for greater detail).

RESULTS

The 3 Hz resolution ambient noise spectral levels and standard deviations for standard SSQ-57A (300 ft) and standard SSQ-57A (XN-5) (1000 ft) measurement systems at each of the 14 South Atlantic stations are shown in Fig. 4. The upper curves for each station represent the ensemble-averaged ambient noise levels and the lower curves represent standard deviations. At frequencies above 100 Hz ambient noise levels of the different sonobuoys at a given acoustic station are similar; at lower frequencies there are large

differences. For 12 of the 13 comparisons of Fig. 4, the low-frequency levels for the standard SSQ-57A (300 ft) are much lower than the SSQ-57A (XN-5) (1000 ft). This is a result of the higher self-noise in the SSQ-57A (XN-5) (1000 ft) sonobuoy.

The self-noise of the SSQ-57A(XN-5) sonobuoy is significantly reduced by the VLF modifications to the hydrophone system, as shown in Fig. 5. Here the VLF-modified SSQ-57A (XN-5) (1000 ft) ambient noise levels at low frequency are similar to the SSQ-57A (300 ft), which has an excellent hydrophone suspension system. In fact, comparison of the standard and VLF-modified SSQ-57A (300 ft) indicates that the modifications do not further reduce the low-frequency self-noise of the system.

The sound velocity profiles shown in Fig. 2 reveal that the 300 ft hydrophones are well below the sonic layer depth. As both hydrophone depths lie within the deep-sound channel, we would therefore expect low-frequency ambient noise levels at 300 ft and 1000 ft to be similar. Thus, we will use primarily the results of the standard SSQ-57A (300 ft) for the low-frequency ambient noise levels, and we will use both the standard SSQ-57A (300 ft) and the standard SSQ-57A (XN-5) (1000 ft) for the high frequencies. Since the type of VLF modifications varied with the stations and had varying degrees of success, we have chosen not to use the VLF sonobuoy results for the regional analysis because of the non-uniform response from station to station.

Low-Frequency

The low-frequency part of the ambient noise spectrum from about 10 to 150 Hz is generally a function of the effects of distant shipping and the

environmental conditions for acoustic propagation. Passage of a nearby ship is easily capable of adding additional noise and distorting the spectrum for an acoustic station. Radar and visual observations of shipping by the USNS HAYES during the ten day measurement period identified only one surface ship. This occurred at station 6. Note that the noise spectrum for station 6 (Fig. 4F) clearly shows blade lines in the 10-100 Hz band. The noise spectrum at station 7 (Fig. 4G) also exhibits blade-line harmonics at the low frequencies, suggesting that although not visible on radar, a ship was sufficiently close to affect the acoustic measurements.

Figure 6 shows a superposition of the mean ambient noise levels for all 14 stations as measured using the unmodified 300 ft hydrophone depth sonobuoys. Also included are the deep-water ambient noise curves of Wenz (Ref. 6). These South Atlantic data show noise levels comparable to Wenz's "usual deep water traffic noise" curve for frequencies above about 20 Hz. Note that station 6, which showed the effects of a nearby ship, exhibits noise levels higher than that measured at the other stations. These South Atlantic noise levels are also in general agreement with Cato's results (Ref. 1) for the Tasman Sea where observations were made close to the Australian coast within about 10 nautical miles of the coastal shipping lane.

Figure 7, which displays shipping densities for this region, shows that these acoustic stations are located within a few hundred miles of a major shipping lane along the east coast of South America. To examine the effect which the proximity of the measurement station to the coastal shipping has on the ambient noise, the measured levels for four low frequency bands were plotted as a function of distance from this shipping lane in Fig. 8. Note that for an infinite line of sources in a waveguide, as discussed by Weston

(Ref. 7), one would expect to see little change in the resulting noise levels with increased range from the line of sources. The 100 Hz and 200 Hz data show this independence of range in Fig. 8, but not the 25 Hz and 50 Hz data where we would expect the shipping noise to be the most dominant. The noise at 25 Hz and 50 Hz shows a slight increase in level with increasing range out to about 150 nautical miles. Beyond this range the levels decrease rapidly.

We can offer no solid evidence to explain this behavior exhibited by the lower frequency data in Fig. 8 other than to postulate that there is some other environmental factor which causes this variability. Certainly other factors, such as the incompleteness of the wave guide, the finite rather than the infinite line of sources, and the bathymetric complexities along the continental margins over which much of the coastal shipping takes place, may contribute to this effect.

The sound speed profiles of Fig. 2 show that at all 14 stations the propagation is bottom-limited; i.e., the critical depth is deeper than the water depth. The depth difference (critical depth minus water depth) varies from about 180 to 2400 meters. In such areas, interaction with the sea floor can strip sound propagating from distant shipping, resulting in lower ambient noise levels. An indication of this effect is observed for frequencies 25 Hz and 50 Hz in Fig. 9, which suggests that the ambient noise tends to decrease slightly with increasing depth difference.

The acoustic stations occur in several different physiographic provinces: abyssal plain, edge of abyssal plain, sea mount, continental rise, and Rio Grande Rise. These physiographic provinces were delineated on the basis of bathymetry (Refs. 3, 8, 9), sediment grain size, and carbonate content data

(Ref. 8). Fig. 10 shows no apparent relationship between the physiographic province of the acoustic station and the ambient noise level. Nor does there appear to be any apparent, simple relationship between ambient noise level and geographic latitude (Fig. 11) or water depth (Fig. 12).

High Frequency

The ambient noise spectrum above about 200 Hz is generally wind dependent (Ref. 6). During the acoustic measurements, the wind speed (Table I) varied from near calm to 20 knots. The log wind speed dependence of spectrum levels of ambient noise at seven frequencies for the standard SSQ-57A (300 ft) is shown in Fig. 13. The ambient noise levels at the higher frequencies exhibit strong wind dependence. The correlation coefficient between ambient noise level and log wind speed (Table III) are higher for these high frequencies. The low correlations of the low-frequency data indicate no wind dependence and also successful isolation of the measurement from wind induced self-noise, except at 50 Hz. The ambient noise levels are consistent with values reported in the literature (Ref. 6, 10-12) and fall at the lower part of the range of the reported values for the wind-dependent part of the spectrum.

CONCLUSION

Measurements of short-term omnidirectional ambient noise in the frequency band from 10-1000 Hz were made for 14 stations in the Southwest Atlantic off the coast of South America during January 1981. At the lower frequencies (10

to 150 Hz) the noise levels agree with the middle range of the prediction curves for normal shipping densities in the northern oceans as reported by Wenz (Ref. 6). No consistent major geographical or physiographic dependence of the mean noise levels was found for these reported measurements. There was a slight indication that the depth difference between the local critical depth and bottom depth, a measure of the severity of the local bottom-limited acoustic propagation, influenced the ambient noise levels. The stations with more severely bottom limited propagation also exhibited lower mean ambient noise levels.

The levels reported here for this South Atlantic region are generally higher than those found for the South Pacific regions as reported by Cato (Ref. 1). These higher levels reported here for the South Atlantic were unexpected as the total shipping in the southern ocean basins is considerably less than that in the northern ocean basins. If the ambient noise due to the ships is the integration of the effects of all the sources, then one would expect the noise levels in the southern oceans to be less, on the average, than the levels in the northern ocean basins. Although no measurements of long range transmission loss were made at the time of these noise measurements, we have no reasons to suspect the acoustic propagation conditions were extraordinarily favorable. In general, the propagation conditions should be relatively poor, as most of the region was severely bottom limited for surface source propagation. Moreover, we have no reasons to suspect that the source levels for these surface ships were anomalously high. One possible explanation of why the noise levels are so high is that the sources may have been more effectively coupled to the main propagation paths in the deep sound channel. It can be noted that the high ship density regions delineated in Fig. 7 lie almost directly over the 1000 fathom contour

along the east coast of South America shown in Fig. 1. Others have observed that the radiated noise from ships over such continental slopes couples effectively to the major refracted and RSR paths, an effect referred to as "slope enhancement" (Ref. 13). Such a line of sources located colinearly above the continental slope would appear to be anomalously strong due to this more effective coupling.

At the higher frequencies (200-1000 Hz) the noise levels exhibit the same wind speed dependence found in the northern oceans by Wenz (Ref. 6) and others (Refs. 10-12) and in general fall in the lower part of the noise levels reported.

While more data are required to test the hypothesized "slope enhancement" effect and to establish the ambient noise patterns for such a region, the reported measurements provide an estimate of the first order mean levels and variability of ambient noise in deep water for this region during the austral summer.

Of the sonobuoys used, the unmodified SSQ-57A's consistently gave lower measures of ambient noise in the 10-150 Hz band than the other sonobuoys, and are considered to have suffered lower self-noise due to sensor motion or current flow around the hydrophones. The SSQ-57A (XN-5's) usually have to undergo hydrophone suspension modifications to achieve the same low levels as the unmodified SSQ-57A's in the low-frequency band.

REFERENCES

1. D. H. Cato, 1976, Ambient sea noise in waters near Australia, *J. Acoust. Soc. Am.*, 60, p. 320-328.
2. R. W. Bannister, R. N. Denham, K. M. Guthrie, D. G. Browning, and A. J. Perronne, 1979, Variability of low-frequency ambient sea noise, *J. Acoust. Soc. Am.*, 65, p. 1156-1163.
3. P. R. Supko, K. Perch-Nielson, and R. L. Carlson, 1977, Introduction and explanatory notes, Leg 39, Deep Sea Drilling Project, Initial Reports of the Deep Sea Drilling Project, Vol. 39, Washington, DC, U.S. Government Printing Office, p. 5-24.
4. K. V. Mackenzie, 1981, Nine-term equation for sound speed in the oceans, *J. Acoust. Soc. Am.*, 70, p. 807-12.
5. T. E. Stixrud, 1979, Very low frequency sonobuoy, U.S. Patent 4,161,716, reviewed in *J. Acoust. Soc. Am.*, 67, 1980, p. 364.
6. G. M. Wenz, 1962, Acoustic ambient noise in the ocean spectra and sources, *J. Acoust. Soc. Am.*, 34, p. 1936-56.
7. D. E. Weston, 1980, Ambient noise depth-dependence models and their relation to low-frequency attenuation, *J. Acoust. Soc. Am.*, 67, p. 530-537.
8. Anonymous, 1969, Atlantic Ocean Atlas, USSR.
9. Naval Oceanographic Office, 1978, Naval Oceanographic Office South Atlantic Ocean Chart, SA-1, SA-3, and SA3A/Sp-6A.
10. W. W. Crouch and P. J. Burt, 1972, The logarithmic dependence of surface-generated ambient-sea-noise spectrum level on wind speed, *J. Acoust. Soc. Am.*, 51, p. 1066-72.
11. G. B. Morris, 1978, Depth dependence of ambient noise in the Northeastern Pacific Ocean, *J. Acoust. Soc. Am.*, 64, p. 581-90.
12. J. A. Shooter and M. L. Gentry, 1981, Wind generated noise in the Parece Vela Basin, *J. Acoust. Soc. Am.*, 70, p. 1757-1761.
13. G. B. Morris, 1975, Preliminary results on seamount and continental slope reflection enhancement of shipping noise, SIO Reference 75-34, Scripps Institution of Oceanography, San Diego.
14. R. B. Blackman and J. W. Tukey, 1958, *The Measurement of Power Spectra*, Dover Publications, Inc., NY.

TABLE I

AMBIENT NOISE STATIONS

<u>Station #</u>	<u>Latitude (S)</u>	<u>Longitude (W)</u>	<u>Date (1/81)</u>	<u>Time (Z)</u>	<u>Wind Speed (KTS)</u>	<u>Water Depth (m)</u>
1	11°45.6'	32°45.6'	18	0832	15	2653
2	13°27.8'	31°49.0'	18	1944	12	4899
3	15°38.2'	30°36.3'	19	0837	13	4817
4	19°15.0'	31°59.9'	20	0442	5	4178
5	21°36.4'	32°56.0'	20	1734	5	4382
6	23°48.5'	34°01.9'	21	0636	12	4483
7	25°58.9'	35°03.1'	21	1906	18	4240
8	27°53.1'	35°55.6'	22	0619	14	4409
9	29°40.1'	37°42.5'	22	2147	18	4083
10	31°12.7'	39°29.4'	23	1248	15	4246
11	32°50.0'	41°17.7'	24	0342	6	4494
12	33°47.0'	45°23.0'	24	2258	15	4225
13	34°30.5'	49°24.1'	25	1708	18	3557
14	35°12.6'	50°47.0'	26	0407	16	3123

TABLE II. Type of sonobuoy used for acoustic measurements at each station

STATION	NUMBER OF EACH TYPE SONOBUOY OPERATED			
	STANDARD SSQ-57A (300 ft)	STANDARD SSQ-57A (XN-5) (1000 ft)	VLF MODIFIED SSQ-57A (300 ft)	VLF MODIFIED SSQ-57A (XN-5) (1000 ft)
1	1	1	1	1
2	1	1	1	1
3	1	1	0	1
4	1	1	1	0
5	1	0	1	1
6	1	1	1	1
7	1	1	0	1
8	1	1	1	0
9	1	1	1	1
10	1	1	1	0
11	1	1	1	0
12	1	1	0	2
13	1	1	1	1
14	1	1	0	2

TABLE III. Correlation coefficients of the regression lines relating ambient noise spectral levels to wind speed (see Fig. 14)

<u>FREQUENCY (HZ)</u>	<u>CORRELATION COEFFICIENT</u>
25	0.09
50	0.28
100	0.00
200	0.33
250	0.62
500	0.80
1000	0.84

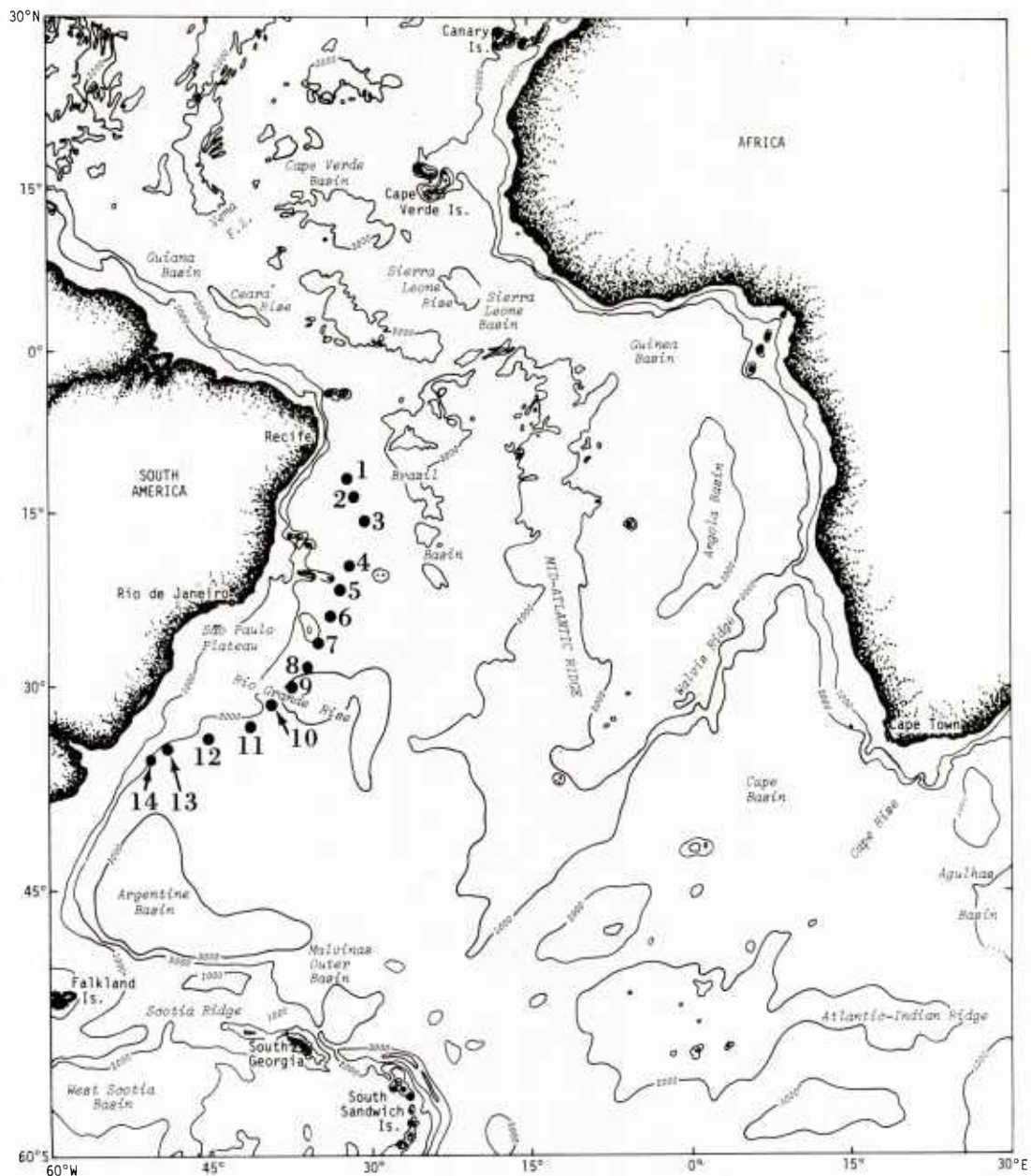

Figure 1. Location of ambient noise measurement stations. Chart after Ref. 3. Contours are in fathoms. Latitude and longitude of each station are given in Table I.

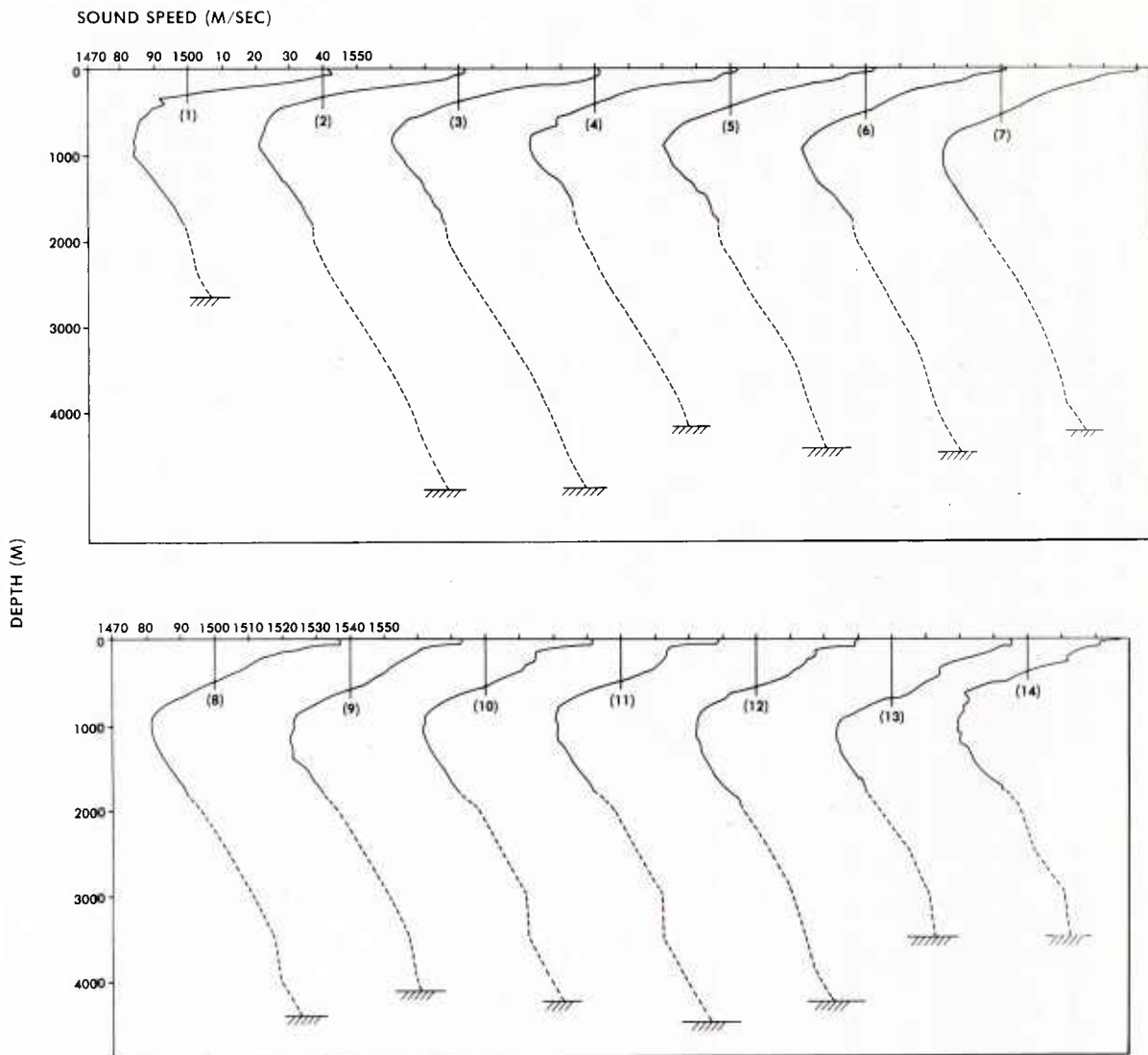

Figure 2. Sound speed profile for each of the 14 ambient noise stations. Solid line indicates sound speed profile calculated from XBT data collected during each ambient noise station and historical salinity data using Mackenzie's equation (Ref. 4). Dashed line indicates extrapolation of profile to the bottom depth based on historical data. Note that all of the locations are bottom-limited.

12 - CONTAINER
 12A - PERFORATED
 BULKHEAD
 13 - RADIO TRANSMITTER
 BUOY

14A - FLOATS
 16 - CABLE
 17 - CABLE
 18 - FLOAT
 19 - CABLE
 20 - HYDROPHONE

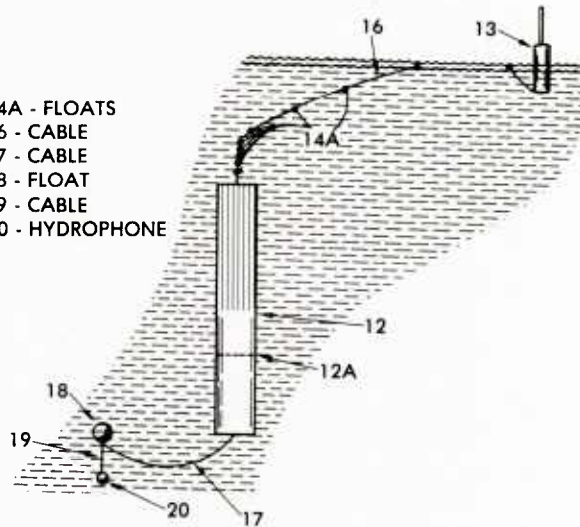

Figure 3. Very Low Frequency Sonobuoy (Ref. 5). The suspension of the VLF sonobuoy is designed to isolate the hydrophone from the effects of current, wind, and surface waves. During the experiment, several variations of this basic design were used to modify SSQ-57A (300 ft) and SSQ-57A (XN-5) (1000 ft) sonobuoys.

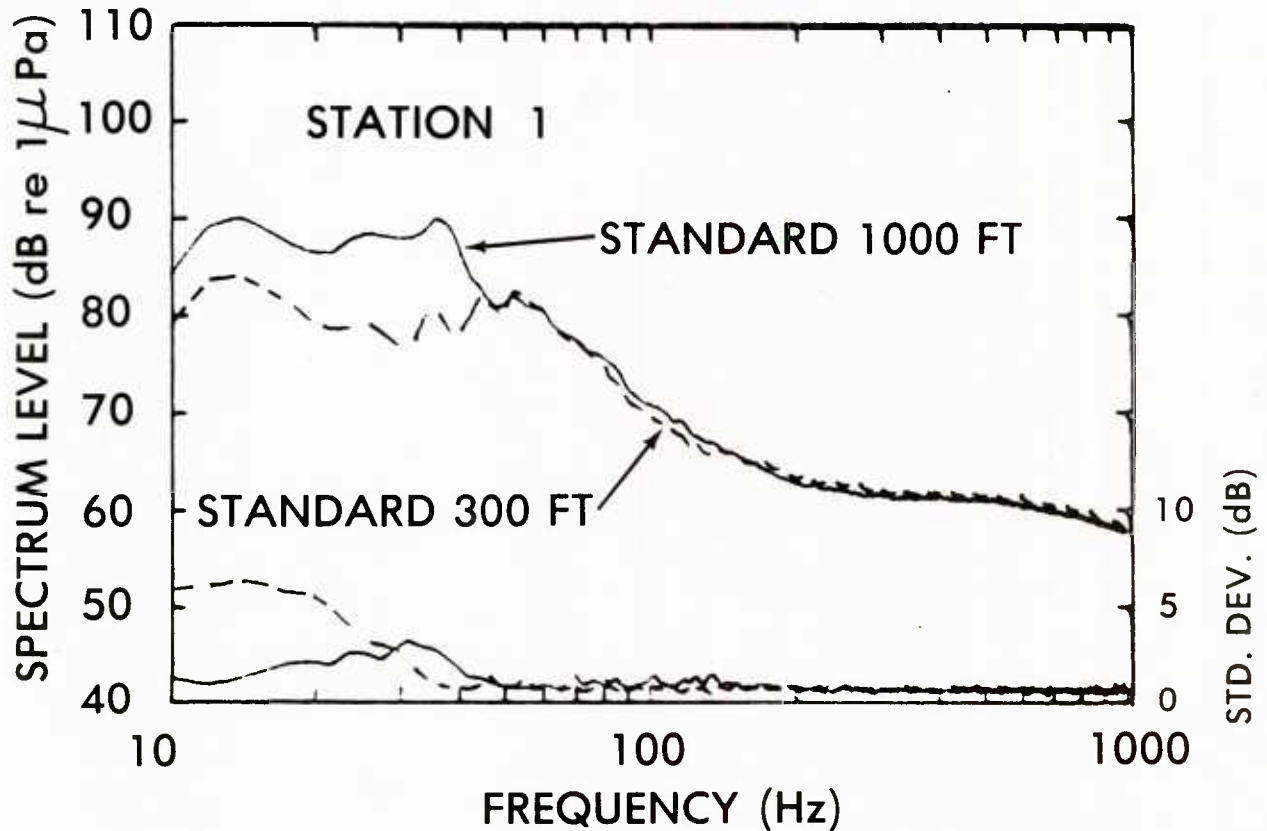

Figure 4A. Ambient noise spectral values from standard sonobuoys at Station 1. Upper curves for each acoustic station represent the 2-Hz ambient noise levels from standard SSQ-57A (300 ft) and standard SSQ-57A (XN-5) (1000 ft) sonobuoys. The lower curves represent the respective standard deviations (scale shown at right). Solid line, 1000 ft; dashed line, 300 ft. The increased values of noise of the 1000 ft buoys below 100 Hz are due to increased self-noise of the measuring system.

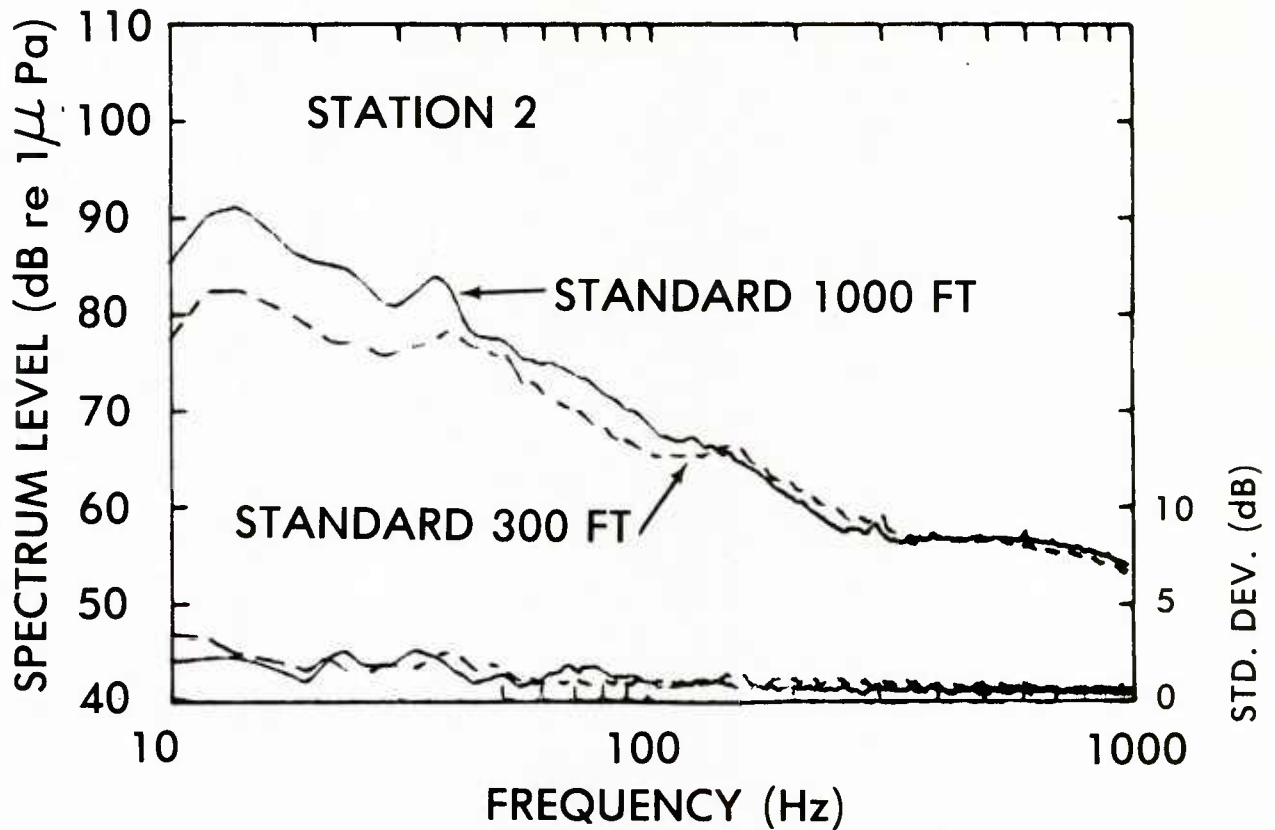

Figure 4B. Ambient noise spectral values from standard sonobuoys at Station 2. Upper curves for each acoustic station represent the 2-Hz ambient noise levels from standard SSQ-57A (300 ft) and standard SSQ-57A (XN-5) (1000 ft) sonobuoys. The lower curves represent the respective standard deviations (scale shown at right). Solid line, 1000 ft; dashed line, 300 ft. The increased values of noise of the 1000 ft buoys below 100 Hz are due to increased self-noise of the measuring system.

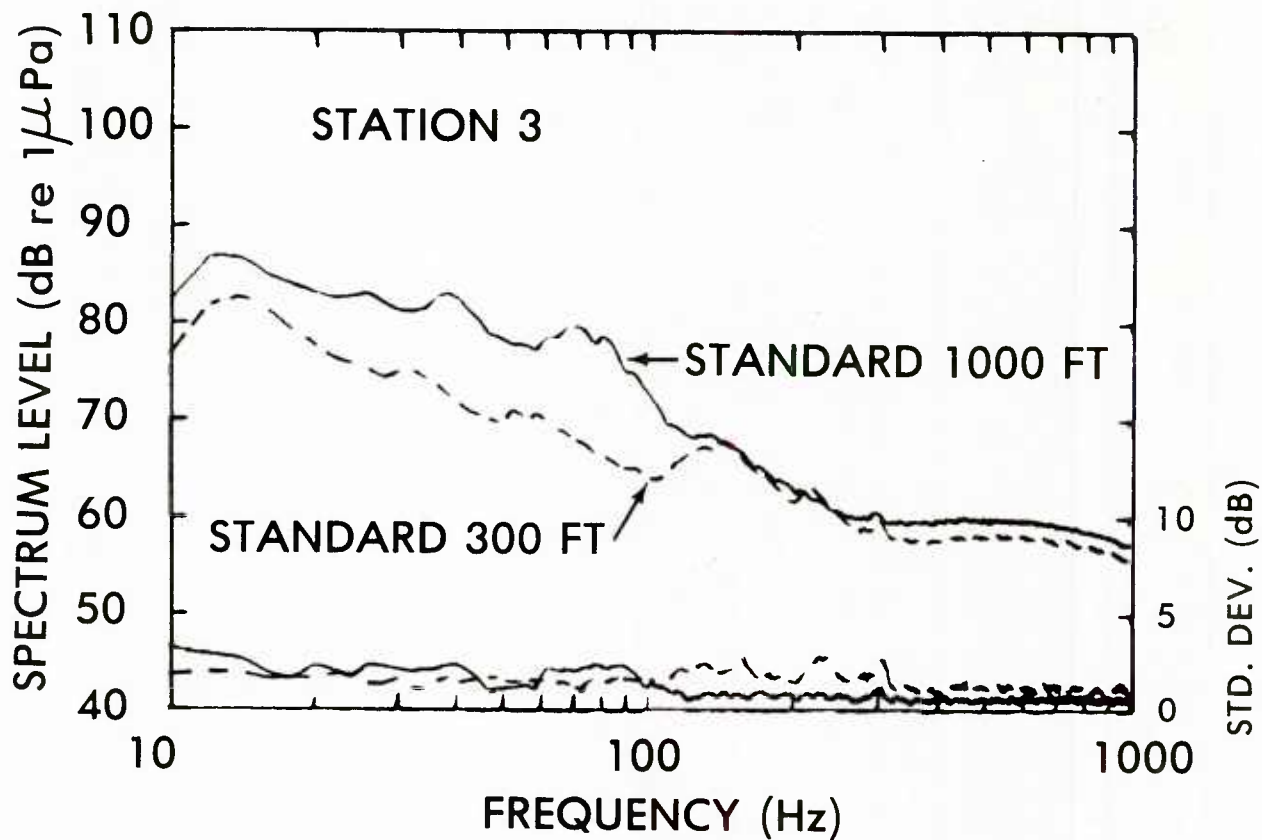

Figure 4C. Ambient noise spectral values from standard sonobuoys at Station 3. Upper curves for each acoustic station represent the 2-Hz ambient noise levels from standard SSQ-57A (300 ft) and standard SSQ-57A (XN-5) (1000 ft) sonobuoys. The lower curves represent the respective standard deviations (scale shown at right). Solid line, 1000 ft; dashed line, 300 ft. The increased values of noise of the 1000 ft buoys below 100 Hz are due to increased self-noise of the measuring system.

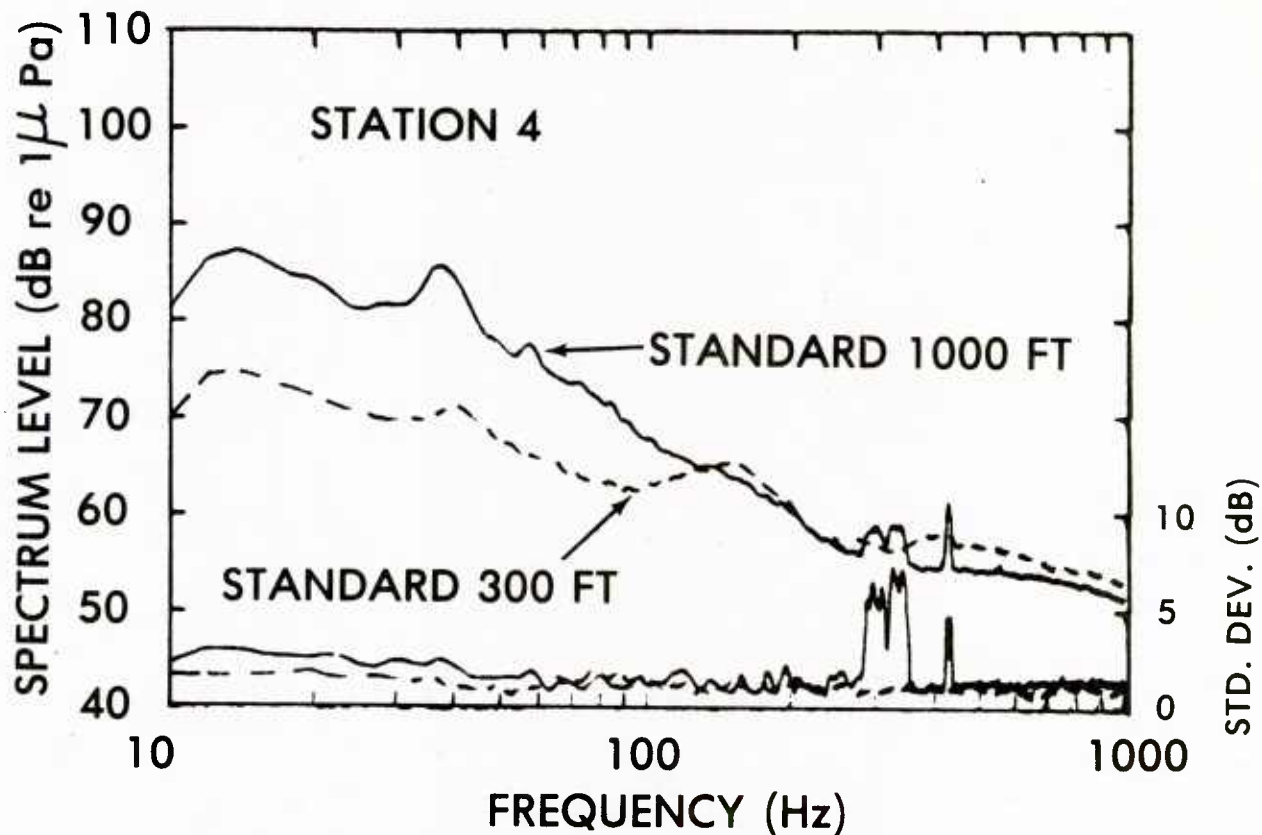

Figure 4D. Ambient noise spectral values from standard sonobuoys at Station 4. Upper curves for each acoustic station represent the 2-Hz ambient noise levels from standard SSQ-57A (300 ft) and standard SSQ-57A (XN-5) (1000 ft) sonobuoys. The lower curves represent the respective standard deviations (scale shown at right). Solid line, 1000 ft; dashed line, 300 ft. The increased values of noise of the 1000 ft buoys below 100 Hz are due to increased self-noise of the measuring system.

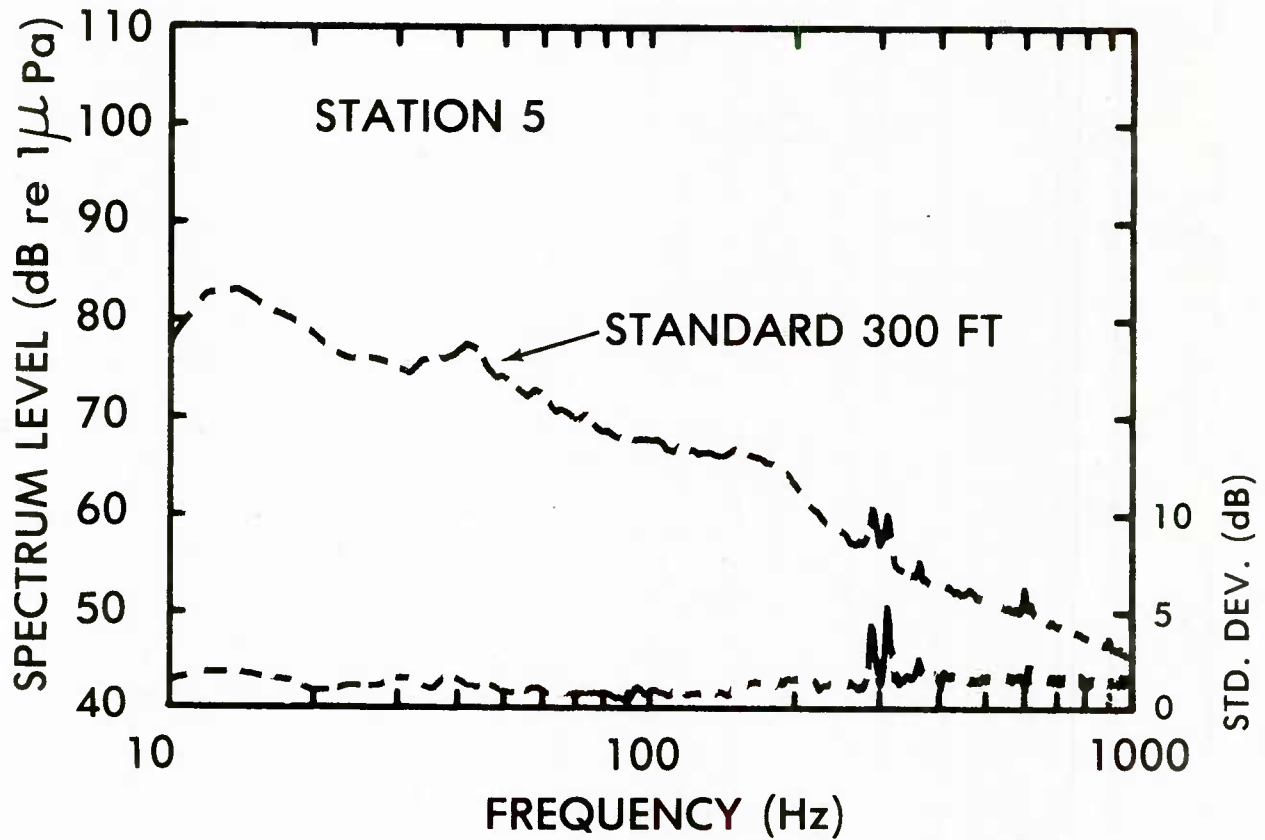

Figure 4E. Ambient noise spectral values from standard sonobuoys at Station 5. Upper curves for each acoustic station represent the 2-Hz ambient noise levels from standard SSQ-57A (300 ft) and standard SSQ-57A (XN-5) (1000 ft) sonobuoys. The lower curves represent the respective standard deviations (scale shown at right). Solid line, 1000 ft; dashed line, 300 ft. The 1000 ft buoy did not function during station 5. The increased values of noise of the 1000 ft buoys below 10 Hz are due to increased self-noise of the measuring system.

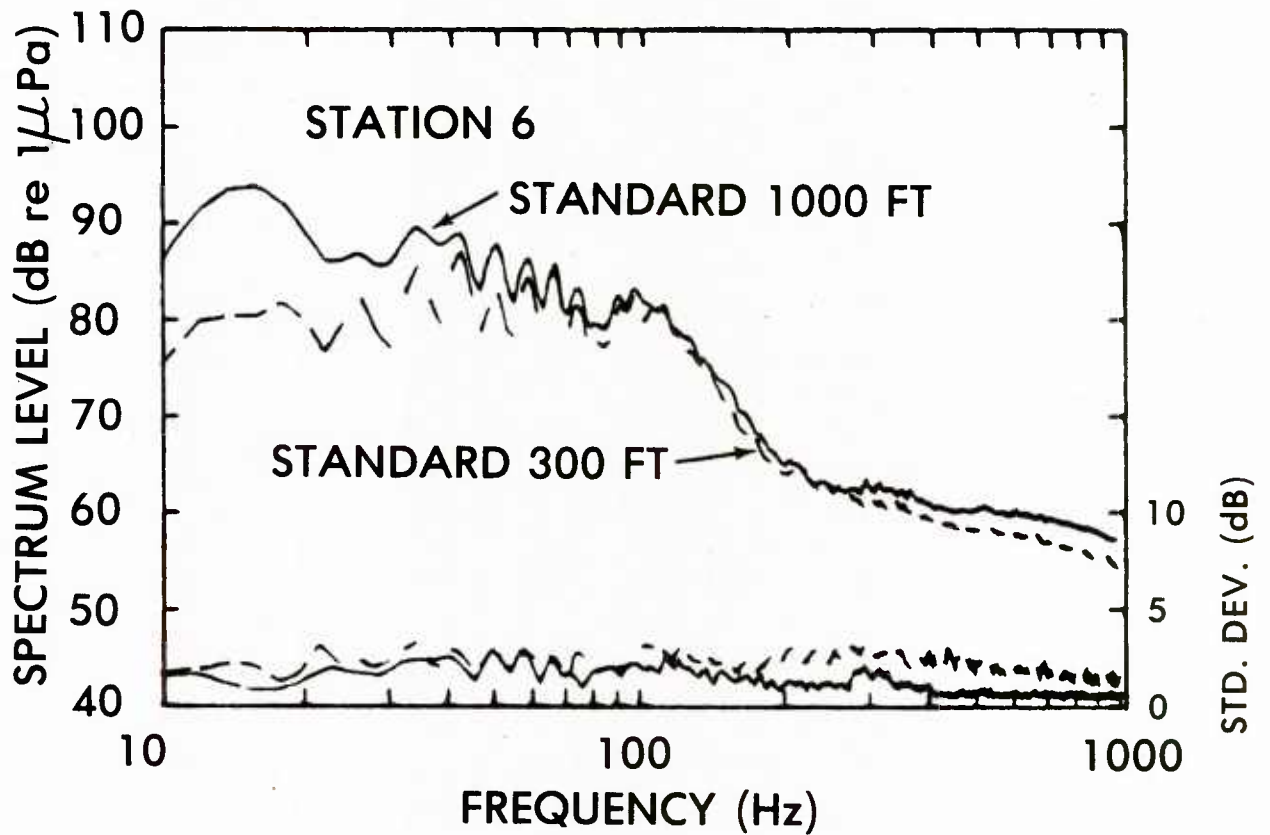

Figure 4F. Ambient noise spectral values from standard sonobuoys at Station 6. Upper curves for each acoustic station represent the 2-Hz ambient noise levels from standard SSQ-57A (300 ft) and standard SSQ-57A (XN-5) (1000 ft) sonobuoys. The lower curves represent the respective standard deviations (scale shown at right). Solid line, 1000 ft; dashed line, 300 ft. The increased values of noise of the 1000 ft buoys below 100 Hz are due to increased self-noise of the measuring system.

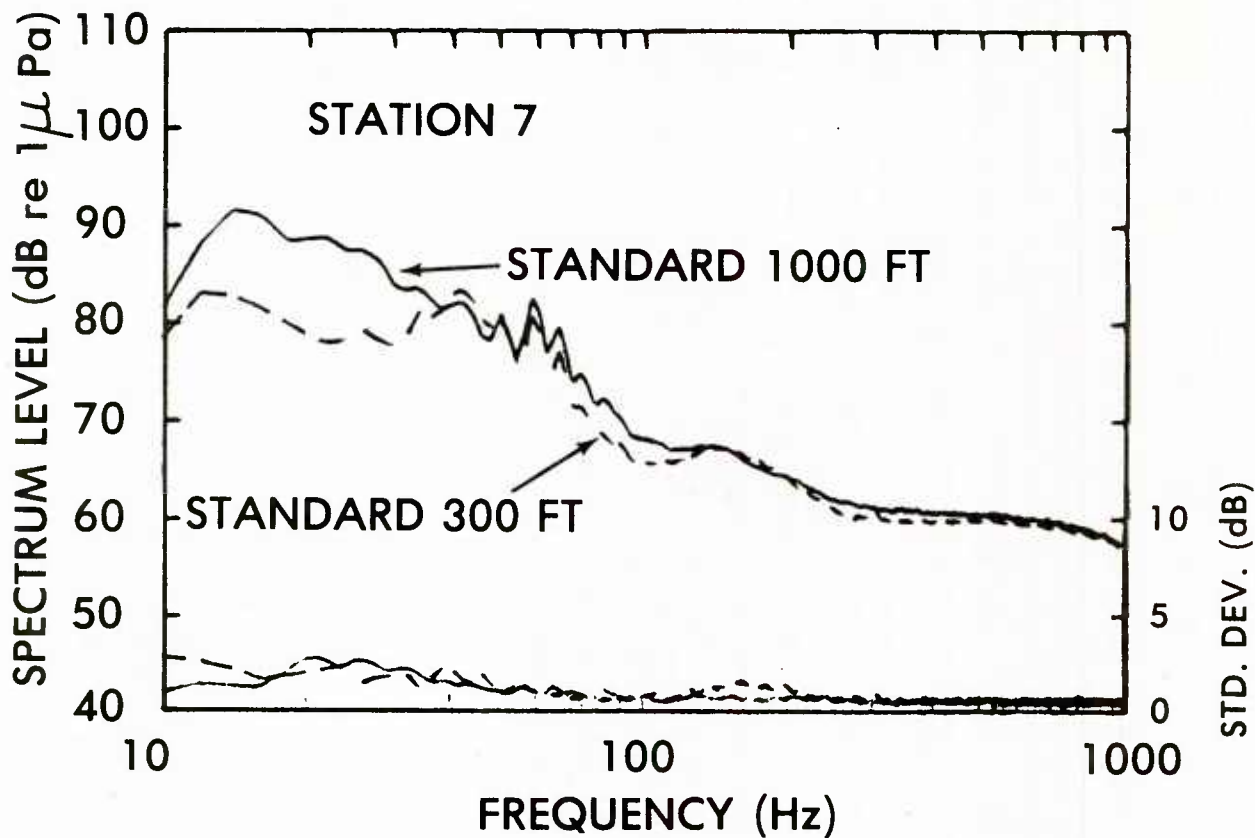

Figure 4G. Ambient noise spectral values from standard sonobuoys at Station 7. Upper curves for each acoustic station represent the 2-Hz ambient noise levels from standard SSQ-57A (300 ft) and standard SSQ-57A (XN-5) (1000 ft) sonobuoys. The lower curves represent the respective standard deviations (scale shown at right). Solid line, 1000 ft; dashed line, 300 ft. The increased values of noise of the 1000 ft buoys below 100 Hz are due to increased self-noise of the measuring system.

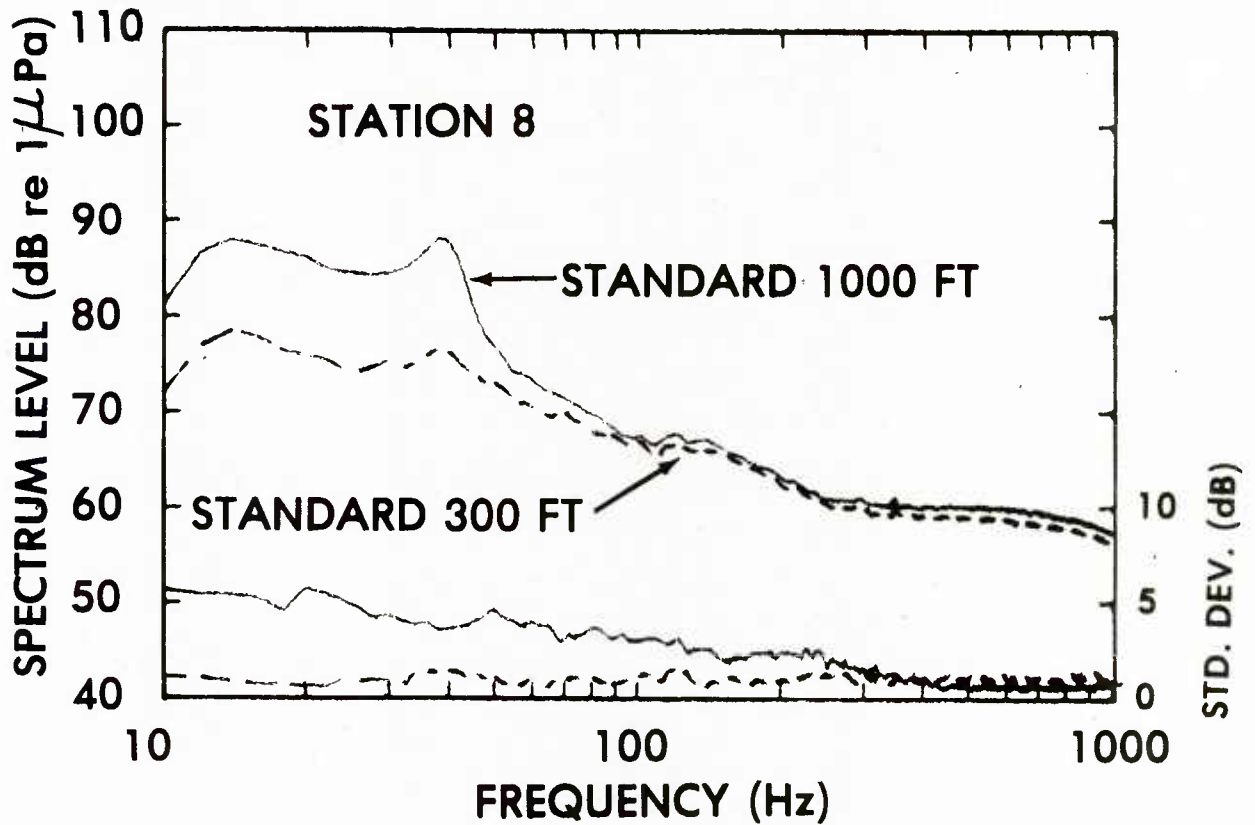

Figure 4H. Ambient noise spectral values from standard sonobuoys at Station 8. Upper curves for each acoustic station represent the 2-Hz ambient noise levels from standard SSQ-57A (300 ft) and standard SSQ-57A (XN-5) (1000 ft) sonobuoys. The lower curves represent the respective standard deviations (scale shown at right). Solid line, 1000 ft; dashed line, 300 ft. The increased values of noise of the 1000 ft buoys below 100 Hz are due to increased self-noise of the measuring system.

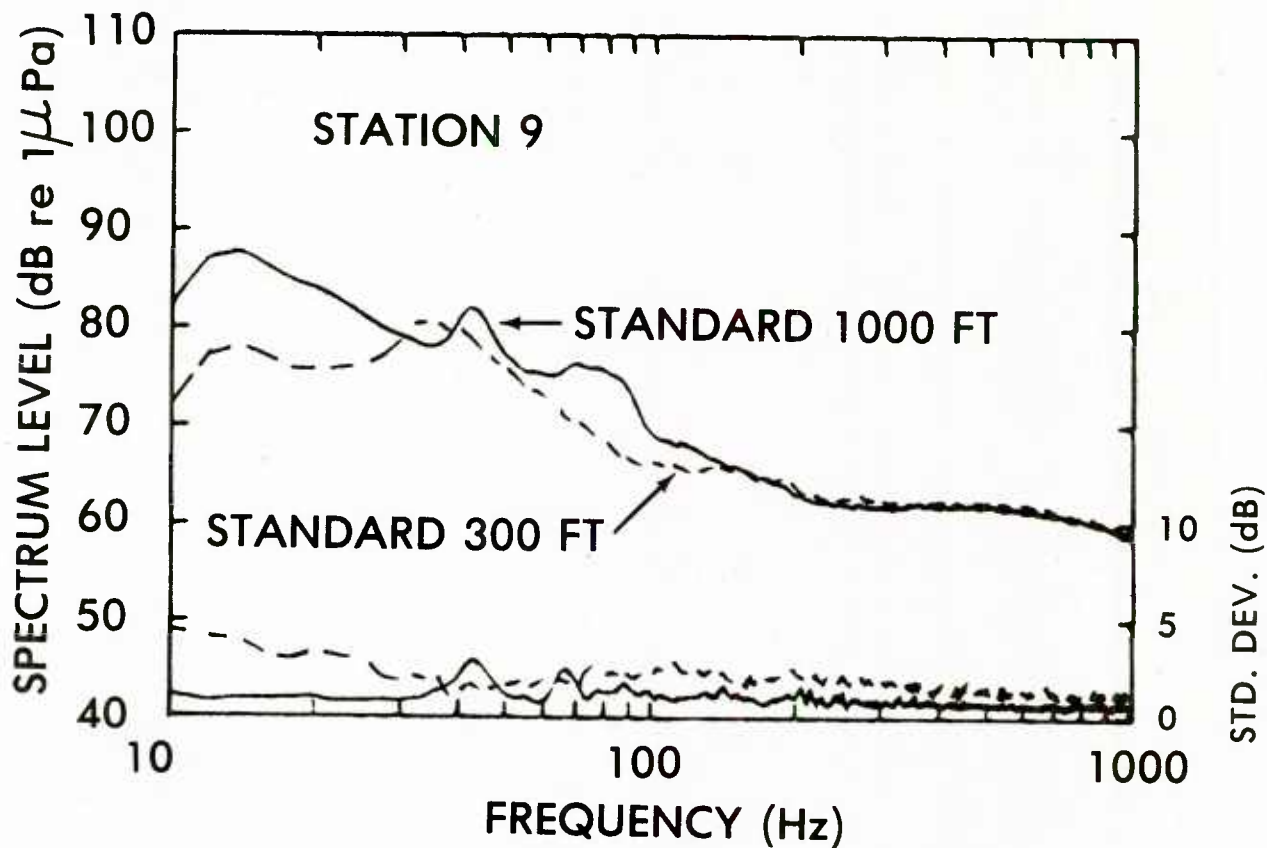

Figure 4I. Ambient noise spectral values from standard sonobuoys at Station 9. Upper curves for each acoustic station represent the 2-Hz ambient noise levels from standard SSQ-57A (300 ft) and standard SSQ-57A (XN-5) (1000 ft) sonobuoys. The lower curves represent the respective standard deviations (scale shown at right). Solid line, 1000 ft; dashed line, 300 ft. The increased values of noise of the 1000 ft buoys below 100 Hz are due to increased self-noise of the measuring system.

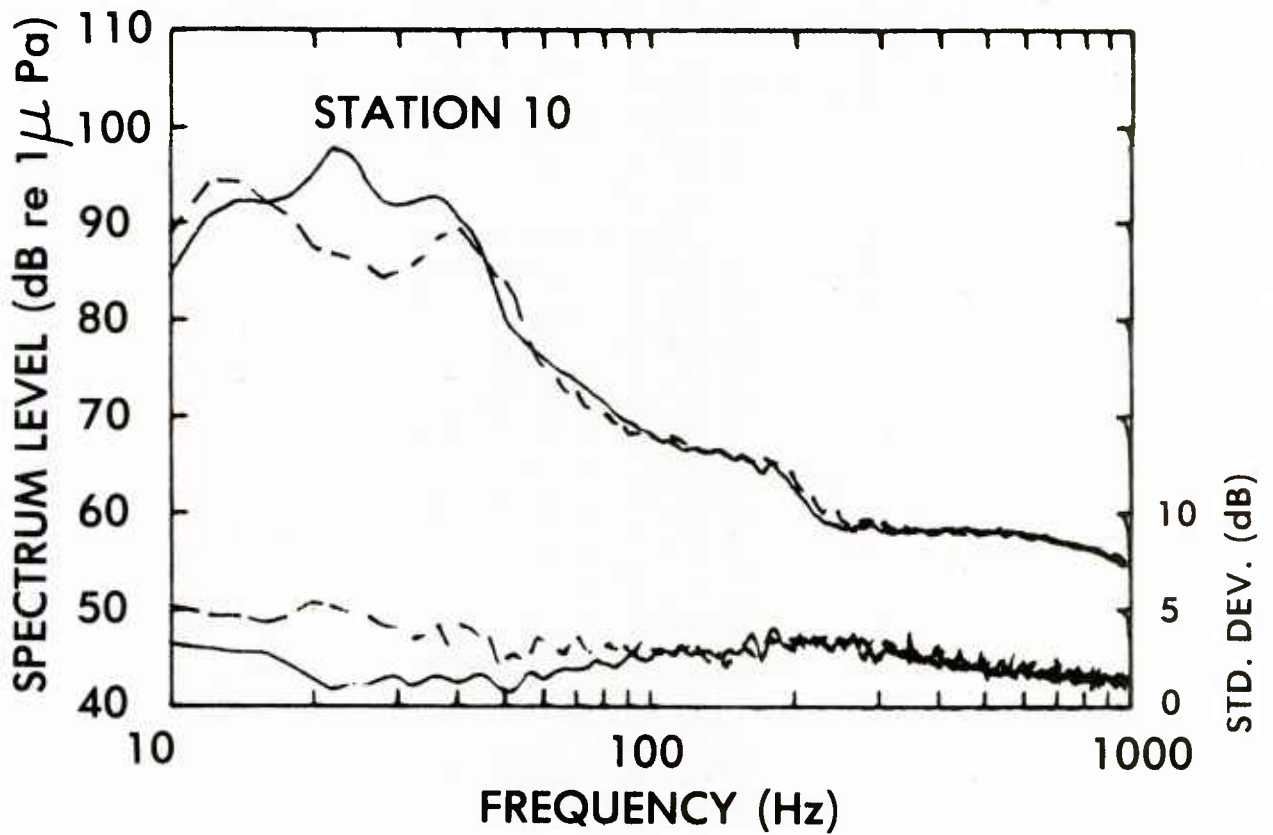

Figure 4J. Ambient noise spectral values from standard sonobuoys at Station 10. Upper curves for each acoustic station represent the 2-Hz ambient noise levels from standard SSQ-57A (300 ft) and standard SSQ-57A (XN-5) (1000 ft) sonobuoys. The lower curves represent the respective standard deviations (scale shown at right). Solid line, 1000 ft; dashed line, 300 ft. The increased values of noise of the 1000 ft buoys below at 100 Hz are due to increased self-noise of the measuring system.

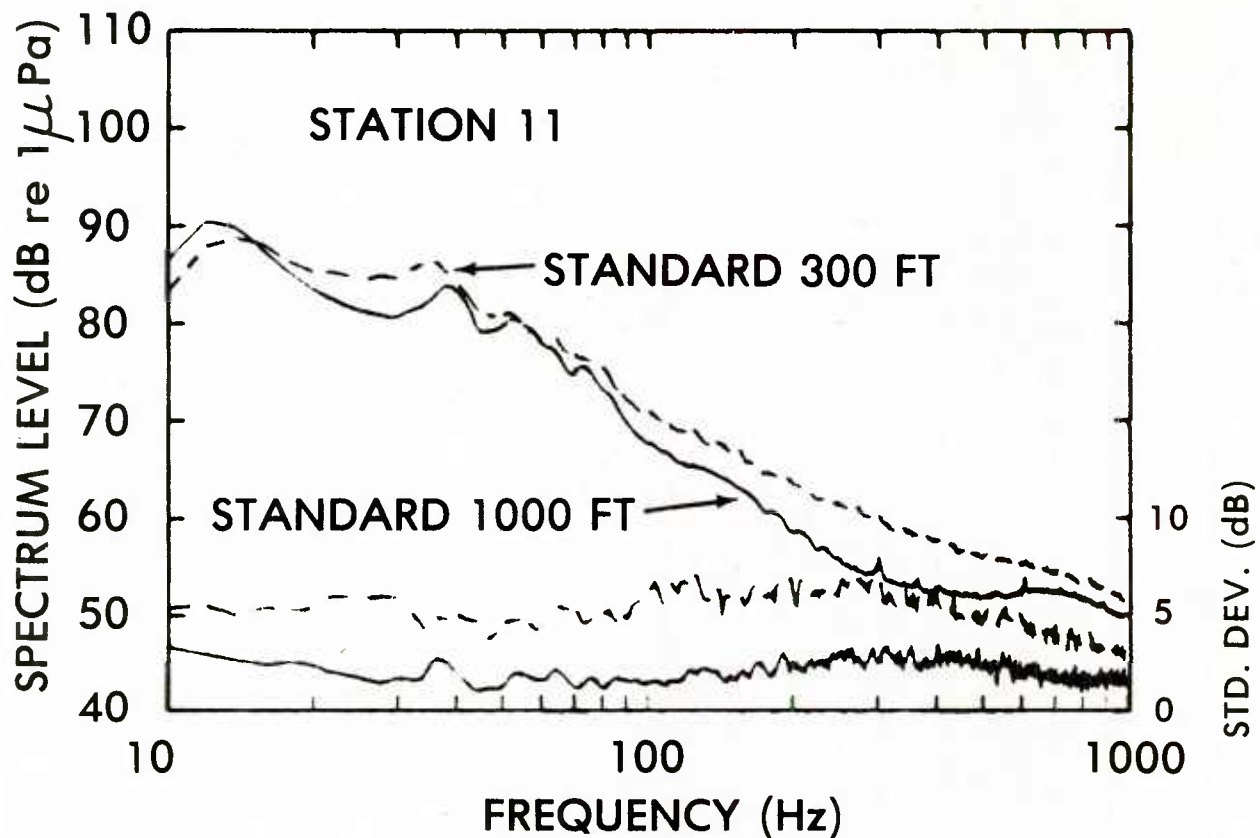

Figure 4K. Ambient noise spectral values from standard sonobuoys at Station 11. Upper curves for each acoustic station represent the 2-Hz ambient noise levels from standard SSQ-57A (300 ft) and standard SSQ-57A (XN-5) (1000 ft) sonobuoys. The lower curves represent the respective standard deviations (scale shown at right). Solid line, 1000 ft; dashed line, 300 ft. The increased values of noise of the 1000 ft buoys below at 100 Hz are due to increased self-noise of the measuring system.

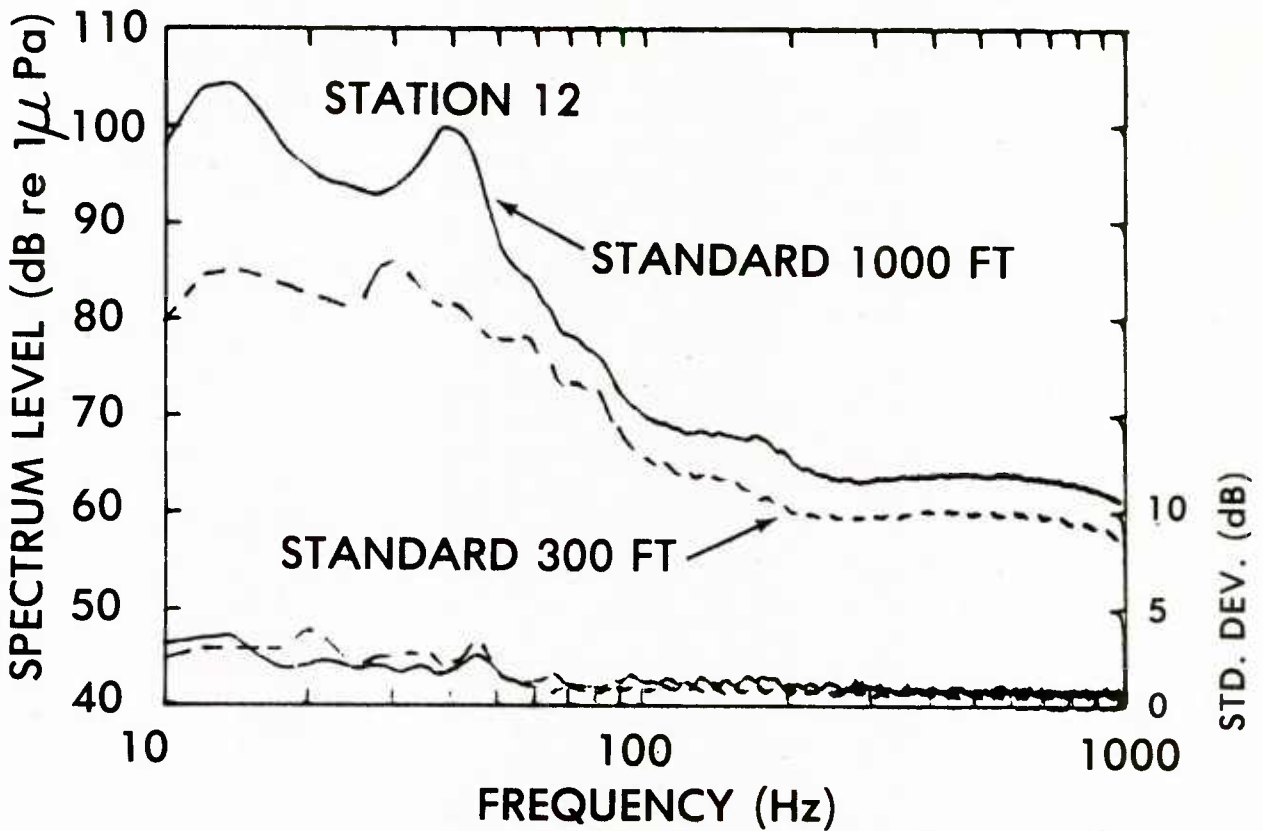

Figure 4L. Ambient noise spectral values from standard sonobuoys at Station 12. Upper curves for each acoustic station represent the 2-Hz ambient noise levels from standard SSQ-57A (300 ft) and standard SSQ-57A (XN-5) (1000 ft) sonobuoys. The lower curves represent the respective standard deviations (scale shown at right). Solid line, 1000 ft; dashed line, 300 ft. The increased values of noise of the 1000 ft buoys below at 100 Hz are due to increased self-noise of the measuring system.

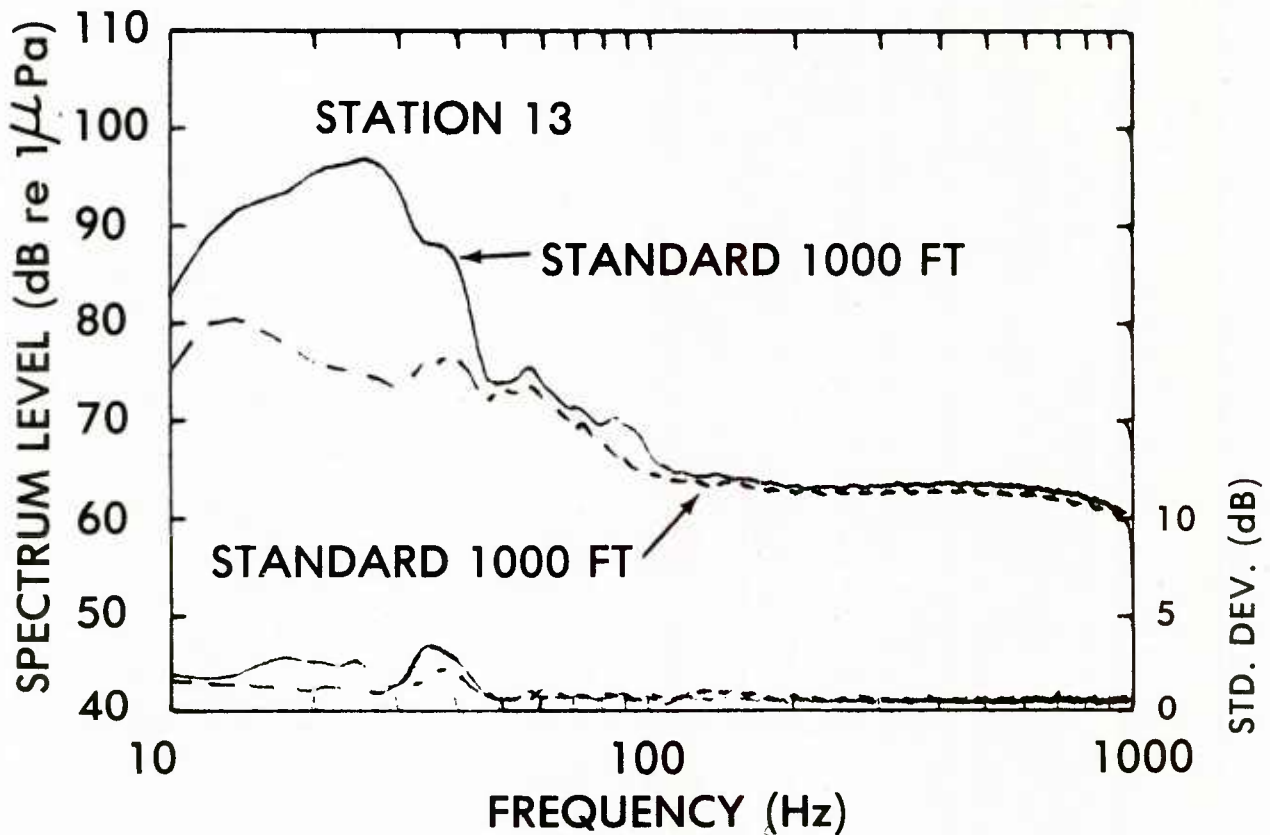

Figure 4M. Ambient noise spectral values from standard sonobuoys at Station 13. Upper curves for each acoustic station represent the 2-Hz ambient noise levels from standard SSQ-57A (300 ft) and standard SSQ-57A (XN-5) (1000 ft) sonobuoys. The lower curves represent the respective standard deviations (scale shown at right). Solid line, 1000 ft; dashed line, 300 ft. The increased values of noise of the 1000 ft buoys below at 100 Hz are due to increased self-noise of the measuring system.

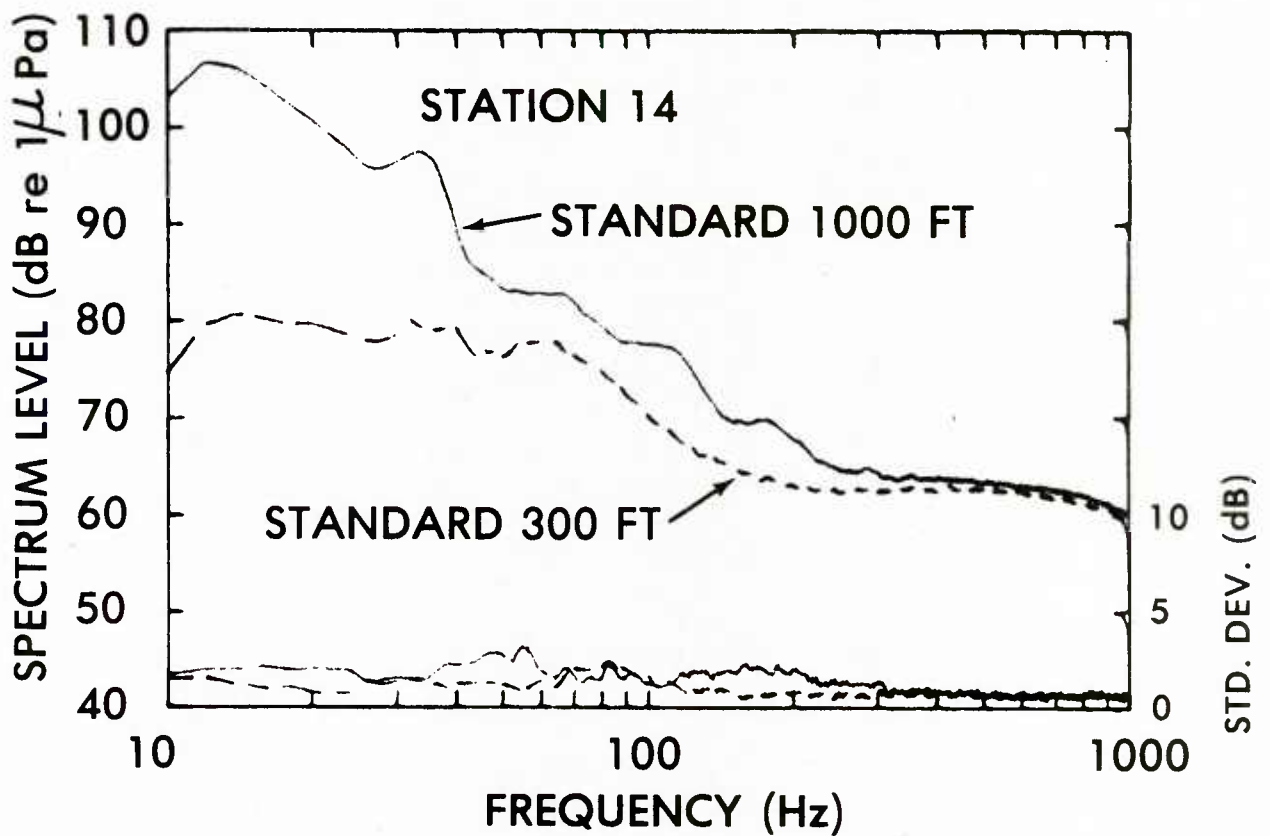

Figure 4N. Ambient noise spectral values from standard sonobuoys at Station 14. Upper curves for each acoustic station represent the 2-Hz ambient noise levels from standard SSQ-57A (300 ft) and standard SSQ-57A (XN-5) (1000 ft) sonobuoys. The lower curves represent the respective standard deviations (scale shown at right). Solid line, 1000 ft; dashed line, 300 ft. The increased values of noise of the 1000 ft buoys below at 100 Hz are due to increased self-noise of the measuring system.

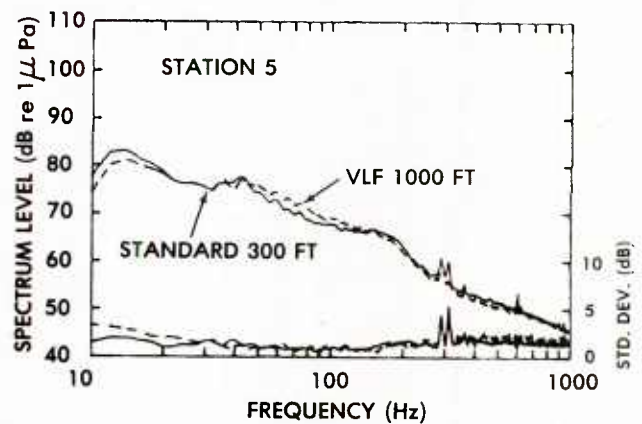
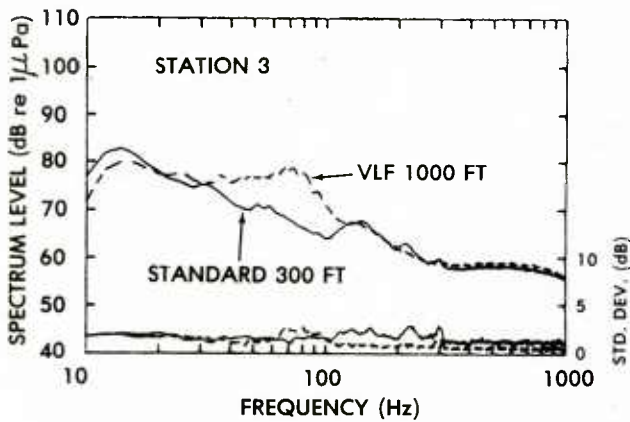
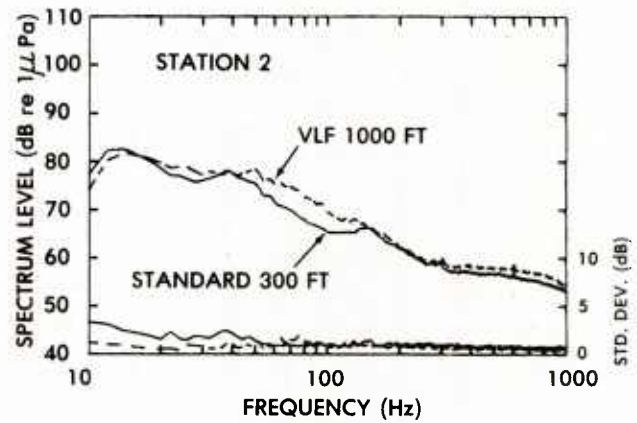
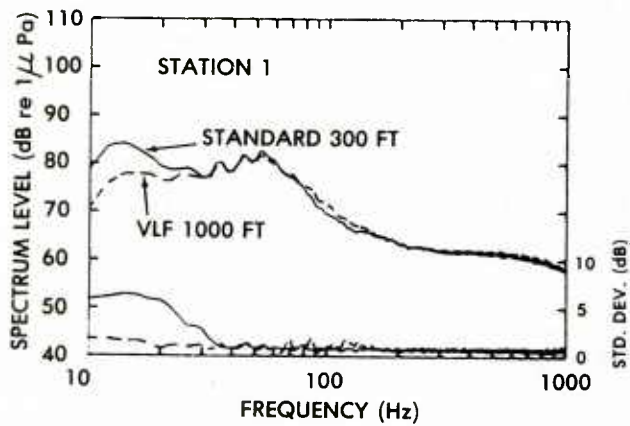

Figure 5. Comparison of ambient noise levels from standard SSQ-57A (300 ft) and VLF-modified SSQ-57A (XN-5) (1000 ft). The lower curves represent the respective standard deviations (scale shown at right). Modifications were versions of the VLF sonobuoy (Ref. 5). The lower self-noise from the VLF sonobuoys results in measured levels similar to the standard SSQ-57A values.

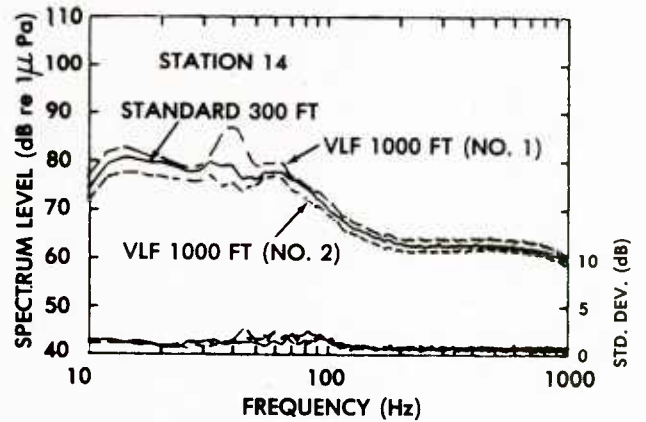
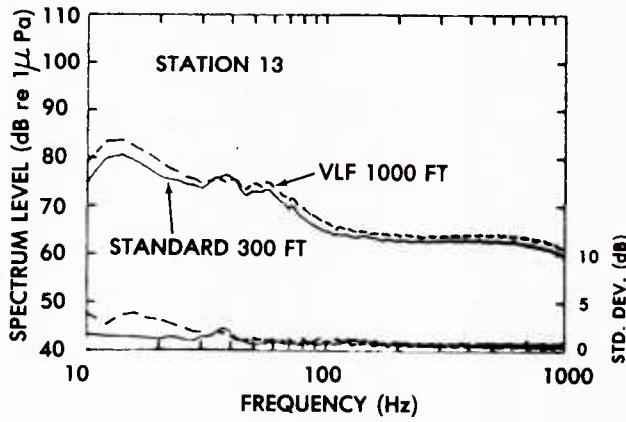
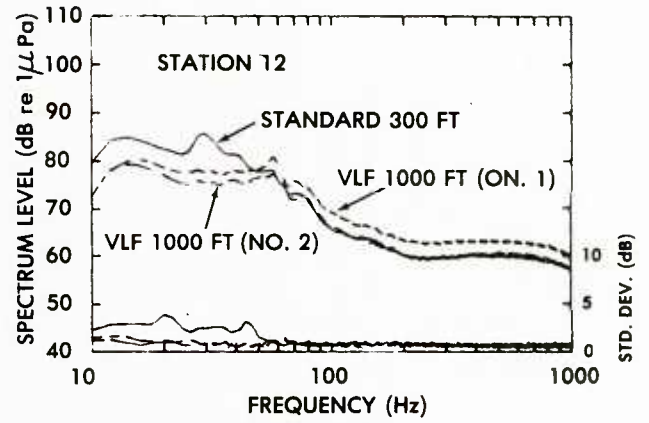
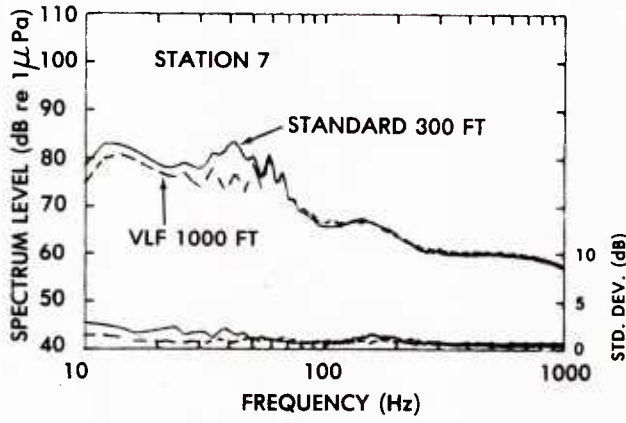

Figure 5. (continued)

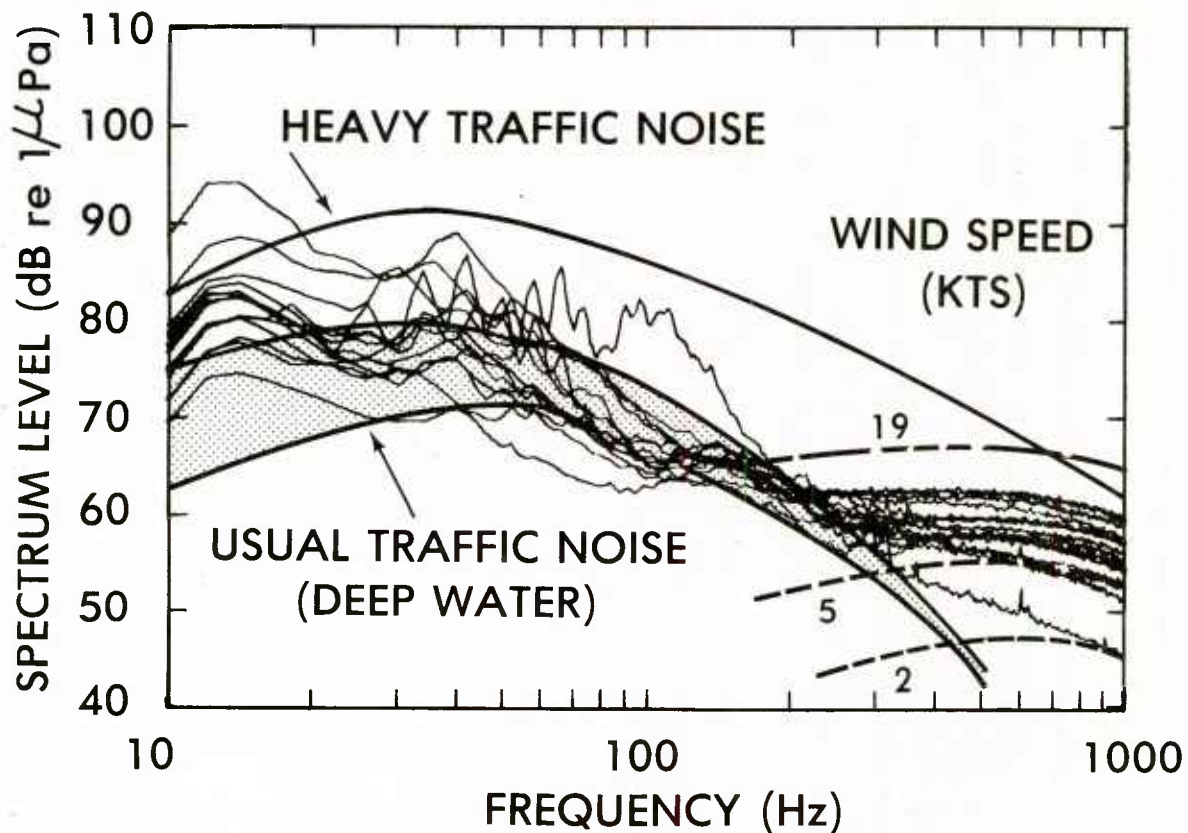

Figure 6. Ambient noise spectra for standard SSQ-57A (300 ft) system. The thick lines indicate average ambient noise levels from Wenz, Ref. 6.

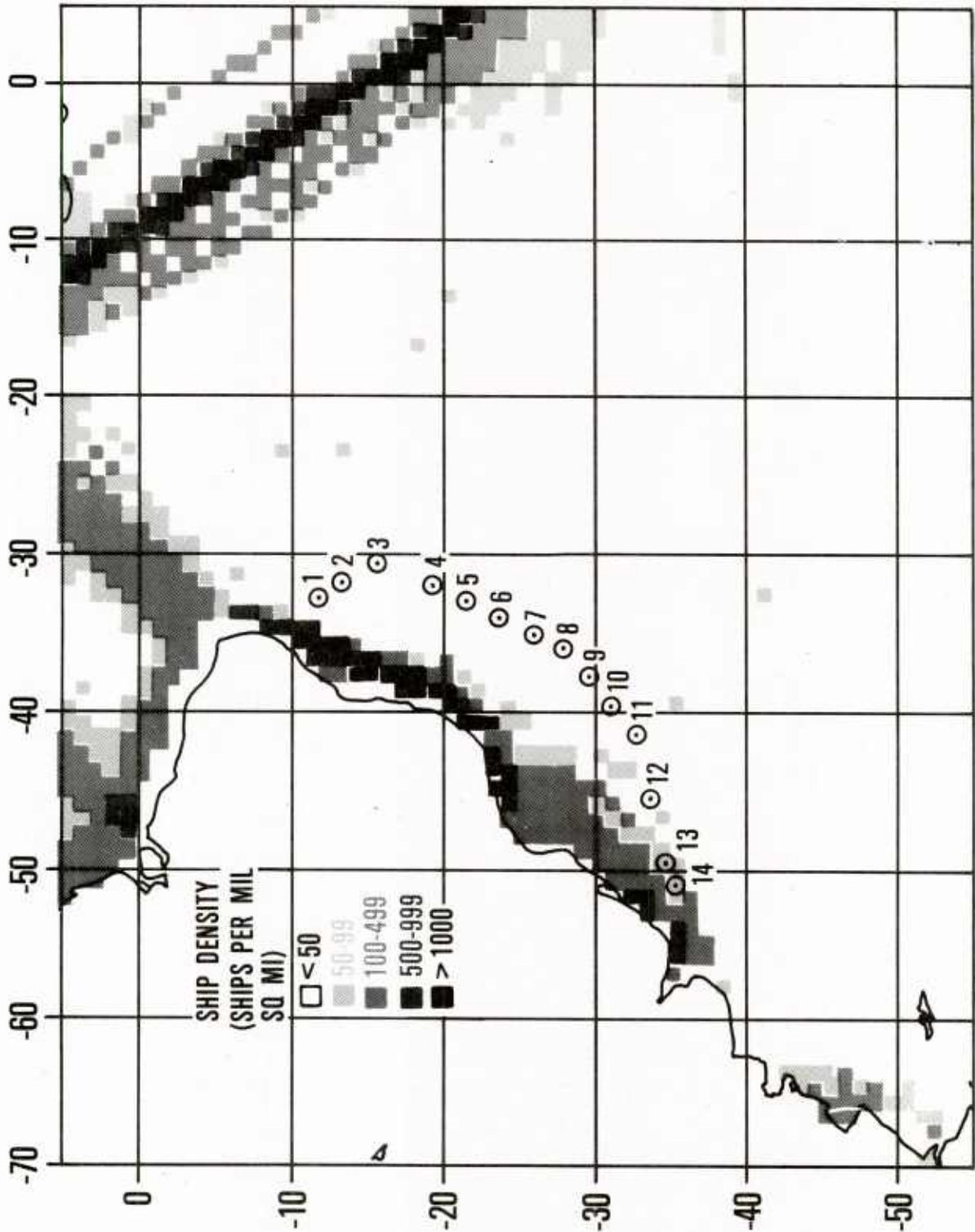

Figure 7. South Atlantic shipping density, summer (Jan, Feb, Mar). Data obtained from Historical Temporal Shipping (Autoship Data Base). Acoustic station locations are indicated.

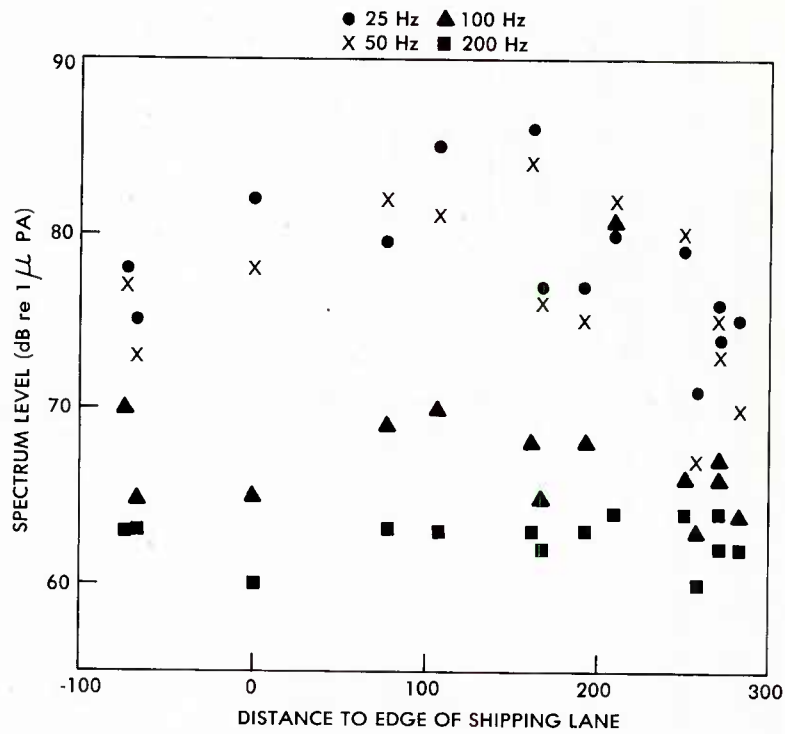

Figure 8. Ambient noise level at selected frequencies vs. distance (nautical miles) to the edge of the Southwest Atlantic coastal shipping lane.

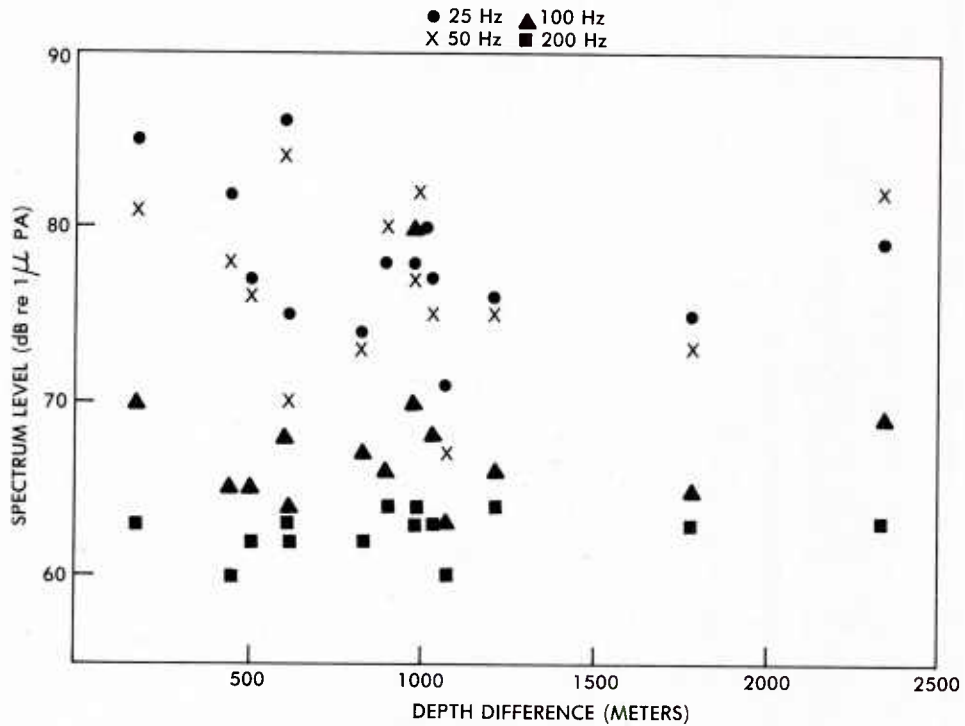

Figure 9. Ambient noise level vs. depth difference. Depth difference is defined as the critical depth minus water depth.

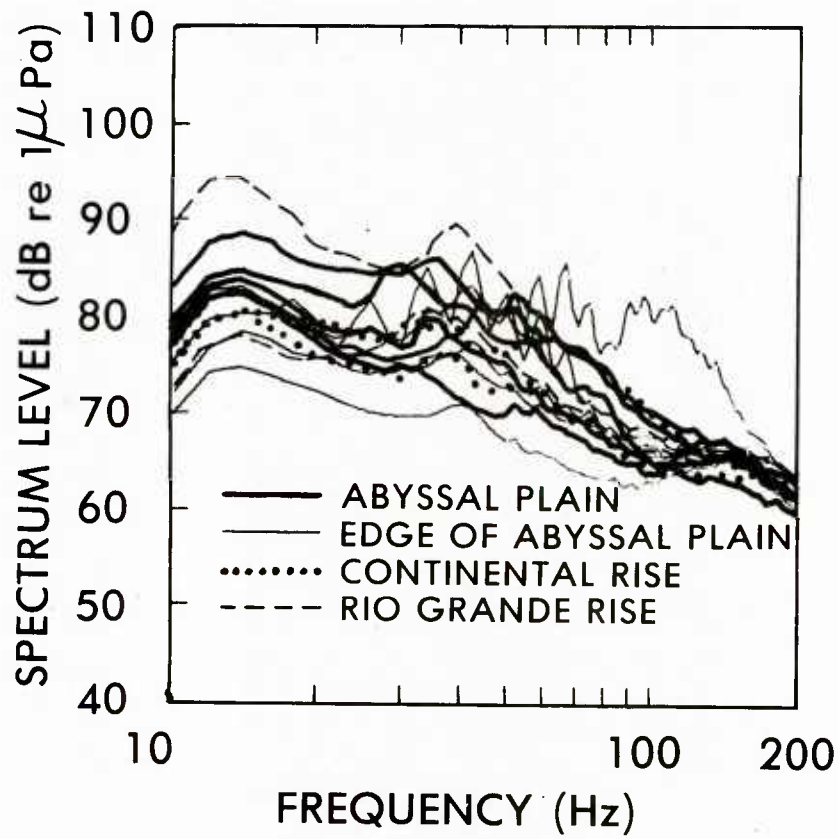

Figure 10. Ambient noise levels for physiographic provinces.

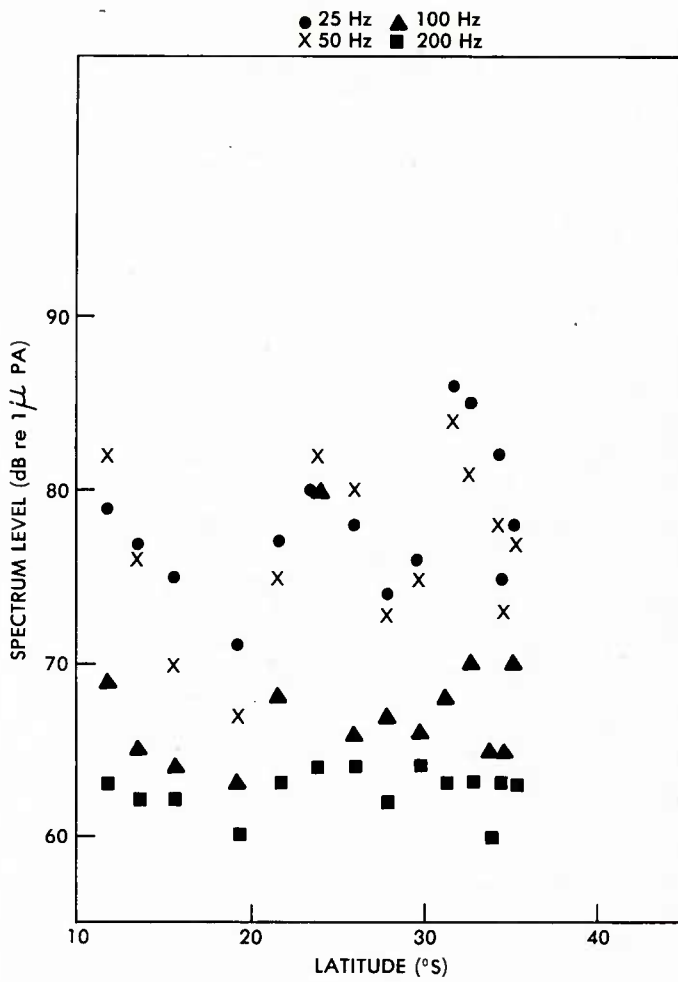

Figure 11. Ambient noise levels for selected frequencies vs. latitude.

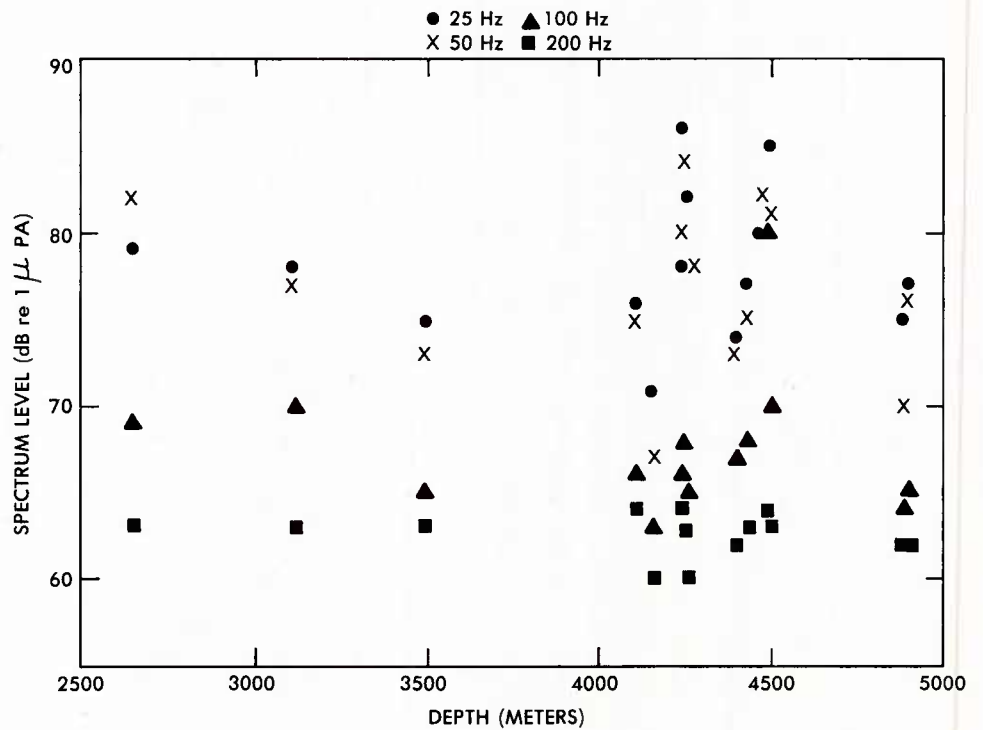

Figure 12. Ambient noise levels at selected frequencies vs. water depth.

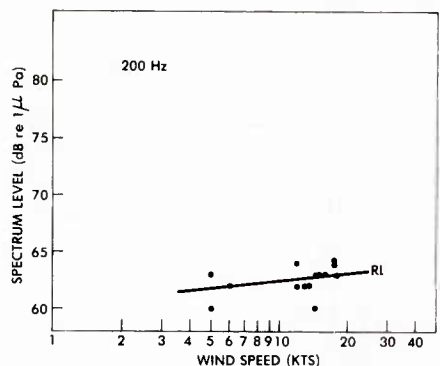
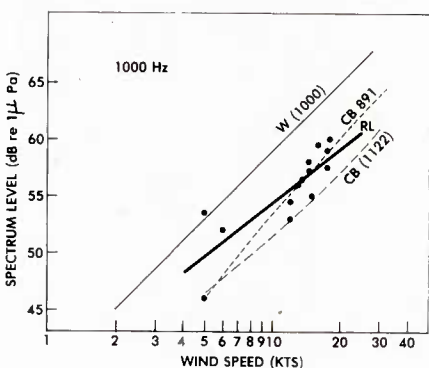
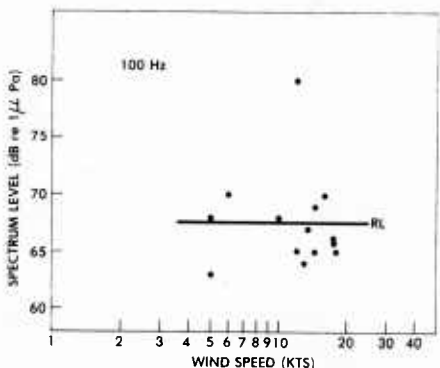
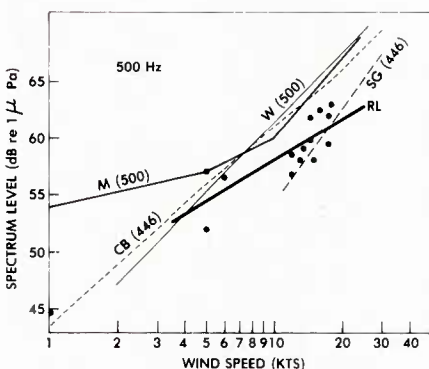
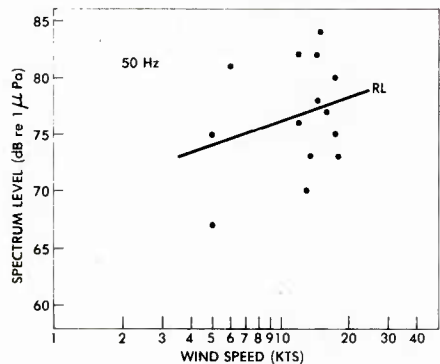
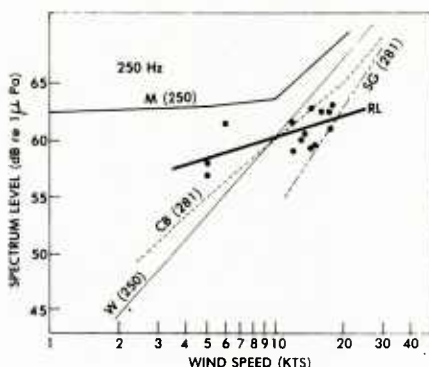
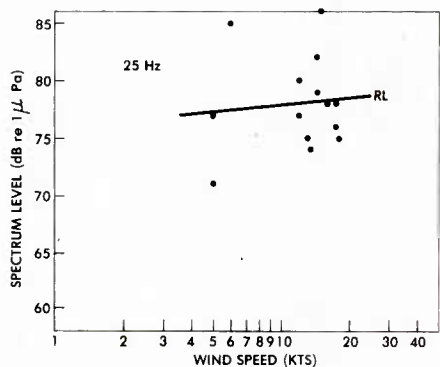

Figure 13. Ambient noise levels vs. log wind speed. The line, RL, is the regression line to the data. Correlation coefficients of these regression lines are given in Table III. The high frequency data are also compared to data from Wenz, Ref. 6; Crouch and Burt, Ref. 9; Morris, Ref. 10; and Shooter and Gentry, Ref. 11, denoted by W, CB, M, and SG, respectively. The frequency of these data is given in parentheses following the identifying letter(s).

APPENDIX

The sonobuoy signals were received on an ARR-75 sonobuoy receiver and recorded with a seven-channel Racal analog tape recorder (Fig. 14A) at 3 3/4 IPS for about one hour. The FM recording mode provides a usable bandwidth from DC to about 1250 Hz per channel. At each site, signals from at least two sonobuoys were recorded at two different gains. During the experiment, ambient noise levels were estimated with a single-channel spectrum analyzer (Fig. 14A). To guard against overloading due to excessive gain in the recording system, we checked its fidelity by comparing spectra before and after recording. After finishing the ambient noise recording at each acoustic station, CW tones from 20 Hz-1500 Hz were injected and recorded on each tape track for calibration (Fig. 14A).

The first step in processing these data in the laboratory was to display the broad-band ambient noise data as a time series on a Sanborn recording to identify any channels or time periods having problems such as RF fadeouts or unusual transients. Then the tape data were processed by the system of Figure 14B to obtain ambient noise spectral levels.

The signals were first passed through a band-pass filter, 10-1000 Hz, and then digitized in 0.5 sec sections at a sampling rate of 2048 Hz. A 1024-point discrete Fourier transform using a Hann window was taken to obtain 3-Hz resolution spectra over the band of 10-1000 Hz. Fifty 0.5 sec sections separated by 1.1 sec processing times were averaged over an 80 sec period by equation (1) to obtain a decibel smoothed spectral estimate, B_f . Sixteen such spectra were averaged over a 25-minute interval by equations (2) and (3)

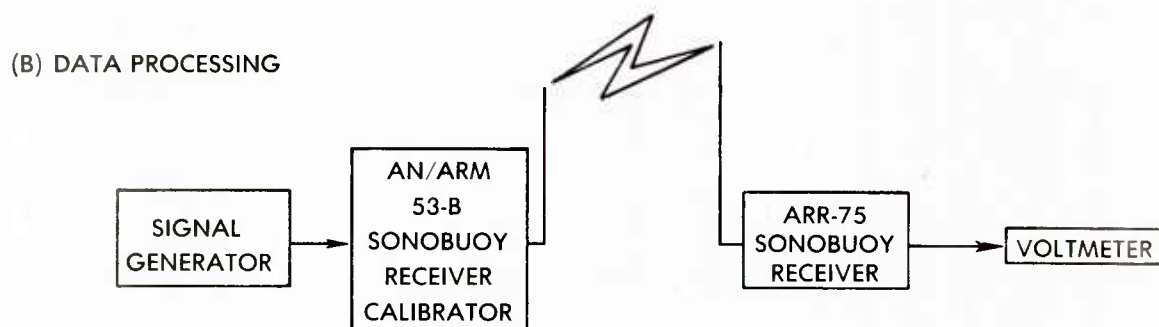
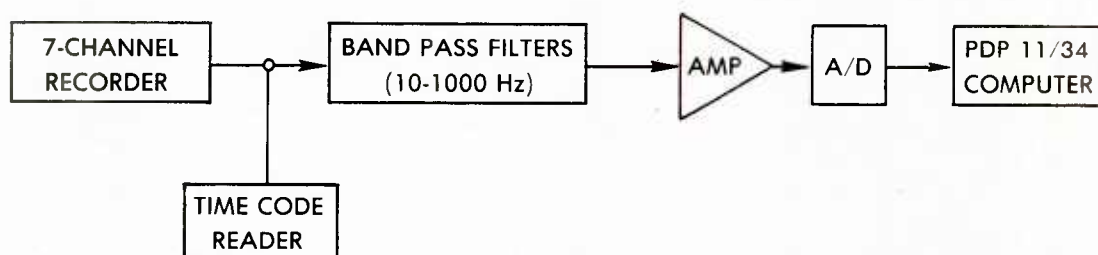
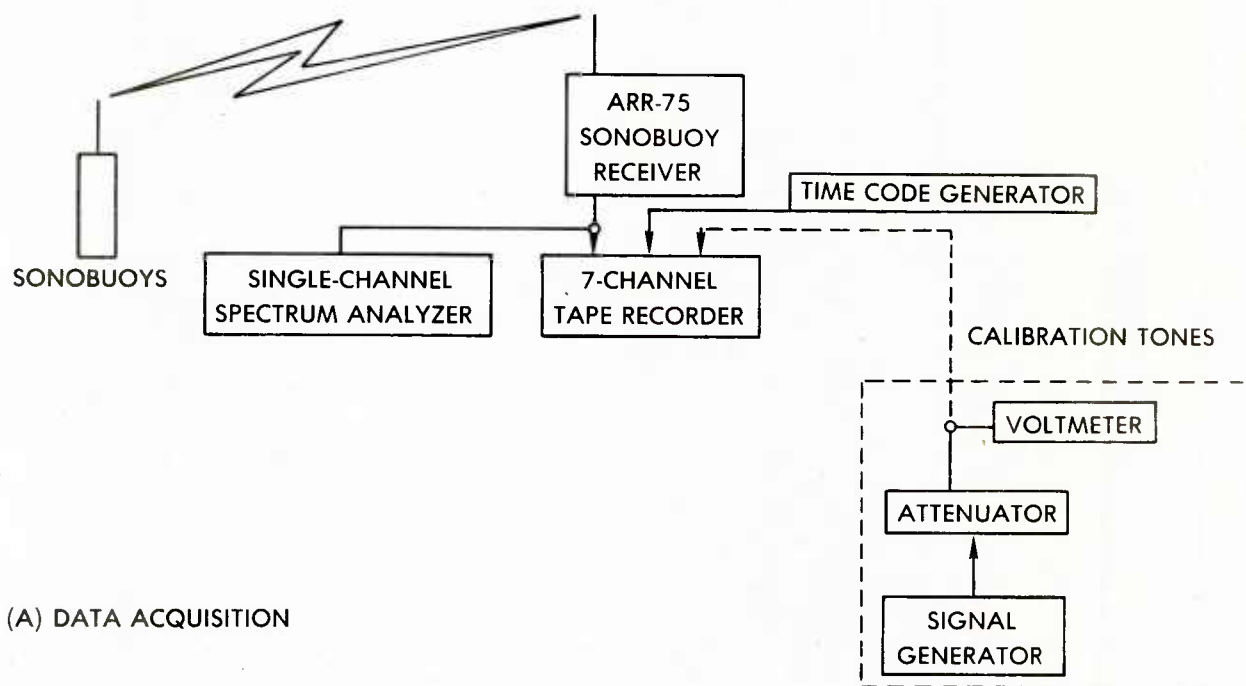

Figure 14. Block diagram of acoustic data acquisition and processing system.

$$B_f(I) = 10 \text{ Log} \frac{1}{50} \sum_{J=1}^{50} A_f(I,J) \quad (1)$$

$$RL_f = \frac{1}{16} \sum_{I=1}^{16} B_f(I) \quad (2)$$

$$SD = \left\{ \frac{1}{15} \left[\sum_{I=1}^6 B_f^2(I) - 16 (RL_f)^2 \right] \right\}^{\frac{1}{2}} \quad (3)$$

where A_f = Raw spectral estimate

B_f = Decibel smoothed spectral estimate

RL_f = Decibel mean spectral estimate

A_f = Decibel standard deviation of
the spectral estimate

to obtain mean and standard deviation of the ambient noise. The interval of uncertainty of these estimates is less than 1 dB at the 95% confidence level (Ref. 14).

Corrected mean spectral levels of ambient noise, $CSL(f)$, were obtained using equation (4).

$$CSL(f) = RL_f + SFG_{440} - SFG(f) - RCAL(f) - TPG(f) - 10 \text{ Log BW} \quad (4)$$

where

SFG_{440} = Sonobuoy frequency gain at 440 Hz = 112

$SFG(f)$ = Sonobuoy frequency gain relative to 440 Hz =
standard values

$RCAL(f)$ = Receiver calibration factor = 0

$TPG(f)$ = Gains from tape recording + tape reproduce +
processing system

BW = Bandwidth = 3 Hz

TPG(f) was determined for each channel for each station by playing back the calibration tones through the processing system (Fig. 14C). The receiver calibration factor, RCAL(f), was determined to be 0 by a post-experiment receiver calibration using the AN/ARM-53B sonobuoy calibration system (Fig. 14C). While the individual sonobuoys were uncalibrated, values for the sonobuoy gain, SFG_{440} and SFG(f), were obtained from the manufacturer's sonobuoy calibration specification table. The use of these nominal values results in an estimated uncertainty of 2 dB in the CSL(f).

U210907

h