

12

AD A 137333

IDA RECORD DOCUMENT D-33

FIBER OPTICS TECHNOLOGY  
WORKING GROUP REPORT  
(IDA/OSD R&M STUDY)  
PART I--EXECUTIVE SUMMARY

Andrew S. Glista, Jr.  
*Naval Air Systems Command*  
Rodney S. Katz  
*Naval Avionics Center*  
Working Group Co-Chairmen

SELECTED  
JAN 19 1984  
A

August 1983

The views expressed within this document are those of the working group only. Publication of this document does not indicate endorsement by IDA, its staff, or its sponsoring agencies.

*Prepared for*  
Office of the Under Secretary of Defense for Research and Engineering  
*and*  
Office of the Assistant Secretary of Defense  
(Manpower, Reserve Affairs and Logistics)

This document has been approved for public release and sale; its distribution is unlimited.

DTIC FILE COPY



INSTITUTE FOR DEFENSE ANALYSES  
SCIENCE AND TECHNOLOGY DIVISION

84 01 19 003

The work reported in this document was conducted under contract MDA 903 79 C 0016 for the Department of Defense. The publication of this ICA Record Document does not indicate endorsement by the Department of Defense, nor should the contents be construed as reflecting the official position of that agency.

Approved for public release; distribution unlimited.

# UNCLASSIFIED

SECURITY CLASSIFICATION OF THIS PAGE (When Data Entered)

REPORT DOCUMENTATION PAGE		READ INSTRUCTIONS BEFORE COMPLETING FORM
1. REPORT NUMBER	2. GOVT ACCESSION NO. <i>AD-4157-333</i>	3. RECIPIENT'S CATALOG NUMBER
4. TITLE (and Subtitle) Fiber Optics Technology Working Group Report (IDA/OSD R&M Study) Part I--Executive Summary		5. TYPE OF REPORT & PERIOD COVERED FINAL July 1982 - August 1983
7. AUTHOR(s) Andrew S. Glista, Jr., Naval Air Systems Command Rodney S. Katz, Naval Avionics Center		6. PERFORMING ORG. REPORT NUMBER IDA Record Document D-33 8. CONTRACT OR GRANT NUMBER(s) MDA 903 79 C 0018
9. PERFORMING ORGANIZATION NAME AND ADDRESS INSTITUTE FOR DEFENSE ANALYSES 1801 N. Beauregard Street Alexandria, Virginia 22311		10. PROGRAM ELEMENT, PROJECT, TASK AREA & WORK UNIT NUMBERS Task T-2-126
11. CONTROLLING OFFICE NAME AND ADDRESS Office of the Assistant Secretary of Defense (MRA&L), The Pentagon Washington, D.C. 20301		12. REPORT DATE August 1983
14. MONITORING AGENCY NAME & ADDRESS (if different from Controlling Office) DoD-IDA Management Office 1801 N. Beauregard Street Alexandria, Virginia 22311		13. NUMBER OF PAGES 39
16. DISTRIBUTION STATEMENT (of this Report)  Approved for public release; distribution unlimited.		15. SECURITY CLASS. (of this report) UNCLASSIFIED
17. DISTRIBUTION STATEMENT (of the abstract entered in Block 20, if different from Report)  None		15a. DECLASSIFICATION/DOWNGRADING SCHEDULE ---
18. SUPPLEMENTARY NOTES  N/A		
19. KEY WORDS (Continue on reverse side if necessary and identify by block number) reliability, maintainability, readiness, fiber optics, material readiness, military systems, operational readiness, data transmission, optical fibers, guided light transmission, cable assembly, optical sensors		
20. ABSTRACT (Continue on reverse side if necessary and identify by block number)  This document records the Executive Summary portion of the Fiber Optics Technology Working Group report, part of the IDA/OSD Reliability and Main- tainability Study conducted during the period from July 1982 through August 1983.		

## UNCLASSIFIED

SECURITY CLASSIFICATION OF THIS PAGE (When Data Entered)



# RELIABILITY AND MAINTAINABILITY STUDY

## — REPORT STRUCTURE —

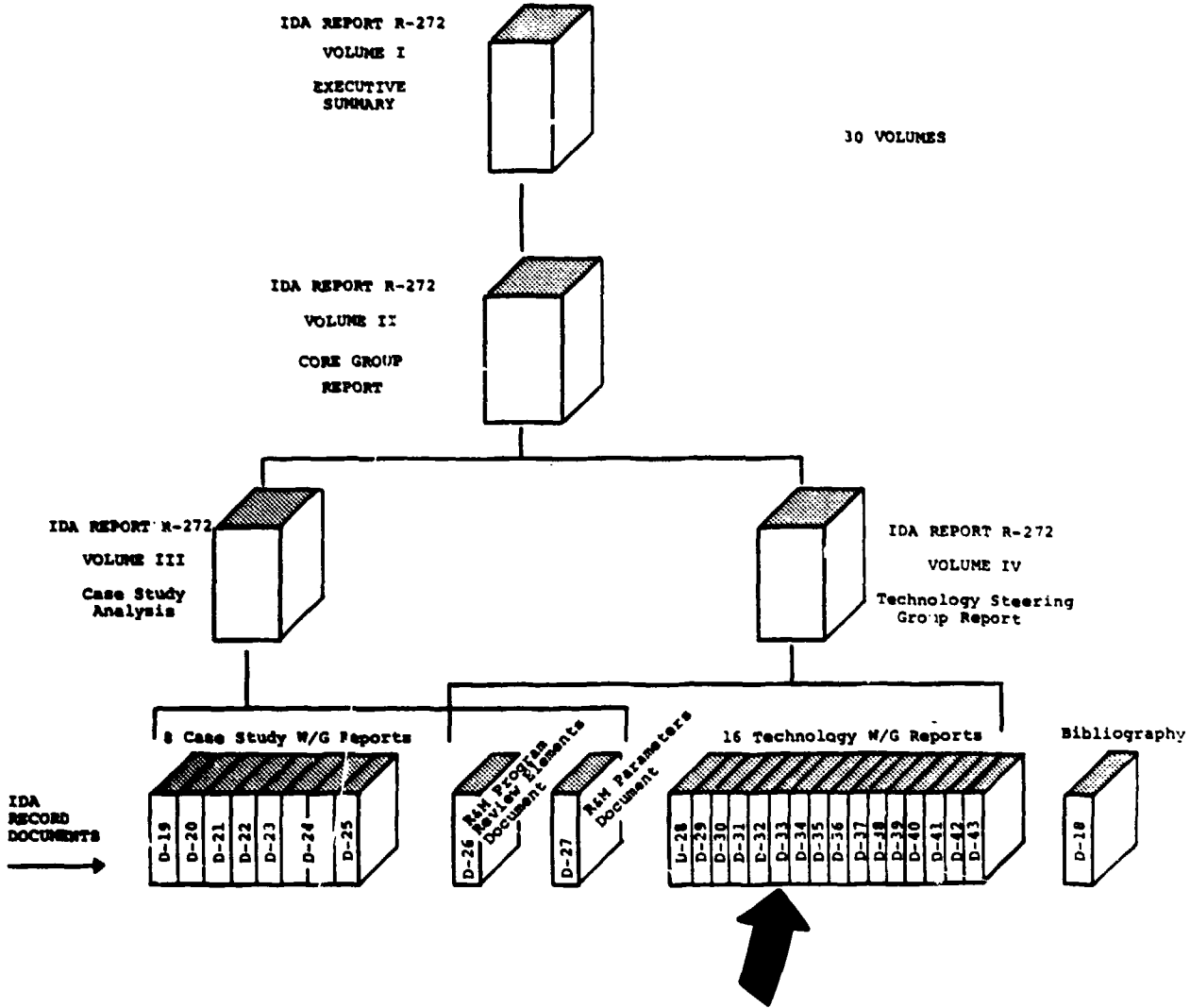

(IDA RECORD DOCUMENT D-33--Part I  
EXECUTIVE SUMMARY)

## PREFACE

As a result of the 1981 Defense Science Board Summer Study on Operational Readiness, Task Order T-2-126 was generated to look at potential steps toward improving the Material Readiness Posture of DoD (Short Title: R&M Study). This task order was structured to address the improvement of R&M and readiness through innovative program structuring and applications of new and advancing technology. Volume I summarizes the total study activity. Volume II integrates analysis relative to Volume III, program structuring aspects, and Volume IV, new and advancing technology aspects.

The objective of this study as defined by the task order is:

"Identify and provide support for high payoff actions which the DoD can take to improve the military system design, development and support process so as to provide quantum improvement in R&M and readiness through innovative uses of advancing technology and program structure."

The scope of this study as defined by the task order is:

To (1) identify high-payoff areas where the DoD could improve current system design, development program structure and system support policies, with the objective of enhancing peacetime availability of major weapons systems and the potential to make a rapid transition to high wartime activity rates, to sustain such rates and to do so with the most economical use of scarce resources possible, (2) assess the impact of advancing technology on the recommended approaches and guidelines, and (3) evaluate the potential and recommend strategies that might result in quantum increases in R&M or readiness through innovative uses of advancing technology.

The approach taken for the study was focused on producing meaningful implementable recommendations substantiated by quantitative data with implementation plans and vehicles to be provided where practical. To accomplish this, emphasis was placed upon the elucidation and integration of the expert knowledge and experience of engineers, developers, managers, testers and users involved with the complete acquisition cycle of weapons systems programs as well as upon supporting analysis. A search was conducted through major industrial companies, a director was selected and the following general plan was adopted.

#### General Study Plan

- Vol. III ● Select, analyze and review existing successful program
- Vol. IV ● Analyze and review related new and advanced technology
- Vol. II (● Analyze and integrate review results  
(● Develop, coordinate and refine new concepts
- Vol. I ● Present new concepts to DoD with implementation plan and recommendations for application.

The approach to implementing the plan was based on an executive council core group for organization, analysis, integration and continuity; making extensive use of working groups, heavy military and industry involvement and participation, and coordination and refinement through joint industry/service analysis and review. Overall study organization is shown in Fig. P-1.

The basic technology study approach was to build a foundation for analysis and to analyze areas of technology to surface: technology available today which might be applied more broadly; technology which requires demonstration to finalize and reduce risk; and technology which requires action today to provide reliable and maintainable systems in the future. Program structuring implications were also considered. Tools used to accomplish

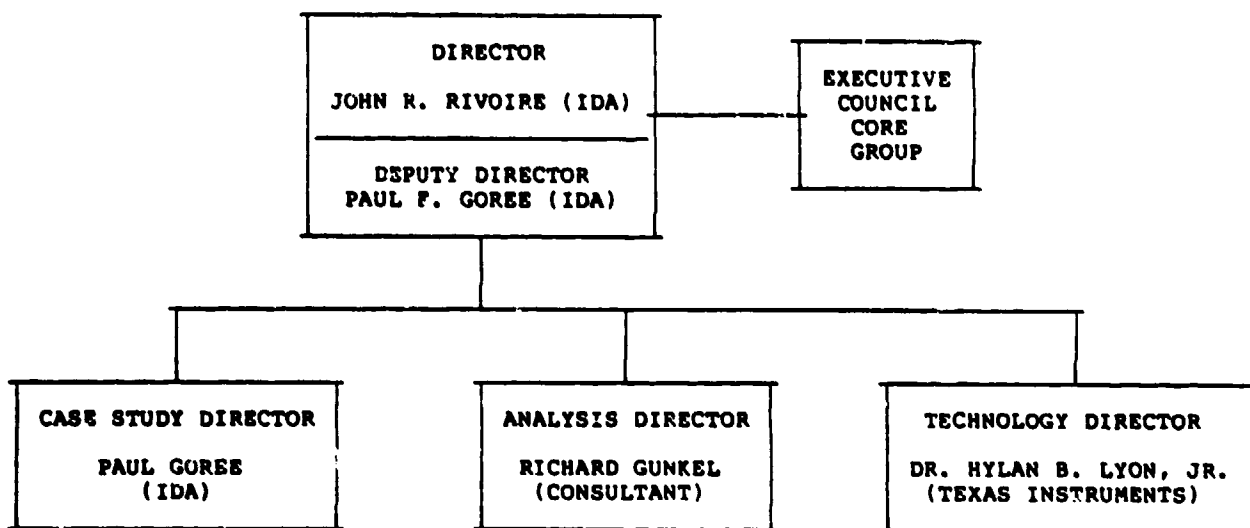

FIGURE P-1. Study Organization

this were existing documents, reports and study efforts such as the Militarily Critical Technologies List. To accomplish the technology studies, sixteen working groups were formed and the organization shown in Fig. P-2 was established.

This document records the activities and findings of the Technology Working Group for the specific technology as indicated in Fig. P-2. The views expressed within this document are those of the working group only. Publication of this document does not indicate endorsement by IDA, its staff, or its sponsoring agencies.

Without the detailed efforts, energies, patience and candidness of those intimately involved in the technologies studied, this technology study effort would not have been possible within the time and resources available.



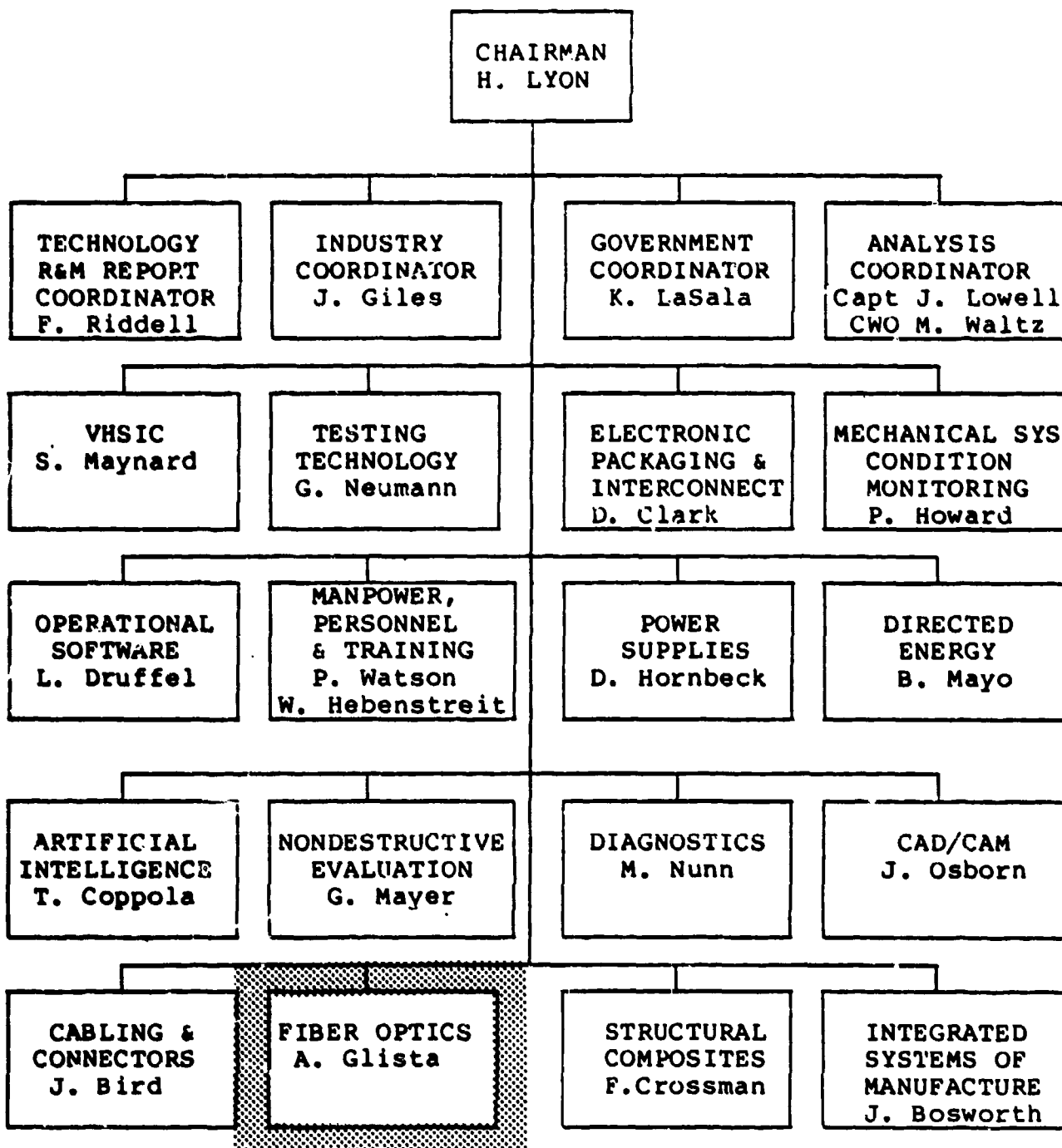

FIGURE P-2. Technology Study Organization

# **Fiber Optics**

## **OSD Study for Improving Weapon System Reliability and Maintainability**

**Report of Fiber Optics Working Group  
(Executive Summary)**

**July 1983**

**Andrew S. Glista, Chairman  
Naval Air Systems Command**

**Rodney S. Katz, Co-Chairman  
Naval Avionics Center**

## FOREWORD

The application of fiber optics within the telecommunications industry has seen dramatic advances during the early 1980's. Despite early military support for fiber optic research and development, application of this technology in military systems has lagged those in the commercial arena.

This report presents the findings of the Fiber Optics Working Group of the OSU sponsored study for improving the material readiness posture of the DoD. Fiber optics, as a new technology, was examined to determine its potential to improve the reliability and maintainability of military systems.

The working group, consisting of twenty-nine members from government and industry, devoted their time and efforts to assessing the state of the art of fiber optics, identifying critical issues preventing military applications of this technology, and developing recommendations for continued military development of fiber optics.

The chairmen sincerely appreciate the dedication and perseverance of the working group members. It is hoped that this report will be a catalyst for implementation of fiber optics within the military to achieve the benefits of enhanced performance and readiness that this revolutionary technology promises.

  
Andrew S. Glista, Jr., Chairman

  
Rodney S. Katz, Co-Chairman

## Fiber Optics Working Group

Andrew S. Glista, Jr., Chairman  
Naval Air Systems Command

Rodney S. Katz, Co-Chairman  
Naval Avionics Center

Larry Abernathy  
ITT, Electro Optics Products Division

Claud N. Bain  
Consultant

Robert Baumbick  
NASA Lewis Research Center

Albert Bender  
Fiber Com, Inc.

Robert Betts  
IRM Federal Systems Division

J. Robert Biard  
Honeywell Optoelectronics Division

Joseph Bucaro  
Naval Research Laboratory

Robert Gallawa  
National Bureau of Standards

Roger Greenwell  
Naval Ocean Systems Center

Paul Hallowell  
ORI, Inc.

Charles Hurwitz  
Lasertron, Inc.

George Kaposhilan  
Hewlett Packard Co.

Charles Kleekamp  
MITRE Corporation

Robert Kochanski  
Naval Ocean Systems Center

John Kolling  
Sperry Univac

Henry Kressel  
E. M. Warburg Pincus & company  
(formerly with RCA, David Sarnoff  
Research Center)

Owen Mulkey  
Boeing Aerospace

John R. Peronnet  
Grumman Aerospace Corp.

Richard Plunkett  
Western Electric

Howard E. Rast  
Naval Ocean Systems Center

Donald Reis  
Grumman Aerospace Corp.

Paul Sierak  
Rome Air Development Center

George Sigel  
Naval Research Laboratory

Ronald Solomon  
McDonnell Douglas

Larry Spencer  
NASA Langley Research Center

Russell Stanton  
Army Applied Technology Lab

Howard Wichansky  
U.S. Army CECOM

# FIBER OPTICS TECHNOLOGY WORKING GROUP REPORT

## PART I--EXECUTIVE SUMMARY

### Table of Contents

	<u>Page</u>
THE ISSUE: Fiber Optics and Readiness . . . . .	ES-1
THE CONTEXT: Concept and Organization . . . . .	ES-1
THE FOCUS: The Fiber Optic Contribution . . . . .	ES-1
THE OBJECTIVES: The Scope of the Study . . . . .	ES-1
THE TECHNOLOGY: Background and Definition . . . . .	ES-2
Background . . . . .	ES-2
Definition . . . . .	ES-2
THE FIBER OPTIC ADVANTAGE . . . . .	ES-6
Benefits . . . . .	ES-6
THE AREAS OF IMPACT . . . . .	ES-8
THE KEY APPLICATION AREAS . . . . .	ES-9
Fiber Optic Interconnects for High Speed Logic Circuits . . . . .	ES-9
Fiber Optics in Security Applications . . . . .	ES-9
Fiber Optics for Improved Reliability, Survivability, Shielding Effectiveness and Safety . . . . .	ES-10
Fiber Optics in Combination with Optical Sensor Technology for Advanced Sensor Systems . . . . .	ES-11
Fiber Optics as a Tool for Weapon System Integration . . . . .	ES-11
Fiber Optics as an Architectural Tool . . . . .	ES-11
TECHNOLOGY INTERRELATIONSHIPS . . . . .	ES-14
VHSIC . . . . .	ES-15
Structural Composites . . . . .	ES-15
Integrated Systems of Manufacturing . . . . .	ES-15
Cabling and Connectors . . . . .	ES-15
CAD/CAM . . . . .	ES-16
Electronic Packaging . . . . .	ES-16
Directed Energy . . . . .	ES-16
Artificial Intelligence . . . . .	ES-16
Non-Destructive Evaluation . . . . .	ES-17
Power Supplies . . . . .	ES-17
Testing Technology . . . . .	ES-17
Mechanical Systems Condition Monitoring (MSCM) . . . . .	ES-18
Manpower and Training . . . . .	ES-18
CONCLUSIONS . . . . .	ES-19
RECOMMENDATIONS . . . . .	ES-23

\*Part II, the main report, is published under separate cover.  
Reference IDA Record Document D-33 (Part II).

EXECUTIVE SUMMARY

List of Illustrations

<u>Figure No.</u>		<u>Page</u>
ES-1	Fiber Optics Point-to-Point Communications Systems . . . .	ES-4
ES-2	Basic Coupling Methods for Fiber Optic Bus . . . . .	ES-7
ES-3	WDM Systems Configurations . . . . .	ES-13
ES-4	Measure of Effectiveness Model . . . . .	ES-20

## EXECUTIVE SUMMARY

### THE ISSUE: FIBER OPTICS AND READINESS

### THE CONTEXT: Concept and Organization

The operational readiness of military systems, the ability to deploy effectively and employ all elements without delay, have been the subject of intense scrutiny in recent years. Readiness is an extremely complex factor which takes into account the reliability, operability, and maintainability of our systems as well as the training level of our personnel.

The Under Secretary of Defense has initiated a Joint OSD-Service-Industry study for improving weapon system reliability and maintainability (R&M). The objective of the study is to identify and provide support for high payoff actions by DoD to improve the military system design, development and support process in the areas of reliability and maintainability through innovative uses of advancing technology and program structure. In this context, fiber optics was scheduled as one of 16 technologies which could impact seriously the readiness of military systems.

### THE FOCUS: The Fiber Optics Contribution

At issue in the fiber optics context are essentially two questions:

- What is the potential contribution of fiber optics to operational readiness?
- Where do the fiber optics contributions fit into the overall integration of the new technologies?

### THE OBJECTIVES: Scope Of The Study

In an attempt to focus on these critical questions, the objectives of this study are two-fold:

- To determine and define the contribution that fiber optic technology can make to the operational readiness of military systems.
- To enumerate the requirements that must be satisfied and the sequence of developments that must occur before the use of fiber optic technology can increase military operational readiness on a routine basis.

This study identifies the improvements in operational readiness possible in the utilization of fiber optics in military systems. The methodology includes

case studies on the application of fiber optics to date (both commercial and military); detailed technical assessment of fiber optic components and systems; and an analysis of technical management, financial implications, and political impediments to the utilization of this technology. Conclusions and recommendations are presented which will assist DoD in the transfer of fiber optic technology into military systems.

## THE TECHNOLOGY: Background and Definitions

### Background:

The current methods for military-guided data transmission (twisted shielded pair (TSP) wire, coaxial cable, and waveguide systems) are an essential component of all modern weapons systems.

Requirements for data transmission have increased dramatically in complexity with the rapid infusion of digital integrated circuits and the need to transfer data in real time. With this increase in complexity, the reliability and maintenance problems associated with electronic cables have increased significantly. For example, estimates state that aircraft wiring failures constitute about one-third of the total failures in military aircraft. Use of fiber optic technology to eliminate these problems would have a significant effect on operational availability of all military systems and result in potential savings of billions of dollars over the service life of these systems.

Fiber optics technology is currently receiving much attention as a new "high-tech" industry. The transmission of data via optical fibers represents a technological breakthrough. Fiber optics is rapidly becoming a commercial reality as an option to the transmission media of copper and radio waves. In addition, the use of fiber optics for sensing also provides a breakthrough in the sensitive measurements of physical phenomena. The use of this technology for both data transmission and sensing has not received widespread use in military systems.

The commercial telecommunications industry, both domestic and foreign, has made the financial and technological commitment to incorporate fiber optics into existing networks and planned expansions. The military, however, has only realized a limited use for the technology, although the potential benefits in system performance and life cycle costs for the military are commensurate with those in the commercial sector.

### Definition:

Fiber optics is guided light transmission of signals by means of optical fibers. With optical fibers, data transmission systems, sensors and optical processing devices can be developed. Information converted to optical form is transmitted through transparent (usually glass) fibers. Two basic data transmission systems exist: point-to-point data link and multi-terminal data bus. The following discussion identifies the functional elements of these basic systems.

<sup>1</sup>Rodney S. Katz, Airborne Fiber Optics, Naval Air Systems Command (AIR-514) Technology Advances Newsletter, June 1982



## A. Fiber Optics System (Point-to-Point)

The basic elements of a fiber optics point-to-point communications system are illustrated in Figure ES-1.

### 1. Transmitter

The fiber optics transmitter accepts the electrical signal, converts it to optical form and couples it to the fiber optics cable. The transmitter elements and their functions are as follows:

Signal Shaper/Encoder - The signal shaper circuit element is the primary interface between the host electronics unit or other source of electrical input signal. This circuit provides any necessary signal shaping or encoding for either analog or digital optical signals.

Digital signaling predominates in modern weapons systems. The electrical signal in digital form (TTL or ECL logic level) may be used to directly modulate the source driver circuit. In other applications the digital input signal may be encoded in the form of a digital multiplex signal employing time division multiplex (TDM), pulse code multiplex (PCM), or any other technique used for encoding.

Source Driver - The source driver is the circuit that directly drives (and modulates) the optical source element. This circuit may vary considerably in complexity depending on the type of modulation and speed (bandwidth) required. In its simplest form the source driver might be a single transistor switch. In more complex form it might include circuit elements to increase switching speed (pulse circuits) or bandwidth (analog circuits). Complex circuits may include sensing and control (stabilization) of the optical output power.

Optical Source - The optical sources most often used for fiber optics communications systems are the light emitting diode (LED) and the injection laser diode (ILD). These are solid-state junction devices which emit optical energy in response to an input current. Most military experience is with devices fabricated in Gallium Arsenide (GaAs) or Aluminum Gallium Arsenide (Al<sub>x</sub>Ga<sub>1-x</sub>As). These devices emit in the near infrared range of approximately 780-900 nanometers, depending on the proportion of aluminum present. For short distance applications these are often the best choice. For long distance applications (land-based, undersea), long wavelength sources are preferred (1000-1600 nm). Long wavelength optical transmission minimizes pulse dispersion in cable thereby providing wider bandwidth/increased channel capacity. Long wavelength sources use quaternary materials such as Aluminum Arsenide Gallium Phosphide. Experience with long wavelength devices indicates potential increased operating lifetime over 780-900 nm sources. Most commercial applications use nonhermetic sources; most military applications require hermetic source packaging. Hermetic source packaging is necessary for severe environment platforms such as aircraft and ships and for tactical ground equipment. The LED is preferred over the laser diode as a source for severe platform applications. The laser diode is more complex and costly and cannot operate over the broad temperature range required for these systems unless

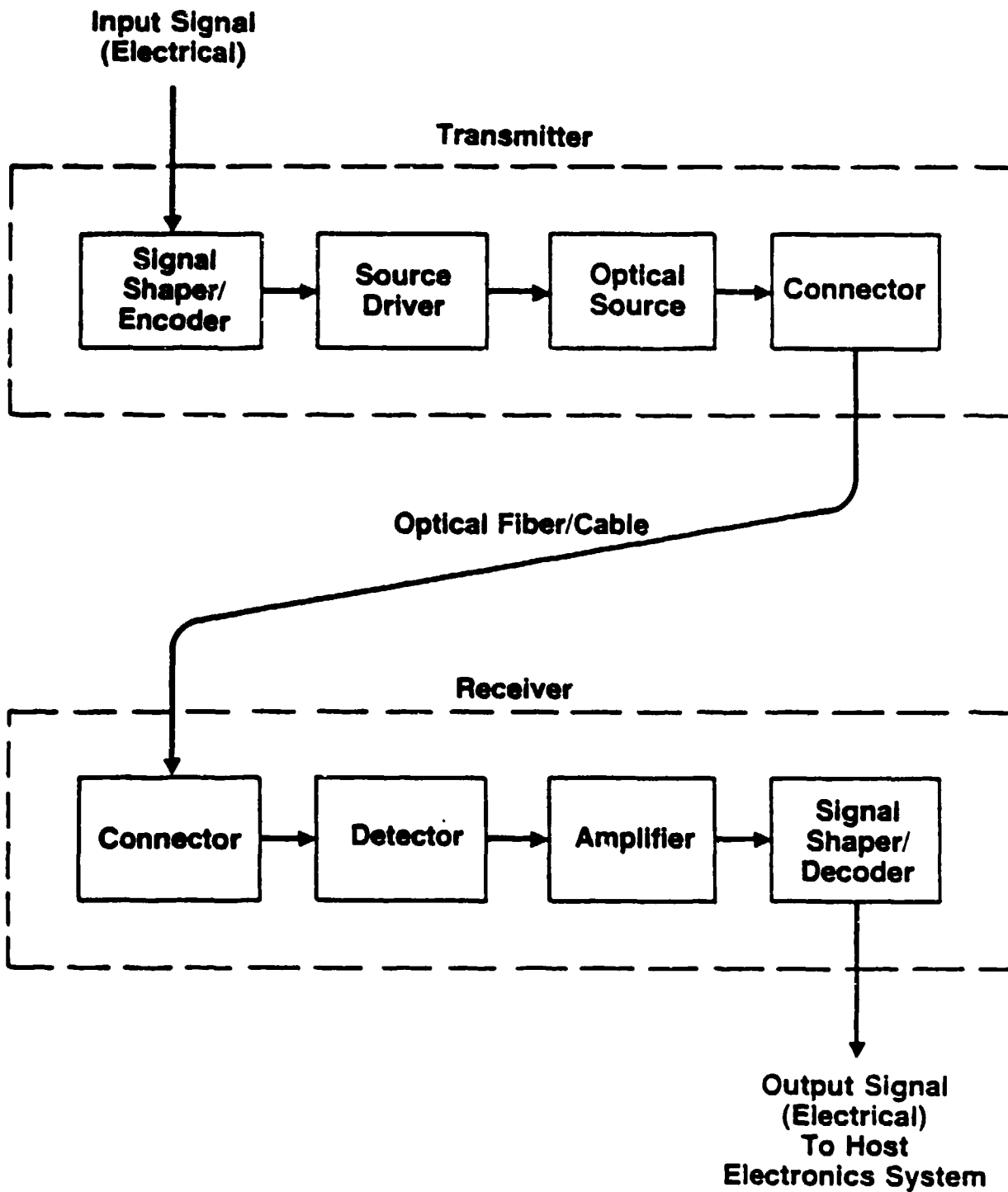

Figure ES-1. Fiber Optics Point-to-Point Communications Systems

they are cooled. The laser diode may be required for those platform applications where the bandwidth/speed or radiant power output of the LED are insufficient. For long distance applications laser diodes are usually necessary to provide sufficient optical power and achieve maximum channel capacity.

Connector (Source-to-Fiber) - The last important transmitter element is the connector (or coupler). This device provides for efficient coupling from the source to the transmission element -- the optical fiber/cable.

## 2. Optical Fiber/Cable Assembly

The optical cable transmits the optical signal from the transmitter to the receiver either over a single fiber channel or over a bundle of fibers which collectively serve as a single channel. Technical requirements are concerned with channel loss (attenuation) and channel bandwidth. Other parameters of concern include connector/coupling efficiency, cable strain relief and general cable survivability in a stringent environment.

## 3. Receiver

The fiber optics receiver accepts the optical signal, thereby completing the link. Within the receiver the optical-to-electrical signal conversion is performed and any necessary amplification, demodulation and/or decoding is performed. Receiver functional elements are the following:

Connector (Fiber-to-Detector) - The receiver connector provides efficient/reliable coupling from the transmitting fiber/cable to the optical detector.

Detector - The detector must be able to convert the optical signal to an electrical signal while retaining amplitude and frequency information. Solid-state detectors are most suitable for military systems. FN and PIN photodiodes of silicon are most frequently used for short distance applications. Silicon detectors are spectrally compatible with optical signals in the 700 to 900 nm wavelength range; Germanium and quaternary detectors are used for long wavelength systems. Avalanche photodiodes (APD) are required for long distance systems to increase receiver signal sensitivity.

Amplifier and Signal Shaper/Decoder - The amplifier and signal shaper/decoder circuits constitute the remainder of the receiver signal processing electronics. The amplifier enhances the electrical signal generated by the detector in response to the optical signal and increases it to a level at which it can be processed (shaped/decoded) suitably for coupling to the host system electronics unit.

## B. Fiber Optics System - Data Bus

One of the modes of application which primarily distinguishes fiber optics applied to weapons systems is the multiple terminal access system, or data bus. In data bus applications, significant differences between optical and electrical distribution systems become apparent. The most significant present-day avionics data bus system is that described by MIL-STD-1553A/B. This bus utilizes a "party line" linear bus structure with transformer coupling to a

twisted shielded pair transmission system. Each terminal is buffered from the transmission line by the impedance transform properties of its electrical transformer. As a result, a large number of terminals can be interfaced to the bus without serious distortion or attenuation of the signal waveform.

Figure ES-2(a) shows a fiber optics bus coupled in a similar fashion. This linear bus structure requires the use of tee couplers. Because of the inefficiencies of tee couplers, such a bus can accommodate only a few terminals before the power from a single source (LED or laser diode) is diminished below a practical lower level.

Figure ES-2(b) presents a data bus topology which is particularly effective for an optical bus. This topology features a central star coupler as the distribution element. A signal from any of the system terminals is distributed to all of the system terminals. For an "N" port system the star coupler provides a  $1/N$  power division to each of the terminals. Because of the signal equalization inherent in this topology, the star connected optical bus is far superior to the linear optical bus system.

In practice, a given avionics system topology might include both Star and Tee-coupled bus structures configured to optimize a complex system architecture.

Tactical ground-based systems may employ data buses but more often they will utilize point-to-point links. Often, tactical system terminals will be interconnected to provide a local area network (LAN) topology.

## THE FIBER OPTIC ADVANTAGE

### Benefits:

As we enter the information age, fiber optics provides unique benefits: invulnerability to EMI/EMP, expanded capabilities, physical property advantages and potential synergistic relationships with other technologies.

The foremost performance advantage is a total immunity to electromagnetic disturbances. Since the transmission path is dielectric (glass or fused silica) total electrical isolation is achieved along the transmission line. Cross talk (interference) between a pair of parallel transmission lines is totally eliminated. Shielding between parallel transmission lines is inherent and requires no metallic sheath.

The high degree of isolation between electrical interface circuits and the optical transmission line eliminates the need for coupling transformers and other elaborate impedance matching/shielding techniques. Pulse transmission exhibits no pulse "ringing" or severe attenuation problems characteristic of electrical transmission lines. Total electrical isolation eliminates ground coupling problems by effectively "opening" the ground loop circuit. Because of the nature of optical transmission, the fiber optics cable is totally immune to the high intensity electric fields generated by electromagnetic pulse (EMP). Associated with the dielectric nature of the optical transmission line is the corollary advantage of nondestructive short circuits with the elimination of spark/fire hazards.

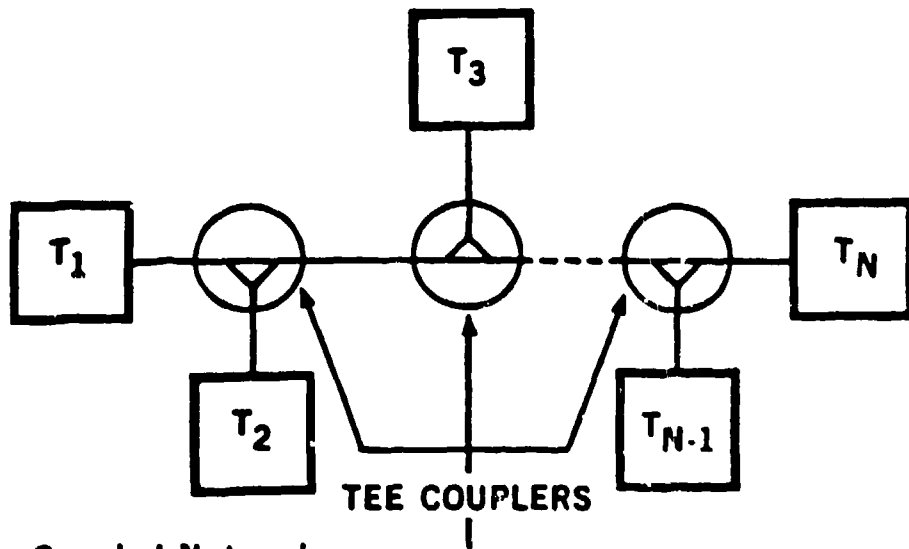

(a) Tee-Coupled Network

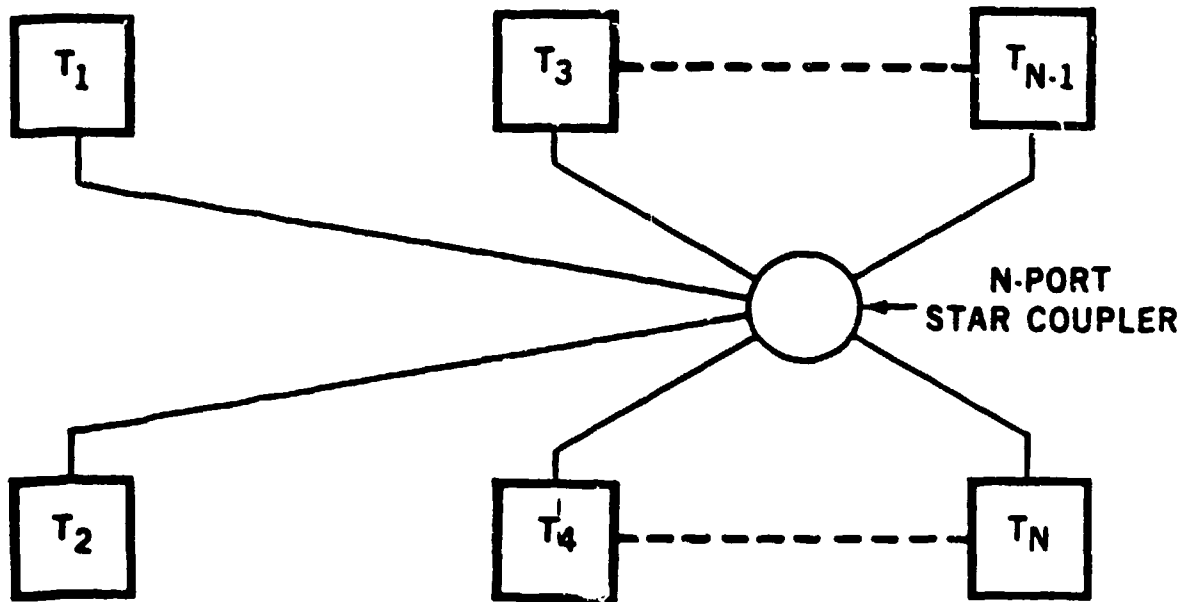

(b) Star-Coupled Network

Figure ES-2 Basic Coupling Methods for Fiber Optics Bus

An additional benefit is the high temperature capability of fiber optics (glass and fused silica types). This capability provides potential use in routing through engine compartments and other high temperature service regions.

A major benefit offered by fiber optics is the bandwidth potential and the consequent high data rate transmission. Data rates far higher than those normally feasible with twisted shielded pairs electrical transmission lines can be implemented in a relatively simple manner with fiber optics. In comparison with wide bandwidth electrical transmission lines, such as coaxial cable, fiber optics provides a much higher communications capacity for both analog and digital data transmission on a very small optical fiber.

When special optical multiplex techniques are employed, the information capacity is increased dramatically. Wavelength division multiplex is a technique where several optical messages, each assigned a separate optical wavelength, can share the same optical fiber simultaneously. This particular advantage can be used for both point-to-point links and data buses.

#### AREAS OF IMPACT:

The characteristics of fiber optics transmission systems can impact future military systems significantly. The primary areas of impact are the following:

1. Invulnerability to EMI and EMP
  - Electrical isolation
  - Increased safety
  - Nuclear radiation resistance
  - Lightning strike immunity
  - Increased information security
  - Solution to TEMPEST requirements
2. Expanded Capacities
  - Multi-terminal network capabilities, hierarchical data bus systems, expanded capability communications networks, expanded capability local area networks (LAN)
  - Increased bandwidth/very high data rate
  - Increased communication channel capacity
  - Extremely low transmission loss
  - Low error rates
3. Physical Characteristics
  - Weight reduction
  - Size and volume reduction

- High temperature capabilities
- Stringent environment capabilities

4. Synergistic Relationships With Other Technologies to Provide the Following

- Increased system effectiveness/availability/operational readiness
- Survivability
- Reliability
- Maintainability

KEY APPLICATIONS AREAS

Certain key application areas focus the advantages of fiber optics for a major impact on military systems. Military applications cover a host of diverse environments, such as aircraft platforms, tactical ground arenas, strategic or fixed environments, shipboard and space environments. Within each area the environmental conditions and system constraints establish the priority of the various fiber optic advantages. Several key application areas are discussed below:

• FIBER OPTICS INTERCONNECTS FOR HIGH SPEED LOGIC CIRCUITS

Fiber optics can be used as an intra-system interconnection technology to provide high speed signal transfer between VHSIC/VLSI OR GaAs integrated circuits.

One form of interconnection will provide signal transfer from chip-to-chip on the circuit board or "module". Another form of interconnect is module-to-module as a form of "backplane" signal transfer. Both forms can be combined for maximum effectiveness in realizing the capability of VHSIC or GaAs circuitry.

In any form of interconnect, discrete optical fibers are physically compatible with wire wrap and multiwire wiring techniques currently used as backplane wiring on conventional circuit cards. The fiber optics replacements for wirewrap would be highspeed and free from the interference/crosstalk problems of conventional wirewrap/multiwire techniques.

In addition, planar waveguide structures can also be used to interconnect logic circuits. These interconnections perform similarly but are fabricated by the thin film processes associated with hybrid circuit manufacture. Planar or "integrated optics" interconnects are particularly suited to short distance high speed information transfer between VHSIC or GaAs chips.

• FIBER OPTICS IN SECURITY APPLICATIONS

Enhanced electronic system security is a significant benefit anticipated from fiber optics. Of particular importance from an electronic system security viewpoint are fiber optic cabling, fiber optic coupling and fiber optic multiplex systems.

Present electronic data/signal routing within aircraft for both classified and unclassified signals uses conventional metal wiring. This hardware cabling requires extensive and cumbersome shielding to provide the TEMPEST protection required for the handling of classified electronic data/signals. Shielding is a particular problem on aircraft where extra shielding is required because the physical separation between the cables is very small. Fiber optics cabling offers a solution because of the inherent isolation provided between cables even in close proximity.

Similarly, TEMPEST-required isolation between and within electronic circuits and systems is particularly cumbersome using electronic hardware isolation techniques. Optical coupling techniques offer a solution to this problem because of the isolation provided in converting electronic data signals to/from the optical domain and the significant reduction in electronic/electromagnetic conduction through the coupling connector. Fiber optics multiplex systems can benefit electronic systems security in reducing the number of interconnecting circuits, thereby reducing TEMPEST vulnerability.

Wavelength division multiplex, which separates messages which share a common data bus by the use of several separate and distinct optical wavelengths, may also enhance message security in some applications.

\* FIBER OPTICS FOR IMPROVED RELIABILITY, SURVIVABILITY, SHIELDING EFFECTIVENESS AND SAFETY

This combination of factors, which provides a unique advance in system effectiveness, is not available with any other interconnection technology. Its use is most appropriate in military aircraft under severe environment, severe EMI/EMP threat. Several significant uses can be delineated:

1. Use fiber optics with composite skin aircraft (reduced shielding at certain frequencies) to solve shielding problems from EMI and to meet high system EMP shielding effectiveness requirements.
2. Use fiber optics for improved reliability because the small size of the fiber allows redundancy techniques not possible with conventional wiring.
3. Use fiber optics for improved survivability against battle damage. Where normal cable channel limits make it impossible to locate redundant cables in remote sections of the aircraft, the small fiber cable size allows easy routing to remote locations. Fibers may even be embedded in composite structural elements to provide easy interconnection between redundant channels.
4. Use optical fibers for routing near engine and other high temperature areas.
5. Use fiber optics in armament systems because its EMI invulnerability provides safety advantages and protects against accidental EMI generated weapon release.



° FIBER OPTICS IN COMBINATION WITH OPTICAL SENSOR TECHNOLOGY FOR ADVANCED SENSOR SYSTEMS

1. Provide reliable interference-free optical sensor information.
2. Combine many sensors to achieve enhanced microprocessor controlled sensor status monitor systems. Such systems can be integrated in flight controls, engine controls and similar systems.
3. Develop standardized optical bus data format and protocol to achieve integration of sensor data systems.
4. Use the optical sensor bus concept to expand avionics/data bus techniques into new areas.

° FIBER OPTICS AS A TOOL FOR WEAPON SYSTEM INTEGRATION

The full integration of subsystems into a weapon system has traditionally been time consuming and costly, particularly in platforms such as aircraft and ships. Subsystems, functionally described, are developed to individual subsystem specifications. When the full avionics or ships system integration takes place and the boxes are combined in a single airframe, however, many problems develop. Many of the problems are related to the complex electromagnetic environment created. This environment is dependent on the subsystems, their respective locations and interrelationships, physical location to aircraft power systems and distribution, the quality and location of the grounding system of the aircraft, and aircraft and subsystem shielding. Many of the integration problems can only be solved by extensive labor-intensive engineering design to incorporate shielding design, redesign and extensive testing. Many cost over-runs in aircraft development are attributable to electromagnetic compatibility (EMC) problems associated with avionics integration. Fiber optics provides sufficient isolation between avionics subsystems to eliminate the EMC problems of integration.

° FIBER OPTICS AS AN ARCHITECTURAL TOOL

Military avionics systems epitomize complex architectures. Because of its high speed/protected information transfer, fiber optics offers a unique capability to interconnect complex weapon systems. The development and acceptance of MIL-STD-1553B, the avionics data bus standard, allows combination of many subsystems into a fully integrated avionics system. MIL-STD-1553B is primarily a command/response bus which provides the control functions of an integrated avionics system. Although it does provide for data transfer, its bit rate of 1 MB/s is severely limited to address the information transfer needs of many modern avionics systems.

The need for high speed data buses (10-100 MB/s) for avionics is being considered by both the Air Force and Navy. The Air Force PAVE PILLAR program is a major program effort to define the architectural needs of modern avionics systems. Within the Air Force the first hardware development is for the ICNIA (Integrated Communication, Navigation and Identification Avionics) program. A similar program underway in the Navy which predates ICNIA is the TIES (Tactical Information Exchange System). Although fiber optics is being considered for these system developments, it is not being emphasized.

Fiber optics is the transmission technology of choice for advanced avionics system architectures. Most architectures proposed for advanced avionics systems are hierarchical, effectively combining a number of separate data buses and wideband signal processing links. Fiber optics offers unique advantages for this purpose.

To key this application, fiber optics must be considered from inception because of the special design rules for fiber optics which favor certain system topologies. Fiber optics retrofit into a concept designed for conventional wiring will always provide limited performance.

In addition, Wavelength Division Multiplexing (WDM) offers unique capabilities when applied to advanced avionics architecture needs. WDM involves the simultaneous transmission of information via different wavelengths of light. The various wavelengths, after generation by separate optical sources, are mixed by a multiplexer and transmitted over an optical communication link. At the receiving end of the link, the distinct wavelengths of light are separated by a demultiplexer and converted to electrical signals by a photodetector. By using WDM a single optical fiber will provide multiple transmission paths. WDM increases the information capacity of a single optical fiber and also provides a means for two-way simultaneous transmission (full duplex). For a given data transmission requirement, a WDM system would require fewer optical fibers, repeaters, splices and/or connectors than a single wavelength system. Figure ES-3 illustrates a unidirectional WDM system of N wavelengths and also WDM as applied to bidirectional transmission.

Using WDM, several optical buses could share the same transmission medium, each assigned a distinct wavelength. In this manner the MIL-STD-1553B command/response bus and several high speed buses could be combined providing one access port to each subsystem, thereby significantly reducing interface I/O problems.

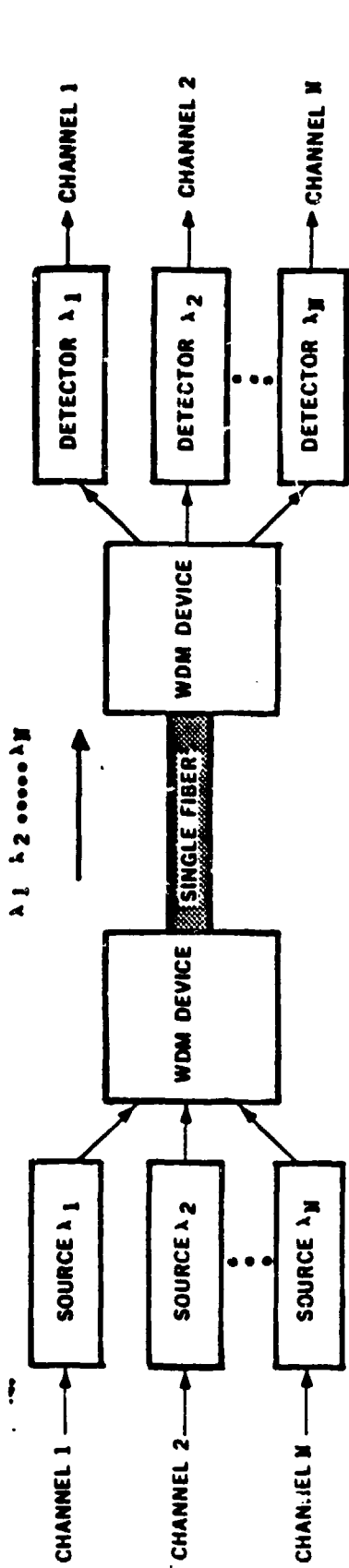

(a) A unidirectional WDM system that combines  $M$  independent input signals for transmission over a single fiber.

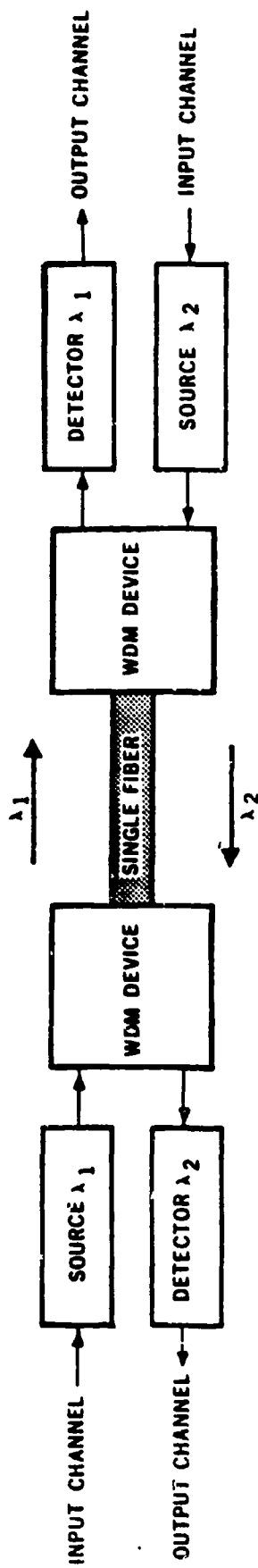

(b) A bidirectional WDM system in which two or more wavelengths are transmitted simultaneously in opposite directions over the same fiber.

Figure ES-3 WDM Systems Configurations 2

2 Gerd Keiser, "Optical Fiber Communications", New York: McGraw-Hill, 1983, p 221, and p 222.

## TECHNOLOGY INTERRELATIONSHIPS

Fiber optics significantly interrelates to most of the technologies involved in the study. These interrelationships vary; their nature reflects the breadth of possibility in fiber optics.

Just as the introduction of integrated circuits has burdened the capabilities of existing data transmission technology, the infusion of other advanced technologies in military systems can pose readiness problems if potentially synergistic relationships (program-wide, positive or negative) are not recognized early in the development cycle.

Historical precedent is useful in this respect. Integrated circuits were introduced into strategic systems before nuclear radiation effects and long term failure mechanisms were totally understood. A similar potential danger exists as VHSIC and high speed Gallium Arsenide circuits are introduced into military systems. These high speed, low voltage, radiation-hardened circuits will require a high speed transmission media. If copper is used, EMI/EMP susceptibility may negate the intrinsic hardness of the circuitry. The lower voltage swings, along with simultaneous introduction of composite materials in fighter aircraft and missiles (i.e., STEALTH) will only complicate the problem. Electrical multiplexing is increasingly being used to reduce the number of cables and connectors. This trend toward fewer data links for weapons system integration poses potential vulnerability problems if the links are susceptible to natural (lightning) or man-made (nuclear and non-nuclear) transient upset. Optical transmission alone can provide simultaneous solutions to all of these problems potentially affecting the readiness of our newest systems.

The development of integrated circuit technology can serve as a model for fiber optics technology development. The integrated circuit development dealt with the following elements:

- Technology base support has been constant and is accelerating even with a large commercial market.
- Systems demonstrations have been performed and continue to be supported (e.g., VHSIC brassboards).
- A major reliability program was initiated in 1969 with DARPA, Tri-Service, and NBS participation.
- A single focal point has existed in DoD for this technology (OUSDRE).
- Specifications and Standards have been developed.
- A Qualified Parts List exists.
- Multiple sources of components are available commercially.
- Policy guidelines exist for utilization of this technology.
- Major test facilities for components are available (e.g., RADC).
- Industry/academia cooperatives have been formed to sustain our technology base against foreign competition.
- ILS support programs are in use for this technology.

Corresponding efforts in fiber optics can result in similar widespread use in military systems. Examining aspects of the 16 technologies identified for this study in terms of this historical perspective reveals their positive interrelatedness.

#### • VHSIC

The use of fiber optics as a high speed, interference free interconnection technique for VHSIC chips is presented elsewhere in this paper as a key application area.

If this concept is fully developed, the potential exists for an optical multiplex data bus to interconnect VHSIC chips. This data bus would operate on a chip-to-chip level. Because of the high circuit density of VHSIC chips this bus would approximate current data buses which interconnect avionic subsystems. The development of a "mini" optical data bus for VHSIC at data rates of 100-500 Mb/s would provide signal multiplexing to enhance the capabilities of VHSIC. Standardization of a high speed VHSIC chip input-output (I/O) optical interface will promote more efficient use of VHSIC capability.

#### • STRUCTURAL COMPOSITES

Fiber optics compensates for deficiencies in composites' shielding. The survivability of information transfer in composite structures is enhanced by fiber optics. The electrical distribution/grounding system requirements in composite structures are simplified with the use of fiber optics. Fiber optics embedded in composite structures can monitor strain, and can, therefore, contribute to materials research and analysis. Real time diagnostics of composite structures in operational systems can also be provided by embedded fiber optics strain monitors.

#### • INTEGRATED SYSTEMS OF MANUFACTURING

In the future, robots will be used for many DoD applications ranging from automated manufacturing to direct maintenance and support of military systems in the field. In industrial environments, the electromagnetic noise immunity of optical data transmission allows noise-free control of robots. As robots are adapted to more challenging applications the requirement for improved sensing capabilities will increase and robot failure backup will need to be addressed. Optical sensors, with their precision and noise immunity, are natural choices for this application.

#### • CABLING AND CONNECTORS

Because of the electrical isolation provided, fiber optics will eliminate the need for some filter pin connectors. Fiber optics offers a solution to corrosion problems. Corrosion at the contact is not a problem for optical interconnects; corrosion of the shielding is also not a problem, since metallic shielding is not required for signal protection.

The wide bandwidth/high speed capability of fiber optics encourages high data rate/multiplex applications. In turn, the number of contacts and connectors required is reduced, improving reliability.

#### • CAD/CAM

Fiber optics as a technique for signal transfer is well defined and understood. The maturation of the component technology provides a significant component selection to optimize system analysis and design. Design rules for fiber optics applications exist and can be codified for application to CAD.

CAM procedures, however, are largely unexplored at the system level. The work on process control for fiber manufacture has been key to the production of strong, consistent, close tolerance fibers and cables. The Bell system has implemented CAM procedures consistent with their volume usage. As the military applications develop resulting in increased requirements for stringent environment/increased performance devices, the consistent application of CAM techniques will be required to ensure a reliable, cost effective product.

#### • ELECTRONIC PACKAGING

Fiber optics has an important role to play in the evolution of advanced electronics packaging concepts. Problems inherent in signal protection are extremely important in the planning of advanced packaging systems. Fiber optics and planar, guided wave optics provide the capability for advanced packaging without the weight and configuration burdens of additional shielding. Packaging concepts require simultaneous consideration of fiber optics capabilities and concerns.

#### • DIRECTED ENERGY

Considerable cabling is required for signal processing and information transfer in Directed Energy support systems. The superior bandwidth/EMI rejection capabilities of fiber optics can reduce the cabling in the weapon control system. In passive countermeasures for Directed Energy Weapon systems, optical fibers present a very small cross-section. Fibers, therefore, can be used to advantage in redundant cabling applications to enhance survivability.

In addition, fiber optics fails "safe." No spark/short circuit hazard exists. A system then is protected from secondary failure modes when a cable is severed by a Directed Energy system.

#### • ARTIFICIAL INTELLIGENCE

Artificial Intelligence (AI) in the Readiness Study has been explored for potential advantages to testing applications, specifically to Built-In Test (BIT) aspects. For this application fiber optics offers the following:

- Reduced "false alarm" rate because of EMI immunity
- Simplified information transfer interface.

Artificial Intelligence also has application to real time weapon system management. In complex avionics associated with tactical aircraft, AI can partially relieve some cockpit management/decision processes. In this application fiber optics provides the following:

- Wide band signal processing and high data rate information transfer with EMI/EMP immunity
- Small size and simplified interconnection to exploit high density logic/memory circuits

#### • NON-DESTRUCTIVE EVALUATION

Fiber optics can be used in several ways for Non-Destructive Evaluation (NDE). One technique makes use of optical fibers embedded in composite structures to detect structure stress. This technique is applicable to laboratory development as a research tool but can also be used for real time monitoring on operational systems.

Epoxy-coated fibers have been developed which are strong and are compatible with this application. The development of multi-core optical strain sensors provides strain monitoring capability at precise locations within composite structures.

Similarly, acoustic, magnetic and amplitude fiber optic sensors can be used for NDE. Many parameters can be sensed including pressure, temperature, linear and angular position, strain, acceleration, rotation rate, liquid level, flow rate and others. Important features particular to fiber optics include electrical isolation, high sensitivity, small size and high temperature operation.

One specific application of fiber optics to NDE is the viewing of otherwise inaccessible areas for maintenance evaluation. For example, on aircraft wings, periodically the outer "skin" is removed so that wing interiors can be checked for corrosion. The use of remote controlled fiber optics probes could be used to perform this otherwise costly NDE in remote wing areas.

#### • POWER SUPPLIES

Optical isolation techniques have been used for some time for increased electrical isolation in power supplies. The opto-coupler is a miniature optical transmission system containing a source and detector packaged together. Use of opto-couplers in power supplies and power distribution systems eliminates the need for a common ground by effectively isolating the source and detector sections. Fiber optics links perform the same function as the opto-coupler but use of the optical fiber provides for a longer optical isolation path and therefore more effective electrical isolation.

Optical links which couple control signals to remote power controllers and power sensors can provide electrical isolation and consequent additional safety for this application. Both fiber optics links and opto-couplers can be used in power distribution systems for signal isolation to minimize filtering and filter pin connector requirements.

#### • TESTING TECHNOLOGY

There are many uses of fiber optics and fiber optics sensors to support military testing technology concepts. Optical sensors have many applications for embedded test support because of their small size, electrical isolation

and wide temperature range operation. These sensors integrated into a network of sensing elements can provide advantages for an embedded diagnostic/prognostic capability unaffected by EMI concerns. The wide bandwidth of the optical medium provides for complex diagnostics not limited by information transfer constraints.

One specific application of fiber optics is the measurement of small signals in very intense electrical fields, characteristic of EMP/EMI testing and qualification programs. One program which uses fiber optics for this purpose is the Navy FAANTAEL program (Fleet Aircraft Assessment Navy Test and EMP Limitations). In conducting EMP/EMI testing FAANTAEL has made extensive use of fiber optics communications links. Both aircraft and missiles are tested under simulated EMP/EMI/lightning strike conditions. Output signals from the systems under test are monitored before, during, and after the test. The tests show optical signal transfer unaffected by the intense electric field environment. Fiber optics systems are available with the advantage of bandwidth up to 500 MHz. As a result many more test points can be monitored for each test, reducing test time and costs dramatically.

#### \* MECHANICAL SYSTEMS CONDITION MONITORING (MSCM)

Fiber optics and optical sensors support MSCM in a number of ways. One example is the use of fiber optics for an optical tip clearance sensor. This sensor is intended for application in electronic propulsion control systems for aircraft. A research program was conducted for the NASA Lewis Research Center, Cleveland, Ohio to analyze and evaluate this application.<sup>3</sup> This and other MSCM applications make significant use of the electrical isolation properties of fiber optics.

#### \* MANPOWER AND TRAINING

The implications for manpower and training in fiber optics applications are dual. In the trend toward automation, the receding human factor requires the increasingly reliable testing methods of fiber optics. To complement the advantages inherent in the technology, experience has shown that only minimal training is required to employ fiber optics.

At McDonnell-Douglas with the AV8B and at Bell Labs in a commercial setting, an actual preference for fiber optics over coaxial cables was experienced. Fiber optics doesn't introduce excessive manpower or training requirements. Fiber optics presents only the training burden inherent in any new technology.

<sup>3</sup>G. L. Poppel et al, Analysis, Design, Fabrication and Testing of an Optical Tip Clearance Sensor, NASA CR-165265, May 1981



## CONCLUSIONS

### 1. Operational Readiness of Military Systems Can Be Significantly Improved By The Use Of Fiber Optics Technology.

Fiber optics can contribute significantly to improved operational readiness of military systems. Case studies for operational deployment in commercial and military systems exist and point to improved performance and reliability. Many well-documented case studies exist in the commercial sector. Richard Plunkett, Senior Engineer for lightwave technology at Western Electric, speaking for the Bell System experience, states: "Lightwave technology has been an unqualified success in terms of cost effectiveness and high reliability as applied to commercial telecommunications."<sup>4</sup>

The military experience has also provided a very positive impression of improved reliability combined with improved performance. Military applications paralleling the commercial telecommunications thrust are the most mature. Many of these applications utilize commercial telecommunications components which are ruggedized for military deployment. A number of tactical field communications systems are in advanced development by both the Army and Air Force. These applications feature ruggedized cables and connectors while using standard telecommunications fibers with 50 micron cores in a 125 micron cladding overall diameter. Field experience has been somewhat limited for these new systems but operational readiness improvements have been demonstrated through several factors. The optical fiber cables are much lighter weight and occupy significantly less space than the cables they replace. As a result, tactical field communications systems can be deployed much faster and often can be deployed from lightweight, handheld reels rather than heavy truck-mounted reels.

Experience has shown that maintenance of fiber optics in field deployable systems has presented no significant problems. The required repair and maintenance skills have been easily acquired by maintenance personnel. Maintenance capability is improved as part of an integrated logistics support effort.

Figure ES-4 presents a Measure of Effectiveness model for a weapon system. This chart puts in perspective many of the system characteristics and mission factors that influence system availability and readiness. These characteristics and factors are combined with mission success factors to demonstrate overall system effectiveness. In the context of this model, fiber optics offers many advantages. Essential invulnerability to EMI/EMP threats is vital for many platform applications. Fiber optics provides improved survivability for several reasons. In addition to improved EMI/EMP performance, the small size of the optical fiber easily allows increased levels of redundancy of communications channels even in small platforms. For example, the small size of optical fibers permits full quad redundancy in aircraft systems with sufficient physical separation to provide survivability from localized battle damage. Tactical

<sup>4</sup>Richard Plunkett, private correspondence to the OSD Fiber Optics Working Group, May 3, 1983

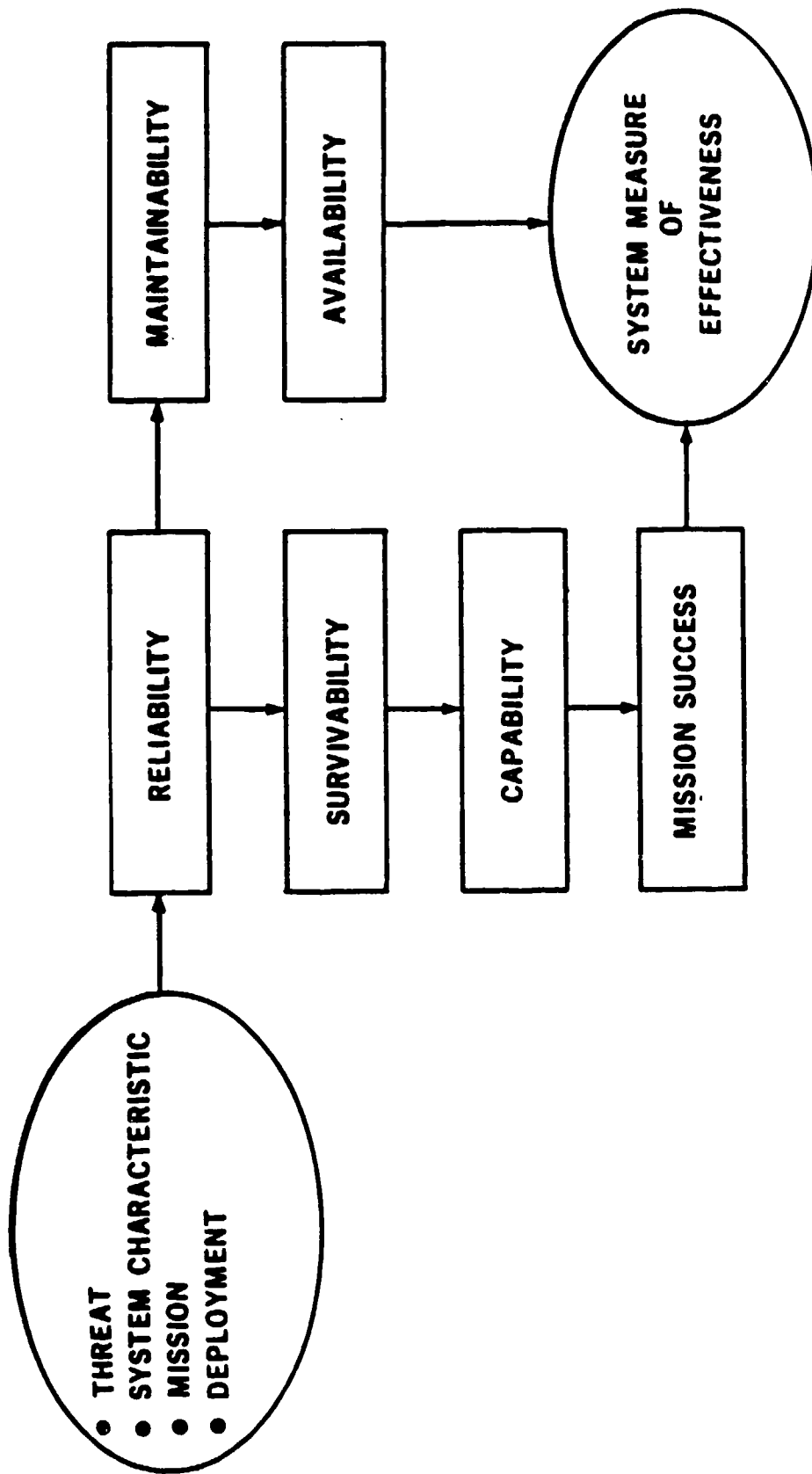

Figure ES-4 Measure of Effectiveness Model

ground survivability is improved significantly when radiation emitters, such as radios and radars, are moved away from operations centers. Fiber optics, because of low transmission loss and lightweight cable, makes increased separation between emitters and operation centers practical. Additional survivability capability is provided in the face of nuclear threats (ionizing radiation), because fibers have been developed which provide significant resistance to nuclear upset.

The enhanced capability of fiber optics for wide band/high speed signal transfer without interference provides for full use of modern high speed digital circuits such as those provided by VHSIC. The ability to transfer data at high speed enhances multiplexing capability and provides improved reliability through the use of fewer connectors and connector contacts. In summary, the capability provided by fiber optics assures that the reliability and survivability aspects of weapon systems will be vastly improved.

## 2. Reliability and Maintainability Improvements and Reduced Life Cycle Costs Have Been Demonstrated In Fiber Optics Telecommunications Systems.

The commercial telecommunication industry has made a major commitment to the utilization of fiber optics for future installations including trans-Atlantic links. The industry has made this significant investment in a radical departure from conventional data transmission media to fiber optics. Maintenance costs of existing telecommunications were rising at a rate of 17% per year in the Bell System, a reality which was instrumental in the decision to use fiber optics. The commitment has been more than justified by the inherent benefits of increased bandwidth, ease of installation (reduced size and weight), EMI immunity, and data security. Reliability and initial investment costs were secondary considerations. Performance results were remarkable. "Commercial telephone applications have an incredible track record of 40 million fiber-km hours with only one intrinsic failure." Western Electric feels that "Lightwave technology's impact may turn out to be comparable to that of the semiconductor and integrated circuit."

A specific study of fiber optic system life cycle costs by John Peronnet, Grumman Aerospace Corporation, cites reduced failure rate and corresponding reduction in total maintenance and depot personnel as significant savings in addition to savings at the initial investment level.

<sup>5</sup>Charles Kleekamp, MITRE Corp., private correspondence to the OSD Working Group, May 9, 1983

<sup>6</sup>Cohen and Snyder, The Western Electric Engineer, Winter, 1980, p 5

<sup>7</sup>John Peronnet, Life Cycle Cost (LCC) Savings Study of an Airborne Interconnect System, ILS Advanced Development, Grumman Aerospace Corp., May 14, 1983

### 3. The Military Has Not Yet Achieved Wide Scale Utilization Of Fiber Optics.

The military has applied fiber optics on a limited basis. Many of the successful applications closely parallel systems development in the commercial sector in long lines telecommunications. The component technology for these applications has been available essentially "off the shelf," adapted through the use of improved packaging and/or ruggedization for military use.

In applications for which commercial components are not suitable, very few operational systems exist. Ironically, these applications are among those for which the potential payoff in improved readiness and improved performance are greatest. Such situations include platform applications where severe environmental conditions are the rule and where potential EMI/EMP problems are very significant. Tactical ground applications requirements are also severe and are not satisfied by commercial components. This failure to apply fiber optics in severe environment applications is largely due to a lack of suitable components. The lack of components is directly traceable to the lack of a significant market as perceived by component manufacturers who are reluctant to provide the necessary investment to produce a superior class of components. Military high level planners in turn have assumed that the technology will develop as a matter of course, an assumption clearly based on the progress made in commercial applications. As a result, severe environment, high performance component development has been subject to low and inconsistent funding. No DoD full military commitment to fund the technology and establish a realistic program to make it happen has been forthcoming.

### 4. DoD Has Not Made A Full Program Commitment To The Development and Implementation Of Fiber Optic Technology.

To date, DoD has not provided a leadership position in the management of fiber optics vis-a-vis other technologies (i.e. VHSIC, laser gyros, software). While existing technology programs are well coordinated at the working level, the high level focused management associated with other high payoff technologies is absent. This absence of focused management has manifest itself in the following ways:

- Sub-threshold technology base funding
- Erratic advanced development funding
- Lack of support for developing Specs & Standards
- Absence of centralized test facilities
- Absence of a QPL
- Non-existent acquisition strategy and policy
- Underdeveloped ILS plans or programs.

A management focal point, sustained financial support and policy directives have not been provided to make fiber optics an "off-the-shelf" technology.

## RECOMMENDATIONS

The major recommendation of the working group is the following:

### Establish A DoD Wide Program Structure To Ensure That Fiber Optics Becomes The Standard Data Communications Media In Military Systems.

The present funding of fiber optics is fragmented and varies considerably from service to service. Applications of fiber optics suffer severely from low and inconsistent funding. Dangerous discrepancies exist when some of the highest payoff areas exist in severe environment platform applications and funding in those areas is almost non-existent.

A program structure modeled after the VHSIC program could provide high profile visibility and centralized DoD management as well as assuring the adequate, consistent funding necessary to achieve the full benefits that fiber optics can provide. Specific functions in this program structure involve the following:

- Coordinate system development activity. Insure that high payoff areas are clearly identified and properly funded.
- Provide Tri-Service wide funding for significant demonstration systems.
- Provide suitable 6.2 level funding "above the threshold" to assure that the appropriate component "tech base" is available to support the full scope of applications.
- Provide adequate funding for areas which traditionally are not funded until full scale implementation is underway. These areas presently roadblock the development of operational systems. Currently, the following are non-funded areas:
  - Specifications and Standards development
  - Full scale testing and qualification
  - Logistic support procedures and support/test equipment development.
- Implement necessary policy changes to ensure full effective use of fiber optics in military systems.

Since late 1981 the Tri-Service Coordinating Structure (TSFOCS) has taken a strong role in review of the fiber optics programs funded by the three services. TSFOCS annually reports its findings and recommendations to the Advisory Group on Electron Devices (AGED) and to OUSDR&E. The program structure required for fiber optics goes significantly beyond the advisory role presently provided by the TSFOCS. It is recommended that TSFOCS continue to review and advise the new fiber optics program management that is created or, alternately, that the new program management be provided by the TSFOCS with suitably enhanced authority and resources.

**SPECIFIC RECOMMENDATIONS:** Several specific recommendations are tied to critical areas of fiber optics system development and support. Adoption of these recommendations will facilitate the introduction of fiber optics technology into military systems with improved performance, reliability and maintainability.

1. Technology Base Funding Must be Adequate and Constant.

The technology base funding for fiber optics must be sustained at a level proportional to the payoff in order to achieve widespread utilization in military systems. The military investment to date helped to spawn the limited fiber optic component industry in the U.S. but has produced only a limited selection of components capable of meeting the needs of the full military environment. In the words of Michael Ettenberg, head of RCA's optoelectronic devices and systems, "Military contracts kept us alive" before the telecommunications market developed. Current economic conditions have encouraged conservatism on the part of industry managers in the development of military technology without an assured market. The military is surely less than a guaranteed market place.

A simultaneous conservatism on the part of military R&D managers because of the emphasis on near term acquisition of hardware has eroded the technology base support. Funding in this area should be sustained at about \$50M per year (combined cost in R&D, Independent R&D, and Manufacturing Technology) to assure multiple sources for militarized fiber optic components. Funding at this level generates continuity and competitiveness in the domestic fiber optic industry. Such funding would also help to regain the portion of this market which has been lost to foreign competition.

2. Technology Demonstrations and Advanced Development Must be Pursued.

Systems demonstrations have been a very effective means of introducing a new technology to acquisition managers. These demonstrations pinpoint deficiencies or confirm the adequacy of the existing technology base. A documented example was the A-7 ALOFT fiber optic demonstrations which highlighted the lack of "off-the-shelf" militarized components. Manufacturing technology efforts were implemented based on this experience, and components from these efforts later found use on the ground launched cruise missile. In 1982 Rome Air Development Center (RADC), Griffiss Air Force Base, New York, designed the Air Support Operations Center (ASOC) to permit the remoting of radio emitters. The ASOC is a tactical communications system comprised of a number of mobile shelters, which, when interconnected form an operations control center and radio network for communicating with airborne aircraft and other radio-equipped remote locations. Currently, the Army under the Advanced Digital Optical Control System (ADOCS) program is developing a demonstration system for primary optical control of a UH-60 Blackhawk helicopter. This system uses

<sup>8</sup>Michael Ettenberg, quoted in Washington Post article "In Laser Advances, An Orient Express," April 1983

redundant digital optical components and is scheduled for first flights in November 1984. This type of demonstration system should definitely continue in designated impact areas (e.g., high speed data bus, wavelength division multiplex, fiber optic sensor systems, optically guided weapons, others).

Funding for demonstration systems is dependent on the specific applications (e.g. aircraft, missile, ship, submarine, tactical ground equipment) and should accompany a sustained advanced development 6.3 program in each of the services.

### 3. A Qualified Parts List Is Imperative If This Technology Is To Become "Off-the-Shelf."

One of the reasons most often given for the failure to utilize fiber optics is the lack of a QPL (qualified parts list) for application. The absence of tested and qualified components has become a severe stumbling block since component manufacturers don't identify the military as a significant market. It is therefore incumbent on DoD to select components from the 6.2 tech base suitable for application and provide the resources to fully test and qualify them for military use.

Six activities should characterize this effort:

- Establish test procedures and qualification plans.
- Select components for qualification, with TRI-Service coordination to promote standardization.
- Develop Specifications and Standards.
- Conduct full testing programs.
- Evaluate test results and qualify suitable components.
- Establish and maintain a qualified parts list (QPL) of fiber optics components for military applications under Federal Stock group 60.

In fiber optics applications, dependence on commercial standards documents has been accepted DoD practice. This dependence on commercial standards has proved to be a stumbling block in the military application of fiber optics for several reasons. Commercial standards documents are primarily oriented to the commercial sector and telecommunications, and consequently haven't fully addressed short distance, severe environment military platform applications or tactical short- and long-haul environments. These documents employ a different hierarchical structure and don't provide the interleaving, cross referencing document structure that the military relies on. Successful applications of fiber optics in the military are notably those in which program resources were sufficient to develop adequate specifications and standards within the program.

Direct funding of specification and standards developments is recommended as an integral and important part of a QPL fiber optics program. This development activity will serve the military independent of commercial specification and standards development.

The establishment of a military fiber optics OPL and the standardization it provides will encourage component manufacturers to reassess this market and provide qualified components as applications proliferate.

4. A Comprehensive Testing Program for Fiber Optics Components Must be Established.

In order to establish qualified fiber optics components, a comprehensive testing program must be established within the DoD. At present fiber optics component testing is performed by individual DoD elements depending on specific laboratory interests and availability of funding. Although eventually component testing and qualification can be conducted by both commercial and industrial laboratories. However, because of the current developmental status of fiber optics test procedures, a coordinated, centrally-administered program is essential.

Specifically, this program will accomplish the following:

- Provide characterization testing to verify performance and "in effect qualify the device Specifications" (e.g., are the right parameters being tested, is the specification adequate etc.).
- Select core sets of components for testing which satisfy a broad range of platform/airborne/land-based/undersea applications and military environments.
- Establish worst-case empirical test environments to accelerate aging effects and eliminate concerns of long term survival.

This particular testing program is necessary because of the primitive state of fiber optics components testing for severe environments. Many of the test method standards are derived from existing standards for conventional wire cables and other electro-optical devices intended for benign environments.

5. An Integrated Logistics Support Program Should Be In Place When The Technology Is Qualified For Service Use.

Integrated Logistic Support (ILS) capabilities for fiber optics must be developed concurrently with the introduction of this technology into major weapons systems. The requirements for built-in automatic test (BIT) must be determined during initial system design. The requirements for a support structure, including maintenance procedures, test and repair equipment, documentation, training and supply must be developed early in the acquisition process to ensure timely and coordinated development of the capability of new weapon systems technology. Pilot support systems fielded during demonstration programs provide an opportunity to establish that fiber optic systems can be supported in the field as they provide data for determining the full scale system support requirements.



## 6. Reporting Procedures For Wire and Cable Maintenance Must be Improved.

The maintenance of wire and cables in all military environments is a major problem affecting operational readiness. Current maintenance procedures that do not provide for reporting wiring failures should be modified to assign work unit codes for both cables and connectors. This reporting system will ensure that wire and connection failures are identified, described and reported. For those military systems experiencing readiness problems associated with electronic systems, complete wiring investigations should be conducted to establish the incidence in wire and connector related failure. Fiber optic connection systems which simplify the interconnect should be developed as replacements for conventional wiring. Built-in-test (BIT), VHSIC and fiber optic connection systems should be developed in coordination to achieve the potential for synergistic enhancement of readiness provided by these new technologies.

## 7. Policy Changes Must Be Implemented To Ensure Full Consideration Of Fiber Optics.

Certain policy actions by DoD are essential to the full development of fiber optics. The following are suggested targets for DoD policy action:

- Establish system level requirements which realistically assess EMI/EMP threat levels and reflect the full capability of fiber optics to address those threat levels.
- Address the program manager interface. Establish incentives for full consideration of fiber optics at this level.
- Consider education as an essential aspect of understanding and full application of new technologies. Provide application information in the form of case studies, and past experience in the form of DoD wide handbook(s) for application.
- Prepare acquisition documentation and general specifications as models/guides for development/acquisition. Ensure a sharing of information throughout the DoD.

IF THE ABOVE RECOMMENDATIONS ARE IMPLEMENTED, THE FULL POTENTIAL OF FIBER OPTICS CAN BE REALIZED BY DOD AND THE PROGRAMMATICS CAN SERVE AS A MODEL FOR CONTRIBUTING TO THE GROWTH OF HIGH TECHNOLOGY INDUSTRIES.