

AD-A136 681

SHUTTLE FLIGHT TEST OF AN ADVANCED GAMMA-RAY DETECTION  
SYSTEM(U) FLORIDA UNIV GAINESVILLE SPACE ASTRONOMY LAB  
A C RESTER NOV 83 AFOSR-TR-83-1201 AFOSR-83-0116

1/1

UNCLASSIFIED

F/G 20/8

NL



END  
DATE  
FILMED  
2 84  
DTIC

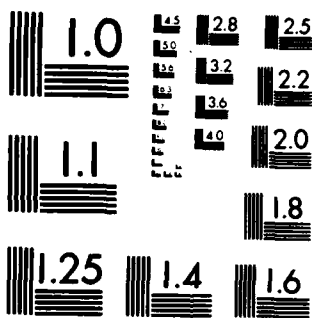

MICROCOPY RESOLUTION TEST CHART  
NATIONAL BUREAU OF STANDARDS-1963-A

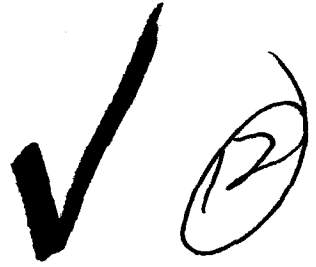

AD-A136681

FINAL SCIENTIFIC REPORT

SHUTTLE FLIGHT TEST OF AN ADVANCED  
GAMMA-RAY DETECTION SYSTEM

U.S. Air Force Office of Scientific Research  
Grant AFOSR-83-0116  
to the University of Florida

1 October 1982 - 31 March 1983

by

Alfred C. Rester, Jr.  
Principal Investigator

Space Astronomy Laboratory  
University of Florida  
1810 N.W. 6 Street  
Gainesville, FL 32601

November 1983

DTIC FILE COPY

DTIC  
ELECTED  
DEC 23 1983  
S  
A

88 12 22 021

Approved for public release;  
distribution unlimited.

**UNCLASSIFIED**

SECURITY CLASSIFICATION OF THIS PAGE (When Data Entered)

REPORT DOCUMENTATION PAGE		READ INSTRUCTIONS BEFORE COMPLETING FORM
1. REPORT NUMBER <b>AFOSR-TR- 83 - 1201</b>	2. GOVT ACCESSION NO. <b>AD-A136 681</b>	3. RECIPIENT'S CATALOG NUMBER
4. TITLE (and Subtitle) <b>SHUTTLE FLIGHT TEST OF AN ADVANCED GAMMA-RAY DETECTION SYSTEM</b>		5. TYPE OF REPORT & PERIOD COVERED <b>Final Scientific Report 10/01/82 - 03/31/83</b>
7. AUTHOR(s) <b>Dr. Alfred C. Rester, Jr.</b>		6. PERFORMING ORG. REPORT NUMBER <b>AFOSR-83-0116</b>
9. PERFORMING ORGANIZATION NAME AND ADDRESS <b>University of Florida Space Astronomy Laboratory 1810 NW 6 Street, Gainesville, FL 32601</b>		8. CONTRACT OR GRANT NUMBER(s) <b>AFOSR-83-0116</b>
11. CONTROLLING OFFICE NAME AND ADDRESS <b>AFOSR/INP Building 410 Bolling Air Force Base, D.C. 20332</b>		10. PROGRAM ELEMENT, PROJECT, TASK AREA & WORK UNIT NUMBERS <b>61102F 2309/A1</b>
14. MONITORING AGENCY NAME & ADDRESS (if different from Controlling Office)		12. REPORT DATE <b>11/83</b>
		13. NUMBER OF PAGES <b>19</b>
		15. SECURITY CLASS. (of this report) <b>UNCLASSIFIED</b>
		15a. DECLASSIFICATION/DOWNGRADING SCHEDULE
16. DISTRIBUTION STATEMENT (of this Report)  <b>Approved for public release; distribution unlimited.</b>		
17. DISTRIBUTION STATEMENT (of the abstract entered in Block 20, if different from Report)		
<div style="text-align: center;">  </div>		
18. SUPPLEMENTARY NOTES		
19. KEY WORDS (Continue on reverse side if necessary and identify by block number) <b>Space Shuttle Mission Gamma-ray detector Bismuth germanate detector Germanium detector</b>		
20. ABSTRACT (Continue on reverse side if necessary and identify by block number) <b>The Space Astronomy Laboratory plans to fly an advanced gamma-ray spectro- meter aboard a future Shuttle flight. The "GRAD" spectrometer employs a new bismuth germanate (BGO) anticompton shield and n-type high purity germanium detector. BGO, because of its high atomic number, requires only 1/12 the volume and 1/6 the weight of an equally sensitive sodium iodide crystal. The n-type germanium detector is at least 25 times more resistant to neutron radiation damage than a conventional detector and has a very broad spectral response of 5 keV to 10 MeV. Neither of these materials has been subjected to the space (continued)</b>		

DD FORM 1 JAN 73 1473

EDITION OF 1 NOV 68 IS OBSOLETE  
S/N 0102-LF-014-6601

**UNCLASSIFIED**

SECURITY CLASSIFICATION OF THIS PAGE (When Data Entered)

UNCLASSIFIED

Block 20. Abstract (continued)

cont

environment as working components of a detector system. The radioactivation of the new detector materials by cosmic rays and fast neutrons, as well as other effects of launching, landing and operation in the space environment on the detector system will be monitored and calibrated. Early information on gamma-ray background from activation of the shuttle itself will also be obtained. In addition to the technological information derived from the experiment, high energy-resolution spectra of the sun and the galactic center will be taken.



UNCLASSIFIED

## I. INTRODUCTION

Shortly after the OSS-1 pallet of scientific experiments was flown into space on the STS-3 mission in March, it came to our attention that the chamber inside the Thermal Cannister Experiment (TCE) might become available for a new experiment on a possible reflight of OSS-1 on the STS-5 mission in November of 1982. DARPA approval for a proposed Gamma-Ray Advanced Detector Experiment was forthcoming in mid-April, and the manufacturers started cutting metal early in May to insure delivery of a functioning instrument to the Goddard Spaceflight Center by June 21 for integration onto the OSS-1 pallet. On May 17, however, a decision not to reflly OSS-1 was made at NASA headquarters; we are therefore working toward an experiment with GRAD on STS-11, the next suitable mission, scheduled for January 31, 1983.

The original plan to fly on STS-5 forced certain constraints on the design of the GRAD spectrometer. In the first place, it was necessary that the instrument mechanically resemble the dummy experiment (a cylinder of water with heat sensors) it was to replace inside the TCE. Furthermore, it had to make use of existing power connections and resemble the TCE to the OSS-1 avionics unit. Finally, the severe time constraint required the use of an axially-symmetric, open-ended geometry, rather than a more efficient asymmetric design for the bismuth germanate (BGO) anticompton shield, as the technology of working with BGO was not sufficiently well developed for the manufacturer to guarantee delivery of a shield of the latter type within the time allotted. In spite of these

limitations, the GRAD shield is the most advanced BGO shield to have been fabricated to date.

Certain technological questions of great importance to developers of advanced, space-based monitoring systems require that high priority be given to an early flight of GRAD. Early use has been made of BGO in space<sup>1)</sup>; however the nature of that application is such that no data on the performance of BGO as a gamma-ray detector can be obtained. The advantages of BGO over conventional scintillators in terms of durability, weight and volume savings, and greater immunity to radiation damage make it potentially of great use in space applications. This is especially so in the light of recent advances in the technology of BGO crystal growth which have resulted in larger and less expensive crystals with improved energy resolution and enhanced light output, and in the technology of light detection with new devices such as photodiodes and microchannel plates (see ref. 2 for up-to-date reports). That n-type germanium has an order of magnitude better energy resolution than does sodium iodide and may be at least 25 times less susceptible to radiation damage than conventional p-type germanium makes it potentially of great usefulness as well. Hence the questions of how well these new materials will withstand the rigors of launching and operation in space, how well they operate in the space environment as detectors, and how susceptible they are to radioactivation and to degradation from radiation damage must be addressed in a timely fashion, as considerable technological advantage may be made of them if the answers are as favorable as expected.

## II. STATUS OF GRAD

### 2.1 The Detectors.

As of March 1983, both the BGO anticompton shield and the n-type high-purity germanium detector complete with its space-qualified cryostat and dewar have been fabricated. The basic design of the detector configuration is shown schematically in Figures 1 and 2: an axially symmetric configuration of six 5.75"-long by 1.50"-thick trapezoidal segments of BGO, each with its own space-qualified Hamamatsu photomultiplier, surrounds a 55-mm diameter by 57-mm long germanium detector (32% the efficiency of a standard 3" x 3" NaI detector and 2 keV FWHM resolution at 1332 keV). Figures 3-5 are photographs of the actual detectors themselves. The dewar is a slight modification of a design which has been successfully flown on sounding rockets. In the present case, a matrix of activated charcoal is used to hold the liquid nitrogen together in zero gravity so as to prevent the discharge of any liquid through the vents. With a charge of 30 liters of liquid nitrogen, the holding time of the dewar plus cryostat has been measured to be 18 days in the laboratory. Preliminary reports on the instrument have been presented at international conferences (refs. 3, 4, 5).

### 2.2 The Electronics.

The nuclear electronics for the original OSS-1 flight configuration of GRAD were based on commercially available NIM (Nuclear Instrument Module) circuit boards. The change in flight plans, however, made it necessary for us to drastically cut the





Figure 3. The hexagonal annulus of BGO crystals prior to assembly at the factory.

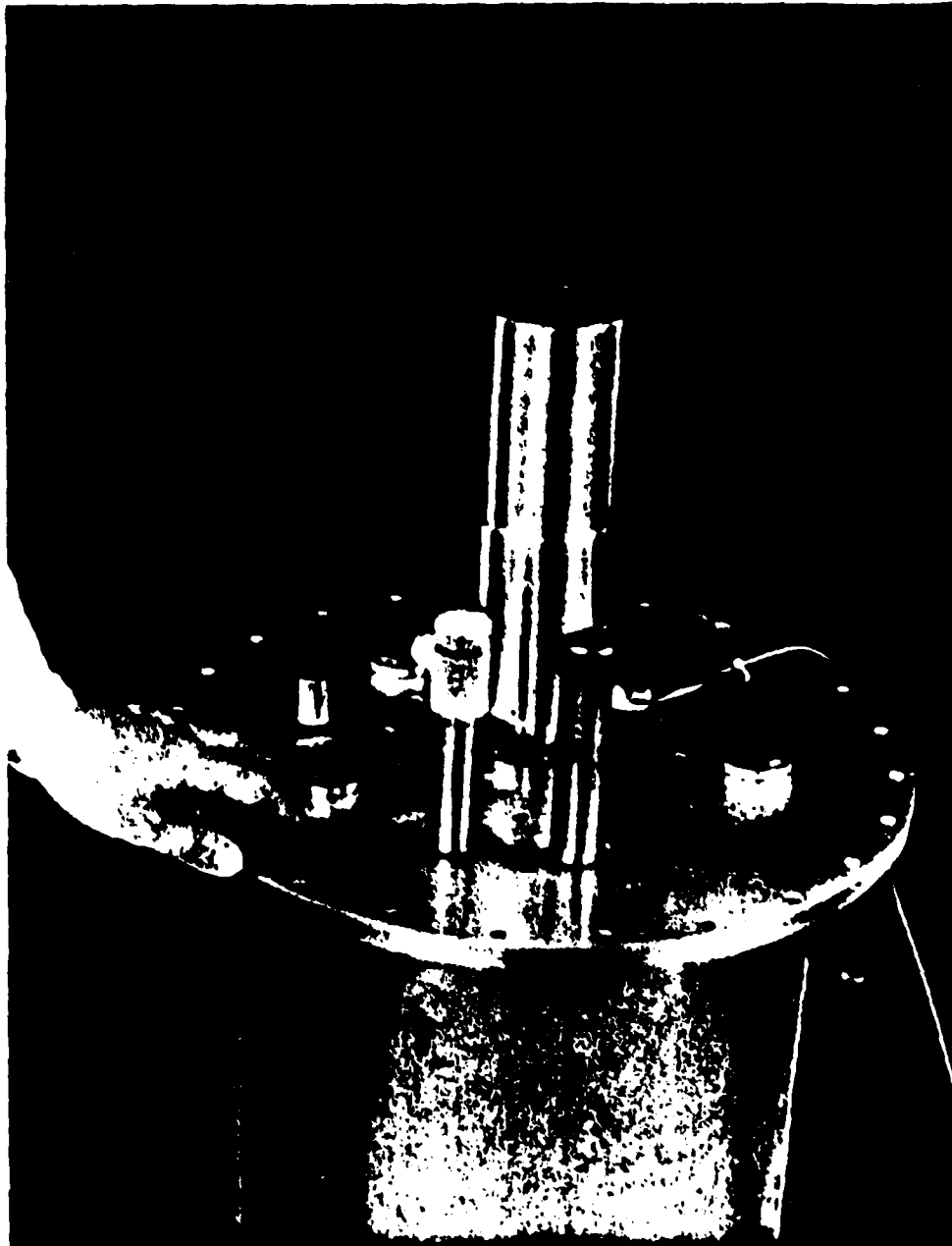

Figure 4. The nGe detector in its cryostat.

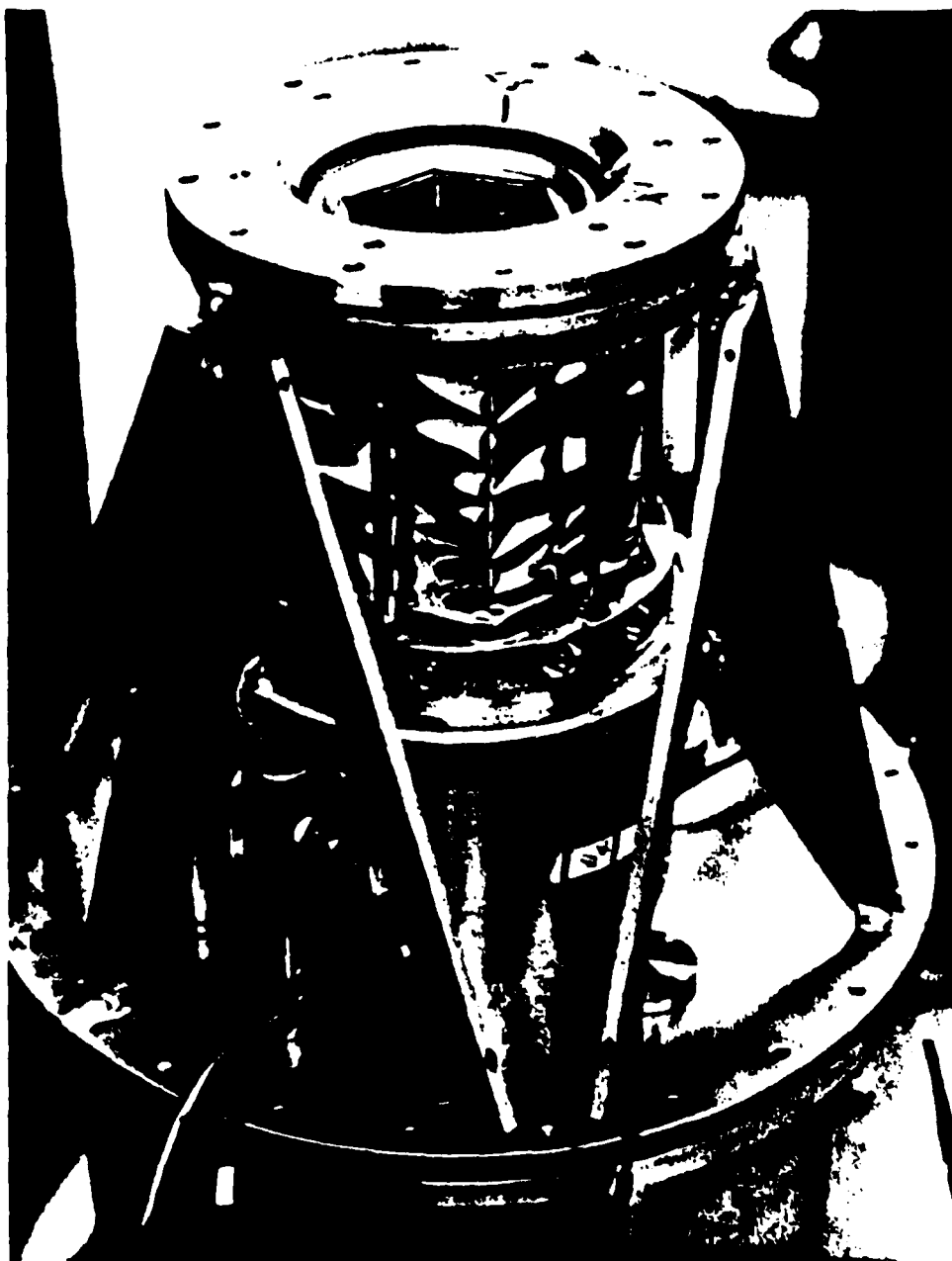

Figure 5. The completed BGO shield mounted on the nGe detector.

electrical power budget by completely redesigning the electronics. By making use of customized circuitry plus circuit boards from a newly developed portable multichannel analyzer (the Canberra Series 10), we expect to be able to lower the power consumption from 90 watts to about 20 watts.

Figure 6 is a block diagram of the revised electronics. The energy signal from the high-purity nGe detector is first preamplified and then routed to three linear amplifiers which supply 60- $\mu$ s shaped signals to three separate 4096-channel analog-to-digital converters (ADC's) through three independent single-channel analyzers (SCA's). These circuits are adjusted such that the first ADC covers the range 30-500keV in 4096 channels; the second covers the range 30keV to 2MeV; and the third, the entire range from 30KeV to 10MeV. This redundancy will reduce the probability of failure and provide adequate keV/channel resolution across the entire spectrum.

The timing between the nGe detector and the BGO shield is determined with fast timing signals from the shield photomultipliers and the nGe preamplifier timing output routed into constant fraction discriminators (CFD's). The nGe CFD has lower and upper level discriminators set to cover the range 30-keV-10MeV. The BGO CFD has two sets of lower and upper level discriminators: one to span the range 30keV-10MeV and the other to define a window around the 511 keV line in the BGO spectrum. Pulses passed through the 511keV window are used to overrule the veto in the third (full spectrum) ADC line, so as to prevent the vetoing of pair escape peaks from high-energy gamma-rays. The fast timing signals from

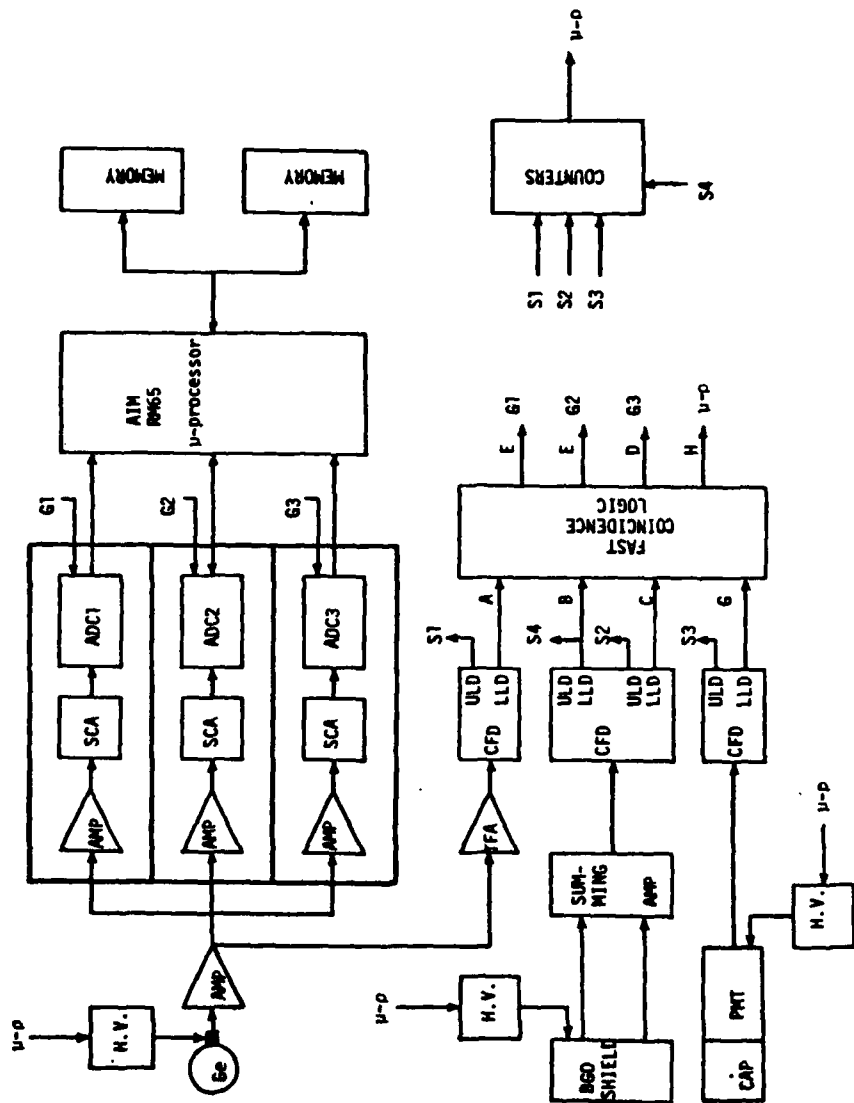

Figure 6. Block diagram of GRAD electronics configuration.

TABLE 1.

GRAD FLIGHT OPPORTUNITIES

<u>CARRIER</u>	<u>EARLIEST MISSION</u>	<u>DATE</u>
APC	STS-11	JAN 29, 1984
DIRECTLY MOUNTED	STS-11	JAN 29, 1984
SPOC	STS-12	MARCH 18, 1984
HITCHHIKER (COPE)	STS-14	MAY 8, 1984
OAST-1	STS-14	MAY 8, 1984

the two CFD's are routed into a fast coincidence circuit, which then emits stretched pulses to control the gates on the ADC's.

When a nuclear disintegration occurs in the calibration probe, the fast coincidence logic sends an interrupt to the microprocessor to flag the arrival of a calibration signal from the second ADC, which is then stored in the calibration spectrum.

### 2.3 Opportunities for Flight in FY1984.

The GRAD experiment is now an "approved" mission with the Space Division. Recognizing the importance of an early flight of the experiment the SD/YCM and SD/YO offices are studying the mission opportunities listed in Table 1. Earliest flight and lowest cost are likely to be on the STS-11 mission, either directly mounted to the Getaway Special (GAS) beam or integrated onto an Adaptive Payload Carrier (APC). In either case, both power and telemetry would be provided. Costs for each option are being prepared by SD and will be communicated directly to DARPA.

We have based the budgets of the present proposal on an STS-11 flight in January of 1984.

### 2.4 Calibration of the Spectrometer.

Two types of calibration are involved here: laboratory and on board. Prior to the flight, the energy response function for gamma rays in the energy range 20 keV to 10 MeV, the absolute efficiency, the angular response and the Compton suppression will be determined. The expected energy response of the germanium detector to a typical monochromatic gamma-ray source is shown in Figure 7,

## ENERGY RESPONSE FUNCTION OF THE nGe DETECTOR

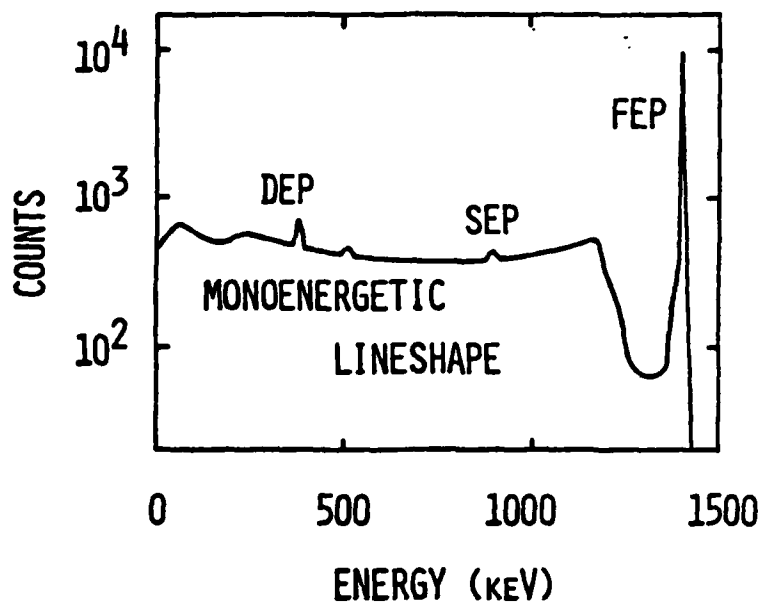

### EXPECTED PERFORMANCE

- ENERGY/CHANNEL NONLINEARITY LESS THAN 1 KEV FOR  
1 - 5 MeV, LESS THAN 10 KEV FOR 5 - 10 MeV
- ENERGY RESOLUTION  $\approx 2$  KEV AT 1 MeV
- COMPTON FRACTION  $\approx 3$  AT 1 MeV
- PEAK TO COMPTON RATIO  $\approx 50$  TO 1 AT 1 MeV

Fig. 7



and a rough estimate of the angular response is sketched in Figure 8. The Compton suppression of the system as measured at the Space Astronomy Laboratory is shown in Figure 9. Without Compton suppression, the peak-to-Compton ratio of the nGe detector is 50, with the suppression it averages about 250.

On-board calibrations will be performed with a probe consisting of a weak radioactive source embedded in a small plastic scintillator which in turn will be mounted on a photomultiplier tube. When a gamma-ray is emitted the accompanying beta-ray will produce a scintillation pulse which will route the ensuing signal, if there is one, from the gamma-ray detector into an area of the micro-processor memory reserved for calibration data. The source will be sufficiently weak that accumulation of a calibration spectrum will take about two hours.

#### 2.5 Low Background Counting.

All materials become radioactive to some extent when exposed to the radiation belts in space; hence a gamma-ray background which has the effect of lowering the signal-to-noise ratio of the instrument. A second effect of exposure to the charged particles and neutrons in the belts is actual damage to the detector materials with concomitant degradation in performance. To aid our study of the susceptibility of BGO and n-type germanium to these effects we will perform low background counting experiments on the spectrometer components themselves as well as sample crystals to be flown along with the spectrometer for possible destructive analysis if required. The components and samples will be studied in the

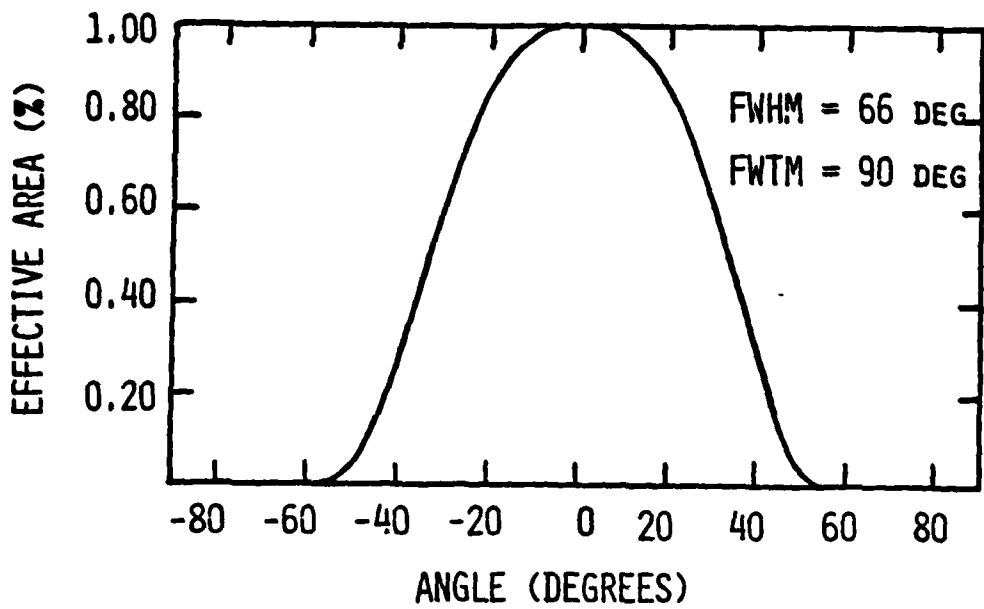

COLLIMATING EFFECT OF THE BGO

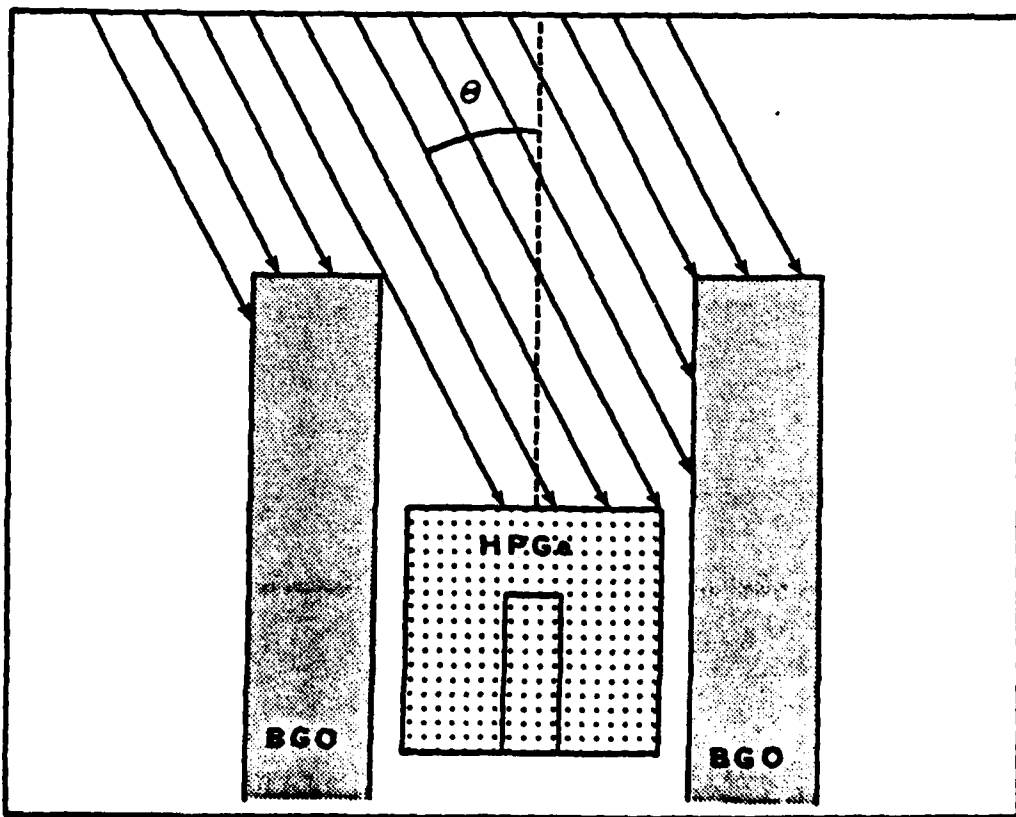

Fig. 8. Angular Response of the GRAD Spectrometer

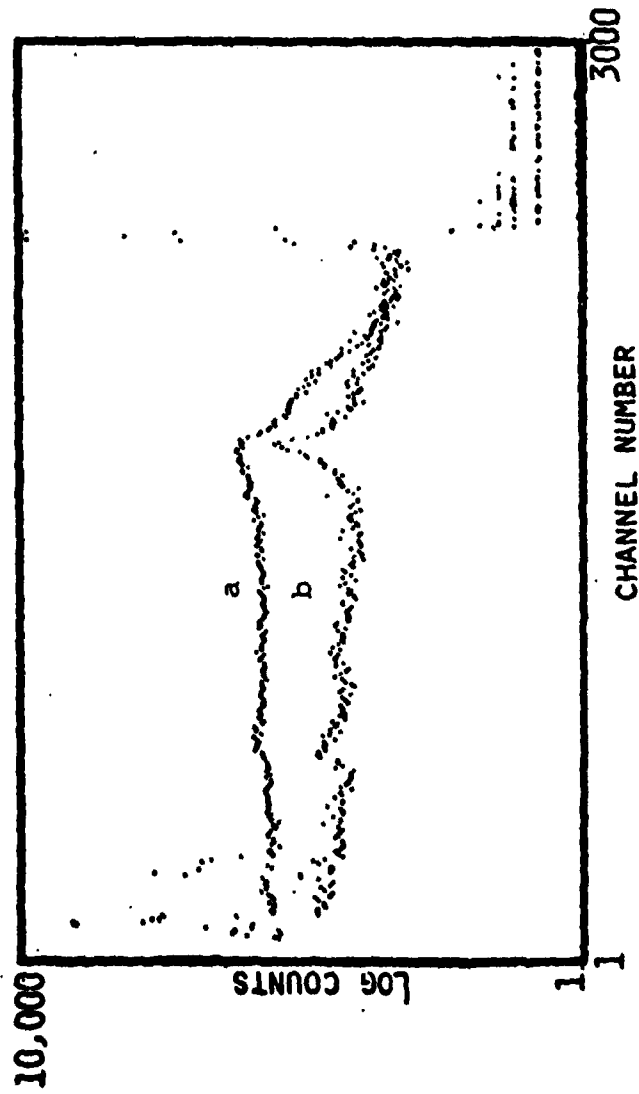

Figure 9. Compton suppression of the GRAD spectrometer. The unsuppressed spectrum (a) has a peak-to-Compton ratio of 50: the Compton-suppressed spectrum (b) has a ratio of about 250.

low-background counting facility of the Oak Ridge National Laboratory, flown on the mission along with a dosimetry package and, shortly after touchdown, recounted in a portable counting facility at the landing base (Edwards AFB or Kennedy Space Flight Center). For a study of the long-lived activity, the system will be returned to Oak Ridge. Along with the on-board spectra these carefully made measurements will help us to determine whether, as we expect, the BGO and n-type germanium are less susceptible than other materials.

#### 2.6 Data Analysis Software.

Software for the analysis of gamma-ray spectra has been developed in our laboratory independent of Federal sponsorship; this will be adapted for use on the GRAD project to provide us with the capability of near realtime analysis during mission operations at the Johnson Space Flight Center as well as detailed analysis to be done postmission at SAL.

The software for the on-board microprocessor is being handled by a contractor (Berle Berson) and in house at SAL.

#### 2.7 Cryogenics.

The detector cryostat and dewar have been constructed and overpressure tests have been conducted. Vibration tests will be performed in September. A portable dewar for filling the detector dewar in the OPF and finally on the launching pad is under development. A procedure for the launching pad operation has to be worked out in detail. Only tentative plans can be made until the mission parameters are better defined. Costing for this operation

has not been included in the budget. Topping off the dewar on the launching pad should be a very simple matter and hence inexpensive as long as the cargo bay doors do not have to be opened for that job alone. The fact that the dewar has an 18-day static holding time should provide sufficient leeway for us to find a convenient time for the topping off operation.

## 2.8 Astronomical Objectives.

During the STS-11 mission the sun and the galactic center will be separated by about 40 degrees. As the counting efficiency and angular resolution of the present spectrometer are somewhat limited, observations of these objects will serve more to determine spectrometer sensitivity than advance our knowledge of astronomy. The instrument will have the highest energy resolution and broadest bandwidth in the line-spectrum region of any gamma-ray spectrometer flown to date, so the opportunity will exist for the observation of unusual occurrences.

The background of gamma-rays from the interaction of the radiation belt with the orbiter itself may limit the sensitivity of GRAD. This problem is of critical importance itself, as it has not yet been studied. Our experiment should provide early data on its magnitude and energy distribution.

## 2.9 References

1. D.N. Baker, P.R. Higbie, R.D. Belian, E.W. Hones, Jr., and R. Klebesadel; The I.M.S. Sourcebook (1982) 82.
2. International Workshop on Bismuth Germanate, Princeton University, Nov. 10-13, 1982. Proceedings to be published in Nucl. Instr. Methods.
3. A.C. Rester, F.E. Dunnam, F. Giovane, P.S. Haskins, R.B. Piercey, and J.L. Weinberg; Contributed paper to Conference on High Angular Momentum Properties of Nuclei, Oak Ridge, TN. Nov. 2-4, 1982, in press.
4. A.C. Rester, R.B. Piercey, F. Giovane, P.S. Haskins, H.A. Moffitt II, J.L. Weinberg, F.E. Dunnam and J.D. Hendricks; invited paper to International Workshop on Bismuth Germanate, Princeton University, Nov. 10-13, 1982, proceedings to be published in Nucl. Instr. Methods.
5. A.C. Rester, R.B. Piercey, F. Giovane, P.S. Haskins, H.A. Moffitt II, J.L. Weinberg, F.E. Dunnam and J.D. Hendricks; contributed paper to Workshop on  $e^+e^-$  Pairs in Astrophysics, Goddard Space Flight Center, Jan. 6-8, 1983.