

AD-A136 350

FURTHER DEVELOPMENT OF A DUAL-PROBE DIGITAL SAMPLING
(DPDS) TECHNIQUE FOR... (U) BDM CORP MONTEREY CA
F NEUHOFF SEP 82 NPS-67-82-01CR N00014-79-C-0088

1/3

UNCLASSIFIED

F/G 14/2

NL

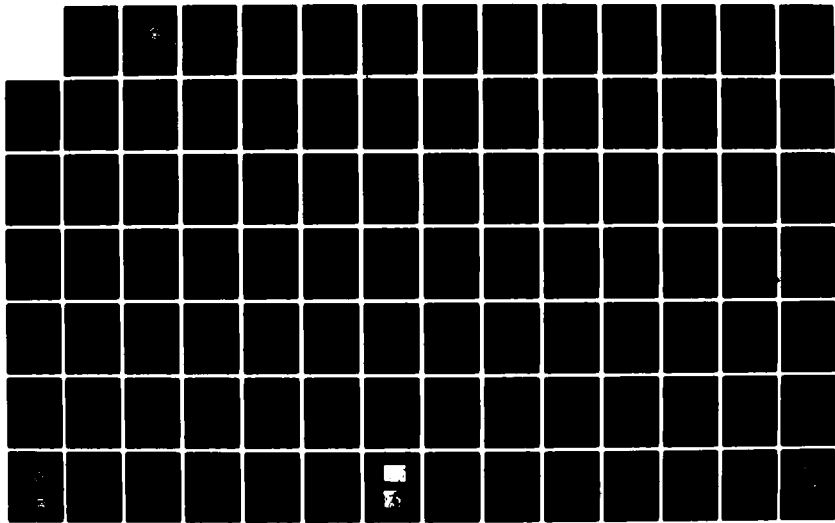

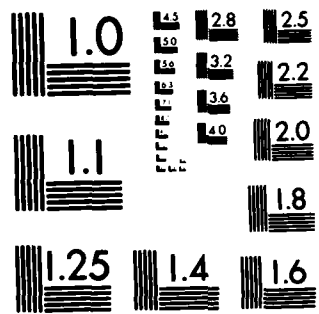

MICROCOPY RESOLUTION TEST CHART
NATIONAL BUREAU OF STANDARDS-1963-A

(2)

NPS67-82-01CR

NAVAL POSTGRADUATE SCHOOL

Monterey, California

A136350



DTIC
DEC 27 1983
A

CONTRACTOR REPORT

FURTHER DEVELOPMENT OF A DUAL-PROBE DIGITAL SAMPLING (DPDS) TECHNIQUE FOR MEASURING FLOW FIELDS IN ROTATING MACHINES

F. Neuhoff
BDM Corporation
P.O. Box 2019
Monterey, CA 93940

September 1982

Contractor Report

Approved for public release; distribution unlimited.

Prepared for:
Naval Postgraduate School
Monterey, California 93943

DTIC FILE COPY

83 12 27 60

NAVAL POSTGRADUATE SCHOOL

Monterey, California

Rear Admiral J. J. Ekelund
Superintendent

D. A. Schrady
Provost

The work reported herein was carried out for the Naval Postgraduate School by BDM Corporation under Contract Number N00014-79-C-0088. The work was part of a program to develop improved methods for transonic turboaerodynamics and was funded in part by the Office of Naval Research, Project SQUID.

This report was prepared by:

F. NEUHOFF
EXOTECH, Inc.
Pruneyard Towers 1, Suite 337
1901 S. Bascom Avenue
Campbell, CA 95008

Publication of the report does not constitute approval of the sponsor for the findings or conclusions. It is published for information and for the exchange and stimulation of ideas.

Reviewed by:

Approved by:

R. P. SHREEVE, Director
Turbopropulsion Laboratory

D. M. LAYTON, Acting Chairman
Department of Aeronautics

Released by:

WILLIAM M. TOLLES
Dean of Research

UNCLASSIFIED

SECURITY CLASSIFICATION OF THIS PAGE (When Data Entered)

REPORT DOCUMENTATION PAGE		READ INSTRUCTIONS BEFORE COMPLETING FORM	
1. REPORT NUMBER NPS67-82-01CR	2. GOVT ACCESSION NO. AD-A136350	3. RECIPIENT'S CATALOG NUMBER	
4. TITLE (and Subtitle) Further Development of a Dual-Probe Digital Sampling (DPDS) Technique for Measuring Flow Fields in Rotating Machines		5. TYPE OF REPORT & PERIOD COVERED Contractor Report January 1982-December 1982	
		6. PERFORMING ORG. REPORT NUMBER	
7. AUTHOR(s) F. NEUHOFF		8. CONTRACT OR GRANT NUMBER(s) N00014-79-C-0088	
9. PERFORMING ORGANIZATION NAME AND ADDRESS BDM Corporation P. O. Box 2019 Monterey, CA 93943		10. PROGRAM ELEMENT, PROJECT, TASK AREA & WORK UNIT NUMBERS	
11. CONTROLLING OFFICE NAME AND ADDRESS Naval Postgraduate School Monterey, CA 93943		12. REPORT DATE September 1982	
		13. NUMBER OF PAGES 209	
14. MONITORING AGENCY NAME & ADDRESS (if different from Controlling Office)		15. SECURITY CLASS. (of this report) UNCLASSIFIED	
		15a. DECLASSIFICATION/DOWNGRADING SCHEDULE	
16. DISTRIBUTION STATEMENT (of this Report) Approved for public release, distribution unlimited.			
17. DISTRIBUTION STATEMENT (of the abstract entered in Block 20, if different from Report)			
18. SUPPLEMENTARY NOTES Final Report. Principal Investigator, Dr. R. P. Shreeve, Turbopropulsion Laboratory, Code 67Sf, Naval Postgraduate School, Monterey, CA 93943.			
19. KEY WORDS (Continue on reverse side if necessary and identify by block number) Compressor Measurements High Response Probes Turbomachinery Flow Fields			
20. ABSTRACT (Continue on reverse side if necessary and identify by block number) Following a review of the technique, detailed descriptions are given of the procedures developed for calibrating and applying a system of two simple semi-conductor (Kulite) pressure probes to measure the velocity field from a high speed rotor. Calibration tests of a "second generation" probe set in a steady free jet, procedures for deriving calibration equations and subsequent verification tests are described in turn. Data reduction procedures and software involved in the application of the probe system with controlled			

DD FORM 1473

JAN 73

EDITION OF 1 NOV 68 IS OBSOLETE
S/N 0102-LF-014-6601

UNCLASSIFIED

SECURITY CLASSIFICATION OF THIS PAGE (When Data Entered)

UNCLASSIFIED

SECURITY CLASSIFICATION OF THIS PAGE (When Data Entered)

→ digital data sampling, to obtain the blade-to-blade velocity field in a machine are documented with examples of results. Successes and potential problems are evaluated.

*

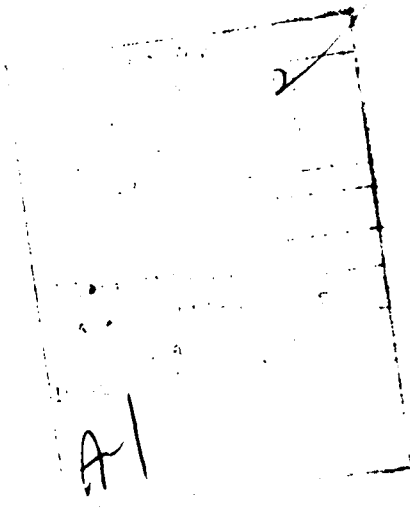

S/N 0102-LF-014-6601

UNCLASSIFIED

SECURITY CLASSIFICATION OF THIS PAGE(When Data Entered)

TABLE OF CONTENTS

	Page
LIST OF TABLES.....	
LIST OF ILLUSTRATIONS.....	
1. INTRODUCTION.....	1
2. MEASUREMENT CONCEPT.....	2
3. SECOND GENERATION PROBES.....	6
3.1. Probe Design.....	6
3.2. Temperature Sensitivity.....	7
4. PROBE CALIBRATION.....	9
4.1. Calibration Procedure.....	9
4.2. Data Acquisition and Storage.....	11
4.3. Type "A" Probe Results.....	12
4.4. Type "B" Probe Results.....	13
4.5. Calibration Data Analysis.....	13
5. VERIFICATION TESTS.....	19
5.1. Verification Using Calibration Data.....	19
5.2. Verification on the Freejet.....	23
6. APPLICATION IN COMPRESSOR TESTS.....	26
6.1. Necessity of an Online-Calibration.....	26
6.2. Online Calibration.....	27
6.2.1. Procedure for Slope.....	28
6.2.2. Procedure for Type "A" Probe Intercept.....	28
6.2.3. Procedure for Type "B" Probe Intercept.....	32
6.3. Data Acquisition in TX-compressor Measurements.....	33
6.4. Data Reduction.....	37

	<u>Page</u>
6.5. Data Presentation and Evaluation.....	42
7. DISCUSSION AND CONCLUSIONS.....	44
APPENDIX A. CHANGES MADE TO SOFTWARE FROM (REF. 4).....	98
APPENDIX B. OUTPUT CHARACTERISTICS OF TYPE "A" AND TYPE "B" PROBES.....	105
APPENDIX C. DATA ACQUISITION PROGRAMS &KALIB AND &YAW.....	108
APPENDIX D. DATA REDUCTION PROGRAMS &REST8 AND &REST9.....	123
APPENDIX E. DATA EVALUATION PROGRAM &EVALU.....	129
APPENDIX F. CALIBRATION TEST PROGRAM &TEST.....	140
APPENDIX G. CALIBRATION DATA (C_{POB}) APPROXIMATION PROGRAM &RES10.....	149
APPENDIX H. TEST DATA ACQUISITION PROGRAM &ABKUL.....	154
APPENDIX I. PROCESSING PROGRAMS &SPLIT AND &WAVE FOR TEST DATA.....	166
APPENDIX J. DATA REDUCTION PROGRAM &ABRED.....	176
APPENDIX K. PLOTT PROGRAMS FOR REDUCED DATA.....	199
REFERENCES.....	205
DISTRIBUTION LIST.....	206

LIST OF TABLES

	<u>Page</u>
I. Data Acquisition System Hook Up	50
II. Raw Calibration Data from A-probe, One Mach Number, One Pitch Angle.....	51
III. Raw Data File Name Arrangements (A-probe).....	52
IV. Raw Data File Name Arrangements (B-probe).....	53
V. All Reduced Data from File ABNEW2.....	54
Via. Coefficients and Errors for Mach Number (X_{vel}) Approximation.....	55
Vib. Coefficients and Errors for Pitch Angle (ϕ) Approximation.....	55
VII. Errors in Mach Number, Pitch- and Yaw Angle for the Application of Calibration Procedure to Calibration Raw Data.....	56
VIII. Errors in Mach Number, Pitch- and Yaw Angle for A- and B- Probes Application Test in Freejet.....	57
IX. C_{POB} for all Calibration Configurations of Mach Number and Pitch Angle.....	58
Xa. Online Calibration Data for Actual Compressor Test (Run #119).....	59
Xb. Raw Steady State Data from A- and B-Probe Measurement (Run #119).....	60
XI. Arrangement of Data Within Raw Data File.....	61
XII. Explicit Output of Reduced Data (Run #119).....	62
XIII. Reduced Data for the First Blade Passage of Run #119.....	63
XIV. Errors in Mach Number, Pitch- and Yaw Angle for Varying Velocity Vectors.....	64
A-I Results Using Uncorrected Subroutine RPACE(&A2D, (Ref. 4).....	101

	<u>Page</u>
A-II Results Using Corrected Subroutine RPACE(&A2D), (Ref. 4).....	102
G-I Coefficients and Errors for C_{POB} Approximation Depending on X_{vel} and ϕ	151

LIST OF ILLUSTRATIONS

	<u>Page</u>
1. Probe Arrangement in Transonic Compressor.....	65
2. Controlled (Paced) Sampling Technique.....	66
3a. A-Probe Pressure (Gauge) vs. Yaw Angle.....	67
3b. B-Probe Pressure (Gauge) vs. Yaw Angle.....	68
4. High Response Transducer Probes.....	69
5. Temperature Sensitivity of a Kulite-Transducer....	70
6a. Calibration Facility Geometry (not to scale).....	71
6b. Free-Jet Calibration Apparatus.....	72
6c. Data Acquisition System.....	73
7. Pressure Readings vs. Yaw Angle.....	74
8. Kulite Transducer Output Depending on Time.....	75
9. Type A-Probe Calibration Data at Mach = 0.4.....	76
10. Type B-Probe Calibration Data at Mach = 0.4.....	77
11a. Probe Tip with Dirt in Some Holes	78
11b. Probe Tip with Dirt in Some Holes.....	78
12. Type B-Probe Calibration Data at Mach = 0.4.....	79
13. Type A-Probe Output Demonstrating Characteristic Values.....	80
14. Type B-Probe Calibration Data.....	81
15a. Approximation of X (resp. Mach Number) as Function of Coefficients β and γ	82
15b. Approximation of Pitch Angle ϕ as Function of Coefficients β and γ	83
16. Errors as Specified Depending on Mach Number and Pitch Angle.....	84
17. Combination Pressure Temperature Probe (Tip Detail).....	85

	<u>Page</u>
18. Pressure Coefficient for Type A-Probe at Zero Yaw Angle as Function of Mach Number and Pitch Angle.....	86
19. Pressure Coefficient for Type B-Probe for Zero Yaw Angle as Function of Mach Number and Pitch Angle.....	87
20a. Paced Data from Type A-Probe.....	88
20b. Paced Data from Type A-Probe.....	89
20c. Paced Data from Type B-Probe.....	90
20d. Paced Data from Type B-Probe.....	91
21. Measurement Results at 50% Speed, Midspan, Peek Efficiency.....	92
22. Relative Velocity Distribution W_2 at Rotor Trailing Edge (schematic).....	93
23. Velocity Triangles for Varying Values of the Relative Velocity X_w	94
24. Dependence of Absolute (X_v) and Relative (X_w) Velocities on Yaw Angle.....	95
25. Influence of Incorrect Pneumatic Probe Pressure Readings Run 119.....	96
26. Pressure Coefficient Versus Yaw Angle for Type A-Probe at Specific Positions in Rotor Flow Field.....	97
A-1. Unchanged Listing of Subroutine RPACE from Program & A2D.....	103
A-2. Corrected Statement of Subroutine RPACE from Program & A2D.....	104
B-1. Indicated Pressure Versus Yaw Angle for a Pneumatic Probe Equivalent to a Type A-Probe.....	107
C-1. Flow Chart of Data Acquisition Program & Yaw.....	114
C-2. Listing of Calibration Data Acquisition Program & YAW.....	115
C-3. Flow Chart of Data Acquisition Program & KALIB....	118

	<u>Page</u>
C-4. Listing of Calibration Data Acquisition Program & KALIB.....	119
D-1. Flow Chart of Data Reduction Program & REST 8/9...	126
D-2. Listing of Reduced Data Approximation Program & REST9.....	127
E-1. Flow Chart of Data Evaluation Program & EVALU....	134
E-2. Listing of Calibration Data Evaluation Program & EVALU.....	135
F-1. Flow Chart of Calibration Evaluation Program & TEST.....	144
F-2. Listing of Program to Test the Quality of the Calibration: & TEST.....	145
G-1. Listing of Program to Approximation C_{POB} Values: & RES10.....	152
H-1. Flow Chart of Data Acquisition Program & ABKUL....	159
H-2. Listing of Data Acquisition Program & ABKUL.....	161
I-1. Listing of Program to Split Up Big Raw Data Array from A- and B- Probes into Two Smaller Arrays: & SPLIT.....	170
I-2. Flow Chart of Data Acquisition and Plotter Program & WAVE.....	172
I-3. Listing of Program to Plott Raw Data Waveforms: & WAVE.....	174
J-1. Flow Chart of Data Reduction Program & ABRED.....	183
J-2. Listing of Data Reduction Program & ABRED.....	190
K-1. Flow Chart of Plot Programs & PLOTX, & PLOTY or &PLOTP.....	203
K-2. Listing of Reduced Data Plot Program & PLOTX.....	204

1. INTRODUCTION

The development of the measurement technique reported here was required for the determination of the periodic flow field behind the rotor of a small, single-stage axial compressor. With the rotational speed of the rotor of 30,000 RPM at design conditions, the 18 blades of the rotor result in a blade-passage frequency of 9 KHz. Thus a high response measurement technique was essential. As reported earlier in Ref. 1, the means for determining the time-averaged flow at all speeds is available, and such measurements have been made to 50% speed.

The basic idea of the present technique was established some time ago (Refs. 2, 3, 4). This report gives a brief review of the measurement concept, results obtained with a first set of probes, and describes in detail the calibration and application of a new set of probes. The new probes have the advantage of being only two-thirds the size of the old ones.

2. MEASUREMENT CONCEPT

As described in detail in Ref. 2, a dual-probe digital sampling technique is used to determine the flow field behind the rotor in a real time regime. The technique incorporates two high response Kulite pressure transducers (Fig. 1). Using two trigger signals from the compressor shaft (one per revolution and one per blade), digitization of signal data can be controlled from the probes which are shown in Fig. 2. 128 locations can be selectively triggered for any one blade passage, thus giving good resolution for the specific area to be covered. The control device for the computer acquisition of the data is the PACER. Details of this device, which was developed in-house, can be found in Refs. 2 and 3.

Two major changes to the hard- and software of the PACER were made recently which are reported in Ref. 4. These changes made the lock-on to blade passing frequency totally automatic and reliable, and significantly reduced the total time for acquisition of a set of data. During the period reported here, several errors were found in the work presented in Ref. 4; Appendix A identifies the errors and their corrections.

The measurement system consists of two pressure probes, one the so-called type "A" probe which is essentially a total pressure probe, and the so-called type "B" probe, a total

pressure probe bent up 35° from the zero pitch, zero yaw axis, in the plane of zero yaw. The PACER allows data to be acquired from each of the two probes when they are at identically the same location with respect to the rotor. The probes can be rotated about the sensor tip. It is noted that their outputs when set at different yaw angles could as well be considered as the output of different probes of fixed geometry. Earlier studies have shown the dependency of a total pressure and a type "B" probe on yaw angle. Appendix B gives a brief discussion and outlines the use which can be made of the probe characteristics.

In knowing the output for a certain yaw angle of the "A" probe and its output for zero yaw angle, as well as the output of the "B" probe for zero yaw angle at the same relative location, three different pressures are known for what might be considered to be a single equivalent multi-sensor probe. Reference 1 shows how such pressures can be reduced to values of pitch, yaw, and magnitude of the velocity vector. The zero yaw angle must be found first by comparing the left- and right-hand sides of the type "A" probe output as a function of yaw.

As shown in Appendix B, the type "A" probe output as a function of yaw angle in a steady uniform flow is symmetrical about a position where the probe is aligned with the flow (referred to as the zero yaw position). If in an unknown flow the yaw angle is not zero, by rotating the probe and

finding two equal pressure readings separated by a certain angle difference and selecting the mid-point between the two corresponding angles, the unknown yaw angle can be determined. This procedure is in principle the same as the pneumatic balancing of a conventional probe (see Ref. 1). However, in an actual measurement situation the pressure output is not given as a continuous function of yaw angle. In practice, the data acquisition system allows digital recording of data for 5 to 11 different probe yaw angles. Figs. 3(a) and 3(b) give a comparison of calibration data and an approximation using a fourth-order polynomial for nine data points. It is evident that the characteristics of the probes allow a good representation of their output to be obtained for $P_A = P_A(\alpha)$ and $P_B = P_B(\alpha)$ ($\alpha =$ yaw angle) if only a few values are given. From these analytic functions the values $P_{A \max}$ (maximum output of the "A" probe), $P_{B \max}$ (maximum output of the "B" probe) and a value P_{SA} can be determined very easily. P_{SA} is found from $P_A = P_A(\alpha)$ where a difference in yaw of 126° separates right and left branches. This difference is chosen because for $\pm 63^\circ$ of yaw the type "A" probe output corresponds closely to static pressure.

Details of the methods used to derive the pitch angle and Mach number from the values of $P_{A \max}$, P_{SA} and $P_{B \max}$ will be discussed later in detail.

In acquiring data from the compressor at a steady operating condition, for each of 128 positions in the blade-to-blade

direction across a selected blade passage, pressure data are acquired from the two probes set at 5 to 11 probe yaw angles. Thus at each blade-to-blade position $P_A = P_A(\alpha)$ and $P_B = P_B(\alpha)$ can be approximated and yaw and pitch angles and Mach numbers can be derived.

3. SECOND GENERATION PROBES

In order to improve spatial resolution and keep effects such as the probe stem interference as small as possible, a new set of Kulite probes was built.

3.1 Probe Design

The so-called second-generation probes incorporate Kulite semi-transducers of the type XC062. The transducers measure 0.062 inches in diameter and are roughly two-thirds of the size of the first generation transducers. Figure 4 shows the probes in detail. The other difference compared to the first probes is the angle of the tip of the "B" probe; it is at 35° rather than 55° with respect to the zero axis. The reason is that for a range of 30° to 50° angle of attack the relationship between pressure output and angle of an inclined pressure probe is almost linear, while for higher angles it can reach a minimum and become double valued. An angle of 35° should give good resolution for pitch angles in the range of -5° to $+15^\circ$.

The probe tips are covered with machined caps which have eight holes arranged in a circle. This way the area where the transducers are located is shielded while there is still sufficient area for the air to get into and out of the minute volume above the membrane. A frequency response in excess of 100 Khz is retained when the screen is used.

3.2. Temperature Sensitivity

High response semiconductor transducers are generally sensitive to temperature changes. That is, changes in the temperature of the surrounding medium will produce changes in the indicated pressure although there has been no change in the pressure level. In the transducer manufacturer's specifications it is quoted that a change of 100°F might result in a misreading of as much as 2% of the full range (25 PSI) of pressure. On request the transducers can be built so that only 0.5% misreading for the same conditions should result. Thus a 100°F temperature change should produce no more than 0.125 PSI or--equivalently--3.46" H₂O misreading.

The relationship between transducer voltage output and pressure is known to be linear (Refs. 2 and 3). Temperature changes result mainly in a shift of the intercept rather than the slope of the linear relationship. Since the temperature of the flow in the compressor is expected to be about 50°F higher than ambient, an error of 1.7" H₂O might be expected to be present in the pressure measurement if no account was taken of the temperature sensitivity, assuming the manufacturer's specification to be accurate.

A simple test was made to check the temperature sensitivity of the "B" probe. The probe was inserted into a container which was vented to atmospheric pressure but which could be heated. With the probe connected to the data

acquisition system in the usual way, the container temperature was changed and the voltage output of the probe was recorded. Figure 5 shows the effect of a temperature change of about 60°F over a period of four minutes. A corresponding increase of some 2.4" of water in the indicated pressure was observed, corresponding to about 0.6% of the full transducer range for a temperature change of 100°F. This was consistent with the sensitivity quoted by the manufacturer.

For an average flow Mach number in the compressor of 0.7, with a corresponding dynamic head of 154 inches of water, an apparent shift in the transducer intercept of 1 to 2 inches of water is not large. Also, since the shift would be similar at different probe angles (assuming the transducer temperature would not change significantly), measurements based on differences between pressures from the same probe set at different angles, would be little affected. However, as readings from the "A" and "B" probe are both involved in calculating the pitch angle, the probes must give absolute pressure levels accurately. Therefore there is need for on-line calibration as data is acquired at any new test condition.

4. PROBE CALIBRATION

4.1. Calibration Procedure

The range of Mach number, pitch and yaw angle over which the probes were calibrated, had to cover the ranges which were expected in the compressor measurements. The freejet used for the calibration, which is described in Ref. 1, is capable of Mach numbers up to 0.9, pitch angles from -45° to $+45^{\circ}$ and yaw angles from 0° to 360° . Figures 6(a), (b) and (c) show details of the probe hook-up and instrumentation which was used. Table I gives the input/output assignment list for the data acquisition system.

The "A" and "B" probes were calibrated separately. The probe outputs were each recorded for a total of 9 pitch angles (-15° to $+25^{\circ}$ in 5° increments) and 6 Mach numbers (0.2 to 0.7 in 0.1 increments). For each of these 54 configurations the probes were yawed from -80° to $+80^{\circ}$, as data were continuously recorded. This procedure served to establish the complete pressure vs. voltage output characteristics of the probes, information to be used later in the analysis and interpretation measurements in the compressor.

The transducers were scaled using bridge adjustments to give engineering units on the DVM. The angle potentiometer was set to read linearly in increments of 0.1° .

The Kulite transducers were scaled to read in increments of .01 inches of water, differential pressure. The slope and intercept of the Kulite transducer were checked and adjusted as necessary before taking data at each new test condition. The intercept was adjusted to zero by applying the jet reference stagnation pressure to the reference side of the probe transducer with the probe tip aligned with the flow and balancing the transducer bridge. The slope was set by adjusting the output of the transducer to be equal to the jet stagnation pressure with atmospheric pressure as reference.

For each configuration of probe, Mach number, and pitch angle, the procedure was as follows:

- (i) Reference measurements for the jet (stagnation pressure and temperature, and ambient pressure) were recorded.
- (ii) The probe was swept steadily from -80° to $+80^{\circ}$ yaw angle as 150 data values of both probe voltage output and yaw angle potentiometer reading were acquired by the computer (Fig. 6). The jet reference measurements were recorded again.
- (iii) The procedure in (ii) was repeated but with the probe yaw angle swept back from $+80^{\circ}$ to -80° .

The three sets of reference measurements were compared to verify the steadiness of the test conditions. When all data were taken, a printout was produced on the line printer and a plot of pressure versus yaw angle was generated on the X-Y plotter.

For each probe, the procedure in (i)-(iii) was repeated for each pitch angle with the jet Mach number fixed. The jet Mach number was then adjusted to the next value and the complete procedure repeated again.

4.2. Data Acquisition and Storage

For each of the 54 configurations a total of 640 numbers were stored in one data file as a 2 by 320 array. The computer program used for the data acquisition was &KALIB (on cartridge 26, FORTRAN IV). The program is listed in Appendix C together with program &YAW (on cartridge 26, FORTRAN IV). Both programs (&KALIB and &YAW) are acquisition programs for the calibration of type "A" and "B" probes. The difference is that program &YAW records--in a more conventional way--data from one fixed yaw position as the average of ten readings for up to 31 positions, while program &KALIB gathers data for continuously varying yaw position.

It was found that the average of multiple samples taken at a fixed yaw position did not give more accurate results than a single reading. Figure 7 shows a comparison between the output obtained with the two different data acquisition methods. The good agreement is an indication of the steadiness of the flow in the free jet. Figure 8 shows the output of a total pressure Kulite probe held fixed in the jet over a period of 4 minutes, during which 1000 single readings were recorded. The

largest disturbances shown in Fig. 8 are probably the result of distinct changes in the ambient pressure resulting from doors being opened or closed in the building, rather than fluctuations in the jet itself.

The data acquisition program &KALIB is fairly simple and contains explanations in the program listing. Details of the data arrangement in the array are given in the program listing (Program &KALIB, statement numbers 46 through 77).

4.3. Type "A" Probe Results

Figure 9 gives an example of the type "A" probe data output at fixed Mach number for each of nine pitch angles. Shown is the probe voltage output versus yaw angle. Such plots provided a visual check of the acquired data. Table II gives an example of the data recorded for one Mach number and one pitch angle for the "A" probe. All the data in Table II are stored in one file for each configuration. Table III gives a guide to the data files for the "A" probe calibration. They are stored on cartridge 26. The file names follow the following logic:

X Y K Z R R

where

X = A for the "A" probe, or = B for the "B" probe

Y = 2, 3, 4, . . . --Mach number x 10

K = K, Kulite

Z = P for positive or = N for negative pitch angle

RR = 15, 10, 05, etc., = magnitude of the pitch angle

All data taken for the "A" probe appeared to be well behaved and useful throughout.

4.4 Type "B" Probe Results

First measurements with the "B" probe showed poor to unusable results. The output of the probe as a function of yaw angle was unsymmetrical for positive or negative yaw angles. Figure 10 shows the output at one Mach number, for the full range of pitch angles. An investigation of the probe tip under the microscope showed that some of the holes in the protective screen at the probe tip were partially blocked by particles of dirt or glue (Fig. 11(a), and (b)). The holes were cleaned and the calibration rerun. Figure 12 shows the results at a Mach number of 0.4. The characteristics of the probe were seen to be much improved and satisfactory for the intended application. Table IV gives the list of the data file names as stored on cartridge 26.

4.5. Calibration Data Analysis

For the "A" probe the output of the probe as a function of yaw angle $P_A = P_A(\alpha)$ was analysed for each of the combination of Mach number and pitch angle. First, the maximum value, $P_A \text{ max}$, was calculated as the maximum value of a fourth-order polynomial curve fit in the

$-20^\circ \leq \alpha \leq 20^\circ$. Over this limited range the curve $P_A = P_A(\alpha)$ was fairly flat and a very precise determination of the maximum value was possible. Second, to establish values of P_{SA} for each curve, (see Section 2), the data were surveyed to find the yaw angle closest to -63° . Data at this and at four values above and four values below this particular yaw angle were approximated with a second-order polynomial and the corresponding value of P_A , designated P_{SAL} yaw was calculated. A second-order polynomial approximation for this part of the curve was adequate since the characteristic was nearly linear in this range (see also Appendix B). The same procedure was used for the right hand side of the characteristic to establish the value, P_{SAR} , at a yaw angle of $+63^\circ$. The two values were found to be the same to within a small deviation for all 54 configurations. The value of P_{SA} was calculated as the average of P_{SAL} and P_{SAR} . Figure 13 is an illustration of the data reduction.

The only data needed from the "B" probe was the maximum pressure output at each test condition. This value always occurred for a yaw angle of zero degrees when the flow was aligned. The maximum was found by approximating the output values of P_B over the yaw angle range $-30^\circ \leq \alpha \leq 30^\circ$ with a fourth-order polynomial and solving for zero slope. The corresponding yaw angle was found to be very close to zero for all 54 configurations.

Figure 14 shows a curve $P_B = P_B(\alpha)$ for one Mach number and one pitch angle with the value established for $P_B \text{ max}$.

The values of $P_{A \text{ max}}$, P_{S_A} , and $P_{B \text{ max}}$, so derived, were considered to be analogous to the outputs of a conventional pneumatic multi-sensor probe. The calibration and reduction of measurements to values of Mach number and pitch angle (the yaw angle was always zero) could be handled in exactly the same way as was done for the combination temperature-pneumatic probe (see Ref. 1). The dimensionless velocity, X , was used instead of the Mach number, M where X is defined as $X = \frac{V}{V_t}$ where $V_t = \sqrt{2 C_p T_t}$, the "limiting" velocity. The quantity X can be expressed in terms of Mach number as

$$X = \frac{\frac{\gamma-1}{2} M^2}{1 + \frac{\gamma-1}{2} M^2}$$

For each of the 54 test conditions, using the values $P_{A \text{ max}}$, P_{S_A} , and $P_{B \text{ max}}$, the coefficients β and γ were calculated where

$$\beta = \frac{P_{A \text{ max}} - P_{S_A}}{P_{A \text{ max}}} \quad (1)$$

$$\gamma = \frac{P_{A \text{ max}} - P_{B \text{ max}}}{P_{A \text{ max}} - P_{S_A}} \quad (2)$$

and a third coefficient, δ , was examined where

$$\delta = \beta \cdot \gamma$$

β is derived from values of the "A" probe only. The "A" probe is insensitive to pitch angle as long as it does not exceed $\pm 15^\circ$ to $\pm 20^\circ$. Hence γ provides the measurement of the pitch angle. The coefficients β , γ , and δ are discussed in detail in Ref. 1.

The data for a complete calibration are given in Table V. It can be seen that at fixed Mach number the value of β is always about the same regardless of the pitch angle while γ changes significantly with pitch angle. The changes in γ with changes in Mach number are seen to be small.

If X is expressed as a function of β and γ , $X = X(\beta, \gamma)$ and ϕ , the pitch angle is expressed as a function of β and γ , $\phi = \phi(\beta, \gamma)$ the functions $X(\beta, \gamma)$ and $\phi(\beta, \gamma)$ can be approximated with polynomials using the methods described in Ref. 6, such that

$$X = \sum_{i=1}^L \left\{ \sum_{j=1}^M C_{ij} \beta^{(j-1)} \right\} \cdot \gamma^{(i-1)}$$

$$\phi = \sum_{i=1}^L \left\{ \sum_{j=1}^M D_{ij} \beta^{(j-1)} \right\} \cdot \gamma^{(i-1)}$$

where C_{ij} and D_{ij} are constant coefficients. Figs. 15(a) and (b) show the surfaces which were obtained for $X(\beta, \gamma)$ and $\phi(\beta, \gamma)$, respectively.

The programs written to approximate $X = X(\beta, \gamma)$ and $\phi = \phi(\beta, \gamma)$, based on the subroutines given in Ref. 6, are &REST8 and &REST9. The programs are described in detail in Appendix D. It is noted that the coefficients were derived for the pitch angle expressed in radians.

A check of the approximation was performed in order to establish its quality. For the measurements of β and γ from the calibration X and ϕ were calculated using equations (3) and (4). The results were compared with the corresponding values known to have been set when the measurements were made. Errors in the dimensionless velocity, ϵ_X , and errors in the pitch angle, ϵ_ϕ , were defined as

$$\epsilon_X = \frac{X_m - X_c}{X_m} \cdot 100 \quad (5)$$

and

$$\epsilon_\phi = \phi_m - \phi_c \quad (6)$$

where the subscription m denotes the value measured or known to have been set and subscript c denotes the value calculated using the surface approximation.

The error ϵ_X is expressed as a percentage of the measured value while for the pitch angle the absolute difference in degrees between measurement and calculation is calculated. A percentage error in angle is meaningless close to **zero** pitch angle.

Table VI gives the coefficients obtained for the X and ϕ surfaces. Also shown are the errors ϵ_X and ϵ_ϕ obtained using equation (3) and equation (4). Approximations were derived for each of 36 possibilities consisting of combinations of first to sixth order approximation for β and first to sixth order approximation for γ .

The coefficients shown in Table VI gave the best results on average over the range of the calibration. They are stored as 7 by 7 arrays under the file names shown on cartridge 26. It is noted that the errors shown in Table VI are an indication only of the degree of accuracy of the approximation technique.

5. VERIFICATION TESTS

Two tests to evaluate the accuracy of the calibration and of the data reduction technique were made: (1) The raw data from the calibration were treated as test data and the reduction procedure to calculate X and ϕ was applied; (2) The probes were mounted together on the freejet, the flow was adjusted in Mach number and the two probes were set together to the same pitch angles, which were unknown to the operator (see 5.2.). Data were acquired at specific yaw angles and reduced as in the compressor application. The results are described in the following paragraphs.

5.1. Verification Using Calibration Data

From the calibration test, the pressures for the "A" and "B" probe were recorded for fixed Mach number and pitch angle as $P_A = P_A(\alpha)$ and $P_B = P_B(\alpha)$ for a range of yaw angle of $-80^\circ \leq \alpha \leq 80^\circ$. These distributions were each approximated using a sixth order polynomial, so that values P_A and P_B could be interpolated at any yaw angle. For the "A" probe 9 yaw angles were chosen ($\pm 65^\circ$, $\pm 45^\circ$, $\pm 30^\circ$, $\pm 15^\circ$, 0°) so that the range of yaw angle necessary to handle the data reduction was covered. Since for the "B" probe sufficient values are required to determine only the maximum output, 9 different yaw angles for a

relatively small range were chosen ($\pm 30^\circ$, ± 22.5 , $\pm 15^\circ$, $\pm 7.5^\circ$, 0°). Arrays PA(9) and YAWA(9) were generated to contain pressure and yaw angles respectively for the "A" probe and similarly PB(9) and YAWB(9) were generated for the "B" probe. These data were then in a format as if they were produced by the data acquisition program for compressor measurements, and could be reduced in the same way.

From the fourth order polynomial for the "B" probe data, the maximum value P_{Bmax} and yaw angle at which it occurred were stored, for each data set.

PA(9) vs. YAWA(9) and PB(9) vs. YAWB(9) were approximated using fourth order polynomials. For each data set the curve $P_A = P_A(\alpha)$ was searched for the yaw angles where the spread between left and right branches was 126° . Corresponding to definitions used in the reduction of calibration data, the pressure determined at the left branch was P_{SA_L} and the one at the right branch was P_{SA_R} . These pressures were as defined here, the same and were equivalently equal to the value P_{SA} (see Fig. 13). P_{Amax} was calculated using the fourth order polynomial $P_A(\alpha)$ at the value of yaw angle midway between the values corresponding to P_{SA_L} and P_{SA_R} .

β and γ were calculated using equations (1) and (2) for each data set. Using these values, the coefficients from data files MISTXV and MISTIFI and the equations (3)

and (4), the corresponding values of X and ϕ were computed. The yaw angle was taken to be that corresponding to the value P_{Bmax} because the "B" probe had a clearly defined maximum whereas the "A" probe did not (see Figs. 13 and 14). The values so obtained for X , ϕ , and α using this reduction technique were compared to the corresponding values known to have been set and recorded during the test. Errors were calculated following equations (5) and (6). A third error, ϵ_α , for yaw was calculated using

$$\epsilon_\alpha = \alpha_m - \alpha_c \quad (7)$$

where α_m was the measured yaw angle and α_c was the yaw angle calculated from the "B" probe data. Since α_m was always zero during the calibration, the error ϵ_α so defined was equal to minus the value calculated in the reduction procedure.

The calculations described required extensive data handling. A program was written (EVALU) to read the two data files (for the "A" and "B" probes) and carry out the calculations. The program accesses and reduces data for one configuration (Mach number and pitch angle) at a time. It prints the calculated and measured values and the errors defined in equations (5), (6), and (7) before returning automatically to read the files for data from the next configuration. Program EVALU is described in detail in Appendix E.

Table VII shows a comparison of the measured and calculated data. Values for Mach number from 0.3 to 0.7 and pitch angle between 0° and 15° are given since these are the range of values expected in the intended application. The average error in X (or velocity) was about -0.4% with a maximum value of -1.336%. The average pitch angle error was 0.12° with a maximum value of 1.36° . An average yaw angle error of 0.6° was obtained with a maximum error of -1.16° . Figure 16(a), (b) and (c) show these errors plotted as functions of Mach number and pitch angle. No significant trends were detected in these data except perhaps in ϵ_0 . Table VII shows that the yaw angle error was always negative at an average magnitude of roughly half a degree. This is probably an indication of the fixed error involved in mounting the probe on the freejet.

It should be noted that the probe mounting used on the freejet and on the compressor were not the same. After the calibration and verification tests were made on the freejet, the probes were mounted in special actuators for use on the compressor. First however, the assembled probe and actuators were mounted in turn on a six foot long, four inch diameter pipe which was fed by the laboratory air supply. In this pipe, due to its length to diameter ratio, a steady symmetrical airflow parallel to the pipe centerline was assured. For

different Mach numbers--pitch angle was constrained to zero degrees--each probe was yawed about its tip to either side. By comparing left and right branches of the indicated probe output the yaw angle vernier was set to zero at the point of symmetry, corresponding to aligned flow. The probe was secured in the actuator so that for compressor measurements, zero yaw corresponded precisely to alignment with the axial flow direction through the machine.

5.2. Verification on the Freejet

In order to verify the probe calibration and data reduction in a known flow, the probes were mounted together on the freejet. Only the yaw angle of one probe (the "A" probe) could be read using the data acquisition system. The probes were displaced peripherally at an angle of 90° to each other (see Fig. 6). While the tip of the "B" probe was on the centerline, the tip of the "A" probe was retracted radially about one inch from the centerline to avoid flow interference between the probes. Both probes were mounted on the same type of pitch angle adjustment device.

In the test procedure the probes were set in unison to controlled pitch angles and Mach numbers which were unknown to the operator. At each setting, the two probes were each rotated to 9 different yaw angles ($\pm 65^\circ$, $\pm 45^\circ$, $\pm 30^\circ$, $\pm 15^\circ$, 0°). Data were taken for each of the 9 yaw

positions. The pressure readings recorded were the average of 10 successive samples. Before the actual test the zero drift of the sensors was checked. For the "A" probe this was done by comparing the probe output when set to zero pitch angle with pressure. For the "B" probe, the probe was set to -35° in pitch (see Fig. 4) and a similar comparison was made. The data taken were not stored but only printed. Appendix F contains the computer program TEST which acquired the data and performed the data reduction.

In order to check the yaw angle determined by the reduction procedure the probe yaw angle data were artificially offset. The 9 yaw positions recorded were changed by adding a constant to each: $65^{\circ}+X$, $45^{\circ}+X$, $30^{\circ}+X$, $15^{\circ}+X$, $0^{\circ}+X$, $-15^{\circ}+X$, $-30^{\circ}+X$, $-45^{\circ}+X$, $-65^{\circ}+X$. The data reduction procedure should then produce a value for the yaw angle equal to X.

Table VIII shows results of the verification tests. Shown are the results for values of Mach number and pitch angle which are typical of those to be expected in the compressor. The errors given in Table VIII are defined as

$$\epsilon_X = \frac{X_s - X_c}{X_s} \cdot 100$$

$$\epsilon_{\phi} = \phi_s - \phi_c$$

$$\epsilon_{\alpha} = \alpha_s - \alpha_c$$

where index s is the set condition and c the calculated value.

The values of ϵ_x , ϵ_ϕ , and ϵ_α obtained were considered to represent an acceptable accuracy for the planned application of the technique. In particular, the accuracy of the pitch angle measurement was encouraging. The pitch angle was of particular concern because the distribution of pitch behind the rotor was a particular goal of the intended measurements which could lead to important conclusions concerning the flow through the rotor. As shown in Tables VII and VIII, the errors in pitch angle measurement appear to be acceptable.

6. APPLICATION IN COMPRESSOR TESTS

Complete results of compressor measurements made with the probe system will be reported later. Some initial measurements are reported here to examine and illustrate the reliability and accuracy of the probe system and of the data reduction. Since the data acquisition in the compressor is more complicated than in calibration tests on the freejet, the procedures and the programs used are described in detail.

6.1. Necessity of an Online-Calibration

The semi-conductor transducers are, to some degree, sensitive to temperature change as well as to differential pressure change. If a relationship between differential pressure and voltage output of the transducer was established by calibration before the compressor was started, there would be no guarantee that this relationship would remain valid while the machine was running. A total temperature rise of 25°F occurs in flow through the rotor and the actual temperature of the probe itself must increase, but can never be known precisely. The magnitude of the probe temperature rise is large enough however that the change in the transducer's voltage/pressure relationship must be taken into account in some

way. This is done through online calibration.

6.2. Online Calibration

Although there is a temperature sensitivity, the relationship between the voltage output of the transducer and the differential pressure is found to be always linear (Ref. 2, 3). Thus, if e denotes the voltage output and ΔP the corresponding differential pressure, the equation

$$\Delta P = i + S \cdot e \quad (8)$$

describes the calibration, where i is the intercept and S is the slope.

The transducer is arranged in the probes such that any desired constant pressure, P_r , can be applied to the back, or reference side, of the transducer. The unknown pressure on the front of the transducer, P , which is varying in time, is given by $P = \Delta P + P_r$, or

$$P = i + S \cdot e + P_r \quad (9)$$

The on-line calibration procedure establishes values for the slope and intercept while the compressor is operating at the speed and flow rate at which probe data are required. The procedure to establish the slope is the same for both the Type "A" and Type "B" probes. The procedure for the intercept is more elaborate and quite different for the two probes. The procedures are described separately in the following paragraphs.

6.2.1. Procedure For Slope

At a given steady machine condition, the time average probe pressure, \bar{P} , is constant. Because of thermal inertia it is reasonable to assume that both the slope S and the intercept i are also constant, although unknown. If two different reference pressures, P_{r1} and P_{r2} , are applied to the transducer in turn, and the corresponding time-averaged output voltages \bar{e}_1 and \bar{e}_2 are recorded then, from equation (9),

$$\bar{P} = i + S \cdot \bar{e}_1 + P_{r1} \quad (10a)$$

and

$$\bar{P} = i + S \cdot \bar{e}_2 + P_{r2} \quad (10b)$$

combining these equations, it follows that

$$S = \frac{P_{r2} - P_{r1}}{\bar{e}_2 - \bar{e}_1} \quad (11)$$

Equation (11) provides the means to calculate the slope of the transducer from measurements. In practice four to five different reference pressures are applied and the slope is calculated as a linear approximation (by least squares) to the variation of \bar{e} vs. P_r .

6.2.2. Procedure For Type "A" Probe Intercept

The time averaged flow conditions in the measuring plane are established using the combination pneumatic and temperature probe reported in Ref.1. The probe determines values for the Mach number, pitch angle

and yaw angle*. The combination probe tip, with its arrangement of four pressure tubes, is shown in Fig. 17. When the probe is aligned to balance pressures P_2 and P_3 , the pressure referred to as P_1 is a measurement of the total pressure, since the flow pitch angle can not exceed about 11° at the rotor exit. Similarly, the type "A" probe when aligned at the time-averaged yaw angle is also in principle, a total pressure probe. By equating the measured pneumatic pressure P , to be equal to the time-average of the pressure seen by the type "A" probe, $\overline{P_A}$, the intercept of the "A"-probe can be calculated using equation (10)**.

Data for the calculation of the intercept was gathered during the acquisition of time-resolved flow

*The question of whether a pneumatic probe can measure the correct time-averaged values of fluctuating pressures, raised in Ref. 7 and Ref. 8, was addressed in Ref. 1. It was shown that for the conditions measured to date, the results of the combination probe were accurate. Nevertheless, the possibility that an increase in rotor speed, resulting in higher fluctuation pressure amplitudes and pressure ratios, might affect the accuracy of the pneumatic measurements is accepted; and close attention will be paid to it in the future.

**The "time-average" voltage could be recorded using the integrating DVM or by acquiring a large number of discrete samples at arbitrary intervals using the HP 5610 A/D converter and computing the average. In early tests, the samples for the time-average measurements were taken using the A/D converter in the so called "free-run" mode. Roughly 1500 single data samples were collected over about 15 msec. A comparison of the average values acquired this way with those given by a digital voltmeter consistently showed agreement to within $\pm 0.5\%$. Subsequently, for convenience, the DVM was used to acquire values of the time-averaged voltage S from the Kulite probes during the online calibration.

data. At each yaw angle to which the two probes were set, readings of the probe transducer outputs were recorded using the DVM. Data from the combination probe were acquired also; however, the probe's yaw angle was not changed. The DVM voltage readings from the "A" and "B" probes were approximated as functions of the corresponding yaw angles by fourth order polynomials, $\overline{e}_A = \overline{e}_A(\alpha)$ and $\overline{e}_B = \overline{e}_B(\alpha)$. The maxima of these functions were derived mathematically and designated $\overline{e}_{A\max}$ and $\overline{e}_{B\max}$ respectively.

The value $\overline{e}_{A\max}$ was found to exist at a flow yaw angle very close to the yaw angle measured with the combination probe. For the A probe, a pressure coefficient was defined as

$$\overline{C}_{PA0} = \frac{\overline{P}_{A\max} - \overline{P}_S}{\overline{P}_t - \overline{P}_S} \quad (12)$$

The index "0" indicates that the coefficient was derived for the yaw angle where the probe was aligned with the time-averaged flow. Ideally \overline{C}_{PA0} would be unity, since the "A" probe is expected to measure total pressure if properly aligned with the flow. However, during the calibration procedure (reported in Section 4) it was found that \overline{C}_{PA0} depended slightly on the probe pitch angle, although not on Mach number. As shown in Fig. 18, \overline{C}_{PA0} varies within the range of 0.990 to 1.020. The

relationship between $\overline{C_{PA0}}$ and pitch angle obtained in the steady-flow calibration was approximated by a fourth order polynomial. Using this approximation and the time-averaged pitch angle, stagnation pressure ($\overline{P_t}$) and static pressure ($\overline{P_S}$), $\overline{P_{Amax}}$ can be calculated using Equation (12).

Knowing the values $\overline{e_Amax}$, the slope s and the reference pressure (P_r), the intercept (i) of the A-probe can be calculated using equation (10). Thus the relationship between the probe and the time-varying voltage signal from "A" probe is known, using equation (9).

6.2.3. Procedure for Type "B" Probe Intercept

The determination of the intercept of the "B" probe is indirect. Unlike the "A" probe there is no matching pneumatic measurement for the "B" probe. Such an approach would be too inaccurate. The "B" probe is intended to be very sensitive to pitch angle changes, so that a very small difference in tip geometry of the Kulite and an "equivalent" pneumatic probe would cause a potentially large error in the calculation of the intercept. Thus an alternate way to derive the "B"-probe intercept was adopted.

During the online calibration procedure, the "A" and "B" probes are set to the same yaw angle as the combination probe. In this orientation, all three probes are aligned with the time-average flow vector. This flow vector is determined totally by the combination probe, and thus the yaw angle, pitch angle, Mach number, total and static pressures are known for the time-averaged conditions.

A pressure coefficient, $\overline{C_{PB}}$ can be calculated for the "B" probe using the definition

$$\overline{C_{PB}} = \frac{\overline{P_B} - \overline{P_S}}{\overline{P_t} - \overline{P_S}} \quad (13)$$

If the pressure reading of the "B" probe when aligned with the flow is referred to as $\overline{P_{Bmax}}$, the corresponding pressure

coefficient, \overline{C}_{PB0} , (at zero yaw angle of the probe with respect to the flow) is given by

$$\overline{C}_{PB0} = \frac{\overline{P}_{Bmax} - \overline{P}_S}{\overline{P}_t - \overline{P}_S} \quad (14)$$

From the calibration tests reported in Section 4, values of \overline{C}_{PB0} were determined for each of 54 combinations of Mach number and pitch angle. These data are given in Table IX. Figure 19 shows these calibration data for \overline{C}_{PB0} plotted as a function of Mach number and pitch angle. While the dependence on Mach number is seen to be small, a strong and well-behaved relationship between \overline{C}_{PB0} and pitch angle can be observed. \overline{C}_{PB0} was viewed as a function,

$$\overline{C}_{PB0} = \overline{C}_{PB0}(X, \phi) \quad (15)$$

The function in equation (15) was similarly approximated using the calibration data as a surface depending on two independent variables (Section 4.4). Appendix G describes the computer program used and illustrates the results.

Using the expression for the surface represented by equation (15), and values of the Mach number and pitch angle, given by the combination probe, at each operating point, \overline{C}_{PB0} were calculated. Then, using the time-averaged total and static pressures given by the combination probe measurement, a corresponding value of \overline{P}_{Bmax} can be calculated using equation (14). Using the recorded value of the

"B" probe voltage output, $\overline{e_B}_{\max}$, corresponding P_r , and the value established earlier for the transducer slope, the intercept of the "B" probe was calculated using equation (10). Thereafter, equation (9) could be used to convert time-dependent voltage readings to absolute pressure values.

6.3. Data Acquisition in TX-Compressor Measurements

The hardware of the dual probe digital sampling technique was described in Section 2. The present section describes the procedures and software used to acquire and store raw data necessary to determine blade-to-blade velocity distributions. The sequence of events is summarized in Table X.

As described in Section 2 and Section 4.5, at each blade-to-blade location sufficient data from the "A" and "B" probes were required that functions $P_A = P_A(\alpha)$ and $P_B = P_B(\alpha)$ could be established. However, the yaw angle was not known a priori for any of the 256 positions at which data were acquired. The time average yaw angle was known from the combination probe and variations in yaw angle were selected to be about this value.

It was found that yaw angle varied typically -5° to $+15^\circ$ from the time averaged value. Thus data were acquired for 9 different probe yaw angles covering a

range of the average yaw angle minus 5° minus 65° , and plus 15° plus 65° , in order to make sure that a sufficient range was covered to define the maximum values from

$$P_A = P_A(\alpha) \text{ and } P_B = P_B(\alpha) \text{ for } \alpha = \pm 63^\circ.$$

Program &ABKUL was used for the data acquisition. It is described in detail in Appendix A. Figures 20a and 20b show an output of the raw data. Shown are the outputs of "A" probe (Fig. 20 a + b) & "B" probe (Fig. 20 c + d) for all 256 positions and for the 9 different probe yaw angle settings. The plots were generated by program &WAVE which is described in Appendix I. Besides plotting data from a data file the program also offers the possibility to acquire data from one Kulite probe and plot it on-line.

All data acquired with program &ABKUL are stored in one large data file. This includes the unsteady measurement data, all the steady state data for the online calibration and the combination probe measurements. Thus each data set is complete and independent of any other information.

Table Xa shows an example of steady state data acquired for the online calibration (see Section 6.2.); values for the slopes of the Type A before (1st) and after (2nd) the paced data acquisition. This output allows comparison of the results of the two calibrations. If the corresponding values of slope differ by more than $\pm 1.5\%$, which indicates drift during the measurement

period, the data are not accepted. The "intercepts" of "A" and "B" probes are also printed. These values are only used however to monitor changes during the data acquisition. The actual intercept of the voltage-pressure characteristic must be calculated from these values as described in Section 6.2. Here again a difference of more than $\pm 1.5\%$ is taken as evidence that the transducer drifted during the measurement. The other data shown in Table X is raw data which is printed out immediately after it is acquired so that it can be checked. Combination probe data are always acquired with the Kulite probe data. Table Xb shows steady-state data taken with the data from the "A" and "B" probes. For each probe yaw angle setting the same data is acquired as for the online calibration. The values "yaw A pr." and "yaw B pr." give the probe yaw angle settings (nine positions). In the third column values DCA and DCB are printed. As described in Section 6.2., these are the dc voltage levels of the "A" and "B" probes which will be used for the determination of the intercept. For each of the nine positions, values called "averaged values paced output" for "A" and "B" probes are printed. Those are the averages of the 256 single measurements of each of the probes. A comparison of these values with the DCA and DCB values--if the decimal point is neglected--show differences of up to 5%. This is

because the DC values are derived for the whole rotor, while the paced output values are from two selected blade pairs only.

The single raw data file is arranged in a 20 by 256 array. Table XI shows the location of the data within that array. Column #1 contains the data for the online calibration only while column #20 is reserved for the steady state data acquired with paced data. Columns #2 through #19 contain the raw data for the nine yaw angle settings of the "A" and "B" probe, with the Type A probe data in even numbered columns, the Type B probe data in the odd numbers. Table XI also shows the hook-up for the data acquisition for the steady state data. This is explained in more detail in Appendix H. The data acquisition for one set of data including online calibrations and steady state data requires some 17 to 20 minutes.

6.4. Data Reduction

After the raw data is checked for obvious errors using program WAVE (see section 6.3.) the data reduction is carried out using a single program "ABRED". The steps in the procedure are listed in Table J-1 and Appendix J describes the program in detail.

The program first reads the coefficient files for the calibration of the A- and B-probe as well as those for the combination probe. The operator is then asked for some input concerning the amount of output that is desired. The first

calculation is to determine the flow time-average properties from the combination probe measurements. The average of the readings obtained at the nine different Kulite yaw angle settings is computed since the yaw angle of the combination probe was not changed during the acquisition sequence. The results shown in Table XII are values for dimensionless velocity (X), yaw angle, pitch angle, total pressure and static pressure.

The second calculation uses these values and the acquired raw data for the online calibration to compute the intercept values of the "A" and "B" probes. It is at the user's discretion to output the steps in this process in order to check the calculations performed (see Appendix J).

The first reduction of Kulite data performed is for the time-averaged values from Kulite probe measurements. A DC voltage reading of both probes was recorded for each of the nine yaw angle positions the probes were set to. Using the results of the previously performed online calibration, absolute pressure values are calculated. These are placed in two arrays, PAA(9) and PAB(9). Arrays YAWA(9) and YAWB(9) are filled with the corresponding yaw angle values. Using fourth order polynomials a relationship is approximated giving pressures of "A"- or "B"-probe as functions of yaw angle. From these functions the values $P_{A \max}$, P_{S_L} , P_{S_R} , P_{S_A} and $P_{B \max}$ are derived as shown in 4.5. The flow yaw angle was assumed to be the one corresponding to $P_{B \max}$. However, it should be mentioned that the flow yaw angle derived from the A-probe

as the center value between the yaw angles corresponding to P_{S_L} and P_{S_R} deviates only slightly ($\pm 0.5^\circ$ to $\pm 1.0^\circ$) from the one found with the B-probe.

From these four pressures, coefficients β , γ and δ are calculated. Applying the calibration coefficients to these values X-- or Mach number -- and pitch angle are calculated. Thus the time average flow vector is determined. If it is compared to the one derived from the combination probe measurement, the differences turn out to be, typically

0.64% in Mach number

0.55° in pitch angle

0.63° in yaw angle

The magnitude of these differences is acceptable. Table XII shows results of an actual data set from a compressor test run. At the very top values calculated from combination probe measurements are displayed followed by the results of the online calibrations for both "A" and "B" probe. Immediately thereafter the contents of the arrays PAA(9), PAB(9), YAWA(9) and YAWB(9) are given showing the average pressure values of both Kulite probes and their corresponding yaw angles for the overall flow measurement. The values P_{S_L} , $P_{A \max}$ and P_{S_R} derived from those are shown as well as the corresponding yaw angles. Next $P_{B \max}$ and the yaw angle for this pressure is given.

In the following line the actual flow quantities as derived from the "A"- "B" probes are listed. XU, XAX and

BETA2 are calculated from X, pitch and yaw angle, the circumferential speed and axial speed are printed also.

These values are:

XU = Circumferential speed (dimensionless)

XAX = Axial speed (dimensionless)

BETA2 = Relative flow angle in the measuring plane.

Once the overall flow vector is determined from the Kulite probes and compared to the results from the combination probe, individual measurements are reduced for any or all of the 256 positions. Whether all, one or any set of positions is reduced is operator-controlled by input parameters.

The same way the data reduction was carried out for the time-average flow vector the raw data for all 256 single positions are treated. Arrays PA(9) and PB(9) are filled with nine individual pressures of "A" and "B" probe which were derived from the raw data applying the results from the online calibration. The yaw angle settings YAWA(9) and YAWB(9) are the same nine values as before. Those are the same throughout the whole reduction since they are the ones the probes were set to. In Table XII the arrays of P_A , P_B , YAWA and YAWB are shown. Also given are arrays PAC(9), DPA, PBC(9), DPB. As mentioned previously P_A and P_B are approximated as functions of yaw angle by fourth order polynomials. In order to check the quality of that approximation, using the polynomials, values are calculated for the nine given yaw angles (PAC(9) and PBC(9)) and the difference between the measured pressure

value P_A or P_B and the calculated value PAC or PBC is displayed as DPA or DPB. As long as the values DPA and DPB are smaller than ± 2 inches of water (all pressures shown are in inches of water), it can be assumed that the approximation fits the data points sufficiently well.

Above the array of measured data are some reduced values. Again P_{S_L} , $P_{A \max}$ and P_{S_R} are printed with their corresponding yaw angles. Below the array, $P_{B \max}$ and the flow angle for this particular position are given. In the last line position number, beta, gamma, X-- or Mach number --, pitch angle and yaw angle for this position are given.

If a data reduction shall be performed for all 256 positions it is advisable to skip the print-out of the raw data and all intermediate steps (primary input). This way there will be only the print-out of the last line of Table XII for each of the positions.

6.5 Data Presentation and Evaluation

In chapter 6.4 the reduction procedure of the raw data to discrete values of X - (or Mach number), pitch angle and yaw angle for all or any of the 256 positions of measurement was described. All these flow parameters were stored in a single file and can be retrieved at any time. In order to get an idea of the flow behavior with respect to the rotor, the flow parameters were plotted as a function of the position within the rotor frame. Figure 21(a) shows the distribution of X ; Fig. 21(b) gives the yaw angle and Fig. 21(c) the pitch angle distribution. The programs used to generate these plots, namely PLOTX, PLOTY and PLOTP, are described in Appendix L.

The general behavior of the measurements was examined. For this, the assumption was made that the relative flow angle at the rotor trailing edge, β_2 , was constant for a given radius (see Fig. 22). Figure 23 shows the velocity triangles for the flow leaving the rotor. If β_2 and X_u , the circumferential velocity, are constant, any change in the Mach number of the relative flow will reflect in a change of yaw angle and Mach number of the absolute flow. Using the nomenclature in Fig. 23, at any given flow condition i the absolute velocity is given by

$$X_{v_i} = \frac{X_{u_a}}{\tan \beta_2 \cdot \cos \alpha_i + \sin \alpha_i} \quad (16)$$

Figure 24 shows X_{v_i} as a function of yaw angle. To be examined is the yaw angle corresponding to the minimum value of X_{v_i} . From Fig. 23 it can be seen that this yaw angle is $(90^\circ - \beta_2)$ which is indicated also on Fig. 24. Looking at Fig. 21(b) it was found that indeed the minima of X_{vel} correspond to a yaw angle of 39.11° .

Another characteristic point in Fig. 21(b) is the maximum value (48°) of the yaw angle. When X_{vel} was derived from equation 16 and from Fig. 24 for that yaw angle, a value of .1572 was obtained. This value was found to be consistent with the measured Mach number for that particular location.

7. DISCUSSION AND CONCLUSIONS

As pointed out in chapter 6.2 the absolute accuracy of the Kulite measurements is governed by the accuracy of the combination probe measurements. At higher Mach numbers yet to be measured, this may become a problem (see Ref. 1). Reference 7 shows that the pneumatic measurement might be incorrect if the fluctuations in pressure increase in amplitude beyond certain limits. Since the experiments of Ref. 7 were carried out using a totally different set-up for measurements of total and static pressures, the results are not directly comparable, however, an examination of the possible influence of such errors was attempted.

The assumption was made that P1 should be treated like a total pressure probe and P23 and P4 like static pressure probes. It was assumed that an error in the measurements of P1 and also in P23 and P4, or in P1 or P23 and P4 would occur at the same time, giving a total of three possible combinations.

An error of 10% defined according to Ref. 7 was assumed. Such an error resulted in an error of 0.25% in the absolute value of the total pressure and 0.5% in the static pressure. These errors applied to the data from data file AB1901 resulted in none of the three error combinations giving a significant change in Mach number and yaw angle distribution. The pitch angle showed the only significant dependence on these assumed errors. Figure 25 shows the comparison of calculated pitch

angle distribution with and without assumed errors. It can be seen that the biggest error was found for the case of a correct total pressure, but an incorrect static pressure (P23 and P4). An average difference of about one degree was found, and the distribution did not show any qualitative differences. Since the pitch angle could also be measured 0.5° too low (if P1 is measured incorrectly but P23 and P4 are measured correctly), the achievable accuracy of the pitch angle measurement is within a range of -0.5° to $+1.0^\circ$.

The basis of the method of application in the compressor is that the behavior of the probes as a function of yaw angle at each point in the rotor frame is the same as in a steady flow at the corresponding Mach number and pitch angle. The steady flow characteristic is known from the calibration. In order to examine the validity of this assertion, probe measurements were analysed for selected points of measurement with respect to the rotor frame. It was found that the B-probe produced the same characteristic P_B vs. yaw angle in its application as it did in its calibration. The type A probe however showed different results depending on the location of measurement. Figure 26 shows the output of the A probe reduced to values of C_{P_A} plotted in comparison with the curve of C_{P_A} as a function of yaw angle established during the calibration. It can be seen that for the time average values the agreement between test data and the calibration is very acceptable. It

is also acceptable for data from near mid passage. However, the same is not true for data in Fig. 26 from the rotor wake region. Going into the wake and out of it tends to skew the top of the function C_{p_A} vs. yaw angle to different sides of the actual flow yaw angle. Near the center of the wake the probe characteristic appears to be similar to that established in the calibration. Four possible explanations for the skewing are considered:

- a) Flow temperature effect on the probe output depending on the different probe yaw angle settings.
- b) Probe interference due to "steady" gradient effect.
- c) Probe interference due to "unsteady" gradient effect.
- d) "Incorrect" averaging in a flow in which Mach number and flow angles are separately unsteady, and probe output is non-linear in M , α and ϕ .

The effect in (a) is not a probable explanation since the effect would be present also in positions outside the wake. It is also unlikely, because of thermal lag, that the sensor material could respond to the high frequencies of the wake fluctuations. The effect in (b) could give errors having the observed qualitative behavior.

In Ref. 9 it is shown that when a velocity gradient strikes a total pressure probe the apparent location of measurement tends to shift away from the center of the probe tip. The calculations carried out in Ref. 9 were applied to the geometry of the probes and flow parameters measured in the blade wakes

with the A-B probes. It was found that an apparent displacement of the order of 3% of the probe outer diameter was indicated to be possible. This was considered to be negligible. However, since the results in Ref. (a) were for impact probes at zero yaw angle to the flow direction, an experiment to verify the conclusion for the A-B probes yawed in a velocity gradient, is certainly desirable.

The possibility of an unsteady error which results from the behavior of the probe itself must be considered. However, it is noted that the error is only significant where the flow is unsteady in the rotor frame. This explanation would have to be accepted if all other explanations failed, and could be verified by independent non-intrusive measurements such as LDV. However, since the error appears only in the unsteady wake the most probable cause is thought to be (d).

The existence of unsteadiness of flow parameters in the wake region is clearly evident from oscilloscope observations. The observed fluctuations are oscillations in the probe output voltage (pressure) readings, which--in the data acquisition process--are ensemble-averaged over 40 samples to represent one value of pressure for a single measurement.

From the average pressure values, pressure differences and ratios are derived and reduced to obtain a velocity vector calculated in this way is the same as the average flow velocity vector. The question clearly, is whether the flow velocity vector calculated in this way is the same as the average flow velocity vector which could be obtained if the actual velocity

vector was known for the individual samples. Clearly, the probe output depends quite differently on variations in pitch, yaw and Mach number, and the fluctuations involve changes in all three.

A first attempt was made to examine the problem of averaging. Using calibration data, an array of three Mach numbers, three pitch angles and three yaw angles was selected. This resulted in a total of 27 possible flow vectors, for which the functions $P_A = P_A(\alpha)$ and $P_B = P_B(\alpha)$ were known. Since the flow yaw angle during a calibration is always zero, an "artificial" yaw angle was superimposed on the calibration data. For yaw angles different from zero, corresponding pressure values for the A and B probes were shifted by the amount of the superimposed yaw angle, but in the opposite direction.

In a first step the 27 flow vectors were averaged by averaging their velocity components U, V, W and calculating the corresponding single values for pitch angle, yaw angle and Mach number. Secondly, for each of the 27 vectors, data sets PA(9) and PB(9) (corresponding to nine different probe yaw angles) were built. These values were averaged to result in nine single values for PA, PB and corresponding yaw angles. The regular data reduction procedure was then applied and pitch angle, yaw angle and Mach number were calculated.

Differences between the two calculation methods were defined as:

$$\epsilon_X = \frac{X_{af} - X_{ap}}{X_{af}} \cdot 100$$

$$\epsilon_\phi = \phi_{af} - \phi_{ap}$$

$$\epsilon_\alpha = \alpha_{af} - \alpha_{ap} ,$$

subscript "af" meaning average from flow vectors and "ap" meaning average from pressure values.

The procedure was carried out for four different sets of data, each consisting of 27 different flow conditions.

Table XIV lists the range within which each of the flow parameters was varied and the differences resulting from the calculations. The differences obtained were not large, however it must be noted that the process of averaging which has been tested does not exactly simulate the one to which the A-B probes are subjected in the compressor. Further analysis is required to properly evaluate the effect of averaging on the probe data. In order to explain the skewing observed in the A-probe output in the wake regions, it would only be necessary to have fluctuations which were not symmetric with respect to the wake centerline, as is very likely to be the case in the wake of a highly loaded compressor blade.

In conclusion, the DPDS technique has been developed further to successfully measure three components of velocity in regions outside the unsteady rotor wake. The edges of the wake region and average conditions on the wake centerline are well defined. A limitation to the use of the present method within the wake region is thought to be due to the necessity for ensemble averaging. Further work is planned to resolve this question.

TURBOPROPULSION LABORATORY
 HP9830/21 MX Data Acquisition
 Port/Channel Assignments

Test A-B-Calibration
 Run No. 1
 Date Jan 1982

S.V. #	S.V. #	SCANNER #1		SCANNER #2	
		ch		ch	
1		0		0	40
2		1		1	41
3		2		2	42
4		3		3	43
5		4		4	44
6		5		5	45
7		6		6	Tt Tunnel
8		7		7	47
9		8		8	48
10		9		9	49
11		10		10	50
12		11		11	51
13		12		12	52
14		13		13	53
15		14		14	54
16		15		15	55
17		16		16	56
18		17		17	57
19		18		18	58
20		19		19	59
21		20		20	Pt Tunnel
22		21		21	Kulite ref pres
23		22		22	Yaw Angle
24		23		23	Kulite press.
25		24		24	64
26		25	p baro	25	65
27		26		26	66
28		27		27	67
29		28		28	68
30		29		29	69
31		30		30	70
32		31		31	71
33		32		32	72
34		33		33	73
35		34		34	74
36		35		35	75
37		36		36	76
38		37		37	77
39		38		38	78
40		39		39	79
41					
42					
43					
44					
45					
46					
47					
48					

Table I. Data Acquisition System Hook Up.

TUNNEL PRESS		POINTS 400		POINTS 400		F RATIO INCHES 40		AFTER RECALIBRATION	
102.4952800		46.3088450		- 2710300		30.1000000		SET FOR RECALIBRATION	
102.4974360		46.1999770		- 2710300		30.1000000		AFTER RECALIBRATION	
102.4958000		46.2000050		- 2710333		30.1000000		AVERAGE VALUES	
44.79700	61	44.79700	61	44.79700	61	44.79700	61	44.79700	61
44.79700	62	44.79700	62	44.79700	62	44.79700	62	44.79700	62
44.79700	63	44.79700	63	44.79700	63	44.79700	63	44.79700	63
44.79700	64	44.79700	64	44.79700	64	44.79700	64	44.79700	64
44.79700	65	44.79700	65	44.79700	65	44.79700	65	44.79700	65
44.79700	66	44.79700	66	44.79700	66	44.79700	66	44.79700	66
44.79700	67	44.79700	67	44.79700	67	44.79700	67	44.79700	67
44.79700	68	44.79700	68	44.79700	68	44.79700	68	44.79700	68
44.79700	69	44.79700	69	44.79700	69	44.79700	69	44.79700	69
44.79700	70	44.79700	70	44.79700	70	44.79700	70	44.79700	70
44.79700	71	44.79700	71	44.79700	71	44.79700	71	44.79700	71
44.79700	72	44.79700	72	44.79700	72	44.79700	72	44.79700	72
44.79700	73	44.79700	73	44.79700	73	44.79700	73	44.79700	73
44.79700	74	44.79700	74	44.79700	74	44.79700	74	44.79700	74
44.79700	75	44.79700	75	44.79700	75	44.79700	75	44.79700	75
44.79700	76	44.79700	76	44.79700	76	44.79700	76	44.79700	76
44.79700	77	44.79700	77	44.79700	77	44.79700	77	44.79700	77
44.79700	78	44.79700	78	44.79700	78	44.79700	78	44.79700	78
44.79700	79	44.79700	79	44.79700	79	44.79700	79	44.79700	79
44.79700	80	44.79700	80	44.79700	80	44.79700	80	44.79700	80
44.79700	81	44.79700	81	44.79700	81	44.79700	81	44.79700	81
44.79700	82	44.79700	82	44.79700	82	44.79700	82	44.79700	82
44.79700	83	44.79700	83	44.79700	83	44.79700	83	44.79700	83
44.79700	84	44.79700	84	44.79700	84	44.79700	84	44.79700	84
44.79700	85	44.79700	85	44.79700	85	44.79700	85	44.79700	85
44.79700	86	44.79700	86	44.79700	86	44.79700	86	44.79700	86
44.79700	87	44.79700	87	44.79700	87	44.79700	87	44.79700	87
44.79700	88	44.79700	88	44.79700	88	44.79700	88	44.79700	88
44.79700	89	44.79700	89	44.79700	89	44.79700	89	44.79700	89
44.79700	90	44.79700	90	44.79700	90	44.79700	90	44.79700	90
44.79700	91	44.79700	91	44.79700	91	44.79700	91	44.79700	91
44.79700	92	44.79700	92	44.79700	92	44.79700	92	44.79700	92
44.79700	93	44.79700	93	44.79700	93	44.79700	93	44.79700	93
44.79700	94	44.79700	94	44.79700	94	44.79700	94	44.79700	94
44.79700	95	44.79700	95	44.79700	95	44.79700	95	44.79700	95
44.79700	96	44.79700	96	44.79700	96	44.79700	96	44.79700	96
44.79700	97	44.79700	97	44.79700	97	44.79700	97	44.79700	97
44.79700	98	44.79700	98	44.79700	98	44.79700	98	44.79700	98
44.79700	99	44.79700	99	44.79700	99	44.79700	99	44.79700	99
44.79700	100	44.79700	100	44.79700	100	44.79700	100	44.79700	100

Table II. Raw Calibration Data From A-Probe, One Mach Number, One Pitch Angle.

0.7	A7KP25	A7KP20	A7KP15	A7KP10	A7KP05	A7KP00	A7KN05	A7KN10	A7KN15
0.6	A6KP25	A6KP20	A6KP15	A6KP10	A6KP05	A6KP00	A6KN05	A6KN10	A6KN15
0.5	A5KP25	A5KP20	A5KP15	A5KP10	A5KP05	A5KP00	A5KN05	A5KN10	A5KN15
0.4	A4KP25	A4KP20	A4KP15	A4KP10	A4KP05	A4KP00	A4KN05	A4KN10	A4KN15
0.3	A3KP25	A3KP20	A3KP15	A3KP10	A3KP05	A3KP00	A3KN05	A3KN10	A3KN15
0.2	A2KP25	A2KP20	A2KP15	A2KP10	A2KP05	A2KP00	A2KN05	A2KN10	A2KN15
Mach Pitch	25	20	15	10	5	0	-5	-10	-15

Table III. Raw Data File Name Arrangements (A-Probe).

0.7	B7KP25	B7KP20	B7KP15	B7KP10	B7KP05	B7KP00	B7KN05	B7KN10	B7KN15
0.6	B6KP25	B6KP20	B6KP15	B6KP10	B6KP05	B6KP00	B6KN05	B6KN10	B6KN15
0.5	B5KP25	B5KP20	B5KP15	B5KP10	B5KP05	B5KP00	B5KN05	B5KN10	B5KN15
0.4	B4KP25	B4KP20	B4KP15	B4KP10	B4KP05	B4KP00	B4KN05	B4KN10	B4KN15
0.3	B3KP25	B3KP20	B3KP15	B3KP10	B3KP05	B3KP00	B3KN05	B3KN10	B3KN15
0.2	B2KP25	B2KP20	B2KP15	B2KP10	B2KP05	B2KP00	B2KN05	B2KN10	B2KN15
1 Mach Pitch	25	20	15	10	5	0	-5	-10	-15

TABLE IV. Raw Data File Name Arrangements (B-Probe).

COEFFICIENTS FOR THE CALIBRATION SURFACE STORED IN FILE CALIB : 26 Final

M(order)	N(order)	1	2	3	4	5	6	7	8
1	↓	0.059417	-0.055206	0.093789	-0.568496	0.709473			
2		1.1497211	0.71829	-1.353865	6.986667	-9.502608			
3		-2.106698	-3.402927	-32.213791	14.260991	10.047395			
4		-2.497551	85.379859	35.979987	-44.118652	12.851882			
5		30.158485	-317.029310	435.952540	-332.115046	105.587091			

ERRORS AT EACH POINT

Mach	Pitch Angle	1	2	3	4	5	6	7	8	9
↓	+25°									-15°
0.2		-2.349	0.059	0.039	0.709	-0.310	-1.180	0.678	0.367	-1.439
0.3		1.395	-0.506	-1.129	-0.409	0.676	0.694	0.476	0.049	0.189
0.4		-0.151	-0.115	-0.261	0.563	0.241	-1.955	-1.274	-0.217	-0.365
0.5		-0.129	-0.020	-0.257	0.764	0.100	-0.051	0.018	0.050	0.02
0.6		0.243	-0.322	-0.425	-0.209	-0.525	0.046	0.124	0.015	-1.105
0.7		0.020	-0.179	0.091	0.245	0.025	-0.038	-0.471	0.521	0.365

Table VI(a). Coefficients and Errors for Mach Number (X_{vel}) Approximation.

COEFFICIENTS FOR THE CALIBRATION SURFACE STORED IN FILE CALIB : 26 Final

M(order)	N(order)	1	2	3	4	5	6	7	8
1	↓	-0.774307	1.009177	-0.11061	0.451303				
2		0.2611043	-1.000104	0.000000	0.17340005				
3		-0.0000000	0.0000000	0.0000000	-0.0000000	-0.0000000			
4		0.0000000	0.0000000	0.0000000	0.0000000	0.0000000	0.0000000		
5		-0.5000000	0.0000000	0.0000000	0.0000000	0.0000000	0.0000000	0.0000000	

ERRORS AT EACH POINT

Mach	Pitch Angle	1	2	3	4	5	6	7	8	9
↓	+25°									-15°
0.2		0.144	-1.510	0.219	-0.174	-0.090	1.655	-0.247	-0.449	-0.059
0.3		0.311	0.305	0.019	-0.051	0.490	0.205	0.439	0.311	0.521
0.4		-0.044	0.050	0.016	-0.043	-0.005	-0.008	-0.033	0.022	-0.006
0.5		-0.140	0.015	0.059	0.067	-1.526	0.744	1.136	1.632	-0.370
0.6		-0.210	0.000	-0.000	0.000	-0.000	0.000	0.123	-0.569	-0.570
0.7		-0.047	0.000	-0.022	-0.300	0.150	-0.105	0.327	-0.153	0.500

Table VI(b). Coefficients and Errors for Pitch Angle (ϕ) Approximation.

CALCULATION			MEASUREMENT			ERRORS		
X Vel	Pitch	Yaw	X Vel	Pitch	Yaw	X Vel	Pitch	Yaw
[]	[°]	[°]	[]	[°]	[°]	[%]	[°]	[°]
.1365	14.83	.69	.1347	15.00		-1.3357	.17	-.69
.1358	9.96	.52	.1349	10.00		-.6396	.04	-.52
.1343	5.03	.15	.1346	5.00		.2487	-.03	-.15
.1332	.07	.40	.1345	0.00		1.0161	-.07	-.40
.1766	14.75	.73	.1750	15.00		-.9074	.25	-.73
.1755	9.87	.71	.1758	10.00		.1439	.13	-.71
.1747	5.33	.68	.1750	5.00		.1923	-.33	-.68
.1751	.22	.53	.1751	0.00		.0256	-.22	-.53
.2155	14.04	.13	.2163	15.00		.3642	.96	-.13
.2161	9.09	.64	.2161	10.00		-.0087	.91	-.64
.2178	4.03	.80	.2160	5.00		-.8027	.97	-.80
.2182	- 1.36	1.05	.2162	0.00		-.9259	1.36	-1.05
.2643	15.36	.16	.2626	15.00		-.6210	-.36	-.16
.2635	10.56	.08	.2624	10.00		-.4118	-.56	-.08
.2639	4.02	.19	.2622	5.00		-.6578	.98	-.19
.2643	.54	.91	.2622	0.00		-.8000	-.54	-.91
.2960	15.20	1.01	.2944	15.00		-.5198	-.20	-1.01
.2968	10.64	.38	.2945	10.00		-.8086	-.64	-.38
.2978	5.03	.76	.2945	5.00		-1.1207	-.03	-.76
.2944	.41	1.16	.2948	0.00		.1303	-.41	-1.16
						Averages: -0.3717	+ 0.119	-0.504

Table VII. Errors in Mach Number, Pitch and Yaw Angle for the Application of Calibration Procedure to Calibration Raw Data.

CALCULATED FROM MEASURED DATA			ADJUSTED FREEJET VALUES			ERRORS		
<u>X Vel</u> []	<u>Pitch</u> [°]	<u>Yaw</u> [°]	<u>X Vel</u> []	<u>Pitch</u> [°]	<u>Yaw</u> [°]	<u>X Vel</u> []	<u>Pitch</u> [°]	<u>Yaw</u> [°]
.14206	.04	0.31	.1420	0	0	-0.04	-0.04	-0.31
.14373	4.74	-0.11	.1459	5	0	+1.49	-0.26	+0.11
.14368	4.79	0.1	.1459	5	0	+1.52	+0.21	-0.1
.14315	10.18	0.24	.1450	10	0	+1.28	-0.18	-0.24
.14483	14.82	- 0.3	.1448	15	0	-0.02	+0.18	+0.30
.16787	9.78	0.78	.170	10	0	+1.22	+0.22	-0.78
.17199	8.97	5.46	.170	10	5	-1.17	+1.03	-0.45
.17053	10.20	10.22	.170	10	10	-0.31	-0.2	-0.22
.20382	7.66	- 0.18	.2049	7	0	+0.53	-0.66	+0.18
.21165	10.16	0.2	.211	10	0	-0.31	-0.16	-0.2
.20467	13.21	0.24	.2052	13	0	+0.26	-0.21	-0.24

Table VIII. Errors in Mach Number, Pitch and Yaw Angle for A-B Probe Application Test in Freejet.

Xvel ()	Phi (°)	CpOB ()
.0958	25	.0030
.0962	20	.1470
.0961	15	.2790
.0960	10	.4250
.0962	5	.5680
.0965	0	.6930
.0965	- 5	.7860
.0963	-10	.8470
.0954	-15	.9040
.1348	25	.0460
.1348	20	.1970
.1347	15	.3320
.1349	10	.4760
.1346	5	.6080
.1345	0	.7290
.1353	- 5	.8240
.1343	-10	.8900
.1349	-15	.9190
.1754	25	.0930
.1752	20	.2400
.1750	15	.3810
.1758	10	.5160
.1750	5	.6390
.1751	0	.7480
.1744	- 5	.8510
.1744	-10	.9200
.1742	-15	.9520
.2171	25	.1290
.2165	20	.2750
.2163	15	.4130
.2161	10	.5480
.2160	5	.6720
.2162	0	.7770
.2161	- 5	.8690
.2152	-10	.9370
.2156	-15	.9620
.2636	25	.1740
.2624	20	.3230
.2626	15	.4590
.2624	10	.6010
.2622	5	.7150
.2622	0	.8150
.2628	- 5	.8860
.2630	-10	.9340
.2627	-15	.9690
.2949	25	.2140
.2944	20	.3590
.2944	15	.5010
.2945	10	.6330
.2945	5	.7450
.2948	0	.8330
.2948	- 5	.9020
.2950	-10	.9490
.2952	-15	.9830

Table IX. CpOB for All Calibration Configurations of Mach Number and Pitch Angle

Online calibration (File: 001911)

Point #	Inner Comp. Inner A pr. Inner B pr.	YAW Comp. YAW A pr. YAW B pr.	P1 DCB	P2 DCB	P3 DCB
1	.000997 .000997 .000997	.003099 .003099 .003099	.000369 .000369 -.000369	.000052 .000369 1525.00000	.000017 .000369 .000017
2	.000999 .000999 .000999	.003097 .003099 .003097	.000372 -.000372 -.000372	.000050 .000372 1525.00000	.000017 .000372 .000017
3	.000999 .000999 .000999	.003100 .003103 .003100	.000369 .000369 .000369	.000045 -.000369 1525.00000	.000017 .000369 .000017
4	.000999 .000999 .000999	.003100 .003100 .003100	.000374 .000374 .000374	.000054 .000374 1525.00000	.000017 .000374 .000017

Online calibration (File: 001911)

Point #	Inner Comp. Inner A pr. Inner B pr.	YAW Comp. YAW A pr. YAW B pr.	P1 DCB	P2 DCB	P3 DCB
1	.000999 .000999 .000999	.003063 .003091 .003098	.000372 .000372 .000372	.000050 -.000372 1525.00000	.000017 .000372 .000017
2	.000999 .000999 .000999	.003115 .003091 .003099	.000372 -.000372 -.000372	.000051 .000372 1525.00000	.000017 .000372 .000017
3	.000999 .000999 .000999	.003093 .003094 .003091	.000372 .000372 .000372	.000052 -.000372 1525.00000	.000017 .000372 .000017
4	.000999 .000999 .000999	.003100 .003097 .003099	.000372 .000372 -.000372	.000052 .000372 1525.00000	.000017 .000372 .000017

	A probe Slope	Intercept %	B probe Slope	Intercept %
1st calibration	-.000048	.000370 %	-.000049	.000370 %
2nd calibration	-.000253	.000375 %	-.000048	.000370 %

Table X(a). On-line Calibration Data for Actual Compressor Test (run #119).

Point #	Inner Comp. Lower A pr.	YOH Comp. YOH A pr.	31 900	920 900	
	Inner B pr.	YOH B pr.	900	900	
1	.000901 .000907 .000917	.003947 -.002906 -.002927	.000372 -.001231 -.002172	.000006 .000003 1527.00000	.000007 .000003 -.000001
Averaged values	paced output	: A probe	: B probe	: C probe	: D probe
2	.000902 .000912 .000911	.003960 -.002904 -.001926	.000372 .001989 -.000020	.000003 .000000 1527.00000	.000003 .000000 -.000001
Averaged values	paced output	: A probe	: B probe	: C probe	: D probe
3	.000901 .000903 .000912	.003950 -.002907 0.000010	.000374 .001989 .001223	.000003 .000003 1527.00000	.000004 .000003 .000001
Averaged values	paced output	: A probe	: B probe	: C probe	: D probe
4	.000901 .000902 .000913	.003950 .001921 .001992	.000369 .001921 .001961	.000003 .000001 1527.00000	.000004 .000001 .000001
Averaged values	paced output	: A probe	: B probe	: C probe	: D probe
5	.000900 .000902 .000905	.003990 .002970 .002979	.000374 .002950 .002059	.000003 .000003 1527.00000	.000004 .000002 .000002
Averaged values	paced output	: A probe	: B probe	: C probe	: D probe
6	.000900 .000901 .000911	.003927 .004066 .004509	.000374 .003570 .001906	.000004 .000002 1527.00000	.000004 .000002 .000002
Averaged values	paced output	: A probe	: B probe	: C probe	: D probe
7	.000900 .000901 .000909	.003994 .004099 .004533	.000373 .002957 .001294	.000004 1.000000 1527.00000	.000004 .000002 .000001
Averaged values	paced output	: A probe	: B probe	: C probe	: D probe
8	.000913 .000902 .000912	.003927 .003977 .002924	.000374 .001969 -.000509	.000003 .000001 1527.00000	.000004 .000001 -.000001
Averaged values	paced output	: A probe	: B probe	: C probe	: D probe
9	.000900 .000901 .000910	.003974 .002937 .001924	.000375 -.002906 -.001902	.000003 1.000000 1527.00000	.000005 .000002 -.000001
Averaged values	paced output	: A probe	: B probe	: C probe	: D probe

Table X(b). Run Steady State Data From A-B Probe Measurement (run #119).

DATA ARRANGEMENT IN DATA FILE FOR RAW DATA FROM KULITE SURVEY
DATA(2,256)

CALIBRATION #	POINT #	1st YAW A	1st YAW B	2nd YAW A	2nd YAW B	---	9th YAW A	9th YAW B	# STEADY STATE	YAW			
DATA(1, 1)	1st	DATA(2, 1)	DATA(3, 1)	DATA(4, 1)	DATA(5, 1)	---	DATA(12, 1)	DATA(19, 1)	DATA(20, 1)	1st			
DATA(1, 2)		DATA(2, 2)	DATA(3, 2)	DATA(4, 2)	DATA(5, 2)	---	DATA(12, 2)	DATA(19, 2)	DATA(20, 2)				
DATA(1, 3)		DATA(2, 3)	DATA(3, 3)	DATA(4, 3)	DATA(5, 3)	---	DATA(12, 3)	DATA(19, 3)	DATA(20, 3)				
DATA(1, 19)		DATA(2, 19)	DATA(3, 19)	DATA(4, 19)	DATA(5, 19)	---	DATA(12, 19)	DATA(19, 19)	DATA(20, 19)				
DATA(1, 21)		2	DATA(2, 21)	DATA(3, 21)	DATA(4, 21)	DATA(5, 21)	---	DATA(12, 21)	DATA(19, 21)		DATA(20, 21)	2nd	
DATA(1, 22)			DATA(2, 22)	DATA(3, 22)	DATA(4, 22)	DATA(5, 22)	---	DATA(12, 22)	DATA(19, 22)		DATA(20, 22)		
DATA(1, 39)		3rd	<i>J = 1, 2, 4, 6, 11, 14</i>									3rd	
DATA(1, 41)			<i>Data for online calibration</i>										
DATA(1, 42)			DATA(1, J)	= TARE2	=	ACGN (4, 1, 10)							DATA(20, 41)
			DATA(1, J+1)	= PCHL2	=	ACGN (4, 2, 10)							DATA(20, 42)
			DATA(1, J+2)	= P1	=	ACGN (4, 6, 10)							
			DATA(1, J+3)	= P23	=	ACGN (4, 7, 10)							
			DATA(1, J+4)	= P4	=	ACGN (4, 8, 10)							DATA(20, 60)
DATA(1, 58)			DATA(1, J+5)	= PPM	=	SCANR (8, 12, 1)							
			DATA(1, J+6)	= PRGRD	=	SCANR (8, 25, 1)							DATA(20, 51)
DATA(1, 51)			DATA(1, J+7)	= XIMC	=	SCANR (8, 32, 1)							DATA(20, 52)
DATA(1, 52)			DATA(1, J+8)	= YAWC	=	SCANR (8, 33, 1)							
			DATA(1, J+9)	= XIMB	=	SCANR (8, 34, 1)							
			DATA(1, J+10)	= YAWB	=	SCANR (8, 35, 1)							DATA(20, 80)
DATA(1, 79)	DATA(1, J+11)		= XIMR	=	SCANR (8, 36, 1)								
	DATA(1, J+12)		= YAWR	=	SCANR (8, 37, 1)								
	DATA(1, J+13)		= PRGR	=	SCANR (8, 39, 1)								
DATA(1, 91)	DATA(1, J+14)		= E	=	SCANR (15, 18, 1)					DATA(20, 91)			
DATA(1, 92)	DATA(1, J+15)	= DE	=	SCANR (15, 19, 1)					DATA(20, 92)				
	DATA(1, J+16)	= DCA	=	SCANR (15, 52, 1)									
	DATA(1, J+17)	= DCB	=	SCANR (15, 53, 1)									
DATA(1, 99)									DATA(20, 100)				
DATA(1, 101)	2nd	<i>I = 1, 2, 4, 16</i>									2nd		
DATA(1, 102)		<i>Data for steady state</i>											
		DATA(20, I)	=	ACGN (4, 1, 10)	TARE2					DATA(20, 101)			
		DATA(20, I+1)	=	ACGN (4, 2, 10)	PCHL2					DATA(20, 102)			
		DATA(20, I+2)	=	ACGN (4, 6, 10)	P1								
		DATA(20, I+3)	=	ACGN (4, 7, 10)	P23					DATA(20, 121)			
		DATA(20, I+4)	=	ACGN (4, 8, 10)	P4					DATA(20, 122)			
		DATA(20, I+5)	=	SCANR (8, 12, 1)	PPM								
		DATA(20, I+6)	=	SCANR (8, 25, 1)	PRGRD								
		DATA(20, I+7)	=	SCANR (8, 32, 1)	XIMC								
		DATA(20, I+8)	=	SCANR (8, 33, 1)	YAWC					DATA(20, 140)			
		DATA(20, I+9)	=	SCANR (8, 34, 1)	XIMB								
		DATA(20, I+10)	=	SCANR (8, 35, 1)	YAWB					DATA(20, 141)			
		DATA(20, I+11)	=	SCANR (8, 36, 1)	XIMR					DATA(20, 142)			
		DATA(20, I+12)	=	SCANR (8, 37, 1)	YAWR								
		DATA(20, I+13)	=	SCANR (8, 39, 1)	PRGR								
		DATA(20, I+14)	=	SCANR (15, 18, 1)	E					DATA(20, 160)			
		DATA(20, I+15)	=	SCANR (15, 19, 1)	DE					DATA(20, 161)			
		DATA(20, I+16)	=	SCANR (15, 52, 1)	DCA					DATA(20, 162)			
	DATA(20, I+17)	=	SCANR (15, 53, 1)	DCB					DATA(20, 163)				
	DATA(20, I+18)	=	AURSA										
	DATA(20, I+19)	=	AURRB										
DATA(1, 150)	#Slope A 1st												
DATA(1, 161)	#Inter. A 1st												
DATA(1, 170)	#Slope B 1st												
DATA(1, 171)	#Inter. B 1st												
DATA(1, 180)	#Slope A 2nd												
DATA(1, 191)	#Inter. A 2nd												
DATA(1, 190)	#Slope B 2nd												
DATA(1, 191)	#Inter. B 2nd												

		DATA(2,256)	DATA(3,256)	DATA(4,256)	DATA(5,256)	---	DATA(12,256)	DATA(19,256)					

Table XI. Arrangement of Data Within Raw Data File.
61

RAW DATA FILE : AB1901:: 27

FLOW AVARAGED VALUES AS ESTABLISHED WITH THE COMBINATION PROBE

Ptotal(INCH H2O) Pstatic(INCH H2O) Xvel Mach Phi(deg) Yaw(deg)
438.852110 402.299380 .15693 .35443 4.55 30.76

EQUATION FOR A-PROBE PRESSURE :

PA = 400.532230 + 9966.041000 * VOLTAGE(raw)*0.01 + PREF(INCH H2O)

CP0A = 1.00408 CP0B = .6394757

EQUATION FOR B-PROBE PRESSURE :

PB = 405.349850 + 9709.025400 * VOLTAGE(raw)*0.01 + PREF(INCH H2O)

PAA(°) PAB(°) YAWA(°) YAWB(°)

1 388.564 384.562 -40.060 -39.850
2 415.562 405.356 -20.040 -19.750
3 432.724 417.524 -.37000 0.00000
4 438.413 424.489 14.7100 15.0200
5 438.205 425.738 29.7000 29.7900
6 436.311 424.055 44.6600 45.0900
7 429.005 417.040 64.9900 65.3300
8 412.283 400.314 84.7900 85.2400
9 376.753 370.378 109.570 110.280

A-PROBE APPROXIMATION RESULTS : YAW = -32.03 30.97 93.97
PRESSURE (INCH H2O) = 401.494630 438.987430 401.494690
CPAMAX = 1.0036

B-PROBE APPROXIMATION RESULTS : YAW0 = 31.1 PRESSURE (INCH H2O) =426.03

AVERAGE VALUE RESULTS FROM THE A-B SYSTEM:

BETA GAMMA Xvel Pitch Yaw XU XAX BETA2
.08541 .34569 .15693 4.00 31.13 .24251 .13400 50.33

A-PROBE APPROXIMATION RESULTS : YAW = -33.87 29.13 92.13
PRESSURE (INCH H2O) = 401.035520 439.204830 401.035580
CPAMAX = 1.0093

YAWA(I) PA(I) PAC(I) DPA YAWB(I) PB(I) PBC(I) DPE
1 -40.060 390.745 390.620 .12415 -39.850 386.023 386.211 -.18740
2 -20.040 418.046 418.693 -.64673 -19.750 407.238 406.601 .63635
3 -.37000 434.472 433.312 1.16040 0.00000 419.654 420.214 -.56012
4 14.7100 438.073 438.307 -.23431 15.0200 425.849 426.014 -.16504
5 29.7000 438.365 439.171 -.80560 29.7900 427.988 427.737 .25152
6 44.6600 436.436 436.487 -.05164 45.0900 425.091 425.287 -.19550
7 64.9900 428.007 427.055 .95190 65.3300 416.069 415.419 .64966
8 84.7900 409.352 409.953 -.60059 85.2400 397.940 398.495 -.55493
9 109.570 372.605 372.503 .10175 110.280 367.713 367.588 .12476

B-PROBE APPROXIMATION RESULTS : YAW0 = 28.8 PRESSURE (INCH H2O) =427.75

PSTATIC (DERIVED FROM PAMAX AND XVEL) = 402.086

POS# Beta Gamma Xvel Pitch Yaw BETA2
1 .08691 .30020 .15784 2.16 28.77 50.31

Table XII. Explicit Output of Reduced Data (run #119).

Raw Data From File AB1901:27.

POS#	Beta	Gamma	Xvel	Pitch	Yaw	ETA
1	.08691	.30020	.15784	.16	.77	.31
2	.08625	.29869	.15719	.07	.85	.47
3	.08659	.29771	.15751	.04	.88	.39
4	.08693	.29870	.15785	.10	.88	.52
5	.08626	.29383	.15714	1.86	.88	.44
6	.08556	.29333	.15646	1.81	.89	.38
7	.08761	.29336	.15845	1.89	.77	.27
8	.08695	.29314	.15780	1.86	.77	.46
9	.08699	.30001	.15792	1.16	.77	.42
10	.08651	.29053	.15735	1.72	.78	.51
11	.08616	.30175	.15714	.20	.77	.75
12	.08771	.30535	.15867	.41	.77	.99
13	.08736	.31543	.15844	.83	.77	.38
14	.08758	.31300	.15863	.74	.77	.44
15	.08843	.31647	.15949	.91	.77	.10
16	.08708	.32276	.15832	.33	.77	.47
17	.08815	.33026	.15937	.48	.77	.12
18	.08751	.33647	.15883	.71	.77	.25
19	.08845	.34354	.15981	4.03	.77	.07
20	.08694	.35582	.15855	4.57	.77	.37
21	.08777	.35549	.15931	4.49	.88	.11
22	.08727	.35591	.15888	4.61	.88	.32
23	.08724	.35627	.15899	4.76	.88	.32
24	.08730	.35650	.15898	4.85	.88	.32
25	.08809	.35980	.15967	4.67	.88	.03
26	.08817	.35931	.15973	4.65	.77	.09
27	.08765	.36770	.15935	4.97	.88	.03
28	.08754	.37437	.15933	5.22	.88	.13
29	.08721	.35432	.15876	4.42	.88	.16
30	.08759	.36250	.15923	4.76	.99	.02
31	.08590	.34610	.15741	4.04	.88	.41
32	.08591	.33789	.15732	4.71	.99	.38
33	.08682	.34274	.15825	4.94	.88	.30
34	.08629	.33269	.15762	4.51	.88	.40
35	.08633	.33968	.15774	4.80	.88	.44
36	.08652	.33720	.15789	4.70	.99	.31
37	.08466	.32843	.15600	4.27	.88	.01
38	.08430	.32945	.15566	4.29	.88	.94
39	.08466	.31729	.15586	4.80	.88	.85
40	.08445	.31319	.15561	4.62	.99	.85
41	.08548	.31905	.15668	4.91	.88	.66
42	.08583	.32284	.15706	4.08	.88	.67
43	.08569	.31942	.15688	4.93	.88	.88
44	.08616	.31527	.15729	4.78	.88	.53
45	.08673	.32951	.15801	4.39	.99	.28
46	.08768	.32712	.15888	4.63	.88	.06
47	.08778	.32402	.15894	4.21	.88	.12
48	.08757	.32691	.15878	4.32	.99	.07
49	.08892	.31918	.15998	4.04	.88	.82
50	.08780	.32379	.15897	3.20	.88	.13
51	.08746	.32749	.15868	3.34	.88	.22
52	.08814	.31063	.15914	3.65	.88	.04

Table XIII. Reduced Data For the First Blade Passage of Run #119.

Range of Xvel	Range of Pitch	Range of Yaw	E_x [%]	E_ϕ [°]	E_α [°]
$0.134 \leq X \leq 0.216$	$0 \leq \phi \leq 10$	$-10 \leq \alpha \leq 10$	-4.6	0.78	-0.93
$0.134 \leq X \leq 0.216$	$5 \leq \phi \leq 15$	$-10 \leq \alpha \leq 10$	-4.7	0.96	-0.77
$0.175 \leq X \leq 0.263$	$0 \leq \phi \leq 10$	$-10 \leq \alpha \leq 10$	6.0	0.50	-0.65
$0.175 \leq X \leq 0.263$	$5 \leq \phi \leq 15$	$-10 \leq \alpha \leq 10$	-5.0	0.66	-0.57

Table XIV. Errors in Mach Number, Pitch and Yaw Angle for Varying Velocity Vectors.

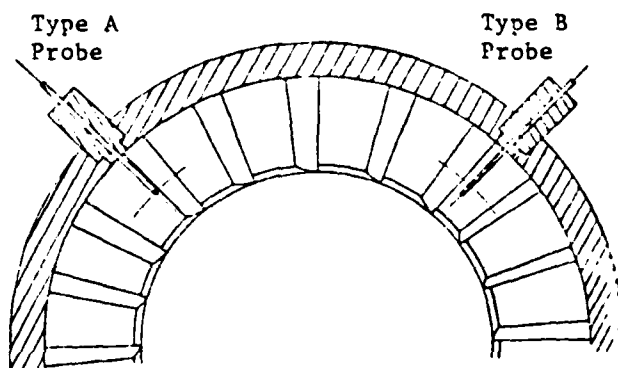
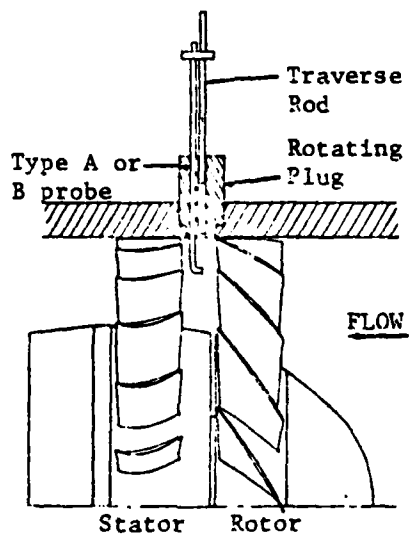

Figure 1. Probe Arrangement in Transonic Compressor

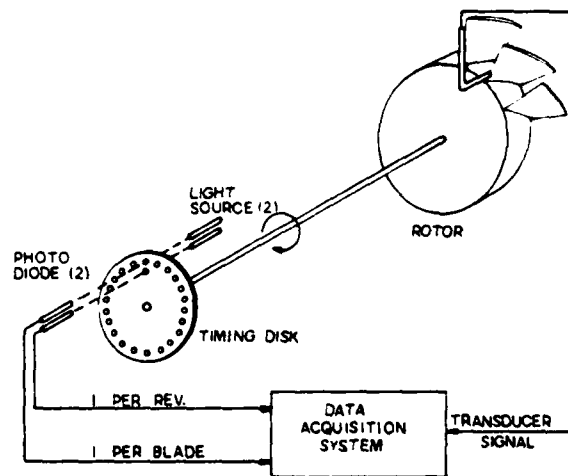

Figure 2. Controlled (Paced) Sampling Technique

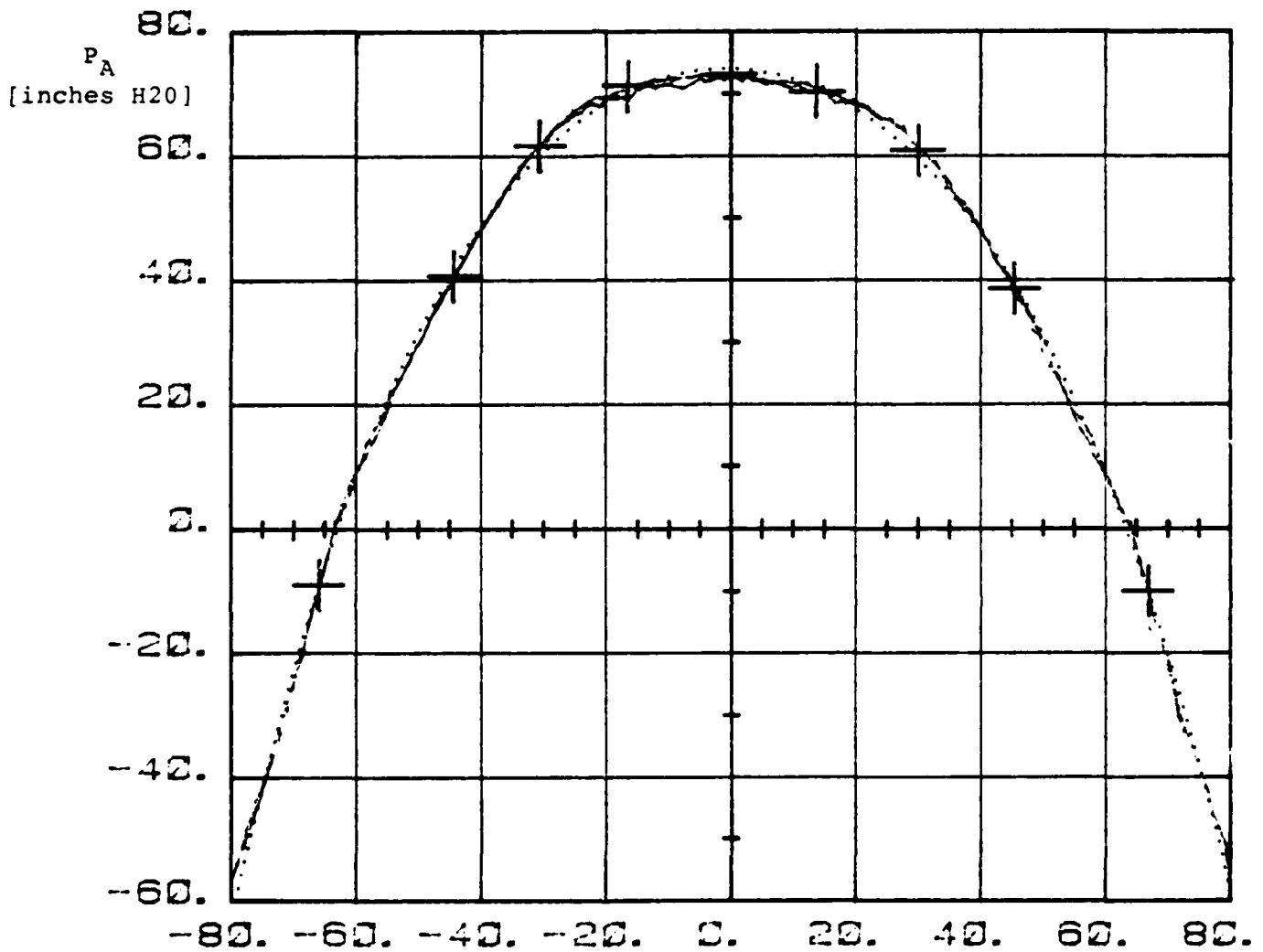

Figure 3a. A-Probe Pressure (Gauge) vs. Yaw Angle YAW ANGLE [Degrees]
 Solid line - Calibration Data
 Dotted line - Data Approximated from Specific Data Points
 (4th Order Polynomials) Shown as crosses
 (Datafile: A5KP10)

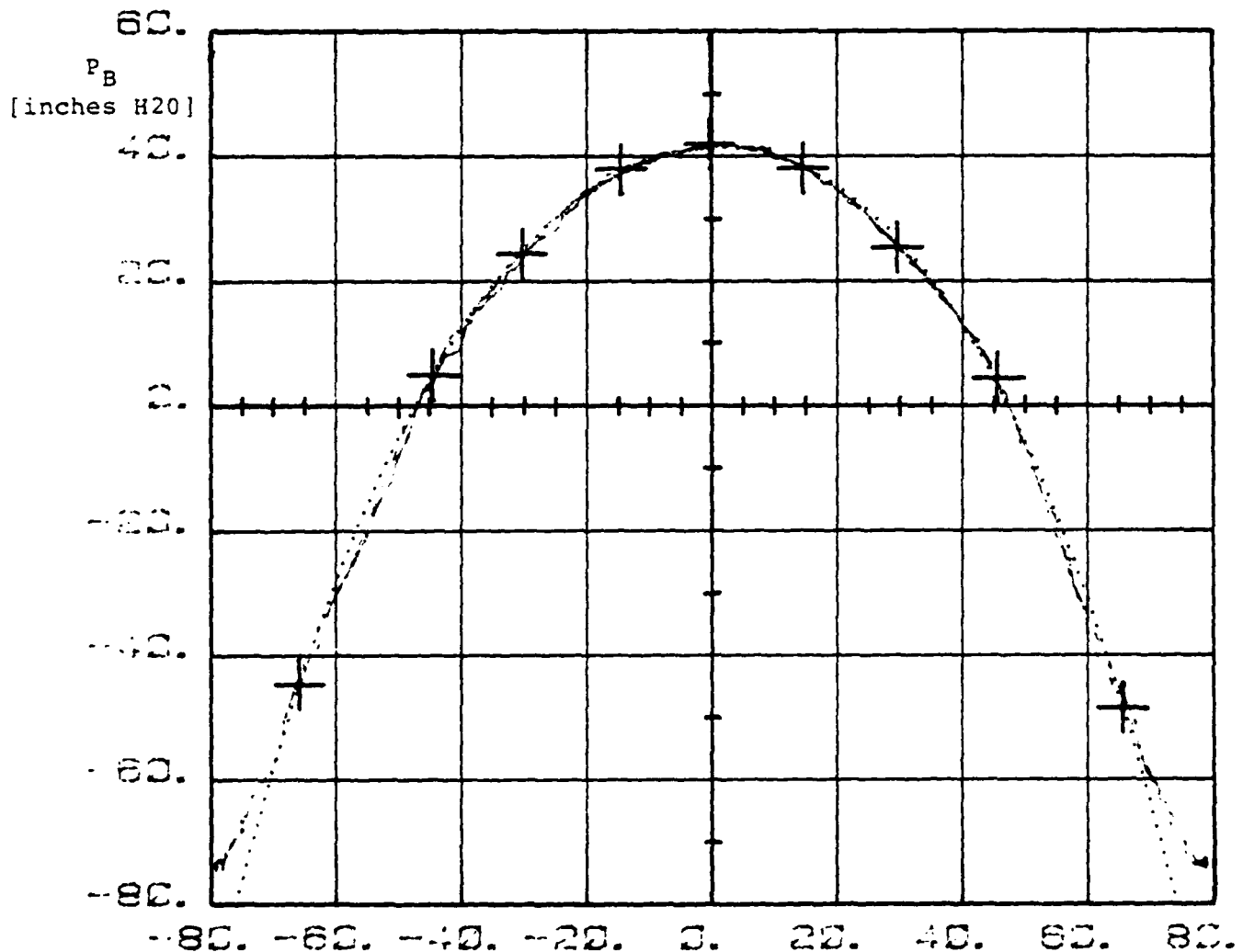

Figure 3b. B-Probe Pressure (Gauge) vs. Yaw Angle YAW ANGLE [Degrees]
 Solid line - Calibration Data
 Dotted line - Data Approximated from Specific Data Points
 (4th Order Polynomials) Shown as crosses
 (Datafile: B5KP10)

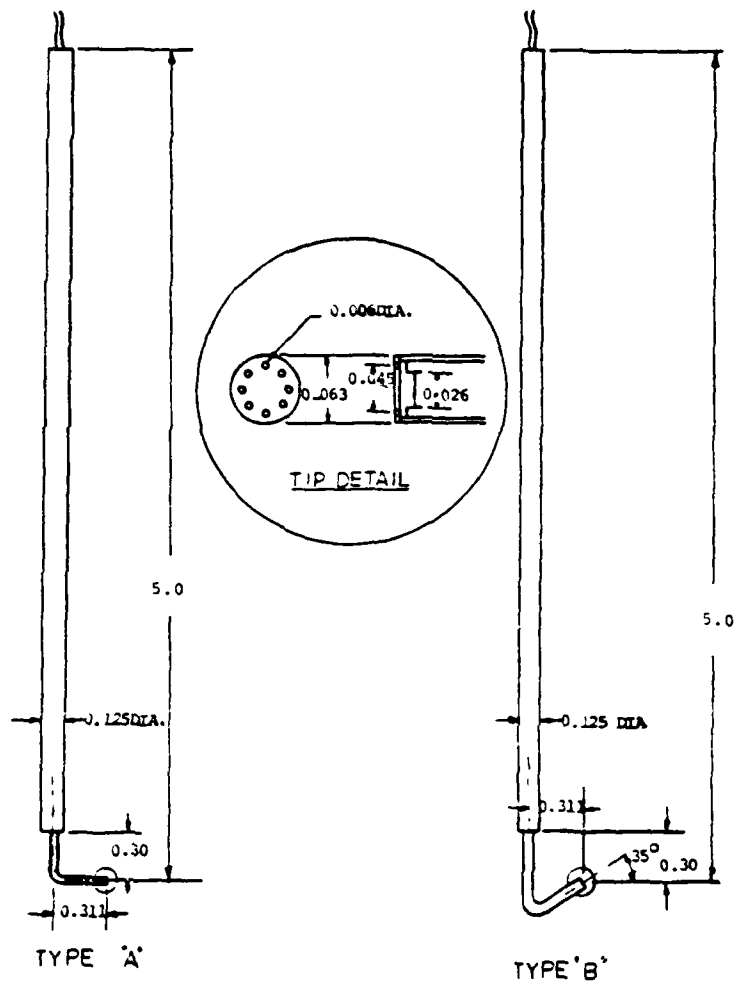

Figure 4. High Response Transducer Probes

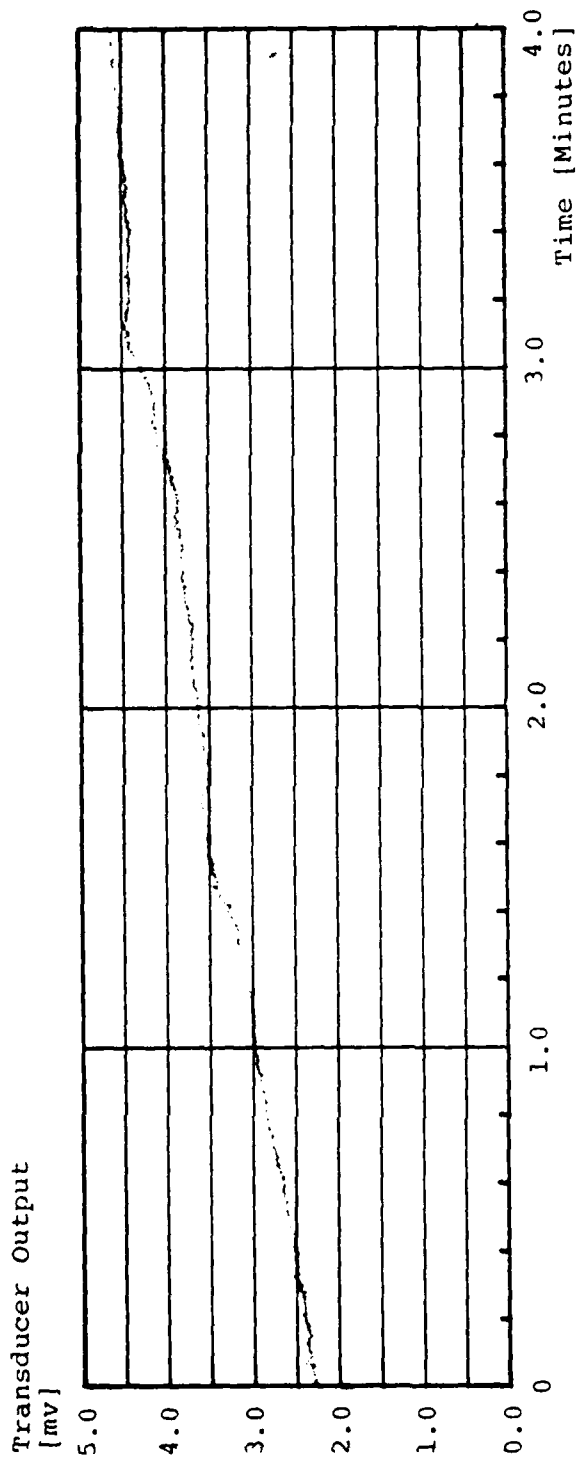

Figure 5. Temperature Sensitivity of a Kulite-Transducer
 Calibrated to: 1mv Equivalent to 1 Inch of Water (Gauge)
 4 Minutes Equivalent to 1000 Single Samples

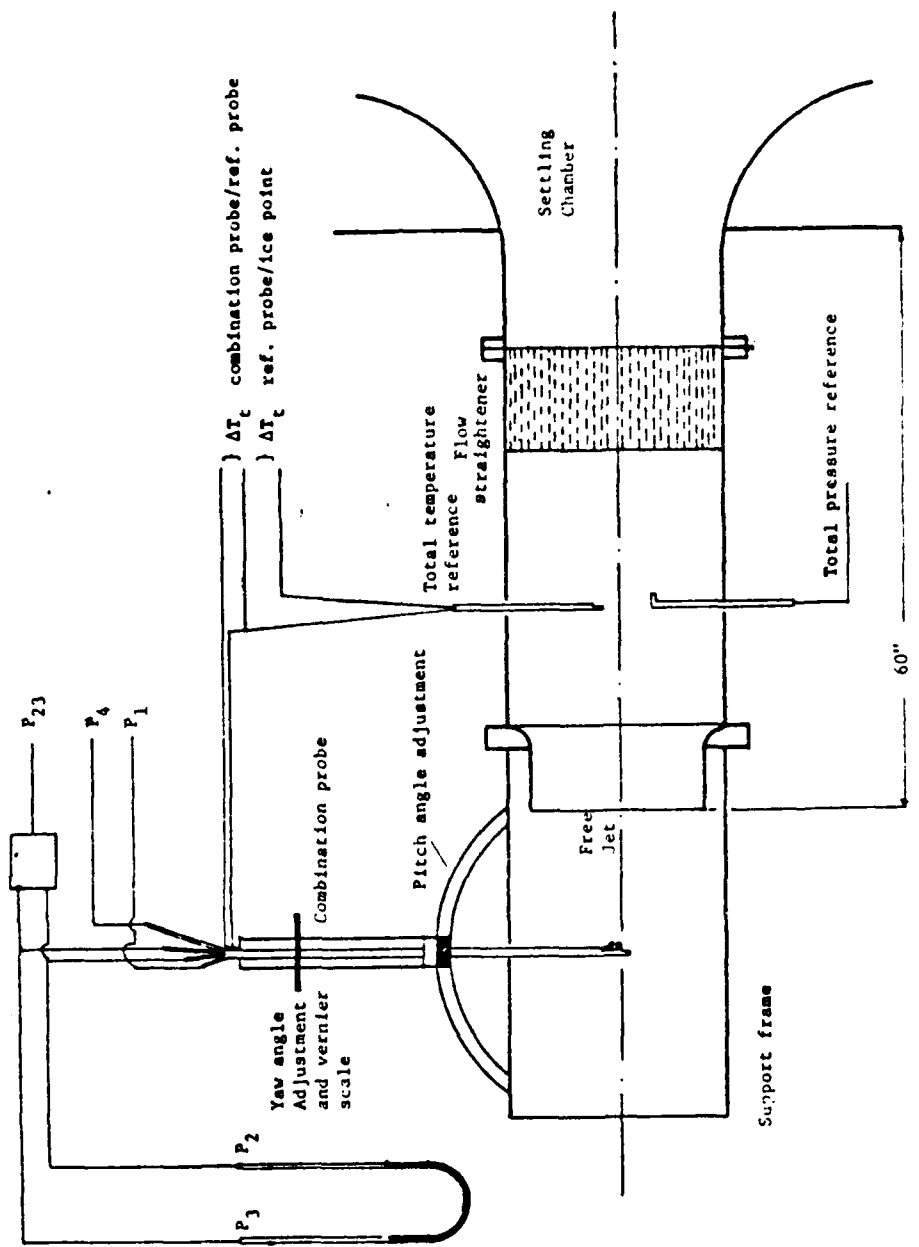
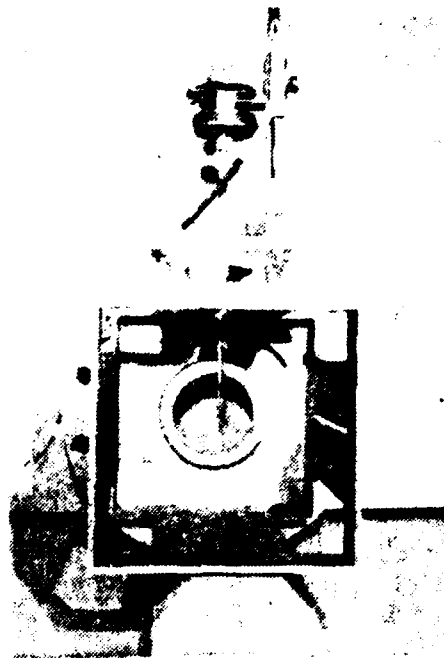
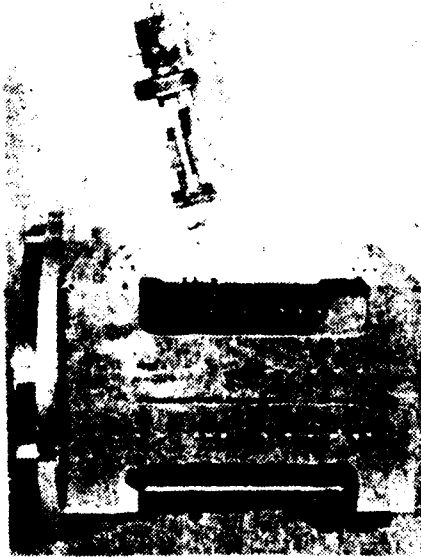

Figure 6a. Calibration Facility Geometry (not to scale)



(a) End View



(b) Side View

Figure 6b. Free-Jet Calibration Apparatus

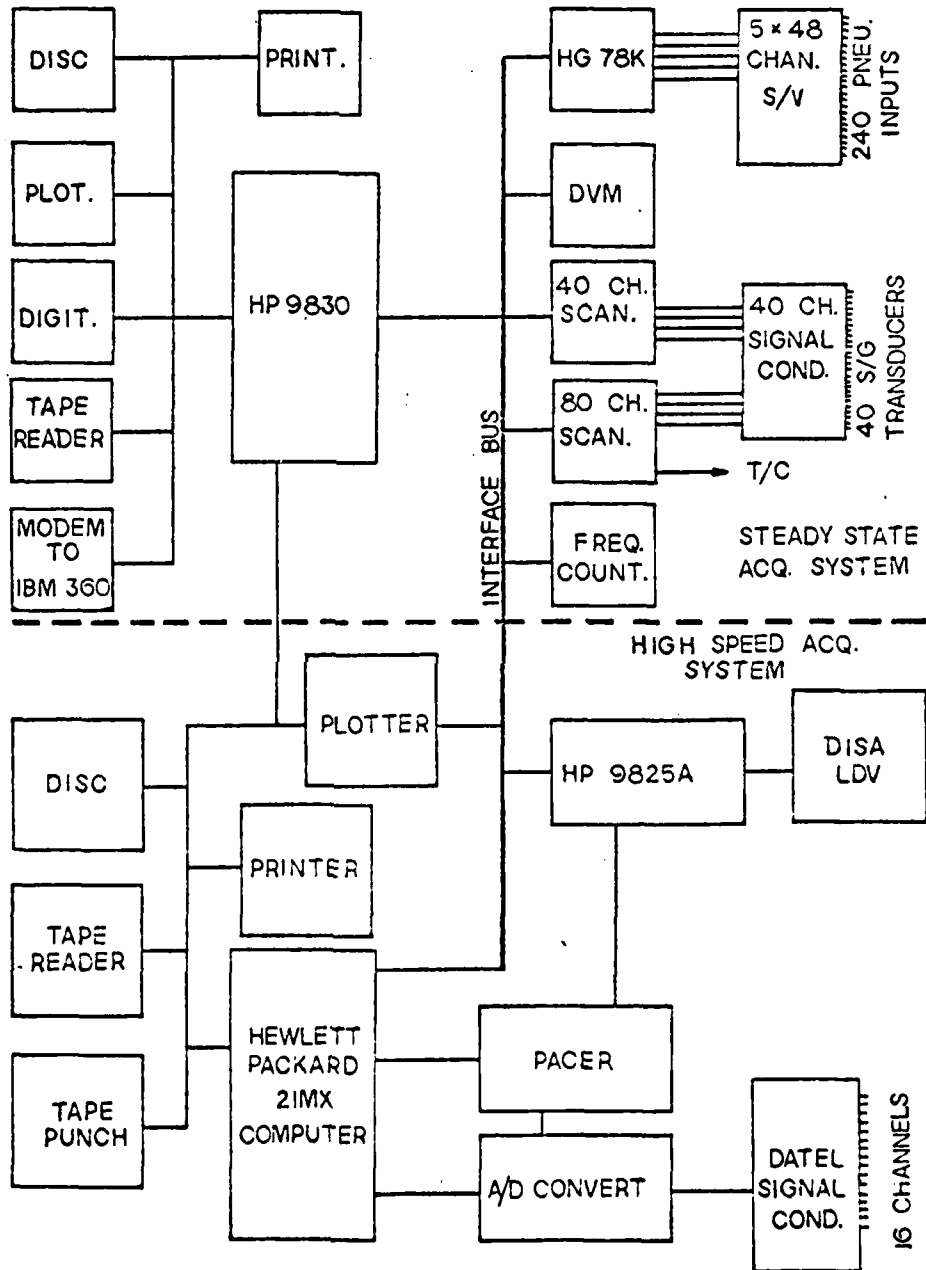

Figure 6c. Data Acquisition System

P_A
[inches H2O Gauge]

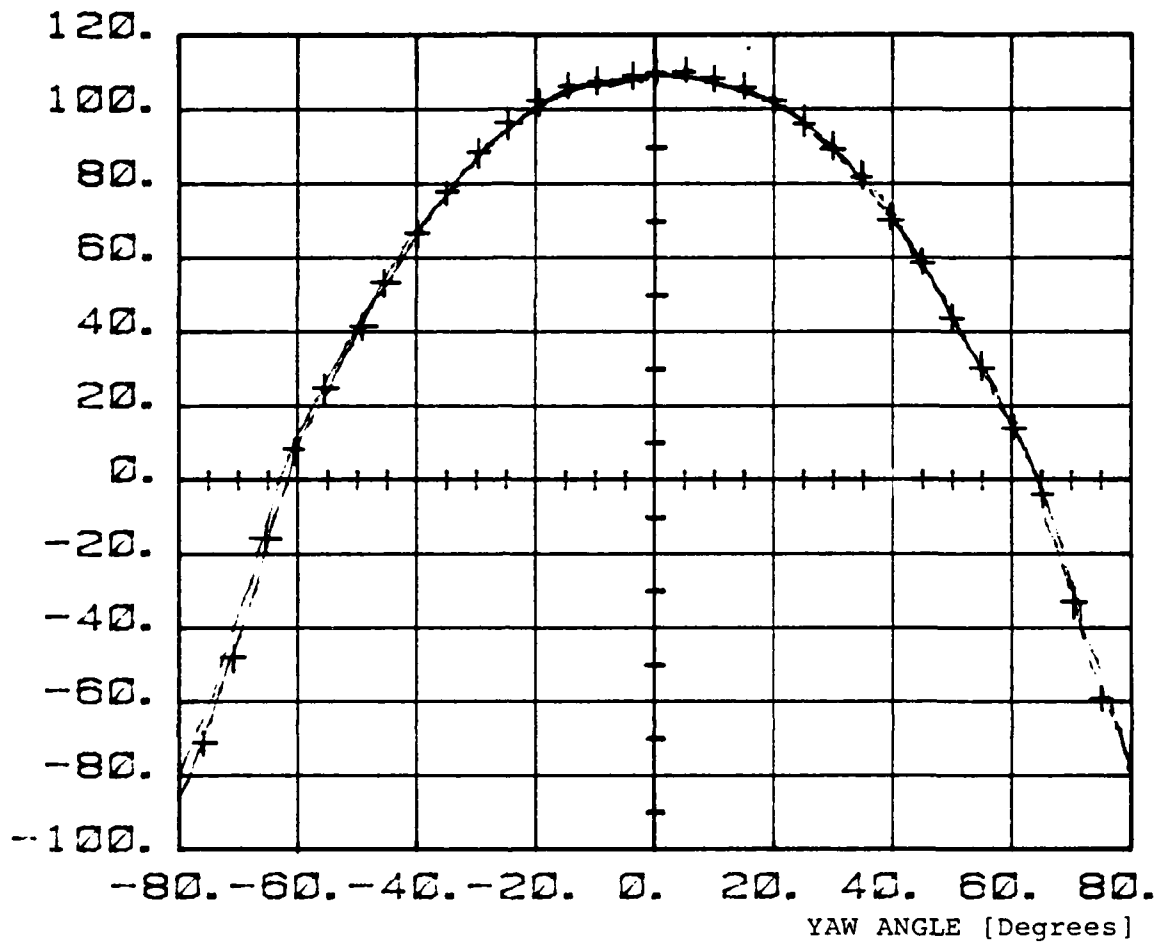

Figure 7. Pressure Readings vs. Yaw Angle. Data Acquired Using Two Different Programs:
Solid lines - Program KALIB (Continuous Acquisition)
Crosses - Program &YAW (Discrete Readings)

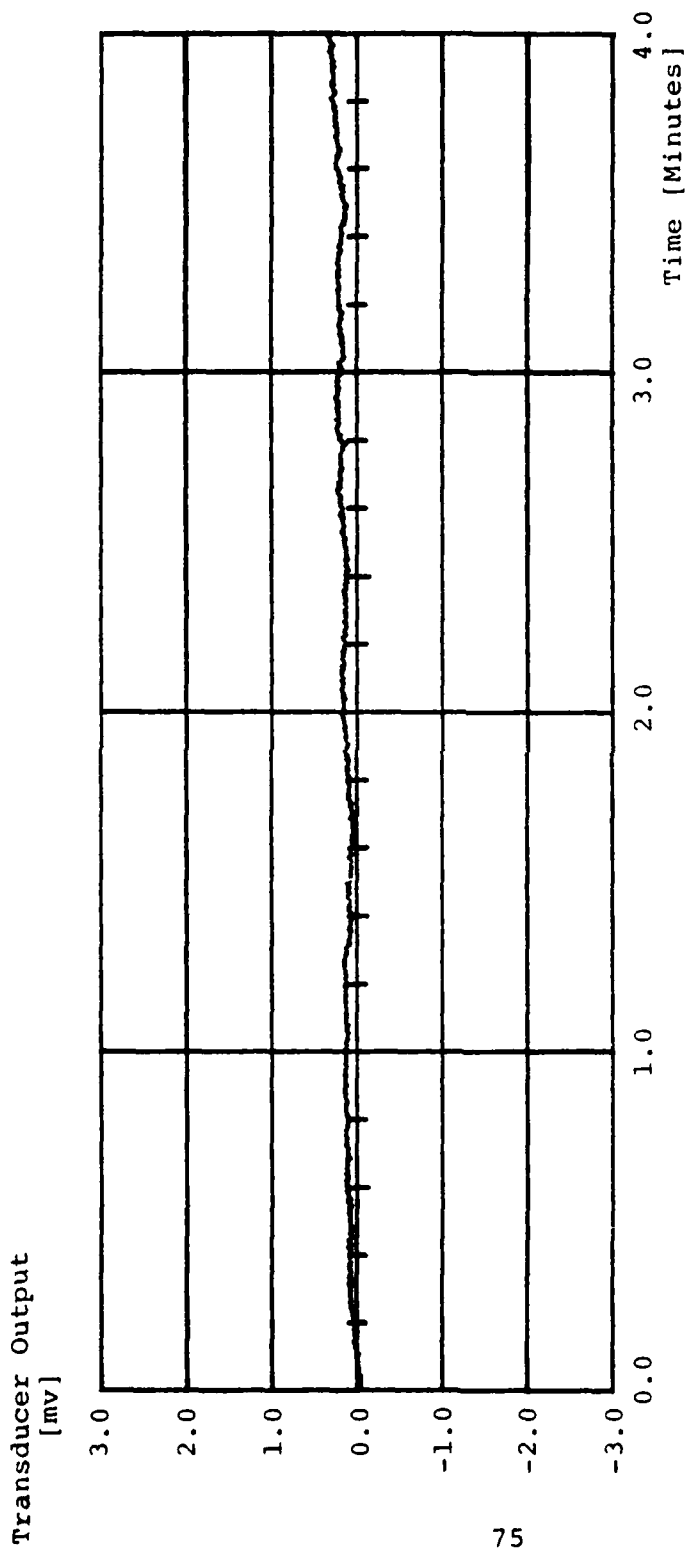

Figure 8. Kulite Transducer Output Depending on Time, No Change in Environment. Calibrated to: 1mv Equivalent to 1 inch of Water.

P_A
[inches H₂O Gauge]

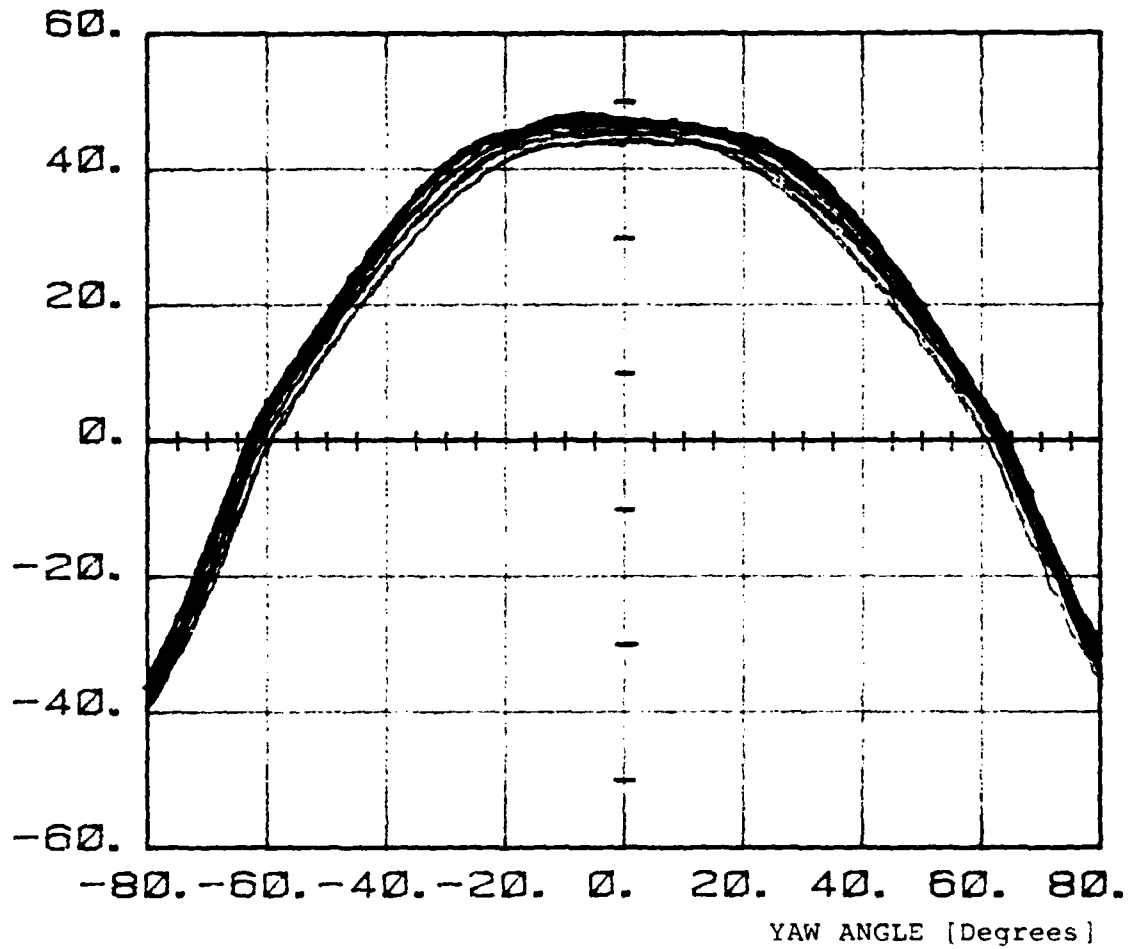

Figure 9. Type A-Probe Calibration Data at Mach = 0.4. Pitch Angles in the Range from -15° to +25°

P_A
[inches H2O Gauge]

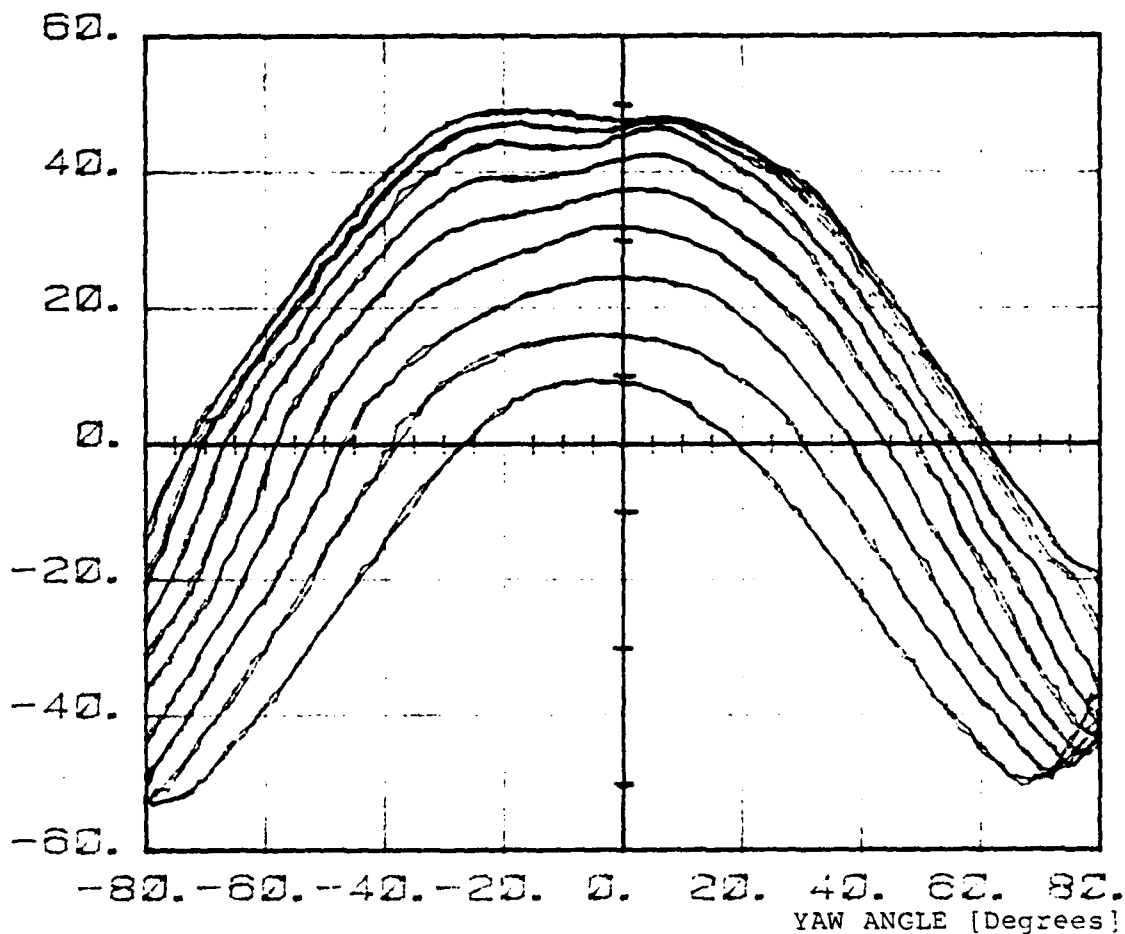

Figure 10. Type B-Probe Calibration Data at Mach = 0.4. Pitch angles in the Range from -15° (Top) to +25° in 5° Increments. Some Holes in probe tip are contaminated by dirt.



Figure 11a. Probe Tip with Dirt in Some Holes



Figure 11b. Probe Tip with Dirt in Some Holes

P_A
[inches H20 Gauge]

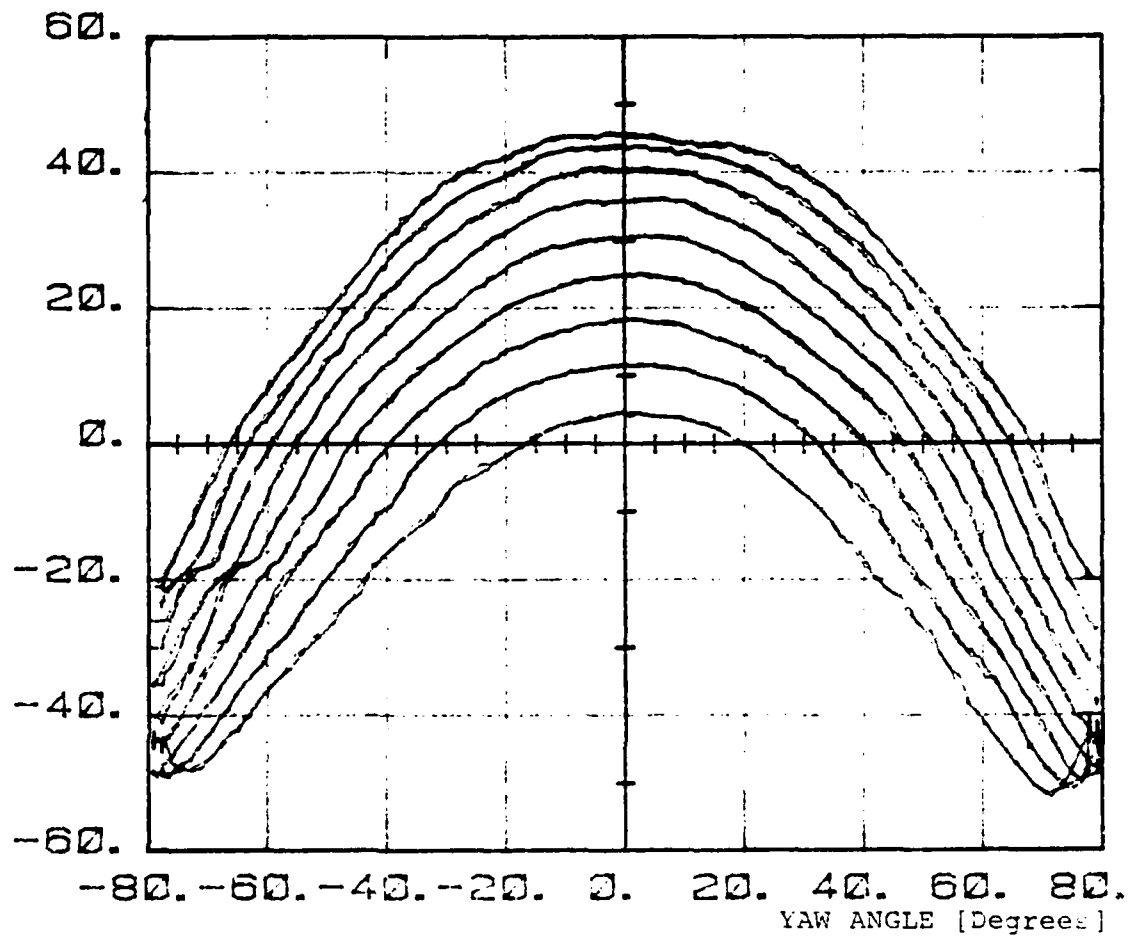

Figure 12. Type B-Probe Calibration Data at Mach = 0.4. Pitch angles in the Range from -15° (Top) to $+25^\circ$ in 5° Increments. Clean Probe Tip.

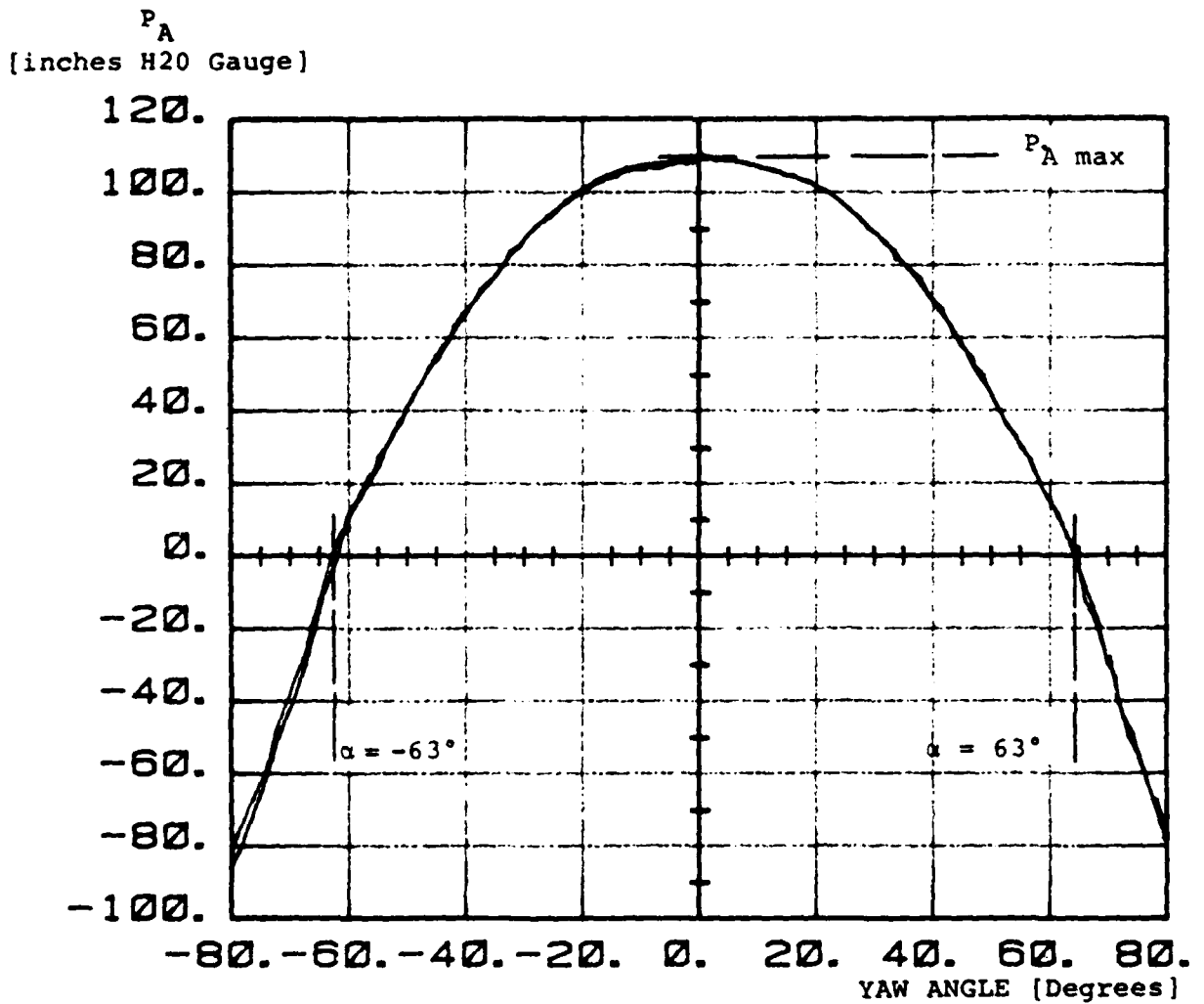

Figure 13. Type A-Probe Output Demonstrating Characteristic Values.
(Mach = 0.6, Pitch angle = 25°)

P_A
[inches H₂O Gauge]

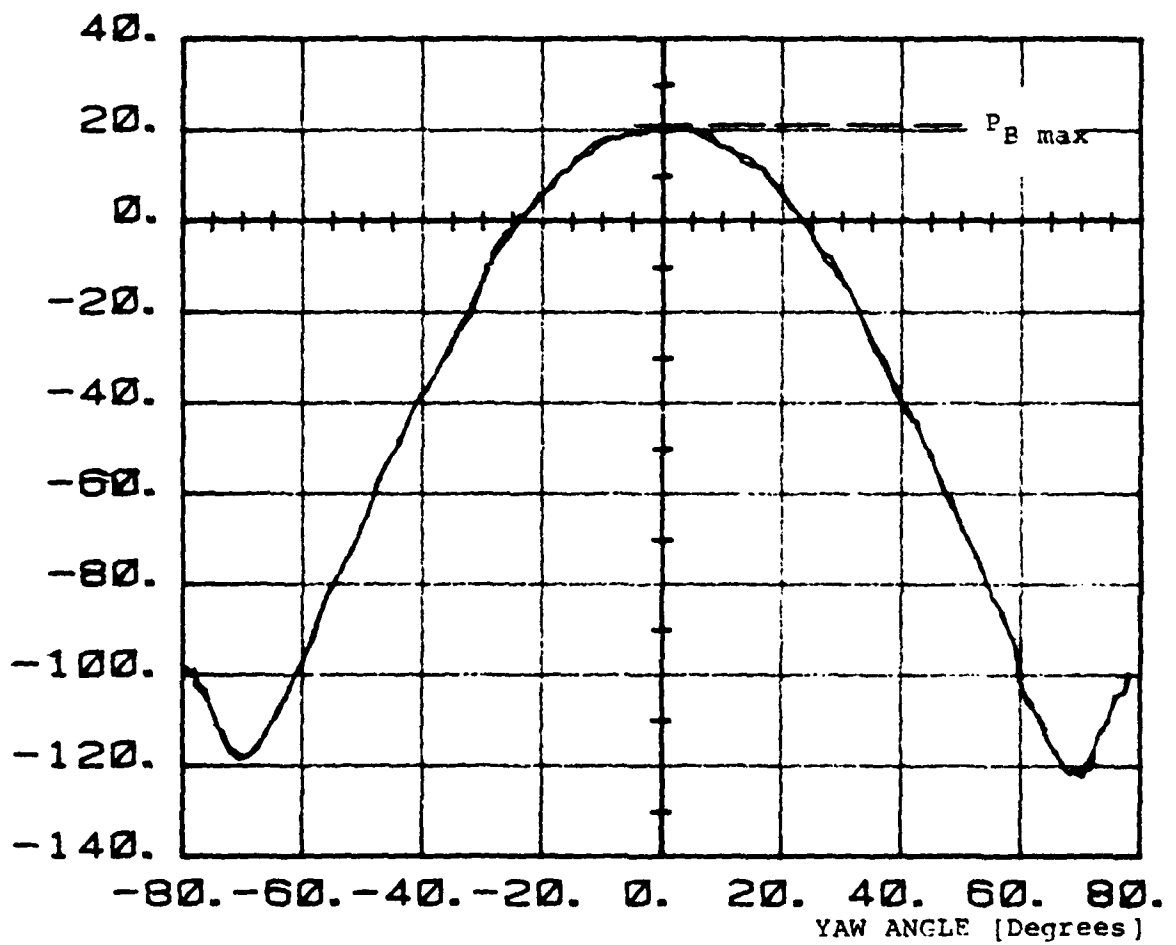

Figure 14. Type B-Probe Calibration Data
(Mach = 0.6, Pitch angle = 25°)

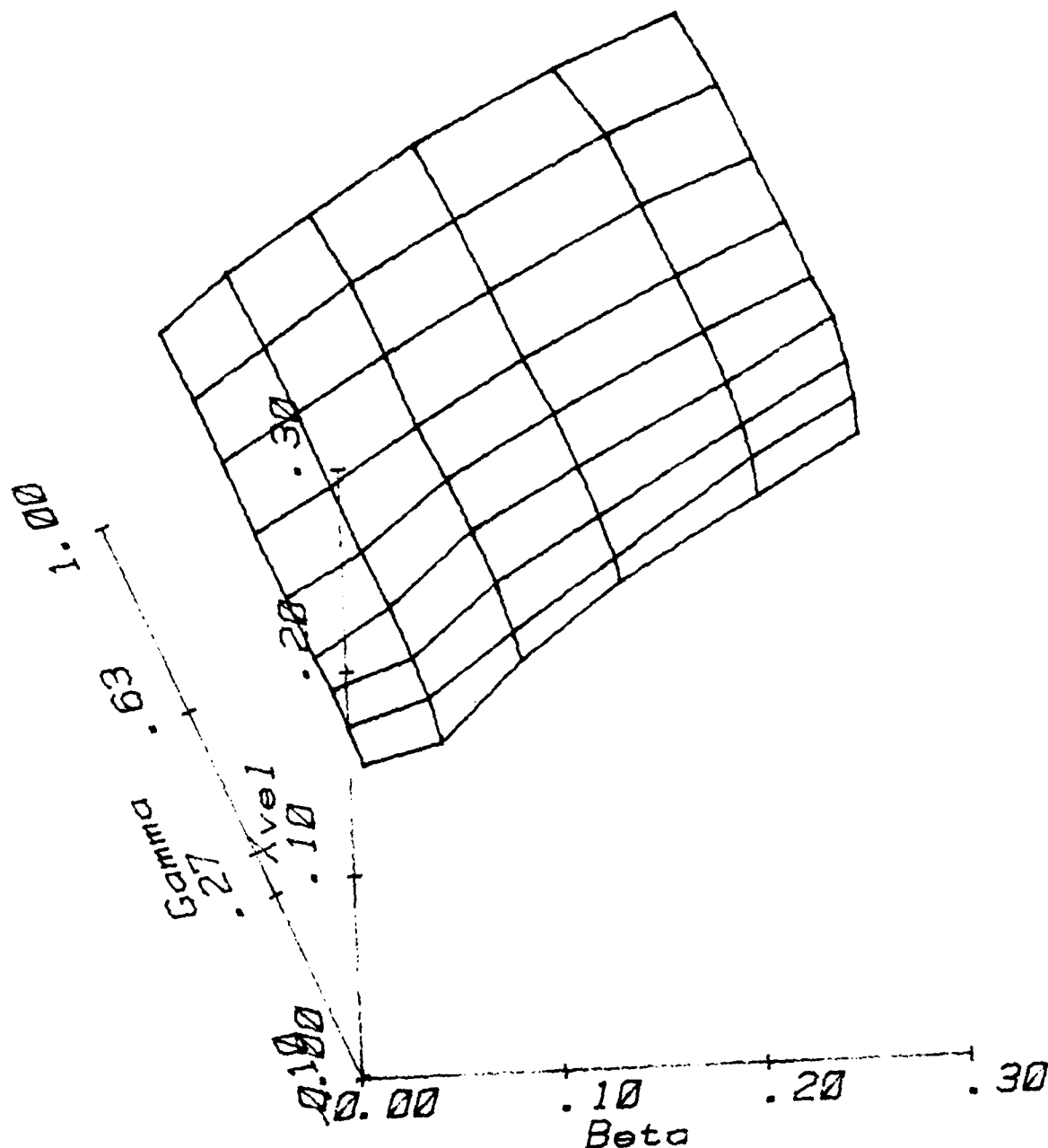

Figure 15a. Approximation of Dimensionless Velocity, X , as Function of Coefficients β and γ .

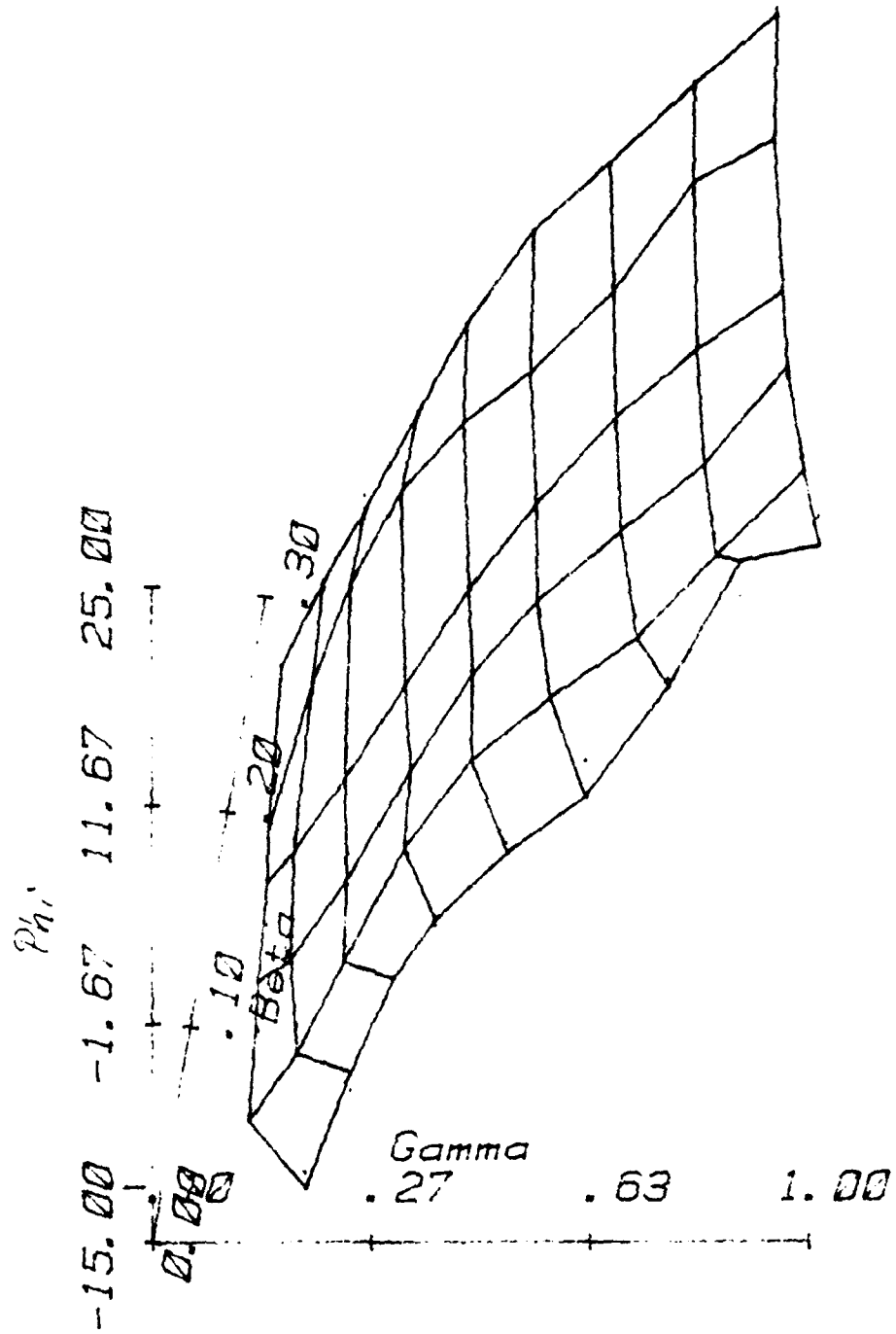

Figure 15b. Approximation of Pitch angle ϕ as Function of Coefficients β and γ .

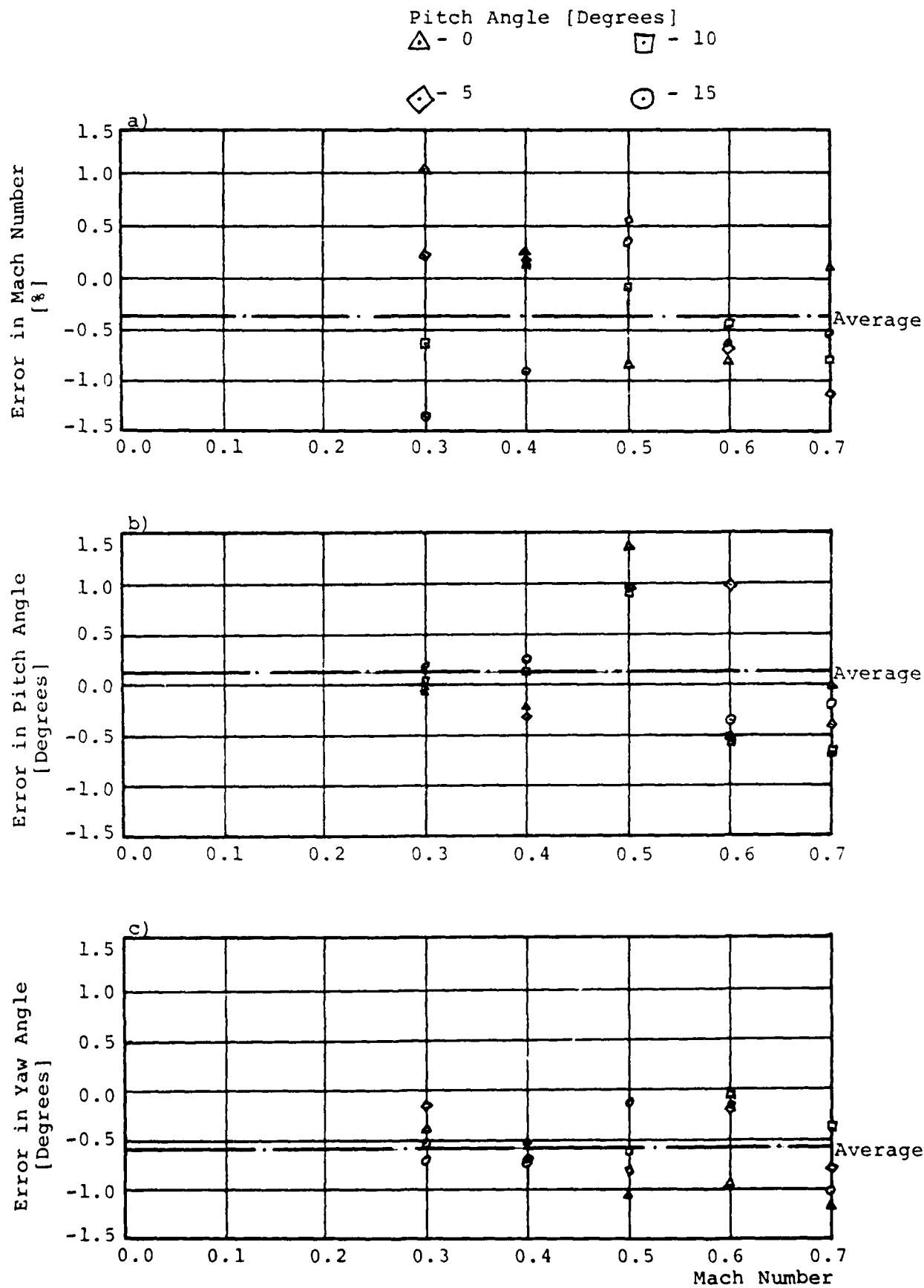

Figure 16. Errors as Specified Depending on Mach Number and Pitch Angle.



Figure 17. Combination Pressure Temperature Probe
(Tip Detail)

AD-A136 350

FURTHER DEVELOPMENT OF A DUAL-PROBE DIGITAL SAMPLING
(DPDS) TECHNIQUE FOR... (U) BDM CORP MONTEREY CA
F NEUHOFF SEP 82 NPS-67-82-01CR N00014-79-C-0088

23

UNCLASSIFIED

F/G 14/2

NL

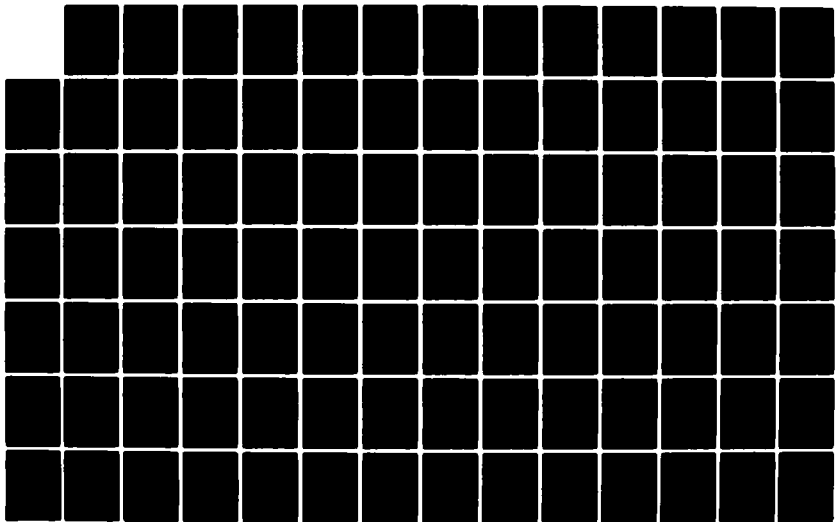

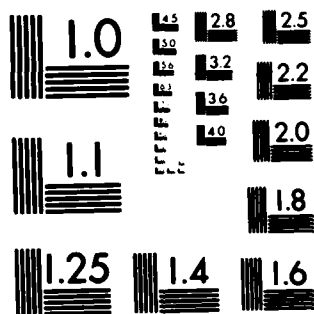

MICROCOPY RESOLUTION TEST CHART
NATIONAL BUREAU OF STANDARDS 1963-A

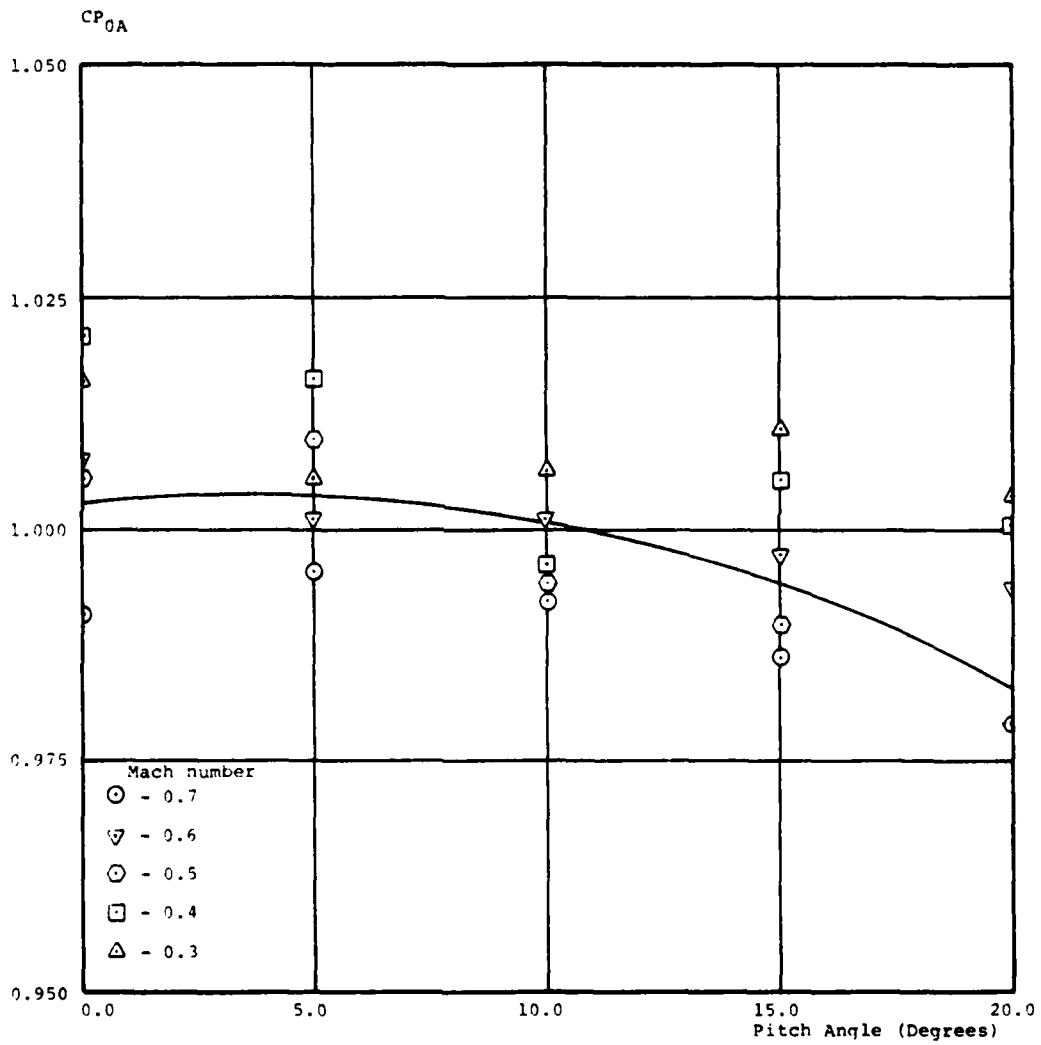

Figure 18. Pressure Coefficient for Type A-Probe at Zero Yaw Angle as Function of Mach Number and Pitch Angle.

$C_{p_{OB}}$

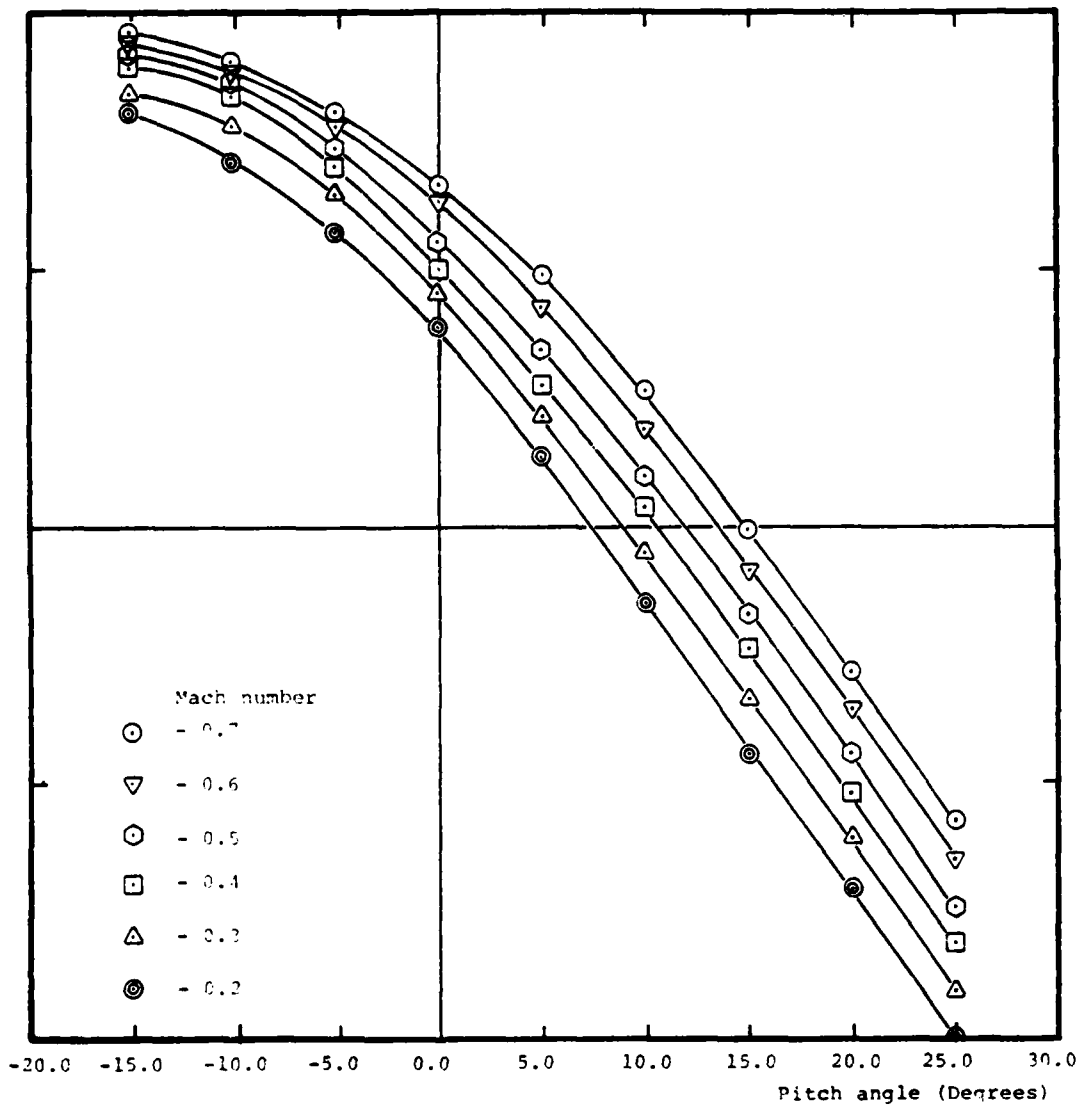
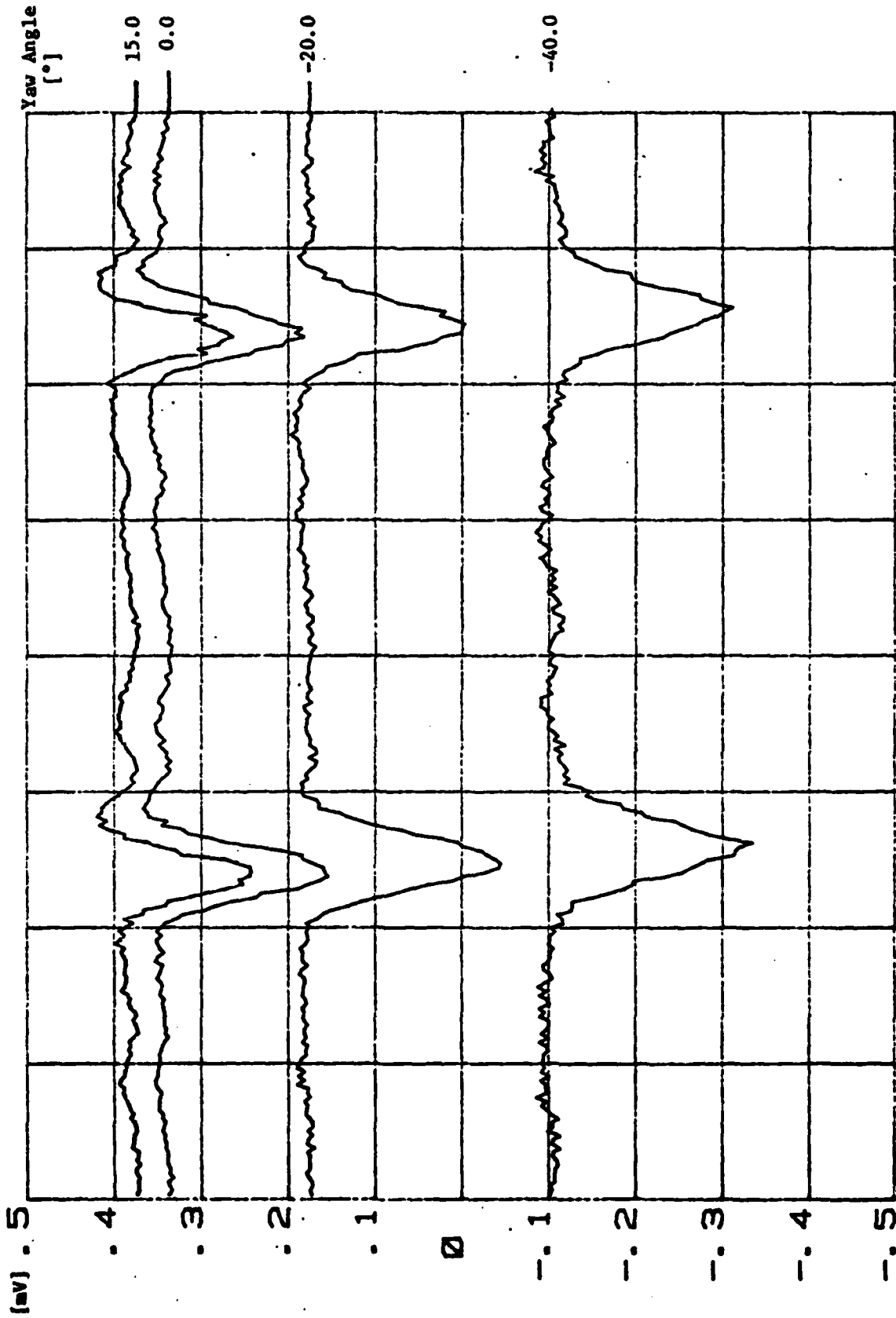

Figure 19. Pressure Coefficient for Type B-Probe for Zero Yaw Angle as Function of Mach Number and Pitch Angle.

A-probe raw data
File: AB19A1



0 0 32.0 64.0 96.0 128.0 160.0 192.0 224.0 256.0 Position

A-probe raw data
File: AB19A1

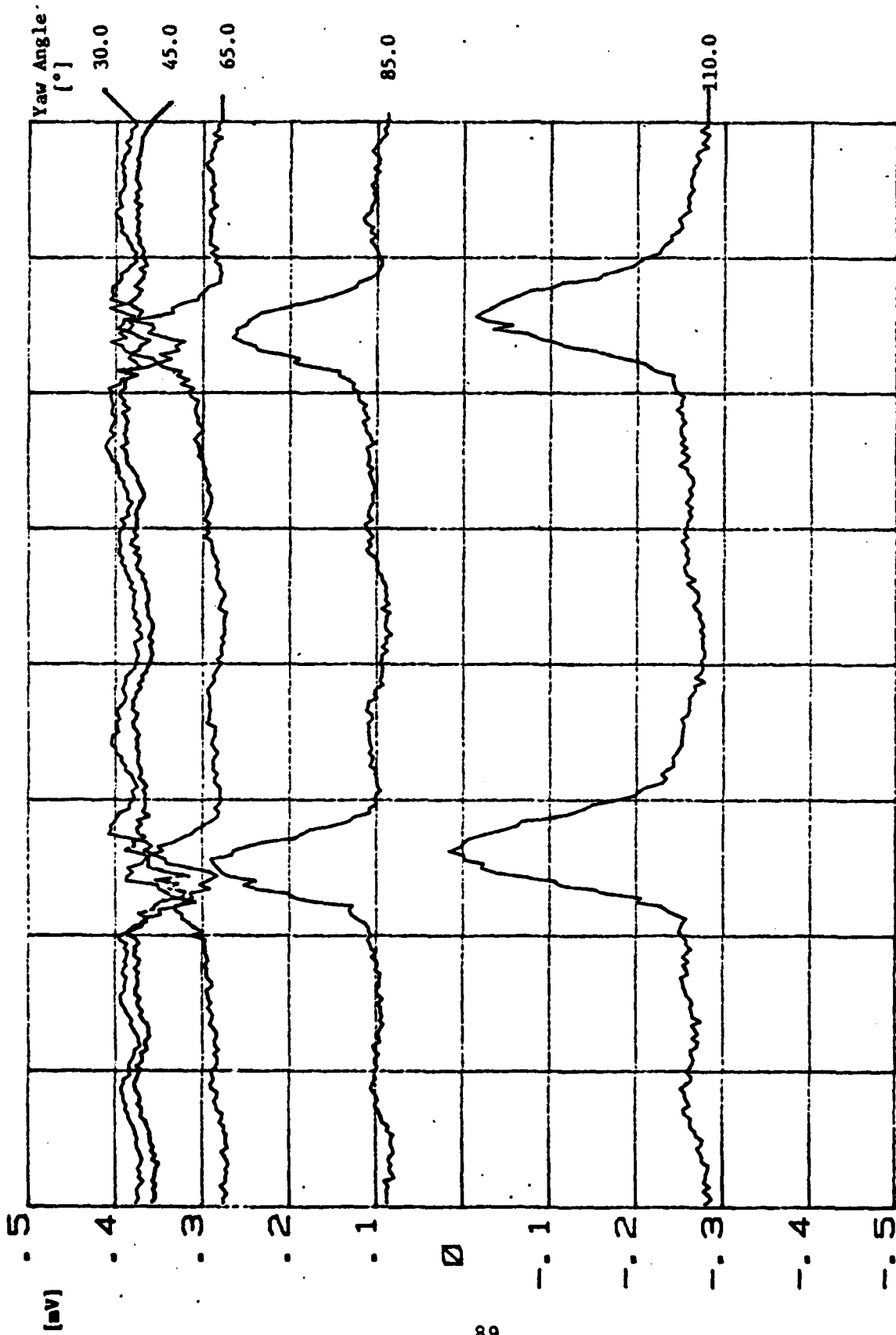

0. 0 32. 0 64. 0 96. 0 128. 0 160. 0 192. 0 224. 0 256. 0

Position

Figure 20b. Paced Data From Type A Probe. Probe Yaw Angle Settings as Indicated.

B-probe raw data
File: AB19B1

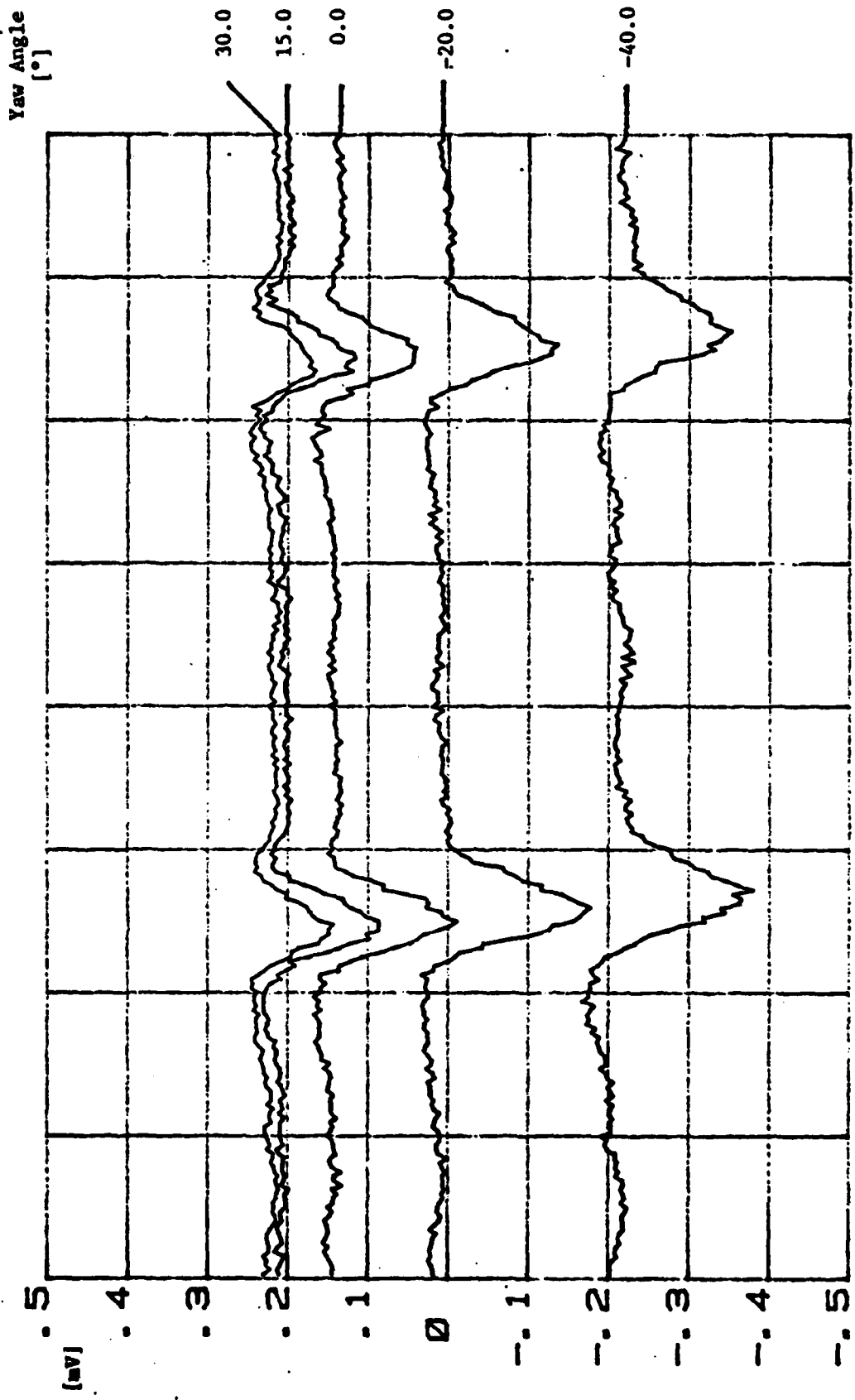

0.0 32.0 64.0 96.0 128.0 160.0 192.0 224.0 256.0

Figure 20c. Paced Data from Type B-Probe.
Probe Yaw Angle Settings are Indicated.

Position

B-probe raw data
File: AB19B1

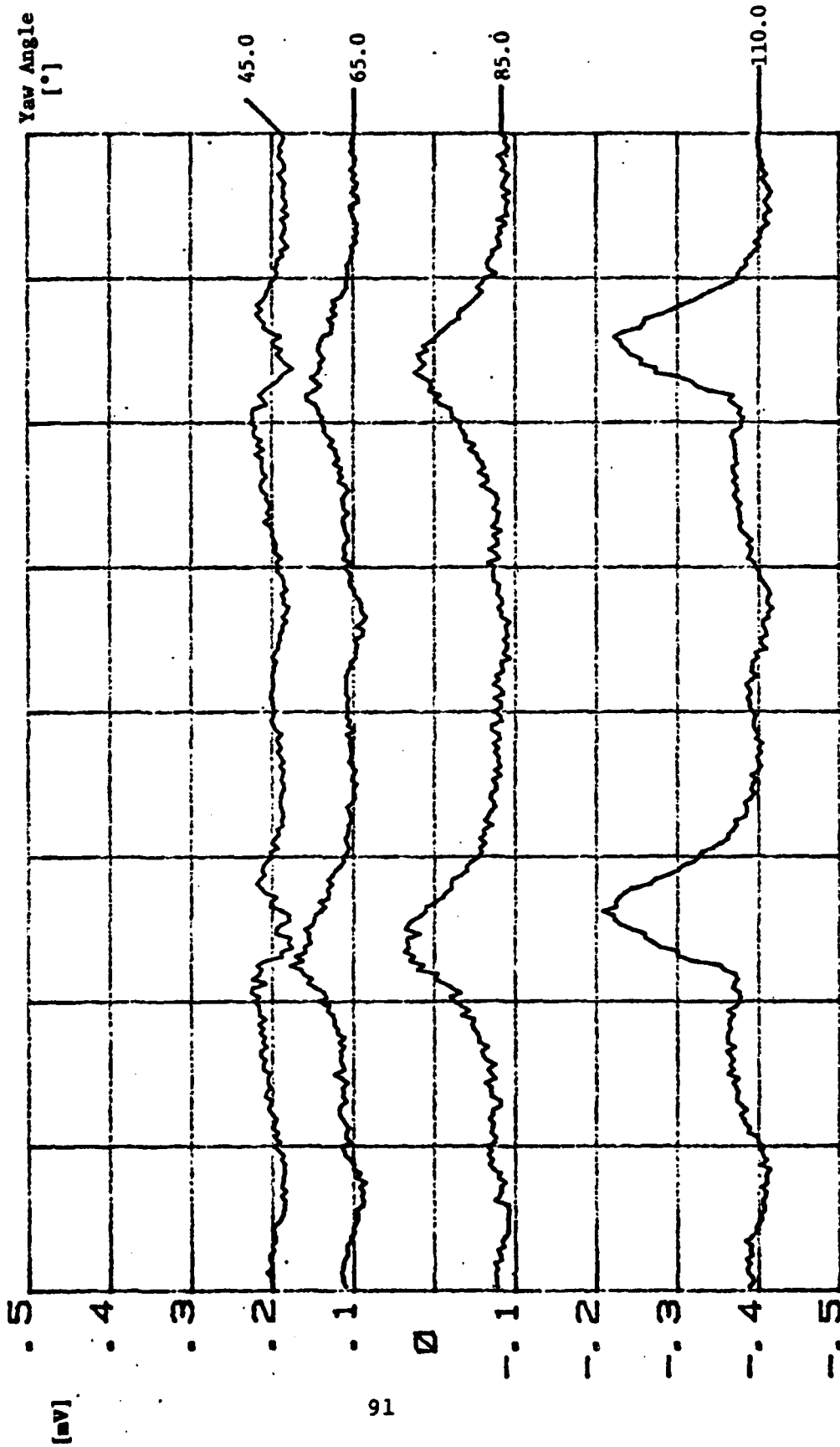

0.0 32.0 64.0 96.0 128.0 160.0 192.0 224.0 256.0
Position

Figure 20d. Paced Data from Type B-Probe
Probe Yaw Angle Settings as Indicated.

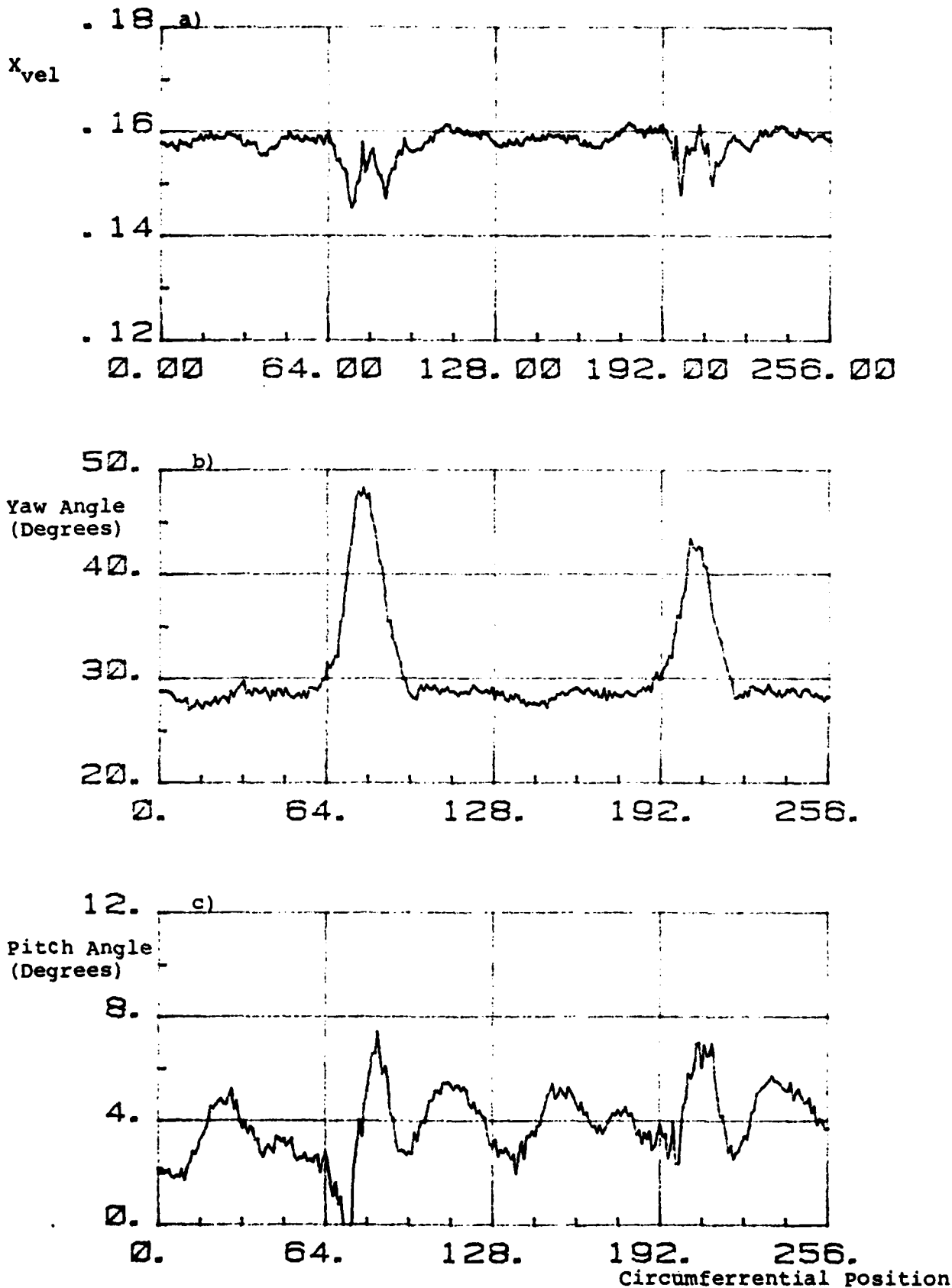

Figure 21. Measurement Results at 50% Speed, Midspan, Peak Efficiency (File AB19R1).

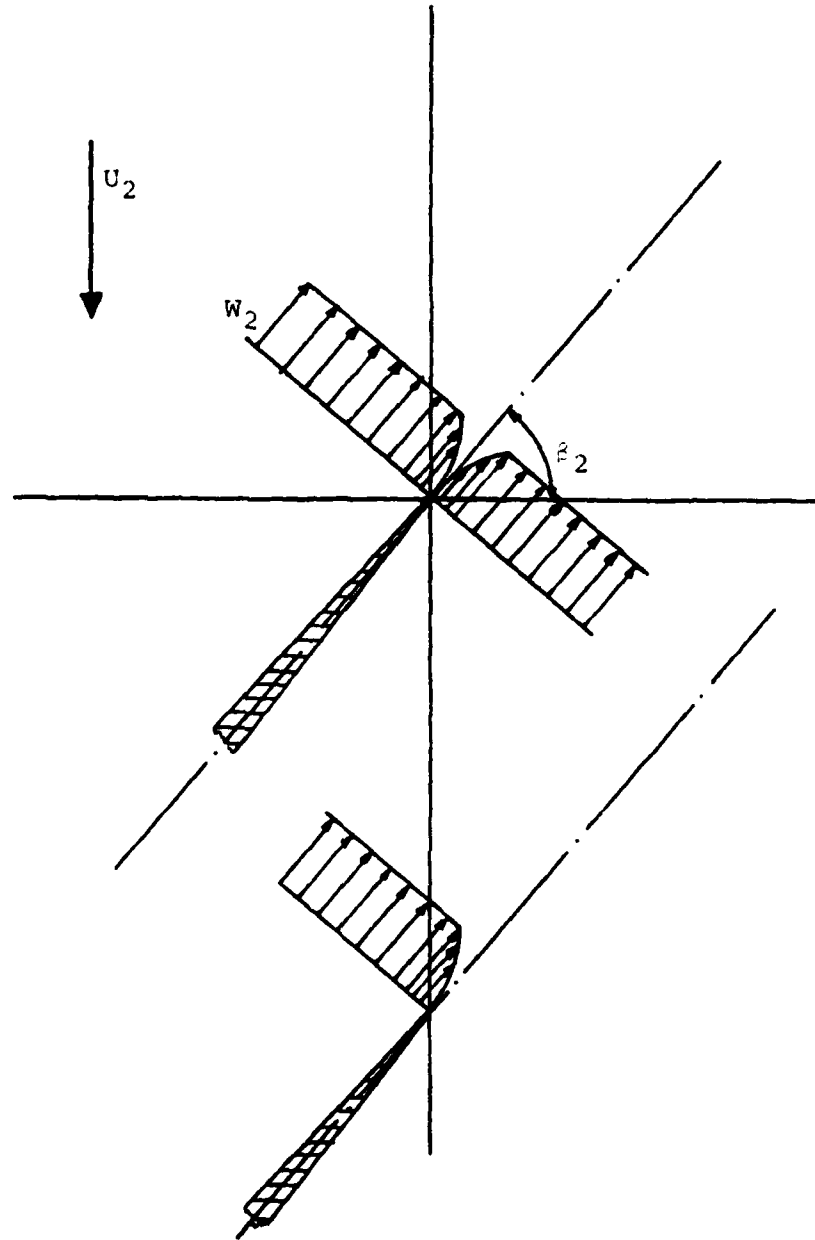
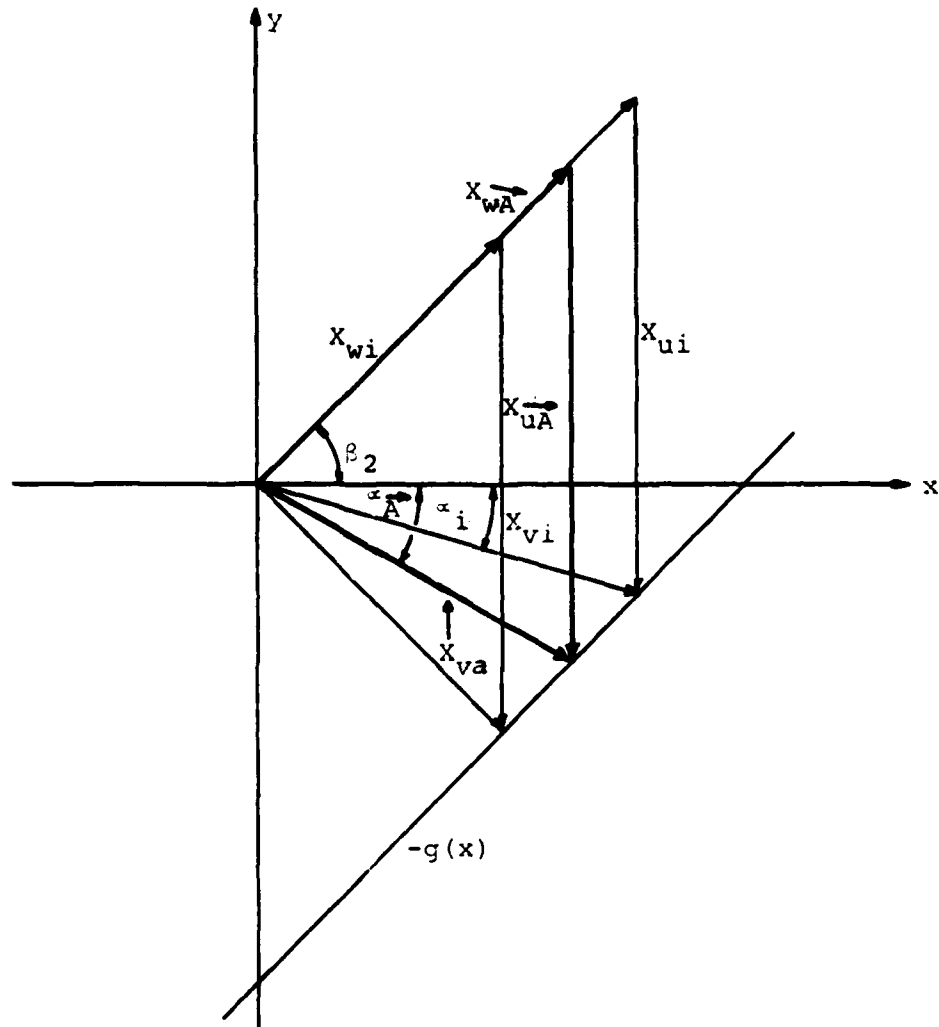

Figure 22. Relative Velocity Distribution W_2 at Rotor Trailing Edge (Schematic)

$$\beta_2 = \text{const.}$$

$$U_2 = \text{const.}$$



$$\begin{aligned}
 y(x_1) &= X_{uA} + \tan \beta_2 x_1 & -X_{v_1} \sin \alpha_1 &= -X_{u_1} + \tan \beta_2 X_{v_1} \cos \alpha_1 \\
 x_1 &= X_{v_1} \cos \alpha_1 & X_{uA} &= X_{u_1} = X_u \\
 y_1 &= X_{v_1} \sin (360^\circ - \alpha_1) & X_{v_1} &= \frac{X_u}{\tan \beta_2 \cos \alpha_1 + \sin \alpha_1} \\
 y_1 &= (-X_{v_1}) \sin \alpha_1
 \end{aligned}$$

Figure 23. Velocity Triangles for Varying Values of the Relative Velocity X_w .

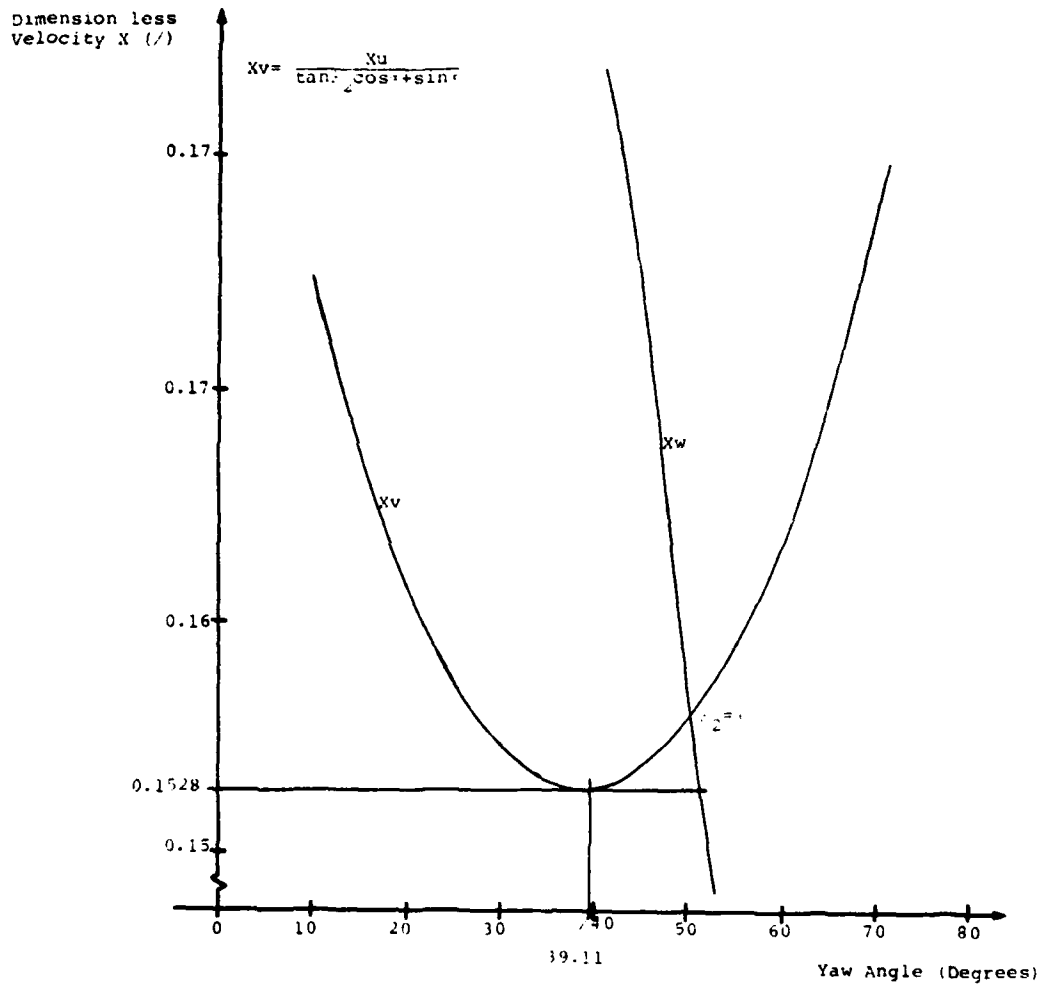

Figure 24. Dependence of Absolute (X_v) and Relative (X_w) Velocities on Yaw Angle (α) Assuming Constant Values of Circumferential Velocity ($X_u=0.24219$) and Relative Flow-Angle ($\beta_2=50.39^\circ$).

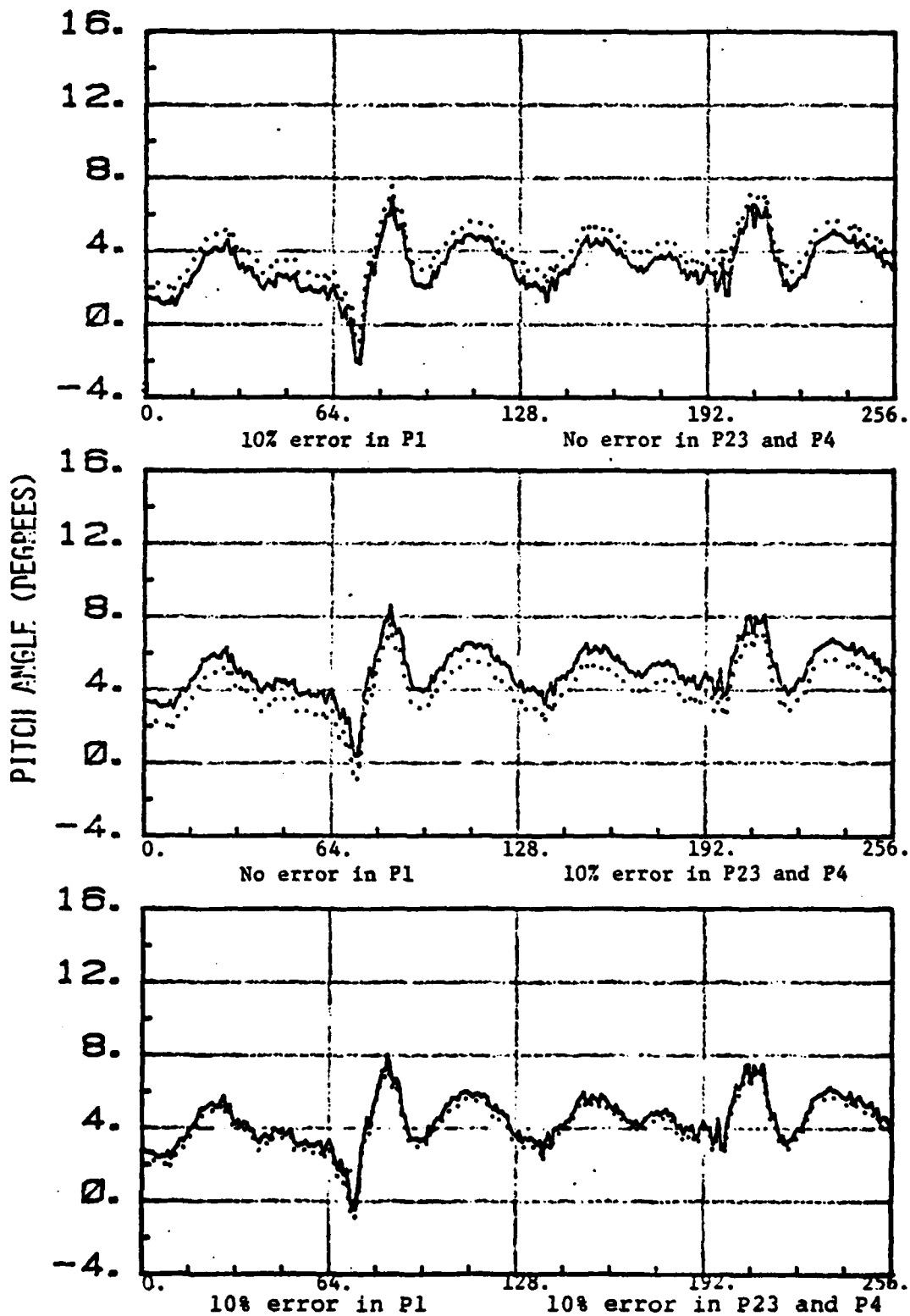

Figure 25. Influence of Incorrect Pneumatic Probe Pressure Readings Run 119, 50% Design Speed, Near Peak Efficiency, Dotted Line - No Errors.

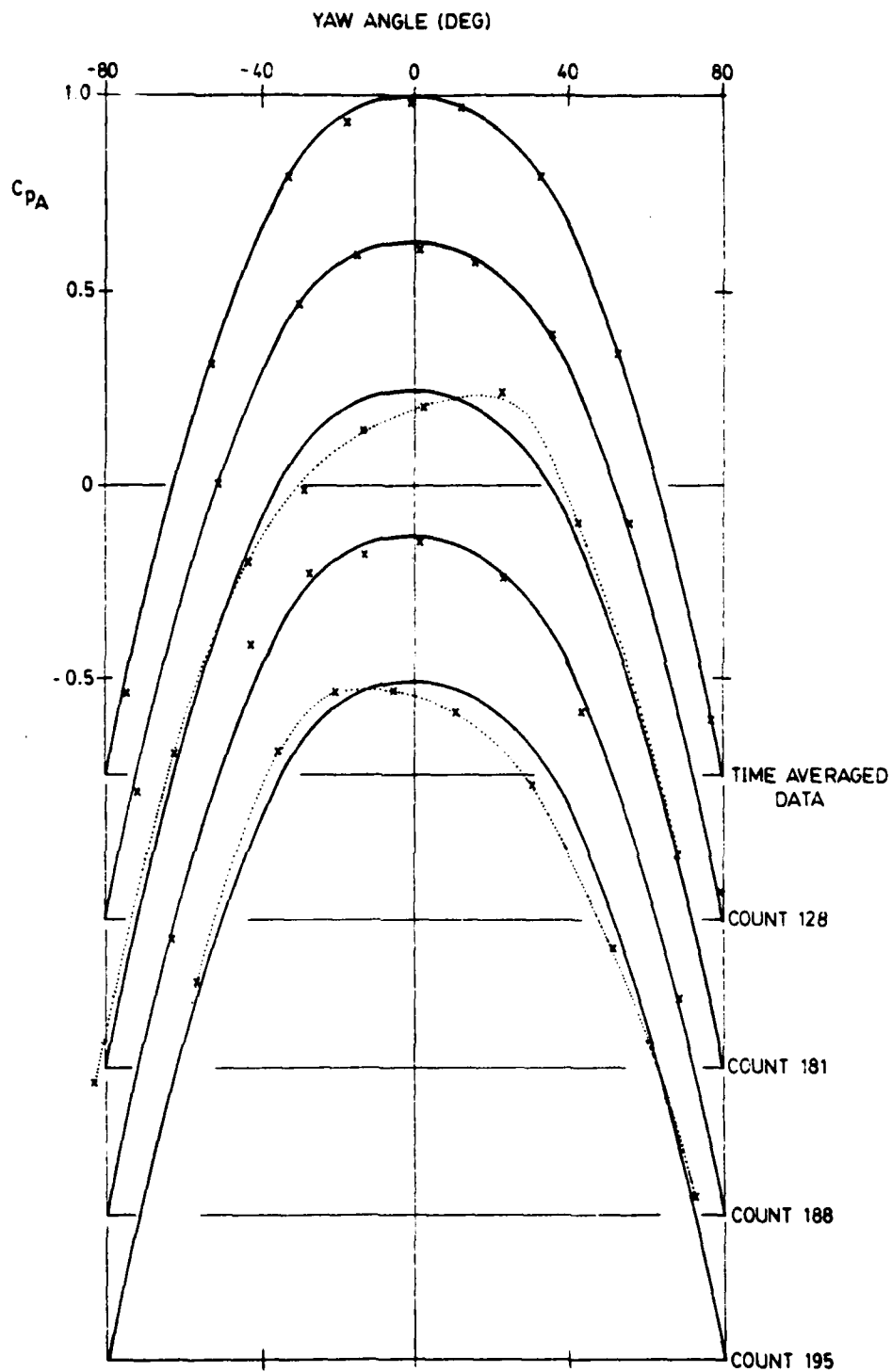

Figure 26. Pressure Coefficient Versus Yaw Angle for Type A Probe at Specific Positions in Rotor Flow Field (Run 123 - solid line is from calibration at $M = 0.4$, $\phi = 0^\circ$).

APPENDIX A

CHANGES MADE TO SOFTWARE FROM (Ref. 4)

The changes made by McCarville and reported in Ref. 4 brought about two general improvements: hardware changes which eliminated the need for an operator-performed lock-on procedure and software changes which allowed the acquisition of one sample for each consecutive revolution instead of every tenth or eleventh as before. In the process of integrating the new software into the data acquisition program, one minor and one significant error was found in the subroutines used for acquiring data through the A/D converter.

The data is transferred from the A/D converter to the 21MX computer in 16-bit words. Only the highest 10 bits contain the digitized voltage while the A/D channel number (0 through 15) is transferred in the lowest 4 bits. Using the highest bit for the sign, the range of numbers which can be transferred is thus $\pm(2^{15}-1)$ or $\pm 32,767$, while the smallest meaningful division is 2^6 or 64. The resolution which can be achieved therefore is $\frac{2^6}{2^{16}}$ or 2^{-10} or 0.000976 of full range. Since the full range of the A/D is -1V to +1V, the instrument resolution is to about 2 mV.

The procedure of masking can be used to derive an exact digital number solely from the highest 10 bits of the transmitted word. If this is not done, the A/D channel number from the low bits is included when converting the data word to a decimal number. The result is to create decimal numbers which appear

to be changing with a resolution of 2° is $\pm 32,767$ or 0.0305 mvs. Since the increase in program running time due to masking was insignificant, this procedure was built into the data acquisition program.

The second error was found while using the data acquisition program. It was noted that a different number of samples acquired from the same machine conditions did not bring any significant change in the smoothness of the output. An examination of the output of 5 individual samples (Table A-I) and the average derived from these samples showed that only the first sample was converted from an integer into a real number and that the same real number resulted for each individual sample no matter what was the value of the integer.

Figure A-1 shows the listing of the original subroutine (RSPACE) from McCarville which acquires raw data. The single samples are read into array Ibuff(99) correctly (lines #90 and #125). The conversion into real numbers is incorrect, in that only the first value of the array Ibuff(99) is converted.

Figure A-2 shows the corrected DO-loop.

Table A-II shows values achieved using the corrected subroutine. It can be seen that changes in the integer numbers are reflected in the calculated real numbers.

In the acquisition program discussed herein a subroutine similar to the one of Fig. A-2 was used.

REP	+	1	IBUF	=	-29736	RBUF	=	-1.876957
REP	+	2	IBUF	=	-29608	RBUF	=	-1.873047
REP	+	3	IBUF	=	-29736	RBUF	=	-1.876957
REP	+	4	IBUF	=	-29608	RBUF	=	-1.873047
REP	+	5	IBUF	=	-29608	RBUF	=	-1.873047
POINT	+	1	Y(I)	=	-1.874609			
REP	+	1	IBUF	=	-29430	RBUF	=	-1.869141
REP	+	2	IBUF	=	-28416	RBUF	=	-1.837188
REP	+	3	IBUF	=	-28408	RBUF	=	-1.849141
REP	+	4	IBUF	=	-28352	RBUF	=	-1.852334
REP	+	5	IBUF	=	-28416	RBUF	=	-1.857188
POINT	+	1	Y(I)	=	-1.847579			
REP	+	1	IBUF	=	-29160	RBUF	=	-1.859375
REP	+	2	IBUF	=	-28976	RBUF	=	-1.857322
REP	+	3	IBUF	=	-29160	RBUF	=	-1.859375
REP	+	4	IBUF	=	-28976	RBUF	=	-1.857322
REP	+	5	IBUF	=	-28224	RBUF	=	-1.851728
POINT	+	1	Y(I)	=	-1.858984			
REP	+	1	IBUF	=	-27904	RBUF	=	-1.851563
REP	+	2	IBUF	=	-27712	RBUF	=	-1.845793
REP	+	3	IBUF	=	-27840	RBUF	=	-1.849699
REP	+	4	IBUF	=	-27776	RBUF	=	-1.847656
REP	+	5	IBUF	=	-27776	RBUF	=	-1.847656
POINT	+	1	Y(I)	=	-1.848432			
REP	+	1	IBUF	=	-27264	RBUF	=	-1.832031
REP	+	2	IBUF	=	-27392	RBUF	=	-1.835938
REP	+	3	IBUF	=	-27456	RBUF	=	-1.837891
REP	+	4	IBUF	=	-27392	RBUF	=	-1.835938
REP	+	5	IBUF	=	-27520	RBUF	=	-1.839844
POINT	+	1	Y(I)	=	-1.836328			

Table A-II. Results Using Corrected Subroutine RPACE (&A2D, McCarville, Ref. 4)

```

0121      11.111 11.111
0122      11.111 11.111
0123      11.111 11.111
0124      11.111 11.111
0125      11.111 11.111
0126      11.111 11.111
0127      11.111 11.111
0128      11.111 11.111
0129      11.111 11.111
0130      11.111 11.111

```

Figure A-2. Corrected Statement of Subroutine
 RSPACE from Program &A2D (P. McCarville, Ref. 4)

APPENDIX B

OUTPUT CHARACTERISTICS OF TYPE "A" AND TYPE "B" PROBES

The DPDS, measurements are carried out using two different kinds of pressure probes. The type "A" probe is essentially a total pressure probe (see Fig. 4). The general behavior of such a probe with respect to angle changes has been established for quite some time (Ref. 10). However, using a pneumatic equivalent probe to the "A" probe the output of the probe as a function of yaw angle was established with the probe mounted in the steady flow of a freejet.

Figure B-1 shows this dependence. The characteristics of this curve are a flat top, indicating an insensitivity of the probe to yaw angle changes of up to $\pm 20^\circ$ from the zero yaw angle position, and the steep but almost linear parts from -70° to -40° and $+40^\circ$ to $+70^\circ$. At yaw angles of -63° and $+63^\circ$ the probe reads static pressure and that happens independent of Mach number and pitch angle as long as the pitch angle does not exceed a range of -5° to about $+15^\circ$.

Figure 9 shows the output of the type "A" probe for different pitch angle settings but one Mach number only. It can be seen that pitch angles ranging from -15° to $+25^\circ$ at a 5° increment produce almost identical curves.

Figure 12 shows the output of the type "B" probe for the same Mach number and the same range of pitch angle. It can be seen that, compared to the "A" probe

probe does not have a flat top for a range of measurement close to the zero yaw angle (zero being the yaw angle where the probe is aligned with the flow). Instead it shows a clear and well-defined maximum in output for the zero yaw angle. It is also evident that the output depends very clearly on the pitch angle. The yaw angle where the probe reads static pressure is different for different pitch angles and Mach numbers. Different Mach numbers always show only one curve for the "A" probe (independent of pitch angle) while the "B" probe depends on changes of both Mach number and pitch angle .

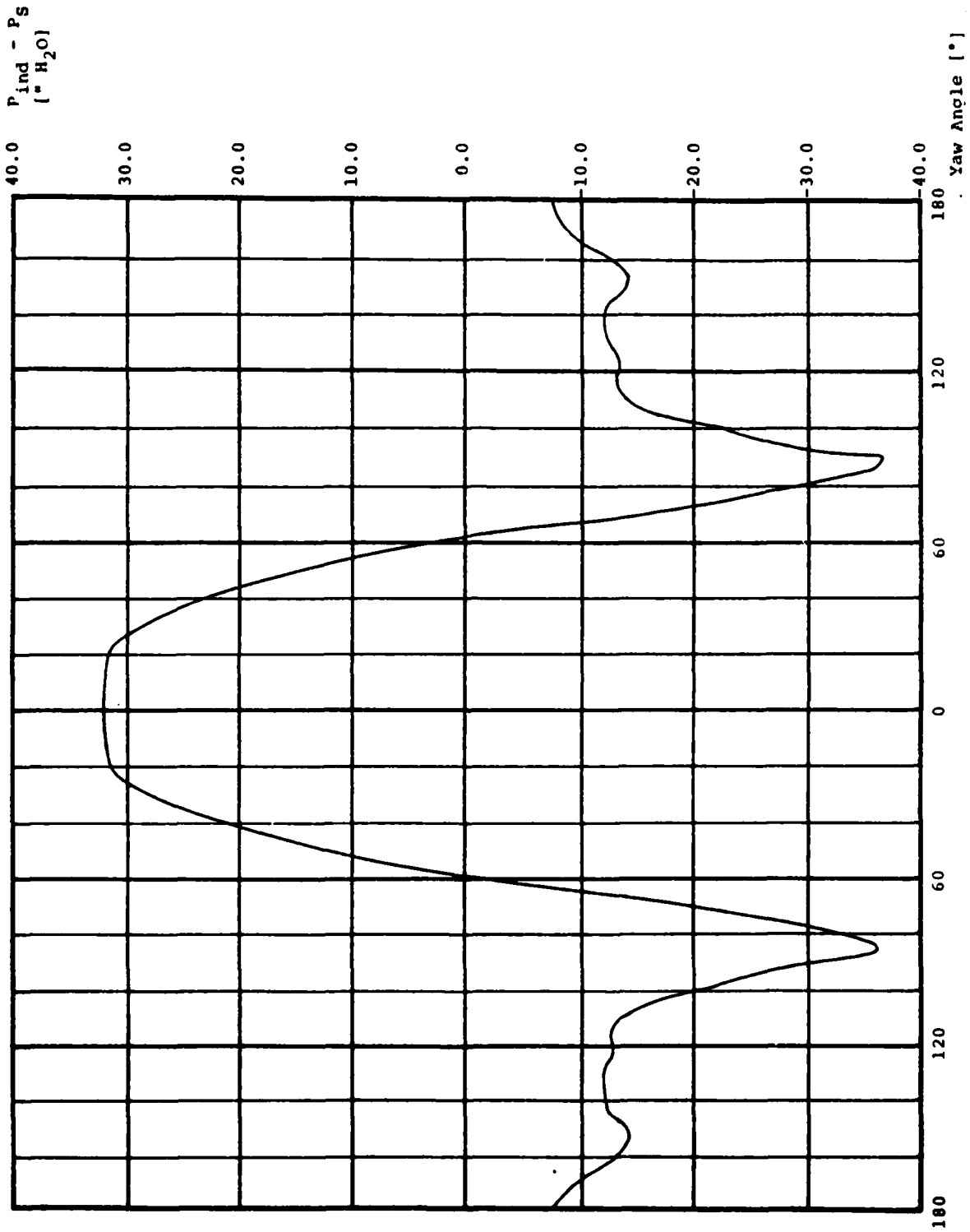

Figure B-1. Indicated Pressure Versus Yaw Angle for a Pneumatic Probe Equivalent to a Type A Probe. Dynamic Head = 32 " H₂O. Free Jet Flow, Zero Degrees Pitch Angle.

APPENDIX C

DATA ACQUISITION PROGRAMS &KALIB AND &YAW

The purpose of both programs--&YAW and &KALIB--is to acquire sufficient data for the calibration of either the type "A" or "B" probe. It has to be mentioned here that only one probe can be mounted in the center of the freejet at a time. It is therefore essential to establish identical conditions for the calibration of both probes.

Since the data reduction as outlined in 4.1 requires not only the knowledge of Mach number and pitch angle, but also the probe output characteristic as a function of yaw angle, data is acquired for different yaw angle settings. Here is the major difference between programs &YAW and &KALIB. While program &YAW requires the data acquisition at one specific yaw angle setting, &KALIB acquires data in a continuous mode for a range of 160° (-80° to $+80^{\circ}$) in yaw angle.

However, program &YAW will be described first, since it is the more conventional one.

C-1. PROGRAM &YAW

Since parameters have to be changed during a calibration, the program has to work interactively with operator input. For each selected combination of Mach number and pitch angle data can be recorded for up to 31 probe yaw angle settings. For any of these settings the values of total pressure, Kulite reference pressure, probe yaw angle and Kulite

pressure reading are acquired as the average of 10 data samples each. The pitch angle is keyed in by the operator prior to the measurement and the total temperature and the barometric pressure (static pressure since it is a freejet) are measured also. When the data for one yaw angle position is taken the operator is asked to have the probe moved to another yaw angle and initialize the data acquisition process again.

Once the data for all 31 yaw positions are taken, the operator is asked to key in a file name. The raw data from this calibration is then stored in a file with the name previously assigned.

In the next step absolute values for the total temperature (degrees Fahrenheit) and the static pressure (inches Hg) are calculated. File name, pitch angle, total temperature and static pressure are written on the line printer. The following DO-loop derives absolute values of the impact pressure (inches of water), the Kulite reference pressure (inches of water), the probe yaw angle (degrees), and the Kulite pressure output (inches of water) as a gage pressure. From these values a pressure coefficient c_p defined as

$$c_p = \frac{p_K + p_{ref} - p_s}{p_t - p_s}$$

where p_K = Kulite pressure

p_{ref} = Kulite reference pressure

p_t = total pressure

p_s = static pressure

is derived. All of these values are tabulated.

A plot of c_p vs yaw angle is produced automatically with the operator's choice of drawing a full grid or just the calibration result.

After this the program can either be stopped or started again for a different flow condition.

C-1 gives a flow chart, while C-2 is a program listing.

Externals: ABRT, CLEAR, CLOSE, CPLOT, CREAT, DRAW, FXD, LABEL, LDIR, LOCL, MOVE, OPEN, PLOTR, RMOTE, SCANR, SETAR, VIEWP, WINDW, WRITF

<u>Variables</u>	<u>Type</u>	<u>Description</u>
CDATA(32)	Real	Array containing pressure coefficients c_p
DATA(32,4)	Real	Array containing complete raw calibration data
ICR	Integer	Cartridge reference number
IDCB(144)	Integer	Data control block
IFILE(3)	Integer	Array containing file name
IGCB(192)	Integer	Graphic data control block
IL	Integer	Total number of words to be stored in raw data file (two words for one data value)
ISECU	Integer	Security code
ISIZE(2)	Integer	Array to specify file dimensions (1st word for number of records, 2nd for record length)
ITYPE	Integer	Type of data file
S		total pressure
T		Kulite ref. pressure
U	Real	Sample readings of probe yaw angle
V		Kulite output
W		total pressure
X		Kulite ref. pressure
Y	Real	Average values of probe yaw angle
Z		Kulite output

C-2. PROGRAM &KALIB

As stated earlier this program records probe data for more yaw positions than program &YAW. Once either the "A" or the "B" probe is mounted on the freejet and the desired flow condition (Mach number and pitch angle) is established, the actual pitch angle is keyed in, and single measurements of total temperature and pressure as well as Kulite reference pressure and barometric pressure are taken. The operator is then asked to start the data acquisition process for the Kulite pressure/yaw angle measurement. Simultaneously the operator has to signal that the probe shall be rotated in the freejet. While the probe is rotated from -80° to $+80^{\circ}$ in yaw at a constant rate of $\sim 3^{\circ}/\text{sec}$, the yaw position and the corresponding Kulite pressure reading is recorded alternately. When the whole range of yaw angle is finished, the flow conditions are recorded again and the probe is rotated backwards 160° with the same data acquisition process as before. Then the jet conditions are recorded a third time. All raw data is multiplied by its corresponding scaling factor. The total temperature is calculated in degrees Fahrenheit. A pressure coefficient as defined in C-1 is derived for all 300 points of measurement. The whole data array (contents are defined in the listing) is stored in one file with its name as operator input. A complete output of the file contents is printed. (Note: line printer must be set to "comp".)

The operator is then asked to specify the form of a plot of the just-acquired data. When the plot is completed the operator has the choice of stopping the program or performing another data acquisition for a different flow condition.

C-3 gives a flow chart of &KALIB while C-4 is a program listing.

Externals: ABRT, CLEAR, CLOSE, CPLOT, CREAT, DRAW, FXD, LABEL, LDIR, LOCL, MOVE, OPEN, PLOTR, RMOTE, SCANR, SETAR, VIEWP, WINDOW, WRITF

<u>Variables</u>	<u>Type</u>	<u>Description</u>
CDATA(300)	Real	Array containing pressure coefficients C_p
DATA(2,320)	Real	Array containing complete raw calibration data
ICR	Integer	Cartridge reference number
IDCB(144)	Integer	Data control block
IFILE(3)	Integer	Array containing file name
IGCB(192)	Integer	Graphic data control block
IL	Integer	Total number of words to be stored in raw data file (two words for one data value)
ISECU	Integer	Security code
ISIZE(2)	Integer	Array to specify file dimensions (1st word for number of records, 2nd for record length)
ITYPE	Integer	Type of data file

By comparison of sets of data acquired with both programs for the same flow conditions, no difference was found between the results of the two programs.

Since program &KALIB offers much more overall information in even shorter time, it was used for the whole calibration of both probes with occasional comparisons between the two program results. Plots of the probe outputs vs yaw angle were produced and stored for each of the conditions to have an easy and clear idea of the probe's general behavior.

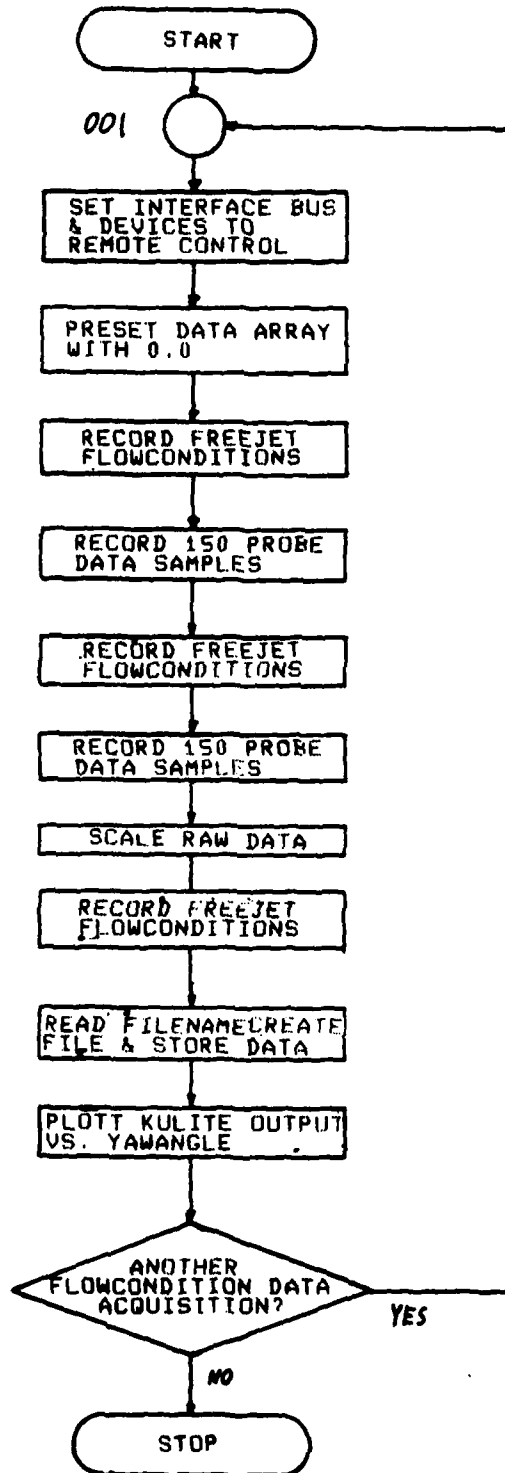

Figure C-1. Flow Chart of Data Acquisition Program & Yaw

```

&YAW T=00004 IS ON CR00026 USING 00025 BLKS R=0000

0001 FTN4,L
0002 PROGRAM YAW
0003 REAL DATA(32,4),CADATA(32)
0004 DIMENSION ICCB(16),IDCB(144),IFILE(3),ISIZE(2)
0005 DATA ICCB/144/
0006 DATA ISECU/0/
0007 DATA ICR/29/
0008 DATA ITYPE/1/
0009 DATA ISIZE/2,128/
0010 DATA IL/256/
0011
0012 .....
0013 PROGRAM TO ACQUIRE DATA FOR THE CALIBRATION OF A KULITE PROBE
0014 THIS PROGRAM TAKES DATA AT DEFINED YAW POSITIONS.
0015 ONLY THE RAW DATA IS STORED.
0016 .....
0017
0018 101 FORMAT (" READ PITCHANGLE FROM TERMINAL")
0019 102 FORMAT (I4)
0020 103 FORMAT (" WHEN YOU ARE READY FOR THE "I4". MEASUREMENT, HIT CR")
0021 104 FORMAT (" Pt tunnel="F8.6" P ref.="F8.6" Probe pos.="F8.6" Kulite
0022 "P ref.="F8.6")
0023 105 FORMAT (" ENTER THE FILE NAME YOU WANT THE RAW DATA TO BE STORED I
0024 " ")
0025 106 FORMAT (" IF YOU NEED A COMPLETE NEW FRAME, KEY YE "" ANY OTHER Y
0026 " KEY IF NO """)
0027 107 FORMAT (" IF YOU WANT ANOTHER SET OF DATA FOR A DIFFERENT PITCH ANGL
0028 "E, KEY YES "" ANYTHING ELSE, IF NOT """)
0029 149 FORMAT ("J3")
0030 601 FORMAT (" NO DATA ARE STORED IN FILE : "I4,3A2/)
0031 602 FORMAT (" B="I4" Tunnel Temp.="F8.2" P baro="F8.5//")
0032 603 FORMAT (" P="F8.6" YAW Kulite out P ref. Pt tunnel="I4"
0033 "P//")
0034 634 FORMAT (I4,I4,F7.3,3(I4,F12.6),6X,F12.6)
0035 801 FORMAT("CA")
0036 1001 FORMAT("F1R7M3A1M0T3")
0037 1002 FORMAT("F1R7M3A0M0T3")
0038 1111 FORMAT(" "I5" IERR ="I5,F12.4)
0039 1301 FORMAT("B-PROBE PITCH="I4,10X"P BARO ="F7.3)
0040 1302 FORMAT("TUNNEL TEMPERATURE="F7.3,2X"FILE : "3A2)
0041 1303 FORMAT(" CP")
0042 1501 FORMAT("CA")
0043
0044 .....
0045 DATA LOCATION IN THE DATA FILE :
0046
0047 FOR I = 1 TO 31, I IS THE NUMBER OF THE YAW ANGLE.
0048 FOR EACH OF THESE YAW ANGLES THE ARRAY CONTAINS THE FOLLOWING
0049 VALUES IN THE GIVEN ORDER:
0050
0051
0052
0053
0054
0055
0056
0057
0058
0059
0060
0061
0062
0063
0064
0065
0066
0067
0068
0069
0070
0071
0072
0073
0074
0075
0076
0077
0078

```

	1	2	3	4
0053	0 1 Pt tunnel	P ref. Kulite	Probe position	Kulite Press.
0054	0 2	.	.	.
0055
0056
0057	0 31	.	.	.

```

0060 DATA(32,1) contains pitchangle input from terminal
0061 DATA(32,2) contains Pt tunnel read from scanner 02 ch 6
0062 DATA(32,3) contains P baro read from scanner 01 ch 25
0063
0064 CALL ABRT(7,3)
0065 CALL RMOTE(8)
0066 CALL RMOTE(10)
0067 CALL RMOTE(15)
0068 WRITE (8,801)
0069 WRITE (10,1001)
0070 WRITE (15,1501)
0071
0072 .....
0073 PRESET DATA ARRAY WITH 0.0 !
0074 .....
0075
0076 DO 002 I = 1,32,1
0077
0078

```

Figure C-2. Listing of Calibration Data Acquisition Program &YAW. (Continued on next page.)

```

079 DATA(I,1) = 0.0
080 DATA(I,2) = 0.0
081 DATA(I,3) = 0.0
082 DATA(I,4) = 0.0
083 DATA(32,2) = SCANNR(15,06,01)
084 DATA(32,3) = SCANNR(08,25,01)
085 WRITE(1,101)
086 READ(1,102) DATA(32,1)
087 WRITE(10,1002) DATA(32,1)
088 DO 010 I = 1,31,1
089 WRITE(1,103) I
090 READ(1,149) IDUM
091 IF (IDUM.NE.2H ) GOTO 003
092 M = 0
093 X = 0
094 Y = 0
095 Z = 0
096
097 DO 008 J = 1,10,1
098 S = SCANNR(15,20,01)
099 W = M + S
100 T = SCANNR(15,21,01)
101 X = X + T
102 U = SCANNR(15,22,01)
103 Y = Y + U
104 V = SCANNR(15,23,01)
105 Z = Z + V
106
107 DATA(I,1) = W/10
108 DATA(I,2) = X/10
109 DATA(I,3) = Y/10
110 DATA(I,4) = Z/10
111
112 010 WRITE(1,104) (DATA(I,J),J= 1,4,1)
113 WRITE(1,105)
114 READ(1,149) IFILE
115 CALL CREAT (IDCB,IERR,IFILE,ISIZE,ITYPE,ISECU,ICR,IDCBS)
116 JJ = 1
117 IF (IERR.LT.0) WRITE(1,111) JJ,IERR
118 CALL OPEN (IDCB,IERR,IFILE,IOPTR,ISECU,ICR,IDCBS)
119 IF (IERR.LT.0) WRITE(1,111) JJ,IERR
120 CALL WRITF (IDCB,IERR,DATA,IL)
121 JJ = 3
122 IF (IERR.LT.0) WRITE(1,111) JJ,IERR
123 CALL CLOSE (IDCB,IERR,0)
124 JJ = 4
125 IF (IERR.LT.0) WRITE(1,111) JJ,IERR
126 DATA(32,2) = 32.6149 + 34727.9 * DATA(32,2)
127 DATA(32,3) = DATA(32,3) * 10000
128 WRITE(6,601) IFILE
129 WRITE(6,602) DATA(32,1),DATA(32,2),DATA(32,3)
130 WRITE(6,603)
131 DO 020 I = 1,31,1
132 DATA(I,1) = DATA(I,1) * 10000
133 DATA(I,2) = DATA(I,2) * 10
134 DATA(I,3) = DATA(I,3) * 10000
135 DATA(I,4) = DATA(I,4) * 10000
136 CDATA(I) = (DATA(I,4) + DATA(I,2)) / DATA(I,1)
137 020 WRITE(6,604) I,DATA(I,3),DATA(I,4),DATA(I,2),DATA(I,1),CDATA(I)
138
139 CALL CLEAR (7,1)
140 CALL LDEF (7)
141 CALL PLOTN (IGCB,2,1,13)
142 CALL SEAR (IGCB,1,5)
143 CALL VIEWP (IGCB,30,110,20,70,0)
144 CALL WINDW (IGCB,-90,90,-1.0,1.0)
145 CALL FXD (IGCB,1)
146 WRITE(1,106)
147 READ(1,149) IDUM
148 IF (IDUM.EQ.2H) CALL LGRID (IGCB,-5,0.5,0.0,0.0,4.0,1.0,1.0)
149 CALL MOVE (IGCB,DATA(1,3),CDATA(1))
150 DO 040 I=1,31,1
151 CALL DRAW (IGCB,DATA(1,3),CDATA(I))
152 CALL VIEWP (IGCB,0,150,0,100)
153 CALL WINDW (IGCB,0,150,0,100)
154 CALL MOVE (IGCB,22,15)
155 CALL CPLOT(IGCB,-8,0,0)
156 CALL LABEL(IGCB)
157 WRITE(13,130) DATA(32,1),DATA(32,3)
158 CALL MOVE (IGCB,22,10)

```

Figure C-2. Listing of Calibration Data Acquisition Program &YAW.
(Continued on next page.)

```

0159 CALL CPlot (IGCB,-8.,0.,0.)
0160 CALL LABEL (IGCB)
0161 WRITE (13,1302) DATA(32,2),IFILE
0162 CALL MOVE (IGCB,18.0,20.)
0163 CALL CPlot (IGCB,-8.4,0.8)
0164 CALL LDIR (IGCB,-1.5)
0165 CALL LABEL (IGCB)
0166 WRITE (13,1303)
0167 WRITE (1,107)
0168 READ (1,149) IDUM
0169 IF (IDUM.EQ.2HYES) GOTO 1
0170 STOP 7777
0171 END
0172 REAL FUNCTION SCANR (LU,ICHAN,K)
0173 .....
0174 .....
0175 ..... Close relay ICHAN on scanner LU and read the instrument
0176 ..... indicated by K.
0177 ..... Author: Robert N. Geopfert
0178 ..... Date: February 31, 1979
0179 ..... Detailed program description is available in TXCO log; the
0180 ..... variables are:
0181 ..... LU ... LU# of desired scanner (8 or 15).
0182 ..... ICHAN ... Scanner channel (integer).
0183 ..... IC ... Scanner channel (ASCII).
0184 ..... K ... Instrument code (DVM = 1 / Counter = 2).
0185 .....
0186 .....
0187 ..... * Closes scanner and reads DVM, counter.
0188 .....
0189 101 FORMAT (A2)
0190 801 FORMAT ("C")
0191 1001 FORMAT ("T373")
0192 1201 FORMAT ("T")
0193 1501 FORMAT ("C")
0194 .....
0195 WRITE (8,801)
0196 WRITE (15,1501)
0197 IC = ICON(ICHAN,0)
0198 WRITE (LU,101) IC
0199 GO TO (01,02) K
0200 .....
0201 01 CALL TRIGR (10)
0202 READ (10,*) DUM
0203 CALL TRIGR (10)
0204 READ (10,*) SCANR
0205 GO TO 03
0206 .....
0207 02 WRITE (12,1201)
0208 READ (12,*) SCANR
0209 .....
0210 03 WRITE (LU,801)
0211 RETURN
0212 END
0213 INTEGER FUNCTION ICON(I,N)
0214 IC=I-N
0215 IF (IC.LT.10) GO TO 100
0216 CALL CODE
0217 WRITE (ICON,60) IC
0218 60 FORMAT (I2)
0219 RETURN
0220 100 ICON=IC+30060B
0221 RETURN
0222 END

```

Figure C-2. Listing of Calibration Data Acquisition Program &YAW.

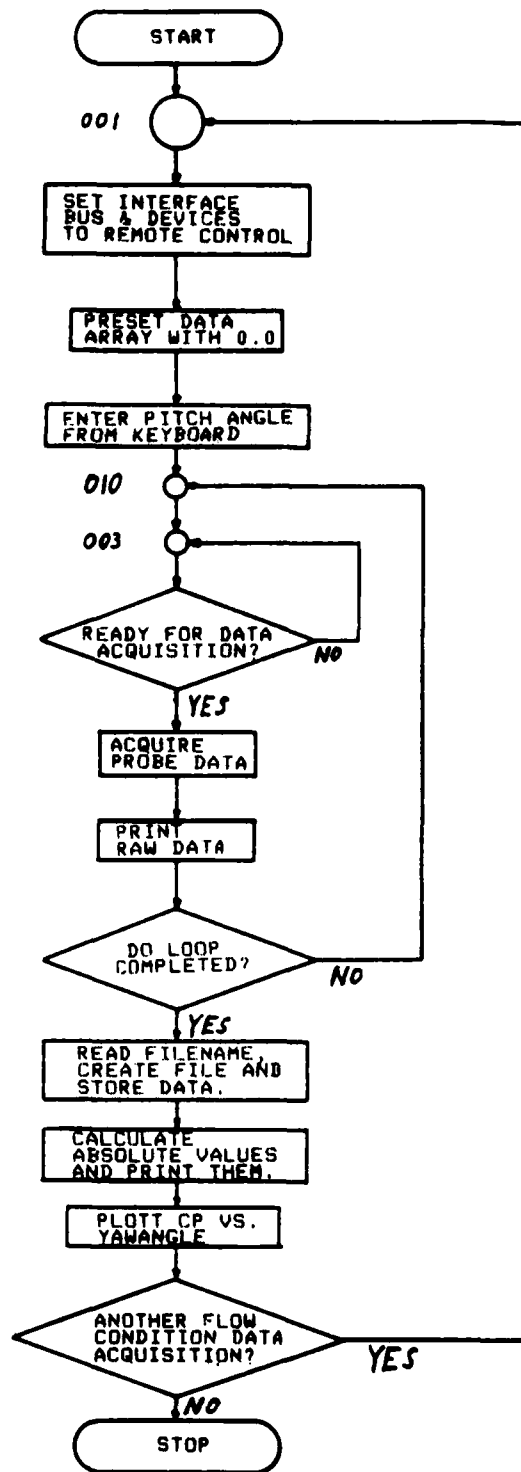

Figure C-3. Flow Chart of Data Acquisition Program & KALIB

*ALIB T=00004 IS ON CR00026 USING 00042 BLKS R=0000

```

001 FTN4,L
002 PROGRAM KALIB
003 REAL DATA(2,320),CDATA(300)
004 DIMENSION YLCLB(192),IDCS(144),IFILE(3),ISIZE(2)
005 DATA IDCSR /144/
006 DATA ISECU /8/
007 DATA ICR /27/
008 DATA IYPE /1/
009 DATA ISIZE /10,128/
010 DATA IL /1200/
011
012 C
013
014 PROGRAM TO ACQUIRE DATA FOR THE CALIBRATION OF A KULITE PROBE.
015 C
016
017 101 FORMAT(' READ PITCH ANGLE FROM TERMINAL:')
018 102 FORMAT(' WHEN YOU ARE READY FOR THE MEASUREMENT, HIT CR (")
019 103 FORMAT(' FIRST RANGE COMPLETED')
020 104 FORMAT(' WHEN YOU ARE READY TO MOVE THE PROBE BACKWARDS,KEY CR!")
021 105 FORMAT(' ENTER THE FILE NAME YOU WANT THE RAW DATA TO BE STORED IN
022 ' ')
023 106 FORMAT(' IF YOU NEED A COMPLETE NEW FRAME, KEY YE (") ANY OTHER K
024 KEY IF NOT!")
025 107 FORMAT(' IF YOU WANT ANOTHER SET OF DATA FOR A DIFFERENT PITCH ANGL
026 BE KEY YES (") ANYTHING ELSE, IF NOT!")
027 149 FORMAT(' (3A2)')
028 601 FORMAT(' RAW DATA ARE STORED IN FILE : "1X,3A2,15X" PITCH = "I4/")
029 602 FORMAT(' TUNNEL TEMP. DEG. F TUNNEL PRESS. INCHES H2O " K R
030 REF PRESS. INCHES H2O " P BARO INCHES HG")
031 603 FORMAT(' (47X,F19.7),5X"BEFORE READINGS"/)
032 604 FORMAT(' (47X,F19.7),5X"BETWEEN READINGS"/)
033 605 FORMAT(' (47X,F19.7),5X"AFTER READINGS"/)
034 606 FORMAT(' (47X,F19.7),5X"AVERAGE VALUES"/)
035 607 FORMAT(' @ YAWANG KULITEOUT CP @ YAWANG KULITEOUT CP @
036 YAWANG KULITEOUT CP @ YAWANG KULITEOUT CP @ YAWANG KULIT
037 #EDUT CP")
038 608 FORMAT(' (3,1X,F6.3,2X,F8.5,1X,F5.3,4(I4,1X,F6.3,2X,F8.5,1X,F5.3))
039 609 FORMAT(' (H1)')
040 801 FORMAT(' (CA")
041 1001 FORMAT(' (F1R7M3A1H0T3")
042 1002 FORMAT(' (F1R7M3A0H0T3")
043 1111 FORMAT(' @ = "15" IERR = "15,F12.4)
044 1301 FORMAT(' B-PROBE PITCH = "I4,1X" P BARO = "F7.3,1X" FILE = "3A2)
045 1302 FORMAT(' TUNNEL TEMPERATURE = "F7.3" TUNNEL PRESS. = "F7.3)
046 1303 FORMAT(' KULITE OUTPUT (INCHES H2O)")
047 1501 FORMAT(' (CA")
048
049
050
051
052
053
054
055
056
057
058
059
060
061
062
063
064
065
066
067
068
069
070
071
072
073
074
075
076
077
078

```

DATA LOCATION IN THE DATA FILE :

LOCATION IN FILE :	CONTAINS :
FOR I = 1 TO 300 DATA(1,I)	YAW POSITION
FOR I = 1 TO 300 DATA(2,I)	KULITE PRESS. OUTPUT

LOCATION IN FILE:	CONTAINS:	READ FROM:
DATA(1,301)	T total tunnel	Ch# 6 Scannr.# 2
DATA(2,301)	P total tunnel	Ch#20 Scannr.# 2
DATA(1,302)	K ref. press.	Ch#21 Scannr.# 2
DATA(2,302)	Barom. press.	Ch#25 Scannr.# 1
DATA(1,303)	T total tunnel	Ch# 6 Scannr.# 2
DATA(2,303)	P total tunnel	Ch#20 Scannr.# 2
DATA(1,304)	K ref. press.	Ch#21 Scannr.# 2
DATA(2,304)	Barom. press.	Ch#25 Scannr.# 1
DATA(1,305)	T total tunnel	Ch# 6 Scannr.# 2
DATA(2,305)	P total tunnel	Ch#20 Scannr.# 2
DATA(1,306)	K ref. press.	Ch#21 Scannr.# 2
DATA(2,306)	Barom. press.	Ch#25 Scannr.# 1
DATA(1,318)	T total tunnel	O v e r a g e
DATA(2,318)	P total tunnel	F a i l u r e
DATA(1,319)	K ref. press.	F r e e t h r e e
DATA(2,319)	Barom. press.	r e a d i n g s a b o v e
DATA(1,320)	Pitch angle	Terminal

Figure C-4. Listing of Calibration Data Acquisition Program &KALB.
(Continued on next page.)

```

079 C .....
080 .....
081 .....
082 001 CALL ABRT(7,2)
083 CALL RMOTE(8)
084 CALL RMOTE(10)
085 CALL RMOTE(15)
086
087 WRITE (8,801)
088 WRITE (10,1001)
089 WRITE (15,1501)
090 .....
091 C/C/C .....
092 .....
093 .....
094 .....
095 .....
096 .....
097 .....
098 .....
099 .....
100 DO 002 I = 1,320,1
101 DATA(1,I) = 0.0
102 DATA(2,I) = 0.0
103 002 WRITE(1,101)
104 READ (1,8) DATA(1,320)
105 DATA(1,301) = SCNR(15,06,01)
106 DATA(2,301) = SCNR(15,20,01)
107 DATA(1,302) = SCNR(15,21,01)
108 DATA(2,302) = SCNR(08,25,01)
109 WRITE(10,1002)
110 005 WRITE(1,102)
111 READ (1,149) IDUM
112 IF ( IDUM .NE. 2M ) GOTO 005
113 DO 010 I = 1,150,1
114 DATA(1,I) = SCNR(15,22,01)
115 DATA(2,I) = SCNR(15,23,01)
116 DATA(1,303) = SCNR(15,24,01)
117 DATA(2,303) = SCNR(15,20,01)
118 DATA(1,304) = SCNR(15,21,01)
119 DATA(2,304) = SCNR(08,25,01)
120 WRITE(1,103)
121 015 WRITE(1,104)
122 READ(1,149) IDUM
123 IF ( IDUM .NE. 2M ) GOTO 015
124 DO 018 I = 1,300,1
125 DATA(1,I) = SCNR(15,22,01)
126 DATA(2,I) = SCNR(15,23,01)
127 DATA(1,305) = SCNR(15,24,01)
128 DATA(2,305) = SCNR(15,20,01)
129 DATA(1,306) = SCNR(15,21,01)
130 DATA(2,306) = SCNR(08,25,01)
131 CALL CLEAR(7,1)
132 CALL LOCL(7)
133 DO 019 I = 1,319,1
134 DATA(1,I) = DATA(1,I) * 10000
135 DATA(2,I) = DATA(2,I) * 10000
136 DO 020 I = 301,305,2
137 DATA(1,I) = 32.6149 + 3.47279 * DATA(1,I)
138 DATA(2,I) = DATA(2,I) * 10
139 DATA(1,318) = (DATA(1,301)+DATA(1,303)+DATA(1,305))/3
140 DATA(2,318) = (DATA(2,301)+DATA(2,303)+DATA(2,305))/3
141 DATA(1,319) = (DATA(1,302)+DATA(1,304)+DATA(1,306))/3
142 DATA(2,319) = (DATA(2,302)+DATA(2,304)+DATA(2,306))/3
143 DO 021 I = 1,300,1
144 CDATA(I) = (DATA(2,I)+DATA(1,319)) /DATA(2,318)
145 WRITE(1,105)
146 READ (1,149) IFILE
147 CALL CREAT (IDCB,IERR,IFILE,ISIZE,ITYPE,ISECU,ICR,IDCBS)
148 JJ = 1
149 IF (IERR .LT. 0) WRITE(1,1111) JJ,IERR
150 CALL OPEN (IDCB,IERR,IFILE,IOPTR,ISECU,ICR,IDCBS)
151 JJ = 2
152 IF (IERR .LT. 0) WRITE(1,1111) JJ,IERR
153 CALL WRITF (IDCB,IERR,DATA,IL)
154 JJ = 3
155 IF (IERR .LT. 0) WRITE(1,1111) JJ,IERR
156 CALL CLOSE (IDCB,IERR,0)
157 JJ = 4
158 IF (IERR .LT. 0) WRITE (1,1111) JJ,IERR
159 WRITE(6,601) IFILE,DATA(1,320)
160 WRITE(6,602)
161 WRITE (6,603) DATA(1,301),DATA(2,301),DATA(1,302),DATA(2,302)
162 WRITE (6,604) DATA(1,303),DATA(2,303),DATA(1,304),DATA(2,304)

```

Figure C-4. Listing of Calibration Data Acquisition Program &KALIB.
(Continued on next page.)

```

157 WRITE (6,605) DATA(1,305),DATA(2,305),DATA(1,306),DATA(2,306)
160 WRITE (6,606) DATA(1,318),DATA(2,318),DATA(1,319),DATA(2,319)
161 WRITE(6,607)
162 DO 030 I = 1, 60, 1
163 J = I + 60
164 II = J + 60
165 JJ = II + 60
166 III = JJ + 60
167 030 WRITE(6,608) I, DATA(1, I), DATA(2, I), CDATA(I), J, DATA(1, J), DATA(2, J), C
168 *DATA(J), II, DATA(1, II), DATA(2, II), CDATA(II), JJ, DATA(1, JJ), DATA(2, JJ)
169 *), CDATA(JJ), III, DATA(1, III), DATA(2, III), CDATA(III)
170
171 WRITE(6,609)
172 CALL PLOTR (IGCB, 2, 1, 13)
173 CALL SETAR (IGCB, 1, 5)
174 CALL VIEWP (IGCB, 30., 110., 20., 68.0)
175 CALL WINDW (IGCB, -80., 80., -160.00, 160.0)
176 CALL FXD (IGCB, 1)
177 WRITE(1,106)
178 READ (1,149) IDUM
179 IF (IDUM.EQ. 2HIE) CALL LGRID (IGCB, -5., 10., 0.0, 0.0, 4.0, 2.0, 1.0)
180 CALL MOVE (IGCB, DATA(1, I), DATA(2, I))
181 DO 040 I = 1, 308, 1
182 040 CALL DRAW (IGCB, DATA(1, I), DATA(2, I))
183 IF (IDUM.NE. 2HIE) GOTO 050
184 CALL VIEWP (IGCB, 0., 150., 0., 100.)
185 CALL WINDW (IGCB, 0., 150., 0., 100.)
186 CALL MOVE (IGCB, 22., 15.)
187 CALL CPlot(IGCB, 8., 0., 0)
188 CALL LABEL (IGCB)
189 WRITE(13,1301) DATA(1,320), DATA(2,319), IFILE
190 CALL MOVE (IGCB, 22., 10.)
191 CALL CPlot (IGCB, -8., 0., 0.)
192 CALL LABEL (IGCB)
193 WRITE (13,1302) DATA(1,318), DATA(2,318)
194 CALL MOVE (IGCB, 18.0, 20.)
195 CALL CPlot (IGCB, -8., 0., 0.)
196 CALL LDIR (IGCB, 1, 57)
197 CALL LABEL (IGCB)
198 WRITE (13,1303)
199 050 CONTINUE
200 WRITE(1,107)
201 READ(1,149) IDUM
202 IF (IDUM.EQ. 2HIE) GOTO 1
203 STOP 7777
204 END
205 REAL FUNCTION SCANR (LU, ICHAN, K)
206
207 .....
208 ..... Close relay ICHAN on scanner LU and read the instrument
209 ..... indicated by K.
210 ..... Author: Robert N. Geopfarth
211 ..... Date: February 31, 1979
212 ..... Detailed program description is available in TXCO log; the
213 ..... variables are:
214 ..... LU ..... LU# of desired scanner (8 or 15).
215 ..... ICHAN ..... Scanner channel (integer).
216 ..... IC ..... Scanner channel (ASCII).
217 ..... K ..... Instrument code (DVM = 1 / Counter = 2).
218 .....
219 .....
220 .....
221 ..... Closes scanner and reads DVM, counter.
222 101 FORMAT (A3)
223 801 FORMAT ("C")
224 1001 FORMAT ("T3T3")
225 1201 FORMAT ("T")
226 1501 FORMAT ("C")
227
228 WRITE (8, 801)
229 WRITE (19, 801)
230 IC = ICON/ICHAN, 0)
231 WRITE (LU, 101) IC
232 GO TO (01, 02) K
233
234 01 CALL TRIGR (10)
235 READ (10, *) DUM
236 CALL TRIGR (10)
237 READ (10, *) SCANR
238 GO TO 03

```

Figure C-4. Listing of Calibration Data Acquisition Program &KALIB.
(Continued on next page.)

```

0239      02 WRITE (12,1201)
0240      READ (12, * ) SCANN
0241
0242      03 WRITE (11, 801)
0243      RETURN
0244      END
0245      INTEGER FUNCTION ICON(I,N)
0246      IC=I*N
0247      IF(IC.LT.10) GO TO 100
0248      CALL CODE
0249      WRITE(ICON,60)IC
0250      60  FORMAT(I2)
0251      RETURN
0252      100  ICON=IC+300600
0253      RETURN
0254      END

```

Figure C-4. Listing of Calibration Data Acquisition Program &KALIB.

APPENDIX D
DATA REDUCTION PROGRAMS &REST8 AND &REST9

The programs &REST8 and &REST9 are in principal the same and follow the same logic. They are used to approximate the Mach number--or X --and the pitch angle, ϕ , as functions of the two independent variables β and γ (see 4.5). The software used to work out the approximations is described explicitly in Ref. 6. Basis for the approximation is the data as shown in Table V. This data is stored as a 10 by 54 array in a data file ABNEW2 on cartridge 26. The data is read into a 10 by 54 array from file ABNEW2 by both programs. Since the approximation itself is carried out in external subroutines, the necessary variables are contained in a common block. &REST8 thus contains β (BETA), γ (GAMMA) and X (XVEL) while &REST9 contains β (BETA), γ (GAMMA) and PHI (pitch angle in radians). As approximations of different order are possible for both variables β and γ , the orders of the approximations are increased from one to six in a DO-loop for both variables, resulting in a total of 36 combinations.

For all combinations the set of coefficients is printed out and also an array (6,9) for all errors (see 4.5) resulting from this particular approximation. When the whole DO-loop is worked out, the operator has to decide what order of approximation he wants to use for the application of the

probes. In general lower order polynomials should be preferred against higher ones, although the latter promise the smaller overall error. The criterion for the decision should be the error distribution within a range of Mach number and pitch angle which will be the one of the most common application.

Once this decision has been made, the operator inputs the desired orders of polynomials. The corresponding coefficients are then recalculated and the operator is asked for a file name under which he wants to have these coefficients stored in a 7 by 7 array.

As programs &REST8 and &REST9 are in principal identical, only one flow chart (Fig. D-1) is given, and a listing of program &REST9 is given in (Fig. D-2).

Labeled common blocks:

<u>Common block identifier</u>	<u>Variable</u>
MATRX	A, B
SUMME	BETA, GAMMA, XVEL (or PHI)

<u>Variables</u>	<u>Type</u>	<u>Description</u>
A(49,49)	Real	System matrix used for the 3-D approximation of XVEL (or PHI) as function of BETA and GAMMA (see Ref. 6)
B(49)	Real	Right hand side vector of 3-D approximation (see Ref. 6)
BETA(16,16)	Real	Beta--pressure coefficient
COEFF(7,7)	Real	Approximation coefficients array

<u>Variables</u>	<u>Type</u>	<u>Description</u>
D(10,54)	Real	Calibration data array
GAMMA	Real	Gamma--pressure coefficient
ICR	Integer	Cartridge reference number
IDCB(144)	Integer	Data control block
IFILE(3)	Integer	Array containing file name
ISECU	Integer	Security code
ISIZE(2)	Integer	Array to specify file dimensions (1st word for number of records, 2nd for record length)
ITYPE	Integer	Type of data file
NMACH	Real	Number of different Mach number settings during the calibration
NPITCH	Real	Number of different pitch angle settings during the calibration
PHI(16,16)	Real	Array containing the actual pitch angle settings during the calibration
PI	Real	3.14593
R(16)	Real	Array containing the individual errors between calibration data and calculated values
SUM	Real	Calculated value of XVEL or PHI (depending on program)
XVEL(16,16)	Real	Array containing the actual Mach number (X) settings during the calibration

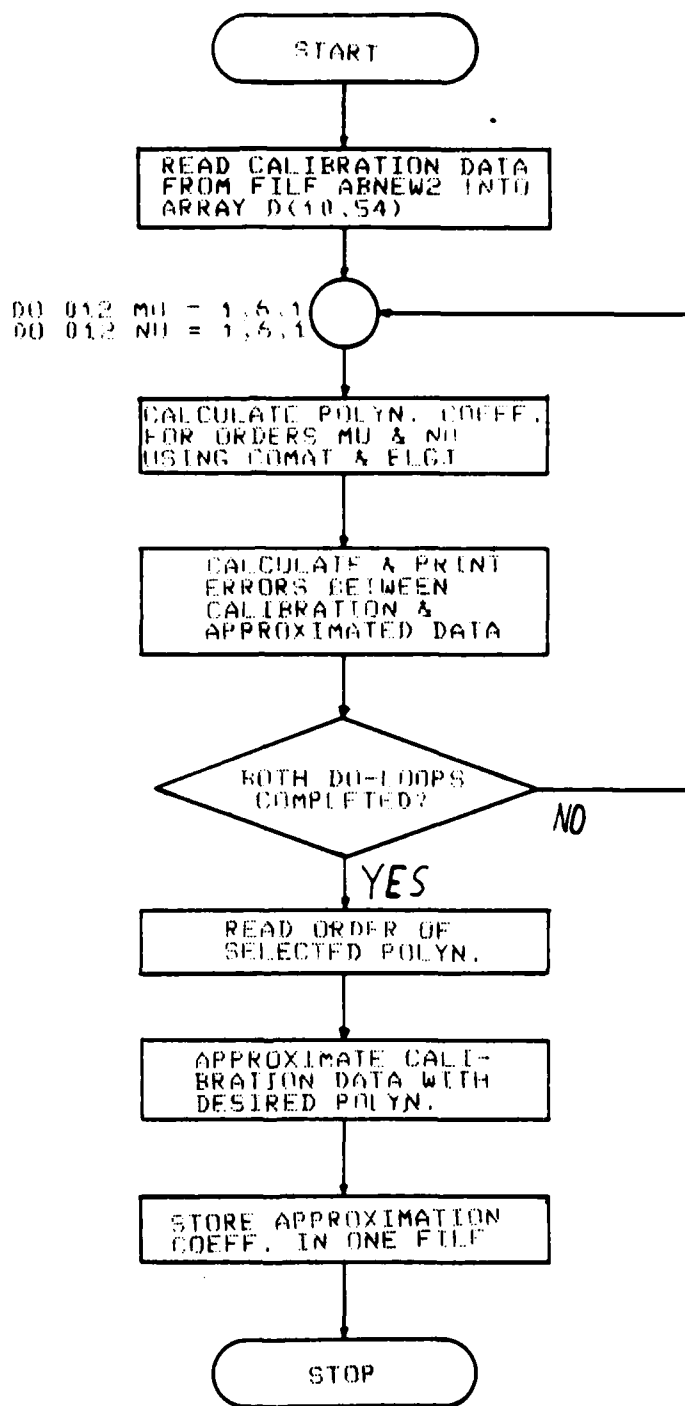

Figure D-1. Flow Chart of Data Reduction Program & REST 8/9

&REST9 T=00004 IS ON CR00026 USING 00024 BLKS R=0000

```
0001 FTN4,L
0002 PROGRAM REST9 (3,99)
0003 .....
0004 .....
0005 .....
0006 .....
0007 .....
0008 .....
0009 .....
0010 .....
0011 .....
0012 .....
0013 .....
0014 .....
0015 .....
0016 .....
0017 .....
0018 .....
0019 .....
0020 .....
0021 .....
0022 .....
0023 .....
0024 .....
0025 .....
0026 .....
0027 .....
0028 .....
0029 .....
0030 .....
0031 .....
0032 .....
0033 .....
0034 .....
0035 .....
0036 .....
0037 .....
0038 .....
0039 .....
0040 .....
0041 .....
0042 .....
0043 .....
0044 .....
0045 .....
0046 .....
0047 .....
0048 .....
0049 .....
0050 .....
0051 .....
0052 .....
0053 .....
0054 .....
0055 .....
0056 .....
0057 .....
0058 .....
0059 .....
0060 .....
0061 .....
0062 .....
0063 .....
0064 .....
0065 .....
0066 .....
0067 .....
0068 .....
0069 .....
0070 .....
0071 .....
0072 .....
0073 .....
0074 .....
0075 .....
0076 .....
0077 .....
0078 .....
0079 .....
0080 .....
0081 .....
0082 .....
0083 .....
0084 .....
0085 .....
0086 .....
0087 .....
0088 .....
0089 .....
0090 .....
0091 .....
0092 .....
0093 .....
0094 .....
0095 .....
0096 .....
0097 .....
0098 .....
0099 .....
0100 .....

COMMON / MATRIX / A B
COMMON / SUMME / BETA GAMMA PHI
REAL A(49,49), B(49), COEFF(7,7), D(10,54)
INTEGER IDC8(144), IFILE(3), ISIZE(2)
REAL BETA(16,16), GAMMA(16,16), PHI(16,16)
DATA R(16)
DATA PI(16)
DATA IFILE /2HAB,2HNE,2HW2/
DATA ISEC8 /8/
DATA ICR /26/
DATA ITYPE /1/
DATA ISIZE /3,128/
DATA IDC8S /144/
101 FORMAT (' SELECT SET OF COEFFICIENTS FOR BEST RESULTS -"/" ENTER M
ORDER AND ORDER NOW :')
149 FORMAT('"/'(3A2))
601 FORMAT ('"/' COEFFICIENTS FOR THE CALIBRATION SURFACE STORED IN FI
#LE : "3A2"/)
602 FORMAT ('(3X,10(11X,12))')
603 FORMAT ('(1X,12,7(2X,F11.6))')
604 FORMAT ('"/' ERRORS AT EACH POINT (DEGREES)"/)
605 FORMAT ('(3X,16(6X,12))')
606 FORMAT ('(1X,12,16(1X,F7.3)/7(1X,16(1X,F7.3)/)')
1111 FORMAT (' STATEMENT 0 "14" - ERROR 0 "14" - ENCOUNTERED "/)
LI = LOG(LI)

READ DATA FILE ARNEW2 FROM CARTRIDGE 26 INTO ARRAY D:10 "4

CALL OPEN (IDC8, IERR, IFILE, ICPIN, ISEC8, ICR, IDC8S)
JJ = 1
IF ( IERR .LT. 0 ) WRITE (LI,1111) JJ, IERR
CALL READF (IDC8, IERR, D, 1080, LEN, 1)
JJ = 2
IF ( IERR .LT. 0 ) WRITE (LI,1111) JJ, IERR
CALL CLOSE (IDC8, IERR, 3)
JJ = 3
IF ( IERR .LT. 0 ) WRITE (LI,1111) JJ, IERR

IJ = 0
DO 001 I = 1, 6, 1
DO 001 J = 1, 9, 1
IJ = IJ + 1
IF (J .EQ. 5) D(4, IJ) = D(4, IJ) + 1.00001
PHI (I, J) = D(4, IJ) * PI * 180.0
BETA (I, J) = D(8, IJ)
001 GAMMA(I, J) = D(9, IJ)

NMACH = 6
NPITCH = 9

002 CONTINUE

CALCULATE CALIBRATION SURFACE COEFFICIENTS
```

Figure D-2. Listing of Reduced Data Approximation Program &REST9. (Continued on next page.)

```

0079 C .....
0080 IJI = 0
0081 DO 011 MU = 1,6,1
0082 DO 011 NU = 1,6,1
0083 MORDER = MU
0084 NORDER = NU
0085 003 CONTINUE
0086 DO 004 I = 1,7,1
0087 DO 004 J = 1,7,1
0088 004 COEFF(I,J) = 0.0
0089 M = MORDER+1
0090 N = NORDER+1
0091 CALL COMAT (A,B,M,N,NMACH,NPITCH)
0092 NEQUS = ASN
0093 CALL ELGJ (NEQUS)
0094 I = 0
0095 DO 005 I = 1,M,1
0096 DO 005 J = 1,N,1
0097 I1 = I+1
0098 005 COEFF(I,J) = B(I1)
0099 IF ( IJI .NE. 1 ) GOTO 006
0100 IFILE(1) = 4MI
0101 IFILE(2) = 54ST
0102 IFILE(3) = 24FI
0103 CALL CREAT (IDCB,IERR,IFILE,ISIZE,ITYPE,ISECU,ICR,IDCBS)
0104 JJ = 4
0105 IF ( IERR .GT. 0 ) WRITE (LI,1111) JJ,IERR
0106 CALL OPEN (IDCB,IERR,IFILE,IOPIN,ISECU,ICR,IDCBS)
0107 JJ = 5
0108 IF ( IERR .LT. 0 ) WRITE (LI,1111) JJ,IERR
0109 CALL WRITF (IDCB,IERR,COEFF,98)
0110 JJ = 6
0111 IF ( IERR .LT. 0 ) WRITE (LI,1111) JJ,IERR
0112 CALL CLOSE (IDCB,IERR,0)
0113 JJ = 7
0114 IF ( IERR .LT. 0 ) WRITE (LI,1111) JJ,IERR
0115 WRITE (6,601) IFILE
0116 006 CONTINUE
0117 WRITE (6,602) (J,J=1,N,1)
0118 DO 007 I=1,M,1
0119 007 WRITE (6,603) I,(COEFF(I,J),J=1,N,1)
0120 WRITE (6,602) (J,J=1,N,1)
0121
0122 CCCCC
0123 : CALCULATE ERRORS FOR ALL MACHNUMBER PITCHANGLE COMBINATIONS. :
0124 :
0125 CCCCC
0126
0127 WRITE (6,604)
0128 WRITE (6,605) (J,J=1,NPITCH,1)
0129 DO 010 I = 1,NMACH,1
0130 DO 009 J = 1,NPITCH,1
0131 SUM = 0.
0132 DO 008 I1 = 1,M,1
0133 DO 008 J1 = 1,N,1
0134 008 SUM=SUM+(COEFF(I1,J1)*GAMMA(I,J)**(J1-1))*BETA (I,J)**(I1-1)
0135 009 R(J) = (PHI(I,J) - SUM) * 180.0 / PI
0136 010 WRITE (6,606) I,(R(J),J=1,NPITCH,1)
0137 WRITE (6,605) (J,J=1,NPITCH,1)
0138
0139 IF (IJI .EQ. 1 ) GOTO 012
0140
0141
0142 011 CONTINUE
0143 WRITE (LI,101)
0144 READ (LI,*) MORDER,NORDER
0145 IJI = 1
0146 GOTO 003
0147 012 STOP 7777
0148 END

```

Figure D-2. Listing of Reduced Data Approximation Program &REST9.

APPENDIX E
DATA EVALUATION PROGRAM &EVALU

As described in 5.1, program &EVALU simulates a case in which calibration data is treated as actual test data--as far as possible. From this data flow quantities of Mach number and pitch angle are derived using the whole data reduction method, and compared with the known actual values.

The program is set up to perform this comparison for all given Mach number/pitch angle combinations. However, since the process is rather extensive and time-consuming, the procedure is actually only worked out for a limited range of calibration settings.

First of all the program reads the sets of coefficients for the Mach number and pitch angle approximations (as generated in &REST8 and &REST9) into two arrays. In a loop corresponding calibration data of the "A" and "B" probes for one Mach number/pitch angle combination is read at a time. This data is read into two data arrays (ADATA(2,320) and BDATA(2,320)). For nine defined yaw angles ($\pm 65^\circ$, $\pm 45^\circ$, $\pm 30^\circ$, $\pm 15^\circ$, 0°) the program searches for given yaw angles which are closest to the defined ones and averages four yaw angles bigger and four smaller than the one found as well as it averages the corresponding pressure values. This results in nine single pairs of PA values and yaw angles. The

B probe "data acquisition" is handled differently. For a range of yaw angle smaller than the whole calibration range the output of the B probe p_B is approximated with a sixth order polynomial as a function of yaw angle. For nine specific values of yaw ($\pm 30^\circ$, $\pm 22.5^\circ$, $\pm 15^\circ$, $\pm 7.5^\circ$, 0°) corresponding pressure values p_B are calculated using the derived polynomial.

These data arrays PA(9)/YAWA(9) and PB(9)/YAWB(9) are equivalent to the data acquired in a test. They are again approximated and the pressure values PAMAX, PSA and PBMAX are calculated. The data reduction procedure as outlined in 4.5 is applied to these values and the Mach number (or X) and pitch angle are derived. Since the yaw angle is always adjusted to zero when aligned with the flow in the freejet, the yaw angle should always turn out to be zero. However, the program offers the possibility to artificially superimpose a different yaw angle in that the given relationships $p_A = P_A(\alpha)$ and $p_B = P_B(\alpha)$ are shifted to $p_A = P_A(\alpha + \Delta\alpha)$ and $p_B = P_B(\alpha + \Delta\alpha)$, where $\Delta\alpha$ is the "artificial" yaw angle. The quality of the flow quantity calculations is expressed in errors of Mach number, pitch angle and yaw angle as described in 5.1. The necessary error values are printed out and the loop is continued. Figure E-1 gives a flow chart of the program while Fig. E-2 contains a listing.

Labeled Common Block:

Common block identifier:

DTA2

Variable:

X1, Y

<u>Variable</u>	<u>Type</u>	<u>Description</u>
AAO	Real	Flow yaw angle derived from A probe
ABO	Real	Flow yaw angle derived from B probe
ADATA(2,320)	Real	Array to contain the A probe data
AFILE(3)	Integer	Array to contain the file name for A probe data
ASL	Real	Left hand side yaw angle of A probe output
ASR	Real	Right hand side yaw angle of A probe output
BDATA(2,320)	Real	Array to contain the B probe data
BFILE(3)	Integer	Array to contain the file name for B probe data
COEF(7)	Real	Array to contain coefficients from 2-D approximations
COEUX(7,7)	Real	Array containing the coefficients of the 3-D approximation for the velocity
COEUP(7,7)	Real	Array containing the coefficients of the 3-D approximation for the pitch angle
CPAMAX	Real	Maximum pressure coefficient A probe
CPBMAX	Real	Maximum pressure coefficient B probe
DP	Real	Pressure difference for two pressure values corresponding to two yaw angles which are separated by DX
DPX	Real	First derivative of the function $p_A(\alpha) - p_A(\alpha - \Delta\alpha)$
DX	Real	Given spread in yaw angle between PSAL and PSAR

<u>Variable</u>	<u>Type</u>	<u>Description</u>
ERPHI	Real	Error between measured and calculated pitch angle
ERXVEL	Real	Error between measured and calculated Mach number (Xvel rsp.)
ERYAW	Real	Error between measured and calculated yaw angle
GAMMA	Real	Pressure coefficient
ICR	Integer	Cartridge reference number
IDCB(144)	Integer	Data control block
IFILE(3)	Integer	Array containing file name
IL	Integer	Total number of words read from data file (two words for one value)
ISECU	Integer	Security code
ISIZE(2)	Integer	Array to specify file dimensions
ITYPE	Integer	Type of data file
ICLR(3)	Integer	Command to clear line above cursor
NOLF	Integer	No line feed command
NOCR	Integer	No carriage return command
PA(9)	Real	Array for A probe pressure values
PAMAX	Real	Maximum pressure of A probe
PB(9)	Real	Array for B probe pressure values
PBMAX	Real	Maximum pressure of B probe
PHI	Real	Pitch angle (calculated)
PHIME	Real	Pitch angle (measured)
PSA	Real	Static pressure equivalent of A probe
PSAL	Real	Pressure reading of A probe for a yaw angle 63° to the left of the flow aligned yaw angle

<u>Variable</u>	<u>Type</u>	<u>Description</u>
PSAR	Real	Pressure reading of A probe for a yaw angle 63° to the right of the flow aligned yaw angle
PSTAT	Real	Static pressure
PTOTAL	Real	Total pressure
P1-P8	Real	A probe pressure values in the vicinity of a given yaw angle giving the basis to find an average pressure value for the corresponding yaw angle
XVEL	Real	Mach number equivalent dimensionless speed
XVELME	Real	Measured XVEL
X0	Real	Starting value for the iteration to find PSAL and PSAR
X1(256)	Real	Data array for 2-D approximations
Y(256)	Real	Data array for 2-D approximations
YAWA(9)	Real	Array containing A probe yaw angles
YAWB(9)	Real	Array containing B probe yaw angles
YAWOFF	Real	Superimposed yaw angle offset to simulate yaw angles different from 0° .
Y1-Y8	Real	A probe yaw angles in the vicinity of a given yaw angle equivalent to P1-P8.

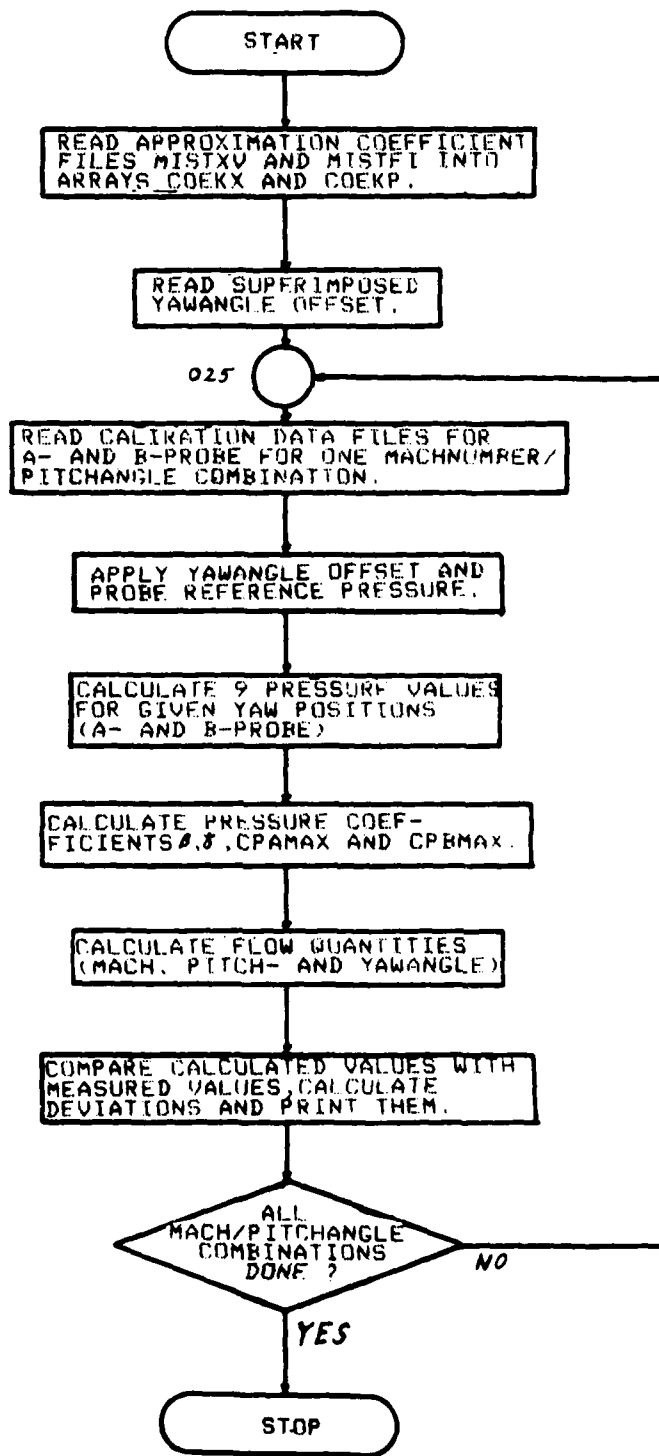

Figure E-1. Flow Chart of Data Evaluation Program &EVALU.

SEVALU T=00004 IS ON CR00026 USING 00051 BLKS R=0000

```
0001 FTN4,L
0002 PROGRAM EVALU (3,99)
0003
0004 .....
0005 THIS IS PROGRAM E V A L U (ate) !
0006 .....
0007 IT CAN TREAT THE RAW DATA FROM THE A- AND B-PROBE CALI-
0008 BRATION LIKE ACTUAL TEST DATA !
0009 .....
0010 .....
0011 COMMON / DTA2 / X1 Y
0012 INTEGER IDCR(144) ,IFILE(3) ,ISIZE(2) ,NOLF ,NOCR(2) ,ICLR(3)
0013 INTEGER AFILE(3) ,BFILE(3)
0014 REAL ADATA(7,320) ,BDATA(7,320) ,X1(256) ,Y(256) ,COEF(7)
0015 REAL COEKX(7,7) ,COEKP(7,7)
0016 REAL PA(9) ,PB(9) ,YAWA(9) ,YAWB(9)
0017
0018 DATA ISIZE (1) / 10/
0019 DATA ISIZE (2) / 128/
0020 DATA ITYPE / 1/
0021 DATA IDCBS / 144/
0022 DATA IL / 1280/
0023 DATA NOLF / 006517B/
0024 DATA NOCR / 000033B,044433B/
0025 DATA ICLR / 015524B,015515B,006537B/
0026 148 FORMAT ( ' DO YOU WANT AN OUTPUT OF THE CALIBRATION COEFFICIENTS?'
0027 # ' ENTER YES IF SO OR ANYTHING ELSE IF NOT' )
0028
0029 149 FORMAT ( '(3A2) )
0030 150 FORMAT ( ' ENTER FILE ( ) FOR X APPROXIMATION!' /
0031 # ' DON'T FORGET SECURITY CODE & CARTRIDGE REFERENCE NUMBER!' /
0032 # ' )' )
0033 151 FORMAT ( '3A2,1X,I2,1X,I2)
0034 152 FORMAT ( '// THE DATA READ FROM FILE "3A2" ARE' / )
0035 153 FORMAT ( ' I 7 J / 18,5113)
0036 154 FORMAT ( ' I 3 7 (1X,F11.6) )
0037 155 FORMAT ( ' ENTER FILE (SIFP ) FOR PHI APPROXIMATION!' /
0038 # ' DON'T FORGET SECURITY CODE & CARTRIDGE REFERENCE NUMBER!' /
0039 # 'SIFP )' )
0040 156 FORMAT ( ' ENTER THE OFFSET OF THE YAW ANGLE IN DEGREES !' )
0041 157 FORMAT ( ' RESULTS FROM THE A-B SYSTEM "/ 10X" CALCULATION: "15X" MEASU-
0042 REMENT: "12X" ERRORS "6X" XVEL "5X" PITCH "7X" YAW "6X" XVEL "5X" PITCH "6X" XV
0043 REL "5X" PITCH "7X" YAW "3X" YAW FROM A PROBE' / )
0044 158 FORMAT ( 'X(3A2) )
0045 159 FORMAT ( ' " R A W D A T A " / " @ A - KULITE B - KULITE "7X" YAW A
0046 # "7X" YAW B' )
0047 160 FORMAT ( 'I3,4(2X,F10.5) )
0048 161 FORMAT ( ' A-PROBE APPROXIMATION RESULTS : YAW = "3(SX,F9.2)/16X" PR
0049 #SSURE (INCH H20) = "3(3X,F11.6)/29X" CPAMAX = "F8.4/ )
0050 162 FORMAT ( ' B-PROBE APPROXIMATION RESULTS : YAW = "F5.1" PRESSURE
0051 # (INCH H20) = "F6.2/ )
0052 163 FORM ( '1X,F9.4,2(3X,F7.2),1X,F7.4,3X,F7.2,1X,F9.4,3(3X,F7.2) )
0053 601 FORMAT ( ' I / J / 112,6116)
0054 602 FORMAT ( ' I 3 7 (1X,F11.6) )
0055 603 FORMAT ( ' ARTIFICIAL YAW ANGLE OFFSET IS : "I3" DEGREES "/ )
0056 604 FORMAT ( / )
0057 1111 FORMAT ( ' STATEMENT @ = "I3" ERROR @ = "I3" ENCOUNTERED!' )
0058 LI = LOGLU (ISESSN)
0059 LO = 0
0060 WRITE (LI,148)
0061 READ (LI,149) IPRINI
0062 .....
0063 READ FILE FROM DISC INTO ARRAY COEYX(7,7)
0064 .....
0065 .....
0066 WRITE (LI,150) NOLF
0067 READ (LI,151) IFILE,ISECU,ICR
0068 WRITE (LI,149) (ICLR,11 = 1,3)
0069 CALL OPEN (IDCR,IERR,IFILE,IOPTN,ISECU,ICR,IDCRS)
0070 JJ = 1
0071 IF (IERR .LT. 0) WRITE (LI,1111) JJ,IERR
0072 CALL READF (IDCR,IERR,COEYX,98,LEN,1)
0073 JJ = JJ + 1
0074 IF (IERR .LT. 0) WRITE (LI,1111) JJ,IERR
0075 CALL CLOSE (IDCR,IERR,0)
0076 JJ = JJ + 1
0077 IF (IERR .LT. 0) WRITE (LI,1111) JJ,IERR
0078 IF (IPRINI .NE. 2HYS) GOTO 014
```

Figure E-2. Listing of Calibration Data Evaluation Program &EVALU.
(Continued on next page.)

```

0078
0080 .....
0081 ..... OUTPUT INPUT DATA.
0082 .....
0083 .....
0084 ..... WRITE (LI, 152) IFILE
0085 ..... IF ( LO .NE. 0 ) WRITE (LO, 152) IFILE
0086 ..... WRITE (LI, 153) (I1, I1=1,7)
0087 ..... IF ( LO .NE. 0 ) WRITE (LO, 601) (I1, I1=1,7)
0088 ..... DO 005 I1=1,7,1
0089 ..... IF ( LO .NE. 0 ) WRITE (LO, 602) I1, (COEKX(I1, J1), J1=1,7,1)
0090 ..... 005 WRITE (LI, 154) I1, (COEKX(I1, J1), J1=1,7,1)
0091 .....
0092 .....
0093 ..... READ FILE FROM DISC INTO ARRAY COEKP(7,7).
0094 .....
0095 .....
0096 ..... 010 CONTINUE
0097 ..... WRITE (LI, 155) NOLF
0098 ..... READ (LI, 151) IFILE, ISECU, ICR
0099 ..... WRITE (LI, 149) (ICLR, I1 = 1,3)
0100 ..... CALL OPEN (IDCB, IERR, IFILE, IOPTN, ISECU, ICR, IDCBS)
0101 ..... I1 = 4
0102 ..... IF ( IERR .LT. 0 ) WRITE (LI, 1111) JJ, IERR
0103 ..... CALL READF (IDCB, IERR, COEKP, 98, LEN, 1)
0104 ..... JJ = 5
0105 ..... IF ( IERR .LT. 0 ) WRITE (LI, 1111) JJ, IERR
0106 ..... CALL CLOSE (IDCB, IERR, 0)
0107 ..... JJ = 6
0108 ..... IF ( IERR .LT. 0 ) WRITE (LI, 1111) JJ, IERR
0109 ..... IF (IPRIN1 .NE. 2MYE) GOTO 020
0110 .....
0111 .....
0112 ..... OUTPUT INPUT DATA.
0113 .....
0114 .....
0115 ..... WRITE (LI, 152) IFILE
0116 ..... IF ( LO .NE. 0 ) WRITE (LO, 152) IFILE
0117 ..... WRITE (LI, 153) (I1, I1=1,7)
0118 ..... IF ( LO .NE. 0 ) WRITE (LO, 601) (I1, I1=1,7)
0119 ..... DO 015 I1=1,7,1
0120 ..... IF ( LO .NE. 0 ) WRITE (LO, 602) I1, (COEKP(I1, J1), J1=1,7,1)
0121 ..... 015 WRITE (LI, 154) I1, (COEKP(I1, J1), J1=1,7,1)
0122 ..... 020 CONTINUE
0123 .....
0124 .....
0125 ..... THE DATA ACQUISITION SHALL BE PERFORMED NOW !
0126 .....
0127 .....
0128 .....
0129 ..... WRITE (LI, 156)
0130 ..... READ (LI, 8) YAWOFF
0131 ..... WRITE (LO, 603) YAWOFF
0132 ..... AF1(1) = 2MA2
0133 ..... AF1(2) = 2MKP
0134 ..... BFILE(1) = 2MR2
0135 ..... IJI = 1
0136 ..... IS = 1
0137 ..... WRITE (LO, 157)
0138 ..... GOTO 135
0139 ..... 025 CONTINUE
0140 ..... WRITE (LI, 158) AF1(1)
0141 ..... WRITE (LI, 158) BFILE(1)
0142 ..... IJI = IJI + 1
0143 ..... IS = IS + 1
0144 ..... IF (AF1(1) .EQ. 2MA2 .OR. AF1(2) .EQ. 2MKN .OR. AF1(3) .EQ. 2M2S .OR.
0145 ..... *AF1(3) .EQ. 2M20) GOTO 135
0146 ..... CALL OPEN (IDCB, IERR, AF1, IOPTN, ISECU, ICR, IDCBS)
0147 ..... I1 = 7
0148 ..... IF ( IERR .LT. 0 ) WRITE (LI, 1111) JJ, IERR
0149 ..... CALL READF (IDCB, IERR, ADATA, I1, LEN, 1)
0150 ..... JJ = 8
0151 ..... IF ( IERR .LT. 0 ) WRITE (LI, 1111) JJ, IERR
0152 ..... CALL CLOSE (IDCB, IERR, 0)
0153 ..... JJ = 9
0154 ..... IF ( IERR .LT. 0 ) WRITE (LI, 1111) JJ, IERR
0155 .....
0156 ..... CALL OPEN (IDCB, IERR, BFILE, IOPTN, ISECU, ICR, IDCBS)
0157 ..... JJ = 10
0158 ..... IF ( IERR .LT. 0 ) WRITE (LI, 1111) JJ, IERR

```

Figure E-2. Listing of Calibration Data Evaluation Program &EVALU.
(Continued on next page.)

```

0150 CALL READF (IDCR,IERR,BDATA,JJ,LEN,1)
0151 J = JJ
0152 IF ( IERR .LT. 0 ) WRITE (LI,1111) JJ,IERR
0153 CALL CLOSE (IDCR,IERR,J)
0154 JJ = JJ + 1
0155 IF ( IERR .LT. 0 ) WRITE (LI,1111) JJ,IERR
0156
0157 DO 030 I = 1,300,1
0158 ADATA (1,I) = ADATA (1,I) + YAWOFF
0159 BDATA (1,I) = BDATA (1,I) + YAWOFF
0160 ADATA (2,I) = ADATA (2,I) + ADATA (1,319)
0161 BDATA (2,I) = BDATA (2,I) + BDATA (1,319)
030 I = I + 1
0162 DO 050 J = -60,60,15
0163 JJ = J
0164 JJ = JJ / 2
0165 IF ( J .EQ. -60 ) JJ = -65
0166 IF ( J .EQ. 60 ) JJ = 55
0167 II = II + 1
0168 DO 035 I = 1,150,1
0169 IF (ADATA(1,I) .LT. JJ ) GOTO 035
0170 Y1 = ADATA(1,I-2)
0171 P1 = ADATA(2,I-2)
0172 Y2 = ADATA(1,I-1)
0173 P2 = ADATA(2,I-1)
0174 Y3 = ADATA(1,I)
0175 P3 = ADATA(2,I)
0176 Y4 = ADATA(1,I+1)
0177 P4 = ADATA(2,I+1)
0178 GOTO 040
035 CONTINUE
040 DO 045 I = 151,300,1
041 IF ( ADATA(1,I) .GT. JJ ) GOTO 045
042 Y5 = ADATA(1,I-2)
043 P5 = ADATA(2,I-2)
044 Y6 = ADATA(1,I-1)
045 P6 = ADATA(2,I-1)
046 Y7 = ADATA(1,I)
047 P7 = ADATA(2,I)
048 Y8 = ADATA(1,I+1)
049 P8 = ADATA(2,I+1)
050 GOTO 050
045 CONTINUE
050 X1(1) = Y1
051 X1(2) = Y2
052 X1(3) = Y3
053 X1(4) = Y4
054 X1(5) = Y5
055 X1(6) = Y6
056 X1(7) = Y7
057 X1(8) = Y8
058 Y (1) = P1
059 Y (2) = P2
060 Y (3) = P3
061 Y (4) = P4
062 Y (5) = P5
063 Y (6) = P6
064 Y (7) = P7
065 Y (8) = P8
066 YAWA(11) = (Y1+Y2+Y3+Y4+Y5+Y6+Y7+Y8) / 8
067 PA (11) = (P1+P2+P3+P4+P5+P6+P7+P8) / 8
068 DO 060 I = 26,125,1
069 J = I - 25
070 X1(I) = BDATA(1,I)
071 Y (I) = BDATA(2,I)
060 DO 045 I = 176,375,1
061 J = I - 75
062 X1(I) = BDATA(1,I)
063 Y (I) = BDATA(2,I)
064 NPNTS = 200
065 CALL MAT2 (NPNTS,7,COEF,-1)
066 DO 070 I = 1,9,1
067 YAMB(I) = 7.5 * ( I - 5 )
070 PB (I) = FNP(6,COEF,YAMB(I))
071
072 WRITE (LI,159)
073 DO 075 I = 1,9,1

```

Figure E-2. Listing of Calibration Data Evaluation Program &EVALU.
(Continued on next page.)

```

0237 WRITE (LI,160) ,PAMAX,PSA ,PAMAXI,YAWAI)
0240 PRARO = (ADATA(2,319) + RDATA(2,319)) / 2
0241 PSTAT = PRARO * 13.585
0242 PTOTAL = ((ADATA(2,318) + BDATA(2,318)) / 2) + (PRARO * 13.585)
0243 XVELME = SQRT ( 1 - (PTOTAL/PSTAT) **(-0.2857) )
0244 PHIME = ADATA(1,320)
0245 DO 080 I = 1,9,1
0246 X1(I) = YAWAI)
0247 Y(I) = PA(I) + ( PRARO * 13.585 )
0248 CALL MAT2 (9,5,COEF,-4)
0249
0250 .....
0251 .....
0252 .....
0253 .....
0254 .....
0255 .....
0256 .....
0257 085 DX = 126.0
0258 X0 = -70.0
0259 IF (ABS(DP) .LT. 0.0001) GOTO 090
0260 DPX = 2.*COEF(3)*DX-6.*COEF(4)*X0*DX-3.*COEF(4)*DX*DX-
0261 * 12.*COEF(5)*X0*X0*DX-12.*COEF(5)*X0*DX*DX-4.*COEF(5)*DX**3
0262 X0 = X0 - DP / DPX
0263 GOTO 085
0264 090 ASL = X0
0265 ASR = X0 + DX
0266 AA0 = X0 + DX / 2.0
0267 PAMAX = FNP(4,COEF,AA0)
0268 PSAL = FNP(4,COEF,ASL)
0269 PSAR = FNP(4,COEF,ASR)
0270 PSA = (PSAL + PSAR) / 2.0
0271 PTOTAL = PAMAX
0272 BETA = (PAMAX - PSA) / PAMAX
0273 CPAMAX = (PAMAX - PSA) / (PTOTAL - PSA)
0274 IF ( IPRINT .NE. 2HYE ) GOTO 095
0275 WRITE (LI,161) ASL,AA0,ASR,PSAL,PAMAX,PSAR,CPAMAX
0276 IF (LO .NE. 0) WRITE (LO,161) ASL,AA0,ASR,PSAL,PAMAX,PSAR,CPAMAX
0277 095 CONTINUE
0278 .....
0279 .....
0280 .....
0281 .....
0282 .....
0283 .....
0284 .....
0285 .....
0286 .....
0287 .....
0288 .....
0289 .....
0290 .....
0291 .....
0292 .....
0293 .....
0294 .....
0295 .....
0296 .....
0297 .....
0298 .....
0299 .....
0300 .....
0301 .....
0302 .....
0303 .....
0304 .....
0305 .....
0306 .....
0307 .....
0308 .....
0309 .....
0310 .....
0311 .....
0312 .....
0313 .....
0314 .....
0315 .....
0316 .....
0317 .....
0318 .....

```

Figure E-2. Listing of Calibration Data Evaluation Program &EVALU. (Continued on next page.)

```

0319       IF (IS .EQ. 46 ) GOTO 250
0320       GOTO 260
0321 210 AFILE(1) = 2HA3
0322       RFILE(1) = 2HB3
0323       IJI = IS - 9
0324       WRITE (LO,604)
0325       GOTO 260
0326 220 AFILE(1) = 2HA4
0327       RFILE(1) = 2HB4
0328       IJI = IS - 18
0329       WRITE (LO,604)
0330       GOTO 260
0331 230 AFILE(1) = 2HA5
0332       RFILE(1) = 2HB5
0333       IJI = IS - 27
0334       WRITE (LO,604)
0335       GOTO 260
0336 240 AFILE(1) = 2HA6
0337       RFILE(1) = 2HB6
0338       IJI = IS - 36
0339       WRITE (LO,604)
0340       GOTO 260
0341 250 AFILE(1) = 2HA7
0342       RFILE(1) = 2HB7
0343       IJI = IS - 45
0344       WRITE (LO,604)
0345       GOTO 260
0346 260 IF ( IJI .EQ. 1 ) GOTO 300
0347       IF ( IJI .EQ. 2 ) GOTO 310
0348       IF ( IJI .EQ. 3 ) GOTO 320
0349       IF ( IJI .EQ. 4 ) GOTO 330
0350       IF ( IJI .EQ. 5 ) GOTO 340
0351       IF ( IJI .EQ. 6 ) GOTO 350
0352       IF ( IJI .EQ. 7 ) GOTO 360
0353       IF ( IJI .EQ. 8 ) GOTO 370
0354       IF ( IJI .EQ. 9 ) GOTO 380
0355 300 AFILE(2) = 2H25
0356       AFILE(3) = 2HK5
0357       GOTO 400
0358 310 AFILE(2) = 2H20
0359       AFILE(3) = 2HKP
0360       GOTO 400
0361 320 AFILE(2) = 2H15
0362       AFILE(3) = 2HKP
0363       GOTO 400
0364 330 AFILE(2) = 2H10
0365       AFILE(3) = 2HKP
0366       GOTO 400
0367 340 AFILE(2) = 2H05
0368       AFILE(3) = 2HKP
0369       GOTO 400
0370 350 AFILE(2) = 2H00
0371       AFILE(3) = 2HKP
0372       GOTO 400
0373 360 AFILE(2) = 2H05
0374       AFILE(3) = 2HKN
0375       GOTO 400
0376 370 AFILE(2) = 2H10
0377       AFILE(3) = 2HKN
0378       GOTO 400
0379 380 AFILE(2) = 2H15
0380       AFILE(3) = 2HKN
0381       GOTO 400
0382 400 RFILE(2) = AFILE(2)
0383       RFILE(3) = AFILE(3)
0384       GOTO 025
0385 500 STOP '*****'
0386       END
0387 REAL FUNCTION FNP(NORDER,COEFF,ZX)
0388 REAL COEFF(6)
0389 A1 = COEFF(NORDER+1)
0390 IF ( NORDER .EQ. 0 ) GOTO 02
0391 DO 01 I = 1,NORDER,1
0392 I = NORDER + 1 - I
0393 A1 = (COEFF(I)+ZX**I)
0394 FNP = A1
0395 RETURN
0396 *
0397 REAL FUNCTION FND(NORDER,COEFF,ZX)
0398 REAL COEFF(6)
0399 REAL COEFFD(6)
0400 DO 01 I = 1,NORDER,1
0401 COEFFD(I) = COEFF(I+1)*I
0402 A1 = COEFFD(NORDER)
0403 NORDR = NORDER - 1
0404 IF ( NORDR .EQ. 0 ) GOTO 03
0405 DO 02 I = 1,NORDR,1
0406 I = (NORDR + 1) - I
0407 A1 = COEFFD(I)+ZX**I
0408 FND = A1
0409 RETURN
0410 END

```

Figure E-2. Listing of Calibration Data Evaluation Program &EVALU.

APPENDIX F

CALIBRATION TEST PROGRAM TEST

Chapter 5.2 describes the test and the test procedure used to verify the quality of the calibration in a freejet experiment. Although this experiment lacks the simulation of high frequency flow vector changes like those to be expected in its application, it seems to be the most useful check of the calibration itself and the data reduction procedure. While the set-up of the experiment and the data acquisition procedure were described in 5.2 already, details of computer program `STEST`, which is used to perform the data acquisition and the data reduction, will be given herein.

Like program `&EVALU`, this program first reads the calibration coefficient files into two arrays. It then asks the operator to key in the barometric pressure in inches of mercury. The data acquisition itself is performed in a DO-loop, interactively with the operator. Both probes are set to nine different yaw angles and data samples are recorded. The actual pressure and yaw angle values which are used are the averages of 30 single samples each, in order to exclude any influence of some flow irregularities. Once the data is taken, the data acquisition system is released from the HP 21-MX computer control and the data reduction is started.

The nine pressure values of the A-probe are approximated with a fourth-order polynomial as a function of the yaw angle. From this approximated curve pressure values PSAL, PSAR and PAMAX are derived which are used to calculate CPAMAX and BETA. The output of the B probe is approximated the same way and the pressure PBMAX is calculated from this curve. Using PBMAX and the results of the A probe, CPBMAX and GAMMA are established. The coefficients BETA and GAMMA alone are used to derive values of Mach number (or X) and pitch angle (ϕ). The yaw angle which corresponds to the pressure value PBMAX is assumed to be the flow yaw angle. It should be close to zero since the probes are aligned with the freejet for a zero yaw angle, unless an "artificial" yaw angle has been superimposed on them as described in 5.2

The calculated values are compared to those the freejet was adjusted to. In 5.2 the results of these comparisons were demonstrated already.

Labeled common block:

Common block identifier:	Variable:
DTA2	X1,Y

<u>Variable</u>	<u>Type</u>	<u>Description</u>
AAO	Real	Flow yaw angle derived from A probe
ABO	Real	Flow yaw angle derived from B probe
AKULIT	Real	Average value of 30 A probe pressure samples

<u>Variable</u>	<u>Type</u>	<u>Description</u>
APRESS	Real	Single sample value of A probe pressure reading
ASL	Real	Left-hand side yaw angle of A probe output
ASR	Real	Right-hand side yaw angle of A probe output
BKULIT	Real	Average value of 30 B probe pressure samples
BPRESS	Real	Single sample value of B probe pressure reading
COEF(7)	Real	Array to contain coefficients from 2-D approximations
COEUX(7,7)	Real	Array containing the coefficients of the 3-D approximation for the velocity
COEUP(7,7)	Real	Array containing the coefficients of the 3-D approximation for the pitch angle
CPAMAX	Real	Maximum pressure coefficient A probe
CPBMAX	Real	Maximum pressure coefficient B probe
DP	Real	Pressure difference for two pressure values corresponding to two yaw angles which are separated by DX
DPX	Real	First derivative of the function $P_A(\alpha) - P_A(\alpha - \Delta\alpha)$
DX	Real	Given spread in yaw angle between PSAL and PSAR
GAMMA	Real	Pressure coefficient
ICR	Integer	Cartridge reference number
IDCB(144)	Integer	Data control block
IDCBS	Integer	Control block length (of IDCB)
IFILE(3)	Integer	Array containing file name

<u>Variable</u>	<u>Type</u>	<u>Description</u>
ISECU	Integer	Security code
ISIZE(2)	Integer	Array to specify file dimensions
ITYPE	Integer	Type of data file
ICLR(3)	Integer	Command to clear line above cursor
NOLF	Integer	No line feed command
PA(9)	Real	Array for A probe pressure values
PAMAX	Real	Maximum pressure of A probe
PB(9)	Real	Array for B probe pressure values
PBARO	Real	Barometric pressure inches of mercury
PBMAX	Real	Maximum pressure of B probe
PHI	Real	Pitch angle (calculated)
PSA	Real	Static pressure equivalent of A probe
PSAL	Real	Pressure reading of A probe for a yaw angle 63° to the left of the flow aligned yaw angle
PSAR	Real	Pressure reading of A probe for a yaw angle 63° to the right of the flow aligned yaw angle
PTOTAL	Real	Total pressure
XVEL	Real	Mach number equivalent dimensionless speed
X0	Real	Starting value for the iteration to find PSAL and PSAR
X1(256)	Real	Data array for 2-D approximations
Y(256)	Real	Data array for 2-D approximations
YAWANG	Real	Single sample of yaw angle reading
YAWKUL	Real	Average value of 30 yaw angle readings

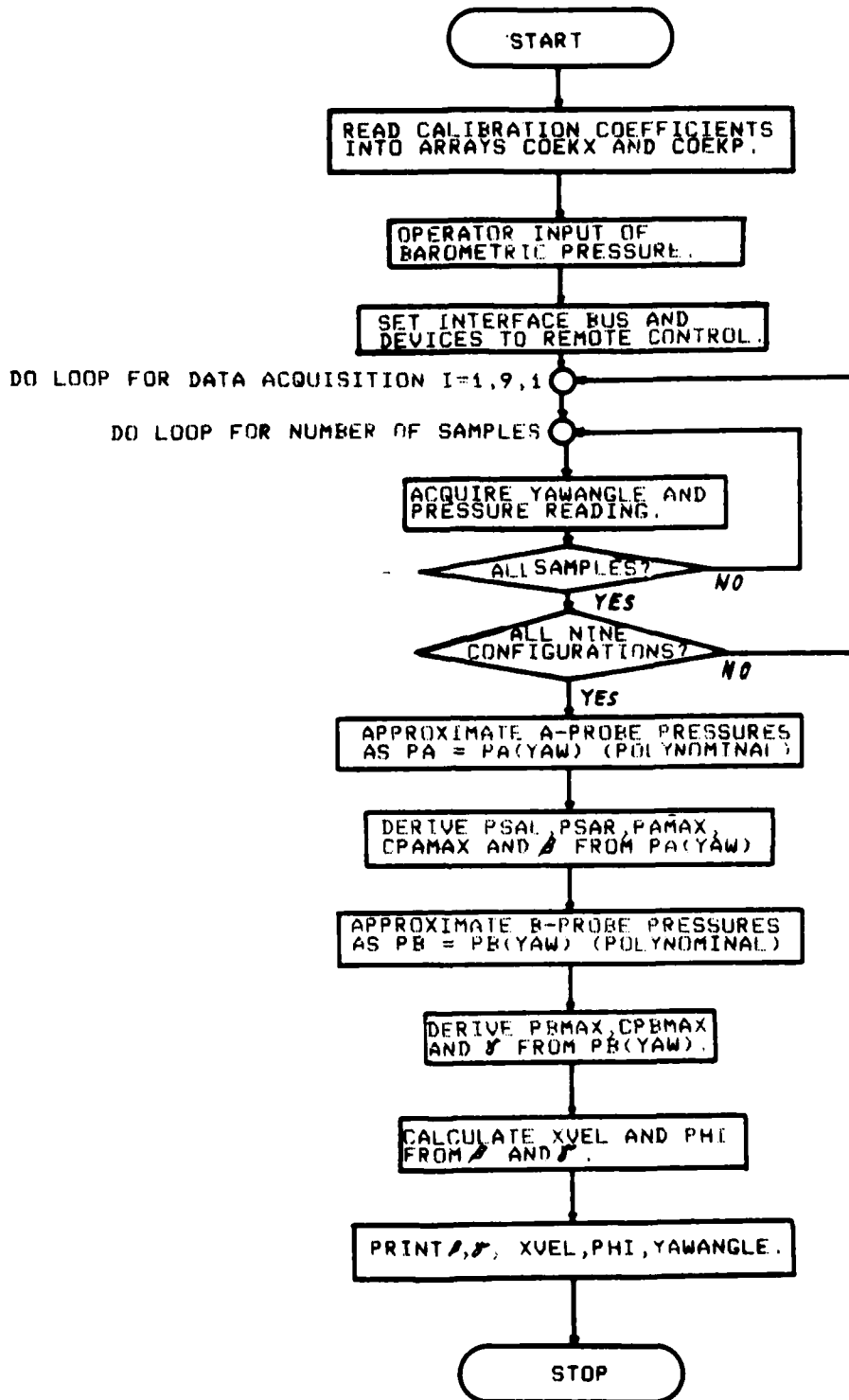

Figure F-1. Flow Chart of Calibration Evaluation Program &TEST.

```

ATEST T=00004 IS ON CR00026 USING 00055 BLKS R=0000
0001 FTN4,L
0002 PROGRAM TEST (3,99)
0003 .....
0004 THIS IS PROGRAM TEST FOR THE A-B PROBE SYSTEM.
0005 .....
0006 IT ACQUIRES DATA FROM THE A-R PROBES MOUNTED IN THE FREE-
0007 JET IN ORDER TO CHECK THE VALIDITY OF THE CALIBRATION.
0008 THE DATA IS NOT STORED, ONLY AN ONLINE OUTPUT IS AVAI-
0009 LABLE.
0010 .....
0011
0012
0013
0014
0015
0016 COMMON /DTA2/ X1,Y1
0017 REAL X1(256),Y1(256)
0018 REAL COEF(7),COEXX(7,7),COEKP(7,7)
0019 REAL PA(9),PB(9),YAW(9)
0020 INTEGER IDCR(144),IFILE(3),ISIZE(2)
0021 INTEGER NOLFP,ICLR(13)
0022 DATA IDCBS / 144 /
0023 DATA TYPE / 1 /
0024 DATA ICLR / 015524B,015415B,006537B /
0025 DATA NOLFS / 006537B /
0026 101 FORMAT (' OUTPUT INPUT DATA TO ANY OTHER DEVICE? ENTER NO
0027 * OR LUB *'/' - "A2")
0028 102 FORMAT (' DO YOU WANT AN OUTPUT OF THE CALIBRATION COEFFICIENTS?'
0029 *? ENTER YES IF SO OR ANYTHING ELSE IF NOT!')
0030 103 FORMAT (' DO YOU WANT AN OUTPUT OF THE CONTROLL PARAMETERS?/' KE
0031 *? YES IF SO OR ANYTHING ELSE IF NOT!')
0032 104 FORMAT ('// THE DATA READ FROM FILE "3A2" ARE//')
0033 105 FORMAT (' I / J -112,6116)
0034 106 FORMAT (' I / J -112,6116)
0035 107 FORMAT (' I3,7(1X,F15.6))
0036 108 FORMAT (' I / J -112,6116)
0037 109 FORMAT (' ENTER P BARO IN INCHES HG !')
0038 110 FORMAT (' R A W D A T A "/ " * A - KULITE, B - KULITE "9X"YAW")
0039 111 FORMAT (' WHEN YOU ARE READY FOR YAW ANGLE * "I2" HIT CR !')
0040 112 FORMAT (I3,3(2X,F10.5))
0041 113 FORMAT(' A-PROBE APPROXIMATION RESULTS : YAW = "3(5X,F9.2)/16X" PR
0042 ESSURE (INCH H2O) = "3(3X,F11.6)/29X" CPAMAX = "F0.4/")
0043 114 FORMAT(' B-PROBE APPROXIMATION RESULTS : YAWO = "F5.1" PRESSURE
0044 (INCH H2O) = "F5.2//')
0045 115 FORMAT(' AVERAGE VALUE RESULTS FROM THE A-R SYSTEM: "/5X"BETA"4X"G
0046 *AMMA"5X"XV1"4X"Pitch"6X"Yaw"/3(F9.5),2(2X,F7.2))
0047 149 FORMAT ((3A2))
0048 150 FORMAT (I2)
0049 1111 FORMAT (' STATEMENT * "I4" ERROR * : "F12.0" DETECTED")
0050 1001 FORMAT ("FIR7M3A0M03")
0051 1501 FORMAT ("CA")
0052 LI LOGLU(ISESSN)
0053 005 WRITE (LI,101) NOLFP
0054 READ (LI,149) IDUM
0055 IF ( IDUM .EQ. 0MNO ) GO TO 010
0056 CALL CODE
0057 READ (IDUM,150) LO
0058 IF ( LO .EQ. 1 ) GO TO 015
0059 IF ( LO .EQ. 2 ) GO TO 015
0060 IF ( LO .EQ. 18 ) GO TO 015
0061 GO TO 005
0062 010 LO = 1
0063 015 IF ( LO .EQ. LI ) LO = 0
0064 WRITE (LI,102)
0065 READ (LI,149) IPRINT
0066 WRITE (LI,103)
0067 READ (LI,149) IPRINT
0068 .....
0069 READ FILE SIFX22 FROM DISC INTO ARRAY COEXX(7,7).
0070 .....
0071
0072
0073
0074
0075
0076
0077
0078
IFILE(1) = 3M51
IFILE(2) = 3M7
IFILE(3) = 3M43
ISELU = 00
ICM = 26
CALL OPEN (IDCR,ISERR,IFILE,ISOPTM,ISEL,ICR,ISDCBS)

```

Figure F-2. Listing of Program to Test the Quality of the Calibration: &TEST.
(Continued on next page.)

```

0079      JJ = 1
0080      IF ( IERR .LT. 0 ) WRITE (LI,1111) JJ,IERR
0081      CALL READF (IDCB,IERR,COEKX,98,LEN,1)
0082      JJ = 2
0083      IF ( IERR .LT. 0 ) WRITE (LI,1111) JJ,IERR
0084      CALL CLOSE (IDCB,IERR,0)
0085      JJ = 3
0086      IF ( IERR .LT. 0 ) WRITE (LI,1111) JJ,IERR
0087      IF (IPRINI .NE. 2HYE) GOTO 025
0088      .....
0089      OUTPUT INPUT DATA.
0090      .....
0091      CCCCCC
0092      .....
0093      WRITE (LI,104) IFILE
0094      IF ( LO .NE. 0 ) WRITE (LO,104) IFILE
0095      WRITE (LI,105) (I1,I1=1,7)
0096      IF ( LO .NE. 0 ) WRITE (LO,106) (I1,I1=1,7)
0097      DO 020 I1=1,7,1
0098      IF ( LO .NE. 0 ) WRITE (LO,107) I1,(COEKX(I1,J1),J1=1,7,1)
0099      020 WRITE (LI,108) I1,(COEKX(I1,J1),J1=1,7,1)
0100      .....
0101      READ FILE SIFP22 FROM DISC INTO ARRAY COEKP(7,7).
0102      .....
0103      CCCCCC
0104      .....
0105      025 IFILE(1) = 2MSI
0106      IFILE(2) = 2MFP
0107      IFILE(3) = 2H43
0108      CALL OPEN (IDCB,IERR,IFILE,IOPTN,ISECU,ICR,IDCBS)
0109      JJ = 4
0110      IF ( IERR .LT. 0 ) WRITE (LI,1111) JJ,IERR
0111      CALL READF (IDCB,IERR,COEKP,98,LEN,1)
0112      JJ = 5
0113      IF ( IERR .LT. 0 ) WRITE (LI,1111) JJ,IERR
0114      CALL CLOSE (IDCB,IERR,0)
0115      JJ = 6
0116      IF ( IERR .LT. 0 ) WRITE (LI,1111) JJ,IERR
0117      IF (IPRINI .NE. 2HYE) GOTO 035
0118      .....
0119      OUTPUT INPUT DATA.
0120      .....
0121      CCCCCC
0122      .....
0123      WRITE (LI,104) IFILE
0124      IF ( LO .NE. 0 ) WRITE (LO,104) IFILE
0125      WRITE (LI,105) (I1,I1=1,7)
0126      IF ( LO .NE. 0 ) WRITE (LO,106) (I1,I1=1,7)
0127      DO 030 I1=1,7,1
0128      IF ( LO .NE. 0 ) WRITE (LO,107) I1,(COEKP(I1,J1),J1=1,7,1)
0129      030 WRITE (LI,108) I1,(COEKP(I1,J1),J1=1,7,1)
0130      035 CONTINUE
0131      .....
0132      THE DATA ACQUISITION SHALL BE PERFORMED NOW !
0133      .....
0134      CCCCCC
0135      .....
0136      WRITE (LI,109)
0137      READ (LI,*) PBOARD
0138      CALL ARRT (7,2)
0139      CALL RMOTE (10)
0140      CALL RMOTE (15)
0141      .....
0142      WRITE (10,1001)
0143      WRITE (15,1501)
0144      .....
0145      WRITE (LO,110)
0146      DO 050 I = 1,7,1
0147      040 WRITE (LI,111) I
0148      READ (LI,149) IDUM
0149      IF ( IDUM .NE. 2H ) GOTO 040
0150      AKULIT = 0.0
0151      YAWKUL = 0.0
0152      BKULIT = 0.0
0153      DO 045 J = 1,30,1
0154      YAWANG = SCANN (15,22,01)
0155      RPRESS = SCANN (15,23,01)
0156      APRESS = SCANN (15,24,01)
0157      AKULIT = AKULIT + APRESS
0158

```

Figure F-2. Listing of Program to Test the Quality of the Calibration: &TEST.
(Continued on next page.)

```

0159 YAMKUL = YAMKUL + YAMANG
0160 BKULIT = BKULIT + RPNRES
0161 PA(I) = BKULIT / 30
0162 PB(I) = BKULIT / 30
0163 YAW(I) = YAMKUL / 30
0164 050 WRITE (LO,112) I,PA(I),PB(I),YAW(I)
0165 CALL CLEAR (7,1)
0166 CALL LOCL (7)
0167
0168 .....
0169 .....
0170 .....
0171 .....
0172 .....
0173 .....
0174 .....
0175 .....
0176 .....
0177 .....
0178 .....
0179 .....
0180 .....
0181 .....
0182 .....
0183 .....
0184 .....
0185 .....
0186 .....
0187 .....
0188 .....
0189 .....
0190 .....
0191 .....
0192 .....
0193 .....
0194 .....
0195 .....
0196 .....
0197 .....
0198 .....
0199 .....
0200 .....
0201 .....
0202 .....
0203 .....
0204 .....
0205 .....
0206 .....
0207 .....
0208 .....
0209 .....
0210 .....
0211 .....
0212 .....
0213 .....
0214 .....
0215 .....
0216 .....
0217 .....
0218 .....
0219 .....
0220 .....
0221 .....
0222 .....
0223 .....
0224 .....
0225 .....
0226 .....
0227 .....
0228 .....
0229 .....
0230 .....
0231 .....
0232 .....
0233 .....
0234 .....
0235 .....
0236 .....
0237 .....
0238 .....
0239 .....
0240 .....
0241 .....
0242 .....
0243 .....
0244 .....
0245 .....
0246 .....
0247 .....
0248 .....
0249 .....
0250 .....
0251 .....
0252 .....
0253 .....
0254 .....
0255 .....
0256 .....
0257 .....
0258 .....
0259 .....
0260 .....
0261 .....
0262 .....
0263 .....
0264 .....
0265 .....
0266 .....
0267 .....
0268 .....
0269 .....
0270 .....
0271 .....
0272 .....
0273 .....
0274 .....
0275 .....
0276 .....
0277 .....
0278 .....
0279 .....
0280 .....
0281 .....
0282 .....
0283 .....
0284 .....
0285 .....
0286 .....
0287 .....
0288 .....
0289 .....
0290 .....
0291 .....
0292 .....
0293 .....
0294 .....
0295 .....
0296 .....
0297 .....
0298 .....
0299 .....
0300 .....
0301 .....
0302 .....
0303 .....
0304 .....
0305 .....
0306 .....
0307 .....
0308 .....
0309 .....
0310 .....
0311 .....
0312 .....
0313 .....
0314 .....
0315 .....
0316 .....
0317 .....
0318 .....
0319 .....
0320 .....
0321 .....
0322 .....
0323 .....
0324 .....
0325 .....
0326 .....
0327 .....
0328 .....
0329 .....
0330 .....
0331 .....
0332 .....
0333 .....
0334 .....
0335 .....
0336 .....
0337 .....
0338 .....
0339 .....
0340 .....
0341 .....
0342 .....
0343 .....
0344 .....
0345 .....
0346 .....
0347 .....
0348 .....
0349 .....
0350 .....
0351 .....
0352 .....
0353 .....
0354 .....
0355 .....
0356 .....
0357 .....
0358 .....
0359 .....
0360 .....
0361 .....
0362 .....
0363 .....
0364 .....
0365 .....
0366 .....
0367 .....
0368 .....
0369 .....
0370 .....
0371 .....
0372 .....
0373 .....
0374 .....
0375 .....
0376 .....
0377 .....
0378 .....
0379 .....
0380 .....
0381 .....
0382 .....
0383 .....
0384 .....
0385 .....
0386 .....
0387 .....
0388 .....
0389 .....
0390 .....
0391 .....
0392 .....
0393 .....
0394 .....
0395 .....
0396 .....
0397 .....
0398 .....
0399 .....
0400 .....
0401 .....
0402 .....
0403 .....
0404 .....
0405 .....
0406 .....
0407 .....
0408 .....
0409 .....
0410 .....
0411 .....
0412 .....
0413 .....
0414 .....
0415 .....
0416 .....
0417 .....
0418 .....
0419 .....
0420 .....
0421 .....
0422 .....
0423 .....
0424 .....
0425 .....
0426 .....
0427 .....
0428 .....
0429 .....
0430 .....
0431 .....
0432 .....
0433 .....
0434 .....
0435 .....
0436 .....
0437 .....
0438 .....
0439 .....
0440 .....
0441 .....
0442 .....
0443 .....
0444 .....
0445 .....
0446 .....
0447 .....
0448 .....
0449 .....
0450 .....
0451 .....
0452 .....
0453 .....
0454 .....
0455 .....
0456 .....
0457 .....
0458 .....
0459 .....
0460 .....
0461 .....
0462 .....
0463 .....
0464 .....
0465 .....
0466 .....
0467 .....
0468 .....
0469 .....
0470 .....
0471 .....
0472 .....
0473 .....
0474 .....
0475 .....
0476 .....
0477 .....
0478 .....
0479 .....
0480 .....
0481 .....
0482 .....
0483 .....
0484 .....
0485 .....
0486 .....
0487 .....
0488 .....
0489 .....
0490 .....
0491 .....
0492 .....
0493 .....
0494 .....
0495 .....
0496 .....
0497 .....
0498 .....
0499 .....
0500 .....

```

Figure F-2. Listing of Program to Test the Quality of the Calibration: &TEST.
(Continued on next page.)

```

0239      A1 = COEFF(NORDER+1)
0240      IF ( NORDER .EQ. 0 ) GOTO 02
0241      DO #1 I= 1,NORDER,1
0242      I = NORDER + 1 - I
0243      01 A1 = COEFF(I)+ZXA1
0244      02 FNP = A1
0245      RETURN
0246      END
0247      REAL FUNCTION FND(NORDER,COEFF,ZX)
0248      REAL COEFF (7)
0249      REAL COEFFD(6)
0250      DO #1 I=1,NORDER,1
0251      01 COEFFD(I) = COEFF(I+1)*I
0252      A1 = COEFFD(NORDER)
0253      NORDR = NORDER - 1
0254      IF ( NORDR .EQ. 0 ) GOTO 03
0255      DO #2 I= 1,NORDR,1
0256      I = (NORDR + 1) - I
0257      02 A1 = COEFFD(I)+ZXA1
0258      03 FND =A1
0259      RETURN
0260      END
0261      REAL FUNCTION SCANR (LU,ICHAN,K)
0262      .....
0263      * Close relay ICHAN on scanner LU and read the instrument
0264      * indicated by K.
0265      * Author: Robert M. Geopfarth
0266      * Date: February 31, 1979
0267      * Detailed program description is available in TXCO log; the
0268      * variables are:
0269      * LU ... LU# of desired scanner (8 or 15).
0270      * ICHAN ... Scanner channel (integer).
0271      * IC ... Scanner channel (ASCII).
0272      * K ... Instrument code ( DVM = 1 / Counter = 2 ).
0273      .....
0274      * Closes scanner and reads DVM, counter. *
0275      .....
0276      101 FORMAT (A2)
0277      801 FORMAT (" ")
0278      1001 FORMAT ("T3T3")
0279      1201 FORMAT ("T")
0280      1501 FORMAT ("C")
0281
0282      WRITE ( 8, 801)
0283      WRITE (15,1501)
0284      IC = ICON(ICHAN,0)
0285      WRITE (LU, 101) IC
0286      GO TO (01,02) K
0287
0288      01 CALL TRIGR (10)
0289      READ (10, *) DVM
0290      CALL TRIGR (10)
0291      READ (10, *) SCANR
0292      GO TO 03
0293
0294      02 WRITE (12,1201)
0295      READ (12, *) SCANR
0296
0297      03 WRITE (LU, 801)
0298      RETURN
0299      END
0300      INTEGER FUNCTION ICON(I,N)
0301      IC=I+N
0302      IF (IC.LT.10) GO TO 100
0303      CALL CODE
0304      WRITE(ICON,60)IC
0305      60 FORMAT(I2)
0306      RETURN
0307      100 ICON=IC+30060B
0308      RETURN
0309      END
0310

```

Figure F-2. Listing of Program to Test the Quality of the Calibration: &TEST.

APPENDIX G

CALIBRATION DATA (C_{POB}) APPROXIMATION PROGRAM &RES10

As shown in Fig. 19, $CPBO$ is well behaved as a function of pitch angle and Mach number as well. Thus it is approximated as a function of these two variables. Program &RES10 handles this procedure. It is in principal again the same program as &REST8, like &REST9, so that a detailed program description will not be given here. However, it shall be mentioned here that the data which is the basis of the approximation is contained in data file ABNEW2. This is an indication that this file contains all the data necessary to represent the whole calibration.

For the evaluation of the quality of the approximation, errors are printed out as were for &REST8. These are calculated as:

$$\epsilon_{CPBO} = \frac{C_{PB0m} - C_{PB0c}}{C_{PB0m}} \cdot 100$$

index m = known from measurement

index c = calculated

The variation in the order of polynomials for the approximation was changed in two DO-loops also and the one for the best error results chosen. Those coefficients are stored in file MISTCP on cartridge 26. Figure G-1 shows the coefficients

and the associated errors. The highlighted area gives the range of Mach number and pitch angle which will most likely occur. Thus the error distribution within there is most important.

Figure G-2 gives a listing of program &RES10. The similarities to programs &REST8 and &REST9 are obvious, so that no flow chart or further explanations are given.

COEFFICIENTS FOR THE CALIBRATION SURFACE STORED IN FILE CALIBR

Morder	Norder →	1	2	3	4
1	↓	1.000000	2.1276750	-9.600353	14.600000
2		-1.450000	1.000000	-3.500000	12.000000
3		-1.100000	-0.400000	25.200000	-15.000000
4		1.000000	2.000000	-11.000000	54.000000

ERRORS AT EACH POINT

Mach	Pitch Angle →	1	2	3	4	5	6	7	8	9	10
0.2	25°	0.000	0.000	-0.000	-0.000	0.000	1.000	0.000	0.000	0.000	-15.000
	20°	-0.000	0.000	-0.000	-0.000	-0.000	0.000	0.000	0.000	0.000	0.000
	15°	0.000	0.000	0.000	0.000	0.000	-0.000	0.000	0.000	0.000	0.000
	10°	-0.000	0.000	-0.000	-0.000	-0.000	0.000	0.000	0.000	0.000	0.000
0.7	25°	0.000	0.000	-0.000	-0.000	0.000	1.000	0.000	0.000	0.000	-15.000
	20°	-0.000	0.000	-0.000	-0.000	-0.000	0.000	0.000	0.000	0.000	0.000
	15°	0.000	0.000	0.000	0.000	0.000	-0.000	0.000	0.000	0.000	0.000
	10°	-0.000	0.000	-0.000	-0.000	-0.000	0.000	0.000	0.000	0.000	0.000

Table G-I. Coefficients and errors for C_{POB} approximation depending on X_{vel} and ϕ .

&RES10 T=00004 IS ON CR00026 USING 00024 BLKS R=0000

```

0001 FTN4.L
0002 PROGRAM RES10 (3,99)
0003 .....
0004 . This is program RES(store) 10.
0005 .....
0006 . There are some programs REST, which in principle do all the
0007 . same. They restore calibration data of a probe into a form
0008 . that can be used to approximate this data by a calibration
0009 . surface.
0010 . The software used for the surface approximation is available
0011 . in the Turbopropulsion Laboratory Binary Library (TPLBL).
0012 . See NPS67-HO-001CR for further reference.
0013 . In this particular case the calibration data of the
0014 .
0015 . NEW A - AND B - PROBES
0016 .
0017 . are approximated:
0018 . CpOB = f(PHI,XVEL)
0019 .....
0020 COMMON / MATRIX / A,B
0021 COMMON / SUMME / PHI,XVEL,CPOB
0022 REAL PLOTR(256),A(49,49),B(49),COEFF(7,7),D(10,54)
0023 INTEGER IDCR(144),IFILE(3),ISIZF(2),NOCR(2),ICLR(3)
0024 REAL XVEL(16,16),PHI(16,16),CPOB(16,16),R(16)
0025 DATA PI / 3.141593 /
0026 DATA IFILE / 2HAR,2HNE,2HW2 /
0027 DATA NOCR / 000033R,040433R /
0028 DATA ICLR / 015524H,015515B,006537B /
0029 DATA ISECU / 0 /
0030 DATA ICR / 26 /
0031 DATA ITYPE / 1 /
0032 DATA ISIZE / 3,128 /
0033 DATA IDCRS / 144 /
0034 101 FORMAT (" SELECT SET OF COEFFICIENTS FOR BEST RESULTS 1/" ENTER N
0035 " ORDER AND NUMBER NOW : ")
0036 149 FORMAT ("((3A2))")
0037 801 FORMAT ("///" COEFFICIENTS FOR THE CALIBRATION SURFACE STORED IN FI
0038 FILE "3A2")
0039 802 FORMAT ("(3X,16(6X,12))")
0040 803 FORMAT ("(1X,12(16(1X,57)3)/3(7X,16(1X,57)3))")
0041 804 FORMAT ("///" ERRORS AT EACH POINT (%))
0042 805 FORMAT ("(3X,10(11X,12))")
0043 806 FORMAT ("(1X,12(27(11,6)))")
0044 1111 FORMAT (" STATEMENT # "I4" ERROR # "I4" ENCOUNTERED ")
0045 LI = LOGLU(I)
0046 .....
0047 READ DATA FILE ARNEW
0048 .....
0049 .....
0050 .....
0051 .....
0052 CALL OPEN (IDCR,IFRR,IFILE,IOPFN,ISECU,ICR,ICRBS)
0053 JJ = 1
0054 IF ( IERR .LT. 0 ) WRITE (LI,1111) JJ,IERR
0055 CALL READP (IDCR,IFRR,D,1000 LEN,I)
0056 JJ = 1
0057 IF ( IERR .LT. 0 ) WRITE (LI,1111) JJ,IERR
0058 CALL CLOSE (IDCR,IERR,0)
0059 JJ = 1
0060 IF ( IERR .LT. 0 ) WRITE (LI,1111) JJ,IERR
0061 II = 0
0062 DO 005 I = 1,2
0063 DO 005 J = 1,2
0064 I = 0
0065 XVEL (I,J) = D(3,I)
0066 IF ( I .EQ. 1 ) D(4,I) = D(4,I) + 0.00001
0067 PHI (I,I) = D(4,I) * PI (30)
0068 CPOB (I,I) = D(6,I)
0069 NMAFH = 0
0070 NPTICH = 0
0071 010 CONTINUE
0072 .....
0073 .....
0074 .....
0075 .....
0076 .....
0077 .....
0078 .....
0079 .....
0080 .....
0081 .....
0082 .....
0083 .....
0084 .....
0085 .....
0086 .....
0087 .....
0088 .....
0089 .....
0090 .....
0091 .....
0092 .....
0093 .....
0094 .....
0095 .....
0096 .....
0097 .....
0098 .....
0099 .....
1000 .....

```

Figure G-1. Listing of Program to Approximation C_{pOB} Values: &RES10. (Continued on next page.)

```

0079      IJI = 0
0080      DO 060 MU = 1,6,1
0081      DO 060 NU = 1,6,1
0082      MORDER = MU
0083      NORDER = NU
0084      015 CONTINUE
0085      DO 020 I = 1,7,1
0086      DO 020 J = 1,7,1
0087      020 COEFF(I,J) = 0.0
0088      M=NORDER+1
0089      N=NORDER+1
0090      CALL COMAT (A,B,M,N,NMACH,NPITCH)
0091      NEQUS=M*N
0092      CALL ELGJ (NEQUS)
0093      I=0
0094      DO 025 I = 1,M,1
0095      DO 025 J = 1,N,1
0096      I = I+1
0097      025 COEFF(I,J) = E(I)
0098      IF ( IJI .NE. 1 ) GOTO 030
0099      IFILE(1) = 3MMI
0100      IFILE(2) = 3MST
0101      IFILE(3) = 3MCP
0102      CALL CREAT (IDCB,IERR,IFILE,ISIZE,ITYPE,ISECU,ICR,IDCBS)
0103      JJ = 4
0104      IF ( IERR .LT. 0 ) WRITE (LI,1111) JJ,IERR
0105      CALL OPEN (IDCB,IERR,IFILE,IOPIN,ISECU,ICR,IDCBS)
0106      JJ = 5
0107      IF ( IERR .LT. 0 ) WRITE (LI,1111) JJ,IERR
0108      CALL WRITF (IDCB,IERR,COEFF,98)
0109      JJ = 6
0110      IF ( IERR .LT. 0 ) WRITE (LI,1111) JJ,IERR
0111      CALL CLOSE (IDCB,IERR,0)
0112      JJ = 7
0113      IF ( IERR .LT. 0 ) WRITE (LI,1111) JJ,IERR
0114      WRITE (6,601) IFILE
0115      030 CONTINUE
0116      WRITE (6,605) (J,J=1,N,1)
0117      DO 035 I = 1,M,1
0118      035 WRITE (6,606) I,(COEFF(I,J),J=1,N,1)
0119      WRITE (6,605) (J,J=1,N,1)
0120
0121
0122
0123
0124
0125
0126
0127
0128
0129
0130
0131
0132
0133
0134
0135
0136
0137
0138
0139
0140
0141
0142
0143
0144
0145
0146
0147
0148

```

```

.....
OVERWRITE DATA ARRAY WITH CALCULATED DATA
.....
WRITE (6,604)
WRITE (6,602) (J,J=1,NPITCH,1)
DO 050 I = 1,NMACH,1
DO 045 J = 1,NPITCH,1
SUM = 0.
DO 040 I1 = 1,M,1
DO 040 I2 = 1,N,1
040 SUM=SUM+COEFF(I1,I2)*XVEL(I,J)*R(JI-1)*PHI (I,J)*R(I1-1)
045 R(J)=(CPOB(I1,J)-SUM)/CPOB(I1,J)*100
050 WRITE (6,603) (R,J,J=1,NPITCH,1)
WRITE (6,602) (J,J=1,NPITCH,1)
IF (IJI .EQ. 1) GOTO 065
060 CONTINUE
WRITE (LI,101)
READ (LI,*) MORDER,NORDER
IJI = 1
GOTO 015
065 STOP 7777
END

```

Figure G-1. Listing of Program to Approximation C_{POB} Values: &RES10.

APPENDIX H

TEST DATA ACQUISITION PROGRAM &ABKUL

Program &ABKUL is rather complex. The amount of data gathered and stored is quite extensive. Since the data reduction procedure is faster if only one file contains all data, the use of a single data file seems to be justified.

Before any data acquisition is performed, the file to contain the data is created under a name given by the operator. This way it is ensured that there is sufficient space on the cartridge to store the file. Once this is done, the data array (DATA(20,256)) is preset with zeros and the interface bus and devices are set to remote control. The first part of the data acquisition is for the first on-line calibration. Both Kulite probes are at the same radius as the rotor exit combination probe and all probe yaw angles are fixed to the same angle given by the combination probe. This one is assumed to be the time averaged flow yaw angle. The reference pressure on the back side of the Kulite transducers is changed to a known value and a set of data is recorded. This data includes the pressure readings of the Kulite probes and their reference pressure as well as all the information available from the combination probe. Once this data is collected, the Kulite probe reference pressure is changed to another value and another set of data is acquired. This

procedure is carried out for a total of four different reference pressures, allowing sufficient time after each pressure change for the measuring system to adapt to the new pressure. After the last pressure is applied, the reference pressure is reset to barometric pressure and the data acquisition for the first on-line calibration is completed. During the data acquisition the recorded data is printed out immediately so that its quality can be evaluated right away.

Before the acquisition of high speed data is performed, the operator is asked to specify the number of yaw angles he wants the Kulite probes to be moved to. A maximum of nine is possible and this number should always be favored to ensure sufficient data to cover a range of 160° in yaw angle as explained in 6.3. The program asks the operator to set both Kulite probes to the first yaw angle and to initiate the data acquisition. In a first DO-loop data from the type A probe is gathered for 256 consecutive circumferential positions. Each of the 256 values is the average of 40 single samples which are acquired on consecutive revolutions. In a second DO-loop the same kind of data is acquired from the B probe. Since the two probes are mounted on the compressor case wall separated by 270° circumferentially, the trigger numbers where the data acquisition starts are separated by a number of $1728 \text{ cts.} = 270^\circ$ for the two probes. (The trigger device splits 360° up into 2304 single counts. Both probes acquire data for 256 counts, 40° respectively. Since the rotor has 18 blades, two blade passages are covered.)

When the second DO-loop is done, steady state data from the combination probe and the Kulite probes is acquired. This data is of the same kind as that for the on-line calibration data and is in general very helpful for checking purposes. It is printed out as soon as it is acquired. From the high speed data the overall average values for all 256 positions from A and B probes are derived and printed out also.

The DO-loop is continued by the operator initializing the acquisition for another yaw angle setting of both probes.

When the data for all desired yaw positions is acquired, a second on-line calibration is performed. The results are printed out immediately so that they can be compared to those from the first calibration and obvious errors can be detected right away. From the two on-line calibrations slopes and intercepts are derived for both probes as described in 6.3.

Finally the data is stored in the assigned file.

Figure H-1 gives a flow chart of program &ABKUL, while Fig. H-2 is a listing.

<u>Variables</u>	<u>Type</u>	<u>Description</u>
AVRGA	Real	Average value of A probe output
AVRGB	Real	Average value of B probe output
BUFR(1664)	Integer	Buffer array
DATA(20,256)	Real	Data array
DCA	Real	DC-level reading of A probe
DCB	Real	DC-level reading of B probe

<u>Variables</u>	<u>Type</u>	<u>Description</u>
DE	Real	Voltage difference between combination probe and reference temperature probe thermocouple
E	Real	Voltage reading of combination probe thermocouple
FSVLTG	Real	Calibration factor Kulite probe reading
IBUFF(99)	Integer	Array for Kulite sample values
IBLADE	Integer	Number of compressor rotor blade pairs to be investigated
ICLR(3)	Integer	Command to clear line above the cursor
ICOUNT	Integer	Number of acquired data points (1 through 256)
ICR	Integer	Cartridge reference number
IDCB(144)	Integer	Data control block
IDCBS	Integer	Data control block length
IDUM	Integer	Dummy variable
IFILE(3)	Integer	Array containing file name
IL	Integer	Total number of words stored in data file (two words for one value)
ISECU	Integer	Security code
IRPM	Integer	Rotational speed derived from triggered measurements
ISIZE(2)	Integer	Array to specify fill dimensions
ITYPE	Integer	Type of data file
LI	Integer	Input device number
LO	Integer	Output device number
MASK	Integer	Masking variable
NOLF	Integer	No line feed command

<u>Variables</u>	<u>Type</u>	<u>Description</u>
PBARO	Real	Barometric pressure
PCAL	Real	Calibration pressure for the Scanivalve
PREF	Real	Reference pressure for the Kulite probes
P1, P23, P4	Real	Pressure readings for the combination probe
RPM	Real	Compressor speed as read from counter
SECON	Real	Intercept of either A or B probe calibration
SLOPE	Real	Slope of either A or B probe calibration
TARE	Real	"Zero drift" for Scanivalve transducer
X(4)	Real	Array for on-line calibration data
XIMA	Real	Immersion of A probe
XIMB	Real	Immersion of B probe
XIMC	Real	Immersion of combination probe
Y(4)	Real	Array for on-line calibration data
YAWA	Real	Yaw angle of A probe
YAWB	Real	Yaw angle of B probe
YAWC	Real	Yaw angle of C probe
YAWP	Real	Total number of yaw positions for the A and B probe

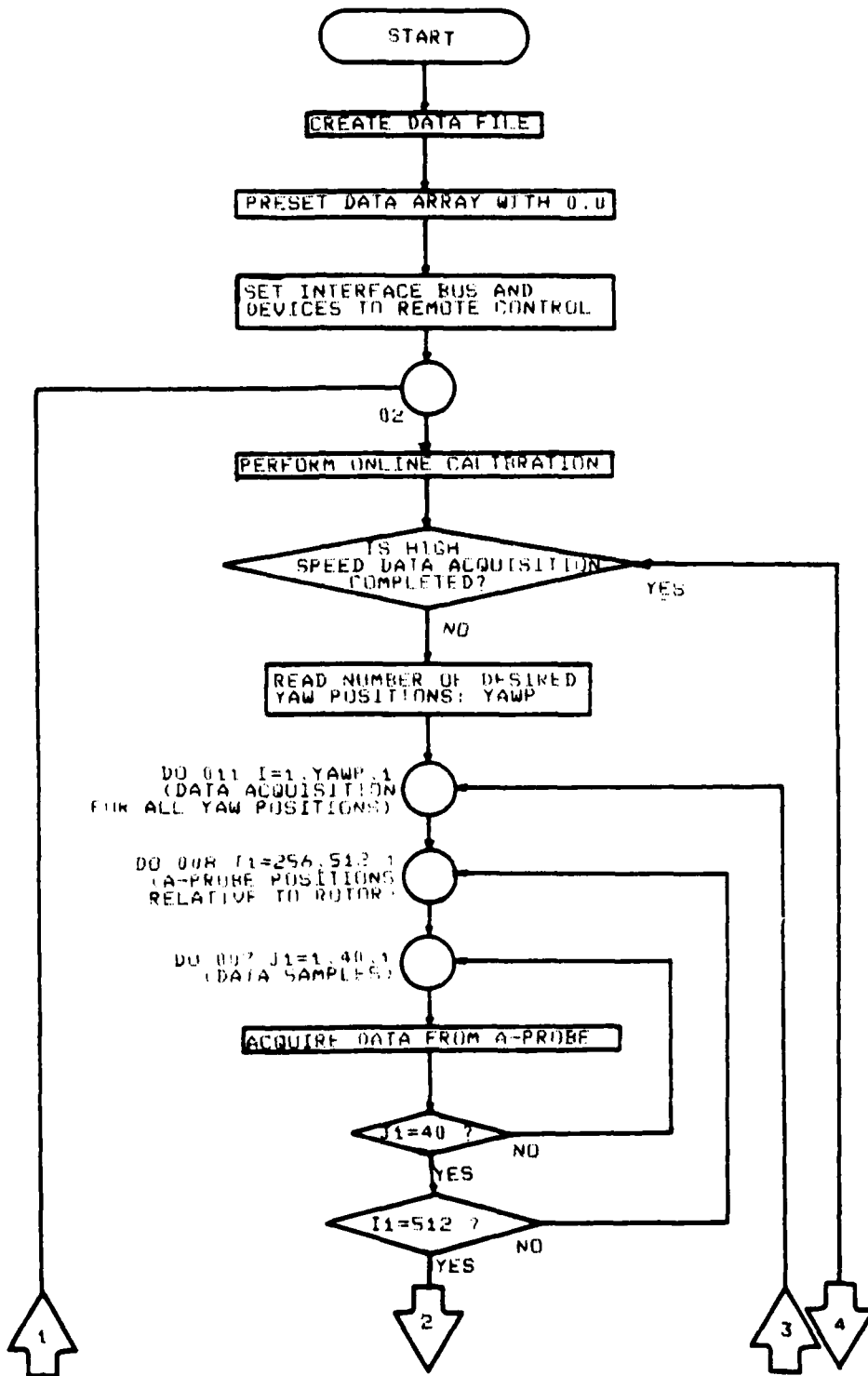

Figure H-1. Flow Chart of Data Acquisition Program &ABKUL.
(Continued on next page.)

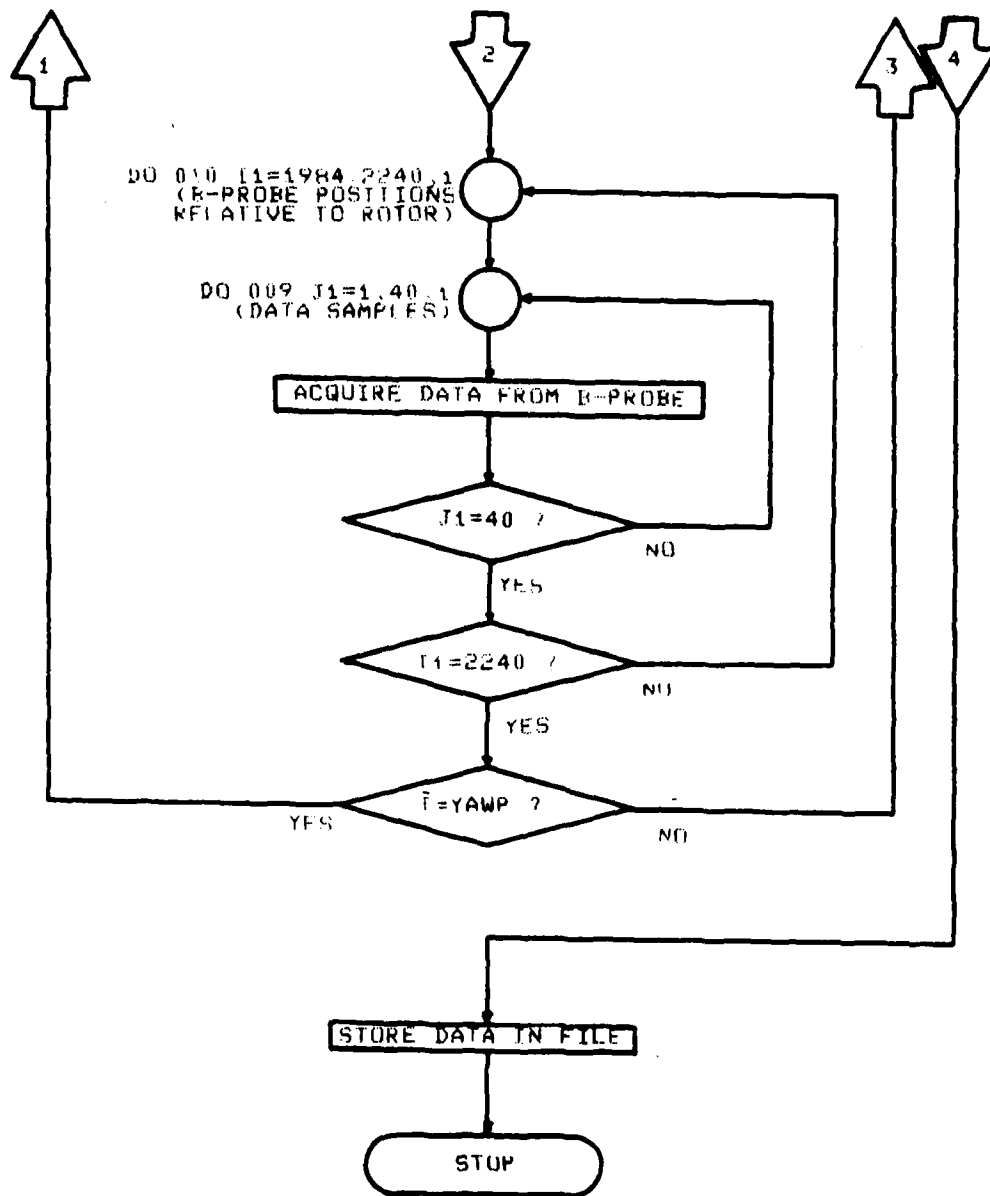

Figure H-1. Flow Chart of Data Acquisition Program SABKUL.
(Continued on next page.)

ABKUL T=0004 IS ON CR00026 USING 00061 BLKS R=0000

```
0001 FTN4,L
0002 PROGRAM ABKUL (3,99)
0003 .....
0004 .....
0005 ..... This is program ABKUL(ite).
0006 ..... It performs an online calibration of the A and B kuliteprobes
0007 ..... and a data acquisition for 7 yaw positions of these probes as
0008 ..... well.
0009 .....
0010 ..... Author : Friedrich Neuhoff
0011 ..... Date : July 28, 1981
0012 .....
0013 .....
0014 *****
0015 *
0016 * NOTE : IF THE "C" WILL BE REMOVED FROM THE STATEMENTS
0017 * CONTAINING ASTERISKS IN COLUMN 73 AND HIGHER,
0018 * NO STEADY STATE DATA WILL BE ACQUIRED AND ONLY
0019 * ONE SET OF HIGH SPEED DATA WILL BE TAKEN!
0020 *
0021 *****
0022 DIMENSION Ibuff(99), IICB(192)
0023 REAL DATA(20,256),X(4),Y(4),AVRGA,AVRCB
0024 INTEGER BUFR (1664)
0025 INTEGER NOLF, IDCRC(144), ICLR(3), IFILE(3), ISIZE(2)
0026 DATA IDCBS // 144/
0027 DATA IFCU // 00/
0028 DATA ICR // 08/
0029 DATA ITYPE // 1/
0030 DATA IL // 10240/
0031 DATA ISIZE(1) // 00/
0032 DATA ISIZE(2) // 129/
0033 DATA NOLF // 0065178/
0034 DATA ICLR // 0155348,0155158,0065378/
0035 DATA MASK // 1777008/
0036 DATA FVULTG // .1E01/
0037 101 FORMAT (" This is program ABKUL(ite)."/ " It first performs a data
0038 acquisition for an online calibration of the A and B " / " probes." /
0039 " Then it takes paced data from the probes at 7 different yaw posi-
0040 tions " / " interactively with the operator. At the end another set
0041 of data for an online " / " calibration is acquired." / " The whole r-
0042 and data is stored in one file." / " )
0043 102 FORMAT (/// " The online calibration shall be performed now." / " It
0044 allows four different reference pressures" / " When the first ref-
0045 erence pressure is applied correctly, key GU")
0046 103 FORMAT(/// "36X" Online calibration" / " )
0047 104 FORMAT(13X"Immer comb. vvw comb" / "10X"P1"9X"P2"10X"P4" / "5X"Point
0048 "immer A pr. vvw A pr." / "9X"DCR"8X"Prer"10X"Tr" / "13X"Immer B pr.
0049 " vvw B pr. "9X"DCR"9X"RPH"9X"Dit" / " )
0050 105 FORMAT ( / "12X,5(2X,F10.6) / "5X,12,5X,5(2X,F10.6) / "10X,5(2X,F10.6) )
0051 106 FORMAT (" Apply the next ref. press. and key GU when the condition
0052 "s are stable " / " enough for the next reading." )
0053 107 FORMAT(" 1st online calibration done." / " Reset the ref. press. for
0054 " the high speed data acquisition." / " Enter the number of different
0055 " yaw angles you want." / " Hit CR after that to continue." )
0056 108 FORMAT(/// "36X"Average values from paced run" / " )
0057 109 FORMAT (" Adjust both kulite probes to yaw angle number "12." Key
0058 "GU when this is done." )
0059 110 FORMAT( / "24X"A probe" / "30X"B probe" / "26X"Slope" / "6X"Intercept" / "13X"Slp
0060 "pe" / "6X"Intercept" / "47X" " / " 1st calibration" / "2(3X,F10.6) " / "2(3X,F10.6)
0061 " / "47X" " / " 2nd calibration" / "2(3X,F10.6) " / "2(3X,F10.6) )
0062 111 FORMAT (" Second online calibration done." / " Reset the ref. press.
0063 " and consider the data acquisition to be completed." / " Compare th-
0064 "e results of the two online calibrations and check for drift." / " If
0065 " the drift can be accepted, key in the file name you want the dat-
0066 "a " / " to be stored in." )
0067 112 FORMAT (" Averaged values paced output. A probe "F10.5" B probe
0068 " "F10.5" )
0069 148 FORMAT (" Output input data to any other device? Enter NO
0070 " or LU# " / " "A2" )
0071 149 FORMAT ( / "3A2" )
0072 150 FORMAT ( / "A" )
0073 801 FORMAT ("CA")
0074 1001 FORMAT ("C1R7M3A1H0T3")
0075 1201 FORMAT ("C4G6T")
0076 1501 FORMAT ("CA")
0077 .....
0078 1111 FORMAT (" STATEMENT # "15" ERROR # "17" ENCOUNTERED")
```

Figure H-2. Listing of Data Acquisition Program &ABKUL.
(Continued on next page.)

```

0079      LI = LOGU(ISESSN)
0080      77 WRITE (LI, 148) NOLF
0081         READ (LI, 149) IDUM
0082         WRITE (LI, 149) (ICLR, I1=1,2)
0083         IF ( IDUM .EQ. 'HNO' ) GO TO 78
0084         CALL CODE
0085         READ (IDUM, 150) LO
0086         IF ( LO .EQ. 1 ) GO TO 79
0087         IF ( LO .EQ. 6 ) GO TO 79
0088         IF ( LO .EQ. 18 ) GO TO 79
0089         GO TO 77
0090      78 LO = 0
0091      79 IF ( LO .EQ. LI ) LO = 0
0092         WRITE (LI, 101)
0093
0094 .....
0095 .....
0096 .....
0097 .....
0098 .....
0099 .....
0100 .....
0101 .....
0102 .....
0103 .....
0104 .....
0105 .....
0106 .....
0107 .....
0108 .....
0109 .....
0110 .....
0111 .....
0112 .....
0113 .....
0114 .....
0115 .....
0116 .....
0117 .....
0118 .....
0119 .....
0120 .....
0121 .....
0122 .....
0123 .....
0124 .....
0125 .....
0126 .....
0127 .....
0128 .....
0129 .....
0130 .....
0131 .....
0132 .....
0133 .....
0134 .....
0135 .....
0136 .....
0137 .....
0138 .....
0139 .....
0140 .....
0141 .....
0142 .....
0143 .....
0144 .....
0145 .....
0146 .....
0147 .....
0148 .....
0149 .....
0150 .....
0151 .....
0152 .....
0153 .....
0154 .....
0155 .....
0156 .....
0157 .....
0158 .....

```

Preset data array with zeros!

```

DO 01 I = 1, 20, 1
DO 01 J = 1, 256, 1
01 DATA (I, J) = 0.0

```

Set interface bus and devices to remote control !

```

CALL ABRT(7,2)
CALL RMOTE(8)
CALL RMOTE(10)
CALL RMOTE(12)
CALL RMOTE(15)
WRITE (8, 801)
WRITE (10, 1001)
WRITE (12, 1201)
WRITE (15, 1501)

```

Perform the data acquisition for the first online calibration

```

J = 1
02 GOTO 05
WRITE (LI, 102)
READ (LI, 149) IDUM
IF ( IDUM .NE. 'HNO' ) GOTO 02
WRITE (LI, 103)
IF ( LO .NE. 0 ) WRITE (LO, 103)
WRITE (LI, 104)
IF ( LO .NE. 0 ) WRITE (LO, 104)
03 TARE2 = ACQN ( 4, 1, 10 )
PCAL = ACQN ( 4, 5, 10 )
P1 = ACQN ( 4, 6, 10 )
P23 = ACQN ( 4, 7, 10 )
P4 = ACQN ( 4, 8, 10 )
RPM = SCANR ( 8, 17, 2 )
PRAR0 = SCANR ( 8, 25, 1 )
XIMC = SCANR ( 8, 32, 1 )
YAWC = SCANR ( 8, 33, 1 )
XIMA = SCANR ( 8, 34, 1 )
YAWA = SCANR ( 8, 35, 1 )
XIMR = SCANR ( 8, 36, 1 )
YAWR = SCANR ( 8, 37, 1 )
PREF = SCANR ( 8, 39, 1 )
E = SCANR ( 15, 19, 1 )
DE = SCANR ( 15, 19, 1 )
DCA = SCANR ( 15, 20, 1 )
DCB = SCANR ( 15, 20, 1 )
DATA(1, J) = TARE2
DATA(1, J+1) = PCAL
DATA(1, J+2) = P1
DATA(1, J+3) = P23
DATA(1, J+4) = P4
DATA(1, J+5) = RPM
DATA(1, J+6) = PRAR0
DATA(1, J+7) = XIMC
DATA(1, J+8) = YAWC
DATA(1, J+9) = XIMA
DATA(1, J+0) = YAWA

```

Figure H-2. Listing of Data Acquisition Program &ABKUL.
(Continued on next page.)

```

0159      DATA(1,J+10) = YAWA
0160      DATA(1,J+11) = XIMB
0161      DATA(1,J+12) = YAWB
0162      DATA(1,J+13) = PREF
0163      DATA(1,J+14) = E
0164      DATA(1,J+15) = DE
0165      DATA(1,J+16) = DCA
0166      DATA(1,J+17) = DCR
0167      WRITE (LI,105) XIMC,YAWC,P1,P23,P4,I,XIMA,YAWA,DCA,PREF,E,XIMB,
0168      *YAWB,DCR,RPM,DE
0169      IF ( LD .NE. 0 ) WRITE (LD,105) XIMC,YAWC,P1,P23,P4,I,XIMA,YAWA,DC
0170      *A,PREF,E,XIMB,YAWB,DCR,RPM,DE
0171      IF ( J .EQ. 41 ) GOTO 05
0172      IF ( J .EQ. 141 ) GOTO 10
0173      04 WRITE (LI,106)
0174      READ (LI,149) IDUM
0175      WRITE (LI,149) ( ICLR,I1=1,3)
0176      IF ( IDUM .NE. 2MGO ) GOTO 04
0177      J = J + 20
0178      I = I + 1
0179      GOTO 03
0180      05 WRITE (LI,107)
0181      READ (LI, 8) YAWP
0182      YAWP = YAWP * 2
0183      C
0184      C
0185      C
0186      C
0187      C
0188      C
0189      WRITE (LI,108)
0190      IF ( LD .NE. 0 ) WRITE (LD,108)
0191      WRITE (LI,104)
0192      IF ( LD .NE. 0 ) WRITE (LD,104)
0193      DO 09 J1 = 2,YAWP,2
0194      JJ = J1 / 2
0195      06 WRITE (LI,109) JJ
0196      READ (LI,149) IDUM
0197      WRITE (LI,149) ( ICLR,I1=1,3)
0198      IF ( IDUM .NE. 2MGO ) GOTO 06
0199      AVRGA = 0.0
0200      ICOUNT = 0
0201      START = 256
0202      STOP = 256 + 256
0203      DO 61 I1 = START,STOP,1
0204      ICOUNT = ICOUNT + 1
0205      IRLADE = I1 + 100000H
0206      CALL EXEC (3,19)
0207      CALL EXEC (1,19,IRPM,1,IRLADE)
0208      CALL EXEC (1,20,IRUFF,30,0,0)
0209      RBUFF = 0.0
0210      DO 62 J1 = 1,30,1
0211      IRUFF(J1) = IAND(IRUFF(J1),MASK)
0212      RBUFF = FLDAT ( IRUFF(J1) ) / 32768. + RBUFF
0213      62 DATA(J1,ICOUNT) = ((RBUFF*F5ULTG)/30)
0214      AVRGA = AVRGA + DATA (J1,ICOUNT)
0215      61 CONTINUE
0216      AVRGA = AVRGA / 256
0217      C
0218      C
0219      C
0220      C
0221      C
0222      C
0223      C
0224      C
0225      C
0226      C
0227      C
0228      C
0229      C
0230      C
0231      C
0232      C
0233      C
0234      C
0235      C
0236      C
0237      C
0238      C
0239      C
0240      C
0241      C
0242      C
0243      C
0244      C
0245      C
0246      C
0247      C
0248      C
0249      C
0250      C
0251      C
0252      C
0253      C
0254      C
0255      C
0256      C
0257      C
0258      C
0259      C
0260      C
0261      C
0262      C
0263      C
0264      C
0265      C
0266      C
0267      C
0268      C
0269      C
0270      C
0271      C
0272      C
0273      C
0274      C
0275      C
0276      C
0277      C
0278      C
0279      C
0280      C
0281      C
0282      C
0283      C
0284      C
0285      C
0286      C
0287      C
0288      C
0289      C
0290      C
0291      C
0292      C
0293      C
0294      C
0295      C
0296      C
0297      C
0298      C
0299      C
0300      C
0301      C
0302      C
0303      C
0304      C
0305      C
0306      C
0307      C
0308      C
0309      C
0310      C
0311      C
0312      C
0313      C
0314      C
0315      C
0316      C
0317      C
0318      C
0319      C
0320      C
0321      C
0322      C
0323      C
0324      C
0325      C
0326      C
0327      C
0328      C
0329      C
0330      C
0331      C
0332      C
0333      C
0334      C
0335      C
0336      C
0337      C
0338      C
0339      C
0340      C
0341      C
0342      C
0343      C
0344      C
0345      C
0346      C
0347      C
0348      C
0349      C
0350      C
0351      C
0352      C
0353      C
0354      C
0355      C
0356      C
0357      C
0358      C
0359      C
0360      C
0361      C
0362      C
0363      C
0364      C
0365      C
0366      C
0367      C
0368      C
0369      C
0370      C
0371      C
0372      C
0373      C
0374      C
0375      C
0376      C
0377      C
0378      C
0379      C
0380      C
0381      C
0382      C
0383      C
0384      C
0385      C
0386      C
0387      C
0388      C
0389      C
0390      C
0391      C
0392      C
0393      C
0394      C
0395      C
0396      C
0397      C
0398      C
0399      C
0400      C
0401      C
0402      C
0403      C
0404      C
0405      C
0406      C
0407      C
0408      C
0409      C
0410      C
0411      C
0412      C
0413      C
0414      C
0415      C
0416      C
0417      C
0418      C
0419      C
0420      C
0421      C
0422      C
0423      C
0424      C
0425      C
0426      C
0427      C
0428      C
0429      C
0430      C
0431      C
0432      C
0433      C
0434      C
0435      C
0436      C
0437      C
0438      C
0439      C
0440      C
0441      C
0442      C
0443      C
0444      C
0445      C
0446      C
0447      C
0448      C
0449      C
0450      C
0451      C
0452      C
0453      C
0454      C
0455      C
0456      C
0457      C
0458      C
0459      C
0460      C
0461      C
0462      C
0463      C
0464      C
0465      C
0466      C
0467      C
0468      C
0469      C
0470      C
0471      C
0472      C
0473      C
0474      C
0475      C
0476      C
0477      C
0478      C
0479      C
0480      C
0481      C
0482      C
0483      C
0484      C
0485      C
0486      C
0487      C
0488      C
0489      C
0490      C
0491      C
0492      C
0493      C
0494      C
0495      C
0496      C
0497      C
0498      C
0499      C
0500      C
0501      C
0502      C
0503      C
0504      C
0505      C
0506      C
0507      C
0508      C
0509      C
0510      C
0511      C
0512      C
0513      C
0514      C
0515      C
0516      C
0517      C
0518      C
0519      C
0520      C
0521      C
0522      C
0523      C
0524      C
0525      C
0526      C
0527      C
0528      C
0529      C
0530      C
0531      C
0532      C
0533      C
0534      C
0535      C
0536      C
0537      C
0538      C
0539      C
0540      C
0541      C
0542      C
0543      C
0544      C
0545      C
0546      C
0547      C
0548      C
0549      C
0550      C
0551      C
0552      C
0553      C
0554      C
0555      C
0556      C
0557      C
0558      C
0559      C
0560      C
0561      C
0562      C
0563      C
0564      C
0565      C
0566      C
0567      C
0568      C
0569      C
0570      C
0571      C
0572      C
0573      C
0574      C
0575      C
0576      C
0577      C
0578      C
0579      C
0580      C
0581      C
0582      C
0583      C
0584      C
0585      C
0586      C
0587      C
0588      C
0589      C
0590      C
0591      C
0592      C
0593      C
0594      C
0595      C
0596      C
0597      C
0598      C
0599      C
0600      C
0601      C
0602      C
0603      C
0604      C
0605      C
0606      C
0607      C
0608      C
0609      C
0610      C
0611      C
0612      C
0613      C
0614      C
0615      C
0616      C
0617      C
0618      C
0619      C
0620      C
0621      C
0622      C
0623      C
0624      C
0625      C
0626      C
0627      C
0628      C
0629      C
0630      C
0631      C
0632      C
0633      C
0634      C
0635      C
0636      C
0637      C
0638      C
0639      C
0640      C
0641      C
0642      C
0643      C
0644      C
0645      C
0646      C
0647      C
0648      C
0649      C
0650      C
0651      C
0652      C
0653      C
0654      C
0655      C
0656      C
0657      C
0658      C
0659      C
0660      C
0661      C
0662      C
0663      C
0664      C
0665      C
0666      C
0667      C
0668      C
0669      C
0670      C
0671      C
0672      C
0673      C
0674      C
0675      C
0676      C
0677      C
0678      C
0679      C
0680      C
0681      C
0682      C
0683      C
0684      C
0685      C
0686      C
0687      C
0688      C
0689      C
0690      C
0691      C
0692      C
0693      C
0694      C
0695      C
0696      C
0697      C
0698      C
0699      C
0700      C
0701      C
0702      C
0703      C
0704      C
0705      C
0706      C
0707      C
0708      C
0709      C
0710      C
0711      C
0712      C
0713      C
0714      C
0715      C
0716      C
0717      C
0718      C
0719      C
0720      C
0721      C
0722      C
0723      C
0724      C
0725      C
0726      C
0727      C
0728      C
0729      C
0730      C
0731      C
0732      C
0733      C
0734      C
0735      C
0736      C
0737      C
0738      C
0739      C
0740      C
0741      C
0742      C
0743      C
0744      C
0745      C
0746      C
0747      C
0748      C
0749      C
0750      C
0751      C
0752      C
0753      C
0754      C
0755      C
0756      C
0757      C
0758      C
0759      C
0760      C
0761      C
0762      C
0763      C
0764      C
0765      C
0766      C
0767      C
0768      C
0769      C
0770      C
0771      C
0772      C
0773      C
0774      C
0775      C
0776      C
0777      C
0778      C
0779      C
0780      C
0781      C
0782      C
0783      C
0784      C
0785      C
0786      C
0787      C
0788      C
0789      C
0790      C
0791      C
0792      C
0793      C
0794      C
0795      C
0796      C
0797      C
0798      C
0799      C
0800      C
0801      C
0802      C
0803      C
0804      C
0805      C
0806      C
0807      C
0808      C
0809      C
0810      C
0811      C
0812      C
0813      C
0814      C
0815      C
0816      C
0817      C
0818      C
0819      C
0820      C
0821      C
0822      C
0823      C
0824      C
0825      C
0826      C
0827      C
0828      C
0829      C
0830      C
0831      C
0832      C
0833      C
0834      C
0835      C
0836      C
0837      C
0838      C
0839      C
0840      C
0841      C
0842      C
0843      C
0844      C
0845      C
0846      C
0847      C
0848      C
0849      C
0850      C
0851      C
0852      C
0853      C
0854      C
0855      C
0856      C
0857      C
0858      C
0859      C
0860      C
0861      C
0862      C
0863      C
0864      C
0865      C
0866      C
0867      C
0868      C
0869      C
0870      C
0871      C
0872      C
0873      C
0874      C
0875      C
0876      C
0877      C
0878      C
0879      C
0880      C
0881      C
0882      C
0883      C
0884      C
0885      C
0886      C
0887      C
0888      C
0889      C
0890      C
0891      C
0892      C
0893      C
0894      C
0895      C
0896      C
0897      C
0898      C
0899      C
0900      C
0901      C
0902      C
0903      C
0904      C
0905      C
0906      C
0907      C
0908      C
0909      C
0910      C
0911      C
0912      C
0913      C
0914      C
0915      C
0916      C
0917      C
0918      C
0919      C
0920      C
0921      C
0922      C
0923      C
0924      C
0925      C
0926      C
0927      C
0928      C
0929      C
0930      C
0931      C
0932      C
0933      C
0934      C
0935      C
0936      C
0937      C
0938      C
0939      C
0940      C
0941      C
0942      C
0943      C
0944      C
0945      C
0946      C
0947      C
0948      C
0949      C
0950      C
0951      C
0952      C
0953      C
0954      C
0955      C
0956      C
0957      C
0958      C
0959      C
0960      C
0961      C
0962      C
0963      C
0964      C
0965      C
0966      C
0967      C
0968      C
0969      C
0970      C
0971      C
0972      C
0973      C
0974      C
0975      C
0976      C
0977      C
0978      C
0979      C
0980      C
0981      C
0982      C
0983      C
0984      C
0985      C
0986      C
0987      C
0988      C
0989      C
0990      C
0991      C
0992      C
0993      C
0994      C
0995      C
0996      C
0997      C
0998      C
0999      C
1000      C

```

Figure H-2. Listing of Data Acquisition Program &ABKUL. (Continued on next page.)

```

0239          AVRCB          = AVRCB / 256
0240 C      DO 5455 I = 1, 32, 1
0241          WRITE (6, 1313) (J, DATA(JI+1, J), J = 1, 256, 32)
0242          WRITE (1, 333) AVRCB
0243          333 FORMAT('4 AVRCB = 'F12.6)
0244
0245          .....
0246          Get necessary steady state data
0247          .....
0248          GOTO 099
0249          .....
0250          I = (JJ - 1) * 20 + 1
0251          DATA(20, I+1) = ACQN ( 4, 1, 10)
0252          DATA(20, I+2) = ACQN ( 4, 2, 10)
0253          DATA(20, I+3) = ACQN ( 4, 3, 10)
0254          DATA(20, I+4) = ACQN ( 4, 4, 10)
0255          DATA(20, I+5) = SCANR ( 8, 17, 1)
0256          DATA(20, I+6) = SCANR ( 8, 25, 1)
0257          DATA(20, I+7) = SCANR ( 8, 32, 1)
0258          DATA(20, I+8) = SCANR ( 8, 33, 1)
0259          DATA(20, I+9) = SCANR ( 8, 34, 1)
0260          DATA(20, I+10) = SCANR ( 8, 35, 1)
0261          DATA(20, I+11) = SCANR ( 8, 35, 1)
0262          DATA(20, I+12) = SCANR ( 8, 37, 1)
0263          DATA(20, I+13) = SCANR ( 8, 39, 1)
0264          DATA(20, I+14) = SCANR (15, 10, 1)
0265          DATA(20, I+15) = SCANR (15, 19, 1)
0266          DATA(20, I+16) = SCANR (15, 22, 1)
0267          DATA(20, I+17) = SCANR (15, 23, 1)
0268          DATA(20, I+18) = AVRCB
0269          DATA(20, I+19) = AVRCB
0270          WRITE (1, 105) DATA(20, I+7), DATA(20, I+8), DATA(20, I+2), DATA(20, I+3)
0271          * DATA(20, I+4), JJ, DATA(20, I+9), DATA(20, I+10), DATA(20, I+16),
0272          * DATA(20, I+13), DATA(20, I+14), DATA(20, I+11), DATA(20, I+12),
0273          * DATA(20, I+17), DATA(20, I+5), DATA(20, I+15)
0274          WRITE (1, 112) AVRCB, AVRCB
0275          IF ( LO .NE. 0 ) WRITE (10, 105) DATA(20, I+7), DATA(20, I+8), DATA(20,
0276          * I+2), DATA(20, I+3), DATA(20, I+4), JJ, DATA(20, I+9), DATA(20, I+10), DATA
0277          * (20, I+16), DATA(20, I+13), DATA(20, I+14), DATA(20, I+11), DATA(20, I+12),
0278          * DATA(20, I+17), DATA(20, I+5), DATA(20, I+15)
0279          IF ( LO .NE. 0 ) WRITE (10, 112) AVRCB, AVRCB
0280          .....
0281          Next yaw position.
0282          .....
0283          09 CONTINUE
0284          J = 81
0285          GOTO 02
0286          10 CONTINUE
0287          .....
0288          Release interface bus and devices from remote control
0289          .....
0290          CALL CLEAR (7, 1)
0291          CALL LOCL (7)
0292          .....
0293          DO 11 I = 1, 4, 1
0294          J = (I-1) * 20 + 17
0295          X(I) = DATA(1, J)
0296          JJ = J - 3
0297          11 Y(I) = DATA(1, JJ)
0298          CALL CURVE (4, X, Y, SLOPE, SECON)
0299          DATA(1, 160) = SLOPE
0300          DATA(1, 161) = SECON
0301          DO 12 I = 1, 4, 1
0302          J = (I-1) * 20 + 18
0303          X(I) = DATA(1, J)
0304          JJ = J - 4
0305          12 Y(I) = DATA(1, JJ)
0306          CALL CURVE (4, X, Y, SLOPE, SECON)
0307          DATA(1, 170) = SLOPE
0308          DATA(1, 171) = SECON
0309          DO 13 I = 1, 4, 1
0310          J = (I-1) * 20 + 9
0311          X(I) = DATA(1, J)
0312          JJ = J - 2
0313          13 Y(I) = DATA(1, JJ)
0314
0315
0316
0317

```

Figure H-2. Listing of Data Acquisition Program &ABKUL.
(Continued on next page.)

```

0319      CALL CURVE (4, X, Y, SLOPE, SECON)
0320      DATA(1,180) = SLOPE
0321      DATA(1,181) = SECON
0322      DO 14 I = 1, 4, 1
0323      J
0324      = (I-1) * 20 + 98
0325      X(I)
0326      = DATA(1, J)
0327      JJ
0328      = DATA(1, JJ)
14      CALL CURVE (4, X, Y, SLOPE, SECON)
0329      DATA(1,190) = SLOPE
0330      DATA(1,191) = SECON
0331      WRITE (LI,110) ( DATA(1,I), DATA(1,I+1), I = 160,190,10)
0332      IF (LO.NE.0) WRITE(LO,110) ( DATA(1,I), DATA(1,I+1), I = 160,190,10)
0333      WRITE (LI,111)
0334      READ (LI,149) IFILE
0335      CALL CREAT (IDCB,IERR,IFILE,ISIZE,ITYPE,ISECU,ICR,IDCBS)
0336      II = 1
0337      IF ( IERR .LT. 0 ) WRITE (1,1111) II,IERR
0338      CALL OPEN (IDCB,IERR,IFILE,IOPTR,ISECU,ICR,IDCBS)
0339      II = 2
0340      IF ( IERR .LT. 0 ) WRITE (1,1111) II,IERR
0341      CALL WRITF (IDCB,IERR,DATA,IL)
0342      II = 3
0343      IF ( IERR .LT. 0 ) WRITE (1,1111) II,IERR
0344      CALL CLOSE (IDCB,IERR,0)
0345      II = 4
0346      IF ( IERR .LT. 0 ) WRITE (1,1111) II,IERR
0347      STOP 7777
      END

```

Figure H-2. Listing of Data Acquisition Program &ABKUL.

APPENDIX I

PROCESSING PROGRAMS &SPLIT AND &WAVE FOR TEST DATA

As stated in 6.3 a plot of the acquired high speed data is very desirable since it represents the fastest way to judge the quality of the data. As the graphics software requires much storage space within a program, it is not possible to read the complete data file into a plot program. A utility program--&SPLIT--has been created which splits the data array into two smaller arrays containing either A or B probe data. These arrays contain the data for the on-line calibration and steady state also. They are both stored under different names, which are operator input.

Since program &SPLIT is a very short and simple program, only a listing is given in Fig. I-1. Explanations are given as needed within the listing. The two newly created files are stored on the same cartridge as the original raw data file.

Program &WAVE provides means to read the smaller data files and to plot their contents. If the variable POS is assigned to be the circumferential position of the probe readings where the starting position is set to 1 and the end position to 256, the pressure distribution can be expressed as a function $P = P(\text{pos})$ for all nine yaw angles. These functions can be plotted by program &WAVE. The plot is a straight line connection of all points.

As mentioned in 6.3 program &WAVE serves two purposes: plotting Kulite data from an existing file and acquiring data from any of the 16 A/D channels and plotting it right away. The decision as to which of the two options shall be used has to be made first by the operator. If it is desired to plot data from a data file, the operator has to key in the file name and the cartridge reference number. This file is then read into a data array. For each probe yaw angle setting there is one pressure distribution $P = P(\text{PCS})$ and the operator is asked to specify the one he wants to plot. The choice of plotting on the CRT screen or the X-Y plotter has to be made as well as whether a whole new frame for the plot is needed. Without further input the graph is developed. Other data from the same file can be plotted without rerunning the program or it can be stopped at this point.

If the second feature of the program should be exercised, it has to be specified at the very beginning, when asked for this decision. An A/D channel number has to be entered which corresponds to the Kulite transducer that shall be observed. The number of samples to be taken at each of the 256 positions also has to be put in. This initializes the data acquisition process. Once all the data is acquired, the operator has to decide whether he needs a new frame or not and where he would like to have his plot (CRT or X-Y plotter). As soon as the plot is dumped, the program can either be stopped or started from the very beginning.

Figure I-2 shows a flow chart of program &WAVE, while Fig. I-3 is a listing.

<u>Variable</u>	<u>Type</u>	<u>Description</u>
AD	Integer	Dummy Variable
CHANL	Integer	A/D channel number
DATA(11,256)	Real	Data Array
FSVLTG	Real	Calibration factor for Kulite probe reading
IBUFF(99)	Integer	Array for Kulite sample values
IBUM	Integer	Dummy variable
ICR	Integer	Cartridge reference number
ID	Integer	
IDCB(144)	Integer	Data control block
IDCBS	Integer	Data control block length
IDUM	Integer	Dummy variable
IFILE(3)	Integer	Array containing file name
IGCB(192)	Integer	Graphics control block
IL	Integer	Total number of words stored in data file (two words for one value)
ISECU	Integer	Security code
ISIZE(2)	Integer	Array to specify file dimensions
ITYPE	Integer	Type of data file
LI	Integer	Input device number
LU	Integer	Output device (screen/plotter) number
MASK	Integer	Masking variable
N	Integer	Number of samples to be averaged

<u>Variable</u>	<u>Type</u>	<u>Description</u>
RBUFF	Real	Real value of single sample
RBUFO	Real	Sum of all real value samples for one position
X(256)	Real	Real data array
Y(256)	Real	Real data array

ASPLIT T=00004 IS DN CR00026 UCING 00021 BLKS R=0000

```
0001 FTN4,L
0002 PROGRAM SPLIT(3,99)
0003 .....
0004 .....
0005 ..... This program splits the large data file as created by program
0006 ..... ARKUL into two separate data files.
0007 ..... One contains the waveforms of the A-probe and the other the
0008 ..... one from the B-probe!
0009 .....
0010 .....
0011 REAL DATA(20,256),DATA(11,256)
0012 INTEGER IDC(144),IFILE(3),IC(2)
0013 DATA IDERS / 144/
0014 DATA ISECU / 00/
0015 DATA ITYPE / 1/
0016 DATA IC(2) / 128/
0017 101 FORMAT(" ENTER THE NAME OF THE RAW DATA FILE : ")
0018 102 FORMAT(" ENTER THE CARTRIDGE REFERENCE NUMBER : ")
0019 103 FORMAT(" ENTER THE NAME FOR THE FILE CONTAINING A-PROBE DATA")
0020 104 FORMAT(" ENTER THE NAME FOR THE FILE CONTAINING B-PROBE DATA")
0021 149 FORMAT("A")
0022 1111 FORMAT(" STATEMENT # : *12* ERROR # : *14* DISCOVERED!")
0023 ISIZE(1) = 80
0024 IL = 10240
0025 .....
0026 .....
0027 READ RAW DATA FILE INTO ARRAY DATA(20,256) !
0028 .....
0029 .....
0030 WRITE (1,101)
0031 READ (1,149) IFILE
0032 WRITE (1,102)
0033 READ (1,*) ICR
0034 CALL OPEN (IDC,IERR,IFILE,IOPIN,ISECU,ICR,IDCS)
0035 JJ = 1
0036 IF ( IERR .LT. 0 ) WRITE (1,1111) JJ,IERR
0037 CALL READF (IDC,IERR,DATA,IL,LEN,1)
0038 JJ = 2
0039 IF ( IERR .LT. 0 ) WRITE(1,1111) JJ,IERR
0040 CALL CLOSE (IDC,IERR,0)
0041 JJ = 3
0042 IF ( IERR .LT. 0 ) WRITE(1,1111) JJ,IERR
0043 .....
0044 .....
0045 READ A-PROBE DATA INTO SEPARATE ARRAY
0046 .....
0047 .....
0048 .....
0049 DO 05 I = 1,256,1
0050 DU 05 I = 1,256,1
0051 JA = I * 4
0052 JB = I * 4
0053 DATA(JA,1) = DATA(JJ,1)
0054 DATA(JB,1) = DATA(JJ,1)
0055 DO 05 I = 44
0056 ISIZE(1) = 44
0057 IL = 5632
0058 .....
0059 .....
0060 READ FILENAME FOR A-PROBE DATA AND STORE A-PROBE DATA
0061 .....
0062 .....
0063 .....
0064 WRITE (1,103)
0065 READ (1,149) IFILE
0066 CALL CREAT (IDC,IERR,IFILE,ISIZE,ITYPE,ISECU,ICR,IDCS)
0067 JJ = 4
0068 IF ( IERR .LT. 0 ) WRITE(1,1111) JJ,IERR
0069 CALL OPEN (IDC,IERR,IFILE,IOPIN,ISECU,ICR,IDCS)
0070 JJ = 1
0071 IF ( IERR .LT. 0 ) WRITE(1,1111) JJ,IERR
0072 CALL WRITE (IDC,IERR,DATA,10)
0073 JJ = 2
0074 IF ( IERR .LT. 0 ) WRITE(1,1111) JJ,IERR
0075 CALL CLOSE (IDC,IERR,0)
0076 IF ( IERR .LT. 0 ) WRITE(1,1111) JJ,IERR
```

Figure I-1. Listing Program to Split Up Big Raw Data Array From A-B Probe Into Smaller Arrays: &SPLIT. (Continued on next page.)

```

0079          CCCC          : READ B-PROBE DATA INTO SEPARATE ARRAY .
0080          :
0081          :
0082          :
0083          DD 07          J = 1, 9, 1
0084          DD 07          I = 1, 256, 1
0085          J1           = ( J + 2 ) + 1
0086          J2           = J + 1
0087          DATAS(J2,I) = DATA(J1,I)
0088          DATAS(1,I)  = DATA(1,I)
0089          DATAS(11,I) = DATA(20,I)
0090          :
0091          :
0092          : READ FILENAME FOR B-PROBE DATA AND STORE B-PROBE DATA.
0093          :
0094          :
0095          WRITE (1,104)
0096          READ (1,149) IFILE
0097          CALL CREAT (IDCB,IERR,IFILE,ISIZE,ITYPE,ISECU,ICR,IDCBS)
0098          JJ = 7
0099          IF (IERR .LT. 0 ) WRITE(1,1111) JJ,IERR
0100          CALL OPEN (IDCB,IERR,IFILE,IOPTR,ISECU,ICR,IDCBS)
0101          JJ = 8
0102          IF (IERR .LT. 0 ) WRITE(1,1111) JJ,IERR
0103          CALL WRITE (IDCB,IERR,DATAS,IL)
0104          JJ = 9
0105          IF (IERR .LT. 0 ) WRITE(1,1111) JJ,IERR
0106          CALL CLOSE (IDCB,IERR,0)
0107          JJ = 10
0108          IF (IERR .LT. 0 ) WRITE(1,1111) JJ,IERR
0109          STOP 7777
0110          END

```

Figure I-1. Listing of Program to Split Up Big Raw Data Array From A-B Probe Into Two Smaller Arrays: &SPLIT.

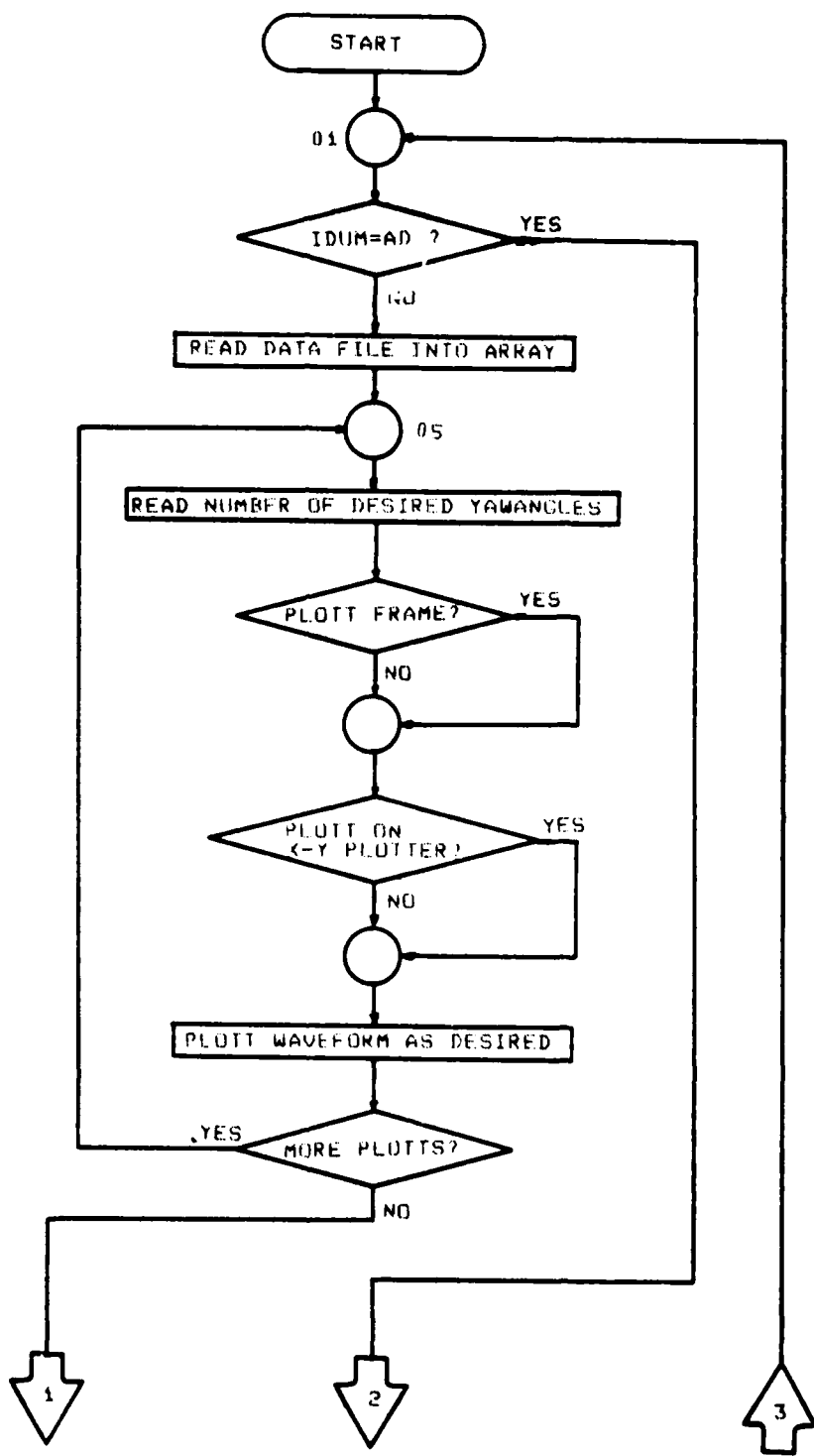

Figure I-2. Flow Chart of Data Acquisition and Plotter Program &WAVE.

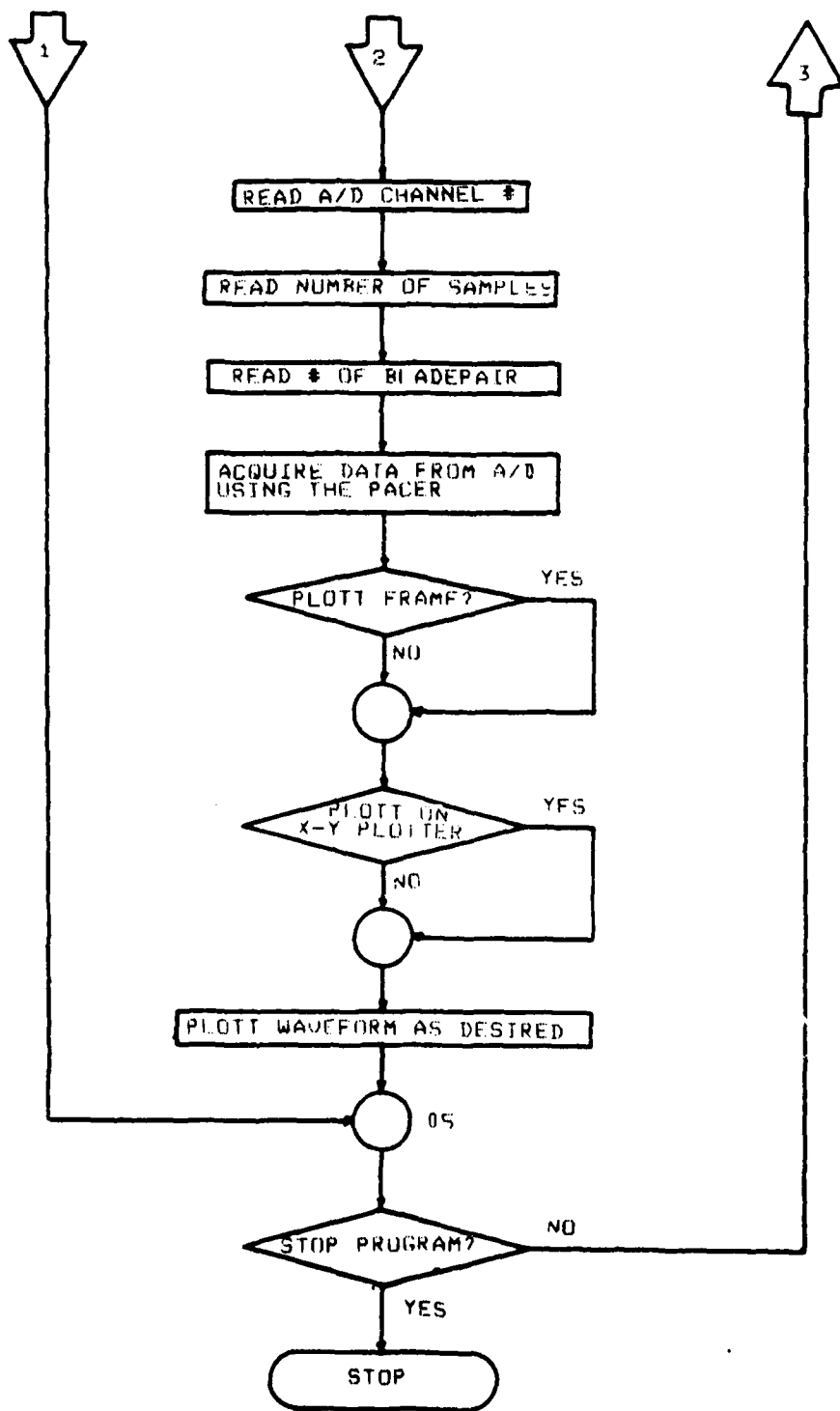

Figure I-2. Flow Chart of Data Acquisition and Plotter Program &WAVE.

&WAVE T=00004 IS DN CR00027 USING 00022 BLKS R=0000

```

0001 FTN4,L
0002 PROGRAM WAVE (3,99)
0003 .....
0004 .....
0005 .....
0006 .....
0007 .....
0008 .....
0009 .....
0010 .....
0011 DIMENSION ICRB(192),IBUFF(99)
0012 REAL DATA(11,256),X(256),Y(256)
0013 INTEGER IDCRC(144),IFILE(3),ISIZE(2),N,CHANL
0014 DATA IDCRC // 144/
0015 DATA ISECU // 00/
0016 DATA ITYPE // 1/
0017 DATA IL // 5632/
0018 DATA ISIZE(1) // 44/
0019 DATA ISIZE(2) // 128/
0020 DATA MASK // 177700B/
0021 DATA FSVLTG // .1E01/
0022
0023 100 FORMAT (" This is program WAVE. /* If can plott a waveform as read
0024 * from the AD or from a data file. /* Decide now, which of the two
0025 * options you want! /* Key AD if you want to take a new reading. An
0026 * anything else /* will ask for further informations for a data file.")
0027 101 FORMAT ("Enter the name of the data file!")
0028 102 FORMAT ("Enter the cartridge ref. number!")
0029 103 FORMAT(" Do you want another waveform to be plottet?/* Enter yes,
0030 * if so, anything else if not!")
0031 104 FORMAT(" Do you want to stop this program or plot some more waves?
0032 * /* If you are going to stop it, just key STOP. Anything else will
0033 * give you further instructions!")
0034 105 FORMAT (/12X,5(2X,F10.6)/5X,I2,5X,5(2X,F10.6)/12X,5(2X,F10.6))
0035 107 FORMAT(" Do you need a complete new frame?/* Answer YES or NO!")
0036 108 FORMAT(" If you want the plott on the plottor, key PL, anything else
0037 * for the terminal!")
0038 113 FORMAT(" You decided to to get a waveform from the AD!/*Enter the
0039 * following now : AD channel")
0040 114 FORMAT(" Number of repetitions, blndepair (1-9) :")
0041 115 FORMAT(" Enter the corresponding number for the waveform you want
0042 * to draw!/* The arrangement is: /* You pos # 1 2
0043 * 3 9 /*9X" DATA( 1,J), DATA(2,J), DATA(3,J), ...
0044 * DATA( 9,J) - Probe")
0045 116 FORMAT(" Do you want a plot of another waveform?/* If so, key YE.
0046 * Any other key will stop the program!")
0047 149 FORMAT ("362")
0048 1111 FORMAT (" STATEMENT # : "I3" ERROR # : "I4" DETECTED")
0049 LI = LOGU(ISESSN)
0050 001 WRITE (LI,100)
0051 READ (LI,149) IDUM
0052 IF ( IDUM .EQ. 2HAD ) GOTO 025
0053 WRITE (LI,101)
0054 READ (LI,149) IFILE
0055 WRITE (LI,102)
0056 READ (LI, *) ICR
0057 CALL OPEN (IDCR,IERR,IFILE,IOPTN,ISECU,ICR,IDCRS)
0058 JJ = 1
0059 IF (IERR .LT. 0 ) WRITE (LI,1111) JJ,IERR
0060 CALL READF (IDCR,IERR,DATA,IL,LEN,1)
0061 JJ = 2
0062 IF (IERR .LT. 0 ) WRITE (LI,1111) JJ,IERR
0063 JJ = 3
0064 CALL CLOSE (IDCR,IERR,0)
0065 IF (IERR .LT. 0 ) WRITE (LI,1111) JJ,IERR
0066 005 WRITE (LI,115)
0067 READ (LI, *) I
0068 II = I + 1
0069 DO 010 J = 1,256,1
0070 X(J) = J * XW
0071 Y(J) = DATA(II,J)
0072 LU = 1
0073 ID = 1
0074 WRITE (LI,107)
0075 READ (LI,149) IDUM
0076 WRITE (LI,108)
0077 READ (LI,149) IBUM
0078

```

Figure I-3. Listing of Program to Plott Raw Data Waveforms: &WAVE.
(Continued on next page.)

```

0079      IF (IDUM .EQ. 2MPL ) ID = 2
0080      IF (ID .EQ. 2 ) LU = 13
0081      CALL PLOTR (IGCB, ID, LU)
0082      CALL SETAR (IGCB, 1, 5)
0083      CALL VIEWP (IGCB, 20, 100, 20, 68.)
0084      CALL WINDW (IGCB, 0, 256, -1.0, 1.0)
0085      IF ( IDUM .NE. 2MVE ) GOTO 015
0086      CALL FXD (IGCB, 2)
0087      CALL LGRID (IGCB, -16., 10, 0.0, 0.0, 4., 2., 1.)
0088
0089 015  CALL MOVE (IGCB, X(1), Y(1))
0090      DO 020 J = 2, 256, 1
0091 020  CALL DRAW (IGCB, X(J), Y(J))
0092      WRITE (LI, 103)
0093      READ (LI, 149) IDUM
0094      IF ( IDUM .EQ. 2MVE ) GOTO 05
0095      GOTO 050
0096 025  WRITE (LI, 113)
0097      READ (LI, *) ICHAN
0098      WRITE (LI, 114)
0099      READ (LI, *) N, IBLADE
0100      ISTART = (IBLADE-1) * 256 + 1
0101      ISTOP = ISTART + 255
0102      I1 = 0
0103      DO 035 I = ISTART, ISTOP, 1
0104      I1 = I1 + 1
0105      IBLADE = I + 256 + 1000008
0106      CALL EXEC (3, 19)
0107      CALL EXEC (1, 19, IRPM, 1, IBLADE)
0108      CALL EXEC (1, 20, IBUFF, N, ICHAN, 0)
0109      RBUFO = 0.0
0110      DO 030 J = 1, N, 1
0111      IBUFF(J) = 1 AND (IBUFF(J), MASK)
0112      RBUFF(J) = FLOAT (IBUFF(J)) / 32768.
0113 030  RBUFO = RBUFO + RBUFF
0114 035  Y(I1) = ((RBUFO * RSVLTC) / N)
0115      LU = 1
0116      ID = 1
0117      WRITE (LI, 107)
0118      READ (LI, 149) IDUM
0119      WRITE (LI, 108)
0120      READ (LI, 149) IDUM
0121      IF (IDUM .EQ. 2MPL ) ID = 2
0122      IF (ID .EQ. 2 ) LU = 13
0123      CALL PLOTR (IGCB, ID, LU)
0124      CALL SETAR (IGCB, 1, 5)
0125      CALL VIEWP (IGCB, 20, 100, 20, 68.)
0126      CALL WINDW (IGCB, 0, 256, -1.0, 1.0)
0127      IF ( IDUM .NE. 2MVE ) GOTO 040
0128      CALL FXD (IGCB, 2)
0129      CALL LGRID (IGCB, -16., 10, 0.0, 0.0, 4., 2., 1.)
0130
0131 040  CONTINUE
0132      CALL MOVE (IGCB, 1, Y(1))
0133      DO 045 J = 2, 256, 1
0134      X(J) = J * 1.0
0135 045  CALL DRAW (IGCB, X(J), Y(J))
0136
0137 050  WRITE (LI, 104)
0138      READ (LI, 149) IDUM
0139      IF ( IDUM .NE. 2MST ) GOTO 01
0140      STOP 7777
      END

```

Figure I-3. Listing of Program to Plott Raw Data Waveforms: &WAVE.

APPENDIX J

DATA REDUCTION PROGRAM &ABRED

Program &ABRED was explained almost completely in chapter 6.4. More detailed explanations shall be given in here where they are needed. Figure J-1 shows a self-explanatory flow chart of the program while Fig. J-2 is a complete listing.

From the flow chart it is obvious that the first and bigger part of the program deals with overall flow measurements from the combination probe. The data reduction of these measurements is not explained since Ref. 1 deals with this in great detail. It should be mentioned that the raw data used for the combination probe data reduction is the average of the raw data which was acquired along with the acquisition of any set of Kulite probe data. Thus the results of the combination probe represent one average flow vector which is assumed to be constant throughout the data acquisition process. As the Kulite data used for the on-line calibration is derived from the whole raw data acquired also, this seems to be a reasonable way. The principle of the on-line calibration was described in chapter 6.1 already. If a print-out of the control parameters was chosen, the result of the on-line calibration will be displayed in the form of a linear equation relating A and B probe pressures to voltages.

The results of the on-line calibration are first applied to the dc-level values from the A and B probe in order to calculate the average flow vector. Chapter 6.4 shows the results of this process. The procedure used to derive these values is in principal the same as the one used to calculate flow vector quantities for the individual measurements. In order to check the quality of the data reduction, an output of the A and B probe results as derived from their approximations can be produced. The yaw and pitch angle as well as Mach number are derived from the approximation results and printed out. These values can be compared to those derived from the combination probe (see 6.4).

Then the DO-loop for the reduction of individual data points is started at the position (ISTART) determined earlier. For any of these positions the results of the on-line calibration is applied to the raw data first, so that absolute pressure values exist. The data reduction procedure as described in 6.4 is then applied to these values. Using the local Mach number as well as the total pressure as derived from the A probe, pressure coefficients C_{p_A} are derived as functions of yaw angle and can be printed if desired. The examination of these values proved to be very helpful in the evaluation of the quality of the achieved result.

Since the A probe has only one calibration curve C_{p_A} as a function of yaw angle, as long as the pitch angle and Mach number do not exceed the range of the calibration, for any

measured position the same curve should be resolved. The use made of this fact so far is described in chapter 7.

When the DO-loop for all described positions is completed, the reduced data is stored in a file. Only pitch and yaw angle and Mach number (or x) are stored, since they are sufficient to describe the individual flow vectors.

<u>Common Block Identifier</u>	<u>Variable</u>
DTA2	X1, Y

<u>Variable</u>	<u>Type</u>	<u>Description</u>
AAO	Real	A probe yaw angle for aligned flow
ABO	Real	B probe yaw angle corresponding to max. probe output
ASL	Real	A probe yaw angle 63° left of flow aligned yaw angle
ASR	Real	A probe yaw angle 63° right of flow aligned yaw angle
BETA	Real	Dimensionless pressure coefficient
BETA2	Real	Relative rotor exit flow angle
COECPB(7,7)	Real	Data array for coefficients of 3-D CPOB approximation
COEF(7)	Real	Data array for 2-D approximation coefficients
COEKP(7,7)	Real	Data array for coefficients of 3-D Kulite pitch angle approximation
COEKX(7,7)	Real	Data array for coefficient of 3-D Kulite Mach number approximation
COEOP(7,7)	Real	Data array for coefficients of 3-D combination probe pitch angle approximation

<u>Variable</u>	<u>Type</u>	<u>Description</u>
COEOX(7,7)	Real	Data array for coefficients of 3-D combination probe Mach number approximation
CPA	Real	Pressure coefficient from A probe
CPAMAX	Real	Maximum pressure coefficient from A probe
CPBMAX	Real	Maximum pressure coefficient from B probe
CPOA(6)	Real	Data array for 2-D approximation of A probe pressure coefficients
DATA(20,256)	Real	Data array containing the raw data
DEAMAX	Real	First derivative of approximated function EA (voltage A probe) of yaw angle for maximum of EA
DEBMA	Real	First derivative of approximated function EB (voltage B probe) of yaw angle for maximum of EB
DELTA	Real	Pressure coefficient
DP	Real	Pressure difference for two pressure values corresponding to two yaw angles which are separated by DX
DPA	Real	Difference between actual A probe pressure and value derived from polynomial approximation at each yaw position.
DPB	Real	Difference between actual B probe pressure and value derived from polynomial approximation at each yaw position
DPX	Real	First derivative of the function $P_A(\alpha) - P_A(\alpha - \Delta\alpha)$
DX	Real	Given spread in yaw angle between PSAL and PSAR
EAMAX	Real	Maximum voltage from the A probe
EBMAX	Real	Maximum voltage from the B probe

<u>Variable</u>	<u>Type</u>	<u>Description</u>
EQ3	Real	CPOA - maximum pressure coefficient of A probe (used in on-line calibration)
EQ5	Real	CPOB - maximum pressure coefficient of B probe (used in on-line calibration)
GAMMA	Real	Pressure coefficient
ICR	Integer	Cartridge reference number
IDCB(144)	Integer	Data control block
IDCBS	Integer	Control block length (of IDCB)
IFILE(3)	Integer	Array containing file name
IL	Integer	Total number of words read from data file (two words for one value)
IPRINT	Integer	Decision variable (control parameters yes or no?)
IPRIN1	Integer	Decision variable (calibration coefficients yes or no?)
ISECU	Integer	Security code
ISIZE(2)	Integer	Array to specify file dimensions
ITYPE	Integer	Type of data file
ICLR(3)	Integer	Command to clear line above cursor
LI	Integer	Input device number
LO	Integer	Output device number
NOLF	Integer	No line feed command
NOCR	Integer	No carriage return command
PA(9)	Real	A probe pressure values from individual measurements
PAA(9)	Real	A probe pressure values from averaged (dc-level) measurements
PAB(9)	Real	B probe pressure values from averaged (dc-level) measurements

<u>Variable</u>	<u>Type</u>	<u>Description</u>
PAC(9)	Real	Calculated values of A probe
PAMAX	Real	Maximum pressure value of A probe output as function of yaw angle
PB(9)	Real	B probe pressure values from individual measurements
PBARO	Real	Barometric pressure
PBC	Real	Calculated values of B probe
PBMAX	Real	Maximum pressure value of B probe output as function of yaw angle
PHI	Real	Pitch angle
PKB	Real	Maximum absolute average value of B probe pressure
PREF	Real	Average value of Kulite reference pressure
PREFP(9)	Real	Array of reference pressures for all 9 independent yaw positions
PSA	Real	Static pressure equivalent of A probe
PSAL	Real	Pressure reading of A probe for a yaw angle 63° to the left of the flow aligned yaw angle
PSAR	Real	Pressure reading of A probe for a yaw angle 63° to the right of the flow aligned yaw angle
PSTAT	Real	Static pressure
PSTATA	Real	Static pressure minus Kulite reference pressure
PTOTAL	Real	Total pressure
POA	Real	Maximum pressure output of A probe (on-line calibration)
POB	Real	Maximum pressure output of B probe (on-line calibration)

AD-A136 350

FURTHER DEVELOPMENT OF A DUAL-PROBE DIGITAL SAMPLING
(DPDS) TECHNIQUE FOR..(U) BDM CORP MONTEREY CA
F NEUHOFF SEP 82 NPS-67-82-01CR N00014-79-C-0088

3/3

UNCLASSIFIED

F/G 14/2

NL

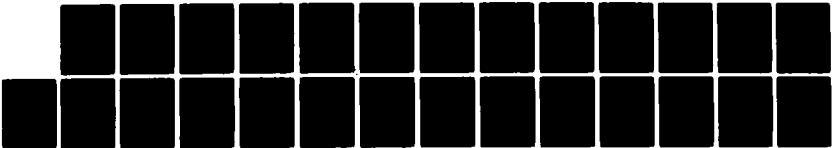

END

DATA

FILMED

2-84

DTIC

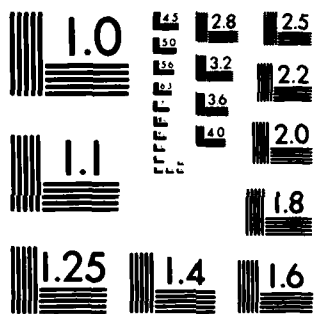

MICROCOPY RESOLUTION TEST CHART
NATIONAL BUREAU OF STANDARDS-1963-A

<u>Variable</u>	<u>Type</u>	<u>Description</u>
P1	Real	
P23	Real	Pressure values of combination probe
P4	Real	
RADIS	Real	Radius of probe tip location
RDATA(3,256)	Real	Reduced data array
RPM	Real	Compressor speed
SECTA	Real	Intercept A probe
SECTB	Real	Intercept B probe
SLOPEA	Real	Slope A probe
SLOPEB	Real	Slope B probe
TT2	Real	Total temperature at rotor exit
U	Real	Circumferential rotor speed
XM	Real	Mach number
XU	Real	Dimensionless circumferential rotor speed
XVEL	Real	Mach number equivalent dimensionless speed
X0	Real	Starting value for the iteration to find PSAL and PSAR
X1(256)	Real	Data array for 2-D approximations
Y(256)	Real	Data array for 2-D approximations
YAW	Real	Yaw angle
YAWA(9)	Real	Array containing A probe yaw angles
YAWB(9)	Real	Array containing B probe yaw angles

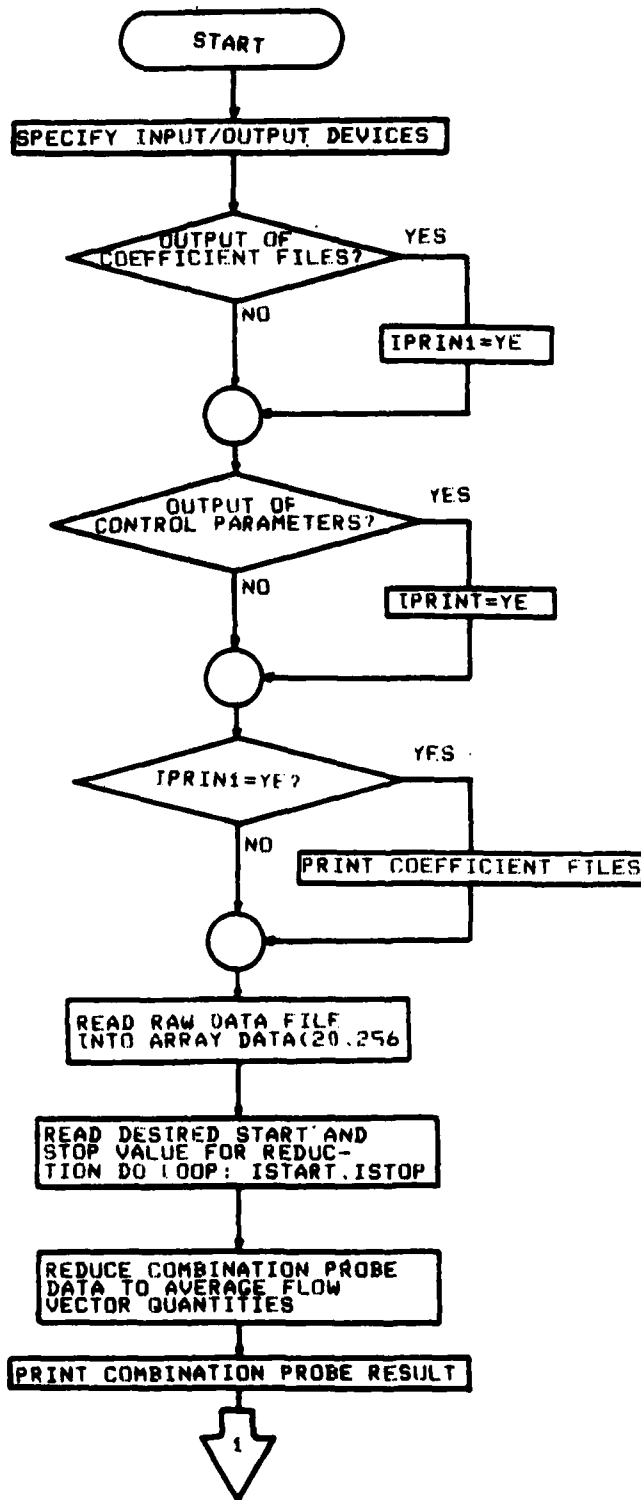

Figure J-1. Flow Chart of Data Reduction Program &ABRED.

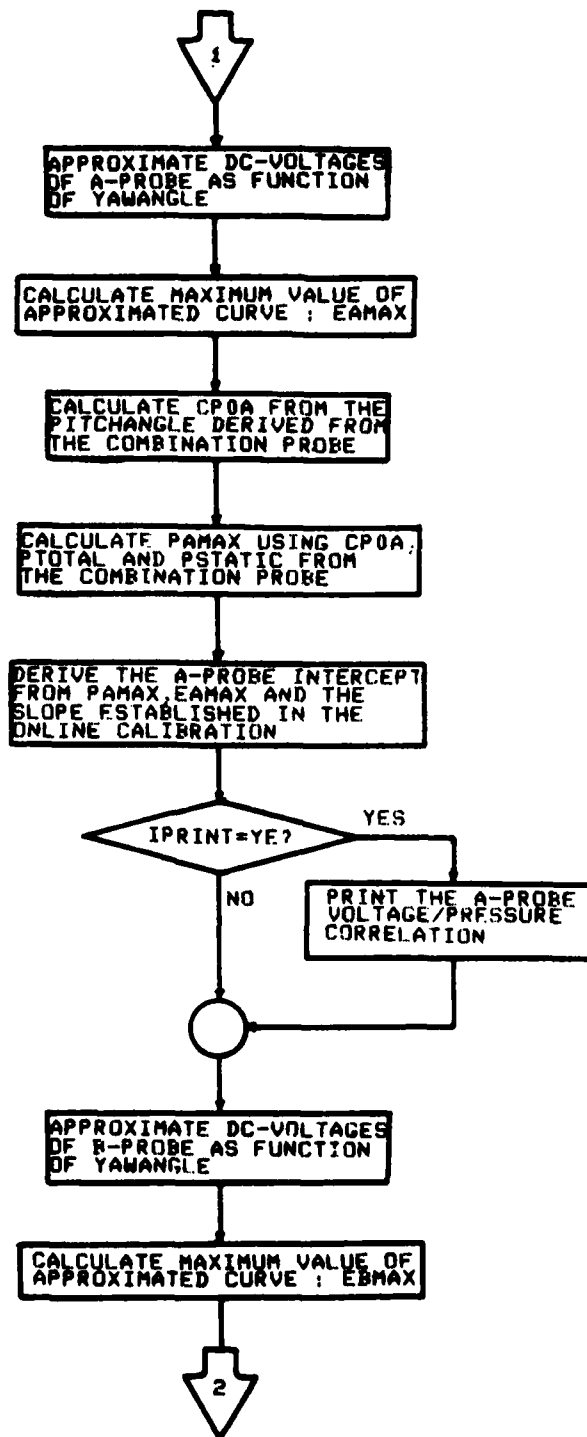

Figure J-1. Flow Chart of Data Reduction Program &ABRED.

con't

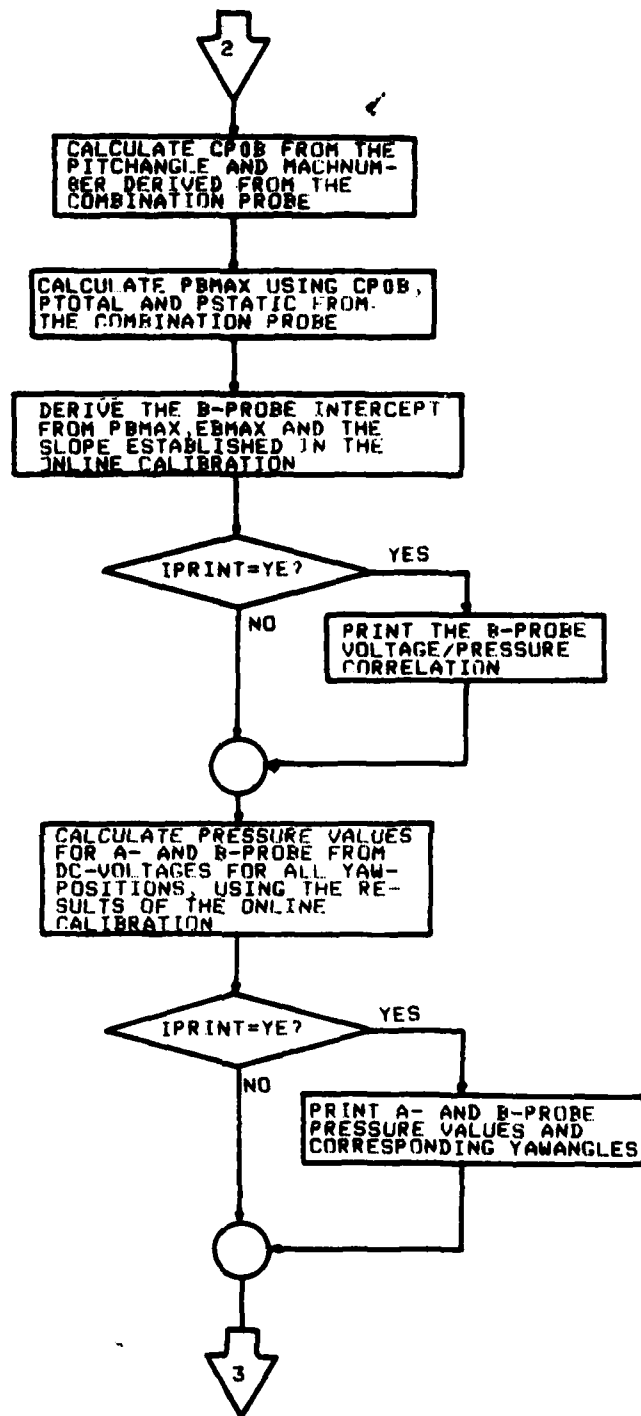

Figure J-1. Flow Chart of Data Reduction Program &ABRED.

con't

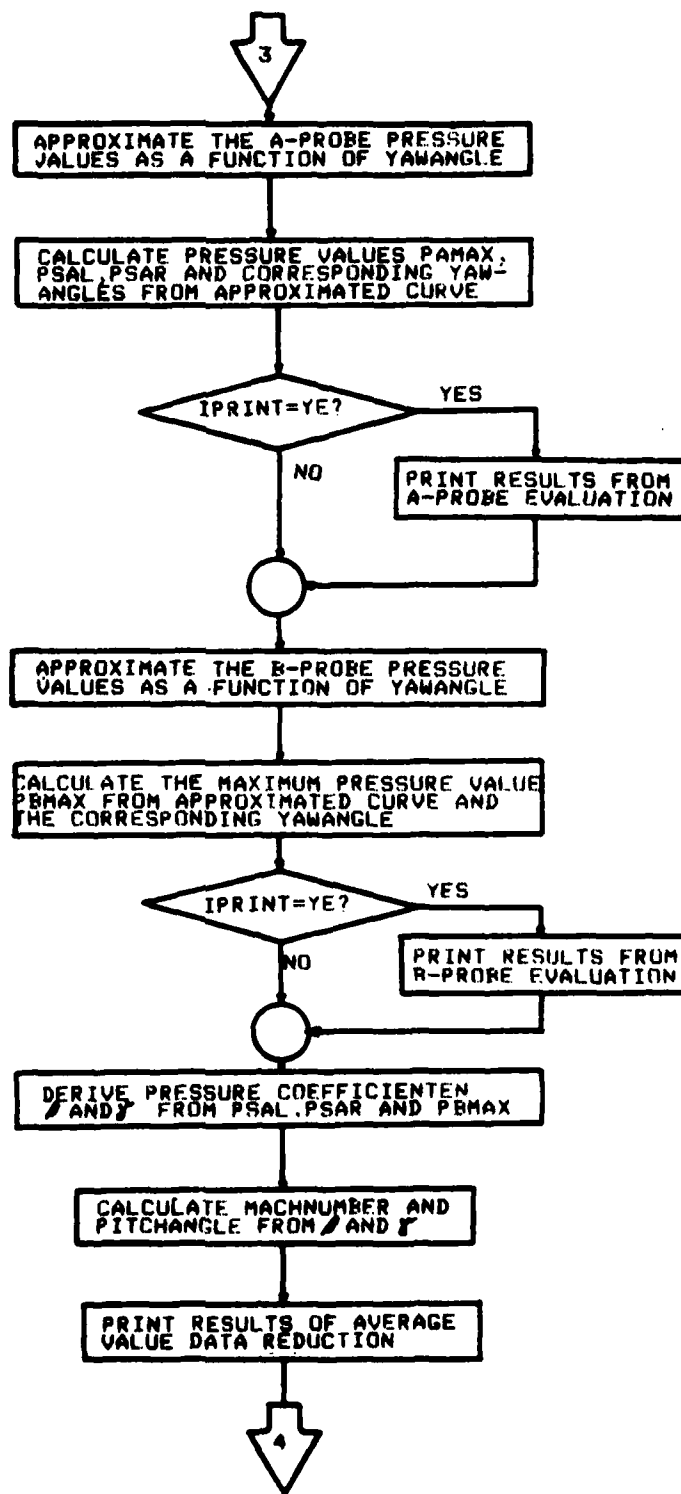

Figure J-1. Flow Chart of Data Reduction Program &ABRED.

con't

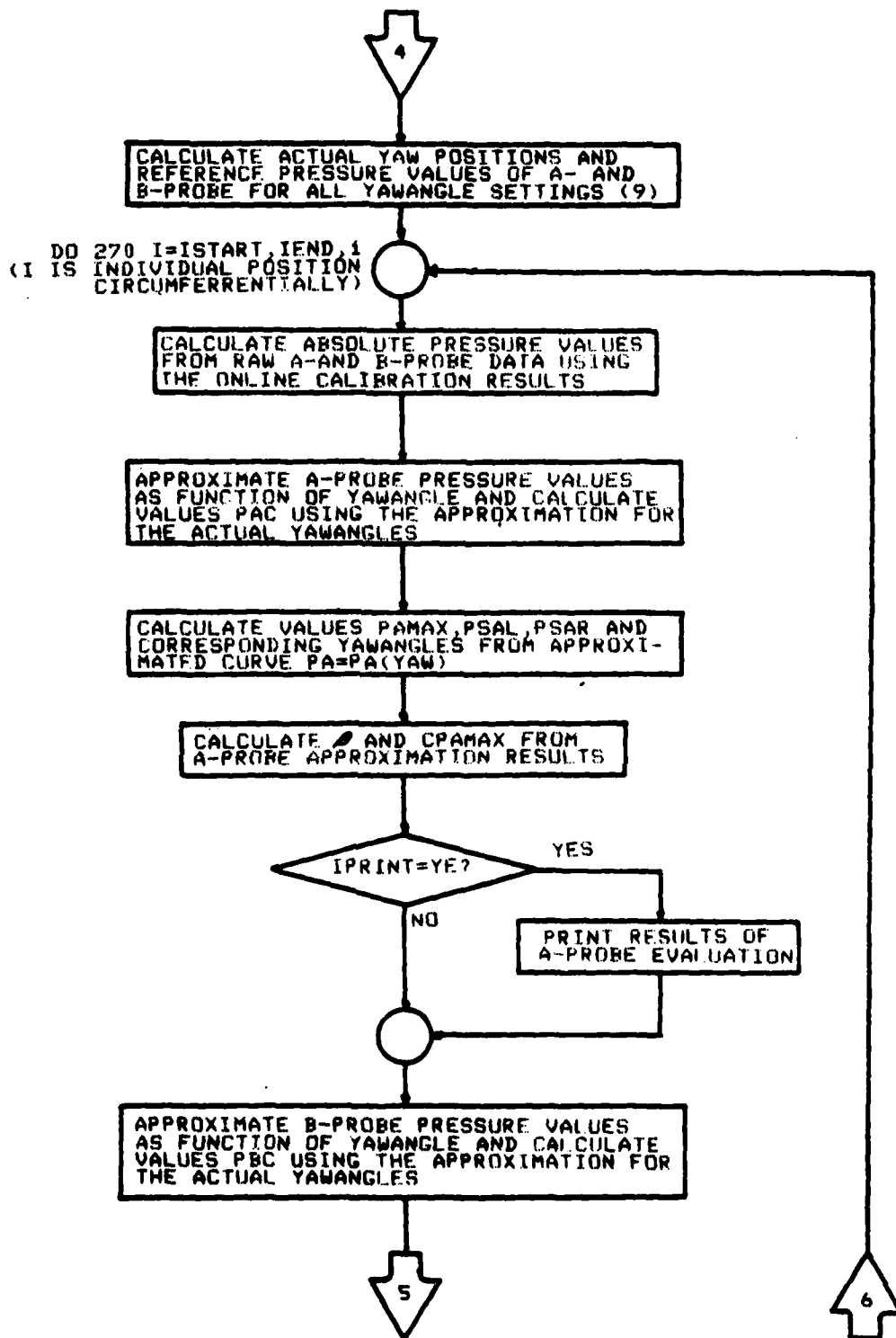

Figure J-1. Flow Chart of Data Reduction Program &ABRED.

con't

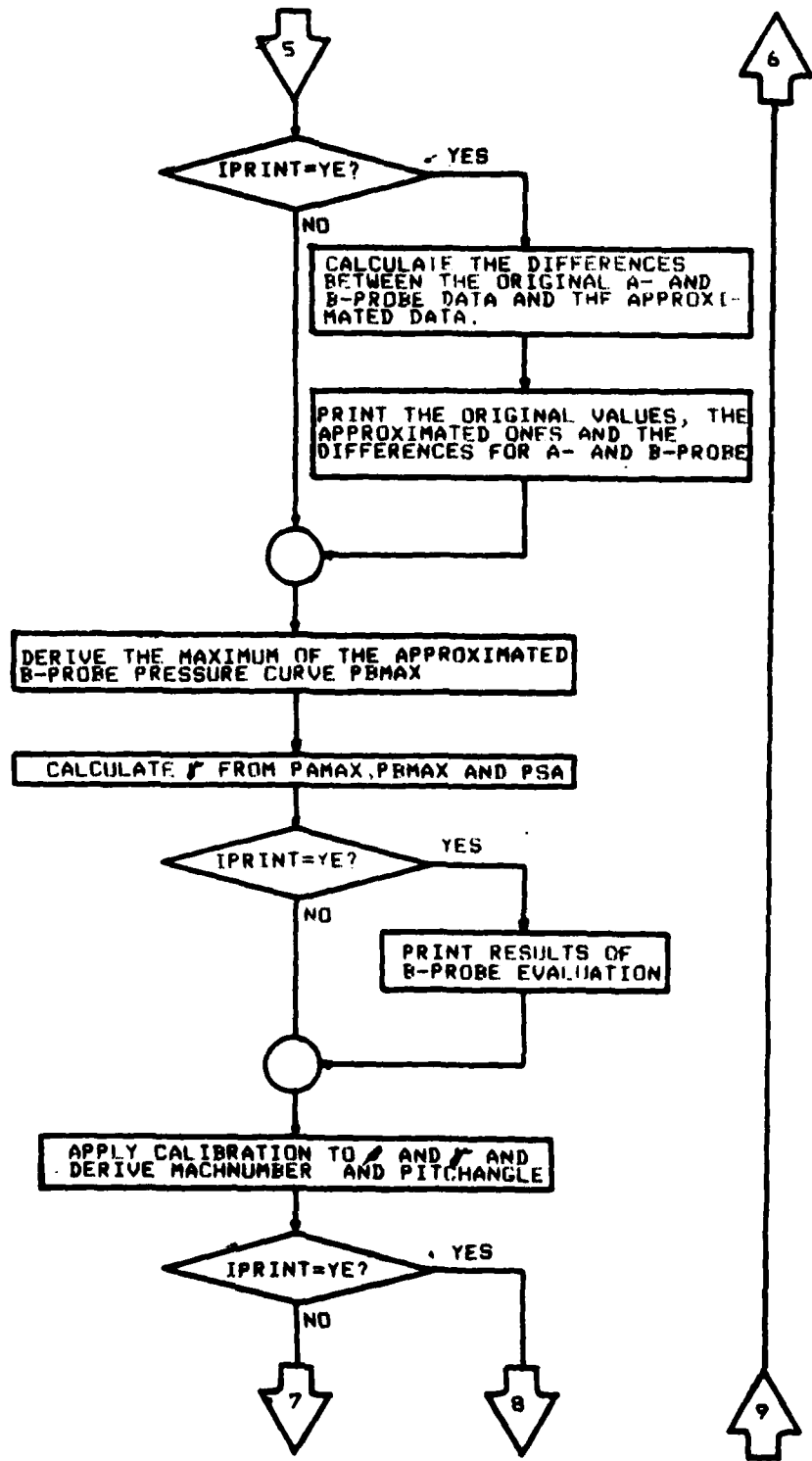

Figure J-1. Flow Chart of Data Reduction Program &ABRED.

con't

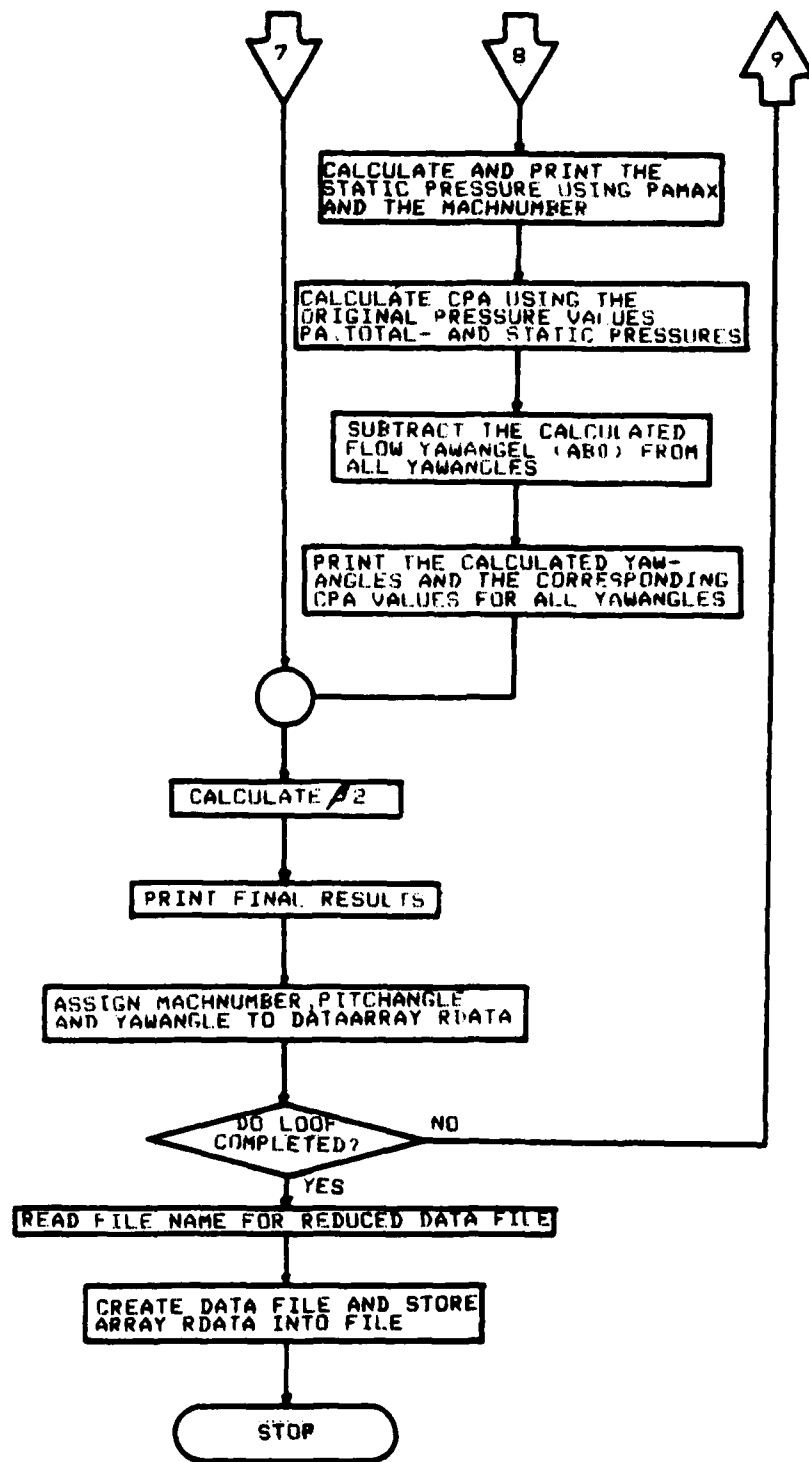

Figure J-1. Flow Chart of Data Reduction Program &ABRED.

con't

6ABRED T-00004 IS ON CR0027 USING 00142 BLKS R=0000

```
0001 FTN4,L
0002 PROGRAM 6ABRED (3,99)
0003 .....
0004 THIS IS PROGRAM 6ABRED(uction) FOR THE A-B PROBE SYSTEM.
0005 .....
0006 IN THIS VERY VERSION THE PROGRAM IS SET UP FOR THE NEW A-B-
0007 PROBES (0.063" O.D., SCREEN WITH HOLES ON A CIRCLE ).
0008 .....
0009 IF ANY OTHER PROBES (KULITE AS WELL AS COMBINATION PROBE)
0010 SMALL BE USED, THE CORRECT FILE NAMES FOR THE COEFFICIENT
0011 FILES HAVE TO BE PUT IN :
0012 .....
0013 FILE # CONTAINS APPROX. COEFFICIENTS: DATA ARRAY NAME
0014 .....
0015 1 KULITE PROBES MACHNUMBER COEXX
0016 2 KULITE PROBES PITCHANGLE COEKP
0017 3 KULITE PROBES CP00 COECP
0018 4 COMBINATION PROBE MACHNUMBER CDEOX
0019 5 COMBINATION PROBE PITCHANGLE COEOP
0020 .....
0021 .....
0022 COMMON / 01A2 / X1(256) Y1(256) COEF(7)
0023 REAL DATA(20,256), X1(256) Y1(256) COEF(7)
0024 REAL COEEX(7,7), COEOP(7,7), COEXX(7,7), COEKP(7,7), COECPB(7,7)
0025 REAL PAA(9), PAR(9), YAWA(9), YAMB(9)
0026 REAL PA(9), PB(9), PAC(9), PREFP(9)
0027 REAL RDATA(3,256)
0028 DIMENSION CP0A(6)
0029 INTEGER IDCX(144), IFILE(3), ISIZE(2)
0030 INTEGER NOLF, NOLP(12), ICLR(3)
0031 DATA CP0A(1) / 0.025921 /
0032 DATA CP0A(2) / 0.0356475 /
0033 DATA CP0A(3) / -0.2724224 /
0034 DATA CP0A(4) / 0.9320285 /
0035 DATA CP0A(5) / -2.333180 /
0036 DATA CP0A(6) / 0.0000000 /
0037 DATA IDCBS / 144 /
0038 DATA ITYPE / 015524B,015515B,006537B /
0039 DATA NOLF / 006537B /
0040 .....
0041 300 FORMAT (" OUTPUT INPUT DATA TO ANY OTHER DEVICE? ENTER NO
0042 & OR LUB 1/" "A2")
0043 305 FORMAT (I2)
0044 310 FORMAT (" DO YOU WANT AN OUTPUT OF THE CALIBRATION COEFFICIENTS?"
0045 &/" ENTER YES IF SO OR ANYTHING ELSE IF NOT!"/" "A2")
0046 315 FORMAT (" DO YOU WANT AN OUTPUT OF THE CONTROL PARAMETERS?"/" KE
0047 &Y YES IF SO OR ANYTHING ELSE IF NOT!"/" "A2")
0048 320 FORMAT (" THE DATA READ FROM FILE "3A2" ARE"/)
0049 325 FORMAT (" I / 1" / 1)
0050 330 FORMAT (" IS 1/(X,F11.6))
0051 335 FORMAT (" ENTER RAW DATA FILE"/)
0052 &" DON'T FORGET SECURITY CODE & CARTRIDGE REFERENCE NUMBER!"/"
0053 &" "A2")
0054 340 FORMAT ((3A2),1X,I2,1X,I2)
0055 345 FORMAT (" ENTER THE NUMBER OF THE START AND END POSITION :"/)
0056 &" "A2")
0057 350 FORMAT (I3,1X,I3)
0058 355 FORMAT (" *****")
0059 &" RAW DATA FILE "3A2" : "I3")
0060 &" *****")
0061 360 FORMAT (" FLOW AVERAGED VALUES AS ESTABLISHED WITH THE COMBINATION
0062 & PROBE"/) Pstatic(INCH H20) Pstatic(INCH H20) "SX"Xvel"6X"mach"2X"
0063 &PHI(deg) 2X"YAW(deg)"/2(5X,F13.6) 2(2X,F8.5) 2(3X,F7.2)/)
0064 365 FORMAT (" EQUATION FOR A-PROBE PRESSURE :"/ PA = "F12.6" + " F12.
0065 &" & VOLTAGE (POW)80.01 + PREF (INCH H20)"/)
0066 370 FORMAT (" CP0A = "F10.5" CP0B = "F10.7)
0067 375 FORMAT (" EQUATION FOR B-PROBE PRESSURE :"/ PB = "F12.6" + " F12.
0068 &" & VOLTAGE (POW)80.01 + PREF (INCH H20)"/)
0069 380 FORMAT (" & PAA(9) PAB(9) YAWA(9) YAMB(9)"/)
0070 385 FORMAT (I2,4(1X,F7.5))
0071 390 FORMAT (" A-PROBE APPROXIMATION RESULTS : YAW = "3(5X,F9.2)/16X" PR
0072 &SSURE (INCH H20) = "3(3X,F11.6)/29X" CPAMAX = "F8.4"/)
0073 395 FORMAT (" B-PROBE APPROXIMATION RESULTS : YAWB = "F5.1" PRESSURE
0074 &(INCH H20) = "F8.3"/)
0075 400 FORMAT (" AVERAGE VALUE RESULTS FROM THE A-B SYSTEM:"/"5X"ETA"4X"Q
0076 &AMMA"5X"Xvel"4X"Pitch"6X"YAW"7X"XU"6X"XAX"4X"BETA"2(3X,F
0077 &"-2).2(F9.5) 2X,F-1.2)
0078
```

Figure J-2. Listing of Data reduction Program 6ABRED.
(Continued on next page.)

```

7079 405 FORMAT(////////// " POS0"6X"Beta"5X"Gamma"6X"Xvel"5X"Pitch"7X"Yaw"5
7080 6X"BETA2")
7081 410 FORMAT(" 0 YAMA(I) PA(I) PAC(I) DPA YAMB(I) P
7082 8BC(I) PBC(I) DPB")
7083 415 FORMAT(12,8(3X,F7.5))
7084 420 FORMAT(7,8(F10.5),3(32,F7.2))
7085 425 FORMAT(" 0 ACTUAL YAW ANGLE CPA")
7086 430 FORMAT(14,12X,F6.2,3X,F6.3)
7087 435 FORMAT(15,3(F10.5),3(32,F7.2))
7088 440 FORMAT(" ENTER THE NAME FOR THE FILE CONTAINING REDUCED DATA!" /
7089 " DON'T FORGET SECURITY CODE & CARTRIDGE REFERENCE NUMBER!" /
7090 " 1 "A2")
7091 445 FORMAT(/// " REDUCED DATA STORED IN FILE : "3A2"."12)
7092 1111 FORMAT(" STATEMENT 0 "14" ERROR 0 "12.2"DETECTED ")
7093 1149 FORMAT(13A2))
7094 LI = LOGLU(ISSSN)
7095 005 WRITE (LI, 308) NOLF
7096 READ (LI,1149) IDUM
7097 WRITE (LI,1149) (ICLR,I11=1,2)
7098 IF ( IDUM .EQ. 2HNO ) GO TO 010
7099 CALL CODE
7100 READ (IDUM,305) LO
7101 IF ( LO .EQ. 1 ) GO TO 015
7102 IF ( LO .EQ. 6 ) GO TO 015
7103 IF ( LO .EQ. 18 ) GO TO 015
7104 GO TO 005
7105 010 LO = 0
7106 015 IF ( LO .EQ. LI ) LO = 0
7107 WRITE (LI, 310) NOLF
7108 READ (LI,1149) IPRIN1
7109 WRITE (LI,1149) (ICLR,I11=1,3)
7110 WRITE (LI, 315) NOLF
7111 READ (LI,1149) IPRINT
7112 WRITE (LI,1149) (ICLR,I11 = 1,3)
7113 .....
7114 .. READ COEFFICIENTFILE FOR THE KULITE MACHNUMBER APPROXIMATION
7115 .. FROM DISC INTO ARRAY COEKX(7,7).
7116 .....
7117 .....
7118 IFILE(1) = 2HW
7119 IFILE(2) = 2HST
7120 IFILE(3) = 2HXV
7121 ISECU = 00
7122 ICR = 26
7123 CALL OPEN (IDCB,IERR,IFILE,IOPTN,ISECU,ICR,IDCBS)
7124 JJ = 1
7125 IF ( IERR .LT. 0 ) WRITE (LI,1111) JJ,IERR
7126 CALL READF (IDCB,IERR,COEKX,98,LEN,1)
7127 JJ = 3
7128 IF ( IERR .LT. 0 ) WRITE (LI,1111) JJ,IERR
7129 CALL CLOSE (IDCB,IERR,0)
7130 JJ = 3
7131 IF ( IERR .LT. 0 ) WRITE (LI,1111) JJ,IERR
7132 IF ( IPRIN1 .NE. 2HYE ) GOTO 025
7133 .....
7134 .....
7135 OUTPUT INPUT DATA.
7136 .....
7137 .....
7138 WRITE (LI, 320) IFILE
7139 IF ( LO .NE. 0 ) WRITE (LO, 320) IFILE
7140 WRITE (LI, 325) (I1,I1=1,7)
7141 IF ( LO .NE. 0 ) WRITE (LO, 325) (I1,I1=1,7)
7142 DO 020 I1=1,7,1
7143 IF ( LO .NE. 0 ) WRITE (LO, 330) I1,(COEKX(I1,J1),J1=1,7,1)
7144 020 WRITE (LI, 330) I1,(COEKX(I1,J1),J1=1,7,1)
7145 .....
7146 .....
7147 .. READ COEFFICIENTFILE FOR THE KULITE PITCHANGLE APPROXIMATION
7148 .. FROM DISC INTO ARRAY COEKP(7,7).
7149 .....
7150 .....
7151 025 IFILE(1) = 2HW
7152 IFILE(2) = 2HST
7153 IFILE(3) = 2HFI
7154 CALL OPEN (IDCB,IERR,IFILE,IOPTN,ISECU,ICR,IDCBS)
7155 JJ = 4
7156 IF ( IERR .LT. 0 ) WRITE (LI,1111) JJ,IERR
7157 CALL READF (IDCB,IERR,COEKP,98,LEN,1)
7158 .....

```

Figure J-2. Listing on Data Reduction Program SABRED.
(Continued on next page.)

```

0159      JJ = 5
0160      IF ( IERR .LT. 0 ) WRITE (LI,1111) JJ,IERR
0161      CALL CLOSE (IDCB,IERR,0)
0162      IF ( IERR .LT. 0 ) WRITE (LI,1111) JJ,IERR
0163      IF ( IPRINI .NE. 2NVE) GOTO 035
0164      .....
0165      OUTPUT INPUT DATA.
0166      .....
0167      WRITE (LI, 320) IFILE
0168      IF ( LO .NE. 0 ) WRITE (LO, 320) IFILE
0169      WRITE (LI, 325) (I1,I1=1,7)
0170      IF ( LO .NE. 0 ) WRITE (LO, 325) (I1,I1=1,7)
0171      DO 030 I1=1,7,1
0172      IF ( LO .NE. 0 ) WRITE (LO, 330) I1,(COERP(I1,J1),J1=1,7,1)
0173      DO 030 I1=1,7,1
0174      IF ( LO .NE. 0 ) WRITE (LO, 330) I1,(COERP(I1,J1),J1=1,7,1)
0175      .....
0176      030 READ COEFFICIENTFILE FOR THE KULITE CP08 APPROXIMATION
0177      FROM DISC INTO ARRAY COECP(7,7).
0178      .....
0179      035 IFILE(1) = 2MVI
0180      IFILE(2) = 2MST
0181      IFILE(3) = 2MCP
0182      CALL OPEN (IDCB,IERR,IFILE,IOPTN,ISECU,ICR,IDCBS)
0183      JJ = 7
0184      IF ( IERR .LT. 0 ) WRITE (LI,1111) JJ,IERR
0185      CALL READF (IDCB,IERR,COECP,90,LEN,1)
0186      JJ = 8
0187      IF ( IERR .LT. 0 ) WRITE (LI,1111) JJ,IERR
0188      CALL CLOSE (IDCB,IERR,0)
0189      JJ = 9
0190      IF ( IERR .LT. 0 ) WRITE (LI,1111) JJ,IERR
0191      IF ( IPRINI .NE. 2NVE) GOTO 045
0192      .....
0193      OUTPUT INPUT DATA.
0194      .....
0195      WRITE (LI, 320) IFILE
0196      IF ( LO .NE. 0 ) WRITE (LO, 320) IFILE
0197      WRITE (LI, 325) (I1,I1=1,7)
0198      IF ( LO .NE. 0 ) WRITE (LO, 325) (I1,I1=1,7)
0199      DO 040 I1=1,7,1
0200      IF ( LO .NE. 0 ) WRITE (LO, 330) I1,(COECP(I1,J1),J1=1,7,1)
0201      DO 040 I1=1,7,1
0202      IF ( LO .NE. 0 ) WRITE (LO, 330) I1,(COECP(I1,J1),J1=1,7,1)
0203      .....
0204      040 READ COEFFICIENTFILE FOR THE COMBINATIONPROBE MACHNUMBER
0205      APPROXIMATION INTO ARRAY COEOX(7,7).
0206      .....
0207      045 ICR = 28
0208      IFILE(1) = 2MCD
0209      IFILE(2) = 2MEF
0210      IFILE(3) = 2M2X
0211      CALL OPEN (IDCB,IERR,IFILE,IOPTN,ISECU,ICR,IDCBS)
0212      JJ = 10
0213      IF ( IERR .LT. 0 ) WRITE (LI,1111) JJ,IERR
0214      CALL READF (IDCB,IERR,COEOX,90,LEN,1)
0215      JJ = 11
0216      IF ( IERR .LT. 0 ) WRITE (LI,1111) JJ,IERR
0217      CALL CLOSE (IDCB,IERR,0)
0218      JJ = 12
0219      IF ( IERR .LT. 0 ) WRITE (LI,1111) JJ,IERR
0220      IF ( IPRINI .NE. 2NVE) GOTO 055
0221      .....
0222      OUTPUT INPUT DATA.
0223      .....
0224      WRITE (LI, 320) IFILE
0225      IF ( LO .NE. 0 ) WRITE (LO, 320) IFILE
0226      WRITE (LI, 325) (I1,I1=1,7)
0227      IF ( LO .NE. 0 ) WRITE (LO, 325) (I1,I1=1,7)
0228      DO 050 I1=1,7,1
0229      IF ( LO .NE. 0 ) WRITE (LO, 330) I1,(COEOX(I1,J1),J1=1,7,1)
0230      IF ( LO .NE. 0 ) WRITE (LO, 330) I1,(COEOX(I1,J1),J1=1,7,1)

```

Figure J-2. Listing of Data Reduction Program &ABRED.
(Continued on next page.)

```

239 050 WRITE (LI, 330) I1,(COEOP(I1,J1),J1=1,7,1)
240 .....
241 READ COEFFICIENTFILE FOR THE COMBINATIONPROBE PITCHANGLE
242 APPROXIMATION INTO ARRAY COEOP(7,7).
243 .....
244 055 IFILE(1) = 2MCO
245 IFILE(2) = 2MEF
246 IFILE(3) = 2M2P
247 CALL OPEN (IDCB,IERR,IFILE,IOPTN,ISECU,ICR,IDCBS)
248 JJ = 13
249 IF ( IERR .LT. 0 ) WRITE (LI,1111) JJ,IERR
250 CALL READF (IDCB,IERR,COEOP,98,LEN,1)
251 IF ( IERR .LT. 0 ) WRITE (LI,1111) JJ,IERR
252 CALL CLOSE (IDCB,IERR,0)
253 JJ = 15
254 IF ( IERR .LT. 0 ) WRITE (LI,1111) JJ,IERR
255 IF (IPRINT .NE. 2MVE) GOTO 065
256 .....
257 OUTPUT INPUT DATA.
258 .....
259 WRITE (LI, 320) IFILE
260 IF ( LO .NE. 0 ) WRITE (LO, 320) IFILE
261 WRITE (LI, 325) (I1,I1=1,7)
262 IF ( LO .NE. 0 ) WRITE (LO, 325) (I1,I1=1,7)
263 DO 060 I1=1,7,1
264 IF ( LO .NE. 0 ) WRITE (LO, 330) I1,(COEOP(I1,J1),J1=1,7,1)
265 060 WRITE (LI, 330) I1,(COEOP(I1,J1),J1=1,7,1)
266 .....
267 065 WRITE (LI, 335) NOLF
268 READ (LI, 340) IFILE,ISECU,ICR
269 WRITE (LI,149) (ICLR,I1 =1,3)
270 I1 = 10240
271 ISIZE(1) = 80
272 ISIZE(2) = 128
273 CALL OPEN (IDCB,IERR,IFILE,IOPTN,ISECU,ICR,IDCBS)
274 JJ = 13
275 IF ( IERR .LT. 0 ) WRITE (LI,1111) JJ,IERR
276 CALL READF (IDCB,IERR,DATA,IL,LEN,1)
277 IF ( IERR .LT. 0 ) WRITE (LI,1111) JJ,IERR
278 CALL CLOSE (IDCB,IERR,0)
279 JJ = 15
280 IF ( IERR .LT. 0 ) WRITE (LI,1111) JJ,IERR
281 WRITE (LI,345) NOLF
282 READ (LI,350) ISTART,IEND
283 WRITE (LI,355) IFILE,ICR
284 IF ( LO .NE. 0 ) WRITE (LO,355) IFILE,ICR
285 .....
286 COMBINATION PROBE DATA REDUCTION.
287 .....
288 P1 = 0.0
289 P23 = 0.0
290 P4 = 0.0
291 PREF = 0.0
292 RPM = 0.0
293 RADIS = 0.0
294 YAW = 0.0
295 TT2 = 0.0
296 DO 070 I = 1,7,1
297 J = I-1 * 70
298 PRARO = DATA(20,J+7)*1.3585
299 P1 = P1 + (DATA(20,J+3) - DATA(20,J+1) + PRARO)*100*1000
300 P23 = P23 + (DATA(20,J+4) - DATA(20,J+1) + PRARO)*100*1000
301 P4 = P4 + (DATA(20,J+5) - DATA(20,J+1) + PRARO)*100*1000
302 PREF = PREF + DATA(20,J+14) * 100 * 1000
303 RPM = RPM + DATA(20,J+8) * 10
304 RADIS = RADIS + (DATA(20,J+9)+DATA(20,J+10)+DATA(20,J+12))/3*1000
305 YAW = YAW + DATA(20,J+9) * 10000
306 TT2 = TT2 + (DATA(20,J+15) + DATA(20,J+16)) * 1000
307 070 P1 = P1 / 0
308 P23 = P23 / 0
309 P4 = P4 / 0
310
311
312
313
314
315
316
317
318

```

Figure J-2. Listing of Data Reduction Program &ABRED.
(Continued on next page.)

```

319 PREF = PRF / 9
320 RPH = RPR / 9
321 RADIS = RADIS / 9
322 RADIS = 5.51 - RADIS
323 YAW = YAW / 9
324 TT2 = TT2 / 9
325 TT2 = J1.9557 + 30.6827 * TT2 - 0.3679 * TT2 * TT2
326 TT2 = ((TT2 - 32) * 5 / 9) + 273.15
327 UT2 = SQRT ( 2888 * TT2 )
328 U = (RPM / 60) * RADIS * 2 * 3.14159 * 0.0254
329 XU = U / UT2
330 BETA = ( P1 - P23 ) / P1
331 GAMMA = ( P1 - P4 ) / ( P1 - P23 )
332 DELTA = GAMMA * BETA
333
334 XVEL = 0.0
335 PHI = 0.0
336 DO 075 I1 = 1,7,1
337 DO 075 I2 = 1,7,1
338 XVEL = XVEL + (COEX(I1,I2)*DELTA**I2-1)*GAMMA**I1-1
339 PHI = PHI + (CEDP(I1,I2)*DELTA**I2-1)*GAMMA**I1-1
340 XM = SQRT ((2/(1.402-1))*(XVEL*XVEL)/(1-(XVEL*XVEL)))
341 PSTAT = P1
342 PSTAT = PSTAT * (1-XVEL*XVEL)**(1.402/402)
343 WRITE (LI,360) PSTAT,PSTAT,XVEL,PHI,YAW
344 IF ( LO.NE.0 ) WRITE (LO,360) PSTAT,PSTAT,XVEL,PHI,YAW
345 .....
346 PERFORM ONLINE CALIBRATION. A-PROBE FIRST.
347 .....
348 .....
349 .....
350 .....
351 .....
352 .....
353 .....
354 .....
355 .....
356 .....
357 .....
358 DO 080 I = 1,5,1
359 J = (I-1) * 20
360 X1(I) = DATA(20,I+1) * 10000 * 3.14159 / 180
361 Y(I) = DATA(20,I+17)
362 CALL MAT2 (9,5,COEF,-4)
363 .....
364 INITIAL ESTIMATE FOR THE APPROXIMATION IS :YAW = 22 (deg)
365 .....
366 .....
367 X0 = 0.4
368 DEAMAX = FND (4,COEF,X0)
369 IF (ABS(DEAMAX) .LT. 0.0001) GOTO 090
370 X0 = X0 - DEAMAX / (2*COEF(3)+6*COEF(4)*X0+12*COEF(5)*X0*X0)
371 GOTO 085
372 DEAMAX = FND(4,COEF,X0)
373 SLOPEA = (DATA(1,180) + DATA(1,180))/(-2.0)*100*1000
374 PHI = PHI + 3.14159 / 180.
375 .....
376 CALCULATE CP0A(EQ3) FROM COMBINATION PROBE RESULTS (PITCH)
377 .....
378 EQ3 = FND (4,CP0A,PHI)
379 PAMAX = EQ3 * (PTOTAL-PSTAT) + PSTAT
380 SECTA = PAMAX - PREF - SLOPEA * EAMAX + EAMAX
381 PUA = SECTA + SLOPEA * EAMAX + PREF
382 IF ( IPRINT.NE.2HYE ) GOTO 095
383 WRITE (LI,365) SECTA,SLOPEA
384 IF ( LO.NE.0 ) WRITE (LO,365) SECTA,SLOPEA
385 095 CONTINUE
386 .....
387 .....
388 .....
389 .....
390 .....
391 .....
392 .....
393 .....
394 DO 100 I = 1,8,1
395 J = (I-1) * 20
396 X1(I) = DATA(20,I+13) * 10000 * 3.14159 / 180
397 Y(I) = DATA(20,I+18)
398 CALL MAT2 (8,5,COEF,-4)
399 .....
400 .....

```

Figure J-2. Listing of Data Reduction Program &ABRED.
(Continued on next page.)

```

0399          INITIAL ESTIMATE FOR THE APPROXIMATION IS : YAW = 0 (deg)
0400
0401          .....
0402          X0 = 0.0
0403          DEBMA = FND (4,COEF,X0)
105          IF (ABS(DEBMA) .LT. 0.00001 ) GOTO 110
0404          X0 = X0 - DEBMA / (2*COEF(3)+6*COEF(4)*X0+12*COEF(5)*X0*X0)
0405          GOTO 105
0406          EQ5 = FNP (4,COEF,X0)
110          ERMAX = PSTAT - PREF
0407          PSTAT = 0.0
0408          EQ5 = 0.0
0409          .....
0410          CALCULATE CP0B FROM COMBINATION PROBE RESULTS.
0411          .....
0412          DO 115 I1 = 1,5,1
0413          DO 115 J1 = 1,5,1
0414          EQ5 = EQ5 + (COECPB(I1,J1)*XVEL*(J1-1))*PHIS*(I1-1)
115          WRITE (LI,370) EQ5,EQ5
0416          IF (LO .NE. 0) WRITE (LO,370) EQ5,EQ5
0417          POB = EQ5 * (PTOTAL-PSTAT) + PSTAT
0418          PKB = POB + PREF
0419          SLOPB = (DATA(1,170) + DATA(1,190)) / (-2.0) * 100*1000
0420          SECTB = PKB - PREF - SLOPB * ERMAX
0421          IF ( IPRINT .NE. 2HYES ) GOTO 120
0422          WRITE (LI,375) SECTB,SLOPB
0423          IF (LO .NE. 0) WRITE (LO,375) SECTB,SLOPB
0424          120 CONTINUE
0425          .....
0426          START DATA REDUCTION.
0427          FIRST CALCULATE THE AVERAGE FLOW PARAMETERS USING THE
0428          OVERALL VALUES FROM THE A AND B PROBE AND THE JUST
0429          ESTABLISHED CALIBRATION.
0430          .....
0431          DO 125 I = 1,9,1
0432          PAA(I) = (I-1) * 20
0433          PAB(I) = DATA(20,J+17)
0434          PAA(I) = SECTA + SLOPEA * PAA(I) + DATA(20,J+14)*100*1000
0435          PAB(I) = SECTB + SLOPER * PAB(I) + DATA(20,J+14)*100*1000
0436          YAWA(I) = DATA(20,J+11) * 10000
0437          YAWB(I) = DATA(20,J+13) * 10000
0438          IF ( IPRINT .NE. 2HYES ) GOTO 135
0439          WRITE (LI,380)
0440          IF (LO .NE. 0) WRITE (LO,380)
0441          DO 130 I = 1,9,1
0442          WRITE (LI,385) I,PAA(I),PAB(I),YAWA(I),YAWB(I)
130          IF (LO .NE. 0) WRITE (LO,385) I,PAA(I),PAB(I),YAWA(I),YAWB(I)
0443          135 CONTINUE
0444          .....
0445          APPROXIMATE A-PROBE PRESSURES.
0446          .....
0447          DO 140 I = 1,9,1
0448          X1(I) = YAWA(I)
140          Y(I) = PAA(I)
0449          CALL MAT2 (9,5,COEF,-4)
0450          .....
0451          FIND MAX. OUTPUT OF A PROBE.
0452          .....
0453          DX = 126.0
0454          X0 = -40.0
145          DP = (FNP(4,COEF,X0) - FNP(4,COEF,(X0+DX)))
0456          IF (ABS(DP) .LT. 0.0001 ) GOTO 150
0457          DPX = -2.0*COEF(3)*DX-6.0*COEF(4)*X0*DX-3.0*COEF(4)*DX*DX-
0458          12.0*COEF(5)*X0*X0*DX-12*COEF(5)*X0*DX*DX-4.0*COEF(5)*DX**3
0459          X0 = X0 - DP / DPX
0460          GOTO 145
0461          150 ASL = X0
0462          ASR = X0 + DX
0463          AAO = X0 + DX / 2.0
0464          PAMAX = FNP(4,COEF,AAO)
0465
0466
0467
0468
0469
0470
0471
0472
0473
0474
0475
0476
0477
0478

```

Figure J-2. Listing of Data Reduction Program &ABRED.
(Continued on next page.)

```

1479 PSAL = FND(4,COEF,ASL)
1480 PSAR = FND(4,COEF,ASR)
1481 PSA = (PSAL + PSAR) / 2.0
1482
1483 BETA = (PAMAX - PSA) / PAMAX
1484 CPAMAX = (PAMAX - PSA) / (PTOTAL - PSA)
1485 IF ( IPRINT, NE, ZHYE ) GOTO 155
1486 WRITE (LI,398) AB, AA, ASR, PSAL, PAMAX, PSAR, CPAMAX
1487 IF ( LO, NE, 0 ) WRITE (LO,398) ASL, AA, ASR, PSAL, PAMAX, PSAR, CPAMAX
1488
155 CONTINUE
.....
      APPROXIMATE B PROBE PRESSURES.
.....
DO 160 I = 1,9,1
1491 X1(I) = YAMB(I)
1492 Y(I) = PAB(I)
1493 CALL MAT2 (9,5,COEF,-4)
.....
      FIND MAXIMUM OUTPUT OF B-PROBE.
.....
X0 = 0.00
165 DPX = FND(4,COEF,X0)
IF ( ABS(DPX) .LT. 0.00001 ) GOTO 170
X0 = X0 - DPX / (2*COEF(3) + 6*COEF(4)*X0 + 12*COEF(5)*X0*X0)
GOTO 165
170 AB0 = X0
PBMAX = FND(4,COEF,AB0)
IF ( IPRINT, NE, ZHYE ) GOTO 175
WRITE (LI,395) AB0, PBMAX
IF ( LO, NE, 0 ) WRITE (LO,395) AB0, PBMAX
175 CONTINUE
CPBMAX = ( PBMAX - PSA ) / (PTOTAL - PSA)
GAMMA = (CPAMAX - CPBMAX) / CPAMAX
XVEL = 0.0
PHI = 0.0
DO 180 I1 = 1,2,1
DO 180 I2 = 1,2,1
180 XVEL = XVEL + (CDEKX(I1,I2) * GAMMA**2(I2-1) * BETA**2(I1-1)
PHI = PHI + (CDEKP(I1,I2) * GAMMA**2(I2-1) * BETA**2(I1-1)
PHI = PHI + 180 / 3.14159
XAX = XVEL * COS(PHI*3.14159/180) * COS(AR0*3.14159/180)
BETA2 = ATAN((XU-XVEL * COS(PHI*3.14159/180) * SIN(AR0*3.14159/180)
* / XAX) * 180 / 3.14159)
WRITE (LI,400) BETA,GAMMA,XVEL,PHI,AB0,XU,XAX,BETA2
IF(LO, NE, 0) WRITE (LO,400) BETA,GAMMA,XVEL,PHI,AB0,XU,XAX,BETA2
.....
      START OF DATA REDUCTION FOR INDIVIDUAL POSITIONS.
.....
.....
      Calculation of values which are valid for all positions.
.....
WRITE (LI,405)
IF ( LO, NE, 0 ) WRITE (LO,405)
DO 185 I = 1,9,1
185 J = (I-1) * 20
YAMB(I) = DATA(20,J+11) * 10000
YAMB(I) = DATA(20,J+13) * 10000
PREFP(I) = DATA(20,J+14) * 100*1000
.....
      START OF DO LOOP
.....
DO 270 I = ISTART, IEND, 1
DO 190 J = 1,9,1
190 J1 = J * 2, 1
J2 = J * 2 + 1
PA(J) = DATA(J1,I) * 0.01
PR(J) = DATA(J2,I) * 0.01
PA(J) = SECTA + SLOPEA * PA(J) + PREFP(J)

```

Figure J-2. Listing of Data Reduction Program &ABRED.
(Continued on next page.)

```

5559 190 PB(J) = SECTB + SLOPED * PB(J) + PREFF(J)
5560 .....
5561 .....
5562 .....
5563 .....
5564 .....
5565 .....
5566 .....
5567 .....
5568 .....
5569 .....
5570 .....
5571 .....
5572 .....
5573 .....
5574 .....
5575 .....
5576 .....
5577 .....
5578 .....
5579 .....
5580 .....
5581 .....
5582 .....
5583 .....
5584 .....
5585 .....
5586 .....
5587 .....
5588 .....
5589 .....
5590 .....
5591 .....
5592 .....
5593 .....
5594 .....
5595 .....
5596 .....
5597 .....
5598 .....
5599 .....
5600 .....
5601 .....
5602 .....
5603 .....
5604 .....
5605 .....
5606 .....
5607 .....
5608 .....
5609 .....
5610 .....
5611 .....
5612 .....
5613 .....
5614 .....
5615 .....
5616 .....
5617 .....
5618 .....
5619 .....
5620 .....
5621 .....
5622 .....
5623 .....
5624 .....
5625 .....
5626 .....
5627 .....
5628 .....
5629 .....
5630 .....
5631 .....
5632 .....
5633 .....
5634 .....
5635 .....
5636 .....
5637 .....
5638 .....

```

```

190 PB(J) = SECTB + SLOPED * PB(J) + PREFF(J)
.....
Approximate A-probe output.
.....
DO 195 I1 = 1,9,1
X1(I1) = YAMA(I1)
Y(I1) = PA(I1)
195 CALL MAT2 (9,5,COEF,-4)
DO 200 I1 = 1,9,1
200 PAC(I1) = FNP(4,COEF,YAMA(I1))
.....
FIND MAX. OUTPUT OF A PROBE.
.....
DX = 124.0
X0 = -40.0
205 DP = (FNP(4,COEF,X0) - FNP(4,COEF,(X0+DX)))
IF (ABS(DP) .LT. 0.001) GOTO 210
DPX = -2.0*COEF(3)*DX - 6.0*COEF(4)*X0*DX - 3.0*COEF(4)*DX*DX -
      12.0*COEF(5)*X0*DX*DX - 12*COEF(5)*X0*X0*DX - 4.0*COEF(5)*DX*DX
X0 = X0 - DP / DPX
GOTO 205
210 ASL = X0
ASR = X0 + DX
AAB = X0 + DX / 2.0
PAMAX = FNP(4,COEF,AAB)
PSAL = FNP(4,COEF,ASL)
PSAR = FNP(4,COEF,ASR)
PSA = (PSAL + PSAR) / 2.0
BETA = (PAMAX - PSA) / PAMAX
CPAMAX = (PAMAX - PSA) / (PTOTAL - PSA)
IF (IPRINT.NE.2HYES) GOTO 215
WRITE (LI,390) ASL,AAB,ASR,PSAL,PAMAX,PSAR,CPAMAX
IF (LO.NE.0) WRITE (LO,390) ASL,AAB,ASR,PSAL,PAMAX,PSAR,CPAMAX
215 CONTINUE
.....
APPROXIMATE B PROBE PRESSURES.
.....
DO 220 I1 = 1,9,1
X1(I1) = YAMB(I1)
Y(I1) = PB(I1)
220 CALL MAT2 (9,5,COEF,-4)
IF (IPRINT.NE.2HYES) GOTO 225
WRITE (LI,410)
IF (LO.NE.0) WRITE (LO,410)
225 CONTINUE
.....
CALCULATE AND PRINT QUALITY OF APPROXIMATIONS.
.....
DO 230 I1 = 1,9,1
PBC = FNP(4,COEF,YAMB(I1))
DPA = PA(I1) - PAC(I1)
DPB = PB(I1) - PBC
IF (IPRINT.NE.2HYES) GOTO 230
WRITE (LI,415) I1,YAMA(I1),PA(I1),PAC(I1),DPA,YAMB(I1),PB(I1),PBC,
      DPB
IF (LO.NE.0) WRITE (LO,415) I1,YAMA(I1),PA(I1),PAC(I1),DPA,
      YAMB(I1),PB(I1),PBC,DPB
230 CONTINUE
.....
FIND MAXIMUM OUTPUT OF B-PROBE.
.....
X0 = 10.00
235 DPX = FNP(4,COEF,X0)
IF (ABS(DPX) .LT. 0.001) GOTO 240
X0 = X0 - DPX / (2*COEF(3) + 6*COEF(4)*X0 + 12*COEF(5)*X0*X0)
GOTO 235
240 ABO = X0
PBMAX = FNP(4,COEF,ABO)
IF (IPRINT.NE.2HYES) GOTO 245

```

Figure J-2. Listing of Data Reduction Program &ABRED.
(Continued on next page.)

```

1639 WRITE (LI,395) ABO,PBMAX
1640 IF (LO.NE.0) WRITE (LO,395) ABO,PBMAX
1641
1642 245 CONTINUE
1643 CPBMAX = (PBMAX - PSA) / (PTOTAL - PSA)
1644 CPAMA = (CPAMA - CPBMAX) / CPAMA
1645
1646 XVEL = 0.0
1647 PHI = 0.0
1648 DO 250 I1 = 1,7,1
1649 DO 250 I2 = 1,7,1
1650 XVEL = XVEL + (COEX(I1,I2) * GAMMA(I2-1)) * BETAS(I1-1)
1651 PHI = PHI + (COEP(I1,I2) * GAMMA(I2-1)) * BETAS(I1-1)
1652 250 IF (IPRINT.NE.2) GOTO 265
1653 PSTAT = PAMA * (1 - XVEL * XVEL) ** 3.5
1654 WRITE (LI,420) PSTAT
1655 IF (LO.NE.0) WRITE (LO,420) PSTAT
1656 WRITE (LI,425)
1657 IF (LO.NE.0) WRITE (LO,425)
1658 DO 260 I1 = 1,9
1659 CPA = (PA(I1) - PSTAT) / (PAMA - PSTAT)
1660 YAW = YAMA(I1) - ABO
1661 WRITE (LI,430) I1,YAW,CPA
1662 IF (LO.NE.0) WRITE (LO,430) I1,YAW,CPA
1663
1664 260 CONTINUE
1665 265 CONTINUE
1666 PHI = PHI * 180 / 3.14159
1667 BETA2 = ATAN ((XU - XVEL * SIN(ABO * 3.14159 / 180)) *
1668 COS(PHI * 3.14159 / 180)) /
1669 ((XVEL * COS(ABO * 3.14159 / 180) * COS(PHI * 3.14159 / 180))) *
1670 180 / 3.14159
1671
1672 .....
1673 PRINT FLOW VECTOR QUANTITIES FOR INDIVIDUAL POSITIONS.
1674 .....
1675 WRITE (LI,435) I,BETA,GAMMA,XVEL,PHI,ABO,BETA2
1676 IF (LO.NE.0) WRITE (LO,435) I,BETA,GAMMA,XVEL,PHI,ABO,BETA2
1677 RDATA(1,I) = XVEL
1678 RDATA(2,I) = PHI
1679 RDATA(3,I) = ABO
1680 270 CONTINUE
1681
1682 .....
1683 STORE REDUCED DATA IN A DATA FILE.
1684 .....
1685 IL = 1536
1686 ISIZE(2) = 12
1687 WRITE (LI,440) NOLF
1688 READ (LI,440) IFILE,ISECU,ICR
1689 CALL CREAT (IDCB,IERR,IFILE,ISIZE,ITYPE,ISECU,ICR,IDCBS)
1690 IF (IERR.LT.0) WRITE(1,1111) JJ,IERR
1691 CALL OPEN (IDCB,IERR,IFILE,IOPTR,ISECU,ICR,IDCBS)
1692 JJ = 17
1693 IF (IERR.LT.0) WRITE(1,1111) JJ,IERR
1694 CALL WRIT (IDCB,IERR,RDATA,IL)
1695 JJ = 18
1696 IF (IERR.LT.0) WRITE(1,1111) JJ,IERR
1697 CALL CLOSE (IDCB,IERR,0)
1698 JJ = 19
1699 IF (IERR.LT.0) WRITE(1,1111) JJ,IERR
1700 WRITE (LI,445) IFILE,ICR
1701 IF (LO.NE.0) WRITE (LO,445) IFILE,ICR
1702 STOP 7777
1703
1704 END
1705 REAL FUNCTION FNP(NORDER,COEFF,ZX)
1706 REAL COEFF(7)
1707 A1 = COEFF(NORDER+1)
1708 IF (NORDER.EQ.0) GOTO 02
1709 DO 01 I = 1,NORDER,1
1710 I = NORDER + 1 - I
1711 01 A1 = COEFF(I) + ZX * A1
1712 FNP = A1
1713 RETURN
1714 END
1715 REAL FUNCTION FND(NORDER,COEFF,ZX)
1716 REAL COEFF(6)
1717 DO 01 I = 1,NORDER,1
1718 01 COEFF(I) = COEFF(I+1) * I
1719 A1 = COEFF(NORDER)
1720 NORDR = NORDER - 1
1721 IF (NORDR.EQ.0) GOTO 03
1722 DO 02 I = 1,NORDR,1
1723 I = (NORDR + 1) - I
1724 02 A1 = COEFF(I) + ZX * A1
1725 03 FND = A1
1726 RETURN
1727 END

```

Figure J-2. Listing of Data Reduction Program &ABRED.

APPENDIX K
PLOTT PROGRAMS FOR REDUCED DATA

The plot programs &PLOTX, &PLOTY and &PLOTP can be used to produce plots of the results obtained from the A and B probe. They are all almost identical except for which quantities of the flow vector they plot and the corresponding limits of the plots. Only one program description and one flow chart are given and the differences between the three programs are pointed out where they appear.

First, the program asks the user to key in the name of the data file containing the reduced data along with its cartridge reference number. This file is then read into an array DATA(3,256). The user has to decide whether he would like a plot on the X-Y plotter or just on the screen. Plots on the screen are much faster than those from the X-Y plotter and it is often only necessary to get a fast idea of the general value of the reduced data. However, X-Y plots are rather useful for documentation purposes. Once this decision is made either way, the use of the plot has to be specified. This must be done at any time the program is used. The physical dimensions of the plot have to be matched to the particular needs of the user.

Plot sizes have to be given in inches times ten. One inch is set equal to 25 millimeters (instead of 25.4 mm) by

the HP plotter software. The values of XMIN and YMIN (lower left corner of plot) should not be smaller than 5.0 (0.5 inches or 12.5 mm), in order to leave sufficient space for the line titles. It is advisable to scale the lengths of the axes in a way that even measures in inches correspond to even numbers of the quantities plotted. For example, 10 degrees in yaw angle equivalent to 1 inch. Following are the limits of the quantities to be plotted:

For all programs: $0 \leq \text{circumferential position} \leq 256$

Program PCOTX: $0.12 \leq X \text{ (Mach number equivalent)} \leq 0.20$

Program PCOTP: $-4^\circ \leq \text{pitch angle} \leq 16^\circ$

Program PCOTY: $10^\circ \leq \text{yaw angle} \leq 50^\circ$

Before the programs are used, the operator should check to see if his data falls within these limits. If it exceeds any limits, adjustments have to be made in the corresponding program line #67.

In order to compare different sets of data it is often helpful to plot the data from two or more files on one plot. To avoid having the same grid plotted any time one set of data is plotted, the user has to specify whether he wants to have a full grid (frame) plotted or not. He is also given a choice of 7 different line styles in order to distinguish similar but different data. For details of the line styles and plot software details see Ref. 11.

Once all this input is given the desired program will produce a plot as specified. In case of the X-Y plotter the number one pen is selected automatically by the program.

Thus the user should make sure that a good pen of the right color is inserted in that slot. When the complete graph is drawn, the program will stop.

Figure K-1 gives a flow chart of the program while Fig. K-2 is a program listing.

Eternals: CLOSE, DRAW, FXD, MOVE, OPEN, PLOTR, READF, SETAR, VIEWP, WINDW

<u>Variable</u>	<u>Type</u>	<u>Description</u>
DATA(3,256)	Real	Reduced data array
IBUM	Integer	Dummy variable
ICR	Integer	Cartridge reference number
ID	Integer	
IDCB(144)	Integer	Data control block
IDCBS	Integer	Control block length (of IDCB)
IDUM	Integer	Dummy variable
IFILE(3)	Integer	Array containing file name
IGCB(192)	Integer	Graphic data control block
IL	Integer	Total number of words to be stored in raw data file (two words for one data value)
ILINE	Integer	Line style determinator
ISECU	Integer	Security code
ISIZE(2)	Integer	Array to specify file dimensions (1st word for number of records, 2nd for record length)
ITYPE	Integer	Type of data file
LU	Integer	Output device number (screen/plotter)
X(256)	Real	Data array for X values

<u>Variable</u>	<u>Type</u>	<u>Description</u>
XMAX	Real	Maximum value of physical plot size (right side)
XMIN	Real	Minimum value of physical plot size (left side)
Y(256)	Real	Data array for Y values
YMAX	Real	Maximum value of physical plot size (upper limit)
YMIN	Real	Minimum value of physical plot size (lower limit)

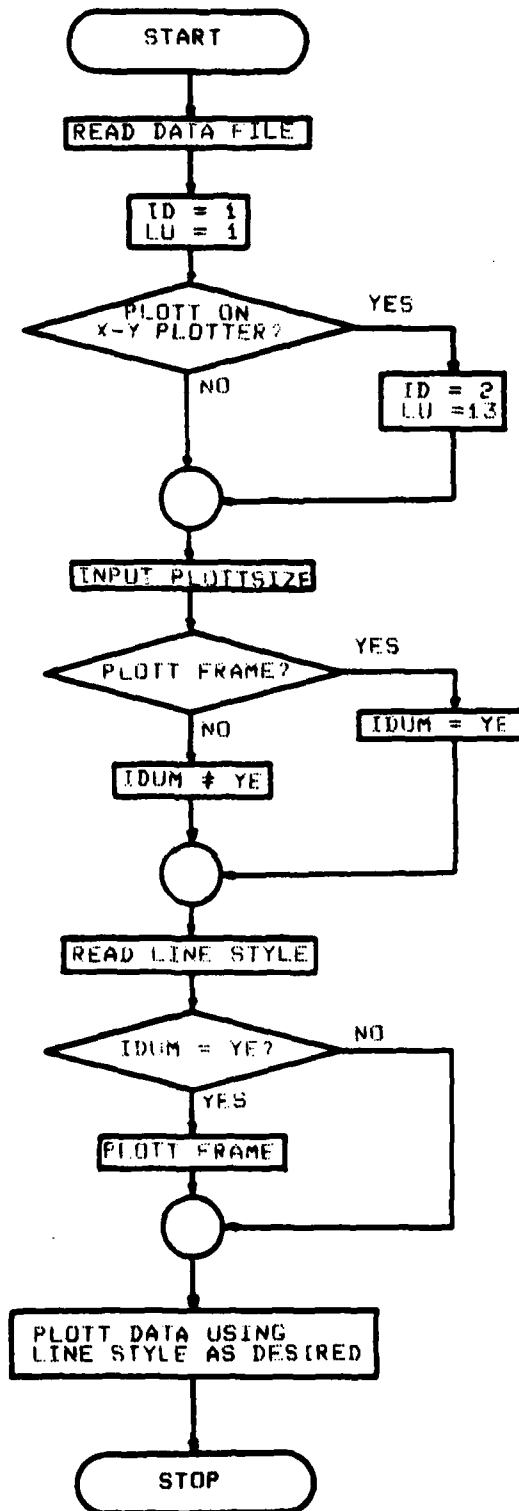

Figure K-1. Flow Chart of Plot Programs &PLOTX, &PLOTY or &PLOTP.

```

PLOTX T=00004 IS ON CR00026 USING 00014 BLKS R=0000
001 FTN4,L
002 PROGRAM PLOTX (3,99)
003
004 C
005 THIS IS PROGRAM PLOTX(ve1)
006
007 C
008 IT PLOTS X (MACHNUMBER) DISTRIBUTIONS AS ESTABLISHED WITH
009 PROGRAM ABRED.
010 X IS EQUIVALENT TO MACHNUMBER AND GIVEN AS A FUNCTION OF
011 CIRCUMFERENTIAL POSITION.
012 C
013 ACTUAL PLOTFSIZE IS USER INPUT.
014 C
015
016 DIMENSION IGCB(170)
017 REAL DATA(4,256) X(256),Y(256)
018 INTEGER IDCB(144),IFILE(3),ISIZE(2)
019 DATA IDCBS / 144/
020 DATA ISECU / 00/
021 DATA ITYPE / 1/
022 DATA IL / 2048/
023 DATA ISIZE(1) / 16/
024 DATA ISIZE(2) / 128/
025 100 FORMAT ("Enter the name of the data file!")
026 101 FORMAT ("Enter the CR number!")
027 102 FORMAT (" If you want the plot on the plotter, key PL, anythingels
028 as for the terminal!")
029 103 FORMAT ("Enter Xplotmin !")
030 104 FORMAT ("Enter Xplotmax !")
031 105 FORMAT ("Enter Yplotmin !")
032 106 FORMAT ("Enter Yplotmax !")
033 107 FORMAT (" Do you need a complete new frame?/" Answer YES or NO!")
034 108 FORMAT (" Enter line style (0 - 6) !")
035 149 FORMAT ("STATEMENT 0 : "13" ERROR 0 : "14" DETECTED")
036 1111 LI = LOCLU(ISECU)
037 WRITE (LI,100)
038 READ (LI,149) IFILE
039 WRITE (LI,101)
040 READ (LI,*) ICR
041 CALL OPEN (IDCB,IERR,IFILE,IOPTR,ISECU,ICR,IDCBS)
042 JJ = 1
043 IF (IERR .LT. 0) WRITE (LI,1111) JJ,IERR
044 CALL READP (IDCB,IERR,DATA,IL,LEN,1)
045 JJ = 2
046 IF (IERR .LT. 0) WRITE (LI,1111) JJ,IERR
047 JJ = 3
048 CALL CLOSE (IDCB,IERR,0)
049 IF (IERR .LT. 0) WRITE (LI,1111) JJ,IERR
050 LU = 1
051 ID = 1
052 WRITE (LI,102)
053 READ (LI,149) IDUM
054 IF (IDUM .EQ. 2MPL) ID = 2
055 IF (ID .EQ. 3) LU = 13
056 WRITE (LI,103)
057 READ (LI,*) XMIN
058 WRITE (LI,104)
059 READ (LI,*) XMAX
060 WRITE (LI,105)
061 READ (LI,*) YMIN
062 WRITE (LI,106)
063 READ (LI,*) YMAX
064 CALL PLOTX (IGCB,ID,1,LU)
065 CALL SETAR (IGCB,1.5)
066 CALL VIEWP (IGCB,XMIN,XMAX,YMIN,YMAX)
067 CALL WINDW (IGCB,0.0,256.0,0.18,0.24)
068 WRITE (LI,107)
069 READ (LI,149) IDUM
070 WRITE (LI,108)
071 READ (LI,*) ILINE
072 CALL LINE (IGCB,ILINE)
073 IF ( IDUM .NE. 2NVE ) GOTO 05
074 CALL FXD (IGCB,2)
075 CALL PEN (IGCB,1)
076 CALL LGRID (IGCB,-16.,.01,0.0,0.12,4.0,2.0,1.0)
077 05 CONTINUE
078 CALL MOVE (IGCB,0.0,DATA(1,1))
079 DO 10 I = 1,256
080 CALL DRAW (IGCB,XJ,DATA(1,I))
081 STOP 7777
082 END
083

```

Figure K-2. Listing of Reduced Data Plott Program &PLOTX.

LIST OF REFERENCES

1. F. Neuhoff, "Calibration and Application of a Combination Temperature-Pneumatic Probe for Velocity and Rotor Loss Distribution Measurements in a Compressor," Contractor's Report No. NPS67-81-03CR, December 1981.
2. R. P. Shreeve, J. M. Simmons, J. C. West, Jr., and K. A. Winters, "Determination of Transonic Compressor Flow Field by Synchronised Sampling of Stationary Fast Response Transducers," (Winter Annual Meeting of the Society of Mechanical Engineers, San Francisco, CA, December 1978).
3. R. P. Shreeve, A. G. McGuire and J. A. Hammer, "Calibration of a Two Probe Synchronised Sampling Technique for Measuring Flows Behind Rotors," ICIASF'79 Record, IEEE 79CH1500-8AES.
4. McCarville, P. A., "Hardware and Software Improvement to a Paced Data Acquisition System for Turbomachines," Master's Thesis, Naval Postgraduate School, Monterey, CA, June 1981.
5. Frank S. Cina, "Subsonic Cascade Wind Tunnel Tests Using a Compressor Configuration of DCA Blades," Master's Thesis, Naval Postgraduate School, Monterey, CA, June 1981.
6. H. Zebner, "Procedure and Computer Program for the Approximation of Data (with Application to Multiple Sensor Probes)," Contractor's Report No. NPS67-80-001CR, August 1980.
7. H. Weyer, "Bestimmung der zeitlichen Druckmittelwerte in stark fluktuierender Stromung, insbesondere in Turbomaschinen," [The Determination of Time-Weighted Average Pressures in Strongly Fluctuating Flows, Especially in Turbomachines], Deutsche Forschungs- und Versuchsanstalt fur Luft- und Raumfahrt, Forschungsbericht 74-34, (1974).
8. L. N. Krause, T. J. Dudzinski and R. C. Johnson, "Total Pressure Averaging in Pulsating Flows, Instrumentation for Airbreathing Propulsion," edited by A. E. Fuhs and M. Kingery for AIAA series, Progress in Astronautics and Astronautics, Volume 34, M.I.T. Press, (1974).
9. S. H. Chue, "Pressure Probes for Fluid Measurement," Prog. Aerospace Sci., 1975, Vol. 16, No. 2, pp. 147-223, Pergamon Press. Printed in Great Britain.
10. D. W. Byer and R. C. Pankhurst, "Pressure-probe methods for Determining Wind Speed and Flow Direction," National Physical Laboratory.
11. HP 92840A Graphics Plotting Software, Manual Part No. 92840-90001, Printed in U.S.A. April 1980.

DISTRIBUTION LIST

	<u>No. of Copies</u>
1. Library Code 0212 Naval Postgraduate School Monterey, CA 93943	4
2. Office of Research Administration Code 012A Naval Postgraduate School Monterey, CA 93943	1
3. Chairman Code 67 Department of Aeronautics Naval Postgraduate School Monterey, CA 93943	1
4. Director, Turbopropulsion Laboratory Department of Aeronautics Naval Postgraduate School Monterey, CA 93943	15
5. Mr. George Derderian Naval Air Systems Command Code Air-310E Navy Department Washington, DC 20360	1
6. Commanding Officer Naval Air Propulsion Test Center Attn: Mr. Vernon Lubosky Trenton, New Jersey 08628	1
7. National Aeronautics & Space Administration Lewis Research Center (Library) 2100 Brookpark Road Cleveland, Ohio 44135	1
8. Library General Electric Company Aircraft Engine Technology Division DTO Mail Drop H43 Cincinnati, Ohio 45215	1

9. Library 1
Pratt and Whitney Aircraft
Post Office Box 2691
West Palm Beach, Florida 33402
10. Library 1
Pratt and Whitney Aircraft
East Hartford, Connecticut 06108
11. Library 1
Air Research Mfg. Corporation
Division of Garrett Corporation
402 South 36th Street
Phoenix, Arizona 85034

