

AD-A136 055

FRACTURE BEHAVIOR UNDER IMPACT(U) FRAUNHOFER-INST FUER
WERKSTOFFMECHANIK FREIBURG (GERMANY F R)
J F KALTHOFF ET AL. JUL 82 W-9/83 DAJA37-81-C-0013

1/1

UNCLASSIFIED

F/G 20/11

NL

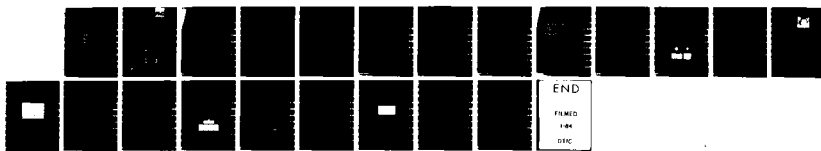

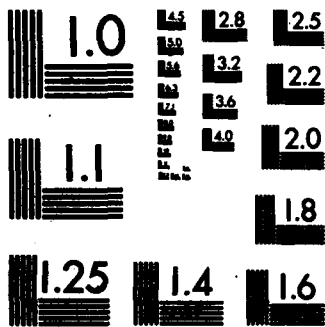

MICROCOPY RESOLUTION TEST CHART
NATIONAL BUREAU OF STANDARDS-1963-A

AD A136 055

FhG

5

Fraunhofer-Gesellschaft

FRACTURE BEHAVIOR UNDER IMPACT

W 9/83

2nd Semi-Annual Progress Report

by

J.F. Kalthoff and S. Winkler

Reporting Period Feb. 1982 - July 1982

DISTRIBUTION STATEMENT A

**Approved for public release;
Distribution Unlimited**

DTIC

DEC 19 1983

H

DTIC FILE COPY

**Fraunhofer-Institut
für Werkstoffmechanik**

83 12 19 154

FRAUNHOFER-INSTITUT FOR WERKSTOFFMECHANIK
Wöhlerstr. 11, D-7800 Freiburg

FRACTURE BEHAVIOR UNDER IMPACT
W 9/83
2nd Semi-Annual Progress Report
by
J.F. Kalthoff and S. Winkler
Reporting Period Feb. 1982 - July 1982

United States Army
EUROPEAN RESEARCH OFFICE OF THE U.S. Army
London England

CONTRACT NUMBER DAJA 37-81-C-0013

The Research reported in this document has been made possible through the support and sponsorship of the U.S. Government through its European Research Office of the U.S. Army. This report is intended only for the internal management use of the Contractor and the U.S. Government.

SECURITY CLASSIFICATION OF THIS PAGE (When Data Entered)

REPORT DOCUMENTATION PAGE		READ INSTRUCTIONS BEFORE COMPLETING FORM
1. REPORT NUMBER	2. GOVT ACCESSION NO.	3. RECIPIENT'S CATALOG NUMBER
	AD-A136 055	
4. TITLE (and Subtitle)	5. TYPE OF REPORT & PERIOD COVERED	
Fracture Behavior Under Impact	2nd Semi-Annual Progress Report	
	6. PERFORMING ORG. REPORT NUMBER	
7. AUTHOR(s)	8. CONTRACT OR GRANT NUMBER(s)	
J. F. Kalthoff and S. Winkler	DAJA37-81-C-0013	
9. PERFORMING ORGANIZATION NAME AND ADDRESS	10. PROGRAM ELEMENT, PROJECT, TASK AREA & WORK UNIT NUMBERS	
Fraunhofer-Institut für Werkstoffmechanik Wöhlerstr 11, 7800 Freiburg/Brsg West Germany	6.11.02A IT161102BH57-06	
11. CONTROLLING OFFICE NAME AND ADDRESS	12. REPORT DATE	
USARDSG-UK Box 65 FPO NY 09510	Feb 82 - July 82	
	13. NUMBER OF PAGES	
	17	
14. MONITORING AGENCY NAME & ADDRESS (if different from Controlling Office)	15. SECURITY CLASS. (of this report)	
	Unclassified	
	15a. DECLASSIFICATION/DOWNGRADING SCHEDULE	
16. DISTRIBUTION STATEMENT (of this Report)		
Approved for public release; distribution unlimited		
17. DISTRIBUTION STATEMENT (of the abstract entered in Block 20, if different from Report)		
18. SUPPLEMENTARY NOTES		
19. KEY WORDS (Continue on reverse side if necessary and identify by block number)		
Impact loading, Multiple cracks, high strength steel, rapid crack , Impact velocities, rapid crack propagation		
20. ABSTRACT (Continue on reverse side if necessary and identify by block number)		
<p>→ The physical behavior of cracks under impact loading is investigated. Single edge cracks or arrays of multiple cracks in rectangular specimens are considered. The specimens are loaded by time dependent tensile stress pulses moving perpendicular to the crack direction. The specimens are either directly loaded by an impinging projectile or by a base plate which is accelerated by the projectile. The specimens are made from a transparent model material or a high strength steel. The initial crack lengths and impact velocities are varied throughout the experiments. Utilizing the</p>		

Accession For

NTIS GRA&I DTIC TAB Unannounced

Justification

By

Distribution/

Availability Codes

A11 and/or

Dist Special

A1



UNCLASSIFIED

SECURITY CLASSIFICATION OF THIS PAGE(When Data Entered)

shadow optical method of caustics in combination with high speed photography, the dynamic stress intensity factors at the tip of the crack are measured as functions of time during the impact event. The critical value of the dynamic stress intensity factor at onset of rapid crack propagation, i.e. the dynamic fracture toughness K_{Id} , is determined and discussed with regard to the time t_f at which the crack becomes unstable. The results are compared with corresponding static fracture toughness data.

AD-7517
UNCLASSIFIED

UNCLASSIFIED

SECURITY CLASSIFICATION OF THIS PAGE(When Data Entered)

1. TECHNICAL OBJECTIVES

The physical behavior of cracks under impact loading is investigated. Single edge cracks or arrays of multiple cracks in rectangular specimens are considered. The specimens are loaded by time dependent tensile stress pulses moving perpendicular to the crack direction. The specimens are either directly loaded by an impinging projectile or by a base plate which is accelerated by the projectile. The specimens are made from a transparent model material or a high strength steel. The initial crack lengths and impact velocities are varied throughout the experiments. Utilizing the shadow optical method of caustics in combination with high speed photography, the dynamic stress intensity factors at the tip of the crack are measured as functions of time during the impact event. The critical value of the dynamic stress intensity factor at onset of rapid crack propagation, i.e. the dynamic fracture toughness K_{ID} , is determined and discussed with regard to the time t_f at which the crack becomes unstable. The results are compared with corresponding static fracture toughness data.

2. STATEMENT OF WORK

During the first year of the three year's research project the experimental set-up has been built up. Experiments were performed to test the set-up under different loading conditions. In particular the stress pulse history in the specimen has been studied. Several series of experiments have been performed to specify the parameters for the main investigations. Within this reporting period, i.e. the first half of the second year, the main investigations have been started.

Experiments have been performed with specimens made from the model material Araldite B directly impacted by a projectile made from the same material. The fracture behavior of single edge cracks of different lengths was investigated. In particular the dynamic fracture toughness values K_{ID} and the times to fracture t_f have been measured. These data were supplemented by experiments performed under base plate loading conditions. The impact velocities have been varied from about 10 to 40 m/s. The limited results ob-

tained so far do not allow definite conclusions at this state of the project. More data will be generated in the next reporting period and will be reported and discussed in the Second Annual Report.

Additional experiments have been carried out to study the interaction of multiple cracks under dynamic loading. A double crack configuration with a distance between the cracks which is almost equal to the length of the cracks has been investigated. The data indicate a complex time dependent mutual interaction of the cracks. Further experiments with other geometric conditions will be performed in the next reporting period.

First quantitative results obtained within the research project have been presented at the "Workshop on Dynamic Fracture Modeling and Quantitative Analysis", Baltimore, May 17-19, 1982. The workshop has been organized by J.R. Moss, Ballistic Research Laboratory, Aberdeen. The investigator presented the following lectures: "Introduction to Fracture Mechanics", "Shadow Optical Analysis of Dynamic Fracture Phenomena", and "Short Pulse Fracture Mechanics" (in cooperation with D.A. Shockey, SRI-International, Menlo Park, Calif.). For further details see Trip Report "Participation in Workshop on Dynamic Fracture Modeling and Quantitative Analysis" by J.F. Kalthoff prepared for Dr. B. Steverding, Aeronautics and Mechanics Branch, European Research Office of the U.S. Army, London. Another presentation of results is planned for the VII. International Conference on "Experimental Stress Analysis", Haifa, Israel, August 23-28, 1982. The manuscript of the material to be presented has been completed. A copy of the manuscript is attached to this Report in the Annex.

3. NEXT STEPS

According to the proposed research program the investigations with Araldite B specimens will be continued throughout the second year. Further data will be generated on the dependence of the impact fracture toughness $K_{I D}$ with loading rate and the mutual interaction of multiple cracks under dynamic loading. For the third year experiments with high strength steel specimens are planned.

ANNEX

**PROCEEDINGS OF THE
SEVENTH INTERNATIONAL CONFERENCE ON**

EXPERIMENTAL STRESS ANALYSIS

HAIFA, ISRAEL, 23-27 AUGUST, 1982

**Under the Auspices of the
European Permanent Committee for Stress Analysis
With the Cooperation of the
Society for Experimental Stress Analysis (S.E.S.A.)
and Sponsored by
The Technion, Israel Institute of Technology, Haifa, Israel**

ANALYSIS OF IMPACT FRACTURE PHENOMENA BY MEANS OF THE SHADOW OPTICAL METHOD OF CAUSTICS

J. F. Kalthoff, W. Böhme, and S. Winkler

Fraunhofer-Institut für Werkstoffmechanik
Rosastrasse 9
7800 Freiburg/Brsg., West-Germany

Abstract

The shadow optical method of caustics is applied for investigating the fracture behavior of cracks under impulse loads. The loads are produced by a drop weight or by an impinging projectile. Results on the dynamic stress intensity factors before, at, and after onset of crack propagation are discussed for the different loading rates obtained.

1. Introduction

In static fracture mechanics crack tip stress intensity factors can easily be determined from external measurements of loads or displacements. In fracture dynamics the situation is more complex due to additional time effects. Correct dynamic stress intensity factors are obtained by directly evaluating the local stress strain field around the crack tip. The shadow optical method of caustics is an appropriate experimental tool for measuring stress intensifications since the method is sensitive to stress gradients near the crack tip. The physical principles of the caustic technique are described. The method is applied to analyse the fracture behavior of cracks under different conditions of impact loading.

2. The Shadow Optical Method of Caustics

The method of caustics was originally introduced by Manogg [1,2] in 1964. Later on, Theocaris [3] further developed the technique. The authors and their coworkers extended and applied Manogg's method for investigating dynamic fracture phenomena [4-8].

The physical principle of the method is illustrated in Fig. 1. A pre-cracked specimen of a transparent material under load is illuminated by a parallel light beam. A cross section through the specimen at the crack tip is shown in Fig. 1b. Due to the stress concentration at the crack tip

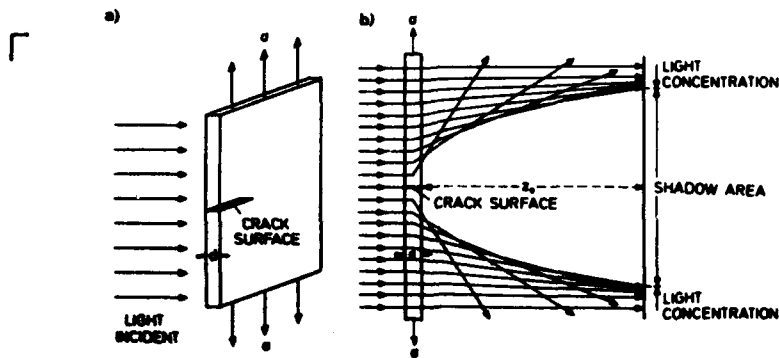

Fig. 1 Physical principle of the shadow optical method of caustics

both the thickness of the specimen and the refractive index of the material are reduced. Thus, the area surrounding the crack tip acts as a divergent lens and the light rays are deflected outwards. As a consequence, in an image plane at a distance z_0 behind the specimen a shadow area is observed which is surrounded by a region of light concentration, the caustic. For optically isotropic materials a single caustic is obtained, for optically anisotropic materials the caustic splits up into a double caustic. The method can also be applied with non-transparent materials such as steels when used in reflection.

The mode I shadow pattern was calculated by Manogg [1] from the linear elastic stress strain field around the crack tip. Fig. 2 compares the results with shadow patterns photographed in transmission and in reflection with different materials. Quantitatively the diameter of the

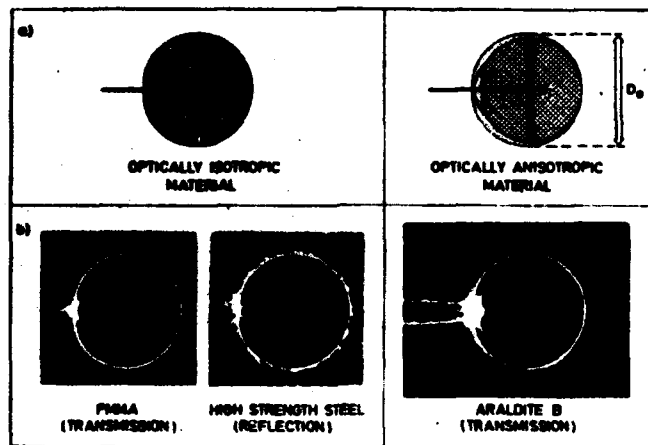

Fig. 2 Mode I caustics

caustic is a function of the stress intensity factor,

$$K_I = \frac{2\sqrt{2\pi}}{3 f_{0,i}^{5/2} c d_{eff} z_0} D_{0,i}^{5/2} \quad (1)$$

where

- K_I = Mode I stress intensity factor,
- $D_{0,i}$ = diameter of the outer/inner caustic,
- $f_{0,i}$ = numerical factor for outer/inner caustic,
- c = photoelastic constant,
- d_{eff} = effective specimen thickness,
- d = total specimen thickness,
- z_0 = distance between specimen and image plane.

Numerical values of the constants which appear in formula (1) are given in Table 1 for different materials. The formula is correct for stationary cracks under both static and dynamic loading conditions, but it can also be applied for propagating cracks with an accuracy sufficient for engineering purposes. Further details are given in [8,9].

TABLE 1 - Constants for Caustic Evaluation

Material	Elastic Constants		Shadow Optical Constants						Effective Thickness
	Young's Modulus MN/m ²	Poisson's Ratio	for Plane Stress			for Plane Strain			
			c m ² /N	f ₀	f ₁	c m ² /N	f ₀	f ₁	
TRANSMISSION: (z₀ = 0)									
Optically Anisotropic:									
Araldite B	3680	0.382	-0.970 × 10 ⁻¹⁰	3.31	3.05	-0.580 × 10 ⁻¹⁰	3.41	2.98	d
CR-39	2980	0.443	-1.200 × 10 ⁻¹⁰	3.25	3.10	-0.580 × 10 ⁻¹⁰	3.33	3.04	d
Pyrex Glass	73900	0.231	-0.027 × 10 ⁻¹⁰	3.43	2.98	-0.017 × 10 ⁻¹⁰	3.62	2.97	d
Heraclite 180	4820	0.310	-0.920 × 10 ⁻¹⁰	3.23	3.11	-0.787 × 10 ⁻¹⁰	3.24	3.10	d
Optically Isotropic:									
PMMA	3340	0.350	-1.080 × 10 ⁻¹⁰	3.17	-	-0.750 × 10 ⁻¹⁰	3.17	-	d
REFLECTION: (z₀ > 0)									
All materials	E	ν	2ν/E	3.17	-	-	-	-	d/2

For cracks subjected to a combined mode I mode II loading the caustic becomes unsymmetric, as it is shown in Fig. 3. The stress intensity factors K_I and K_{II} are then determined by the two diameters D_{max} and D_{min} defined in the figure [10,11].

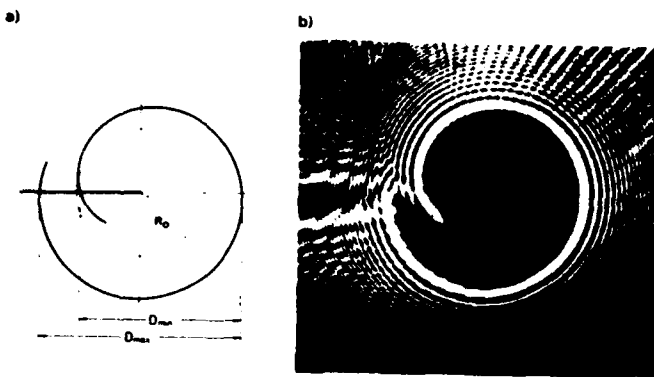

Fig. 3 Mode I mode II caustics (a - calculated, b - measured)

3. Experimental Procedure

Two kinds of impact experiments have been performed. Prenotched specimens were loaded by a drop weight or by an impinging projectile. A schematic view of the loading arrangements is given in Fig. 4. The mechanical aspects of the fracture behavior were studied in these experiments; in particular the loading conditions at the tip of the stationary crack during impact and for parts of the subsequent crack propagation event were considered.

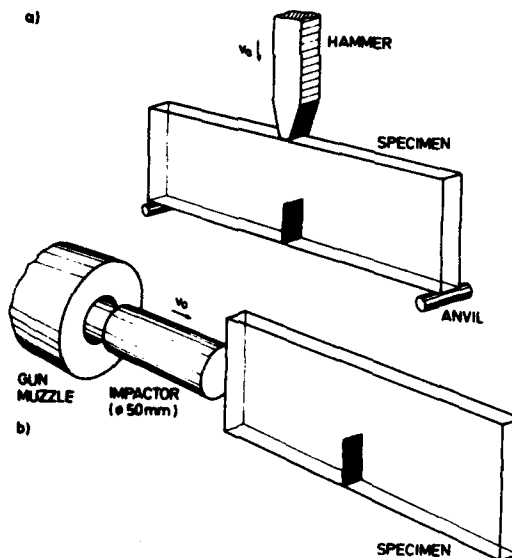

Fig. 4 Loading arrangements (a - drop weight loading, b - impinging projectile)

The specimens were made from a model material, the epoxy resin Araldite B. This material is well suited for dynamic investigations since the mechanical and optical properties of the material vary only very little with loading rate [8]. Either naturally sharp cracks or blunted notches were utilized. The shadow optical technique was applied in transmission. The caustics were photographed with a Cranz-Schardin 24 spark high speed camera. Prior to impact the drop weight or the projectile interrupts a laser beam thus providing the signal to trigger the high speed camera. A typical series of shadow optical photographs is given in Fig. 5. Only 12 of the total 24 pictures are reproduced. The photographs show the precracked center part of a specimen loaded by an impinging projectile (see also Fig. 10).

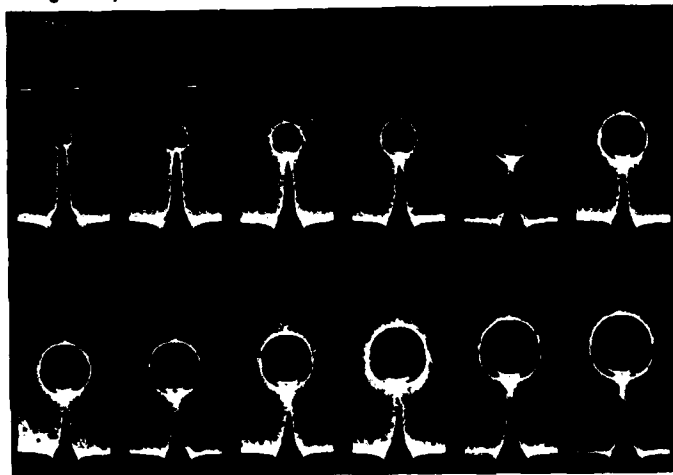

Fig. 5 Shadow optical photographs of a precracked specimen loaded by an impinging projectile (see also Fig. 10)

3.1 Drop weight loading

Specimens of size 650 x 118 x 10 mm with initial notches of 35 mm were impacted by a drop weight of 1.4 kg at a velocity v_0 of 5 m/s. The support span was 472 mm. The results of two experiments are shown in Fig. 6. The dynamic stress intensity factor K_I^{dyn} (upper diagram) and the crack length a (lower diagram) are plotted as functions of time t . The times are given in absolute units and in two relative units, T_L and τ . T_L is the time it would take a longitudinal wave to travel a distance given by the crack length a . τ is the period of the oscillation of the impacted bend specimen determined by a formula given by Ireland [12]. In addition

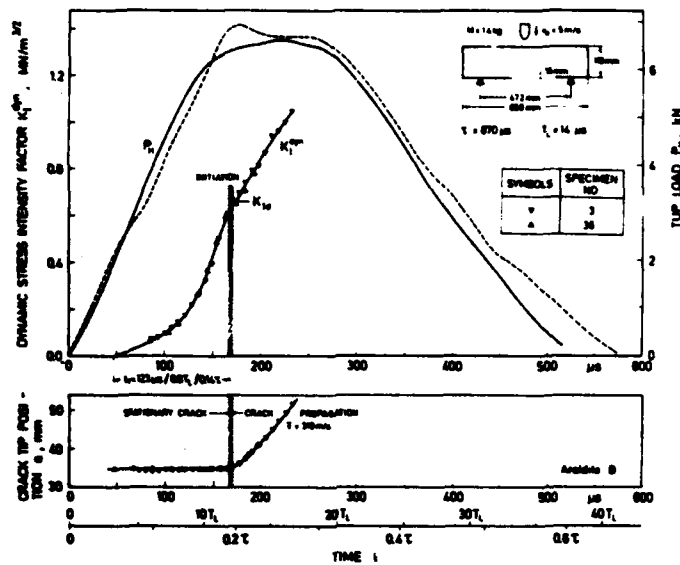

Fig. 6 Fracture behavior of a precracked bend specimen under drop weight loading

to the stress intensity factor the load P_H measured by a strain gage at the tip of the striking hammer is also shown in Fig. 6.

The start of the stress intensity factor curve is delayed with regard to the load curve. This is due to the different wave propagation paths between the point of impact and the positions where the respective signals were recorded. The critical stress intensity factor for onset of crack propagation, i.e. the dynamic fracture toughness K_{ID} , is about $0.67 \text{ MN/m}^{3/2}$. This value is only somewhat smaller than the static fracture toughness $K_{IC} = 0.70 \text{ MN/m}^{3/2}$ for this batch of material. The time to fracture t_f measured from the beginning of crack tip loading til the point of onset of propagation is $123 \mu s$ or $8.8 T_L$ or 0.14τ . After the crack has become unstable the crack velocity steadily increases up to a rather high value of 310 m/s . During this phase of crack propagation the dynamic stress intensity factor continues to grow, but the slope of the $K_I^{dyn}(t)$ -plot after crack initiation is less steep than before instability.

In instrumented impact tests the dynamic fracture toughness K_{ID} is usually determined from the hammer load at the moment of instability, $P_H(t=t_f)$, utilizing conventional static stress intensity factor formu-

las originally derived for bend specimens subjected to quasistatic loading. If $K_{I,d}$ would be calculated in a formal manner according to this procedure an unrealistically high value of $12 \text{ MN/m}^{3/2}$ would be obtained [13]. This result indicates the strong influence of dynamic (inertia) effects associated with impact experiments, in particular for short times to fracture ($t_f < \tau$).

Further experiments have been performed with an increased observation time. Fracture was delayed by utilizing blunted initial notches and a rather low impact velocity of 0.5 m/s. The experiments have been performed with specimens of size $412.5 \times 75 \times 10 \text{ mm}$ which were struck by a hammer of 4.9 kg at a support span of 300 mm. In Fig. 7 the shadow optically determined dynamic stress intensity factors are shown during loading of the stationary crack for times up to about 5τ . These data are compared to the static stress intensity factor $K_I^{\text{dyn}}(P_H)$ calculated from the load P_H registered at the tup of the striking hammer utilizing conventional static stress intensity factor formulas from ASTM E 399

The K_I^{stat} -values show a strongly oscillating behavior, whereas the actual dynamic stress intensity factors K_I^{dyn} show a more steadily increasing tendency. For small times these differences are very pronounced, in particular $K_I^{\text{stat}} \ll K_I^{\text{dyn}}$ (see before). With increasing time, the differences become smaller but within the observation time the influences of dynamic effects obviously did not vanish and there are still marked differences between K_I^{stat} and K_I^{dyn} . In a method for measuring the dynamic fracture toughness values $K_{I,d}$ in instrumented impact tests [14] it is assumed that for times larger than 3τ K_I^{stat} -values would represent a good approximation of the actual dynamic stress intensity factor K_I^{dyn} . These data, however, indicate that a static analysis is not adequate to describe the loading condition in the specimen, even for times $t > 3\tau$.

All drop weight experiments showed an interesting feature in their crack propagation paths. At the end of the crack propagation event the crack propagation direction was not straight any more, but a characteristic deviation to the left or to the right hand side of the original crack path was observed. Herrmann [15] speculated that this behavior results from stress waves reflected at the free ends of the specimen. The effect obviously depends on the time for the crack to propagate through the specimen: the deviation becomes more pronounced for faster propagating cracks initiated from notches of increased bluntness. The change of the

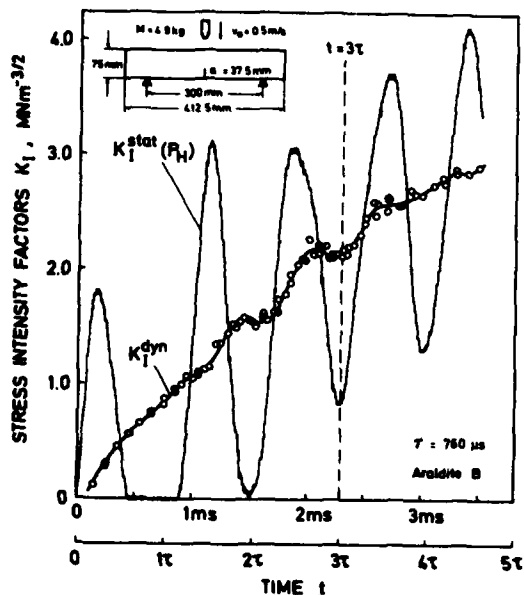

Fig. 7 Stress intensity factors for a prenotched bend specimen under drop weight loading

straight to the curved phase of crack propagation has been analyzed by the shadow optical technique. The high speed photographs indicate a very low, almost zero crack velocity at this moment. A typical shadow pattern is shown in Fig. 8a. The shape of the caustic is unsymmetric and indicates a mode II loading superimposed to the original mode I

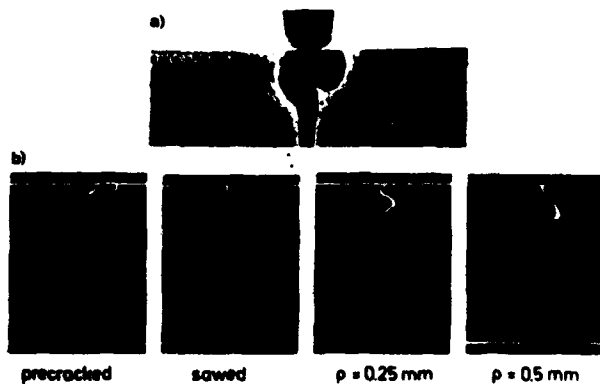

Fig. 8 On the direction of crack propagation under drop weight loading (a - mixed mode caustic, b - crack paths)

loading. Due to this mixed mode loading the crack deviates from its original direction in the subsequent step of crack propagation.

3.2 Impinging projectile

Specimens of size 400 x 100 x 10 were impacted by a projectile of 200 mm length and 50 mm diameter. The length of the initial crack was 26.5 mm. Both specimen and projectile were made from the same material, Araldite B. The projectile was accelerated by a gas gun operated at a very low gas pressure. Thus, the impact velocities in these experiments were in the range of 10 m/s only. By the impinging projectile a compressive stress wave is initiated which propagates into the specimen. After passage of the compressive stress pulse through the specimen and reflection at the free rear end of the specimen the crack is loaded by tensile stresses. Shadow optical recordings of these processes have been made by Theocaris et al. [16]. Information on the gross loading condition in the specimen at the location of the crack was obtained from a strain gage which was positioned on the ligament 47 mm ahead of the crack tip (Position A). A typical strain gage signal is shown in Fig. 9. The arrival time of the compressive stress pulse at the location of the strain gage has been set equal to zero in this diagram. For a period of 280 μ s the crack is loaded by compressive stresses; only later on tensile stresses are built up. The crack tip behavior under tensile loading was studied by caustics. The high speed camera was operated with a suitable delay

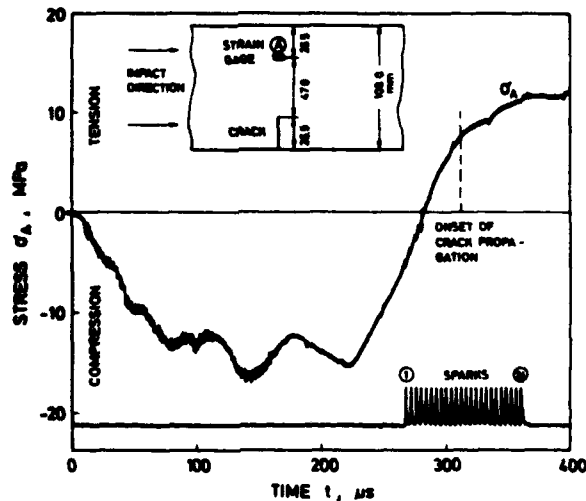

Fig. 9 Stress pulse produced by an impinging projectile

time; the recording times of the 24 shadow optical pictures are shown in Fig. 9 also.

Quantitative data of the shadow optical photographs (see Fig. 5) are given in Fig. 10. The dynamic stress intensity factor K_I^{dyn} (upper diagram) and the crack length a (lower diagram) are given as functions of time t . Similar as in Fig. 6 the times are given in absolute units but also in relative units by normalization with the time T_L . For comparison the load record from the strain gage is also shown in Fig. 10. Due to

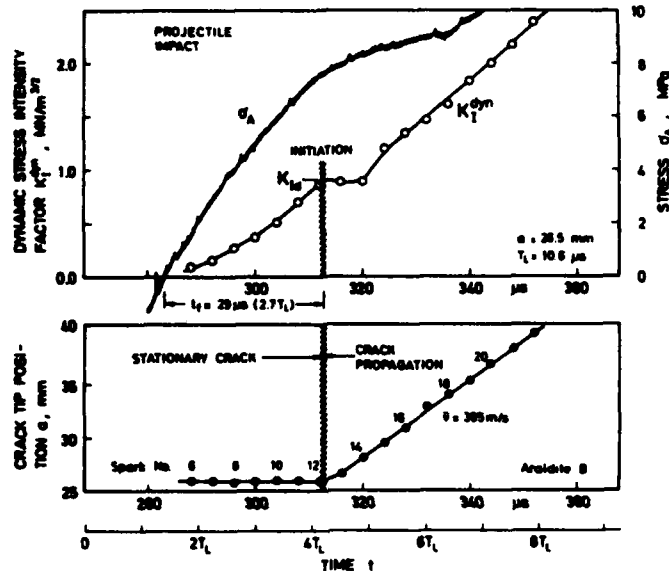

Fig. 10 Fracture behavior of a precracked specimen loaded by an impinging projectile

inertia effects the loads $\sigma_A(t)$ and the dynamic stress intensity factors $K_I^{dyn}(t)$ are not proportional to each other. As with drop weight experiments K_{I_d} -values calculated in a formal manner from the stress $\sigma_A(t=t_f)$ at the moment of instability utilizing conventional static stress intensity factor formulas would severely overestimate the toughness of the material. The shadow optically determined values of the critical stress intensity factor for onset of crack propagation were realistic. But the scatter of data obtained in a series of experiments with similar impact velocities was rather large. In particular K_{I_d} -values larger than the static fracture toughness K_{I_C} were obtained (see also Fig. 10). The time to fracture was considerably smaller in these

experiments than in the drop weight experiments, $t_f = 29 \mu\text{s}$ or $2.7 T_L$, i.e. the time to fracture became comparable to the information time of the crack length. It is speculated that stress intensity factors larger than K_{IC} might result for such experiments with very high loading rates because of incubation times which are needed to activate the instability process. This speculation would be in accordance with a short pulse fracture criterion developed by Kalthoff and Shockey in a previous publication [17]. More experiments are necessary to investigate these phenomena.

The onset of crack instability is clearly indicated in the crack length-time plot. Within a very short period of time after instability the crack has reached a very high steady state velocity \bar{v} of 365 m/s. For some time after the moment of crack initiation the slope of the $K_I^{\text{dyn}}(t)$ -plot is as steep as before crack instability. Due to the high crack propagation velocity and the steep increase of the dynamic stress intensity factor

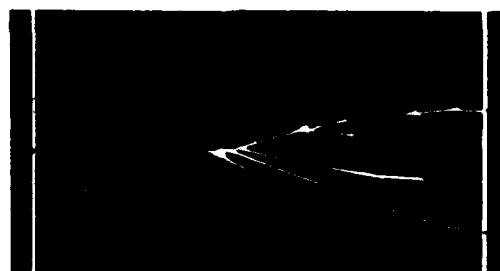

Fig. 11 Crack branching observed under projectile loading

with time the fracture behavior is different from the one obtained with drop weight experiments. Crack branching (see fig. 11) is observed in almost all the experiments after a relatively short phase of crack propagation.

4. Summary and Conclusions

The applicability of the shadow optical method of caustics for determining dynamic stress intensity factors has been demonstrated. Several aspects of the fracture behavior of cracks loaded by a drop weight or by an impinging projectile have been investigated. The stress intensification rates and the resulting fracture behavior were different for the two conditions of impact loading. Even for the lower loading rates obtained with drop weight experiments a strong influence of dynamic effects on the loading condition before, at, and after crack instability can re-

sult. Further information is necessary to fully understand the dynamic processes associated with the fast impact loading of cracks.

Acknowledgement

The work reported in this paper is sponsored by the Deutsche Forschungsgemeinschaft under Contracts Ka 443/3-10 and by the European Research Office of U.S. Army under Contract DAJA37-81-C-0013.

5. References

1. Manogg, P., "Anwendung der Schattenoptik zur Untersuchung des Zerreißvorgangs von Platten", Dissertation, Freiburg, Germany, 1964.
2. Manogg, P., "Schattenoptische Messung der spezifischen Bruchenergie während des Bruchvorgangs bei Plexiglas", Proceedings, Intern. Conf. Physics of Non-Crystalline Solids, Delft, The Netherlands, 1964, pp. 481-490.
3. Theocaris, P.S., "Local Yielding Around a Crack Tip in Plexiglas", J. Appl. Mech., Vol. 37, 1970, pp. 409-415.
4. Kalthoff, J.F., Beinert, J., and Winkler, S., "Measurements of Dynamic Stress Intensity Factors for Fast Running and Arresting Cracks in Double-Cantilever-Beam-Specimens", ASTM STP 627 - Fast Fracture and Crack Arrest, American Society for Testing and Materials, Philadelphia, U.S.A., 1977, pp. 161-176.
5. Kalthoff, J.F., Beinert, J., Winkler, S., and Klemm, W., "Experimental Analysis of Dynamic Effects in Different Crack Arrest Test Specimens", ASTM STP 711 - Crack Arrest Methodology and Applications, American Society for Testing and Materials, Philadelphia, U.S.A., 1980, pp. 109-127.
6. Kalthoff, J.F., Winkler, S., and Beinert, J., "The Influence of Dynamic Effects in Impact Testing", Int. J. Fracture, Vol. 13, 1977, p. 528.
7. Kalthoff, J.F., Böhme, W., Winkler, S., and Klemm, W., "Measurements of Dynamic Stress Intensity Factors in Impacted Bend Specimens", CSNI Specialist Meeting on Instrumented Precracked Charpy Testing, EPRI, Palo Alto, Calif., U.S.A., Dec. 1980.
8. Beinert, J. and Kalthoff, J.F., "Experimental Determination of Dynamic Stress Intensity Factors by Shadow Patterns", in Mechanics of Fracture, Vol. 7, ed. by G.C. Sih, Martinus Nijhoff Publ., The Hague, Boston, London, 1981, pp. 281-330.
9. Kalthoff, J.F., "Stress Intensity Factor Determination by Caustics", Proc. Int. Conf. Exper. Mech., Society for Experimental Stress Analysis and Japan Society of Mechanical Engineers, Hawaii, U.S.A., May 23 - 28, 1982.
10. Theocaris, P.S., "Complex Stress-Intensity Factors at Bifurcated Cracks", J. Mech. Phys. Solids, Vol. 20, 1972, pp. 265-279.
11. Seidelmann, U., "Anwendung des schattenoptischen Kaustikenverfahrens zur Bestimmung bruchmechanischer Kennwerte bei überlagerter Normal- und Scherbeanspruchung", Report No. 2/76 of the Institut für Festkörpermechanik, Freiburg, Germany, 1976.
12. Ireland, D.R. "Critical Review of Instrumented Impact Testing", Proc. Int. Conf. Dynamic Fracture Toughness, London, July 5 - 7, 1976.

13. Kalthoff, J.F., Winkler, S., Klemm, W., and Beinert, J., "On the Validity of K_{Ia} -Measurements in Instrumented Impact Tests", Trans. 5th Int. Conf. Structural Mechanics in Reactor Technology, G 4/5, Berlin Germany, Aug. 13 - 17, 1979.
14. ASTM E 24.03.03, "Proposed Standard Method of Tests for Instrumented Impact Testing of Precracked Charpy Specimens of Metallic Materials' Draft 2c, American Society for Testing and Materials, Philadelphia, 1980.
15. Herrmann, G., "Dynamic Fracture of Beams in Bending", Euromech Colloquium 91 Dynamic Crack Propagation in Solids, Polish Academy of Sciences, Warsaw-Jablonna, Poland, Aug. 17 - 20, 1977.
16. Theocaris, P.S. and Katsamanis, F., "Response of Cracks to Impact by Caustics", Eng. Frac. Mech., Vol. 10, 1978, pp. 197-210.
17. Kalthoff, J.F. and Shockey, D.A., "Instability of Cracks Under Impulse Loads", J. Appl. Phys., Vol. 48, 1977, pp. 986-993.

END

FILMED

1-84

DTIC