

Technical Report 579

12

HOW TO DEVELOP TASK SUMMARIES FOR SOLDIER'S MANUALS VOLUME II: DEVELOPER'S GUIDE

Elmo E. Miller and Lawrence E. Lyons
Human Resources Research Organization

ARI FIELD UNIT AT FORT HOOD, TEXAS

AD-A133-412

DTIC
ELECTE
DEC 5 1983
S B



U. S. Army

Research Institute for the Behavioral and Social Sciences

April 1982

Approved for public release; distribution unlimited.

83 12 05 076

DTIC FILE COPY

U. S. ARMY RESEARCH INSTITUTE FOR THE BEHAVIORAL AND SOCIAL SCIENCES

A Field Operating Agency under the Jurisdiction of the
Deputy Chief of Staff for Personnel

JOSEPH ZEIDNER
Technical Director

L. NEALE COSBY
Colonel, IN
Commander

Research accomplished under contract
for the Department of the Army

HUMAN RESOURCES RESEARCH ORGANIZATION

NOTICES

DISTRIBUTION: Primary distribution of this report has been made by ARI. Please address correspondence concerning distribution of reports to: U.S. Army Research Institute for the Behavioral and Social Sciences, ATTN: PERI-TST, 5001 Eisenhower Avenue, Alexandria, Virginia 22333.

FINAL DISPOSITION: This report may be destroyed when it is no longer needed. Please do not return it to the U.S. Army Research Institute for the Behavioral and Social Sciences.

NOTE: The findings in this report are not to be construed as an official Department of the Army position, unless so designated by other authorized documents.

Unclassified

SECURITY CLASSIFICATION OF THIS PAGE (When Data Entered)

REPORT DOCUMENTATION PAGE		READ INSTRUCTIONS BEFORE COMPLETING FORM
1. REPORT NUMBER Technical Report 579	2. GOVT ACCESSION NO.	3. RECIPIENT'S CATALOG NUMBER
4. TITLE (and Subtitle) HOW TO DEVELOP TASK SUMMARIES FOR SOLDIER'S MANUALS VOLUME II: DEVELOPER'S GUIDE		5. TYPE OF REPORT & PERIOD COVERED
		6. PERFORMING ORG. REPORT NUMBER FR-MTRD(TX)-81-9
7. AUTHOR(s) Elmo E. Miller and Lawrence E. Lyons		8. CONTRACT OR GRANT NUMBER(s) MDA903-C-79-0191
9. PERFORMING ORGANIZATION NAME AND ADDRESS Human Resources Research Organization 300 North Washington Street Alexandria, Virginia 22314		10. PROGRAM ELEMENT, PROJECT, TASK AREA & WORK UNIT NUMBERS 2Q262717A790
11. CONTROLLING OFFICE NAME AND ADDRESS US Army Research Institute for the Behavioral and Social Sciences, 5001 Eisenhower Avenue Alexandria, Virginia 22333		12. REPORT DATE April 1982
		13. NUMBER OF PAGES 118
14. MONITORING AGENCY NAME & ADDRESS (if different from Controlling Office) ARI Field Unit-Fort Hood HQ TCATA, PERI-SH Fort Hood, Texas 76544		15. SECURITY CLASS. (of this report) Unclassified
		15a. DECLASSIFICATION/DOWNGRADING SCHEDULE --
16. DISTRIBUTION STATEMENT (of this Report) Approved for public release; distribution unlimited.		
17. DISTRIBUTION STATEMENT (of the abstract entered in Block 20, if different from Report) -- --		
18. SUPPLEMENTARY NOTES Dr. Charles O. Nystrom was the contracting officer's representative.		
19. KEY WORDS (Continue on reverse side if necessary and identify by block number) Printed instructions Task taxonomy Instructional materials Writers' guide Skill performance aids Job aids Performance-oriented training Soldier's Manual Manuals Training		
20. ABSTRACT (Continue on reverse side if necessary and identify by block number) A method for improving printed instructions was developed and presented in a guidebook for writers of Soldier's Manuals. The research involved (A) revision of a wide variety of examples, (B) formulation of rules inherent in those revisions, (C) derivation of a taxonomy of tasks to make the method specifically applicable to each kind of task. The method involves increasing directness, particularly in relating text and illustrations, to sharply reduce the burden on short-term memory. It also involves giving sufficient information to specify (cont'd)		

Unclassified

SECURITY CLASSIFICATION OF THIS PAGE(When Data Entered)

cont 4
Block 20. (Continued)

each response, rather than relying upon vague assumptions about level of background. Effective revisions almost always involve many fewer words, fewer details, but greater specificity, than the original instructions; so one kind of instructions generally is best for novice and expert alike. A demonstration experiment involved instructions on filling out a standard maintenance form. The revision reduced errors in checking entries by 64%; the people indicated greater confidence when following the revised instructions, and found them much easier to understand ($p < .01$, each result).

Technical Report 579

**HOW TO DEVELOP TASK SUMMARIES FOR
SOLDIER'S MANUALS
VOLUME II: DEVELOPER'S GUIDE**

Elmo E. Miller and Lawrence E. Lyons
Human Resources Research Organization

Submitted by:
George M. Gividen, Chief
ARI FIELD UNIT AT FORT HOOD, TEXAS

Approved by:
Edgar M. Johnson, Director
SYSTEMS RESEARCH LABORATORY

**U.S. ARMY RESEARCH INSTITUTE FOR THE BEHAVIORAL AND SOCIAL SCIENCES
5001 Eisenhower Avenue, Alexandria, Virginia 22333**

**Office, Deputy Chief of Staff for Personnel
Department of the Army**

April 1982

**Army Project Number
2Q262717A790**

Human Performance Effectiveness and Simulation

Approved for public release; distribution unlimited.

ARI Research Reports and Technical Reports are intended for sponsors of R&D tasks and for other research and military agencies. Any findings ready for implementation at the time of publication are presented in the last part of the Brief. Upon completion of a major phase of the task, formal recommendations for official action normally are conveyed to appropriate military agencies by briefing or Disposition Form.

FOREWORD

The Fort Hood Field Unit of the US Army Research Institute for the Behavioral and Social Sciences (ARI) provides support to Headquarters, TCATA (TRADOC Combined Arms Test Activity) and to III Corps. The support for III Corps involves investigation of training and other human factors problems that are common to FORSCOM units, including individual training.

The modern Army requires large numbers of soldiers to know how to perform a wide variety of tasks. Soldier's Manuals are the basic written instructions on how to do the important tasks for each job.

This report describes a system for developing task performance instructions (TPI) for Soldier's Manuals. Volume I is a report of some related studies, of the method used in developing the system, and a demonstration experiment that was conducted. Volume II is a developer's guide to be used in implementing the system.

The TPI system provides principles for revising the basic structure of instructions to meet particular needs of soldiers. This approach differs from many previous studies, which tended to focus attention on details of wording. One unusual technique is integrating wording and illustrations to specify responses. Another innovation is to cluster instructions so that they apply to specific responses. The approach also involves classification of tasks, so that relatively specific guidance can be given to developers.

ARI research in this area is conducted as an inhouse effort, and as joint efforts with organizations possessing unique capabilities for human factors research. The research described in this report was done by personnel of the Human Resources Research Organization (HumRRO), under Contract No. MDA903-79-C-0191, monitored by Dr. Charles O. Nystrom from the ARI Fort Hood Field Unit. This research is responsive to the objectives of RDTE Project 2Q262717A790, "Human Factors and Training Research in Military Organizations and Systems," FY 1980 Work Program.

Credit and appreciation is due Dr. Robert G. Cooper, who conducted the demonstration experiment reported in Volume I.

JOSEPH ZEIDNER
Technical Director



Accession For	
NTIS GRA&I	<input checked="" type="checkbox"/>
DTIC TAB	<input type="checkbox"/>
Unannounced	<input type="checkbox"/>
Justification	
By	
Distribution/	
Availability Codes	
Dist	Avail and/or Special
A-1	

**HOW TO DEVELOP TASK SUMMARIES FOR SOLDIER'S MANUALS VOLUME II:
DEVELOPER'S GUIDE**

BRIEF

Requirement:

Soldier's Manuals (SM) are the basic written instructions for performance of critical tasks in most Army jobs. SM are intended as a sufficient ("one-stop") learning guide for those tasks, and are a key element of the Enlisted Personnel Management System (EPMS). Since they first appeared in 1976, SM have demonstrated great promise, but various kinds of problems have also become apparent, as might be expected in so vast a system.

The major research objective is a system for improving task performance instructions (TPI) in SM. A related objective is a developer's guide for implementing that system.

Procedure:

Several task summaries from current SM were revised to serve as examples, and to provide an empirical basis for the principles of revision. The method involves basic restructuring of TPI to meet the needs of the soldier. A classification of tasks was developed so that guidance for developers is relatively specific.

Principal Findings:

- Instructions in SM could be much briefer and more effective.
- TPI may be improved substantially by techniques using illustrations to specify action.
- Different instructional strategies are needed for different kinds of tasks.
- Task performance and reader confidence are improved significantly when instructions are revised by the TPI system.

Utilization of Findings:

Soldier's Manuals may be improved by following the Developer's Guide, which is Volume II of this report.

CONTENTS

VOLUME II: DEVELOPER'S GUIDE

CHAPTER	PAGE
1 Introduction	1-1
Future Soldier's Manuals	1-1
Preview	1-2
2 Characteristics of Effective Task Summaries	2-1
Extreme Brevity	2-1
Illustrations	2-1
Focus on Results	2-10
Configuration	2-10
Focus of Attention, Continuity	2-10
Relatedness	2-10
Amount of Detail	2-10
Viewpoint	2-11
Specifying Responses	2-11
Organization	2-12
Numbered Steps	2-12
Sequence	2-12
Specificity	2-12
Language	2-13
Alternate Circumstances	2-13
Specifying Objectives	2-13
References and Page Numbers	2-14
3 Drafting a Task Summary	3-1
Starting Conditions	3-1
Input Phase	3-1
Task Analysis (For Procedural Tasks)	3-3
Task Structure Diagram	3-3
Selection of Major Steps	3-9
Writing and Illustrating Each Step	3-9
Statement of Objectives	3-12
Written Techniques	3-12
Basic Task Logic	3-15
Examples and Illustrations	3-15
Other Practices	3-16
Laying Out Text and Illustrations	3-17

4 Different Kinds of Tasks	4-1
Section 1: Classification of Tasks	4-1
Major Kinds	4-1
Criterion-driven Performance (i.e., "soft skills")	4-1
Strength and Coordination	4-1
Component Skills	4-3
Procedures With Data	4-4
Procedures With Equipment	4-4
Subdivision of Task Categories	4-4
Section 2: Procedures With Equipment	4-5
Construction	4-5
Machine Operations	4-7
Setup	4-7
Operate	4-9
Field Operations	4-11
Comparison With Machine Operations	4-11
Comparison With Construction, Assembly	4-11
Approach	4-12
An Example	4-12
Related to Other Kinds of Tasks	4-14
Maintenance	4-15
Preventive Maintenance	4-15
Corrective Maintenance	4-19
Section 3: Procedures With Data	4-22
Salient Characteristics	4-22
Graphics	4-23
Read Plot	4-23
Draw Plot	4-23
Composition	4-23
Make Simple Entries	4-24
Follow Format	4-32
Plan	4-39
Calculation	4-40
Calculation Using "Display"	4-40
Calculation Without Display	4-40
Using ADP Systems	4-40
Chaos The Norm	4-42
Insuring Coverage	4-43
Section 4: Component Skills	4-45
Identification	4-46
Identification of Equipment	4-46
Concept Formation	4-46
Decision-Making	4-46

Communication	4-51
Voice Communications	4-51
Use Hand Signals, or Mechanical Signs	4-51
Use Job Aids	4-58
Section 5: Criterion-Driven Performance	4-60
Supervisory Tasks	4-60
Prepare and Conduct Performance-Oriented Training	4-60
Future Research Needed	4-61
5 Tryout and Review	5-1
Review	5-1
Simplification	5-1
Relevance	5-1
Directness	5-1
Sufficiency	5-2
Notes	5-2
Trainer's Notes	5-4
Feedback	5-5
Effectiveness	5-5
Accuracy	5-6
Acceptability	5-6
6 Notes For Trainers	6-1
Practice Conditions	6-1
Pictorial Simulation Appropriate	6-1
Equipment Required For All Practice	6-1
Functions of the Trainer	6-2
Instructions For Task Performance	6-2
Practice/Testing	6-2
Administration of Training	6-2
Printed Criteria For Unit Exercises	6-2
APPENDIX A: Table A-1. Classification of Tasks	A-1

FIGURES

Fig. 1-1	Branching schema for this manual.	1-3
Fig. 3-1	Information system for developing task instructions.	3-2
Fig. 3-2	Task structure diagram.	3-4
Fig. 3-3	Task structure diagram (incomplete) showing a different kind of branching.	3-9
Fig. 3-4	Determination of major steps (numbered)	3-10
Fig. 4-1	Flow chart for classifying a task.	4-2
Fig. 4-2	Specifying standards characteristics for a "construction" task.	4-6
Fig. 4-3	Product specification in a mechanical assembly.	4-6

Fig. 4-4	Illustration of a construction with vague characteristics.	4-7
Fig. 4-5	Original instructions on testing during assembly.	4-8
Fig. 4-6	Revision, which integrates text and illustrations	4-8
Fig. 4-7	Sight picture showing alinement.	4-10
Fig. 4-8	Burst-on target (BOT).	4-10
Fig. 4-9	Illustrating a "positioning" response.	4-12
Fig. 4-10	Difficult discrimination.	4-12
Fig. 4-11	"Picture-guide" technique in disassembly.	4-17
Fig. 4-12	Example of job performance aid format.	4-18
Fig. 4-13	Measuring voltage, 12 volt battery.	4-21
Fig. 4-14	Calculation using a data display.	4-41
Fig. 4-15	Analogical illustration to show the functions of DISPLAY CONTROL panel.	4-44
Fig. 4-16	Comparative illustrations showing proper technique.	4-47
Fig. 4-17	Correspondence of codes.	4-56
Fig. 4-18	Revision of example, avoiding "left-right" confusion.	4-56
Fig. 4-19	Signals, meaning.	4-57
Fig. 5-1	Subroutine for setting deflection on mortar.	5-3

Chapter 1

INTRODUCTION

The purpose of this manual is to describe a method for developing task summaries for Soldier's Manuals (SM). It is intended primarily for you who will develop those instructions. Secondly, it is for other people who are involved in developing the manuals, including those who determine policy, supervisors and administrators, and specialists in research and development.

Another document describes the influences that led to production of this manual, the method of its development, and some of the research evidence that relates to the recommended practices. Hopefully, this manual will become the basic written guide for task summaries. That would be a document to implement a TRADOC Regulation covering Soldier's Manuals and Job Books, which is now being drafted.

FUTURE SOLDIER'S MANUALS

Soldier's Manuals will be somewhat different, if this manual accomplishes its purpose. The current objectives would be pursued, but more effectively. Certain functions would be added, particularly for trainers.

1. Sufficient, but brief. The new task summaries will still be sufficient to enable a soldier to perform the task without other references, except for those manuals that are normally used on the job. But they should be briefer, usually about half the length of the original version. And they should be much easier to read and apply. To do that, task summaries will be more thoroughly performance-oriented, rather than topic-oriented. In other words, they will be designed for action.

Designing the action involves three criteria for evaluating the information in instructions: (1) relevance, (2) directness, and (3) sufficiency. Relevance is a matter of including only information the soldier needs for task performance. Directness is a matter of finding ways to sharply reduce the number of steps that you require of the soldier in following your instructions. In other words, you provide shortcuts. One way of doing that is to sort the information so that it appears in the sequence that it is needed, and is clustered to allow the soldier to see what information applies to each action. Sufficiency is a matter of providing all the information the soldier needs for task performance, in a form he can use.

One way to apply these criteria is by using illustrations for action. That means that we depend upon illustrations to carry the instructional message, rather than adding them as an afterthought, as adjuncts. You determine which will work better under the circumstances, illustrations or text, and use it.

2. Notes for trainers. A Soldier's Manual will include various sections for trainers. The term "trainer" includes everyone involved in the conduct and management of training, from the soldier's immediate supervisor to the battalion commander. These sections replace the old "Commander's Manual" series. The new term "trainer" is used instead of "commander" to avoid the implication that only high level management is involved.

A section near the beginning of each level 1 manual will give general information for trainers. It will include a description of the Enlisted Personnel Management System (EPMS), particularly the function of the Soldier's Manual in that system. There will be more specific sections of "notes for trainers" at the beginning of various sections, as they apply to groups of tasks. Occasionally there may be "trainer's notes" that are specific to a particular task. The more specific kinds of notes for trainers will be generated primarily in response to the needs that you identify during development of task summaries.

3. Performance testing. Soldier's Manuals have been designed to prepare soldiers for Skill Qualification Testing (SQT), and the new manuals will refine the techniques for performing that function. The new manuals will also have several features to provide for diagnostic testing; that is, testing during training, to determine precisely what a soldier needs in preparation for SQT. Diagnostic testing may be conducted by a trainer or by another soldier. If a novice soldier is to use your task summary for checking performance of another soldier, it must be simple indeed.

PREVIEW

The method for developing task summaries will be described as a procedure, to the extent that it can be at present. Wherever we have not yet reduced the method to a procedure, we shall specify some criteria or rules for task instructions, which you may apply to determine needed revisions.

In order to clarify the goal, we begin Chapter 2 with an example of a task summary that was revised by our method, and some rules involved in the revision. The rest of the manual is a step-by-step guide for applying our method, as diagrammed in Figure 1-1. This shows the schema that will allow you to focus on the kind of task summary you're developing, and skip the discussion on other kinds of tasks. This means you only have to read about half the manual, and much of this is examples. Wherever there is a choice point in this manual, you will see a boxed-off paragraph called "Branching Instructions."

The first branching comes after discussion of the general approach (Chapter 3, section 1) because the method of tasks analysis discussed in section 2 applies only to procedures. In Chapter 4, section 1, different kinds of tasks are distinguished. Sections 2-5 are specific suggestions for each kind of task summary. Within each of these sections you only need to read about the particular kind you are involved with. Methods for tryouts and revisions are discussed in Chapter 5. Use of the SM by trainers is discussed in Chapter 6, especially as it relates to the kind of manual you develop.

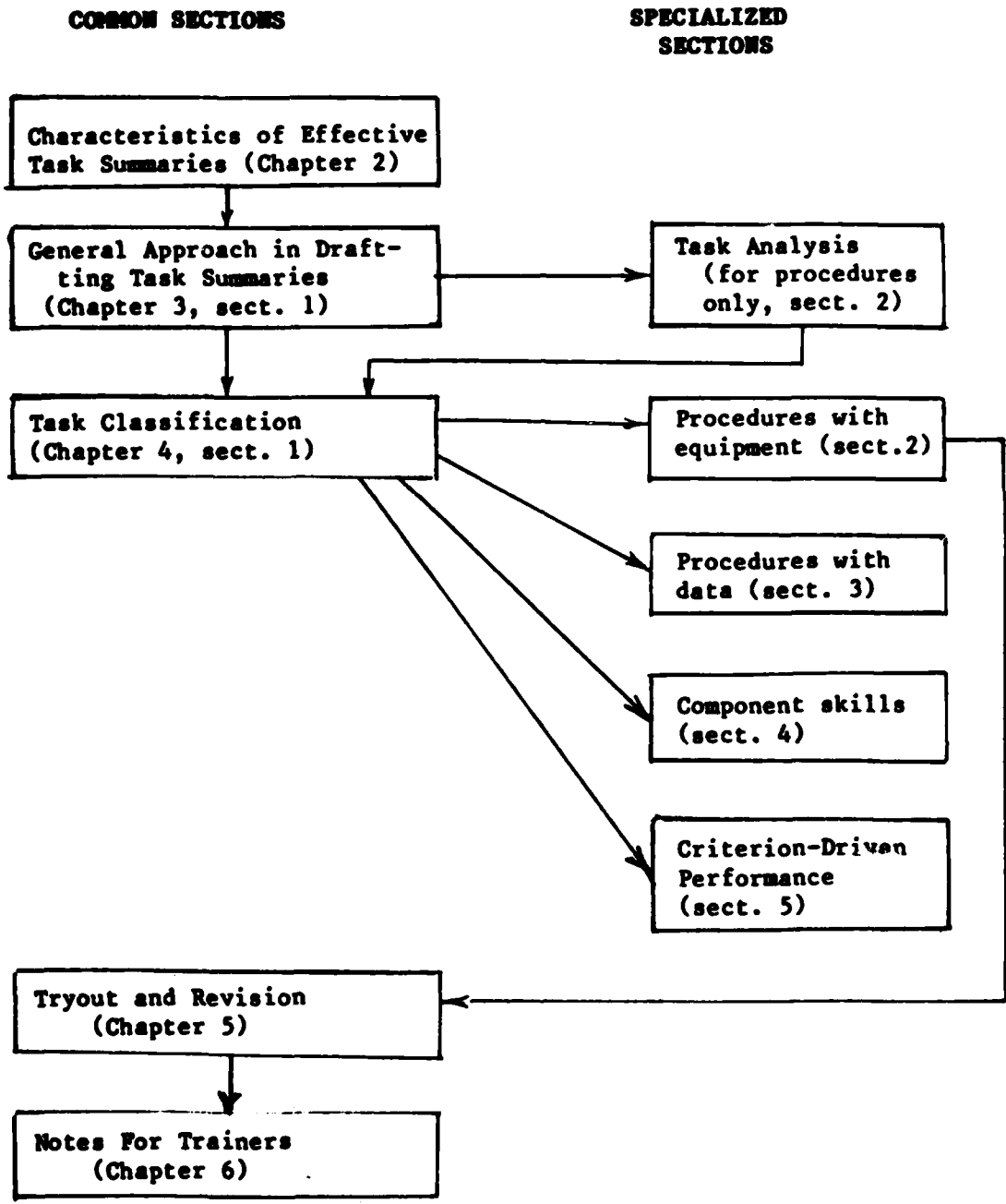

Figure 1-1. Branching schema for this manual.

Chapter 2

CHARACTERISTICS OF EFFECTIVE TASK SUMMARIES

This chapter is to show what an effective task summary looks like, and to specify the characteristics that distinguish it from ineffective ones. This is to give you a clear view of the goal. When you finish reading this chapter, you should be able to recognize deficiencies in existing task summaries and to describe the kinds of revision that are needed. In Chapter 3 we will describe a procedure for making such revisions.

Consider the instructions in "Place a Ground-Mounted 81-mm Mortar Into Action" on the following pages, taken from the current Soldier's Manual. Then read our revision on the following pages. This is a fairly typical procedure with equipment, which is the most common basic kind of task. Therefore, any rules that we derive will apply broadly. We underline the rules so that you can readily apply them to any revision anytime.

EXTREME BREVITY

Notice that the revision is much briefer, and much easier to read. The original took six pages, and the revision two pages. There is an even greater reduction in number of words. Reduce any task summary to the barest essential in both words and illustrations. Most task summaries can be reduced to half of their original length or less.

There is a common misconception that most confusions result from insufficient detail. Actually, the problem is more likely to be too much detail, along with vague, strung out, disconnected writing. Writers seem to find all sorts of reasons for adding all sorts of things, but none for discarding anything. The harder they try to be clear, the worse it gets.

Be bold in reducing task summaries, because there is no "safe" way of including extra junk. Say only what is really needed, and no more. The criteria for what is essential are given below. And don't worry about leaving out something critical, because you are going to try out your task summaries before publication; rest assured that you will find out whether your instructions are sufficient when a novice reads them.

ILLUSTRATIONS

The most pervasive problem with illustrations in Soldier's Manuals (SM) is that they mimic the examples seen in other technical materials, which usually are designed for understanding (i.e., what a system is, or how it works). That is quite different from the purpose of SM, which is to show the soldier what to do, specifically. Usually the soldiers understand the system quite well enough for practical purposes even without instruction, but they need to know specifically what they should do. Sometimes illustrations for understanding are desirable, or even necessary. But illustrations for performance are your essential tools, your "bread and butter."

TASK NUMBER: 071-321-3901

**PLACE A GROUND-MOUNTED 81-MM
MORTAR INTO ACTION**

CONDITIONS:

You are the gunner on an 81-mm mortar. Given an 81-mm mortar complete with sight (either M53 or M34A2), baseplate, and direction stakes, and two personnel to act as assistant gunner and ammunition bearer. Each member of the mortar crew will perform this task acting as the gunner.

STANDARDS:

The mortar will be mounted within 90 seconds IAW the performance measures below.

PERFORMANCE MEASURES:

To ground-mount the 81-mm mortar:

1. Baseplate stake and the direction stake will be in place, 25 meters apart (figure 1).

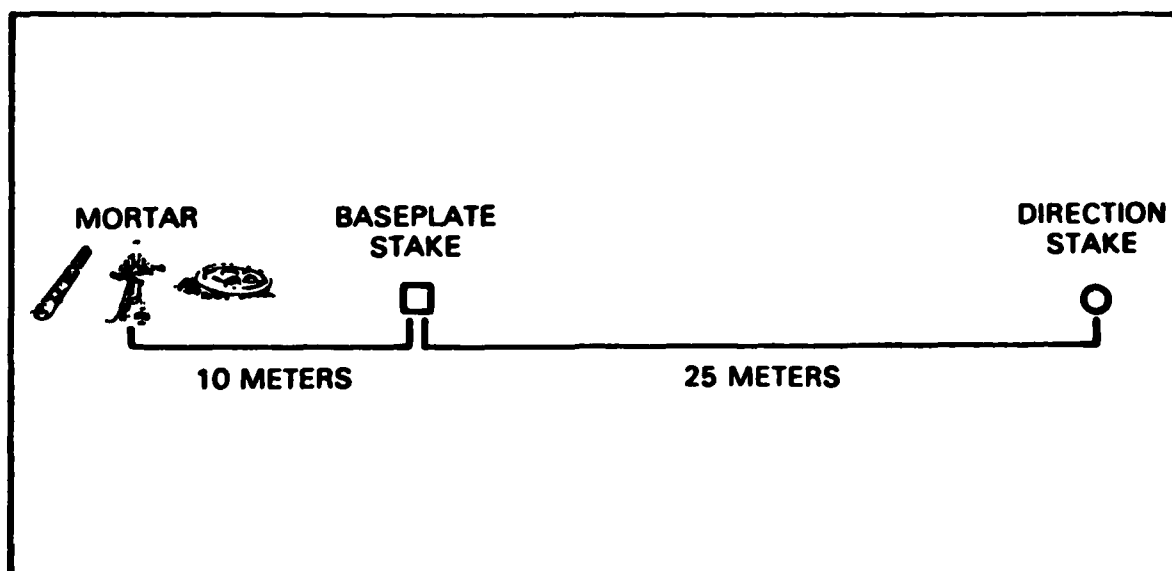

Figure 1.

2-VIII-A-1.1

c. At the baseplate stake, the following actions will take place:

(1) The ammo bearer will place the front edge of the baseplate against the stake, align the left edge of the cutout portion with the baseplate stake (figure 7), and move out of the way.

(2) The gunner will move around and to the front and face the baseplate (figure 8).

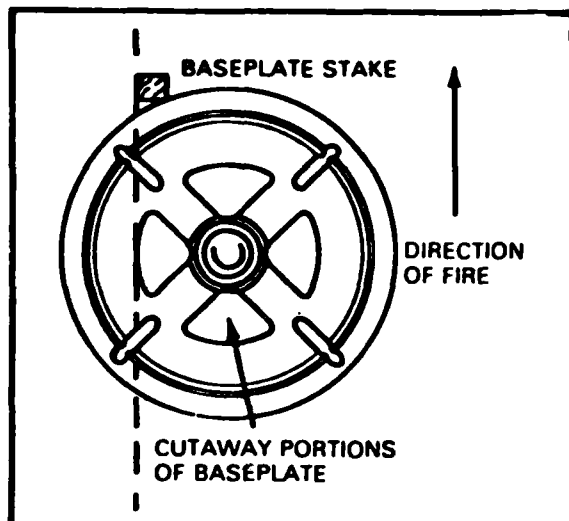

Figure 7.



Figure 8.

(a) He places the bipod about 2 feet in front of the baseplate, aligned with the right edge of the baseplate.

(b) Kneeling on his right knee in front of the bipod and supporting it by holding the gear case with his left hand, he unhooks the chain, unwinds it, and rehooks the end loop on the chain hook.

(c) He lifts the left leg and opens the legs to the full extent of the doubled chain.

(d) He centers the guide tube and locks the locking nuts (figure 8).

(e) The gunner then moves to the left side of the bipod while supporting the bipod with his left hand on the shock absorber, pulls out the clevis locking pin, and raises the yoke assembly to the horizontal position (figure 9).

(f) The assistant gunner inserts the barrel (mounts attachment ring lug up) into the yoke assembly until the lug fits into the shock absorber clevis (figure 9).

(g) The gunner then inserts the clevis locking pin (figure 9).

2-VIII-A-1.4

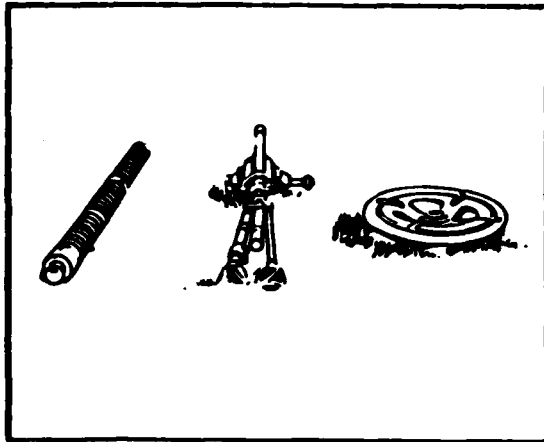

Figure 2.



Figure 3.

2. Bipod, barrel, and baseplate will be laid out (as shown in figure 2) 10 meters to the rear of the baseplate stake (figure 1).

3. The sight, in its locked case, will be placed 2 feet to the left and 2 feet in front of the baseplate stake (the gunner has the option of placing the sightcase anywhere he wants it in relation to the baseplate stake) (figure 3).

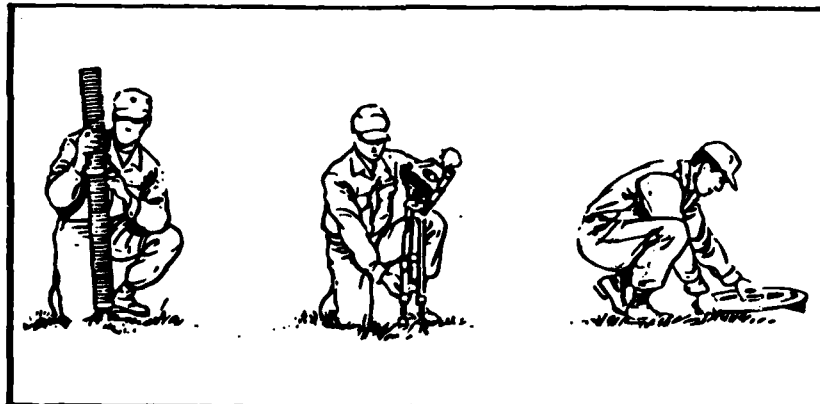

Figure 4.

4. At the command "MAKE A PREMOUNT CHECK," the crew members will make the following checks (figure 4):

a. Gunner: The gunner will make the following checks on the bipod.

(1) The spread chain is doubled, wrapped around the legs, and hooked to the left leg.

(2) There is a two-finger clearance above the adjusting nut on the left leg.

(3) The locking nut is neither too loose nor too tight.

2-VIII-A-1.2

(4) The traversing bearing is centered.

(5) The clevis locking pin is fully seated and not binding.

b. Assistant Gunner: The assistant gunner makes the following checks on the barrel:

(1) Mount attachment ring is centered between the white lines on the barrel.

(2) Barrel is clean inside and outside.

(3) Firing pin is visible.

(4) The spherical projection is clean and the firing pin is firmly seated.

c. Ammo Bearer: The ammo bearer makes the following checks on the baseplate:

(1) The rotatable socket cap moves freely.

(2) Baseplate has no cracks.

d. As each member of the crew checks his piece of equipment, he will notify the gunner that it is "OK," or what is wrong with it. When the gunner is satisfied that all is ready, he will announce to the squad leader "ALL CORRECT." The crew is now ready to mount the mortar.

5. Perform the following actions upon the squad leader's command "TO YOUR FRONT, ACTION."

a. At the command "TO YOUR FRONT," all crew members will secure their piece of equipment from the ground (figure 5).

b. At the command "ACTION," the crew members will move rapidly to the baseplate stake (figure 6).

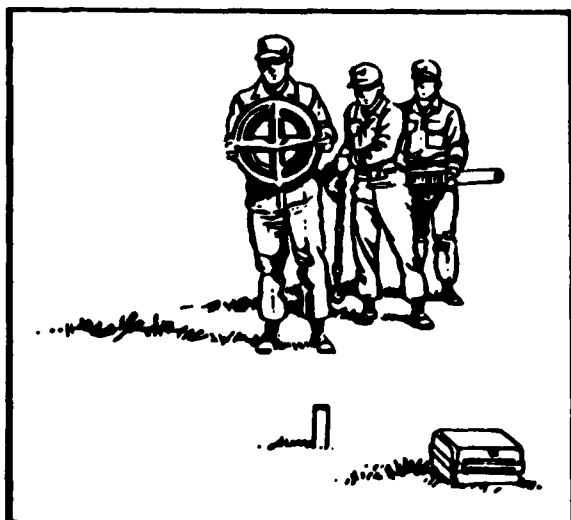

Figure 5.

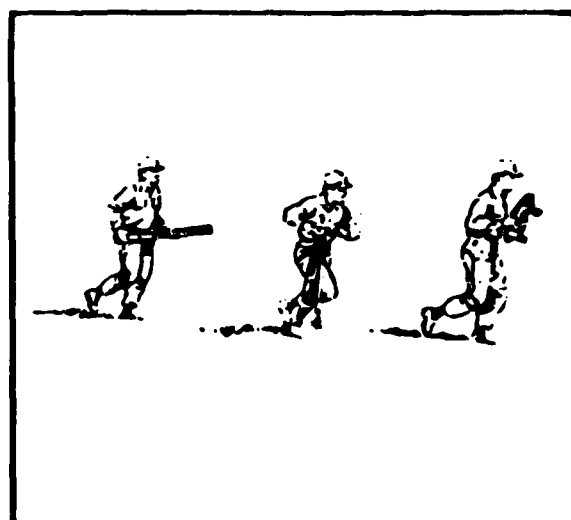

Figure 6.

2-VIII-A-1.3

(h) The assistant gunner then lowers the rear of the barrel, inserts the spherical projection into the baseplate socket, and locks the barrel to the base by turning the barrel 90 degrees (1/4 turn).

(i) The gunner takes the sight out of the sightbox and inserts it into the dovetail slot on the yoke assembly and sets the mounting data on the sight:

1. M53 Sight.

- a. Deflection 3200
- b. Elevation 1100

2. M34A2 Sight.

- a. Deflection 0
- b. Elevation 1100

(j) With the help of the assistant gunner, he shifts the bipod (if needed) and lays on the directional stake with the correct sight picture (figures 10 and 11) and ALL bubbles level.



Figure 9.

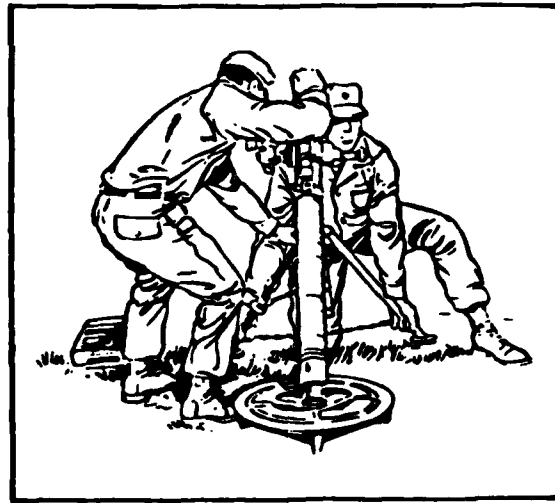

Figure 10.

2-VIII-A-1.5

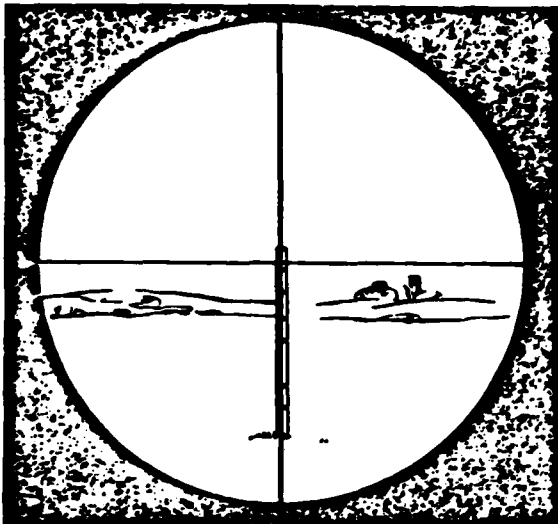

Figure 11.

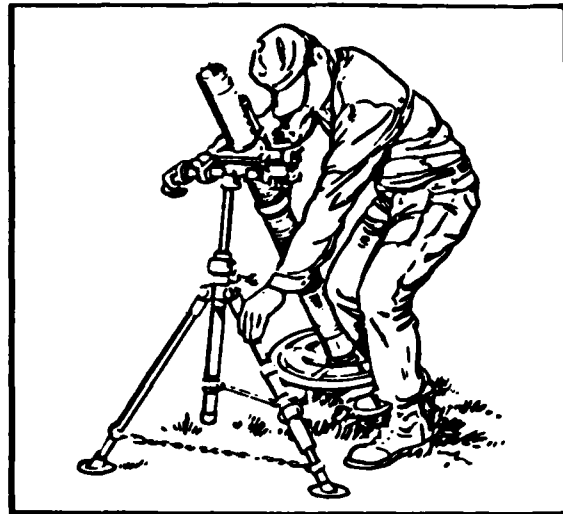

Figure 12.

(k) After making fine adjustments, the gunner steps away from the mortar and announces "UP" (figure 12).

(l) The mortar is now mounted.

6. The squad leader checks the mortar for the following:

- a. Correct sight settings for deflection and elevation (no tolerance).
- b. Bubbles on sight are level (within outer red lines).
- c. Vertical crossline is no more than two mils off the left edge of the directional stake.
- d. Traversing bearing is no more than two turns to the left or right of center.
- e. Barrel is locked to baseplate.
- f. Baseplate is positioned correctly in relation to baseplate stake.

NOTE: The procedure for placement of the baseplate is the same in training or in combat except, in combat, the squad leader indicates where the mortar is to be mounted by placing the sightcase where he wants the mortar mounted. He then points in the direction the mortar is to be mounted. The baseplate is set close to the sightcase in the same manner as with the baseplate stake.

REFERENCE:

FM 23-90, 81-mm Mortar, C1, Feb 72 (page 61, para 74; page 88, para 103d)

2-VIII-A-1.6

GROUND-MOUNT 81-MM MORTAR

Conditions: You are the gunner in this situation.

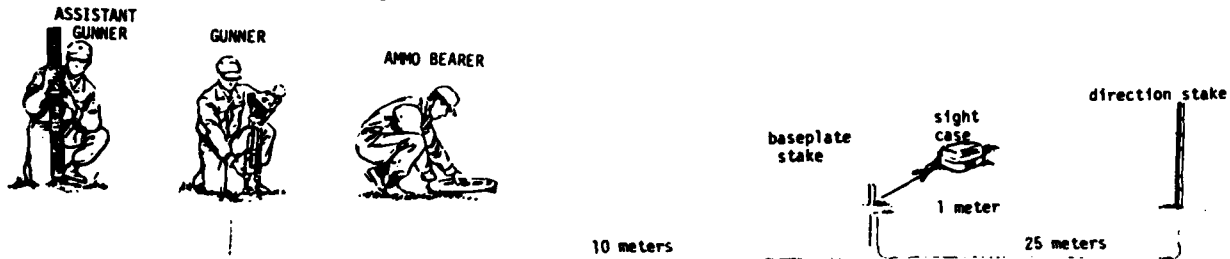

Standard: As the task is performed, the scorer will check to see that all points marked "o" are done. Later, on the mounted mortar, he will check all points marked "•".

Procedure:

1. Premount Check

Squad leader: "MAKE A PREMOUNT CHECK."

- a. Gunner. Check to see that spread chain is doubled, wrapped around the legs, and hooked to the left leg. The adjusting nut on the left leg should have a two-finger clearance and the locking nut should be just snug. The traverse bearing should be centered, and the clevis locking pin fully seated but not binding.
- b. Assistant gunner. Checks that the mount attachment ring is centered between two white lines. Barrel and spherical projection are clean. Firing pin is visible and firmly seated.
- c. Ammo bearer. Checks that the socket cap rotates freely. Baseplate has no cracks.

Each says "OK." Then you say "ALL CORRECT."

2. Assembling Mortar

Squad leader: "TO YOUR FRONT." (crew stands up) "ACTION."

Scorer starts timing, 90 seconds.

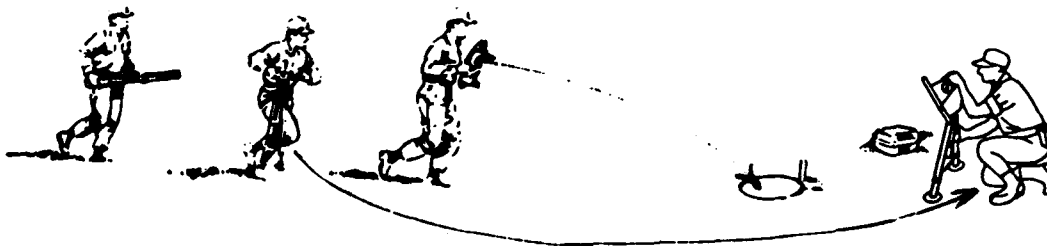

°hook chain and spread bipod legs

°center the guide tube and lock the nut

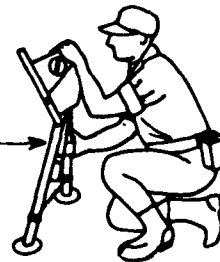

Then pull out clevis locking pin and raise the yoke assembly so that assistant gunner can slide barrel into it.

- °Insert clevis locking pin and be sure it is fully seated

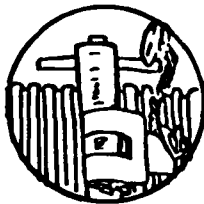

3. Mounting sight, adjusting

- °Remove sight from case and mount it. Be sure it is fully seated.
- °Turn deflection to 3200 mils* and elevation to 1100 mils.



direction stake

4. Alinement

- Aline mortar with direction stake by shifting bipod legs.
- °Level and adjust traverse to aline with direction stake.

- °left edge of direction stake (+ 2 mils)

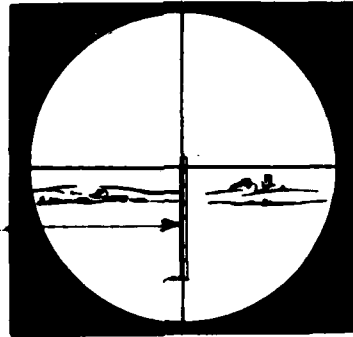

Gunner: Say "UP."

5. Check by Scorer

- °done in 90 seconds
- °guide tube centered, locking nut locked
- °clevis pin fully seated
- °sight fully seated
- °deflection 3200 mils*, elevation 1100 mils
- °both level bubbles within red lines
- °traverse within two turns of center
- °sighted on left edge of direction stake, within 2 mils.

*These directions assume the M53 sight. If you should have an M34A2 sight, the deflection is set at 0 mils, instead of 3200 mils.

Focus on Results

In order to determine what information the soldier really needs, first think of the conditions at the start and the results he must achieve. Then list a few intermediate objectives. These form the skeleton for both illustrations and organization of the text, as discussed below. Put off consideration of body movements and manipulation of parts. If any such details are critical for results, you will discover that later.

Configuration

Use illustrations to show the configuration of men and equipment at significant stages of task performance. Significant stages are the initial conditions, the final results, and some intermediate objectives, whenever these stages are not obvious. An example of a "configuration" illustration is the first one in the revision of the mortar example. This combines several illustrations from the original task summary. The illustrations in the original had a disconnected quality, because the developer concentrated on details, sacrificing the "big picture" and consistency of viewpoint. Whenever a task involves several people and things, they should all be shown together in one illustration at the start. Labels should be provided for those people and things that are not recognizable, but only those. (In the mortar example, the people needed labels because the drawing showed only three indistinguishable people in uniform.)

Focus of Attention, Continuity

Successive pictures should shift to show location of the action. A "blowup" may provide greater detail when needed, connected to the larger drawings to show its orientation, e.g., the "clevis locking pin." This blowup and the sight picture at the end show focus of attention. These two illustrations serve only that function.

There should be no abrupt changes in viewpoint (or camera angle) between successive pictures unless that change is indicated (e.g., by lines or by an explicit notation). An abrupt change in viewpoint is one that changes the ordinal positions of the elements pictured. An abrupt change is especially confusing if there are no cues to distinguish left from right, as with small objects.

Relatedness

The main purpose of a configuration illustration is to show the relations of all significant task elements with each other. When the elements are pictured in separate illustrations, this relatedness is destroyed. This is why one configuration illustration is so much clearer than the several pictures it replaces.

Amount of Detail

The elements in a configuration illustration can be small, because the soldier needs only enough detail to recognize the items. The illustrations showing focus of attention should include somewhat more detail. There is rarely any need for highly detailed

illustrations of procedures with equipment. The rare exceptions are tasks that require subtle stimulus discrimination (e.g., symptoms of immersion foot, compared with frost-bite).

Viewpoint

A "subjective" viewpoint is generally desirable for illustrations (i.e., as seen by the person performing the task), especially for focus of attention. However, the subjective viewpoint is often impossible with a configuration illustration if there is more than one person involved, because the "subject" is one of the people pictured. In such cases, it is not critical anyway.

Specifying Responses

Specify required responses in notes connected directly to the pictures, or with arrows printed over the picture. Do not duplicate these instructions in the text. This is quite different from the standard practice of using illustrations as a redundant kind of adjunct. You may have noticed that most manuals describe each action completely before referring to the figure. This implies that the reader is supposed to comprehend the text alone, and then look at the figure for confirmation, rather than using it to visualize the action as he reads.

When a response is specified in a note beside an illustration showing configuration, the note should be connected by a "call out" line to a particular location, which is the focus of attention. If the response is a familiar one (e.g., "hook chain"), that is sufficient. But if the response is unusual or hard to describe in words, use a separate blowup illustration showing only the focus of attention. When a response involves repositioning some element shown in the picture, this may be indicated by an arrow. A "ghost" view may be used with the arrow to show terminal position, especially when the movement is complex or unfamiliar. For example, in the revised mortar instructions, the second illustration used arrows and "ghosts" to show the gunner moving into position, and to show where the baseplate goes. These arrows and ghosts replaced lots of difficult sentences from the original task summary. Sometimes such arrows may be used with action words (e.g., "push").

Do not use two separate illustrations to show one response as "before and after" views. This is less effective than the "arrow and ghost" technique because it involves comparing pictures to detect small differences. However, you may use comparative illustrations as "right vs. wrong" view, to show technique. Then the "good" and "bad" views should be clearly labeled so that the soldier can sort them out mentally as he views them, rather than later. This is important for proper "filing" in his long-term memory.

Illustrations specifying action should generally be integrated with text, without using figure numbers. This saves the reader many steps, in addition to those saved by combining pictures. This kind of illustration is usually specific to a particular step in a procedure. Figure numbers should be reserved for those cases where there is a need for remote reference.

ORGANIZATION

Task summaries should be organized hierarchically, with major divisions and subdivisions, so that they can be understood and remembered. These divisions reflect the goals and subgoals of the task. Long, undifferentiated lists of steps should be avoided because they are very difficult to remember. They are even difficult to follow in a job aid, if there is any way for the soldier to "forget where he left off."

Numbered Steps

The numbered steps should be major divisions, specifying final result and intermediate objectives. For instance, the steps in the mortar example were: (1) premount check, (2) assembling mortar, (3) mounting the sight, adjusting, (4) alinement, and (5) check by scorer. The ideal is four to six numbered steps, and there should never be more than ten. If there are too many steps, combine some closely related ones. There always seems to be a way to do this, using common-sense concepts.

Progressive differentiation. Each numbered step should be subdivided, using two to four divisions at each level of the hierarchy. We will call this "progressive differentiation" because the reader first considers the most inclusive categories, subdividing them in several stages into particular responses. This approach is also called "chunking" or a "top down" approach. It is based upon the limitations of short-term memory.

Avoiding needless detail. In specifying each response, do not try to describe all details. Instead, try to think in terms of results, and don't mention any more details than necessary. In the mortar example, the revision said "hook chain" instead of this: "Kneeling on his right knee in front of the bipod and supporting it by holding the gear case with his left hand, he unhooks the chain, unwinds it, and rehooks the end hook on the chain hook." The result is a hooked chain, and that is all the soldier has to remember.

Combining small steps in sentences. Each instruction should combine two or three closely related actions in a sentence (e.g., "hook chain and spread bipod legs"). Combining steps at the lowest level is a handy means of mental grouping. But listing each small action separately gives an impression of disintegration. Relatively unimportant actions (i.e., those not scored) should be clustered in even more inclusive steps (e.g., the premount check for each crewmember).

Sequence

All events should be described in sequence, regardless of who does them. This may seem too obvious to mention, but it is often violated. Even mental steps should be given in sequence. For instance, the revision said "Scorer starts timing, 90 seconds" because the scorer must think "90 seconds" as he starts his stopwatch.

SPECIFICITY

Describe each response in specific terms because it is very hard for readers to think in generalities. "Specificity" is quite different from "amount of detail," although the two are often confused. For instance, "hook chain" is a highly specific instruction, which one can readily visualize, but it is not detailed.

Language

The most important performer (e.g., gunner) should be addressed directly, using second person. Other participants should be specified by role, in the third person, to avoid confusion (e.g., "Scorer checks...").

Spoken statements should be given literally, all capitals. Shortcuts are often taken, such as "gunner repeats command," even when these do not save words.

Titles for sections should not be stated as commands (second person). Instead, use the gerund form (e.g., "assembling mortar" rather than "assemble mortar") or the noun form (e.g., "premount checks" rather than "conduct the premount checks"). The reason is to distinguish organization from action. Otherwise, the reader is apt to be confused about when to act, because each response is commanded twice; one in general terms, and again in specifics.

Alternate Circumstances

In the revision, the directions were given for the M53 sight, with a footnote to cover the M34A2, which is obsolescent. Where there are variations in equipment or procedures, describe one specific performance while indicating the variation that is possible. In the case of the obsolescent sight, it is rather easy to make adjustments throughout the procedure by adding 3200 mils. There is no reason to require the reader to mentally juggle alternate cases presented in parallel fashion throughout the instructions.

Another mortar procedure told the soldier to "TRAVERSE RIGHT (LEFT)" and then kept giving each instruction two ways. That is very hard to understand, because it is hard to remember which way is under consideration. Do not use the parenthesis form for alternate circumstances or procedures. Instead, describe only one way in the text, and give the conversion formula in a footnote in common-sense terms (e.g., "If the original command is 'LEFT' then all subsequent commands will be reversed").

Specifying Objectives

Task title and numbering. Task title should be brief and direct (e.g., "ground-mount 81-mm mortar" instead of "place a ground-mounted 81-mm mortar into action"). Do not number the titles in the task summaries because the soldier has no need for them, and they are more likely to be confusing than helpful. The task numbers have become terribly complex, and are difficult to use for references. But trainers and developers may need the task numbers, so list them in an appendix.

Conditions. The "conditions" section should give real information about the initial conditions, not a statement of the obvious. The original said "given an 81-mm mortar complete with sight...." While such statements may be useful during development, they are devoid of useful information for the gunner. If the conditions statements are vapid, why not skip them? One should particularly skip statements about temperature, weather, time of day, clothing, and equipment provided, unless these circumstances are unusual, or not obvious. If in doubt, mention the condition, but generally there is no doubt about what would be normal and obvious.

The conditions statement should inform the soldier about extra people who will be provided, and any extra items of equipment (e.g., the direction stake), and their placement. The best way of doing this is in the first illustration. You should ask yourself, "what aspects of the initial situation might not be obvious to the soldier?"

The conditions statement should also tell the soldier what circumstances would lead to performing the task. For instance, if the task involves zeroing a weapon, the soldier should be told what conditions would make zeroing necessary or desirable.

Standards. As an operation is described, standards should be indicated by symbols in the margin. A "O" tells the performer that he will be checked on that step. A "●" tells the scorer what to check on the finished product. We propose the two symbols because it seems desirable to separate the "in-process" checks from the "product" checks. Also, the soldier wants to know what will be scored while he reads the task summary, not later. Avoid duplicating the description of checks in the standards section and in the instructions. The dot ("O") seems to be a good "population stereotype" for this purpose.

The original instructions included the ubiquitous expression "IAW (in accordance with) the performance measures below." That would be acceptable only if all actions are scored, which clearly is not the case. None of the pre-mont checks are scored, for instance. Some convention like the "O" is needed to distinguish what parts are scored, without redundant listing.

The "O" notation is most useful for procedures on equipment, where only certain responses are scored. If everything is scored or nothing is scored until the end, then it is less useful. For instance, in computation, each step must be correct and the soldier knows it. However, the "O" should be used whenever feasible.

References and Page Numbers

General references should be relegated to a section for trainers, rather than being included in instructions for each task. General references serve an archival function essentially. These should be accessible to the soldier, but not given priority. This rule does not preclude having specific references that are involved in task performance (e.g., maintenance manuals for troubleshooting). The references may also include alternate forms of instruction, such as the TEC programs, but it would be desirable to specify in each case how they are to supplement the instructions in the Soldier's Manual.

Page numbers must be reduced to a simple system so that the soldier or anyone else can find a given page without looking back to the reference. The present page numbering system has become incredibly cumbersome. Page numbers should be limited to seven "chunks" of information. That is to say, seven digits or letters or decimal points. Roman numerals should be eliminated completely.

Chapter 3

DRAFTING A TASK SUMMARY

This chapter gives step-by-step directions for developing task summaries that meet the criteria given in Chapter 2. This involves some steps that are not apparent in rules or the example. Also, it will help if the various considerations are laid out sequentially to avoid confusion.

STARTING CONDITIONS

We suppose that you are developing a task summary, and that the task has already been identified by the job analysis procedures discussed in TRADOC PAM 351-4, Chapter 1-7. There is probably an existing task summary, which is the best place to start.

From the start, you should focus on the goal, which is your revised task summary, and try getting there by the shortest possible route. That involves (1) studying only enough task information to give you a pretty good idea of how it is done, (2) doing a tentative task analysis, and (3) quickly drafting a task summary. Later you can correct any flaws through review, tryouts and successive revisions. Throughout the process, you collect only the information that you know you need. This allows you to see the significance of each item immediately, and to collect no extraneous information.

This process differs from the method described in TRADOC PAM 351-4 by de-emphasizing the preparatory phases, so you can devote more time to review, tryout, and revision. It is also likely to be quicker and more effective. We also try to give more specific guidance for task analysis. In your data collection and task analysis, you should not try for a monumental achievement, to last for ages, or even for the life of the project. Direct your task analysis to your immediate needs. If someone else can benefit from it later, that is a bonus. But if you try to provide everything that anyone might ever want in a task analysis, you will produce a mishmash that is good for nothing.

The system for developing task instructions is diagrammed in Figure 3-1. There are three phases of development: (1) input phase, consisting of collecting information from the various sources, (2) drafting the instructions, consisting of task analysis and preparation of the draft, and (3) getting feedback. These phases usually overlap in time, because the process is iterative (i.e., involves tentative drafts and revisions).

INPUT PHASE

This phase involves collecting information that you might need for the draft. This includes any of the items on the Task Analysis Worksheet, as listed in Figure 3-1 in the "INPUT" box. The immediate goal is to get a general idea of how to do the task, so that you can begin task analysis and drafting of the task summary. Begin with an existing task summary, if one is available. Revision is easier than original composition, and often you can use some of the pictures. You may want to check other sources of information to resolve ambiguities in the original. Usually any ambiguities will become apparent while studying references or during task analysis. Whenever you notice these ambiguities, make

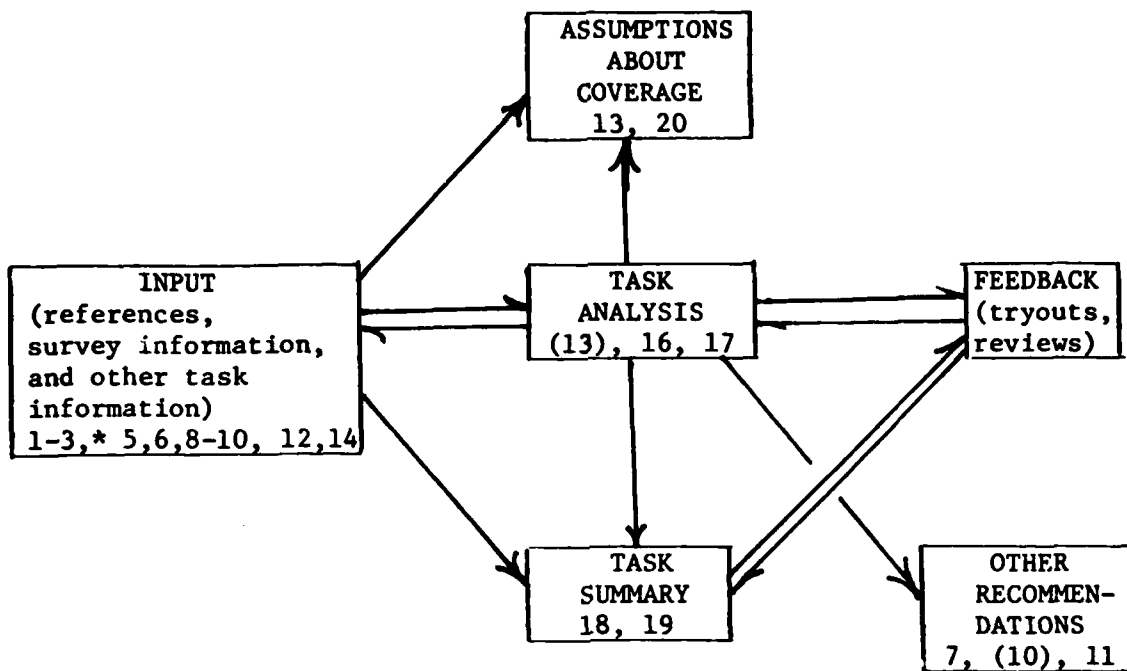

*These numbers refer to items on the JOB AND TASK ANALYSIS WORKSHEET, TRADOC Form 550, June 1979.

Figure 3-1. Information system for developing task instructions.

a note of them, because they often involve assumptions about what the soldiers should know beforehand.

BRANCHING INSTRUCTIONS

The rest of this chapter focuses on procedural tasks, which are the most common kind by far. A procedure is any fairly regular sequence of specific steps that do not require unusual strength or coordination. If the task you are concerned with is not a procedure, skip ahead to Chapter 4. (If in doubt, read the definitions of task types in the first section of Chapter 4.)

TASK ANALYSIS (FOR PROCEDURAL TASKS)

Task analysis is separation of a task into its component parts, and examination of relations between them. It is often confused with data collection, but task analysis is a distinctly different and important activity. Do not neglect the task structure diagram, because it is the basis of exceptionally clear and consistent task summaries.

Task Structure Diagram

Diagram the task structure by subdividing the performance in several stages. (We will illustrate the process with instructions from the 11C manual on zeroing an M203 grenade launcher, which are shown on the following pages.) Begin by writing the task name on the left margin of a piece of paper, and circle it. Then subdivide it progressively, working across the page as shown in Figure 3-2. At each subdivision try to keep the number of branches to an absolute minimum. Try for two branches, and limit yourself to three. Otherwise, you will be glossing over some distinctions you will need in listing the steps, or in wording the instructions.

Think of each subdivision in terms of results to be achieved, rather than the manipulations. Specify the manipulations in the very last circle at the end of the line (even if that does not constitute a branch). For instance, the "adj. windage" chain terminates in another circle with the note "by turning screw."

The sequence of task performance goes from top to bottom. If you have any operations out of sequence, erase them and change them.

You are probably going to have to do a lot of revising. This is why the notes in the example are abbreviated. For one thing, you are apt to subdivide in many-pronged branches. For instance, most people would initially subdivide "fire and adjust" directly into four operations: (1) "fire," (2) "measure error," (3) "adjust elevation," and (4) "adjust windage." Even if those are the steps that you finally list, give the intermediate breakdown because that will help you to see the relationships involved, and to express them in your writing.

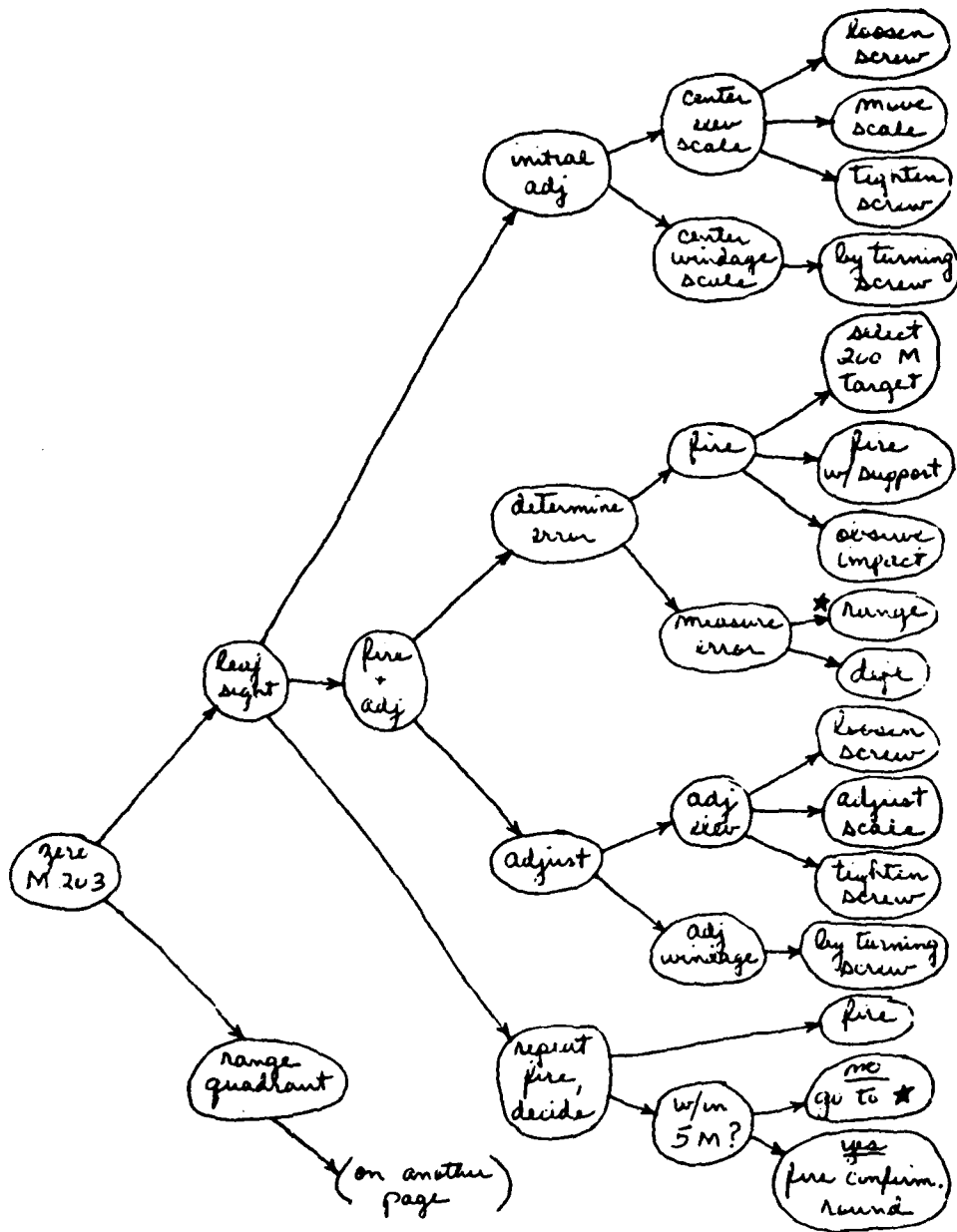

Figure 3-2. Task structure diagram.

TASK NUMBER: 071-311-2103

ZERO AN M203 GRENADE LAUNCHER

CONDITIONS:

Given an unzeroed M203 grenade launcher, five rounds of HE or TP ammunition (for each type sight), and a firing range.

STANDARDS:

Gunner will obtain an elevation and windage sight setting (on both leaf and quadrant sights) which will enable him to hit within 5 meters of his point of aim at a distance of 200 meters with two consecutive rounds.

PERFORMANCE MEASURES:

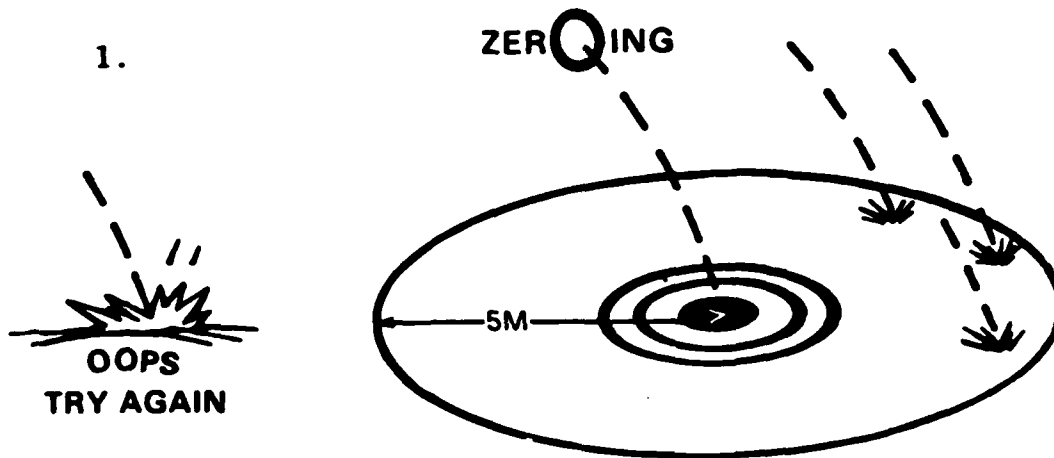

WARNING: DO NOT ZERO IN UNDER 100 METERS.

Select a target at 200 meters and fire a round. If the round does not fall within 5 meters of target, ZEROING PROCEDURES ARE CALLED FOR AND SIGHT ADJUSTMENTS MUST BE MADE FOR MORE OR LESS ELEVATION. Windage adjustments must be made for each firing. After each round fired make necessary adjustments until 2 consecutive rounds land within 5 meters of aiming point.

2-III-B-3.1

The point is to hit what you are aiming at. So, let's get familiar with the LEAF and QUADRANT sights.

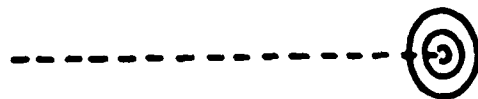
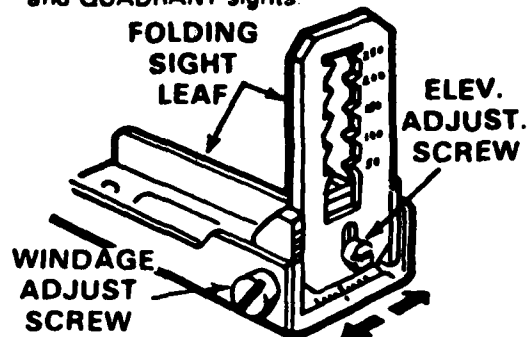

The LEAF SIGHT is used in conjunction with front sight post of the M16A1 rifle and provides range selection from 50 to 250 meters in 50-meter increments.

WARNING: The 50-meter mark on the leaf sight blade is marked in red to emphasize that this range is not to be used in zeroing procedures

2. Leaf sight zeroing:

- a. Select a target at 200 meters.
- b. Place the sight leaf in upright position.
- c. Place the center mark of the windage scale on the index line at the rear of the sight base.
- d. Loosen the elevation adjustment screw on the leaf sight and place the index line of the leaf sight on the center elevation mark on the sight mount.
- e. Tighten elevation adjustment screw on the sight leaf.
- f. Take a supported prone position.
- g. Aline target with the 200-meter increment of the leaf sight and the front sight post of the rifle.
- h. Fire a round, observe the impact, and make necessary sight adjustment.

(1) Turning the sight windage screw clockwise moves the strike of the round to the left; turning the windage screw counterclockwise moves the strike to the right. One increment in either direction equals 1½ meters at a range of 200 meters.

(2) Raising the leaf sight increases range; lowering it decreases range. One increment equals 10 meters at a range of 200 meters.

- i. Fire one or more rounds and make necessary adjustments after each round until a round has landed within 5 meters of the target.
- j. Fire a confirming round.

2-III-B-3.2

The QUADRANT SIGHT attaches to rifle handle/sight and has range from 50 to 400 meters in 25 meter increments. Elevation adjustment: 1 notch = 5 meters at 200 meters.

The rear aperture slides in or out for windage correction by depressing retainer. Vertical line denotes center. One notch equals 1.5 meters at 200-meter range.

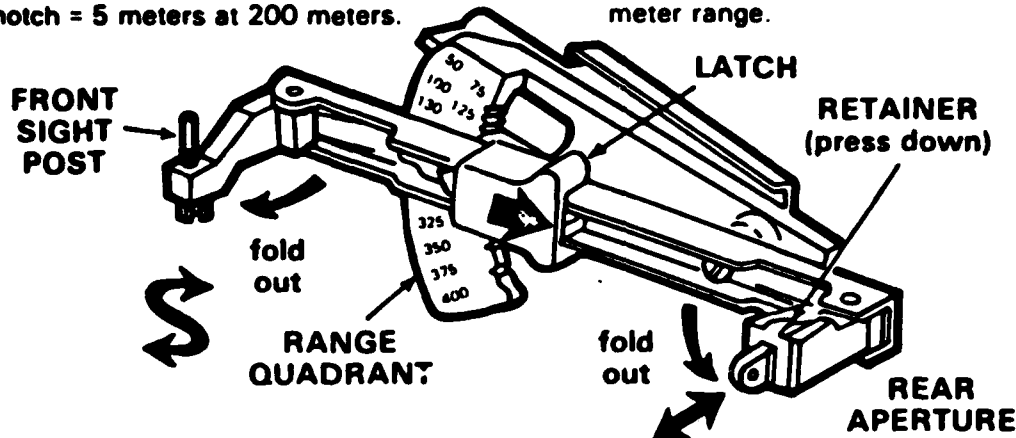

Turn front sight post right for less elevation and left for more elevation.

Slide in to move strike of projectile right; Slide out to move strike left.

3. Quadrant sight zeroing.

- a. Select a target at 200 meters.
- b. Insure that the sight is correctly mounted on the carrying handle of the rifle.
- c. Move the front sight post and rear sight aperture from the closed to the open position.
 - (1) Depress the rear sight retainer and slide the rear sight aperture to the left or right until the wide index line of the rear sight aperture is alined with the edge of the sight aperture arm.
 - (2) Move the front sight post to its highest position and then back off 2½ turns.
- d. Move the sight latch rearward and reposition quadrant sight arm to zeroing range (200 meters).
- e. Take a supported prone position.
- f. Aline target with the front and rear sights, using correct sighting and aiming procedures.
- g. Fire a round, observe the impact, and make necessary sight adjustment.
 - (1) For range adjustment, turn front sight post clockwise to decrease range and counterclockwise to increase range. One full turn equals 5 meters at a range of 200 meters.

2-III-B-3.3

(2) For windage adjustment, press sight aperture retainer and move rear sight aperture away from barrel to move trajectory of the projectile to the left. Move the rear sight aperture toward barrel to move trajectory to the right. One notch on the rear sight aperture equals 1½ meters at a range of 200 meters.

h. Fire one or more cartridges and make necessary adjustments after each round. When a round has landed within 5 meters of the target, the weapon is zeroed.

i. Fire a confirming round.

NOTE: If the individual has not zeroed after firing five rounds, his weapon will be inspected to insure that it is assembled and functioning properly. After the weapon is checked the individual may be given another opportunity to zero.

WARNING: DO NOT FIRE THIS LAUNCHER UNTIL YOU HAVE READ THIS TASK.

USE AMMO MANUFACTURED TO U. S. SPECIFICATIONS ONLY.

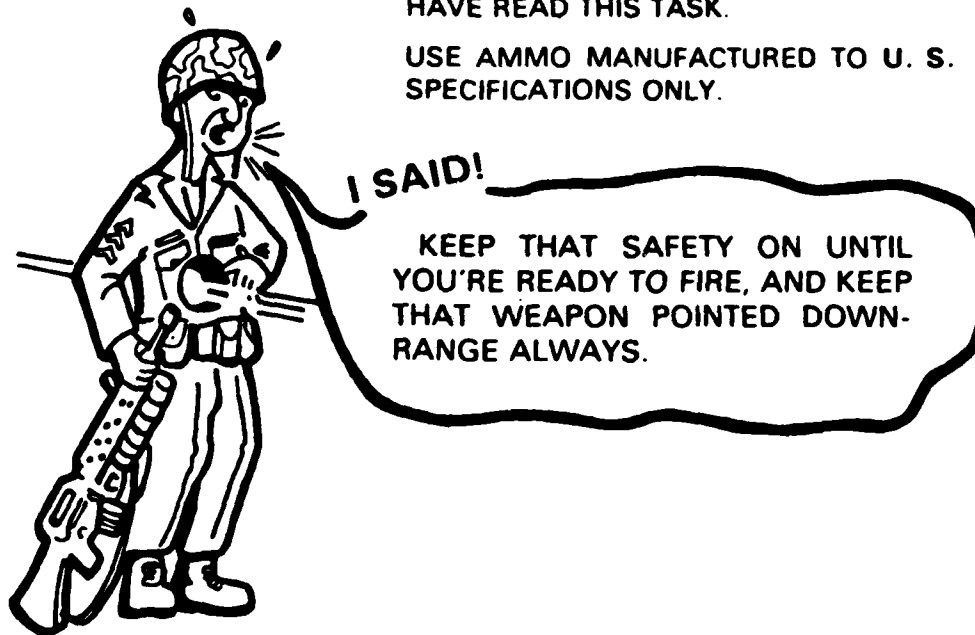

REFERENCES:

FM 23-31, 40-mm Grenade Launcher, M203 and M79, May 72 (chap 6, pages 6-12, 6-13, para 6-18 -- 6-21)

TM 9-1010-221-10, Operator's Manual 40-mm Grenade Launcher M203, Jul 74 (pages 16-19; 24)

TEC Lesson 940-071-0088-F, The M203 Grenade Launcher: Zeroing and Target Engagement

2-III-B-3.4

Different kinds of tasks have different kinds of branching in their structure diagrams, especially in dividing the total task and major subtasks. For instance, in "perform mouth-to-mouth resuscitation and external heart massage," the first subdivisions should look like Figure 3-3. Notice that those subtasks imply a definite sequential arrangement, with the first one being contained in the second, and the second being modified by certain compromises to form the third subtask. In contrast to that, zeroing the M203 contained two subtasks, one for each sight, which could be performed equally well in either sequence, and which were parallel operations on similar devices.

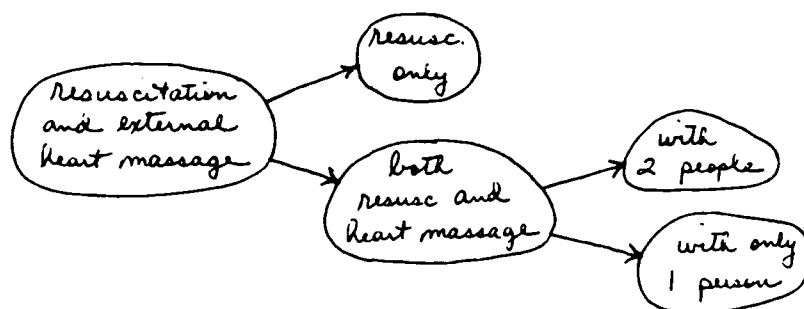

Figure 3-3. Task structure diagram (incomplete) showing a different kind of branching.

You are very likely to discover inconsistencies in various references on the way the task is done. There are also apt to be inconsistencies between the references and the way it is done in the field. Sometimes the procedure described simply will not work. Diagramming task structure is an excellent way of discovering such discrepancies. In such cases, diagram what seems to be the most sensible, straightforward procedure, and make a note to resolve the inconsistencies later.

Selection of Major Steps

Select major steps from your task structure diagram. These are the sections that you will number 1, 2, 3, and so on. You should select these at a proper level of generality so that they make sense and are easy to remember. Draw a line down your diagram from top to bottom, connecting the nodes that you want for the steps, as shown in Figure 3-4. That line must cross all branches at one (and only one) level of generality. That means you must not cross any branch twice, and you must not go through any node and one of its components. The resulting list of steps is:

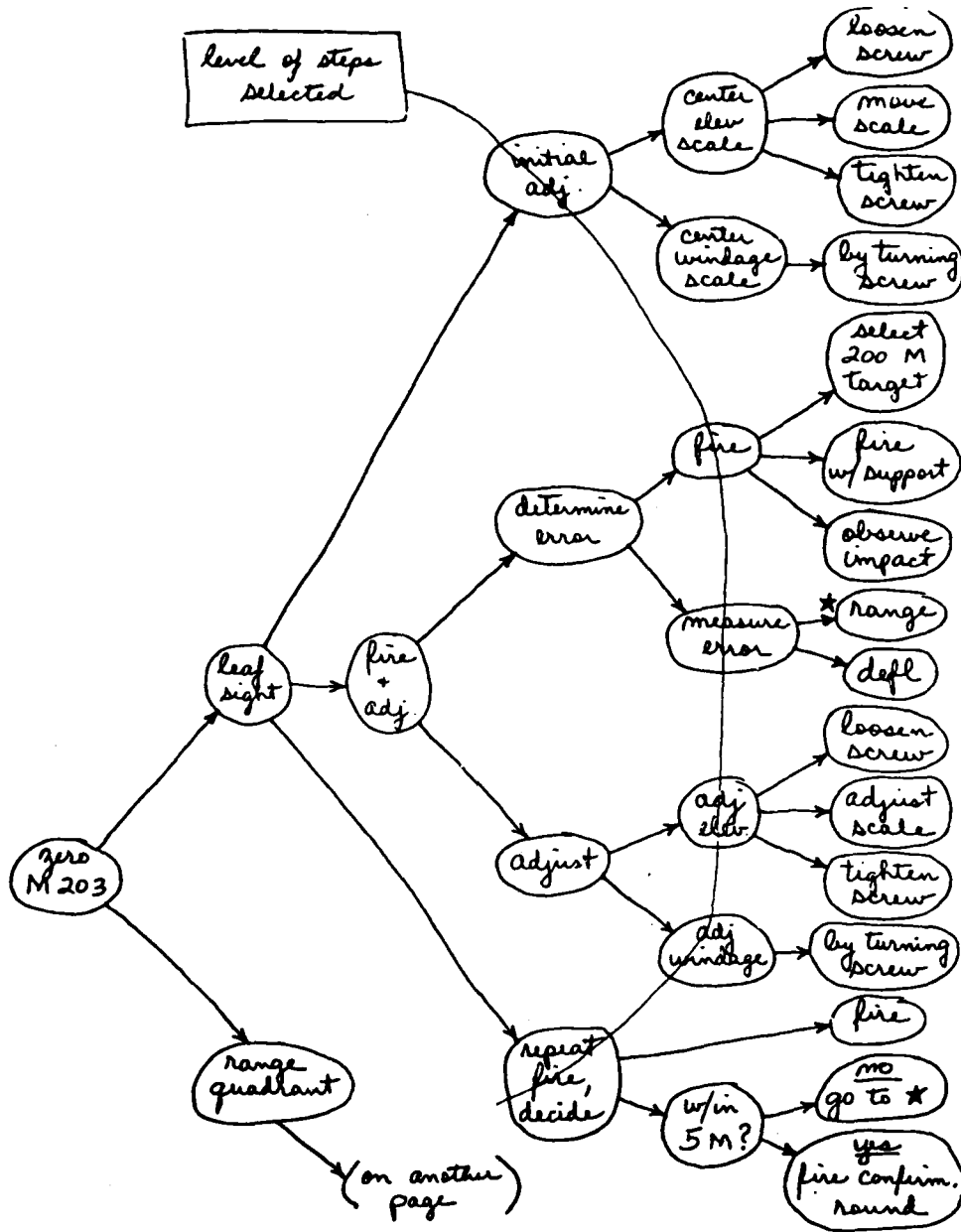

Figure 3-4. Determination of major steps (numbered).

1. Initial setting,
2. First round,
3. Measuring the error,
4. Adjusting elevation,
5. Adjusting windage, and
6. Subsequent rounds.

For the other subtask (with the other sight), the numbering should start again with 1. Roman numerals and capital letters should be used for higher level divisions, as needed. That usually involves subtasks or non-task activities, such as checks by the scorer.

Use your judgment in selecting steps at a moderate level of detail. You do not want steps so small that they seem to get lost in the nitty-gritty. Yet you do not want them so large that they are abstract or vague. Many people use the rule of never having more than four or five undifferentiated items in a list, based upon limitations of human short-term memory. But that rule can be stretched somewhat by naming the steps so as to cluster them. For instance, the steps of "adjusting elevation" and "adjusting the windage," occurring together in the sequence, can be mentally "chunked" into one kind of operation. But you should never have more than 10 numbered steps.

WRITING AND ILLUSTRATING EACH STEP

Now write instructions and design illustrations for each step. Numerous rules for doing that are given below, exemplified by the revised task instructions that appear on the next two pages. Read this example first, then read the discussion below on how to produce this kind of result.

Statement of Objectives

Review the statement of objectives in the original instructions. The task title was simple and direct, so it was not changed.

State the conditions in terms of the circumstances that brought the soldier to perform the task, and perhaps picture the situation at the start, if that is significant. In our example, the only reason for doing the task is that the sight adjustments are out of tolerance, or at least suspect. The firing range seems too obvious to mention; it is hard to imagine any soldier's not knowing that firing is done on a firing range, and not elsewhere.

State the standards directly, using second person. Be brief.

Writing Techniques

As you write, visualize the action and describe it in specific terms. Whenever the action can be illustrated more effectively than described, use integrated illustrations (which are discussed separately, below, for convenience).

Level of detail. Your instructions should focus on results at the most general level you can justify, rather than on detailed manipulations. To do this, go to your task

ZERO AN M203 GRENADE LAUNCHER

Conditions: Your M203 Grenade Launcher has a consistent error of more than 5 meters at a range of 200 meters.

Standard: For each sight, adjust elevation and deflection to hit within 5 meters, twice in a row, using no more than 5 rounds. (Steps marked "0")

Procedure:

A. LEAF SIGHT

1. Initial setting. After loosening ELEV. ADJUST. SCREW, center the index mark on the elevation scale. Then tighten screw.

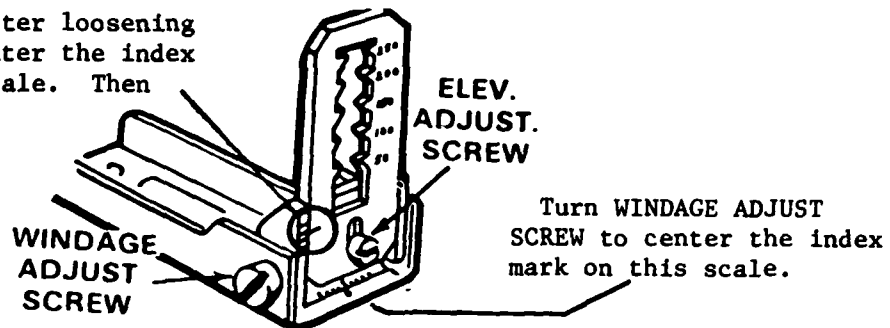

2. First round. At a firing range, select a 200 meter target. Fire at base of target from a supported prone position. (This means the weapon is resting on something solid, like a sandbag).

WARNING: NEVER ZERO UNDER 100 METERS

Observe the impact. Think of moving the point of impact toward your aiming point. That's the direction you want to move the sight.

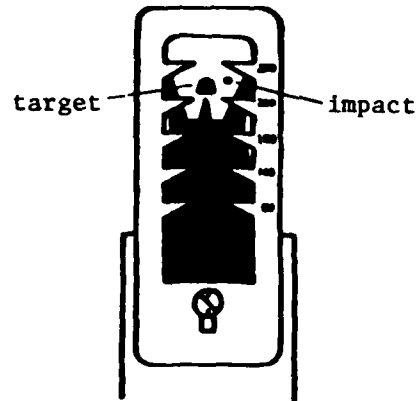

3. Measuring the error. Go downrange to the point of impact, and measure the range error and the deflection distance separately. In this example, suppose that the round impacted 6 meters over the target, and 3 meters to the right.

4. Adjusting elevation. Lower the sight 1 mark for every 1.5 meters that the round went over the target. In this case, lower the sight 4 marks (for 6 meters over).

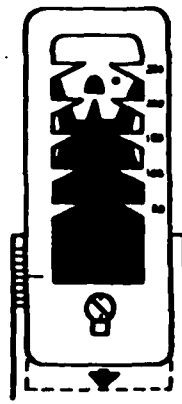

5. Adjusting the "windage." Move the sight by turning the screwdriver in the direction shown. Move it 1 mark for every 1.5 meters error in deflection. In this case, that's 2 marks (for 3 meters error).

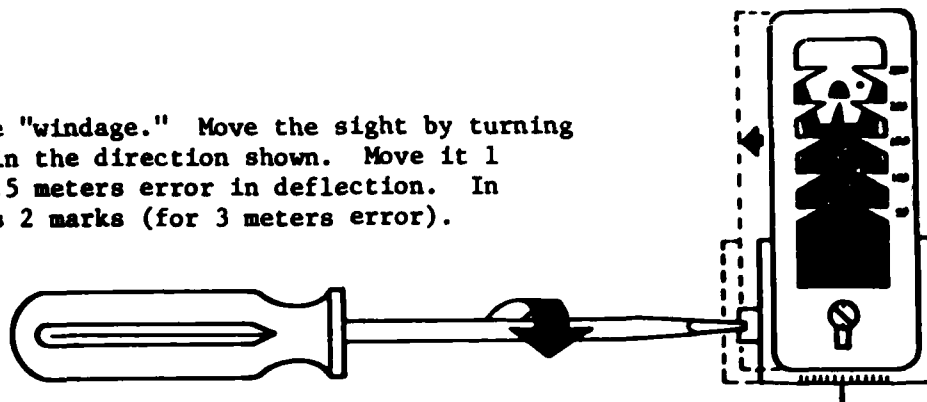

Windage Scale

- 6. Subsequent rounds. Fire another round. Determine whether the impact is within 5 meters of the target by measuring directly across the ground. If so, fire a confirming round, which should also hit within 5 meters. If not, repeat the procedure by going back to step 3. The whole procedure should require no more than 5 rounds, including the confirming round.

B. RANGE QUADRANT SIGHT

Sometimes you may also want to use the range quadrant sight, which has extended range marks out to 400 meters. Zeroing this sight will take another 5 rounds.

1. Mounting the QUADRANT sight ---, etc.

structure diagram and find the numbered step you are working on. Then work across one level (to the right). For the first step, that is "center elev. scale." Is that enough detail? Probably not, because the response has not been mentioned before. Moving across to the next level, the diagram reads "loosen screw, move scale, tighten screw." That is put into sentence form and connected to a picture of the sight. It is connected to the index scale rather than the screw to focus attention on results rather than manipulations.

Later on (in step 4) the elevation is adjusted again. There the instructions simply say "lower the sight...", assuming the soldier knows how to accomplish that result. That assumption is based upon three factors: (1) it was instructed previously, (2) it is a common practice in everyday life, and (3) the soldier could probably discover how to do it on the equipment. Those are the three factors to consider in justifying instructions at a more general level: previous coverage, common practice, and discovery.

Notice in steps 4 and 5 that the illustrations show only the scales being used for each step. The general rule is to vary the amount of detail shown in illustrations for each step, to focus attention on the cues that are needed.

The above method of using the task structure diagram will work for generating most of the writing, and for connecting it to illustrations of the sight. That is why it is worth painstaking analysis. For other examples, compare the details of the revised instructions with the corresponding points on the task structure diagram (Figure 3-3).

Prerequisites. Another way of reducing wordiness is to eliminate anything that is covered previously in the manual. There is no point in repeating long sections. Whenever you make assumptions about what the soldier should know beforehand, make a note of it. Here we are only concerned with specialized information, not the sort of thing the soldier might pick up in his civilian education. For instance, in step 2, the instructions say "fire at base of target from..." That implies the soldier already know how to aim. The soldier should learn aiming in the task on target engagement. But the current Soldier's Manual puts target engagement after zeroing the M203, so either the sequence should be changed, or else aiming should be added to the instructions under development. It is preferable to change the sequence of tasks, because target engagement is the basic function for which the M203 is intended. So one should make a note to try to get it changed, and if that cannot be done, the task instructions will have to be amended accordingly. That note should be recorded in item 20 of your Task Analysis Worksheet (June 79 edition).

Story line. Notice that the revision had a clear indication of the sequence to follow in reading, but the original had a lot of random notes and pictures without indication of sequence. Be sure there is an obvious sequence, by using techniques of format, wording, and numbering.

The story line can also help you sequence your writing, whenever you use traditional sentences and paragraphs. The basic elements are short phrases, which you juggle mentally. It's like stringing beads; you sequence the phrases on a story line. Add punctuation and connectives as needed, keeping the sentences short. Let each sentence continue where the previous one left off. You should use the context rather than regarding each sentence as independent.

Basic Task Logic

Go to your task structure diagram and look for an operation that involves some reference to other steps (e.g., a decision). In the M203 example, that would be the "repeat" operation. That sort of problem will require special attention to make the instructions simple, logically rigorous, and expressed in common language. You should also consider ways of simplifying the decision in your diagram, because you may have overcomplicated the situation.

Examples and Illustrations

Embedded examples. Use one specific example throughout. Such an "embedded" example allows the soldier to apply the instructions step-by-step as they are given, instead of at the end. People don't understand instructions until they are applied in specific situations, and it's important for the soldier to understand each step as it is read.

Also, do not try to "define" the operation in abstract terms. If there is doubt about whether the example will cover other instances, refer to the discussion of "insuring coverage" at the end of Chapter 4.

Visual techniques for motion (applicable only to procedures with equipment). Indicate direction of motion visually by arrows and by "ghost" images for the terminal position. Do not rely on words such as "left-right" or "clockwise-counterclockwise." In the original instructions those "word" conventions were compounded with "wordy" references to remote illustrations (instead of notes alongside). The result was enough to make your head swim (i.e., it tended to exceed the capacity of one's short-term memory).

Note particularly in step 5 that there were three visual elements to be associated: (1) the error of impact, represented by the dot and target, (2) the sideways motion of the sight to correct for that error, and (3) the direction of turning the screwdriver to move the sight to correct the error. Show all such motion in one direction only, corresponding with the example. The soldier can easily generalize to correction in the opposite direction. But he will be confused if you try to say it every which way within a step. In this case, we do not dare let the soldier discover the direction to turn the screwdriver on the equipment, because he is apt to forget where the index mark was before correction. Then he would have to begin the whole procedure again by firing another round.

I expect purists to complain "that's lopsided--you didn't cover all combinations of motions!" But it seems better to obey the law of "specificity" than to please an esthetic preference for symmetry.

Kinds of illustrations. Notice that all of the illustrations showed the focus of attention. The viewpoint was subjective. There was no need for other illustrations to show "configuration" of task elements, because there were no significant items outside of the focus of attention. Many other parts of the weapon were involved, but these are obvious to anyone who is used to firing it. Also, note that the only significant items were labeled. For example, the M16 front sight was not labeled because it would be recognized by anyone familiar with the weapon.

Other Practices

"Procedure" section. Following "conditions" and "standard," the title "procedure" is used to cover the main body of task performance instructions. That term is simpler and more accurate than the former term "performance measures." Task summaries include much more than criteria of correct performance.

Warning. Place warnings after the operation to which they apply. Warnings are modifiers of the basic operation, so they make no sense when stated first. To minimize the chance of anyone's executing the action before reading the warning, box them off and place them closer to the paragraph above than to the paragraph which follows, so that it is clear where they belong. If there are still misgivings about reading the warning in time, add a "dependency" arrow, as follows:

2. First round. At a firing range, select a 200 meter target. Fire at base of target from a supported prone position (that means the weapon is resting on something solid, like a sandbag).



WARNING: NEVER ZERO UNDER 100 METERS

References. Mention only those references used in actual performance of the task. Other task references should be listed in an appendix for trainers and developers.

Laying Out Text and Illustrations

You should prepare a typed draft to get feedback, even if your task summary will eventually be printed. In designing page layouts, a handy technique is to paste typing and pictures on a "layout matrix" like that on the next page. The layout matrix is to assist typists in spacing, based upon standard elite type. The horizontal lines are to indicate when to double and triple space. The matrix may be reproduced locally. It is especially handy when spacing is tight.

Chapter 4

DIFFERENT KINDS OF TASKS

In writing a task summary, many of the particular problems you face are determined by the kind of task involved. Now we are going to give specific suggestions for each kind.

SECTION 1: CLASSIFICATION OF TASKS

MAJOR KINDS

In classifying a task, first determine whether it is a procedure or a reasonable facsimile thereof, because procedures are the simplest kind to teach. The vast majority of military tasks qualify as procedures, so that has been the focus of our attention.

A task is considered a procedure if it meets three criteria: (1) it involves responses that can be specified in concrete terms, (2) no response requires unusual strength or coordination, even for novices, and (3) the responses are performed in a fixed sequence, more or less. These characteristics make procedures straightforward to perform and easy to teach. When a task does not meet one of these characteristics, it is classified as another kind of task, as diagrammed in Figure 4-1. Each of the decision points are discussed below, in terms of the resulting classification when one of the criteria is not met. A more detailed classification of tasks is given in Appendix A (foldout sheet) along with task examples for various categories.

Criterion-driven Performance (i.e., "soft skills")

The first question involves whether the actions can be specified in concrete terms. By "concrete" we mean a description in terms of a picture or directly observable event. For example, a task that would not meet this criterion is "prepare and conduct performance-oriented training." Therefore, we would classify it as "criterion-driven performance." "Performance-oriented training" can perhaps be specified, but not in concrete terms. For instance, such training follows the job sequence, which cannot be observed directly, but can only be inferred from knowing the sequence in job performance and comparing that with the sequence of instruction. Any task that qualifies as criterion-driven performance involves abstract criteria, not concrete ones. Tasks of this sort are often described as "content-general." The criteria involve matters of form rather than content. Generally, this sort of task also lacks a regular sequence of performance, and that's another reason why it is difficult to instruct. Many supervisory tasks are of this sort. We shall consider this kind of task in Chapter 5.

Strength and Coordination

The second question involves whether the responses are rather easy in terms of strength and coordination. Here we are concerned with the overt responses, not any reasoning that might be involved. A practical way to determine this is to find a novice

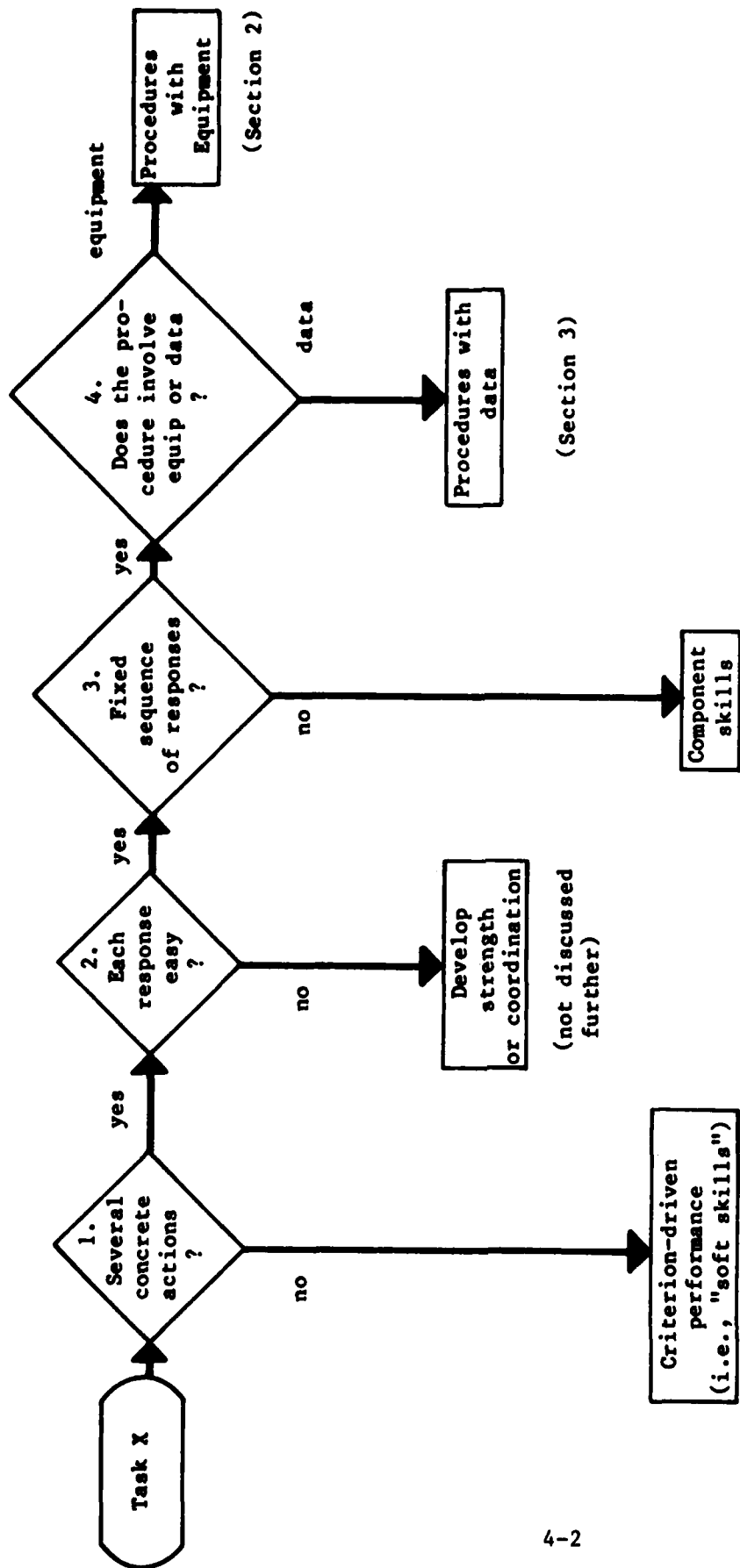

(Section 5)

(Section 4)

Figure 4-1. Flow chart for classifying a task. (You only need to read the section that applies to the kind of task summary that you are writing.)

and try to "talk him through" the task. If he succeeds, the task does not require development of strength or coordination.

Of course, strength and coordination are relative terms, so the answer may depend upon which soldiers are tested. However, there is a modicum of strength and coordination that may be expected of any normal adult, and most Army tasks are clearly within those limits.

If a task is marginal in requirements for strength and coordination, then the general approach is to teach it as a procedure first, to get a first approximation of the desired performance, and then provide opportunity for much practice. For instance, in throwing hand grenades, the first thing to do is to teach how to hold the grenade, when to let go, and so on, and then to provide practice under realistic conditions. There is no conflict between one kind of practice and another. The reason for asking this question is to determine whether there is any need at all for exercises to develop strength or coordination.

Rifle marksmanship is another example of this sort of skill. A trainer can go a long way in teaching marksmanship as a procedure (i.e., "by the numbers") but there comes a time to stop talking and start practicing. A few hints may continue to be useful throughout training, but the emphasis definitely shifts from "instructions" to "practice."

We will not be discussing strength and coordination elsewhere in this manual because there is not much to say that would be useful to you. If you are writing instructions for tasks of this sort, describe the procedure for getting started and a method for scoring performance, give a few helpful hints if you know any, and leave it at that.

Component Skills

Now suppose that a task meets the first two criteria, but there is no fixed sequence involved in the performance. There is nothing mysterious or ephemeral about such skills, because they do meet the criterion of responses defined in concrete terms. Some examples are: (1) combat vehicle identification, (2) using hand signals of various kinds, and (3) reacting to flares. All of these skills involve such brief episodes of behavior on the job that it would not work to teach them as a continuous process. Instead, they are taught as special exercises based upon similarity of content, rather than upon occurrence together in practical performance. In reacting to flares, for instance, a soldier must decide what to do in a few seconds at the most, and another choice about flares is not apt to occur for a long time. The special problems of analyzing such tasks are discussed in Chapter 5.

Sometimes a task may involve some "branching" (i.e., decision points), but also many strings of responses in regular sequence. For example, troubleshooting involves both branching and regular sequences, so it is difficult to classify. In such cases, you should generally consider the task a procedure, because procedures are usually easier to teach. For example, electronic troubleshooting can be reduced, for the most part, to Fault Isolation Procedures (FIP). Each FIP is practiced as a long, fixed procedure, making note of each choice point where the action could have taken a different turn. Then the FIP is practiced another way, following a different path. The trainer checks to be sure that all kinds of choices have been made, so that a soldier is prepared to cope with any pattern

that may happen. Yet practice of FIP remains very much like practice of other procedures.

Procedures With Data

Now suppose that a task meets all three criteria to qualify as a procedure. Then you should ask yourself the fourth question in the flow chart, about whether the procedure is primarily dealing with data (i.e., facts and figures) or equipment (such as weapons, machines, or survival gear). If it involves mostly data, it will be much easier to picture the stimulus displays (e.g., firing tables) and the responses, which are usually written. Even if the responses are not written, they can be pictured as if they were written, without serious distortion. Procedures with data also involve special problems, especially the difficulty of generalizing from particular examples to the operations involved in each step.

Procedures with data have traditionally been distinguished as separate tasks, even when they are performed along with other duties. The reason is that they require different kinds of training facilities and methods. For example, navigation in an aircraft has always been considered a task separate from flying, even if the pilot does both tasks. The advantages of considering data processing as a separate kind of task are so great that the distinction is made whenever possible. Most procedures with equipment involve some elements of data (e.g., sight data for a mortar), and for those aspects the special problems of data procedures should be considered.

Procedures With Equipment

Procedures with equipment involve illustrations and other techniques for describing the movement of equipment, components, and people. A typical example is the instructions for ground-mounting a mortar, which we discussed in Chapter 2.

The term "equipment" should be broadly construed, to include everything but data. You could think of them as procedures with "things," but that term has an abstract quality, which makes it harder to apply in most cases. Sometimes the "equipment" is minimal, particularly with procedures for survival on the battlefield, which we classify in this category. One reason for sorting tasks into this category is the need to illustrate something besides paperwork in the instructions.

A note of caution: when a task involves using a job aid, such as a Lubrication Order, the most important considerations may be in learning to interpret the symbols and format of the job aid. We discuss these below under "Component Skills (communication)." In this example, the actual lubrication of equipment is relatively simple.

SUBDIVISION OF TASK CATEGORIES

Glance over the detailed classification system in order to get a general idea of where we are going (Appendix A). The outline should give you an impression of how comprehensive the system is, and it may allay some fears that the system will be difficult to apply. It may also help you classify the task summary that you're writing. But please

do not become bogged down in details yet, because the classification will be explained below, one section at a time, as it is applied.

BRANCHING INSTRUCTIONS

Now skip to section 2, 3, 4, or 5, depending on the kind of task summary you're writing.

SECTION 2: PROCEDURES WITH EQUIPMENT

Various circumstances affect the kind of task summary you write. The most obvious differences are in the kinds of illustrations, and most of the suggestions concern different ways to use pictures.

The tasks listed as examples in the various categories are selected from MOS 11B (infantryman), 11C (indirect fire infantryman), and 19E (armor crewman). Our focus on these MOS probably biases the system, although other kinds of tasks have been considered.

BRANCHING INSTRUCTIONS

Generally, you will only need to read the subsection for the kind of task summary you're writing: Construction, Machine operations, Field operations, or Maintenance (these are defined below). Within the subsections, you should focus on the most particular kind of task, in order to incorporate those suggestions in your draft. Then skip to the next chapter.

CONSTRUCTION

Tasks of these category involve preparation of crafted products, including defensive positions, adjuncts to those positions, and camouflage.

Your main consideration in developing instructions for such tasks is that the standards are characteristics of the finished product, rather than the steps that produced it. The standards usually should be specified in an illustration, such as Figure 4-2, which show dimensions of a mortar position. The few restrictions on process are qualifications rather than steps in the construction. A common restriction is priority (i.e., what should be done first). Another kind of qualification applies to certain aspects of the construction process (e.g., where to get the branches for camouflaging a position). Such qualifications can be described in words, without ambiguity. Most of the instructional information can be illustrated using a picture of the product with connected notation specifying the standard. Some other examples of construction tasks are: camouflage/conceal self and individual equipment, construct individual defensive positions, prepare and use aiming and

firing stakes for the M16A1 rifle, camouflage/conceal defensive positions, emplace/recover pyrotechnic early warning devices, construct mortar position.

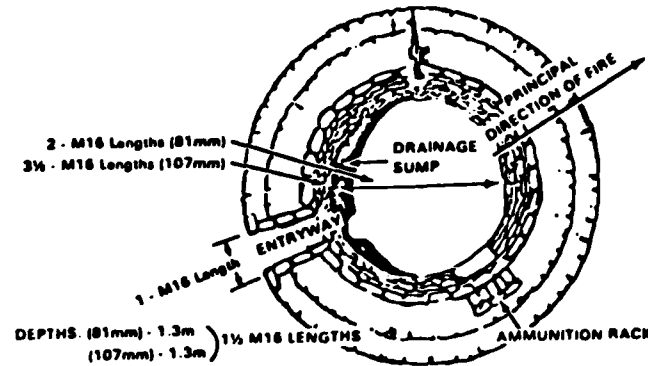

Figure 4-2. Specifying standards characteristics for a "construction" task (11C,* p. 2-II-B-10.1)

This category does not include mechanical systems that are assembled and tested in stages; those are discussed below under "Machine operations, assembly." However, if a mechanical assembly can be specified entirely by characteristics of the finished product, then it is classified as a construction (e.g., the tripwire warning system illustrated in Figure 4-3).

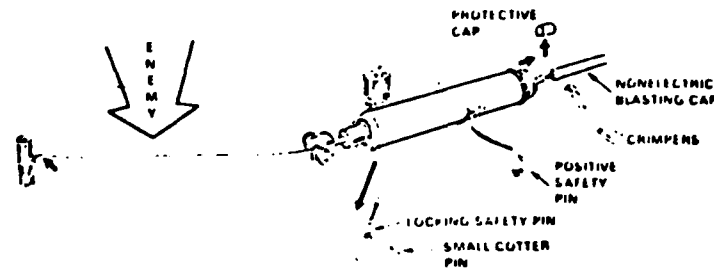

Figure 4-3. Product specification in a mechanical assembly (11C, p. 2-II-C-10.4)

*All examples in figures in this chapter are from FM 7-11C, July 1978, unless otherwise specified. All of those are reduced one-third from the original.

For some of the instances, the standards are easy to specify, such as the dimensions of a mortar position. In other instances, the standards are vague and difficult to illustrate, such as the patterns of good camouflage (e.g., Figure 4-4). Those instances require very good pictures, and perhaps numerous comparative illustrations.

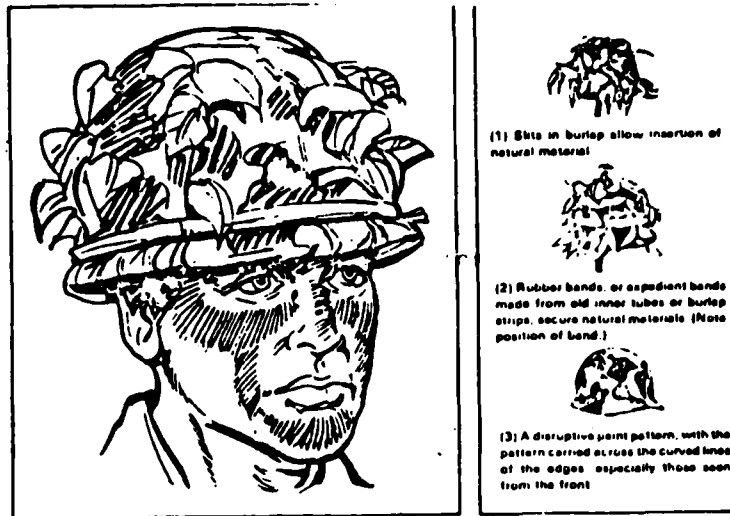

Figure 4-4. Illustration of a construction with vague characteristics (11C, p. 2-A-1.2)

These tasks involve so little emphasis on sequence of steps that they hardly qualify as procedures. You probably should not try to diagram the task structure. (This applies only to this kind of task.)

MACHINE OPERATIONS

Machine operations are tasks in which weapons or other mechanical systems are instrumental in achieving task objectives. The standards are specified in terms of the intended functions of those systems. (Maintenance is not included.)

Setup

Setup tasks involve preparations for the primary functions of the systems.

Assembly and disassembly. Assembly tasks consist of putting together the components of the system. Examples include ground-mounting a mortar, installing field telephones, and constructing an electric detonating assembly. You should illustrate the various stages of assembly, without radical changes in viewpoint. But do not illustrate trivial variations that could better be described in words. For example, consider the elaborate instructions on testing a detonating circuit in Figure 4-5, compared with the revision in Figure 4-6.

b. To check the firing wire (using M51 test set):

(1) Separate the firing wire conductors at both ends, and connect those at one end to the test set binding posts. Actuate test set. The indicator lamp should not flash. If it does, the firing wire has a short circuit (figure 2a).

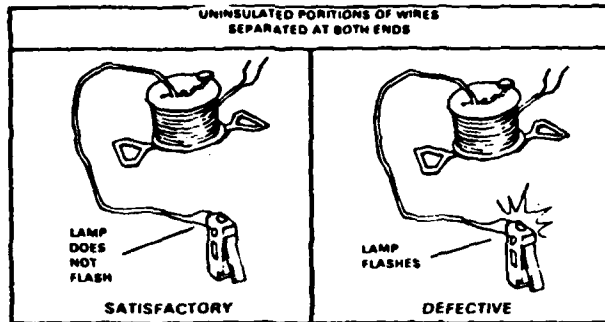

Figure 2a.

(2) Twist the wires together at one end, and connect those at the other end to the test set posts. Actuate test set. The indicator lamp should flash. If it does not flash, the firing wire has a break (figure 2b).

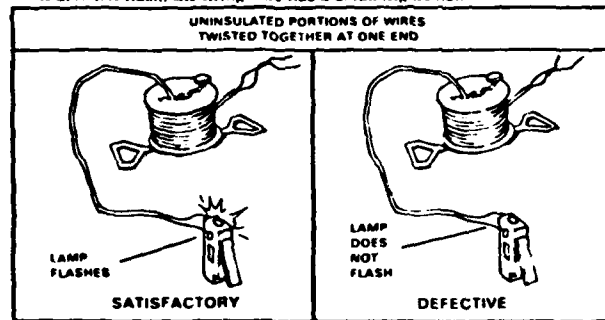
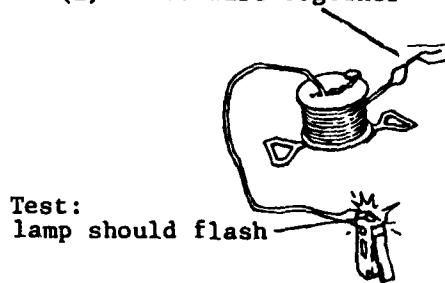

Figure 2b.

Figure 4-5. Original instructions on testing during assembly.

b. To check the firing wire:

(1) Twist wire together



(2) When untwist wire and test again: lamp should not flash

Figure 4-6. Revision, which integrates text and illustrations.

If there is a standard configuration of people and equipment at the start of the task, you should illustrate it. These tasks may involve some alinement of a sight picture, but the sight picture is not prominent, as it is in many tasks of the "zero and adjust" and "target engagement" categories. Generally there is a need to illustrate some details of mechanical manipulations.

Zero and adjust. Zero and adjust tasks involve precise alinement of the weapons systems and sights, usually in relation to some feature in the environment (e.g., aiming posts). Some examples are: zero an M203 grenade launcher, zero an M16A1 rifle, zero the AN/PVS-2 when mounted on an M16A1 rifle, lay mortar for direction using direct alinement method, lay mortar for direction using M2 aiming circle, lay mortar for direction using M2 compass, boresight 81mm mortar, boresight 107mm mortar, prepare a range card for a tank, select and occupy firing positions, zero a main gun.

Often the main picture to illustrate is a sight picture, as in zeroing the M203. You may need no other kind of illustration. (Illustrating a sight picture is discussed below under "target engagement.") You may consider illustrating the standard orientation of the weapon in the environment using a top view as a visual concept for performing the task.

Operate

Tasks of this sort involve performance on the system in its normal configuration.

Target engagement. Tasks of this sort generally involve a sight picture, which is apt to be prominent in the illustrations. Some task examples are: engage targets with an M203 grenade launcher, engage targets with a 90mm recoilless rifle, engage targets with an M72A2 LAW, use precision fire, use battlesight, adjust fire from a subsequent fire command, adjust fire using burst-on-target.

When a sight picture is illustrated it should usually show the desired alinement of reticle on target (Figure 4-7). But when an illustration is to show movement of the reticle in response to a burst, it should employ arrows and "ghosting" of the terminal position. For example, see the illustration of burst-on-target in Figure 4-8. (Note how similar that is to the illustration in our revision of the M203 instructions in step 2 under "observe the impact.") Burst-on-target has always been a difficult concept to illustrate because comparative illustrations do not give a vivid idea of motion. It is difficult to communicate the idea that the burst should be visualized as moving with the reticle pattern, rather than being associated with the ground.

Sometimes the system involves no sight picture. Two examples are: engage targets with M85 machinegun, and fire a Claymore mine. In such instances the task is more like other normal and emergency procedures on machines.

Target engagement tasks generally include immediate action on the same system, as they appear in the Soldier's Manual. Our classification system distinguishes immediate action as another kind of task because of differences in the methods of writing and illustrating the instructions. Refer to the discussion of "immediate actions" below if you are including both kinds in your task instructions.

• left edge of
direction stake
(+ 2 mils)

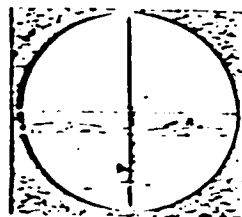

Figure 4-7. Sight picture showing alinement
(from Chapter 2 of this report).

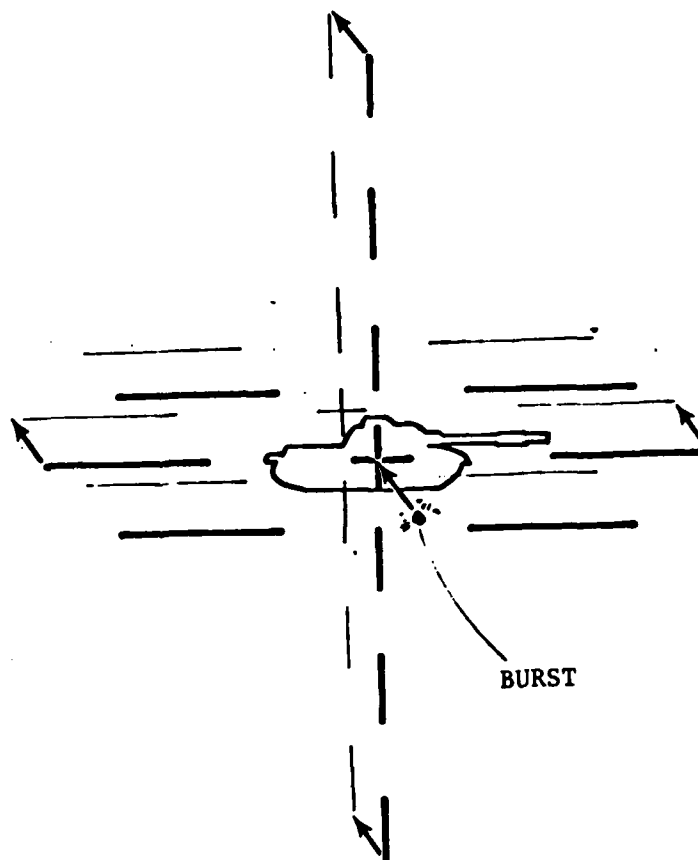

Figure 4-8. Burst-on target (BOT). (Think of moving
the point of burst onto the target. That's
the direction you want to move your sight.)

Other normal operations. This category includes tasks involving the intended use of mechanical systems, other than target engagement. An example is "start and stop a tank engine." We do not include "driving a tank" because that task is primarily a matter of choosing the best path, as it is now written, so there is no regular sequence. That is quite different from flight procedures, for instance, which would qualify for this category. Flight procedures involve primarily responses to cues within the cockpit, hence they involve a fixed sequence of events.

For tasks of this sort, consider providing a subjective view of the work situation, which may function as a mockup does when pilots practice flight procedures. Such mockups are generally very effective training devices for learning procedures, even when scaled down. "Mockup" illustrations should picture all displays and controls that are used, from a subjective viewpoint, with labels for the items mentioned in the narrative.

Immediate action. This category includes immediate action tasks and similar emergency procedures. Such tasks are generally short and performed under stress of time and danger. They differ most from target engagement in that a sight picture is not involved. One instructional problem is frequent branching. Instructions should be written as if the procedure were linear, while indicating where there is a choice point.

FIELD OPERATIONS

This category includes various procedures involving non-mechanical manipulations. These are sometimes called "man-ascendant" procedures, as opposed to "machine-ascendant" procedures. Some examples are: detect enemy mines, destroy a mine in place, recover a tank by self-recovery means, apply the four life-saving measures, administer antidote to a nerve-agent casualty, decontaminate self, equipment, weapon, supplies and tank, administer artificial respiration (mouth-to-mouth).

Comparison With Machine Operations

Although such tasks almost always involve manufactured devices of some sort, the standards are not specified in terms of such instruments serving their primary function, as they were for machine operations. A mechanical system may be involved as the object of the operation (e.g., recover a tank), but that is quite different from the machine being instrumental in the procedure.

Comparison With Construction, Assembly

Field operations also differ from construction in that the standards are not specified in terms of characteristics of a product. Field operations involve several stages of development, and in that respect they resemble assembly procedures. Field operations differ from assembly by more critical involvement of the soldier, and less emphasis on the mechanical parts.

Approach

First you should consider illustrating the "kernel" situation. You may also need to illustrate the initial conditions as a "configuration." Sometimes you should illustrate several response cycles. Often there is positioning or movement of the soldier's body or hands, which usually should be specified in illustrations (e.g, Figure 4-9).

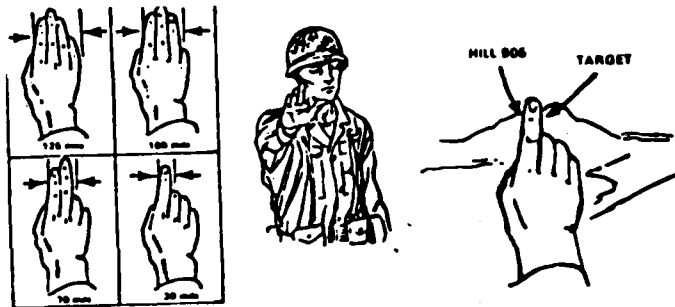

Figure 4-9. Illustrating a "positioning" response (11C, p. 2-IV-A-1.2).

Often, survival tasks involve difficult discrimination, such as the immersion foot shown in Figure 4-10. Such discriminations require much higher fidelity in drawings than other illustrations of procedures, and comparative illustrations are often useful.

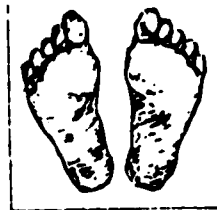

Figure 1. Immersion foot.

Figure 4-10. Difficult discrimination (11C, p. 2-I-A-8.2)

An Example

Consider the example "locate mines by probing" shown on the following page. The telegraphic style, as well as the illustration, is to allow for using the task summary for scoring also, either by a trainer or another soldier. Perhaps the procedure should also be described in sentences on the facing page. The narrative should be divided into steps that are numbered to correspond with the picture-guide so that the soldier can correlate the two descriptions. This may be an apparent exception to the rule against specifying responses in both text and illustrations. However, in this case, the picture-guide version is a complete set of instructions with its own story line, rather than an adjunct branch that later joins the main line of instruction.

LOCATE MINES BY PROBING

CONDITIONS: From starting line, to position shown below.

STANDARD: All actions marked "°." Time, 4 minutes.

PROCEDURE:

1. PREPARATION

- ° Remove helmet, web gear
- ° Remove dogtags, jewelry
- ° Roll up sleeves

2. GETTING INTO POSITION

- ° Look, feel upward and ahead for tripwires, pressure prongs
- ° Move on hands and knees or crawl

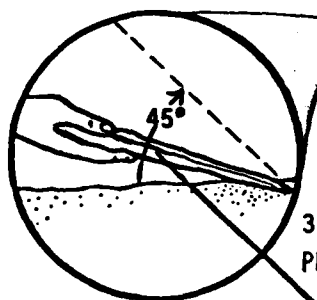

3. PROBING

- ° Palm up
- ° Less than 45°
- ° Probe GENTLY
- ° Every 2 inches or less

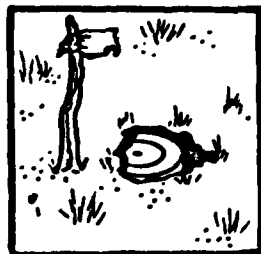

4. MINE LOCATED

- ° Remove enough dirt to see that it is a mine
- ° Mark it (you'll be given materials)

Notice that a "kernel" illustration seemed sufficient in this instance for the first three steps. There was no need to illustrate the original configuration. Perhaps the second step (getting into position) might have been illustrated because that is a somewhat unfamiliar operation, and the soldier might forget it. That may be considered borderline, and therefore optional.

Note how the "conditions" statement described that situation by first acknowledging the starting position, but also by referring to the "kernel" illustration. The statement of conditions may be deficient in assuming that the soldier knows how to decide when to probe for mines, and when to destroy them in place or use some other procedure. A developer should make a note on the Task Analysis Worksheet under "knowledges and skills" to check whether that decision has been covered in previous tasks. It would be desirable in any case to add something in the conditions statement about how a soldier would decide to probe for mines. The revised statement might read:

"Conditions: You suspect that there may be antipersonnel mines in an area you must cross, because of freshly-dug earth, other mines in the general area, or some other sign. You are not sure whether there are magnetic mines in the area. Therefore, you decide to probe for possible mines. In training, you will move from a starting line to the position shown below."

It is always desirable for the conditions statement to tell the soldier the circumstances under which he would decide to do the task, whenever it might not be obvious. In field operations, you should be particularly alert for conditions statements that do not say when the procedure is used.

Notice that the procedure is organized in four numbered steps. That is critical for this kind of task because so many of the items might be forgotten without the soldier discovering it during practice. Diagramming the task structure is a critical step in such organization of instructions.

The trainer's method of using such instructions should be specified somewhere in the Soldier's Manual. The trainer should be told about using the picture-guide form for testing, either by himself or another soldier. The trainer also needs to know that such tasks are easily forgotten because so many of the standards involve apparently arbitrary details (e.g., "palm up"), and because there is nothing in the mechanical arrangement during practice that would inform the soldier when he forgot something. The trainer should also be reminded that the soldier can practice the task without the equipment, using a pencil or something like that to simulate the probing stick. You should suggest having the soldier "talk through" the procedure as he practices, using his own words to help him remember, and to demonstrate to the scorer that he remembered. Preferably, those practices should be suggested in a general section for trainers in front of a group of similar tasks. But if you cannot arrange that, draft a "notes for trainers" section at the end of your task summary. If your suggestions are subsequently included in a more general section, those items can be deleted from the task summary.

Related to Other Kinds of Tasks

Most basic battlefield techniques are not classified as field operations because they are considered decision-making rather than a procedure. They involve choice: selecting a

position, choosing the best path to follow, or reacting to flares (depending upon the circumstances).

Field operations do include critical parts of land navigation tasks. For instance, map reading involves orienting a map with respect to the real terrain, and that is considered a field operation. Most of the steps in map reading would be classified as a procedure with data, but it is important for training not to neglect the steps that we classify as field operations. Similarly, many other procedures with data involve some steps that should be instructed as "field operations."

MAINTENANCE

Maintenance has traditionally been considered a separate task category because it involves a particular kind of function and activities performed in separate situations. In addition, maintenance tasks may be distinguished on the basis of the kinds of training that are appropriate, as are the other task categories.

Preventive Maintenance

Preventive maintenance is performed before a fault appears, as its name implies. This is usually the finest classification for a task summary. Some examples are: maintain protective mask and accessories, maintain an M203 grenade launcher and ammunition, maintain a caliber .45 pistol and ammunition, maintain 81mm mortar and equipment, perform loader prepare-to-fire checks, perform before-, during-, and after-operation maintenance checks and services on an M60 series tank, prepare 81mm mortar ammunition for firing. Our classification system distinguishes three kinds of subtasks because distinctly different considerations are involved in developing instructions.

Inspect and adjust. Inspection activities involve responses that are rather difficult to specify from the standpoint of an objective observer. There is a comparable difficulty in testing. Often the Skill Component questions in the SQT employ the "DO-NOT DO" format for this kind of skill. What soldier, for instance, is going to say that a person should not look for mildew? One way of getting around the problem in training and testing is to require the soldier to "talk through" the procedure out loud as he performs the task, while the scorer checks the criterion points that he mentions, or fails to mention. For this, the equipment may be simulated by a mockup, or even with pictures. You should suggest these techniques somewhere in your "notes to the trainer" if you are developing instructions for this kind of task. But you may also consider the priority given the task, because it may not be worth special effort to train.

If the inspection involves difficult perceptual discrimination (e.g., how much wear is acceptable), then there may be a need for fidelity in the pictures, and perhaps some discrimination training. For instance, pictures (or samples) might show how much wear is just barely acceptable. But generally, such thresholds are not critical anyway, so there is much latitude for individual judgment.

Adjustments are generally matters of mechanical changes, so the task instructions should employ techniques like those for "zero and adjust." If the "adjustment involves turning in the item, be specific about who should get it, and what forms to fill out, if any.

Lubricate, treat surface. Maintenance commonly involves some treatment of the surface, such as cleaning, sanding, lubricating, or painting. Often there is an underlying scale of harshness of treatment; if so, that should be apparent in your wording of instructions. Usually you will specify particular solutions or treatments that should be used, and perhaps some that should be avoided. Sometimes you may want to show the container or applicator in an illustration, if that will help the soldier find it. But do not use such illustrations merely as adjuncts.

Often you should give a locational illustration, using techniques like those for inspection. The locational view may be combined with the one for inspection, unless that results in excessive clutter. If you use combined illustrations, the two functions should be distinguished by some format technique (e.g., underlining of surface treatments).

Rarely will you need to picture the overt responses in surface treatments. They are almost always common practices.

Often maintenance involves lubrication other than surface treatment. In the Army, such lubrication is associated with related activities, and instructed by a special kind of job aid called a "lube order." When a soldier learns how to use lube orders, what he is learning is not so much the procedure on the specific piece of equipment, but rather how to "decode" the symbols and format of lube orders generally. We classify such tasks as a kind of communication skill; specifically, using job aids. When we discuss that category in Chapter 5, we will analyze an example of instructions for using lube orders. However, using lube orders may involve some responses that must be taught as "subroutines," which usually would be classified as some kind of procedure with equipment. The easiest way to determine the need for such subroutines is to begin by developing instructions for using lube orders in general, as specified in Chapter 5. Then if novices cannot perform certain responses from the lube order and the instructions, then subroutines should be developed for those responses.

Assembly, disassembly. Assembly and disassembly should ideally be illustrated with a detailed series of illustrations showing the action evolving through numerous stages (an example is shown in Figure 4-11). The pictures should show the weapon and hands from a subjective viewpoint. Responses should be specified briefly in connected notes over the picture. Other text should be minimal, or completely eliminated. The pictures should be clustered to imply an "execute" command at the end of the cluster, so that the soldier knows when to act.

Often that ideal should be compromised. If the device is very simple, an exploded view may be sufficient, especially if experienced mechanics are to perform the task. An intermediate level of detail is shown in the Air Force Job Aids (Figure 4-12), which appears to be sufficient for the task, considering that it is to be performed by experienced mechanics. Another consideration is whether the task is to be performed at remote locations, without anyone around who is experienced and could help occasionally if the soldier has trouble with some steps. Before investing effort in an extremely detailed series of illustrations, you should determine whether your organization will support that development, and implement the results.

Assembly and disassembly differ from most other tasks in that they involve a high degree of intrinsic feedback. That is to say, if the soldier makes a mistake, he will soon know about it because of the mechanical properties of the weapon. However, it may be

3. MAINSPRING HOUSING AND GRIP SAFETY

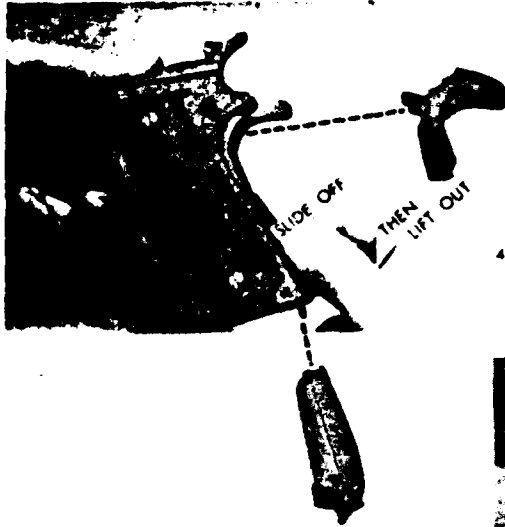

4. SEAR SPRING

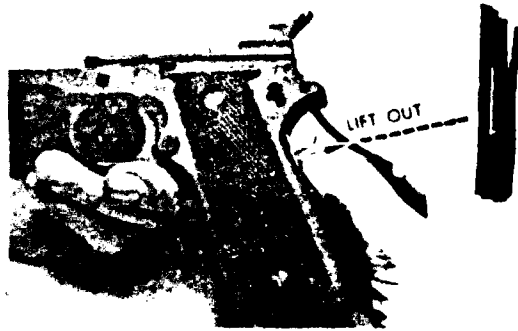

5. HAMMER, HAMMER STRUT, AND PINS

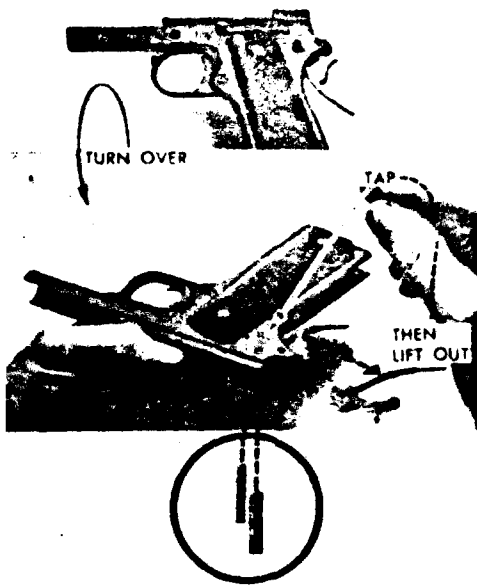

6. SEAR AND DISCONNECTOR

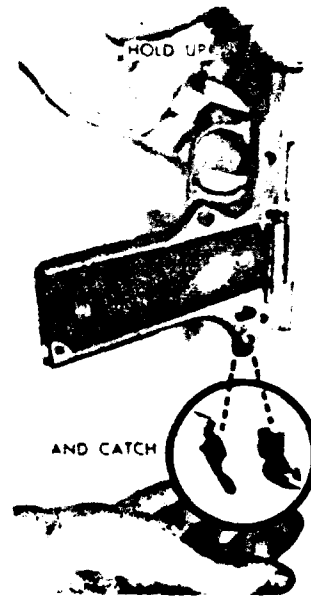

Figure 4(2). Disassembly of receiver group.

Figure 4-11. "Picture-guide" technique in disassembly.

T.O. 1C-141A-2-4JG-4

REMOVE AND INSTALL FUEL PUMP

Install Fuel Pump On Engine:

CAUTION

Do not use any lubricant, other than engine oil on mating splines (1). Use of grease can clog oil feed holes in engine gearbox and restrict oil flow during engine operation.

6. Lubricate fuel pump mating splines (1) with engine oil, MIL-L-7808.

CAUTION

Do not allow weight of fuel pump to rest on shaft splines (1) during installation. Undue weight can impose stress on gearbox shaft oil seal, causing seal damage.

7. Working with assistant, raise fuel pump into position. Align pinholes (4) in pump with pins (3) on gearbox mounting flange (2).

8. Install fuel pump on gearbox mounting flange (2).

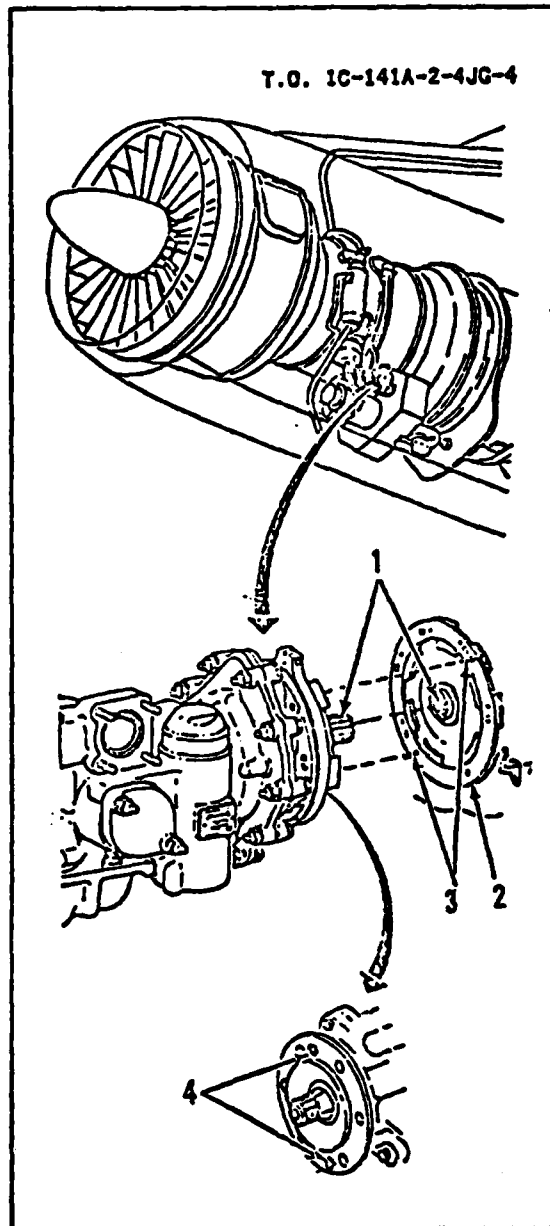

Figure 4-12. Example of job performance aid format.*

*Reproduced from R. C. Johnson, Technical order useability, in T. G. Sticht & D. W. Zapf (eds.), Reading and readability research in the armed services (Final Report FR-WD-CA-76-4), Alexandria, Virginia: Human Resources Research Organization, September 1976.

helpful to be told what can be done to correct the mistake. The weapon also gives the soldier a rich sense of the "feel" of the weapon, which is very important to learning the task. The weapons are also usually available for practice, so there is little purpose in photographic simulation, or in "talking through" the tasks while practicing. Note that that is quite different from "inspection" and some of the other kinds of tasks we have considered. You should compare such practice conditions for different tasks in notes to trainers. But be brief, and discuss it on the most specific level you can without being repetitive.

Corrective Maintenance

Corrective maintenance consists of two kinds of activities: diagnosis and repair. Even though they may be done by the same person, and sometimes in the same time period, they are distinguished because they involve quite different sorts of activities.

Diagnosis. Diagnosis of faults is commonly called "troubleshooting," which seems to imply a searching kind of behavior without anything approximating a fixed sequence. But the method is usually proceduralized, in which case it may be called "Fault Isolation Procedures" (FIP), which are your concern if you are writing a task summary.

The main consideration in writing task summaries for FIP is to maintain continuity of performance from fault detection to diagnosis of the fault, while providing enough realism for the soldier to visualize critical aspects of his job environment. Maintaining continuity in a task summary is made difficult by: (1) several manuals and items of equipment are likely to be involved in any problem, (2) the equipment may be unavailable for practice because of expense and size, and (3) an FIP is likely to be time consuming. Those considerations make it imperative in a task summary to simulate the equipment with pictures. That is feasible because (1) much of the critical activity is "mental" (i.e., covert) and (2) very few manipulatory responses have to be learned.

The need for effective illustrations of the equipment is particularly important for novices. Experienced technicians may be able to learn from words alone if their experience is sufficient to allow them to "visualize" the equipment. But novices with only a few hours (or less) on the equipment cannot make the right "connections" between lecture and practical exercises.

In some ways, learning FIP is learning to use a job aid, including symbols and format of the system of tables and diagrams. A soldier is likely to generalize many skills from one procedure to another. Therefore, there is no need to have a task summary for every FIP.

FIP also involves use of test equipment, which can be instructed as a subroutine somewhat removed from the practice of FIP. However, practice with test equipment should involve the elements commonly seen in FIP.

Test equipment. Two kinds of test equipment will be discussed: multimeters and oscilloscopes. A multimeter represents the simplest, most basic kinds of test equipment. The oscilloscope involves many added complexities, both in its functioning and in the task environments in which it is employed.

The TS-352 A/U Multimeter. This task is not a matter of the specific equipment tested, but a subroutine for use on many kinds of equipment. With the multimeter, it is important not to restrict the analysis to physical aspects of the test set, because the essential elements are not physical components, but operations to be performed.

Consider the first instructional instance--measuring voltage of a 12 volt battery (Figure 4-13). One essential element that is almost always overlooked is selecting the right scale to read from in step 6: the "5" row corresponding to the "50 volt" jack. The novice has no conceivable way of knowing that one should look at the high end of the DC scales and match the digits to select the middle row. Other mental elements often overlooked are: multiplying to get final answer from the scale, and what knobs and jacks to ignore.

Oscilloscope. There are two important ways in which the oscilloscope (AN/USM 218A) differs from the multimeter: (1) its complexity and (2) the criticality of certain specialized concepts for learning the procedures.

The complexity makes it essential that the illustration, descriptive tables, and procedural tables be organized for use, to reduce steps. But TM 11-6625-1703-15 begins with 23 pages describing the controls, and then 17 pages of procedural tables. At each step the procedural tables refer to controls by name, so the novice has to search another table to find the corresponding key, then search the illustration to find the control picture, and then match that with the equipment. No "foldout" illustrations or tables are provided, so a person has to flip back and forth repeatedly. The text should be keyed to the illustrations in these steps, either directly or with a minimum of coding.

The oscilloscope also involves specialized concepts that are critical to adjusting the set (e.g., the electronic trigger). Without these concepts, on many adjustments the operator does not know what pattern to adjust for. Thus, the screen display makes no sense without the concepts. The concepts sharply reduce the amount of information the person must process in making the adjustments. Of course, criticality of these concepts should be confirmed experimentally. Yet it should not be assumed that using an oscilloscope is a simple, straightforward procedure like using a multimeter.

Repair. After a fault has been diagnosed, the equipment may be repaired by replacing components, or by fixing the old components. Replacement is by far the more common kind of task in the Army because fixing the old parts is generally authorized only at higher echelons of maintenance.

The most important kind of illustration for replacement is the locational view. Often the illustrations involve multi-stage locational views, as exemplified by Figure 4-12. Since the mechanics are experienced and the responses usually are common practices (e.g., removing a bolt), there is seldom a need to illustrate the overt responses. Sometimes a "cutaway" illustration is used, which often serves also as a locational view.

Fixing the old components involves focusing on some small aspect of the system, so there is much less need for locational views than in replacement. There often is need for illustrating the overt responses, and for various kinds of illustrations for "understanding," depending upon the specifics of the repair being made.

MEASURE VOLTAGE WITH TS-352/U MULTIMETER

Conditions:

1. Measure low DC voltage
2. Measure AC voltage, 100-1000 volts
3. Measure DC voltage, 1000-5000 volts

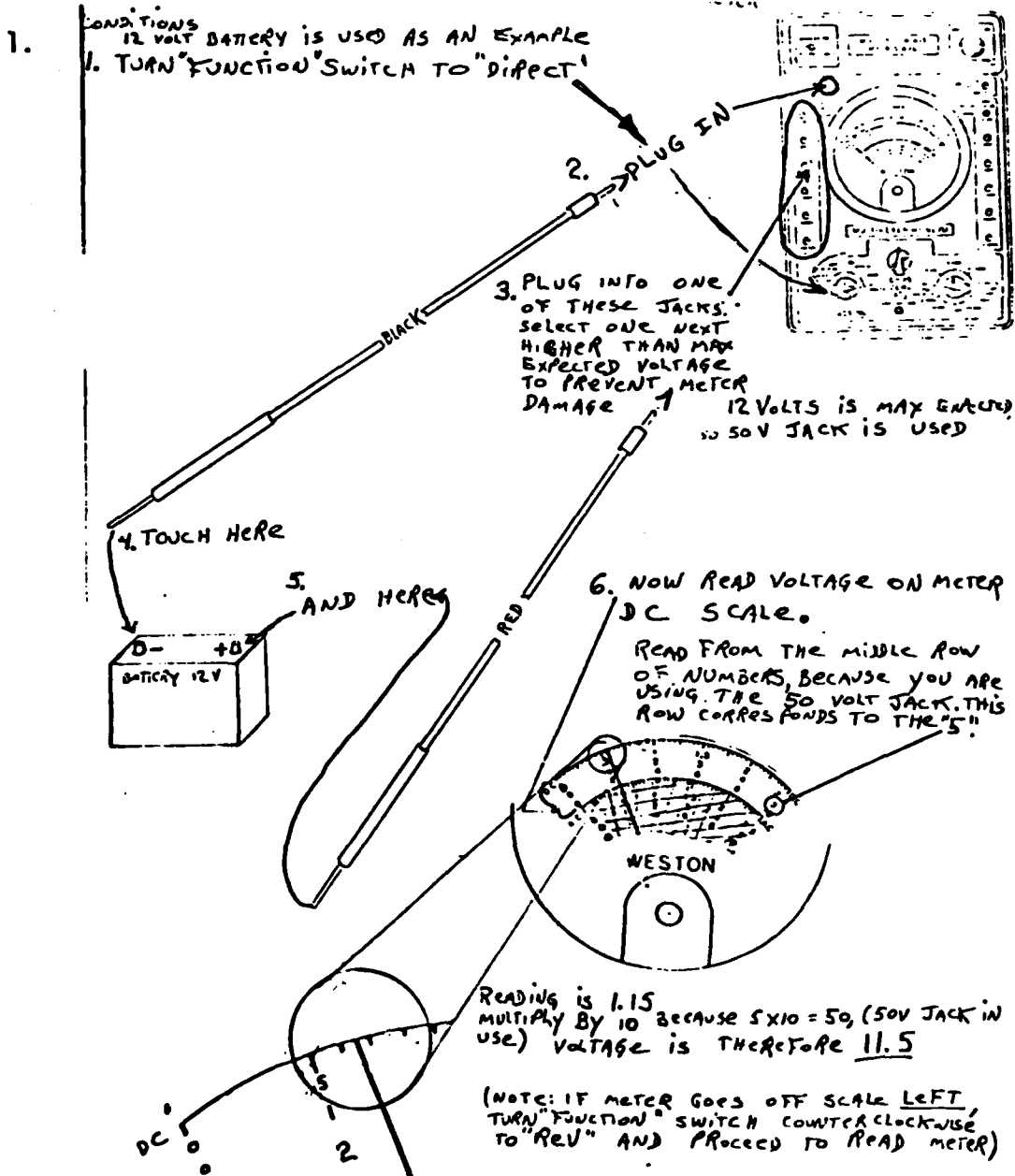

Figure 4-13. Measuring voltage, 12 volt battery.

SECTION 3: PROCEDURES WITH DATA

This section is a discussion of the circumstances that define different kinds of procedures with data, as they affect programming of task instructions. Take particular care in diagramming the task structure. Those diagrams tend to be more difficult when a procedure involves data, because of greater task complexity, but for the same reason the payoff is likely to be greater also. If you have problems determining how to perform the task, you should try diagramming early as a means of clarifying the task. You may be able to infer the task from the diagram, or at least find penetrating questions to ask in your search for information.

SALIENT CHARACTERISTICS

The most important thing to remember about procedures with data is the great freedom you have in using illustrations. All of the action can be illustrated as paperwork. You do not have to go out and take pictures of the equipment, involving all of the camera angle and closeups. This freedom allows you to picture all of the important responses, as writing. No other kind of overt response is so easy to picture. The important displays are printed, usually published materials. Procedures with data are performed in a paper world.

Another important consideration is complexity, which is apt to be much greater for this kind of task. This especially affects the statement of "conditions," which is not apt to involve the physical circumstances of the job. Instead, you should state conditions in terms of how the soldier would decide to do the particular task, rather than some other. This requires your knowing how the task is related to some other tasks, and such "broader knowledge" is most often lacking in this kind of task summary.

Because of complexity, this kind of task summary will also require greater attention to prerequisites. The main consideration here is that you should be careful to note the specialized skills that you are assuming in your draft. The SM should instruct all required responses somewhere, but not over and over again in every task summary where they are used. For instance, jobs that involve entries on DA standard forms are apt to use the same entries in numerous tasks. You may need to coordinate with writers of other task summaries to decide where such common operations will be instructed, and this will be discussed further in Chapter 5.

BRANCHING INSTRUCTIONS

Generally, you will only need to read the subsection for the kind of task summary you're writing: Graphics, Composition, Calculation (these are defined below). Within the subsection you should focus on the most particular kind of task, in order to incorporate those suggestions in your draft. Then skip to the end of this section, to the note on "insuring coverage."

GRAPHICS

Graphics involve scale drawings of physical space. Usually that is a map or some other plot representing the earth's surface. It logically includes other kinds of drawings, such as mechanical plan views, but those are not our primary interest here. It does not include schematics, because they are not to scale, but rather are designed primarily to show logical rather than physical space.

Read Plot

The most common military task of this sort is map reading. First, note that practical map reading also involves orienting the map with the earth, which was discussed earlier in "field operations."

The fundamentals of this kind of skill may be illustrated with real plots, overprinted with lines, arrows and words specifying the response. Many of the essential operations are scan patterns, so those need to be drawn. This technique is shown in the example of calculation tasks using tables (see example below). In using the overprint to specify responses, keep it distinct from the plot itself by using distinctive lettering and lines (e.g., italics and heavy lines).

Keep the scale of plot rather large at first, so that the basic ideas may be unambiguous. Later, finer discriminations may be required, but there is always a danger of setting standards too high in this respect, especially if reproduction blurs the plot, thus inadvertently increasing standards. For example, if map problems on the SQT require difficult discriminations, and the maps are blurred in printing, and the soldier is nervous and pressed for time, he may score NO-GO even though he can perform the task well enough for practical purposes.

Draw Plot

A common military task of this sort is using the M16 plotting board to plot fire missions for mortars. There are four kinds of plotting (e.g., observed chart, pivot point) so the first thing to explain is the conditions under which each is used. That should be a short subroutine for decision-making, as described in Chapter 5. The important rule in decision-making is to lay out the basic decision first in the simplest terms, and then add whatever qualifications are needed.

Using the M16 plotting board involves alining the azimuth disk, which should be illustrated as a mechanical alinement. The task also involves using firing tables and making entries in the computer's record, which may be illustrated with the techniques discussed below under "Make Simple Entries." Whatever the technique, be sure to maintain one continuous story line in your task summary.

COMPOSITION

Tasks of this sort involve production of some kind of written product.

Make Simple Entries

This kind of task involves filling out standard forms in which each entry involves only common practices, such as name, date, nomenclature, or symbol. This qualification is to exclude computation forms, which require elaborate instructions for each step. (Those are covered under "Calculation" below.)

An example. Consider the instructions on filling out DA Form 2408-14 contained in TM 38-750 and reproduced on the following pages. Then on the following page, read the revision. This version involved successive application of three logical criteria: relevance, directness, and sufficiency.

Relevance. Relevance is a matter of getting specific information on each response (i.e., entry). As you diagram the task structure, try to determine what input information is task-relevant.

As you begin to divide the task, determine whether the form involves different kinds of entries for different people; if so, separate sets of instructions are desirable for specificity. In this case, aircraft maintenance involved different conventions for entries, and is performed by different kinds of specialists, so they were referred to a separate set of instructions adapted to their specific needs.

Directness. Directness is minimizing the number of steps required of the reader. Sort the information according to which entry is involved, so that instructions may be made response-specific. Almost all of the information could be sorted that way on this form. When the instructions are sorted into sections that are response-specific, the reader can make his response immediately after reading each section. This is analogous to the "execute" command in some computer-based systems.

Later, as you begin writing and illustrating each step, picture the form and specify each response in connected notation. The picture of the form with written entries should be integrated with the text, rather than shown in a separate figure. It helps if the form is reduced by one-third and cut into sections.

Beware of suggesting any detours. For instance, in the original, paragraph C(1) says "Entries will be made in accordance with paragraph 1-7a(a)." Finding that instruction is tedious, and it merely says what kind of pen or pencil is allowed. When a reference is not used by most readers, much time is saved by stating the purpose of the reference (e.g., "use pen or pencil as authorized in paragraph..."). Another temporary roadblock was page 4-50.1, which looked like the end of that section. When a change does not fill a page, there should be a prominent note saying "continued." Another distraction was repeated reference to "DA Form 2408-14" instead of "this form." Whenever directions are for a particular form, say "this form" rather than giving the complete title. That saves the soldier the bother of checking every letter and digit. These may seem to be trivial annoyances, but when compounded they may become a substantial problem.

Sufficiency. In writing each connected notation, try to specify the operations in terms that are sufficient to determine the response. Simply giving some relevant information may not be enough. Remember that the example you use is only one instance. Your instructions should cover all possible circumstances, or at least the common situations.

the status symbol in block 16.

(c) When an accessory or item of equipment is due for replacement, the following entries will be made on DA Form 2408-13.

1. *Block 16.* Enter the appropriate status symbol.

2. *Block 17.* Enter the nomenclature and type of accessory or item of equipment that is due replacement.

3. *Block 18.* When an accessory or item of equipment which has an established replacement period is replaced for expiration of time, failure, or other reason, enter a remark to this effect. Include the serial number of the newly installed accessory.

4. *Block 19.* Enter the signature of the mechanic who accomplished the work.

5. *Concurrent entries.* Appropriate entries will be made on other pertinent DA Forms concurrently.

d. Disposition.

(1) The completed DA Form 2408-13 will be removed at the end of the day's operation and forwarded to the aircraft maintenance office of the activity maintaining the aircraft. Those forms completed while the aircraft is on a cross country flight will remain in the log book until the aircraft returns to home station. When the aircraft is detached, these completed forms will be turned in to the designated responsible maintenance or operations element and returned to the maintenance office of the aircraft owning unit upon completion of the detachment. Those forms completed while the aircraft is undergoing extensive inspection or maintenance will remain with the aircraft until all work is completed, at which time they will be forwarded to the maintenance office.

(2) DA Forms 2408-13 received in the maintenance office, will be carefully checked against the previous DA Forms 2408-13 to insure that aircraft time and other entries have been correctly entered.

(3) A DA Form 2408-13 reflecting current aircraft status will remain in the logbook of aircraft in administrative storage.

(4) DA Forms 2408-13 will be maintained for six months following the date of last entry and then destroyed.

4-13. DA Form 2408-14 (Uncorrected Fault Record)

(figs. 4-30 and 4-31)

a. Purpose. This form provides a record of uncorrected faults on Army equipment.

b. Use.

(1) For equipment (except aircraft) identified by an "X" in the DA Form 2408-14 column of appendix E.

(a) Serves as a record of uncorrected faults and deferred maintenance actions shown by a status symbol (X), dash (-) and diagonal (/) (para 4-2c(1)). The deferred maintenance actions on DA Form 2404 that has not been accomplished will be transcribed to DA Form 2408-14.

(b) When the commanding officer or the designated representative authorizes the use of an item of equipment and assigns a (X) status symbol, he will sign his last name and first initial in column e, DA Form 2408-14.

(c) Do not record uncorrected faults, status symbol X which cause equipment to be inoperable and are scheduled on DA Form 2404 or 2407 for repair at organizational or support maintenance.

(2) For aircraft as listed in appendix E.

(a) This form is used to record uncorrected faults, deferred maintenance, and the reason therefore. DA Form 2408-14 is used with DA Form 2408-13 and DA Form 2404 (if used as an inspection worksheet (except PMD)).

(b) The commanding officer or the designated representative will determine when a fault will be transcribed to DA Form 2408-14. However, faults bearing the status symbol of a red X, or a red (X), will not be entered on this form. Red dash (-) status symbols may be entered on this form when it is necessary to defer a normal DAMWO application past its normal expiration date. When a red dash (-) status symbol is entered on this form, it will necessitate a red dash (-) status symbol in blocks 7 and 16 of DA Form 2408-13, and carry the following general reference in block 17 of DA Form 2408-13, "Overdue DAMWO."

c. Preparation.

(1) *Entries.* Entries will be made in accordance with paragraph 1-7a(2).

(2) *Block 1.* Enter the nomenclature of the item, e.g., TRK CGO, HEL UTIL.

(3) *Block 2.* Enter the model number. For rail equipment, leave blank.

(4) *Block 3.* Enter the serial number. For commercial design vehicles, enter the USA registration number in lieu of the serial number. For floating equipment (ECC LB and LM), enter the Dept of Army hull number. If item does not have serial number, enter "none."

(5) *Column a.* Enter the status symbol. For aircraft, symbol will be in red. Status symbols, once entered, will not be erased or changed, even if entered in error. If an erroneous entry has been made, draw a single line through the entry, enter the correct data on the next open line.

(6) *Column b. Enter the fault.*

(a) *Equipment other than aircraft. Entries will be transcribed verbatim from column c, DA Form 2404 (para 3-4).*

(b) *For aircraft. Entries with exception of the*

1. NOMENCLATURE		2. MODEL	3. SERIAL NUMBER	
TRK UTIL		M151A1C	2E3681	
STATUS SYMBOL	FAULT	REASON FOR DELAY	DATE (From DA Form 2408 or 2408-13)	ENTRY APPROVED (Signature)
✓	TAIL LIGHT LENS CRACKED	GRSS 7148 T220.00.752-6020	28 MAY 77	B. Buis
B	NEEDS SPOT PAINT - R & L SIDE BODY	SCHEDULED FOR NEXT PM SERVICE	3 JUN 77	B. Buis
✓	CRACKED WINDSHIELD - RIGHT CENTER	SCHEDULED FOR NEXT W/SHOP SERV REQUEST	10 JUN 77	B. Buis
⊗	FRT WHL DRIVE INOPERATIVE	WOM A9216-003 BACKLOG	12 JUN 77	B. Buis
/				
DA FORM 2408-14, 1 JAN 64		GPO 1964 O-751-343		UNCORRECTED FAULT RECORD (FM 38-750)

Figure 4-50. DA Form 2408-14 (Uncorrected fault record - vehicle) (Example).

1. NOMENCLATURE		2. MODEL	3. SERIAL NUMBER	
AIRCRAFT UTIL		U-8G	61-38761	
STATUS SYMBOL	FAULT	REASON FOR DELAY	DATE (From DA Form 2406 or 2408-13)	DATE (To DA Form 2408-13 or 2409-13)
✓	3 APR 76 SWITCH WING DEICING INOPERATIVE.	6102-0022 5930-00-653-5969	12 APR 76	16 APR 76
✓	3 APR 76 CP MIKE BUTTON MISSING	6103-0026 5930-00-323-1574	13 APR 76	
✓	4 APR 76 RIGHT ENG COWLING CRACKED AT LATCH	6104-0051 1560-00-770-8138	14 APR 76	16 APR 76
✓	8 APR 76 ONE INCH CRACK LOWER RIGHT FIREWALL	WO 925648 AWAITING SHOP	26 APR 76	
UNCORRECTED FAULT RECORD (TM 38-750)				

Figure 4-51. DA Form 2408-14 (Uncorrected fault record - aircraft) (Example).

supply request number (or work request number when applicable), will be transcribed verbatim from block 17, DA Form 2408-13, preceded by the date on which the fault was discovered. Any supply request or work request number associated with the fault described in block 17, DA Form 2408-13, will be segregated from the fault and entered in column c, as prescribed in (7) below.

(c) *Aircraft inspections.* When the DA Form 2404 is used for aircraft intermediate or periodic inspections, uncorrected faults recorded in column c of this form will be transcribed verbatim (except as outlined in b(2)(b) above).

(7) *Column c.* Enter a short statement indicating the reason for delay of corrective action in this block. In instances where repair is delayed or deferred due to shop backlog, enter the work request number. Where a replacement part is the reason for delay, the supply request number (or in case of QSS or SSSC items, the term QSS or SSSC, and the Julian date that the item was requested and found to be at zero balance) and NSN or part number, will be entered (figs. 4-30 and 4-31).

(8) *Column d.* When transcribing any fault to DA Form 2408-14, the date the entry was transcribed will be entered in this block.

(9) *Column e.* Each entry recorded on the DA Form 2408-14 will be approved by the commanding officer or his designated representative who will place his signature in this block.

(10) *Column f.*

(a) Enter the date the fault was corrected. The individual correcting the fault will enter his last name initial over the status symbol in column a.

(b) For aircraft enter the date the fault was transcribed to the current DA Form 2408-13 or to the DA Form 2404 prepared for the conduct of a specific aircraft maintenance inspection. The symbol block will not be initialed until corrective action has been taken.

d. *Disposition.* Completed DA Form 2408-14 will be retained for a period of six months after last entry is made in column f and then destroyed.

4-14. Historical Record for Aircraft and Overprinted for Aircraft Turbine Engines (DA Form 2408-15)

(figs. 4-32 through 4-34)

a. *Purpose.* This form provides historical data pertinent to the aircraft through its life and provides a semi-permanent historical record for aircraft turbine engines to include progressive quantitative results of aircraft turbine engine analysis check (TEAC) for turbine engine. For aircraft turbine engines, this form will be overprinted on one side with column headings as shown in figure 4-33, and provide a progressive record of results of required TEAC and

TASK 143: Fill Out DA Form 2408-14

Conditions: In filling out DA Form 2404 there was a fault that could not be corrected immediately, but the equipment was still operable. (This page is for equipment other than aircraft. Aircraft faults are discussed on the following page.)

Standard: Check correctness of entries on all points specified below.

Procedure:

1. Identification of vehicle

Use nomenclature and model numbers from TM 38-750, Appendix E

From vehicle inspection log, or from nomenclature plate on vehicle

1 NOMENCLATURE TRK UTIL	2 MODEL M151A1C	3 SERIAL NUMBER 2E3681
----------------------------	--------------------	---------------------------

2. Entries

Use one of the following:

- ⊗ = deferred maintenance on action, equipment still operable
- / = deficiency that only degrades efficiency
- = potentially dangerous

defined in TM 38-750 para 4-2 c(1)

Do not use "x" because that means the equipment is inoperable, and you should use DA Form 2407.

Do not erase status symbol if it is an error. Instead, draw a line through the whole entry and start again on the next line.

Copy verbatim from 2404, column c.

Date of entry

Give reason for delay and information about action taken.

Signature of commanding officer or designated representative

STATUS SYMBOL	FAULT	REASON FOR DELAY	DATE (From DA Form 2408-14)	ENTRY APPROVED (Signature)	DATE (To DA Form 2408-14)
/	TAIL LIGHT LENS CRACKED	QSS 7148 D220-00-752-6020	28 APR 77	B. Bird	
/	NEEDS SPRT PAINT - R&L SIDE BODY	SCHEDULED FOR NEXT PM SERVICE	3 JUN 77	B. Bird	10 JUN 77
/	CRACKED WINDSHIELD - RIGHT CENTER	SCHEDULED FOR NEXT M/SHP CARV REQUEST	10 JUN 77	B. Bird	
⊗	FRT WHL DRIVE INOPERATIVE	WOP#9216-003 CRACKLED	12 JUN 77	B. Bird	

a. NSN (National Stock Number)
c. QSS or SSSC

b. Julian date that part was requested
d. Work order number (in case of backlog)

3. Fault Corrected

Then the person who does it writes the date in the last column and his last name initial over the status symbol.

M

10 JUN 77

4. Disposition: Six months after the last fault is corrected, this form may be discarded.

A general problem in standard forms is whether one can leave an entry blank, and under what conditions. Instructions should always indicate this, either explicitly or implicitly.

When only a few responses are acceptable, your instructions should say to "use one of the following" and then list the responses, with a brief definition of when to use each. The soldier's task is to select the best match for his case, rather than considering unspecified alternatives, which is quite a different process. If the list of responses is long, there may be a need to refer to another source. For instance, the revision referred the soldier to Appendix E of TM 38-750 to get the nomenclature and model numbers that were acceptable entries. The soldier could make a list of the ones he used often. The revision also used the "list" technique to give the three acceptable status symbols. In that case, the list was so short that there was no need to refer the soldier elsewhere. However, this list also included short definitions of the status symbols, and referred the soldier to TM 38-750 for the legalistic definitions. That kind of compromise is often useful for specifying responses; giving no definition would be insufficient, but a complete definition would be too long and difficult to understand.

Another kind of instruction is to "copy verbatim," as opposed to "describe in your own words." Another response class involves common kinds of information, such as dates or signatures; for such responses, it is especially important to specify the response class in a connected notation (e.g., whose signature: "commanding officer or his designated representative").

The conditions statement described the situation which led the soldier to fill out the form. When a system is complex, like TAMMS, such conditions should be determined for the whole system by developing a flow diagram connecting all of the forms.

Compromises. Perhaps specifying every response in connected notation is not needed on all forms. But most of the burden of proof should lie with those who want to be less thorough. Sometimes survey information will indicate severity of problems, and perhaps identify some of them. But bad forms and incomprehensible instructions may result in a generally confused situation. Also, people have not learned to expect effective forms and instructions. Often the shortcomings are patched over by word-of-mouth instructions, which tend to be very inefficient.

The forms themselves. The best way to approach problems involving forms is to revise the whole system, including the forms, using kinds of analysis like the one described above. You may have an opportunity to revise the forms yourself, or to recommend such revision. That is beyond the scope of this publication, but such an approach is discussed elsewhere.¹

¹E. E. Miller. Designing printed instructional materials: Content and format (RP-WD-TX-75-4). Alexandria, Virginia: Human Resources Research Organization, October 1975.

Follow Format

Following format hardly seems likely to win any battles. It might occasionally avoid some confusions. At best, if it is instructed efficiently, resources might be shifted to matters of higher priority. After all, tremendous amounts of time and money are spent on paperwork, and if some of the operations can be radically simplified, substantial savings could result. An example is preparing an indorsement, which is an extremely common military task since all Army letters are forwarded and answered by indorsement.

However, our main interest in indorsements is not as a format task. The techniques for using illustrations are applicable to most procedures with data, especially when written responses are not constrained by a standard form.

Prepare a draft indorsement. First, compare the original SM instructions (starting on the next page) with the revision that follows it. This example has many principles in common with directions for standard forms. Each reference is specified in a note. Those definitions were all given on the first indorsement, insofar as possible. The reason for defining all elements on the first indorsement is so that the reader does not have to look at later pages, and collate the requirements. The requirements on subsequent pages were given "by exception only" so that the reader would not have to reconsider the basics.

Note also that the example was carefully selected to include "occasional" elements: the suspense date and inclosures. A common mistake is to include numerous random examples, but miss some critical elements.

The note related to "1 incl, nc" defined all the common alternatives, including when to leave it blank. This important rule is almost universally neglected. How else is a person supposed to know that "nc" is the approval code for "no change of enclosure?" This notation also referred the reader to the basic manual for the uncommon or involved cases: when some inclosures are deleted, and later inclosures have to be renumbered. Perhaps it would have been better to cover all possible cases, but the principles remain: (1) cover all alternatives if space allows, (2) otherwise, refer to another source. Extra words were not so serious a consideration as in some other situations because the reader only has to read until he finds the entry he needs. Also, note that the reader would refer to AR 340-15 only if the particular case is not covered by the common entries.

Sometimes the example is chosen so that the content is relevant to the instruction. In this case, the letters and indorsements could discuss the characteristics of military indorsements. That is a clever idea, but it has a serious drawback: the reader is apt to infer that he should study all of the content in addition to the connected notations. That is likely to more than double the time needed to learn the procedure.

Note also that one continuous example was used throughout. That allows the reader to check which elements should be continued, and which should be changed. A very common mistake in instruction is to skip between little chunks of various examples in an attempt to include all learning elements, thereby losing the thread of related elements. It is far better to work completely through one minimal instance involving all regular and occasional elements.

This kind of analysis may seem extremely laborious, and it is. The results may not be worth the effort in many low density instructions. But the methods are also extremely powerful in improving speed of learning and accuracy.

TRAINING AND EVALUATION OUTLINE

TASK PREPARE A DRAFT INDORSEMENT TO MILITARY LETTERS.

EVALUATION

CONDITIONS:

Given a copy of AR 340-15, a basic letter with a requirement to respond, the necessary facts, and a designated completion time.

STANDARD:

Within the allocated time:

1. The purpose and format will be correct in accordance with chapter 6, figures 6-13 through 6-19, AR 340-15.
2. The content will be organized logically enough and expressed clearly enough to satisfy your commander or supervisor.
3. The contents will be grammatically correct in accordance with chapter 7, AR 340-15.

TRAINING

1. Military letters are answered or forwarded by indorsement. An indorsement becomes part of the basic letter. Thus, a letter and any number of indorsements become a single, self-contained set of documents. The advantage is that at any point in the process of answering or forwarding the basic letter, you have a continuous strand of related information at one time and place.

2. Since the indorsement is used instead of a separate letter, you might expect the formats to be similar. In fact, the only difference between writing a letter and writing an indorsement is in preparing the heading. Figure 1 illustrates a military letter with a first indorsement written on the same page. Prepare an indorsement on the same page as the basic letter or a preceding indorsement only when there is enough room to type the entire indorsement.

a. An indorsement does not use a letterhead. The first line of the indorsement is the file symbol of the organization preparing the indorsement. The file symbol is followed by the date of the basic letter in parenthesis and the number of the indorsement. Indorsements are numbered consecutively beginning with the first indorsement to the basic letter.

2-IX-A-3

DEPARTMENT OF THE ARMY
Headquarters, 2d Battalion, 70th Infantry
Fort Benning, Georgia 31905

AFVE-7-CDR

3 July 1976

SUBJECT: Best Squad on ORTT

THRU: Commander
Company A, 2d Battalion, 70th Infantry
Fort Benning, Georgia 31905

TO: SSG Mike S. Foxtrot
Company A, 3d Battalion, 70th Infantry
Fort Benning, Georgia 31905

1. It is with considerable pride that I commend you and the members of your squad for an exemplary performance on the Squad ORTT. Of the 18 squads taking the test, yours scored the highest on each phase.
2. Your demonstrable excellence reflects the hard work and professionalism that goes into the making of a good rifle squad. Please pass my compliments to each member of the squad.
3. A copy of this letter will be placed in your personnel file.

SIERRA O. GOLF
LTC, IN
Commanding

AFVE-7-A (3 July 76) 1st Ind

DA, Co A, 2d Bn, 70th Inf, Fort Benning, GA 31905 5 July 1976

TO: SSG Mike S. Foxtrot, Co A, 2d Bn, 70th Inf, Fort Benning, GA
31905

I am proud to indorse the battalion commander's commendations.

CHARLIE C. CHARLES
CPT, IN
Commanding

Figure 1.
2-IX-A-3.1

3. When an indorsement cannot be completely typed on the same page as the basic letter or a preceding comment, begin the indorsement on a separate page. Figure 2 shows an indorsement prepared on a separate page. When an indorsement begins on a separate page, the only difference is that a **SUBJECT LINE** must be used.

4. When an indorsement must be continued on a separate page, use the format as shown in figure 3 to facilitate reference.

HEADING: Begin on 8th line from top edge of paper at left margin. Place reference symbol, indorsement number, and date, as shown.

DATE: Stamp or type the day, month, and year on the same line as the indorsement number.

SUBJECT: TYPE "SUBJECT:" and repeat subject phrase of basic letter beginning at left margin.

ABDZM (24 Nov 67) 1st Ind 28 December 1967
SUBJECT: Continuing an Indorsement

3. When an indorsement is continued on another page, repeat the subject of the basic letter. Use plain white bond paper.

FOR THE COMMANDER:

BEN J. FRANKLIN
CPT, AGC
Adjutant

Figure 3.

5. Variants of the indorsement are the rubber stamp and initialed indorsement (AR 340-15, figures 6-18 and 6-19). These indorsements are used at higher headquarters to transmit routine actions. Should you need to use these techniques, go to AR 340-15.

6. All other techniques of preparing an indorsement are the same used in preparing the military letter.

TASK NUMBER: 071-11B-8403

REFERENCE:

AR 340-15, Preparing Correspondence

2-IX-A-3.3

(REVISION OF EXAMPLE)

CONDITIONS: Given this guide, basic facts for an indorsement, and a deadline.

STANDARD: Indorsement having the characteristics shown.

GENERAL: Military letters are answered/forwarded by indorsement. Indorsements become part of the letter so the chain of correspondence can be kept together.



DEPARTMENT OF THE ARMY
UNITED STATES ARMY, HEADQUARTERS
WASHINGTON, D. C. 20315

AMM 3-12 27 Aug 1976

SUBJECT: I-BC AND I-OW, FY 1977

Cover under
Fifth United States Army
Fort Sam Houston, Texas 78234

*Wording of indorsements must be clear,
brief, and grammatical.*

Request this headquarter be provided with your projected officer
training budget projections for IOBC and TOAC cycles 1-77, 2-77, 3-77
and 4-77 as early as possible. Please use format shown in incl 1.

FOR THE COMMANDER:

*If the entire first indorsement will go
on the same page as the basic letter,
type it there.*

1 Incl
1. Sample Format
J.W. Fitch, Inc
COL, AGC
Adjutant General

*Your office symbol
Date from basic letter
"1st indorsement"
(Number consecutively)*

APERA-P (22 Aug 76) 1st Ind
S-15 Sep 76
HQ Fifth US Army, Ft Sam Houston, TX 78234
26 Aug 76
TO: Commander, 90th US Army Reserve Command, Ft Sam Houston, TX 78234

*Suspense date: Use only if
there is need, and you have
authority to impose it on addressee.*

Forwarded for necessary action and direct reply to originator, with
info copy to this HQ, ATTN: APERA-P.

FOR THE COMMANDER:

1 Incl
nc
D.S. Mardette
COL, AGC
Adjutant General

APERA-P (22 Aug 76) 1st Ind
S-15 Sep 76
Your agency ID line
HQ Fifth US Army, Ft Sam Houston, TX 78234
26 Aug 76 — *Date of the indorsement*

XX
TO: Commander, 90th US Army Reserve Command, Ft Sam Houston, TX 78234

No subject except when starting a new page

Forwarded for necessary action and direct reply to originator, with
info copy to this HQ, ATTN: APERA-P.

FOR THE COMMANDER:

1 Incl
nc
D.S. Mardette
COL, AGC
Adjutant General

*Tell what you did with inclosures:
No change ("no")
Withdrew all inclosures ("wd all incl")
Added Inclosure 2 ("Incl 2 added")
Leave this space blank if no inclosures are involved.
Other alternatives are covered in AR 340-15.*

Later indorsements follow the same requirements, except "subject" is given once per page.

8th line down

ARESC-DPT (22 Aug 76) 2nd Ind
HQ, 90th USA Reserve Command, Ft Sam Houston, TX 78234 28 Aug 76
SUBJECT: IOBC and IOAC, FY 77
TO: Commandant, US Army Infantry School, Ft Benning, GA 31902
ATTN: AMC-XYZ

1. Trainee projections requested will be forwarded in format required by basic communication NLT 25 Sep 76.
2. Projected change in POI for IOAC represents a significant improvement in concept of training of Infantry officers, particularly in view of reduced opportunity for attendance at C&GSC Command and Staff Officer's Course (long course).
3. FY 1977 training slot allocations are insufficient to maintain operational capabilities in USAR organizations. What support can be provided by the Infantry School to assist in making up the shortfall by locally conducted training? Are materials (Lesson plans, training aids, etc.) available for issue to USAR schools in 5A area for IOBC and IOAC branch material subjects? Alternative training proposals will be carefully evaluated.

FOR THE COMMANDER:

C.T. Korner
COL, AGC
Adjutant General

AMX-XYZ (22 Aug 76) 3d Ind
HQ, US Army Infantry School, Ft Benning, GA 31905 5 Sep 76
TO: Commander, 90th USA Reserve Command, Ft Sam Houston, TX 78234
ATTN: ARESC-DPT

1. Commander, US Army Combined Arms Center has been contacted regarding changes required in IOAC curriculum due to reduction in C&GSC class sizes.
2. This school presently has no resources available to assist area commanders in conduct of supplementary officer training on a regional basis. Concerns expressed in 1st indorsement have been passed to FORSCOM informally.

On second page or later, indorsements may be split between pages. Then these two lines are repeated.

AMX-XYZ (22 Aug 76) 3d Ind
SUBJECT: IOBC and IOAC, FY 1977

3. Recommend your concerns be brought to the attention of CG, FORSCOM, prior to 1 Oct 76 to secure resource allocation before start of FY 77.

FOR THE COMMANDER:

E.G. Butts
1LT, AGC
Asst AC

Plan

We will consider a plan to be a written guide for activities. Therefore, planning may be illustrated using pictures of the desired product, with responses specified in connected notes, like some of the other tasks we have discussed.

Scope. Planning tasks are assigned at senior enlisted levels and to officers. They range in complexity and criticality from planning field messing arrangements to drafting Operation Orders (OP ORDERS). Some types of plans are normally oral or even mental, but they can be illustrated with written notes. Even though such notes are not quite realistic, it is more important to have the advantages of printed examples.

Goal-oriented. People are more effective in performing almost any task when they are goal-oriented. That is especially true for planning, which is essentially a formalized, goal-seeking activity. The immediate goal, the plan, should usually appear first in the task summary, unless that is positively misleading. Notes should specify general characteristics of components, leaving details to the instructions for each step.

The opposite of goal-oriented instruction is a short-sighted, one-step-at-a-time approach, which is all too common, especially with planning. Sometimes it even approaches an extreme, exemplified by "First you get paper and writing implements, then...." It may be difficult to discuss goal-oriented thinking because focusing on physical details may seem to be "logical" and "objective." For instance, consider the procedure for developing task summaries (as described above) as a type of planning. It would have been easy to fall into the trap of telling you to begin by gathering all input information required on the Job and Task Analysis Worksheet. That might have flattered the people involved in developing and adopting that form. But you don't need all of that information for your immediate purpose, which is finding out how to perform the task.

The task structure diagram. Planning generally involves analyzing the total objective into manageable activities, just as a task structure diagram is an analysis of any task into subtasks and steps. This similarity makes a task structure diagram especially useful with this kind of task. Early instruction should follow the strategy of progressive differentiation, based upon the first few divisions of the task structure diagram. "Progressive differentiation" is sequencing instructional events by starting with a total concept or task, then dividing and subdividing it in several stages. Then the various parts of the plan should be explained one at a time.

If the parts of a plan do not involve any particular sequence, that should be implied in the way you word the instructions. Sequence is usually less important for planning than for other procedures. When sequence is involved, specify that also.

Planning often must take into account some other people in the planning system. In other words, the planner usually needs to know other people's responsibilities as well as his own, in order to coordinate in making a joint plan. (Several test questions in SQT have involved that kind of information.) Because of that, you probably should begin your task structure diagram at a level in the system that is higher than the individual's plan. For instance, if the task is to write an annex for an OP ORDER, you should write the total order in the left margin, derive the annex that is your concern, and then diagram the structure involved in developing the annex. You do not need to continue the other branches if they no longer have implications for the particular task being studied.

Supervisory planning. Many supervisory tasks are a kind of planning in the sense of goal analysis. Diagramming the task structure is often useful in developing task summaries for supervisory tasks. For instance, supervision often involves spotchecking work of subordinates. This entails adjusting the thoroughness of checking and the kind of feedback given, depending upon performance of the subordinate. Such adjusting is results-oriented, and can better be described in terms of goals and subgoals, than in terms of manipulations. The lack of fixed sequence is not especially troublesome, because many long chains can be described in a linear sequence, with the decision points implied by terms such as "suppose" or "usual consequences" or "expected result." The situation is much like FIP (electronic troubleshooting), except easier to illustrate because no equipment is involved.

CALCULATION

Calculation tasks involve deductive procedures beyond whatever could be assumed as common practices. Often a standard computation form is involved, and many lines may require complex instructions. In such cases, each step should be specified in a small handbook, so that the soldier could get an explanation whenever needed.

Calculation Using "Display"

Calculation often involves determination of data by using some kinds of table or schematic diagram. For instructing such tasks, your best tool is a picture of the data display, overprinted with an arrow to show the required scan pattern.

For example, consider the instructions for using log tables in Figure 4-14 which was developed to instruct one step of calculation in the surface-to-surface mission of the Nike-Hercules system. Using those instructions, soldiers could use the tables even if they did not know what a logarithm was. If they already knew something about logs, that would be even better. The instructions used a single example throughout all lines, and all explanations.

Calculation Without Display

Calculation without a data display may be illustrated with pictures of "scratchpad" figuring, with the response characteristics specified in connected note. Special care is needed to distinguish between the calculations and the instructions. Also, the "free-form" aspects of those calculations may make it difficult to provide a clear story line.

Using ADP Systems

Computer-based systems, usually referred to as automatic data processing (ADP), are far too important to ignore, even though those procedures involve a mix of data and equipment. The data aspects are the crucial factors, and that is the reason for discussing such procedures here. The hardware aspects are essentially the terminal interfaces, which are easy to picture, and which do not involve subtle manipulations.

line 11 Use log tables in TM 6-231 (Table II, pages 401-492, to find log dE. For example, say dE = -4,742 (ignore the + or -). First get the whole number for your logarithm, by counting the digits before the decimal, less one.

4,742 Four places, less one, so the log will be

3.

To get the decimal part of your log (mantissa), use the sequence of digits (regardless of decimal) as follows:

4742

N.	0	1	2	3	4	5	6	7	8	9	P.P.
4700	6720979	1071	1163	1256	1348	1441	1533	1625	1718	1810	
01	1903	1995	2087	2180	2272	2364	2457	2549	2642	2734	
02	2826	2919	3011	3103	3195	3287	3379	3471	3564	3657	
37	3036	3128	3217	3309	3401	3492	3584	3676	3767	3859	1
38	3951	4043	4134	4226	4317	4409	4501	4592	4684	4775	2
39	4867	4959	5050	5142	5234	5325	5417	5509	5600	5692	3
4740	6737783	7875	7967	8058	8150	8242	8333	8425	8516	8608	4
41	8700	8791	8883	8974	9066	9158	9249	9341	9432	9524	5
42	9614	9707	9799	9890	9982	0073	0165	0257	0348	0440	6
43	6760331	0623	0714	0806	0897	0989	1081	1172	1264	1355	7
44	1447	1538	1630	1721	1813	1905	1996	2088	2179	2271	8
45	2362	2454	2545	2637	2728	2820	2911	3003	3094	3186	9
46	3277	3369	3460	3552	3643	3735	3826	3918	4009	4101	
47	4212	4304	4395	4487	4578	4670	4761	4853	4944	5036	
48	5107	5199	5290	5382	5473	5564	5656	5747	5839	5930	
49	6022	6113	6205	6296	6387	6479	6570	6662	6753	6845	
4750	6766336	7028	7119	7210	7302	7393	7485	7576	7667	7759	
N.	0	1	2	3	4	5	6	7	8	9	P.P.

.6759615 = mantissa

So you would write 3.6759615 on line 11.

Figure 4-14. Calculation using a data display.

The discussion here is not supposed to be comprehensive, but only suggestive. If you are drafting instructions for a well-defined task, these suggestions are apt to be more confusing than helpful, so perhaps you should skip this section.

ADP systems involve special problems related to their complexity and the rigorous logic underlying that complexity. The magnitude of complexity is such that important aspects of any task will remain buried in the system, unless one has the key concepts for retrieval.

Chaos The Norm

Almost any ADP system involves numerous volumes of instructions. The novice typically spends many hours or days "swimming" in information, not knowing where to start. Even experts in other systems discover inaccuracies or inconsistencies in some of their concepts, even after weeks of studying the documentation. Experts in the particular system generally do not seem to understand the problems of the novice, perhaps because they are unaware of their own conceptual structure, which they come to take for granted. Or the experts just assume that everyone will have to struggle the way they did, and the way almost everyone seems to. But there are ways to organize the information, to illustrate the concepts, and to sequence instruction so that people will learn their tasks quickly, and without great effort. That requires special skill and considerable effort in development.

Task summaries might be written for various kinds of ADP tasks, which we will not consider in detail. But there are some general points that may be helpful.

Subordination in documents. Whenever a system involves several volumes a reader needs to know how their functions are related. First, a reader needs to know where to start, then where to go next. Ironically, the intended sequence is usually not apparent when documentation is complex. It is often hard to determine even reasonable options in sequence.

In deciding upon any sequence, a reader needs to know how manuals and their parts are subordinated (i.e., which part talks about another). For example, a table of contents always refers to the rest of the manual, so it is superordinate, and would normally be read first. A task summary will talk about other parts of the system, which are therefore subordinate. In writing task summaries, be sure to make clear all lines of subordination when referring to any other manuals.

Sequencing strategies. Two kinds of sequencing are important for rapid learning. One is "progressive differentiation"; that has already been discussed, but it is especially important for ADP systems. That is very much like the way the computer works, analyzing an operation into all possible constituents. Progressive differentiation is like "getting in tune with" the computer. It is also an exhaustive search for inconsistencies and omissions. A task structure diagram, as discussed above, is well suited to determination of such a sequence. This strategy should be followed early in the training, and should be continued for a much longer period of time for ADP systems than for other kinds of tasks.

The other important instructional strategy is to follow the job sequence. The computer has an analogous process, which is using "in real time" the subroutines that have been programmed. This strategy is also a check for inconsistencies and omissions. It can go even further, in checking the sufficiency of instructions, if an instructor is sensitive in observing novices during tryouts.

Progressive differentiation and job sequence are instructional strategies within a unit of instruction. An instructional developer needs to record the specialized operations and concepts that are assumed to be covered in previous units, so that all such assumptions may be checked whenever the sequencing of units is changed. Sequencing of units may also be determined by progressive differentiation of large blocks of instruction. These two kinds of considerations in sequencing units do not usually conflict. If they do, the conflicts can be resolved by shifting small parts of some units.

Analogical pictures. People depend upon visual images in thinking and performing tasks, especially with ADP systems. The more complex the task, the more critical is a rich supply of appropriate images. ADP tasks require greater emphasis on understanding than most Army tasks, so a different kind of illustration is appropriate, especially pictures that are both (1) realistic in appearance, and (2) good logical analogies of computer functioning. An example (Figure 4-15) was developed for the BETA (Battlefield Exploitation and Target Acquisition) system. From that image, one can deduce what each key does, in terms of what picture is sent, where it goes, and whether it replaces the other picture, or merely "bumps" it to another screen.

Another important kind of logical analogy is a "path" chart of some kind (e.g., a flow chart). That allows a person to see where he is going, and to see the consequences of alternative paths. It is one of the principal means of transcending the limitations of the particular moment in task performance, and the particular path one has chosen. However, in using flow charts for instruction, it is very important to "cluster" the steps in more inclusive operations, so as to not exceed the capacity of a person's short-term memory (i.e., or else you will "make his head swim"). One way of doing that is to box off several steps with dotted lines, and label the larger box with a common-sense concept.

INSURING COVERAGE

Task performance instructions should be sufficient for task performance even when the circumstances are somewhat different from those in the example. Insuring such generalization is especially difficult when procedures involve data because the numbers and facts always vary from one problem to another, and that often results in subtle changes in the method the soldier must use to solve them.

The key to insuring generalization from examples is to include all operations, however elementary, that the class of problems might involve. For instance, in the instructions for using log tables in Figure 4-14, a "-" number was deliberately selected to insure that the soldier gets practice in dropping the sign. Such elementary operations are associated with a task cue, which we shall refer to as "elements." The "-" sign is an example of an "occasional" element, since it is not always involved in this general class of problem. A "regular" element is one that occurs in every instance. The occasional elements are more elusive, and therefore more likely to be neglected in instructions. However, regular elements may also be neglected in instructions, when the cues for an action is not mentioned. Then the soldier may wonder "how did they get that?"

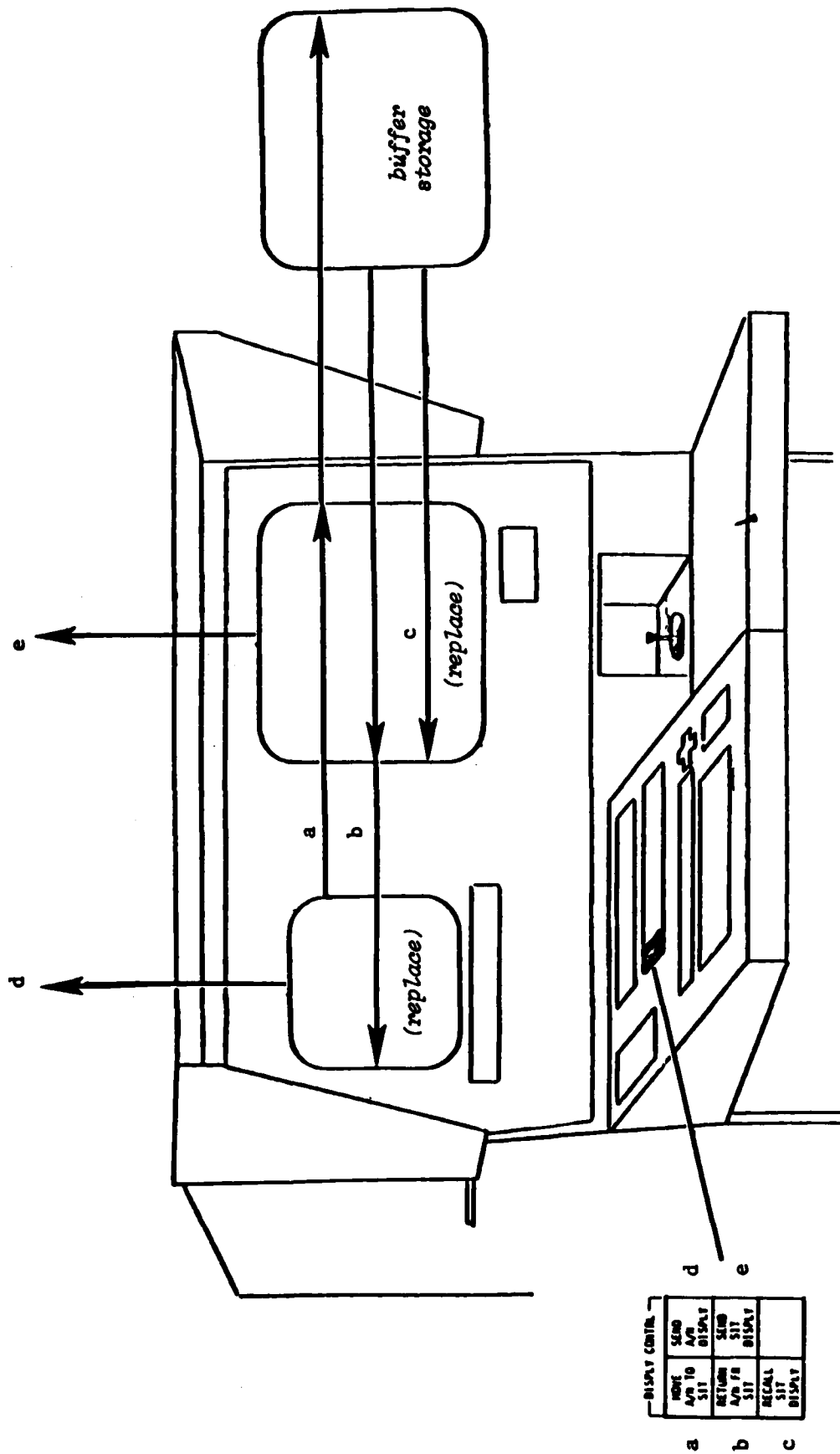

Figure 4-15. Analogical illustration to show the functions of DISPLAY CONTROL panel.

You can be careful to include all regular and occasional elements in your instructions, but you cannot include all possible values. Values are the specific facts and figures involved in a problem. Each response involves no more than one value from a scale. People can generalize to other values on the same scale, so long as there is no additional element involved. Value scales may be either discrete (e.g., left-right) or continuous (e.g., deflection setting in mils). Any example is only one instance, with particular values, but it may involve all elements, both regular and occasional. Another example of this kind of analysis is given in Chapter 5, in connection with a job aid (lube order).

Sometimes it seems difficult to include all regular and occasional elements in a single example. Then you must decide whether to try harder to cover everything in one instance, or whether to branch into alternate instructions for different sets of circumstances. For instance, in the example on indorsements, there could be one set of instructions for indorsements that start at the top of the page, and another for indorsements that start in the middle of the page. That would be about as easy to follow in performing from the instructions, but if the soldier had to remember what to do, then he would either have to remember twice as much, or somehow combine the two sets of instructions. Combining them would require comparing them for similarities and differences, which is laborious. In deciding whether to branch or to combine, the major considerations are as follows. Decide whether you can make a single set of instructions, and whether it is worth the effort, considering the criticality of the task and number of people who will be using the instructions. If people must eventually learn to perform without the instructions, then combining directions has a distinct advantage. If the instructions branch to alternatives, there should be distinctly different circumstances for deciding which branch to take.

SECTION 4: COMPONENT SKILLS

Component skills are kinds of performance that happen as brief instances, in contrast with procedures, which can be instructed as long chains of actions in fixed sequence. Many component skills have been identified as separate tasks in current Soldier's Manuals. This may be confusing if you try to write a task summary as if they were procedures. Quite different kinds of wording, structure and illustrations are appropriate.

Often component skills are closely associated with a group of procedures as subroutines. Sometimes a component skill may be specific to a particular procedure. Then it should be instructed as a part of that procedure. In such cases, it is distinguished from the rest of the procedure only because different instructional techniques are appropriate.

Component skills involve concrete performance. They are not vague, abstract, or hard to define.

Task structure diagrams are not generally useful for analyzing component skills. You simply will not be able to draw one, as you could with procedures.

BRANCHING INSTRUCTIONS

Component skills, as a group, have little in common, so you only need to read the subsection for kind of task summary you're writing: Identification, Decision-making, or Communication (these are defined below). After you have read that and drafted your task summary, skip ahead to the next chapter.

IDENTIFICATION

Identification is a matter of perceptual discrimination, usually visual. Identification of equipment involves discrete response categories, which are associated with types of manufactured goods, especially vehicles and weapons. Other kinds of perceptual discrimination we call concept formation. The more important kinds, in Army jobs, involve continuous stimulus properties that are often somewhat vague (e.g., good camouflage patterns).

Identification of Equipment

Identification of equipment involves sorting into fixed categories, and constant patterns of parts. That constancy, however, is subject to stimulus degradation, especially as a function of range. Some variation in the equipment is also possible. For example, Soviet tanks may jettison their external fuel tanks.

Identification of equipment is customarily identified as a separate task. That is a practical arrangement because it involves substantial amounts of training time and resources, and distinctive training methods, particularly comparison of pictures or models. The development of such training programs involves many technical considerations, including size of imagery, selection of vehicles, comparative views, tactical needs for identification skills, and media selection. These issues do not have sufficient generality for discussion here.

Concept Formation

In military tasks, concept formation generally involves discrimination of subtle stimulus characteristics, or patterns of such characteristics (e.g., recognizing symptoms of immersion foot). Sometimes there are no discrete categories for classification (e.g., camouflage patterns are judged on a continuous scale, from good to bad).

Concept formation is almost always associated with a particular procedure, and instructed as part of that task. Consequently, it has been discussed in relation to other kinds of tasks in this manual and will not be discussed here.

DECISION-MAKING

Decision-making involves a very brief performance in which a soldier is to apply certain rules in determining a course of action. Our focus is on basic individual combat

decisions (e.g., react to flares). Often those involve techniques of movement, either driving or on foot. Because each episode is short, it is not generally feasible to test these skills with HOC. However, they are rather easy to describe in words and pictures without vagueness, so multiple-choice testing is appropriate.

The most important rule for instructions is to state the decision rules clearly and simply at the start. Use a format that implies the logic involved in the decision, such as a table or flow diagram. Leave all qualifications and minor variations until later. For example, compare the instructions on "react to flares" in the original and revised versions on the following pages.

Decision-making often involves choice of movement techniques (e.g., Figure 4-16). This example involves a choice of technique, and for such choices, comparative illustrations are appropriate. Be sure to distinguish which is good and which is bad.

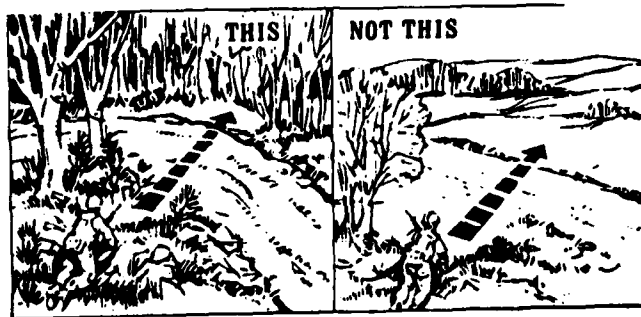

Figure 3.

5. To go over a wall, roll quickly over the top to avoid going over upright (figure 4). When crossing an obstacle such as a wall, use the buddy system: one man covers while one crosses.

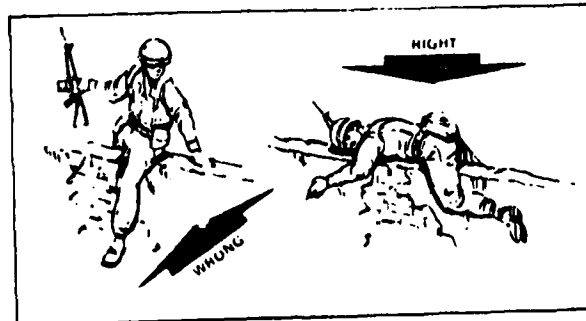

Figure 4.

Figure 4-16. Comparative illustrations showing proper technique (11C, p. 2-II-B-5.3)

TASK NUMBER: 071-326-0511

REACT TO FLARES

CONDITIONS:

At night, upon hearing a flare rising or when suddenly illuminated by a ground or overhead flare.

STANDARDS:

React as specified for each situation listed in the performance measures.

PERFORMANCE MEASURES:

React as follows for each situation:

1. **Ground flares: move out of the illuminated area, and:**
 - a. When alone, reorient yourself and continue mission.
 - b. As a member of a combat element, regroup (by SOP or as instructed) and continue mission.
2. **Overhead flare with warning (sound of rising flare): assume a prone position (behind concealment when available) before the flare bursts.**
3. **Overhead flare without warning:**
 - a. Get into the prone position, making maximum use of nearby cover, concealment, and shadows until the flare burns out. Close one eye to protect your night vision; observe with the other. (See figure 1.)
 - b. When crossing wire obstacles where the prone position is not possible, crouch low until flare burns out.
4. **Ground or overhead flare while under direct enemy fire or followed by direct enemy fire: use fire and maneuver (select temporary position, rush, low crawl, etc., as specified in applicable tasks) as you would during daylight.**

2-II-B-4.1



Figure 1.

REFERENCES:

FM 21-75, Combat Skills of the Soldier (Revised Edition, TBP)
TEC Lesson 020-071-1049-F, Reacting to Flares

2-II-B-4.2

TASK 42: React to Flares

Conditions: You are suddenly caught in the open by a flare.

Standard: React as specified in each situation.

Performance:

1. Decision rules:

- | <u>situation</u> | <u>action</u> |
|--|--------------------------------------|
| a. Overhead flare,
and <u>not</u> under direct fire | then drop to the ground and freeze |
| b. Overhead flare,
and under direct fire, | then get out of the illuminated area |
| c. Ground flare (trip wire) | then get out of the illuminated area |

Never freeze standing when illuminated by a flare.

2. Reasons:

- You want to be undetected if possible.
- If you are under direct fire, you have been seen already.
- Ground flares are used by troops close-in, so you cannot hope to get by unseen.

Also, you cannot hope to hide standing up.

3. Other considerations:

As an overhead flare rises, you may hear a hissing sound, which will give you a few seconds to find a concealed position.

Close one eye to protect your night vision, and observe with the other.

Whenever you are under direct fire, use fire and maneuver as you would in daylight (rush, crawl, etc.).

If you are crossing wire obstacles and cannot drop flat, crouch as low as possible.

When the flare burns out, continue your mission.

When other kinds of tasks involve alternate methods, there should generally be a short decision program at the start. That is to specify when to use each method, before describing them. For example, in the instructions on the M16 plotting board, there should be a short decision table specifying when to use each of the four kinds of plots.

COMMUNICATION

Communication skills involve learning the meanings of a set of signals, and developing fluency in using those signals in realistic performance situations. Usually task performance instructions should begin with a chart defining the meaning of every signal in the set. Then there should be specified exercises for gaining the necessary proficiency in using the signals.

Voice Communication

Some examples of voice communication tasks are: transmit a radio message, use "challenge" and "password," and call for/adjust indirect fire. In practice, such skills involve some regularity in sequence, but usually not enough to qualify as procedures. However, much of the practice should be like practicing procedures, but with some variation to insure that the soldier will be prepared to adapt and still meet standards.

As an example, task performance instructions for transmitting a radio message are presented on the following pages. The main problem with the original was that it was not designed for practice of the skill. Three equivalent-form exercises were provided for some variation. The three forms could be justified on the basis of this task being tested in SQT. Note in the scorer's script that the exercise involves two occasional elements: the "say again" part and the negative response to the request. The radio message was treated very much like a procedure for instructional purposes.

Those task performance instructions did not define all signals (or conventions) at the start. That was under the assumption that those would be covered in another exercise. The developer should record that in item 20 of his worksheet, and later check it out. Part of the set of signals is the phonetic alphabet, which was provided as a backup exercise at the end. If most soldiers had trouble with those basic signals, that drill should be moved to the start of the exercise.

Notice that the "o" notation was not useful here because we had to distinguish particular words, so underlining was used instead. The "o" notation is useful in mechanical adjustments, when there is an underlying continuum. Such adjustments must have tolerance levels, because it is impossible to be exact.

Use Hand Signals, or Mechanical Signals

Often with tasks of this sort, it is sufficient to define the set of signals only in a chart, which can be kept as a reference. For example, consider the chart of hand signals for placing an aiming post with a mortar (Figure 4-17). In such tables, try to avoid abstractions, such as "left" and "right." The obvious question is "whose left, the sender or the viewer?" Notice the more direct method used in the revision (Figure 4-18). A

Transmit and Receive a Radio Message

Conditions: Given one of the cards below, send message while your supervisor or another soldier acts as receiving station, and checks your performance against the script on the following page.

Standard: 2 minutes or less, with all underlined parts correct.

Performance:

(see note*)

RADIO MESSAGE 1

You must transmit this message:

TWO ENEMY TANKS 300 METERS EAST OF POULA.
REQUEST PERMISSION TO TAKE THEM UNDER FIRE.

Your call sign is: R93

Your receiving station's call sign is: N64

RADIO MESSAGE 2

You must transmit this message:

TWO ENEMY TANKS 300 METERS SOUTH OF TRIOL.
REQUEST PERMISSION TO TAKE THEM UNDER FIRE.

Your call sign is: L29

Your receiving station's call sign is: S72

RADIO MESSAGE 3

You must transmit this message:

TWO ENEMY TANKS 800 METERS NORTH OF GRIEK.
REQUEST PERMISSION TO TAKE THEM UNDER FIRE.

Your call sign is: L93

Your receiving stations' call sign is: N62

*Note: If you have difficulty in remembering the phonetic spelling, practice with the phonetic drill at the end of this task, and then come back to this exercise.

SCRIPT FOR PERSON ACTING AS RECEIVING STATION AND SCORER

2 minutes maximum each message

1. Message 1: "November Six Four, this is Romeo Niner Tree. Message, over."

(He must say the words that are underlined.)

Scorer replies: "November Six Four, over."

Message: "Two enemy tanks tree zero zero meters east of Poula. I spell, Papa Oscar Uniform Lima Alpha. Poula. Request permission to take them under fire, over."

Scorer replies: "Say again all after REQUEST, over."

Message: "I say again all after REQUEST. Permission to take under fire, over."

Scorer replies: "Negative. Hold your fire and give me a SITREP in 5 minutes, over."

Message: "Wilco, out."

2. Message 2: "Sierra Seven Two, this is Lima Two Niner. Message, over."

Scorer replies: "Sierra Six Four, over."

Message: "Two enemy tanks zero zero meters south of Triol. I spell, Tango Romeo India Oscar Lima. Triol. Request permission to take them under fire, over."

Scorer replies: "Say again all after REQUEST, over."

Message: "I say again all after REQUEST. Permission to take under fire, over."

Scorer replies: "Negative. Hold your fire and give me a SITREP in 5 minutes, over."

Message: "Wilco, out."

3. Message 3: "November, Six Two, this is Lima Niner Tree. Message, over."

Scorer replies: "November Six Two, over."

Message: "Two enemy tanks eight zero zero meters north of Griek. I spell, Golf Romeo India Echo Kilo. Griek. Request permission to take them under fire, over."

Scorer replies: "Say again all after REQUEST, over."

Message: "I say again all after REQUEST. Perwission to take under
fire, over."

Scorer replies: "Negative. Hold your fire and give me a SITREP in
5 minutes, over."

Message: "Wilco, out."

PHONETIC DRILL

Each block contains all letters and numbers in random order. Say the phonetic spelling for each letter or numeral, reading across the rows in each block. For variation, read down the columns, or backwards. Drill until you can give one block without hesitation on any letter or numeral.

block 1

S	I	4	G	Q	K	R	L	U
C	1	Y	T	7	V	Ø	P	Z
X	9	H	6	B	D	A	M	E
O	W	5	3	N	2	F	8	J

block 2

4	Y	7	8	W	N	5	F	A
E	3	Z	R	9	U	S	Ø	1
T	B	M	H	G	J	K	I	L
P	X	2	Q	G	V	O	D	6

block 3

7	P	8	K	C	M	Ø	1	6
V	J	Z	S	X	T	3	E	2
5	U	I	A	Q	B	H	G	Y
N	9	4	L	R	F	D	W	O

block 4

O	1	Y	Q	F	4	S	6	8
K	V	E	A	W	M	R	X	1
U	5	B	J	7	N	L	H	T
P	Z	2	9	3	G	Ø	C	D

KEY

A ALFA (AL FAMI)	B BRAVO (BRAH VOH)	C CHARLIE (CHAR LEE)	D DELTA (DELL TAMI)
E ECHO (ECK OH)	F FOXTROT (FOHS TROT)	G GOLF (GOLF)	H HOTEL (HOH TEL)
I INDIA (IN DEE AH)	J JULIETT (JEW LET)	K KAY (KEY COH)	L LIMA (LEE MAMI)
M MIKE (MINE)	N NOVEMBER (NO LEB BER)	O OSCAR (OSS CAH)	P PARA (PAH PAH)
Q QUEBEC (KE BECK)	R ROMEO (ROH OH)	S SIERRA (SEE AIR PAH)	T TANGO (TANG COH)
U UNIFORM (YOU NEEL FORM)	V VICTOR (VIK TAH)	W WHISKEY (WISS KEY)	X XRAY (ECKS RAY)
Y YANKEE (YANG KEY)	Z ZULU (ZOO LOO)	1 ONE	2 TWO
3 TREE	4 FOUR	5 FIVE	6 SIX
7 SEVEN	8 EIGHT	9 NINE	Ø ZERO

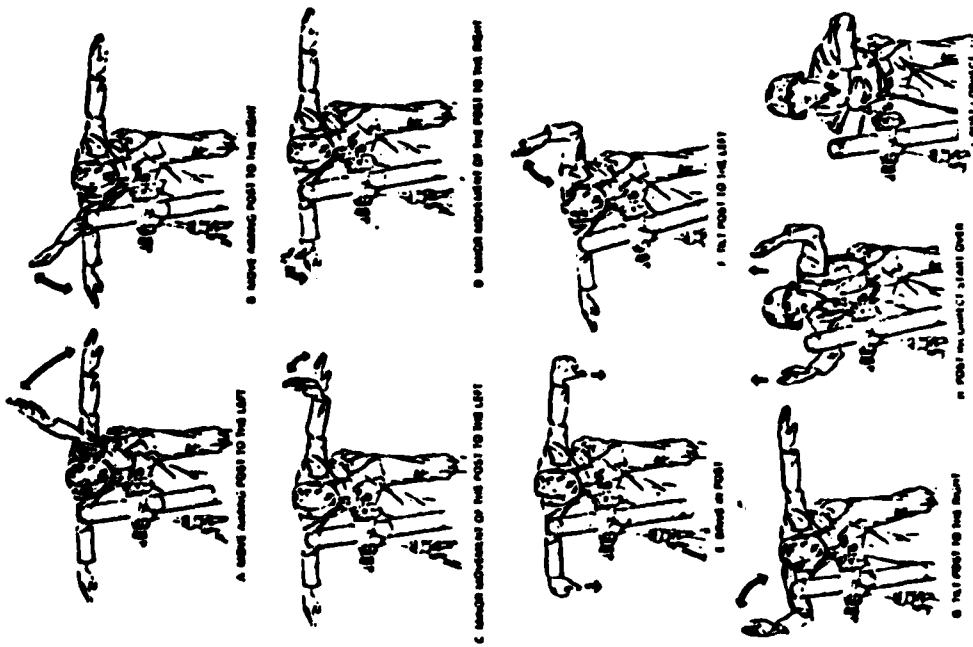

Figure 4-17. Correspondence of codes (11C- p. 2-VIII-A-8.2).

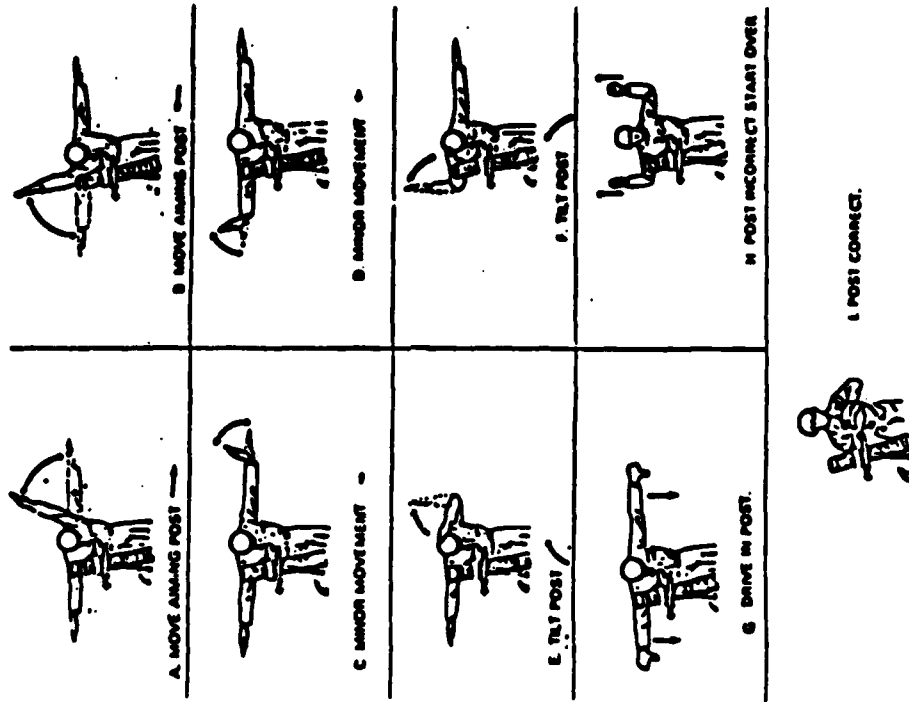

Figure 4-18. Revision of example, avoiding "left-right" confusion.

comparable example for mechanical signals is shown in Figure 4-19. Such subroutines should be placed at the start of a group of tasks, if they are used in several tasks. But if they are specific to one task they should be placed there.

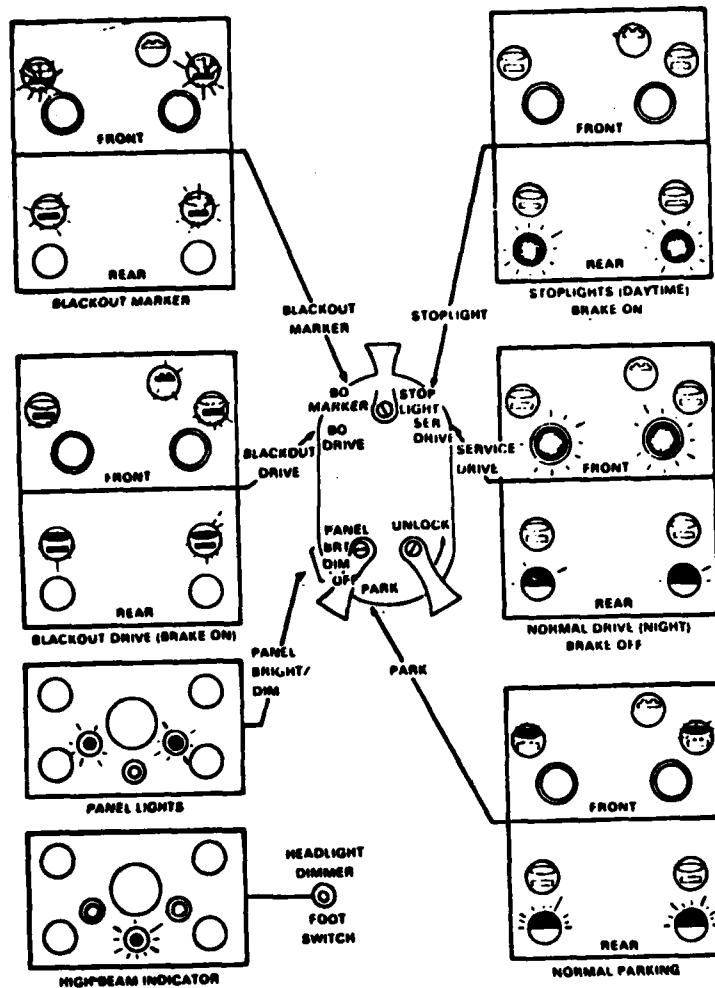

Figure 4-19. Signals, meaning (11C, p. 2-VII-A-3.3)

Use Job Aids

A job aid is a set of instructions used to guide performance while performing the job. An example is using lubrication orders. Job aids use a standard format and set of acronyms and other symbols to indicate required actions. Those practices constitute a set of signals, which qualifies such tasks as communications exercises. At first, that may seem a strange classification because the performance generally involves manipulation of equipment. However, in "generic" tasks such as using lube orders, the critical part seems to be learning the symbols and format. If a soldier can use a lube order for one piece of equipment, he is expected to be able to use almost any lube order. That is why it is called a generic task.

The symbols used in job aids must be somewhat cryptic, or else the aid would be much too cluttered and clumsy to use. The symbols are generally meaningful, so they are usually learned quickly, often in one trial. That is good for learning, but it makes the problems elusive. Many people seem to assume that there is no need to make provision for learning.

Consider the instructions for a lubrication order on the following page. The elements are defined in italics in the overprint, to distinguish them from the picture of the lube order.

The way to use such a chart is to look it over, and then try to do the task. Probably a person would remember almost all of the meanings, and performance of the actions will be routine. Whenever the meaning of a symbol is not remembered, the chart can be used as a reference.

The example involved only one instance: lubrication of one point. That instance was selected so as to involve all elements that the reader would have to perform. ("Instances" and "elements" have been discussed above, under the heading of "Insuring Coverage.") Note that the element "(Both Sides)" is an occasional element, and the selected instances contained that element. "W" was connected with its definition in the key below, but the alternative values "D," "Q," "S" and "A" were not included in the instance explained.

One kind of element was not included in the first instance: the blank that we marked "same" where a ditto was merely implied. Therefore, that element was covered in the second instance.

In designing instructions like that, a developer should first identify an instance (lubricating one point) and analyze that instance into elements. Then one should review other instances to see whether all kinds of elements were involved in the first instance. One instance should be selected for instructional illustration, on the basis of covering all kinds of elements. If occurrence of certain elements precludes the inclusion of others, some elements may be illustrated in another instance.

USE A LUBRICATION ORDER

Conditions: Given a Lubrication Order, the item of equipment, and directed to perform daily, weekly, quarterly, semiannual, or annual lubrication.
 Standard: Follow all items specified below.
 Performance:

LUBRICATION ORDER

LO 5-4610-218-12

17 NOVEMBER 1978

WATER PURIFICATION UNIT, VAN TYPE BODY MOUNTED
 ELECTRIC DRIVEN, AC 115, 208V, SINGLE AND 3
 PHASE, 60 CYCLE 1:20 TO 2:10, 1500 RPM
 (MFC MODEL 1MC-1500S)

Reference: TM 5-4610-218-1, 1978 Ed.

Intervals and related tasks are listed in the table below. The lowest level of maintenance authorized to lubricate a point is indicated by one of the following: (a) operator/crew, or (b) organizational maintenance.

Intervals are listed in hours of operation. The time you need to allow for a particular interval is listed in the table below. The equipment under maintenance should be in the ready-to-operate condition. You may extend the interval during periods of low activity, but you must observe applicable regulations.

LUBRICANT - INTERVAL

INTERVAL	TIME ALLOWED	INTERVAL	TIME ALLOWED
D	05	D	05
W	10	W	10
Q	15	Q	15
S	20	S	20
A	25	A	25
M	30	M	30

INTERVAL - LUBRICANT

INTERVAL	LUBRICANT
D	SEA-APG-PD1
W	SEA-APG-PD1
Q	SEA-APG-PD1
S	SEA-APG-PD1
A	SEA-APG-PD1
M	SEA-APG-PD1

MINIMUM BEARING ASSEMBLY

LUBRICANT - INTERVAL

ITEM	APPLICABLE	APPLY	APPLY	APPLY	INTERVALS
SEA-APG-PD1 Lubricating the bearing	SEA-APG-PD1	SEA-APG-PD1	SEA-APG-PD1	SEA-APG-PD1	D = 10 hours of duty
SEA-APG-PD1 Lubricating the engine rollers	SEA-APG-PD1	SEA-APG-PD1	SEA-APG-PD1	SEA-APG-PD1	W = 30 hours or weekly
SEA-APG-PD1 Lubricating the gear	SEA-APG-PD1	SEA-APG-PD1	SEA-APG-PD1	SEA-APG-PD1	Q = 60 hours or monthly
SEA-APG-PD1 Lubricating the drive	SEA-APG-PD1	SEA-APG-PD1	SEA-APG-PD1	SEA-APG-PD1	S = 150 hours or quarterly
SEA-APG-PD1 Lubricating the motor	SEA-APG-PD1	SEA-APG-PD1	SEA-APG-PD1	SEA-APG-PD1	A = 300 hours or semi-annually
SEA-APG-PD1 Lubricating the drive	SEA-APG-PD1	SEA-APG-PD1	SEA-APG-PD1	SEA-APG-PD1	M = 1000 hours or annually

ALL TEMPERATURES

NOTES:

1. This lubrication order is for equipment in the ready-to-operate condition. It is not to be used for equipment in the ready-to-operate condition.
2. If a lubrication order will remain with the equipment at all times, it is not to be removed from the equipment.
3. If the lubrication order is not to be removed from the equipment, it is to be removed from the equipment.
4. If the lubrication order is not to be removed from the equipment, it is to be removed from the equipment.

DR. B. W. B. B. B.
 General, United States Army
 Chief of Staff

J. C. P. H. H. H.
 Brigadier General, United States Army
 The Adjutant General

DISTRIBUTION: To be distributed in accordance with DA Form 13 25A.
 Operator maintenance requirements for Water Purification

Type of Equipment

How Much Time to Allow

Where to Lube. ("Both sides" means to lube same point on other side also)

How

Type of Lubricant

SECTION 5: CRITERION-DRIVEN PERFORMANCE

Criterion-driven performance is the classification for any task that has not been specified in terms of concrete actions (the so-called "soft" skills). Sometimes it cannot be so described, because of the nature of the actions, and sometimes it simply has not because of insufficient analysis. In any case, it is desirable to reduce at least part of the task to a procedure, whenever possible, because that simplifies training and performance.

Troubleshooting is an example of a kind of task that was originally criterion-driven performance, for the most part. The task objectives were stated in terms of "finding out what's wrong," with only general strategies for methods. Over the last 30 or 40 years, many fault isolation procedures (FIP) have been developed. Yet, there still is occasional need for traditional troubleshooting approaches. The development of FIP, however, has substantially reduced the amount of work and the need for expertise.

SUPERVISORY TASKS

In other kinds of tasks the criteria are not concrete, and the sequence of performance is not a major consideration. That is the case with many supervisory tasks, many of which have not been identified because they are difficult to analyze. In current Soldier's Manuals at skill levels 3, 4, or 5, there are many tasks that we classify as procedures with data, particularly planning. Those are supervisory tasks, but as a group they hardly seem representative. There is a need for many more that should be included, especially interpersonal and monitoring skills. As soon as such skills have been identified, the first thing to do is to reduce vagueness by specifying criteria. If some of the criteria seem elusive, they should be described tentatively and refined as they are applied. The system can be refined in practice. An example of a criterion-driven performance is the task "prepare and conduct performance-oriented instruction," which is discussed below. It involves criteria that are not concrete, so it probably never will be reduced to a procedure.

PREPARE AND CONDUCT PERFORMANCE-ORIENTED TRAINING

This is a skill that is common to written and oral instruction on a wide variety of hardware systems, and many kinds of performance. But the main problem, it seems, is that the method is poorly defined. Much has been written about these skills, but most of the discussion has been a matter of emphasis, in general terms, rather than definite criteria.

The following are suggested as criteria for performance-oriented instructions, roughly in order of importance:

1. Job sequence. Did the presentation follow the order of events that is necessary on the job?
2. Simulation. Was it apparent what the job environment looked like every step of the way? (Other senses also may be involved, but vision is by far the most important.) This may be achieved by photos or hardware, as long as the simulation is sufficient to "give the picture" without using an inordinate amount of time. Sometimes it may be

desirable to provide for actual manipulations, if the responses themselves are new and difficult, but do not restrict your thinking about simulation to manipulatory gadgets. It may be difficult to determine responsibility for simulation, however, because individual instructors usually lack the resources to develop simulators or even a well-designed set of pictures.

3. **Meaningfulness.** Is the purpose of each step apparent even to the novice? Progressive differentiation is likely to be a most useful instructional strategy. The traditional 5-minute introduction and tie-in may not be enough, but usually it is too much. A common misconception is that the performance-oriented approach is anti-theoretical. An instructor should introduce theory, but only as much as is needed, when it is needed (job sequence). And theory should be accompanied by specific examples (a point that is a cornerstone of this report).

4. **Active participation.** Overt performance should be elicited whenever there is a reasonable expectation of its being correct. That performance should be a part of the job performance being taught, and not some trivial question that anyone is bound to answer correctly. It seems there is a rather sharp dichotomy between specialized knowledge or concepts which the novice has no way of knowing, and general concepts, which are abundant in daily life. For example, it is useless to ask a novice where to find a particular fault isolation procedural table (answer: "page 26"), but someone is apt to know how to find it (answer: "look in the table of contents").

A problem with the above criteria is that they are "criterion-referenced" rather than "norm-referenced." It is very difficult to compare instructors when the tasks differ, but they can be counseled about what would be an improvement.

The most common deviation from performance-oriented instruction is "front-loading" (i.e., explaining all of the background information and concepts before describing the procedures). It is difficult to sort out information or concepts according to the steps where it is needed. That difficulty is compounded by the fallacious "conceptual bag" instructional strategy (i.e., explaining everything about a concept that is only involved in a limited way).

FUTURE RESEARCH NEEDED

Other supervisory tasks are also poorly defined. Further research and analysis may clarify such performances. But in the mean time, one should admit that there are substantial areas of vagueness and develop criteria for evaluation even if procedures cannot be specified.

Our suggestions in this section admittedly are not comprehensive. We only suggest an approach, which needs refinement through application.

Chapter 5

TRYOUT AND REVISION

REVIEW

Review your draft to keep it "lean." Remember that you will try it out with some soldiers, and if the instructions are insufficient, they will not be able to do the task. You will always be surprised by what they find easy, and by what causes problems. All of us who develop instructions must be prepared to have our grandiose constructions collapse like a house of cards, and then to rebuild an elegantly simple set of instructions.

SIMPLIFICATION

The various rules for text and illustrations involve three basic principles for simplification: (1) relevance, (2) directness, and (3) sufficiency. Apply these criteria sequentially as described below.

Relevance

Screen all items of information in your task summary for relevance. Eliminate any irrelevant items that may have escaped your notice.

Directness

Directness is minimizing the number of steps required of the reader in following instructions. Often, reading a task summary requires numerous steps besides those involved in task performance. By eliminating extraneous steps, you may provide a "shortcut."

Sorting by responses. The first way to eliminate steps is to insure that task-relevant information is sorted into clusters, one for each response. After each cluster of information there is an implied "execute" command so that the reader could act on it immediately, without reading further. That is quite different from conventional instructions, which require reading everything before taking any actions, and then mentally sorting out the information so that it applies to particular responses. Even if the reader is only previewing the instructions, clustering by responses provides a structure for comprehension and recall.

Reducing each cluster of instructions. Another way to minimize steps is to reduce required reading for each response. Be sure that the text is related directly to the illustrations. Check for illustrations that are redundant with the text, and for multiple illustrations when a single one would do. Look for items that have already been covered elsewhere, and for extraneous items. One way to detect them is to ask whether it is really part of the story line, or only an adjunct, "just in case someone needs it."

Also keep looking for response specifications where you could justify more general statements. In terms of your task structure diagram, that means moving back to the left. This is a way to combine two or three steps in one, and to also make it easier to remember. Look for "busy" illustrations and eliminate some lines.

Sufficiency

Sufficiency is a matter of assuring that each cluster of instructional information will produce the intended response. Sufficiency consists of having (1) a comprehensive rule specifying each response, and (2) an "embedded" example involving all response elements.

Comprehensive rules. A comprehensive rule is one that specifies the responses under all circumstances. Such a rule may be a formula, a set of qualifying conditions, or even a simple listing of all acceptable responses. It is not a matter of discussing a lot of details.

Embedded examples. An embedded example of a procedure is one that is continued throughout the instructions as each response is specified by rules. This allows immediate application of each rule as it is defined. Check to be sure that the example involves all kinds of elements that the soldier might encounter.

Reviewing Other Rules

Review the rules in Chapter 2, particularly those under "Language" to see whether your draft conforms. If you have had problems because the procedure given here does not seem appropriate for your task, please submit that in writing through your supervisor so that we can work out the difficulties for everyone.

Notes

Review your notes on specialized concepts and operations (traditionally under the term "knowledges/skills"). Then review your draft in relation to those notes to determine whether you have listed all the items that you are assuming will be covered in another section. Also, try to list specialized concepts and operations that you have covered, but which might better be shifted to another section.

A similar idea is the "skills hierarchy" that is often used in instructional analysis. This term was avoided because it seems to imply that any subordinate skill is included entirely within a higher level performance. This is often the case, especially in mathematics. But often two tasks have only a few responses in common. The idea of "specialized concepts and operations" seems more descriptive when there may be varying degrees of overlap between tasks, and more descriptive of the kinds of overlap.

- In our example on the M203, the only item under "specialized concepts and operations" was basic aiming technique for the weapon. Our task example was simple, which most tasks are, so there are very few implications for other sections. The only thing you have to do as a result is to insure that "engage targets" is sequenced before your

instructions. Your note should be entered on TRADOC Form 550 under SKILLS/KNOWLEDGES and kept on file so that anyone considering re-sequencing of tasks in the future can take it into account.

A contrasting task example is "ground-mount an 81-mm mortar," which was discussed in Chapter 2. Mortar gunnery is an unusually complex task area, and there are many considerations in grouping tasks and devising common subroutines to cover specialized concepts and operations.

Specialized operations. Some common operations that should be instructed early are: (1) relay the mortar, (2) traverse, (3) adjust elevation, (4) adjust deflection, and (5) level in elevation and deflection. In mortar gunnery, these subroutines should be instructed in a general section at the start, rather than in the first task in which they are used. These subroutines are just complex enough to be a substantial interruption of any task instructions.

An example of a subroutine is setting deflection on the mortar (Figure 5-1). All of the operations should be illustrated on the mortar in its normal configuration.

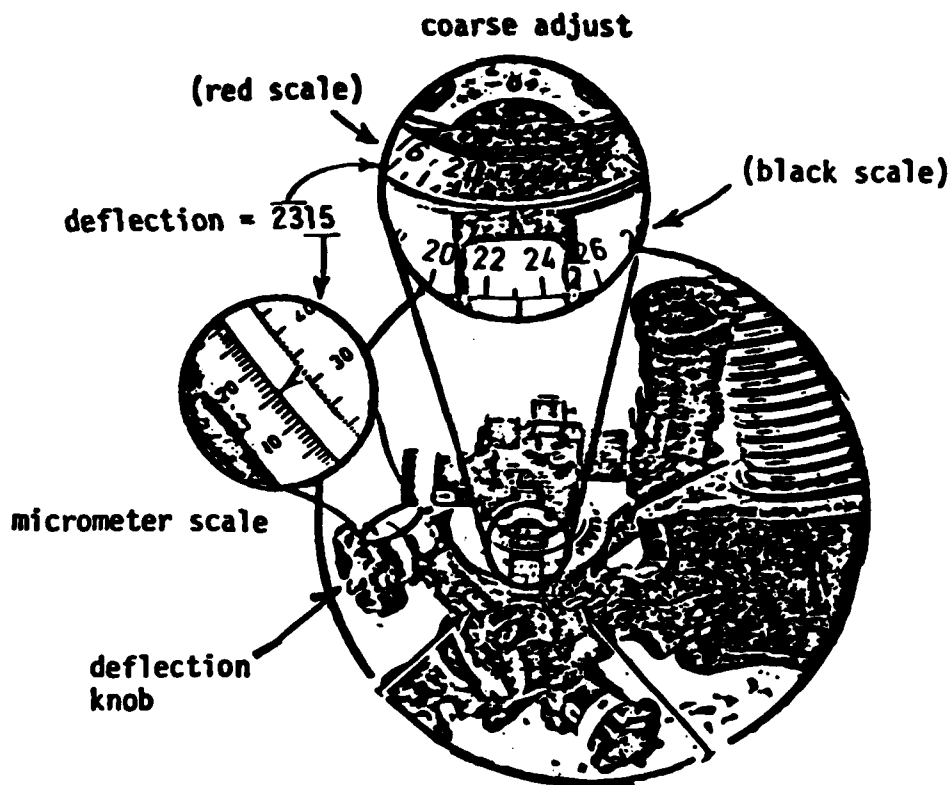

Figure 5-1. Subroutine for setting deflection on mortar.
(Example shows deflection setting of 2315 mils)

If these subroutines were put in the "first task" instructions rather than a special section, that task should be "reciprocal lay of the mortar." That is the core task, which uses all of the basic operations of the mortar in standard configuration. That would be rather awkward sequencing because it differs from the normal sequence of mounting the mortar first. However, that is an acceptable solution. What is unacceptable is the current situation in which each battle operation is described over and over again in various tasks, each time forcing an awkward compromise between thoroughness and brevity. The result is incomplete, disorganized task summaries, with insufficient illustrations.

Specialized concepts. Mortar gunnery also involves some specialized concepts that should be illustrated in a general section. One useful illustration would be a "configuration" showing a mortar section, the fire direction center (FDC), the forward observer (FO), and a symbol for higher command, linked in a communications net, with notes describing the kind of information sent on each link. In such illustrations, it is critical not to clutter the picture with other information. Another subroutine would show a mortar from above, pointing in the standard direction (3200 mils), the aiming posts (at 2800 mils), and describe how the posts are used to adjust the direction of fire.

Many mortar gunnery tasks involve using hand signals in positioning aiming posts. These are another kind of performance that should be identified as a candidate for a subroutine, which was shown in Figure 4-18. Since these signals are used in so many tasks, and in different tracks, they should be put in a section at the start of mortar gunnery, then referenced explicitly in each task where they are used.

We should not open the floodgates to all sorts of vague, irrelevant trivia in various introductory sections. But the danger of that seems minimal if the task summaries are written first, and every subroutine is justified on the basis of specific concepts and operations needed in several tasks.

Mortar gunnery tasks involve an exceptional number of subroutines that should be trained "up front." That is why it is was discussed as an example. Most tasks are more like "zeroing the M203," in that they involve few if any considerations that affect sequencing of other task instructions, or the coverage in other sections of the manual.

Combining tasks. Another way to reduce redundancy between task summaries is to combine them. We have been assuming that task listing is fixed but suggestions for changes may be welcomed. Learning the job is generally easier if similar task summaries are combined. This not only avoids repetition, but eliminates the need for comparing task summaries for similarities and differences. You should also be alert for "tasks" that are too small to be significant, or too global to be described rigorously.

Trainer's Notes

You should also review your draft and the various "input" information you have been collecting to determine what arrangements should be made by the trainers for practicing the task. For instance, firing ranges require schedules, and ammunition must be requisitioned well in advance. There will be trainer's notes at the front of the level one manual, in higher level manuals if needed, and at the beginning of various sections, depending on the need in each MOS. Determine where each kind of planning information

should go in the manual. If someone else is writing that section, coordinate with them so that the information may appear in the intended place. Occasionally, trainers may need information that is unique to a particular task, and that should be in a section entitled "Trainer's Notes" at the end of the instructions for the task.

FEEDBACK

You will be submitting your draft task summary to others to get various kinds of feedback information. The techniques you use, and the kinds of information you get, will depend upon the kind of person you approach. But whoever it is, adopt attitudes of accepting criticism, and even encourage it. The first time a person points out a flaw, reinforce that behavior. Listen carefully, be sure you understand what was said, and express appreciation with a statement such as "Ah! That's the kind of thing we're trying to correct." If the person says something like "It's probably just me. I guess nobody else would look at it that way." You should reply, "No, if you were misled, someone else is going to see it the same way." It is like fishing for criticism. Later you can sort it out in deciding how to apply it.

Your skill in drafting the task summary will now pay off. It is much easier to correct a draft that is well organized, simply worded, and clearly illustrated, than to correct one that is chaotic, wordy, obtuse, and poorly illustrated. Imagine trying out the revised instructions for the M203 with someone and compare that with your expectations with trying out the original. You will probably be convinced that it would be easier to detect the remaining flaws in the revision, than to detect all the flaws in the original.

You apply three criteria in getting feedback: effectiveness, accuracy, and acceptability. Each has its own characteristic method of determination.

EFFECTIVENESS

The primary method of determining effectiveness is to see whether a novice can do the task from only your printed instructions. Each novice should be like the soldiers who will use the instructions. But it is better to find a novice who is underqualified than overqualified. As the novice tries to follow your printed instructions, be alert even for hesitations, which are a far more sensitive indication of ambiguity than overt errors. If you see any hesitation, "fish" for the ambiguity that caused it.

Sometimes it will not be feasible to try out your draft with soldiers using it to perform the task. Then have novices act out the performance in the best feasible simulation, following your draft task summary.

After trying your task summary with two or three soldiers, you will probably find some things to correct. Repeat the tryouts and corrections with several soldiers. When about six soldiers can perform the task from your instructions, you probably have found almost all of the ambiguities. The point of diminishing returns depends upon the task and your sensitivity in probing for confusions. It would probably be counterproductive to require a particular number of tryouts, because it would be easy to conduct half-hearted and ineffective trials. But remember how much time and effort you saved by writing your first draft quickly, and apply some of it in tryouts and revisions.

"Experts" may review your draft and criticize your wording or illustrations. But their criticism is suspect because it is very difficult for them to imagine how a novice might see things. An expert will often say something like "I see what you mean, but..." and then suggest adding all sorts of needless detail to make things "perfectly clear." A review by a novice is better, but still somewhat suspect if he is not actually performing the task from your instructions. However, a simple review is much better than no information at all, and sometimes it is the only feasible method.

ACCURACY

"Expert" review is useful for detecting inaccuracy. Ask the subject matter expert about the reason for his judgment. Try to determine whether each criticism is based upon fact, or opinion about effectiveness. Be receptive to opinions of any sort, but use your judgment in evaluating them.

You may also observe some people performing the task on the job, to see whether your task summary corresponds with the way they do it. You may also show your draft to them and their supervisors, and ask whether it describes what they do.

ACCEPTABILITY

Sooner or later you will have to submit your task instructions to someone in authority for review. They may suggest changes, insist on changes, or even reject the whole package. In the model for developing instructions (Figure 3-1), there is a two-way arrow between "FEEDBACK" and "TASK PERFORMANCE INSTRUCTIONS," indicating that someone in authority may change the instructions directly, bypassing the normal route which goes through task analysis. However, your chances of passing over this hurdle are much better if your task instructions are accurate and effective, and if you have data to prove it.

Chapter 6

NOTES FOR TRAINERS

The new series of Soldier's Manuals will include notes for trainers, which used to be published separately as the Commander's Manual. These notes should describe instructional strategies that are appropriate for various kinds of tasks. They may appear at the beginning of related groups of task summaries; you should try to be specific without being repetitive. Instructor notes may also contain suggestions about training administration (e.g., lists of equipment needed for particular exercises), but this chapter is concerned specifically with instructional strategies. The discussion is only suggestive, not exhaustive.

PRACTICE CONDITIONS

Tasks vary considerably in the amount of equipment needed for practice, and the difficulty of making arrangements for training periods. Those circumstances are the basis for four task categories, as follows.

Pictorial Simulation Appropriate

For these kinds of tasks, simple simulation (e.g., pictures or simple equipment) are effective for at least some of the practice. These tasks usually do not involve much "intrinsic feedback" (i.e., a soldier may forget to do something or make a mistake without discovering it).

No special equipment needed. Some tasks may be practiced without special equipment. For instance, probing for mines can be practiced with only a crude stick, which could be simulated with a pencil. A trainer should be ready to train such tasks at various odd moments, to make best use of the time available.

Equipment needed for some practice. For other tasks, simple simulation is useful, but not sufficient for all practice. For example, a soldier can describe most procedures on a mortar using only pictures of the mortar, as a supervisor checks his description of performance. Better still, the same method can be used in garrison with a mortar, without having to go to the field. From such exercises, a soldier can learn procedural steps, including many specific values involved. The soldier will also need practice with the equipment in the field. But that practice will go much faster if the soldier already has been checked out on the basics in garrison.

Equipment Required For All Practice

With other kinds of tasks, the real equipment (or a high fidelity simulator) is needed for all (or almost all) of the practice.

Simple practice situation. For this group of tasks, the equipment is needed for practice, but it is easy to obtain, and practice conditions are simple. For example, for

assembly and disassembly of individual weapons, no pictures or simple simulator are effective for practice, but that is of little concern because the equipment is readily available. There is a high degree of intrinsic feedback in tasks of this sort, so a soldier could not make mistakes or forget something without discovering it. Task performance tends to depend heavily upon "feel" of the weapon (or other machine). This kind of task performance is not so easily forgotten as more verbal tasks, which generally involve values that seem arbitrary, more or less.

Difficult practice arrangements. Other tasks can only be practiced on the equipment, and practice conditions are difficult to arrange. That includes any live firing exercise. A trainer can better concentrate on arrangements for practicing such tasks if arrangements for other tasks are simplified.

FUNCTIONS OF THE TRAINER

The methods discussed in this manual imply a shift in the functions to be performed by trainers.

Instructions For Task Performance

If you develop effective task summaries for the Soldier's Manuals, the trainer should not have to explain how to do each task.

Practice/Testing

Your task summaries will not only be a guide during practice, but will also serve as a check sheet for scoring performance. That is a form of "diagnostic" testing, which determines the need for further practice, and tells the soldier specifically what he needs to correct.

Some of the practice/testing will be administered by the immediate supervisor, using your task instructions for checking performance. The trainer may also tell the soldier to practice as another soldier checks performance, until the standard is met. Then the trainer may check again. Such practice/testing puts a premium on clarity of instructions.

Administration of Training

Such practice/testing makes it much easier to keep track of which soldiers have mastered each task at squad, company, and battalion levels.

PRINTED CRITERIA FOR UNIT EXERCISES

The trainer's notes should also discuss the need for printed performance criteria, disseminated to trainers before major exercises. For example, if a battalion is practicing an active defense mission in preparation for ARTEP, trainers at various levels should

discuss with their troops the criteria by which their performance will be judged. Some examples of those criteria are: (1) every weapon should be ready to fire before positions are dug in, (2) every person, squad, or higher unit should know who is the person or unit on either side, because that is who covers for him, (3) every trainer at various levels will "walk the line" during the exercise to insure that criteria are met. If such information is printed and disseminated beforehand to the various levels involved, the criteria are more likely to be met, and the remaining discrepancies can be better discussed with reference to published standards.

APPENDIX A

Table A-1. Classification of Tasks

Table A-1. Classification of Tasks

<u>Task Category</u>	<u>(Illustrative Example or Term)</u>
I. Procedures with equipment	
A. Construction	(construct a mortar position)
B. Machine operations	
1. Setup	
a. assembly & disassembly	(ground-mount a mortar)
b. zero & adjust	(zero an M203 grenade launcher)
2. Operate	
a. target engagement	
b. other normal operations	(start a tank engine)
c. immediate action	
C. Field operations	(probe for mines, or put on mask)
D. Maintenance	
1. Preventive	
a. inspect & adjust	
b. lubricate, treat surface	
c. assembly, disassembly	
2. Corrective	
a. diagnosis	(electronic troubleshooting)
b. using test equipment (measure voltage with multimeter)	
c. repair	
(1) replace components	
(2) fix old components	
II. Procedures with data	
A. Graphics	
1. Read plot	(map reading)
2. Make plot	(use plotting board)
B. Composition	
1. Make simple entries	(fill out DA Form 2408-14)
2. Follow format	(prepare indorsement)
3. Plan	(prepare Operations Order)
C. Calculation	
1. Use tables	(use log tables)
2. Write computations	(algebraic problems)
3. Use ADP systems	(operate BETA terminal)
III. Component skills	
A. Identification	
1. Equipment	(combat vehicle identification)
2. Concept formation	(diagnosis of immersion foot)
B. Decision making	(react to flares)
C. Communication skills	
1. Voice communication	(transmit a radio message)
2. Use hand signals, or mechanical	(hand signals, for aiming stakes)
3. Use job aids	(use "lube orders")
D. Prohibitions	(warnings and cautions)
IV. Performance involving development of strength or coordination	(throwing a grenade, rifle marksmanship)
V. Criterion-driven performance (i.e., "soft skills")	(prepare & conduct performance-oriented instruction)