

AD-A134 810

PROJECT DELUGE: THE DEVELOPMENT OF A HOLLOMAN HIGH  
SPEED TEST TRACK HEAVY RAINFIELD(U) ARMAMENT DIV (AFSC)  
EGLIN AFB FL J A SHIPE 01 JUN 83 AD-TR-83-42

1/2

UNCLASSIFIED

F/G 4/2

NL



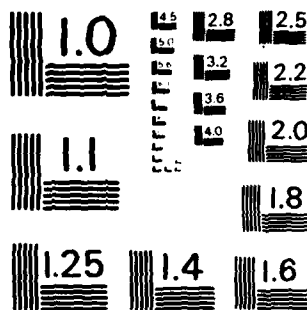

MICROCOPY RESOLUTION TEST CHART  
NATIONAL BUREAU OF STANDARDS-1963-A

12

AD-TR- 83-42

AD-A134810

FINAL REPORT

PROJECT DELUGE  
THE DEVELOPMENT OF A HOLLOMAN  
HIGH SPEED TEST TRACK HEAVY RAINFIELD

DTIC

MAJOR JOHN A. SHIPE, USAF

TEST TRACK DIVISION

6585TH TEST GROUP

HOLLOMAN AIR FORCE BASE, NEW MEXICO

NOV 19 1983  
A

FINAL REPORT FOR PERIOD JULY 1982-JUNE 1983

APPROVED FOR PUBLIC RELEASE. DISTRIBUTION UNLIMITED.

ARMAMENT DIVISION

AIR FORCE SYSTEMS COMMAND • UNITED STATES AIR FORCE



DTIC FILE COPY

83 11 17 011

UNCLASSIFIED

SECURITY CLASSIFICATION OF THIS PAGE (When Data Entered)

| REPORT DOCUMENTATION PAGE  |                                     | READ INSTRUCTIONS<br>BEFORE COMPLETING FORM                                     |
|--|-------------------------------------|---|
| 1. REPORT NUMBER<br>AD-TR-83-42  | 2. GOVT ACCESSION NO.<br>AD-A134810 | 3. RECIPIENT'S CATALOG NUMBER   |
| 4. TITLE (and Subtitle)<br>PROJECT DELUGE: The Development of a<br>Holloman High Speed Test Track Heavy<br>Rainfield   |                                     | 5. TYPE OF REPORT & PERIOD COVERED<br>FINAL                                     |
|  |                                     | 6. PERFORMING ORG. REPORT NUMBER  |
| 7. AUTHOR(s)<br>John A. Shipe, Maj., USAF  |                                     | 8. CONTRACT OR GRANT NUMBER(s)  |
| 9. PERFORMING ORGANIZATION NAME AND ADDRESS<br>6585th Test Group (AFSC)<br>Test Track Division (TK)<br>Holloman AFB, New Mexico 88330  |                                     | 10. PROGRAM ELEMENT, PROJECT, TASK<br>AREA & WORK UNIT NUMBERS<br>JON: TKGO4F01 |
| 11. CONTROLLING OFFICE NAME AND ADDRESS<br>6585th Test Group (AFSC)<br>Holloman AFB, New Mexico 88330  |                                     | 12. REPORT DATE<br>1 June 1983  |
|  |                                     | 13. NUMBER OF PAGES   |
| 14. MONITORING AGENCY NAME & ADDRESS (if different from Controlling Office)<br>6585th Test Group (AFSC)<br>Holloman AFB, New Mexico 88330  |                                     | 15. SECURITY CLASS. (of this report)<br>Unclassified                            |
|  |                                     | 15a. DECLASSIFICATION/DOWNGRADING<br>SCHEDULE<br>N/A                            |
| 16. DISTRIBUTION STATEMENT (of this Report)<br>Approved for Public Release, Distribution unlimited   |                                     |   |
| 17. DISTRIBUTION STATEMENT (of the abstract entered in Block 20, if different from Report)<br>Approved for Public Release, Distribution unlimited  |                                     |   |
| 18. SUPPLEMENTARY NOTES  |                                     |   |
| 19. KEY WORDS (Continue on reverse side if necessary and identify by block number)<br>Artificial Rainfields, Material Erosion Testing, Rain Drop<br>Distributions, Precipitation, Particle Spectrometers   |                                     |   |
| 20. ABSTRACT (Continue on reverse side if necessary and identify by block number)<br>The report describes the development of a Holloman High Speed<br>Test Track artificial rainfield with a drop mass median diameter<br>of approximately 2.7 millimeters and an accumulated rain rate of<br>20-30 inches per hour. An overview of the physical layout,<br>test set-up, and test instrumentation is given. Drop number<br>distributions over eight size categories from .3 to 5.1 milli-<br>meters are presented, as well as equivalent and accumulated rain. |                                     |   |

DD FORM 1473  
1 JAN 73

EDITION OF 1 NOV 65 IS OBSOLETE

UNCLASSIFIED

SECURITY CLASSIFICATION OF THIS PAGE (When Data Entered)

copy

UNCLASSIFIED

SECURITY CLASSIFICATION OF THIS PAGE(When Data Entered)

rate, liquid water content, and mass median diameter data. Also included are statistics for estimation of the number and size of drops encountered by a test item passing through the rainfield

## TABLE OF CONTENTS

| SECTION   | PAGE |
|---|------|
| REPORT DOCUMENTATION PAGE, DD Form 1473                 | i    |
| TABLE OF CONTENTS                                       | iii  |
| LIST OF ILLUSTRATIONS                                   | iv   |
| 1. INTRODUCTION   | 1    |
| 2. TRACK RAINFIELD CONFIGURATION                        | 1    |
| 3. INDOOR RAINFIELD CONFIGURATION                       | 2    |
| 3.1 Indoor Rainfield Construction                       | 2    |
| 3.2 DELUGE Rainfield Uniformity                         | 2    |
| 3.3 DELUGE Rainfield Configuration                      | 2    |
| 4. DATA COLLECTION                                      | 3    |
| 4.1 Measurement Grid                                    | 3    |
| 4.2 Instrumentation and Measurement Methods             | 3    |
| 4.2.1 Accumulated Rain Rate Measurements                | 3    |
| 4.2.2 Drop Size Distribution                            | 4    |
| 5. DATA ANALYSIS PROCEDURES                             | 5    |
| 5.1 IITRI Counter Errors                                | 5    |
| 5.2 Liquid Water Content                                | 5    |
| 5.3 Mass Median Diameter                                | 7    |
| 5.4 Equivalent Rain Rate                                | 7    |
| 5.5 Exponential Approximation to Drop Size Distribution | 8    |
| 5.6 Estimated Number of Drops Encountered by a Target   | 8    |
| 6. DELUGE RAIN RATE                                     | 9    |
| 6.1 Data Summary  | 9    |
| 6.2 Number Distribution Data                            | 9    |
| 6.3 Rainfield Variability                               | 10   |
| 7. CONCLUSIONS  | 11   |
| 8. RECOMMENDATIONS                                      | 11   |
| REFERENCES  | 13   |
| APPENDIX A Nuances of the IITRI Counter                 | A-1  |
| APPENDIX B DELUGE Analysis Program Listing              | B-1  |
| APPENDIX C Ten Second IITRI Counter Data                | C-1  |



Accession

NTIS GRA&I

DTIC TAB

Unannounced

Justification

Distribution/

Availability

for

AH

## LIST OF ILLUSTRATIONS

| FIGURE |   | PAGE |
|--------|---|------|
| 1      | View of Indoor Rainfield with IITRI Counter                         | 14   |
| 2      | Side View, Project DELUGE Sampling Grid                             | 15   |
| 3      | Top View, Project DELUGE Sampling Grid                              | 15   |
| 4      | Cross Section, Project DELUGE Sampling Grid                         | 17   |
| 5      | View of IITRI Counter   | 18   |
| 6      | DELUGE Rainfield Raindrops  | 19   |
| 7      | Project DELUGE Row Averaged Rainfield Parameters                    | 20   |
| 8      | Rainfield Drop Concentration Statistics                             | 21   |
| 9      | Row 1, Drop Density vs Drop Size                                    | 22   |
| 10     | Row 2, Drop Density vs Drop Size                                    | 23   |
| 11     | Row 3, Drop Density vs Drop Size                                    | 24   |
| 12     | Row 4, Drop Density vs Drop Size                                    | 25   |
| 13     | Row 5, Drop Density vs Drop Size                                    | 26   |
| 14     | Row 6, Drop Density vs Drop Size                                    | 27   |
| 15     | Row 7, Drop Density vs Drop Size                                    | 28   |
| 16     | Row 8, Drop Density vs Drop Size                                    | 29   |
| 17     | Row 9, Drop Density vs Drop Size                                    | 30   |
| 18     | Sample Locations 1-9,<br>Average Drop Density vs Sample Locations   | 31   |
| 19     | Sample Locations 10-18,<br>Average Drop Density vs Sample Locations | 32   |
| 20     | Sample Locations 19-27,<br>Average Drop Density vs Sample Locations | 33   |
| 21     | Sample Locations 28-36,<br>Average Drop Density vs Sample Locations | 34   |
| 22     | Sample Locations 37-45,<br>Average Drop Density vs Sample Locations | 35   |
| 23     | Sample Locations 46-54,<br>Average Drop Density vs Sample Locations | 36   |
| 24     | Sample Locations 55-63,<br>Average Drop Density vs Sample Locations | 37   |
| 25     | Sample Locations 64-72,<br>Average Drop Density vs Sample Locations | 38   |
| 26     | Sample Locations 73-81,<br>Average Drop Density vs Sample Locations | 39   |
| 27     | LWC, MMD, and Rain Rate, Sample Locations 1-9                       | 40   |
| 28     | LWC, MMD, and Rain Rate, Sample Locations 10-18                     | 41   |
| 29     | LWC, MMD, and Rain Rate, Sample Locations 19-27                     | 42   |
| 30     | LWC, MMD, and Rain Rate, Sample Locations 28-36                     | 43   |
| 31     | LWC, MMD, and Rain Rate, Sample Locations 37-45                     | 44   |
| 32     | LWC, MMD, and Rain Rate, Sample Locations 46-54                     | 45   |
| 33     | LWC, MMD, and Rain Rate, Sample Locations 55-63                     | 46   |
| 34     | LWC, MMD, and Rain Rate, Sample Locations 64-72                     | 47   |
| 35     | LWC, MMD, and Rain Rate, Sample Locations 73-81                     | 48   |

## PROJECT DELUGE

### The Development of a Holloman High Speed Test Track Heavy Rainfield

#### 1. INTRODUCTION

The U S Army Artillery Research and Development Command (ARRADCOM) Dover, New Jersey, established a requirement for a High Speed Test Track rainfield with a rain accumulation rate of 20-30 inches per hour and a distribution with a mass median diameter of approximately 2.8 millimeters.\*

An artificial rainfield meeting these rain rate and mass median diameter criteria simultaneously had never been achieved on the present Track facility. As a result, Project DELUGE was instituted. The objectives of the project were:

Construct an indoor rainfield calibration and characterization facility that can reproduce no-wind track artificial rainfield conditions.

Develop a rainfield that can produce the accumulation rate and mass median drop diameter requested by ARRADCOM.

Characterize the variability of the ARRADCOM rainfield with respect to accumulated rainfall rate, mass median diameter, and other rainfield parameters.

This report describes how each of these objectives were met.

#### 2. TRACK RAINFIELD CONFIGURATION

The Track rainfield has a maximum operational length of 8000 feet, divided into 400 foot long spraying sectors. The water pressure and flow rate can be controlled within each sector. The sectors in turn are made up of 20 foot long sections of two 4" diameter manifold pipes mounted side by side. The water spray distribution is achieved via nozzles placed on risers of 69 and 84 inches in height mounted eight feet apart on each manifold. The 69 inch (low riser) manifolds and 84 inch (high riser) manifolds are arranged so the distance between successive risers is four feet. The standard nozzle angles are 18 degrees from the vertical for the high risers, 23 degrees for the low risers.

When the track rainfield is configured in this manner, the spray pattern repeats itself every eight feet. Reference 1 Appendix A gives further details of the Track Artificial Rainfield layout.

---

\*These specifications came from a fuze test on the ballistics rainfield in the late 60's, described in reference 4.



### 3. INDOOR RAINFIELD CONFIGURATION

#### 3.1 Indoor Rainfield Construction

Characterization of the Track Rainfield along the track has several inherent difficulties. These include scheduling around sled runs and working outside in the elements. The biggest problem, however, is that winds cause a spread of the test data and mask variability caused by nozzle configuration and pressure changes. An indoor facility does not have these difficulties. As a result, one was constructed in the bay of building 1179 and is pictured in figure 1.

It is constructed of a standard 20 foot track rainfield section made up of two 4 inch manifolds, one equipped with two high risers, the other with three low risers. Together they form a system of 4 foot spaced alternating high and low risers. Water pressure is controlled by gate valves and measured by two dial gauges mounted atop the risers, as is done on the track rainfield.

#### 3.2 DELUGE Rainfield Uniformity

It is not possible to produce a uniform rainfield from a line of nozzles with a cone shaped spray pattern. A side view of the most uniform pattern which met the DELUGE rainfield parameter requirements is shown below.



In it, the edge of the spray cones just touch one another at the sled centerline (17 inches above and centered over the rail).

It was found that the drop pattern is not uniform within the cone. The larger drops and heavier rain rates tend to be on the edge of the cone. Overlapping the patterns, which would help solve this problem, was not possible due to the large amount of water required. As a result, the point to point variability of the DELUGE rainfield is fairly large. The variability was measured as part of the Project and is described in paragraph 6.3

#### 3.3 DELUGE Rainfield Configuration.

Several nozzles, water pressures, and rainfield configurations were evaluated looking for a set up that would meet the ARRADCOM requirements. Several would, but given limited water availability and a desire to keep the rainfield as

standard and uniform as possible, the following configuration was selected:

Nozzle: Spraying System Co 310-3/4H7 adjustable nozzle.  
The adjustable cap should be set two full turns  
out from fully retracted.

Pressures: 2.5 psi on high risers  
(nozzle) 3.25 psi on low risers

Angles: high risers-18 degrees from vertical  
low risers - 23 degrees from vertical

#### 4. DATA COLLECTION

##### 4.1 Measurement Grid.

Ehni (ref 1) conducted a similar rainfield data gathering program in 1973. They set up a three dimensional grid of measurement points over an eight foot rainfield section. They found that a horizontal spacing between grid points of one foot produced good data with stable means and standard deviations. As a result, project DELUGE adopted this horizontal grid spacing. Vertical grid spacing was determined by the characteristics of the rocket sled used for the ARRADCOM test. Its centerline was 17 inches above the top of the track rail with test items mounted nine inches above, below, and on either side of the centerline. Therefore, a 9 X 3 X 3 three dimensional measurement grid was adopted, 8 feet long, 18 inches wide and 18 inches high centered on the ARRADCOM rocket sled centerline. The grid is shown in figures 2, 3, and 4.

Since the DELUGE rainfield is not uniform, the overall conditions that a test article will experience passing through the rainfield is dependent on its position in the rainfield. To provide data representative of conditions experienced by a test article, most of the data analyzed in this report were combined into row averages along the nine rows shown in figure 4.

##### 4.2 Instrumentation and Measurement Methods.

###### 4.2.1 Accumulated Rain Rate Measurements.

Accumulation rate measurements were made with "TRU-Check" plastic raingauges manufactured by Edwards Mfg. Co. The raingauge opening, measuring 2.5" X 2.25", was centered on the grid point. The rainfield was stabilized, and six minutes of rain accumulation was measured.

#### 4.2.2. Drop Size Distribution.

Drop size distribution measurements were made with an "IITRI Counter" particle spectrometer developed for the Test Track in the late 60's by the IIT Research Institute.

It consists of a Zenon flash tube, optics to produce a collimated light beam and an optical receiver. The flash tube pulses 7.5 times a second and illuminates a volume through which rain drops are falling. The sample volume is given by

$$V = 7.5ABT$$

where A is the cross sectional area of the collimated beam (26.1 cm<sup>2</sup>), B is the opening of an adjustable hood (Project Deluge used 7.6 cm), and T is total sample time in seconds.

The rain drops refract the collimated light beam and are sensed by the optical receiver, which has a TV-type raster scan. Theoretically, up to 20 drops can be counted on one scan. A raindrop's size is estimated by electronics in a video console which counts the number of rasters it intercepts. The drops are then categorized with respect to size and accumulated in eight bins. In this set-up, the bins were .6mm wide and ranged from .3 to 5.1 mm.

References 5 and 7 give further details on the IITRI counter. Figure 5 shows the IITRI counter. The drops are sampled at the opening in the center. The green fiber packing material covering the counter reduces splash effects.

The counter was calibrated twice a day during Project DELUGE. Calibration was accomplished by putting a glass slide with two black dots of known diameter (1.14 and 3.72 mm) printed on it into the sample volume. Several ten second calibration runs were made. The counter's focus and intensity controls were adjusted until the size ranges sensed and the total number counted were correct and repeated for at least six calibration runs.

To take data, the IITRI was set with the sample volume centered on a grid point, the rainfield was stabilized with respect to nozzle pressure, and the data taken. Two types of data were taken, each on separate days. One was a single 300 second data sample, the other was about 25 sets of 10 second data samples.

In general, the IITRI counter worked well. However, it has some quirks which can affect the data. Several of those noted during Project DELUGE are given in Appendix A.

## 5. DATA ANALYSIS PROCEDURES

### 5.1 IITRI Counter Errors

Several parameters, like total liquid water content and drop mass median diameter, were derived from number distribution data. The derivations assume that the drops are spherical. To determine if the rainfield drops were spherical, polaroid pictures of the IITRI videocon flashtube display were taken. Some examples are shown in Figure 6. Camera settings were .1 sec exposure, F4.7 opening. In general, the drops were indeed close to being spherical. However, the larger drops sometimes appear irregularly shaped, as the circled drop shows. This drop is probably an example of a type B error, as described below.

The IITRI counter introduces certain errors into the drop counts distribution. These include:

a. Drops shadowed partially or completely by other drops located along the same line of sight.

b. Drops located so close to other drops along scan lines that the logic system does not differentiate between them and counts two nearby drops as one large drop.

c. Drops intersected by the edges of the viewing window. If these drops have less than 1/2 of their cross section within the window, they are registered in a smaller drop size category.

The probability of type a. and type b. errors can be kept small as long as the drop density is reasonably limited by adjusting the IITRI hood opening. Details are given in Appendix A. Type c. errors were corrected using an algorithm suggested by IITRI. Ref 1 describes it in detail. The algorithm was incorporated in the analysis computer program given in Appendix B and applied to all data before further processing.

### 5.2 Liquid Water Content (LWC)

The standard method for computing the liquid water content of a drop number distribution is to simply compute the liquid water mass per unit volume in each size category and add them up:

$$LWC = \sum_I M_i$$

A drop diameter representative of the size interval, usually the mid point, is used to compute the mass. The implicit assumption in this procedure is that the drops are uniformly distributed within the size interval. It has been found that the number distributions of both natural and Track rainfields closely approximate exponential distributions. As a

result, significant overestimates of LWC can be made. This is particularly true when the size intervals are as wide as those of the IITRI Counter. The following algorithm, which assumes an exponential rather than uniform number distribution, was developed to alleviate this problem.

The liquid water content of drop size interval I from D1 to D2 is given by:

$$LWC_I = K \pi/6 \int_{D_1}^{D_2} D^3 N(D) dD$$

where

D = Drop Diameter

K = constant

N(D) = Drop Distribution

a. Assume:  $\ln N(D) = MD + B$

or  $N(D) = e^{MD} e^B$

Then  $LWC_I = K \pi/6 e^B \int_{D_1}^{D_2} e^{MD} D^3 dD$

$$LWC_I = K \pi/6 e^B \left[ \frac{D^3 e^{MD}}{M} - \frac{3D^2 e^{MD}}{M^2} + \frac{6De^{MD}}{M^3} - \frac{6e^{MD}}{M^4} \right]_{D_1}^{D_2}$$

b. The Slope of the Distribution within size interval I is given by:

$$M = \frac{\ln N_{I+1} - \ln N_{I-1}}{D_{I+1} - D_{I-1}}$$

c. Compute the Y intercept by noting that:

$$\int_{D_1}^{D_2} N(D) dD = N_I = e^B \int_{D_1}^{D_2} e^{MD} dD$$

$$N_I = e^B / M (e^{MD_2} - e^{MD_1})$$

$$B = \ln \left( \frac{M N_I}{e^{MD_2} - e^{MD_1}} \right)$$

The above expressions for M and B are substituted in the LWC expression. For a drop diameter in millimeters and LWC in grams per cubic meter,  $K = .001$ . The total liquid water content of the distribution is:

$$LWC_{Tot} = \sum_{i=1}^8 LWC_I$$

### 5.3 Mass Median Diameter (MMD).

The drop diameter which divides the total liquid water content two equal parts. This is a derived term. Units are millimeters.

$$MMD = \frac{D_j + \Delta D/2 + \Delta D(50 - \text{percent}_j)}{(\text{percent}_{j+1} - \text{percent}_j)}$$

where:  $j$  = largest size interval with an accumulated LWC less than 50% of the total LWC.

$D$  = size interval mid point diameter

$\Delta D$  = size interval width (.6 mm)

Percent = accumulated percent of total LWC

### 5.4 Equivalent Rain Rate (ERR).

The rain rate that would result if the measured drop distribution were found in nature. This is computed by multiplying the LWC in each size category by a representative fall velocity and summing over the distribution.

The Gunn and Kinzer (ref 3) fall velocity as a function of drop diameter relationship, as approximated by the following power series, was used in Project DELUCE.

$$V_I = C_0 + C_1 D_I + C_2 D_I^2 + C_3 D_I^3 + C_4 D_I^4$$

$$C_0 = -.27128$$

$$C_1 = -5.22306$$

$$C_2 = +1.10757$$

$$C_3 = +.11115$$

$$C_4 = -.0046884$$

Where the units of  $V_i$  are M/sec and  $D_i$  mm. If LWC is given in g/M<sup>3</sup> and ERR in inches/hr is required,  $k=.142$

The ERR of artificial rainfields is usually different from that measured by raingauges because drops are usually falling at a rate different from their terminal velocity. The number should not be used by itself to characterize the rainfield. Different drop distributions, producing different effects on a test specimen, can have similar equivalent rain rates. What ERR does provide is a physically tenable connection between a

rainfield distribution and a commonly measured natural rainfall parameter.

### 5.5 Exponential Approximation to Drop Size Distribution

Marshall and Palmer (ref 6) and other researchers have approximated the drop size distribution of natural rain with an exponential fit of the form

$$N = A \cdot \text{EXP}(-D_i/B)$$

On semi-log paper, this plots as a straight line with A the Y intercept and a slope of  $-1/B$ . These numbers (A and B) were computed for DELUGE number distributions using least squares curve fit methods.

### 5.6 Estimated Number of Drops Encountered by a Target.

During testing of an item on the rainfield, it is often important to know how many drops within a specified size range it can expect to encounter while traveling through a given length of rainfield. To estimate this, approximately 25 ten second number distribution data samples were taken at each grid point, the data combined into the nine rows, and means and standard deviations for each row computed. Following the methods of Ehni (ref 1), the average number drops encountered in size interval I is proportional to the volume  $V_r$  of the rainfield swept out by a test item.

$$\bar{X}_{IVr} = \frac{V_r}{V_s} \bar{X}_{IVs}$$

where  $V_s$  stands for the IITRI Counter sample volume. For a 10 second IITRI Counter sample with the hood opening of 7.62 cm, the sample cross sectional area of 26.1 cm<sup>2</sup>, and 9 sample locations per row,

$$V_s = \frac{7.5 \text{ exp}}{3 \text{ sec}} * 7.62 \text{ cm} * 26.1 \text{ cm}^2 * \frac{10 \text{ sec}}{\text{sample}} * \frac{9 \text{ samples}}{\text{row}}$$

$$V_s = 1.24 * 10^5 \text{ cm}^3$$

The standard deviation  $S$  is proportional to the square root of the volume swept out

$$S_{Vr} = (V_r/V_s)^{1/2} S_{Vs}$$

The DELUGE mean and standard deviation statistics were normalized to number of drops per cubic meter by using these relationships.

## 6. DELUGE RAIN DATA

### 6.1 Data Summary.

Figure 7 is a summary of the row averaged rainfield parameters derived from rainfield measurements. They show that the rainfield closely approximates the ARRADCOM requirements of a 2.8mm MMD and an ARR of 20-30 inches/hour. While the rainfield is fairly uniform with respect to MMD, heavier rain rates, above the stated ARRADCOM requirements, are found in the upper and outside portions of the rainfield closest to the spray nozzles.

Actually, MMD and rain rate are not independent. Several researchers, including ref 6, have found that the natural MMD-rain rate relationship is that larger MMDs are associated with higher rain rates. The Track artificial rainfield relationship has not been thoroughly investigated. However, Ehni (ref 1) found that higher nozzle pressures, which produce higher rain rates, tend to produce smaller MMDs (more small drops and fewer large drops). The MMD-rain rate relationship should be quantified for the Track artificial rainfield.

The overall rainfield statistics, derived from these 9 row averages, are:

|     | Mean       | Std. Dev |
|-----|------------|----------|
| LWC | 27.4 g/M3  | 5.5      |
| MMD | 2.65 mm    | .08      |
| ERR | 27.4 in/hr | 5.6      |
| APR | 20.0 in/hr | 4.1      |

### 6.2 Number Distribution Data.

Figure 8 shows the row means and standard deviations of the number concentrations within each size interval. The data can be used to estimate the number of drops per cubic meter. Given the data from this table, the test item position in the rainfield, the cross sectional area of a test item, and the length of the rainfield; the number of drops encountered within a given size range can be estimated.

For instance, suppose one is interested in the number of drops encountered in the size range 2.7-3.3mm under the following conditions:

Test item cross sectional area: .01 M<sup>2</sup>

Length of rainfield: 609 M

Position of test item in rainfield: Row 1

The total volume swept out by the test item is



$$609 \cdot .01 = 6.09M^3$$

The expected number of drops to be encountered is

$$6.09M^3 \cdot 263 \text{ drops}/M^3 = 1602 \text{ drops}$$

The standard deviation is

$$(6.09M^3/1M^3)^{1/2} \cdot 50 \text{ drops} = 123 \text{ drops}$$

The data show that the largest number of drops are found closest to the nozzle across the top of the grid (rows 7, 8, and 9) and along the side of the grid closest to the nozzles (rows 3, 6, and 9). There is also a higher ratio of 4.5-5.1 to .3-.9mm drops in the upper rows than the lower rows (.0023 for rows 7, 8 and 9 vs .0018 for rows 1, 2, and 3). This characteristic, found by Ehni as well, indicates that the large drops are breaking up as they fall and/or the smallest drops are coalescing.

Appendix C contains a listing of the data used to prepare Figure 8.

Figures 9 through 17 are plots of normalized number concentration vs drop size for rows 1 through 9 respectively. They correspond to the row mean values in figure 8 except that a) The data are normalized by dividing them by the IITRI Counter size interval (.6 mm) to give units of #/M<sup>3</sup>/mm. b) The plots are made from averages of one 300 second sample at each location rather than approximately twenty five 10 second samples. A comparison was made between the row averages of these two sets of number distribution data. Of the 72 data points (9 rows X 8 size categories), only eight were not within +/- one standard deviation of one another. Of these eight, seven were in the .3-.9mm and .9-1.5mm size intervals. The DELUGE rainfield appears to be very repeatable under controlled test conditions, particularly in the larger size categories.

The dashed line is from the data, the solid line is the exponential curvefit to the data. A consistent pattern on each of the rows is that the rainfield has more of the largest and smallest drops than expected if the number distributions were truly exponential. However, the coefficients of determination are high: all of them were greater than .957.

### 6.3 Rainfield Variability

Figures 18 - 26 are plots of normalized drop density vs sample location. Two features of note are

- 1) The rainfield is more variable close to the nozzles (rows 7, 8, and 9)

- 2) Except where overlapping masks the effect, there tends to be fewer and smaller drops directly underneath the nozzles. In other words, the spray is rather like a hollow cone with the larger drops on the outside.

Note: There are some missing or bad data from the 300 second samples from which these plots were made: locations 33, 63, and 80. It was decided to replace the missing data with the geometrically most representative other sample: #33 was replaced by #35, #63 by #59, and #80 by #78. It was felt that this procedure would produce more representative row averages than simply ignoring the missing or bad data.

Figures 27-35 are plots of liquid water content (LWC), equivalent rain rate (ERR), accumulated rain rate (ARR), and mass median diameter (MMD) vs sample location. They show essentially the same pattern as the number distribution data but appear more variable because the plots have linear rather than logarithmic ordinates.

## 7. CONCLUSIONS

7.1 An indoor rainfield calibration facility that is a faithful reproduction of the Track rainfield has been constructed.

7.2 The indoor facility was used to develop a rainfield meeting ARRADCOM's requirements. Their requirements, an accumulated rain rate of 20-30 inches/hour and a mass median diameter of 2.8 millimeters, were met except that portions of the rainfield exceed the rain rate specification.

7.3 The point to point variability of the DELUGE rainfield has been defined.

## 8. RECOMMENDATIONS

8.1 Many researchers have found a relationship between rain rate and the number distribution (i.e. the exponential curvefit parameters A and B given in figure 7 are functions of rainrate). In order to make comparisons between the Track rainfield and natural rain, and determine if customer stated requirements are realistic, these relationships should be defined for the rainfield. This will require an extensive evaluation program since the rainfield rain rate is controlled by nozzle pressures and varies with location. The DELUGE rainfield defined here used only one set of nozzle pressures.

8.2 A comparison study should be made between the track and indoor rainfields.

8.3 A rainfield wind effects study should be made, perhaps using the indoor rainfield and fans.

## REFERENCES

1. Ehni, Friedrich P., Layout and Calibration of the Rain Simulation Facility at the Holloman Test Track, ADTC TR 75-83, 15 Nov 75.
2. Gunn, R. and Kinzer, G.D., "The Terminal Velocity of Fall of Water Droplets," Journal of Meteorology, August 1949.
3. Inca Engineering Corporation, Final Report: 400 Foot Prototype Rainfield for the AFSWC Rain Simulation Facility, December 1970.
4. Ivankoe, Eugene, Rain Sensitivity Tests on the M557 and M557E1 (XM712EZ) Point Detonating Fuzes, TR 3966, Ammunition Engineering Directorate, Picatinny Arsenal, Dover, N.J., August 1969.
5. Jackson, M.R., et al, Preliminary Design Studies for a Sled Track Rain-Simulation Facility, Vol. I, IIT Research Institute, May 1969.
6. Marshall, J.S., and Palmer, W. McK, "The Distribution of Raindrops with Size," Journal of Meteorology, May 1948.
7. Stockhan, John D., Preliminary Design Studies for a Sled-Track Rain Simulation Facility - Evaluation of a Droplet Measuring Instrument, IIT Research Institute, Jan 1968.



Figure 1  
View of Indoor Rainfield with IITRI  
Counter.

Figure 2

PROJECT DELUGE SAMPLING GRID

Side View

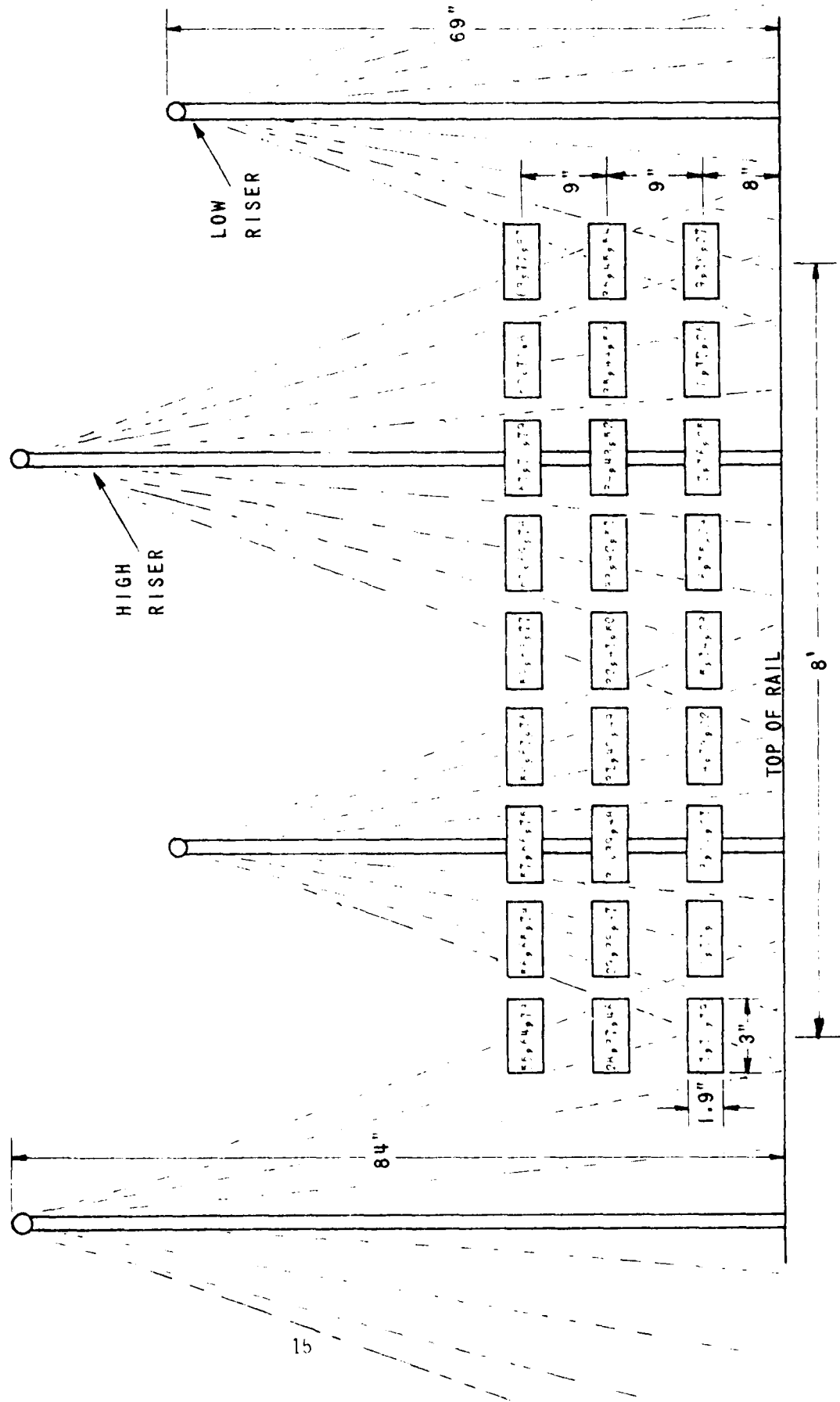

Figure 3

PROJECT DELUGE SAMPLING GRID

TOP VIEW

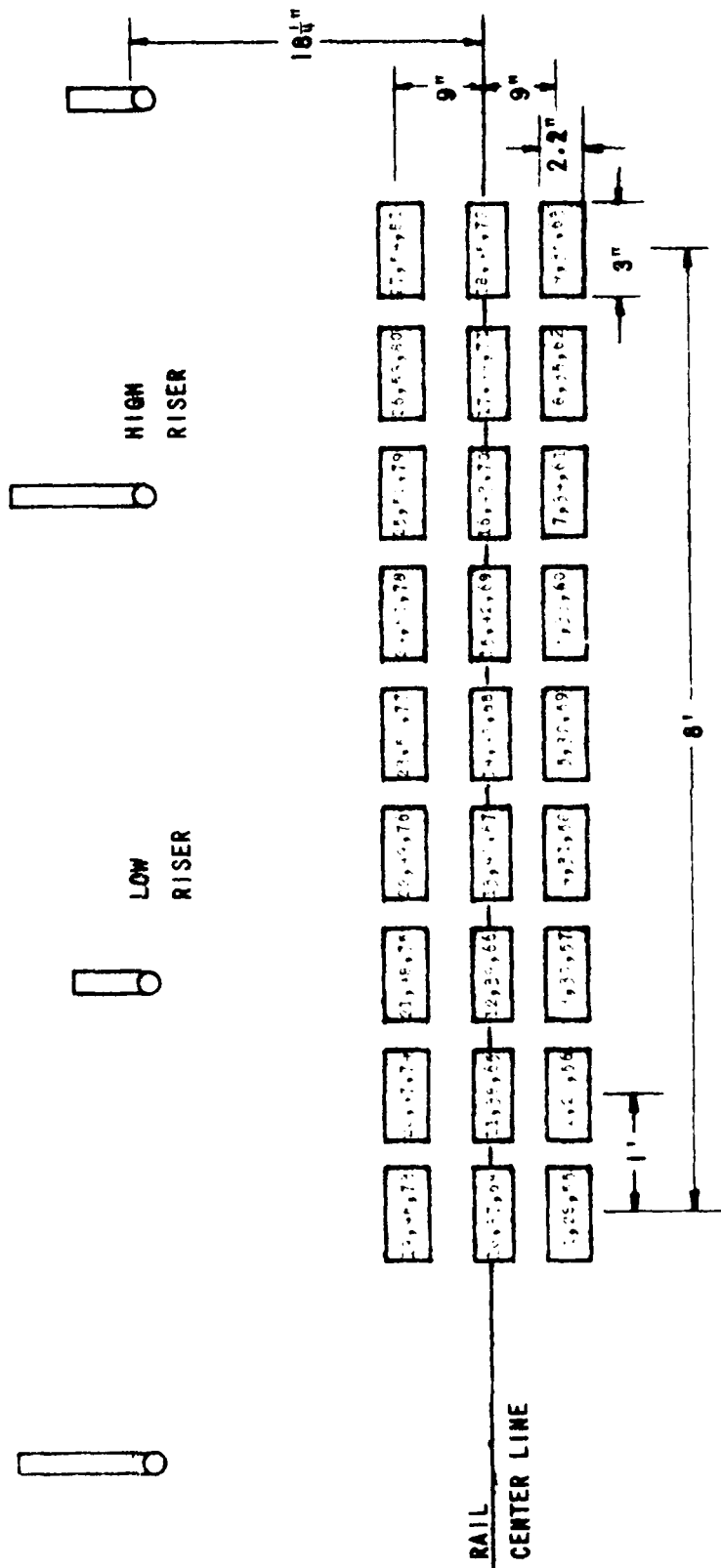

Figure 4

PROJECT DELUCE SAMPLING GRID

CROSS SECTION

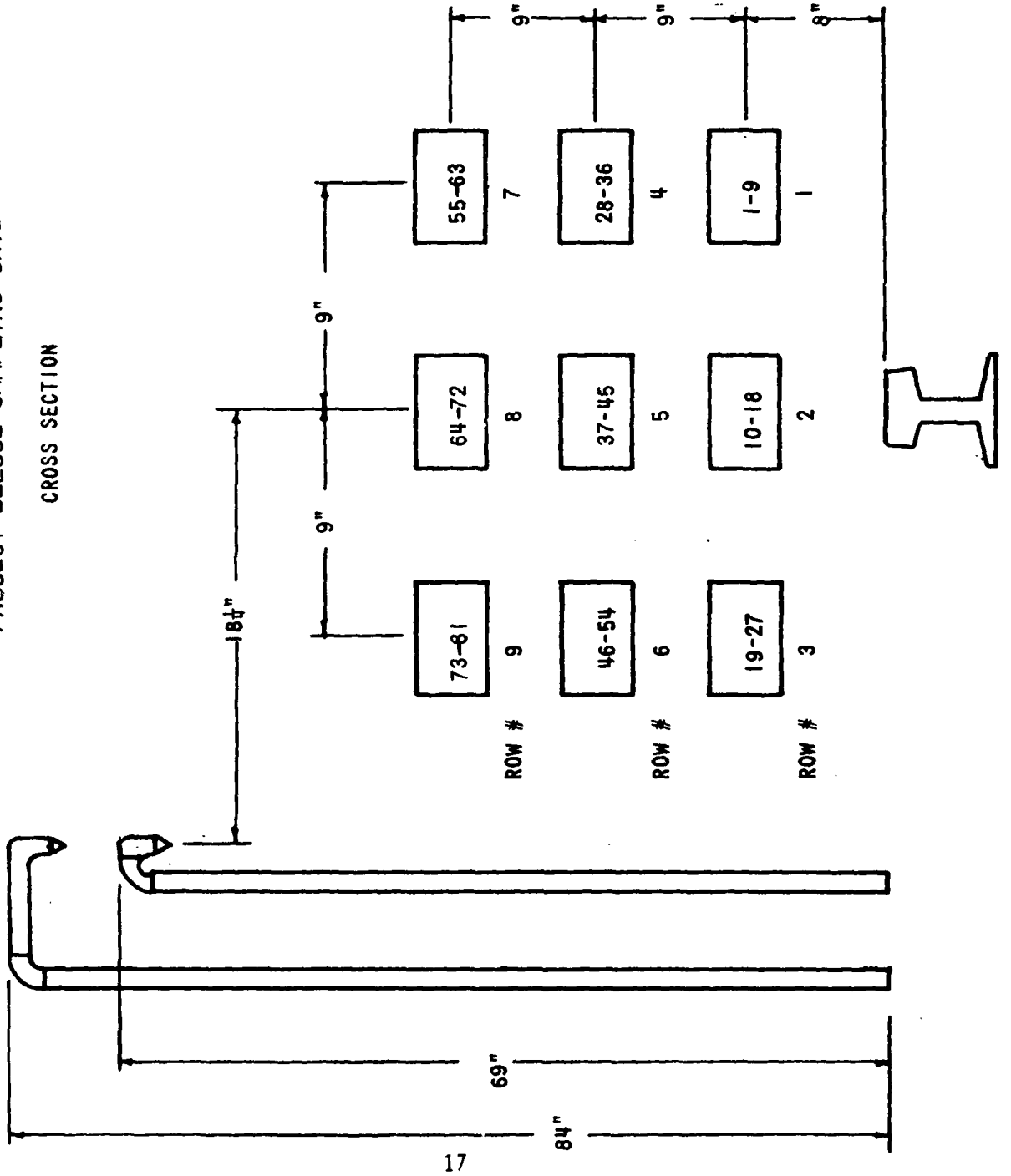





Figure 5  
View of ITRI Counter  
Page 18

Figure 6

DELUGE RAINFIELD RAINDROPS

As Seen on the IIRI Counter Video Console

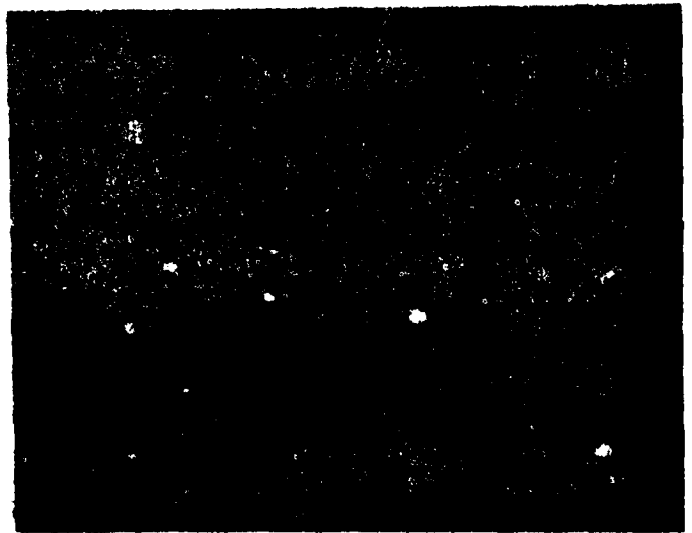
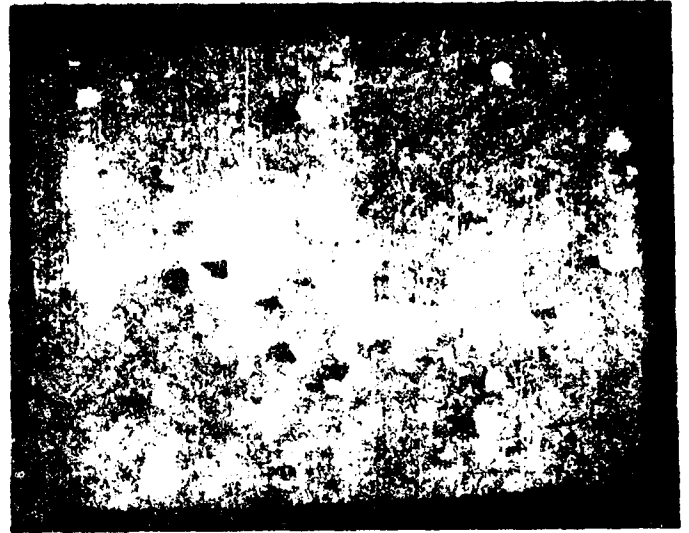
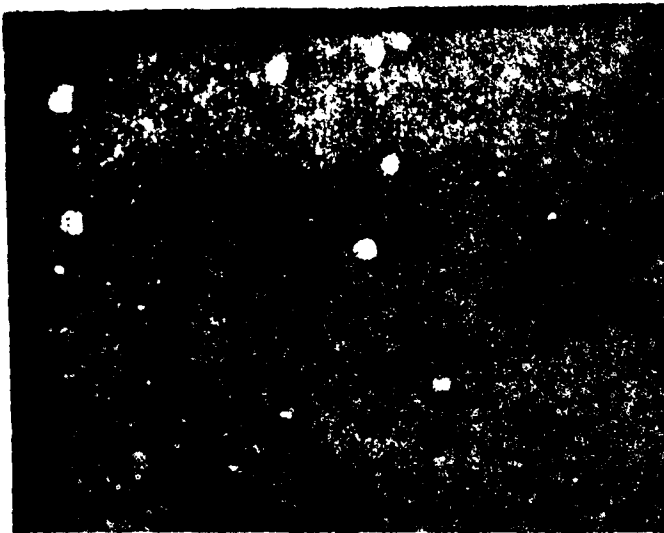

Figure 7

PROJECT DELUGE

ROW AVERAGED RAINFIELD PARAMETERS

A: 57195  
 B: .74  
 LWC: 41.0  
 MMD: 2.7  
 ERR: 41.3  
 ARR: 37.6  
Row 9

A: 45107  
 B: .72  
 LWC: 30.5  
 MMD: 2.7  
 ERR: 30.5  
 ARR: 31.4  
Row 8

A: 34542  
 B: .75  
 LWC: 26.8  
 MMD: 2.7  
 ERR: 27.2  
 ARR: 26.6  
Row 7

A: 48703  
 B: .71  
 LWC: 29.9  
 MMD: 2.6  
 ERR: 29.4  
 ARR: 33.3  
Row 6

A: 42126  
 B: .69  
 LWC: 23.5  
 MMD: 2.6  
 ERR: 23.2  
 ARR: 27.5  
Row 5

A: 34673  
 B: .73  
 LWC: 24.2  
 MMD: 2.7  
 ERR: 24.3  
 ARR: 25.4  
Row 4

A: 47179  
 B: .68  
 LWC: 25.3  
 MMD: 2.5  
 ERR: 24.7  
 ARR: 29.9  
Row 3

A: 37792  
 B: .69  
 LWC: 21.6  
 MMD: 2.6  
 ERR: 21.2  
 ARR: 26.5  
Row 2

A: 30063  
 B: .75  
 LWC: 24.4  
 MMD: 2.8  
 ERR: 24.9  
 ARR: 23.5  
Row 1

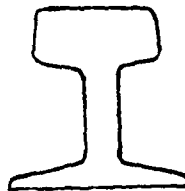

LWC: Liquid Water Content in grams per cubic meter  
 MMD: Mass Median Diameter in millimeters  
 ERR: Equivalent Rain Rate in inches per hour  
 ARR: Accumulated Rain Rate in inches per hour  
 A: Number distribution least squares fit Y-intercept (see Para. 5.5)  
 B: Number distribution least squares fit Slope Parameter  
 (Slope =  $-1/B$ , See Para. 5.5)

FIGURE 8

Rainfield Drop Concentration Statistics  
(Means, Standard Deviations)  
Normalized to #/M3

| ROW 9      |       |      | ROW 8      |       |      | ROW 7      |       |      |
|------------|-------|------|------------|-------|------|------------|-------|------|
| Size Range | X     | S.D. | Size Range | X     | S.D. | Size Range | X     | S.D. |
| .3-.9      | 29650 | 724  | .3-.9      | 21586 | 654  | .3-.9      | 16795 | 634  |
| .9-1.5     | 5850  | 257  | .9-1.5     | 4307  | 226  | .9-1.5     | 3701  | 240  |
| 1.5-2.1    | 1978  | 142  | 1.5-2.1    | 1511  | 126  | 1.5-2.1    | 1380  | 118  |
| 2.1-2.7    | 869   | 94   | 2.1-2.7    | 637   | 76   | 2.1-2.7    | 644   | 85   |
| 2.7-3.3    | 415   | 60   | 2.7-3.3    | 288   | 51   | 2.7-3.3    | 299   | 54   |
| 3.3-3.9    | 219   | 46   | 3.3-3.9    | 139   | 38   | 3.3-3.9    | 161   | 39   |
| 3.9-4.5    | 124   | 36   | 3.9-4.5    | 78    | 28   | 3.9-4.5    | 87    | 28   |
| 4.5-5.1    | 66    | 24   | 4.5-5.1    | 47    | 22   | 4.5-5.1    | 41    | 19   |

| ROW 6      |       |      | ROW 5      |       |      | ROW 4      |       |      |
|------------|-------|------|------------|-------|------|------------|-------|------|
| Size Range | X     | S.D. | Size Range | X     | S.D. | Size Range | X     | S.D. |
| .3-.9      | 24560 | 611  | .3-.9      | 20750 | 644  | .3-.9      | 16998 | 583  |
| .9-1.5     | 5107  | 233  | .9-1.5     | 3899  | 211  | .9-1.5     | 3652  | 194  |
| 1.5-2.1    | 1656  | 187  | 1.5-2.1    | 1328  | 105  | 1.5-2.1    | 1295  | 113  |
| 2.1-2.7    | 672   | 75   | 2.1-2.7    | 540   | 77   | 2.1-2.7    | 559   | 73   |
| 2.7-3.3    | 314   | 58   | 2.7-3.3    | 253   | 49   | 2.7-3.3    | 266   | 56   |
| 3.3-3.9    | 149   | 35   | 3.3-3.9    | 128   | 32   | 3.3-3.9    | 138   | 36   |
| 3.9-4.5    | 88    | 30   | 3.9-4.5    | 69    | 27   | 3.9-4.5    | 59    | 25   |
| 4.5-5.1    | 46    | 21   | 4.5-5.1    | 31    | 16   | 4.5-5.1    | 36    | 18   |

| ROW 3      |       |      | ROW 2      |       |      | ROW 1      |       |      |
|------------|-------|------|------------|-------|------|------------|-------|------|
| Size Range | X     | S.D. | Size Range | X     | S.D. | Size Range | X     | S.D. |
| .3-.9      | 23124 | 630  | .3-.9      | 19374 | 523  | .3-.9      | 16334 | 669  |
| .9-1.5     | 4325  | 208  | .9-1.5     | 3454  | 192  | .9-1.5     | 3510  | 248  |
| 1.5-2.1    | 1459  | 106  | 1.5-2.1    | 1163  | 100  | 1.5-2.1    | 1241  | 161  |
| 2.1-2.7    | 623   | 70   | 2.1-2.7    | 482   | 64   | 2.1-2.7    | 535   | 73   |
| 2.7-3.3    | 266   | 52   | 2.7-3.3    | 238   | 48   | 2.7-3.3    | 263   | 50   |
| 3.3-3.9    | 137   | 33   | 3.3-3.9    | 110   | 32   | 3.3-3.9    | 122   | 33   |
| 3.9-4.5    | 80    | 28   | 3.9-4.5    | 53    | 23   | 3.9-4.5    | 69    | 26   |
| 4.5-5.1    | 44    | 23   | 4.5-5.1    | 27    | 18   | 4.5-5.1    | 33    | 16   |

FIGURE 9

# DROP DENSITY VS DROP SIZE

SAMPLE LOCATION: 199 18000 1

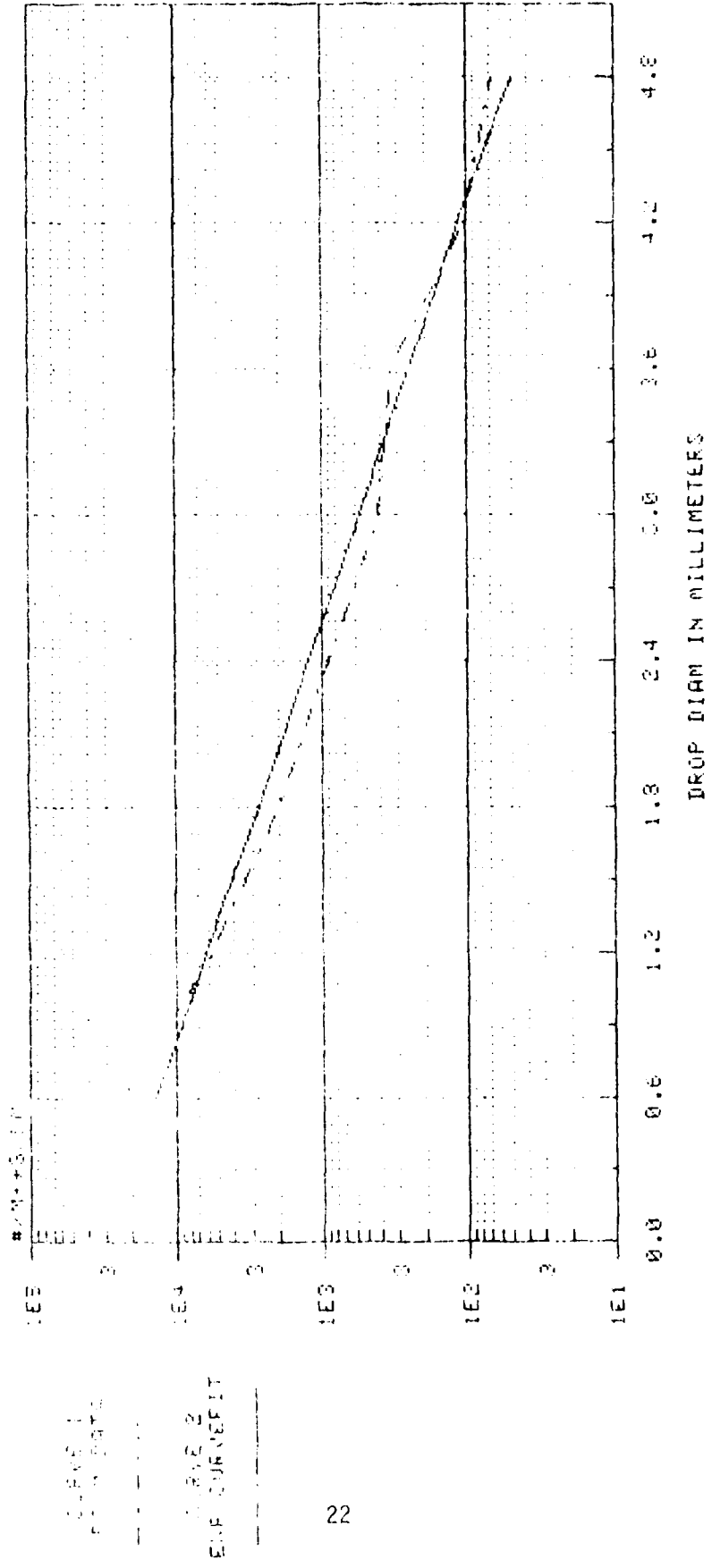

FIGURE 10

# DROP DENSITY VS DROP SIZE

SAMPLE LOCATION: 10-16 (POW 2)

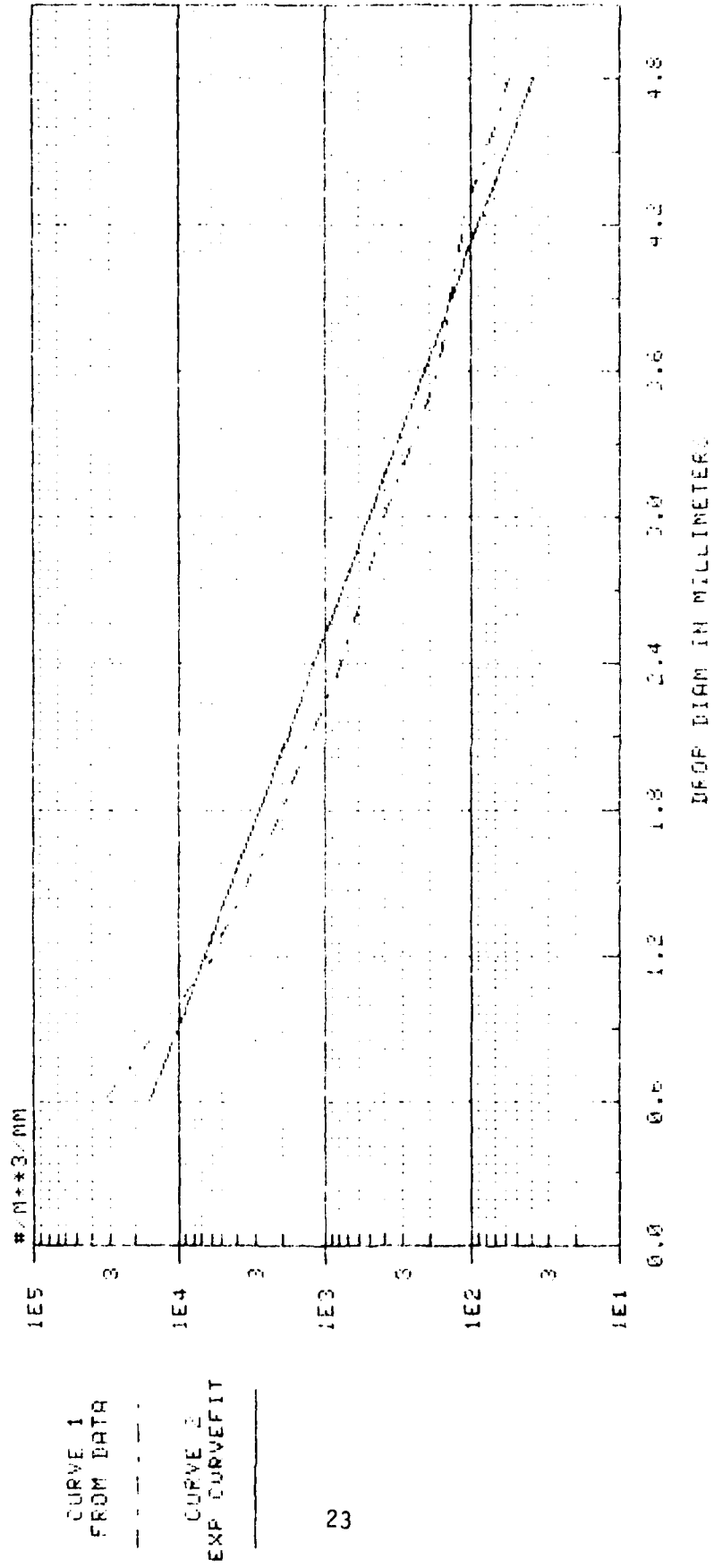

FIGURE 11

# DROP DENSITY VS DROP SIZE

TEMPERATURE 100°C (212°F)

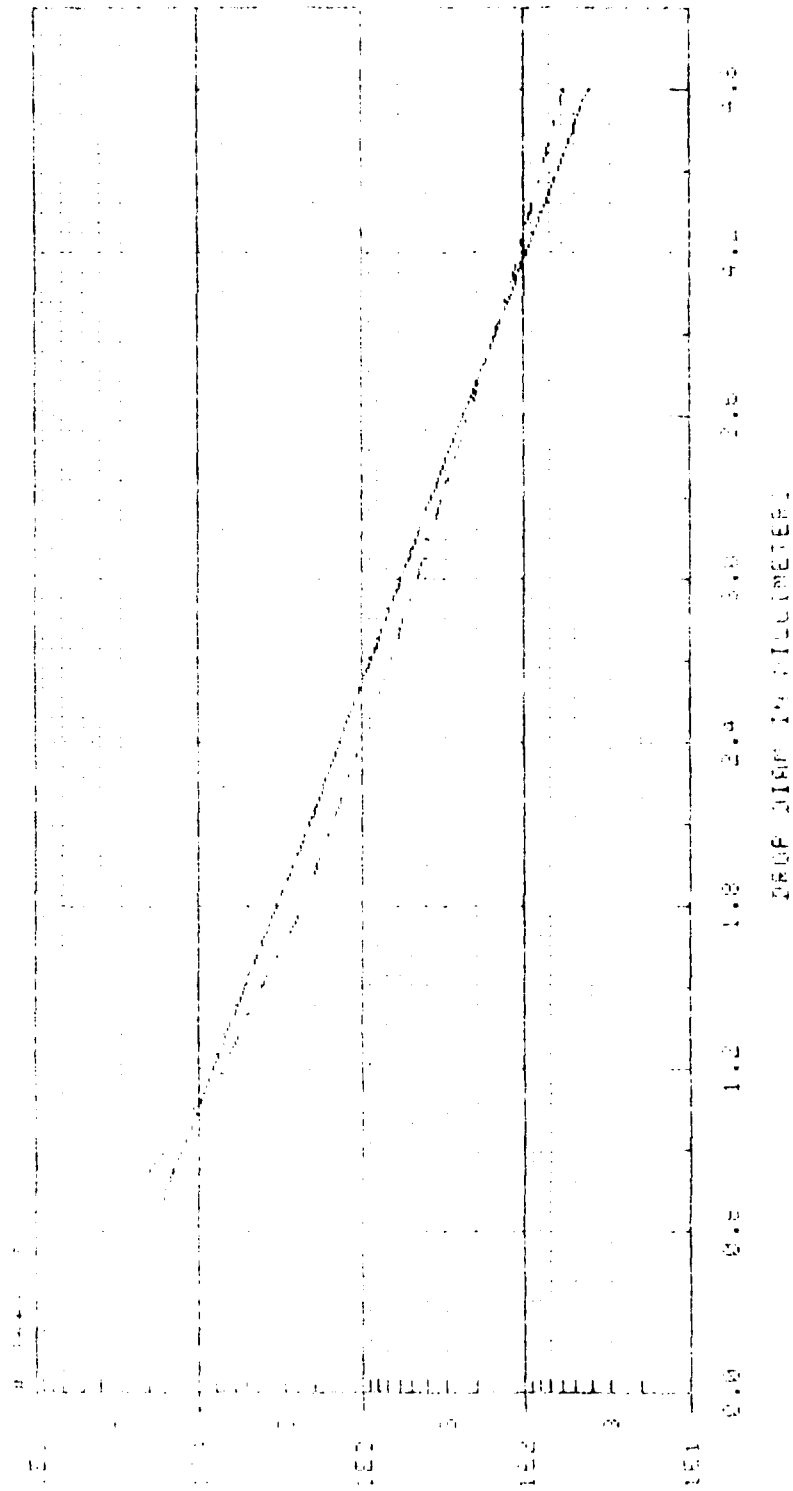

FIGURE 12

# DROP DENSITY VS DROP SIZE

CHURCH & DWIGHT CO. 1950-51

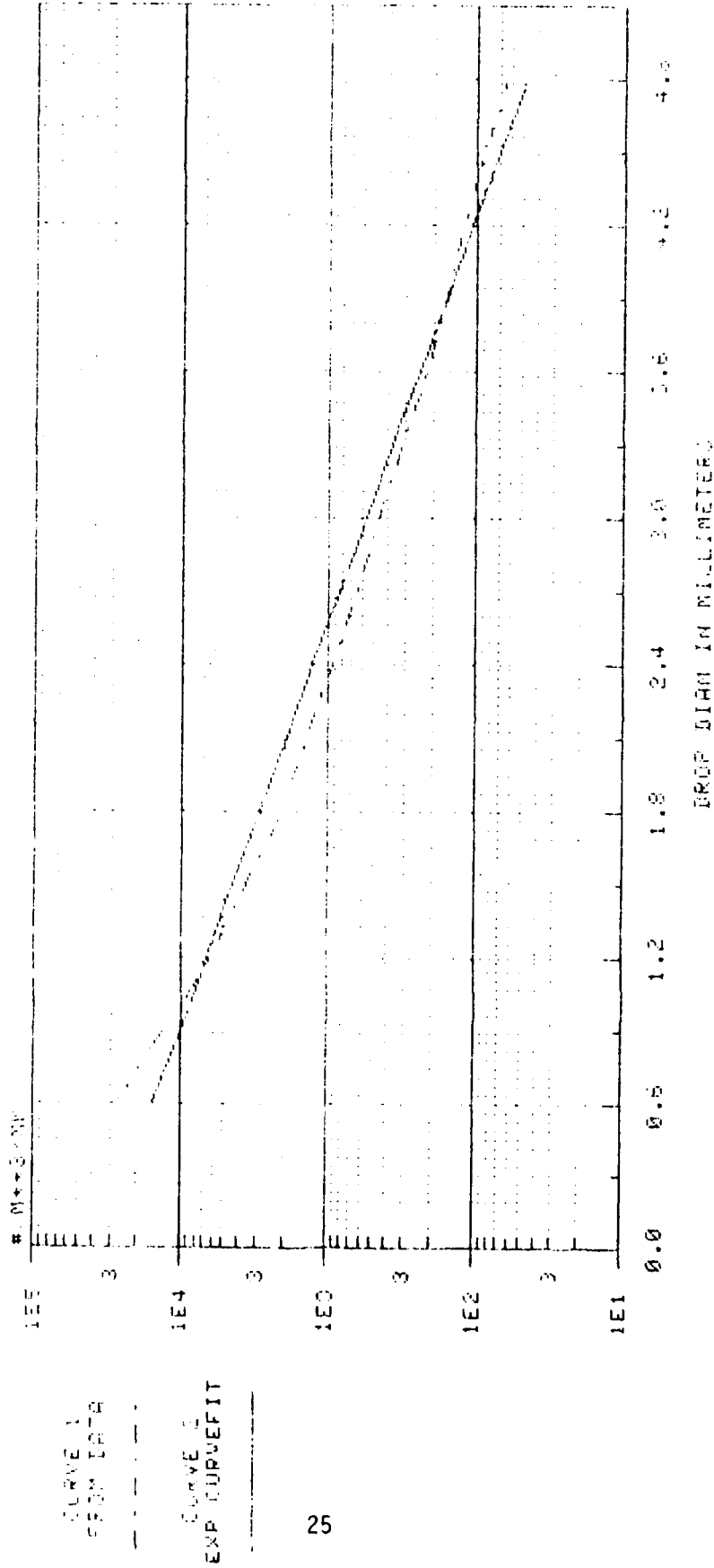



FIGURE 13

# DROP DENSITY VS DROP SIZE

SAMPLE LOCATION 37-49 (ROW 5)

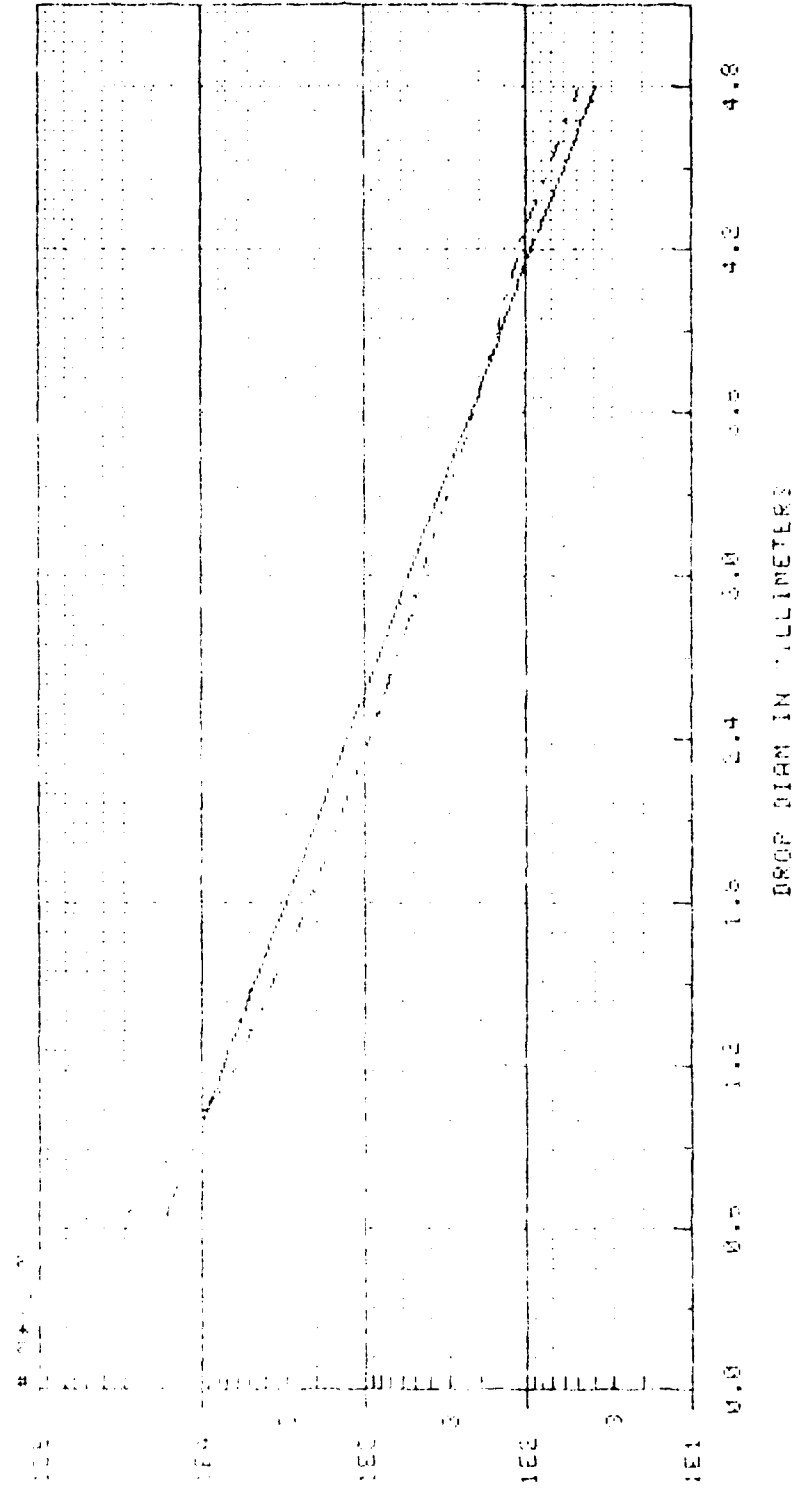

FIGURE 14

# DROP DENSITY VS DROP SIZE

SAMPLE LOCATIONS 45-54 (FROM 61)

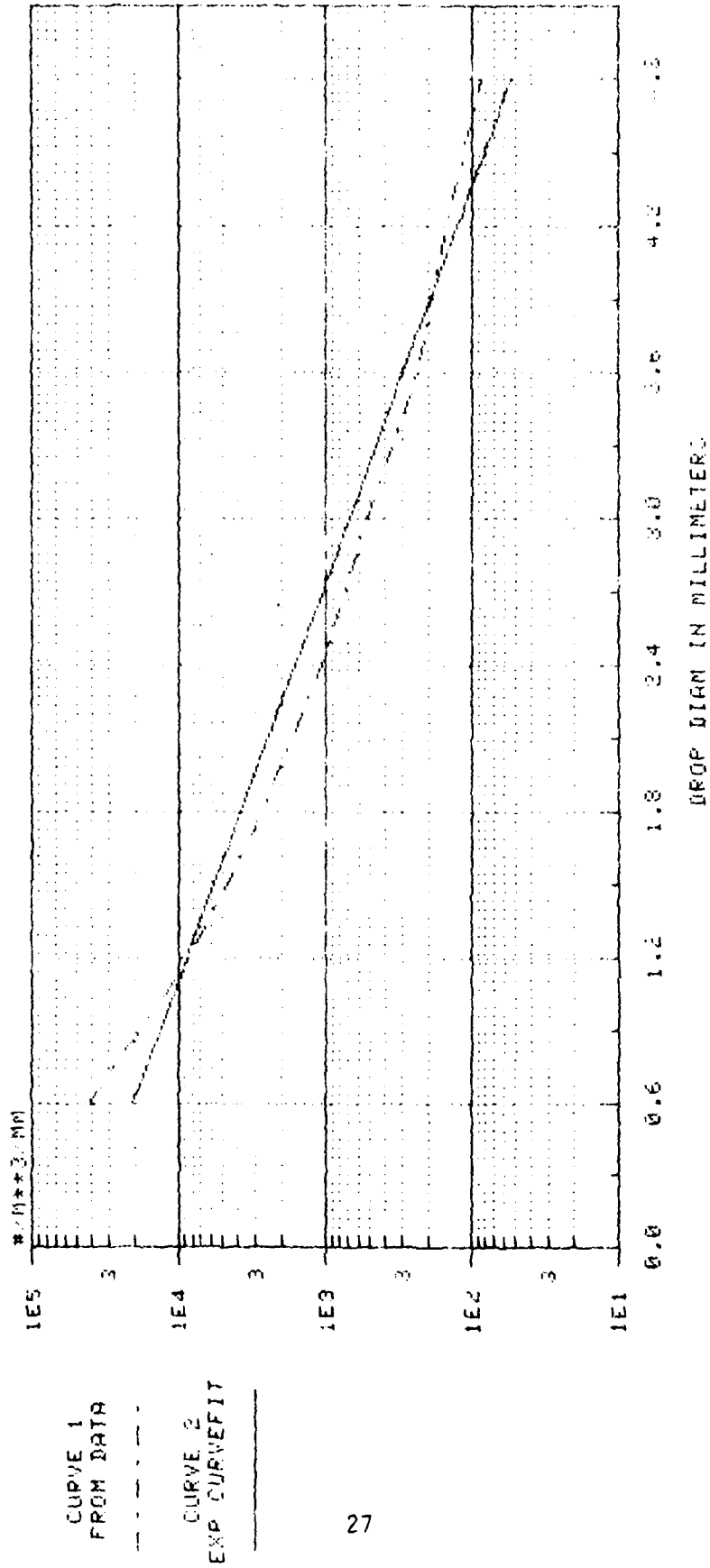

FIGURE 15

# DROP DENSITY VS DROP SIZE

SAMPLE LOCATIONS SERIES (FROM 7)

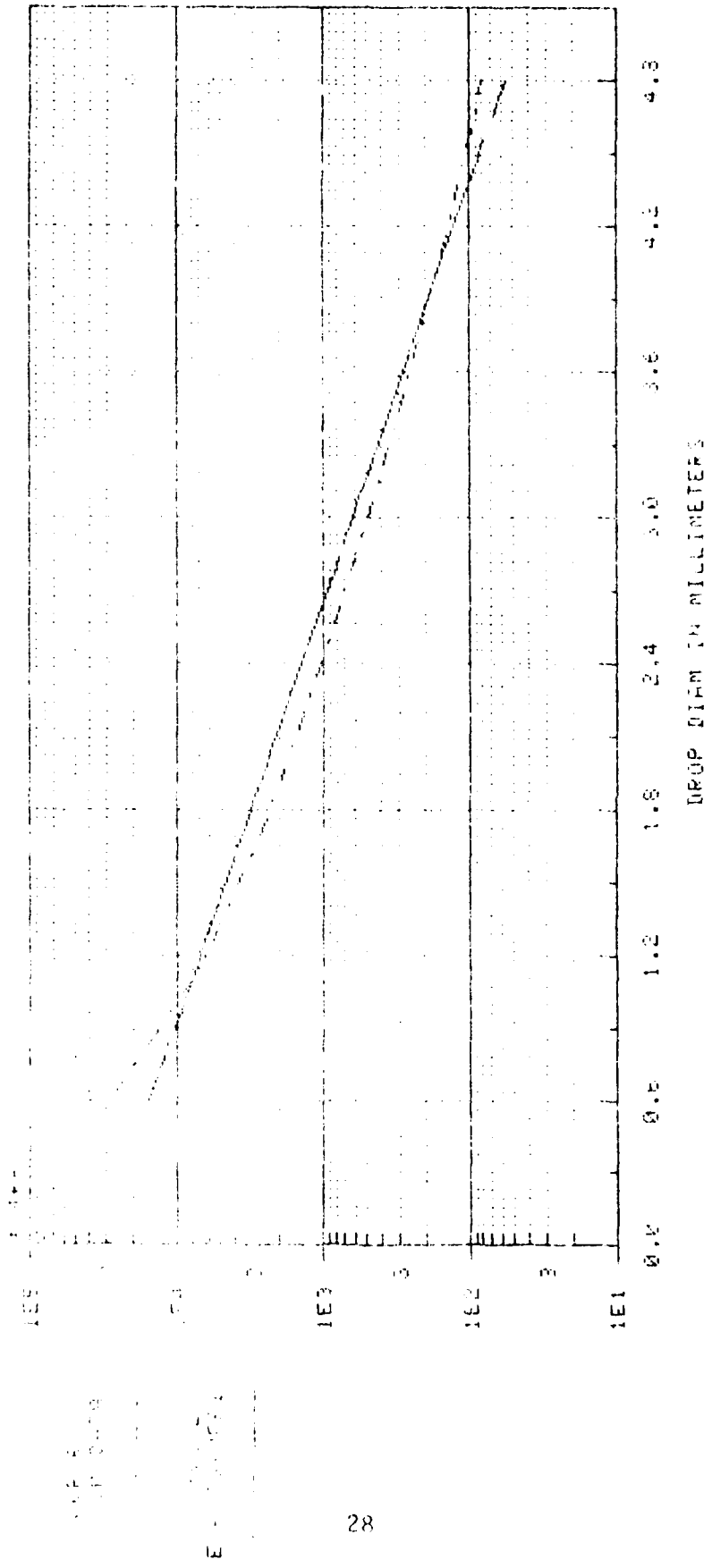

FIGURE 16

# DROP DENSITY VS DROP SIZE

SAMPLE LOCATIONS 54-72 (ROW 3)

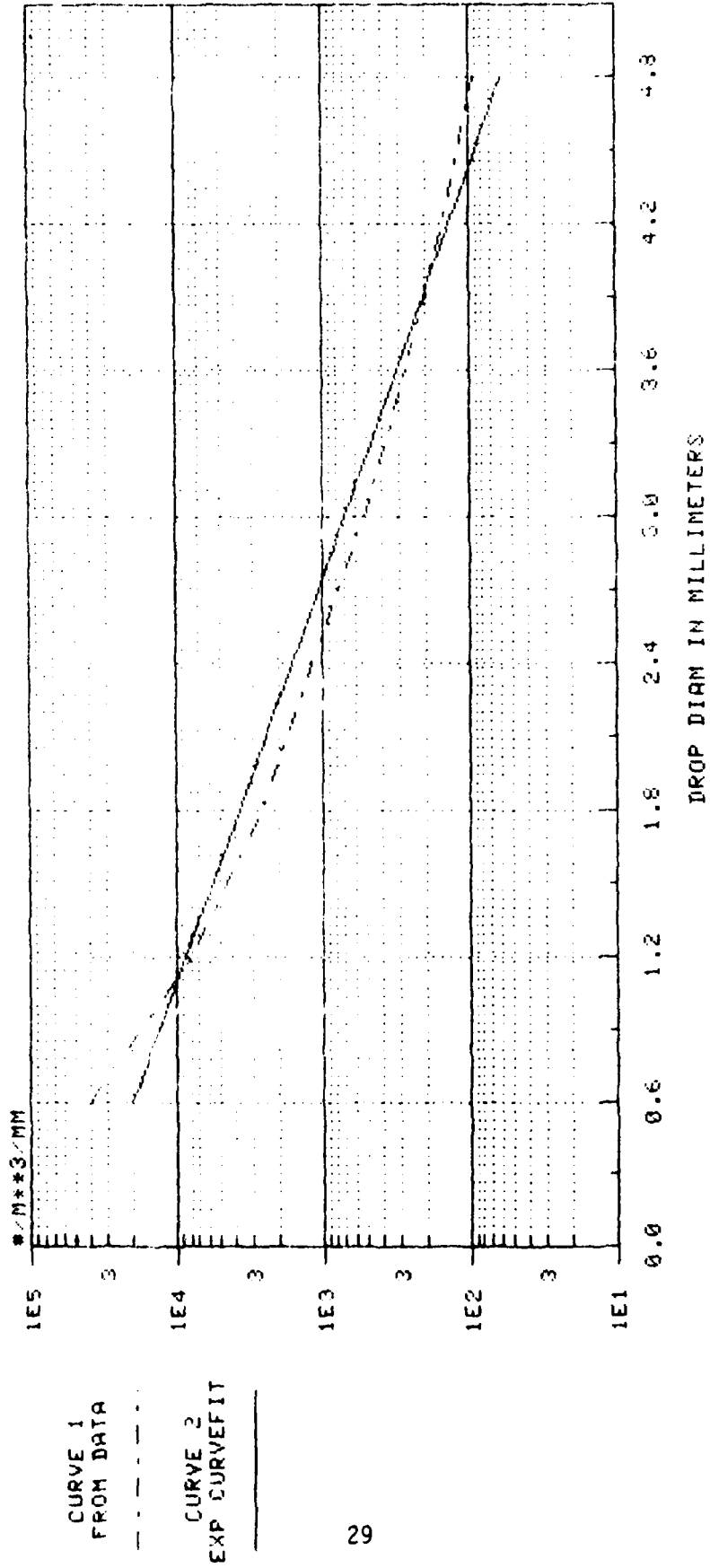

FIGURE 17

# DROP DENSITY VS DROP SIZE

CHARLES COUNTY, IOWA (1951-52)

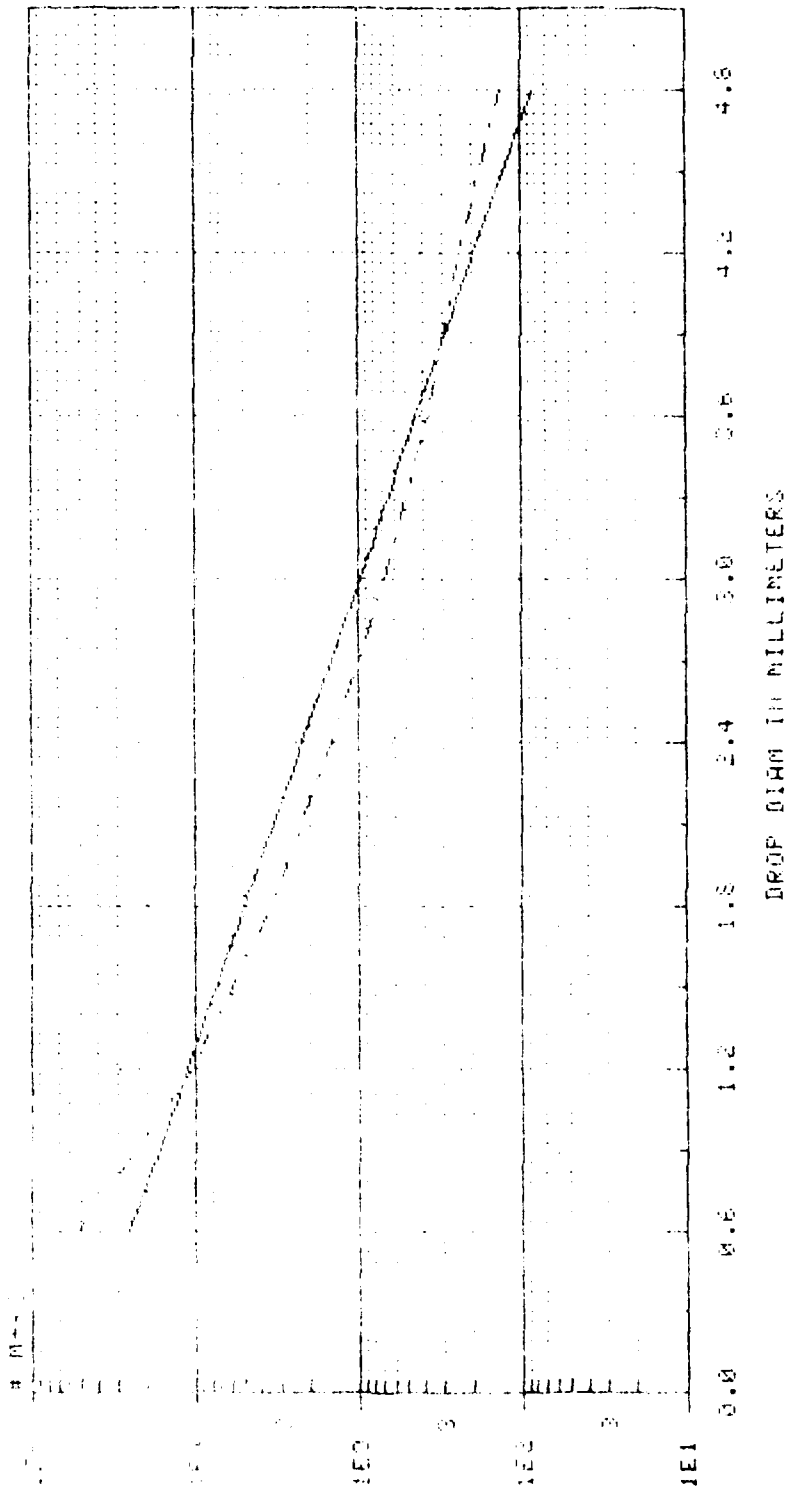





FIGURE 20

# AVERAGE DROP DENSITY VS SAMPLE LOCATION

FOR EACH DROP SIZE INTERVAL

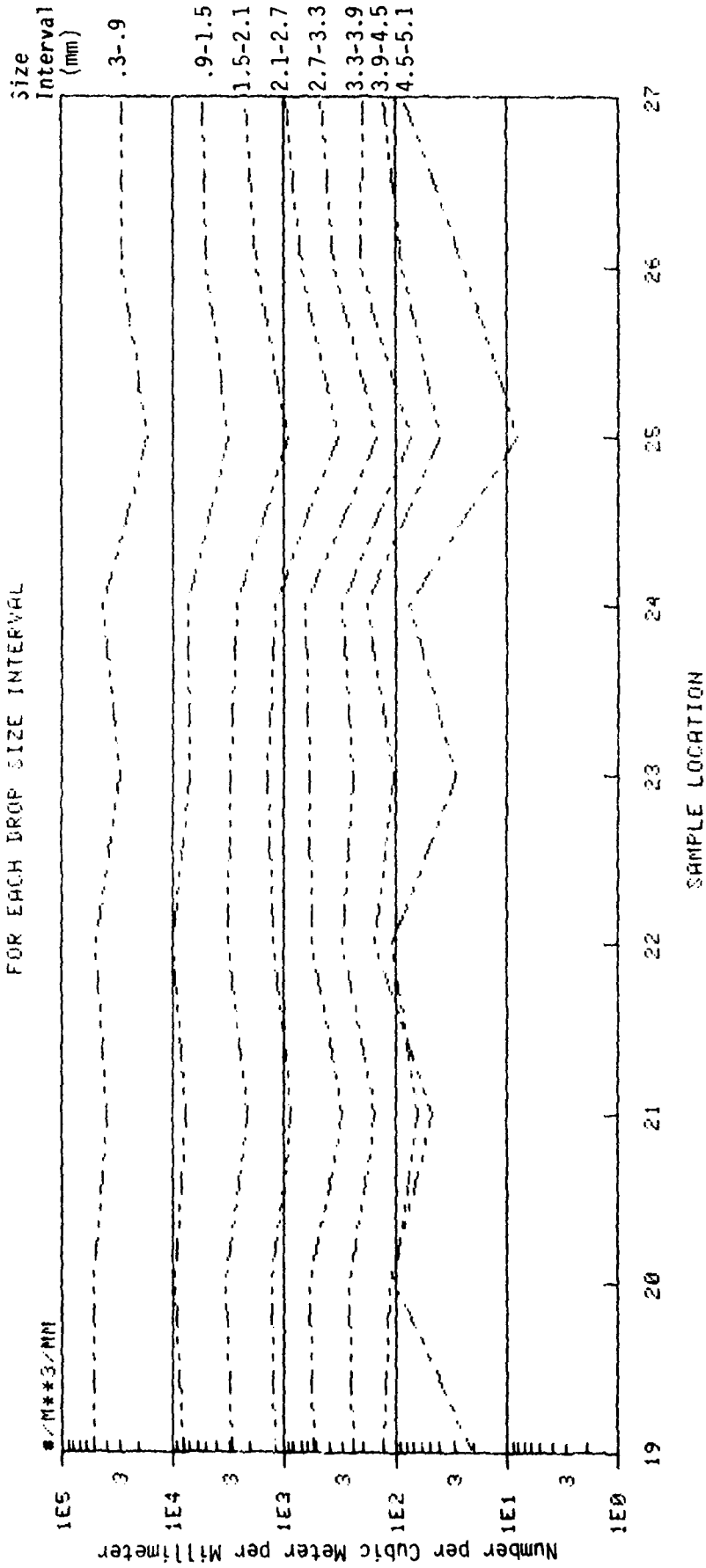



FIGURE 21

# AVERAGE DROP DENSITY VS SAMPLE LOCATION

FOR EACH DROP SIZE INTERVAL

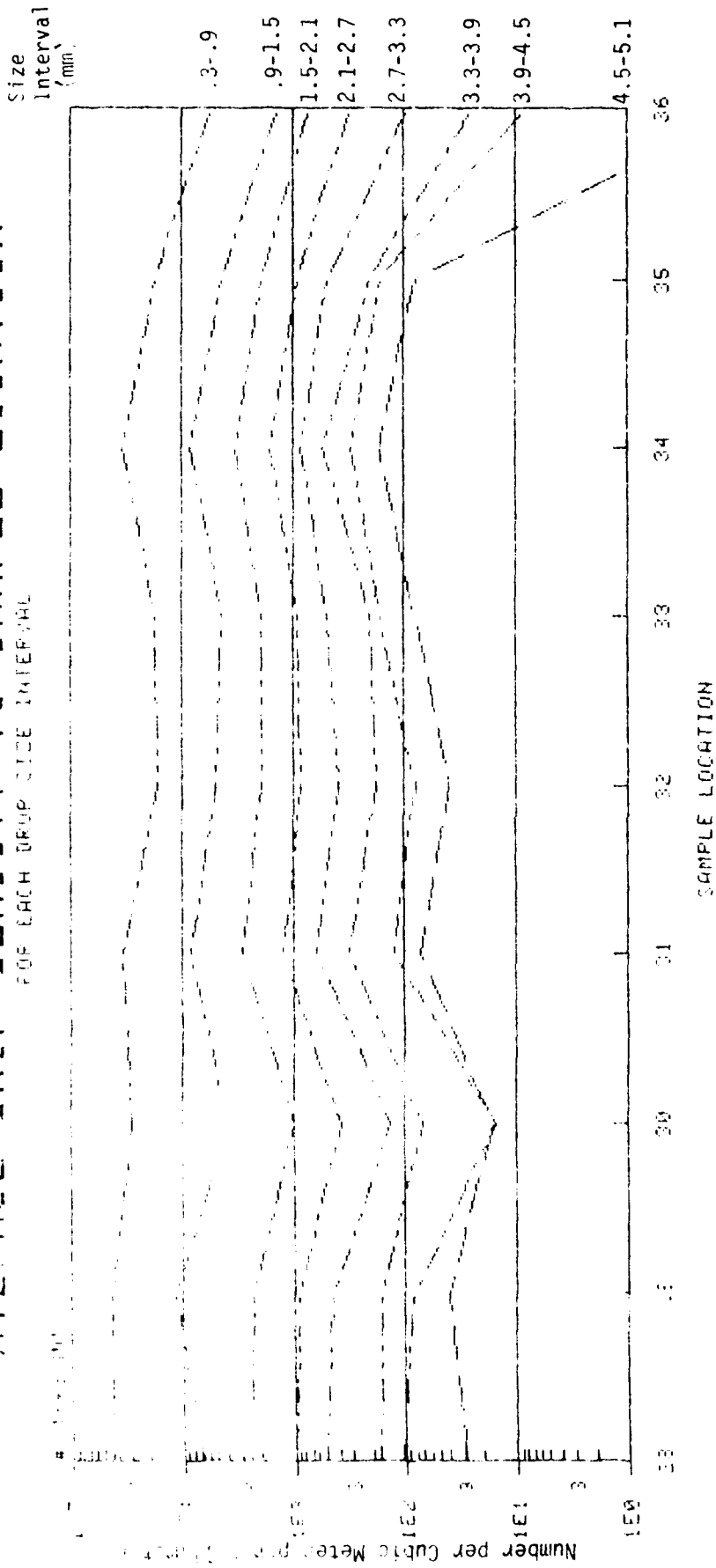

FIGURE 22

# AVERAGE DROP DENSITY VS SAMPLE LOCATION

FOP EACH DROP SIZE INTERVAL

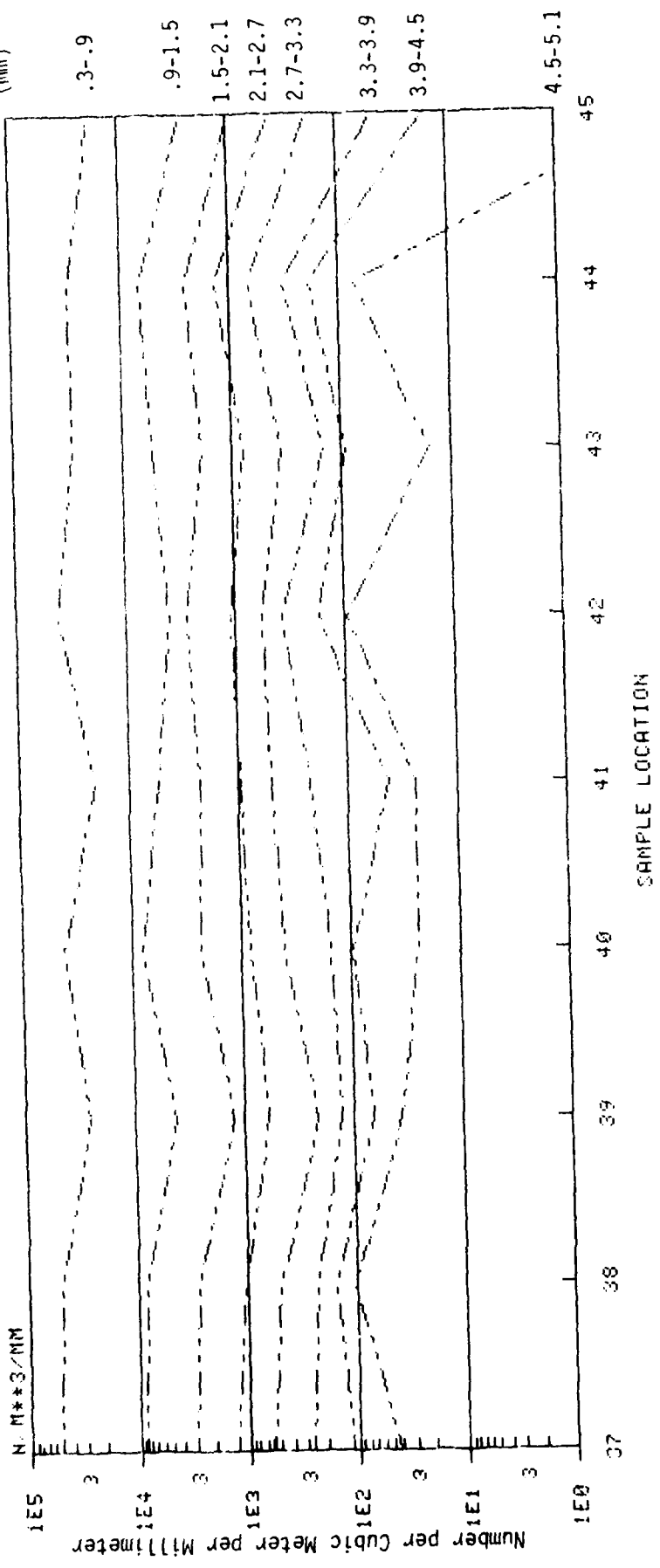



FIGURE 24

# AVERAGE DROP DENSITY VS SAMPLE LOCATION

FOR EACH DROP SIZE INTERVAL

Size Interval (mm)  
 .3-.9  
 .9-1.5  
 1.5-2.1  
 2.1-2.7  
 2.7-3.3  
 3.3-3.9  
 3.9-4.5  
 4.5-5.1

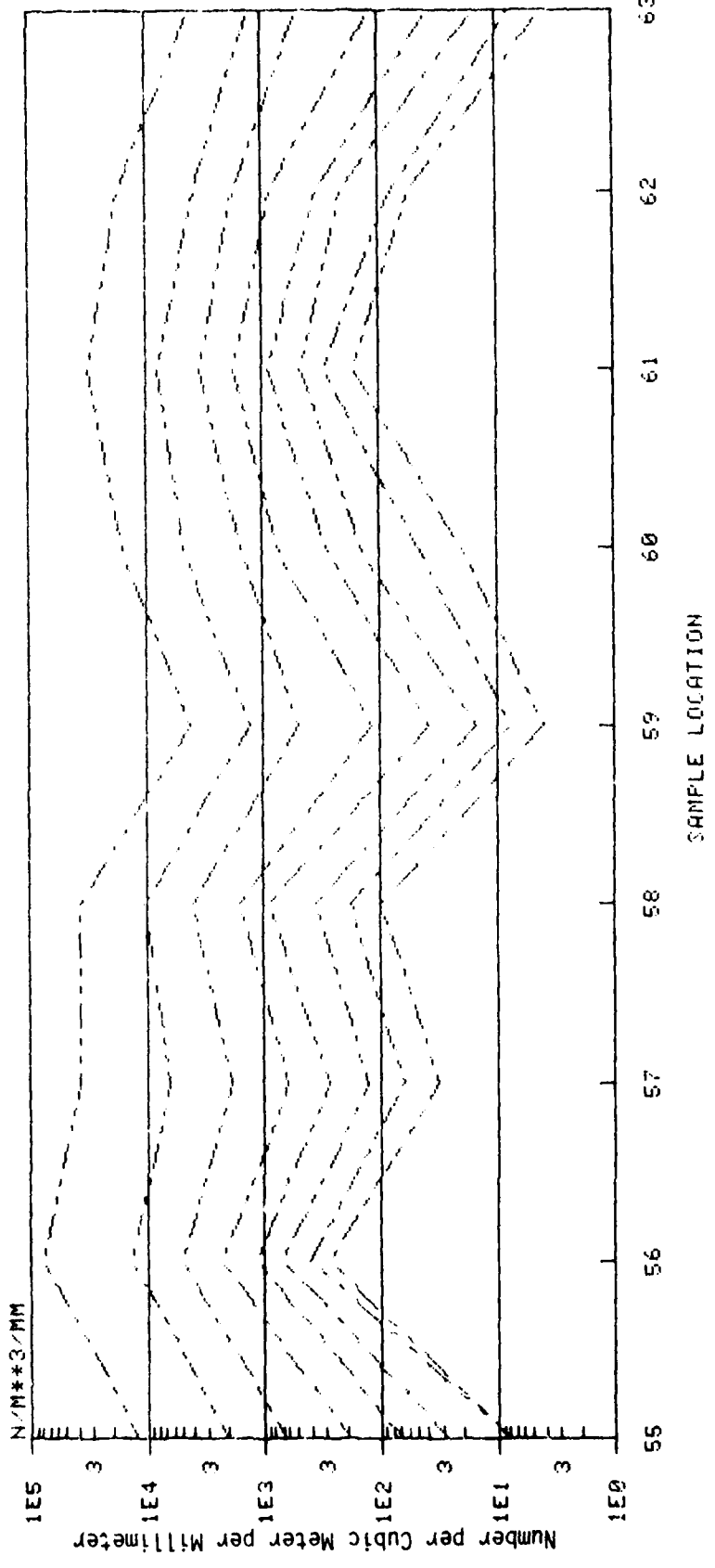



FIGURE 26

# AVERAGE DROP DENSITY VS SAMPLE LOCATION

FOR EACH DROP SIZE INTERVAL

Size Interval (mm)  
 .3-.9  
 .9-1.5  
 1.5-2.1  
 2.1-2.7  
 2.7-3.3  
 3.3-3.9  
 3.9-4.5  
 4.5-5.1

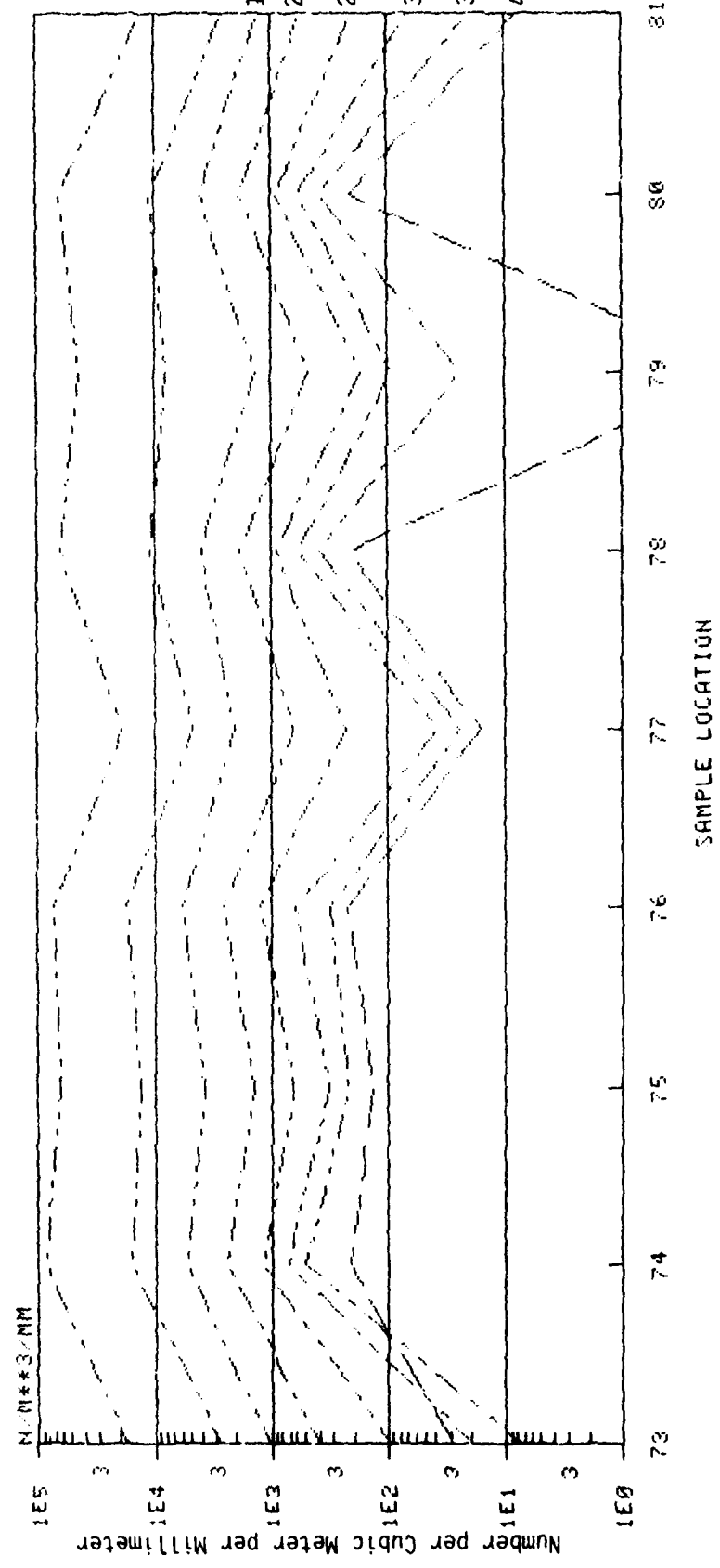
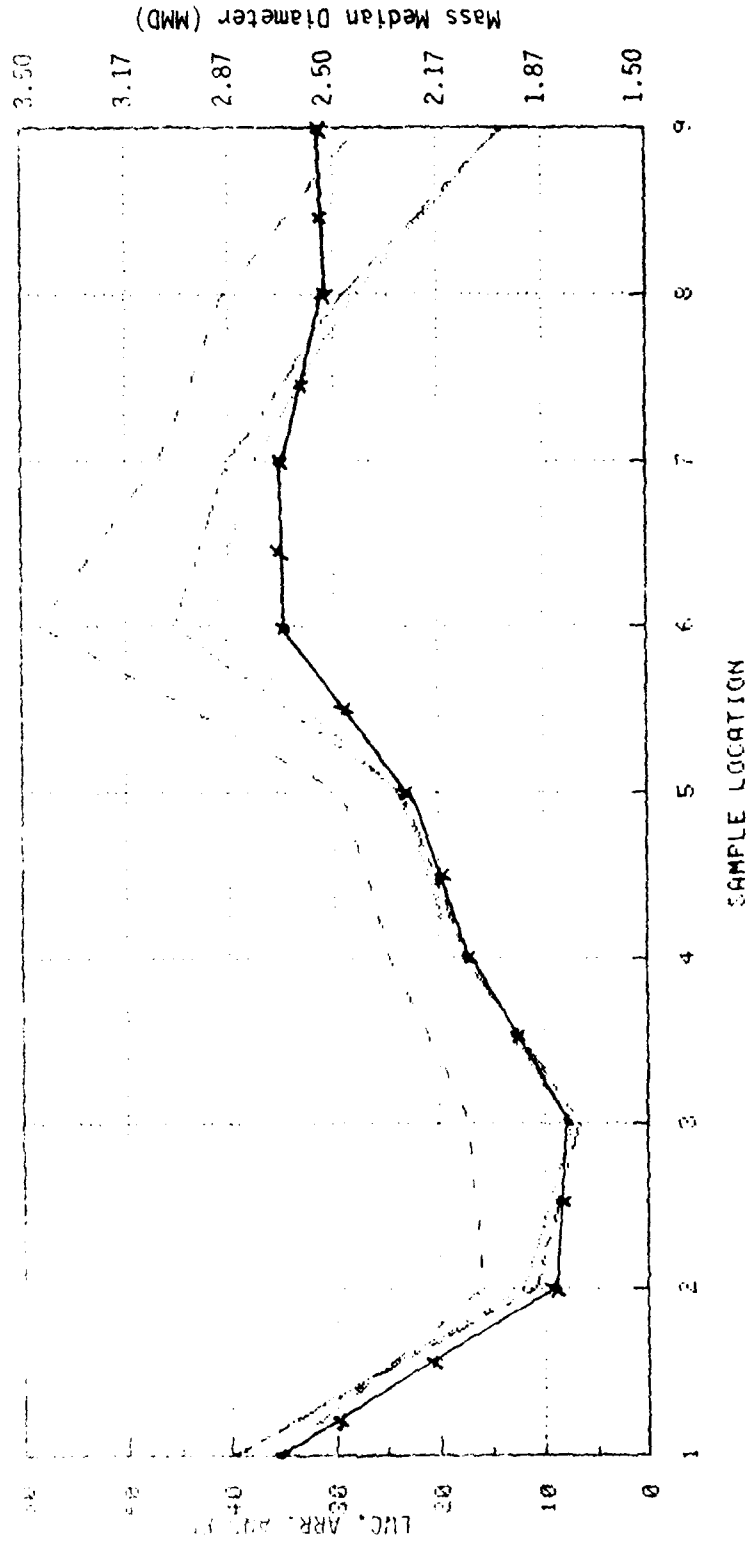

FIGURE 27  
 LQD WATER CNTHT, MMD, AND RAIN RTE  
 VS SAMPLE LOCATION



Liquid Water Content Units: g/M \* X 3

Rain Rate Units: in/hr

Mass Median Diameter Units: millimeters

CURVE 1  
 LQD WATER

CURVE 2  
 MMD

CURVE 3  
 RAIN RATE

CURVE 4  
 ACCUM RAIN

FIGURE 28

LQD WATER CNTNT, MMD, AND RAIN RTE  
VS SAMPLE LOCATION

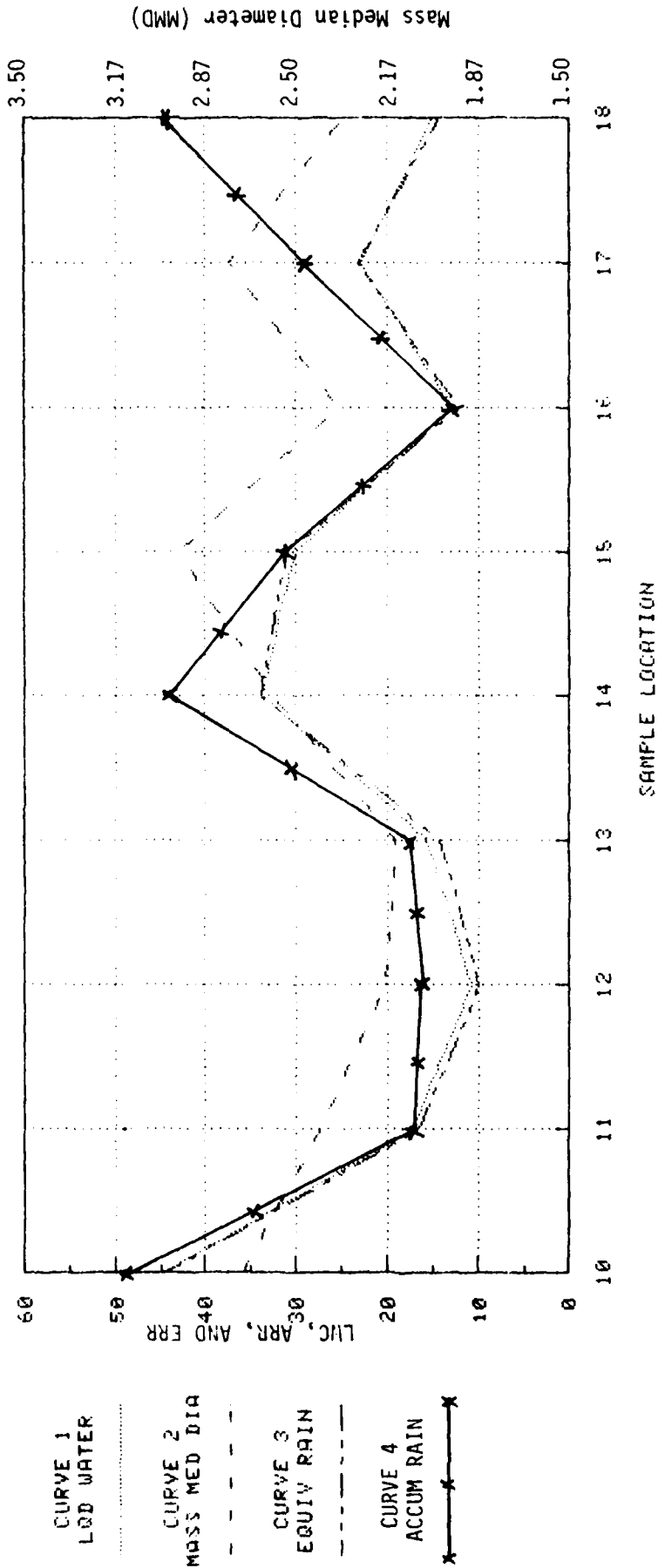

Liquid Water Content Units: g/M \* \* 3

Rain Rate Units: in/hr

Mass Median Diameter Units: millimeters



LIQUID WATER CONTENT, MMD, AND RAIN RATE

FIGURE 29

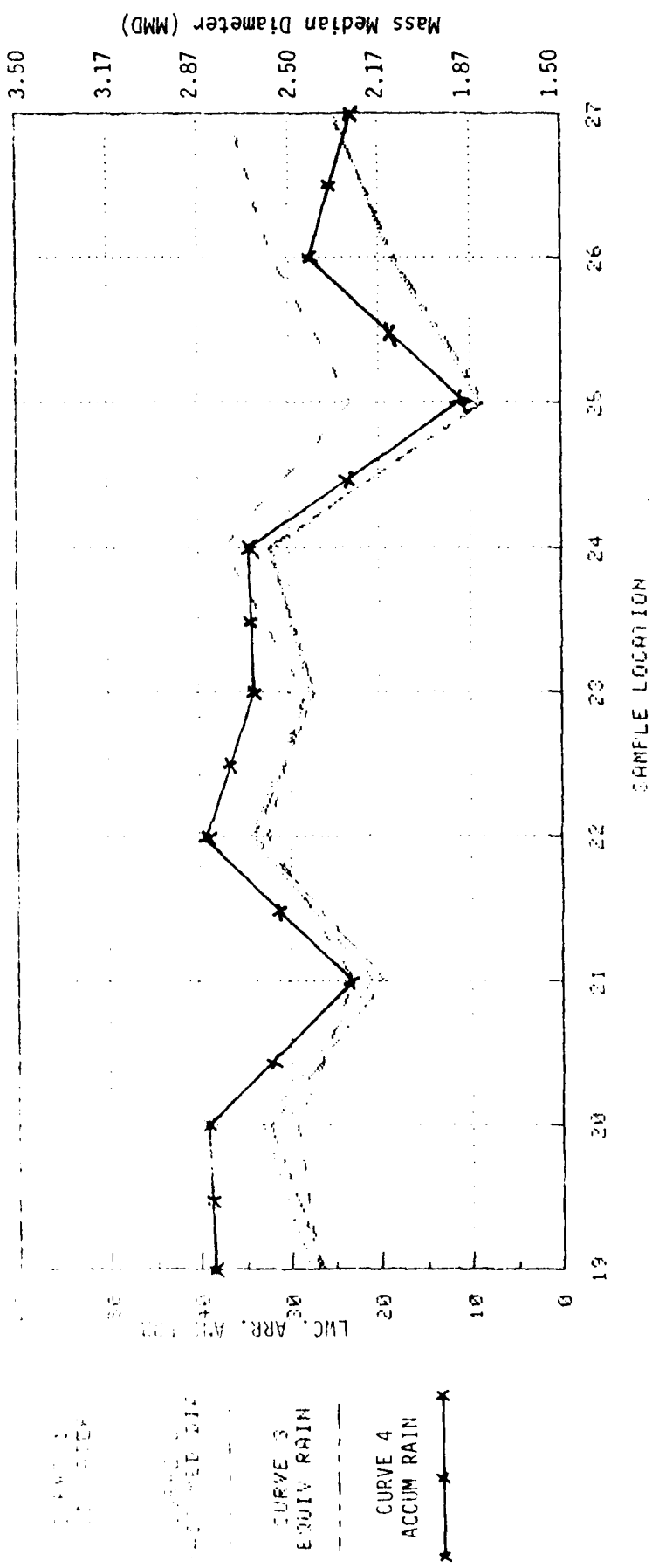

Liquid Water Content Units: g/M \* \* 3

Rain Rate Units: in/hr

Mass Median Diameter Units: millimeters

FIGURE 30

LQD WATER CNTNT, MMD, FND RAIN RTE  
VS SAMPLE LOCATION

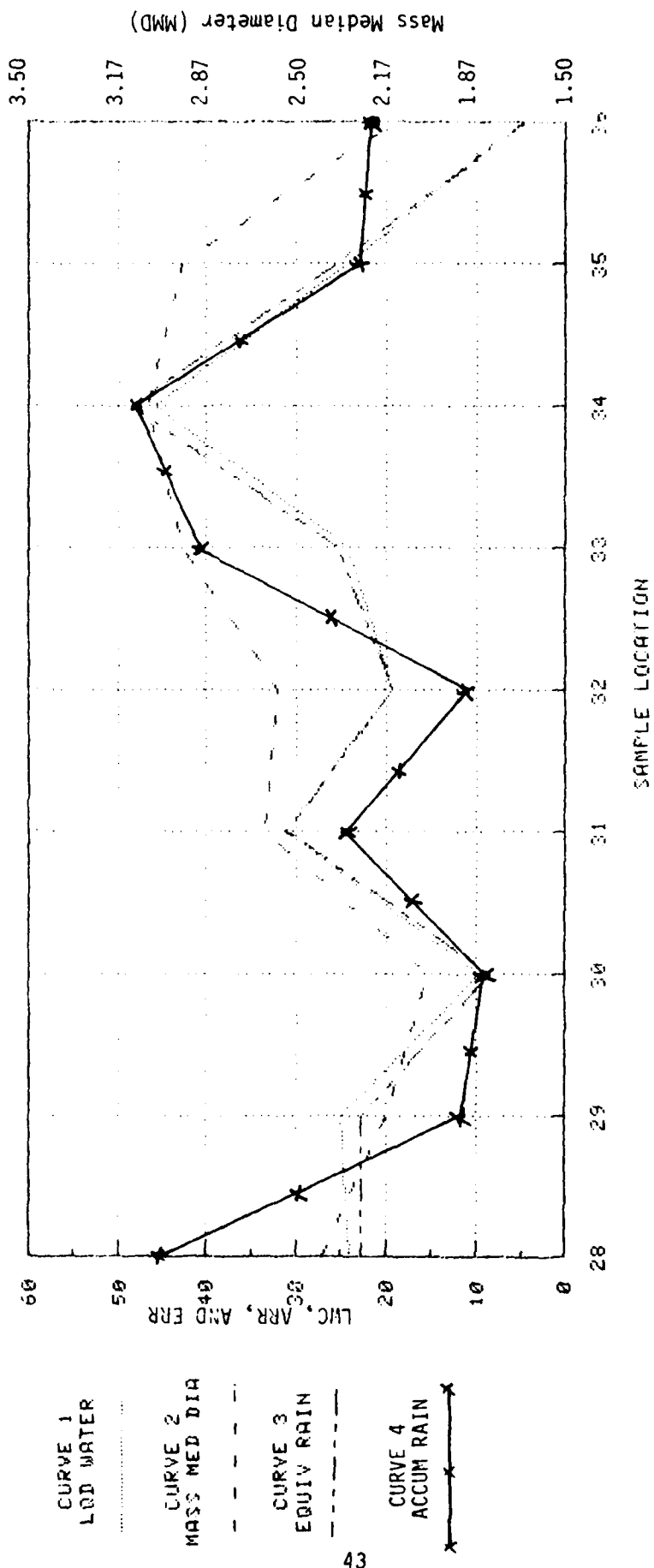

Liquid Water Content Units: g/M \* 3

Rain Rate Units: in/hr

Mass Median Diameter Units: millimeters

FIGURE 31

LIQ WATER CNTNT, MMD, AND RAIN RTE  
VS SAMPLE LOCATION

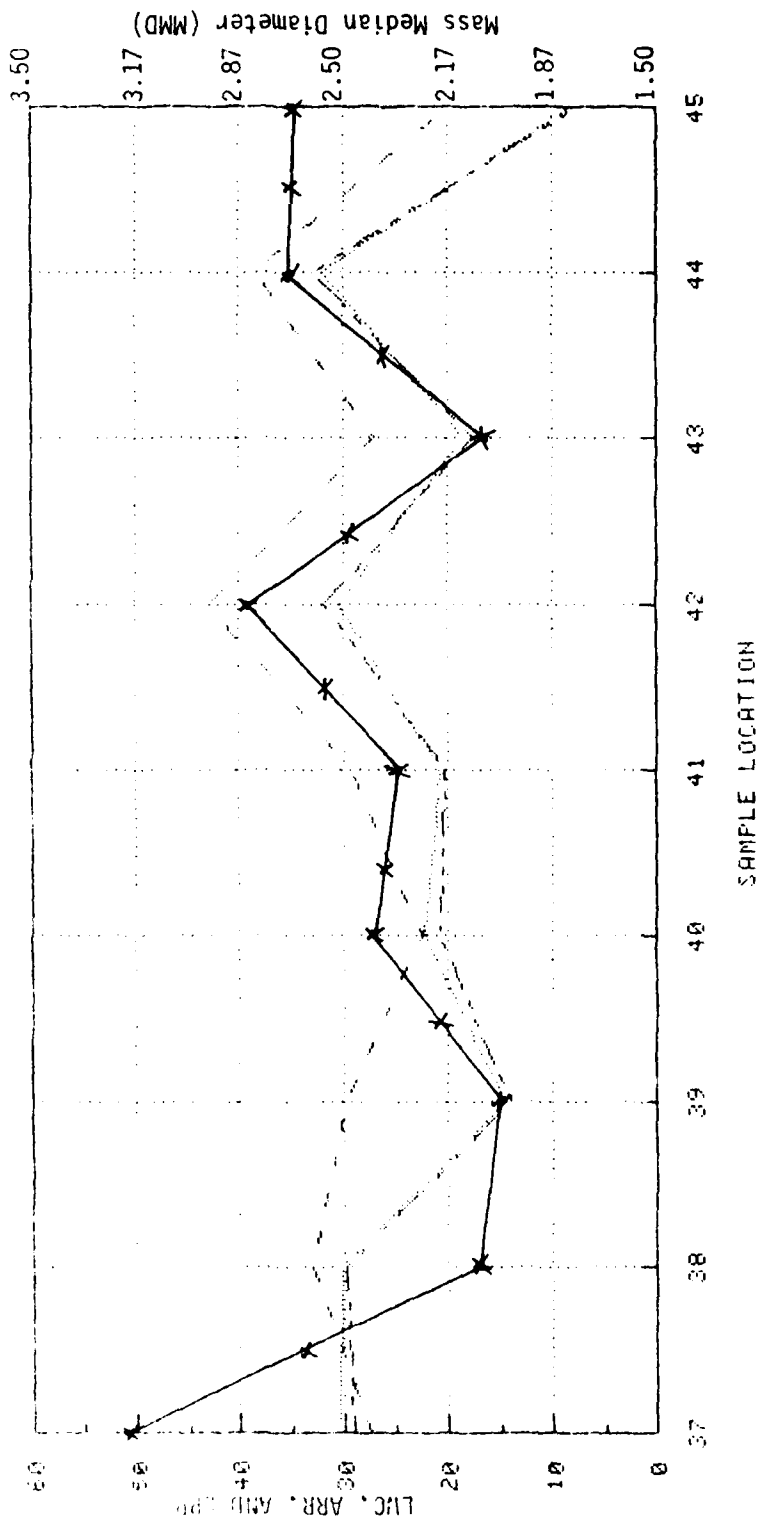

Liquid Water Content Units: g/M \* \* 3

Rain Rate Units: in/hr

Mass Median Diameter Units: millimeters

CURVE 1  
LWC

CURVE 2  
ARR

CURVE 3  
EQUIV RAIN

CURVE 4  
ACCUM RAIN

FIGURE 32

LQD WATER CNTNT, MMD, AND RAIN RTE  
VS SAMPLE LOCATION

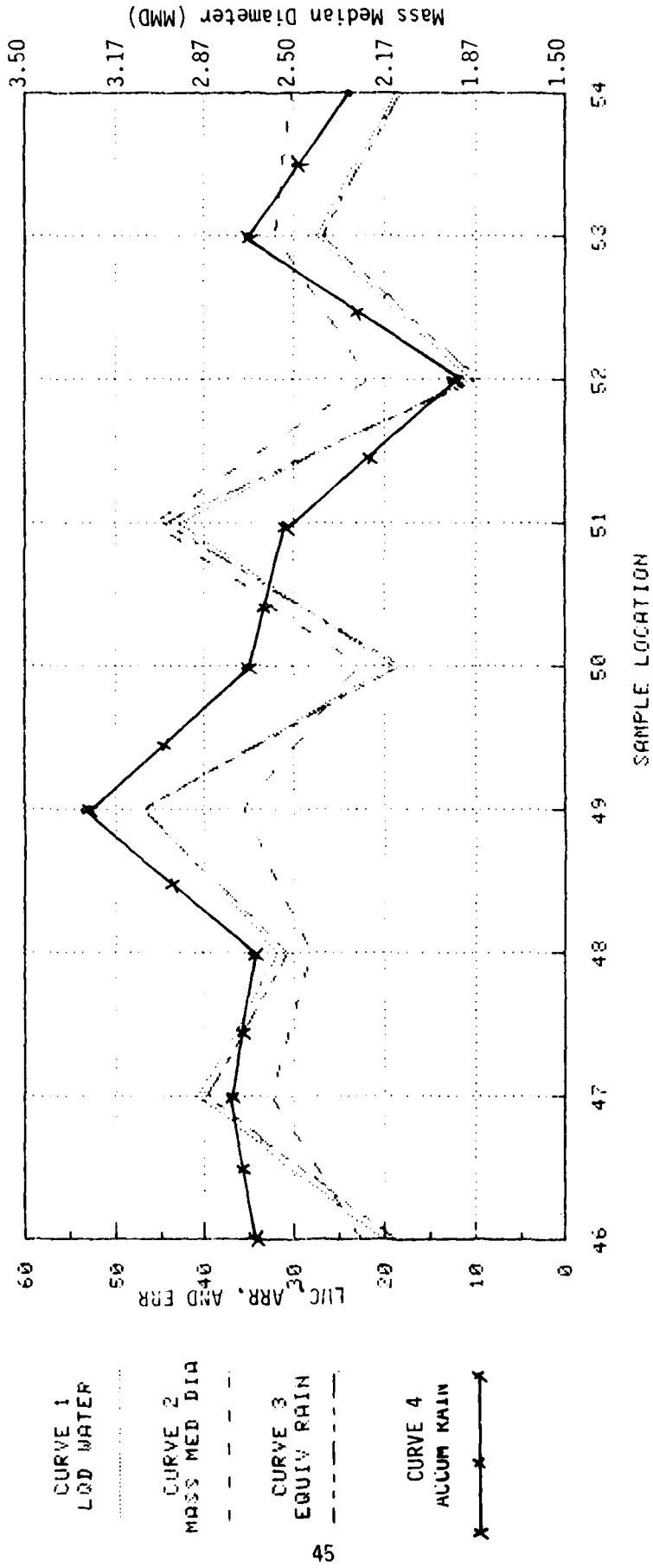

Liquid Water Content Units: g/M \* \* 3

Rain Rate Units: in/hr

Mass Median Diameter Units: millimeters

FIGURE 33

**RAIN RTE**

**LQD WATER CNTNT, MMD, AND**  
VS SAMPLE LOCATION

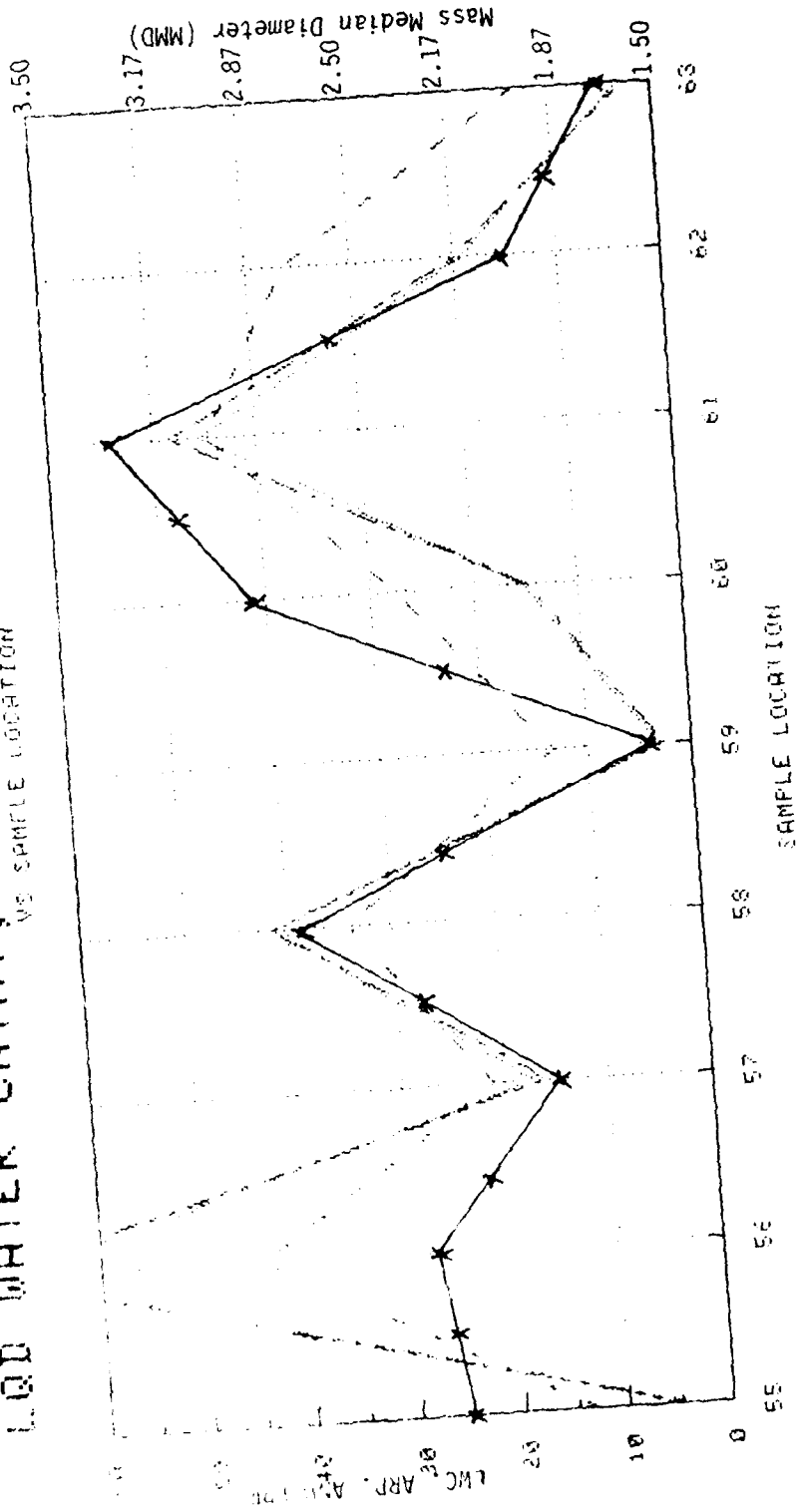

Liquid Water Content Units: g/M \* \* 3

Rain Rate Units: in/hr

Mass Median Diameter Units: millimeters

CURVE 1  
 LWC  
 CURVE 2  
 MMD  
 CURVE 3  
 EQUIV RAIN  
 CURVE 4  
 ACCUM RAIN

FIGURE 34

LQD WATER CNTNT, MMD, AND RAIN RTE  
VS SAMPLE LOCATION

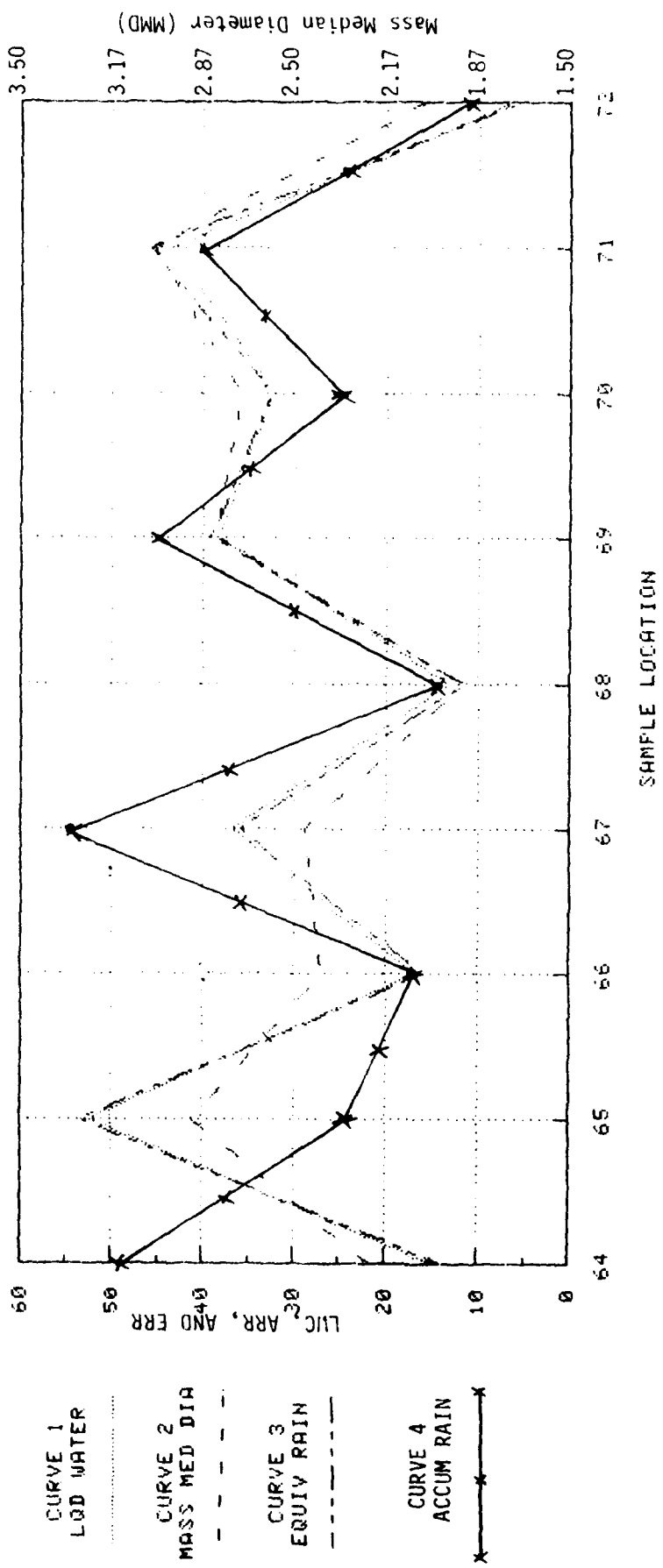

Liquid Water Contents Units: g/M \* \* 3

Rain Rate Units: in/hr

Mass Median Diameter Units: millimeters

FIGURE 35

LQD WATER CNTHT, MMD, AND RAIN RTE  
VS SAMPLE LOCATION

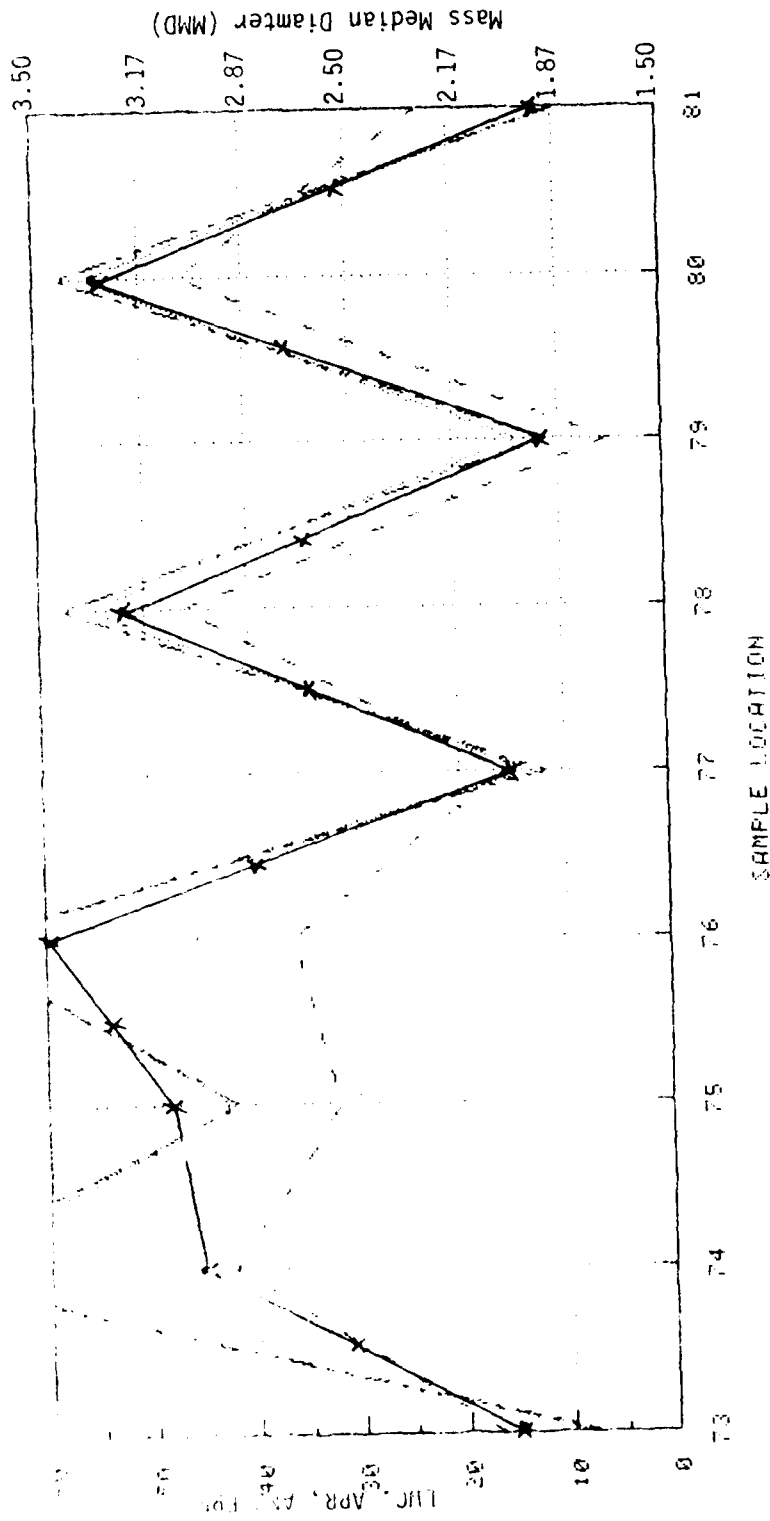

Liquid Water Content Units: g/M \* \* 3

Rain Rate Units: in/hr

Mass Median Diameter Units: millimeters

- CURVE 1  
LWC
- CURVE 2  
MMD
- CURVE 3  
RAIN RATE
- CURVE 4  
ACCUM RAIN

## Appendix A

### NUANCES OF THE IITRI COUNTER

1. A warmup period of 20-30 minutes is required before the counts on the calibration slide settle down and become repeatable.
2. There are holes in the IITRI bellows to allow the water to drain out. Make sure these are on the bottom. Otherwise, water will pool in the bellows and drops will splash water on the lens, causing erroneous drop counts. This condition will appear on the videocon as a drop that doesn't move. Your eye can easily pick it out.
3. Drop splash can cause erroneous readings. It can be eliminated, however. All areas around the hood opening and on top of the Counter should be covered with green fiber packing material commonly known as "horsehair." Splash guards are especially critical on the interior of the hoods. However, it was found that the horsehair was too thick and would protrude into the field of view. "Scotchbrite" scouring pads were substituted and they seemed to work as well.
4. When counts in channel 2 got above about 25,000 per 300 seconds (833 per 10 seconds) the Counter saturated. The consequence of saturation is that two or more drops are counted as one larger drop, causing too high mass median diameter and liquid water content estimates. The solution to the problem is to decrease the hood opening. It is recommended that when drop counts in channel 2 get above 17,000 per 300 seconds the hood opening be decreased. Conversely, a lot of rainfield parameter variability from one sample to another was experienced when counts were below 7000 in channel 2. An adequate sample size to ensure repeatability is about 12000-14000 counts in channel 2. One can obtain this either by changing the sample time or sample volume.
5. The IITRI Counter depends on careful alignment of the optics for correct operation. Improper alignment will cause sizing and number counts from a calibration slide to change as the slide is moved about in the sample volume. Be sure to check this occasionally.



Appendix B

DELUGE ANALYSIS PROGRAM LISTING

```

$control uslinit,FILE=8
C THIS PROGRAM TAKES IITRI COUNTER DATA AND COMPUTES RAINFIELD
C PARAMETERS. THESE INCLUDE LIQUID WATER CONTENT, MASS MEDIAN
C DIAMETER, AND EQUIVALENT NATURAL RAIN RATE.
C
C THIS VERSION OF THE PROGRAM TAKES DATA ENTERED INTO A
C COMPUTER FILE AND COMBINES IT INTO ROW FORM FOR COMPUTA-
C TION OF ROW AVERAGES.
C IT ALSO USES A CURVEFIT ALGORITHM AND EXPLICIT INTEGRATION
C TO COMPUTE THE MASS (LIQUID WATER CONTENT) WITHIN EACH
C INTERVAL.
C
PROGRAM DELUGES
real m(90,8), n(90,8), dupl2(8), dlowl2(8), dupl5(8), dlowl5(8)
1, dupl8(8), dlowl8(8), diaml2(8), diaml5(8), diaml8(8), er(8)
real mmd, norm(8), AMASS(90), TOTALM(8), TOTALN(8)
real corl(8), a(8,7), percent(8), accum(9), M1, M2
data corl/.99456,.98376,.97302,.96185,.95144,.93999,
1.92912,.91841/
data a/0.,0.,0.,0.,0.,0.,0.,0.,0.01102,0.,0.,0.,0.,0.,0.00934,
1.01265,0.,0.,0.,0.,0.,0.00885,.01050,.01379,0.,0.,0.,0.,
2.00814,.00954,.01118,.01469,0.,0.,0.,0.00790,.00906,.01022,
3.01185,.01604,0.,0.,0.,0.00812,.00858,.00951,.01090,.01228,
4.01645,0.,0.00765,.00834,.00900,.00995,.01133,.01317,.01731/
data dupl2/.22,.42,.62,.82,1.02,1.22,1.42,1.62/
data dlowl2/.02,.22,.42,.62,.82,1.02,1.22,1.42/
data diaml2/.12,.32,.52,.72,.92,1.12,1.32,1.52/
data dupl5/.90,1.5,2.1,2.7,3.3,3.9,4.5,5.1/
data dlowl5/.3,.9,1.5,2.1,2.7,3.3,3.9,4.5/
data diaml5/.6,1.2,1.8,2.4,3.0,3.6,4.2,4.8/
data dupl8/1.5,2.5,3.5,4.5,5.5,6.5,7.5,8.5/
data dlowl8/.5,1.5,2.5,3.5,4.5,5.5,6.5,7.5/
data diaml8/1.0,2.0,3.0,4.0,5.0,6.0,7.0,8.0/
C
C m is the mass array, n the number count array, dlowl2 is the
C array containing the lower drop size limit of each particle
C size bin when the fl.2 f setting has been selected, dupl2
C is the upper size limit of the droplet size bin.
C diaml2 is the array containing the mid point of
C each particle size bin (in millimeters) when the fl.2 f
C setting has been selected, and so forth through diaml8.
C er is the equivalent rainfall rate array, and mmd is the
C mass median diameter.
C amass contains the total liquid water content of each sample.
C totalm and totaln hold the average liquid water content
C and number counts for each row.
C iloc is the sample number, press the nozzle (not manifold) press-
C ure, fset is the f setting on the iitri counter, hood is the hood
C opening in inches, and time is the sample time in seconds.
C

```

```

500 READ(8,550,END=700) ILOC,PRESS,FSET,HOOD,TIME
550 FORMAT(I3,3F3.1,F4.0)
C I IS THE DATA BIN COUNTER. THE PROGRAM IS WRITTEN SO THAT
C THE SMALLEST BIN IS ASSUMED TO BE INPUT FIRST
READ(8,551) (N(ILOC,I),I=1,8)
551 FORMAT(F5.0,2F4.0,5F3.0)
GO TO 500
700 CONTINUE
DO 200 ILOC=1,81
convert =1/61024.
c convert is the conversion factor from cubic inches to cubic
c meters.
c
C BINWIDTH = SIZE OF BIN INTERVAL IN MILLIMETERS
c now test for f setting and compute volume sampled based on it.
if(fset-1.5)30,40,50
30 volume=.781*.687*hood*convert*7.5*time
BINWIDTH=.2
go to 60
40 volume=2.156*1.875*hood*convert*7.5*time
BINWIDTH=.6
go to 60
50 volume = 0.281*2.875*hood*convert*7.5*time
BINWIDTH=1.0
60 CONTINUE
c
c the following is an edge correction algorithm.
C (TAKEN FROM THE EHNI REPORT)
i=8
2 N(ILOC,I) = N(ILOC,I)/cor1(i)
if(i.eq.1) go to 3
do 1 j=1,(i-1)
1 N(ILOC,J) = N(ILOC,J) -N(ILOC,I)*a(i,j)
i=i-1
go to 2
3 MASS(ILOC)=0.
c convert to mass measurements
if(fset-1.5) 70,80,90
70 do 71 i=1,8
C IF AND JJ ARE USED TO ALLOW THE CALCULATION OF THE SLOPE
C OF THE DISTRIBUTION WHEN THE SIZE INTERVAL IS ON EITHER
C END OF THE DISTRIBUTION (I=1 OR I=8). WHEN THIS OCCURS
C THE PROGRAM SIMPLY USES THE NUMBER IN THAT INTERVAL RATHER
C THAN THE AMOUNT IN THE INTERVAL BELOW OR ABOVE IT FOR
C SLOPE DETERMINATION.
ii=i-1
IF(ii.EQ.0) ii=1
JJ=i+1
IF(JJ.EQ.9) JJ=8
IF(N(ILOC,I).LT..01)N(ILOC,I)=.01
IF(N(ILOC,ii).LT..01)N(ILOC,ii)=.01
IF(N(ILOC,JJ).LT..01)N(ILOC,JJ)=.01
SLOPE=((ALOG(N(ILOC,II)/(BINWIDTH*VOLUME)))-(ALOG(N(ILOC,JJ)/
(BINWIDTH*VOLUME)))/(DIAM12(II)-DIAM12(jj))

```

```

      IF (SLOPE.GT..001.AND.SLOPE.LT..001) SLOPE=.01
      M1=SLOPE*DUP12(I)
      M2=SLOPE*DLOW12(I)
C   COMPUTE THE Y INTERCEPT
      B1=ALOG((N(ILOC,I)/VOLUME*SLOPE)/(EXP(M1)
      1-EXP(M2)))
C   COMPUTE THE MASS
      M(ILOC,I)=3.1416/6*EXP(B1)*((DUP12(I)**3*EXP(M1)
      1/SLOPE-3*DUP12(I)**2*EXP(M1)/
      2(SLOPE*SLOPE)+6*DUP12(I)*EXP(M1)/SLOPE**3
      3-6*EXP(M1)/SLOPE**4)-
      4(DLOW12(I)**3*EXP(M2)/SLOPE
      5-3*DLOW12(I)**2*EXP(M2)/(SLOPE*SLOPE)
      6+6*DLOW12(I)*EXP(M2)/SLOPE**3
      7-6*EXP(M2)/SLOPE**4))*0.01
C
c   the conversion factor, (.001), converts from cubic millimeters
c   of water to grams.
      AMASS(ILOC) = AMASS(ILOC) + M(ILOC,I)
71   continue
      go to 95
80   do 81 i = 1,8
      II=I-1
      IF(II.EQ.0) II=1
      JJ=I+1
      IF(JJ.EQ.9) JJ=8
      IF(N(ILOC,I).LT..01)N(ILOC,I)=.01
      IF(N(ILOC,II).LT..01)N(ILOC,II)=.01
      IF(N(ILOC,JJ).LT..01)N(ILOC,JJ)=.01
      SLOPE=((ALOG(N(ILOC,II)/(BINWIDTH*VOLUME)))-(ALOG(N(ILOC,JJ)/
      1(VOLUME*BINWIDTH))))/(DIAM15(II)-DIAM15(jj))
      IF (SLOPE.GT..001.AND.SLOPE.LT..001) SLOPE=.01
      M1=SLOPE*DUP15(I)
      M2=SLOPE*DLOW15(I)
C   COMPUTE THE Y INTERCEPT
      B1=ALOG((N(ILOC,I)/VOLUME*SLOPE)/(EXP(M1)
      1-EXP(M2)))
C   COMPUTE THE MASS
      M(ILOC,I)=3.1416/6*EXP(B1)*((DUP15(I)**3*EXP(M1)
      1/SLOPE-3*DUP15(I)**2*EXP(M1)/
      2(SLOPE*SLOPE)+6*DUP15(I)*EXP(M1)/SLOPE**3
      3-6*EXP(M1)/SLOPE**4)-
      4(DLOW15(I)**3*EXP(M2)/SLOPE
      5-3*DLOW15(I)**2*EXP(M2)/(SLOPE*SLOPE)
      6+6*DLOW15(I)*EXP(M2)/SLOPE**3
      7-6*EXP(M2)/SLOPE**4))*0.01
      AMASS(ILOC) = AMASS(ILOC) + M(ILOC,I)
81   continue
      go to 95
90   do 91 i=1,8
      II=I-1
      IF(II.EQ.0) II=1
      JJ=I+1
      IF(JJ.EQ.9) JJ=8

```

```

IF(N(ILOC,I).LT..01)N(ILOC,I)=.01
IF(N(ILOC,II).LT..01)N(ILOC,II)=.01
IF(N(ILOC,JJ).LT..01)N(ILOC,JJ)=.01
SLOPE=((ALOG(N(ILOC,II)/(BINWIDTH*VOLUME)))-(ALOG(N(ILOC,JJ)/
1(VOLUME*BINWIDTH))))/(DIAM18(II)-DIAM18(jj))
IF (SLOPE.GT.-.001.AND.SLOPE.LT..001) SLOPE=.01
M1=SLOPE*DUP18(I)
M2=SLOPE*DLOW18(I)
C COMPUTE THE Y INTERCEPT
B1=ALOG((N(ILOC,I)/VOLUME*SLOPE)/(EXP(M1)
1-EXP(M2)))
C COMPUTE THE MASS
M(ILOC,I)=3.1416/6*EXP(B1)*((DUP18(I)**3*EXP(M1)
1/SLOPE-3*DUP18(I)**2*EXP(M1)/
2(SLOPE*SLOPE)+6*DUP18(I)*EXP(M1)/SLOPE**3
3-6*EXP(M1)/SLOPE**4)-
4(DLOW18(I)**3*EXP(M2)/SLOPE
5-3*DLOW18(I)**2*EXP(M2)/(SLOPE*SLOPE)
6+6*DLOW18(I)*EXP(M2)/SLOPE**3
7-6*EXP(M2)/SLOPE**4))*0.01
AMASS(ILOC) = AMASS(ILOC) +M(ILOC,I)
91 continue
C
C now that we have the total mass of water droplets in the
C sample, (amass), we can compute the percent in each class and
C the accumulated mass (liquid water content) percentage and
C the mass median diameter.
C
95 aer= 0.
do 97 i=1,9
97 accum(i)=0
C
C aer is the total effective rain rate of the sample.
C accum is the accumulated percentage mass.
write(6,104)
write(6,105) iloc,press,fset,hood,time
104 format("0" 5x," sample nozzle nozzle F "
"hood sample"/,6x,
" location number press setting "
"opening length"/,6x,
(PSI)
"(seconds)")
105 format(" ",10x, 6x,i2,15x ,f4.1,4x,f3.1,6x,f4.1,5x,f4.0)
write(6,96)
96 format("0".5x,"cate- mid num- LWC percent accum"
/,6x. "gory diameter ber/cbm (grams/ LWC percent
"
"/,6x. " (MM) N/M**3 M**3) LWC"/)
100 format(" " ,7x,i1,6x,f4.2,3x,f7.1,3x,f6.2,3x,f5.1,4x,f5.1)
do 12 i=1,9
k=i+1
percent(i) = M(ILOC,I)*100./AMASS(ILOC)
accum(k)=percent(i)+accum(k-1)
C find the class when the mass percentage goes over 50% for

```

```

c use in computing the mass median diameter.
c
      if(accum(k).ge.50..and.(accum(k)-percent(i)).lt.50.)j=i
      if(fset-1.5) 120,130,140
c er is the equivalent rain rate. the Gunn and Kinzer
c equation for terminal drop fall velocity as a function
c of diameter is used here.
c
120  er(i) = M(ILOC,I)*(-.27128+5.22306*diam12(i)-1.10757
      1*diam12(i)*diam12(i)+.11115*diam12(i)**3-.0046884*
      2diam12(i)**4)*3.6/25.4
      aer =aer+er(i)
c normalize the data into number per cubic meter
      norm(i) = N(ILOC,I)/ volume
      write(6,100) i, diam12(i),norm(i),M(ILOC,I),percent(i),accum(k)
      go to 150
130  er(i) = M(ILOC,I)*(-.27128+5.22306*diam15(i)-1.10757
      1*diam15(i)*diam15(i)+.11115*diam15(i)**3-.0046884*
      2diam15(i)**4)*3.6/25.4
      aer =aer+er(i)
c normalize the data into number per cubic meter
      norm(i) = N(ILOC,I)/ volume
      write(6,100) i, diam15(i),NORM(I),M(ILOC,I),percent(i),
      1ACCUM(K)
      go to 150
140  er(i) = M(ILOC,I)*(-.27128+5.22306*diam18(i)-1.10757
      1*diam18(i)*diam18(i)+.11115*diam18(i)**3-.0046884*
      2diam18(i)**4)*3.6/25.4
      aer =aer+er(i)
c normalize the data into number per cubic meter
      norm(i) = N(ILOC,I)/ volume
      write(6,100) i, diam18(i),NORM(I),M(ILOC,I),percent(i),accum(k)
150  continue
12  continue
      if(fset-1.5) 160,170,180
c
c compute the mass median diameter
c
160  mmd=dUP12(J-1) + (dup12(j)-dlow12(j))*(50.-accum(j))
      !/(accum(j+1)-accum(j))
      go to 190
170  mmd=dUP15(J-1) + (dup15(j)-dlow15(j))*(50.-accum(j))
      !/(accum(j+1)-accum(j))
      go to 190
180  mmd=dUP18(J-1) + (dup18(j)-dlow18(j))*(50.-accum(j))
      !/(accum(j+1)-accum(j))
190  CONTINUE
      write(6,101) AMASS(ILOC),mmd,aer
101  format(" ",5x,"total liquid water content is ",
      1f6.2," grams per cubic meter."/,5x,"the mass"
      2," median diameter is ",f4.1, "millimeters."/
      3,5x,"the equivalent natural rain rate is ",f6.1,
      4" inches per hour."////)
200  CONTINUE

```

```

C
C THIS IS PART TWO OF THE PROGRAM AND SIMPLY ADDS UP THE
C NUMBER AND MASS IN EACH SIZE BIN FOR EACH ROW. THE MMD, EQUIV.
C RAIN RATE AND OTHER PARAMETERS ARE THEN COMPUTED
C
C ISAMP IS A COUNTER FOR SAMPLE LOCATION.
  ISAMP=1
C KK IS THE ROW NUMBER.
  DO 601 KK=1,9
C ZERO ARRAYS
950  aer= 0.
      do 970 i=1,9
        TOTALM(I)=0
        TOTALN(I)=0
970  accum(i)=0
        TOTMASS=0
        DO 600 ILOC=ISAMP, (ISAMP+8)
          COUNT=COUNT+1
          DO 599 JJ=1,8
            IF(COUNT.NE.1.AND.COUNT.NE.9) GO TO 602
C ACCOUNT FOR SAMPLING ARRANGEMENT WHERE FIRST AND LAST
C SAMPLES IN ROW ARE IN THE SAME RELATIVE RAINFIELD
C POSITION BY AVERAGING THESE TWO SAMPLES.
            N(ILOC,JJ)=N(ILOC,JJ)/2.
            N(ILOC,JJ)=N(ILOC,JJ)/2.
C COMPUTE THE MASS AND NUMBER PER UNIT VOLUME IN EACH
C BIN FOR THE ROW.
600  TOTIN(ILOC)=TOTALN(JJ)+N(ILOC,JJ)/8.
          TOTALM(JJ)=TOTALM(JJ)+N(ILOC,JJ)/8.
599  CONTINUE
          IF(COUNT.NE.1.AND.COUNT.NE.9) GO TO 603
          AMASS(ILOC)=TOTMASS(ILOC)/2.
603  TOTMASS=TOTMASS+AMASS(ILOC)/8.
600  CONTINUE
C
C aer is the total effective rain rate of the sample.
C accum is the accumulated percentage mass.
      write(6,1000)
      write(6,1001)KK ,press,fset,hood,time
1000  format("  ",6x," ROW      nozzle line  F      "
1001  format("  ",6x," sample"/,6x,
2     "  ",6x," NUMBER      number press  setting "
3     "  ",6x," length"/,6x,
4     "  ",6x," (PSI)      "
5     " (inches) (seconds)")
1002  format("  ",6x,i2,15x ,f4.1,4x,f3.1,6x,f4.1,5x,f4.0)
      write(6,1003)
1003  format("  ",6x,"cate- mid num- LWC percent accum".
1004  format("  ",6x,"gory diameter ber/cbm (grams/ IWC percent
1005  format("  ",6x," (MN) N/M**3 M**3) LWC"/)
1006  format("  ",7x,i1,6x,f4.2,3x,f7.1,3x,f6.2,3x,f5.1,4x,f5.1)
      do 1007 i=1,9
        write(6,1007)
      write(6,1008)

```

```

        percent(i) = TOTALM(I)*100./TOTMASS
        accum(k)=percent(i)+accum(k-1)
c   flag the class when the mass percentage goes over 50% for
c   use in computing the mass median diameter.
c
        if(accum(k).ge.50..and.(accum(k)-percent(i)).lt.50.)j=i
        if(fset-1.5) 1200,1300,1400
1200  ER(I)= TOTALM(I)*(-.27128+5.22306*diaml2(i)-1.10757
        1*diaml2(i)*diaml2(i)+.11115*diaml2(i)**3-.0046884*
        2diaml2(i)**4)*3.6/25.4
        aer =aer+er(i)
c   normalize the data into number per cubic meter
        norm(i) = TOTALN(I)/ volume
        write(6,1000) i, diaml2(i),norm(i),TOTALM(I),percent(i),accum(k)
        go to 1500
1300  ER(I) = TOTALM(I)*(-.27128+5.22306*diaml5(i)-1.10757
        1*diaml5(i)*diaml5(i)+.11115*diaml5(i)**3-.0046884*
        2diaml5(i)**4)*3.6/25.4
        aer =aer+er(i)
c   normalize the data into number per cubic meter
        norm(i) = TOTALN(I)/ volume
        write(6,1000) i, diaml5(i),NORM(I),TOTALM(I),percent(i),
        1ACCUM(K)
        go to 1500
1400  er(i) = TOTALM(I)*(-.27128+5.22306*diaml8(i)-1.10757
        1*diaml8(i)*diaml8(i)+.11115*diaml8(i)**3-.0046884*
        2diaml8(i)**4)*3.6/25.4
        aer =aer+er(i)
c   normalize the data into number per cubic meter
        norm(i) = TOTALN(I)/ volume
        write(6,1000) i, diaml8(i),NORM(I),TOTALM(I),percent(i),accum(k)
1500  continue
1201  continue
        if(fset-1.5) 1600,1700,1800
c
c   compute the mass median diameter
c
1600  mmd=dUP12(J-1) + (dup12(j)-dlowl2(j))*(50.-accum(j))
        !/(accum(j+1)-accum(j))
        go to 1900
1700  mmd=dUP15(J-1) + (dup15(j)-dlowl5(j))*(50.-accum(j))
        !/(accum(j+1)-accum(j))
        go to 1900
1800  mmd=dUP18(J-1) + (dup18(j)-dlowl8(j))*(50.-accum(j))
        !/(accum(j+1)-accum(j))
1900  write(6,1010) TOTMASS ,mmd,aer
1010  format(" ",5x,"total liquid water content is ",
        1f6.2," grams per cubic meter."/,5x,"the mass"
        2," median diameter is ",f4.1, "millimeters."/
        3,5x,"the equivalent natural rain rate is ",f6.1,
        4" inches per hour."////)
c
c   GO TO THE NEXT ROW
        ISAMP=ISAMP+9

```

```
        COUNT=0  
601    CONTINUE  
210    stop  
      end
```



0 LOCATION: 68  
F SETTING: 1.5  
SAMPLE TIME: 300.

NOZZLE PRESSURE: 2.5  
HOOD OPENING: 3.0

|       | 0-1.0 | 1.0-1.5 | 1.5-2.1 | 2.1-2.7 | 2.7-3.3 | 3.3-3.9 | 3.9-4.5 | 4.5-5.1 |
|-------|-------|---------|---------|---------|---------|---------|---------|---------|
| 101.0 | 36.0  | 11.0    | 8.0     | .0      | .0      | .0      | .0      | .0      |
| 120.0 | 28.0  | 10.0    | 8.0     | 2.0     | 1.0     | .0      | .0      | .0      |
| 107.0 | 37.0  | 9.0     | 6.0     | 2.0     | .0      | .0      | .0      | .0      |
| 108.0 | 31.0  | 16.0    | 1.0     | 1.0     | .0      | 1.0     | .0      | .0      |
| 92.0  | 19.0  | 9.0     | .0      | 1.0     | .0      | 1.0     | .0      | .0      |
| 97.0  | 38.0  | 13.0    | 7.0     | .0      | 1.0     | .0      | .0      | .0      |
| 108.0 | 30.0  | 13.0    | 3.0     | 1.0     | 1.0     | .0      | .0      | .0      |
| 129.0 | 46.0  | 13.0    | 5.0     | 3.0     | .0      | 1.0     | .0      | .0      |
| 117.0 | 30.0  | 16.0    | 6.0     | 2.0     | .0      | 1.0     | .0      | .0      |
| 95.0  | 35.0  | 15.0    | 10.0    | .0      | .0      | .0      | .0      | .0      |
| 133.0 | 33.0  | 13.0    | 6.0     | 2.0     | .0      | .0      | .0      | .0      |
| 109.0 | 41.0  | 16.0    | 5.0     | 1.0     | .0      | .0      | .0      | .0      |
| 128.0 | 30.0  | 14.0    | 5.0     | 1.0     | .0      | .0      | .0      | .0      |
| 103.0 | 28.0  | 17.0    | 2.0     | 1.0     | 1.0     | .0      | .0      | .0      |
| 124.0 | 36.0  | 12.0    | 7.0     | 3.0     | .0      | .0      | .0      | .0      |
| 118.0 | 41.0  | 22.0    | 9.0     | .0      | .0      | .0      | .0      | .0      |
| 131.0 | 38.0  | 11.0    | 7.0     | .0      | 1.0     | .0      | .0      | .0      |
| 115.0 | 36.0  | 13.0    | 4.0     | 1.0     | .0      | .0      | .0      | .0      |

0 LOCATION: 50  
F SETTING: 1.5  
SAMPLE TIME: 300.

NOZZLE PRESSURE: 2.5  
HOOD OPENING: 3.0

|       |      |      |      |     |     |     |     |
|-------|------|------|------|-----|-----|-----|-----|
| 212.0 | 58.0 | 26.0 | 9.0  | 5.0 | 1.0 | .0  | 1.0 |
| 210.0 | 49.0 | 18.0 | 8.0  | 6.0 | 3.0 | .0  | .0  |
| 191.0 | 50.0 | 21.0 | 12.0 | 4.0 | 2.0 | .0  | .0  |
| 238.0 | 56.0 | 18.0 | 10.0 | 3.0 | 2.0 | .0  | .0  |
| 200.0 | 72.0 | 31.0 | 8.0  | 4.0 | 2.0 | 1.0 | .0  |
| 204.0 | 44.0 | 23.0 | 9.0  | 1.0 | 1.0 | .0  | .0  |
| 224.0 | 59.0 | 20.0 | 8.0  | 2.0 | .0  | 2.0 | .0  |
| 215.0 | 53.0 | 36.0 | 9.0  | 5.0 | .0  | .0  | .0  |
| 194.0 | 49.0 | 20.0 | 14.0 | .0  | .0  | .0  | 1.0 |
| 188.0 | 46.0 | 6.0  | 9.0  | 2.0 | .0  | .0  | .0  |
| 224.0 | 60.0 | 26.0 | 7.0  | 3.0 | 1.0 | .0  | 2.0 |
| 196.0 | 59.0 | 21.0 | 9.0  | 2.0 | .0  | 2.0 | 1.0 |
| 210.0 | 62.0 | 24.0 | 5.0  | 5.0 | 1.0 | .0  | .0  |
| 205.0 | 64.0 | 31.0 | 10.0 | 3.0 | 2.0 | 1.0 | .0  |
| 196.0 | 37.0 | 17.0 | 9.0  | 3.0 | 1.0 | .0  | .0  |
| 210.0 | 48.0 | 19.0 | 6.0  | 1.0 | 1.0 | 1.0 | 1.0 |
| 220.0 | 61.0 | 28.0 | 9.0  | 5.0 | 1.0 | 1.0 | .0  |
| 216.0 | 61.0 | 28.0 | 7.0  | 6.0 | 4.0 | .0  | .0  |
| 241.0 | 51.0 | 14.0 | 9.0  | 5.0 | 3.0 | .0  | 1.0 |
| 245.0 | 49.0 | 26.0 | 9.0  | 2.0 | 2.0 | 1.0 | 2.0 |
| 209.0 | 48.0 | 21.0 | 3.0  | 5.0 | 2.0 | 1.0 | .0  |
| 240.0 | 61.0 | 23.0 | 12.0 | 2.0 | 1.0 | 1.0 | .0  |
| 212.0 | 63.0 | 30.0 | 7.0  | 4.0 | .0  | 2.0 | .0  |

0 LOCATION: 77  
F SETTING: 1.5  
SAMPLE TIME: 300.

NOZZLE PRESSURE: 2.5  
HOOD OPENING: 3.0

|       |      |      |     |    |    |    |    |
|-------|------|------|-----|----|----|----|----|
| 145.0 | 33.0 | 11.0 | 9.0 | .0 | .0 | .0 | .0 |
|-------|------|------|-----|----|----|----|----|

|       |      |      |      |     |     |     |     |
|-------|------|------|------|-----|-----|-----|-----|
| 178.0 | 32.0 | 16.0 | 5.0  | 2.0 | .0  | .0  | .0  |
| 172.0 | 41.0 | 18.0 | 4.0  | .0  | .0  | .0  | .0  |
| 209.0 | 48.0 | 19.0 | 6.0  | 5.0 | .0  | 1.0 | .0  |
| 143.0 | 36.0 | 13.0 | 4.0  | 1.0 | .0  | 1.0 | .0  |
| 166.0 | 35.0 | 14.0 | 3.0  | 1.0 | .0  | .0  | .0  |
| 134.0 | 34.0 | 13.0 | 3.0  | 5.0 | 2.0 | .0  | .0  |
| 202.0 | 40.0 | 25.0 | 4.0  | 1.0 | 1.0 | .0  | .0  |
| 168.0 | 40.0 | 18.0 | 4.0  | .0  | .0  | .0  | .0  |
| 156.0 | 31.0 | 14.0 | 6.0  | .0  | 1.0 | .0  | .0  |
| 180.0 | 46.0 | 17.0 | 7.0  | 2.0 | 2.0 | 2.0 | .0  |
| 197.0 | 35.0 | 19.0 | 7.0  | 1.0 | 1.0 | .0  | .0  |
| 178.0 | 48.0 | 19.0 | 7.0  | 1.0 | .0  | .0  | .0  |
| 147.0 | 42.0 | 7.0  | 1.0  | 1.0 | .0  | .0  | .0  |
| 141.0 | 34.0 | 8.0  | 4.0  | 1.0 | 1.0 | .0  | .0  |
| 192.0 | 36.0 | 24.0 | 5.0  | 3.0 | .0  | .0  | 1.0 |
| 187.0 | 48.0 | 23.0 | 6.0  | 2.0 | 2.0 | 1.0 | .0  |
| 156.0 | 51.0 | 15.0 | 5.0  | 2.0 | .0  | .0  | .0  |
| 159.0 | 45.0 | 15.0 | 10.0 | 3.0 | 1.0 | 1.0 | .0  |
| 172.0 | 36.0 | 13.0 | 5.0  | 1.0 | .0  | .0  | .0  |
| 214.0 | 35.0 | 12.0 | 8.0  | .0  | .0  | .0  | .0  |
| 193.0 | 48.0 | 15.0 | 6.0  | 2.0 | 1.0 | 1.0 | .0  |
| 170.0 | 46.0 | 14.0 | 5.0  | .0  | 2.0 | .0  | .0  |
| 167.0 | 29.0 | 19.0 | 7.0  | 1.0 | .0  | 1.0 | .0  |
| 174.0 | 38.0 | 16.0 | 7.0  | 1.0 | .0  | .0  | .0  |
| 199.0 | 43.0 | 19.0 | 9.0  | 4.0 | .0  | .0  | 1.0 |
| 161.0 | 46.0 | 15.0 | 5.0  | 6.0 | 2.0 | .0  | .0  |

0 LOCATION: 59 NOZZLE PRESSURE: 2.5  
 F SETTING: 1.5 HOOD OPENING: 3.0  
 SAMPLE TIME: 300.

|      |      |     |     |     |     |     |    |
|------|------|-----|-----|-----|-----|-----|----|
| 29.0 | 15.0 | 6.0 | 2.0 | 1.0 | 1.0 | .0  | .0 |
| 46.0 | 16.0 | 5.0 | 3.0 | .0  | .0  | .0  | .0 |
| 41.0 | 11.0 | 6.0 | 1.0 | .0  | .0  | .0  | .0 |
| 40.0 | 12.0 | 9.0 | 2.0 | .0  | .0  | .0  | .0 |
| 32.0 | 13.0 | 7.0 | 1.0 | .0  | 1.0 | .0  | .0 |
| 28.0 | 12.0 | 1.0 | 2.0 | .0  | .0  | .0  | .0 |
| 29.0 | 21.0 | 5.0 | 4.0 | .0  | .0  | .0  | .0 |
| 35.0 | 9.0  | 5.0 | 3.0 | .0  | .0  | .0  | .0 |
| 24.0 | 11.0 | 1.0 | 2.0 | .0  | 1.0 | .0  | .0 |
| 37.0 | 19.0 | 5.0 | .0  | .0  | .0  | .0  | .0 |
| 32.0 | 9.0  | 4.0 | 1.0 | 1.0 | .0  | .0  | .0 |
| 46.0 | 12.0 | 1.0 | .0  | .0  | 1.0 | .0  | .0 |
| 38.0 | 23.0 | 1.0 | .0  | .0  | 1.0 | .0  | .0 |
| 31.0 | 10.0 | 2.0 | 2.0 | .0  | .0  | .0  | .0 |
| 38.0 | 11.0 | 4.0 | 1.0 | .0  | .0  | .0  | .0 |
| 31.0 | 11.0 | 1.0 | 1.0 | .0  | .0  | .0  | .0 |
| 25.0 | 11.0 | 5.0 | 0.0 | 1.0 | .0  | .0  | .0 |
| 43.0 | 13.0 | 9.0 | .0  | .0  | .0  | .0  | .0 |
| 44.0 | 13.0 | 2.0 | .0  | .0  | .0  | .0  | .0 |
| 44.0 | 14.0 | 1.0 | 1.0 | 2.0 | .0  | .0  | .0 |
| 37.0 | 14.0 | 1.0 | 1.0 | .0  | .0  | 1.0 | .0 |

0 LOCATION: 4 NOZZLE PRESSURE: 2.5  
 F SETTING: 1.5 HOOD OPENING: 3.0  
 SAMPLE TIME: 300.

|       |      |      |      |     |     |     |     |
|-------|------|------|------|-----|-----|-----|-----|
| 180.0 | 48.0 | 13.0 | 9.0  | 3.0 | .0  | .0  | .0  |
| 206.0 | 58.0 | 17.0 | 6.0  | 4.0 | .0  | .0  | .0  |
| 170.0 | 45.0 | 15.0 | 8.0  | 2.0 | 1.0 | .0  | .0  |
| 191.0 | 53.0 | 20.0 | 13.0 | 3.0 | .0  | .0  | .0  |
| 192.0 | 44.0 | 15.0 | 6.0  | 4.0 | 1.0 | 1.0 | .0  |
| 189.0 | 47.0 | 23.0 | 9.0  | 3.0 | 2.0 | 2.0 | .0  |
| 188.0 | 55.0 | 21.0 | 11.0 | 2.0 | .0  | .0  | .0  |
| 197.0 | 40.0 | 18.0 | 9.0  | 3.0 | .0  | .0  | .0  |
| 154.0 | 51.0 | 13.0 | 11.0 | 1.0 | 2.0 | .0  | .0  |
| 173.0 | 35.0 | 21.0 | 7.0  | 1.0 | 1.0 | 2.0 | .0  |
| 174.0 | 50.0 | 16.0 | 8.0  | 2.0 | 2.0 | .0  | .0  |
| 195.0 | 54.0 | 21.0 | 10.0 | 2.0 | 2.0 | .0  | .0  |
| 181.0 | 67.0 | 17.0 | 9.0  | 6.0 | 2.0 | 1.0 | 2.0 |
| 185.0 | 54.0 | 23.0 | 6.0  | 4.0 | 3.0 | 1.0 | .0  |
| 231.0 | 69.0 | 15.0 | 7.0  | 2.0 | 1.0 | 2.0 | .0  |
| 188.0 | 42.0 | 19.0 | 7.0  | 7.0 | .0  | .0  | .0  |
| 189.0 | 44.0 | 18.0 | 8.0  | 4.0 | 3.0 | .0  | .0  |
| 212.0 | 54.0 | 13.0 | 7.0  | 1.0 | 2.0 | 2.0 | .0  |
| 162.0 | 47.0 | 15.0 | 6.0  | 1.0 | 1.0 | 1.0 | 2.0 |
| 181.0 | 46.0 | 21.0 | 7.0  | 7.0 | 2.0 | 2.0 | .0  |
| 175.0 | 39.0 | 20.0 | 6.0  | 4.0 | 3.0 | .0  | .0  |
| 196.0 | 57.0 | 31.0 | 6.0  | 2.0 | 1.0 | .0  | .0  |
| 164.0 | 58.0 | 21.0 | 5.0  | 2.0 | 3.0 | 1.0 | 1.0 |
| 188.0 | 56.0 | 18.0 | 7.0  | 1.0 | 2.0 | .0  | .0  |
| 169.0 | 41.0 | 24.0 | 9.0  | 4.0 | 1.0 | 1.0 | 1.0 |
| 176.0 | 42.0 | 18.0 | 7.0  | 3.0 | .0  | 1.0 | .0  |
| 181.0 | 41.0 | 14.0 | 13.0 | 2.0 | 1.0 | .0  | .0  |

0 LOCATION: 14 NOZZLE PRESSURE: 2.5  
 F SETTING: 1.5 HOOD OPENING: 3.0  
 SAMPLE TIME: 300.

|         |      |      |      |      |     |     |     |
|---------|------|------|------|------|-----|-----|-----|
| 254.0   | 65.0 | 26.0 | 15.0 | 6.0  | 3.0 | 1.0 | .0  |
| 250.0   | 83.0 | 20.0 | 14.0 | 7.0  | 4.0 | .0  | .0  |
| 312.0   | 58.0 | 26.0 | 13.0 | 7.0  | 3.0 | 1.0 | 1.0 |
| 297.0   | 81.0 | 23.0 | 13.0 | 6.0  | 6.0 | 2.0 | .0  |
| 267.0   | 69.0 | 20.0 | 8.0  | 4.0  | 4.0 | 1.0 | .0  |
| 308.0   | 59.0 | 26.0 | 11.0 | 6.0  | 4.0 | 3.0 | .0  |
| 299.0   | 81.0 | 23.0 | 16.0 | 5.0  | 8.0 | 1.0 | .0  |
| 295.0   | 76.0 | 27.0 | 14.0 | 5.0  | 1.0 | .0  | .0  |
| 295.0   | 55.0 | 24.0 | 12.0 | 11.0 | 3.0 | 1.0 | .0  |
| 319.0   | 78.0 | 29.0 | 15.0 | 8.0  | 4.0 | 3.0 | 1.0 |
| 278.0   | 64.0 | 29.0 | 14.0 | 9.0  | 5.0 | .0  | .0  |
| 259.0   | 62.0 | 21.0 | 9.0  | 8.0  | 1.0 | .0  | .0  |
| 279.0   | 82.0 | 22.0 | 13.0 | 9.0  | 3.0 | .0  | .0  |
| 267.0   | 82.0 | 30.0 | 12.0 | 8.0  | 4.0 | 1.0 | .0  |
| 231.0   | 61.0 | 25.0 | 13.0 | 6.0  | 1.0 | .0  | 2.0 |
| 287.0   | 71.0 | 22.0 | 9.0  | 13.0 | 6.0 | 2.0 | .0  |
| * 283.0 | 70.0 | 36.0 | 13.0 | 9.0  | .0  | 2.0 | 3.0 |
| 266.0   | 64.0 | 23.0 | 6.0  | 7.0  | .0  | .0  | .0  |
| 273.0   | 83.0 | 24.0 | 16.0 | 8.0  | 1.0 | .0  | 1.0 |
| 275.0   | 59.0 | 23.0 | 12.0 | 2.0  | 4.0 | 2.0 | .0  |
| 278.0   | 61.0 | 27.0 | 11.0 | 3.0  | 3.0 | 2.0 | 1.0 |
| 268.0   | 60.0 | 23.0 | 14.0 | 2.0  | 2.0 | 2.0 | .0  |
| 307.0   | 68.0 | 30.0 | 11.0 | 8.0  | 2.0 | .0  | 1.0 |
| 256.0   | 55.0 | 23.0 | 10.0 | 4.0  | 1.0 | .0  | 2.0 |
| 284.0   | 67.0 | 34.0 | 11.0 | 7.0  | 2.0 | 3.0 | 1.0 |

|       |      |      |      |     |     |     |     |
|-------|------|------|------|-----|-----|-----|-----|
| 258.0 | 69.0 | 26.0 | 8.0  | 8.0 | 1.0 | 2.0 | .0  |
| 261.0 | 71.0 | 26.0 | 6.0  | 3.0 | 2.0 | .0  | 1.0 |
| 257.0 | 55.0 | 26.0 | 12.0 | 7.0 | 3.0 | 4.0 | .0  |

0 LOCATION: 7 NOZZLE PRESSURE: 2.5  
 F SETTING: 1.5 HOOD OPENING: 3.0  
 SAMPLE TIME: 300.

|       |      |      |      |      |     |     |     |
|-------|------|------|------|------|-----|-----|-----|
| 264.0 | 66.0 | 17.0 | 10.0 | 6.0  | 3.0 | 2.0 | .0  |
| 274.0 | 62.0 | 21.0 | 12.0 | 12.0 | 5.0 | .0  | .0  |
| 230.0 | 64.0 | 18.0 | 14.0 | 5.0  | 4.0 | .0  | 1.0 |
| 223.0 | 63.0 | 24.0 | 13.0 | 6.0  | 4.0 | 2.0 | 2.0 |
| 247.0 | 52.0 | 20.0 | 7.0  | 9.0  | 2.0 | 4.0 | 3.0 |
| 268.0 | 59.0 | 35.0 | 10.0 | 8.0  | 3.0 | 1.0 | 1.0 |
| 241.0 | 78.0 | 26.0 | 20.0 | 7.0  | 9.0 | 2.0 | 1.0 |
| 239.0 | 71.0 | 11.0 | 9.0  | 2.0  | 4.0 | 2.0 | 2.0 |
| 238.0 | 62.0 | 23.0 | 12.0 | 6.0  | 3.0 | .0  | 2.0 |
| 230.0 | 66.0 | 31.0 | 12.0 | 11.0 | 1.0 | 1.0 | .0  |
| 245.0 | 44.0 | 36.0 | 13.0 | 7.0  | 5.0 | 4.0 | .0  |
| 251.0 | 46.0 | 20.0 | 6.0  | 5.0  | 4.0 | .0  | .0  |
| 259.0 | 68.0 | 27.0 | 8.0  | 4.0  | 2.0 | 3.0 | 2.0 |
| 247.0 | 62.0 | 24.0 | 10.0 | 4.0  | 2.0 | 2.0 | 3.0 |
| 241.0 | 68.0 | 20.0 | 15.0 | 5.0  | 2.0 | 4.0 | .0  |
| 207.0 | 56.0 | 30.0 | 9.0  | 5.0  | 4.0 | 1.0 | .0  |
| 230.0 | 67.0 | 9.0  | 12.0 | 3.0  | 3.0 | 3.0 | 1.0 |
| 283.0 | 78.0 | 36.0 | 10.0 | 9.0  | 6.0 | 5.0 | .0  |
| 258.0 | 74.0 | 25.0 | 10.0 | 9.0  | 1.0 | 2.0 | 2.0 |
| 235.0 | 51.0 | 22.0 | 11.0 | 5.0  | 2.0 | 3.0 | 1.0 |
| 256.0 | 39.0 | 24.0 | 17.0 | 3.0  | 4.0 | 1.0 | 1.0 |
| 227.0 | 81.0 | 24.0 | 16.0 | 5.0  | 3.0 | 2.0 | 1.0 |
| 243.0 | 53.0 | 26.0 | 11.0 | 5.0  | 5.0 | 1.0 | .0  |
| 234.0 | 66.0 | 21.0 | 14.0 | 7.0  | 5.0 | 2.0 | 2.0 |
| 222.0 | 58.0 | 20.0 | 18.0 | 8.0  | 1.0 | 2.0 | 2.0 |

0 LOCATION: 34 NOZZLE PRESSURE: 2.5  
 F SETTING: 1.5 HOOD OPENING: 3.0  
 SAMPLE TIME: 300.

|       |      |      |      |      |     |     |     |
|-------|------|------|------|------|-----|-----|-----|
| 327.0 | 82.0 | 41.0 | 10.0 | 11.0 | 7.0 | 2.0 | 1.0 |
| 342.0 | 74.0 | 23.0 | 14.0 | 13.0 | 5.0 | 1.0 | 2.0 |
| 280.0 | 66.0 | 26.0 | 12.0 | 9.0  | 7.0 | 1.0 | 1.0 |
| 287.0 | 46.0 | 21.0 | 13.0 | 12.0 | 6.0 | 1.0 | 2.0 |
| 329.0 | 68.0 | 21.0 | 12.0 | 6.0  | 4.0 | 2.0 | 2.0 |
| 312.0 | 76.0 | 31.0 | 12.0 | 8.0  | 6.0 | 3.0 | 1.0 |
| 305.0 | 82.0 | 28.0 | 13.0 | 7.0  | 7.0 | 7.0 | 3.0 |
| 328.0 | 51.0 | 37.0 | 15.0 | 11.0 | 2.0 | 1.0 | 2.0 |
| 300.0 | 81.0 | 21.0 | 12.0 | 7.0  | 2.0 | 2.0 | 2.0 |
| 320.0 | 78.0 | 30.0 | 13.0 | 4.0  | 2.0 | 1.0 | 1.0 |
| 315.0 | 64.0 | 34.0 | 12.0 | 7.0  | 3.0 | 2.0 | 4.0 |
| 293.0 | 83.0 | 38.0 | 12.0 | 8.0  | 4.0 | 1.0 | 1.0 |
| 342.0 | 81.0 | 28.0 | 14.0 | 2.0  | 4.0 | 2.0 | .0  |
| 310.0 | 78.0 | 29.0 | 9.0  | 19.0 | 3.0 | 5.0 | .0  |
| 292.0 | 62.0 | 31.0 | 10.0 | 10.0 | 2.0 | 3.0 | 1.0 |
| 273.0 | 88.0 | 28.0 | 12.0 | 3.0  | 6.0 | 3.0 | 2.0 |
| 362.0 | 66.0 | 11.0 | 24.0 | 8.0  | 5.0 | 3.0 | .0  |
| 360.0 | 72.0 | 38.0 | 12.0 | 9.0  | 2.0 | 3.0 | 5.0 |
| 345.0 | 61.0 | 21.0 | 12.0 | 4.0  | 4.0 | 2.0 | .0  |

|       |       |      |      |      |     |     |     |
|-------|-------|------|------|------|-----|-----|-----|
| 326.0 | 91.0  | 22.0 | 9.0  | 7.0  | 6.0 | 3.0 | 2.0 |
| 306.0 | 64.0  | 30.0 | 9.0  | 4.0  | 5.0 | 2.0 | .0  |
| 291.0 | 66.0  | 20.0 | 4.0  | 5.0  | 3.0 | .0  | 3.0 |
| 292.0 | 109.0 | 28.0 | 14.0 | 10.0 | 3.0 | 3.0 | 2.0 |
| 327.0 | 85.0  | 35.0 | 19.0 | 7.0  | 4.0 | 3.0 | 2.0 |
| 320.0 | 80.0  | 17.0 | 10.0 | 3.0  | 4.0 | 3.0 | 1.0 |
| 367.0 | 80.0  | 32.0 | 9.0  | 5.0  | 7.0 | 3.0 | 1.0 |
| 385.0 | 80.0  | 29.0 | 16.0 | 5.0  | 5.0 | .0  | 2.0 |
| 334.0 | 80.0  | 34.0 | 9.0  | 8.0  | 3.0 | .0  | 1.0 |

0 LOCATION: 61 NOZZLE PRESSURE: 2.5  
 F SETTING: 1.5 HOOD OPENING: 3.0  
 SAMPLE TIME: 300.

|       |       |      |      |      |      |     |     |
|-------|-------|------|------|------|------|-----|-----|
| 233.0 | 74.0  | 32.0 | 12.0 | 12.0 | 7.0  | .0  | .0  |
| 234.0 | 61.0  | 26.0 | 11.0 | 7.0  | 4.0  | 2.0 | 2.0 |
| 262.0 | 56.0  | 23.0 | 17.0 | 12.0 | 5.0  | 3.0 | 2.0 |
| 253.0 | 76.0  | 24.0 | 12.0 | 7.0  | 2.0  | 1.0 | 1.0 |
| 214.0 | 51.0  | 25.0 | 10.0 | 9.0  | 1.0  | 3.0 | 2.0 |
| 292.0 | 65.0  | 31.0 | 7.0  | 7.0  | 2.0  | 6.0 | 1.0 |
| 242.0 | 74.0  | 30.0 | 13.0 | 5.0  | 6.0  | 3.0 | 3.0 |
| 287.0 | 66.0  | 33.0 | 14.0 | 5.0  | 11.0 | 3.0 | .0  |
| 274.0 | 53.0  | 25.0 | 14.0 | 5.0  | 3.0  | 3.0 | 1.0 |
| 250.0 | 60.0  | 30.0 | 8.0  | 5.0  | 5.0  | 1.0 | 1.0 |
| 221.0 | 58.0  | 18.0 | 11.0 | 12.0 | 1.0  | 5.0 | 2.0 |
| 312.0 | 103.0 | 32.0 | 17.0 | 5.0  | 6.0  | 2.0 | 3.0 |
| 239.0 | 59.0  | 18.0 | 10.0 | 7.0  | 4.0  | 1.0 | 1.0 |
| 254.0 | 52.0  | 30.0 | 18.0 | 8.0  | 4.0  | .0  | .0  |
| 271.0 | 49.0  | 26.0 | 13.0 | 6.0  | 1.0  | 6.0 | 3.0 |
| 230.0 | 67.0  | 32.0 | 13.0 | 6.0  | 3.0  | 2.0 | .0  |
| 309.0 | 78.0  | 27.0 | 17.0 | 5.0  | 9.0  | .0  | .0  |
| 261.0 | 73.0  | 37.0 | 9.0  | 7.0  | 5.0  | 3.0 | .0  |
| 288.0 | 62.0  | 25.0 | 18.0 | 8.0  | 6.0  | 2.0 | .0  |
| 257.0 | 62.0  | 25.0 | 13.0 | 4.0  | 1.0  | 2.0 | .0  |
| 271.0 | 63.0  | 25.0 | 17.0 | 6.0  | 5.0  | 4.0 | 1.0 |
| 286.0 | 69.0  | 29.0 | 10.0 | 3.0  | 3.0  | 4.0 | 1.0 |
| 311.0 | 93.0  | 31.0 | 19.0 | 4.0  | 4.0  | 3.0 | .0  |
| 269.0 | 49.0  | 22.0 | 7.0  | 12.0 | 2.0  | 5.0 | .0  |
| 252.0 | 69.0  | 22.0 | 14.0 | 5.0  | 1.0  | .0  | .0  |
| 293.0 | 81.0  | 25.0 | 23.0 | 10.0 | 6.0  | 4.0 | 2.0 |
| 305.0 | 67.0  | 31.0 | 15.0 | 8.0  | 2.0  | 2.0 | .0  |
| 243.0 | 61.0  | 26.0 | 20.0 | 7.0  | 2.0  | 2.0 | 2.0 |
| 275.0 | 75.0  | 20.0 | 13.0 | 8.0  | 11.0 | 2.0 | 2.0 |

0 LOCATION: 70 NOZZLE PRESSURE: 2.5  
 F SETTING: 1.5 HOOD OPENING: 3.0  
 SAMPLE TIME: 300.

|       |      |      |      |     |     |     |     |
|-------|------|------|------|-----|-----|-----|-----|
| 358.0 | 59.0 | 25.0 | 13.0 | 1.0 | 1.0 | 1.0 | 1.0 |
| 315.0 | 59.0 | 28.0 | 5.0  | 3.0 | 3.0 | 2.0 | .0  |
| 343.0 | 57.0 | 29.0 | 10.0 | 5.0 | 2.0 | 2.0 | 2.0 |
| 347.0 | 63.0 | 24.0 | 13.0 | 4.0 | 1.0 | .0  | .0  |
| 420.0 | 88.0 | 37.0 | 12.0 | 4.0 | 1.0 | 2.0 | .0  |
| 298.0 | 79.0 | 33.0 | 5.0  | 5.0 | 2.0 | .0  | 1.0 |
| 310.0 | 56.0 | 22.0 | 9.0  | 3.0 | 3.0 | 1.0 | .0  |
| 299.0 | 76.0 | 15.0 | 11.0 | 6.0 | 4.0 | 1.0 | 2.0 |
| 293.0 | 66.0 | 23.0 | 10.0 | 3.0 | .0  | 2.0 | .0  |

|       |      |      |      |     |     |     |     |
|-------|------|------|------|-----|-----|-----|-----|
| 302.0 | 55.0 | 23.0 | 12.0 | 4.0 | 4.0 | .0  | 3.0 |
| 277.0 | 53.0 | 18.0 | 12.0 | 2.0 | 1.0 | .0  | 1.0 |
| 292.0 | 54.0 | 24.0 | 7.0  | 4.0 | 2.0 | .0  | 1.0 |
| 339.0 | 61.0 | 27.0 | 15.0 | 8.0 | 3.0 | 1.0 | .0  |
| 312.0 | 63.0 | 27.0 | 9.0  | 6.0 | 2.0 | .0  | 1.0 |
| 330.0 | 63.0 | 34.0 | 15.0 | 5.0 | 3.0 | .0  | .0  |
| 359.0 | 61.0 | 32.0 | 12.0 | 5.0 | 2.0 | 4.0 | 2.0 |
| 375.0 | 58.0 | 26.0 | 10.0 | 4.0 | 1.0 | 3.0 | 1.0 |
| 343.0 | 74.0 | 26.0 | 6.0  | 7.0 | 1.0 | 1.0 | .0  |
| 362.0 | 64.0 | 24.0 | 8.0  | 3.0 | 1.0 | 2.0 | .0  |
| 295.0 | 61.0 | 29.0 | 12.0 | 6.0 | 3.0 | 1.0 | 2.0 |
| 373.0 | 60.0 | 25.0 | 8.0  | 2.0 | .0  | 3.0 | .0  |
| 347.0 | 70.0 | 32.0 | 11.0 | 4.0 | 1.0 | 2.0 | .0  |
| 370.0 | 69.0 | 30.0 | 6.0  | 4.0 | 1.0 | 1.0 | .0  |
| 315.0 | 65.0 | 19.0 | 14.0 | 1.0 | 2.0 | .0  | .0  |
| 341.0 | 57.0 | 30.0 | 13.0 | 1.0 | 4.0 | 2.0 | .0  |
| 315.0 | 74.0 | 21.0 | 10.0 | 6.0 | 2.0 | 1.0 | 1.0 |

0 LOCATION: 43 NOZZLE PRESSURE: 2.5  
 F. SETTING: 1.5 HOOD OPENING: 3.0  
 SAMPLE TIME: 200.

|       |      |      |      |     |     |     |     |
|-------|------|------|------|-----|-----|-----|-----|
| 295.0 | 38.0 | 10.0 | 6.0  | 2.0 | 1.0 | 1.0 | .0  |
| 298.0 | 54.0 | 19.0 | 5.0  | 3.0 | .0  | .0  | .0  |
| 248.0 | 43.0 | 8.0  | 9.0  | 2.0 | 1.0 | .0  | .0  |
| 327.0 | 60.0 | 19.0 | 13.0 | 7.0 | 2.0 | .0  | .0  |
| 291.0 | 48.0 | 7.0  | 3.0  | 3.0 | .0  | 1.0 | 1.0 |
| 258.0 | 47.0 | 20.0 | 9.0  | 2.0 | 1.0 | 1.0 | .0  |
| 283.0 | 55.0 | 19.0 | 9.0  | 4.0 | 4.0 | .0  | 1.0 |
| 281.0 | 44.0 | 10.0 | 6.0  | 2.0 | 2.0 | 1.0 | .0  |
| 249.0 | 40.0 | 18.0 | 4.0  | 4.0 | 3.0 | .0  | 2.0 |
| 240.0 | 42.0 | 15.0 | 5.0  | 2.0 | 1.0 | .0  | .0  |
| 267.0 | 43.0 | 20.0 | 11.0 | 2.0 | 3.0 | .0  | .0  |
| 277.0 | 56.0 | 16.0 | 8.0  | .0  | 1.0 | 4.0 | .0  |
| 301.0 | 37.0 | 16.0 | 10.0 | 4.0 | .0  | .0  | 1.0 |
| 244.0 | 39.0 | 11.0 | 8.0  | 3.0 | 1.0 | 1.0 | .0  |
| 302.0 | 46.0 | 17.0 | 7.0  | 5.0 | 2.0 | .0  | .0  |
| 250.0 | 45.0 | 16.0 | 7.0  | 1.0 | 2.0 | .0  | 1.0 |
| 260.0 | 44.0 | 16.0 | 7.0  | 4.0 | 1.0 | .0  | .0  |
| 235.0 | 45.0 | 15.0 | 7.0  | 5.0 | .0  | 1.0 | 1.0 |
| 241.0 | 37.0 | 18.0 | 7.0  | 1.0 | 1.0 | 2.0 | .0  |
| 276.0 | 45.0 | 11.0 | 7.0  | 4.0 | 7.0 | 1.0 | .0  |
| 292.0 | 45.0 | 11.0 | 7.0  | 5.0 | 1.0 | .0  | .0  |
| 244.0 | 45.0 | 11.0 | 7.0  | 2.0 | .0  | .0  | .0  |
| 303.0 | 45.0 | 6.0  | 7.0  | 3.0 | .0  | .0  | .0  |
| 230.0 | 45.0 | 9.0  | 2.0  | 4.0 | 1.0 | 1.0 | .0  |
| 244.0 | 45.0 | 11.0 | 7.0  | 2.0 | 1.0 | 1.0 | 1.0 |

0 LOCATION: 43 NOZZLE PRESSURE: 2.5  
 F. SETTING: 1.5 HOOD OPENING: 3.0  
 SAMPLE TIME: 200.

|       |      |      |      |     |     |     |     |
|-------|------|------|------|-----|-----|-----|-----|
| 302.0 | 55.0 | 23.0 | 12.0 | 4.0 | 4.0 | .0  | 3.0 |
| 277.0 | 53.0 | 18.0 | 12.0 | 2.0 | 1.0 | .0  | 1.0 |
| 292.0 | 54.0 | 24.0 | 7.0  | 4.0 | 2.0 | .0  | 1.0 |
| 339.0 | 61.0 | 27.0 | 15.0 | 8.0 | 3.0 | 1.0 | .0  |
| 312.0 | 63.0 | 27.0 | 9.0  | 6.0 | 2.0 | .0  | 1.0 |
| 330.0 | 63.0 | 34.0 | 15.0 | 5.0 | 3.0 | .0  | .0  |
| 359.0 | 61.0 | 32.0 | 12.0 | 5.0 | 2.0 | 4.0 | 2.0 |
| 375.0 | 58.0 | 26.0 | 10.0 | 4.0 | 1.0 | 3.0 | 1.0 |
| 343.0 | 74.0 | 26.0 | 6.0  | 7.0 | 1.0 | 1.0 | .0  |
| 362.0 | 64.0 | 24.0 | 8.0  | 3.0 | 1.0 | 2.0 | .0  |
| 295.0 | 61.0 | 29.0 | 12.0 | 6.0 | 3.0 | 1.0 | 2.0 |
| 373.0 | 60.0 | 25.0 | 8.0  | 2.0 | .0  | 3.0 | .0  |
| 347.0 | 70.0 | 32.0 | 11.0 | 4.0 | 1.0 | 2.0 | .0  |
| 370.0 | 69.0 | 30.0 | 6.0  | 4.0 | 1.0 | 1.0 | .0  |
| 315.0 | 65.0 | 19.0 | 14.0 | 1.0 | 2.0 | .0  | .0  |
| 341.0 | 57.0 | 30.0 | 13.0 | 1.0 | 4.0 | 2.0 | .0  |
| 315.0 | 74.0 | 21.0 | 10.0 | 6.0 | 2.0 | 1.0 | 1.0 |

|       |      |      |      |      |     |     |     |
|-------|------|------|------|------|-----|-----|-----|
| 353.0 | 63.0 | 19.0 | 13.0 | 3.0  | 5.0 | 1.0 | .0  |
| 318.0 | 78.0 | 25.0 | 14.0 | 2.0  | 3.0 | 2.0 | 1.0 |
| 355.0 | 63.0 | 27.0 | 11.0 | 10.0 | 4.0 | 1.0 | 1.0 |
| 382.0 | 66.0 | 30.0 | 4.0  | 3.0  | 3.0 | 1.0 | .0  |
| 362.0 | 66.0 | 26.0 | 13.0 | 4.0  | 5.0 | .0  | .0  |
| 332.0 | 68.0 | 15.0 | 4.0  | 6.0  | .0  | 1.0 | .0  |
| 326.0 | 60.0 | 35.0 | 16.0 | 5.0  | 1.0 | 2.0 | 1.0 |
| 384.0 | 70.0 | 22.0 | 13.0 | 1.0  | 3.0 | 2.0 | 2.0 |
| 359.0 | 68.0 | 23.0 | 6.0  | 9.0  | 3.0 | 1.0 | .0  |
| 374.0 | 73.0 | 23.0 | 7.0  | 7.0  | 2.0 | 3.0 | 1.0 |
| 331.0 | 70.0 | 17.0 | 16.0 | 4.0  | 3.0 | 2.0 | .0  |
| 358.0 | 66.0 | 26.0 | 8.0  | 2.0  | 5.0 | .0  | 1.0 |
| 358.0 | 44.0 | 27.0 | 7.0  | 6.0  | 2.0 | 2.0 | 1.0 |
| 293.0 | 66.0 | 22.0 | 6.0  | 7.0  | 3.0 | 1.0 | .0  |
| 343.0 | 74.0 | 19.0 | 23.0 | 4.0  | 4.0 | 1.0 | .0  |
| 363.0 | 82.0 | 26.0 | 6.0  | 6.0  | 3.0 | 2.0 | 1.0 |
| 379.0 | 65.0 | 19.0 | 9.0  | 7.0  | 1.0 | 2.0 | .0  |
| 345.0 | 67.0 | 25.0 | 8.0  | 4.0  | 2.0 | .0  | 1.0 |
| 362.0 | 69.0 | 15.0 | 5.0  | 3.0  | 2.0 | .0  | 1.0 |
| 359.0 | 60.0 | 30.0 | 14.0 | 7.0  | 6.0 | 4.0 | 2.0 |
| 355.0 | 83.0 | 16.0 | 3.0  | 4.0  | 4.0 | 2.0 | .0  |

0 LOCATION: 16 NOZZLE PRESSURE: 2.5  
 F SETTING: 1.5 HOOD OPENING: 3.0  
 SAMPLE TIME: 300.

|       |      |      |     |     |     |     |     |
|-------|------|------|-----|-----|-----|-----|-----|
| 149.0 | 33.0 | 8.0  | 8.0 | 2.0 | 1.0 | .0  | .0  |
| 222.0 | 42.0 | 10.0 | 4.0 | 1.0 | .0  | 1.0 | .0  |
| 227.0 | 37.0 | 12.0 | 6.0 | 4.0 | 1.0 | 1.0 | 1.0 |
| 189.0 | 24.0 | 8.0  | 6.0 | 3.0 | 2.0 | 1.0 | .0  |
| 180.0 | 33.0 | 10.0 | 2.0 | 2.0 | .0  | .0  | .0  |
| 205.0 | 28.0 | 15.0 | 9.0 | 1.0 | .0  | .0  | .0  |
| 179.0 | 31.0 | 9.0  | 3.0 | 2.0 | 2.0 | .0  | .0  |
| 188.0 | 42.0 | 10.0 | 6.0 | 2.0 | 1.0 | 1.0 | .0  |
| 226.0 | 28.0 | 13.0 | 4.0 | 3.0 | .0  | .0  | .0  |
| 205.0 | 39.0 | 16.0 | 4.0 | .0  | .0  | .0  | .0  |
| 248.0 | 34.0 | 7.0  | 1.0 | 3.0 | 1.0 | .0  | .0  |
| 223.0 | 35.0 | 7.0  | 3.0 | .0  | .0  | .0  | .0  |
| 236.0 | 27.0 | 6.0  | 4.0 | .0  | .0  | .0  | .0  |
| 185.0 | 30.0 | 8.0  | 4.0 | 4.0 | .0  | .0  | .0  |
| 231.0 | 44.0 | 11.0 | 9.0 | 2.0 | .0  | .0  | 1.0 |
| 216.0 | 30.0 | 11.0 | 4.0 | 1.0 | .0  | .0  | .0  |
| 229.0 | 40.0 | 10.0 | 4.0 | 2.0 | .0  | .0  | .0  |
| 179.0 | 23.0 | 15.0 | 3.0 | .0  | .0  | .0  | .0  |
| 227.0 | 48.0 | 14.0 | 1.0 | 1.0 | .0  | 1.0 | .0  |
| 187.0 | 34.0 | 8.0  | 9.0 | 3.0 | .0  | .0  | .0  |
| 141.0 | 31.0 | 13.0 | 3.0 | 3.0 | .0  | 1.0 | .0  |
| 178.0 | 40.0 | 16.0 | 2.0 | 1.0 | .0  | .0  | .0  |
| 234.0 | 39.0 | 10.0 | 4.0 | 4.0 | 3.0 | .0  | .0  |
| 182.0 | 27.0 | 11.0 | 4.0 | 1.0 | 1.0 | 1.0 | .0  |
| 195.0 | 42.0 | 17.0 | 1.0 | 4.0 | 4.0 | .0  | .0  |
| 228.0 | 23.0 | 7.0  | 1.0 | .0  | 1.0 | .0  | .0  |

0 LOCATION: 15 NOZZLE PRESSURE: 2.5  
 F SETTING: 1.5 HOOD OPENING: 3.0  
 SAMPLE TIME: 300.

|       |      |      |      |     |     |     |     |
|-------|------|------|------|-----|-----|-----|-----|
| 339.0 | 44.0 | 19.0 | 9.0  | 9.0 | 3.0 | .0  | 1.0 |
| 376.0 | 55.0 | 17.0 | 11.0 | 8.0 | 4.0 | 1.0 | .0  |
| 323.0 | 60.0 | 20.0 | 12.0 | 5.0 | 2.0 | 2.0 | 1.0 |
| 292.0 | 69.0 | 30.0 | 11.0 | 5.0 | .0  | 2.0 | 1.0 |
| 320.0 | 58.0 | 11.0 | 7.0  | 2.0 | 4.0 | 1.0 | .0  |
| 331.0 | 64.0 | 21.0 | 5.0  | 1.0 | 3.0 | 5.0 | .0  |
| 379.0 | 53.0 | 25.0 | 7.0  | 6.0 | 3.0 | .0  | .0  |
| 304.0 | 44.0 | 13.0 | 9.0  | 1.0 | 2.0 | 1.0 | .0  |
| 328.0 | 54.0 | 28.0 | 5.0  | 1.0 | 3.0 | .0  | .0  |
| 277.0 | 51.0 | 19.0 | 10.0 | 4.0 | 1.0 | 2.0 | .0  |
| 364.0 | 61.0 | 23.0 | 13.0 | 4.0 | 3.0 | .0  | 1.0 |
| 337.0 | 49.0 | 15.0 | 10.0 | 3.0 | 4.0 | .0  | .0  |
| 290.0 | 49.0 | 16.0 | 12.0 | 3.0 | 3.0 | .0  | .0  |
| 369.0 | 55.0 | 25.0 | 9.0  | 4.0 | 1.0 | 1.0 | 2.0 |
| 324.0 | 58.0 | 19.0 | 5.0  | 3.0 | 1.0 | .0  | 1.0 |
| 346.0 | 54.0 | 23.0 | 7.0  | 2.0 | 3.0 | .0  | .0  |
| 342.0 | 55.0 | 14.0 | 12.0 | 4.0 | 1.0 | .0  | 3.0 |
| 358.0 | 52.0 | 23.0 | 13.0 | 4.0 | 2.0 | 2.0 | .0  |
| 355.0 | 51.0 | 21.0 | 6.0  | 5.0 | 2.0 | 2.0 | .0  |
| 326.0 | 46.0 | 18.0 | 13.0 | 2.0 | 1.0 | 3.0 | .0  |
| 323.0 | 49.0 | 24.0 | 6.0  | 5.0 | 3.0 | 1.0 | .0  |
| 355.0 | 44.0 | 20.0 | 6.0  | 7.0 | 2.0 | 2.0 | 1.0 |
| 333.0 | 61.0 | 25.0 | 11.0 | 4.0 | 2.0 | 2.0 | 1.0 |
| 317.0 | 61.0 | 20.0 | 13.0 | 3.0 | 3.0 | .0  | .0  |
| 305.0 | 48.0 | 22.0 | 8.0  | 5.0 | 1.0 | 4.0 | 2.0 |
| 342.0 | 69.0 | 19.0 | 10.0 | 3.0 | .0  | 2.0 | 1.0 |

0 LOCATION: P4 NOZZLE PRESSURE: 2.5  
 F SETTING: 115 HOOD OPENING: 3.0  
 SAMPLE TIME: 300.

|       |      |      |      |      |     |     |     |
|-------|------|------|------|------|-----|-----|-----|
| 418.0 | 78.0 | 26.0 | 14.0 | 4.0  | 4.0 | 3.0 | 1.0 |
| 372.0 | 75.0 | 18.0 | 10.0 | 1.0  | 5.0 | 5.0 | .0  |
| 426.0 | 64.0 | 23.0 | 7.0  | 4.0  | 2.0 | 1.0 | .0  |
| 434.0 | 59.0 | 22.0 | 9.0  | 2.0  | 3.0 | 1.0 | 1.0 |
| 411.0 | 72.0 | 23.0 | 10.0 | 3.0  | 1.0 | 3.0 | .0  |
| 418.0 | 74.0 | 21.0 | 10.0 | 4.0  | 3.0 | 3.0 | .0  |
| 315.0 | 75.0 | 18.0 | 5.0  | 4.0  | 3.0 | 1.0 | 2.0 |
| 414.0 | 79.0 | 19.0 | 11.0 | 4.0  | 1.0 | 2.0 | .0  |
| 400.0 | 52.0 | 26.0 | 9.0  | 5.0  | 3.0 | 1.0 | .0  |
| 354.0 | 50.0 | 20.0 | 11.0 | 7.0  | 2.0 | .0  | .0  |
| 418.0 | 73.0 | 22.0 | 10.0 | 6.0  | .0  | 1.0 | 1.0 |
| 390.0 | 71.0 | 23.0 | 10.0 | 4.0  | 6.0 | 2.0 | 2.0 |
| 407.0 | 70.0 | 25.0 | 11.0 | 8.0  | 4.0 | 5.0 | .0  |
| 376.0 | 73.0 | 30.0 | 12.0 | 10.0 | 3.0 | 4.0 | 1.0 |
| 408.0 | 74.0 | 24.0 | 13.0 | 5.0  | 5.0 | 3.0 | 1.0 |
| 395.0 | 70.0 | 26.0 | 11.0 | 7.0  | 3.0 | 1.0 | 2.0 |
| 373.0 | 72.0 | 30.0 | 12.0 | 4.0  | 5.0 | 3.0 | 1.0 |
| 339.0 | 70.0 | 25.0 | 10.0 | 9.0  | 3.0 | 2.0 | .0  |
| 377.0 | 71.0 | 26.0 | 11.0 | 3.0  | 1.0 | .0  | 2.0 |
| 376.0 | 72.0 | 27.0 | 11.0 | 5.0  | 2.0 | 1.0 | .0  |
| 445.0 | 79.0 | 27.0 | 9.0  | .0   | 4.0 | .0  | 1.0 |
| 403.0 | 70.0 | 26.0 | 8.0  | 10.0 | 4.0 | 3.0 | 1.0 |
| 402.0 | 73.0 | 27.0 | 11.0 | 3.0  | 1.0 | 2.0 | .0  |
| 342.0 | 75.0 | 19.0 | 11.0 | 6.0  | 4.0 | 1.0 | 2.0 |
| 404.0 | 77.0 | 28.0 | 10.0 | 8.0  | 4.0 | .0  | .0  |
| 380.0 | 71.0 | 29.0 | 11.0 | 3.0  | 3.0 | 3.0 | 2.0 |



0 426.0 54.0 27.0 14.0 5.0 1.0 2.0 1.0  
 LOCATION: 51 NOZZLE PRESSURE: 2.5  
 F SETTING: 1.5 HOOD OPENING: 3.0  
 SAMPLE TIME: 300.

|       |       |      |      |      |      |     |     |
|-------|-------|------|------|------|------|-----|-----|
| 474.0 | 84.0  | 25.0 | 13.0 | 6.0  | 5.0  | 2.0 | .0  |
| 774.0 | 120.0 | 55.0 | 18.0 | 11.0 | 12.0 | 2.0 | 2.0 |
| 458.0 | 68.0  | 25.0 | 14.0 | 8.0  | 5.0  | 1.0 | 1.0 |
| 539.0 | 67.0  | 32.0 | 18.0 | 16.0 | 5.0  | 2.0 | 3.0 |
| 432.0 | 71.0  | 25.0 | 20.0 | 12.0 | 2.0  | 3.0 | 2.0 |
| 484.0 | 72.0  | 32.0 | 10.0 | 8.0  | 4.0  | 2.0 | 1.0 |
| 448.0 | 76.0  | 23.0 | 15.0 | 6.0  | 3.0  | 1.0 | 3.0 |
| 456.0 | 79.0  | 34.0 | 17.0 | 9.0  | 6.0  | .0  | 1.0 |
| 448.0 | 93.0  | 26.0 | 10.0 | 8.0  | 9.0  | 1.0 | 2.0 |
| 514.0 | 83.0  | 28.0 | 12.0 | 9.0  | 6.0  | 3.0 | 2.0 |
| 487.0 | 76.0  | 25.0 | 14.0 | 4.0  | 2.0  | 3.0 | .0  |
| 448.0 | 83.0  | 35.0 | 12.0 | 9.0  | 3.0  | 4.0 | 2.0 |
| 473.0 | 56.0  | 32.0 | 13.0 | 7.0  | 6.0  | 1.0 | 2.0 |
| 493.0 | 74.0  | 26.0 | 8.0  | 3.0  | 5.0  | 1.0 | 1.0 |
| 464.0 | 71.0  | 26.0 | 13.0 | 12.0 | 7.0  | 1.0 | 1.0 |
| 498.0 | 62.0  | 34.0 | 14.0 | 4.0  | 2.0  | 1.0 | 2.0 |
| 427.0 | 75.0  | 29.0 | 15.0 | 8.0  | 3.0  | 1.0 | 1.0 |
| 493.0 | 68.0  | 26.0 | 22.0 | 8.0  | 3.0  | 3.0 | .0  |
| 516.0 | 69.0  | 26.0 | 11.0 | 8.0  | 6.0  | 3.0 | 1.0 |
| 548.0 | 88.0  | 29.0 | 17.0 | 8.0  | .0   | 1.0 | .0  |
| 485.0 | 86.0  | 35.0 | 17.0 | 9.0  | 2.0  | .0  | 3.0 |
| 463.0 | 79.0  | 32.0 | 18.0 | 3.0  | 3.0  | 3.0 | 1.0 |
| 541.0 | 84.0  | 30.0 | 19.0 | 10.0 | 2.0  | 4.0 | 1.0 |
| 419.0 | 79.0  | 23.0 | 13.0 | 9.0  | 3.0  | 2.0 | 1.0 |
| 466.0 | 81.0  | 26.0 | 14.0 | 7.0  | 3.0  | 5.0 | .0  |
| 427.0 | 86.0  | 30.0 | 10.0 | 7.0  | 4.0  | 7.0 | 1.0 |
| 466.0 | 73.0  | 30.0 | 18.0 | 12.0 | 4.0  | 4.0 | 1.0 |
| 494.0 | 76.0  | 30.0 | 13.0 | 9.0  | 3.0  | 1.0 | 1.0 |
| 501.0 | 88.0  | 38.0 | 22.0 | 7.0  | 5.0  | 1.0 | .0  |

0 LOCATION: 78 NOZZLE PRESSURE: 2.5  
 F SETTING: 1.5 HOOD OPENING: 3.0  
 SAMPLE TIME: 300.

|       |       |      |      |      |     |     |     |
|-------|-------|------|------|------|-----|-----|-----|
| 518.0 | 81.0  | 22.0 | 16.0 | 6.0  | 1.0 | 5.0 | .0  |
| 574.0 | 79.0  | 25.0 | 14.0 | 6.0  | 5.0 | 2.0 | .0  |
| 497.0 | 97.0  | 41.0 | 19.0 | 9.0  | 6.0 | 2.0 | .0  |
| 579.0 | 94.0  | 25.0 | 18.0 | 11.0 | 3.0 | 3.0 | .0  |
| 586.0 | 101.0 | 36.0 | 16.0 | 11.0 | 6.0 | 5.0 | 2.0 |
| 553.0 | 83.0  | 29.0 | 13.0 | 6.0  | 4.0 | 2.0 | 1.0 |
| 547.0 | 93.0  | 27.0 | 19.0 | 11.0 | 6.0 | 4.0 | 3.0 |
| 564.0 | 87.0  | 30.0 | 16.0 | 8.0  | 3.0 | 3.0 | 2.0 |
| 523.0 | 93.0  | 35.0 | 21.0 | 11.0 | 6.0 | .0  | 3.0 |
| 587.0 | 93.0  | 27.0 | 15.0 | 6.0  | 3.0 | 3.0 | 1.0 |
| 569.0 | 80.0  | 33.0 | 21.0 | 10.0 | 4.0 | 3.0 | .0  |
| 542.0 | 95.0  | 30.0 | 15.0 | 6.0  | 7.0 | 3.0 | 1.0 |
| 517.0 | 95.0  | 35.0 | 17.0 | 13.0 | 9.0 | 3.0 | 1.0 |
| 569.0 | 102.0 | 20.0 | 20.0 | 9.0  | 3.0 | 3.0 | .0  |
| 599.0 | 99.0  | 27.0 | 26.0 | 6.0  | 9.0 | 8.0 | .0  |
| 609.0 | 99.0  | 43.0 | 14.0 | 10.0 | 5.0 | 4.0 | 2.0 |
| 547.0 | 87.0  | 35.0 | 13.0 | 6.0  | 4.0 | 5.0 | 3.0 |

|       |       |      |      |      |      |     |     |
|-------|-------|------|------|------|------|-----|-----|
| 578.0 | 80.0  | 40.0 | 9.0  | 12.0 | 5.0  | 2.0 | 1.0 |
| 614.0 | 109.0 | 35.0 | 15.0 | 9.0  | 7.0  | 3.0 | .0  |
| 537.0 | 104.0 | 38.0 | 16.0 | 4.0  | 1.0  | 1.0 | 3.0 |
| 575.0 | 91.0  | 36.0 | 17.0 | 13.0 | 9.0  | 2.0 | 1.0 |
| 513.0 | 102.0 | 37.0 | 14.0 | 6.0  | 12.0 | 4.0 | 3.0 |
| 537.0 | 87.0  | 28.0 | 20.0 | 7.0  | 3.0  | 4.0 | 4.0 |
| 571.0 | 102.0 | 33.0 | 17.0 | 9.0  | 5.0  | 5.0 | .0  |
| 619.0 | 120.0 | 27.0 | 19.0 | 7.0  | 6.0  | 3.0 | 4.0 |
| 551.0 | 95.0  | 21.0 | 21.0 | 13.0 | 7.0  | 3.0 | 2.0 |
| 599.0 | 99.0  | 48.0 | 27.0 | 8.0  | 6.0  | 2.0 | 1.0 |

0 LOCATION: 62 NOZZLE PRESSURE: 2.5  
 F SETTING: 1.5 HOOD OPENING: 3.0  
 SAMPLE TIME: 300

|       |      |      |      |      |     |     |     |
|-------|------|------|------|------|-----|-----|-----|
| 446.0 | 96.0 | 31.0 | 12.0 | 5.0  | 8.0 | 3.0 | .0  |
| 444.0 | 87.0 | 23.0 | 15.0 | 3.0  | 2.0 | 2.0 | 1.0 |
| 375.0 | 87.0 | 19.0 | 5.0  | 6.0  | 1.0 | 2.0 | 1.0 |
| 451.0 | 70.0 | 19.0 | 11.0 | 10.0 | 4.0 | 1.0 | .0  |
| 383.0 | 85.0 | 16.0 | 13.0 | 4.0  | 1.0 | 1.0 | .0  |
| 402.0 | 82.0 | 14.0 | 12.0 | 9.0  | 1.0 | 2.0 | 2.0 |
| 403.0 | 72.0 | 24.0 | 15.0 | 7.0  | 1.0 | 1.0 | 1.0 |
| 442.0 | 61.0 | 32.0 | 9.0  | 5.0  | 3.0 | 1.0 | 2.0 |
| 438.0 | 83.0 | 26.0 | 11.0 | 7.0  | 6.0 | .0  | 2.0 |
| 425.0 | 77.0 | 26.0 | 11.0 | 7.0  | 3.0 | 3.0 | .0  |
| 373.0 | 79.0 | 23.0 | 18.0 | 4.0  | 3.0 | 1.0 | 1.0 |
| 410.0 | 66.0 | 24.0 | 10.0 | 9.0  | 1.0 | 8.0 | .0  |
| 345.0 | 86.0 | 22.0 | 10.0 | 5.0  | 3.0 | 1.0 | .0  |
| 384.0 | 71.0 | 19.0 | 17.0 | 8.0  | 2.0 | 2.0 | .0  |
| 408.0 | 77.0 | 33.0 | 20.0 | 5.0  | 2.0 | 5.0 | .0  |
| 363.0 | 80.0 | 29.0 | 12.0 | 3.0  | 2.0 | 1.0 | 1.0 |
| 381.0 | 71.0 | 17.0 | 8.0  | 5.0  | 2.0 | 2.0 | .0  |
| 432.0 | 71.0 | 33.0 | 13.0 | 5.0  | 4.0 | 1.0 | 2.0 |
| 416.0 | 71.0 | 23.0 | 9.0  | 5.0  | 4.0 | .0  | 2.0 |
| 391.0 | 61.0 | 15.0 | 18.0 | 4.0  | 4.0 | 3.0 | 2.0 |
| 404.0 | 61.0 | 21.0 | 17.0 | 12.0 | 4.0 | 3.0 | 1.0 |
| 411.0 | 71.0 | 15.0 | 5.0  | 2.0  | 5.0 | 2.0 | 1.0 |
| 410.0 | 71.0 | 15.0 | 14.0 | 3.0  | 3.0 | 1.0 | 4.0 |
| 411.0 | 71.0 | 15.0 | 17.0 | 6.0  | 3.0 | 2.0 | 2.0 |

NOZZLE PRESSURE: 2.5  
 HOOD OPENING: 3.0

|       |      |      |     |     |     |     |     |
|-------|------|------|-----|-----|-----|-----|-----|
| 170.0 | 71.0 | 20.0 | 3.0 | 1.0 | 1.0 | .0  | .0  |
| 133.0 | 71.0 | 13.0 | 7.0 | 4.0 | .0  | 1.0 | .0  |
| 139.0 | 71.0 | 13.0 | 7.0 | 2.0 | 1.0 | .0  | .0  |
| 141.0 | 71.0 | 13.0 | 7.0 | 2.0 | 2.0 | 1.0 | .0  |
| 137.0 | 71.0 | 13.0 | 7.0 | .0  | 3.0 | 1.0 | 1.0 |
| 111.0 | 71.0 | 13.0 | 7.0 | 7.0 | .0  | .0  | .0  |
| 133.0 | 71.0 | 13.0 | 7.0 | 2.0 | 1.0 | .0  | .0  |
| 129.0 | 71.0 | 13.0 | 7.0 | 3.0 | 1.0 | .0  | .0  |
| 140.0 | 71.0 | 13.0 | 7.0 | 3.0 | 2.0 | .0  | .0  |
| 129.0 | 71.0 | 13.0 | 7.0 | 2.0 | 1.0 | 1.0 | .0  |
| 139.0 | 71.0 | 13.0 | 7.0 | 3.0 | .0  | .0  | .0  |
| 144.0 | 71.0 | 13.0 | 7.0 | 5.0 | .0  | 2.0 | .0  |
| 126.0 | 71.0 | 13.0 | 7.0 | 3.0 | 2.0 | .0  | .0  |

|       |      |      |      |     |     |     |     |
|-------|------|------|------|-----|-----|-----|-----|
| 139.0 | 31.0 | 11.0 | 6.0  | 2.0 | .0  | .0  | .0  |
| 172.0 | 31.0 | 15.0 | 10.0 | 5.0 | .0  | 1.0 | .0  |
| 135.0 | 20.0 | 12.0 | 7.0  | 1.0 | .0  | .0  | .0  |
| 151.0 | 42.0 | 10.0 | 1.0  | 2.0 | 1.0 | .0  | .   |
| 143.0 | 26.0 | 13.0 | 6.0  | 6.0 | 1.0 | .0  | 1.0 |
| 156.0 | 39.0 | 19.0 | 3.0  | 5.0 | .0  | 1.0 | .0  |
| 156.0 | 29.0 | 10.0 | 9.0  | 3.0 | 4.0 | .0  | .0  |
| 140.0 | 30.0 | 3.0  | 6.0  | 2.0 | .0  | .0  | .0  |
| 139.0 | 31.0 | 16.0 | 4.0  | 5.0 | 1.0 | .0  | .0  |
| 133.0 | 17.0 | 20.0 | 5.0  | .0  | 2.0 | 1.0 | .0  |

0 LOCATION: 53 NOZZLE PRESSURE: 2.5  
 F SETTING: 1.5 HOOD OPENING: 3.0  
 SAMPLE TIME: 300.

|       |       |      |      |     |     |     |     |
|-------|-------|------|------|-----|-----|-----|-----|
| 201.0 | 78.0  | 14.0 | 11.0 | 3.0 | 2.0 | 1.0 | .0  |
| 233.0 | 85.0  | 17.0 | 9.0  | 6.0 | 3.0 | 1.0 | .0  |
| 210.0 | 94.0  | 23.0 | 8.0  | 4.0 | 1.0 | .0  | 1.0 |
| 249.0 | 79.0  | 26.0 | 6.0  | 2.0 | 2.0 | 4.0 | 1.0 |
| 222.0 | 102.0 | 17.0 | 6.0  | 4.0 | 1.0 | 2.0 | .0  |
| 197.0 | 104.0 | 18.0 | 9.0  | 3.0 | 3.0 | 1.0 | 1.0 |
| 247.0 | 91.0  | 25.0 | 12.0 | 4.0 | 5.0 | .0  | .0  |
| 204.0 | 84.0  | 17.0 | 7.0  | 3.0 | 3.0 | 1.0 | 1.0 |
| 200.0 | 95.0  | 17.0 | 11.0 | 8.0 | 1.0 | .0  | 1.0 |
| 201.0 | 70.0  | 19.0 | 10.0 | 1.0 | 2.0 | 3.0 | .0  |
| 185.0 | 105.0 | 18.0 | 8.0  | 3.0 | 2.0 | 1.0 | .0  |
| 226.0 | 86.0  | 21.0 | 10.0 | 2.0 | .0  | 1.0 | 1.0 |
| 239.0 | 100.0 | 20.0 | 8.0  | 1.0 | 3.0 | 1.0 | .0  |
| 247.0 | 78.0  | 20.0 | 7.0  | 4.0 | 1.0 | .0  | 1.0 |
| 190.0 | 97.0  | 16.0 | 4.0  | 5.0 | 2.0 | 3.0 | .0  |
| 226.0 | 85.0  | 10.0 | 8.0  | 5.0 | 4.0 | 1.0 | 2.0 |
| 234.0 | 82.0  | 14.0 | 5.0  | 4.0 | 2.0 | .0  | 1.0 |
| 231.0 | 88.0  | 17.0 | 9.0  | 1.0 | 2.0 | .0  | .0  |
| 209.0 | 91.0  | 15.0 | 8.0  | 7.0 | 4.0 | .0  | .0  |
| 242.0 | 84.0  | 13.0 | 11.0 | 6.0 | .0  | 1.0 | .0  |

0 LOCATION: 6 NOZZLE PRESSURE: 2.5  
 F SETTING: 1.5 HOOD OPENING: 3.0  
 SAMPLE TIME: 300.

|       |      |      |      |     |     |     |     |
|-------|------|------|------|-----|-----|-----|-----|
| 272.0 | 62.0 | 24.0 | 7.0  | 7.0 | 2.0 | 1.0 | .0  |
| 266.0 | 61.0 | 14.0 | 7.0  | 1.0 | .0  | 2.0 | .0  |
| 192.0 | 63.0 | 24.0 | 9.0  | 5.0 | 2.0 | 1.0 | 2.0 |
| 268.0 | 46.0 | 21.0 | 5.0  | 8.0 | .0  | 1.0 | 2.0 |
| 317.0 | 70.0 | 18.0 | 6.0  | 2.0 | 2.0 | 1.0 | 1.0 |
| 249.0 | 73.0 | 16.0 | 7.0  | 7.0 | 3.0 | .0  | 1.0 |
| 363.0 | 67.0 | 20.0 | 8.0  | 8.0 | 3.0 | 2.0 | 2.0 |
| 222.0 | 69.0 | 23.0 | 4.0  | 1.0 | 1.0 | 1.0 | 1.0 |
| 254.0 | 68.0 | 18.0 | 4.0  | 4.0 | 3.0 | 2.0 | 1.0 |
| 266.0 | 63.0 | 20.0 | 7.0  | 6.0 | .0  | 2.0 | 1.0 |
| 242.0 | 76.0 | 25.0 | 12.0 | 4.0 | 4.0 | 2.0 | .0  |
| 246.0 | 63.0 | 13.0 | 6.0  | 7.0 | 1.0 | 1.0 | .0  |
| 249.0 | 61.0 | 23.0 | 6.0  | 7.0 | 1.0 | 1.0 | 1.0 |
| 292.0 | 56.0 | 24.0 | 4.0  | 6.0 | 2.0 | 2.0 | .0  |
| 254.0 | 52.0 | 21.0 | 8.0  | 8.0 | .0  | 1.0 | 1.0 |
| 286.0 | 60.0 | 22.0 | 6.0  | 5.0 | 3.0 | 1.0 | .0  |
| 210.0 | 48.0 | 19.0 | 12.0 | 1.0 | 1.0 | 4.0 | 1.0 |

|       |      |      |      |     |     |     |     |
|-------|------|------|------|-----|-----|-----|-----|
| 258.0 | 47.0 | 15.0 | 16.0 | 3.0 | 1.0 | 1.0 | 1.0 |
| 279.0 | 51.0 | 16.0 | 8.0  | 4.0 | 2.0 | .0  | .0  |
| 279.0 | 74.0 | 11.0 | 7.0  | 2.0 | 1.0 | 3.0 | 2.0 |
| 298.0 | 69.0 | 17.0 | 5.0  | 8.0 | 5.0 | 5.0 | .0  |

0 LOCATION: 32 NOZZLE PRESSURE: 2.5  
 F SETTING: 1.5 HOOD OPENING: 3.0  
 SAMPLE TIME: 300.

|       |      |      |      |      |     |     |     |
|-------|------|------|------|------|-----|-----|-----|
| 128.0 | 58.0 | 16.0 | 4.0  | 1.0  | 1.0 | 1.0 | 1.0 |
| 201.0 | 58.0 | 18.0 | 7.0  | 2.0  | 3.0 | 1.0 | .0  |
| 112.0 | 32.0 | 21.0 | 8.0  | .0   | .0  | 2.0 | 1.0 |
| 134.0 | 41.0 | 14.0 | 5.0  | 1.0  | 3.0 | 1.0 | .0  |
| 156.0 | 51.0 | 13.0 | 10.0 | 6.0  | 3.0 | 2.0 | .0  |
| 177.0 | 47.0 | 15.0 | 5.0  | 1.0  | 2.0 | 3.0 | .0  |
| 174.0 | 38.0 | 24.0 | 10.0 | 1.0  | .0  | .0  | .0  |
| 166.0 | 44.0 | 13.0 | 13.0 | 2.0  | .0  | 1.0 | .0  |
| 189.0 | 40.0 | 15.0 | 7.0  | 1.0  | 2.0 | .0  | .0  |
| 145.0 | 41.0 | 22.0 | 8.0  | 3.0  | 4.0 | .0  | 1.0 |
| 127.0 | 42.0 | 19.0 | 10.0 | 4.0  | .0  | .0  | 1.0 |
| 142.0 | 52.0 | 25.0 | 8.0  | 6.0  | 2.0 | 1.0 | 1.0 |
| 176.0 | 55.0 | 21.0 | 5.0  | 3.0  | 2.0 | .0  | .0  |
| 152.0 | 41.0 | 19.0 | 9.0  | 10.0 | 1.0 | 2.0 | .0  |
| 150.0 | 37.0 | 19.0 | 6.0  | 4.0  | 1.0 | .0  | 2.0 |
| 158.0 | 50.0 | 23.0 | 10.0 | 5.0  | 2.0 | .0  | 2.0 |
| 173.0 | 44.0 | 16.0 | 9.0  | 1.0  | 2.0 | 1.0 | .0  |
| 143.0 | 45.0 | 20.0 | 8.0  | 1.0  | 1.0 | 1.0 | 1.0 |
| 131.0 | 32.0 | 17.0 | 11.0 | 6.0  | .0  | .0  | .0  |
| 134.0 | 38.0 | 16.0 | 10.0 | 1.0  | 2.0 | .0  | .0  |
| 140.0 | 45.0 | 17.0 | 4.0  | 5.0  | 1.0 | .0  | .0  |

0 LOCATION: 35 NOZZLE PRESSURE: 2.5  
 F SETTING: 1.5 HOOD OPENING: 3.0  
 SAMPLE TIME: 300.

|       |      |      |      |     |     |     |     |
|-------|------|------|------|-----|-----|-----|-----|
| 179.0 | 53.0 | 23.0 | 12.0 | 3.0 | 4.0 | 3.0 | .0  |
| 148.0 | 47.0 | 19.0 | 10.0 | 4.0 | 1.0 | .0  | .0  |
| 180.0 | 47.0 | 26.0 | 6.0  | 7.0 | 3.0 | .0  | .0  |
| 161.0 | 47.0 | 17.0 | 10.0 | 4.0 | 2.0 | 1.0 | .0  |
| 227.0 | 53.0 | 14.0 | 9.0  | 2.0 | 1.0 | 2.0 | .0  |
| 209.0 | 51.0 | 22.0 | 10.0 | 9.0 | 1.0 | .0  | .0  |
| 153.0 | 37.0 | 17.0 | 11.0 | 9.0 | 2.0 | 1.0 | .0  |
| 169.0 | 47.0 | 15.0 | 10.0 | 3.0 | 4.0 | .0  | .0  |
| 188.0 | 44.0 | 24.0 | 11.0 | 6.0 | 4.0 | .0  | 1.0 |
| 135.0 | 51.0 | 25.0 | 6.0  | 3.0 | 1.0 | .0  | 1.0 |
| 172.0 | 53.0 | 17.0 | 11.0 | 4.0 | 2.0 | 1.0 | 1.0 |
| 175.0 | 52.0 | 20.0 | 10.0 | 2.0 | 4.0 | 1.0 | 1.0 |
| 196.0 | 47.0 | 22.0 | 11.0 | 7.0 | 1.0 | 1.0 | .0  |
| 149.0 | 45.0 | 19.0 | 12.0 | 5.0 | 1.0 | 2.0 | 1.0 |
| 186.0 | 48.0 | 20.0 | 16.0 | 5.0 | 1.0 | 3.0 | 1.0 |
| 211.0 | 65.0 | 19.0 | 11.0 | 2.0 | 3.0 | .0  | .0  |
| 199.0 | 47.0 | 21.0 | 9.0  | 2.0 | 3.0 | 3.0 | .0  |

0 LOCATION: 26 NOZZLE PRESSURE: 2.5  
 F SETTING: 1.5 HOOD OPENING: 3.0  
 SAMPLE TIME: 300.

|       |      |      |      |      |     |     |     |
|-------|------|------|------|------|-----|-----|-----|
| 257.0 | 53.0 | 27.0 | 17.0 | 3.0  | 1.0 | 2.0 | .0  |
| 263.0 | 71.0 | 25.0 | 12.0 | 2.0  | 4.0 | .0  | .0  |
| 311.0 | 62.0 | 29.0 | 14.0 | 1.0  | 1.0 | 1.0 | .0  |
| 269.0 | 52.0 | 24.0 | 14.0 | 3.0  | 1.0 | 2.0 | .0  |
| 304.0 | 65.0 | 24.0 | 10.0 | 8.0  | 1.0 | .0  | .0  |
| 245.0 | 57.0 | 20.0 | 10.0 | 11.0 | .0  | 2.0 | .0  |
| 245.0 | 51.0 | 25.0 | 6.0  | 2.0  | 4.0 | .0  | 1.0 |
| 267.0 | 67.0 | 33.0 | 13.0 | 4.0  | 1.0 | 2.0 | .0  |
| 293.0 | 57.0 | 31.0 | 20.0 | 6.0  | .0  | 1.0 | 2.0 |
| 277.0 | 87.0 | 27.0 | 12.0 | 9.0  | 1.0 | 3.0 | 1.0 |
| 267.0 | 64.0 | 35.0 | 14.0 | 4.0  | 2.0 | .0  | .0  |
| 256.0 | 68.0 | 31.0 | 7.0  | 3.0  | 2.0 | .0  | .0  |
| 276.0 | 59.0 | 29.0 | 12.0 | 10.0 | 3.0 | .0  | .0  |
| 278.0 | 76.0 | 26.0 | 7.0  | 7.0  | 2.0 | .0  | .0  |
| 274.0 | 71.0 | 21.0 | 17.0 | 7.0  | 1.0 | .0  | .0  |
| 290.0 | 63.0 | 32.0 | 13.0 | 8.0  | 4.0 | 2.0 | .0  |
| 252.0 | 56.0 | 22.0 | 13.0 | 4.0  | .0  | .0  | .0  |
| 294.0 | 70.0 | 29.0 | 10.0 | 9.0  | 1.0 | 1.0 | 3.0 |
| 278.0 | 60.0 | 27.0 | 10.0 | 4.0  | 1.0 | 2.0 | 2.0 |
| 279.0 | 86.0 | 27.0 | 12.0 | 4.0  | 2.0 | 1.0 | 1.0 |
| 249.0 | 64.0 | 19.0 | 8.0  | 6.0  | 1.0 | 2.0 | 1.0 |
| 263.0 | 64.0 | 23.0 | 13.0 | 3.0  | 2.0 | 1.0 | 1.0 |
| 281.0 | 52.0 | 22.0 | 13.0 | 7.0  | 3.0 | 2.0 | 1.0 |
| 287.0 | 76.0 | 23.0 | 12.0 | 5.0  | 1.0 | .0  | .0  |
| 250.0 | 76.0 | 26.0 | 11.0 | 6.0  | 1.0 | 4.0 | .0  |

0 LOCATION: 40 NOZZLE PRESSURE: 2.5  
 F SETTING: 1.5 HOOD OPENING: 3.0  
 SAMPLE TIME: 300.

|       |      |      |      |     |     |     |     |
|-------|------|------|------|-----|-----|-----|-----|
| 390.0 | 56.0 | 15.0 | 6.0  | 2.0 | 3.0 | 1.0 | .0  |
| 368.0 | 48.0 | 17.0 | 5.0  | 1.0 | 1.0 | .0  | .0  |
| 373.0 | 68.0 | 22.0 | 6.0  | 2.0 | 1.0 | 2.0 | .0  |
| 345.0 | 66.0 | 17.0 | 8.0  | 5.0 | .0  | .0  | .0  |
| 370.0 | 59.0 | 20.0 | 9.0  | 2.0 | 3.0 | .0  | .0  |
| 391.0 | 58.0 | 20.0 | 12.0 | 2.0 | 2.0 | 1.0 | 1.0 |
| 357.0 | 72.0 | 24.0 | 9.0  | .0  | 3.0 | 2.0 | 1.0 |
| 381.0 | 81.0 | 25.0 | 6.0  | 4.0 | 2.0 | 1.0 | .0  |
| 366.0 | 69.0 | 19.0 | 6.0  | 2.0 | .0  | .0  | 1.0 |
| 403.0 | 64.0 | 24.0 | 5.0  | 2.0 | 1.0 | 2.0 | .0  |
| 400.0 | 71.0 | 22.0 | 4.0  | 3.0 | 1.0 | .0  | .0  |
| 429.0 | 82.0 | 24.0 | 6.0  | 3.0 | 1.0 | 3.0 | .0  |
| 392.0 | 66.0 | 26.0 | 10.0 | 4.0 | .0  | .0  | .0  |
| 392.0 | 68.0 | 28.0 | 9.0  | 3.0 | 2.0 | 4.0 | 1.0 |
| 374.0 | 98.0 | 20.0 | 10.0 | 2.0 | 5.0 | 2.0 | .0  |
| 331.0 | 85.0 | 23.0 | 9.0  | 3.0 | 2.0 | .0  | 1.0 |
| 409.0 | 92.0 | 26.0 | 12.0 | 3.0 | 3.0 | .0  | 2.0 |
| 371.0 | 73.0 | 23.0 | 16.0 | 2.0 | 3.0 | .0  | 1.0 |
| 385.0 | 73.0 | 27.0 | 5.0  | 3.0 | 1.0 | .0  | .0  |
| 380.0 | 72.0 | 26.0 | 5.0  | 4.0 | 1.0 | 1.0 | .0  |
| 393.0 | 69.0 | 14.0 | 11.0 | 4.0 | .0  | .0  | .0  |

0 LOCATION: 37 NOZZLE PRESSURE: 2.5  
 F SETTING: 1.5 HOOD OPENING: 3.0  
 SAMPLE TIME: 300.

|       |      |      |      |     |     |     |    |
|-------|------|------|------|-----|-----|-----|----|
| 440.0 | 72.0 | 26.0 | 16.0 | 4.0 | 3.0 | 1.0 | .0 |
|-------|------|------|------|-----|-----|-----|----|

|       |      |      |      |     |     |     |     |
|-------|------|------|------|-----|-----|-----|-----|
| 418.0 | 87.0 | 34.0 | 18.0 | 4.0 | 5.0 | 1.0 | 1.0 |
| 443.0 | 72.0 | 36.0 | 14.0 | 8.0 | 4.0 | .0  | 1.0 |
| 479.0 | 57.0 | 33.0 | 10.0 | 3.0 | 1.0 | .0  | 1.0 |
| 505.0 | 75.0 | 23.0 | 11.0 | 7.0 | 4.0 | 2.0 | .0  |
| 460.0 | 75.0 | 19.0 | 12.0 | 6.0 | 1.0 | 3.0 | .0  |
| 446.0 | 62.0 | 29.0 | 15.0 | 5.0 | 5.0 | 2.0 | .0  |
| 426.0 | 74.0 | 22.0 | 14.0 | 3.0 | 1.0 | .0  | .0  |
| 420.0 | 68.0 | 23.0 | 20.0 | 7.0 | 2.0 | 3.0 | 3.0 |
| 455.0 | 72.0 | 33.0 | 15.0 | 3.0 | .0  | 2.0 | 1.0 |
| 438.0 | 79.0 | 32.0 | 15.0 | 2.0 | 3.0 | 2.0 | 1.0 |
| 467.0 | 84.0 | 39.0 | 16.0 | 6.0 | 1.0 | .0  | 1.0 |
| 459.0 | 85.0 | 25.0 | 15.0 | 5.0 | 4.0 | .0  | 2.0 |
| 418.0 | 75.0 | 32.0 | 5.0  | 2.0 | 3.0 | 1.0 | 1.0 |
| 452.0 | 81.0 | 25.0 | 15.0 | 4.0 | 3.0 | 1.0 | 1.0 |
| 474.0 | 66.0 | 39.0 | 13.0 | 7.0 | 2.0 | 1.0 | .0  |
| 486.0 | 81.0 | 32.0 | 15.0 | 4.0 | 2.0 | 4.0 | 2.0 |
| 504.0 | 76.0 | 25.0 | 11.0 | 7.0 | 2.0 | 2.0 | .0  |
| 423.0 | 77.0 | 28.0 | 19.0 | 4.0 | 1.0 | 1.0 | 2.0 |
| 395.0 | 77.0 | 32.0 | 12.0 | 6.0 | 1.0 | 1.0 | 1.0 |
| 468.0 | 72.0 | 31.0 | 13.0 | 5.0 | 4.0 | 1.0 | .0  |
| 467.0 | 93.0 | 19.0 | 11.0 | 1.0 | 1.0 | 3.0 | 1.0 |
| 450.0 | 82.0 | 29.0 | 15.0 | 7.0 | 3.0 | .0  | 1.0 |
| 423.0 | 54.0 | 15.0 | 6.0  | 2.0 | 2.0 | .0  | .0  |
| 457.0 | 68.0 | 34.0 | 13.0 | 8.0 | .0  | .0  | .0  |

0 LOCATION: 15 NOZZLE PRESSURE: 2.5  
 F. SETTINGS: 1.5 HOOD OPENING: 3.0  
 SAMPLE TIME: 300.

|       |       |      |      |      |     |     |     |
|-------|-------|------|------|------|-----|-----|-----|
| 563.0 | 95.0  | 33.0 | 12.0 | 10.0 | 6.0 | 3.0 | 1.0 |
| 567.0 | 92.0  | 39.0 | 17.0 | 5.0  | 1.0 | 1.0 | .0  |
| 581.0 | 94.0  | 44.0 | 22.0 | 11.0 | .0  | 1.0 | .0  |
| 548.0 | 75.0  | 40.0 | 16.0 | 12.0 | 3.0 | 1.0 | 1.0 |
| 513.0 | 83.0  | 29.0 | 17.0 | 9.0  | 6.0 | 1.0 | .0  |
| 512.0 | 84.0  | 32.0 | 12.0 | 11.0 | 6.0 | 3.0 | .0  |
| 511.0 | 78.0  | 31.0 | 22.0 | 3.0  | 5.0 | 1.0 | 1.0 |
| 558.0 | 78.0  | 34.0 | 7.0  | 6.0  | 1.0 | 1.0 | 1.0 |
| 543.0 | 91.0  | 33.0 | 16.0 | 7.0  | 2.0 | 2.0 | 1.0 |
| 569.0 | 108.0 | 37.0 | 13.0 | 7.0  | 5.0 | 1.0 | .0  |
| 565.0 | 105.0 | 30.0 | 10.0 | 8.0  | 1.0 | .0  | .0  |
| 560.0 | 87.0  | 32.0 | 27.0 | 10.0 | 1.0 | .0  | .0  |
| 615.0 | 107.0 | 35.0 | 7.0  | 7.0  | 8.0 | 1.0 | 1.0 |
| 527.0 | 77.0  | 22.0 | 11.0 | 4.0  | 2.0 | 1.0 | 2.0 |
| 565.0 | 91.0  | 37.0 | 13.0 | 10.0 | 3.0 | 5.0 | .0  |
| 570.0 | 80.0  | 38.0 | 13.0 | 8.0  | 2.0 | 2.0 | .0  |
| 512.0 | 95.0  | 34.0 | 13.0 | 6.0  | 6.0 | 3.0 | .0  |
| 533.0 | 83.0  | 30.0 | 7.0  | 12.0 | 3.0 | 3.0 | 2.0 |
| 542.0 | 76.0  | 38.0 | 14.0 | 5.0  | 2.0 | 2.0 | 1.0 |
| 539.0 | 84.0  | 31.0 | 17.0 | 8.0  | 2.0 | 3.0 | 1.0 |
| 513.0 | 80.0  | 31.0 | 11.0 | 4.0  | 3.0 | 1.0 | 4.0 |
| 517.0 | 90.0  | 37.0 | 19.0 | 9.0  | 1.0 | 2.0 | .0  |
| 558.0 | 100.0 | 30.0 | 12.0 | 9.0  | 4.0 | 2.0 | 1.0 |
| 578.0 | 84.0  | 43.0 | 8.0  | 10.0 | 1.0 | 2.0 | 1.0 |
| 560.0 | 95.0  | 44.0 | 12.0 | 11.0 | 3.0 | 1.0 | .0  |
| 472.0 | 94.0  | 31.0 | 16.0 | 3.0  | 4.0 | 2.0 | 3.0 |

0 LOCATION: 15 NOZZLE PRESSURE: 2.5  
 F. SETTINGS: 1.5 HOOD OPENING: 3.0

SAMPLE TIME: 300.

|       |      |      |      |     |     |     |     |
|-------|------|------|------|-----|-----|-----|-----|
| 441.0 | 55.0 | 28.0 | 11.0 | 6.0 | 3.0 | 1.0 | .0  |
| 427.0 | 90.0 | 17.0 | 15.0 | 8.0 | 1.0 | 1.0 | 2.0 |
| 447.0 | 93.0 | 25.0 | 13.0 | 5.0 | 4.0 | .0  | 1.0 |
| 435.0 | 81.0 | 26.0 | 11.0 | 3.0 | 3.0 | 1.0 | 1.0 |
| 476.0 | 69.0 | 28.0 | 15.0 | 2.0 | 4.0 | 2.0 | 1.0 |
| 474.0 | 85.0 | 28.0 | 8.0  | 5.0 | 5.0 | .0  | 1.0 |
| 460.0 | 72.0 | 26.0 | 8.0  | 5.0 | 2.0 | .0  | 1.0 |
| 466.0 | 78.0 | 22.0 | 12.0 | 4.0 | 6.0 | 2.0 | 1.0 |
| 488.0 | 64.0 | 24.0 | 4.0  | 3.0 | 1.0 | 4.0 | .0  |
| 458.0 | 73.0 | 28.0 | 17.0 | 8.0 | 2.0 | 2.0 | .0  |
| 419.0 | 60.0 | 18.0 | 12.0 | 5.0 | 1.0 | 1.0 | 1.0 |
| 373.0 | 76.0 | 19.0 | 12.0 | 6.0 | 3.0 | 2.0 | .0  |
| 419.0 | 63.0 | 25.0 | 10.0 | 4.0 | 1.0 | 2.0 | .0  |
| 471.0 | 86.0 | 22.0 | 13.0 | 5.0 | 3.0 | 1.0 | .0  |
| 375.0 | 80.0 | 34.0 | 8.0  | 7.0 | .0  | .0  | 2.0 |
| 460.0 | 63.0 | 21.0 | 10.0 | 3.0 | .0  | .0  | 1.0 |
| 425.0 | 67.0 | 25.0 | 10.0 | 2.0 | 3.0 | 2.0 | 3.0 |
| 421.0 | 67.0 | 25.0 | 15.0 | 9.0 | .0  | 2.0 | 1.0 |
| 436.0 | 72.0 | 21.0 | 10.0 | 6.0 | 4.0 | 3.0 | 1.0 |
| 448.0 | 74.0 | 23.0 | 10.0 | 7.0 | 1.0 | 2.0 | 1.0 |
| 367.0 | 70.0 | 24.0 | 6.0  | 5.0 | 3.0 | 1.0 | .0  |
| 413.0 | 83.0 | 23.0 | 17.0 | 4.0 | 3.0 | .0  | .0  |
| 451.0 | 75.0 | 35.0 | 15.0 | 4.0 | 1.0 | 1.0 | .0  |
| 428.0 | 72.0 | 22.0 | 9.0  | 4.0 | 1.0 | 4.0 | 1.0 |
| 456.0 | 69.0 | 25.0 | 12.0 | 7.0 | 3.0 | 2.0 | 1.0 |
| 443.0 | 69.0 | 19.0 | 11.0 | 7.0 | 2.0 | 3.0 | .0  |
| 430.0 | 63.0 | 17.0 | 10.0 | 2.0 | 4.0 | 1.0 | 2.0 |
| 447.0 | 71.0 | 28.0 | 11.0 | 6.0 | 1.0 | .0  | .0  |
| 425.0 | 66.0 | 20.0 | 9.0  | 4.0 | 2.0 | .0  | .0  |

0 LOCATION: 46 NOZZLE PRESSURE: 2.5  
 F SETTING: 1.5 HOOD OPENING: 3.0  
 SAMPLE TIME: 300.

|       |      |      |      |     |     |     |     |
|-------|------|------|------|-----|-----|-----|-----|
| 378.0 | 45.0 | 19.0 | 9.0  | 6.0 | .0  | 1.0 | .0  |
| 344.0 | 46.0 | 12.0 | 9.0  | 3.0 | 2.0 | .0  | .0  |
| 397.0 | 50.0 | 15.0 | 7.0  | .0  | 1.0 | .0  | .0  |
| 402.0 | 54.0 | 28.0 | .0   | 3.0 | .0  | 3.0 | .0  |
| 329.0 | 45.0 | 17.0 | 9.0  | 4.0 | 1.0 | .0  | .0  |
| 319.0 | 45.0 | 16.0 | 6.0  | 3.0 | 1.0 | .0  | .0  |
| 338.0 | 53.0 | 17.0 | 8.0  | 3.0 | .0  | 1.0 | .0  |
| 377.0 | 54.0 | 31.0 | 6.0  | 2.0 | .0  | .0  | .0  |
| 377.0 | 65.0 | 25.0 | 7.0  | 7.0 | 1.0 | .0  | 2.0 |
| 402.0 | 54.0 | 26.0 | 6.0  | 3.0 | 2.0 | .0  | .0  |
| 367.0 | 52.0 | 20.0 | 5.0  | 3.0 | 1.0 | .0  | .0  |
| 325.0 | 54.0 | 16.0 | 4.0  | 3.0 | .0  | 1.0 | .0  |
| 369.0 | 41.0 | 18.0 | 8.0  | 3.0 | .0  | .0  | .0  |
| 289.0 | 44.0 | 23.0 | 8.0  | 6.0 | 2.0 | .0  | .0  |
| 315.0 | 54.0 | 17.0 | 10.0 | 7.0 | .0  | 1.0 | .0  |
| 328.0 | 52.0 | 27.0 | 7.0  | 4.0 | 2.0 | .0  | .0  |
| 329.0 | 43.0 | 20.0 | 7.0  | 4.0 | .0  | 1.0 | .0  |
| 328.0 | 46.0 | 17.0 | 6.0  | .0  | 2.0 | .0  | .0  |
| 383.0 | 57.0 | 26.0 | 4.0  | 4.0 | 1.0 | 1.0 | .0  |
| 339.0 | 60.0 | 14.0 | 4.0  | 2.0 | 2.0 | .0  | .0  |

|       |      |      |      |     |     |     |     |
|-------|------|------|------|-----|-----|-----|-----|
| 354.0 | 54.0 | 25.0 | 8.0  | 5.0 | .0  | .0  | .0  |
| 335.0 | 64.0 | 22.0 | 9.0  | 4.0 | 1.0 | .0  | .0  |
| 313.0 | 66.0 | 19.0 | 8.0  | 4.0 | 2.0 | .0  | .0  |
| 372.0 | 53.0 | 23.0 | 11.0 | 3.0 | 2.0 | 1.0 | .0  |
| 366.0 | 44.0 | 20.0 | 6.0  | 2.0 | 1.0 | 1.0 | .0  |
| 325.0 | 70.0 | 19.0 | 8.0  | 4.0 | .0  | .0  | 1.0 |

0 LOCATION: 25 NOZZLE PRESSURE: 2.5  
 F SETTING: 1.5 HOOD OPENING: 3.0  
 SAMPLE TIME: 300.

|       |      |      |     |     |     |     |     |
|-------|------|------|-----|-----|-----|-----|-----|
| 154.0 | 27.0 | 10.0 | 2.0 | 1.0 | .0  | .0  | .0  |
| 134.0 | 34.0 | 7.0  | 2.0 | 1.0 | 2.0 | .0  | .0  |
| 135.0 | 22.0 | 5.0  | 5.0 | 1.0 | .0  | .0  | .0  |
| 127.0 | 25.0 | 8.0  | 3.0 | 2.0 | 1.0 | 2.0 | .0  |
| 191.0 | 32.0 | 14.0 | 3.0 | 3.0 | 1.0 | .0  | .0  |
| 152.0 | 31.0 | 11.0 | 2.0 | 2.0 | 1.0 | .0  | .0  |
| 133.0 | 27.0 | 12.0 | 3.0 | 2.0 | 1.0 | .0  | .0  |
| 166.0 | 31.0 | 9.0  | 5.0 | 1.0 | 1.0 | .0  | 1.0 |
| 144.0 | 22.0 | 10.0 | 4.0 | 1.0 | 2.0 | 2.0 | .0  |
| 159.0 | 30.0 | 10.0 | 2.0 | .0  | .0  | .0  | .0  |
| 142.0 | 39.0 | 13.0 | 6.0 | 1.0 | 1.0 | .0  | .0  |
| 152.0 | 15.0 | 7.0  | 4.0 | 2.0 | 1.0 | .0  | 1.0 |
| 161.0 | 23.0 | 11.0 | 3.0 | 1.0 | .0  | .0  | .0  |
| 156.0 | 23.0 | 12.0 | 4.0 | 1.0 | .0  | .0  | .0  |
| 140.0 | 24.0 | 7.0  | 4.0 | 2.0 | .0  | .0  | 1.0 |
| 124.0 | 22.0 | 5.0  | 6.0 | .0  | 1.0 | .0  | .0  |
| 166.0 | 32.0 | 16.0 | 5.0 | 3.0 | 1.0 | .0  | .0  |
| 144.0 | 27.0 | 10.0 | .0  | 1.0 | .0  | .0  | .0  |
| 135.0 | 22.0 | 11.0 | 4.0 | 4.0 | .0  | .0  | .0  |
| 154.0 | 21.0 | 12.0 | 8.0 | .0  | .0  | 1.0 | .0  |
| 127.0 | 27.0 | 8.0  | 1.0 | 1.0 | 1.0 | .0  | .0  |
| 163.0 | 25.0 | 6.0  | 5.0 | .0  | .0  | .0  | .0  |
| 160.0 | 26.0 | 10.0 | 5.0 | .0  | 1.0 | .0  | .0  |
| 157.0 | 24.0 | 14.0 | 5.0 | .0  | .0  | .0  | .0  |
| 118.0 | 29.0 | 8.0  | 6.0 | .0  | .0  | .0  | .0  |

0 LOCATION: 52 NOZZLE PRESSURE: 2.5  
 F SETTING: 1.5 HOOD OPENING: 3.0  
 SAMPLE TIME: 300.

|       |      |      |     |     |     |     |     |
|-------|------|------|-----|-----|-----|-----|-----|
| 184.0 | 20.0 | 5.0  | 2.0 | 1.0 | 1.0 | 1.0 | .0  |
| 174.0 | 20.0 | 10.0 | 3.0 | .0  | 1.0 | 1.0 | .0  |
| 168.0 | 31.0 | 7.0  | 1.0 | .0  | 1.0 | 2.0 | .0  |
| 157.0 | 35.0 | 10.0 | 4.0 | 2.0 | 1.0 | 1.0 | 1.0 |
| 192.0 | 33.0 | 9.0  | 3.0 | 1.0 | 1.0 | 1.0 | .0  |
| 189.0 | 25.0 | 10.0 | 4.0 | .0  | .0  | .0  | 1.0 |
| 160.0 | 23.0 | 10.0 | 2.0 | 2.0 | 1.0 | .0  | .0  |
| 156.0 | 36.0 | 9.0  | 4.0 | .0  | .0  | .0  | 1.0 |
| 163.0 | 23.0 | 10.0 | 3.0 | 1.0 | .0  | .0  | .0  |
| 171.0 | 34.0 | 10.0 | 2.0 | 1.0 | 1.0 | 2.0 | .0  |
| 158.0 | 27.0 | 8.0  | 1.0 | .0  | 1.0 | .0  | 1.0 |
| 207.0 | 27.0 | 4.0  | 2.0 | .0  | .0  | 1.0 | .0  |
| 194.0 | 33.0 | 10.0 | 3.0 | .0  | 1.0 | .0  | .0  |
| 172.0 | 36.0 | 4.0  | 5.0 | 2.0 | .0  | 3.0 | .0  |
| 174.0 | 36.0 | 10.0 | 2.0 | 3.0 | 2.0 | .0  | .0  |
| 205.0 | 27.0 | 5.0  | .0  | 1.0 | .0  | 1.0 | .0  |



|       |      |      |     |     |     |     |     |
|-------|------|------|-----|-----|-----|-----|-----|
| 189.0 | 30.0 | 6.0  | 2.0 | .0  | 1.0 | .0  | .0  |
| 191.0 | 33.0 | 6.0  | 1.0 | 1.0 | .0  | .0  | .0  |
| 174.0 | 35.0 | 12.0 | 4.0 | 1.0 | .0  | .0  | .0  |
| 173.0 | 36.0 | 8.0  | 5.0 | .0  | 1.0 | .0  | 1.0 |
| 164.0 | 26.0 | 13.0 | 1.0 | 2.0 | .0  | .0  | .0  |
| 133.0 | 30.0 | 17.0 | 5.0 | 4.0 | .0  | 1.0 | .0  |
| 160.0 | 30.0 | 7.0  | 3.0 | 1.0 | 1.0 | .0  | .0  |
| 166.0 | 19.0 | 4.0  | 1.0 | 2.0 | .0  | .0  | .0  |
| 160.0 | 28.0 | 8.0  | 5.0 | .0  | 1.0 | 1.0 | .0  |

0 LOCATION: 74 NOZZLE PRESSURE: 2.5  
 F SETTING: 1.5 HOOD OPENING: 3.0  
 SAMPLE TIME: 300.

|       |       |      |      |      |      |     |     |
|-------|-------|------|------|------|------|-----|-----|
| 849.0 | 147.0 | 45.0 | 31.0 | 8.0  | 8.0  | 7.0 | 3.0 |
| 869.0 | 172.0 | 49.0 | 26.0 | 11.0 | 7.0  | 4.0 | 2.0 |
| 919.0 | 155.0 | 42.0 | 23.0 | 9.0  | 4.0  | 4.0 | 5.0 |
| 952.0 | 179.0 | 56.0 | 22.0 | 12.0 | 4.0  | 7.0 | .0  |
| 839.0 | 171.0 | 55.0 | 22.0 | 18.0 | 5.0  | 7.0 | 1.0 |
| 869.0 | 163.0 | 57.0 | 23.0 | 15.0 | 7.0  | 1.0 | 2.0 |
| 938.0 | 137.0 | 48.0 | 26.0 | 14.0 | 8.0  | 1.0 | 5.0 |
| 890.0 | 164.0 | 41.0 | 17.0 | 6.0  | 6.0  | 4.0 | 2.0 |
| 855.0 | 169.0 | 53.0 | 22.0 | 9.0  | 5.0  | 2.0 | .0  |
| 887.0 | 160.0 | 62.0 | 26.0 | 16.0 | 13.0 | 1.0 | 2.0 |
| 859.0 | 157.0 | 53.0 | 21.0 | 8.0  | 6.0  | 4.0 | 1.0 |
| 891.0 | 133.0 | 45.0 | 14.0 | 7.0  | 13.0 | 3.0 | 5.0 |
| 863.0 | 158.0 | 46.0 | 22.0 | 8.0  | 5.0  | 5.0 | 3.0 |
| 865.0 | 151.0 | 39.0 | 21.0 | 10.0 | 5.0  | 3.0 | 2.0 |
| 847.0 | 154.0 | 52.0 | 28.0 | 9.0  | 10.0 | 3.0 | 2.0 |
| 881.0 | 152.0 | 33.0 | 29.0 | 15.0 | 5.0  | 2.0 | 1.0 |
| 835.0 | 155.0 | 54.0 | 18.0 | 16.0 | 3.0  | 7.0 | .0  |
| 941.0 | 167.0 | 63.0 | 18.0 | 10.0 | 4.0  | 7.0 | 1.0 |
| 849.0 | 152.0 | 60.0 | 24.0 | 17.0 | 4.0  | 3.0 | 3.0 |
| 826.0 | 139.0 | 44.0 | 18.0 | 9.0  | 5.0  | 5.0 | 2.0 |
| 887.0 | 134.0 | 50.0 | 13.0 | 10.0 | 7.0  | 2.0 | 2.0 |
| 830.0 | 171.0 | 50.0 | 17.0 | 9.0  | 8.0  | 2.0 | 3.0 |
| 842.0 | 125.0 | 42.0 | 11.0 | 11.0 | 3.0  | 3.0 | 1.0 |
| 925.0 | 147.0 | 51.0 | 27.0 | 15.0 | 5.0  | 2.0 | .0  |
| 959.0 | 190.0 | 53.0 | 26.0 | 12.0 | 4.0  | 5.0 | .0  |
| 881.0 | 167.0 | 51.0 | 17.0 | 6.0  | 10.0 | 3.0 | 1.0 |
| 837.0 | 174.0 | 55.0 | 20.0 | 5.0  | 4.0  | 4.0 | 2.0 |
| 893.0 | 160.0 | 54.0 | 20.0 | 13.0 | 4.0  | .0  | 3.0 |
| 885.0 | 160.0 | 32.0 | 12.0 | 12.0 | 7.0  | 2.0 | 3.0 |
| 843.0 | 138.0 | 44.0 | 27.0 | 9.0  | 6.0  | 1.0 | 2.0 |
| 923.0 | 147.0 | 67.0 | 18.0 | 6.0  | 8.0  | 2.0 | 3.0 |
| 903.0 | 170.0 | 46.0 | 29.0 | 15.0 | 6.0  | 4.0 | 2.0 |

0 LOCATION: 4 NOZZLE PRESSURE: 2.5  
 F SETTING: 1.5 HOOD OPENING: 3.0  
 SAMPLE TIME: 300.

|       |      |      |     |     |     |     |     |
|-------|------|------|-----|-----|-----|-----|-----|
| 263.0 | 63.0 | 18.0 | 3.0 | 3.0 | 1.0 | .0  | 1.0 |
| 291.0 | 65.0 | 23.0 | 6.0 | 6.0 | 2.0 | .0  | .0  |
| 246.0 | 50.0 | 21.0 | 7.0 | 4.0 | 3.0 | .0  | 1.0 |
| 258.0 | 52.0 | 14.0 | 7.0 | 6.0 | .0  | .0  | .0  |
| 222.0 | 54.0 | 14.0 | 6.0 | 2.0 | 1.0 | .0  | 1.0 |
| 245.0 | 48.0 | 18.0 | 4.0 | 4.0 | 2.0 | 2.0 | .0  |

|       |      |      |      |     |     |     |     |
|-------|------|------|------|-----|-----|-----|-----|
| 303.0 | 68.0 | 20.0 | 11.0 | 4.0 | 1.0 | .0  | .0  |
| 309.0 | 42.0 | 17.0 | 4.0  | 3.0 | 2.0 | .0  | .0  |
| 263.0 | 55.0 | 10.0 | 7.0  | 4.0 | 3.0 | .0  | .0  |
| 233.0 | 49.0 | 15.0 | 4.0  | 1.0 | 2.0 | 2.0 | .0  |
| 231.0 | 62.0 | 15.0 | 8.0  | 1.0 | .0  | 1.0 | .0  |
| 236.0 | 57.0 | 15.0 | 9.0  | 3.0 | .0  | 1.0 | .0  |
| 231.0 | 52.0 | 22.0 | 11.0 | 3.0 | 1.0 | .0  | .0  |
| 301.0 | 47.0 | 12.0 | 8.0  | 2.0 | .0  | .0  | .0  |
| 295.0 | 52.0 | 16.0 | 9.0  | 1.0 | 2.0 | 1.0 | .0  |
| 254.0 | 48.0 | 19.0 | 11.0 | 1.0 | .0  | .0  | .0  |
| 242.0 | 45.0 | 17.0 | 9.0  | 4.0 | 1.0 | 1.0 | .0  |
| 237.0 | 58.0 | 20.0 | 7.0  | 3.0 | 2.0 | 1.0 | .0  |
| 271.0 | 52.0 | 19.0 | 6.0  | 2.0 | 1.0 | 1.0 | 1.0 |
| 244.0 | 67.0 | 17.0 | 5.0  | 2.0 | .0  | .0  | .0  |
| 254.0 | 53.0 | 16.0 | 5.0  | 6.0 | 1.0 | .0  | .0  |
| 280.0 | 47.0 | 13.0 | 7.0  | 5.0 | 2.0 | .0  | .0  |
| 260.0 | 52.0 | 26.0 | 9.0  | 5.0 | 1.0 | 1.0 | 1.0 |
| 270.0 | 51.0 | 25.0 | 8.0  | 7.0 | .0  | 2.0 | .0  |
| 195.0 | 56.0 | 13.0 | 9.0  | 2.0 | .0  | .0  | .0  |

0 LOCATION: 13 NOZZLE PRESSURE: 2.5  
 F. SETTING: 1.5 HOOD OPENING: 3.0  
 SAMPLE TIME: 300.

|       |      |      |     |     |     |     |     |
|-------|------|------|-----|-----|-----|-----|-----|
| 337.0 | 55.0 | 19.0 | 2.0 | 4.0 | 1.0 | 1.0 | .0  |
| 338.0 | 55.0 | 14.0 | 6.0 | .0  | .0  | 1.0 | .0  |
| 316.0 | 54.0 | 14.0 | 3.0 | 1.0 | .0  | .0  | .0  |
| 324.0 | 59.0 | 13.0 | 1.0 | 2.0 | 2.0 | 1.0 | .0  |
| 359.0 | 66.0 | 22.0 | 2.0 | 3.0 | 1.0 | 1.0 | .0  |
| 369.0 | 60.0 | 13.0 | 2.0 | .0  | .0  | .0  | .0  |
| 322.0 | 36.0 | 17.0 | 4.0 | 1.0 | 1.0 | .0  | .0  |
| 317.0 | 51.0 | 9.0  | 5.0 | 1.0 | 2.0 | 1.0 | .0  |
| 306.0 | 42.0 | 21.0 | 3.0 | 6.0 | 2.0 | .0  | .0  |
| 318.0 | 51.0 | 10.0 | 4.0 | .0  | .0  | .0  | 1.0 |
| 320.0 | 59.0 | 18.0 | 3.0 | .0  | .0  | .0  | .0  |
| 322.0 | 52.0 | 14.0 | 2.0 | 4.0 | 1.0 | 1.0 | .0  |
| 307.0 | 40.0 | 12.0 | 3.0 | 3.0 | 2.0 | .0  | 1.0 |
| 265.0 | 39.0 | 16.0 | 2.0 | 1.0 | .0  | 2.0 | .0  |
| 322.0 | 48.0 | 9.0  | 5.0 | 3.0 | 1.0 | .0  | .0  |
| 292.0 | 35.0 | 9.0  | 1.0 | 1.0 | 1.0 | .0  | .0  |
| 310.0 | 53.0 | 18.0 | 7.0 | 1.0 | 2.0 | 1.0 | 2.0 |
| 304.0 | 69.0 | 15.0 | 7.0 | 2.0 | .0  | .0  | .0  |
| 268.0 | 44.0 | 14.0 | 3.0 | .0  | .0  | .0  | .0  |
| 301.0 | 42.0 | 16.0 | 3.0 | 3.0 | 1.0 | .0  | .0  |
| 300.0 | 45.0 | 8.0  | 2.0 | 3.0 | 1.0 | .0  | .0  |
| 329.0 | 67.0 | 12.0 | 2.0 | 4.0 | 1.0 | .0  | .0  |
| 372.0 | 35.0 | 14.0 | 5.0 | 4.0 | 1.0 | .0  | .0  |
| 346.0 | 58.0 | 14.0 | 4.0 | .0  | 2.0 | .0  | .0  |
| 334.0 | 48.0 | 13.0 | 4.0 | 2.0 | 2.0 | .0  | .0  |

0 LOCATION: 22 NOZZLE PRESSURE: 2.5  
 F. SETTING: 1.5 HOOD OPENING: 3.0  
 SAMPLE TIME: 300.

|       |      |      |      |     |     |     |     |
|-------|------|------|------|-----|-----|-----|-----|
| 399.0 | 89.0 | 28.0 | 11.0 | 6.0 | 4.0 | .0  | .0  |
| 402.0 | 77.0 | 33.0 | 14.0 | 5.0 | 3.0 | .0  | .0  |
| 411.0 | 91.0 | 21.0 | 12.0 | 1.0 | 1.0 | 4.0 | 3.0 |

|       |       |      |      |     |     |     |     |
|-------|-------|------|------|-----|-----|-----|-----|
| 416.0 | 90.0  | 21.0 | 6.0  | 4.0 | 3.0 | 1.0 | 1.0 |
| 433.0 | 77.0  | 22.0 | 14.0 | 2.0 | 3.0 | .0  | 1.0 |
| 448.0 | 82.0  | 39.0 | 13.0 | 3.0 | 1.0 | 1.0 | .0  |
| 399.0 | 78.0  | 26.0 | 6.0  | 6.0 | 1.0 | 2.0 | .0  |
| 361.0 | 85.0  | 35.0 | 12.0 | 4.0 | 1.0 | 3.0 | 1.0 |
| 459.0 | 100.0 | 33.0 | 7.0  | 3.0 | 3.0 | 2.0 | 2.0 |
| 461.0 | 91.0  | 27.0 | 4.0  | 2.0 | 1.0 | .0  | .0  |
| 390.0 | 73.0  | 24.0 | 16.0 | 6.0 | 1.0 | 2.0 | .0  |
| 412.0 | 84.0  | 21.0 | 9.0  | 3.0 | 2.0 | .0  | 1.0 |
| 433.0 | 93.0  | 25.0 | 12.0 | 5.0 | 2.0 | 2.0 | .0  |
| 425.0 | 106.0 | 25.0 | 6.0  | 8.0 | 3.0 | .0  | 1.0 |
| 436.0 | 77.0  | 29.0 | 7.0  | 4.0 | 2.0 | 2.0 | 2.0 |
| 414.0 | 72.0  | 25.0 | 7.0  | 3.0 | 4.0 | .0  | .0  |
| 455.0 | 79.0  | 24.0 | 9.0  | 4.0 | 5.0 | 1.0 | 1.0 |
| 409.0 | 89.0  | 30.0 | 15.0 | 4.0 | 5.0 | 2.0 | 2.0 |
| 380.0 | 100.0 | 30.0 | 12.0 | 2.0 | 3.0 | .0  | 1.0 |
| 460.0 | 95.0  | 18.0 | 8.0  | 5.0 | 4.0 | .0  | 2.0 |
| 486.0 | 109.0 | 27.0 | 11.0 | 4.0 | 2.0 | 2.0 | 1.0 |
| 415.0 | 102.0 | 28.0 | 10.0 | 7.0 | 2.0 | 2.0 | .0  |

0 LOCATION: 49 NOZZLE PRESSURE: 2.5  
 F SETTING: 1.5 HOOD OPENING: 3.0  
 SAMPLE TIME: 300.

|       |       |      |      |      |     |     |     |
|-------|-------|------|------|------|-----|-----|-----|
| 538.0 | 103.0 | 36.0 | 16.0 | 7.0  | 2.0 | 2.0 | 1.0 |
| 533.0 | 103.0 | 41.0 | 10.0 | 11.0 | 4.0 | .0  | 1.0 |
| 558.0 | 135.0 | 40.0 | 15.0 | 10.0 | 1.0 | 5.0 | 1.0 |
| 519.0 | 110.0 | 37.0 | 8.0  | 9.0  | 1.0 | 1.0 | 2.0 |
| 520.0 | 106.0 | 39.0 | 6.0  | 6.0  | 2.0 | .0  | 1.0 |
| 520.0 | 121.0 | 40.0 | 18.0 | 6.0  | 2.0 | 2.0 | .0  |
| 511.0 | 113.0 | 31.0 | 22.0 | 13.0 | 1.0 | 4.0 | .0  |
| 440.0 | 96.0  | 27.0 | 13.0 | 7.0  | 4.0 | 8.0 | .0  |
| 494.0 | 90.0  | 42.0 | 17.0 | 8.0  | 4.0 | 2.0 | .0  |
| 475.0 | 88.0  | 31.0 | 9.0  | 4.0  | 5.0 | 2.0 | .0  |
| 518.0 | 121.0 | 39.0 | 21.0 | 14.0 | 2.0 | 1.0 | 1.0 |
| 513.0 | 99.0  | 35.0 | 17.0 | 5.0  | 2.0 | 2.0 | 2.0 |
| 522.0 | 108.0 | 41.0 | 13.0 | 4.0  | 3.0 | 1.0 | .0  |
| 521.0 | 109.0 | 29.0 | 12.0 | 1.0  | 2.0 | 2.0 | 2.0 |
| 500.0 | 97.0  | 41.0 | 17.0 | 1.0  | 1.0 | .0  | .0  |
| 523.0 | 110.0 | 39.0 | 13.0 | 9.0  | 3.0 | 2.0 | .0  |
| 531.0 | 105.0 | 33.0 | 16.0 | 10.0 | 2.0 | 3.0 | 1.0 |
| 538.0 | 115.0 | 42.0 | 11.0 | 7.0  | 2.0 | 1.0 | .0  |
| 454.0 | 114.0 | 43.0 | 12.0 | 7.0  | .0  | 2.0 | .0  |
| 535.0 | 124.0 | 42.0 | 17.0 | 8.0  | 2.0 | 3.0 | .0  |
| 523.0 | 128.0 | 40.0 | 11.0 | 4.0  | 4.0 | 3.0 | .0  |
| 541.0 | 111.0 | 41.0 | 10.0 | 7.0  | 1.0 | 3.0 | 2.0 |
| 542.0 | 118.0 | 35.0 | 17.0 | 4.0  | 2.0 | .0  | .0  |
| 558.0 | 110.0 | 31.0 | 9.0  | 13.0 | 5.0 | 1.0 | 1.0 |

0 LOCATION: 20 NOZZLE PRESSURE: 2.5  
 F SETTING: 1.5 HOOD OPENING: 3.0  
 SAMPLE TIME: 300.

|       |      |      |      |     |     |     |     |
|-------|------|------|------|-----|-----|-----|-----|
| 460.0 | 76.0 | 29.0 | 10.0 | 3.0 | 3.0 | 2.0 | 1.0 |
| 464.0 | 98.0 | 30.0 | 8.0  | 2.0 | 2.0 | 2.0 | 1.0 |
| 432.0 | 85.0 | 24.0 | 6.0  | 4.0 | 1.0 | 1.0 | 5.0 |
| 439.0 | 86.0 | 25.0 | 7.0  | 8.0 | 3.0 | 1.0 | 2.0 |

|       |      |      |      |     |     |     |     |
|-------|------|------|------|-----|-----|-----|-----|
| 468.0 | 71.0 | 20.0 | 16.0 | 6.0 | 2.0 | 2.0 | .0  |
| 462.0 | 76.0 | 32.0 | 15.0 | 7.0 | 1.0 | 1.0 | .0  |
| 428.0 | 81.0 | 37.0 | 7.0  | 8.0 | .0  | .0  | 1.0 |
| 449.0 | 76.0 | 32.0 | 13.0 | 7.0 | 5.0 | .0  | 2.0 |
| 424.0 | 90.0 | 27.0 | 15.0 | 2.0 | 5.0 | 3.0 | .0  |
| 410.0 | 92.0 | 28.0 | 9.0  | 8.0 | 1.0 | 2.0 | 2.0 |
| 444.0 | 79.0 | 24.0 | 11.0 | 3.0 | 1.0 | 1.0 | .0  |
| 413.0 | 85.0 | 33.0 | 14.0 | 5.0 | 4.0 | 1.0 | .0  |
| 413.0 | 69.0 | 21.0 | 10.0 | 4.0 | 3.0 | 2.0 | 1.0 |
| 421.0 | 91.0 | 22.0 | 12.0 | 1.0 | 2.0 | .0  | 1.0 |
| 442.0 | 70.0 | 29.0 | 14.0 | 2.0 | 3.0 | 2.0 | .0  |
| 487.0 | 78.0 | 36.0 | 15.0 | 2.0 | 2.0 | 1.0 | .0  |
| 392.0 | 82.0 | 24.0 | 14.0 | 5.0 | 3.0 | 1.0 | .0  |
| 391.0 | 83.0 | 21.0 | 10.0 | 4.0 | 4.0 | .0  | .0  |
| 482.0 | 96.0 | 28.0 | 13.0 | 2.0 | 1.0 | 3.0 | 1.0 |
| 438.0 | 90.0 | 31.0 | 7.0  | 9.0 | 1.0 | 3.0 | .0  |

0 LOCATION: 29 NOZZLE PRESSURE: 2.5  
 F. SETTING: 1.5 HOOD OPENING: 3.0  
 SAMPLE TIME: 300.

|       |      |      |      |     |     |     |     |
|-------|------|------|------|-----|-----|-----|-----|
| 387.0 | 59.0 | 15.0 | 8.0  | 3.0 | 1.0 | .0  | .0  |
| 399.0 | 87.0 | 17.0 | 5.0  | 3.0 | 5.0 | 1.0 | .0  |
| 346.0 | 69.0 | 22.0 | 4.0  | 5.0 | .0  | .0  | .0  |
| 371.0 | 61.0 | 22.0 | 13.0 | 5.0 | 6.0 | 1.0 | 2.0 |
| 372.0 | 67.0 | 29.0 | 11.0 | 4.0 | .0  | .0  | .0  |
| 437.0 | 65.0 | 26.0 | 15.0 | 4.0 | 2.0 | .0  | .0  |
| 364.0 | 62.0 | 17.0 | 6.0  | 4.0 | .0  | .0  | .0  |
| 373.0 | 73.0 | 25.0 | 6.0  | 6.0 | 1.0 | .0  | .0  |
| 384.0 | 69.0 | 17.0 | 6.0  | 2.0 | 1.0 | 1.0 | .0  |
| 367.0 | 55.0 | 13.0 | 4.0  | 4.0 | 4.0 | 1.0 | .0  |
| 361.0 | 62.0 | 17.0 | 7.0  | 9.0 | 2.0 | .0  | .0  |
| 382.0 | 64.0 | 18.0 | 5.0  | 4.0 | 2.0 | .0  | 1.0 |
| 380.0 | 69.0 | 22.0 | 7.0  | 4.0 | 2.0 | .0  | 1.0 |
| 362.0 | 76.0 | 15.0 | 13.0 | 1.0 | 2.0 | 1.0 | .0  |
| 390.0 | 75.0 | 24.0 | 10.0 | 6.0 | 1.0 | .0  | .0  |
| 382.0 | 77.0 | 21.0 | 3.0  | 2.0 | 2.0 | .0  | .0  |
| 342.0 | 47.0 | 25.0 | 12.0 | 5.0 | 1.0 | .0  | 1.0 |
| 411.0 | 71.0 | 21.0 | 6.0  | 5.0 | .0  | .0  | .0  |
| 374.0 | 95.0 | 27.0 | 11.0 | 3.0 | 5.0 | 2.0 | 1.0 |
| 369.0 | 63.0 | 27.0 | 12.0 | 8.0 | 2.0 | 3.0 | .0  |
| 383.0 | 71.0 | 24.0 | 7.0  | 4.0 | 1.0 | 1.0 | .0  |
| 347.0 | 65.0 | 26.0 | 1.0  | 1.0 | 4.0 | 3.0 | 1.0 |
| 407.0 | 77.0 | 27.0 | 12.0 | 3.0 | 5.0 | .0  | .0  |

0 LOCATION: 37 NOZZLE PRESSURE: 2.5  
 F. SETTING: 1.5 HOOD OPENING: 3.0  
 SAMPLE TIME: 300.

|       |       |      |      |      |     |     |     |
|-------|-------|------|------|------|-----|-----|-----|
| 577.0 | 122.0 | 36.0 | 12.0 | 7.0  | 2.0 | .0  | .0  |
| 583.0 | 123.0 | 37.0 | 12.0 | 3.0  | 5.0 | 1.0 | .0  |
| 536.0 | 118.0 | 37.0 | 11.0 | 2.0  | 6.0 | 7.0 | 1.0 |
| 599.0 | 97.0  | 29.0 | 10.0 | 3.0  | 4.0 | 3.0 | 2.0 |
| 568.0 | 89.0  | 42.0 | 17.0 | 8.0  | 3.0 | .0  | 1.0 |
| 569.0 | 107.0 | 36.0 | 12.0 | 2.0  | 5.0 | 2.0 | 1.0 |
| 595.0 | 115.0 | 41.0 | 12.0 | 10.0 | 1.0 | 2.0 | 2.0 |
| 598.0 | 108.0 | 37.0 | 12.0 | 7.0  | 4.0 | 1.0 | 3.0 |

|       |       |      |      |      |     |     |     |
|-------|-------|------|------|------|-----|-----|-----|
| 581.0 | 114.0 | 32.0 | 12.0 | 7.0  | 3.0 | 2.0 | .0  |
| 600.0 | 109.0 | 31.0 | 22.0 | 7.0  | 3.0 | 2.0 | .0  |
| 527.0 | 94.0  | 26.0 | 14.0 | 5.0  | .0  | 1.0 | .0  |
| 612.0 | 107.0 | 36.0 | 16.0 | 2.0  | 2.0 | .0  | .0  |
| 518.0 | 95.0  | 26.0 | 14.0 | 7.0  | 3.0 | 4.0 | 2.0 |
| 550.0 | 112.0 | 38.0 | 20.0 | 6.0  | 4.0 | 2.0 | 3.0 |
| 591.0 | 111.0 | 37.0 | 14.0 | 7.0  | .0  | .0  | 1.0 |
| 556.0 | 98.0  | 33.0 | 12.0 | 4.0  | 5.0 | 1.0 | 1.0 |
| 575.0 | 114.0 | 43.0 | 10.0 | 10.0 | 3.0 | 4.0 | .0  |
| 568.0 | 122.0 | 38.0 | 11.0 | 8.0  | 2.0 | 2.0 | .0  |
| 532.0 | 126.0 | 38.0 | 20.0 | 4.0  | 4.0 | 3.0 | 3.0 |
| 596.0 | 108.0 | 32.0 | 14.0 | 4.0  | 5.0 | 3.0 | .0  |
| 602.0 | 120.0 | 24.0 | 8.0  | 10.0 | 1.0 | 3.0 | .0  |
| 549.0 | 67.0  | 28.0 | 10.0 | 7.0  | 3.0 | 1.0 | 3.0 |
| 524.0 | 108.0 | 23.0 | 10.0 | 4.0  | 5.0 | 1.0 | .0  |
| 580.0 | 106.0 | 41.0 | 18.0 | 9.0  | 3.0 | 3.0 | 3.0 |
| 548.0 | 105.0 | 49.0 | 11.0 | 6.0  | 4.0 | 2.0 | 2.0 |

0 LOCATION: 31 NOZZLE PRESSURE: 2.5  
 F SETTING: 1.5 HOOD OPENING: 3.0  
 SAMPLE TIME: 300.

|       |      |      |      |     |     |     |     |
|-------|------|------|------|-----|-----|-----|-----|
| 316.0 | 63.0 | 22.0 | 14.0 | 4.0 | 3.0 | .0  | .0  |
| 324.0 | 72.0 | 27.0 | 10.0 | 7.0 | 3.0 | .0  | 1.0 |
| 312.0 | 71.0 | 24.0 | 15.0 | 2.0 | 4.0 | 2.0 | .0  |
| 300.0 | 75.0 | 32.0 | 7.0  | 1.0 | 2.0 | 1.0 | .0  |
| 288.0 | 70.0 | 26.0 | 16.0 | 3.0 | 3.0 | .0  | 2.0 |
| 302.0 | 82.0 | 21.0 | 9.0  | 2.0 | 4.0 | 2.0 | .0  |
| 313.0 | 67.0 | 27.0 | 6.0  | 7.0 | 1.0 | .0  | .0  |
| 327.0 | 80.0 | 30.0 | 13.0 | 8.0 | 3.0 | 1.0 | .0  |
| 297.0 | 72.0 | 23.0 | 15.0 | 4.0 | .0  | .0  | .0  |
| 275.0 | 70.0 | 17.0 | 7.0  | 7.0 | 2.0 | .0  | .0  |
| 308.0 | 74.0 | 30.0 | 9.0  | 2.0 | 5.0 | .0  | .0  |
| 312.0 | 75.0 | 21.0 | 5.0  | 1.0 | 1.0 | .0  | .0  |
| 312.0 | 69.0 | 24.0 | 9.0  | 1.0 | 2.0 | .0  | 1.0 |
| 357.0 | 68.0 | 32.0 | 12.0 | 8.0 | 4.0 | 2.0 | .0  |
| 340.0 | 63.0 | 18.0 | 10.0 | 4.0 | 3.0 | 3.0 | 1.0 |
| 321.0 | 59.0 | 29.0 | 9.0  | 3.0 | 5.0 | .0  | .0  |
| 297.0 | 85.0 | 32.0 | 8.0  | 6.0 | 3.0 | 1.0 | .0  |
| 329.0 | 61.0 | 22.0 | 8.0  | 1.0 | 1.0 | 1.0 | .0  |
| 315.0 | 79.0 | 31.0 | 11.0 | 4.0 | 1.0 | 2.0 | .0  |
| 290.0 | 66.0 | 23.0 | 5.0  | 6.0 | 1.0 | .0  | .0  |
| 335.0 | 80.0 | 33.0 | 8.0  | 9.0 | 3.0 | 3.0 | .0  |
| 337.0 | 72.0 | 28.0 | 7.0  | 3.0 | 2.0 | .0  | .0  |
| 342.0 | 76.0 | 35.0 | 7.0  | 7.0 | 4.0 | 3.0 | 1.0 |

0 LOCATION: 67 NOZZLE PRESSURE: 2.5  
 F SETTING: 1.5 HOOD OPENING: 3.0  
 SAMPLE TIME: 300.

|       |       |      |      |      |     |     |     |
|-------|-------|------|------|------|-----|-----|-----|
| 475.0 | 103.0 | 34.0 | 12.0 | 8.0  | 5.0 | 2.0 | .0  |
| 439.0 | 90.0  | 28.0 | 11.0 | 5.0  | .0  | 1.0 | .0  |
| 396.0 | 111.0 | 34.0 | 19.0 | 6.0  | 3.0 | .0  | .0  |
| 454.0 | 91.0  | 40.0 | 11.0 | 13.0 | 2.0 | 1.0 | 1.0 |
| 406.0 | 95.0  | 29.0 | 16.0 | 8.0  | 2.0 | 1.0 | 2.0 |
| 478.0 | 102.0 | 32.0 | 16.0 | 8.0  | 3.0 | 2.0 | 1.0 |
| 531.0 | 129.0 | 37.0 | 14.0 | 1.0  | 2.0 | .0  | 1.0 |

|       |       |      |      |      |     |     |     |
|-------|-------|------|------|------|-----|-----|-----|
| 476.0 | 111.0 | 37.0 | 14.0 | 5.0  | 5.0 | 1.0 | .0  |
| 460.0 | 106.0 | 33.0 | 14.0 | 5.0  | 3.0 | .0  | 1.0 |
| 467.0 | 113.0 | 35.0 | 12.0 | 9.0  | 2.0 | 2.0 | .0  |
| 488.0 | 82.0  | 34.0 | 6.0  | 6.0  | .0  | .0  | .0  |
| 456.0 | 96.0  | 53.0 | 13.0 | 6.0  | 1.0 | .0  | 1.0 |
| 468.0 | 115.0 | 33.0 | 11.0 | 5.0  | 2.0 | .0  | 2.0 |
| 493.0 | 110.0 | 37.0 | 12.0 | 6.0  | .0  | .0  | .0  |
| 427.0 | 105.0 | 33.0 | 15.0 | 6.0  | 7.0 | 4.0 | 1.0 |
| 449.0 | 106.0 | 34.0 | 12.0 | 3.0  | 6.0 | 1.0 | .0  |
| 433.0 | 77.0  | 38.0 | 14.0 | 5.0  | 3.0 | 2.0 | .0  |
| 462.0 | 99.0  | 30.0 | 4.0  | 10.0 | 2.0 | 2.0 | 1.0 |
| 482.0 | 96.0  | 29.0 | 14.0 | 7.0  | .0  | 2.0 | 2.0 |
| 492.0 | 103.0 | 23.0 | 14.0 | 5.0  | .0  | 2.0 | .0  |
| 500.0 | 97.0  | 23.0 | 13.0 | 6.0  | 5.0 | 1.0 | .0  |
| 433.0 | 81.0  | 32.0 | 7.0  | 2.0  | 2.0 | 1.0 | 2.0 |

0 LOCATION: 76 NOZZLE PRESSURE: 2.5  
 F SETTING: 1.5 HOOD OPENING: 3.0  
 SAMPLE TIME: 300.

|       |       |      |      |      |      |     |     |
|-------|-------|------|------|------|------|-----|-----|
| 641.0 | 153.0 | 42.0 | 17.0 | 11.0 | 9.0  | 9.0 | 1.0 |
| 621.0 | 136.0 | 45.0 | 17.0 | 5.0  | 7.0  | .0  | 2.0 |
| 630.0 | 145.0 | 34.0 | 14.0 | 5.0  | 3.0  | 3.0 | 1.0 |
| 652.0 | 162.0 | 45.0 | 21.0 | 16.0 | 7.0  | 5.0 | 2.0 |
| 616.0 | 135.0 | 41.0 | 30.0 | 6.0  | 5.0  | 2.0 | 1.0 |
| 672.0 | 155.0 | 44.0 | 20.0 | 8.0  | 7.0  | 2.0 | 1.0 |
| 592.0 | 146.0 | 51.0 | 31.0 | 9.0  | 6.0  | 5.0 | .0  |
| 690.0 | 135.0 | 51.0 | 25.0 | 13.0 | 2.0  | 2.0 | 1.0 |
| 706.0 | 170.0 | 57.0 | 22.0 | 8.0  | 7.0  | 1.0 | .0  |
| 706.0 | 174.0 | 57.0 | 18.0 | 11.0 | 8.0  | 4.0 | 1.0 |
| 665.0 | 162.0 | 54.0 | 29.0 | 9.0  | 5.0  | 3.0 | 2.0 |
| 640.0 | 132.0 | 47.0 | 33.0 | 9.0  | 6.0  | 1.0 | 2.0 |
| 632.0 | 157.0 | 59.0 | 21.0 | 10.0 | 11.0 | 2.0 | 1.0 |
| 596.0 | 119.0 | 54.0 | 12.0 | 17.0 | 7.0  | 1.0 | 3.0 |
| 725.0 | 163.0 | 52.0 | 18.0 | 14.0 | 2.0  | 2.0 | 2.0 |
| 668.0 | 154.0 | 45.0 | 18.0 | 9.0  | 2.0  | 2.0 | 3.0 |
| 695.0 | 141.0 | 42.0 | 26.0 | 9.0  | 4.0  | 4.0 | 2.0 |
| 644.0 | 120.0 | 63.0 | 23.0 | 13.0 | 9.0  | 5.0 | .0  |
| 619.0 | 131.0 | 45.0 | 18.0 | 12.0 | 1.0  | 4.0 | 3.0 |
| 623.0 | 163.0 | 47.0 | 23.0 | 11.0 | 2.0  | 6.0 | 2.0 |
| 597.0 | 114.0 | 41.0 | 17.0 | 9.0  | 10.0 | 3.0 | 3.0 |
| 616.0 | 158.0 | 55.0 | 18.0 | 12.0 | 5.0  | 3.0 | 2.0 |
| 591.0 | 148.0 | 51.0 | 21.0 | 15.0 | 3.0  | 2.0 | 1.0 |
| 603.0 | 165.0 | 53.0 | 24.0 | 10.0 | 8.0  | 3.0 | 2.0 |
| 669.0 | 152.0 | 48.0 | 22.0 | 12.0 | 7.0  | 2.0 | 3.0 |
| 636.0 | 178.0 | 63.0 | 25.0 | 11.0 | 5.0  | 4.0 | 2.0 |
| 641.0 | 157.0 | 48.0 | 27.0 | 7.0  | 4.0  | .0  | 1.0 |
| 657.0 | 142.0 | 50.0 | 16.0 | 11.0 | 7.0  | 6.0 | 5.0 |

0 LOCATION: 56 NOZZLE PRESSURE: 2.5  
 F SETTING: 1.5 HOOD OPENING: 3.0  
 SAMPLE TIME: 300

|       |       |      |      |      |     |     |     |
|-------|-------|------|------|------|-----|-----|-----|
| 372.0 | 121.0 | 42.0 | 19.0 | 4.0  | 7.0 | .0  | 1.0 |
| 370.0 | 95.0  | 39.0 | 22.0 | 9.0  | 1.0 | 3.0 | 1.0 |
| 338.0 | 84.0  | 29.0 | 20.0 | 12.0 | 5.0 | 2.0 | .0  |
| 324.0 | 94.0  | 42.0 | 13.0 | 8.0  | 4.0 | 1.0 | 1.0 |

|       |       |      |      |      |     |     |     |
|-------|-------|------|------|------|-----|-----|-----|
| 302.0 | 96.0  | 31.0 | 22.0 | 6.0  | 5.0 | .0  | 2.0 |
| 313.0 | 114.0 | 34.0 | 17.0 | 9.0  | 3.0 | 2.0 | .0  |
| 294.0 | 75.0  | 27.0 | 15.0 | 7.0  | 5.0 | 1.0 | .0  |
| 301.0 | 75.0  | 44.0 | 14.0 | 9.0  | 3.0 | 1.0 | 3.0 |
| 351.0 | 81.0  | 37.0 | 16.0 | 9.0  | 6.0 | 3.0 | .0  |
| 365.0 | 80.0  | 27.0 | 16.0 | 3.0  | 6.0 | 2.0 | 2.0 |
| 354.0 | 96.0  | 31.0 | 25.0 | 9.0  | 4.0 | 5.0 | 1.0 |
| 360.0 | 85.0  | 30.0 | 17.0 | 6.0  | 3.0 | 2.0 | 3.0 |
| 375.0 | 90.0  | 32.0 | 19.0 | 7.0  | 5.0 | 1.0 | .0  |
| 339.0 | 92.0  | 32.0 | 14.0 | 8.0  | 5.0 | 4.0 | 1.0 |
| 352.0 | 107.0 | 39.0 | 12.0 | 10.0 | 1.0 | 1.0 | 1.0 |
| 342.0 | 75.0  | 30.0 | 12.0 | 16.0 | 2.0 | 3.0 | .0  |
| 367.0 | 82.0  | 53.0 | 13.0 | 10.0 | 4.0 | .0  | 1.0 |
| 362.0 | 101.0 | 36.0 | 17.0 | 9.0  | 5.0 | .0  | 1.0 |
| 400.0 | 98.0  | 38.0 | 13.0 | 7.0  | 6.0 | 1.0 | .0  |
| 322.0 | 93.0  | 50.0 | 21.0 | 4.0  | 5.0 | 2.0 | 2.0 |
| 357.0 | 98.0  | 46.0 | 19.0 | 8.0  | 3.0 | 3.0 | .0  |

0 LOCATION: 56 NOZZLE PRESSURE: 2.5  
 F SETTING: 1.5 HOOD OPENING: 3.0  
 SAMPLE TIME: 300.

|       |       |      |      |      |      |     |     |
|-------|-------|------|------|------|------|-----|-----|
| 719.0 | 98.0  | 41.0 | 15.0 | 6.0  | 6.0  | 5.0 | 1.0 |
| 726.0 | 123.0 | 43.0 | 23.0 | 10.0 | 7.0  | 4.0 | 2.0 |
| 685.0 | 123.0 | 42.0 | 21.0 | 20.0 | 7.0  | 1.0 | 1.0 |
| 745.0 | 139.0 | 40.0 | 22.0 | 13.0 | 5.0  | 6.0 | 4.0 |
| 719.0 | 153.0 | 43.0 | 18.0 | 5.0  | 7.0  | 4.0 | 1.0 |
| 690.0 | 150.0 | 50.0 | 36.0 | 15.0 | 5.0  | 1.0 | 2.0 |
| 613.0 | 127.0 | 45.0 | 25.0 | 13.0 | 7.0  | 5.0 | 2.0 |
| 630.0 | 119.0 | 59.0 | 18.0 | 10.0 | 3.0  | 3.0 | 1.0 |
| 724.0 | 105.0 | 39.0 | 12.0 | 14.0 | 3.0  | 3.0 | 3.0 |
| 633.0 | 134.0 | 34.0 | 27.0 | 11.0 | 4.0  | 3.0 | 2.0 |
| 634.0 | 133.0 | 50.0 | 31.0 | 6.0  | 9.0  | 2.0 | .0  |
| 615.0 | 129.0 | 43.0 | 19.0 | 14.0 | 11.0 | 5.0 | 5.0 |
| 638.0 | 106.0 | 41.0 | 13.0 | 17.0 | 3.0  | 3.0 | 2.0 |
| 704.0 | 99.0  | 29.0 | 24.0 | 6.0  | 5.0  | 2.0 | 3.0 |
| 710.0 | 123.0 | 44.0 | 19.0 | 9.0  | 8.0  | 2.0 | 2.0 |
| 682.0 | 122.0 | 45.0 | 22.0 | 9.0  | 7.0  | 2.0 | 1.0 |
| 666.0 | 128.0 | 49.0 | 21.0 | 13.0 | 10.0 | 7.0 | 2.0 |
| 738.0 | 139.0 | 48.0 | 23.0 | 11.0 | 8.0  | 6.0 | .0  |
| 634.0 | 157.0 | 43.0 | 14.0 | 8.0  | 9.0  | 6.0 | 1.0 |
| 690.0 | 108.0 | 46.0 | 32.0 | 8.0  | 5.0  | 5.0 | 1.0 |
| 637.0 | 117.0 | 47.0 | 25.0 | 9.0  | 5.0  | 3.0 | 4.0 |
| 742.0 | 120.0 | 44.0 | 13.0 | 10.0 | 7.0  | 7.0 | 2.0 |
| 707.0 | 115.0 | 49.0 | 13.0 | 12.0 | 4.0  | 6.0 | 1.0 |
| 647.0 | 127.0 | 54.0 | 17.0 | 8.0  | 6.0  | 3.0 | 2.0 |
| 708.0 | 130.0 | 37.0 | 16.0 | 12.0 | 6.0  | 3.0 | 1.0 |

0 LOCATION: 65 NOZZLE PRESSURE: 2.5  
 F SETTING: 1.5 HOOD OPENING: 3.0  
 SAMPLE TIME: 300.

|       |       |      |      |      |     |     |     |
|-------|-------|------|------|------|-----|-----|-----|
| 624.0 | 102.0 | 29.0 | 13.0 | 6.0  | 7.0 | 1.0 | .0  |
| 646.0 | 123.0 | 31.0 | 8.0  | 10.0 | 3.0 | 3.0 | 3.0 |
| 636.0 | 115.0 | 45.0 | 16.0 | 6.0  | 8.0 | 4.0 | 2.0 |
| 616.0 | 111.0 | 38.0 | 16.0 | 8.0  | 2.0 | 5.0 | 1.0 |
| 637.0 | 118.0 | 36.0 | 14.0 | 6.0  | 6.0 | 1.0 | .0  |

|       |       |      |      |      |     |     |     |
|-------|-------|------|------|------|-----|-----|-----|
| 585.0 | 113.0 | 27.0 | 13.0 | 10.0 | 3.0 | 1.0 | 3.0 |
| 658.0 | 120.0 | 36.0 | 17.0 | 5.0  | 3.0 | 1.0 | .0  |
| 594.0 | 107.0 | 40.0 | 10.0 | 13.0 | 4.0 | 2.0 | 2.0 |
| 604.0 | 106.0 | 37.0 | 19.0 | 6.0  | 4.0 | 2.0 | 3.0 |
| 583.0 | 101.0 | 40.0 | 19.0 | 11.0 | 4.0 | 1.0 | 2.0 |
| 627.0 | 125.0 | 42.0 | 18.0 | 7.0  | 2.0 | 3.0 | 1.0 |
| 530.0 | 94.0  | 34.0 | 14.0 | 8.0  | 4.0 | 1.0 | .0  |
| 641.0 | 107.0 | 30.0 | 12.0 | 11.0 | 5.0 | 2.0 | 1.0 |
| 573.0 | 108.0 | 33.0 | 10.0 | 7.0  | .0  | 3.0 | .0  |
| 612.0 | 120.0 | 32.0 | 12.0 | 8.0  | 5.0 | 3.0 | 3.0 |
| 653.0 | 133.0 | 33.0 | 18.0 | 8.0  | 5.0 | 2.0 | .0  |
| 603.0 | 102.0 | 46.0 | 10.0 | 9.0  | 1.0 | 1.0 | 2.0 |
| 599.0 | 103.0 | 34.0 | 11.0 | 5.0  | 2.0 | 5.0 | 1.0 |
| 631.0 | 107.0 | 26.0 | 15.0 | 5.0  | 1.0 | 1.0 | 2.0 |
| 571.0 | 104.0 | 33.0 | 11.0 | 4.0  | 6.0 | 3.0 | 2.0 |

LOCATION: 38 NOZZLE PRESSURE: 2.5  
 F. SETTING: 1.5 HOOD OPENING: 3.0  
 SAMPLE TIME: 300.

|       |      |      |      |      |     |     |     |
|-------|------|------|------|------|-----|-----|-----|
| 476.0 | 86.0 | 20.0 | 11.0 | 4.0  | .0  | .0  | .0  |
| 461.0 | 78.0 | 34.0 | 11.0 | 8.0  | 2.0 | 1.0 | 1.0 |
| 404.0 | 63.0 | 23.0 | 9.0  | 8.0  | 1.0 | 1.0 | .0  |
| 432.0 | 61.0 | 19.0 | 4.0  | 7.0  | .0  | 2.0 | 2.0 |
| 422.0 | 86.0 | 21.0 | 12.0 | 10.0 | 3.0 | 2.0 | 1.0 |
| 421.0 | 63.0 | 18.0 | 9.0  | 4.0  | .0  | .0  | .0  |
| 465.0 | 79.0 | 20.0 | 6.0  | 7.0  | 1.0 | .0  | 1.0 |
| 437.0 | 79.0 | 19.0 | 7.0  | 1.0  | 3.0 | 1.0 | .0  |
| 431.0 | 81.0 | 27.0 | 3.0  | 4.0  | .0  | 1.0 | .0  |
| 460.0 | 66.0 | 17.0 | 4.0  | 5.0  | 2.0 | 1.0 | 1.0 |
| 464.0 | 93.0 | 18.0 | 7.0  | 1.0  | 4.0 | 1.0 | 1.0 |
| 416.0 | 73.0 | 24.0 | 10.0 | 5.0  | 1.0 | 1.0 | 1.0 |
| 437.0 | 68.0 | 27.0 | 10.0 | 7.0  | 1.0 | 1.0 | 1.0 |
| 388.0 | 72.0 | 20.0 | 10.0 | 6.0  | 3.0 | 2.0 | 1.0 |
| 436.0 | 69.0 | 31.0 | 3.0  | 6.0  | 3.0 | 2.0 | 1.0 |
| 451.0 | 67.0 | 29.0 | 4.0  | 7.0  | 5.0 | 1.0 | 1.0 |
| 505.0 | 75.0 | 22.0 | 16.0 | 7.0  | 1.0 | 2.0 | .0  |
| 389.0 | 70.0 | 15.0 | 5.0  | 9.0  | 1.0 | 3.0 | .0  |
| 450.0 | 74.0 | 23.0 | 5.0  | 7.0  | 1.0 | 1.0 | .0  |
| 432.0 | 84.0 | 21.0 | 10.0 | 6.0  | 1.0 | .0  | .0  |
| 447.0 | 79.0 | 24.0 | 6.0  | 7.0  | 2.0 | 3.0 | .0  |
| 463.0 | 59.0 | 26.0 | 4.0  | 7.0  | 1.0 | 1.0 | .0  |
| 458.0 | 74.0 | 24.0 | 5.0  | 5.0  | 2.0 | 1.0 | .0  |
| 442.0 | 80.0 | 31.0 | 7.0  | 4.0  | 3.0 | .0  | 1.0 |
| 439.0 | 82.0 | 21.0 | 10.0 | 3.0  | 1.0 | 4.0 | .0  |

LOCATION: 11 NOZZLE PRESSURE: 2.5  
 F. SETTING: 1.5 HOOD OPENING: 3.0  
 SAMPLE TIME: 300.

|       |      |      |     |     |     |     |     |
|-------|------|------|-----|-----|-----|-----|-----|
| 288.0 | 34.0 | 16.0 | 2.0 | 1.0 | .0  | 1.0 | .0  |
| 343.0 | 45.0 | 13.0 | 4.0 | 1.0 | 1.0 | .0  | 1.0 |
| 321.0 | 52.0 | 14.0 | 3.0 | 2.0 | 1.0 | 2.0 | 1.0 |
| 295.0 | 48.0 | 12.0 | 6.0 | 1.0 | 1.0 | 1.0 | .0  |
| 344.0 | 54.0 | 12.0 | 7.0 | 5.0 | .0  | .0  | 1.0 |
| 333.0 | 50.0 | 16.0 | 4.0 | 3.0 | .0  | .0  | 1.0 |
| 308.0 | 31.0 | 12.0 | 5.0 | 1.0 | 1.0 | .0  | .0  |



|       |      |      |     |     |     |     |     |
|-------|------|------|-----|-----|-----|-----|-----|
| 323.0 | 42.0 | 8.0  | 6.0 | 3.0 | .0  | 1.0 | .0  |
| 284.0 | 57.0 | 18.0 | 3.0 | .0  | 3.0 | .0  | .0  |
| 334.0 | 56.0 | 16.0 | 4.0 | 3.0 | .0  | .0  | .0  |
| 332.0 | 45.0 | 12.0 | 7.0 | 5.0 | .0  | 1.0 | 1.0 |
| 307.0 | 55.0 | 21.0 | 1.0 | 1.0 | 2.0 | .0  | 1.0 |
| 296.0 | 60.0 | 17.0 | 1.0 | 3.0 | 1.0 | .0  | .0  |
| 304.0 | 47.0 | 10.0 | 5.0 | 4.0 | 1.0 | .0  | 2.0 |
| 297.0 | 56.0 | 11.0 | 4.0 | 2.0 | 1.0 | .0  | .0  |
| 322.0 | 42.0 | 2.0  | 5.0 | 2.0 | .0  | 1.0 | .0  |
| 273.0 | 47.0 | 15.0 | 5.0 | 3.0 | .0  | 1.0 | .0  |
| 304.0 | 47.0 | 13.0 | 7.0 | 2.0 | 1.0 | 1.0 | .0  |
| 329.0 | 48.0 | 7.0  | 5.0 | 3.0 | 1.0 | .0  | .0  |
| 312.0 | 44.0 | 15.0 | 5.0 | 2.0 | 2.0 | 1.0 | .0  |
| 304.0 | 47.0 | 11.0 | 5.0 | .0  | 1.0 | 1.0 | .0  |

0 LOCATION: 30 NOZZLE PRESSURE: 2.5  
 F SETTING: 1.5 HOOD OPENING: 3.0  
 SAMPLE TIME: 300.

|       |      |      |     |     |     |     |     |
|-------|------|------|-----|-----|-----|-----|-----|
| 292.0 | 30.0 | 8.0  | 3.0 | 2.0 | .0  | .0  | .0  |
| 281.0 | 40.0 | 7.0  | 4.0 | .0  | .0  | .0  | .0  |
| 233.0 | 37.0 | 10.0 | 2.0 | 1.0 | .0  | 1.0 | 1.0 |
| 297.0 | 36.0 | 2.0  | 1.0 | 1.0 | .0  | 1.0 | .0  |
| 272.0 | 31.0 | 10.0 | 4.0 | .0  | 1.0 | .0  | .0  |
| 289.0 | 33.0 | 5.0  | 5.0 | 1.0 | .0  | .0  | .0  |
| 245.0 | 26.0 | 11.0 | 3.0 | .0  | 1.0 | .0  | .0  |
| 220.0 | 35.0 | 10.0 | 7.0 | .0  | .0  | .0  | .0  |
| 260.0 | 36.0 | 6.0  | 5.0 | .0  | .0  | .0  | .0  |
| 282.0 | 31.0 | 6.0  | 1.0 | .0  | 1.0 | .0  | .0  |
| 241.0 | 31.0 | 7.0  | 1.0 | .0  | .0  | 1.0 | .0  |
| 254.0 | 30.0 | 8.0  | 5.0 | 1.0 | .0  | .0  | .0  |
| 200.0 | 24.0 | 15.0 | 2.0 | 1.0 | .0  | .0  | .0  |
| 224.0 | 27.0 | 12.0 | 6.0 | 2.0 | .0  | .0  | .0  |
| 186.0 | 39.0 | 6.0  | 3.0 | .0  | .0  | .0  | .0  |
| 286.0 | 39.0 | 11.0 | 6.0 | 4.0 | .0  | .0  | .0  |
| 255.0 | 32.0 | 11.0 | 5.0 | 2.0 | 1.0 | .0  | 1.0 |
| 264.0 | 40.0 | 7.0  | 2.0 | .0  | .0  | .0  | .0  |
| 277.0 | 37.0 | 12.0 | 7.0 | .0  | .0  | .0  | .0  |
| 235.0 | 36.0 | 3.0  | 3.0 | 4.0 | .0  | .0  | .0  |
| 277.0 | 32.0 | 13.0 | 3.0 | 1.0 | .0  | .0  | .0  |
| 254.0 | 38.0 | 5.0  | 4.0 | .0  | 2.0 | .0  | .0  |
| 277.0 | 33.0 | 9.0  | 1.0 | 1.0 | .0  | .0  | .0  |
| 264.0 | 33.0 | 3.0  | 3.0 | .0  | .0  | .0  | .0  |
| 236.0 | 40.0 | 3.0  | 4.0 | 2.0 | .0  | .0  | .0  |
| 222.0 | 32.0 | 13.0 | 5.0 | .0  | 1.0 | 1.0 | .0  |
| 304.0 | 34.0 | 7.0  | 4.0 | 3.0 | .0  | .0  | .0  |

0 LOCATION: 39 NOZZLE PRESSURE: 2.5  
 F SETTING: 1.5 HOOD OPENING: 3.0  
 SAMPLE TIME: 300.

|       |      |      |     |     |     |     |     |
|-------|------|------|-----|-----|-----|-----|-----|
| 239.0 | 38.0 | 12.0 | 2.0 | .0  | 1.0 | .0  | 1.0 |
| 263.0 | 44.0 | 13.0 | 1.0 | 3.0 | .0  | .0  | .0  |
| 267.0 | 39.0 | 12.0 | 2.0 | 4.0 | 1.0 | 1.0 | 1.0 |
| 231.0 | 39.0 | 12.0 | 3.0 | .0  | 1.0 | 1.0 | .0  |
| 276.0 | 37.0 | 11.0 | 6.0 | 2.0 | .0  | .0  | 1.0 |
| 201.0 | 30.0 | 10.0 | 7.0 | 1.0 | 1.0 | .0  | 1.0 |

|       |      |      |     |     |     |     |     |
|-------|------|------|-----|-----|-----|-----|-----|
| 204.0 | 42.0 | 16.0 | 3.0 | 2.0 | .0  | .0  | .0  |
| 221.0 | 33.0 | 10.0 | 5.0 | 3.0 | 1.0 | 1.0 | .0  |
| 246.0 | 55.0 | 8.0  | 5.0 | 2.0 | 1.0 | .0  | .0  |
| 165.0 | 46.0 | 3.0  | 4.0 | 1.0 | 2.0 | .0  | .0  |
| 179.0 | 47.0 | 6.0  | 1.0 | 2.0 | .0  | .0  | .0  |
| 217.0 | 38.0 | 16.0 | 1.0 | 1.0 | 1.0 | 1.0 | .0  |
| 199.0 | 38.0 | 12.0 | 4.0 | .0  | .0  | 1.0 | .0  |
| 257.0 | 45.0 | 10.0 | 3.0 | .0  | 4.0 | .0  | .0  |
| 271.0 | 42.0 | 12.0 | .0  | 1.0 | 2.0 | .0  | .0  |
| 264.0 | 33.0 | 14.0 | 1.0 | 1.0 | 1.0 | .0  | .0  |
| 276.0 | 34.0 | 10.0 | 7.0 | 2.0 | 1.0 | .0  | .0  |
| 305.0 | 50.0 | 13.0 | 1.0 | 1.0 | 2.0 | 1.0 | 1.0 |
| 306.0 | 50.0 | 9.0  | 1.0 | 2.0 | 1.0 | .0  | .0  |
| 280.0 | 38.0 | 8.0  | 6.0 | .0  | .0  | 2.0 | .0  |
| 247.0 | 44.0 | 9.0  | 5.0 | 1.0 | 1.0 | .0  | .0  |
| 248.0 | 30.0 | 14.0 | 2.0 | 1.0 | 3.0 | 1.0 | .0  |
| 232.0 | 42.0 | 14.0 | 2.0 | 1.0 | 1.0 | .0  | .0  |
| 212.0 | 39.0 | 9.0  | 4.0 | 1.0 | 1.0 | .0  | .0  |
| 211.0 | 32.0 | 13.0 | 3.0 | .0  | 1.0 | 1.0 | .0  |

0 LOCATION: 57 NOZZLE PRESSURE: 2.5  
 F SETTING: 1.5 HOOD OPENING: 3.0  
 SAMPLE TIME: 300.

|       |      |      |      |     |     |     |     |
|-------|------|------|------|-----|-----|-----|-----|
| 379.0 | 57.0 | 17.0 | 6.0  | 1.0 | .0  | 1.0 | .0  |
| 356.0 | 48.0 | 25.0 | 6.0  | 3.0 | 1.0 | 1.0 | .0  |
| 267.0 | 61.0 | 17.0 | 10.0 | 5.0 | 1.0 | .0  | .0  |
| 271.0 | 40.0 | 18.0 | 8.0  | 1.0 | .0  | .0  | .0  |
| 293.0 | 47.0 | 12.0 | 6.0  | 1.0 | 1.0 | .0  | .0  |
| 295.0 | 46.0 | 22.0 | 8.0  | 1.0 | 1.0 | 2.0 | .0  |
| 305.0 | 50.0 | 15.0 | 1.0  | 3.0 | 1.0 | .0  | .0  |
| 387.0 | 62.0 | 26.0 | 3.0  | .0  | 2.0 | .0  | .0  |
| 385.0 | 63.0 | 14.0 | 3.0  | 1.0 | 2.0 | .0  | .0  |
| 348.0 | 72.0 | 19.0 | 6.0  | 2.0 | .0  | 1.0 | .0  |
| 335.0 | 48.0 | 17.0 | 7.0  | 3.0 | 3.0 | 2.0 | 1.0 |
| 365.0 | 71.0 | 8.0  | 7.0  | 3.0 | .0  | .0  | .0  |
| 369.0 | 52.0 | 19.0 | 3.0  | 2.0 | 1.0 | .0  | 1.0 |
| 321.0 | 52.0 | 15.0 | 7.0  | 4.0 | .0  | .0  | .0  |
| 329.0 | 56.0 | 17.0 | 7.0  | .0  | 1.0 | .0  | .0  |
| 247.0 | 43.0 | 16.0 | 7.0  | .0  | 1.0 | .0  | 1.0 |
| 289.0 | 61.0 | 23.0 | 8.0  | 2.0 | 2.0 | .0  | 1.0 |
| 308.0 | 49.0 | 12.0 | 7.0  | 2.0 | 1.0 | .0  | .0  |
| 360.0 | 65.0 | 12.0 | 7.0  | 1.0 | .0  | .0  | 1.0 |
| 353.0 | 53.0 | 16.0 | 3.0  | 1.0 | .0  | .0  | .0  |
| 368.0 | 58.0 | 19.0 | 5.0  | 3.0 | 1.0 | .0  | 1.0 |
| 374.0 | 61.0 | 12.0 | 5.0  | 3.0 | 2.0 | 1.0 | .0  |
| 345.0 | 65.0 | 12.0 | 8.0  | .0  | .0  | .0  | .0  |
| 350.0 | 47.0 | 8.0  | 3.0  | 1.0 | 1.0 | 1.0 | .0  |
| 338.0 | 52.0 | 20.0 | 7.0  | 2.0 | .0  | .0  | .0  |
| 325.0 | 69.0 | 6.0  | 10.0 | .0  | .0  | 2.0 | .0  |

0 LOCATION: 60 NOZZLE PRESSURE: 2.5  
 F SETTING: 1.5 HOOD OPENING: 3.0  
 SAMPLE TIME: 300.

|       |      |      |     |     |     |     |    |
|-------|------|------|-----|-----|-----|-----|----|
| 301.0 | 46.0 | 9.0  | 4.0 | 1.0 | 2.0 | 2.0 | .0 |
| 300.0 | 41.0 | 16.0 | 4.0 | 4.0 | 1.0 | 1.0 | .0 |

|       |      |      |     |     |     |     |     |
|-------|------|------|-----|-----|-----|-----|-----|
| 280.0 | 48.0 | 12.0 | 6.0 | 1.0 | 2.0 | .0  | 1.0 |
| 256.0 | 42.0 | 20.0 | 6.0 | 3.0 | .0  | 1.0 | .0  |
| 245.0 | 52.0 | 10.0 | 4.0 | 2.0 | .0  | 2.0 | 2.0 |
| 269.0 | 35.0 | 11.0 | 8.0 | 4.0 | 2.0 | .0  | .0  |
| 316.0 | 62.0 | 11.0 | 1.0 | 2.0 | 1.0 | .0  | .0  |
| 286.0 | 49.0 | 14.0 | 5.0 | 3.0 | 3.0 | 2.0 | .0  |
| 311.0 | 59.0 | 9.0  | 1.0 | 3.0 | 1.0 | .0  | .0  |
| 297.0 | 55.0 | 16.0 | 4.0 | 3.0 | .0  | .0  | .0  |
| 286.0 | 55.0 | 14.0 | 5.0 | 1.0 | .0  | .0  | 1.0 |
| 269.0 | 37.0 | 11.0 | 6.0 | 2.0 | 2.0 | 2.0 | .0  |
| 246.0 | 51.0 | 15.0 | 3.0 | 2.0 | 1.0 | .0  | 1.0 |
| 273.0 | 42.0 | 12.0 | 7.0 | 1.0 | 1.0 | 1.0 | .0  |
| 246.0 | 46.0 | 16.0 | 4.0 | .0  | 1.0 | .0  | .0  |
| 324.0 | 53.0 | 10.0 | 3.0 | 2.0 | 2.0 | .0  | 1.0 |
| 322.0 | 53.0 | 13.0 | 2.0 | 3.0 | .0  | .0  | 3.0 |
| 289.0 | 53.0 | 10.0 | 7.0 | 2.0 | 2.0 | .0  | .0  |
| 289.0 | 45.0 | 17.0 | 5.0 | 1.0 | 4.0 | 2.0 | .0  |
| 278.0 | 49.0 | 14.0 | 2.0 | 2.0 | .0  | .0  | 1.0 |
| 283.0 | 48.0 | 10.0 | 6.0 | 6.0 | .0  | 1.0 | .0  |
| 296.0 | 56.0 | 16.0 | 8.0 | 2.0 | 1.0 | 1.0 | .0  |
| 262.0 | 51.0 | 18.0 | 4.0 | 6.0 | 1.0 | .0  | 1.0 |
| 320.0 | 59.0 | 14.0 | 9.0 | 5.0 | 1.0 | .0  | .0  |
| 319.0 | 65.0 | 15.0 | 2.0 | 1.0 | 2.0 | 1.0 | 1.0 |
| 306.0 | 49.0 | 18.0 | 5.0 | 5.0 | 1.0 | .0  | .0  |

0 LOCATION: 75 NOZZLE PRESSURE: 2.5  
 F SETTING: 1.5 HOOD OPENING: 3.0  
 SAMPLE TIME: 300.

|       |       |      |      |      |     |     |     |
|-------|-------|------|------|------|-----|-----|-----|
| 560.0 | 114.0 | 36.0 | 8.0  | 7.0  | 1.0 | 4.0 | .0  |
| 552.0 | 109.0 | 36.0 | 21.0 | 3.0  | 4.0 | .0  | 2.0 |
| 582.0 | 103.0 | 35.0 | 16.0 | 10.0 | 2.0 | 2.0 | 3.0 |
| 485.0 | 119.0 | 28.0 | 5.0  | 5.0  | 4.0 | 2.0 | .0  |
| 466.0 | 104.0 | 35.0 | 16.0 | 6.0  | 2.0 | 1.0 | 1.0 |
| 517.0 | 111.0 | 31.0 | 10.0 | 2.0  | 5.0 | 2.0 | 1.0 |
| 575.0 | 106.0 | 36.0 | 15.0 | 6.0  | 3.0 | 1.0 | 2.0 |
| 527.0 | 110.0 | 49.0 | 9.0  | 7.0  | 1.0 | 1.0 | 2.0 |
| 577.0 | 120.0 | 32.0 | 12.0 | 7.0  | 4.0 | 2.0 | 1.0 |
| 521.0 | 115.0 | 30.0 | 16.0 | 5.0  | 1.0 | .0  | 1.0 |
| 514.0 | 129.0 | 49.0 | 16.0 | 8.0  | 3.0 | 3.0 | 2.0 |
| 583.0 | 112.0 | 24.0 | 10.0 | 7.0  | 1.0 | 2.0 | 2.0 |
| 480.0 | 114.0 | 29.0 | 17.0 | 4.0  | 5.0 | 1.0 | 1.0 |
| 559.0 | 116.0 | 36.0 | 17.0 | 6.0  | 2.0 | 2.0 | 1.0 |
| 532.0 | 85.0  | 29.0 | 11.0 | 8.0  | 3.0 | .0  | 1.0 |
| 521.0 | 98.0  | 35.0 | 15.0 | 10.0 | .0  | 4.0 | 2.0 |
| 497.0 | 107.0 | 39.0 | 8.0  | 7.0  | 3.0 | 3.0 | .0  |
| 547.0 | 116.0 | 37.0 | 14.0 | 5.0  | 2.0 | 1.0 | .0  |
| 581.0 | 114.0 | 41.0 | 9.0  | 7.0  | 5.0 | 3.0 | 2.0 |
| 544.0 | 117.0 | 39.0 | 8.0  | 4.0  | 3.0 | 1.0 | .0  |
| 581.0 | 101.0 | 33.0 | 15.0 | 7.0  | 2.0 | .0  | .0  |
| 577.0 | 117.0 | 37.0 | 14.0 | 8.0  | 1.0 | 1.0 | 1.0 |
| 585.0 | 121.0 | 30.0 | 17.0 | 3.0  | 4.0 | 3.0 | 2.0 |

0 LOCATION: 48 NOZZLE PRESSURE: 2.5  
 F SETTING: 1.5 HOOD OPENING: 3.0  
 SAMPLE TIME: 300.

|       |       |      |      |     |     |     |     |
|-------|-------|------|------|-----|-----|-----|-----|
| 446.0 | 74.0  | 24.0 | 10.0 | 2.0 | 4.0 | 4.0 | 2.0 |
| 454.0 | 69.0  | 19.0 | 4.0  | 4.0 | 3.0 | .0  | 2.0 |
| 417.0 | 74.0  | 22.0 | 8.0  | 4.0 | .0  | 1.0 | .0  |
| 407.0 | 80.0  | 29.0 | 9.0  | 4.0 | 1.0 | .0  | .0  |
| 369.0 | 95.0  | 33.0 | 9.0  | 3.0 | 3.0 | .0  | 1.0 |
| 457.0 | 75.0  | 29.0 | 5.0  | 3.0 | 3.0 | 2.0 | .0  |
| 463.0 | 80.0  | 23.0 | 11.0 | 1.0 | 3.0 | 1.0 | 1.0 |
| 441.0 | 106.0 | 27.0 | 8.0  | 7.0 | 6.0 | 1.0 | .0  |
| 430.0 | 94.0  | 22.0 | 6.0  | 4.0 | 2.0 | 1.0 | .0  |
| 434.0 | 79.0  | 33.0 | 10.0 | 2.0 | 2.0 | 1.0 | .0  |
| 429.0 | 83.0  | 19.0 | 10.0 | 4.0 | 3.0 | .0  | 2.0 |
| 403.0 | 85.0  | 22.0 | 8.0  | 3.0 | 1.0 | 2.0 | 2.0 |
| 431.0 | 77.0  | 25.0 | 6.0  | 5.0 | .0  | 1.0 | .0  |
| 462.0 | 87.0  | 19.0 | 8.0  | 2.0 | .0  | 1.0 | 2.0 |
| 409.0 | 70.0  | 36.0 | 11.0 | 6.0 | 2.0 | 2.0 | 1.0 |
| 486.0 | 91.0  | 25.0 | 11.0 | 2.0 | 2.0 | 1.0 | 1.0 |
| 510.0 | 85.0  | 16.0 | 7.0  | 2.0 | 2.0 | 2.0 | 1.0 |
| 425.0 | 69.0  | 17.0 | 10.0 | 5.0 | 2.0 | .0  | 1.0 |
| 459.0 | 75.0  | 22.0 | 3.0  | 2.0 | 1.0 | .0  | .0  |
| 437.0 | 82.0  | 19.0 | 9.0  | 4.0 | 5.0 | 1.0 | 1.0 |
| 449.0 | 86.0  | 24.0 | 7.0  | 2.0 | .0  | 2.0 | .0  |
| 428.0 | 85.0  | 15.0 | 9.0  | .0  | 1.0 | 1.0 | .0  |
| 486.0 | 87.0  | 29.0 | 10.0 | 7.0 | 2.0 | 1.0 | 1.0 |
| 530.0 | 105.0 | 23.0 | 10.0 | .0  | 5.0 | 1.0 | .0  |
| 471.0 | 85.0  | 21.0 | 12.0 | 3.0 | 2.0 | 2.0 | .0  |

0 LOCATION: 21 NOZZLE PRESSURE: 2.5  
 F SETTING: 1.5 HOOD OPENING: 3.0  
 SAMPLE TIME: 300.

|       |      |      |      |     |     |     |     |
|-------|------|------|------|-----|-----|-----|-----|
| 423.0 | 88.0 | 21.0 | 7.0  | 6.0 | 4.0 | 2.0 | 1.0 |
| 414.0 | 59.0 | 20.0 | 5.0  | 5.0 | 1.0 | .0  | .0  |
| 424.0 | 74.0 | 18.0 | 8.0  | 4.0 | 2.0 | .0  | .0  |
| 460.0 | 65.0 | 20.0 | 6.0  | 3.0 | 2.0 | .0  | .0  |
| 448.0 | 60.0 | 16.0 | 4.0  | 2.0 | 1.0 | 1.0 | .0  |
| 413.0 | 72.0 | 17.0 | 9.0  | 7.0 | 4.0 | .0  | 1.0 |
| 453.0 | 70.0 | 13.0 | 11.0 | 5.0 | 1.0 | .0  | 2.0 |
| 435.0 | 49.0 | 21.0 | 5.0  | 1.0 | 1.0 | 1.0 | 3.0 |
| 429.0 | 72.0 | 24.0 | 4.0  | 3.0 | 1.0 | 1.0 | 1.0 |
| 427.0 | 71.0 | 15.0 | 5.0  | 3.0 | .0  | 3.0 | .0  |
| 461.0 | 60.0 | 15.0 | 6.0  | 2.0 | 1.0 | 1.0 | .0  |
| 420.0 | 76.0 | 16.0 | 5.0  | 1.0 | 1.0 | 3.0 | 2.0 |
| 450.0 | 82.0 | 20.0 | 5.0  | 6.0 | 1.0 | 1.0 | .0  |
| 411.0 | 81.0 | 13.0 | 8.0  | 2.0 | 1.0 | 1.0 | 1.0 |
| 456.0 | 75.0 | 18.0 | 6.0  | 2.0 | 2.0 | .0  | .0  |
| 436.0 | 91.0 | 15.0 | 10.0 | 2.0 | 3.0 | .0  | .0  |
| 429.0 | 72.0 | 17.0 | 9.0  | 3.0 | 1.0 | .0  | 3.0 |
| 459.0 | 71.0 | 19.0 | 5.0  | 3.0 | 2.0 | 1.0 | .0  |
| 471.0 | 83.0 | 21.0 | 12.0 | .0  | 1.0 | 3.0 | .0  |
| 506.0 | 65.0 | 25.0 | 8.0  | 3.0 | .0  | .0  | .0  |
| 498.0 | 68.0 | 22.0 | 10.0 | 1.0 | 1.0 | 2.0 | 1.0 |
| 393.0 | 66.0 | 15.0 | 5.0  | 1.0 | 2.0 | 2.0 | .0  |
| 352.0 | 67.0 | 16.0 | 9.0  | 1.0 | 4.0 | 1.0 | 1.0 |
| 411.0 | 71.0 | 18.0 | 7.0  | 6.0 | 2.0 | .0  | .0  |
| 458.0 | 82.0 | 17.0 | 6.0  | 2.0 | 3.0 | .0  | 2.0 |
| 524.0 | 73.0 | 25.0 | 5.0  | 2.0 | 3.0 | .0  | 1.0 |

0 LOCATION: 3 NOZZLE PRESSURE: 2.5

F SETTING: 1.5      HOOD OPENING: 3.0  
 SAMPLE TIME: 300.

|       |      |      |     |     |     |     |     |
|-------|------|------|-----|-----|-----|-----|-----|
| 197.0 | 31.0 | 8.0  | .0  | 1.0 | 1.0 | .0  | .0  |
| 187.0 | 21.0 | 5.0  | 1.0 | 3.0 | .0  | .0  | .0  |
| 182.0 | 20.0 | 7.0  | 2.0 | .0  | .0  | .0  | .0  |
| 198.0 | 33.0 | 8.0  | 3.0 | 1.0 | 1.0 | .0  | .0  |
| 156.0 | 30.0 | 3.0  | .0  | .0  | .0  | .0  | .0  |
| 196.0 | 30.0 | 5.0  | 3.0 | .0  | .0  | .0  | .0  |
| 180.0 | 20.0 | 6.0  | 2.0 | 1.0 | .0  | .0  | .0  |
| 172.0 | 28.0 | 10.0 | 1.0 | .0  | 1.0 | .0  | .0  |
| 188.0 | 38.0 | 6.0  | 2.0 | .0  | .0  | .0  | .0  |
| 194.0 | 22.0 | 4.0  | 1.0 | .0  | .0  | .0  | .0  |
| 192.0 | 34.0 | 5.0  | 4.0 | 2.0 | .0  | 1.0 | .0  |
| 183.0 | 24.0 | 9.0  | 2.0 | 2.0 | 1.0 | .0  | 1.0 |
| 203.0 | 22.0 | 5.0  | 3.0 | 3.0 | 1.0 | 1.0 | .0  |
| 208.0 | 34.0 | 4.0  | 1.0 | 1.0 | .0  | 1.0 | .0  |
| 204.0 | 22.0 | 8.0  | 1.0 | 2.0 | .0  | .0  | .0  |
| 222.0 | 27.0 | 8.0  | 3.0 | 1.0 | .0  | 1.0 | .0  |
| 177.0 | 18.0 | 2.0  | 2.0 | 1.0 | 1.0 | 1.0 | .0  |
| 206.0 | 25.0 | 6.0  | 6.0 | 1.0 | 1.0 | .0  | .0  |
| 192.0 | 25.0 | 5.0  | .0  | .0  | 2.0 | .0  | .0  |
| 201.0 | 21.0 | 12.0 | 1.0 | 1.0 | 1.0 | .0  | .0  |
| 211.0 | 30.0 | 6.0  | 2.0 | 1.0 | .0  | .0  | .0  |
| 182.0 | 22.0 | 4.0  | 2.0 | 1.0 | .0  | .0  | .0  |
| 163.0 | 24.0 | 8.0  | 3.0 | .0  | .0  | .0  | .0  |
| 180.0 | 47.0 | 11.0 | 3.0 | 1.0 | .0  | .0  | .0  |
| 180.0 | 30.0 | 10.0 | 1.0 | .0  | .0  | .0  | .0  |

0      LOCATION: 12      NOZZLE PRESSURE: 2.5  
 F SETTING: 1.5      HOOD OPENING: 3.0  
 SAMPLE TIME: 300.

|       |      |      |      |     |     |     |     |
|-------|------|------|------|-----|-----|-----|-----|
| 217.0 | 39.0 | 10.0 | 8.0  | .0  | 3.0 | .0  | 3.0 |
| 244.0 | 33.0 | 9.0  | 7.0  | 3.0 | 2.0 | .0  | .0  |
| 245.0 | 33.0 | 11.0 | 6.0  | .0  | 1.0 | .0  | .0  |
| 215.0 | 37.0 | 14.0 | 3.0  | 2.0 | .0  | .0  | .0  |
| 234.0 | 38.0 | 6.0  | 2.0  | 1.0 | .0  | .0  | .0  |
| 220.0 | 31.0 | 14.0 | .0   | 1.0 | 1.0 | .0  | 1.0 |
| 267.0 | 36.0 | 12.0 | 2.0  | 2.0 | 1.0 | .0  | .0  |
| 214.0 | 29.0 | 8.0  | 3.0  | 2.0 | .0  | .0  | .0  |
| 236.0 | 37.0 | 14.0 | 6.0  | 1.0 | 1.0 | .0  | .0  |
| 232.0 | 23.0 | 12.0 | 1.0  | .0  | .0  | .0  | .0  |
| 223.0 | 30.0 | 6.0  | 1.0  | 2.0 | .0  | 1.0 | .0  |
| 212.0 | 35.0 | 13.0 | 6.0  | .0  | 1.0 | .0  | 2.0 |
| 239.0 | 39.0 | 13.0 | 10.0 | .0  | .0  | .0  | .0  |
| 242.0 | 33.0 | 9.0  | 6.0  | 1.0 | .0  | 1.0 | 1.0 |
| 190.0 | 33.0 | 8.0  | 7.0  | 1.0 | 1.0 | .0  | .0  |
| 225.0 | 26.0 | 4.0  | 4.0  | 3.0 | .0  | .0  | .0  |
| 239.0 | 43.0 | 10.0 | 8.0  | 1.0 | .0  | .0  | 1.0 |
| 261.0 | 39.0 | 10.0 | 3.0  | 1.0 | .0  | 2.0 | .0  |
| 250.0 | 35.0 | 10.0 | 3.0  | 2.0 | 1.0 | .0  | .0  |
| 256.0 | 36.0 | 7.0  | 8.0  | 2.0 | .0  | 2.0 | .0  |
| 229.0 | 40.0 | 10.0 | 3.0  | 1.0 | 1.0 | 1.0 | .0  |
| 216.0 | 37.0 | 13.0 | 4.0  | 1.0 | .0  | .0  | .0  |
| 220.0 | 43.0 | 9.0  | 4.0  | 2.0 | 1.0 | 1.0 | 1.0 |

|       |      |     |     |     |     |     |     |
|-------|------|-----|-----|-----|-----|-----|-----|
| 212.0 | 27.0 | 9.0 | 6.0 | 3.0 | 1.0 | 1.0 | 1.0 |
| 211.0 | 26.0 | 8.0 | 1.0 | .0  | 1.0 | .0  | .0  |

0 LOCATION: 1 NOZZLE PRESSURE: 2.5  
 F SETTING: 1.5 HOOD OPENING: 3.0  
 SAMPLE TIME: 300.

|       |       |      |      |      |     |     |     |
|-------|-------|------|------|------|-----|-----|-----|
| 493.0 | 84.0  | 23.0 | 11.0 | 8.0  | 3.0 | 2.0 | 2.0 |
| 537.0 | 90.0  | 17.0 | 16.0 | 5.0  | 4.0 | .0  | 1.0 |
| 478.0 | 72.0  | 26.0 | 17.0 | 11.0 | 2.0 | 3.0 | .0  |
| 529.0 | 88.0  | 28.0 | 6.0  | 4.0  | 9.0 | 3.0 | 1.0 |
| 575.0 | 88.0  | 27.0 | 13.0 | 8.0  | 2.0 | 1.0 | .0  |
| 544.0 | 96.0  | 27.0 | 14.0 | 5.0  | 6.0 | 1.0 | 1.0 |
| 489.0 | 83.0  | 27.0 | 12.0 | 3.0  | 4.0 | 1.0 | 1.0 |
| 527.0 | 97.0  | 30.0 | 15.0 | 7.0  | 3.0 | .0  | 1.0 |
| 517.0 | 98.0  | 22.0 | 23.0 | 6.0  | 3.0 | .0  | 1.0 |
| 453.0 | 63.0  | 34.0 | 9.0  | 12.0 | 2.0 | .0  | .0  |
| 484.0 | 101.0 | 30.0 | 15.0 | 4.0  | 6.0 | .0  | 2.0 |
| 511.0 | 77.0  | 26.0 | 9.0  | 7.0  | 3.0 | 4.0 | 2.0 |
| 530.0 | 83.0  | 33.0 | 13.0 | 8.0  | 5.0 | 1.0 | 1.0 |
| 519.0 | 95.0  | 33.0 | 10.0 | 4.0  | .0  | 1.0 | .0  |
| 500.0 | 84.0  | 34.0 | 13.0 | 8.0  | 4.0 | 1.0 | 1.0 |
| 514.0 | 86.0  | 24.0 | 11.0 | 6.0  | 2.0 | 1.0 | 1.0 |
| 592.0 | 72.0  | 26.0 | 14.0 | 7.0  | 3.0 | 1.0 | .0  |
| 486.0 | 59.0  | 26.0 | 11.0 | 11.0 | 2.0 | 1.0 | 1.0 |
| 495.0 | 92.0  | 24.0 | 11.0 | 11.0 | 1.0 | 1.0 | .0  |
| 563.0 | 87.0  | 25.0 | 12.0 | 8.0  | 3.0 | .0  | .0  |
| 467.0 | 87.0  | 30.0 | 16.0 | 5.0  | 2.0 | 1.0 | 1.0 |
| 506.0 | 87.0  | 36.0 | 18.0 | 7.0  | 3.0 | 2.0 | 1.0 |
| 569.0 | 94.0  | 33.0 | 11.0 | 9.0  | .0  | .0  | .0  |
| 505.0 | 69.0  | 27.0 | 10.0 | 7.0  | 3.0 | 3.0 | 2.0 |
| 484.0 | 99.0  | 31.0 | 11.0 | 8.0  | 2.0 | .0  | .0  |
| 569.0 | 105.0 | 31.0 | 9.0  | 3.0  | 6.0 | 2.0 | .0  |
| 495.0 | 78.0  | 20.0 | 17.0 | 5.0  | 5.0 | 1.0 | .0  |

0 LOCATION: 28 NOZZLE PRESSURE: 2.5  
 F SETTING: 1.5 HOOD OPENING: 3.0  
 SAMPLE TIME: 300.

|       |      |      |      |      |     |     |     |
|-------|------|------|------|------|-----|-----|-----|
| 392.0 | 69.0 | 16.0 | 14.0 | 6.0  | 1.0 | .0  | 1.0 |
| 375.0 | 49.0 | 10.0 | 11.0 | 1.0  | 3.0 | 2.0 | .0  |
| 360.0 | 53.0 | 18.0 | 13.0 | 4.0  | .0  | 1.0 | 1.0 |
| 349.0 | 74.0 | 19.0 | 5.0  | 2.0  | 2.0 | 1.0 | .0  |
| 344.0 | 53.0 | 15.0 | 7.0  | 5.0  | 1.0 | 2.0 | 1.0 |
| 427.0 | 90.0 | 17.0 | 8.0  | 4.0  | 4.0 | .0  | .0  |
| 385.0 | 57.0 | 25.0 | 11.0 | 5.0  | 2.0 | .0  | .0  |
| 345.0 | 51.0 | 23.0 | 12.0 | 2.0  | 1.0 | 1.0 | .0  |
| 329.0 | 59.0 | 22.0 | 14.0 | 4.0  | 6.0 | .0  | .0  |
| 351.0 | 78.0 | 22.0 | 7.0  | 6.0  | 3.0 | .0  | .0  |
| 382.0 | 68.0 | 32.0 | 17.0 | 8.0  | .0  | 2.0 | 1.0 |
| 396.0 | 51.0 | 14.0 | 12.0 | 3.0  | .0  | .0  | .0  |
| 341.0 | 57.0 | 29.0 | 9.0  | 3.0  | 7.0 | 3.0 | .0  |
| 337.0 | 67.0 | 25.0 | 10.0 | 4.0  | 3.0 | 1.0 | 1.0 |
| 371.0 | 55.0 | 24.0 | 11.0 | 10.0 | 1.0 | 1.0 | .0  |
| 382.0 | 65.0 | 19.0 | 13.0 | 7.0  | 1.0 | 1.0 | .0  |
| 353.0 | 57.0 | 17.0 | 6.0  | 4.0  | 2.0 | 2.0 | .0  |
| 387.0 | 56.0 | 27.0 | 7.0  | 7.0  | 1.0 | 1.0 | .0  |

|       |      |      |      |     |     |     |     |
|-------|------|------|------|-----|-----|-----|-----|
| 391.0 | 58.0 | 31.0 | 9.0  | 2.0 | 3.0 | .0  | .0  |
| 349.0 | 79.0 | 19.0 | 10.0 | 5.0 | 2.0 | 1.0 | 1.0 |
| 372.0 | 53.0 | 18.0 | 13.0 | 2.0 | 2.0 | 2.0 | 1.0 |
| 308.0 | 72.0 | 14.0 | 9.0  | 5.0 | 2.0 | .0  | .0  |
| 344.0 | 48.0 | 17.0 | 9.0  | 4.0 | 5.0 | .0  | 1.0 |
| 423.0 | 67.0 | 29.0 | 12.0 | 4.0 | 2.0 | .0  | 1.0 |
| 349.0 | 63.0 | 14.0 | 6.0  | 5.0 | .0  | 1.0 | 1.0 |
| 320.0 | 42.0 | 21.0 | 10.0 | 2.0 | 2.0 | .0  | .0  |
| 395.0 | 63.0 | 16.0 | 7.0  | 6.0 | 3.0 | 1.0 | 1.0 |
| 386.0 | 61.0 | 10.0 | 10.0 | 4.0 | .0  | .0  | .0  |

0 LOCATION: 55 NOZZLE PRESSURE: 2.5  
 F SETTING: 1.5 HOOD OPENING: 3.0  
 SAMPLE TIME: 300.

|       |      |      |     |     |     |     |    |
|-------|------|------|-----|-----|-----|-----|----|
| 105.0 | 12.0 | 5.0  | 2.0 | .0  | 1.0 | .0  | .0 |
| 119.0 | 25.0 | 4.0  | 1.0 | .0  | .0  | .0  | .0 |
| 113.0 | 25.0 | 6.0  | 1.0 | 2.0 | .0  | .0  | .0 |
| 117.0 | 20.0 | 5.0  | 1.0 | .0  | 1.0 | .0  | .0 |
| 96.0  | 22.0 | 6.0  | 3.0 | 1.0 | .0  | .0  | .0 |
| 127.0 | 26.0 | 12.0 | .0  | 1.0 | .0  | .0  | .0 |
| 105.0 | 25.0 | 7.0  | 6.0 | 2.0 | .0  | .0  | .0 |
| 133.0 | 22.0 | 8.0  | 3.0 | .0  | .0  | 1.0 | .0 |
| 126.0 | 19.0 | 5.0  | 2.0 | .0  | .0  | .0  | .0 |
| 133.0 | 21.0 | 1.0  | 4.0 | 1.0 | .0  | .0  | .0 |
| 142.0 | 21.0 | 8.0  | 1.0 | .0  | 1.0 | .0  | .0 |
| 114.0 | 14.0 | 3.0  | 5.0 | 1.0 | .0  | .0  | .0 |
| 119.0 | 18.0 | 15.0 | 1.0 | 1.0 | .0  | .0  | .0 |
| 128.0 | 22.0 | 11.0 | 2.0 | 1.0 | .0  | .0  | .0 |
| 124.0 | 26.0 | 6.0  | 4.0 | .0  | .0  | .0  | .0 |
| 110.0 | 25.0 | 1.0  | 4.0 | .0  | .0  | .0  | .0 |
| 117.0 | 15.0 | 8.0  | .0  | 1.0 | 1.0 | .0  | .0 |
| 130.0 | 19.0 | 7.0  | 2.0 | 1.0 | .0  | 1.0 | .0 |
| 136.0 | 31.0 | 6.0  | 5.0 | .0  | .0  | .0  | .0 |
| 122.0 | 28.0 | 4.0  | 1.0 | .0  | .0  | .0  | .0 |
| 128.0 | 16.0 | 6.0  | 1.0 | 1.0 | .0  | .0  | .0 |
| 156.0 | 17.0 | 7.0  | 3.0 | .0  | 1.0 | .0  | .0 |
| 121.0 | 19.0 | 12.0 | 1.0 | 2.0 | .0  | .0  | .0 |
| 117.0 | 28.0 | 7.0  | 4.0 | .0  | .0  | .0  | .0 |
| 119.0 | 28.0 | 10.0 | 3.0 | 1.0 | .0  | .0  | .0 |

0 LOCATION: 73 NOZZLE PRESSURE: 2.5  
 F SETTING: 1.5 HOOD OPENING: 3.0  
 SAMPLE TIME: 300.

|       |      |      |     |     |     |     |    |
|-------|------|------|-----|-----|-----|-----|----|
| 166.0 | 21.0 | 4.0  | 4.0 | 3.0 | .0  | .0  | .0 |
| 129.0 | 19.0 | 6.0  | 2.0 | 1.0 | .0  | .0  | .0 |
| 173.0 | 19.0 | 4.0  | 4.0 | .0  | .0  | .0  | .0 |
| 203.0 | 26.0 | 13.0 | 3.0 | 2.0 | .0  | .0  | .0 |
| 144.0 | 21.0 | 6.0  | .0  | .0  | 1.0 | .0  | .0 |
| 154.0 | 23.0 | 6.0  | 4.0 | .0  | .0  | .0  | .0 |
| 156.0 | 32.0 | 15.0 | 2.0 | .0  | .0  | .0  | .0 |
| 183.0 | 25.0 | 8.0  | 5.0 | .0  | .0  | .0  | .0 |
| 150.0 | 23.0 | 7.0  | 2.0 | .0  | 1.0 | 1.0 | .0 |
| 163.0 | 21.0 | 8.0  | 5.0 | .0  | .0  | .0  | .0 |
| 190.0 | 31.0 | 6.0  | 5.0 | .0  | .0  | .0  | .0 |
| 151.0 | 22.0 | 5.0  | 3.0 | .0  | .0  | .0  | .0 |

|       |      |      |     |     |     |     |     |
|-------|------|------|-----|-----|-----|-----|-----|
| 132.0 | 38.0 | 17.0 | 3.0 | 1.0 | .0  | .0  | .0  |
| 139.0 | 20.0 | 5.0  | 5.0 | .0  | .0  | .0  | .0  |
| 169.0 | 31.0 | 10.0 | 7.0 | 2.0 | .0  | .0  | .0  |
| 181.0 | 24.0 | 6.0  | 6.0 | .0  | .0  | .0  | .0  |
| 151.0 | 26.0 | 11.0 | 4.0 | 1.0 | .0  | .0  | .0  |
| 171.0 | 20.0 | 7.0  | 2.0 | 1.0 | .0  | .0  | .0  |
| 173.0 | 21.0 | 13.0 | 6.0 | .0  | .0  | .0  | .0  |
| 179.0 | 28.0 | 7.0  | 1.0 | .0  | .0  | .0  | .0  |
| 175.0 | 22.0 | 8.0  | 3.0 | .0  | .0  | .0  | .0  |
| 181.0 | 26.0 | 10.0 | 5.0 | 2.0 | .0  | .0  | .0  |
| 153.0 | 19.0 | 13.0 | 3.0 | 1.0 | .0  | .0  | 1.0 |
| 161.0 | 24.0 | 9.0  | 4.0 | 1.0 | .0  | 1.0 | .0  |
| 149.0 | 32.0 | 6.0  | 4.0 | .0  | .0  | 1.0 | .0  |
| 188.0 | 31.0 | 11.0 | 2.0 | 1.0 | 1.0 | .0  | .0  |
| 168.0 | 33.0 | 7.0  | 1.0 | 1.0 | 1.0 | .0  | .0  |

0 LOCATION: 64 NOZZLE PRESSURE: 2.5  
 F SETTING: 1.5 HOOD OPENING: 3.0  
 SAMPLE TIME: 300.

|       |      |      |      |     |     |     |     |
|-------|------|------|------|-----|-----|-----|-----|
| 274.0 | 28.0 | 20.0 | 5.0  | .0  | .0  | .0  | .0  |
| 244.0 | 50.0 | 13.0 | 5.0  | 4.0 | 2.0 | .0  | 1.0 |
| 261.0 | 49.0 | 11.0 | 11.0 | 4.0 | 2.0 | 1.0 | .0  |
| 266.0 | 44.0 | 15.0 | 11.0 | .0  | .0  | 1.0 | .0  |
| 279.0 | 40.0 | 16.0 | 7.0  | 1.0 | 1.0 | .0  | .0  |
| 304.0 | 41.0 | 21.0 | 6.0  | 2.0 | .0  | .0  | .0  |
| 241.0 | 54.0 | 16.0 | 6.0  | 3.0 | 1.0 | .0  | 1.0 |
| 242.0 | 31.0 | 12.0 | 6.0  | 3.0 | .0  | .0  | .0  |
| 305.0 | 50.0 | 13.0 | 10.0 | 1.0 | 1.0 | 1.0 | 1.0 |
| 222.0 | 35.0 | 13.0 | 5.0  | .0  | .0  | .0  | .0  |
| 264.0 | 57.0 | 14.0 | 4.0  | 4.0 | .0  | .0  | .0  |
| 246.0 | 51.0 | 16.0 | 7.0  | 3.0 | 1.0 | 1.0 | .0  |
| 331.0 | 49.0 | 18.0 | 4.0  | 2.0 | 2.0 | .0  | 1.0 |
| 270.0 | 42.0 | 10.0 | 6.0  | 4.0 | 4.0 | .0  | .0  |
| 273.0 | 35.0 | 11.0 | 4.0  | 3.0 | 2.0 | 1.0 | .0  |
| 348.0 | 55.0 | 19.0 | 7.0  | 1.0 | 2.0 | 1.0 | 1.0 |
| 279.0 | 33.0 | 21.0 | 3.0  | 3.0 | 1.0 | .0  | .0  |
| 280.0 | 41.0 | 20.0 | 7.0  | 3.0 | 1.0 | .0  | .0  |
| 283.0 | 53.0 | 19.0 | 5.0  | 2.0 | 1.0 | 2.0 | .0  |
| 284.0 | 35.0 | 11.0 | 6.0  | 1.0 | .0  | .0  | .0  |
| 280.0 | 52.0 | 17.0 | 8.0  | 2.0 | 1.0 | .0  | .0  |
| 323.0 | 37.0 | 15.0 | 7.0  | 6.0 | .0  | .0  | .0  |
| 305.0 | 49.0 | 17.0 | 5.0  | 2.0 | 1.0 | .0  | 1.0 |
| 259.0 | 42.0 | 14.0 | 5.0  | 2.0 | 1.0 | .0  | .0  |
| 291.0 | 40.0 | 16.0 | 6.0  | 4.0 | .0  | 1.0 | .0  |
| 275.0 | 38.0 | 26.0 | 4.0  | 3.0 | .0  | .0  | .0  |

0 LOCATION: 27 NOZZLE PRESSURE: 2.5  
 F SETTING: 1.5 HOOD OPENING: 3.0  
 SAMPLE TIME: 300.

|       |      |      |      |     |     |     |     |
|-------|------|------|------|-----|-----|-----|-----|
| 283.0 | 54.0 | 21.0 | 10.0 | 3.0 | 1.0 | 1.0 | 1.0 |
| 268.0 | 54.0 | 22.0 | 7.0  | 7.0 | 3.0 | 2.0 | .0  |
| 276.0 | 67.0 | 23.0 | 22.0 | 6.0 | 1.0 | 5.0 | .0  |
| 263.0 | 42.0 | 16.0 | 16.0 | 2.0 | 2.0 | .0  | .0  |
| 265.0 | 49.0 | 20.0 | 5.0  | 3.0 | 1.0 | 1.0 | 3.0 |
| 271.0 | 56.0 | 15.0 | 6.0  | 2.0 | 6.0 | 1.0 | 2.0 |



|       |      |      |      |      |     |     |     |
|-------|------|------|------|------|-----|-----|-----|
| 310.0 | 50.0 | 27.0 | 9.0  | 3.0  | 3.0 | .0  | .0  |
| 201.0 | 43.0 | 14.0 | 11.0 | 4.0  | 1.0 | 2.0 | .0  |
| 286.0 | 63.0 | 19.0 | 12.0 | 4.0  | 2.0 | .0  | 1.0 |
| 291.0 | 52.0 | 23.0 | 10.0 | 3.0  | 1.0 | 1.0 | .0  |
| 277.0 | 53.0 | 19.0 | 14.0 | 11.0 | 1.0 | 1.0 | .0  |
| 259.0 | 45.0 | 17.0 | 6.0  | 7.0  | 1.0 | 1.0 | 1.0 |
| 291.0 | 57.0 | 18.0 | 5.0  | 4.0  | 1.0 | 1.0 | 1.0 |
| 318.0 | 69.0 | 19.0 | 4.0  | 3.0  | 2.0 | 2.0 | 2.0 |
| 256.0 | 59.0 | 23.0 | 14.0 | 2.0  | 1.0 | 3.0 | .0  |
| 297.0 | 55.0 | 20.0 | 9.0  | .0   | 2.0 | .0  | .0  |
| 231.0 | 57.0 | 21.0 | 9.0  | 6.0  | 1.0 | 2.0 | 2.0 |
| 271.0 | 50.0 | 26.0 | 8.0  | 5.0  | .0  | .0  | .0  |
| 274.0 | 42.0 | 15.0 | 6.0  | 4.0  | 2.0 | .0  | .0  |
| 279.0 | 50.0 | 27.0 | 9.0  | 6.0  | 1.0 | 1.0 | .0  |
| 253.0 | 57.0 | 20.0 | 7.0  | 4.0  | 1.0 | .0  | .0  |
| 223.0 | 49.0 | 11.0 | 8.0  | 3.0  | 3.0 | 2.0 | .0  |
| 276.0 | 61.0 | 21.0 | 8.0  | 2.0  | 4.0 | 1.0 | .0  |
| 252.0 | 48.0 | 21.0 | 8.0  | 4.0  | 6.0 | .0  | .0  |
| 263.0 | 49.0 | 13.0 | 10.0 | 6.0  | 2.0 | 1.0 | .0  |
| 180.0 | 48.0 | 18.0 | 10.0 | 2.0  | 2.0 | .0  | .0  |

0 LOCATION: 81 NOZZLE PRESSURE: 2.5  
 F SETTING: 1.5 HOOD OPENING: 3.0  
 SAMPLE TIME: 300.

|       |      |      |      |     |     |     |     |
|-------|------|------|------|-----|-----|-----|-----|
| 115.0 | 54.0 | 13.0 | 6.0  | 5.0 | .0  | .0  | .0  |
| 94.0  | 14.0 | 8.0  | 10.0 | 2.0 | .0  | .0  | .0  |
| 147.0 | 51.0 | 7.0  | 7.0  | 3.0 | .0  | .0  | .0  |
| 94.0  | 23.0 | 9.0  | 5.0  | 3.0 | 2.0 | .0  | .0  |
| 132.0 | 34.0 | 9.0  | 5.0  | 2.0 | 1.0 | .0  | .0  |
| 129.0 | 27.0 | 3.0  | 5.0  | 2.0 | .0  | 1.0 | .0  |
| 117.0 | 19.0 | 17.0 | 3.0  | 4.0 | .0  | .0  | .0  |
| 104.0 | 15.0 | 8.0  | 4.0  | .0  | .0  | 1.0 | .0  |
| 97.0  | 26.0 | 8.0  | 8.0  | 1.0 | 1.0 | .0  | .0  |
| 102.0 | 25.0 | 7.0  | 8.0  | 2.0 | 2.0 | .0  | .0  |
| 101.0 | 22.0 | 6.0  | 5.0  | 2.0 | .0  | .0  | .0  |
| 106.0 | 24.0 | 9.0  | .0   | .0  | .0  | .0  | .0  |
| 94.0  | 22.0 | 12.0 | .0   | 1.0 | .0  | .0  | .0  |
| 95.0  | 32.0 | 14.0 | 3.0  | 4.0 | 1.0 | .0  | 1.0 |
| 91.0  | 18.0 | 5.0  | 8.0  | .0  | .0  | .0  | .0  |
| 111.0 | 24.0 | 15.0 | 4.0  | 2.0 | .0  | .0  | .0  |
| 100.0 | 27.0 | 12.0 | 6.0  | .0  | .0  | 2.0 | .0  |
| 127.0 | 19.0 | 12.0 | 1.0  | 2.0 | .0  | .0  | .0  |
| 99.0  | 19.0 | 5.0  | 4.0  | 3.0 | 1.0 | .0  | .0  |
| 135.0 | 27.0 | 4.0  | 5.0  | 1.0 | 1.0 | .0  | .0  |
| 133.0 | 29.0 | 10.0 | 4.0  | .0  | .0  | .0  | .0  |

0 LOCATION: 72 NOZZLE PRESSURE: 2.5  
 F SETTING: 1.5 HOOD OPENING: 3.0  
 SAMPLE TIME: 300.

|       |      |      |     |     |     |     |    |
|-------|------|------|-----|-----|-----|-----|----|
| 108.0 | 20.0 | 11.0 | 4.0 | 1.0 | .0  | 1.0 | .0 |
| 93.0  | 25.0 | 8.0  | 1.0 | 1.0 | .0  | .0  | .0 |
| 112.0 | 27.0 | 12.0 | 4.0 | 1.0 | 1.0 | .0  | .0 |
| 87.0  | 24.0 | 9.0  | 2.0 | 1.0 | .0  | .0  | .0 |
| 101.0 | 14.0 | 12.0 | 3.0 | 1.0 | .0  | .0  | .0 |
| 76.0  | 17.0 | 4.0  | 5.0 | .0  | .0  | .0  | .0 |

|       |      |      |     |     |     |    |     |
|-------|------|------|-----|-----|-----|----|-----|
| 84.0  | 25.0 | 6.0  | 3.0 | .0  | .0  | .0 | .0  |
| 97.0  | 26.0 | 14.0 | 2.0 | 2.0 | .0  | .0 | .0  |
| 117.0 | 21.0 | 7.0  | 4.0 | .0  | 3.0 | .0 | 1.0 |
| 63.0  | 15.0 | 8.0  | .0  | 2.0 | 1.0 | .0 | .0  |
| 93.0  | 16.0 | 5.0  | 4.0 | .0  | .0  | .0 | .0  |
| 87.0  | 20.0 | 7.0  | 3.0 | .0  | .0  | .0 | .0  |
| 81.0  | 20.0 | 5.0  | 5.0 | 1.0 | 1.0 | .0 | .0  |
| 60.0  | 20.0 | 5.0  | 1.0 | 1.0 | .0  | .0 | .0  |
| 88.0  | 13.0 | 12.0 | 4.0 | .0  | 1.0 | .0 | .0  |
| 86.0  | 14.0 | 9.0  | 3.0 | .0  | .0  | .0 | .0  |
| 103.0 | 24.0 | 10.0 | 4.0 | .0  | .0  | .0 | .0  |
| 105.0 | 17.0 | 5.0  | 6.0 | 1.0 | .0  | .0 | .0  |
| 83.0  | 24.0 | 5.0  | 4.0 | .0  | .0  | .0 | .0  |
| 90.0  | 18.0 | 6.0  | 2.0 | .0  | .0  | .0 | .0  |
| 81.0  | 12.0 | 10.0 | 1.0 | 1.0 | .0  | .0 | .0  |

0 LOCATION: 9 NOZZLE PRESSURE: 2.5  
 F SETTING: 1.5 HOOD OPENING: 3.0  
 SAMPLE TIME: 300.

|       |      |      |      |     |     |     |     |
|-------|------|------|------|-----|-----|-----|-----|
| 143.0 | 37.0 | 13.0 | 6.0  | .0  | 1.0 | .0  | .0  |
| 132.0 | 25.0 | 12.0 | 7.0  | 2.0 | 1.0 | 1.0 | .0  |
| 133.0 | 14.0 | 15.0 | 6.0  | 3.0 | .0  | .0  | .0  |
| 132.0 | 17.0 | 16.0 | 6.0  | 1.0 | .0  | .0  | .0  |
| 138.0 | 33.0 | 16.0 | 13.0 | 2.0 | .0  | .0  | 1.0 |
| 95.0  | 21.0 | 12.0 | 10.0 | 3.0 | .0  | .0  | .0  |
| 146.0 | 28.0 | 17.0 | 7.0  | 3.0 | 3.0 | 1.0 | .0  |
| 105.0 | 28.0 | 15.0 | 7.0  | .0  | .0  | 1.0 | .0  |
| 127.0 | 32.0 | 17.0 | 5.0  | 1.0 | 2.0 | 1.0 | .0  |
| 136.0 | 21.0 | 8.0  | 15.0 | 4.0 | 1.0 | 1.0 | .0  |
| 137.0 | 27.0 | 23.0 | 6.0  | 2.0 | 2.0 | .0  | .0  |
| 115.0 | 29.0 | 16.0 | 9.0  | 2.0 | .0  | .0  | 1.0 |
| 136.0 | 29.0 | 6.0  | 9.0  | 2.0 | 1.0 | .0  | 1.0 |
| 107.0 | 26.0 | 10.0 | 8.0  | 3.0 | 1.0 | .0  | .0  |
| 115.0 | 25.0 | 16.0 | 8.0  | 3.0 | .0  | 1.0 | .0  |
| 101.0 | 60.0 | 50.0 | 4.0  | 4.0 | .0  | 1.0 | .0  |
| 130.0 | 44.0 | 69.0 | 15.0 | 4.0 | .0  | .0  | .0  |
| 98.0  | 60.0 | 47.0 | 2.0  | 2.0 | 2.0 | .0  | .0  |
| 110.0 | 53.0 | 58.0 | 4.0  | 6.0 | 2.0 | 1.0 | .0  |
| 119.0 | 60.0 | 59.0 | 7.0  | 2.0 | 2.0 | .0  | .0  |
| 104.0 | 54.0 | 55.0 | 4.0  | 4.0 | .0  | .0  | 1.0 |
| 143.0 | 61.0 | 60.0 | 1.0  | 1.0 | .0  | .0  | 1.0 |
| 155.0 | 75.0 | 43.0 | 9.0  | 9.0 | .0  | 1.0 | .0  |
| 152.0 | 79.0 | 22.0 | 11.0 | 3.0 | 2.0 | .0  | .0  |
| 149.0 | 78.0 | 20.0 | 6.0  | 1.0 | 1.0 | .0  | .0  |
| 154.0 | 62.0 | 18.0 | 4.0  | 3.0 | .0  | .0  | .0  |
| 142.0 | 53.0 | 10.0 | 5.0  | 2.0 | .0  | .0  | .0  |

0 LOCATION: 21 NOZZLE PRESSURE: 2.5  
 F SETTING: 1.5 HOOD OPENING: 3.0  
 SAMPLE TIME: 300.

|       |      |      |      |      |     |     |     |
|-------|------|------|------|------|-----|-----|-----|
| 277.0 | 55.0 | 24.0 | 9.0  | 7.0  | 2.0 | 1.0 | 1.0 |
| 333.0 | 84.0 | 36.0 | 22.0 | 7.0  | 5.0 | 5.0 | .0  |
| 366.0 | 78.0 | 22.0 | 9.0  | 10.0 | 1.0 | .0  | .0  |
| 294.0 | 77.0 | 39.0 | 1.0  | 3.0  | 1.0 | .0  | .0  |
| 294.0 | 79.0 | 24.0 | 9.0  | 8.0  | 5.0 | 1.0 | .0  |

AD-A134 810

PROJECT DELUGE: THE DEVELOPMENT OF A HOLLOMAN HIGH  
SPEED TEST TRACK HEAVY RAINFIELD(U) ARMAMENT DIV (AFSC)  
EGLIN AFB FL J A SHIPE 01 JUN 83 AD-TR-83-42

22

UNCLASSIFIED

F/G 4/2

NL



END  
DATE  
FILMED  
12 JAN  
DTIC

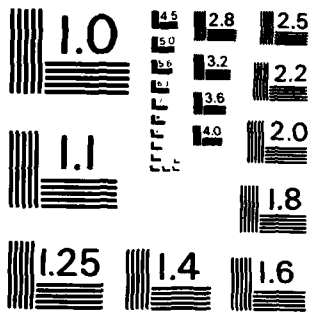

MICROCOPY RESOLUTION TEST CHART  
NATIONAL BUREAU OF STANDARDS - 1963 - A

|       |      |      |      |      |     |     |     |
|-------|------|------|------|------|-----|-----|-----|
| 338.0 | 66.0 | 38.0 | 10.0 | 6.0  | 7.0 | 3.0 | 1.0 |
| 311.0 | 95.0 | 38.0 | 9.0  | 2.0  | 2.0 | 1.0 | .0  |
| 310.0 | 56.0 | 28.0 | 12.0 | 12.0 | 7.0 | 4.0 | 3.0 |
| 368.0 | 84.0 | 25.0 | 12.0 | 7.0  | 3.0 | 1.0 | 2.0 |
| 355.0 | 78.0 | 24.0 | 12.0 | 7.0  | 4.0 | 3.0 | .0  |
| 358.0 | 61.0 | 29.0 | 10.0 | 13.0 | 2.0 | 3.0 | 2.0 |
| 357.0 | 77.0 | 25.0 | 12.0 | 7.0  | 4.0 | 4.0 | .0  |
| 350.0 | 74.0 | 27.0 | 14.0 | 7.0  | 3.0 | 1.0 | .0  |
| 364.0 | 64.0 | 17.0 | 15.0 | 6.0  | 3.0 | .0  | 4.0 |
| 342.0 | 62.0 | 25.0 | 13.0 | 5.0  | 5.0 | 2.0 | .0  |
| 358.0 | 66.0 | 24.0 | 20.0 | 2.0  | 3.0 | 3.0 | 2.0 |
| 314.0 | 67.0 | 24.0 | 23.0 | 5.0  | 6.0 | 2.0 | 2.0 |
| 320.0 | 84.0 | 36.0 | 17.0 | 5.0  | 3.0 | 3.0 | 2.0 |
| 326.0 | 75.0 | 24.0 | 15.0 | 5.0  | 5.0 | .0  | 1.0 |
| 332.0 | 70.0 | 35.0 | 14.0 | 8.0  | 1.0 | 3.0 | .0  |
| 335.0 | 76.0 | 30.0 | 16.0 | 9.0  | 3.0 | 1.0 | 4.0 |
| 308.0 | 66.0 | 17.0 | 12.0 | 3.0  | 6.0 | 4.0 | 2.0 |
| 317.0 | 82.0 | 29.0 | 17.0 | 9.0  | 8.0 | 3.0 | 3.0 |
| 366.0 | 82.0 | 39.0 | 17.0 | 4.0  | 1.0 | 2.0 | 2.0 |

0 LOCATION: 8 NOZZLE PRESSURE: 2.5  
 F SETTING: 1.5 HOOD OPENING: 3.0  
 SAMPLE TIME: 300.

|       |      |      |      |     |     |     |     |
|-------|------|------|------|-----|-----|-----|-----|
| 162.0 | 51.0 | 18.0 | 5.0  | 3.0 | .0  | 2.0 | .0  |
| 160.0 | 52.0 | 18.0 | 9.0  | 3.0 | 2.0 | .0  | 1.0 |
| 174.0 | 52.0 | 20.0 | 11.0 | 3.0 | 1.0 | .0  | .0  |
| 168.0 | 55.0 | 18.0 | 9.0  | 4.0 | 3.0 | .0  | .0  |
| 234.0 | 49.0 | 14.0 | 10.0 | 5.0 | 1.0 | .0  | .0  |
| 279.0 | 44.0 | 22.0 | 11.0 | 5.0 | 2.0 | 1.0 | .0  |
| 253.0 | 34.0 | 12.0 | 13.0 | 4.0 | 1.0 | 1.0 | 1.0 |
| 215.0 | 50.0 | 20.0 | 2.0  | 2.0 | 2.0 | 3.0 | .0  |
| 239.0 | 59.0 | 25.0 | 14.0 | 5.0 | 1.0 | 1.0 | .0  |
| 198.0 | 42.0 | 15.0 | 8.0  | 4.0 | 3.0 | .0  | 1.0 |
| 212.0 | 49.0 | 16.0 | 7.0  | 6.0 | 5.0 | 2.0 | 1.0 |
| 192.0 | 64.0 | 25.0 | 5.0  | 4.0 | 6.0 | 1.0 | 1.0 |
| 226.0 | 78.0 | 22.0 | 11.0 | 6.0 | 2.0 | 1.0 | .0  |
| 163.0 | 41.0 | 21.0 | 6.0  | 3.0 | 3.0 | 1.0 | 2.0 |
| 233.0 | 49.0 | 13.0 | 4.0  | 4.0 | 1.0 | .0  | .0  |
| 167.0 | 29.0 | 21.0 | 8.0  | 1.0 | 4.0 | 2.0 | .0  |
| 157.0 | 44.0 | 11.0 | 16.0 | 7.0 | 2.0 | 2.0 | 1.0 |
| 198.0 | 46.0 | 17.0 | 10.0 | 5.0 | 3.0 | 2.0 | .0  |
| 207.0 | 46.0 | 13.0 | 6.0  | 7.0 | 1.0 | .0  | .0  |
| 199.0 | 45.0 | 19.0 | 13.0 | 2.0 | 3.0 | 1.0 | 1.0 |
| 199.0 | 54.0 | 20.0 | 8.0  | 2.0 | 1.0 | 1.0 | .0  |
| 66.0  | 14.0 | 6.0  | 3.0  | 1.0 | .0  | .0  | .0  |
| 143.0 | 55.0 | 20.0 | 15.0 | 4.0 | .0  | 2.0 | .0  |
| 193.0 | 53.0 | 15.0 | 9.0  | 5.0 | 2.0 | 3.0 | 1.0 |

0 LOCATION: 35 NOZZLE PRESSURE: 2.5  
 F SETTING: 1.5 HOOD OPENING: 3.0  
 SAMPLE TIME: 300.

|       |      |      |      |     |     |     |     |
|-------|------|------|------|-----|-----|-----|-----|
| 178.0 | 42.0 | 20.0 | 7.0  | 6.0 | 1.0 | 2.0 | 2.0 |
| 132.0 | 41.0 | 15.0 | 7.0  | 1.0 | 6.0 | 3.0 | .0  |
| 169.0 | 47.0 | 23.0 | 9.0  | 5.0 | 1.0 | 1.0 | .0  |
| 125.0 | 25.0 | 18.0 | 12.0 | 4.0 | 1.0 | 1.0 | 1.0 |

|       |      |      |      |      |     |     |     |
|-------|------|------|------|------|-----|-----|-----|
| 105.0 | 28.0 | 15.0 | 9.0  | 7.0  | 1.0 | 3.0 | 1.0 |
| 143.0 | 44.0 | 9.0  | 12.0 | 6.0  | .0  | 1.0 | .0  |
| 167.0 | 45.0 | 13.0 | 9.0  | 6.0  | 1.0 | 1.0 | 1.0 |
| 141.0 | 37.0 | 22.0 | 9.0  | 4.0  | 2.0 | .0  | .0  |
| 101.0 | 36.0 | 15.0 | 11.0 | 2.0  | 2.0 | .0  | 1.0 |
| 120.0 | 41.0 | 9.0  | 9.0  | 9.0  | 3.0 | 1.0 | .0  |
| 105.0 | 24.0 | 16.0 | 4.0  | 1.0  | 3.0 | .0  | .0  |
| 137.0 | 35.0 | 13.0 | 7.0  | 8.0  | .0  | .0  | .0  |
| 139.0 | 26.0 | 17.0 | 11.0 | 3.0  | 1.0 | .0  | .0  |
| 138.0 | 38.0 | 14.0 | 7.0  | 3.0  | 1.0 | 1.0 | 1.0 |
| 135.0 | 38.0 | 11.0 | 7.0  | 3.0  | .0  | 1.0 | .0  |
| 153.0 | 38.0 | 8.0  | 9.0  | 5.0  | 5.0 | .0  | 1.0 |
| 119.0 | 29.0 | 18.0 | 5.0  | 10.0 | 5.0 | .0  | .0  |
| 95.0  | 32.0 | 10.0 | 4.0  | 3.0  | 1.0 | 1.0 | 2.0 |
| 132.0 | 25.0 | 26.0 | 8.0  | 3.0  | .0  | .0  | .0  |
| 134.0 | 45.0 | 13.0 | 10.0 | 6.0  | 2.0 | .0  | 1.0 |
| 164.0 | 37.0 | 16.0 | 8.0  | 4.0  | 2.0 | 1.0 | .0  |
| 141.0 | 39.0 | 17.0 | 7.0  | 4.0  | 2.0 | .0  | .0  |
| 133.0 | 42.0 | 10.0 | 9.0  | 2.0  | .0  | .0  | .0  |
| 139.0 | 37.0 | 21.0 | 8.0  | 1.0  | 4.0 | 1.0 | 1.0 |
| 156.0 | 33.0 | 23.0 | 9.0  | 7.0  | 2.0 | .0  | 1.0 |
| 127.0 | 25.0 | 17.0 | 5.0  | 6.0  | 2.0 | .0  | 1.0 |
| 140.0 | 44.0 | 13.0 | 10.0 | 3.0  | 1.0 | 1.0 | .0  |
| 148.0 | 28.0 | 15.0 | 2.0  | 3.0  | 1.0 | 1.0 | 1.0 |

0 LOCATION: 62 NOZZLE PRESSURE: 2.5  
 F SETTING: 1.5 HOOD OPENING: 3.0  
 SAMPLE TIME: 300.

|       |      |      |      |     |     |     |     |
|-------|------|------|------|-----|-----|-----|-----|
| 156.0 | 24.0 | 12.0 | 3.0  | 3.0 | .0  | 1.0 | .0  |
| 134.0 | 41.0 | 14.0 | 10.0 | 2.0 | 1.0 | .0  | 1.0 |
| 120.0 | 36.0 | 17.0 | 2.0  | 4.0 | 2.0 | 1.0 | .0  |
| 120.0 | 30.0 | 15.0 | 9.0  | 4.0 | 1.0 | 1.0 | 1.0 |
| 99.0  | 40.0 | 18.0 | 6.0  | 1.0 | 3.0 | 1.0 | .0  |
| 114.0 | 20.0 | 13.0 | 8.0  | 3.0 | 2.0 | .0  | .0  |
| 118.0 | 29.0 | 13.0 | 4.0  | 3.0 | 1.0 | 2.0 | 1.0 |
| 94.0  | 24.0 | 13.0 | 11.0 | 1.0 | .0  | .0  | .0  |
| 114.0 | 33.0 | 16.0 | 10.0 | 2.0 | 1.0 | .0  | 1.0 |
| 135.0 | 31.0 | 7.0  | 7.0  | 2.0 | 1.0 | 1.0 | .0  |
| 104.0 | 38.0 | 13.0 | 5.0  | 5.0 | 1.0 | .0  | .0  |
| 123.0 | 27.0 | 15.0 | 13.0 | 4.0 | .0  | 1.0 | .0  |
| 112.0 | 19.0 | 16.0 | 1.0  | 2.0 | 2.0 | 1.0 | 1.0 |
| 98.0  | 21.0 | 19.0 | 11.0 | 3.0 | .0  | .0  | 1.0 |
| 112.0 | 29.0 | 9.0  | 7.0  | 3.0 | 3.0 | 3.0 | 1.0 |
| 123.0 | 33.0 | 14.0 | 6.0  | 5.0 | 1.0 | .0  | .0  |
| 124.0 | 41.0 | 10.0 | 8.0  | 4.0 | 1.0 | .0  | .0  |
| 89.0  | 27.0 | 13.0 | 6.0  | 5.0 | 2.0 | .0  | 1.0 |
| 125.0 | 23.0 | 17.0 | 13.0 | 2.0 | 2.0 | .0  | .0  |
| 113.0 | 40.0 | 14.0 | 5.0  | 2.0 | 1.0 | .0  | .0  |
| 124.0 | 33.0 | 11.0 | 14.0 | 1.0 | 4.0 | .0  | .0  |

0 LOCATION: 36 NOZZLE PRESSURE: 2.5  
 F SETTING: 1.5 HOOD OPENING: 3.0  
 SAMPLE TIME: 300.

|      |      |     |     |     |    |     |    |
|------|------|-----|-----|-----|----|-----|----|
| 41.0 | 6.0  | 9.0 | 2.0 | 1.0 | .0 | .0  | .0 |
| 41.0 | 11.0 | 7.0 | 4.0 | 1.0 | .0 | 1.0 | .0 |

|      |      |      |     |     |     |     |    |
|------|------|------|-----|-----|-----|-----|----|
| 46.0 | 10.0 | 6.0  | .0  | .0  | 1.0 | .0  | .0 |
| 57.0 | 7.0  | 7.0  | 3.0 | 1.0 | 1.0 | .0  | .0 |
| 42.0 | 12.0 | 10.0 | 2.0 | 1.0 | .0  | .0  | .0 |
| 41.0 | 5.0  | 3.0  | 4.0 | 2.0 | .0  | 1.0 | .0 |
| 40.0 | 14.0 | 3.0  | 5.0 | 1.0 | .0  | .0  | .0 |
| 69.0 | 19.0 | 7.0  | 7.0 | .0  | .0  | .0  | .0 |
| 56.0 | 10.0 | 5.0  | 6.0 | .0  | 1.0 | .0  | .0 |
| 60.0 | 15.0 | 8.0  | 1.0 | 1.0 | .0  | .0  | .0 |
| 61.0 | 10.0 | 9.0  | 6.0 | .0  | 1.0 | .0  | .0 |
| 41.0 | 7.0  | 7.0  | 5.0 | 2.0 | .0  | .0  | .0 |
| 38.0 | 9.0  | 7.0  | 4.0 | 1.0 | .0  | .0  | .0 |
| 43.0 | 10.0 | 9.0  | 4.0 | 1.0 | .0  | .0  | .0 |
| 42.0 | 7.0  | 1.0  | .0  | .0  | .0  | .0  | .0 |
| 42.0 | 13.0 | 7.0  | 2.0 | .0  | 1.0 | .0  | .0 |
| 31.0 | 7.0  | 3.0  | 5.0 | 1.0 | .0  | .0  | .0 |
| 38.0 | 6.0  | 9.0  | 1.0 | .0  | .0  | .0  | .0 |
| 64.0 | 11.0 | 8.0  | 7.0 | 1.0 | .0  | .0  | .0 |
| 52.0 | 22.0 | 3.0  | 4.0 | .0  | .0  | .0  | .0 |
| 44.0 | 13.0 | 9.0  | 1.0 | 1.0 | .0  | .0  | .0 |
| 60.0 | 9.0  | 14.0 | 3.0 | 1.0 | .0  | .0  | .0 |
| 36.0 | 9.0  | 2.0  | 4.0 | .0  | .0  | .0  | .0 |
| 35.0 | 14.0 | 8.0  | 3.0 | .0  | .0  | .0  | .0 |
| 48.0 | 11.0 | 3.0  | 6.0 | 1.0 | .0  | .0  | .0 |
| 33.0 | 10.0 | 3.0  | 3.0 | .0  | .0  | .0  | .0 |

0 LOCATION: 63 NOZZLE PRESSURE: 2.5  
 F SETTING: 1.5 HOOD OPENING: 3.0  
 SAMPLE TIME: 300.

|      |     |     |     |     |    |    |    |
|------|-----|-----|-----|-----|----|----|----|
| 4.0  | 2.0 | .0  | .0  | .0  | .0 | .0 | .0 |
| 11.0 | 5.0 | 2.0 | .0  | .0  | .0 | .0 | .0 |
| 10.0 | 6.0 | .0  | .0  | .0  | .0 | .0 | .0 |
| 10.0 | 4.0 | 2.0 | 1.0 | .0  | .0 | .0 | .0 |
| 12.0 | 5.0 | 2.0 | .0  | .0  | .0 | .0 | .0 |
| 7.0  | 2.0 | .0  | .0  | .0  | .0 | .0 | .0 |
| 8.0  | 2.0 | .0  | 3.0 | .0  | .0 | .0 | .0 |
| 6.0  | 1.0 | 1.0 | .0  | .0  | .0 | .0 | .0 |
| 4.0  | 1.0 | 2.0 | 1.0 | .0  | .0 | .0 | .0 |
| 11.0 | 2.0 | 2.0 | .0  | .0  | .0 | .0 | .0 |
| 4.0  | 2.0 | 1.0 | 1.0 | .0  | .0 | .0 | .0 |
| 10.0 | 3.0 | .0  | .0  | .0  | .0 | .0 | .0 |
| 13.0 | 5.0 | 1.0 | .0  | .0  | .0 | .0 | .0 |
| 8.0  | 3.0 | .0  | .0  | .0  | .0 | .0 | .0 |
| 15.0 | 2.0 | 3.0 | 1.0 | .0  | .0 | .0 | .0 |
| 12.0 | 1.0 | 4.0 | 1.0 | .0  | .0 | .0 | .0 |
| 16.0 | 3.0 | 5.0 | .0  | .0  | .0 | .0 | .0 |
| 12.0 | 2.0 | 1.0 | .0  | .0  | .0 | .0 | .0 |
| 6.0  | 2.0 | 1.0 | .0  | .0  | .0 | .0 | .0 |
| 9.0  | 3.0 | .0  | .0  | .0  | .0 | .0 | .0 |
| 10.0 | 3.0 | 2.0 | .0  | .0  | .0 | .0 | .0 |
| 8.0  | 4.0 | 1.0 | .0  | .0  | .0 | .0 | .0 |
| 8.0  | .0  | .0  | .0  | 1.0 | .0 | .0 | .0 |
| 5.0  | .0  | .0  | .0  | .0  | .0 | .0 | .0 |
| 11.0 | 5.0 | 1.0 | .0  | .0  | .0 | .0 | .0 |
| 9.0  | 2.0 | 3.0 | 1.0 | .0  | .0 | .0 | .0 |
| 13.0 | 2.0 | 2.0 | .0  | .0  | .0 | .0 | .0 |
| 14.0 | 3.0 | .0  | .0  | .0  | .0 | .0 | .0 |

5.0 5.0 2.0 1.0 .0 .0 .0 .0  
 9.0 5.0 .0 .0 .0 .0 .0 .0  
 0 LOCATION: 44 NOZZLE PRESSURE: 2.5  
 F SETTING: 1.5 HOOD OPENING: 3.0  
 SAMPLE TIME: 300.

|       |      |      |      |      |     |     |     |
|-------|------|------|------|------|-----|-----|-----|
| 263.0 | 41.0 | 20.0 | 10.0 | 4.0  | 2.0 | 3.0 | 1.0 |
| 282.0 | 55.0 | 18.0 | 15.0 | 4.0  | 1.0 | .0  | .0  |
| 256.0 | 38.0 | 30.0 | 12.0 | 3.0  | 4.0 | 1.0 | .0  |
| 264.0 | 67.0 | 20.0 | 18.0 | 5.0  | 2.0 | 1.0 | 1.0 |
| 287.0 | 62.0 | 22.0 | 10.0 | 11.0 | 4.0 | 2.0 | .0  |
| 226.0 | 59.0 | 22.0 | 13.0 | 5.0  | 5.0 | 4.0 | 2.0 |
| 267.0 | 66.0 | 17.0 | 11.0 | 4.0  | 1.0 | .0  | 1.0 |
| 254.0 | 50.0 | 21.0 | 12.0 | 3.0  | 3.0 | 1.0 | .0  |
| 244.0 | 39.0 | 29.0 | 17.0 | 7.0  | 3.0 | 1.0 | .0  |
| 220.0 | 70.0 | 26.0 | 8.0  | 4.0  | 4.0 | 5.0 | 2.0 |
| 277.0 | 58.0 | 25.0 | 10.0 | 10.0 | 2.0 | 2.0 | .0  |
| 316.0 | 50.0 | 23.0 | 10.0 | 10.0 | 5.0 | 1.0 | .0  |
| 313.0 | 56.0 | 22.0 | 12.0 | 12.0 | 4.0 | 2.0 | .0  |
| 276.0 | 53.0 | 14.0 | 8.0  | 2.0  | 2.0 | .0  | .0  |
| 296.0 | 60.0 | 28.0 | 12.0 | 4.0  | 4.0 | 1.0 | 1.0 |
| 289.0 | 62.0 | 23.0 | 10.0 | 4.0  | .0  | 1.0 | .0  |
| 281.0 | 75.0 | 16.0 | 8.0  | 3.0  | 7.0 | 1.0 | 1.0 |
| 246.0 | 61.0 | 23.0 | 9.0  | 4.0  | 1.0 | 1.0 | 1.0 |
| 252.0 | 62.0 | 19.0 | 9.0  | 12.0 | 5.0 | 8.0 | 2.0 |
| 286.0 | 58.0 | 26.0 | 12.0 | 5.0  | 6.0 | 2.0 | 1.0 |
| 305.0 | 52.0 | 25.0 | 8.0  | 5.0  | 4.0 | 1.0 | .0  |
| 289.0 | 56.0 | 21.0 | 13.0 | 6.0  | 4.0 | .0  | .0  |
| 276.0 | 48.0 | 20.0 | 10.0 | 8.0  | 3.0 | 2.0 | 2.0 |
| 290.0 | 57.0 | 18.0 | 10.0 | 2.0  | 3.0 | 3.0 | .0  |
| 318.0 | 54.0 | 21.0 | 6.0  | 5.0  | 1.0 | 3.0 | 2.0 |
| 277.0 | 72.0 | 23.0 | 7.0  | 7.0  | 1.0 | 2.0 | 1.0 |
| 331.0 | 80.0 | 22.0 | 8.0  | 4.0  | 6.0 | 1.0 | 1.0 |
| 303.0 | 69.0 | 24.0 | 8.0  | 6.0  | 4.0 | 1.0 | .0  |
| 317.0 | 60.0 | 26.0 | 10.0 | 7.0  | 5.0 | 3.0 | .0  |
| 244.0 | 55.0 | 23.0 | 11.0 | 1.0  | 2.0 | .0  | 1.0 |

0 LOCATION: 17 NOZZLE PRESSURE: 2.5  
 F SETTING: 1.5 HOOD OPENING: 3.0  
 SAMPLE TIME: 300.

|       |      |      |      |      |     |     |     |
|-------|------|------|------|------|-----|-----|-----|
| 234.0 | 54.0 | 15.0 | 6.0  | 6.0  | 5.0 | .0  | 2.0 |
| 238.0 | 69.0 | 16.0 | 7.0  | 7.0  | 2.0 | 1.0 | .0  |
| 220.0 | 52.0 | 16.0 | 7.0  | 2.0  | 2.0 | .0  | .0  |
| 259.0 | 50.0 | 16.0 | 6.0  | 4.0  | .0  | 2.0 | 1.0 |
| 219.0 | 39.0 | 15.0 | 6.0  | 4.0  | 3.0 | 2.0 | .0  |
| 257.0 | 59.0 | 21.0 | 11.0 | 12.0 | 2.0 | 1.0 | 1.0 |
| 224.0 | 44.0 | 24.0 | 10.0 | 4.0  | 2.0 | 1.0 | .0  |
| 231.0 | 49.0 | 20.0 | 8.0  | 5.0  | 1.0 | 1.0 | 1.0 |
| 231.0 | 54.0 | 22.0 | 9.0  | 5.0  | 3.0 | .0  | .0  |
| 242.0 | 51.0 | 25.0 | 8.0  | 4.0  | 1.0 | 1.0 | .0  |
| 203.0 | 33.0 | 18.0 | 5.0  | 2.0  | 3.0 | 3.0 | .0  |
| 219.0 | 60.0 | 25.0 | 9.0  | 4.0  | 3.0 | 1.0 | .0  |
| 272.0 | 47.0 | 12.0 | 8.0  | 5.0  | 2.0 | 2.0 | .0  |
| 221.0 | 42.0 | 21.0 | 5.0  | 1.0  | 2.0 | 1.0 | .0  |
| 227.0 | 48.0 | 13.0 | 3.0  | 7.0  | 2.0 | 1.0 | .0  |



|       |      |      |      |     |     |     |     |
|-------|------|------|------|-----|-----|-----|-----|
| 222.0 | 45.0 | 17.0 | 8.0  | 2.0 | 2.0 | .0  | .0  |
| 229.0 | 53.0 | 25.0 | 16.0 | 5.0 | 5.0 | 2.0 | .0  |
| 205.0 | 55.0 | 20.0 | 7.0  | 4.0 | 4.0 | .0  | .0  |
| 225.0 | 39.0 | 19.0 | 6.0  | 1.0 | 1.0 | .0  | .0  |
| 219.0 | 42.0 | 17.0 | 8.0  | 5.0 | .0  | 1.0 | .0  |
| 253.0 | 43.0 | 20.0 | 6.0  | 2.0 | 2.0 | 1.0 | 1.0 |
| 232.0 | 52.0 | 21.0 | 7.0  | 7.0 | 1.0 | 2.0 | .0  |
| 263.0 | 57.0 | 17.0 | 11.0 | 2.0 | 2.0 | .0  | .0  |
| 282.0 | 58.0 | 17.0 | 12.0 | 4.0 | 2.0 | .0  | .0  |
| 296.0 | 53.0 | 9.0  | 7.0  | 2.0 | .0  | .0  | 1.0 |
| 214.0 | 55.0 | 19.0 | 9.0  | 1.0 | 3.0 | 1.0 | 2.0 |
| 223.0 | 51.0 | 11.0 | 10.0 | 7.0 | 1.0 | .0  | .0  |
| 230.0 | 47.0 | 19.0 | 7.0  | 3.0 | 2.0 | 1.0 | .0  |

0 LOCATION: 26 NOZZLE PRESSURE: 2.5  
 F SETTING: 1.5 HOOD OPENING: 3.0  
 SAMPLE TIME: 300.

|       |      |      |     |     |     |     |     |
|-------|------|------|-----|-----|-----|-----|-----|
| 252.0 | 42.0 | 14.0 | 9.0 | 3.0 | 1.0 | 2.0 | .0  |
| 266.0 | 45.0 | 14.0 | 8.0 | 1.0 | 2.0 | 1.0 | 3.0 |
| 262.0 | 44.0 | 10.0 | 7.0 | 3.0 | 3.0 | 1.0 | .0  |
| 258.0 | 56.0 | 10.0 | 8.0 | 4.0 | 3.0 | .0  | .0  |
| 284.0 | 51.0 | 10.0 | 6.0 | 4.0 | 1.0 | 1.0 | .0  |
| 288.0 | 41.0 | 20.0 | 6.0 | 2.0 | 2.0 | 1.0 | .0  |
| 288.0 | 49.0 | 19.0 | 7.0 | 1.0 | 1.0 | 1.0 | 2.0 |
| 301.0 | 54.0 | 19.0 | 4.0 | 6.0 | 2.0 | 2.0 | 1.0 |
| 281.0 | 39.0 | 17.0 | 8.0 | 3.0 | 3.0 | 1.0 | .0  |
| 257.0 | 45.0 | 11.0 | 8.0 | 2.0 | .0  | 1.0 | .0  |
| 264.0 | 48.0 | 19.0 | 4.0 | 3.0 | 1.0 | 2.0 | .0  |
| 299.0 | 63.0 | 25.0 | 7.0 | 3.0 | 2.0 | 2.0 | .0  |
| 286.0 | 50.0 | 16.0 | 8.0 | 4.0 | 2.0 | 1.0 | .0  |
| 263.0 | 46.0 | 14.0 | 4.0 | 3.0 | .0  | .0  | 1.0 |
| 237.0 | 38.0 | 20.0 | 9.0 | 3.0 | 2.0 | 1.0 | 1.0 |
| 273.0 | 49.0 | 12.0 | 6.0 | 2.0 | 2.0 | .0  | .0  |
| 265.0 | 49.0 | 18.0 | 6.0 | 2.0 | 2.0 | 1.0 | .0  |
| 268.0 | 44.0 | 14.0 | 7.0 | 3.0 | .0  | .0  | .0  |
| 267.0 | 58.0 | 8.0  | 7.0 | .0  | 1.0 | .0  | .0  |
| 270.0 | 41.0 | 18.0 | 6.0 | .0  | 5.0 | .0  | .0  |
| 265.0 | 42.0 | 14.0 | 5.0 | 2.0 | .0  | 2.0 | .0  |
| 294.0 | 54.0 | 10.0 | 6.0 | 4.0 | 1.0 | .0  | .0  |
| 288.0 | 48.0 | 10.0 | 5.0 | 2.0 | .0  | 2.0 | .0  |
| 258.0 | 47.0 | 27.0 | 6.0 | 2.0 | 3.0 | 2.0 | .0  |

0 LOCATION: 80 NOZZLE PRESSURE: 2.5  
 F SETTING: 1.5 HOOD OPENING: 3.0  
 SAMPLE TIME: 300.

|       |      |      |      |     |     |     |     |
|-------|------|------|------|-----|-----|-----|-----|
| 392.0 | 54.0 | 26.0 | 10.0 | 4.0 | 1.0 | .0  | .0  |
| 408.0 | 77.0 | 31.0 | 12.0 | 9.0 | 1.0 | 3.0 | 1.0 |
| 378.0 | 50.0 | 27.0 | 11.0 | 5.0 | 4.0 | 4.0 | 1.0 |
| 343.0 | 69.0 | 31.0 | 9.0  | 4.0 | 5.0 | 1.0 | .0  |
| 346.0 | 65.0 | 37.0 | 12.0 | 9.0 | 5.0 | 5.0 | .0  |
| 421.0 | 72.0 | 26.0 | 12.0 | 5.0 | 3.0 | 1.0 | .0  |
| 359.0 | 80.0 | 28.0 | 12.0 | 9.0 | 2.0 | 1.0 | 1.0 |
| 328.0 | 78.0 | 38.0 | 19.0 | 7.0 | 3.0 | 3.0 | 1.0 |
| 363.0 | 58.0 | 27.0 | 10.0 | 2.0 | 2.0 | 2.0 | .0  |
| 343.0 | 81.0 | 37.0 | 16.0 | 7.0 | 5.0 | 2.0 | 1.0 |

|       |      |      |      |      |     |     |     |
|-------|------|------|------|------|-----|-----|-----|
| 387.0 | 82.0 | 30.0 | 16.0 | 8.0  | 5.0 | 1.0 | .0  |
| 394.0 | 78.0 | 24.0 | 13.0 | 8.0  | 3.0 | 1.0 | 1.0 |
| 429.0 | 78.0 | 33.0 | 16.0 | 9.0  | 2.0 | 2.0 | 1.0 |
| 415.0 | 70.0 | 26.0 | 8.0  | 9.0  | 1.0 | 2.0 | 2.0 |
| 396.0 | 72.0 | 33.0 | 12.0 | 7.0  | 3.0 | .0  | 1.0 |
| 420.0 | 71.0 | 22.0 | 13.0 | 6.0  | .0  | 1.0 | .0  |
| 420.0 | 71.0 | 31.0 | 10.0 | 6.0  | 2.0 | .0  | 1.0 |
| 408.0 | 75.0 | 32.0 | 9.0  | 10.0 | 4.0 | .0  | .0  |
| 356.0 | 75.0 | 36.0 | 22.0 | 12.0 | 2.0 | 2.0 | 1.0 |
| 412.0 | 71.0 | 25.0 | 12.0 | 6.0  | 2.0 | 2.0 | 3.0 |
| 374.0 | 77.0 | 21.0 | 15.0 | 4.0  | 3.0 | 2.0 | .0  |
| 372.0 | 60.0 | 25.0 | 20.0 | 6.0  | 3.0 | 2.0 | 2.0 |
| 376.0 | 84.0 | 27.0 | 11.0 | 8.0  | 5.0 | 2.0 | .0  |
| 435.0 | 76.0 | 22.0 | 10.0 | 4.0  | 5.0 | 2.0 | 1.0 |
| 420.0 | 66.0 | 32.0 | 14.0 | 7.0  | 1.0 | 5.0 | 1.0 |
| 353.0 | 90.0 | 28.0 | 13.0 | 8.0  | 1.0 | .0  | .0  |
| 376.0 | 89.0 | 25.0 | 13.0 | 3.0  | 2.0 | 6.0 | .0  |

0 LOCATION: 79 NOZZLE PRESSURE: 2.5  
 F SETTING: 1.5 HOOD OPENING: 3.0  
 SAMPLE TIME: 300.

|       |      |      |      |     |     |     |     |
|-------|------|------|------|-----|-----|-----|-----|
| 165.0 | 31.0 | 5.0  | 10.0 | 3.0 | .0  | .0  | .0  |
| 200.0 | 46.0 | 6.0  | 7.0  | 1.0 | 1.0 | .0  | .0  |
| 212.0 | 36.0 | 11.0 | 4.0  | 2.0 | 1.0 | .0  | .0  |
| 184.0 | 45.0 | 9.0  | 7.0  | 1.0 | .0  | .0  | .0  |
| 217.0 | 40.0 | 12.0 | 5.0  | 2.0 | 2.0 | 1.0 | 1.0 |
| 172.0 | 26.0 | 12.0 | 6.0  | 3.0 | 1.0 | .0  | .0  |
| 194.0 | 36.0 | 9.0  | 2.0  | 5.0 | 1.0 | .0  | .0  |
| 199.0 | 43.0 | 10.0 | 5.0  | 3.0 | 3.0 | .0  | .0  |
| 187.0 | 38.0 | 5.0  | 4.0  | 4.0 | 1.0 | .0  | 1.0 |
| 194.0 | 30.0 | 11.0 | 3.0  | 2.0 | 3.0 | .0  | .0  |
| 193.0 | 36.0 | 10.0 | 2.0  | 3.0 | 2.0 | .0  | .0  |
| 193.0 | 31.0 | 10.0 | 6.0  | 4.0 | 1.0 | .0  | 1.0 |
| 178.0 | 50.0 | 11.0 | 6.0  | .0  | .0  | .0  | .0  |
| 183.0 | 32.0 | 11.0 | 7.0  | .0  | .0  | .0  | .0  |
| 207.0 | 43.0 | 9.0  | 8.0  | 1.0 | 1.0 | .0  | .0  |
| 174.0 | 38.0 | 5.0  | 6.0  | 1.0 | 2.0 | .0  | .0  |
| 200.0 | 49.0 | 15.0 | 5.0  | 2.0 | 1.0 | 1.0 | .0  |
| 172.0 | 42.0 | 9.0  | 4.0  | 1.0 | 1.0 | .0  | .0  |
| 192.0 | 53.0 | 13.0 | .0   | 1.0 | 2.0 | .0  | .0  |
| 215.0 | 41.0 | 17.0 | 4.0  | 2.0 | 2.0 | .0  | .0  |
| 179.0 | 46.0 | 15.0 | .0   | 2.0 | 2.0 | 1.0 | .0  |
| 201.0 | 34.0 | 15.0 | 2.0  | 1.0 | 1.0 | .0  | .0  |
| 202.0 | 41.0 | 6.0  | 5.0  | 2.0 | 1.0 | .0  | .0  |
| 189.0 | 33.0 | 10.0 | 4.0  | .0  | .0  | .0  | .0  |
| 208.0 | 33.0 | 16.0 | 3.0  | .0  | 2.0 | .0  | .0  |

0 LOCATION: 54 NOZZLE PRESSURE: 2.5  
 F SETTING: 1.5 HOOD OPENING: 3.0  
 SAMPLE TIME: 300.

|       |      |      |      |     |     |     |     |
|-------|------|------|------|-----|-----|-----|-----|
| 222.0 | 41.0 | 12.0 | 3.0  | 7.0 | 1.0 | .0  | .0  |
| 202.0 | 40.0 | 17.0 | 5.0  | 3.0 | .0  | 1.0 | .0  |
| 211.0 | 38.0 | 18.0 | 5.0  | 1.0 | .0  | 2.0 | .0  |
| 231.0 | 33.0 | 14.0 | 6.0  | .0  | 2.0 | 1.0 | 1.0 |
| 248.0 | 44.0 | 22.0 | 17.0 | 4.0 | 1.0 | .0  | .0  |

|       |      |      |      |     |     |     |     |
|-------|------|------|------|-----|-----|-----|-----|
| 253.0 | 39.0 | 12.0 | 7.0  | 1.0 | 1.0 | 1.0 | 3.0 |
| 224.0 | 55.0 | 18.0 | 7.0  | 2.0 | 1.0 | .0  | .0  |
| 213.0 | 47.0 | 11.0 | 12.0 | 2.0 | 1.0 | .0  | .0  |
| 229.0 | 46.0 | 13.0 | 5.0  | 3.0 | 2.0 | 1.0 | .0  |
| 252.0 | 43.0 | 10.0 | 7.0  | 4.0 | 1.0 | 1.0 | .0  |
| 241.0 | 47.0 | 8.0  | 2.0  | 3.0 | 1.0 | .0  | .0  |
| 245.0 | 41.0 | 17.0 | 7.0  | 1.0 | .0  | .0  | .0  |
| 185.0 | 35.0 | 10.0 | 9.0  | 2.0 | 1.0 | 1.0 | 1.0 |
| 241.0 | 46.0 | 12.0 | 6.0  | .0  | 1.0 | 2.0 | .0  |
| 241.0 | 33.0 | 12.0 | 8.0  | 4.0 | .0  | 2.0 | .0  |
| 233.0 | 51.0 | 19.0 | 2.0  | 3.0 | 2.0 | 1.0 | .0  |
| 231.0 | 33.0 | 8.0  | 4.0  | 2.0 | .0  | 1.0 | .0  |
| 241.0 | 53.0 | 17.0 | 6.0  | 2.0 | 2.0 | .0  | 1.0 |
| 208.0 | 42.0 | 13.0 | 6.0  | 3.0 | 3.0 | .0  | .0  |
| 235.0 | 32.0 | 20.0 | 6.0  | 3.0 | 4.0 | 1.0 | .0  |
| 216.0 | 46.0 | 10.0 | 9.0  | 3.0 | .0  | 1.0 | 1.0 |
| 211.0 | 44.0 | 15.0 | 3.0  | 2.0 | 1.0 | 1.0 | .0  |
| 259.0 | 58.0 | 17.0 | 8.0  | 5.0 | .0  | .0  | .0  |
| 222.0 | 52.0 | 18.0 | 6.0  | 2.0 | 3.0 | .0  | 1.0 |
| 222.0 | 44.0 | 21.0 | 3.0  | 3.0 | .0  | .0  | 1.0 |
| 223.0 | 38.0 | 12.0 | 8.0  | 1.0 | 4.0 | .0  | .0  |

0 LOCATION: 18 NOZZLE PRESSURE: 2.5  
 F SETTING: 1.5 HOOD OPENING: 3.0  
 SAMPLE TIME: 300.

|       |      |      |      |     |     |     |     |
|-------|------|------|------|-----|-----|-----|-----|
| 222.0 | 41.0 | 8.0  | 1.0  | 2.0 | .0  | .0  | .0  |
| 269.0 | 42.0 | 8.0  | 6.0  | 1.0 | 1.0 | 1.0 | .0  |
| 255.0 | 42.0 | 13.0 | 9.0  | 1.0 | 3.0 | .0  | .0  |
| 255.0 | 42.0 | 12.0 | 10.0 | 2.0 | 2.0 | 1.0 | .0  |
| 255.0 | 37.0 | 14.0 | 5.0  | 3.0 | .0  | 1.0 | .0  |
| 217.0 | 31.0 | 15.0 | 4.0  | 1.0 | 2.0 | .0  | 2.0 |
| 254.0 | 45.0 | 20.0 | 5.0  | 5.0 | .0  | .0  | .0  |
| 243.0 | 40.0 | 16.0 | 3.0  | 2.0 | .0  | .0  | .0  |
| 241.0 | 42.0 | 22.0 | 6.0  | 2.0 | 2.0 | .0  | .0  |
| 209.0 | 34.0 | 7.0  | 6.0  | 4.0 | 2.0 | .0  | .0  |
| 267.0 | 41.0 | 15.0 | 6.0  | 2.0 | 3.0 | .0  | .0  |
| 239.0 | 30.0 | 6.0  | 7.0  | 1.0 | 1.0 | 2.0 | .0  |
| 251.0 | 43.0 | 10.0 | 10.0 | 1.0 | .0  | 1.0 | 1.0 |
| 251.0 | 51.0 | 16.0 | 4.0  | 1.0 | 1.0 | 1.0 | .0  |
| 300.0 | 59.0 | 19.0 | 10.0 | 4.0 | 3.0 | .0  | .0  |
| 222.0 | 19.0 | 9.0  | 3.0  | 3.0 | .0  | .0  | 1.0 |
| 242.0 | 43.0 | 14.0 | 5.0  | 3.0 | 2.0 | 1.0 | .0  |
| 241.0 | 42.0 | 10.0 | 4.0  | 1.0 | 1.0 | .0  | .0  |
| 201.0 | 32.0 | 8.0  | 5.0  | 1.0 | 1.0 | .0  | .0  |
| 233.0 | 31.0 | 12.0 | 7.0  | 2.0 | 1.0 | .0  | 1.0 |
| 242.0 | 38.0 | 12.0 | 1.0  | 1.0 | 4.0 | 1.0 | .0  |
| 220.0 | 37.0 | 7.0  | 4.0  | 4.0 | 2.0 | .0  | .0  |
| 216.0 | 35.0 | 16.0 | 4.0  | 1.0 | .0  | .0  | .0  |
| 247.0 | 53.0 | 19.0 | 11.0 | 6.0 | 1.0 | .0  | 1.0 |
| 195.0 | 26.0 | 7.0  | 6.0  | 2.0 | 2.0 | .0  | .0  |

0 LOCATION: 45 NOZZLE PRESSURE: 2.5  
 F SETTING: 1.5 HOOD OPENING: 3.0  
 SAMPLE TIME: 300.

|       |      |     |     |     |    |    |    |
|-------|------|-----|-----|-----|----|----|----|
| 168.0 | 22.0 | 7.0 | 5.0 | 1.0 | .0 | .0 | .0 |
|-------|------|-----|-----|-----|----|----|----|

|       |      |      |     |     |     |     |     |
|-------|------|------|-----|-----|-----|-----|-----|
| 158.0 | 28.0 | 12.0 | 4.0 | 1.0 | 1.0 | .0  | .0  |
| 145.0 | 19.0 | 9.0  | 3.0 | .0  | .0  | 1.0 | .0  |
| 173.0 | 20.0 | 4.0  | 1.0 | .0  | .0  | .0  | .0  |
| 168.0 | 27.0 | 13.0 | 5.0 | .0  | .0  | .0  | .0  |
| 159.0 | 35.0 | 11.0 | 4.0 | 1.0 | .0  | .0  | .0  |
| 192.0 | 35.0 | 10.0 | 2.0 | 2.0 | 1.0 | 1.0 | .0  |
| 192.0 | 16.0 | 12.0 | 2.0 | 2.0 | .0  | .0  | .0  |
| 186.0 | 23.0 | 10.0 | 3.0 | .0  | .0  | .0  | .0  |
| 175.0 | 22.0 | 8.0  | 3.0 | 2.0 | .0  | .0  | .0  |
| 167.0 | 25.0 | 8.0  | 4.0 | .0  | .0  | 1.0 | .0  |
| 136.0 | 28.0 | 6.0  | 4.0 | 1.0 | 1.0 | .0  | .0  |
| 144.0 | 26.0 | 9.0  | 5.0 | 1.0 | 1.0 | .0  | .0  |
| 175.0 | 24.0 | 11.0 | 5.0 | 1.0 | .0  | .0  | .0  |
| 178.0 | 26.0 | 13.0 | 6.0 | .0  | .0  | .0  | .0  |
| 167.0 | 21.0 | 10.0 | 1.0 | 2.0 | .0  | .0  | .0  |
| 166.0 | 33.0 | 9.0  | 1.0 | 2.0 | .0  | 1.0 | 1.0 |
| 181.0 | 25.0 | 8.0  | 6.0 | 2.0 | 1.0 | .0  | .0  |
| 166.0 | 23.0 | 8.0  | 1.0 | 3.0 | 1.0 | .0  | .0  |
| 165.0 | 27.0 | 7.0  | 3.0 | 1.0 | .0  | .0  | .0  |
| 174.0 | 18.0 | 6.0  | 6.0 | .0  | 1.0 | 1.0 | .0  |
| 181.0 | 28.0 | 12.0 | 4.0 | 2.0 | .0  | 1.0 | .0  |
| 167.0 | 28.0 | 12.0 | 3.0 | 3.0 | .0  | .0  | .0  |
| 164.0 | 23.0 | 7.0  | 3.0 | 2.0 | .0  | .0  | .0  |
| 149.0 | 21.0 | 6.0  | 1.0 | 1.0 | .0  | .0  | .0  |

LOCATION 2 NOZZLE PRESSURE: 2.5  
 F SEATING: 1.5 HOOD OPENING: 3.0  
 SAMPLE TIME: 300.

|       |      |      |     |     |     |     |     |
|-------|------|------|-----|-----|-----|-----|-----|
| 308.0 | 47.0 | 9.0  | 1.0 | 2.0 | 3.0 | .0  | .0  |
| 287.0 | 55.0 | 17.0 | 3.0 | 2.0 | .0  | .0  | .0  |
| 281.0 | 37.0 | 6.0  | 3.0 | .0  | 2.0 | .0  | .0  |
| 297.0 | 41.0 | 13.0 | 5.0 | 1.0 | 1.0 | .0  | .0  |
| 281.0 | 47.0 | 14.0 | 6.0 | 1.0 | .0  | .0  | .0  |
| 273.0 | 43.0 | 7.0  | 1.0 | 1.0 | 1.0 | .0  | 1.0 |
| 273.0 | 41.0 | 5.0  | 4.0 | 1.0 | .0  | 1.0 | .0  |
| 281.0 | 36.0 | 17.0 | 2.0 | 1.0 | .0  | .0  | .0  |
| 260.0 | 45.0 | 11.0 | 2.0 | 2.0 | .0  | .0  | .0  |
| 274.0 | 38.0 | 16.0 | 6.0 | 1.0 | .0  | .0  | .0  |
| 276.0 | 48.0 | 11.0 | 2.0 | 4.0 | .0  | .0  | .0  |
| 278.0 | 42.0 | 7.0  | 2.0 | .0  | 1.0 | .0  | .0  |
| 282.0 | 49.0 | 12.0 | 6.0 | 4.0 | .0  | .0  | .0  |
| 246.0 | 43.0 | 13.0 | 8.0 | 2.0 | .0  | .0  | .0  |
| 279.0 | 36.0 | 15.0 | 6.0 | 1.0 | 2.0 | .0  | .0  |
| 300.0 | 43.0 | 8.0  | 5.0 | 3.0 | 1.0 | 2.0 | 1.0 |
| 269.0 | 34.0 | 7.0  | 2.0 | 3.0 | 2.0 | .0  | .0  |
| 297.0 | 40.0 | 12.0 | 1.0 | 1.0 | .0  | .0  | .0  |
| 262.0 | 41.0 | 11.0 | 9.0 | 3.0 | .0  | 3.0 | .0  |
| 296.0 | 41.0 | 14.0 | 1.0 | 4.0 | .0  | 1.0 | 1.0 |
| 319.0 | 37.0 | 11.0 | 4.0 | 1.0 | 2.0 | .0  | 1.0 |
| 292.0 | 39.0 | 6.0  | 4.0 | .0  | 1.0 | 2.0 | .0  |
| 283.0 | 41.0 | 14.0 | 5.0 | 1.0 | .0  | 2.0 | .0  |
| 300.0 | 36.0 | 12.0 | 4.0 | .0  | 2.0 | .0  | 1.0 |
| 283.0 | 36.0 | 8.0  | 3.0 | 1.0 | 2.0 | 2.0 | .0  |
| 265.0 | 43.0 | 9.0  | 8.0 | 2.0 | 1.0 | .0  | .0  |

DISTRIBUTION LIST

| <u>ORGANIZATION</u>  | <u>NUMBER OF COPIES</u> |
|--|-------------------------|
| Defense Technical Information Center<br>Cameron Station<br>Alexandria VA 22314 | 12                      |
| Air University (LSE)<br>Maxwell AFB AL 36112                                   | 1                       |
| HQ AD (TE)<br>Eglin AFB FL 32542   | 1                       |
| 6585th Test Group<br>Holloman AFB NM 88330                                     |                         |
| (WE)   | 10                      |
| (TKI)  | 1                       |
| (TSL)  | 1                       |
| (TKA)  | 1                       |
| 30 Weather SQ (MAC)<br>Attn: Maj Shipe<br>Yong San Ain Korea APO SF 96301      | 3                       |
| AFSC/WER<br>Bldg 1522A<br>Andrews AFB DC 20334                                 | 1                       |
| USAFETAC/TS<br>Scott AFB IL 62225  | 1                       |

END

DATE  
FILMED

12-83

DTIC