

AD A 134615

22 September 1969

Materiel Test Procedure 6-2-050
Electronic Proving Ground

U. S. ARMY TEST AND EVALUATION COMMAND
COMMODITY ENGINEERING TEST PROCEDURE

SIGNAL CONVERTERS

3489

1. OBJECTIVE

The objective of the procedures outlined in this MTP is to provide a means of evaluating the technical performance and technical characteristics of signal converters relative to criteria specified in Qualitative Materiel Requirements (QMR), Small Development Requirements (SDR), Technical Characteristics (TC), or other applicable documents, and determining their suitability for an intended use.

2. BACKGROUND

The many types and possible combinations of communication facilities, systems, and associated signaling schemes comprising a military network requires the use of signal converters in different forms at strategic points in order to effect overall signaling compatibility.

The class of signal converters covered by this MTP are those items whose principal purpose is to alter the form of telephone or telegraph functional signals in circuits having dissimilar line or terminal signaling characteristics. Functional signals are defined as those employed in most communication circuits to operate signaling devices or switching equipment as opposed to the intelligence-bearing signals (speech, data, and images).

The majority of communication circuits employ two-way signaling, therefore signal converters which may be required must be capable of performing the basic signaling functions in both directions regardless of the circuit configuration such as 2-wire, 4-wire, or combinations of the two in tandem. See Figure 1 and 2 for a basic representative circuit. The basic functions and characteristics of a signal converter are as follows:

- a. Accept signaling information in one electrical form from one direction and relay it in a different electrical form such as DC to AC, and low-frequency AC to a high-frequency AC.
- b. Accurately repeat the signaling condition and sequence such as "on hook/off hook", telephone dial pulses to "touch tone" frequencies.
- c. Provide an essentially loss-less and distortion-less voice path through the converter when in the "talking" condition.

3. REQUIRED EQUIPMENT

- a. Signal/function generators
- b. Oscillators
- c. Frequency meter/electronic counter
- d. Wave analyzer
- e. Distortion analyzer
- f. Noise measuring set
- g. Transmission measuring set

Best Available Copy

2004 0205 034

4-wire Line
(vf signals/speech)

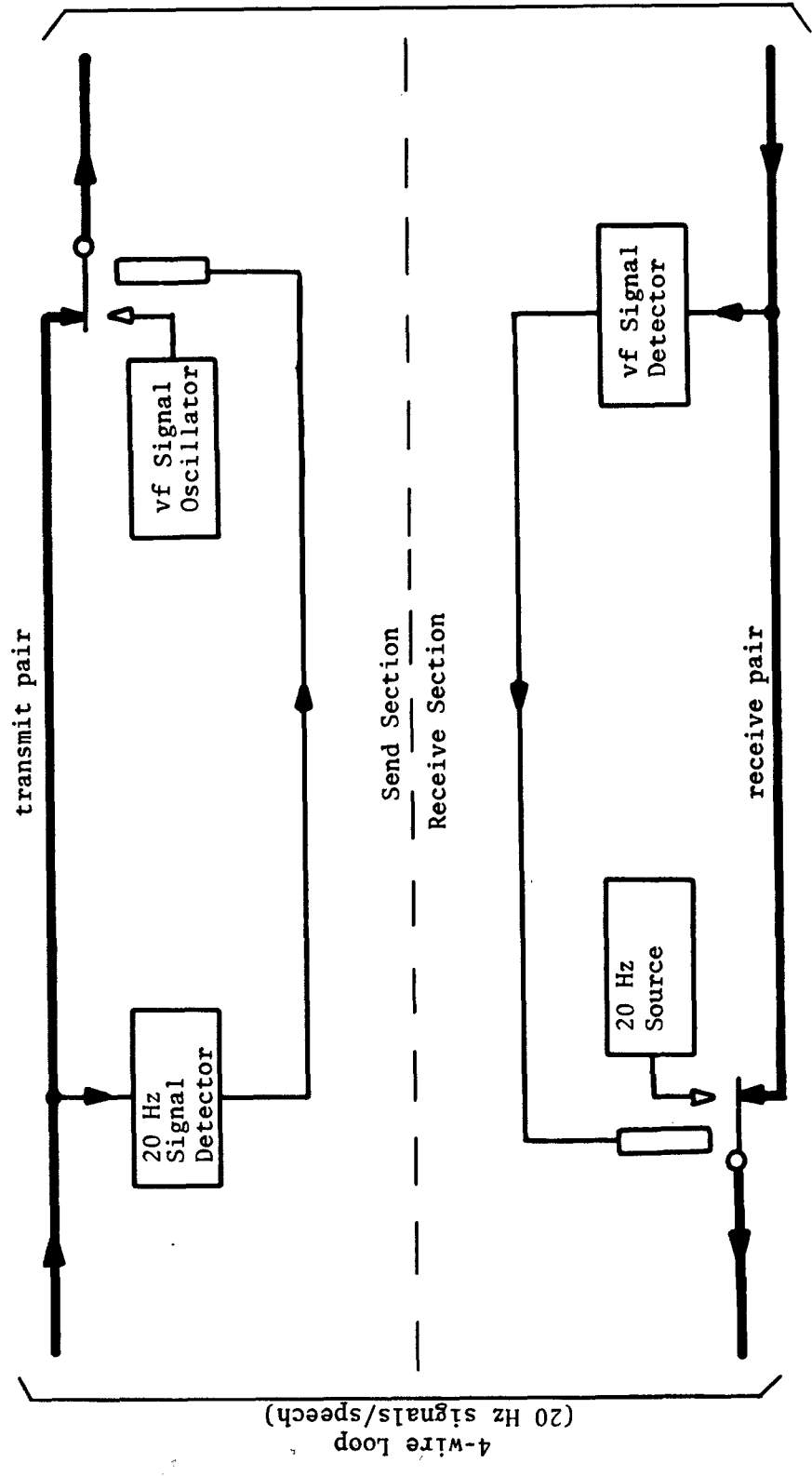
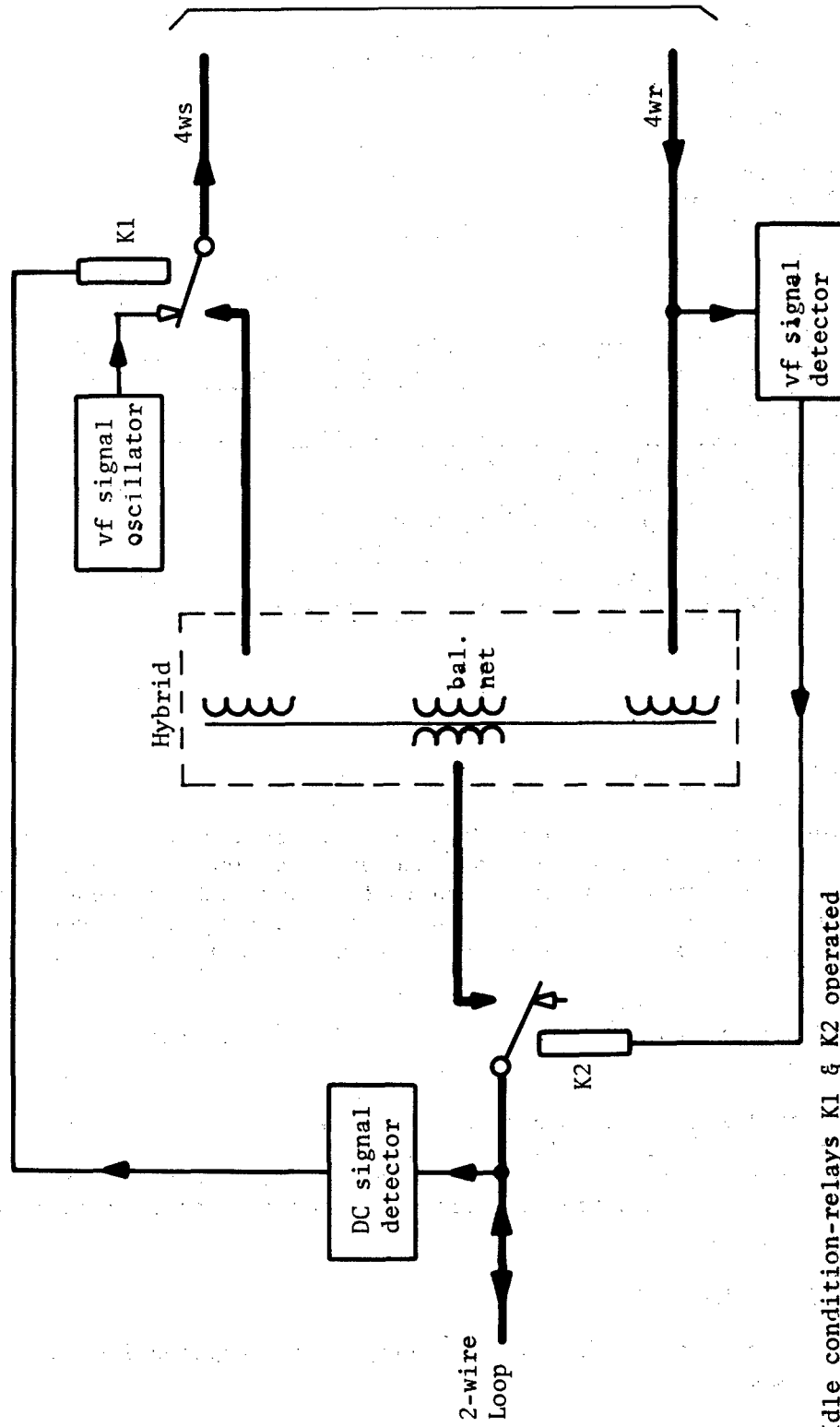

Figure 1. Simplified Block Diagram of a Signal Converter Arranged for Ringdown Signaling
4-wire Configuration.



4-wire Line

Idle condition-relays K1 & K2 operated
 Loop-to-line signaling-relay K1 released
 Line-to-loop signaling-relay K2 released
 Talk condition-K1 & K2 released

Figure 2. Simplified Block Diagram of a Signal Converter Arranged for Plug Supervision Signaling or

Equivalent - 2-wire/4-wire Configuration.

- h. Delay distortion test set
- i. Dial pulse speed/ratio test set or equivalent
- j. Voltmeter, AC, low frequency
- k. Voltmeter, AC, (db)
- l. Multimeters
- m. Oscilloscope w/camera
- n. Decade resistance box
- o. Electronic laboratory or equivalent

4. REFERENCES

- A. MIL-STD-188, Military Communication System Technical Standards.
- B. MIL-STD-462, Electromagnetic Interference Characteristics Measurement of.
- C. TM 11-486, Electrical Communication Systems Engineering.
- D. TM 11-678, Fundamentals of Telephony.
- E. MTP 6-2-200, PCM Multiplexers.
- F. MTP 6-2-230, Radio Control Equipment.
- G. MTP 6-2-242, Receiver-Transmitter, General.
- H. MTP 6-2-265, Switchboards
- I. MTP 6-2-290, Terminals, Telephone and Telegraph.

5. SCOPE

5.1 SUMMARY

5.1.1 Technical Characteristics

The procedures outlined in this MTP provide general guidance for determining and evaluating the technical performance and technical characteristics of signal converters. The cumulative test results together with the results of the appropriate Common Engineering Tests will allow an estimate of the test items capabilities and the suitability of the equipment to meet the required military needs.

The specific tests to be performed, along with their intended objectives, are listed below:

- a. Signaling Tests - The objective of this subtest is to determine the technical characteristics of the signal converter.
- b. Transmission Tests - The objective of this subtest is to determine the technical performance of the signal converter in operation as a functional system.

5.1.2 Common Engineering Tests

Not included in this MTP are the following Common Engineering Tests which apply to this commodity.

- a. 6-2-500, Physical Characteristics
- b. 6-2-502, Human Factors Engineering

- c. 6-2-503, Reliability
- d. 6-2-504, Design for Maintainability
- e. 6-2-507, Safety

5.2 LIMITATIONS

The procedures outlined in this MTP excludes the testing of items designed for conversion of information-type signals such as data modems, vo-coders, facsimile converters telegraph signal converters or integral signaling components which employs out-of-band signaling.

The testing methods outlined may be adapted as necessary to accom-modate signaling functions of communication terminal equipment wherein signal-ing conversion features are incidental to the principal function.

6. PROCEDURES

6.1 PREPARATION FOR TEST

a. Select test equipment ideally having an accuracy of ten orders of magnitude greater than that of the item under test, and that is in keeping with the state of the art, and with calibrations traceable to the National Bureau of Standards.

b. Record the following information:

- 1) Nomenclature, serial number(s), manufacturer's name, and function of the item(s) test.
- 2) Nomenclature, serial number, accuracy tolerances, calibration requirements, and last date calibrated of the test equipment selected for the tests.

c. Ensure that all test personnel are familiar with the required technical and operational characteristics of the test items under test, such as stipulated in QMR's, SDR's, and TC's.

d. Prepare adequate safety precautions to provide safety for per-sonnel and equipment, and ensure that all safety SOP's are observed throughout the test.

e. Prepare record forms for systematic entry of data, chronology of test, and analysis in final evaluation of the test item.

f. Prepare a test item sample plan sufficient to ensure that enough samples of all measurements are taken to provide statistical confidence of final data in accordance with MTP 3-1-002. Provisions shall be made for modification during test progress as indicated by monitored test results.

g. Ensure that all test personnel have reviewed all instructional material issued with the test item by the manufacturer, contractor, or govern-ment, and performed such preliminary tests as necessary to assure that the test item is in satisfactory condition.

NOTE: Whatever the actual calibration or test procedure to be followed, preliminary preparation of the test item should always include:

- 1) Visual inspection for obvious physical defects.
- 2) Preliminary maintenance pointed out by the previous steps.
- 3) Zero setting of all indicators.
- 4) Determination of "intended use" position of the various instruments.
- 5) Sufficient warm-up time for all electronic devices.

6.2 TEST CONDUCT

6.2.1 Signaling Tests

6.2.1.1 Send Section

- a. Measure the loop input sensitivity by increasing the source voltage in steps while operating the test key intermittently and observing the live output ACVM for an indication of response. See Figure 3.
- b. Record the minimum and optimum input voltages at which the output meter reliably follows the test key operations.
- c. Repeat steps (a) and (b) above for both AC and DC input operations.

NOTE: If the test item loop input is designed to operate from a "dry" external loop (DC supplied by test item), a variable resistance shall be used in lieu of the external DC source. The resistance values effecting the operate and non-operate functions shall be determined and recorded in ohms.

- d. With an optimum loop input condition producing a steady output signal, measure and record the frequency (Hz) and power (dbm) of the line output signal.

NOTE: If the test item employs a complex variable frequency line signal, measure the frequency components and photograph a calibrated oscilloscope presentation of the composite signal.

6.2.1.2 Receive Section

- a. Adjust the signal generator(s) frequency to produce a test signal as required by the test item design requirements and record the minimum measurable level. See Figure 4.
- b. Measure the line input sensitivity by increasing the test signal level in steps while operating the test key intermittently and observing the loop output meter for indication of response.
- c. Record the following information:
 - 1) Minimum and maximum line input levels (dbm) at which the loop output signal reliably follows the test key operations.
 - 2) Test signal frequency.
- d. Determine the line input signaling bandwidth by:
 - 1) Resetting the test signal to an optimum level to produce a

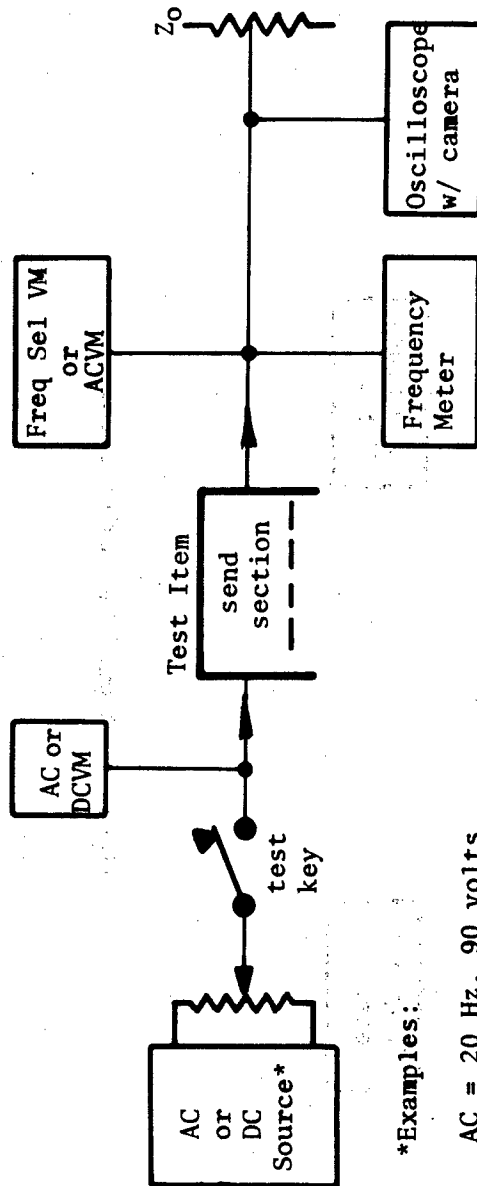

*Examples:

AC = 20 Hz, 90 volts

DC = -60 volts

Figure 3. Signal Sending Test Setup

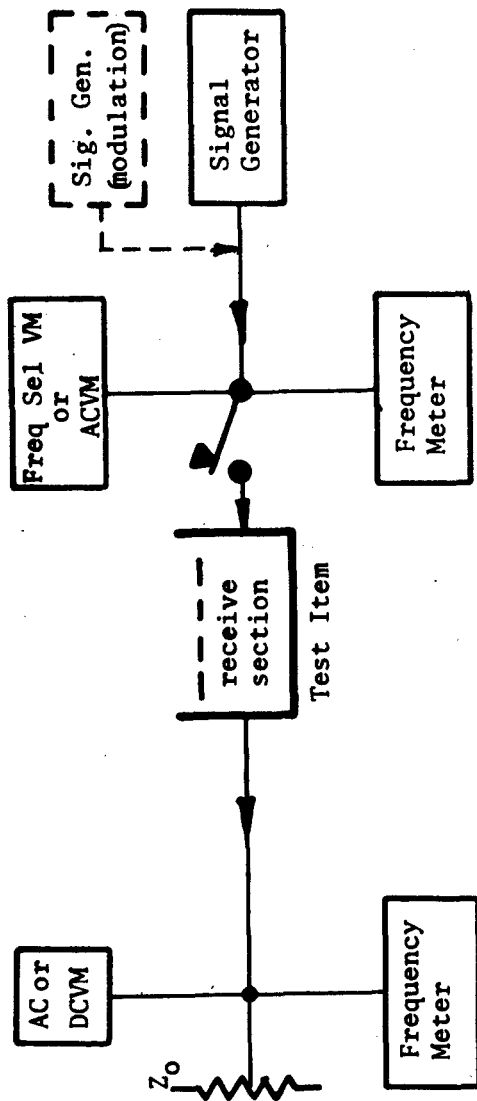

Figure 4. Signal Receiving Setup

steady loop output indication

- 2) Varying the test signal frequency above and below the test frequency of step c above.

e. Record the upper and lower frequencies at which the loop output signal disappears,

f. Determine the possibility of false operation from voice signals by extending the test signal frequency to the upper and lower limits of the voice band and noting if the loop output signal re-appears.

g. Record the following information:

- 1) The frequency range covered
- 2) If results are positive or negative
- 3) Frequency(s) and power level at which false operation occurs

6.2.1.3 Pulsed Signal Response

NOTE: This portion of the test is applicable to signal converters designed to operate in dial telephone circuits wherein the digital signals are in the form of DC pulses and therefore require conversion to voice-frequency AC pulses (AM or FSK) for transmission over voice-frequency channel facilities.

A typical test setup is shown in Figure 5 with test items employing conventional E & M signaling; the tests are also adaptable to test items which are designed for DC pulsing directly on the voice loops. Output of the "pulsed DC source" (pulse generator) shall be adjustable and compatible with the test item send input characteristics with respect to voltage, current, and pulse repetition rate. The receiving test circuitry and equipment shall be correspondingly compatible with the receive section output characteristics. The following test sequence is suggested:

- a. Adjust the pulse generator to produce a continuous pulse train having zero distortion on distortion meter A.
- b. Record the received signal distortion indicated by meter band photograph an oscilloscope presentation of the voice-frequency line signal.
- c. If the test receive section incorporates a "bias" or "distortion" control, record the control setting at which a zero distortion signal is achieved.
- d. Readjust the pulse generator to produce a signal having marking distortion and then a spacing distortion.

NOTE: The percent of distortion shall be the same for marking and spacing.

e. Adjust the receive bias control to achieve a zero distortion received signal for the two conditions of step d. above and record the control settings.

f. Interchange the test item samples and repeat the above procedures to obtain test data from all possible "send" and "receive" combinations.

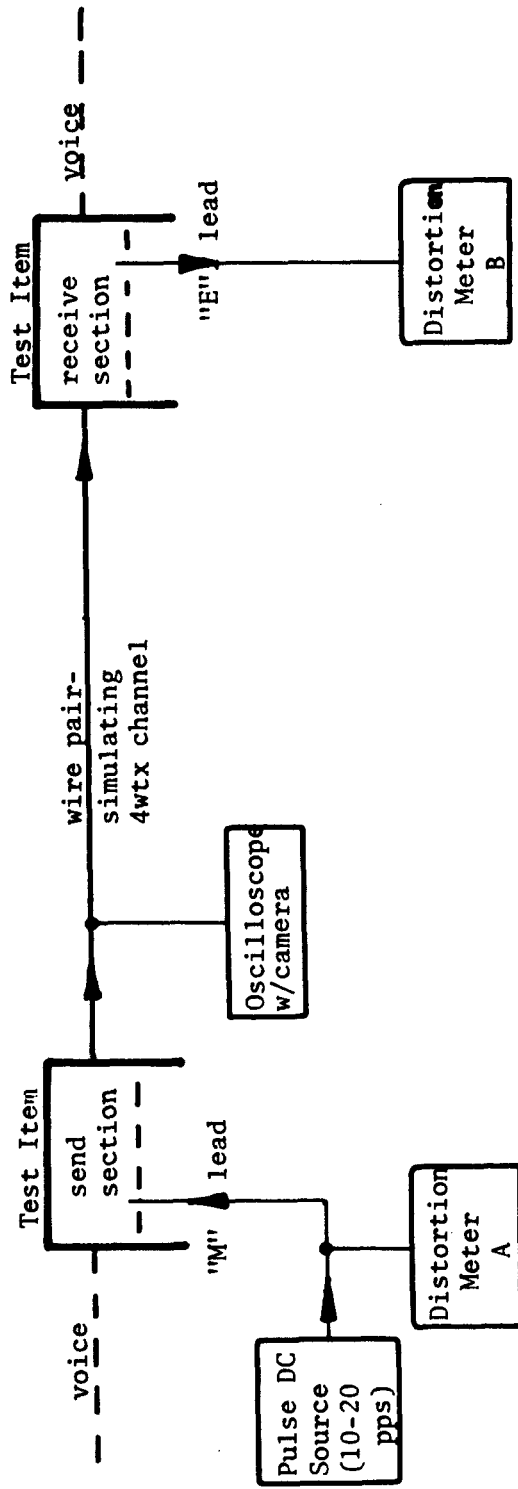

Figure 5. Test Setup for Pulsed Signal Response.

6.2.2 Transmission Tests

Conventional voice-frequency transmission tests shall be conducted with the test item in the configuration as shown in Figure 6 and in accordance with applicable sections of MTP's 6-2-200 6-2-265, and 6-2-290 and include the following:

- a. Set up the test items and maintain in the "talking" condition throughout the test.
- b. Test items employing DC loop signaling, the DC loop circuit appropriate to the "talking" condition shall be established by external means in addition to or in conjunction with the impedance termination.

- NOTE:
1. Suitable isolation shall be provided to avoid possible damage to transmission test equipment from direct current.
 2. Some signal converters perform no signal conversion function in the full 4-wire configuration, i.e., the send and receive paths are switched straight through the item and have no bridged or series circuit components other than switch contacts, the delays and harmonic distortion tests may be omitted.

c. Loop and line inputs and outputs shall be terminated in external impedances equal to loop or line characteristic impedance for which the test item is designed except when the test equipment provides the equivalent termination.

- NOTE:
1. Tests shall cover the voice-frequency band, nominally 250 Hz - 3500 Hz except as noted otherwise.
 2. It is assumed that the hybrid balancing network is the non-adjustable compromise type and that variable attenuators which may be incorporated in the 4-wire legs are set at zero loss.

d. Measure the insertion loss of each loop-line path, (4 wire and 2-wire/4-wire), at a sufficient number of frequencies to adequately describe the loss/frequency characteristic.

e. Measure the trans-hybrid loss between the 4ws line and 4 wr terminals with the 2w line side terminated as shown in Figure 7, and record the db loss.

f. Measure the longitudinal balance in both wire configurations and record the db.

g. Measure the random noise in both configurations with the specified line weighting (nominally F1A) and record in dba or dbm.

h. Multi-channel test items shall be tested for impulse noise generated in DC loops and measured on adjacent channels by an oscilloscope.

i. On single and multi-channel test items, measure the intra and inter channel crosstalk and record the db for each channel combination.

j. Measure the envelope delay distortion at selected frequencies throughout the band of interest and record in microseconds at each test frequency.

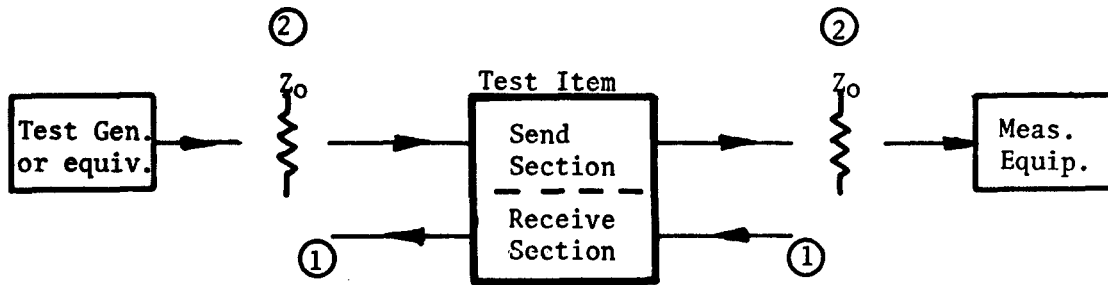

4-wire Configuration
Figure 6 Transmission Test Setup

- Notes: ① Same as send section
② As required.

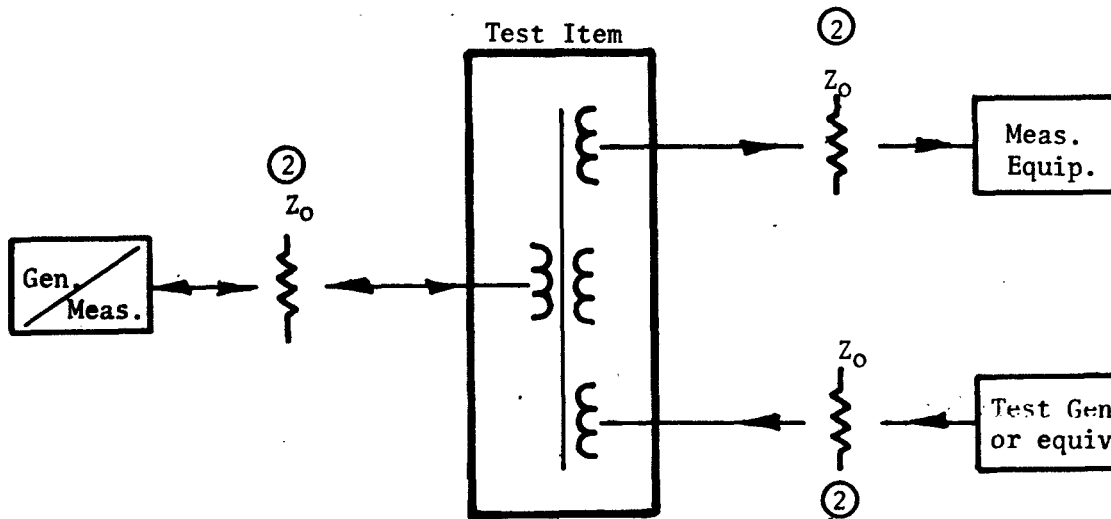

2-wire/4-wire Configuration
Figure 7 Transmission Test Setup

k. Measure the total harmonic distortion at selected frequencies throughout the band of interest and record the distortion in dbm at each test frequency.

l. Conduct electromagnetic interference tests in accordance with applicable provisions of MIL-STD-462.

NOTE: Tests of special features or options peculiar to a given test item shall be developed and conducted on basis of the specific technical characteristics involved, i.e., converters designed to interface with automatic electronic switching (AES) systems or equipment.

6.3 TEST DATA

6.3.1 Preparation for Test

Data to be recorded prior to testing shall include but not be limited to:

a. Nomenclature, serial number(s), manufacturer's name, and function of the item(s) under test.

b. Nomenclature, serial number, accuracy tolerances, calibration requirements, and last date calibrated of the test equipment selected for the tests.

6.3.2 Test Conduct

In addition to the specific data requirements delineated in subsequent paragraphs, the following items shall be preserved as a part of the test records.

a. An engineering logbook containing in chronological order, pertinent remarks and observations which will augment test data and support engineering evaluation and analysis of the technical performance of the test items.

b. Supporting photographs, calibration records, and recordings of test anomalies or deviations from the test plan made where necessary.

6.3.3 Signaling Tests

6.3.3.1 Send Section

The send section data to be recorded shall be as follows:

a. Record in tabular form the full range of loop input signal values in AC or DC volts (or ohms if applicable) and the resulting line output indication at each input step.

b. Record the line output signal frequency (Hz) and power (dbm).

c. Record the loop input signal value and characteristics.

d. Record the description of the signal characteristics and include oscilloscope photographs.

6.3.3.2 Receive Section

The receive section data to be recorded shall be as follows:

- a. Record in tabular form the full range of test signal levels (dbm) and the resulting output indication at each step.
- b. Record the line input test signal frequency characteristics.
- c. Record the line input test signal frequencies (Hz) and level (dbm) and the resulting loop output indication obtained at each frequency.
- d. Record the line input test signal frequencies (Hz) and level (dbm) and the points at which loop signal response occurs.

6.3.3.3 Pulsed Signal Response

- a. Record the loop input test signal characteristics, i.e. voltage, pulse repetition rate, and percent distortion.
- b. Record the received signal distortion (per cent marking or per cent spacing) or the distortion measured over the range of the bias control.
- c. Record the line signal of each test run and include oscilloscope photographs.

6.3.4 Transmission Tests

- a. Test data shall be recorded as indicated in paragraph 6.2.2 and MTP 6-2-200, MTP 6-2-265 and MTP 6-2-290.
- b. Electromagnetic interference test data shall be recorded as described in the applicable sections of MIL-STD-462.

6.4 DATA REDUCTION AND PRESENTATION

Processing of raw test data, in general, includes but is not limited to the following steps:

- a. Marking test data for identification and correlation.
- b. Organizing data into tabular and graphical form.
- c. Modifying data to correct for nonstandard conditions.
- d. Determining the statistical variation of the results in terms of the average value and standard deviation of the particular quantities, the correlation among two or more quantities, etc.

It is noted that the test directive (or operation) itself serves to define the types and characteristics of the raw test data, and the ultimate objective of the test program defines the form of the test data desired.

Specific instructions for the reduction and presentation of individual subtest data are outlined in subsequent paragraphs

6.4.1 Signaling Tests

- a. Sensitivity test data shall be presented in tabular form listing the range of input signal values required to produce the optimum output signal

conditions.

- b. Output signal characteristics shall be listed in tabular form, accompanied by waveform photographs as applicable.
- c. Signaling bandwidth (line input) data may be presented as a graph of frequency versus loop output response in addition to the tabulated data.
- d. False operation test results shall be described, listing the test signal frequencies and power involved.
- e. Pulsed signal response data shall be presented in tabular form describing output signal distortion versus input signal in percent marking and spacing distortion and control settings if applicable. Waveform photographs shall be included.

6.4.2 Transmission Tests

- a. Transmission test data shall be presented in graphic and tabular forms as described the applicable sections of MTP 6-2-200, MTP 6-2-265 and MTP 6-2-290.
- b. Electromagnetic interference test data shall be presented in accordance with the applicable sections of MIL-STD-462.